

KOLLMORGEN
Seidel

Digital Servodrive digifas™ 7100 series



Assembly / Installation / Commissioning

Version 01/98

Previous editions

Edition	Comments
02 / 95	First edition, valid from software version 5L10/5A10
01 / 96	Display description enlarged, software version 5L80/5A77, appendix expanded, text revised, -IL-
07 / 96	Corrections, software version 6L10/6A10
01 / 98	Corrections, -ROD/SSI- and -G- standard, Seidel Servo Drives version

**Technical changes to improve the performance of the equipment
may be made without prior notice!**

Printed in the Federal Republic of Germany 01/98

Mat. no. 83498

digifas™ is a Regd.TM.No 1549070 of Seidel Corporation

All rights reserved. No part of this work may be reproduced in any form (by printing, photocopying, microfilm or any other method) or stored, processed, copied or distributed by electronic means without the written permission of Seidel Corporation.

Contents	Diagram	Page
Contents		A
Safety instructions		C
Directives and standards		D
CE - conformance		D
I General		
I.1 About this manual		I-1
I.2 Prescribed usage of the servo amplifiers		I-1
I.3 Abbreviations used in this manual.		I-2
I.4 Nameplate	- A.4.028.6/10.	I-2
I.5 Equipment description.		I-3
I.5.1 The digifas™ 7100 series of digital servo-amplifiers		I-3
I.5.2 Digital servo-amplifier concept.		I-4
I.5.3 Operation directly off a 400V mains		I-4
I.6 Block diagram	- A.4.012.4/26.	I-5
I.7 Frontal view: digifas™ 7103...7116 operating components and connections	- A.4.012.4/14.	I-6
I.8 Frontal view: digifas™ 7133...7150 operating components and connections	- A.4.012.4/38.	I-7
I.9 Technical data of the digifas™ 7100 series		I-8
I.9.1 Permissible ambient conditions, ventilation, mounting position		I-9
I.9.2 Lead cross-sections		I-9
I.9.3 Fuse protection		I-9
I.9.4 LED display		I-9
I.10 System grounds		I-10
I.11 Ballast circuit		I-10
II Installation and commissioning		
II.1 Important instructions		II-1
II.2 Installation		II-2
II.2.1 CE - correct wiring digifas™ 7103 to 7116, general diagram.	- A.4.012.1/3.	II-4
II.2.2 Wiring diagram digifas™ 7103 to 7116 , standard unit	- A.4.012.1/2.	II-5
II.2.3 CE - correct wiring digifas™ 7133 to 7150, general diagram.	- A.4.012.1/8.	II-6
II.2.4 Wiring diagram digifas™ 7133 to 7150 , standard unit	- A.4.012.1/5.	II-7
II.2.5 Wiring example: multi-axis system	- A.4.012.1/6.	II-8
II.2.6 Pin assignments for digifas™ 7103...7116	- A.4.012.4/27.	II-9
II.2.7 Pin and terminal assignments for digifas™ 7133...7150.	- A.4.012.4/35.	II-10
II.2.8 Notes on connection methods.		II-11
II.2.8.1 Using the shield connection terminal clamps	- A.4.029.4/1.	II-11
II.2.8.2 Connecting the SubD9 connector	- A.4.029.4/2.	II-12
II.2.8.3 Using shielded leads with terminals	- A.4.029.4/3.	II-13
II.3 Commissioning.		II-14
II.4 Parameter description		II-16
II.4.1 General		II-16
II.4.2 Current controller		II-17
II.4.3 Speed controller		II-17
II.4.4 Service functions.		II-18
II.4.5 Display actual value		II-18
II.5 Fault signals, BTB signal		II-18

Contents	Diagram	Page
III Control inputs and outputs		
III.1 Input functions		III-1
III.1.1 Analog inputs		III-1
III.1.2 Digital control inputs		III-1
III.2 Output functions		III-2
III.2.1 Analog outputs		III-2
III.2.2 Digital outputs		III-2
III.2.3 Brake	- A.4.012.3/2	III-3
IV Interfaces and options		
IV.1 Incremental encoder interface (only for units without a CONNECT module)	- A.4.011.3/4	IV-1
IV.2 SSI-Interface (only for units without a CONNECT module)	- A.4.011.3/5	IV-2
IV.3 PC interface	- A.4.011.1/9	IV-3
IV.4 Key control / LC display, Option -DISP-		IV-4
IV.4.1 Key description / operation		IV-4
IV.4.2 Menu structure and operation	- A.4.012.3/1	IV-5
IV.5 Controllable torque limiting, Option -IL-		IV-6
IV.5.1 General, technical data		IV-6
IV.5.2 Important notes		IV-7
IV.5.3 Commissioning		IV-8
IV.5.4 Position of the connectors and control elements	- A.4.011.4/27	IV-8
IV.5.5 Wiring diagram, -IL- option	- A.4.011.1/15	IV-9
V Drawings		
V.1 Resolver cable for the 6SM series of motors	- A.4.017.4/10	V-1
V.2 Analog input and output circuits	- A.4.011.1/7	V-2
V.3 Digital input and output circuits	- A.4.011.1/8	V-3
V.4 Assembly levels and dimensions for digifas™ 7103...7116	- A.4.012.4/30	V-4
V.5 Installation of digifas™ 7103...7116 in a switchgear cabinet	- A.4.012.4/28	V-5
V.6 Assembly levels and dimensions for digifas™ 7133...7150	- A.4.012.4/36	V-6
V.7 Installation of digifas™ 7133...7150 in a switchgear cabinet	- A.4.012.4/37	V-7
V.8 Mains filters 1EF06 and 3EFxx series	- A.4.011.4/26	V-8
V.9 Mains choke 3L0,5-60	- A.4.012.4/29	V-9
V.10 Ballast resistor BAR860	- E.4.947.4/21	V-10
V.11 External 5V DC power supply for the position output	- A.4.012.4/31	V-11
V.12 External 24V DC power supply for a single servo-amplifier	- A.4.012.4/32	V-12
V.13 External 24V DC power supply for up to 7 servo-amplifiers	- A.4.012.4/33	V-13
VI Appendix		
VI.1 Delivery package, transport, storage, maintenance, disposal		VI-1
VI.2 ☹ - relevant system components of digifas™ 7103 to 7116	- A.4.012.1/4	VI-2
VI.3 ☹ - relevant system components of digifas™ 7133 to 7150	- A.4.012.1/9	VI-4
VI.4 Fault-finding		VI-6
VI.5 Glossary		VI-8
VI.6 Parameter list		VI-10
VI.7 Index		VI-11

Safety instructions

Warning signs : you must observe the important instructions in the text, which are indicated by the following symbols:



**hazard from electricity
and its effects**



**general warning
general instruction**

- ◆ **Only properly qualified personnel are permitted to perform activities such as transport, installation, commissioning and maintenance. Properly qualified persons are those who are familiar with transport, installation, assembly, commissioning and operation of the products, and who have the appropriate qualifications for their job. The qualified personnel must know and observe the following standards and directives:
IEC 364 and CENELEC HD 384 or DIN VDE 0100
IEC Report 664 or DIN VDE 0110
national accident prevention regulations or VBG 4**
- ◆ **Read the available documentation before carrying out installation and commissioning. Incorrect treatment of the servo amplifier can lead to injury to persons or material damage. It is vital that you keep to the technical data and information on connection requirements nameplate and documentation).**
- ◆ **The servo amplifiers contain electrostatically sensitive components which may be damaged by incorrect handling. Discharge your body before touching the servo amplifier. Avoid contact with highly insulating (artificial fabrics, plastic film etc.). Place the servo amplifier on a conductive surface.**
- ◆ **Do not open the units. Keep all covers and switchgear cabinet doors closed in operation. Otherwise there are deadly hazards with the possibility of severe danger to health or material damage.**
- ◆ **In operation, depending on the degree of enclosure protection, servo amplifiers can have bare components which are live and hot surfaces. Control and power cables can carry a high voltage even when the motor is not rotating.**
- ◆ **Never undo the electrical connections of the servo amplifier when it is live. There is a danger of electric arcing and danger to persons and contact.**
- ◆ **Wait at least two minutes after disconnecting the servo amplifier from the mains supply voltage before touching live sections of the equipment or undoing connections (e.g. contacts, screwed connections). Capacitors can have dangerous voltages present up to two minutes after switching off the supply voltages. To be sure, measure the voltage in the intermediate circuit and wait until it has fallen below 40V.**

Directives and standards

Servo amplifiers are components which are intended to be incorporated into electrical machines and plant.

When the servo amplifiers are incorporated into machines or plant, the intended operation of the amplifiers is forbidden until it has been established that the machine or plant fulfills the requirements of the EC Directive on Machines 89/392/EEC and the EC Directive on EMC 89/336/EEC. EN 60204 and EN 292 must also be observed.

In connection with the Low Voltage Directive 73/231/EEC, the harmonized standards of the EN 50178 series are applied to the servo amplifiers, together with EN 60439-1, EN 60146 and EN 60204.

The manufacturer of the machine or plant is responsible for ensuring that the machine or plant meets the limits which are laid down by the EMC regulations. Advice on the correct installation for EMC – such as shielding, grounding, arrangement of filters, treatment of connectors and laying out the cabling – is included in this documentation.

CE-conformance

Conformance with the EC Directive on EMC 89/336/EEC is mandatory for the supply of servo amplifiers within the European Community from the 1st. of January 1996.

The servoamplifiers of the digifas™ 7100 series have been tested in an authorized laboratory in a specified configuration with the system components described in Chapter VI.2 / VI.3.

Any divergence from the configuration and installation which is described in the documentation means that you will be responsible for the performance of new measurements to ensure that the regulatory requirements are met.

Only if the components as described in Chapter VI are used and the rules for installation in this documentation (Chapter II.2) are followed do we guarantee the conformance of the servo amplifiers with the following standards for industrial areas:

**EC EMC Directive 89/336/EEC
EC Low Voltage Directive 73/231/EEC)**

I General

I.1 About this manual

This manual forms part of the complete documentation for the digifas™ 7100 series of servo amplifiers. It describes the assembly, installation and commissioning of the standard units of this series, i.e. the versions of the servo-amplifier **without** a CONNECT module.

It also includes advice about transport, storage, maintenance and disposal of the equipment.

Other parts of the complete documentation of the digifas™ 7100 series:

- Installation / operation instructions for the PC-operator software:
BS7200 for digifas™ 7100 series Order no. 83107
- Installation / operation instructions for the digital connection to automation systems:
BIT CONNECT for digifas™ 7100-SPS series Order no. 83108
PROFIBUS CONNECT for digifas™ 7100-L2/DP series Order no. 83106
PULSE CONNECT for digifas™ 7100-STEP series Order no. 83109
CAN CONNECT for digifas™ 7100-CAN series Order no. 83105

All the necessary documentation for the particular version of the unit is delivered together with the servo-amplifier.

This manual makes the following demands on the technical staff:



Transport	:	only by personnel with knowledge of the handling of electrostatic-sensitive devices.
Installation	:	only by qualified personnel with training in electrical engineering
Commissioning	:	only by qualified personnel with extensive knowledge of the fields of electrical engineering and drive technology

I.2 Prescribed usage of the servo amplifiers

Use the digifas™ 7100 series of servo-amplifiers **only** on a three-phase 400V earthed industrial mains supply to drive a synchronous servo-motor from the 6SM series.

The servo amplifier may **only** be operated in a closed switch cabinet, taking into account the environmental requirements which are defined in Chapter I.9.1.

The digifas™ 7100 series of servo-amplifiers are **exclusively** intended for driving the 6SM series of brushless synchronous servo-motors under speed or torque control. The servo-amplifiers are installed as components of electrical equipment or machines and may only be operated as integral components of such equipment.



Only if the the system components as described in Chapter VI are used and the rules for installation in this documentation (Chapter II.2) are followed do we guarantee the conformance of the servo amplifiers with the following standards for industrial areas:
EC EMC Directive 89/336/EEC
EC Low Voltage Directive 73/231/EEC

I.3 Abbreviations used in this manual

The table below explains the abbreviations which are used in this manual.

Abbrev.	Meaning	Abbrev.	Meaning
AGND	analog ground	PELV	protected low voltage
BTB	system ready	PGND	ground for the interface used
CE	European Community	PSTOP	limit-switch input for rot. dir. CW
CLK	clock	PWM	pulse-width modulation
DGND	digital ground	RAM	memory component
DIN	German Standards Institute	R _{Ballast}	ballast resistor
EEPROM	electrically erasable programmable ROM	RB _{ext}	external ballast resistor
EMV	electromagnetic compatibility	RB _{int}	internal ballast resistor
EN	European standard	RES	resolver
ESD	electrostatic discharge	SPS	programmable logic controller (PLC)
IDC	analog current monitor	SRAM	static RAM
IEC	International Electrotechnical Commission	SSI	synchronous serial interface
IGBT	insulated-gate bipolar transistor	SW	setpoint value
ISO	International Standardization Organization	V _{AC}	AC voltage
INC	incremental interface	V _{DC}	DC voltage
LED	light-emitting diode	VDE	Association of German Electrical Engineers
N	zero pulse	VTA	analog speed monitor
NSTOP	limit-switch input for rot. dir. CCW	XGND	supply voltage ground

I.4 Nameplate

The nameplate depicted below is mounted on the servo-amplifier. The information shown below is printed in the individual sections.

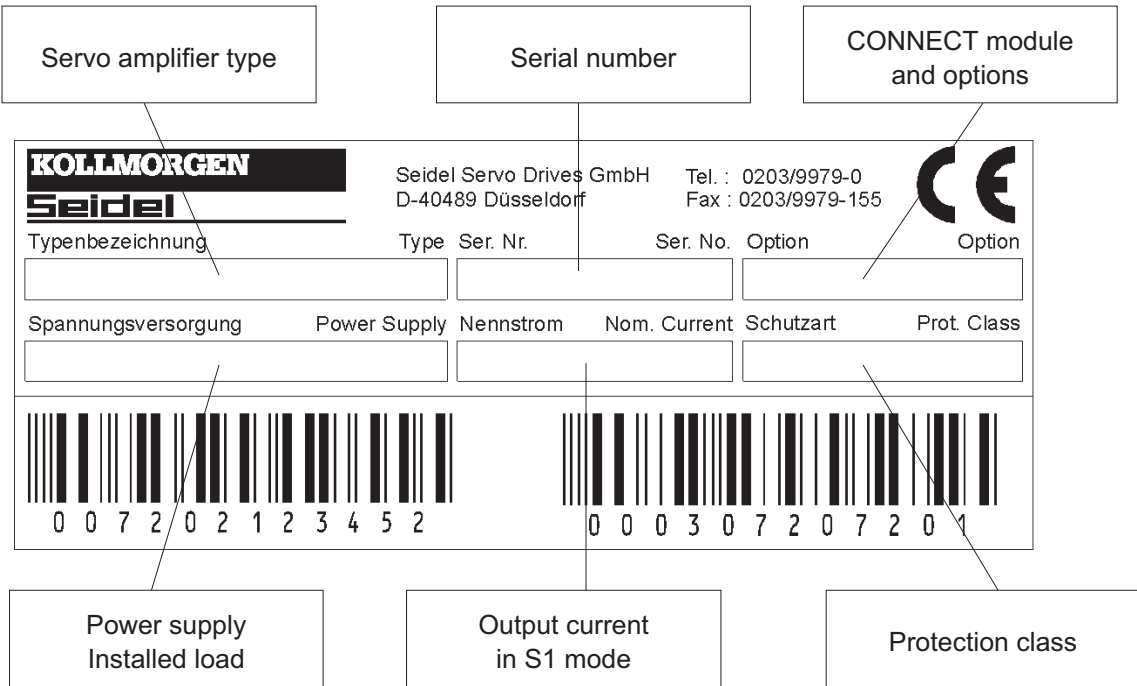

I.5.2 Digital servo-amplifier concept

Operation and parameter setting

- | | | |
|----------|---|---|
| Standard | : | Via the parallel interface of a PC using the special operator software BS7200 |
| Optional | : | By three-key operation directly on the servo-amplifier and LCD-display, only for units without a CONNECT module |

Power section

- | | | |
|-----------------|---|---|
| Mains supply | : | B6 bridge rectifier directly off the 3-phase 400V mains |
| Output stage | : | IGBT-module with electrically isolated current measurement |
| Ballast circuit | : | With electronic monitoring and internal ballast resistor.
External ballast resistor if required (please consult us about the parameter setting of the servo-amplifier) |

Digital functions

- Current and speed control
- Processing of the 14-bit resolver evaluation
- Position output (incremental or optional SSI) with analog setpoint input
- Communication with the various interface modules and positional control, if an interface module is installed

Easy-to-use functions

adjustable setpoint ramps, limit-switch function, analog monitor outputs

I.5.3 Operation directly off a 400V mains

- | | | |
|---|---|---|
| Power supply | — | Directly off an earthed 3-phase 400V mains without transformer, mains filter series 3EFxx, mains choke (digifas™ 7133/7150)
— Fuse protection and phase-failure monitoring by the user
— Single-phase supply (only for power < 0.5kW) e.g. as a possibility during commissioning or setting-up |
| Aux. supply
25V DC | — | Electrically isolated, from an external 24V DC- power supply with isolating transformer, mains filter 1EF06 |
| Intrinsic safety | — | Electrically safe isolation to EN 50178 between the mains or motor connection and the signal electronics through appropriate creepage distances and full electrical isolation.
— Soft start, overvoltage detection, short-circuit protection
— Temperature monitoring of the servo-amplifier and motor (when using motors from the 6SM series with our preassembled cables) |
| Additional interference suppression measures | — | Mains filter (see chapter V.8)
— Mains choke (see chapter V.9) |

Please consult us in the event of difficulty with an application.

I.6 Block diagram

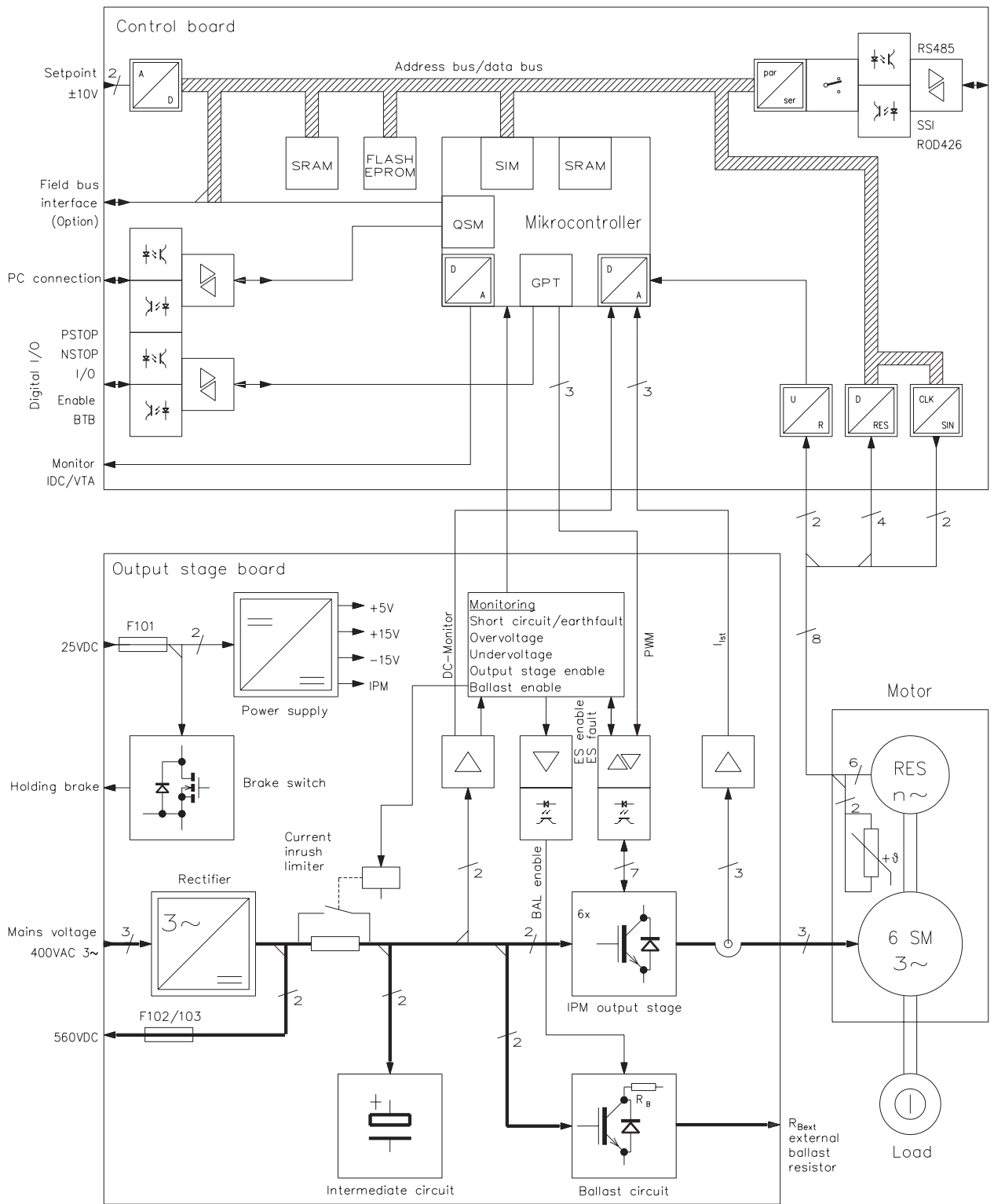

I.7 Frontal view: digifas™ 7103-7116 operating components and connections

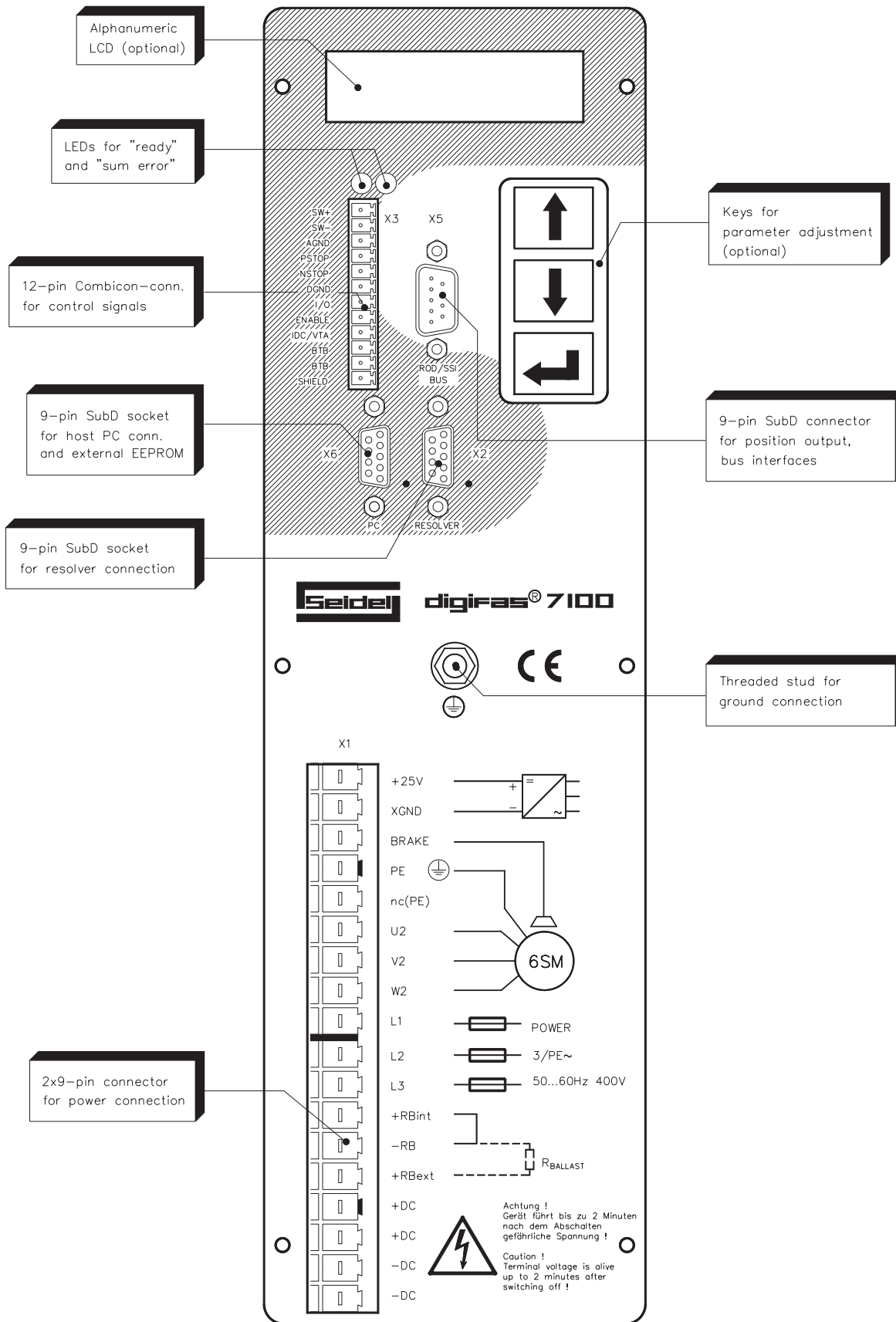

I.8 Frontal view: digifas™ 7133-7150 operating components and connections

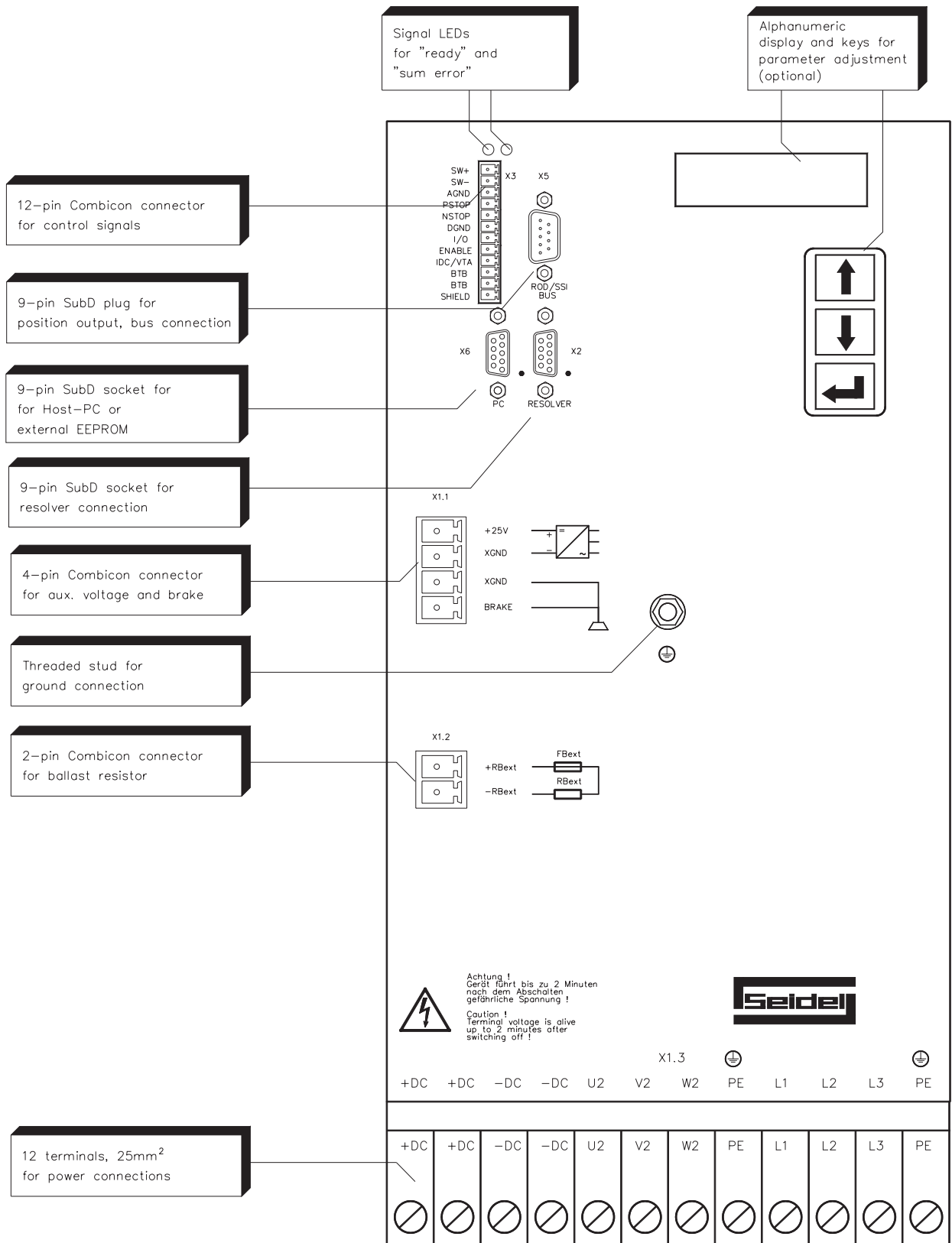

I.9 Technical data of the digifas™ 7100 series

Rated specifications	DIM	digifas™							
		7103	7105	7108	7112	7116	7133	7150	
Rated supply voltage	V~	3 x 80-400 / 50...60Hz +max. 10%							
Rated connected load for S1 operation	kVA	1.8	3	4.5	7	7 (9)*	19	30	
Rated intermediate circuit voltage	V=	560							
Rated output value (rms value, ± 3%)	A _{rms}	3	5	8	12	16	33	50	
Peak output current (max. ca. 5s, ± 3%)	A _{rms}	6	10	16	24	32	66	100	
Switch-on threshold of ballast circuit	V	720							
Switch-off threshold of ballast circuit	V	680							
Pulse power of ballast circuit (max. 1s)	kW	6.9		10.4		34.5			
(Internal) cont. power of ballast circuit (R _{Bint})	W	200							
Max. cont. power of ballast circuit (R _{Bext})	kW	2							
Min. external ballast resistor (R _{Bext})	Ω	75		50		15			
Switch-off threshold on overvoltage	V	750							
Form factor of output current (under rated specifications and min. load inductance)	—	1.01							
Min. motor inductance	mH	15	8	5	3.5	2.5	1.5	0.8	
Bandwidth of subordinate current controller	kHz	1							
Clock frequency of output stage	kHz	8.33							
Residual voltage drop at rated current	V	5							
Quiescent power loss, output stage disabled	W	15				25			
Power loss at rated current (incl. loss in power supply, without ballast dissipation)	W	50	70	100	140	180	365	540	
Inputs									
Setpoint, fixed, 14-bit resolution	V	±10							
Max. common mode voltage	V	±10							
Input resistance	kΩ	20							
Max. input drift	μV/K	±30							
Digital control inputs	V	12...36							
	mA	7							
Aux. voltage supply, isolated without brake	V	18...36							
	A	1							
Aux. voltage supply, isolated with brake	V	24 ± 10%							
	A	3				8			
max. output current brake	A	2				7			
Connections									
Control signals	Mini Combicon 3.81 / 12 pole, 1.5mm ²								
Power signals	Power Combicon 7.62 / 2 x 9-pin, 2.5mm ²						Terminals 25mm ²		
Resolver	SubD 9-pin (socket)								
PC interface	SubD 9-pin (socket)								
Position output ROD/SSI	SubD 9-pin (plug)								
digifas™ - STEP	PULSE CONNECT	Interface : Mini Combicon 3.81 / 12-pin, 1.5mm ²							
digifas™ - SPS	BIT CONNECT	Interface : Mini Combicon 3.81 / 12 pin, 1.5mm ²							
digifas™ - L2/DP	PROFIBUS CONNECT	Interface : SubD 9-pin (socket)							
digifas™ - CAN	CAN CONNECT	Interface : SubD 9-pin (socket)							
Mechanical									
Weight	kg	7.9					16,5		
Dimensions (h x w x d)	assembly level 1	mm	340x105x341				390x195x315		
	assembly level 2	mm	340x105x241				390x195x235		

* Single-axis application: 7 kVA in S1 operation, 9 kVA in S3 operation

Multi-axis application (coupled intermediate circuit) : 9 kVA in S1 operation

I.9.1 Permissible ambient conditions, ventilation, mounting position

Supply voltage tolerance Power supply Aux. voltage without brake Aux. voltage with brake Position interface supply	min. 3x80V AC / max. 3x400V AC + 10% min. 18V DC / max. 36V DC 24V DC ± 10% 5V DC ± 5%
Ambient temperature	0 ... +45°C at rated values +45 ... +55°C with power derating 2.5% / °C
Humidity	relative humidity max. 85 %, no condensation
Installation altitude	up to 1000m above mean sea level without restriction 1000...2500m above m.s.l. with power derating 1.5% / 100m
Storage temperature/humidity/time	see Chapter VI.1
Pollution level	Pollution level 2 to EN60204/EN50178
Protection class	IP 20
Mounting position	generally vertical (observe Chapter V.5 and V.7)
Ventilation digifas™ 7103/7105 digifas™ 7108...7150	electronics and heat sink: natural convection electronics: natural convection heat sink: built-in fan Make sure that there is sufficient forced circulation inside the switchgear cabinet.



I.9.2 Lead cross-sections

In accordance with EN 60204, we recommend these cross-sections for **single-axis systems**:

AC connection, intermediate circuit circuit, motor leads	digifas™ 7103/7105	: 1.5 mm ²	shielded, max. 100m on request
	digifas™ 7108/7112/7116	: 2.5 mm ²	
	digifas™ 7133	: 10 mm ²	
	digifas™ 7150	: 16 mm ²	
Resolver, motor with thermal protection	0.25 mm ² twisted pairs, shielded, max. 100m on request		
Analog setpoint, monitor signals, AGND	0.25 mm ² , twisted pairs, shielded		
Control signals, BTB, DGND	0.5 mm ²		
Holding brake (motor)	min. 0.75 mm ² , shielded, check voltage drop		
+25 V / XGND	1.5 mm ² , shielded, check voltage drop		



For multi-axis systems please observe the specific operating conditions of your system (please call us if you have any questions).

I.9.3 Fuse protection

	digifas™ 7103...7108	digifas™ 7112...7116	digifas™ 7133...7150
AC supply	external power switch for system protection, motor or transformer (C or D) characteristic, set to rated current of amplifier		
Aux. voltage 25V (F101)	internal 3.15 AT	internal 3.15 AT	internal 8 AT
Intermediate circuit (F102, F103)	internal 16 AFF	internal 16 AFF	internal 50 AFF
Ballast resistor internal	internal electronic	internal electronic	—
Ballast resistor external	external 5 AF	external 6 AF	external 2 x 16 AF

I.9.4 LED display

Green LED	equipment ready to operate / supply voltage available
Red LED	BTB-relay released, green LED is off, error signal (see Chapters II.5 and V.3), plain text message

I.10 System grounds

The following grounds are available in the system:

AGND	— reference ground for analog inputs/outputs, internal analog ground
DGND	— reference ground for digital inputs/outputs, optically isolated
XGND	— ref. ground for external 25V aux. voltage, optically and inductively isolated
PGND	— ref. ground for external supply for the position interfaces, optically isolated
GND	— ground for internal electronics (also EGND), connected to AGND

I.11 Ballast circuit

When the motor is braking, energy is fed back to the servo amplifier. This energy is converted into heat in the ballast resistor. The ballast resistor is switched in by the ballast circuit.

The maximum ballast power depends on the ballast resistor which is used and the ballast power set in the software.

If you would like some help with dimensioning the ballast power required for your system, please talk to our applications department.

Functional description:

1.- Single amplifier, not coupled via the intermediate circuit (DC+, DC-)

The circuit starts to respond from a intermediate circuit voltage of 720V.

If the power which is fed back from the motor is higher than the ballast power level which is set, then the servo amplifier signals the status "Ballast power exceeded" and the ballast circuit switches itself out.

At the next internal check of the intermediate circuit voltage (a fraction of a second later) an overvoltage will be recognized and the controller will switch off with an error message "Overvoltage" (see Chapter II.5).

2.- Several servo amplifiers coupled via the intermediate circuit circuit (DC+, DC-)

The energy which is fed back into the interm. circuit from all the motors is dealt with by all the ballast resistors which are connected. This means that the servo amplifier with the lowest ballast switch-on threshold (because of tolerances) will switch in first.

If the regenerative power is lower than the ballast power of this servo amplifier then the intermediate circuit voltage will not rise any further and no other servo amplifiers will be switched in.

If the ballast power is insufficient then the servo amplifier will signal the status "Ballast power exceeded". The intermediate circuit voltage rises further and the ballast circuit with the next higher threshold will switch in and so on.

If the total regenerative power is larger than the sum of all the ballast powers, then all the servo amplifiers will signal "Ballast power exceeded". The servo amplifier with the lowest overvoltage threshold (according to tolerance) will switch off with the error message "Overvoltage" and so switch off the complete system via the BTB contact.

Internal ballast resistor:	digifas™ 7103...7116	: 200W (as delivered)
	digifas™ 7133...7150	: not available
External ballast resistor:	digifas™ 7103...7108	: min. 75Ω, max. 2000W
	digifas™ 7112...7116	: min. 50Ω, max. 2000W
	digifas™ 7133...7150	: min. 15Ω, max. 4000W



With digifas™ 7103...7116 the link +R_{Bint} ↔ -R_B must be removed if you want to use an external ballast resistor.

II Installation and commissioning

II.1 Important instructions

Check the conformance of the servo amplifier and the motor. Compare the rated voltage and current of the equipment. Implement the wiring according to the wiring diagram in Chapter II.2.2 or II.2.4. For units with CONNECT modules, also refer to the connection diagram for the interface in the appropriate CONNECT operating manual.

Take care that, even under worst-case conditions, the maximum permissible rated voltage on the terminals L1, L2, L3 or +DC, –DC is not exceeded by more than 10% (see EN 60204-1, Sec. 4.3.1). Excessive voltage on these terminals can result in destruction of the ballast circuit and the servo amplifier. Use the digifas™ servo amplifier only on a three-phase 400V mains supply and only to drive a synchronous servomotor from the 6SM series.

Fuse protection of the AC mains supply and the 25V supply must be provided by the user. An unnoticed failure of a supply phase can result in an overload and possible destruction of the mains input rectifier. We therefore recommend the use of a power circuit-breaker with phase-failure monitoring (see Chapter I.9.3).

Make sure that mains filters, servo amplifiers and motors are properly earthed.

Run power and control cables separately. Recommended distance is more than 20 cm to improve compliance with the limits specified by the EMC regulations. If a motor power cable is used with integrated brake control leads, then the brake control leads must be shielded. The shield must be connected at both ends (see Chapter II.2.1 ff).

Install all power cables with an adequate cross-section according to EN 60204. A tabular summary of the recommended cross-sections can be found in Chapter I.9.2.

Loop the BTB contact into the safety circuit of the system. Only so can the monitoring of the servo amplifier be ensured.

Carry out all shielding with large areas (low resistance), using metallised connector housings where possible (see Chapter II.2.1 ff).

Notes on connection methods can be found in Chapter II.2.8.

Ensure an adequate supply of filtered cool air in the switchgear cabinet, fed from below. Refer to Chapter I.9.1.

Alterations in the servo-amplifier settings by means of the operator software are permitted. Any additional tampering with the equipment will invalidate the guarantee.



Caution

Never remove the electrical connections of a servo amplifier which is live.

In some cases this can cause the destruction of the electronics.

The residual charge in the capacitors can still have a dangerous level up to 120 seconds after the supply voltage has been switched off.

Measure the voltage in the intermediate circuit and wait until it has dropped below 40V.

Even when the motor is standing still, control and power terminals may still be live.

II.2 Installation

Only electrically qualified personnel are allowed to install the servo amplifier.

The installation procedure is described in examples. A different procedure may be necessary or appropriate, depending on the usage of the equipment.

More detailed knowledge can be acquired through our **training courses** (on request).



Caution!

Protect the servo amplifier from inadmissible treatment.

In particular, components must not be bent or insulation clearances changed during transport and handling.

Avoid touching electronic components and contacts.



Caution!

Only install and wire up the equipment in a de-energized condition, i.e. neither the mains supply voltage nor the 25 V auxiliary voltage nor the operating voltage of any other connected equipment may be switched on.

Make sure that the switchgear cabinet is safely disconnected (lock-out, warning signs etc.). The voltages must only be switched on for the first time during commissioning.



Note!

The ground symbol $\text{---}\text{---}\text{---}$, which will be found in all the wiring diagrams, indicates that you must provide an electrically conductive connection with as large an area as possible between the designated unit and the mounting plate in your switchgear cabinet.

This connection is for the suppression of HF interference and must not be confused with the PE-symbol \perp (which is a safety measure to EN 60204) .



Use the following wiring diagrams:

- correct EMC shielding and grounding : Chapter II.2.1 or II.2.3
- Equipment without CONNECT modules
 - Power and control connections : Chapter II.2.2 or II.2.4
- Equipment with CONNECT modules
 - Power connections : Chapter II.2.2 or II.2.4
 - Control connections : wiring diagram in the CONNECT manual
- Multi-axis system : example in Chap. II.2.5

The following instructions should help you to follow a sensible installation sequence without overlooking any important steps.

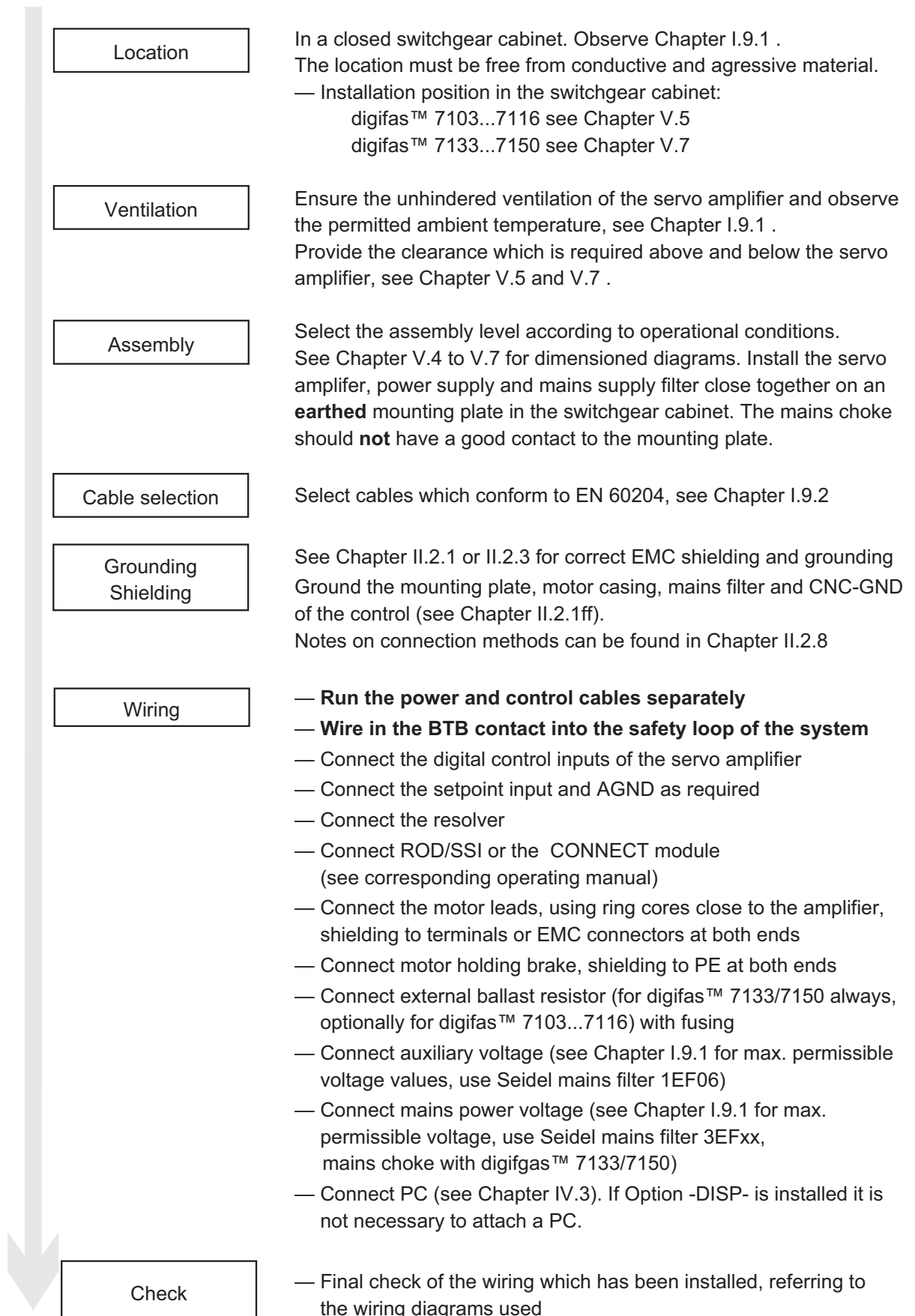

II.2.2 Wiring diagram digifas™ 7103 to 7116 , standard unit

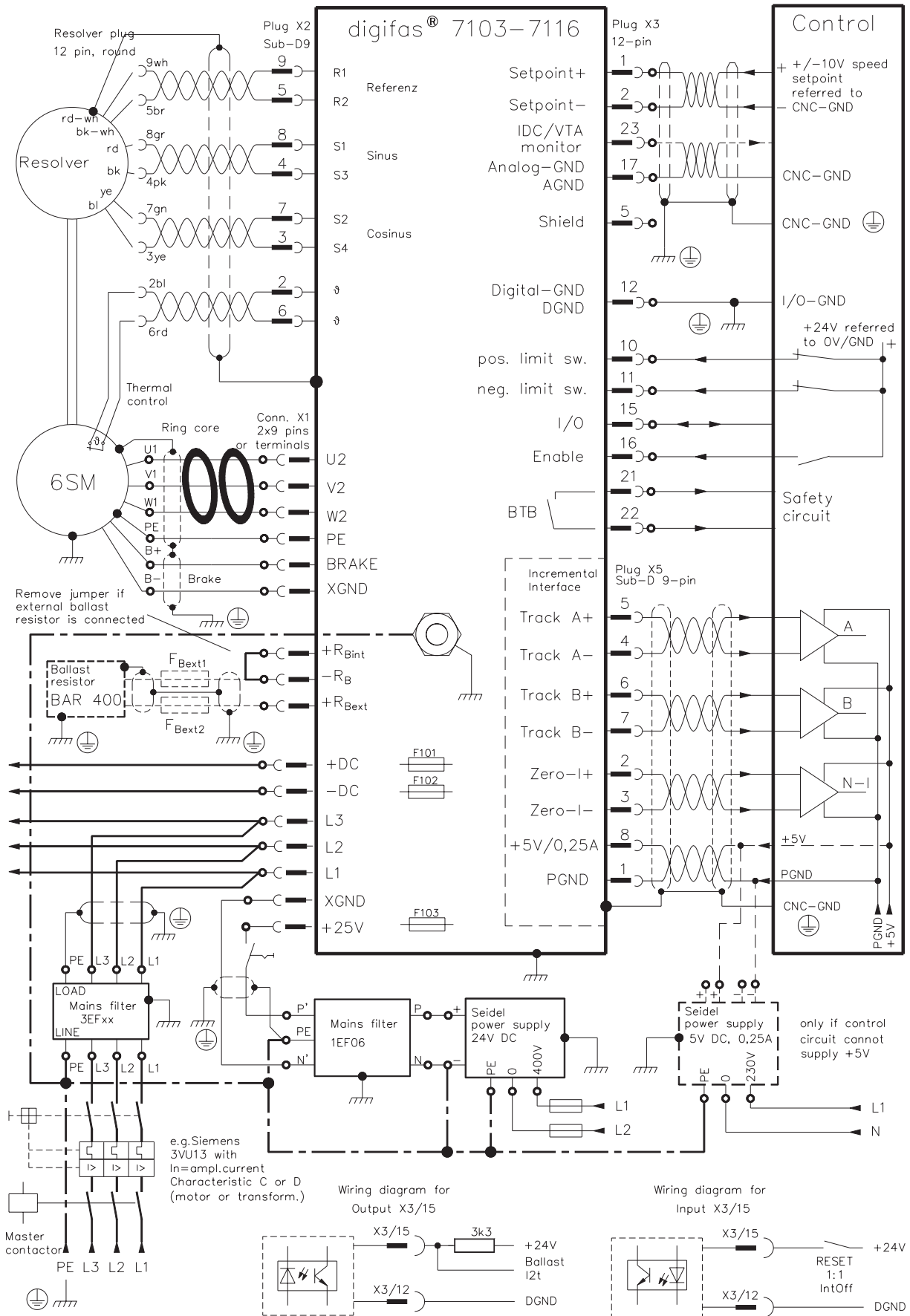

II.2.3 (C) - correct wiring digifas™ 7133 to 7150, general diagram

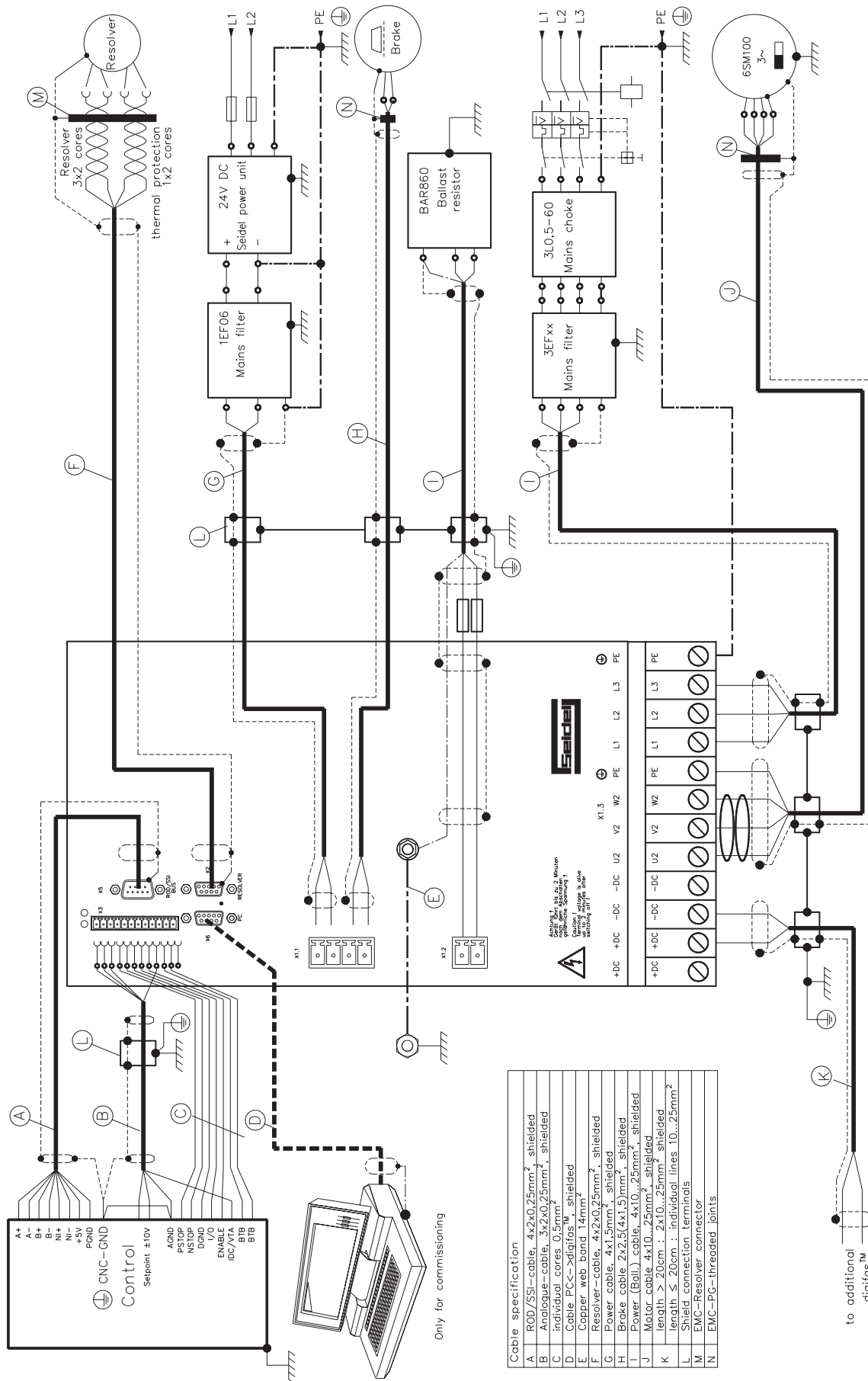

II.2.4 Wiring diagram digifas™ 7133 to 7150 , standard unit

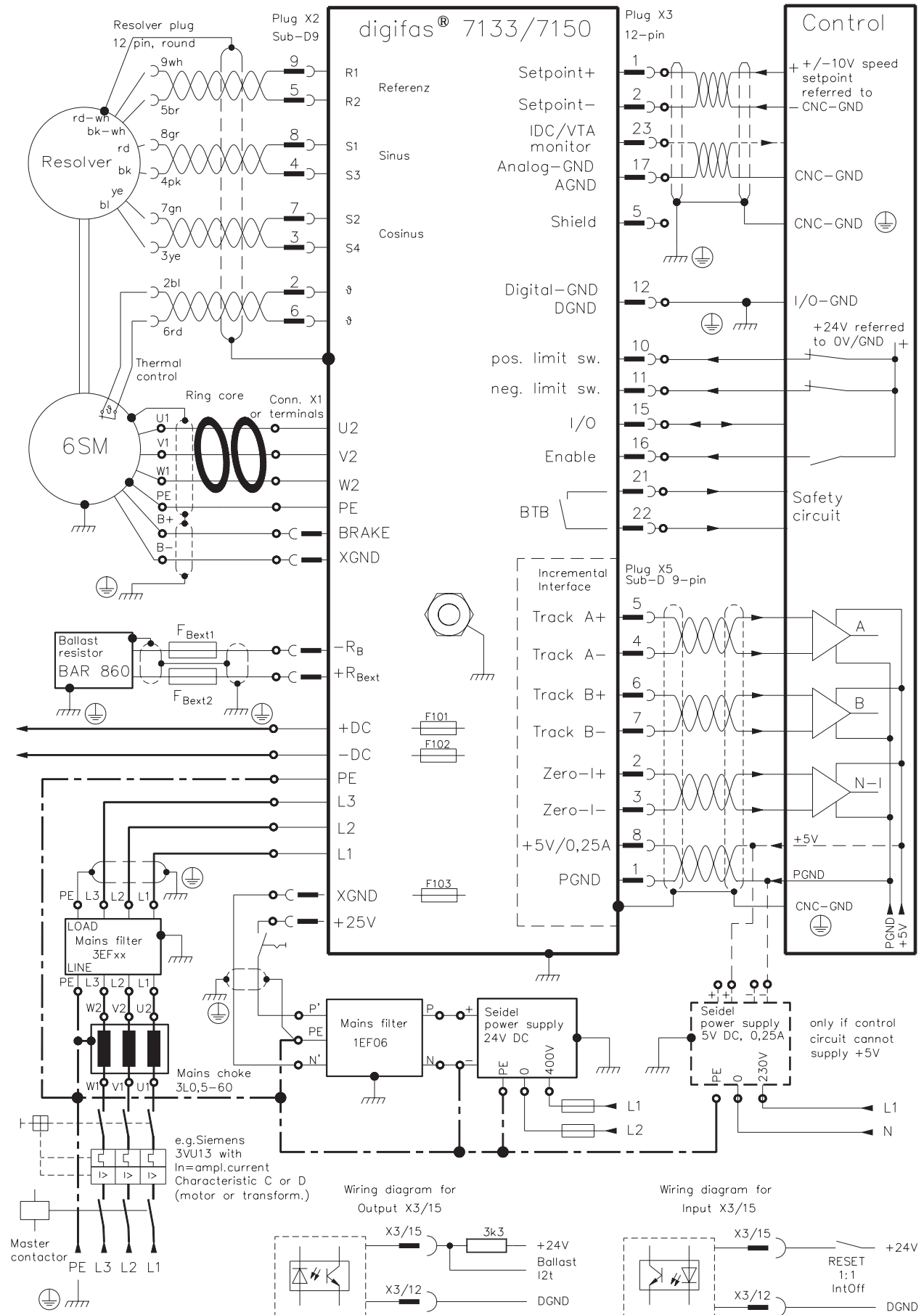

II.2.5 Wiring example: multi-axis system

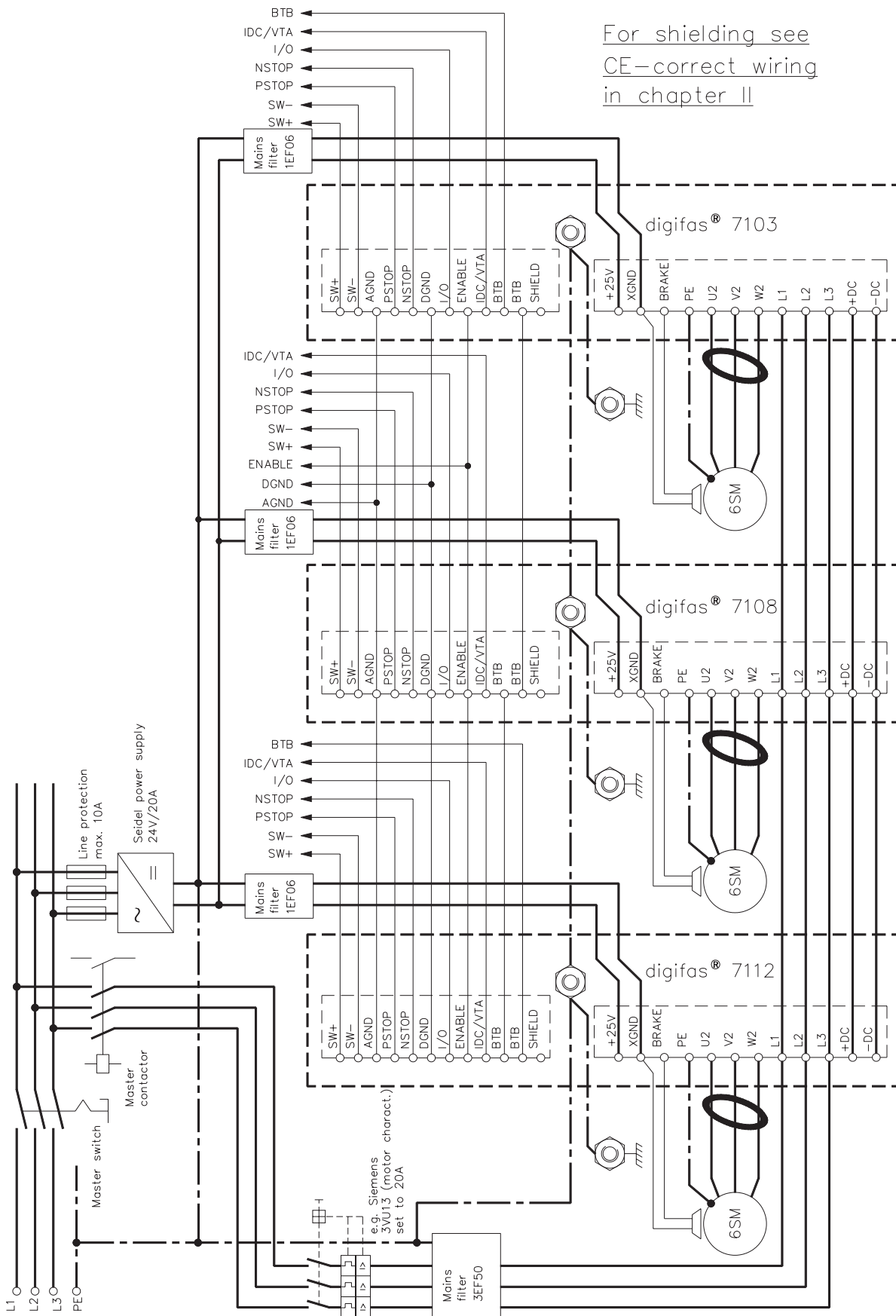

II.2.6 Pin assignments for digifas™ 7103...7116

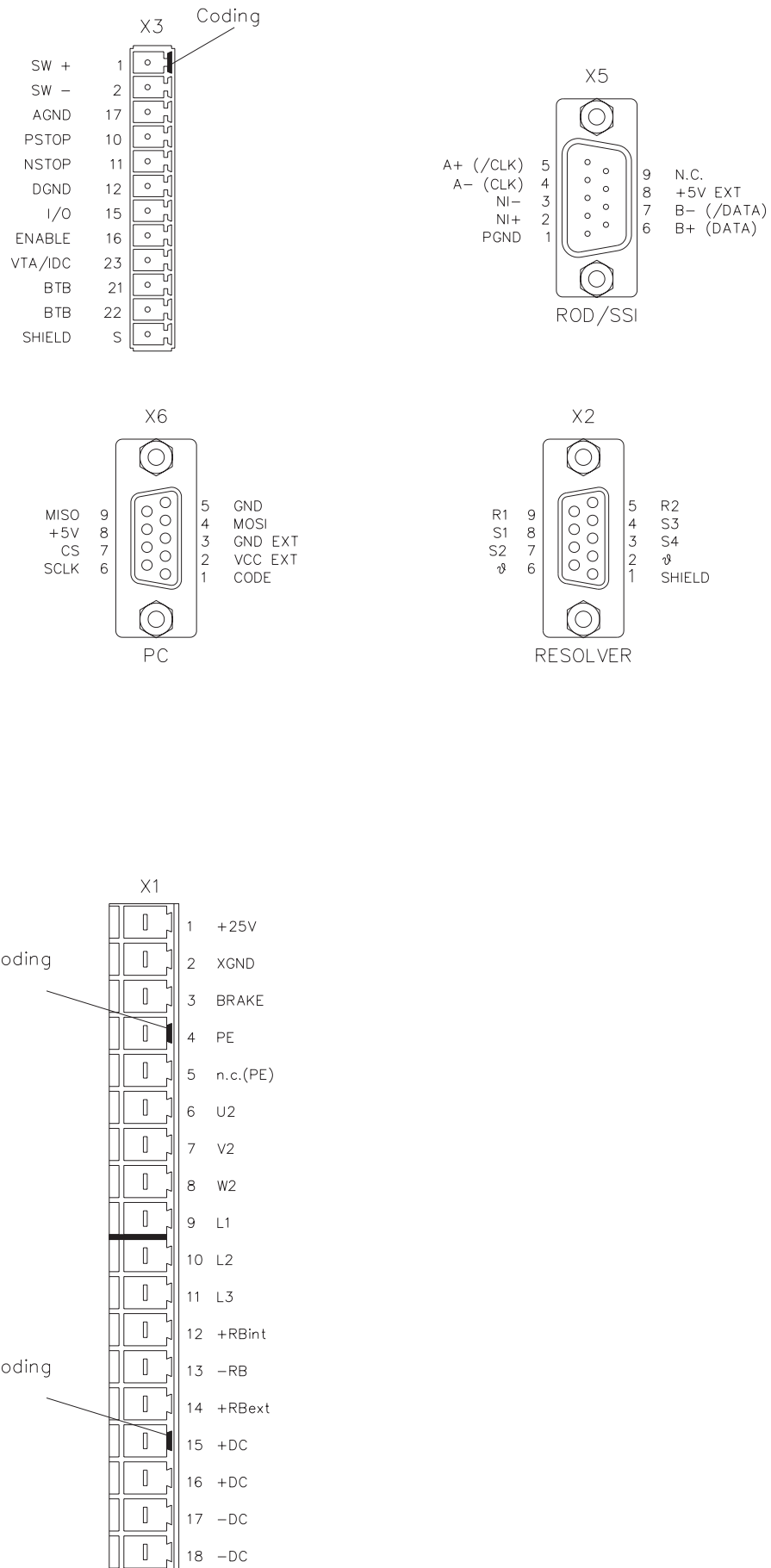

II.2.7 Pin and terminal assignments for digifas™ 7133...7150

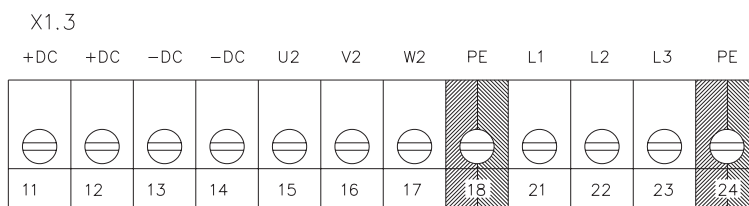
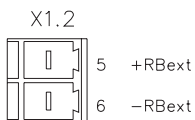
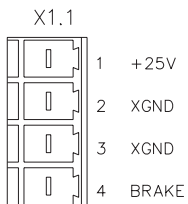
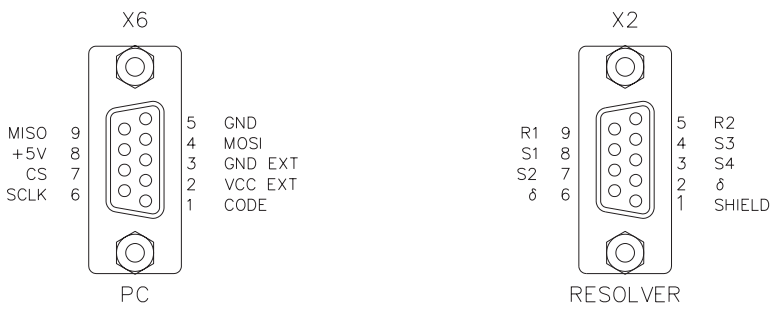
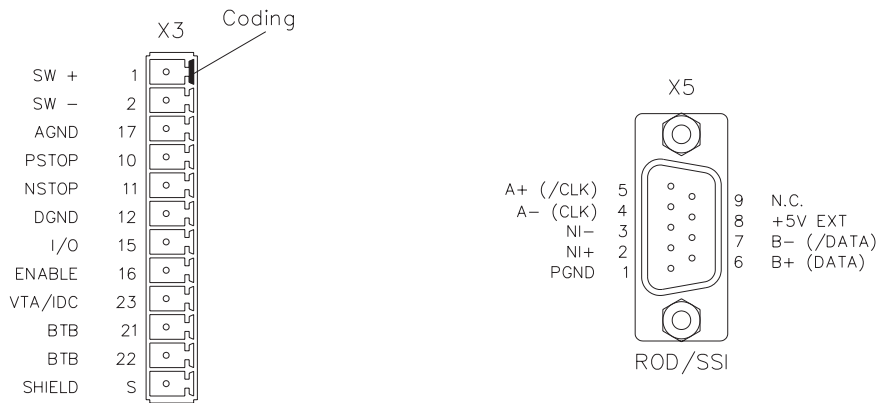

II.2.8 Notes on connection methods

II.2.8.1 Using the shield connection terminal clamps

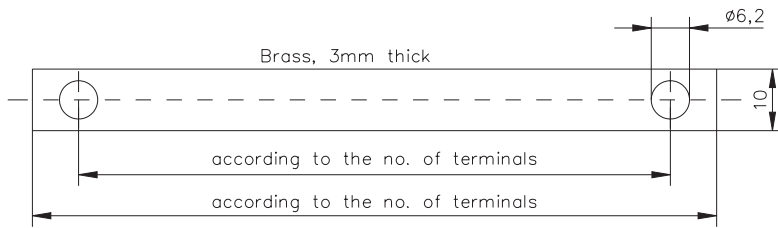

Cut off a busbar of the required length from brass bar stock (10x3mm cross-section) and drill the holes as shown. All the terminal clamps which are needed for connecting the shielding must fit between these drilled holes.

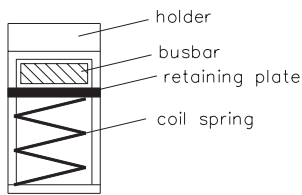

Caution !
Compressed coil springs can be dangerous.
Use pliers or grips.
Compress the coil springs together with the retaining plate and push the busbar through the gap in the holder.

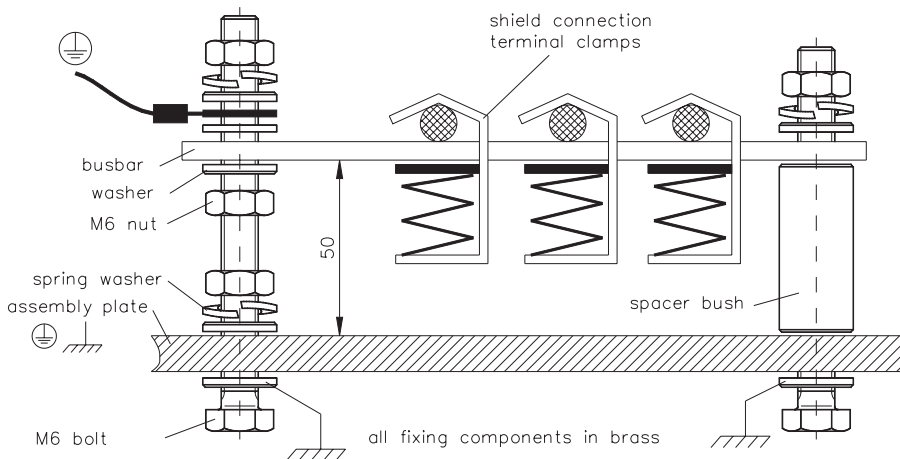

Assemble the busbar, with the shield terminal clamps on it, onto the mounting plate. Use either metal spacer bushes, or bolts with nuts and fittings, to maintain a 50mm clearance. Ground the busbar by means of a single core with at least 2.5mm² cross-section.

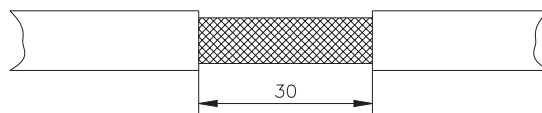

Remove the outer covering of the cable over a length of about 30mm, without damaging the shielding braid. Press up the terminal clamp and insert the cable between the busbar and the terminal clamp. **Make sure that there is a reliable contact between the clamp and the shielding braid.**

II.2.8.2 Connecting the SubD9 connector

Example: resolver connector X2

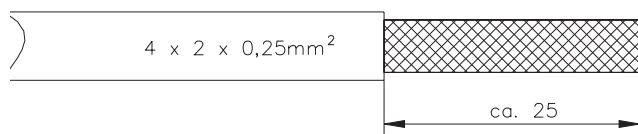

Strip off about 25mm of the outer insulation, taking care not to damage the shielding braid.

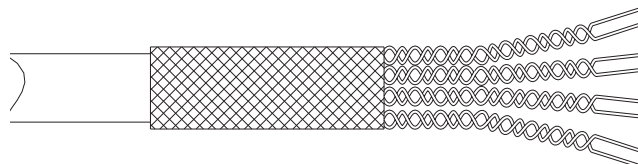

Push the free shielding braid back over the outer insulation.

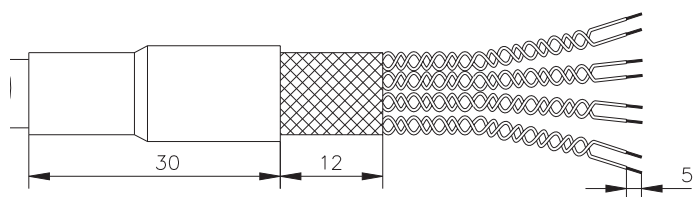

Insulate the back portion with heatshrink sleeving, leaving about 12mm of the braid bare. Strip off the individual cores over a length of 5mm, without damaging the stranded copper.

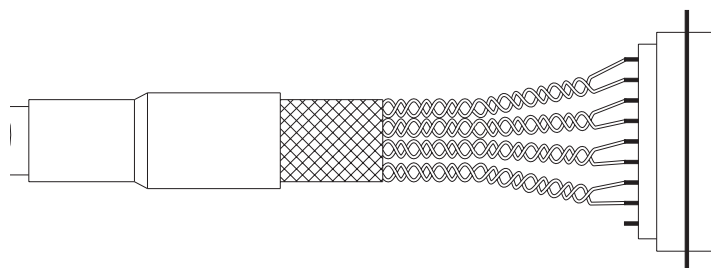

Solder the individual cores into the solder recesses of the SubD plug, according to the wiring diagram in Chapter II.2.2 or II.2.4 (observe the core colours). Check the assignments afterwards.

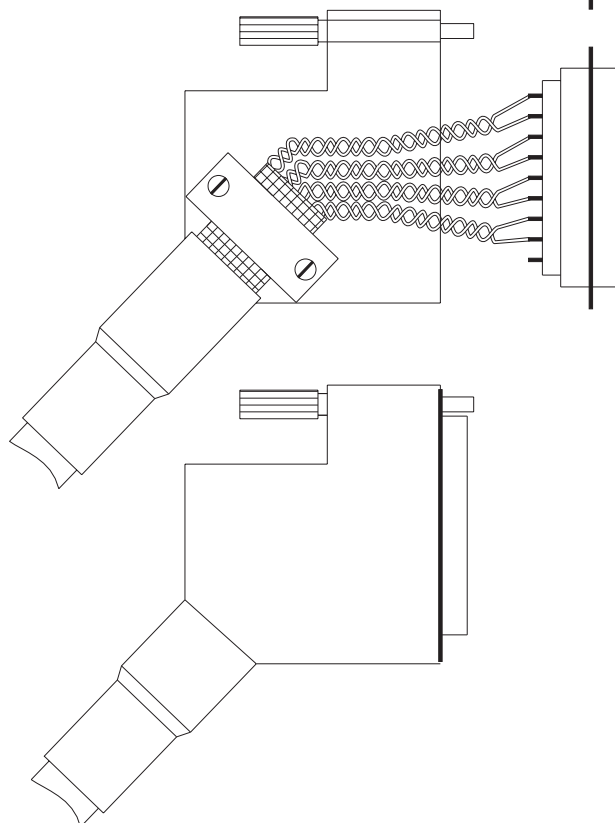

Attach the cable to the plug housing, using the metallic cable grip. The cable grip must seat on the bare shielding braid with a good contact. Place the knurled screw in position.

Note !
When the two halves of the housing have been put together, they cannot be separated again without damage !
Place the SubD plug in the groove of the housing half (pin 1 at bottom) and close up the housing.

II.2.8.3 Using shielded leads with terminals

Example : analog lead

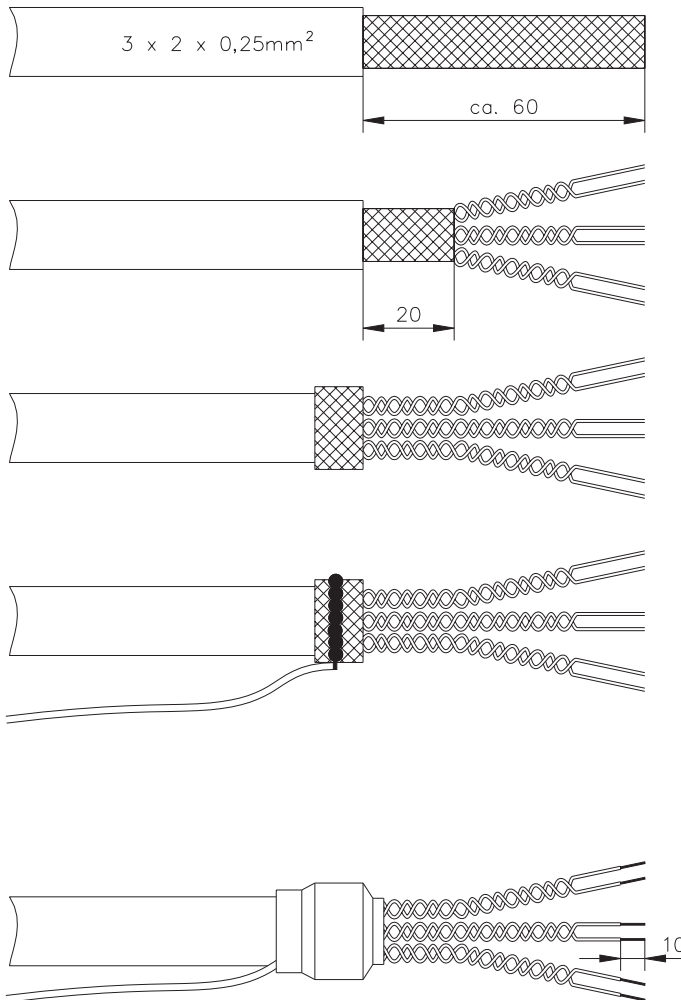

Strip off about 60mm of the outer insulation, taking care not to damage the shielding braid.

Cut back the shielding braid to a length of about 20mm.

Push back the bare shielding braid over the outer insulation.

Shield connection by stranded cable:

Strip off the individual cores (e.g. H05V-K 1mm²). Wind the bared strands around the shielding braid and solder it carefully to the braid, without overheating the plastic outer insulation.

Shielding terminal clamp:

Not applicable, see Chapter II.2.8.1

Strip off the individual cores over a length of 10mm, without damaging the copper strands. Put wire end ferrules over the ends of the cores. Use heatshrink sleeving to insulate the braiding.

Treat all the cables which are to be attached to terminals in the manner described above.

II.3 Commissioning

The commissioning of servo amplifiers can only be carried out by qualified personnel with extensive knowledge of the fields of electrical engineering and drive technology.

The method of commissioning is described in an example. A different method may be appropriate or necessary, depending on the usage of the equipment.

In the case of multi-axis systems, each amplifier must be commissioned individually.



Caution !

Check that all live connection components are protected against accidental contact. Dangerous voltages can occur up to 750V.

Never disconnect the electrical connections of a servo amplifier which is live. The residual charge in the capacitors can still have a dangerous level up to 120 seconds after the mains supply has been switched off.

The amplifier heat sink can reach a temperature of 80°C in operation. Check (measure) the temperature of the heat sink. Wait until it has cooled down to 40°C before touching it.



Caution !

If the servo amplifier has been stored for longer than 1 year, the DC-link capacitors must be re-formed.

In this case, undo all the electrical connections.

Feed the servo amplifier for about 30min from single-phase 230V AC to the terminals L1 / L2. The capacitors will then be re-formed.



Further information on commissioning :

The adjustment of parameters and the resulting effects on the control characteristic are described in the operating manual for the operator software BS7200.

The commissioning of the CONNECT modules is described in the corresponding manual.

More detailed knowledge can be acquired through our training courses (on request).

The following instructions should help you to follow a sensible installation sequence without endangering personnel or machinery.

	check installation	see Chapter II.2. De-energize the servo amplifier.
	disable Enable Signal	0V on terminal X3/16
	switch on 25V aux. voltage	24V DC on terminal X1/1 and ground on terminal X1/2 The green LED light up after the initialisation sequence (approx. 0.5s) (see Chapter I.9.4)
	If the -DISP- option is available, the following step is not required.	
	switch on PC start operator software	See operating manual for the operator software BS7200. The parameters which are stored in the SRAM of the servo amplifier are transferred to the PC.
	check the displayed params. and correct if necessary	<p>Caution !</p> <p>Check the parameters described below especially carefully. If you do not observe these basic values, parts of the system may be damaged or destroyed.</p>
	no. of motor poles	: must match the motor (manual for 6SM motors)
	no. of resolver pole pairs	: must match the motor (manual for 6SM motors)
	IRMS	: maximum is the standstill current I ₀ of the motor (as per nameplate)
	IPEAK	: maximum is 4 x the standstill current I ₀ of the motor
	final speed	: maximum is the rated speed of the motor (as per nameplate)
	ballast power	: maximum is the max. dissipation of the ballast resistor
	check the safety devices	<p>Caution !</p> <p>Make sure that personnel or machinery cannot be endangered by any unexpected movement of the drive.</p>
	switch on mains power	by the ON/OFF switch on the contactor equipment
	setpoint to 0V	without CONNECT module: on terminal X3/1-2, with CONNECT module: function “const. speed” with n = 0min ⁻¹
	Enable	24V DC on terminal X3/16, motor is stopped with standstill torque
	Setpoint	<p>without CONNECT module installed :</p> <ul style="list-style-type: none"> - analog setpoint, recommended 0.5V on terminal X3/1-2 <p>with CONNECT module installed :</p> <ul style="list-style-type: none"> - carry out “REVERSING MODE” function in the “SERVICE” menu, with the given default values (reversing at 100 rpm, change direction every 0.5s) <p>If the motor oscillates, this is dangerous for the motor ! The Kp parameter in the “Speed” must be reduced.</p>
	Optimization	for speed and current controllers, see BS7200 operating manual
	start up CONNECT- module	see corresponding CONNECT operating manual

II.4 Parameter description

A brief description of the parameters is given. Detailed explanations can be found in the operating manual for BS7200.

II.4.1 General

Motor pole no. [-]

The current setpoint entry can be adjusted for operating 2- to 12-pole motors. Changes are only possible when the Enable signal is inactive.

Language [-]

The operator language can be selected from: English, German, French.

Resolver pole-no. [-]

Switches the no. of resolver poles to operate 2/4/6-pole resolvers. Changes are only possible when the Enable signal is inactive.

I/O [-]

Determines the function of the I/O terminal X3/15, see Chapter III.1.2 and III.2.2.

Ballast resistor [-]

Switches between internal and external ballast resistor.

Ballast power [W]

Sets the external ballast power.

Brake [-]

The motor holding brake can be operated from the servo amplifier.

NI-offset [increment]

Only accessible when the interface is set to ROD. Determines the position of the zero pulse within a turn. Input referred to zero crossing of the resolver and the preset resolution

ROD/SSI [-]

Select the type of interface or switch off the interface.

ROD code [-]

Only accessible when the interface is set to ROD. Determines whether the output is in decimal or binary code.

Resolution [Inkr./Umdr.]

Only accessible when the interface is set to ROD. Determines the no. of increments per turn which are output.

SSI code [-]

Only accessible when the interface is set to SSI. Determines whether the output is in binary or GRAY-code.

SSI clock [kHz]

Only accessible when the interface is set to SSI. Determines the SSI clock rate and the quiescent level of the clock line. Setting : 200, 1500, 200 inverted, 1500 inverted.

II.4.2 Current controller

 I_{rms} , root mean square current [A]

Sets the desired rms output current.

 I_{peak} , peak current [A]

Sets the desired peak output current (rms value) according to requirements.

 I^2t threshold, signal threshold [%]

Monitors the actual rms current required.

 K_p , P-gain [-]

Determines the proportional gain of the current controller.

 T_n , integration time [ms]

Determines the integration time constant / integral-action time of the current controller.

II.4.3 Speed controller

 K_p , P-gain [-]

Determines the proportional gain (also known as AC-gain).

 T_n , integration time [ms]

Determines the integration time constant / integral-action time.

PID-T2, second time constant [ms]

Influences the P-gain at medium frequencies.

SW offset [mV]

For the offset compensation of CNC controls and the analog input.

SW ramp + [ms]

Delays the rate of rise of the setpoint value during **acceleration**.

SW ramp – [ms]

Delays the rate of fall of the setpoint value during **braking**.

Speed limit [min^{-1}]

Determines the normalization of the actual value for speed.**DC monitor [-]**

Selects the output of IDC- or VTA-monitor at terminal X3/23.

Limit switch, Stop [-]

The limit switch inputs can be activated or deactivated together or individually.

The Stop function enables a controlled, drift-free standstill with the standstill torque.

Start Phi, phase shift [min^{-1}]

Compensates the inductive phase shift between motor current and motor voltage.

Limit Phi, phase shift [$^{\circ}\text{electr.}$]

The phase shift is increased linearly between the start speed and the final speed up to the final value of Phi.

T tacho, tachometer time constant [ms]

Influences the speed feedback by a low-pass response.

Speed steadiness [-]

Improves the smooth running qualities for drive applications with a constant speed.

II.4.4 Service functions

The service functions are help functions for optimizing the controller parameters.

Constant speed

Drive runs with constant speed. The analog setpoint input is inoperable.

Constant current

Drive runs with constant current, under current control. Actual current is the phase current (combined active and reactive currents). The analog setpoint input is inoperable.

Reversing mode

Drive runs in reversing mode. The analog setpoint input is inoperable.

II.4.5 Display actual value

Ambient temperature

The internal temperature is measured in the servo amplifier and displayed here in °C.

Heat sink temperature

The temperature of the heat sink is measured in the servo amplifier and displayed here in °C.

Intermediate circuit voltage

The intermediate circuit voltage which is produced in the servo amplifier is measured and displayed in V.

I^2t

The momentary effective loading is displayed in % of the preset rms value.

Ballast power

The actual ballast power is measured and displayed in W.

Speed

The actual speed of the motor is displayed in rev min^{-1}

Current: actual value

The momentary value of the rms output current (active component) in A

Rotational angle

Displays the actual rotational angle of the rotor (only for $n < 20 \text{ min}^{-1}$) in °mech and counts, referred to the mechanical zero point of the measuring system.

Operating time

Counts the hours of operation of the servo amplifier.

II.5 Fault signals, BTB signal

All fault messages are signalled by the red collective display LED on the front panel and displayed on the screen or the LCD display.

All faults result in opening of the BTB contact and a switch-off of the output stage.

- undervoltage in intermediate circuit : limit set to 65V by the manufacturer
- overvoltage in intermediate circuit : limit set to 750V by the manufacturer
- output stage fault : fault in the output stage
- mains-BTB : at least two phases of the mains are missing
- aux. voltage fault : internal aux. voltage not correct
- heat sink temperature too high : limit set to 80°C by the manufacturer
- Internal temperature too high : limit set to 70°C by the manufacturer
- motor temperature too high : limit set to 145°C by the manufacturer
- brake fault : short-circuit
- resolver error : cable break or similar

III Control inputs and outputs

III.1 Input functions

III.1.1 Analog inputs

Setpoint input SW

The servo amplifier is equipped with a decoupled differential input for an analog setpoint. It is set for a differential input voltage of max. ± 10 V, resolution 1mV. Ground reference: AGND, terminal X3/17.

A positive voltage on terminal X3/1 with regard to terminal X3/2 produces a clockwise rotation of the motor shaft (looking at the shaft). The common-mode voltage range (important to avoid earth loops) amounts to an additional ± 10 V, input resistance: 20 k Ω .

III.1.2 Digital control inputs

All inputs are **isolated** and coupled via optocouplers. The ground reference is **Digital-GND** (DGND, terminal X3/12). The logic is designed for +24V/7mA (**PLC compatible**), logic-high level is +12 ... 30V / 7mA.

Enable input E

The output stage of the amplifier is enabled by the Enable signal (terminal X3/16, input 24V, **(active high)**). The attached motor is torque-free in the disabled state.

PSTOP / NSTOP (limit switch) inputs

Limit switch positive/negative (**PSTOP / NSTOP**, terminals X3/10 and 11), **high level in normal operation** (fail-safe for cable break). A low signal (open) disables the corresponding direction of rotation, **the ramp function remains active**.

If the inputs are blocked the I-component of the speed controller will also become ineffective, so that a mechanical demarcation (dead stop) is permissible.

This function must be explicitly enabled (parameter LIMIT SWITCH to ON).

If the parameter LIMIT SWITCH is set to STOP, the result is a controlled drift-free standstill of the motor, with the standstill torque M_0 , when the limit switch inputs are disabled (I-component is active).

Programmable input I/O

Terminal X3/15 (I/O) can be programmed by means of the I/O parameter for the following input functions (see Chapter II.2.2 or II.2.4 for a wiring example) :

- **RESET** : hardware reset of the servo amplifier (active high)
- **1:1 CONTROL** : servo amplifier operates purely as a current controller (active high)
- **INT. OFF** : switches off the I-component of the speed controller (active high)
- Ground reference : DGND (terminal X3/12)



Warning !

Do not program terminal X3/15 as an output if it is wired up as an input !

III.2 Output functions

III.2.1 Analog outputs

DC-monitor: armature current setpoint IDC and tachometer monitor output VTA

Depending on the setting of the DC-MONITOR parameter, the IDC/VTA output (terminal X3/23) provides either the current setpoint (IDC) or a tachometer voltage (VTA).

IDC preselection

The IDC monitor provides $\pm 10V$ at \pm **peak equipment current** (sinusoidal rms value) referred to AGND.

The output is the equivalent to the **active** current value, which is approximately **proportional** to the **motor output torque**. Output resistance: 2.2k Ω , resolution: 8bit.

VTA preselection

The output provides $\pm 10V$ referred to AGND at the preset final speed limit.

Output resistance: 2.2k Ω , resolution: 8 bit.

III.2.2 Digital outputs

Ready-to-operate contact BTB

Ready-to-operate (**BTB**, terminal X3/21 and 22, max. voltage 24V DC/42V AC) is signalled via a **floating** relay contact (**100V/0,5A DC**). The contact is **closed** when the amplifier is ready for operation. The signal is **not** affected by the enable signal or the I^2t limit.

Programmable output I/O

Terminal X3/15 (I/O) can be programmed by the I/O parameter for the following output functions (see Chapter II.2.2 or II.2.4 for a wiring example):

- **I2T** : signals that the preset I^2t threshold (high level) has been reached
- **BALLAST** : signals that the preset ballast limit (high level) has been exceeded

Ground reference: DGND (terminal X3/12)



Warning !

Do not program terminal X3/15 as an output if it is wired up as an input !

III.2.3 Brake

A 24V holding-brake in the motor series 6SM27-G to 6SM100-G can be operated directly from the servo amplifier.

The braking function must be explicitly enabled by using the BRAKE parameter: setting WITH. The diagram below shows the timing and functional relationship between the ENABLE signal, speed setpoint, speed and braking force.

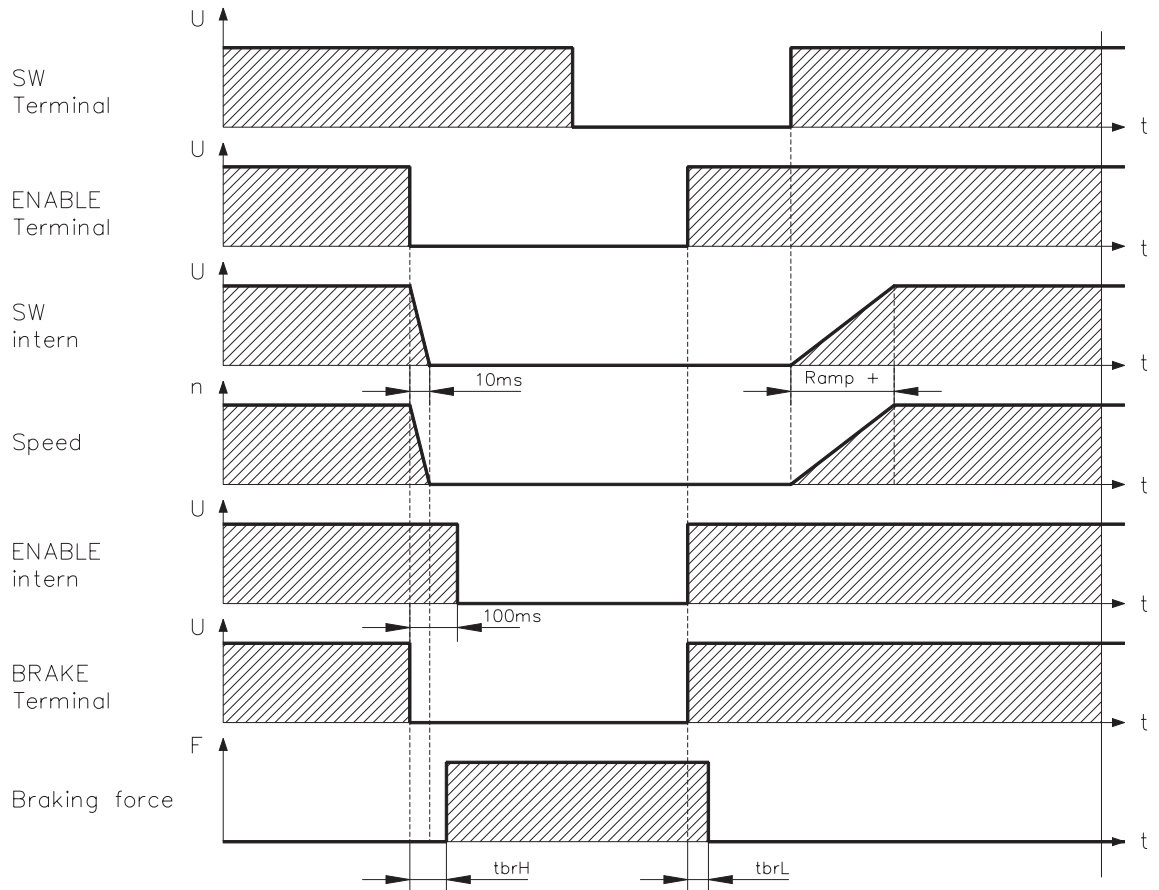

During the internal ENABLE delay time of 100ms the speed setpoint of the servo amplifier is run down to 0V along a 10ms ramp.

The rise and fall times of the holding brake which is built into the motor are different for the individual motor versions of the 6SM series of motors (see the manual for 6SM motors).

This page has been deliberately left blank

IV Interfaces and options

IV.1 Incremental encoder interface (only for units without a CONNECT module)

The incremental encoder interface is included as part of the delivery package for servo-amplifiers which do not have a CONNECT module (standard version).

The position of the motor shaft is calculated in the servo-amplifier from the cyclically-absolute 14-bit information of the resolver digital converter. Pulses are derived from this information which are compatible to the incremental encoder. Two pulse trains (signals A and B) which are electrically offsetted by 90° and a zero pulse are available at the SubD connector.

Set the ROD/SSI parameter to ROD (operator software or operating keys). You can choose between 500, 512, 1000 and 1024 pulses per turn (parameter: RESOLUTION).

The position of the zero pulse can be adjusted over one mechanical turn and stored (parameter: NI-OFFSET). The zero pulse can only be set with A=B=1, so as to maintain compatibility with normal commercial encoders.

The power for the drivers is provided by an external supply voltage (GND: X5.1 and +5V: X5.8). **PGND must be connected to the control.**

Incremental encoder interface : connections and signal definitions

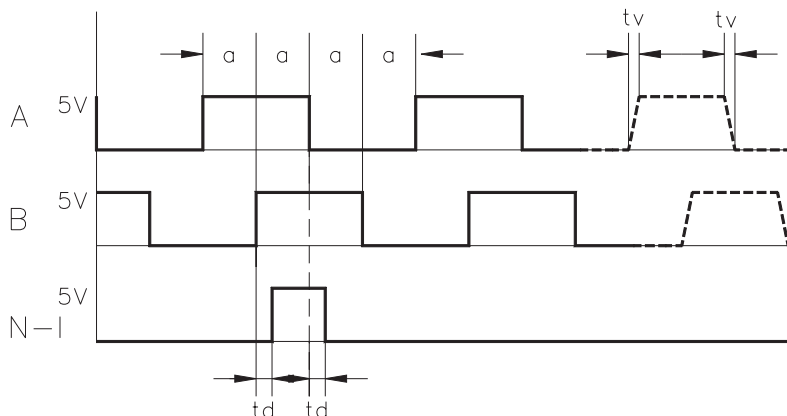
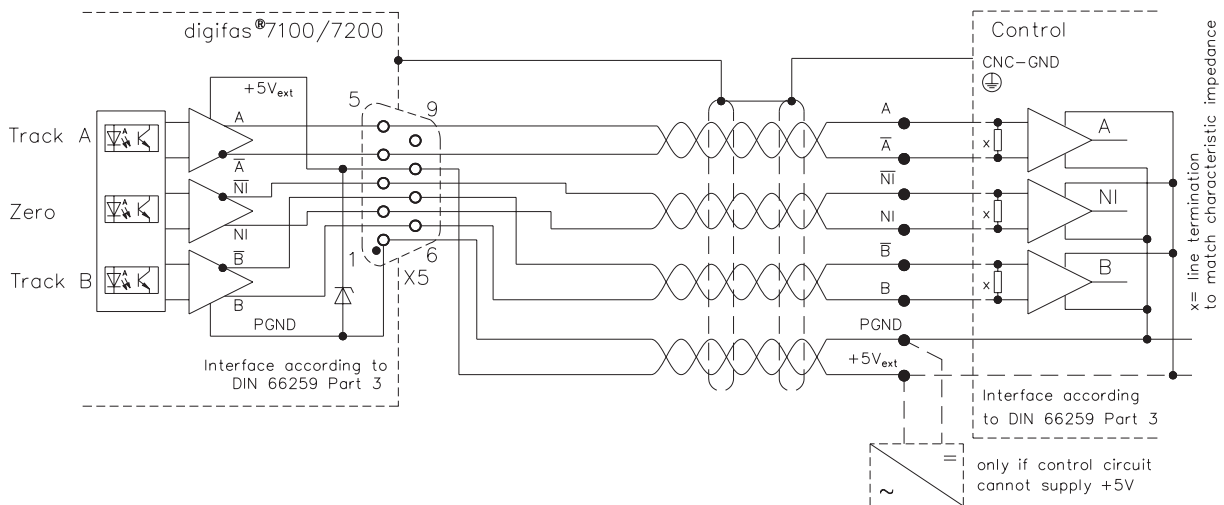

- Edge spacing $a \geq 8 \mu s$
- $U_H \geq 3.7V / -20mA$
- $U_L \leq 0.8V / +20mA$
- Edge steepness $t_v \leq 0.1 \mu s$
- Delay N-I- $t_d \leq 0.1 \mu s$
- Scanning frequency $> 160kHz$
- Limit speed 6000 rpm

IV.2 SSI-Interface, (only for units without a CONNECT module)

The SSI position output is available for servo-amplifiers which do not have a CONNECT module (standard units). Set the ROD/SSI parameter to SSI by using either the operator software or the operating keys.

The signal sequence can be output in **Gray** code (standard) or in **Binary** code. Set the SSI-CODE parameter by using the operator software or the operating keys.

Operate the interface off an external supply voltage (GND : X5.1 and +5V : X5.8).

PGND must be connected to the control.

A serial signal is read out synchronously by the interface at a clock rate of max. 1.5 MHz. You can adapt the servo-amplifier to the clock frequency of the SSI evaluation by using the SSI-CLOCK parameter (200 kHz or 1.5MHz and reversed).

The position of the motor shaft is now calculated from the cyclically-absolute 14-bit information of the resolver digital converter. A position output which is compatible to the usual data format for normal commercial SSI absolute encoders is generated from this information. This synchronous, serial, cyclically-absolute 12-bit information is output on the SubD connector X5.

24 bits are transmitted. The most significant 12 bits are permanently set to ZERO, the least significant 12 bits contain the position output. The interface has to be read like a multi-turn encoder, but supplies valid single-turn data.

SSI-Interface: connections and signal definitions:

The count direction for the SSI interface is set to be upwards for clockwise rotation, looking along the motor axis.

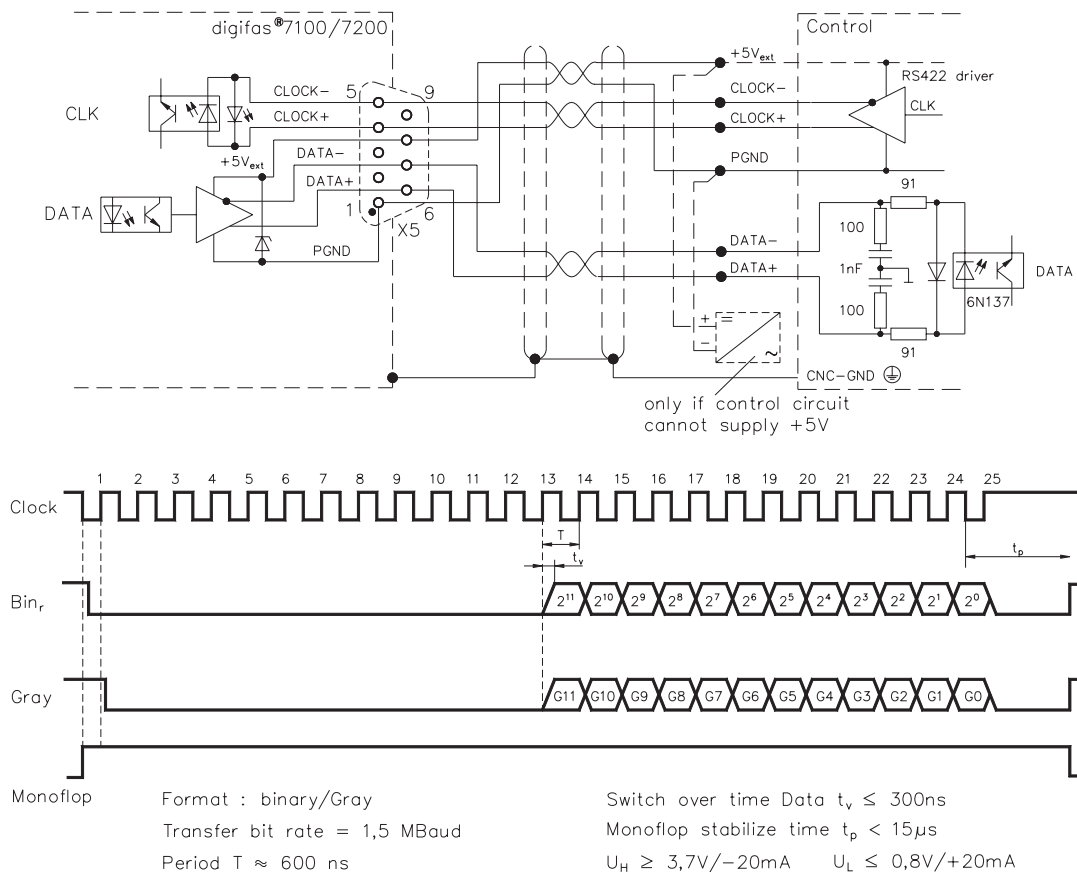

IV.3 PC interface

With the operating software BS7200 you can carry out the setting of the operating, positional, and motion parameters, using a normal commercial personal computer (PC).

While all supply voltages are switched off, use the special 9-core interface cable to connect the PC interface (X6) of the servo amplifier to a serial or parallel port of the PC. The interface in the servo amplifier is electrically isolated by optocouplers.

Connection to a parallel port :

Use our 9 pole parallel interface cable

Connection to a serial port

Use our 9 pole serial interface cable with external power supply.

The minimum requirements for the PC are as follows:

Processor	:	80386 or higher
Clock	:	16 MHz or higher
Operating system	:	MS-DOS (3.3 or higher)
Graphics card	:	VGA
Monitor	:	s/w or colour
Drive	:	3.5" diskette drive, hard disk
Interface	:	one free port (COM1, COM2, LPT1 or LPT2)
		LPT1 : Adress 378_H COM1: Adress 3F8_H
		LPT2 : Adress 278_H COM2: Adress 2F8_H
System (config.sys):	Buffers	: 30 or higher
	Files	: 30 or higher
	Stacks	: 0,0 or not defined
	environment	: the size must be set (/E:xxx) to 1024 bytes or higher with the following syntax :
		shell = command.com /E:1024

Further advice can be found in the manual for the BS7200 operating software.

IV.4 Key control / LC display, Option -DISP-



Only possible for units without a CONNECT module.

When the -DISP- option is installed the parameters for the servo amplifier can still be set with the aid of a PC, using the BS7200 operator software. In this case the -DISP- option is disabled.

When the supply voltage has been switched on, the status indication of the servo amplifier appears in the display. The flashing star indicates the operational readiness of the micro-processor. The type of controller is shown in the second line.

With the built-in **-DISP- option** the amplifier can be operated by digital key entry under operator control, with a 2x16 character clear-text liquid-crystal display.

The servo amplifier can be operated by three keys:





IV.4.1 Key description / operation



The upper key  is comparable to the ESCAPE and Cursor Up keys of a personal computer. As you move around within the menu structure you can access the next higher menu level by using this key. For numerical entries, a single short tap on the key will increase the present value by 1. If you keep the key pressed down the value will be counted up, slowly at first, then rapidly, up to the permitted maximum.

The middle key  has the same function as the Cursor Down key in a personal computer. You move down the menu with it, and when you have reached the last menu item it will jump to the first one again. For numerical entries, a single short tap on the key will reduce the present value by 1. If you keep the key pressed down the value will be counted down, slowly at first, then rapidly, down to the permitted minimum.

The bottom key  has a function which is similar to the ENTER key of a personal computer. By operating this key you switch to the menu item which has been selected. If a parameter is displayed, then this key will start the entry mode. After the parameter has been set you press this key to transfer the value to the memory.





Moving round the menu

From the status display, you can use the middle key  to access the first item in the menu. With the  key you can leave this menu level and get back to the status display.

For each menu item, you can use the key  to access the first parameter which can be set and, using key  step through the parameter list. With  you can jump back to the menu level.

The next menu item is accessed by using the  key.

Altering parameter values

When a parameter is displayed, use the entry key  to access the entry mode. The parameter will now appear with an underline. With the key  or  you can alter the value. Using  transfers the value to the memory.

Service functions

The service functions “**CONSTANT SPEED**” and “**CONSTANT CURRENT**” are active after the corresponding parameter value has been entered, as long as  is kept pressed.

The service function “**REVERSING MODE**” is activated as soon as you are in entry mode for this service function. You are now able to optimize the servo amplifier (all the parameters which can be set on-line) during reversing operation, so long as you do not leave the menu level. As soon as you leave the menu, reversing mode is terminated and the status is displayed .

IV.4.2 Menu structure and operation

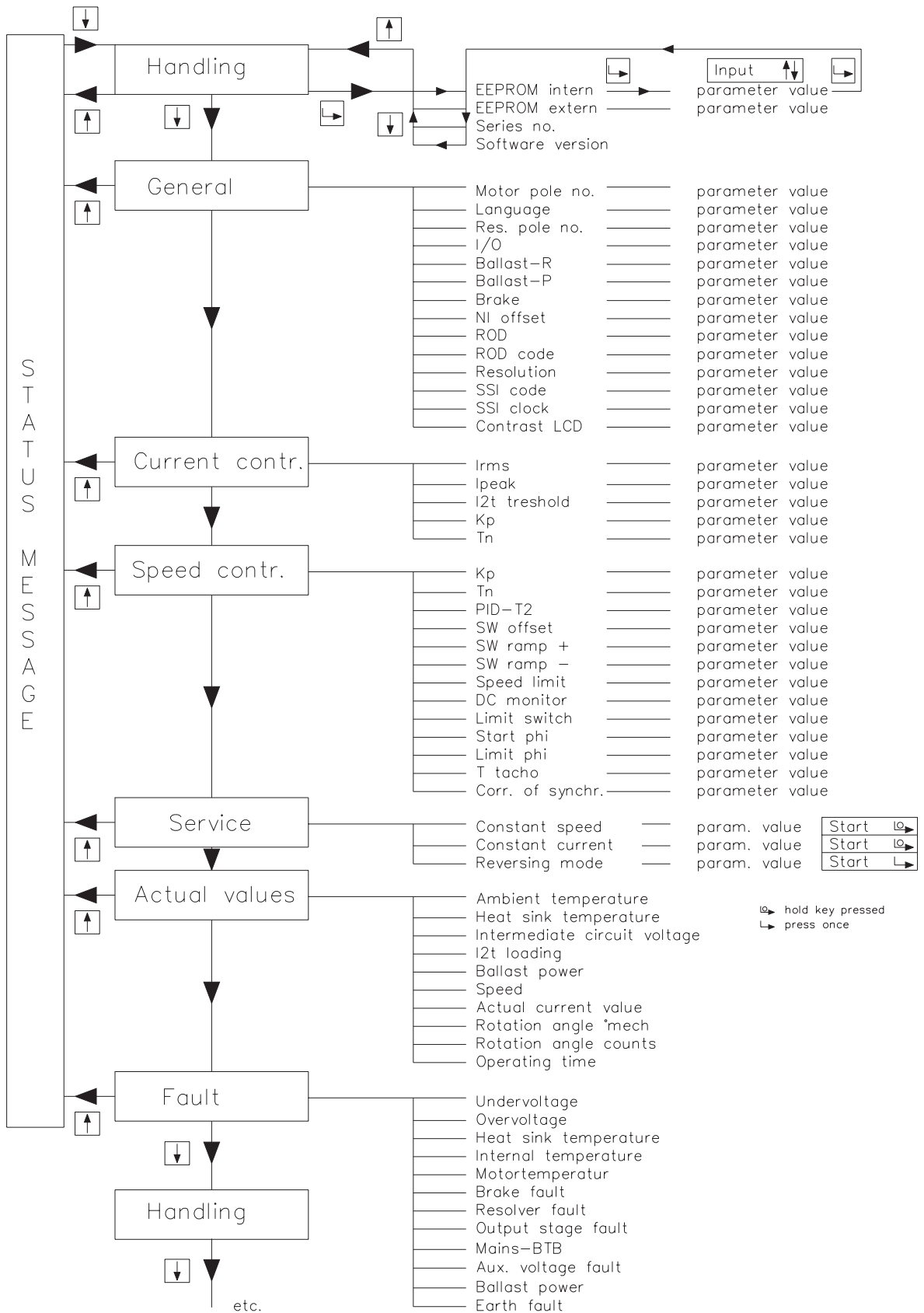

IV.5 Controllable torque limiting, Option -IL-



Only possible for units without a CONNECT module.

IV.5.1 General, technical data

With the -IL- option you can limit the torque of the motor which is connected to the digifas™ to a freely selectable value which is less than the pulse torque, with the aid of a DC control voltage. This is achieved by changing the current setpoint by means of an external analog speed-control loop.

The electronics is contained in a separate casing.

Assembly	:	— on top-hat rails EN 50022-35 or C-rails, in the immediate vicinity of the servo amplifier	
Dimensions	:	— H x W x D (without top-hat rail) : 111 x 145 x 90	
Connections	:	— two 8-pin Combicon connectors for control signals, setpoints and auxiliary voltages — SubD 9-pin socket for pulse encoder signals from digifas™ — SubD 9-pin plug to transfer the pulse encoder signals to higher-level controls	
Inputs	:	— 2 differential amplifiers for 2 speed-setpoints $\pm 10V = \pm$ final speed SW1 fixed, SW2 can be decreased by P302, both SW are added — 1 differential amplifier for current limit 0 ... 10V — aux. supply voltage +25V DC/ 210 mA, XGND — enable via optocoupler, DGND — pulse encoder signals from digifas™ , PGND	
Outputs	:	— current setpoint $\pm 10V$, AGND — aux. voltage +10V DC/ 5mA, AGND — pulse encoder signal for control via optocouplers, PGND	
Potentiometer	:	— P302	: to reduce setpoint 2 0 ... 100%
		— P303	: offset (speed drift) $\pm 10mV$
		— P304	: fine adjustment of speed $\pm 12\%$
		— P305	: AC gain (P-gain) 3 ... ∞
Solder link LB1	:	— open	: final limit speed 3000 rev/min (standard)
		— closed	: final limit speed 6000 rev/min
LEDs	:	— display the logical state of the pulse encoder signals	
Fusing	:	— F1, 630 mA, to protect the aux. supply voltage	

IV.5.2 Important notes

Connect up the unit according to the wiring diagram in Chapter IV.5.5.

The unit is supplied from the auxiliary voltage (terminals +25V, XGND) which is also available in the servo amplifier. Internally, this is electrically connected to the analog ground (AGND). There is an internal fuse for the positive pole. Both poles are decoupled via HF chokes.

If you want to use the pulse encoder signals in the control system, then the driver circuitry on the option board must be provided with a 5V supply (see Chapter IV.5.5).

The analog speed controller is normalized for 1024 pulses / turn. You can use the soldered link LB1 to set the speed controller to a final limit speed of 3000 rev/min (LB1 open) or 6000 rev/min (LB1 closed).

Close all the hardware limit switches in the higher-level control and combine the signals in an AND function. Join the servo amplifier inputs PSTOP and NSTOP together (see Chapter IV.5.5). Connect the output of the AND function to the joined inputs PSTOP/NSTOP.

In order to be able to drive away from an activated limit switch, the controller must produce a speed setpoint value with the correct polarity sign for traversing away from the activated limit switch and then 24V must be applied to the bridged limit switch.

In the event of an overload of the servo amplifier, the effective current limit within the servo amplifier (I^2t) remains active.



Caution !

The drive can run away if the pulse encoder cable from the servo amplifier to the IL module is interrupted (e.g. by mechanical damage to the cable).

Take account of this in the controller program.

The following table shows the relationship between the applied current limit I_{lim} and the current setpoint I_{setp} which is produced:

Current limit input I_{lim}	negative voltage	open	0 ... +10V
Current limit output I_{setp}	0.3 % I_{peak}	0.3 % I_{peak}	0.3 ... 100 % I_{peak}

If the enable input is not controlled, then the result is always $I_{setp} = 0.3 \% I_{peak}$.

IV.5.3 Commissioning

Our applications department can help you with commissioning.

Preparation

- switch off the supply voltages
- detach plug X4 from the servo amplifier
- check LB1 (final speed), change solder link if necessary
- set enable signal to 0V
- switch on aux. voltage 25V DC and PC, start operator software BS7200

Setting parameters

- set parameter “ROD resolution” to 1024 incr./turn
- adjust parameter “Final limit speed” to the setting of LB1
- set parameter “I/O” to 1:1 control
- set parameter “Ramp +” to 2ms
- set parameter “Ramp -” to 2ms
- store the parameter set in the EEPROM
- switch of the 25V DC aux. voltage

Optimization

- connect plug X4 to the servo amplifier, switch on the voltages
 - optimization : offset adjustment with potentiometer P303
 AC gain adjustment with potentiometer P305
- continue in the same way as the corresponding description in the BS7200 manual.

IV.5.4 Position of the connectors and control elements

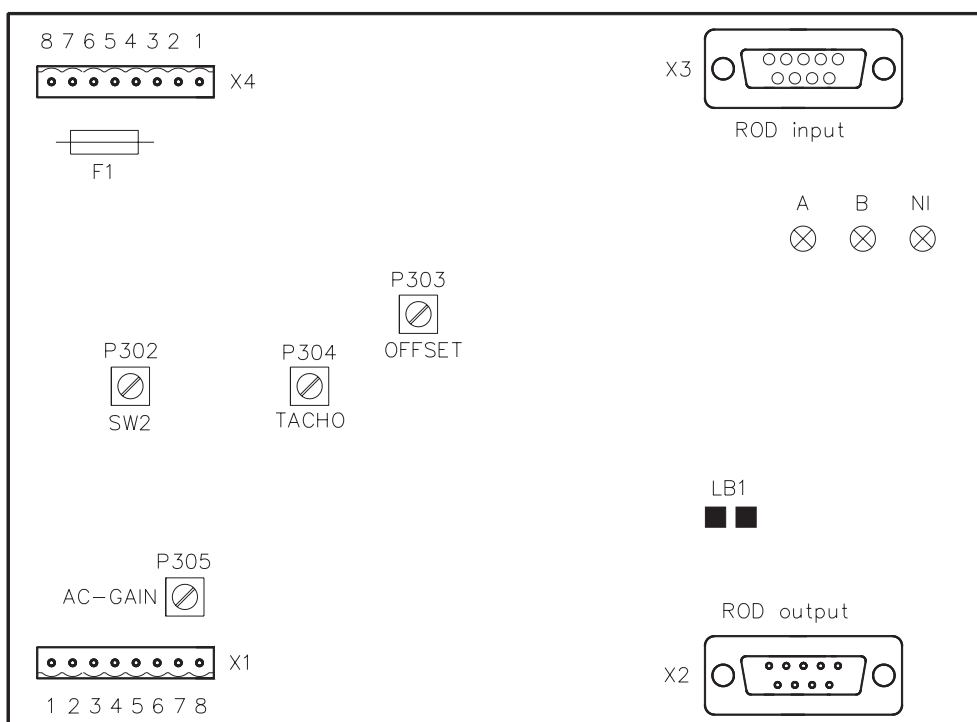

IV.5.5 Wiring diagram, -IL- option

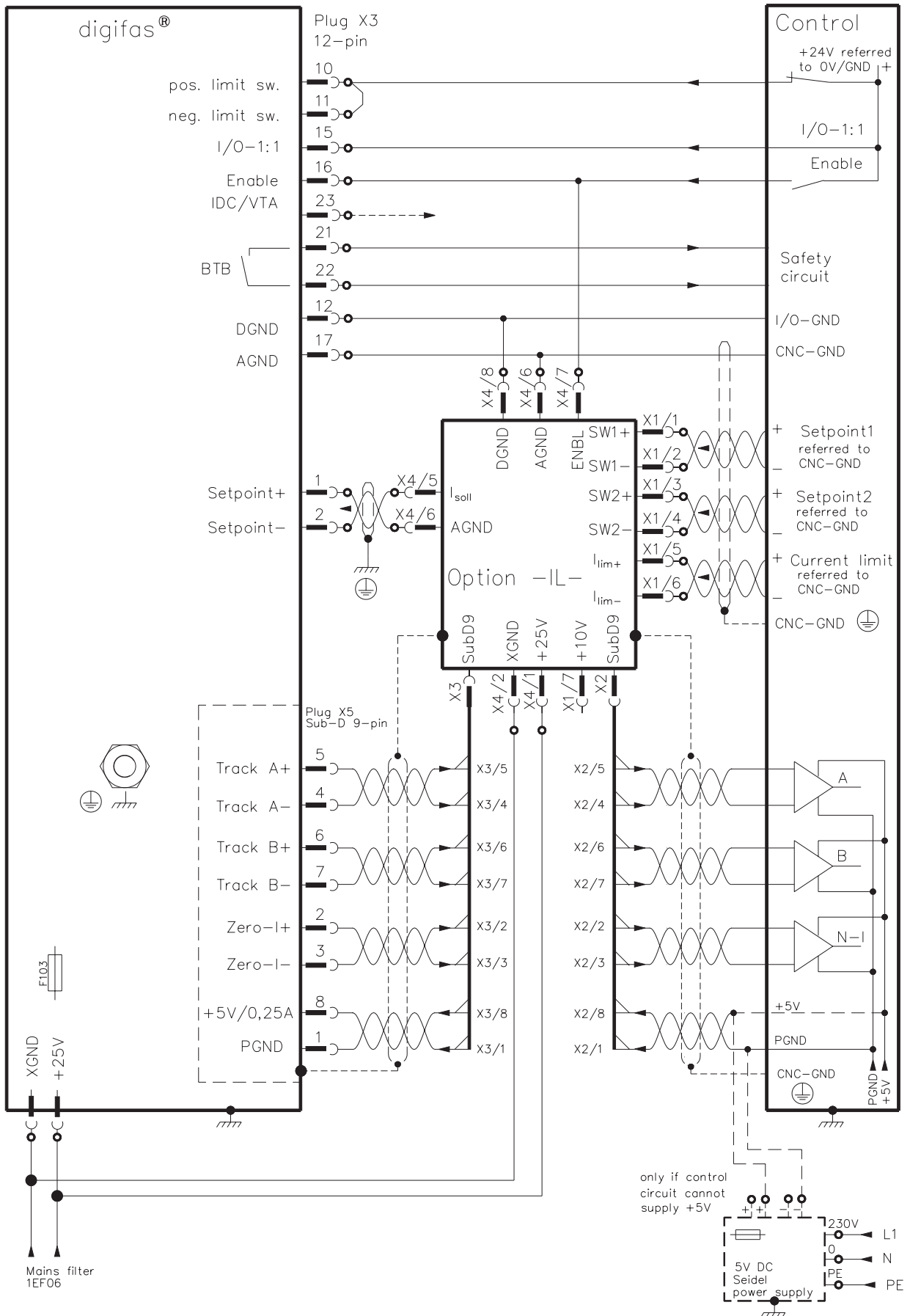

This page has been deliberately left blank

V Drawings

V.1 Resolver cable for the 6SM series of motors

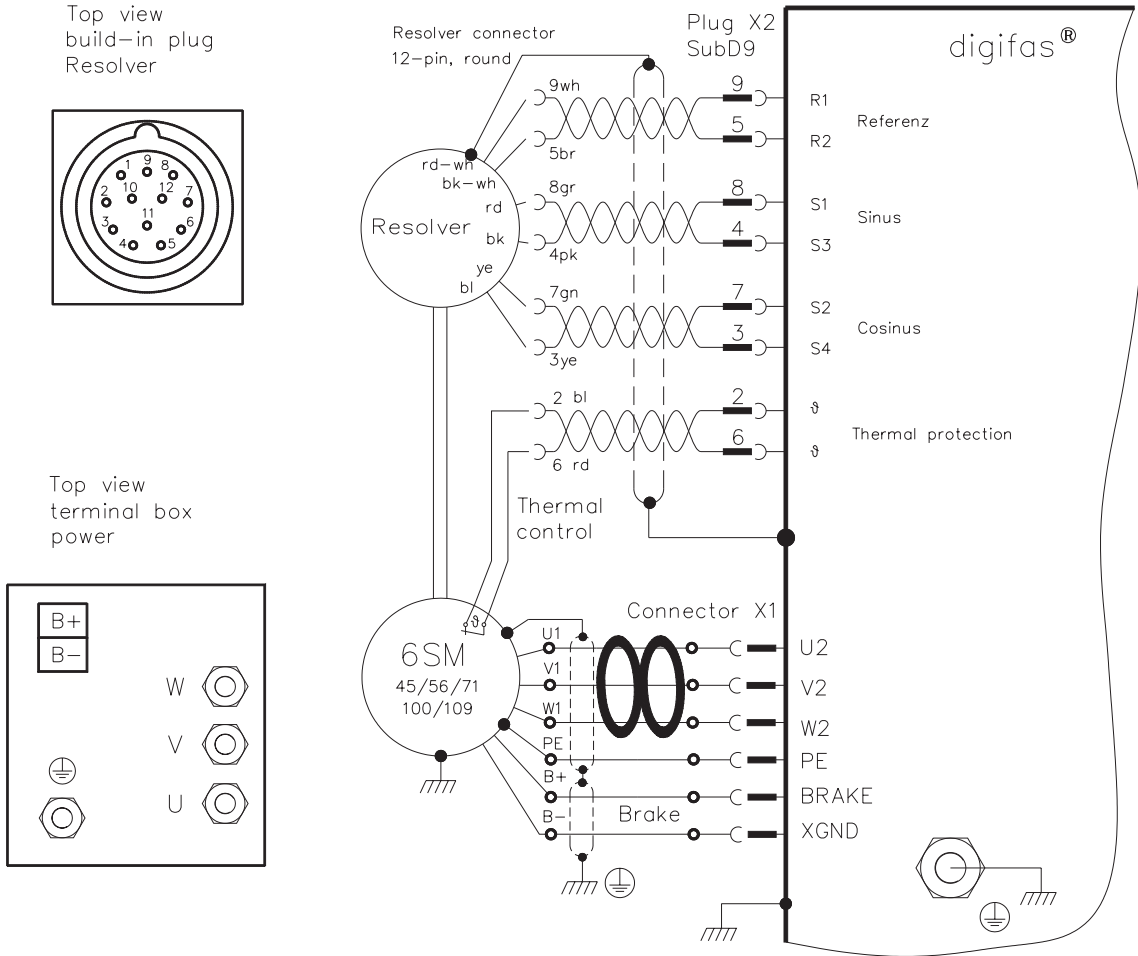

12-pin connector
(Mat.-No.: 85080)

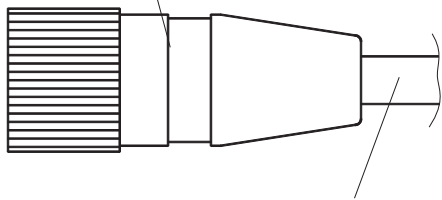

4 x 2 x 0,25
shielded, twisted pairs
on request max. 100m

Sub-D connector 9-pin
(Mat.-No.: 81783)

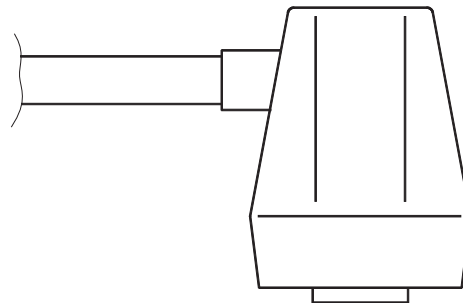

Length	Mat.No.
5m	84972
10m	84973
15m	84974
20m	84975

Res. cable f. 6SM
with connector
longer cable on request

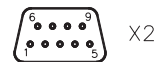

V.2 Analog input and output circuits

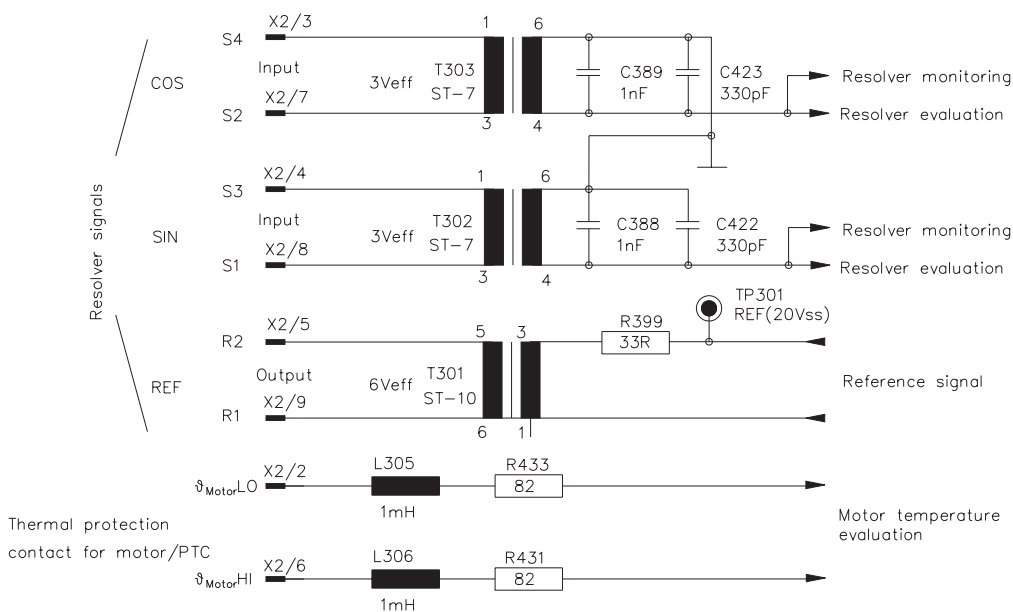
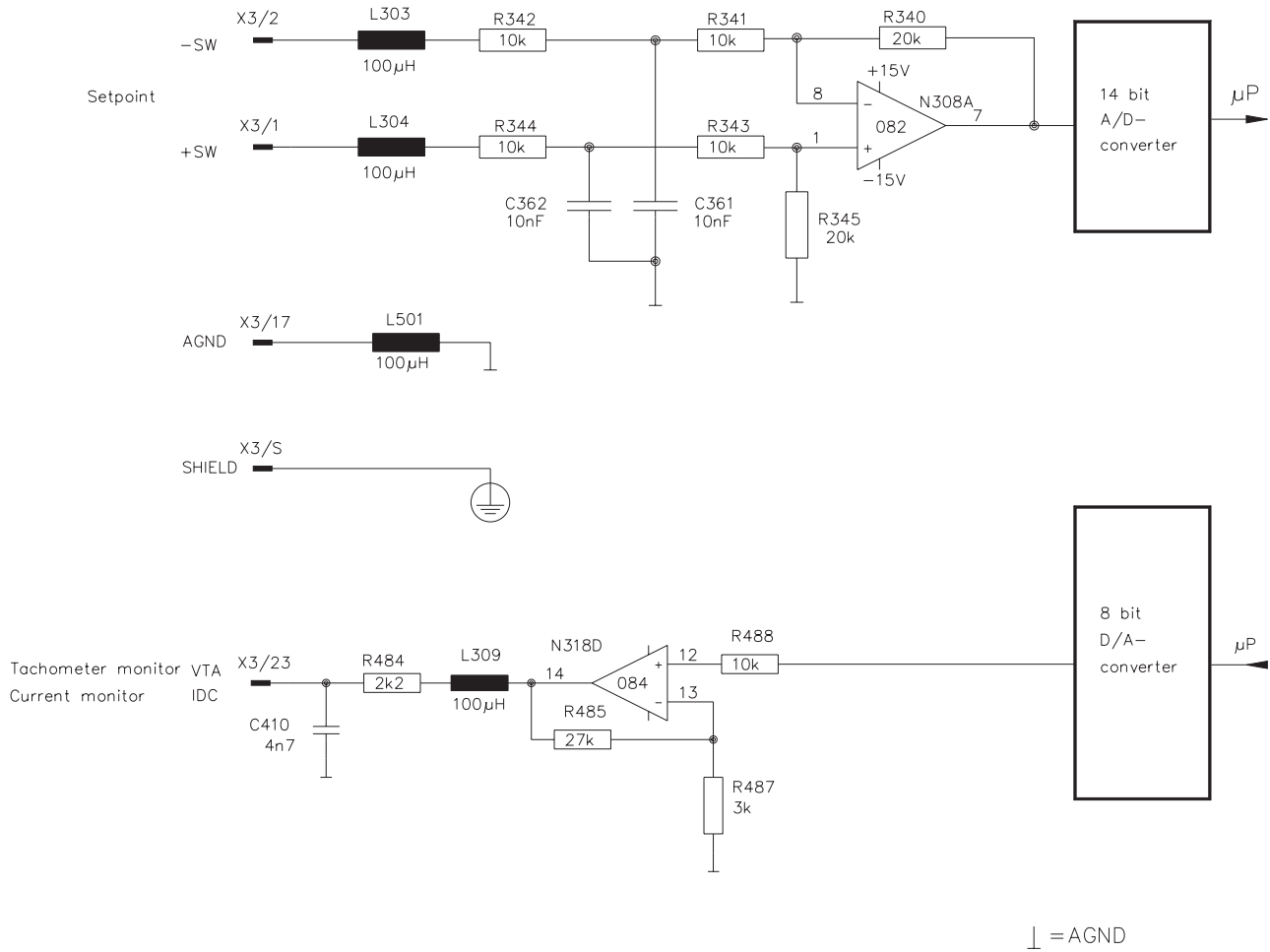

V.3 Digital input and output circuits

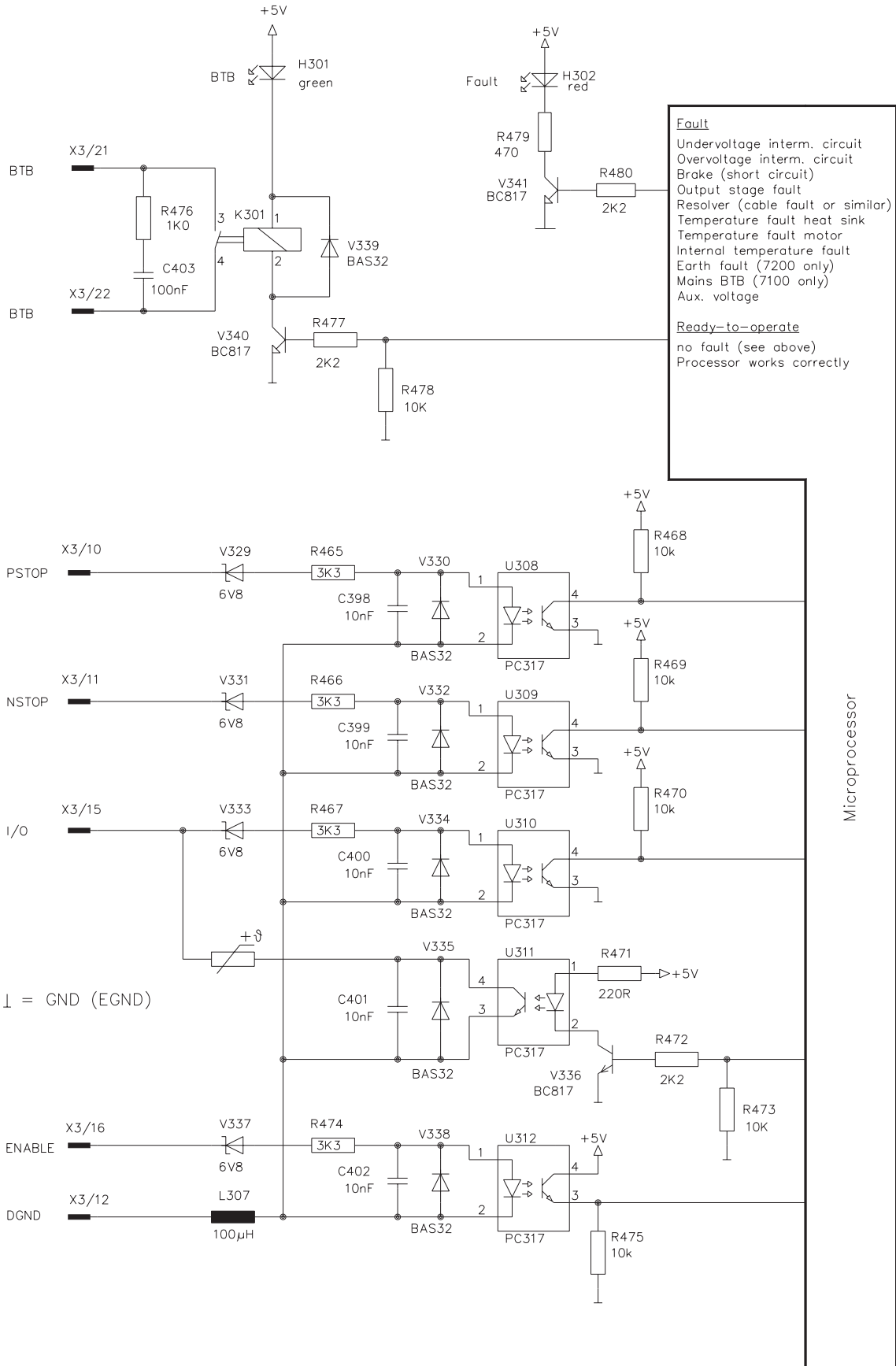

V.4 Assembly levels and dimensions for digifas™ 7103...7116

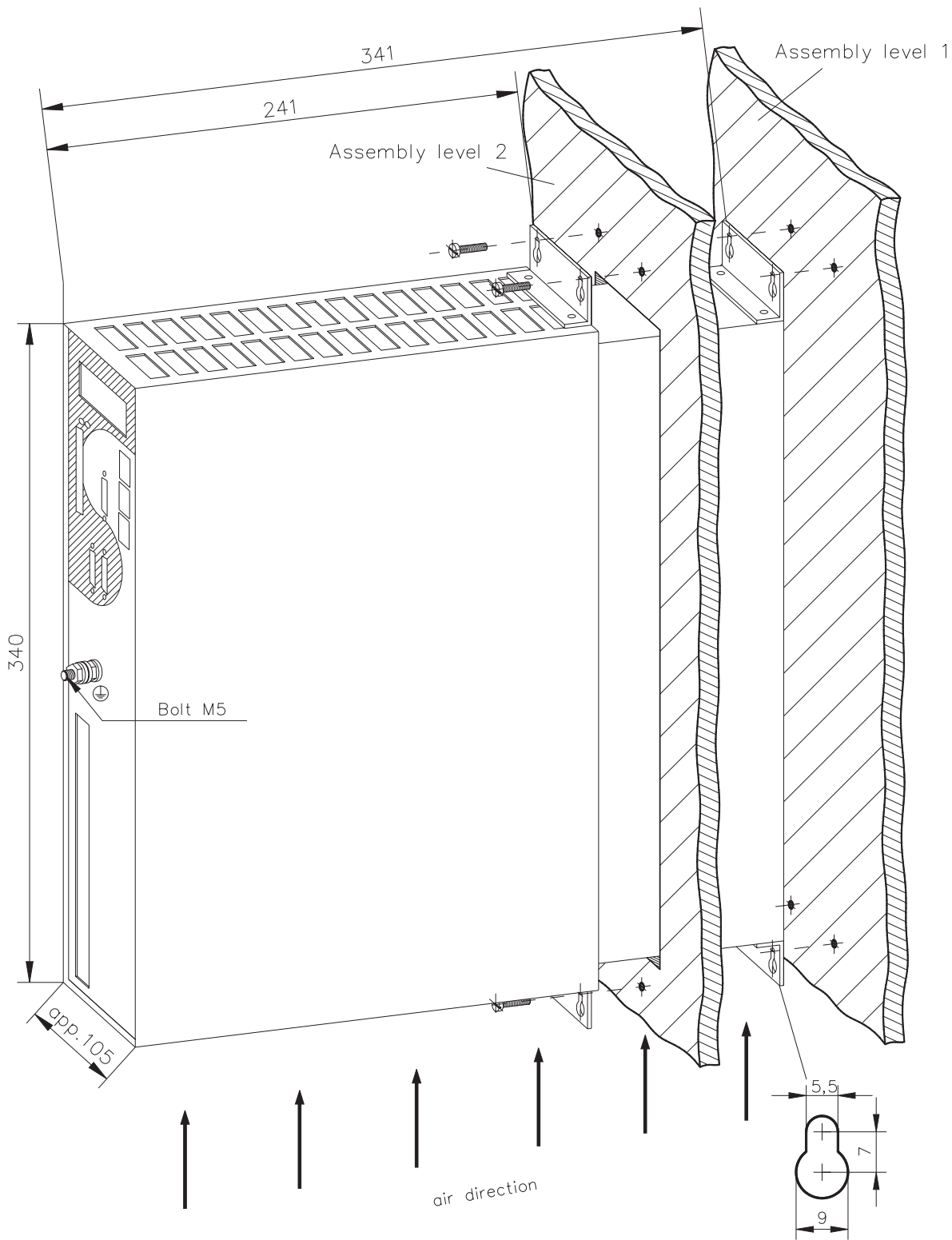

M5 bolts are used for fastening

V.5 Installation of digifas™ 7103...7116 in a switchgear cabinet

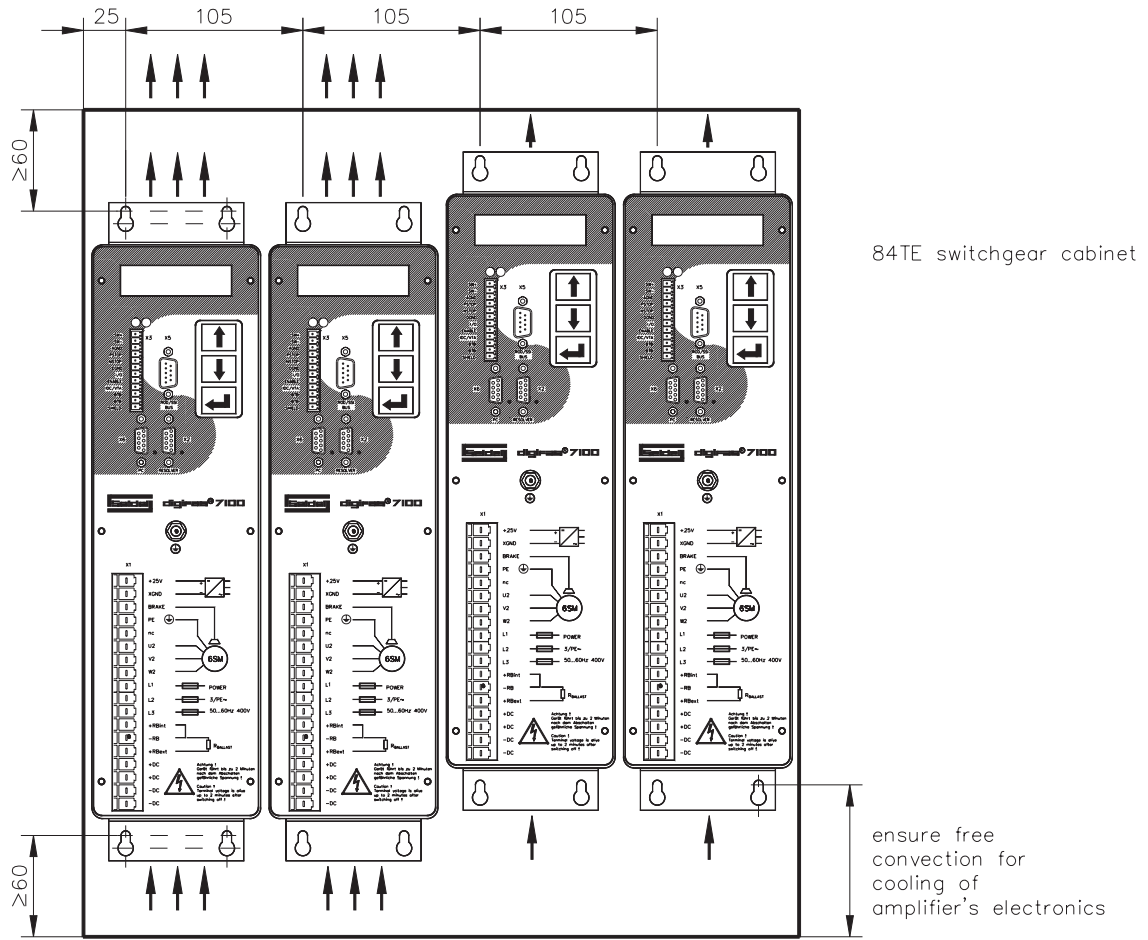

Assembly level 1
(heat sink in cabinet)

Assembly level 2
(external heat sink)

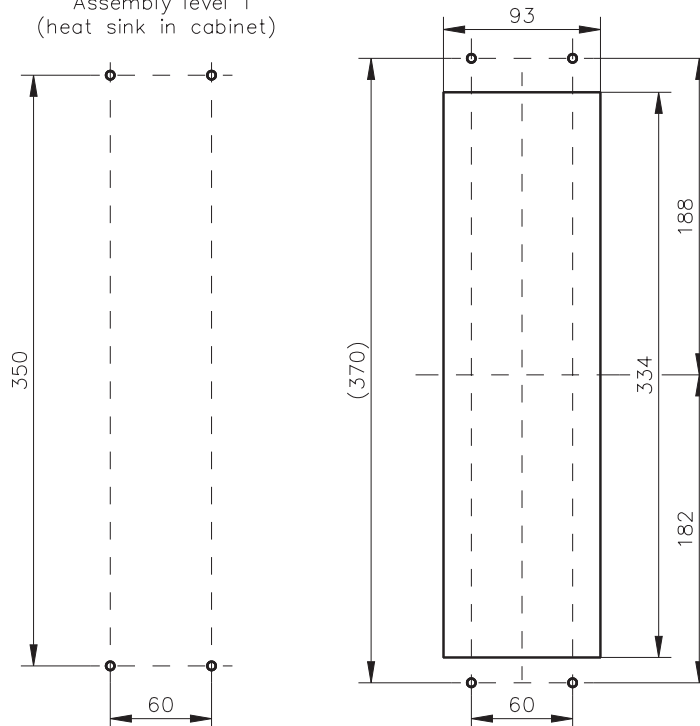

Drill holes for M5 bolts

V.6 Assembly levels and dimensions for digifas™ 7133...7150

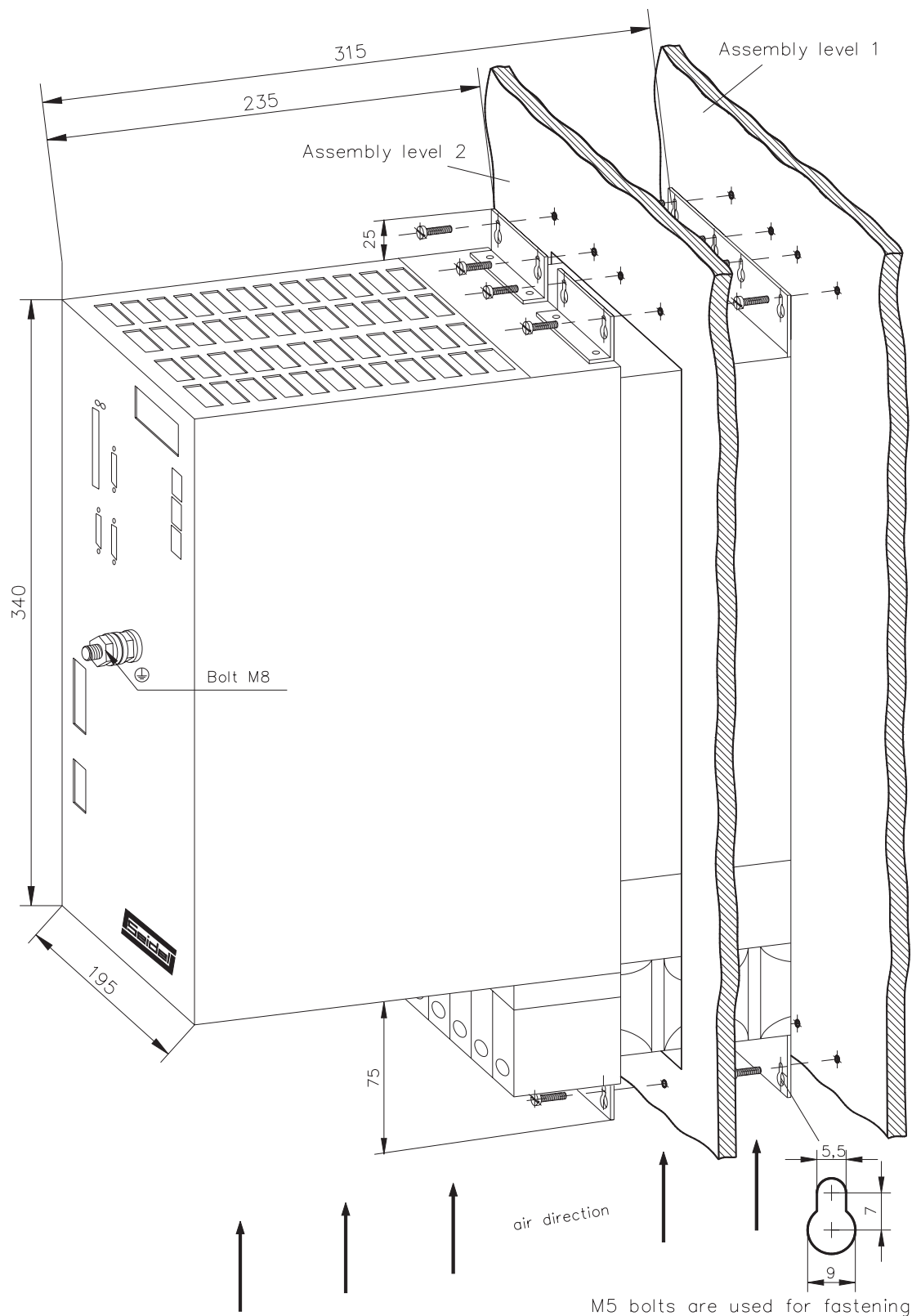

V.7 Installation of digifas™ 7133...7150 in a switchgear cabinet

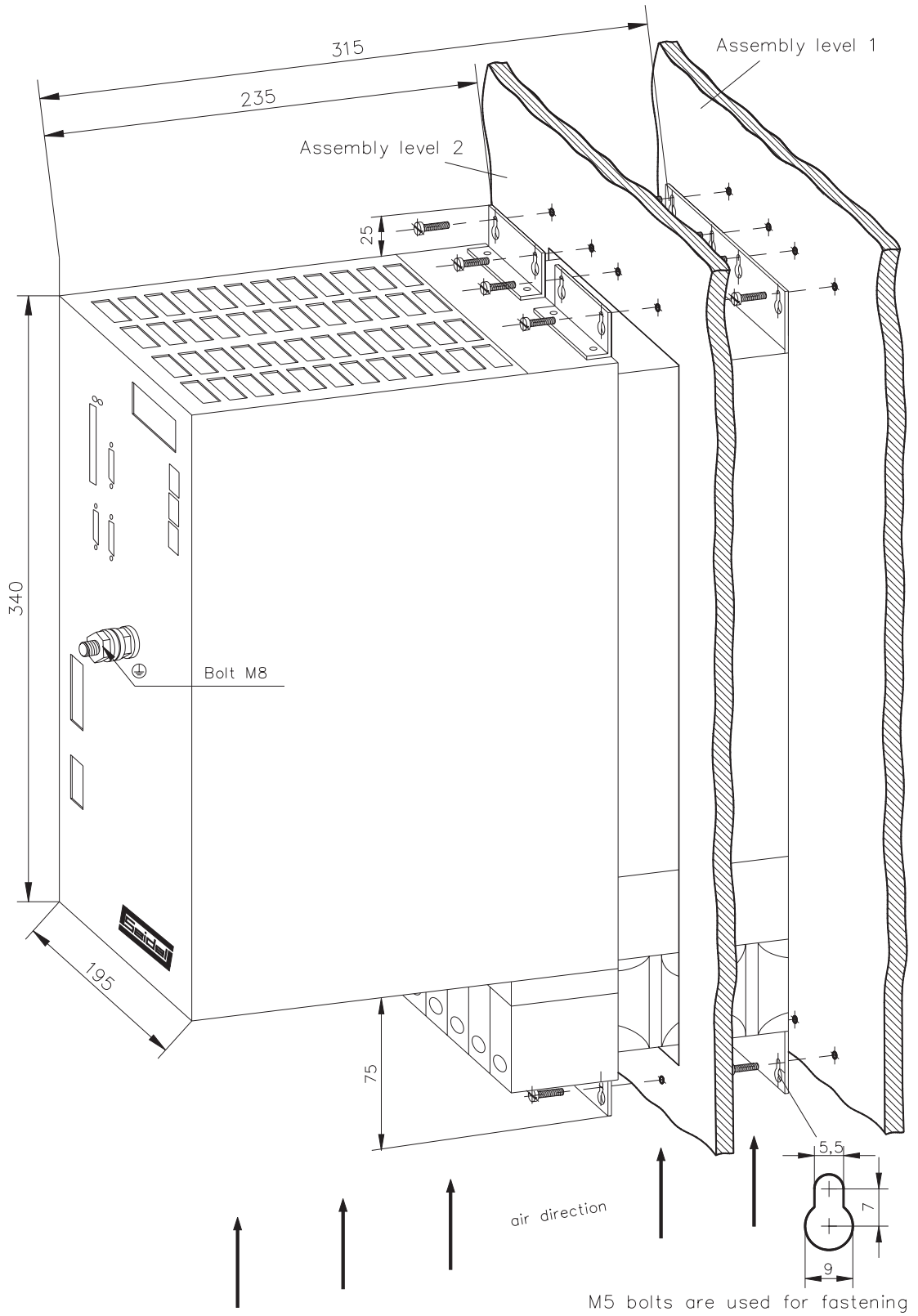

V.8 Mains filters 1EF06 and 3EFxx series

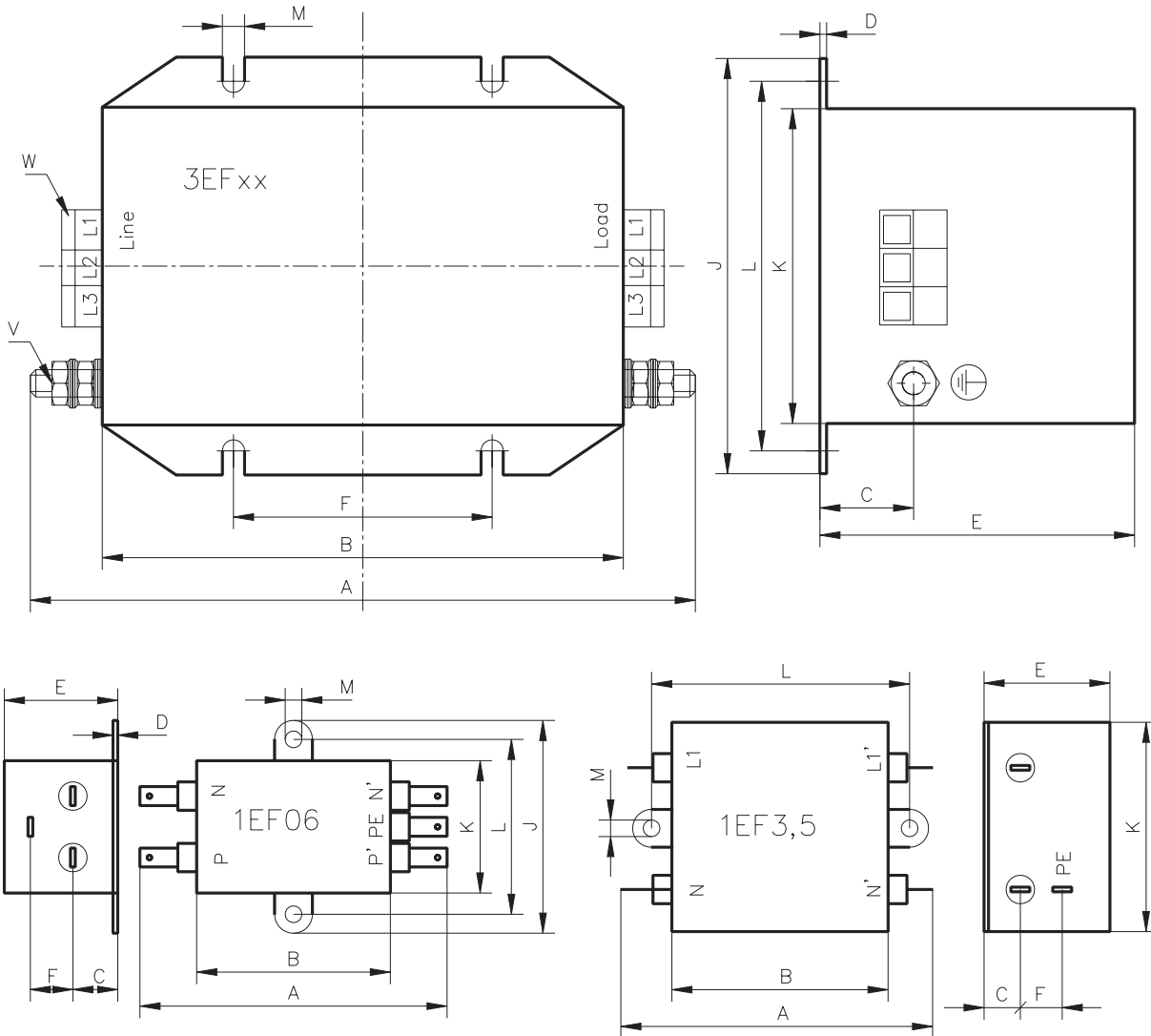

	1EF06	1EF3,5	3EF05	3EF08	3EF16	3EF50*	3EF80*	
Rated voltage	24V DC	230V AC	400V AC					
Rated current	6 A	3,5 A	5 A	8 A	16 A	50 A	80 A	
A	/mm	65,5	98	190	220	240	250	
B	/mm	41	75,9	150	180	200	200	
C	/mm	9,6	12	17	17	17	17	
D	/mm	0,5	–	0,75	0,75	0,75	0,75	
E	/mm	24,1	38,1	50	60	65	65	
F	/mm	9,1	15,5	85	115	115	115	
J	/mm	45	–	105	115	150	150	
K	/mm	28	55,6	75	85	119,5	120	
L	/mm	37	87	90	100	135	135	
M	/mm	3,5	5,3	6,5	6,5	6,5	6,5	
V			M6	M6	M6	M6	M10	
W	/mm ²	Faston	Faston	4	4	4	10	
Weight	/kg	0,065	0,3	1,1	1,8	1,8	3,1	

* digifas® 7100 only

V.9 Mains choke 3L0,5-60

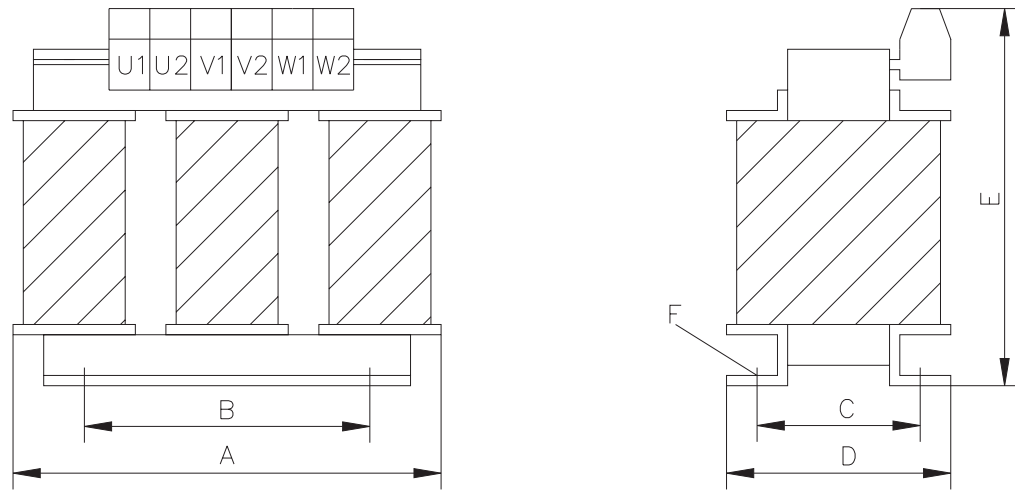

Type		Dimensions in mm						Weight
	Phase	A	B	C	D	E	F	kp
3L-0,5-60	3	155	130	72	110	215	∅8	7,2

V.10 Ballast resistor BAR860

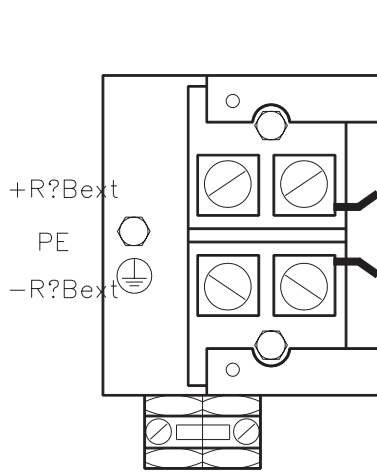
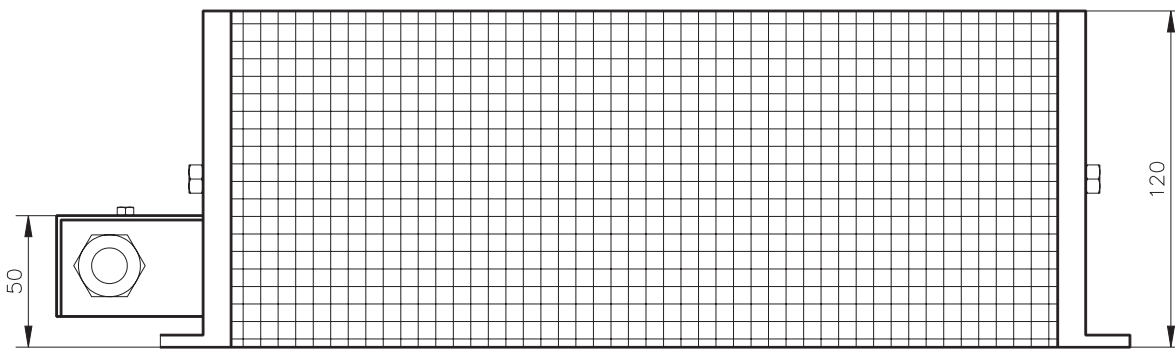
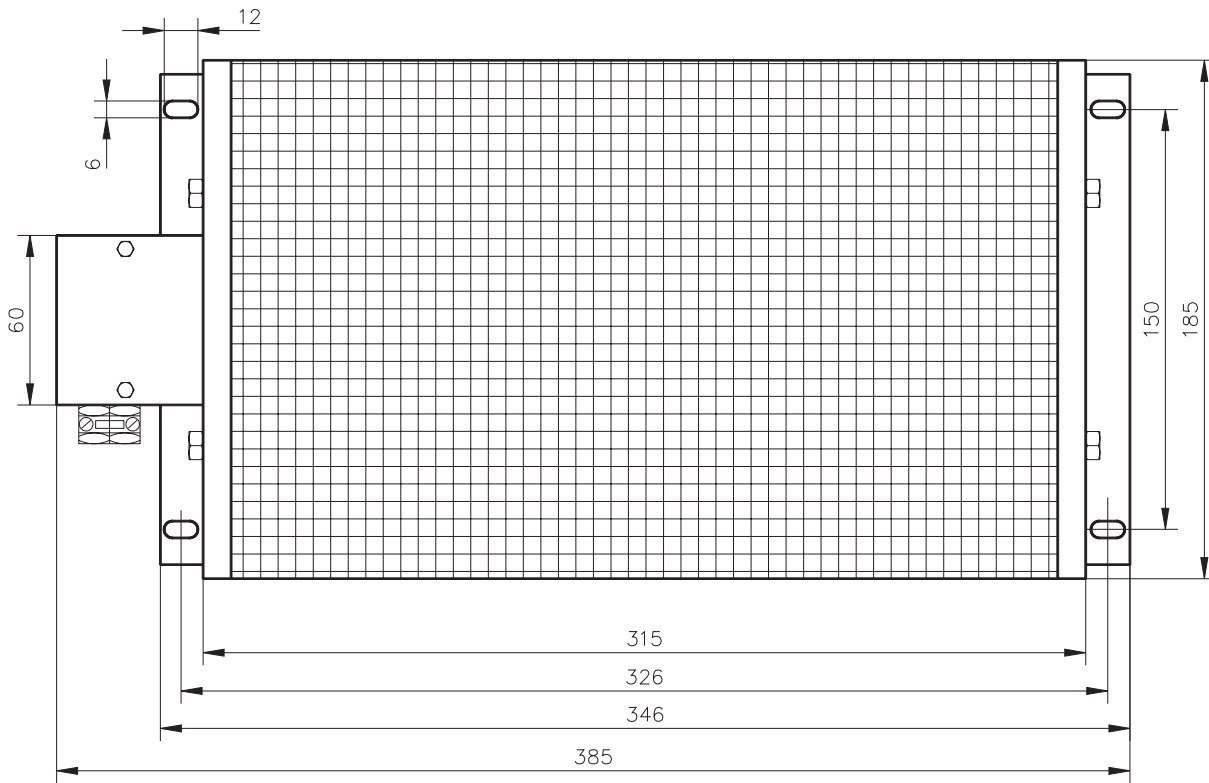

V.11 External 5V DC power supply for the position output

5V DC / 0.25A

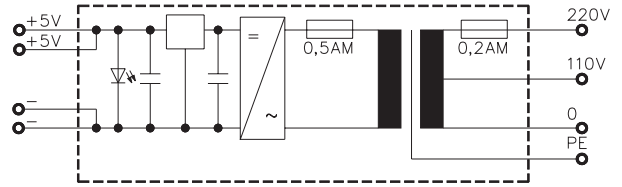
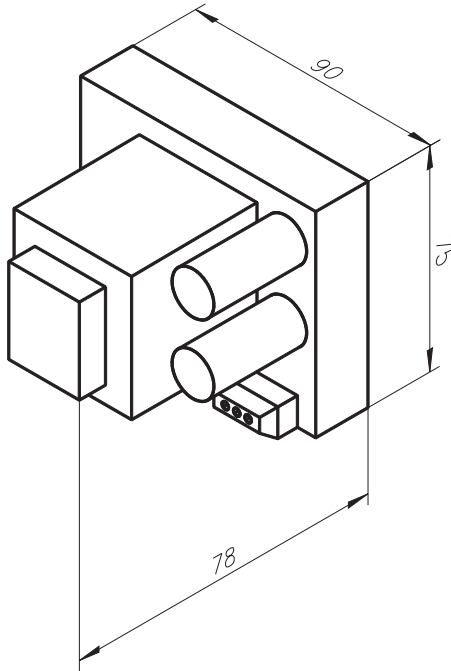

Specifications

Input voltage	110/220V +10% -15%
Input current	0.12/0.06 A
Frequency	50/60 Hz
Primary fuse	0.2 AM (5x20mm)
Output voltage	5 V DC ±2%
Max. output current	250 mA
Eff.residual ripple	< 0.2%
Output fuse	0.5 AM (5x20mm)
Test voltage	according to VDE 0550
Temperature range	-20...+60°C
Type of mounting	DIN rail to EN50022 suspended vertically
Weight	0.5 kg
Order no.	83050

5V DC / 2A

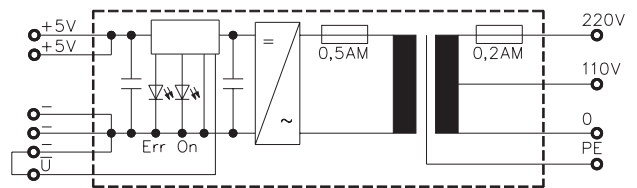
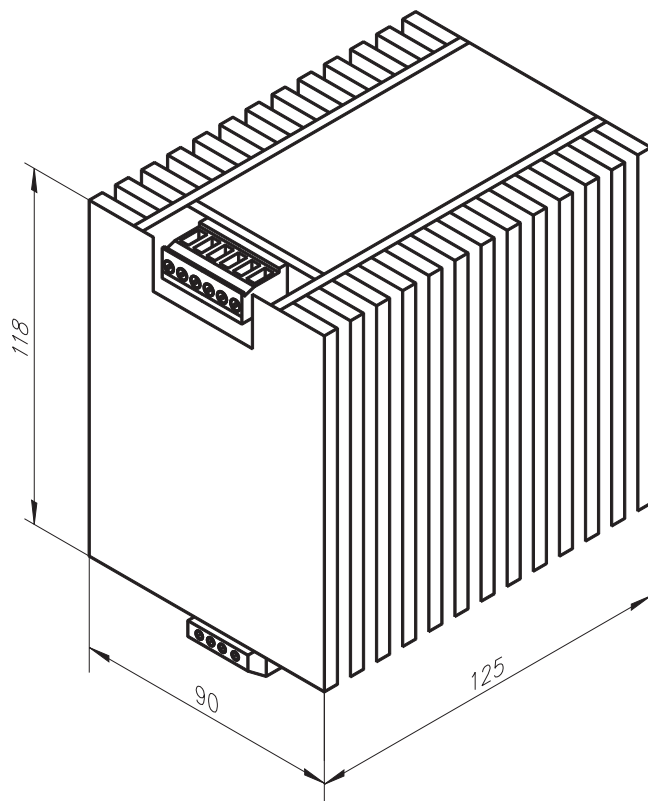

Specifications

Input voltage	110/220V +10% -15%
Input current	1.1/0.6 A
Frequency	50/60 Hz
Primary fuse	1 AT (5x20mm)
Output voltage	5 V DC ±2%
Max. output current	2 A
Eff.residual ripple	< 0.1%
Output fuse	4 AM (5x20mm)
Test voltage	according to VDE 0550
Temperature range	-20...+60°C
Type of mounting	DIN rail to EN50022 suspended vertically
Weight	2.5 kg
Order no.	83033

V.12 External 24V DC power supply for a single servo-amplifier

24V DC / 5A

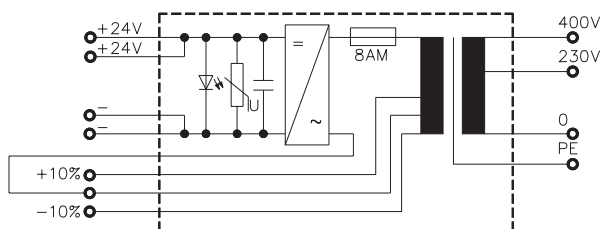
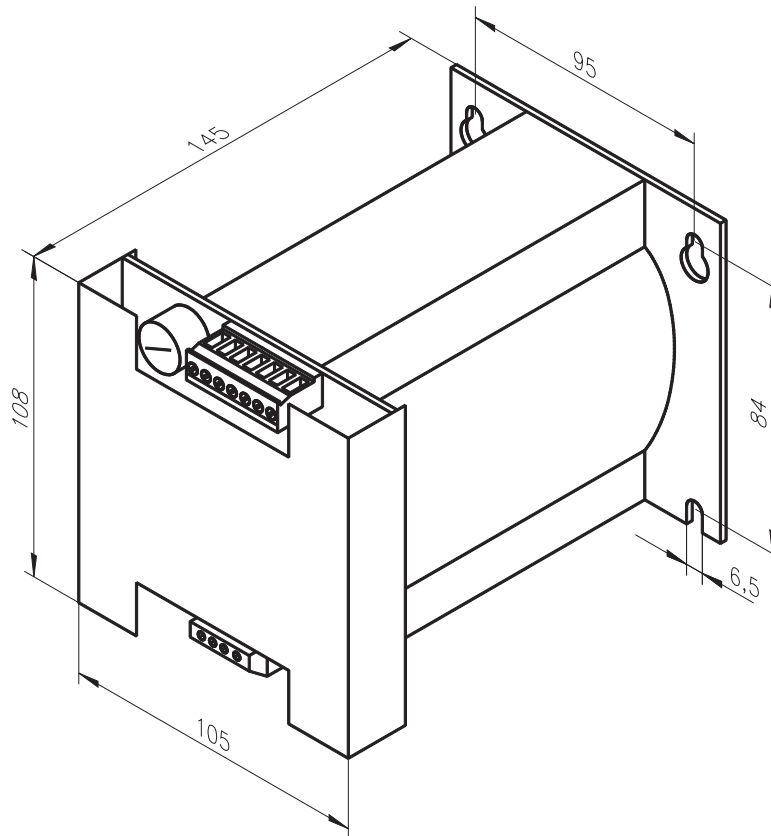

Specifications

Input voltage	230/400V according to DIN IEC 38A (±5%)
Input current	0.8/0.45 A
Frequency	50/60 Hz
Output voltage	24V DC. ±10% secondary reconnectable
Max. output current	5 A
Eff.residual ripple	< 5%
Output fuse	8 AM (5x20mm)
Test voltage	according to VDE 0551
Temperature range	-20...+60°C
Type of mounting	Keyhole suspension, screwable suspended vertically
Weight	4 kg
Order no.	83034

V.13 External 24V DC power supply for up to 7 servo-amplifiers

24V DC / 20A

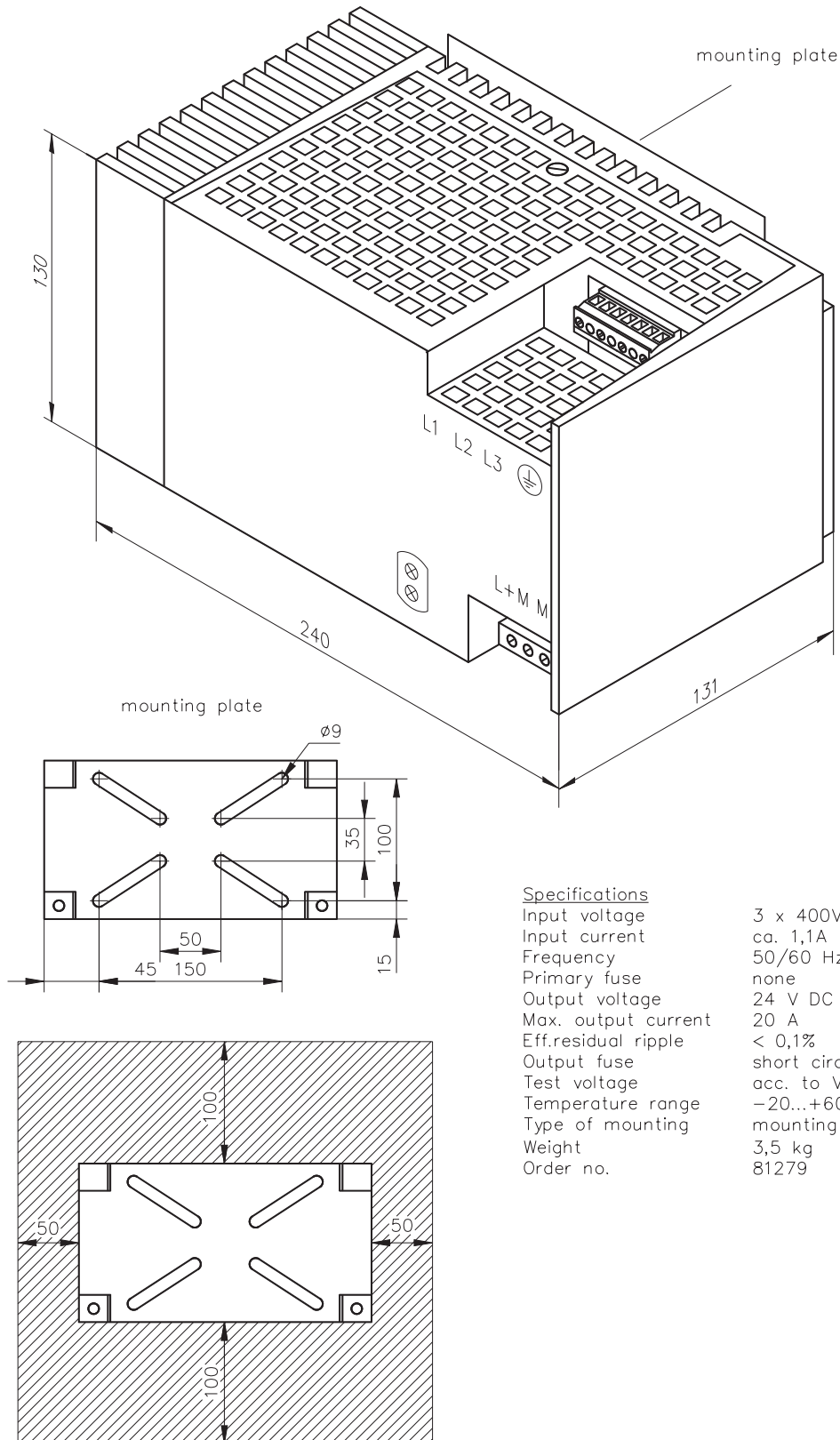

Specifications

Input voltage	3 x 400V AC ±10%
Input current	ca. 1,1A
Frequency	50/60 Hz
Primary fuse	none
Output voltage	24 V DC ±1%
Max. output current	20 A
Eff.residual ripple	< 0,1%
Output fuse	short circuit proof
Test voltage	acc. to VDE 0550
Temperature range	-20...+60°C
Type of mounting	mounting plate
Weight	3,5 kg
Order no.	81279

This page has been deliberately left blank.

VI Appendix

VI.1 Delivery package, transport, storage, maintenance, disposal

- Delivery package :**
- 1 digifas™ 7100 series servo amplifier
 - 3.5" diskette with the operator software BS7200
 - 2 ring cores
 - installation/commissioning manual for digifas™ 7100
 - BS7200 operating manual
 - installation/commissioning manual for the CONNECT module, if one is built in
- Transport :**
- only by qualified personnel
 - only in the original recyclable manufacturer's packaging
 - avoid shocks
 - the servo amplifiers contain electrostatically-sensitive components, which can be damaged by incorrect handling.
Discharge yourself before you touch the servo-amplifier.
Avoid touching highly insulating materials (artificial fabrics, plastic wrappings etc.). Place the servo amplifier on a conductive base.
 - if the packaging is damaged, check the unit for visible damage. In such a case inform the shipper and the manufacturer.
- Storage :**
- only in the original recyclable manufacturer's packaging
 - the servo amplifiers contain electrostatically-sensitive components, which can be damaged by incorrect handling.
Discharge yourself before you touch the servo-amplifier.
Avoid touching highly insulating materials (artificial fabrics, plastic wrappings etc.). Place the servo amplifier on a conductive base.
 - max. stacking height digifas™ 7103...7116 : 10 cartons
digifas™ 7133...7150 : 5 cartons
 - storage temperature -25 ... +85°C, max. 20°/hr variation
 - humidity relative humidity max. 95% no condensation
 - storage duration < 1 year without restriction
> 1 year : the capacitors must be re-formed before commissioning the servo amplifier.
To do this: remove all electrical connections, feed the servo amplifier for about 30 min from single-phase 230V AC on terminals L1 / L2.
- Maintenance :**
- no maintenance required
 - opening the equipment housing invalidates the guarantee
- Cleaning :**
- if the housing is dirty : clean with isopropanol or similar
do not immerse or spray
 - if there is dirt inside the unit : to be cleaned by the manufacturer
 - if the fan screen is dirty : clean with a dry brush
- Disposal :**
- the servo amplifier may be reduced to its principal components by undoing all screw connections (aluminium heat sink and front panel, steel housing sections, electronics boards)
 - the disposal should be performed by a certified disposal company.
We can give you suitable addresses.

VI.2 C€ - relevant system components of digifas™ 7103 to 7116

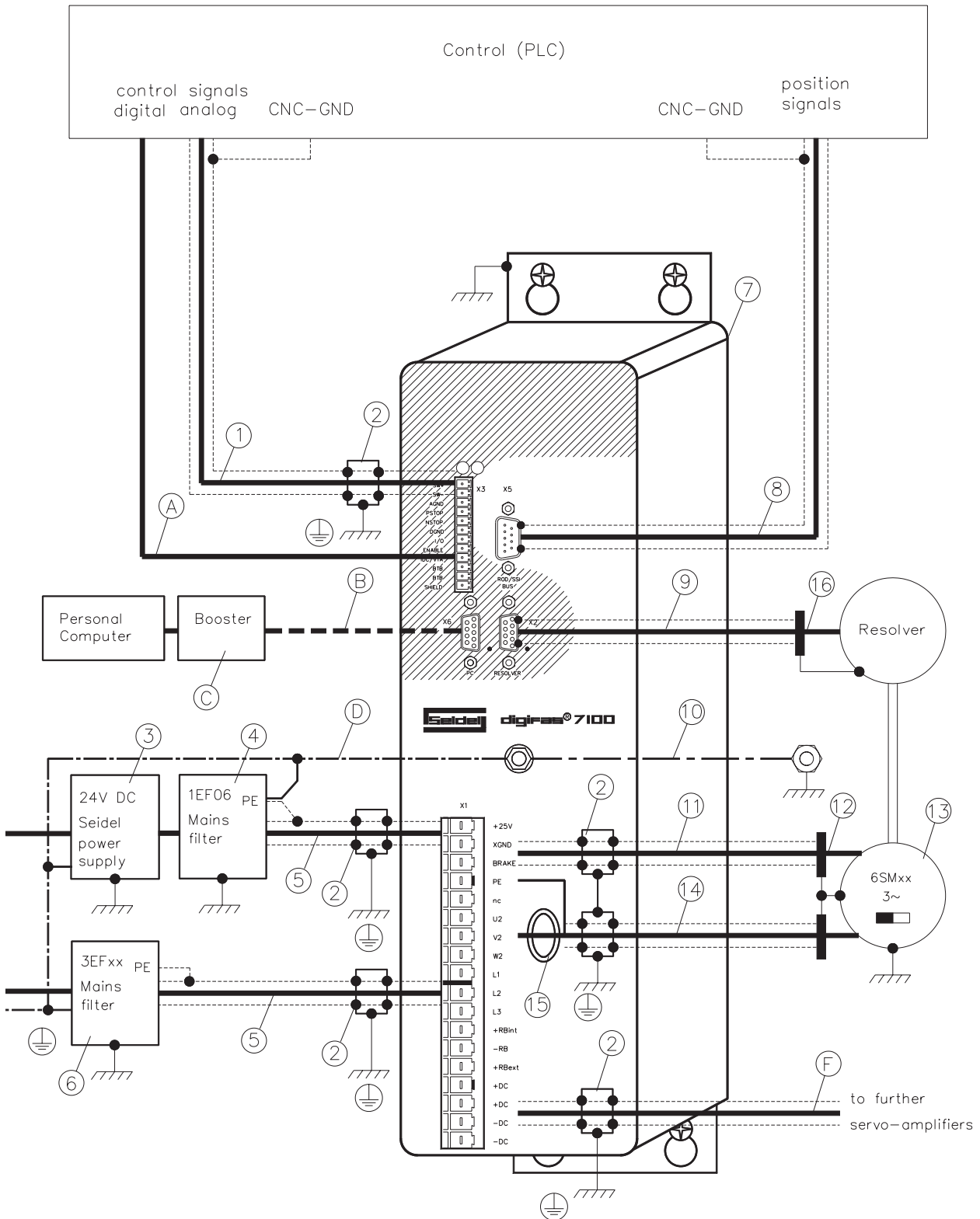



Only under the condition that the system components listed below are used and that the commissioning instructions in this documentation (Chapter II.2) are followed, can we guarantee the conformance of the servo amplifier with the following standards for industrial areas:

- EC EMC Directive 89/336/EEC
- EC Low Voltage Directive 73/231/EEC

If there is any deviation from these requirements you must provide your own measurements to demonstrate conformance to the standards.

The item nos. below refer to the system diagram on the opposite page.

Item no.	Designation	Description
1	analog cable	shielded, twisted pairs, 3x2x0.25mm ²
2	shield terminal clamps	various sizes, manuf. Weidmüller, type KLBÜ
3	mains adapter 24VDC/xA	auxiliary voltage supply
4	1EF06	mains filter, manuf. Seidel, single-phase
5	mains cable	shielded, 4x1.5 ... 4mm ²
6	3EFxx	mains filter, manuf. Seidel, for various currents
7	digifas™ 7103 to 7116	servo amplifier, manuf. Seidel, various versions
8	ROD/SSI cable	shielded, twisted pairs, 4x2x0.25mm ²
9	resolver cable	manuf. Seidel, ready-made, can be trailed
10	woven tape	manuf. Seidel, ready-made
11	brake cable	shielded, can be trailed, 4x1.5mm ²
12	EMC-PGxx	PG screwed gland, built into the motor terminal box
13	6SMxx	synchronous servo-motor, various frame sizes
14	motor cable	manuf. Seidel, can be trailed, shielded, integral brake cable available for size with cross-section 1.5mm ²
15	ring core	ferrite ring, various sizes
16	EMC-RES-connector	component of resolver cable manuf. by Seidel

Make a selection from our price list. Configure your own tailor-made € servo system from our individual components.

Our applications department is always available to deal with your queries.

The components listed below do not have any decisive effect on the conformance of single-axis systems to the standards. However, for multi-axis systems item F may need to be shielded, depending on the length.

- A — 11 x 0.5mm², single cores
- B — PC cable, manuf. Seidel
- C — line driver (booster)
- D — earth lead, 1.5 ... 16mm²
- F — length more than 20cm : shielded cable, 7x1.5 ... 4mm²
length up to 20cm : 5 single cores, 1.5 ... 4mm²

VI.3 C€ - relevant system components of digifas™ 7133 to 7150

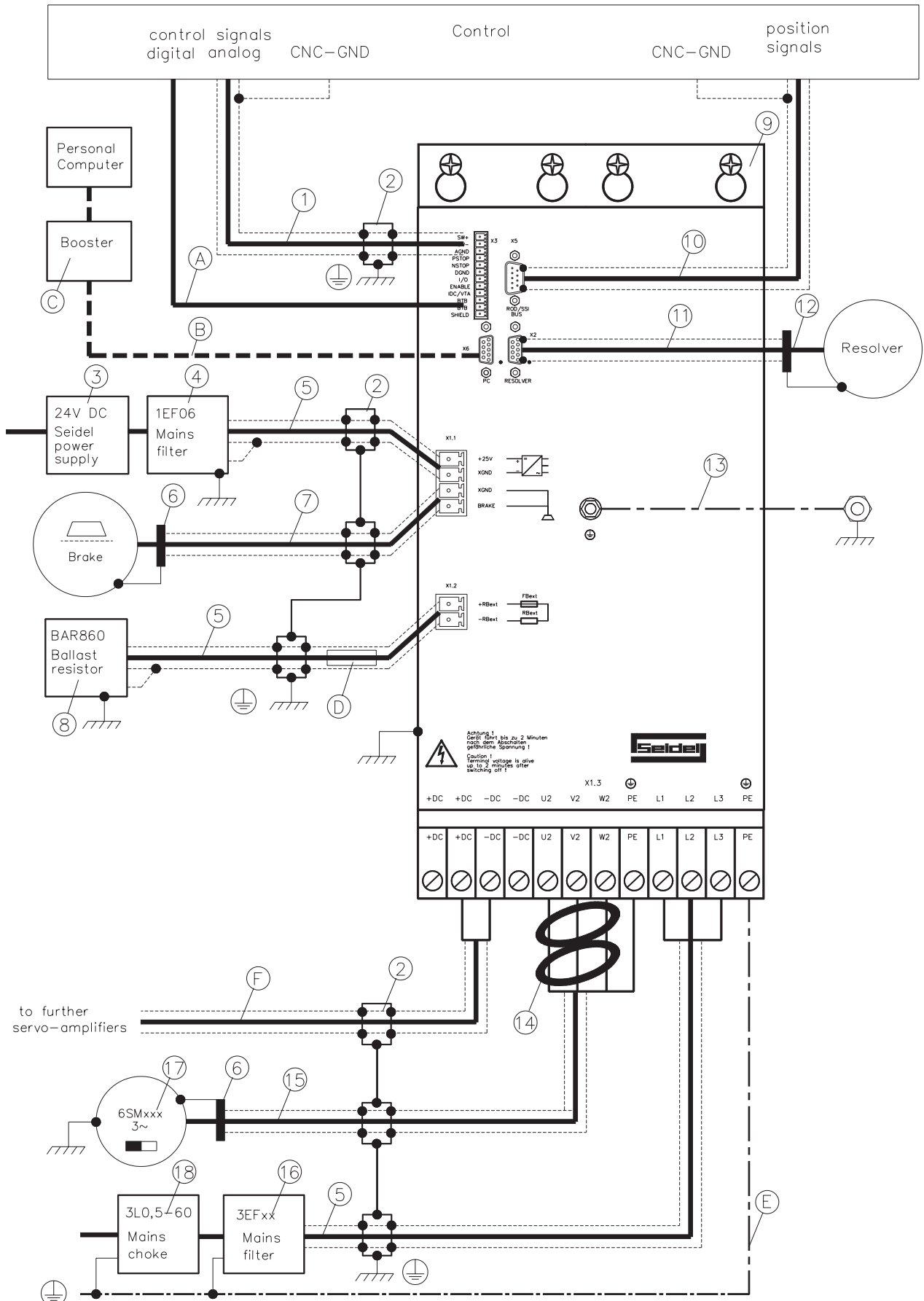



Only under the condition that the system components listed below are used and that the commissioning instructions in this documentation (Chapter II.2) are followed, can we guarantee the conformance of the servo amplifier with the following standards for industrial areas:

- EC EMC Directive 89/336/EEC
- EC Low Voltage Directive 73/231/EEC

If there is any deviation from these requirements you must provide your own measurements to demonstrate conformance to the standards.

The item nos. below refer to the system diagram on the opposite page.

Item no.	Designation	Description
1	analog cable	shielded, twisted pairs, 3x2x0.25mm ²
2	shield terminal clamps	various sizes
3	mains adapter 24VDC/xA	auxiliary voltage supply
4	1EF06	mains filter, manuf. Seidel, single-phase
5	mains cable	shielded, 4x1,5 ... 25mm ²
6	EMC-PGxx	PG screwed gland, built into the motor terminal box
7	brake cable	shielded, can be trailed, 4x1,5mm ²
8	BAR860	Ballast resistor, manuf. Seidel
9	digifas™ 7133 to 7150	servo amplifier, manuf. Seidel, various versions
10	ROD/SSI cable	shielded, twisted pairs, 4x2x0.25mm ²
11	resolver cable	manuf. Seidel, ready-made, can be trailed
12	EMC-RES-connector	component of resolver cable manuf. by Seidel
13	woven tape	manuf. Seidel, ready-made
14	ring core	ferrite ring, various sizes
15	motor cable	manuf. Seidel, can be trailed, shielded
16	3EFxx	mains filter, manuf. Seidel, for various currents
17	6SMxx	synchronous servo-motor, various frame sizes
18	3L0,5-60	mains choke

Make a selection from our price list. Configure your own tailor-made €€ servo system from our individual components.

Our applications department is always available to deal with your queries.

The components listed below do not have any decisive effect on the conformance of single-axis systems to the standards. However, for multi-axis systems item F may need to be shielded, depending on the length.

A	—	11 x 0.5mm ² , single cores
B	—	PC cable, manuf. Seidel
C	—	line driver (booster)
D	—	Fuses FBext1 and FBext2
E	—	earth lead, 1.5 ... 16mm ²
F	—	length more than 20cm : shielded cable, 7x10 ... 25mm ² length up to 20cm : 5 single cores, 10 ... 25mm ²

VI.4 Fault-finding

The table below should be seen as a “First-Aid” box. There may be a wide variety of possible reasons for the occurrence of a fault, depending on the circumstances in your system.

Multi-axis systems may conceal further causes of a fault.

Our applications department can give you further assistance with problems.

Fault	possible causes	ways to remove the cause of the fault
fault signal: comms. fault	<ul style="list-style-type: none"> — wrong cable used — cable inserted into wrong position in the PC or the servo amplifier — wrong PC interface selected — PC driver power insufficient — booster defect — booster mains adapter defect — mains voltage for booster mains adapter not correct — PC is not grounded 	<ul style="list-style-type: none"> — use the Seidel PC cable — insert the connector into the correct position in the PC or the servo amplifier — correct call in the op. software — use a booster — replace booster — replace mains adapter — check mains supply — ground the PC
fault signal: undervoltage	<ul style="list-style-type: none"> — mains voltage not present or too low when the servo amplifier is enabled 	<ul style="list-style-type: none"> — enable the servo amplifier only when the mains supply has been switched on
fault signal: overvoltage	<ul style="list-style-type: none"> — ballast power inadequate, ballast power limit was reached and the ballast resistor was switched out. This caused the excessive intermediate circuit voltage. — mains voltage too high — short-circuit / earth short in the external ballast resistor circuit 	<ul style="list-style-type: none"> — shorten the RAMP- braking time, use an external ballast resistor with higher power rating and adjust the ballast power to suit — use a mains transformer — remove short-circuit / earth short
fault signal: mains BTB	<ul style="list-style-type: none"> — controller enable present, although mains voltage not available — at least 2 mains phases missing — inrush-current limiting of the servo amplifier is defective 	<ul style="list-style-type: none"> — enable the servo amplifier only when the mains supply has been switched on — check mains supply — return servo amplifier to manufacturer for repair
fault signal: brake	<ul style="list-style-type: none"> — short-circuit in the supply leads to the motor-holding brake — defective motor-holding brake 	<ul style="list-style-type: none"> — remove short-circuit — replace motor
fault signal: output stage fault	<ul style="list-style-type: none"> — motor cable has short-circuit/ earth short — motor has short-circuit / earth short — output stage overheated — defect in output stage — short-circuit / earth short in the external ballast resistor circuit 	<ul style="list-style-type: none"> — replace cable — replace motor — improve ventilation — return servo amplifier to manufacturer for repair — remove short-circuit / earth short
Fault signal: V-fault (aux. voltage)	<ul style="list-style-type: none"> — the aux. voltage produced in the servo amplifier is defective 	<ul style="list-style-type: none"> — return servo amplifier to manufacturer for repair

Fault	possible causes	ways to remove the cause of the fault
fault signal: resolver	<ul style="list-style-type: none"> — resolver plug not properly connected — break in resolver cable, cable crushed etc. — wrong type of resolver 	<ul style="list-style-type: none"> — check connector — check cable — use two-pole resolver
fault signal: heat sink temperature	<ul style="list-style-type: none"> — permissible heat sink temperature exceeded 	<ul style="list-style-type: none"> — improve ventilation
fault signal: internal temperature	<ul style="list-style-type: none"> — permissible internal temperature exceeded 	<ul style="list-style-type: none"> — improve ventilation
fault signal: motor temperature	<ul style="list-style-type: none"> — thermal cut-out in motor has been activated — resolver connector loose or break in resolver cable 	<ul style="list-style-type: none"> — wait until the motor has cooled down, then investigate the cause of the overheating — use new resolver cable
no motor rotation	<ul style="list-style-type: none"> — servo amplifier not enabled — break in setpoint lead — motor phases swapped — brake not released — drive mechanically jammed — no. of motor poles set incorrectly — wrong type of resolver 	<ul style="list-style-type: none"> — apply ENABLE signal — check setpoint lead — correct motor phasing — check braking control — check mechanism — set parameter: motor pole no. — use two-pole resolver
motor runaway	<ul style="list-style-type: none"> — motor phases swapped — with -IL- option: ROD cable defect or not properly connected 	<ul style="list-style-type: none"> — correct motor phasing — check ROD/SSI cable
motor oscillates	<ul style="list-style-type: none"> — gain too high — shielding in resolver cable broken — AGND not wired up 	<ul style="list-style-type: none"> — reduce Kp parameter — replace resolver cable — join AGND to CNC-GND

VI.5 Glossary

B	Ballast circuit	converts excess regenerative energy from the motor during braking into heat in the ballast resistor
C	Clock	clock signal
	Common-mode voltage	amplitude of the disturbance which can be eliminated in an analog input (differential input)
	CONNECT module	module built into the servo amplifier, with integral positional control, which provides special interface variations for the connection to the higher-level control
	Counts	internal count pulses, 1 pulse = 1/4096 of 1 turn
	Continuous ballast power	average power which can be dissipated by the ballast circuit
	Current controller	regulates the difference between the current setpoint and the actual current value to 0. output : power output voltage
D	Disable	removal of the ENABLE signal (0V or open)
E	Earth short	electrically conductive connection between a phase and PE
	Enable	enable signal for the servo amplifier (+24V)
F	Field-bus interface	here: CONNECT module CAN-CONNECT and PROFIBUS-CONNECT
	Final limit speed	max. value of normalized speed at $\pm 10V$
G	GRAY code	special form of binary encoding
H	Holding brake	a brake in the motor which must only be activated at standstill
I	Input drift	temperature and age-dependent changes in an analog input
	I^2t threshold	monitoring of the actual effective current demand I_{rms}
	Incremental encoder interface	position signal by 2 signal with 90° phase difference, not an absolute position signal
	I_{peak} , peak current	effective value of the pulse current
	I_{rms} , effective current	effective value of the continuous current
	Intermediate circuit	rectified and smoothed power DC voltage
K	K_p , P-gain	proportional gain of a control loop
L	LC display	liquid-crystal display
	Limit switch	limit switch for the traverse path of the machine; implemented as break contact
M	Machine	the sum of all components which are connected together and of which at least one is movable
	Mains filter	external device to divert disturbances on the power leads to PE
	Monitor output	output of an analog measurement value
	Motion block	data packet with all the positional control parameters which are required to perform a movement – only when a CONNECT module is available
	Multi-axis system	machine with several independent drive axes

N	Natural convection	free air movement for cooling
	NI pulse	is produced once per turn by incremental encoders, used to establish the zero point for the machine
O	Optocoupler	optical connection between two electrically independent systems
P	P-controller	control loop with purely proportional characteristic
	Phase shift	compensation for the phase lag between the electro-magnetic and magnetic fields in the motor
	PID controller	a control loop with proportional, integral and differential characteristics
	PID-T2	filter time constant for the speed control
	Position controller	regulates the difference between the position setpoint and the actual positional value to 0. output : speed setpoint
	Potential isolation	electrically decoupled
R	Power contactor	system protection with phase-failure monitoring
	Pulse power of the ballast circuit	maximum power which can be dissipated in the ballast circuit
	Reset	new start of the microprocessor
	Resolver-digital converter	conversion of the analog resolver signals into digital information
	Reversing mode	operation with a periodic change of direction
S	Ring core	ferrite ring(s) for interference suppression
	Servo amplifier	device for the control of speed and torque of a servo motor
	Short-circuit	here: electrically conductive connection between two phases
	Speed controller	regulates the difference between the speed setpoint SW and the actual speed to 0. output: current setpoint
	SSI-interface	cyclically absolute, serial positional information
T	SW ramp	limitation of the rate of change of the speed setpoint SW
	T-tacho, tachometer time constant	filter time constant in the speed feedback of the control loop
	Tachometer voltage	a voltage which is proportional to the speed
	Thermal cut-out contact	a temperature sensitive switch which is built into the motor winding
	Tn, I-time constant	integral component of the control loop
Z	Tv, D-time constant	differential component of the control loop
	Zero pulse	is produced once per turn by incremental encoders, used to establish the zero point for the machine

VI.6 Parameter list

Group	Display text	Remarks	Units	min.	max.	Default	actual value
Current	I _{rms}	effective current	A	0.1	I _{nom}	0.5I_{nom}	
controller	I _{peak}	peak current	A	0.2xI _{nom}	2xI _{nom}	I_{nom}	
	I ² t threshold	monitoring threshold	%	0	100	80	
	Kp	P(roportional) gain	-	0.1	8	1,5	
	Tn	I(integr.) time constant	ms	0.1	10	0,6	
Speed	Kp	P-gain	-	1	63	10 (25)	
controller	Tn	I(ntegr.) time constant	ms	0.1	1000	10 (12)	
	PID-T2	2. time constant	ms	0.2	25	2.0	
	SW offset	compensation	mV	-120	+120	0	
	SW ramp +	ramp up	ms	2	6300	10	
	SW ramp -	ramp down	ms	2	6300	10	
	Final limit speed	final tacho speed	min ⁻¹	800	8000	3000	
	DC monitor	select IDC/VTA	-	TACHO/ CURRENT	S_fehl/ I-soll	TACHO	
	Limit switch	on/off/stop	-	off/on	stop	off	
	Start Phi	phase lead	min ⁻¹	0	0,8 x final speed	1500	
	Limit Phi	phase lead	°electr.	0	45	20	
	T-tacho	tacho time constant	ms	0.2	100	0.6	
General	Motor pole no.	steps ±2	-	2	12	6	
	Language	operating language	-	German	Engl./French	German	
	Resolv. pole no.	steps 2/4/6	-	2	6	2	
	I/O	programmable input/output	-	various	various	RESET	
	Ballast resistor	select resistor	-	internal	external	internal (external)	
	Ballast power	ext. ballast power	W	1	2000 (4000)	200 (860)	
	Brake	holding brake active	-	without	with	without	
	NI offset	ROD zero-pulse pos.	increment	0	resolution	0	
	ROD/SSI	position output	-	ROD/SSI	off	ROD	
	ROD code	ROD output format	-	binary	decimal	bin	
	Resolution	ROD resolution	incr./turn	512/1024	500/1000	1024	
	SSI code	SSI output format	-	binary	Gray	bin	
	SSI clock	SSI clock rate	kHz	200/200	1500/1500	200	

Values in brackets for digifas™ 7133...7150

Customer Cabinet no. Unit no.

Place, date Signature

VI.7 Index

<u>Text</u>	<u>Page</u>	<u>Text</u>	<u>Page</u>
A AGND	I-2, I-10, II-5, II-7	N NI	I-2
Ambient temperature	I-9, II-18	NI-Offset	II-16
Analog input and output circuits	V-2	NSTOP	I-2, II-5, II-7, III-1
Assembly	II-3, V-4, V-5, V-6, V-7	NSTOP input	II-5, II-7, III-1
B Ballast circuit	I-10	O Operating time	II-18
Ballast power	I-10, II-16, II-18	Option -DISP-	IV-4
Ballast resistor	I-10, II-16, V-10	Option -IL-	IV-6
BIT CONNECT	I-3	P Parameter	II-16
Brake	II-5, II-7, II-16, III-3	PGND	I-2, I-10, II-5, II-7
BTB	I-2, II-5, II-7, II-18, III-2	PID-T2	II-17
C CAN CONNECT	I-3	Pin assignment	II-9, II-10
CE relevant components 7103-16	VI-2	Pollution level	I-9
CE relevant components 7133-50	VI-4	Prescribed usage	I-1
Commissioning	II-14	PROFIBUS CONNECT	I-3
Connection methods	II-11	Protection class	I-9
Constant current	II-18	PSTOP	I-2, II-5, II-7, III-1
Constant speed	II-18	PSTOP input	II-5, II-7, III-1
Current: actual value	II-18	PULSE CONNECT	I-3
D DC Monitor	II-5, II-7, II-17, III-2	R RBext	I-2
Delivery package	VI-1	RBint	I-2
DGND	I-2, I-10, II-5, II-7	Re-formation	II-14, VI-1
digifas™ -71xx	I-3	Resolution	II-16
digifas™ -71xx-CAN	I-3, I-8	Resolver	II-5, II-7
digifas™ -71xx-L2/DP	I-3, I-8	Resolver pole no.	II-16
digifas™ -71xx-SPS	I-3, I-8	Reversing mode	II-15, II-18
digifas™ -71xx-STEP	I-3, I-8	ROD Code	II-16
Digital input and output circuits	V-3	ROD Interface	II-5, II-7, IV-1
Disposal	VI-1	ROD/SSI	II-16
E EMC wiring diagram	II-4	Rotation angle	II-18
EMV	I-2, II-1, II-4	S Safety instructions	1-C
Enable input	II-5, II-7, III-1	Setpoint	I-8, II-5, II-7, III-1
F Fault messages	II-18	Setpoint Offset	II-17
Fuse protection	I-9, II-5, II-7	Setpoint ramp -	II-17
G GND	I-10	Setpoint ramp +	II-17
Ground symbol	II-2	Shielding	II-3, II-4, II-5, II-7
Grounding	II-3, II-4, II-5, II-7	Speed	II-18
H Heat sink temperature	II-18	Speed limit	II-17
Humidity	I-9, VI-1	SSI clock	II-16
I I/O	II-5, II-7, II-16, III-1, III-2	SSI Code	II-16
I/O input	II-5, II-7, III-1	SSI Interface	IV-2
I/O output	II-5, II-7, III-2	Stacking height	VI-1
I2t	II-18	Standard version	I-3
I2t threshold	II-17	Start Phi	II-17
IDC	I-2, II-5, II-7, II-17, III-2	Storage	VI-1
IDC output	II-5, II-7, III-2	Storage duration	VI-1
Installation	II-2	Storage temperature	VI-1
Installation altitude	I-9	Supply voltage	I-9
Intermediate circuit	I-8, I-10, II-18	SW	I-2, III-1
Ipeak	II-17	SW input	II-5, II-7, III-1
Irms	II-17	System grounds	I-10
K Key control	IV-4, IV-5	T T tachometer	II-17
Kp current	II-17	Technical Data	I-8
Kp speed	II-17	Tn current	II-17
L Language	II-16	Tn speed	II-17
LC display	IV-4	Transport	VI-1
Lead cross-sections	I-9	V Ventilation	I-9, II-3
LED	I-2, I-9	VTA	I-2, II-5, II-7, II-17, III-2
Limit Phi	II-17	VTA output	II-5, II-7, III-2
Limit switches	II-5, II-7, II-17	W Wiring	II-3, II-4, II-5, II-6, II-7, II-8
Location	II-3	Wiring diagram	II-5, II-7
M Mains choke	V-9	X XGND	I-2, I-10, II-5, II-7
Mains filters	V-8		
Maintenance	VI-1		
Motor pole no.	II-16		
Mounting position	I-9		
Multi-axis system	I-9, II-8		

Vertrieb und Service / Sales and Service / Agence et Services

Bundesrepublik Deutschland/ Germany/Allemagne

Seidel Servo Drives GmbH
Verkaufsniederlassung Nord
Dasselsbrucher Str. 49a
D-29227 Celle
Tel.: +49(0)5141 - 98 10 40
Fax: +49(0)5141 - 98 10 41

Seidel Servo Drives GmbH
Verkaufsniederlassung West
Wacholderstr. 40-42
D-40489 Düsseldorf
Tel.: +49(0)203 - 99 79 - 180
Fax: +49(0)203 - 99 79 - 118

Seidel Servo Drives GmbH
Verkaufsniederlassung Süd-West
Bruchsaler Str. 3
D-76646 Bruchsal-Untergrombach
Tel.: +49(0)7257 - 9 23 07
Fax: +49(0)7257 - 9 23 08

Seidel Servo Drives GmbH
Verkaufsniederlassung Süd-Ost
Landsbergerstr. 17
D-86947 Weil
Tel.: +49(0)8195 - 99 92 50
Fax: +49(0)8195 - 99 92 33

Servo-Dyn
Technik GmbH
Münzgasse 10
D-01067 Dresden
Tel.: +49(0)351 - 49 05 793
Fax: +49(0)351 - 49 05 794

Dänemark/ Denmark/Danemark

DIGIMATIC
Ormhøjgaardvej 12-14
DK-8700 Horsens
Tel.: +45 - 76 26 12 00
Fax: +45 - 76 26 12 12

Finnland/ Finland/Finlande

Drivematic OY
Hevosenkentä 4
FIN-28430 Pori
Tel.: +358 - 2 - 61 00 33 11
Fax: +358 - 2 - 61 00 33 50

Frankreich/ France/France

Seidel Servo Drives GmbH
Parc technologique St.Jacques
2 rue Pierre et Marie Curie
F-54320 Maxéville
Tel.: +33(0)3 83 95 44 80
Fax: +33(0)3 83 95 44 81

Großbritannien/ Great Britain/Royaume-Uni

Kollmorgen
PO Box 147, KEIGHLEY
West Yorkshire, BD21 3XE
Tel.: +44(0)15 35 - 60 76 88
Fax: +44(0)15 35 - 68 05 20
Heason Technologies Group
Claremont Lodge
Fontwell Avenue
Eastergate Chichester PO20 6RY
Tel.: +44(0)12 43 - 54 54 00
Fax: +44(0)12 43 - 54 45 90

Italien/ Italy/Italie

M.C.A. s.r.l.
Via f. Turati 1
I-20016 Pero (Mi)
Tel.: +39(0)02 - 33 91 04 50
Fax: +39(0)02 - 33 90 85 8

Niederlande/ Netherlands/Pays-Bas

Dynamic Drives
Jan van der Heydenstraat 24a
NL-2665 JA Bleiswijk
Tel.: +31(0)10 - 52 15 490
Fax: +31(0)10 - 52 18 994

Schweden/ Sweden/Suède

S D T AB
SE-25467 Helsingborg
Tel.: +46(0)42 - 380 800
Fax: +46(0)42 - 380 813
Stockholm
SE-12030 Stockholm
Tel.: +46(0)8 - 640 77 30
Fax: +46(0)8 - 641 09 15
Göteborg
SE-42671 Västra Frölunda
Tel.: +46(0)31 - 69 62 60
Fax: +46(0)31 - 69 62 69

Schweiz/ Switzerland/Suisse

Seidel Servo Drives GmbH
Eggbühlstr. 14
CH-8050 Zürich
Tel.: +41(0)1 - 300 29 65
Fax: +41(0)1 - 300 29 66

Spanien/ Spain/Espagne

Comercial BROTOMATIC, S.L.
San Miguel de Acha, 2 Pab.3
E-01010 Vitoria
Tel.: +34 945 - 24 94 11
Fax: +34 945 - 22 78 32

Systempartner / System partners / Partenaires du syst me

Bundesrepublik Deutschland/ Germany/Allemagne

Werner P. Hermes
Ingenieurbüro
Turmstr. 23
40750 Langenfeld
Tel.: +49(0)212 - 65 10 55
Fax: +49(0)212 - 65 10 57

EAT GmbH
Elektronische Antriebstechnik
Abrichstr. 19
79108 Freiburg
Tel.: +49(0)761 - 13 03 50
Fax: +49(0)761 - 13 03 555

IBK Ingenieurbüro Keßler GmbH
Dachmisser Str. 10
21394 Kirchgellersen
Tel.: +49(0)4135 - 12 88
Fax: +49(0)4135 - 14 33

Großbritannien/ Great Britain/Royaume-Uni

Motor Technology Ltd.
Unit 1
Chadkirk Industrial Estate
Ofterspool Road
Romiley, Stockport
GB-Cheshire SK6 3LE
Tel.: +44(0)161 - 42 73 641
Fax: +44(0)161 - 42 71 306

Schweiz/Switzerland/Suisse

Boby Servo Electronic AG
Zentralstr. 6
CH-6030 Ebikon
Tel.: +41(0)41 - 440 - 77 22
Fax: +41(0)41 - 440 - 69 43

Niederlande/ Netherlands/Pays-Bas

Kiwiet
Ingenieurbüro
Helenaveenseweg 35
NL-5985 NK Panningen (Grashoek)
Tel.: +31(0)77 - 30 76 661
Fax: +31(0)77 - 30 76 646

Italien/Italy/Italie

Servo Tecnica
Viale Lombardia 20
I-20095 Cusano Milanino (MI)
Tel.: +39(0)02 - 66 42 01
Fax: +39(0)02 - 66 40 10 20

Australien/Australia/Australie

FCR Motion Technology PTY. Ltd.
23 Mac Arthurs Road
Altona North, 3025
Melbourne/Australia
Tel.: +61 393 99 15 11
Fax: +61 393 99 14 31

Seidel Servo Drives GmbH

Hausanschrift

Wacholderstr. 40-42
D - 40489 Düsseldorf
Tel.: +49(0)203 - 99 79 - 0
Fax: +49(0)203 - 99 79 - 155
Internet : <http://www.seidelservodrives.de>

Postanschrift

Postfach 34 01 61
D-40440 Düsseldorf

Kollmorgen

201 Rock Road
Radford, VA 24141
Tel.: +1 540 - 639 - 24 95
Fax: +1 540 - 731 - 08 47
Internet : <http://www.kollmorgen.com>