

QRE1113 Package Dimensions^(1, 2)

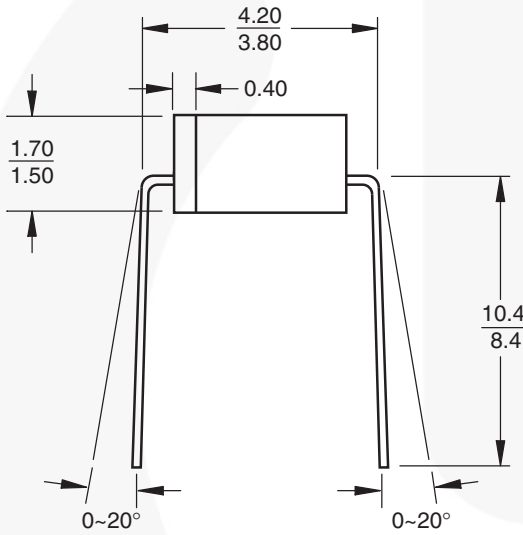
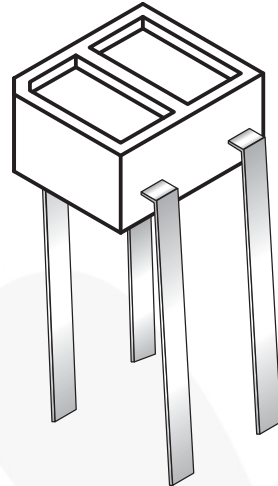
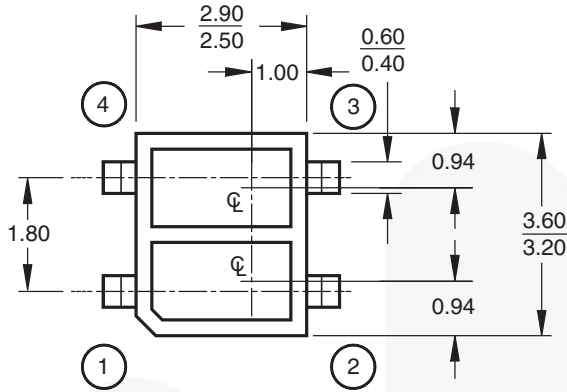

Notes:

1. Dimensions for all drawings are in millimeters.
2. Tolerance of ± 0.15 mm on all non-nominal dimensions.

Schematic

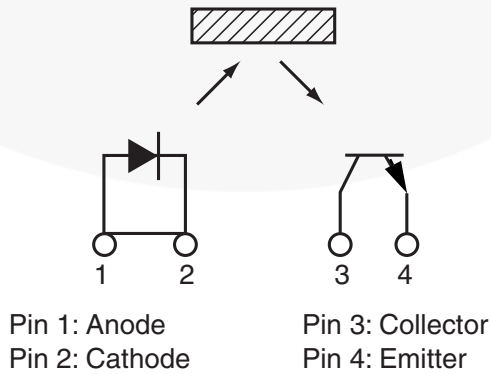

Absolute Maximum Ratings

Stresses exceeding the absolute maximum ratings may damage the device. The device may not function or be operable above the recommended operating conditions and stressing the parts to these levels is not recommended. In addition, extended exposure to stresses above the recommended operating conditions may affect device reliability. The absolute maximum ratings are stress ratings only. Values are at $T_A = 25^\circ\text{C}$ unless otherwise noted.

Symbol	Parameter	Value	Unit
T_{OPR}	Operating Temperature	-40 to +85	$^\circ\text{C}$
T_{STG}	Storage Temperature	-40 to +90	$^\circ\text{C}$
$T_{\text{SOL-I}}$	Soldering Temperature (Iron) ^(4, 5, 6)	240 for 5 sec	$^\circ\text{C}$
$T_{\text{SOL-F}}$	Soldering Temperature (Flow) ^(5, 6)	260 for 10 sec	$^\circ\text{C}$
EMITTER			
I_F	Continuous Forward Current	50	mA
V_R	Reverse Voltage	5	V
I_{FP}	Peak Forward Current ⁽⁷⁾	1	A
P_D	Power Dissipation ⁽³⁾	75	mW
SENSOR			
V_{CEO}	Collector-Emitter Voltage	30	V
V_{ECO}	Emitter-Collector Voltage	5	V
I_C	Collector Current	20	mA
P_D	Power Dissipation ⁽³⁾	50	mW

Electrical / Optical Characteristics

Values are at $T_A = 25^\circ\text{C}$ unless otherwise noted.

Symbol	Parameter	Conditions	Min.	Typ.	Max.	Unit
INPUT DIODE						
V_F	Forward Voltage	$I_F = 20\text{ mA}$		1.2	1.6	V
I_R	Reverse Leakage Current	$V_R = 5\text{ V}$			10	μA
λ_{PE}	Peak Emission Wavelength	$I_F = 20\text{ mA}$		940		nm
OUTPUT TRANSISTOR						
I_D	Collector-Emitter Dark Current	$I_F = 0\text{ mA}, V_{\text{CE}} = 20\text{ V}$			100	nA
COUPLED						
$I_{\text{C(ON)}}$	On-State Collector Current	$I_F = 20\text{ mA}, V_{\text{CE}} = 5\text{ V}^{(8)}$	0.10	0.40		mA
I_{CX}	Cross-Talk Collector Current	$I_F = 20\text{ mA}, V_{\text{CE}} = 5\text{ V}^{(9)}$			1	μA
$V_{\text{CE(SAT)}}$	Saturation Voltage				0.3	V
t_r	Rise Time	$V_{\text{CC}} = 5\text{ V}, I_{\text{C(ON)}} = 100\text{ }\mu\text{A}, R_L = 100\text{ k}\Omega$		20		μs
t_f	Fall Time			20		μs

Notes:

- Derate power dissipation linearly 1.00 mW/ $^\circ\text{C}$ above 25°C .
- RMA flux is recommended.
- Methanol or isopropyl alcohols are recommended as cleaning agents.
- Soldering iron 1/16" (1.6mm) from housing.
- Pulse conditions: $t_p = 100\text{ }\mu\text{s}$; $T = 10\text{ ms}$.
- Measured using an aluminum alloy mirror at $d = 1\text{ mm}$.
- No reflective surface at close proximity.