

# GP2Y0A710K0F

**Distance Measuring Sensor Unit**  
**Measuring distance: 100 to 550 cm**  
**Analog output type**



## ■Description

**GP2Y0A710K0F** is a distance measuring sensor unit, composed of an integrated combination of PSD (position sensitive detector), IRED (infrared emitting diode) and signal processing circuit.

The variety of the reflectivity of the object, the environmental temperature and the operating duration are not influenced easily to the distance detection because of adopting the triangulation method.

This device outputs the voltage corresponding to the detection distance. So this sensor can also be used as a proximity sensor.

## ■Features

1. Long distance type  
Distance measuring range : 100 to 550 cm
2. Analog output type
3. Package size : 58×17.6×22.5 mm
4. Consumption current : Typ. 30 mA
5. Supply voltage : 4.5 to 5.5 V

## ■Agency approvals/Compliance

1. Compliant with RoHS directive(2002/95/EC)

## ■Applications

1. Projector (for auto focus)
2. Robot cleaner
3. Auto-switch for illumination, etc.
4. Human body detector
5. Amusement equipment  
(Robot, Arcade game machine)

Notice The content of data sheet is subject to change without prior notice.

In the absence of confirmation by device specification sheets, SHARP takes no responsibility for any defects that may occur in equipment using any SHARP devices shown in catalogs, data books, etc. Contact SHARP in order to obtain the latest device specification sheets before using any SHARP device.

### Block diagram

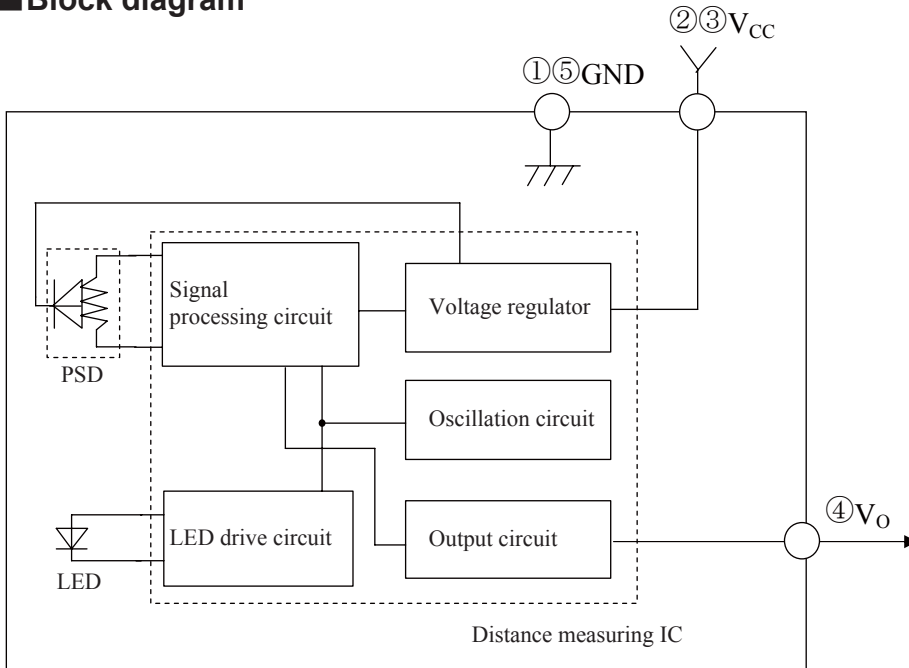

### Outline Dimensions

(Unit : mm)

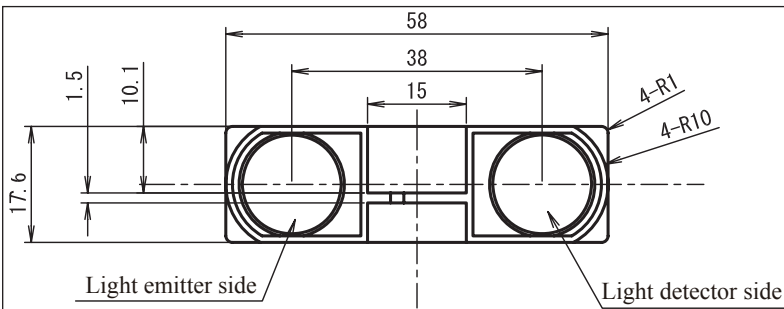

	Terminal	Symbol
①	Ground	GND
②	Supply voltage	V <sub>CC</sub>
③	Supply voltage	V <sub>CC</sub>
④	Output terminal voltage	V <sub>O</sub>
⑤	Ground	GND

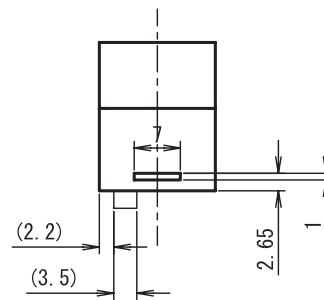
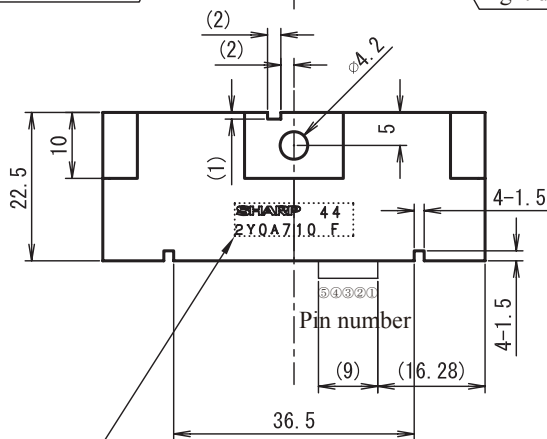

Stamp (Example)

SHARP 44  
2Y0A710 F  
Model name

Production month : Jan. to Sep. ; 1 to 9, Oct. ; X, Nov. ; Y, Dec. ; Z  
Production year : Last digit of prod. year

Stamp

Note 1. Unspecified tolerances shall be  $\pm 0.3$ mm.

Note 2. The connector is made by J.S.T. TRADING COMPANY, LTD. and its part number is B5B-ZR.

Note 3. The dimensions in parenthesis are shown for reference.

Product mass : approx. 9g