

# Varlogic NR6, NR12

Power factor controller

User manual



# Power Factor Controller NR6 / NR12 USER'S MANUAL

## Table of Contents

1. General.....	3
1.1 Safety.....	3
1.2 Description.....	3
2. Installation.....	5
3. Display.....	6
4. Start-up Procedure.....	6
5. Menu Operations.....	7
5.1 General.....	7
5.2 Main Menu.....	9
5.3 Bank Pre-Configuration.....	11
5.4 Commissioning.....	13
5.5 Auto Setup of Parameters.....	14
5.6 Manual Setup of Parameters.....	15
5.7 Measurement Menu.....	17
5.8 Parameter Update.....	18
5.9 Alarms Menu.....	19
5.10 Maintenance Menu.....	20
6. Miscellaneous.....	23
6.1 Stepping Programs.....	23
6.2 Manual calculation of response value.....	26
6.3 High Voltage use of NR6/NR12.....	27
7. Glossary.....	29
8. Technical specifications.....	31

# 1. General

## 1.1 Safety

The following precautions must be taken into account when installing and operating the controller

- The installation of the controller must be performed by a qualified electrician
- Do not touch the connectors when the controller is energized, make sure that the operating voltage is disconnected before touching any parts located on the rear side of the controller
- Do not open a live current circuit, this may cause dangerous overvoltages. Always short circuit the current transformer (CT) before replacing or removing the controller installed in a bank.
- Do not open the controller casing, there are no user serviceable parts inside

For better understanding of the terminology used, please refer to the Glossary (chapter 7) at the end of this manual.

## 1.2 Description

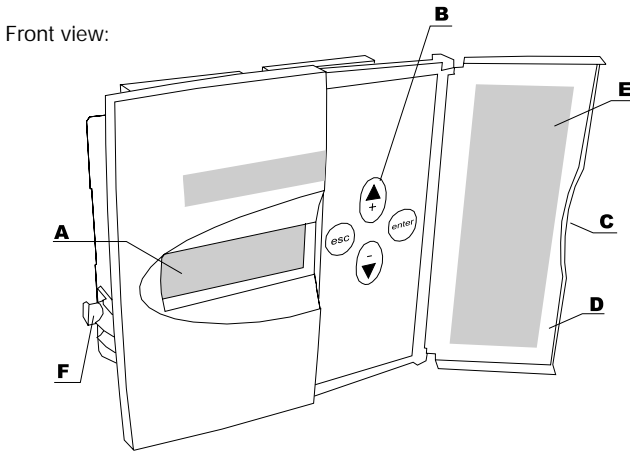

### Legend

A	Display
B	Keys
C	Opening of door
D	Door
E	Alarm information
F	Mounting bracket for panel mounting installation

# USER'S MANUAL

Rear view:

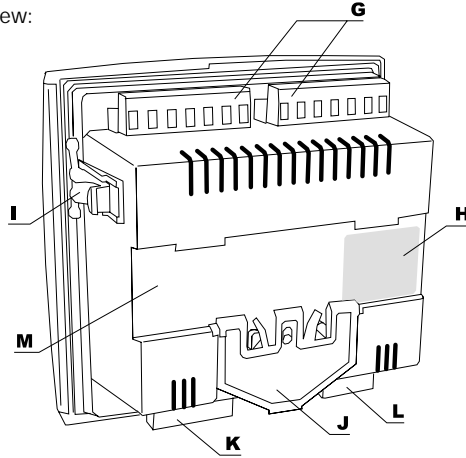

## Legend

G	Step output connectors
H	Specification label
I	Mounting bracket for panel mounting installation
J	Fixing spring for DIN-rail mounting
K	Current/voltage connection inputs
L	Fan and alarm outputs
M	DIN-rail mounting installation area

Side view:

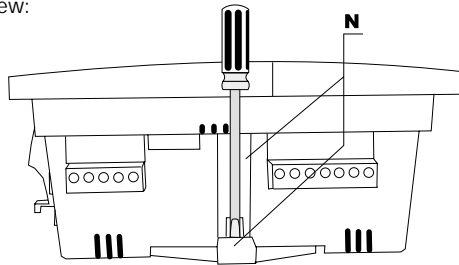

## Legend

N	Screwdriver guide
---	-------------------

See Chapter 8 for technical specifications.

## 2. Installation

The controller is designed for either panel (cut-out 138 x 138 mm) or DIN-rail installation. It is locked to the rail by a screwdriver-operated fixing spring and to a panel by a side fitting spring.

There are two ways of connecting the controller to the network.

- Voltage LN (Line – Neutral) (CT on the same line phase)
- Voltage LL (Line – Line) (CT on the third phase)

Incorrect connections can be automatically corrected by the controller when *Auto Setup* is selected from the main menu.

Caution: For use in HV network, look first at chapter 6.3

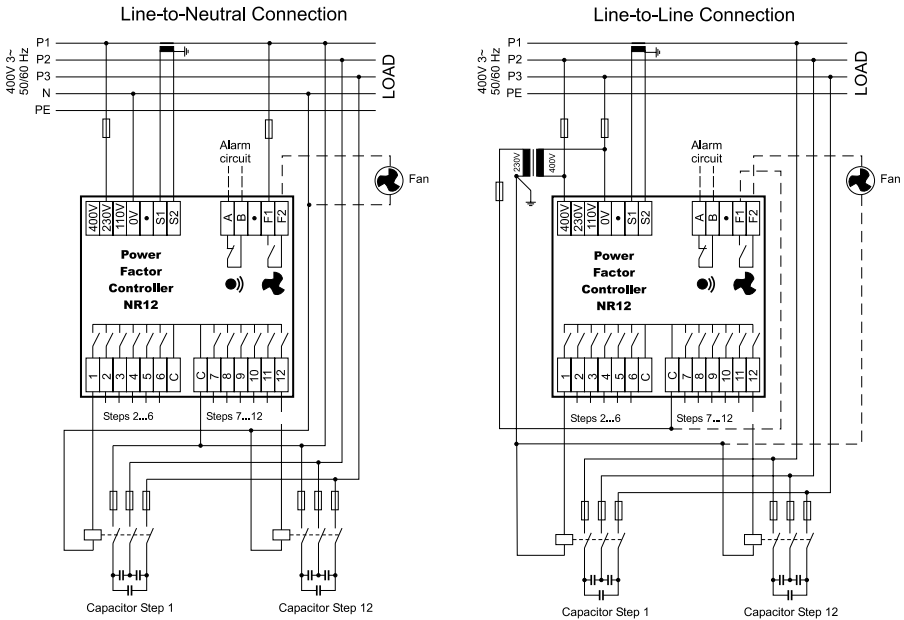

Figure 1: Controller connections

### 3. Display

The controller is equipped with a backlighted LCD-display.

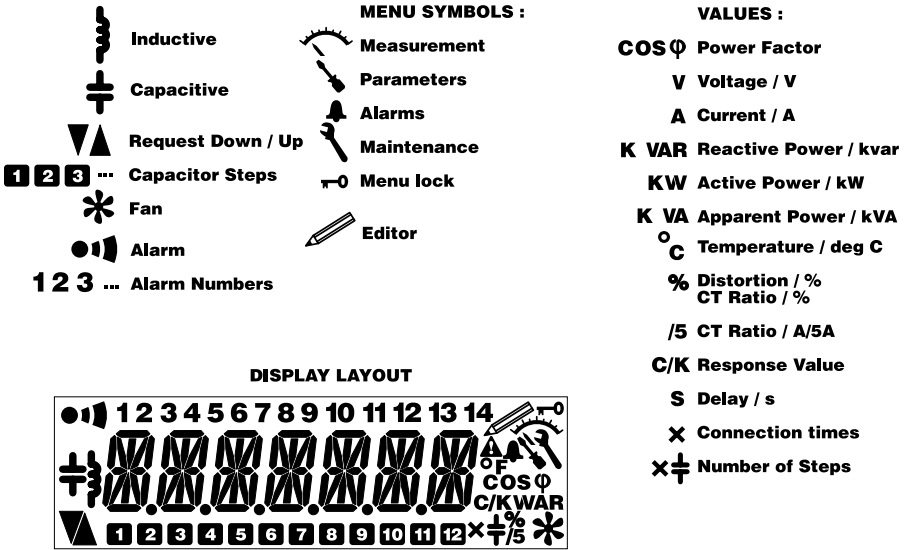

Figure 2 : Display layout and symbols

### 4. Start-up Procedure

Before connecting power, check the wiring of all controller terminals. Check carefully for correct operating voltage. Selection of wrong voltage input can permanently damage the controller.

After the first power switch-on, the controller will automatically ask for the language setting of the menu.

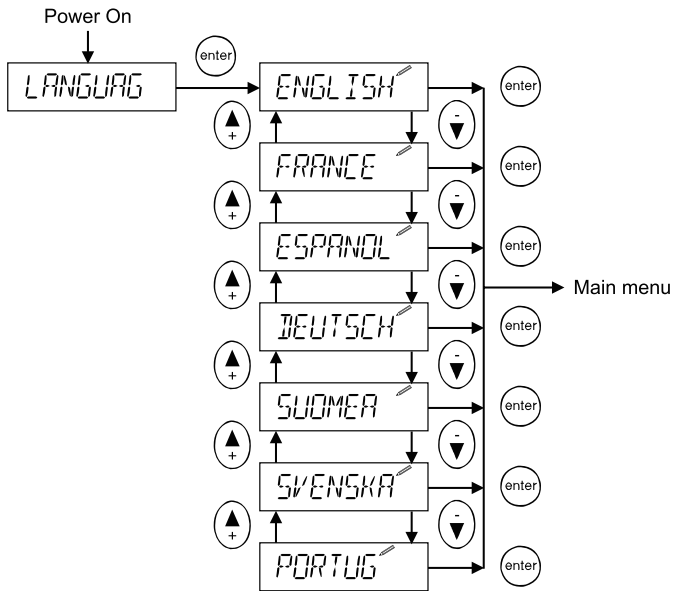

Figure 3: Language setting dialog

## 5. Menu Operations

### 5.1 General

#### Navigation between different menu levels

As a precaution against accidental use, the access of certain menus has been protected by a keylock, which is a special sequence of keystrokes enabling the use the particular menu item.

# USER'S MANUAL

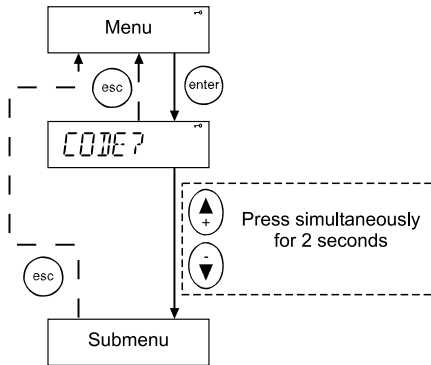

Figure 4: General way of entering the menu with a keylock

## Adjusting a value

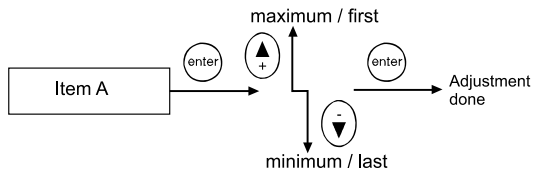

Figure 5: Adjusting a value

## Special case: The wiring editor

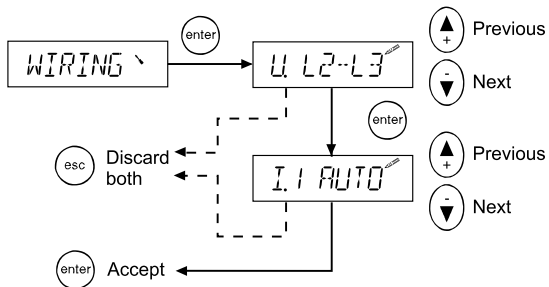

Figure 6: The wiring editor



## 5.2 Main Menu

The main menu contains all basic submenus required to set up and operate the controller.

Which menu to choose?

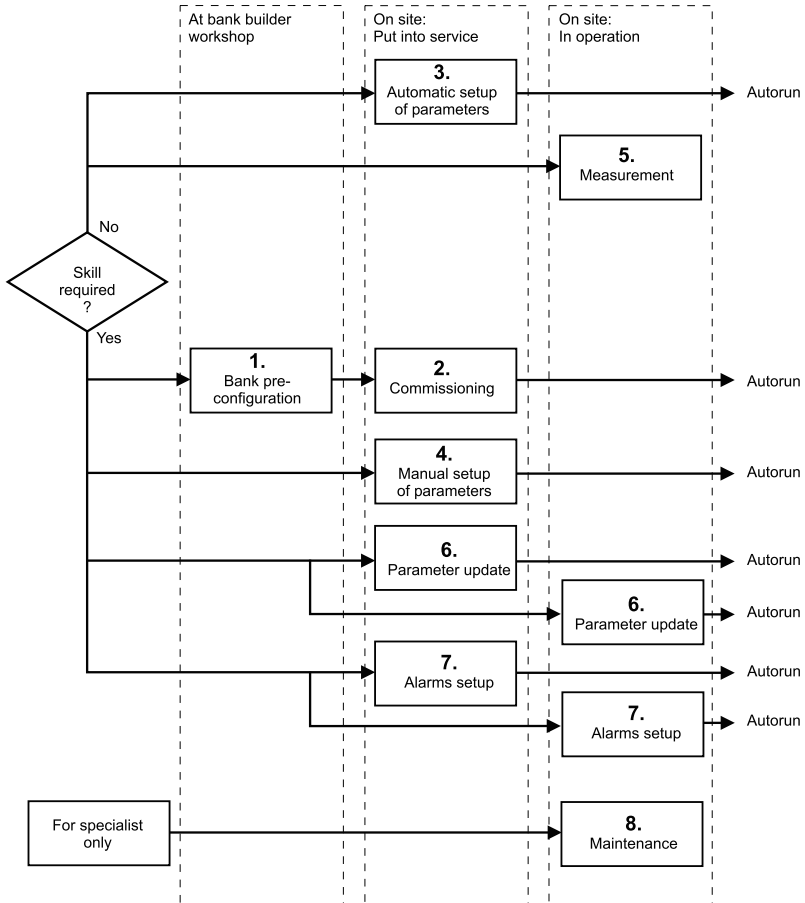

Figure 7: Required skills and menu selection

If bank preconfiguration is properly done, commissioning does not require any special skill.

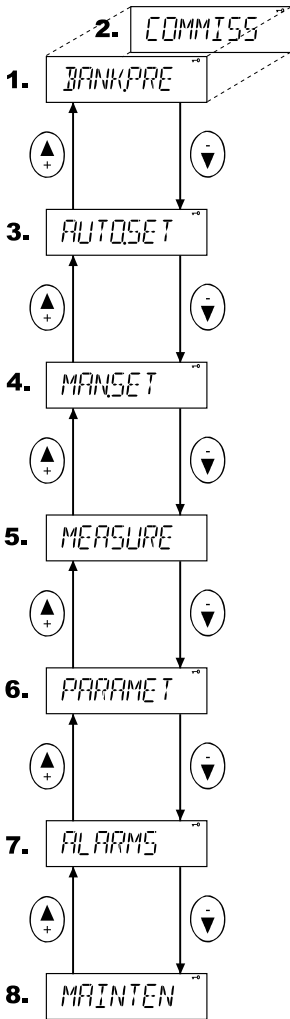

Figure 8: Main menu

**(1) Bank pre-configuration**

When factory settings have not been changed, this menu provides the bank builder the means of pre-configuring the bank at the workshop. After pre-configuration, this menu topic is replaced by

**(2) Commissioning**, by which the controller is taken into service.

**(3) Automatic setup of parameters**

In the event that the controller has not been pre-configured, an inexperienced user can automatically set up all the characteristics of the bank and bring it into service.

**(4) Manual setup of parameters**

In the event that the controller has not been pre-configured, an experienced user can manually set up all the characteristics of the bank and bring it into service.

**(5) Measurement**

The measurement menu contains the most common measurements taken from the network and provides some information about the bank. This is a read-only menu.

**(6) Parameter update**

At any time, an experienced user can access the most common operating parameters from this menu. Unlike the configuration and setup sequences, this is a menu allowing a free and unrestricted entry into all its items and should be used when an occasional parameter access is needed.

**(7) Alarm settings**

To adjust status and parameters of alarms.

**(8) Maintenance**

The maintenance menu provides some useful information about the usage of the bank, capacitors and contactors. Some auxiliary settings and action have also been provided. This menu is basically intended for use by the manufacturer's maintenance team.

### 5.3 Bank Pre-Configuration

This menu item is a forced sequence, meaning that all items must be accessed before the pre-configuration takes place.

---

*NOTE: Do not use of the Bank Pre-Configuration menu for HV network applications*

---

The sequence can be interrupted by pressing  key.

See Glossary (chapter 7) for parameters definitions.

# USER'S MANUAL

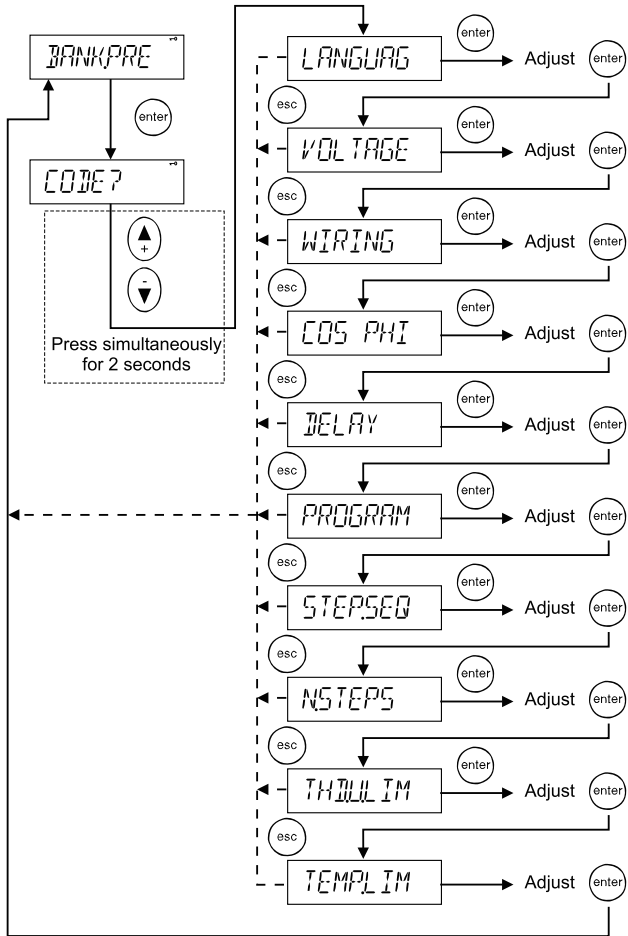

Figure 9: Bank pre-configuration

### 5.4 Commissioning

A pre-configured controller is put into service by this menu. The sequence contains an automatic parameter verification to check that the manually entered parameters agree with the network used.

See Glossary (chapter 7) for parameter definitions.

*NOTE: Do not use of the Commissioning menu for HV network applications*

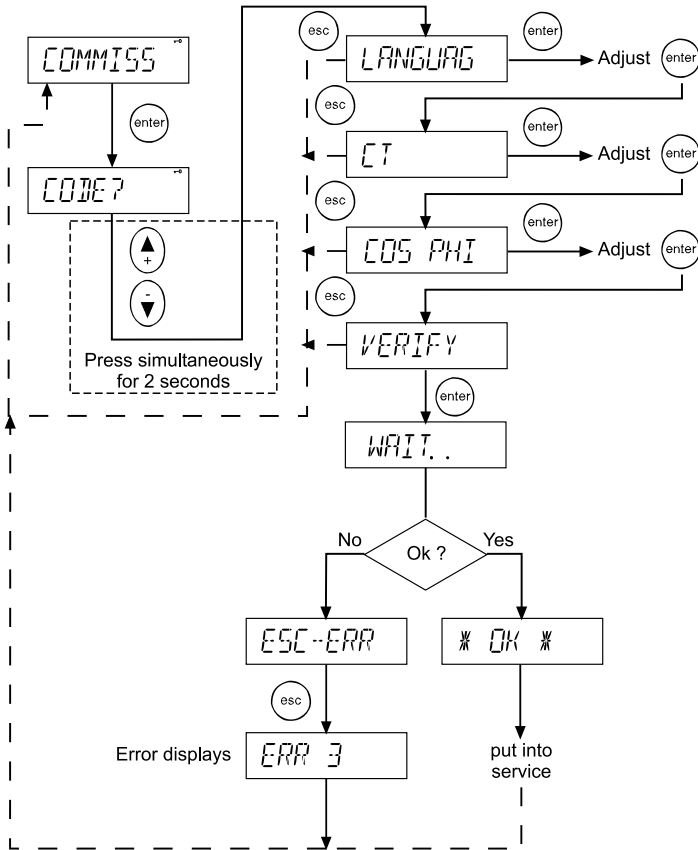

Figure 10: Commissioning

#### What to do in case of error ?

Error codes can help you to identify a problem and make corrections.

Code	Meaning	Action to do
ERR 1	Unstable network: The controller is unable to operate due to excessive load variations on the network. CT oversized.	<ul style="list-style-type: none"> <li>• Enter the parameter settings manually using <i>Parameter Update</i> menu.</li> <li>• Rerun the commissioning sequence</li> </ul>
ERR 2	Step size too small: The effect of the 1 <sup>st</sup> step cannot be measured. CT oversized, wrong wiring, inoperative steps.	<ul style="list-style-type: none"> <li>• Check wiring, CT, condition of capacitor steps (1<sup>st</sup> step)</li> </ul>
ERR 3	Sequence not found: Step ratio does not match available step sequences.	<ul style="list-style-type: none"> <li>• Check the condition and sizes of steps and contactors</li> </ul>
ERR 4	Step size too large: The ratio of measured step compared with the 1 <sup>st</sup> step is too large. Step sequence cannot be resolved.	<ul style="list-style-type: none"> <li>• Check the condition and sizes of steps and contactors</li> </ul>
ERR 5	Non-relevant autoseup process with this bank configuration	<ul style="list-style-type: none"> <li>• Use manual setup to confirm or correct the information obtained by autoseup</li> </ul>
ERR 6 to ERR 8	Reserved	
ERR 9	Wiring verify error: Controller wiring not correct.	<ul style="list-style-type: none"> <li>• Check the wiring of voltage- and current inputs</li> <li>• Check the <i>Wiring</i> setting from <i>Parameter Update</i> menu</li> </ul>
ERR 10	Step count error: The <i>Number of Steps</i> setting is incorrect.	<ul style="list-style-type: none"> <li>• Check the <i>Number of Steps</i> setting</li> <li>• Check the number of steps in the bank and the condition of steps</li> </ul>
ERR 11	Step sequence error: The step size ratios differ from the selected step sequence.	<ul style="list-style-type: none"> <li>• Check <i>Step Sequence</i> setting</li> <li>• Check step sizes used in the bank</li> </ul>
ERR 12	C/K value error.	<ul style="list-style-type: none"> <li>• Check the response value used</li> <li>• Check the size of 1<sup>st</sup> step in the bank</li> </ul>

### 5.5 Auto Setup of Parameters

The auto setup sequence is intended for inexperienced users so they can commission the bank with minimal prior knowledge. The user need only input three of the most common parameters and then launch an automatic search for the other parameters.

---

**NOTE:** *The use of Auto Setup of Parameters menu is forbidden on HV network applications*

---

In the event of error, see the *Commissioning Menu* (chapter 5.4).

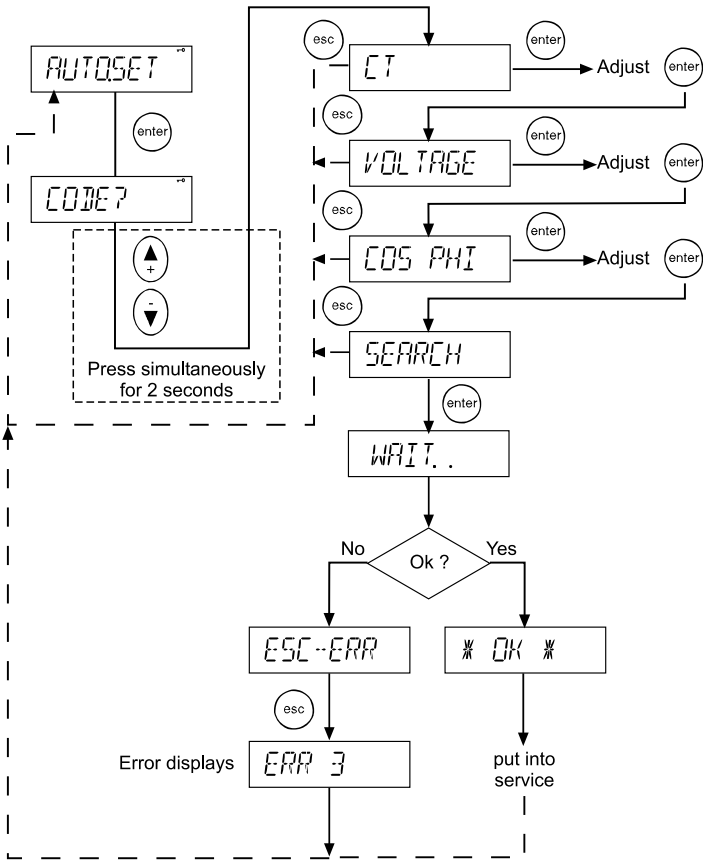

Figure 11: Auto setup of parameters

### 5.6 Manual Setup of Parameters

The manual setup sequence is intended for experienced users. There are nine important parameters to input before the controller can be taken into service. This sequence is completed by an automatic verification of the parameters entered earlier in this sequence.

This menu item is a forced sequence, meaning that all items must be accessed before the validation of the setup takes place.

The sequence can be interrupted by pressing key.

See Glossary (chapter 7), for parameter definitions.

In case of error, refer to the *Commissioning Menu*, chapter 5.4.

# USER'S MANUAL

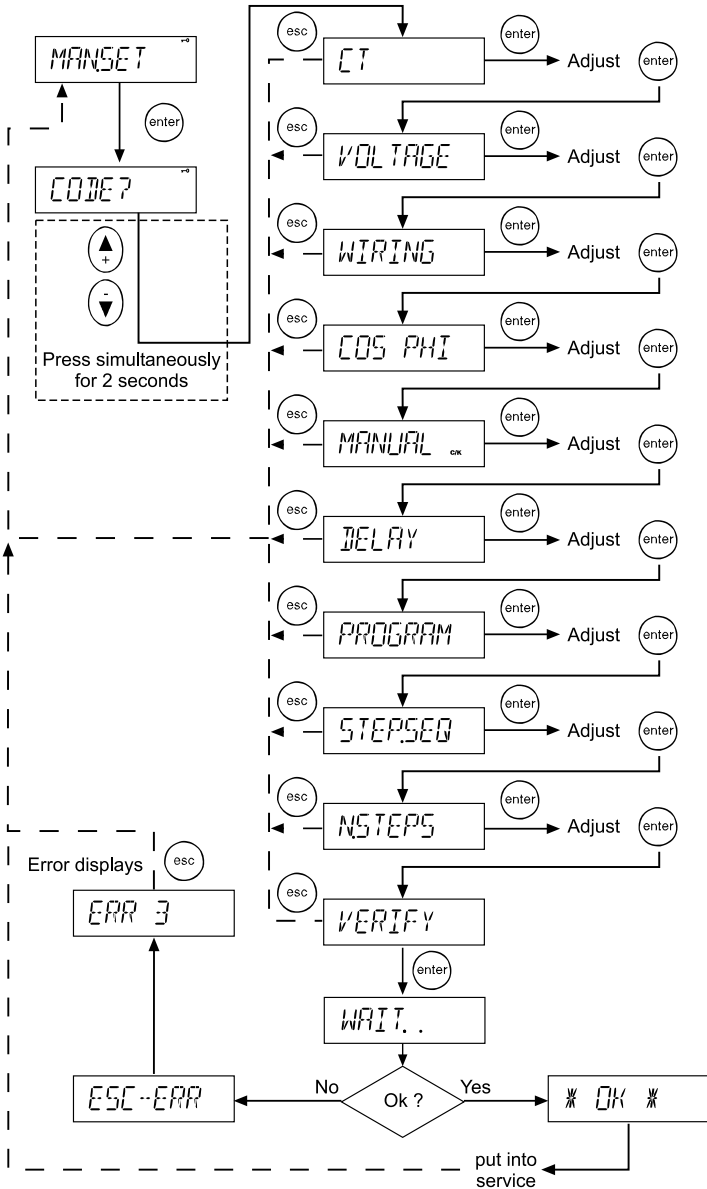

Figure 12: Manual setup of parameters



### 5.7 Measurement Menu

The measurement menu contains the most common measurements taken from the network. This is a read-only menu sequence.

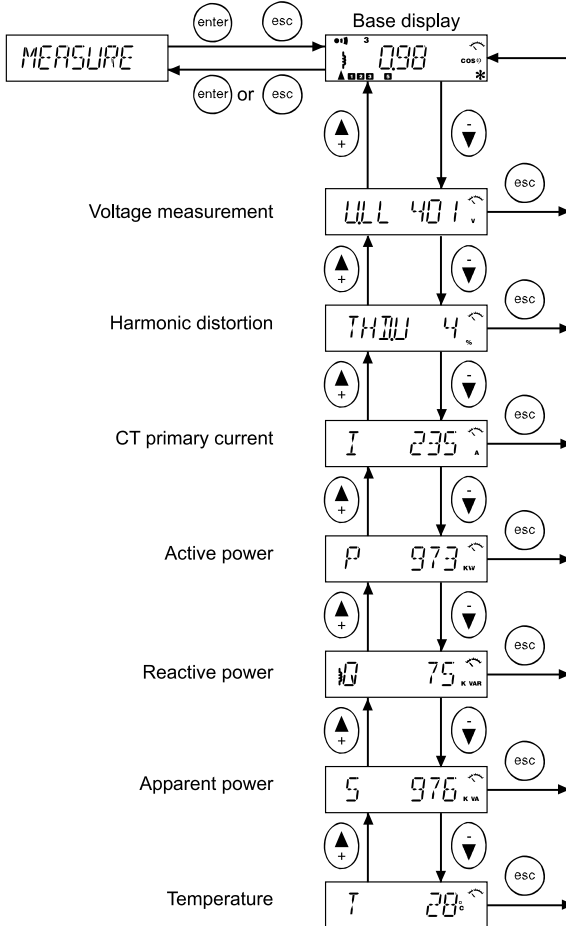

Figure 13: Measurement menu

### 5.8 Parameter Update

The most common operating parameters can be accessed from this menu.

Unlike the configuration and setup sequences presented earlier in this text, this is a menu allowing a free and unrestricted entry into all of its items and should be used when occasional parameter access is needed.

See Glossary (chapter 7), for parameter definitions.

In case of error, refer to the *Commissioning Menu*, chapter 5.4.

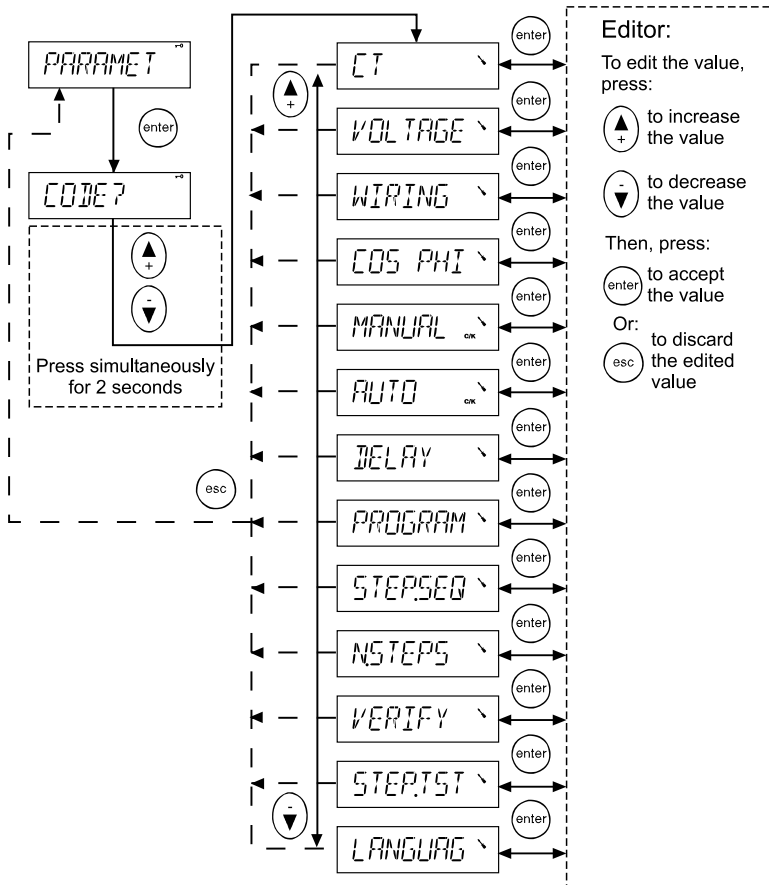



Figure 14: Parameter update

## 5.9 Alarms Menu

In Alarms menu, each individual alarm can be enabled or disabled.

Once an alarm condition is detected, the corresponding alarm number is shown at the upper part of the display, and the alarm symbol is on. The alarm relay is also activated.

---

**An alarm can be reset by an extended pressure of  key, this clears all passive alarms. If alarm condition is still active, the alarm cannot be reset.**

---

### List of alarms:

Alarm No.	Alarm	Possible cause	Controller action
1	Low power factor	<ul style="list-style-type: none"> <li>Wiring or LL/LN definition error</li> <li>Undersized bank</li> </ul>	
2	Hunting	<ul style="list-style-type: none"> <li>Too small C/K value</li> <li>Wrong program choice</li> <li>Defective capacitors (optimal program)</li> </ul>	Pauses regulation for 10 minutes
3	Abnormal Cos Phi	<ul style="list-style-type: none"> <li>Wiring mistake</li> <li>overcapacitive network (welded contactors)</li> <li>Too low current</li> </ul>	
4	Low voltage		Disconnection till voltage returns
5	Overcapacitive	<ul style="list-style-type: none"> <li>Wiring or LL/LN definition error</li> <li>Improper use of fixed steps</li> </ul>	
6	Wrong frequency	<ul style="list-style-type: none"> <li>Wrong or unstable network frequency detected at startup</li> </ul>	Stop regulation. No automatic restart
7	Overcurrent	<ul style="list-style-type: none"> <li>Undersized CT</li> </ul>	
8	Overvoltage		Temporary disconnection of steps
9	Overtemperature	<ul style="list-style-type: none"> <li>Ambient temperature too high</li> <li>Defective coolingssystem</li> </ul>	Temporary disconnection of steps
10	Voltage distortion	<ul style="list-style-type: none"> <li>Harmonic pollution</li> <li>Resonance</li> </ul>	Temporary disconnection of steps

Alarm contacts are

- closed when the controller is not energized
- opened when the controller is energized without alarm
- closed when the controller is energized with alarm

### ALRM.SET

- informs on the status of each alarm : enabled or disabled
- allows enabling or disabling of each individual alarm by setting it ON or OFF. If an alarm is set to OFF, it cannot cause an alarm under any condition. To allow a normal alarm response, the appropriate alarm must be enabled, i.e. set ON.

Some alarm triggering levels can be adjusted

Alarm No 9 (overtemperature ), with temperature limit setting

Alarm No 10 (voltage distortion ), with THD(U) limit setting

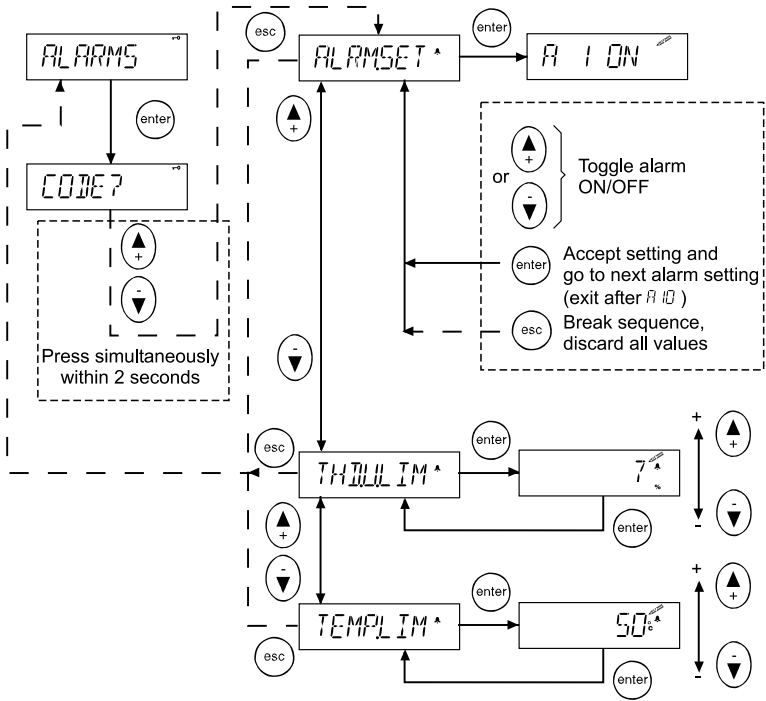

Figure 15: Alarms menu

### 5.10 Maintenance menu

The maintenance menu provides useful information about the usage of the bank, capacitors and contactors. Also, some auxiliary settings have been provided.

**CAUTION:** This menu access is dedicated to specialists.

**CAUTION:** *In case of installation in a HV bank (with VT), you must adjust the default factory settings. The reconnection delay must be changed to a larger value (e.g. 600 secs) to prevent destruction of capacitors.*

# USER'S MANUAL

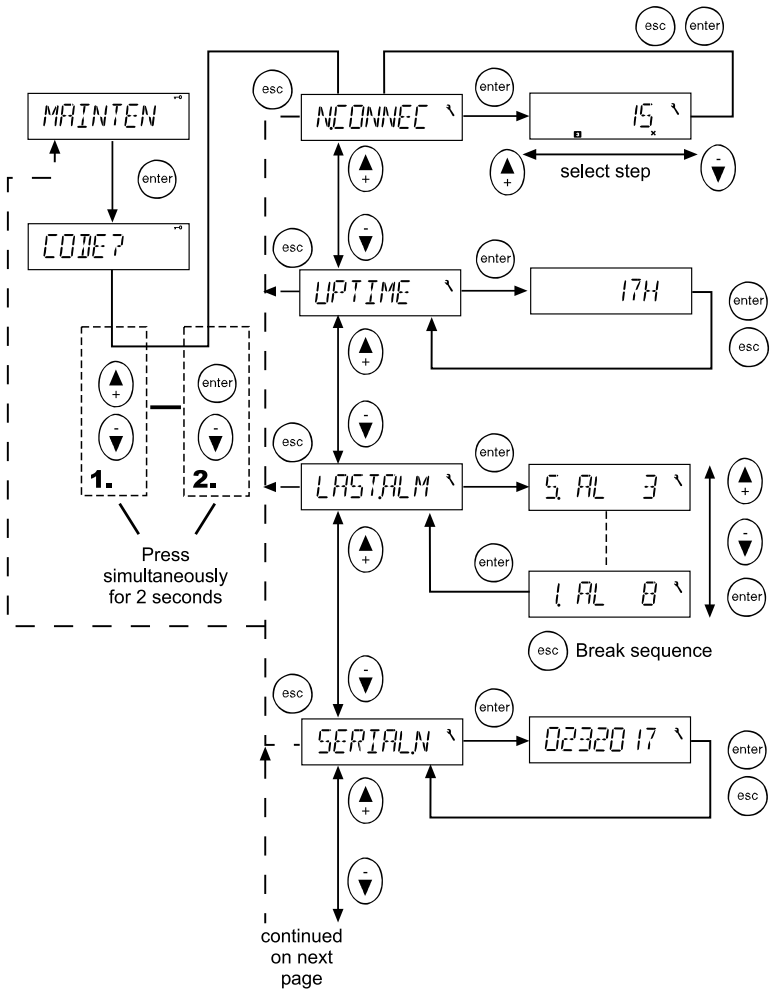

Figure 16/1: Maintenance menu

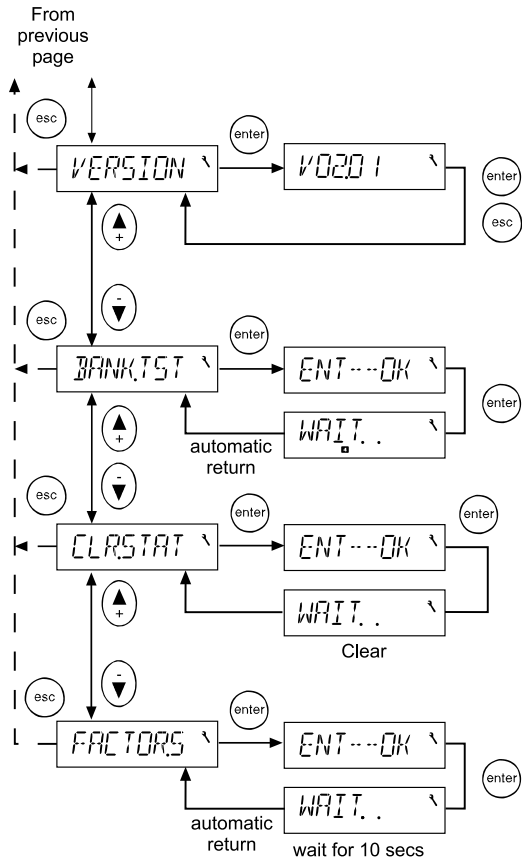

Figure 16/2: Maintenance menu

## 6. Miscellaneous

### 6.1 Stepping programs

The controller's algorithm will try to reach the target  $\cos\varphi$  inside a tolerance area dependant upon the C/K value. It reaches the value by switching on or off available relevant steps.

The regulation step program choice is as follows:

a) Stack Program (linear) :

All capacitor steps are of equal size (ex :1.1.1.1). The operation sequence obeys to a *last-in-first-out* (LIFO) principle. The first step connected will be the last one to be disconnected and vice versa. See Fig. 17

b) Normal program (2+ linear)

Normal program can be used on bank whose step ratio is 1.2.4.4.. The linear sequence starts with the 3<sup>rd</sup> step. The two first steps are used as fine-tuning. The controller always start by switching the first step then the second. Other steps are used successively See Fig. 18.

c) Circular A program

All capacitor steps are of equal size (ex :1.1.1.1). The operation sequence obeys the first-in-first-out (FIFO) principle. The first step connected will be the first one to be disconnected and vice versa. Then a circular sequence is followed. In order to operate correctly, the number of steps programmed into the controller must strictly comply with the number of physical steps See Fig. 19.

d) Circular B program (1+Circular)

Circular B program can be used on a bank whose step ratio is 1.2.2.2... The first step is used as tuning after the activating limit is exceeded. The circular sequence starts with the 2nd step.

Step	Step number					
demand	1	2	3	4	5	6
+	X					
+	X	X				
+	X	X	X			
+	X	X	X	X		
+	X	X	X	X	X	
+	X	X	X	X	X	X
-	X	X	X	X	X	
-	X	X	X	X		
-	X	X	X			
-	X	X				
+	X	X	X			
+	X	X	X	X		
+	X	X	X	X	X	
-	X	X	X	X		
-	X	X	X			
-	X	X				
-	X	X				
-	X					

Figure 17: Stack program - Operation sequence 1:1:1:1

Step	Step number					
demand	1	2	3	4	5	6
+	X					
+	X	X				
+	X	X	X			
+	X	X	X	X		
-		X	X	X		
-			X	X		
+	X		X	X		
+	X	X	X	X		
+	X	X	X	X	X	
-		X	X	X	X	
-			X	X	X	
-			X	X		
-			X	X		
-			X			

Figure 18: Normal program - Operation sequence 1:2:4:4

Step	Step number					
demand	1	2	3	4	5	6
+	X					
+	X	X				
+	X	X	X			
+	X	X	X	X		
-		X	X	X		
-			X	X		
+			X	X	X	
+			X	X	X	X
-				X	X	X
-					X	X
+	X				X	X
+	X	X			X	X
-	X	X				X

Figure 19: Circular A program - Operation sequence 1:1:1

Step	Step number					
demand	1	2	3	4	5	6
+	X					
+	X	X				
-	X	X	X			
-		X	X			
+	X	X	X			
+	X	X	X	X		
-		X	X	X		
-			X	X		
-				X		
+	X			X		
+	X			X	X	
+	X			X	X	X
+	X	X		X	X	X
-		X		X	X	X
-		X			X	X
-		X			X	X
-		X				X

Figure 20: Circular B program - Operation sequence 1:2:2

e) Optimal Program :

The optimal program operates with many step configurations:

- 1.1.1.1.1                      1.2.2.2.2                      1.2.4.4.4                      1.2.4.8.8                      1.1.2.2.2
- 1.1.2.3.3                      1.1.2.4.4                      1.2.3.3.3                      1.2.3.4.4                      1.2.3.6.6

The target  $\cos \varphi$  power is reached using the fewest number of steps in minimal time. Like the circular program, this algorithm equalises the usage of steps.

This program uses optimally selected steps sizes when approaching the target power and at the same time the response delays are shortened, particularly if there is a large requirement for kvar or if the network suddenly becomes capacitive.

Comparison between normal and optimal program:

Normal program will reach the  $\cos \varphi$  target value by successive connection/disconnection of kvar corresponding to the smallest step value.

Optimal program will reach the target  $\cos \varphi$  value by successive connection/disconnection of kvar corresponding to the highest relevant and available step value



## Optimal Stepping Program

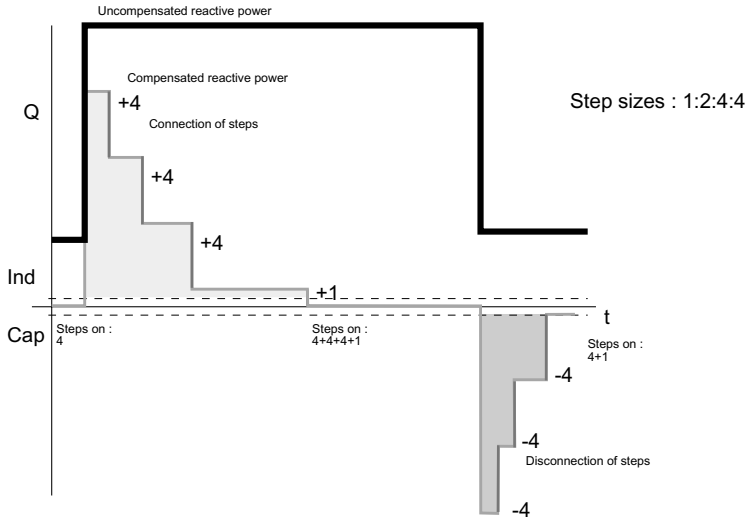

## Normal Stepping Program

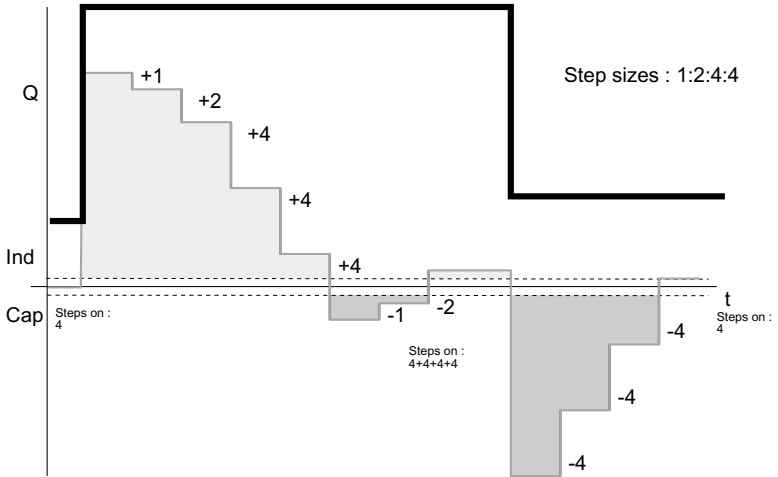

Figure 21: Regulation example - Optimal vs. Normal

## 6.2 Manual calculation of response value

Normally the response value, more generally known as the C/K value, is set automatically as a part of the *Auto Setup* sequence, but there are cases when these values must be entered manually. The correct value can be calculated using an equation requiring the 1<sup>st</sup> step size (in vars), line-to-line voltage of the network used (in volts) and the CT ratio as follows

$$C / K = \frac{Q_{1st}}{I_1/5A \times U_{LL} \times \sqrt{3}}$$

where  $Q_{1st}$  = size of 1<sup>st</sup> step in vars  
 $U_{LL}$  = line-to-line voltage in volts  
 $I_1/5A$  = CT ratio

Alternatively, the C/K value can be taken from the table below (valid for 400 V networks)

n1/n2	Smallest step (kvar)							
	12,5	20	25	30	40	50	60	100
100/5	0,91	1,44						
150/5	0,60	0,96	1,20	1,44				
200/5	0,45	0,72	0,90	1,08	1,44			
250/5	0,36	0,58	0,72	0,87	1,16	1,44		
300/5	0,30	0,48	0,60	0,72	0,96	1,20	1,44	
400/5		0,36	0,45	0,54	0,72	0,90	1,08	
500/5		0,29	0,36	0,43	0,58	0,72	0,87	1,44
600/5			0,30	0,36	0,4	0,60	0,72	1,20
800/5				0,27	0,36	0,45	0,54	0,90
1000/5					0,29	0,36	0,43	0,72
1500/5						0,24	0,29	0,48
2000/5							0,22	0,36
2500/5								0,29
3000/5								0,24

Table 1: C/K-values for 400 V network

By successive connections (or disconnections) of steps we adjust the reactive power between two symmetrical limits corresponding to response value

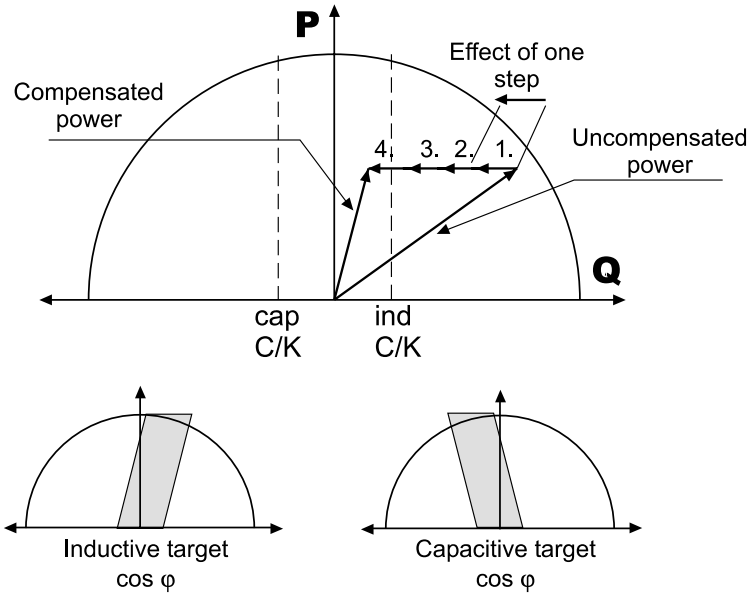

Figure 22: Compensation example and consequences

### 6.3 High Voltage use of NR6/NR12

This controller is primarily intended for LV network, but may be used in HV networks under the commissioner's full responsibility, if the following points are taken into account. Connections must employ VT and CT with respect to the following figure.

In HV applications the power values displayed in Measurement Menu represent only the secondary side values of the VT. To avoid potential misunderstandings, set the CT ratio to percentage scale.

Safety (or reconnection) delay must be adapted to the value of the discharge resistors of the capacitors, the most usual value is 10 minutes (600 seconds). The controller's default response delay is adapted for LV use. Using too short a response delay may damage the capacitors.

Important:

- the whole commissioning process must be performed using the Manual setup menu and Parameter menu
- the commissioner should not use Bank Pre-Configuration and Commissioning menus
- the use of Auto Setup menu is strictly forbidden to prevent capacitor destruction

HV connection of NR6/NR12

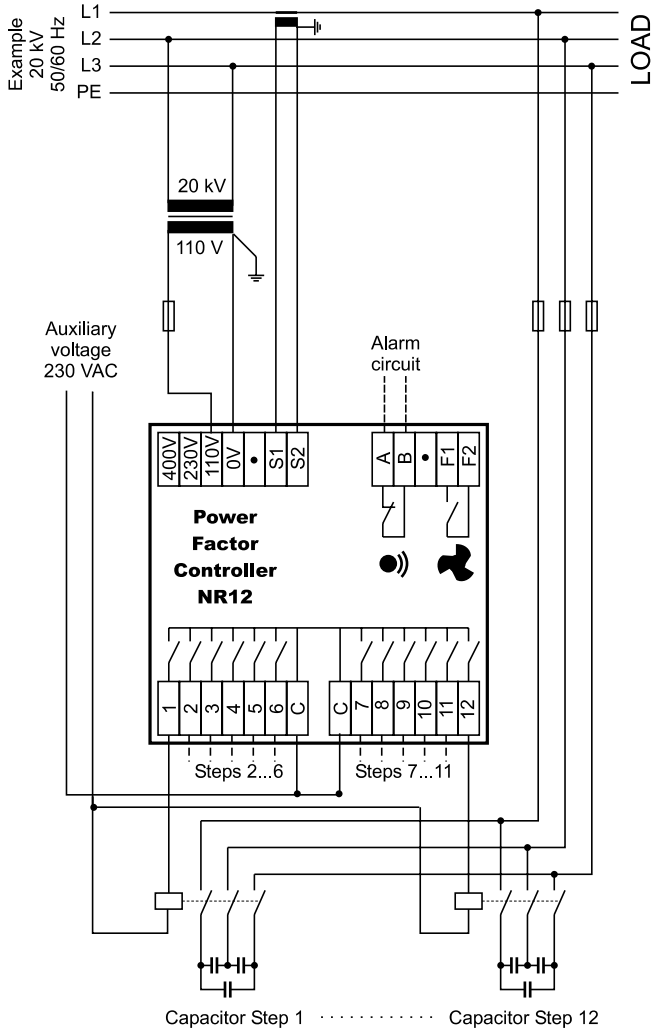

Figure 23: HV use of the controller

## 7. Glossary

<u>Display information</u>	<u>Long form text</u>	<u>Min value</u>	<u>Default value</u>	<u>Max value</u>
ALARMS	Alarms Menu			
ALRM.SET	Alarm Setup (Enable/Disable)			
AUTO	Automatic search of C/K response value			
AUTO.SET	Automatic Setup Sequence			
BANK.PRE	Bank Pre-configuration Sequence Menu			
BANK.TST	Bank Test: each step is automatically connected and disconnected in turn. This facilitates testing of the operation of each capacitor step contactor. See also <i>Step Test</i> .			
CIRC.A	Circular A stepping program			
CIRC.B	Circular B stepping program			
C/K	Response value, normally set up automatically by the controller			
CLR.STAT	Clear Statistics			
COMMISS	Commissioning Sequence Menu			
COS PHI	Target cos $\phi$ value	0,8ind	1.00	0,9cap
CT	Current Transformer primary setting, xxx/5 A	25/5	%	6000/5
DELAY	Safety Delay or reconnection delay. Response delay is fixed 20% of reconnection delay. The default value corresponds to capacitors with internal discharge resistors 50V 1 min	10s	50s	600s
ENGLISH	Language names: English, for instance			
ERR NN	Error in parameter search or verify. NN= error number			
FACTOR.S	Restore Factory Settings			
IGNORED	The controller does not require the information about step sequence for any program outside <i>Optimal</i> . The controller defines it automatically.			
I HIGH	Current too high			>115% $I_N$
I LOW	Current too low	<2,5% $I_N$		
LANGUAG	Language Selection for menus			
LL	Line to Line connection			
LN	Line to Neutral connection			
LV	Low Voltage			
MAINTEN	Maintenance Menu			
MAN.SET	Manual Setup Sequence Menu			
MANUAL	Manual setting of C/K response value. See further	0,01	0,50	1,99
MEASURE	Measurements Menu			

## USER'S MANUAL

<u>Display information</u>	<u>Long form text</u>	<u>Min value</u>	<u>Default value</u>	<u>Max value</u>
N.CONNEC	Number of Connections			
N.STEPS	Number of used steps	1	6/12	12
NORMAL	Normal, Standard stepping program			
OPTIM	Optimal program			
PARAMET	Parameters Menu			
PROGRAM	Selection of suitable stepping program between (see 6.1 Stepping programs) The controller's algorithm will try to reach the target $\cos \varphi$ inside a tolerance area dependant upon the C/K value. It reaches the value by switching on or off available relevant steps.  Stack Normal Circular A Circular B Optimal			
SEARCH	Search (response value, step sizes, wiring...)			
SERIAL.N	Serial Number of the product (for internal manufacturer use)			
STACK	Linear stepping program			
STEP.SEQ	Setting of Step Size Sequence 1.1.1.1.1 - 1.1.2.2.2 - 1.1.2.3.3 - 1.1.2.4.4 - 1.2.2.2.2 - 1.2.4.4.4 - 1.2.4.8.8 - 1.2.3.3.3 - 1.2.3.4.4 - 1.2.3.6.6 This concerns the Optimal program. Step sequence are predefined with other programs and modification request are not then taken into account			
STEP.TST	Step Test: each step can be manually connected and disconnected. This facilitates testing of the operation of each capacitor step contactor. See also <i>Bank Test</i> .			
TEMPLIM	Temperature Limit (adjustable) Fan switch-on limit is 15°C lower than temperature limit.	20°C	50°C	60°C
THD.U	Total Harmonic Distortion of Voltage			
THD.U.LIM	Maximum Harmonic Distortion of Voltage (adjustable)	5%	7%	20%
U LOW	Voltage too low	<85%U <sub>N</sub>		
UPTIME	Uptime (Power On Hours)			
VERIFY	Automatic verification of parameters			
VERSION	Software version number (for internal manufacturer use)			
VOLTAGE	Input Voltage reference value for voltage alarms	80V	400V	460V
WIRING	Connections of voltage and current inputs. Example: U.L2-L3 (Voltage connected between phase 2 and 3) Example: I.1.AUTO (Current connected to phase 1 with automatic polarity selection) Current polarity selections: DIR = direct connection INV = inverted connection AUTO = automatic polarity (defined by controller)			

## 8. Technical specifications

Number of steps	6 or 12
Dimensions	155 x 155 x 70 mm
Frequency	48...52 Hz, 58...62 Hz
Measuring current	0..5 A
Measuring and supply voltages	88...130 V 185...265 V 320...460 V
Relay outputs	120 Vac/5A, 250 Vac/2A, 400 Vac/1A 110 Vdc/0,3A, 60 Vdc/0,6A, 24 Vdc/2A
Display	LCD glass with 160 symbols, backlighted
Protection class	IP41 front panel, IP20 rear part
Target cos $\varphi$ -range	0,85 ind...1,00...0,90 cap
Response limits, C/K	0,01...1,99 symmetrical
Reconnection delay	10...600 s
Response delay	20 % of reconnection delay, min. 10 s
Displayed measurements	cos $\varphi$ , P, Q, S, THD(U), temperature
Installation method	Panel installation, DIN-rail installation
Casing	Impact resistant PC/ABS, UL94V-0
Operating temperature range	0...60°C
Alarm log	List of 5 last alarms
Step counters	Yes
Fan control with dedicated relay	Yes
Accuracy (of FS)	Is: 5% Iq: 5% U/I-samples: 5% Phase: 5° Distortion: $\pm 3$ dB (up to 11 <sup>th</sup> ) Temperature: $\pm 3^\circ\text{C}$
CT setting range	25/5...6000/5
Power outage detection	Reaction time > 15 ms
Approvals	IEC 61010-1 IEC 61000-6-2 IEC 61000-6-4 IEC 61326

**Schneider Electric Industries SAS**

As characteristics and dimensions of our products are constantly changing, please contact our offices for confirmation.