

# Rexroth IndraDrive C Drive Controllers HCS02.1, HCS03.1

**R911314905**  
Edition 01

## Operating Instructions



<b>Title</b>	Rexroth IndraDrive C Drive Controllers HCS02.1, HCS03.1
<b>Type of Documentation</b>	Operating Instructions
<b>Document Typecode</b>	DOK-INDRV*-FU*****-IB01-EN-P
<b>Internal File Reference</b>	Document Number, 120-2400-B327-01/EN; Mat. No.: R911314905
<b>Purpose of Documentation</b>	This documentation describes the mounting, installation, commissioning, parameterization and troubleshooting of Rexroth IndraDrive controllers on the basis of the power sections HCS02 or HCS03 and the control sections BASIC OPENLOOP or BASIC PROFIBUS with comfort control panel.

**Record of Revisions**

Description	Release Date	Notes
DOK-INDRV*-FU*****-IB01-EN-P	06-2006	First Release

**Copyright** © Bosch Rexroth AG 2006

Copying this document, giving it to others and the use or communication of the contents thereof without express authority, are forbidden. Offenders are liable for the payment of damages. All rights are reserved in the event of the grant of a patent or the registration of a utility model or design (DIN 34-1).

**Validity**

The data specified above only serve to describe the product. No statements concerning a certain condition or suitability for a certain application can be derived from our information. The given information does not release the user from the obligation of own judgement and verification. It must be remembered that our products are subject to a natural process of wear and aging.

**Published by**

Bosch Rexroth AG  
Bgm.-Dr.-Nebel-Str. 2 • D-97816 Lohr a. Main  
Telephone +49 (0)93 52/40-0 • Tx 68 94 21 • Fax +49 (0)93 52/40-48 85  
<http://www.boschrexroth.de/>  
Dept. EDY1 (RR/US/BB)

**Note**

This document has been printed on chlorine-free bleached paper.

# Contents

<b>1</b>	<b>Introducing the Products</b>	<b>1-1</b>
1.1	Introduction .....	1-1
	Terms, Basic Principles .....	1-1
1.2	Rexroth IndraDrive Hardware Platform .....	1-6
	Drive Controllers .....	1-6
	Motors and Measuring Systems .....	1-7
	Master Communication.....	1-8
1.3	Rexroth IndraDrive Firmware Platform .....	1-8
	Type Code .....	1-8
	Functions Overview .....	1-9
1.4	Rexroth IndraDyn Motors.....	1-12
	Housing Motors.....	1-12
	Kit Motors.....	1-12
1.5	Third-Party Motors at IndraDrive Controllers.....	1-13
	General Information on Third-Party Motors.....	1-13
	Requirements on Third-Party Motors .....	1-14
	Requirements on the Encoder of the Third-Party Motor .....	1-17
	Notes on Selection and Commissioning.....	1-17
1.6	Approval, Listing .....	1-18
	Conformities.....	1-18
	C-UL-US-Listing.....	1-18
<b>2</b>	<b>Important Directions for Use</b>	<b>2-1</b>
2.1	Appropriate Use.....	2-1
	Introduction .....	2-1
	Areas of Use and Application .....	2-2
2.2	Inappropriate Use .....	2-2
<b>3</b>	<b>Safety Instructions for Electric Drives and Controls</b>	<b>3-1</b>
3.1	General Information .....	3-1
	Using the Safety Instructions and Passing them on to Others.....	3-1
	Instructions for Use.....	3-1
	Explanation of Warning Symbols and Degrees of Hazard Seriousness .....	3-3
	Hazards by Improper Use.....	3-4
3.2	Instructions with Regard to Specific Dangers.....	3-5
	Protection Against Contact with Electrical Parts .....	3-5
	Protection Against Electric Shock by Protective Low Voltage (PELV).....	3-6
	Protection Against Dangerous Movements.....	3-7

	Protection Against Magnetic and Electromagnetic Fields During Operation and Mounting .....	3-9
	Protection Against Contact with Hot Parts .....	3-10
	Protection During Handling and Mounting.....	3-11
	Battery Safety .....	3-11
	Protection Against Pressurized Systems .....	3-12
<b>4</b>	<b>Identification, Transport, Storage, Installation Conditions</b>	<b>4-1</b>
4.1	Identification.....	4-1
	Type Code .....	4-1
	Type Plates.....	4-4
4.2	Transport and Storage.....	4-6
	Transport of the Devices .....	4-6
	Storage of the Devices .....	4-6
4.3	Installation Conditions.....	4-7
	Ambient and Operating Conditions.....	4-7
	Compatibility with Foreign Matters .....	4-9
<b>5</b>	<b>Electrical Data</b>	<b>5-1</b>
5.1	Power Sections.....	5-1
	Type Current and Connected Load .....	5-1
	Control Voltage Supply.....	5-2
	Power Voltage Supply- Mains Connection .....	5-3
	Limited Length of Motor Power Cables .....	5-4
5.2	Control Sections .....	5-6
	Relay Contact Type 1 .....	5-6
	Relay Contact Type 2 .....	5-6
	Relay Contact Type 3 .....	5-7
	Digital Inputs/Outputs .....	5-7
	Analog Inputs/Outputs .....	5-9
5.3	Additional Components.....	5-15
	Mains Filter HNF.....	5-15
	Mains Filter (-Combination) HNK.....	5-16
	Mains Choke HNL01.1E (feeding).....	5-16
	Mains Choke HNL01.1E-****-S (Current-Compensated) .....	5-17
	Braking Resistor HLR .....	5-17
	Motor Filter HMF.....	5-26
<b>6</b>	<b>Mounting and Installation</b>	<b>6-1</b>
6.1	Mounting .....	6-1
	Dimensions – Power Sections.....	6-1
	Dimensions – Mains Filter HNF .....	6-7
	Dimensions – Mains Choke HNL01.1E (infeeding) .....	6-9
	Dimensions – Standard Braking Resistors HLR01.1.....	6-12
	Dimensions – Reinforced Braking Resistors HLR01.1 .....	6-14
	Dimensions – Motor Filter HMF.....	6-17
	Combination of Drive Controllers of the Rexroth IndraDrive C Product Range .....	6-22

	Multiple-Line Arrangement of Drive Controllers .....	6-24
6.2	Electrical Installation .....	6-25
	Rules for Design of Installations with Drive Controllers in Compliance with EMC .....	6-25
	EMC-Optimal Installation in Facility and Control Cabinet.....	6-26
	Ground Connections.....	6-32
	Installing Signal Lines and Cables.....	6-33
	General Measures of Radio Interference Suppression for Relays, Contactors, Switches, Chokes, Inductive Loads.....	6-34
	Installing the 24V Supply .....	6-35
	Connection Diagram.....	6-36
	Connections and Connectors .....	6-38
	Accessories HAS.....	6-67

## 7 Commissioning and Parameterization 7-1

7.1	Basics .....	7-1
	Control Panels .....	7-1
	Parameters .....	7-1
	Master Communication Interfaces.....	7-3
	Parameterization Mode / Operating Mode .....	7-4
	Default Settings in the Motor Encoder Data Memory ("Load Defaults Procedure").....	7-9
7.2	Parameterization.....	7-12
	Control Panels .....	7-12
	Menu Structure .....	7-16
7.3	Overview of Parameters – Base Package.....	7-36
	S-0-0000 – S-0-0100 .....	7-36
	S-0-0101 – S-0-0200 .....	7-41
	S-0-0201 – S-0-0300 .....	7-45
	S-0-0301 – S-0-0400 .....	7-47
	S-0-0401 – S-0-1000 .....	7-50
	P-0-0001 – P-0-0689 (General Functions).....	7-51
	P-0-0690 – P-0-0899 (Synchronization Mode).....	7-85
	P-0-1100 – P-0-1299 (Velocity Control) .....	7-87
	P-0-1500 – P-0-1599 (General Device Parameters).....	7-96
	P-0-2000 – P-0-2999 (General Device Parameters).....	7-96
	P-0-3600 – P-0-4095 (General Device Parameters).....	7-97
7.4	Basic Functions .....	7-108
	Serial Communication .....	7-108
	Master Communication.....	7-110
	Profile Types.....	7-114
	Motor Control.....	7-117
	Scaling of Physical Data.....	7-118
7.5	Voltage-Controlled Operation (Open-Loop U/f Control) .....	7-121
	Overview.....	7-121
	Automatic Setting of Motor Control Parameters.....	7-122
7.6	Closed-Loop Axis Control (Closed-Loop Operation) .....	7-131
	Automatic Setting of Axis Control .....	7-136
7.7	Positioning Block Mode .....	7-137

<b>8</b>	<b>Diagnostic and Service Functions</b>	<b>8-1</b>
8.1	Diagnostic System .....	8-1
	Diagnostic Status Messages .....	8-1
	Diagnostic Command Messages .....	8-1
	Warnings .....	8-1
	General Description of Error Messages and Error Reactions .....	8-2
8.2	Recommended Actions for Operating States, Activities and Reactions of the Drive Controller .....	8-5
8.3	Troubleshooting .....	8-21
	Check Drive Components .....	8-21
	Replacing Devices .....	8-21
	Cables .....	8-23
	Replacing the Firmware .....	8-24
	Firmware Release Update .....	8-25
	Firmware Version Upgrade .....	8-29
	Possible Problems during Firmware Replacement .....	8-35
8.4	Service and Maintenance .....	8-36
	Deactivation .....	8-36
	Dismantling .....	8-36
	Disposal .....	8-37
	Environmental Protection .....	8-37
<b>9</b>	<b>Service &amp; Support</b>	<b>9-1</b>
9.1	Helpdesk .....	9-1
9.2	Service-Hotline .....	9-1
9.3	Internet .....	9-1
9.4	Vor der Kontaktaufnahme... - Before contacting us... .....	9-1
9.5	Kundenbetreuungsstellen - Sales & Service Facilities .....	9-2
<b>10</b>	<b>Index</b>	<b>10-1</b>

# 1 Introducing the Products

## 1.1 Introduction

### Terms, Basic Principles

#### Parameters

Communication between master and drive takes place, with a few exceptions, by means of parameters.

Parameters are used for:

- determining the configuration
- parameterizing the control loop
- triggering and controlling drive functions and commands
- transmitting command values and actual values (according to requirements, cyclically or acyclically)

All operating data are mapped to parameters!

The operating data stored in parameters can be identified by means of the IDN. They can be read and transferred, if required. The user write access to parameters depends on the properties of the respective parameter and the current communication phase. Specific parameter values (operating data) are checked for validity by the drive firmware.

#### Data Storage and Parameter Handling

##### Data Memory

Several non-volatile data memories are available in an IndraDrive device:

- in the controller
- in the motor encoder (depending on motor type)

In addition, a volatile data memory (working memory) is available in the controller.

##### Condition As Supplied

Condition as supplied of the Rexroth drive components:

- The controller memory contains the drive firmware and the controller-specific parameter values.
- The motor encoder memory contains the encoder-specific and, depending on the motor type, the motor-specific parameter values.

##### Storing the Application-Specific Parameter Values

The application-specific parameter values are stored in the controller. Due to the limited number of writing cycles of non-volatile storage media, application-specific parameter values can be stored in the working memory (volatile memory), too.

##### Saving Parameter Values

Saving application-specific parameter values is required in the following cases:

- after initial commissioning of the machine axis or the motor
- before replacing the controller for servicing (if possible)

Application-specific parameter values can be saved via:

- "IndraWorks D" commissioning tool → saving the parameter values on external data carrier
- control master → saving the parameter values on master-side data carrier
- comfort control panel

**Parameter IDN Lists** The drive supports master-side saving of parameter values by listing parameter identification numbers (IDNs). Using these lists guarantees complete storage of the application-specific parameter values. It is also possible to determine IDN lists defined by the customer.

**Loading Parameter Values** Loading parameter values is required in the following cases:

- initial commissioning of the motor (loading basic parameter values and motor-specific parameter values)
- serial commissioning of machine axes at series machines (loading the values saved after initial commissioning)
- reestablishing a defined original status (repeated loading of the values saved after initial commissioning)
- replacing the controller for servicing (loading the current parameter values saved before servicing)
- Possibilities of loading parameter values to the controller:
  - motor encoder data memory → loading the parameter values by command or via the control panel during initial motor commissioning
  - "IndraWorks D" commissioning tool → loading the parameter values from external data carrier
  - control master → loading the parameter values from master-side data carrier

**Checksum of Parameter Values** By means of checksum comparison, the control master can determine whether the values of the application-specific parameter values currently active in the drive correspond to the values saved on the master side.

## Password

IndraDrive controllers provide the possibility to protect parameter values against accidental or unauthorized change by means of a password. With regard to write protection, there are 3 groups of parameters that can be written:

- Parameters that are write-protected as a standard, such as motor parameters, hardware code parameters, encoder parameters, error memory etc. ("administration parameters"). The values of these parameters guarantee correct function and performance of the drive.
- Parameters the customer can combine in groups and protect them with a so-called customer password. This allows protecting parameter values, that are used for adjusting the drive to the axis, after having determined them.
- All other parameters that can be written and are not contained in the above-mentioned groups. They are not write-protected.

**Kinds of Passwords** The drive firmware allows activating and deactivating the write protection for parameter values by means of three hierarchically different passwords:

- **Customer password**

The parameter values of a parameter group combined by the customer can be protected.

- **Control password**

Parameters protected by a customer password can be written; "administration parameters" remain write-protected.

- **Master password**

All parameters that can be written, including "administration parameters" and parameters protected by a customer password, can be changed.



## Commands

Commands are used to activate and control complex functions or monitoring features in the drive. The higher-level master can start, interrupt or clear commands.

Each command is assigned to a parameter by means of which the execution of the command can be controlled. During the execution of the command the display of the control panel reads "Cx", "C" representing the diagnostic command message and "x" representing the number of the command.

---

**Note:** Each command that was started must be actively cleared again.

---

All commands available in the drive are stored in the **S-0-0025, IDN-list of all procedure commands** parameter.

### Kinds of Commands

There are 3 different kinds of commands:

- **Drive control commands**
  - can cause automatic drive motion,
  - can be started only when drive enable has been set,
  - deactivate the active operating mode during its execution.
- **Monitoring commands**
  - activate or deactivate monitors or functions in the drive.
- **Administration commands**
  - carry out administration tasks,
  - cannot be interrupted.

See also "Command Processing" in chapter "Master Communication"

## Operating Modes

The selection of operating modes defines which command values will be processed in which way, in order to lead to the desired drive motion. The operating mode does not determine how these command values are transmitted from the master to the slave.

One of the four or eight (for SERCOS) operating modes defined in parameters is always active when the following conditions have been fulfilled:

- control section and power section are ready for operation
- drive enable signal sees a positive edge
- drive follows command value
- "Drive Halt" function has not been activated
- no drive control command is active
- no error reaction is carried out

The display of the control panel reads "AF" when an operating mode was activated.

---

**Note:** All implemented operating modes are stored in the **S-0-0292, List of all operating modes** parameter.

---

See also chapter "Operating Modes"

## Warnings

Depending on the active operating mode and the parameter settings, many monitoring functions are carried out. If a status is detected that still allows correct operation but in case this status persists will cause an error to occur and therefore cause the drive to be automatically switched off, the drive firmware generates a warning message.

---

**Note:** Warnings do not cause automatic shutdown (exception: fatal warning).

---

### Warning Classes

Warnings are classified in different warning classes which determine whether the drive, when the warning is generated, carries out an automatic reaction or not.

---

**Note:** The warning class can be recognized by the diagnostic message.

---

The following classes of warnings are distinguished:

- **without** drive reaction → diagn. message no. **E2xxx, E3xxx, E4xxx**
- **with** drive reaction → diagn. message no. **E8xxx**

---

**Note:** Warnings cannot be cleared. They persist until the condition that activated the warning is no longer fulfilled.

---

## Errors

Depending on the active operating mode and the parameter settings, many monitoring functions are carried out. If a status is detected that affects or prevents correct operation the drive firmware generates an error message.

### Error Classes

Errors are classified in different error classes. There are 6 error classes with different drive error reactions.

---

**Note:** The error class can be recognized by the diagnostic message number.

---

Diagnostic message number	Error class
F2xxx	non-fatal error
F3xxx	non-fatal safety technology error
F4xxx	interface error
F6xxx	travel range error
F7xxx	safety technology error
F8xxx	fatal error
F9xxx	fatal system error
E-xxxx	fatal system error "processor exception"

Fig. 1-1: Overview of error classes

---

**Note:** Apart from the mentioned error classes that can occur during operation, errors can occur when the devices are booted and

during firmware download. These errors are not displayed at the control panel with a diagnostic message number of the "Fxxx" pattern, but with a short text. Boot errors and firmware download errors are separately described in the documentation "Troubleshooting Guide" (diagnostic message description).

#### Error Reactions of the Drive

If the drive controller is in control and an error status is detected, the execution of a drive error reaction is automatically started. The diagnostic message number "Fxxx" flashes on the display of the control panel.

The drive reaction in the case of interface errors and non-fatal errors is determined in parameter **P-0-0119, Best possible deceleration**. At the end of each error reaction, the drive is torque-free.

See also "Error Reactions" in chapter "Drive Functions"

#### Clearing Error Messages

Error messages are not cleared automatically but by the following action:

- activating the **S-0-0099, C0500 Reset class 1 diagnostics** command
- or -
- actuating the "Esc" button on the control panel

If the error status persists the error message is immediately generated again.

#### Clearing Error Messages when Drive Enable Was Set

If a drive error occurs while operating with drive enable having been set, the drive carries out an error reaction. The drive automatically deactivates itself at the end of each error reaction; in other words, the output stage is switched off and the drive switches from an energized to a de-energized state.

To reactivate the drive:

- clear the error message and
- input a positive edge for drive enable again.

#### Error Memory

The diagnostic message numbers of occurring errors are written to an error memory. This memory contains the diagnostic message numbers of the last 50 errors that occurred and the time when they occurred. Errors caused by a shutdown of the control voltage (e.g. **F8070 +24Volt DC error**) are not stored in the error memory.

The diagnostic message numbers in the error memory are mapped to the **P-0-0192, Diagnostic numbers of error memory** parameter and can be displayed by means of the control panel. By means of the "IndraWorks D" commissioning tool it is possible to display the diagnostic message numbers and the respective times at which the errors occurred.

## 1.2 Rexroth IndraDrive Hardware Platform

### Drive Controllers

#### Overview

The drive controller consists of two essential parts:

- power section
- control section

**Power section** The power section incorporates the control section and has the following connections:

- mains voltage connection (at supply modules and HCS devices)
- motor connection (with optional motor holding brake and motor temperature monitor)
- 24 V control voltage
- DC bus connection
- module bus connection
- connection for external braking resistor (at HCS devices)

**Control section** The control section is a separate component that is plugged into the power section. The drive controller is supplied complete with factory-installed (possibly configured) control section.

#### Power Sections

##### IndraDrive C

**300 mm Design**

- HCS02.1E-W0012
- HCS02.1E-W0028
- HCS02.1E-W0054
- HCS02.1E-W0070

**400 mm Design**

- HCS03.1E-W0070
- HCS03.1E-W0100
- HCS03.1E-W0150
- HCS03.1E-W0210

#### Control Sections

- BASIC OPENLOOP (single axis; type CSB01.1N-FC-...)
- BASIC PROFIBUS (single axis CSB01.1N-PB-...)

#### Supported Control Section Configurations

The configurable control sections differ with regard to the scope of their configurability. It basically depends on the control section type and the corresponding firmware variant. The following abbreviations are used:

##### Options for master communication:

- **PB** → PROFIBUS-DP
- **FC** → FC Interface

## Motors and Measuring Systems

### Supported Motors

The table below contains an overview of the Rexroth motors which can be operated at IndraDrive controllers.

Housing motors		Kit motors	
synchronous	asynchronous	synchronous	asynchr.
MHD	2AD	MLF (IndraDyn L)	1MB
MKD	ADF	MBS (Standard)	
MKE	MAD (IndraDyn A)	MBSxx2 (IndraDyn H)	
MSK (IndraDyn S)	MAF (IndraDyn A)	MBT (IndraDyn T)	
MAL		LSF	
SF (Bosch)			

Fig. 1-2: Appropriate Rexroth motors for IndraDrive

#### Third party motors

Third party motors must meet the specified requirements.

#### Motor Encoders and External Optional Encoders

### Supported Measuring Systems

In addition to the encoders integrated in the Rexroth motors, the IndraDrive firmware can evaluate the following measuring systems as motor encoders or as external optional control encoders:

- Bosch Rexroth GDS or GDM encoders (single-turn or multi-turn type)
- resolvers according to Rexroth signal specification (single-turn or multi-turn type)
- encoders with sine signals and EnDat2.1 interface (1 V<sub>pp</sub>)
- encoders with sine signals (1 V<sub>pp</sub>)
- encoders with square-wave signals (TTL)
- Hall sensor box and encoder with sine signals (1 V<sub>pp</sub>)
- Hall sensor box and encoder with square-wave signals (TTL)
- encoders with sine signals and HIPERFACE interface (1 V<sub>pp</sub>)

#### Measuring Encoders

For measuring purposes the firmware can evaluate the following measuring systems (measuring encoders, no control encoders):

- Bosch Rexroth GDS or GDM encoders (single-turn or multi-turn type)
- encoders with sine signals and EnDat2.1 interface (1 V<sub>pp</sub>)
- encoders with sine signals (1 V<sub>pp</sub>)
- encoders with square-wave signals (TTL)
- encoders with sine signals and HIPERFACE interface (1 V<sub>pp</sub>)
- motor encoders of MSK, MHD, 2AD, ADF, MAD, MAF motors
- SSI encoders

---

**Note:** Resolvers cannot be evaluated as measuring encoders!

---

# Master Communication

## PROFIBUS Interface

- General Features**
- cyclic data exchange of command and actual value (max. 32 byte each direction; min. cycle time of 500 µs)
  - parameter channel for parameterization and diagnosing via field bus
  - safe process data channel (PROFIsafe), optional
  - free configuration of telegram contents possible (many cyclic configurable parameter IDN)

## 1.3 Rexroth IndraDrive Firmware Platform

### Type Code

**Structure of the Firmware Type Designation** The individual functional packages can be combined to form the following firmware types that can be ordered:

	IndraDrive-Firmware	Base package of variant ... (depending on control section)	Version	Release	Language	Open-/closed-loop	Alternative expansion packages	Additive expansion packages
<b>Basic single-axis</b>	FWA-INDRV*	-MPB-	04	VRS-	D5-	x-	xxx-	xx

Fig. 1-3: Basic structure of the firmware type designation

**Firmware Types That Can Be Ordered** The following overview shows the available scope of functions of the respective base package:

Control section	Firmware range	Base package	Version	Release	Language	Open/closed-loop	Alternative functional packages	IndraMotion MLD-S	Scope of functional packages
<b>Basic single-axis</b>	FWA-INDRV*-	MPB-	04	VRS-	D5-	0-	NNN	-NN	base package (open-loop)
	FWA-INDRV*-	MPB-	04	VRS-	D5-	0-	SNC	-NN	base package (open-loop) + synchronization
	FWA-INDRV*-	MPB-	04	VRS-	D5-	0-	MSP	-NN	base package (open-loop) + main spindle
	FWA-INDRV*-	MPB-	04	VRS-	D5-	0-	ALL	-NN	base package (open-loop) + all altern. functions
	FWA-INDRV*-	MPB-	04	VRS-	D5-	0-	NNN	-ML	base package (open-loop) + IndraMotion MLD-S
	FWA-INDRV*-	MPB-	04	VRS-	D5-	0-	***	-ML	base package (open-loop) + *** + IndraMotion MLD-S
	FWA-INDRV*-	MPB-	04	VRS-	D5-	1-	NNN	-NN	base package (closed-loop)
	FWA-INDRV*-	MPB-	04	VRS-	D5-	1-	SRV	-NN	base package (closed-loop) + servo function
	FWA-INDRV*-	MPB-	04	VRS-	D5-	1-	SNC	-NN	base package (closed-loop) + synchronization
	FWA-INDRV*-	MPB-	04	VRS-	D5-	1-	MSP	-NN	base package (closed-loop) + main spindle
	FWA-INDRV*-	MPB-	04	VRS-	D5-	1-	ALL	-NN	base package (closed-loop) + all altern. functions
	FWA-INDRV*-	MPB-	04	VRS-	D5-	1-	NNN	-ML	base package (closed-loop) + IndraMotion MLD-S
	FWA-INDRV*-	MPB-	04	VRS-	D5-	1-	***	-ML	base package (closed-loop) + *** + IndraMotion MLD-S

\*\*\* selected option "alternative functional packages" according to availability

Fig. 1-4: Overview of firmware types and functional packages they are containing

## Functions Overview

### Supported Operating Modes

The drive firmware supports the following operating modes:

- torque/force control
- velocity control
- position control with cyclic command value input
- drive-internal interpolation
- drive-controlled positioning
- positioning block mode
- synchronization modes:
  - velocity synchronization with real/virtual master axis
  - phase synchronization with real/virtual master axis
  - electronic cam shaft with real/virtual master axis
  - electronic motion profile with real/virtual master axis

---

**Note:** The operating modes supported by the firmware depend on the hardware and firmware and are contained in parameter **S-0-0292, List of all operating modes.**

---

### Drive Functions

These are the most important drive functions of the MPX-04 firmware:

- Drive Halt
- establishing the position data reference
  - drive-controlled homing
  - setting absolute measuring
  - shifting the position data reference
- drive error reactions
  - best possible deceleration
  - package reaction on error
  - NC reaction on error
- E-Stop function
- compensation functions/corrections
  - friction torque compensation
  - encoder correction
  - axis error correction
  - quadrant error correction
- spindle positioning
- drive-integrated command value generator
- parameter set switching
- probe function
- encoder emulation
- programmable position switch
- drive-integrated PLC (IndraMotion MLD-S)
- integrated safety technology

- monitoring functions
- limitations that can be parameterized
- output of control signals
- numerous diagnostic possibilities
  - drive-internal generation of diagnostic messages
  - analog output
  - status displays, status classes
  - oscilloscope function
  - monitoring function
  - patch function
  - code of optional card
  - parameter value check
  - operating hours counter, logbook function, error memory

### Performance Data

**Overview** For the control performance of the IndraDrive range we basically distinguish three levels with regard to the clock rates (cycle times):

- **Basic** performance  
 → standard control performance by medium internal clock rates for the control loops and the signal processing of inputs/outputs or drive-integrated PLC (IndraMotion MLD-S)

In this documentation the clock rate data refer to the following characteristic values:

- current loop clock  $T_{A\_current}$
- velocity loop clock  $T_{A\_velocity}$
- position loop clock  $T_{A\_position}$
- cycle time of PLC (IndraMotion MLD-S)  $T_{MLD-S}$
- cycle time of master communication  $T_{MastCom}$

The table below contains an overview of the clock rates depending on the respective control performance. The detailed assignment of the clock rate to control section design, performance level and parameter setting is contained in the table in section "Control Section Design and Performance" (see below).

Performance	$T_{A\_Strom}$	$T_{A\_Geschw}$	$T_{A\_Lage}$	$T_{MLD-S}$	$T_{FKM}$
Basic	62,5/83,3/125 $\mu$ s	250 $\mu$ s	500 $\mu$ s	2000 $\mu$ s	500/1000 $\mu$ s

Fig. 1-5: Clock rates (depending on the available performance)

Control section type/ firmware	Functional packages	Perform. level	$T_{A\_current}$	$T_{A\_velocity}$	$T_{A\_posit.}$	$T_{MLD-S}$	$T_{MastCom}$	Switching frequency <sup>1)</sup>	P-0-0556	
									bit 2	bit 5
CSB01.1/MPB	all, except for "synchronization" and "IndraMotion"	Basic	125 $\mu$ s	250 $\mu$ s	500 $\mu$ s	--	1000 $\mu$ s	4000 Hz	0	0
		Basic	125 $\mu$ s	250 $\mu$ s	500 $\mu$ s	--	1000 $\mu$ s	8000 Hz	0	0

<sup>1)</sup>: can be set via P-0-0001  
 P-0-0556: config word of axis controller

Fig. 1-6: Performance depending on the control section design



**Selecting Performance via  
Parameter P-0-0556**

For certain applications it is necessary to use the same clock rates in all axes so that the slowest drive sets the clock. It is therefore possible to specifically reduce the performance via bit 2 and bit 5 of parameter **P-0-0556, Config word of axis controller**.

- For **BASIC control sections** it is possible to select the performance levels "Basic" or "Economy" via bit 5 of P-0-0556.

See also Parameter Description "P-0-0556, Config word of axis controller"

---

**Note:** The effective clock rates of the active performance level are contained in the table "Performance depending on the control section design" in section "Control Section Design and Performance" (see above).

---

**Restricted Performance with  
Certain Functional Packages**

If you use extensive and complex functions, the internal clock rates for **BASIC control sections** (CSB with firmware MPB and CDB with firmware MPD) are automatically reduced. This applies to the use of the following functional packages:

- drive-integrated PLC "IndraMotion MLD-S" (functional package "ML")
- expansion package "synchronization" (functional package "SNC")

If you use one of these functional packages for BASIC control sections, the clock rates (position loop, velocity loop) are reduced to the lowest performance level "Economy!"

## 1.4 Rexroth IndraDyn Motors

### Housing Motors

#### Type Code S

**Example** MSK030B-0900-NN-S1-UG0-NNNN

Product	Motor size	Motor length	Windings code	Housing design	Encoder	Electrical Connection	Shaft	Holding brake	Other design
MSK	030	B	0900	NN	S1	U	G	0	NNNN

Fig. 1-7: Basic structure of type code

#### Type Code IndraDyn A

**Example** MAF130B-0150-FQ-M0-LH0-05-N1

Product	Motor size	Motor length	Windings code	Cooling mode	Encoder	Electrical Connection	Shaft	Holding brake	Mounting style	Bearings	Vibration severity grade
MAF	130	B	0150	FQ	M0	L	H	0	05	N	1

Fig. 1-8: Basic structure of type code

### Kit Motors

#### Type Code IndraDyn L

**Example** MLP100A-0120-FS-N0CN-NNNN

Product	Motor size	Motor length	Windings code	Cooling mode	Encapsulation	Encoder	Electrical Connection	Other design
MLP	100	A	0120	F	S	N0	CN	NNNN

Fig. 1-9: Basic structure of type code

### Type Code IndraDyn H

**Example 1** MRS102B-1N-0046-NNNN

Product	Motor size	Motor length	Mounting style	Internal diameter of the rotor	Other design
MRS	102	B	1N	0046	NNNN

Fig. 1-10: Basic structure of type code

**Example 2** MSS102B-0800-FA-N0CN-NNNN

Product	Motor size	Motor length	Windings code	Cooling mode	Cooling connector	Encoder	Electrical connection	Other design
MSS	102	B	0800	F	A	N0	CN	NNNN

Fig. 1-11: Basic structure of type code

## 1.5 Third-Party Motors at IndraDrive Controllers

### General Information on Third-Party Motors

#### Why Use Third-Party Motors at IndraDrive?

Today machine axes are mainly moved with electric drives. Motors of standard design are used in most cases as this is the most cost-efficient solution.

#### Special Requirements

Due to special requirements at machine axes, constructional or safety-related aspects, it may be necessary for the machine manufacturer to use a motor construction diverging from the standard.

#### Undeliverable Motor Design

For these cases there is the demand on the drive supplier to realize, apart from the deliverable standard drive consisting of (standard) motor, controller, cable and, if required, machine control unit, drives with motors that are not included in his own product range due to the special design.

#### Check Before Using Third-Party Motors

At Rexroth controllers of the IndraDrive range it is also possible to use third-party motors. For this purpose, check whether the third-party motor complies with the requirements of use.

#### Which are the Important Directives?

#### Additional Aspects to be Observed

According to the legal requirements

- of the EU directives EMC89/336/EEC and
- the German EMC laws

installations and machines have to be designed and built according to the present state of standardization. In order to comply with the machine directives regarding "electromagnetic compatibility (EMC)", a conformity test of the drive system (motor with controller and connection design) has

to be carried out. The test of the drive system and compliance with the directives have to be guaranteed by the machine manufacturer.

### Third-Party Motors to be Controlled

**Motor Types** The following motor types can be controlled:

- asynchronous motors, rotary
- asynchronous motors, linear
- synchronous motors, rotary
- synchronous motors, linear

These motors can be operated within the scope of the technical data of the selected IndraDrive controller. If motors have been provided with a holding brake, it should be controlled via the controller. Make sure that the relevant technical data of the motor holding brake are complying with those of the holding brake output.

---

**Note:** For third-party motors Bosch Rexroth, as a matter of principle, does not assume the guarantee for the power data at the motor shaft!

---

### Synchronous Motors

In the case of synchronous motors, the commutation offset has to be set during commissioning. The drive firmware provides several methods for determining this offset so that it is possible to determine the value for different motor characteristics.

---

**Note:** Observe the restrictions in conjunction with the commutation offset determination when using synchronous motors!  
See Functional Description of firmware "Motor Control: Commutation Setting" in chapter "Drive Control"

---

Possibly available reluctance property cannot be used for synchronous third-party motors! For third-party motors it is impossible to determine fail-safe motor parameter values for using the reluctance property; the respective bit of **P-0-4014, Type of construction of motor** therefore mustn't be set!

## Requirements on Third-Party Motors

For successful and fail-safe use of a third-party motor check

- whether the third-party motor to be controlled satisfies the voltage loads,
- which controller, including supply, is suitable due to the motor power to be delivered,
- whether the third-party motor has the required minimum inductance,
- whether the motor can be protected against inadmissible temperature rise in the case of overload (temperature evaluation),
- whether the mounted position measuring system can be evaluated by the controller or which position measuring system can be selected for kit motors.

### Voltage Load of the Third-Party Motor

The voltage load of the insulation system of a motor occurring in practical application is mainly influenced by the following characteristics:

- The output variables of the drive controller which is used (feed the transmission distance).

- The cable parameters depending on cable design and length (determine the properties of the transmission distance, such as the attenuation).
- The motor design regarding capacitive and inductive properties (form the end of the transmission distance).

As a result of the variables, the insulation system of the third-party motor, as regards voltage, is loaded by the values

- peak voltage  $U_{pp}$  and
- voltage change  $dv/dt$ .

The occurring peak voltages at the motor are caused by reflections in the motor cable. The insulation of the motor is thereby loaded with other peak voltages and voltage changes than the ones occurring at the output of the power section.

---

**Note:** Determine the occurring voltage load at the terminals of the third-party motor in the application with all involved components.

---

**Use of Voltage-Reducing Components, Motor Filter HMF**

Use voltage-reducing components (e.g. **motor filter HMF**), if one of the following criteria applies:

- allowed voltage change ( $dv/dt$ ) of third-party motor **smaller than 5 kV/μs**
- allowed peak voltage (crest value) of third-party motor between phase-phase and phase-housing **smaller than 1500 V**
- motor cable length **smaller than 25 m**
- mains voltage **greater than AC440V**

---

**Note:** Apart from the nominal current  $I_N$ , especially take the maximum allowed switching frequency of the power output stage ( $f_s$ ) into account with which the motor filter HMF may be operated.

Verify the success of the voltage-reducing measure.

---

**Minimum Inductance of Third-Party Motor**

Depending on the controller used, the motor has to have a minimum value for inductance. The actually available inductance of a motor can be measured directly between two motor terminals by means of an inductance measuring bridge. The measurement has to be made for a complete motor wired for normal operation but not yet connected. During the measurement one motor terminal remains open!

For asynchronous motors the measured value can only be used if the rotor doesn't have closed slots!

Controller type	Minimum required motor inductance
HCS with 3*AC230V	$L_{U-V} = 60 * 4 / (\sqrt{2} * I_{Typ} * f_s)$ (in mH)
HMS, HMD at HMV (3*AC400V) HMS, HMD at HCS (3*AC400V)	$L_{U-V} = 80 * 4 / (\sqrt{2} * I_{Typ} * f_s)$ (in mH)
HMS, HMD at HMV (3*AC480V) HMS, HMD at HCS (3*AC480V)	$L_{U-V} = 116 * 4 / (\sqrt{2} * I_{Typ} * f_s)$ (in mH)

$I_{Typ}$ : maximum controller current acc. to type code (rms value)  
 $f_s$ : desired switching frequency in kHz

Fig. 1-12: Minimum inductances depending on controller data, supply units and supply voltage

Use a three-phase choke in the motor feed wire, if the inductance of the third-party motor is smaller than indicated in the table above. This choke has to increase the inductance that can be measured between two motor terminals to the minimum value.

**Note:** When the inductance is measured, different inductance values can be determined at different rotor positions within one pole pair distance of the motor. The average value is relevant for the check of the minimum value.

Correct values can only be determined when the motor is **in standstill!**

Available third-party motor	Planned third-party motor
 <p data-bbox="582 840 981 947"> <math>L_{Dr} = 0,5 * (L_{U-Vmin} - L_{U-V})</math>            (inductance measurement with 1 kHz)            mounting of 3x <math>L_{Dr}</math> (three-phase choke)         </p>	<p data-bbox="1018 622 1434 784">Calculating the leakage inductance (asynchronous motor) or inductance (synchronous motor) of the third-party motor by means of the single-phase equivalent circuit diagram (manufacturer's specification!).</p> <p data-bbox="1018 795 1340 851">Determine choke by means of calculation, if necessary.</p> <p data-bbox="1018 862 1426 896">It is recommended to contact Rexroth!</p>
<p data-bbox="579 958 877 985">Requirements on the choke:</p> <ul data-bbox="579 990 1417 1249" style="list-style-type: none"> <li>- <math>I_{n\_Dr} \geq I_{n\_Mot}</math> The rated current of the choke has to be greater than or equal to the rated motor current.</li> <li>- Depending on the maximum speed, the choke is loaded with the respective output frequency and the PWM frequency of the controller.</li> <li>- The insulation class has to correspond at least to that of the motor or has to be dimensioned for higher temperatures.</li> <li>- The voltage load of the choke depends on the controller used.</li> </ul>	

Fig. 1-13: Data for possibly required choke

### Temperature Evaluation of Third-Party Motor

Only operate such motors with incorporated temperature sensor at IndraDrive controllers so that the motor can be thermally monitored by the controller and protected against destruction by too high temperature rise (see P-0-0512, Temperature sensor).

When, in exceptional cases, you want to operate third-party motors without temperature sensor at IndraDrive controllers, you must determine the thermal time constants of motor housing (P-0-4035) and motor winding (P-0-4034, P-0-4037). The firmware-internal motor temperature model can thereby reflect the cooling situation of the motor correctly.

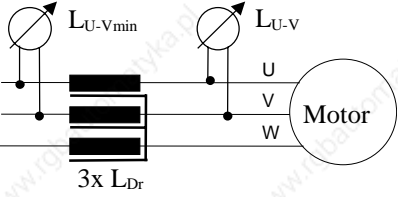
**Note:** In case the motor housing or blower is dirty, this worsens the cooling situation of the motor and protection against thermal overload is therefore insufficient!

## Requirements on the Encoder of the Third-Party Motor

### Motor Encoder of Asynchronous Third-Party Motor

Asynchronous motors can also be controlled by IndraDrive controllers in "open-loop" operation (without motor encoder). In "closed-loop" operation (with motor encoder) a relative measuring system is sufficient for asynchronous motors.

### Motor Encoder of Synchronous Third-Party Motor

For fail-safe drives with synchronous third-party motors at IndraDrive controllers the following possible combinations or restrictions have to be taken into account when selecting the measuring system:

Drive range	Motor measuring system	Synchronous third-party motor
IndraDrive	absolute	+
	relative	o

+ ... advantageous combination

o ... Combination is possible (restrictions specific to application), commissioning may be more complicated!

Fig. 1-14: Possible combinations of synchronous third-party motor and motor measuring system

**Note:** The control section integrated in the controller can evaluate measuring systems as a motor encoder if they are contained in **P-0-0074, Encoder type 1 (motor encoder)** (see also Project Planning Manual of the IndraDrive control sections).

For information on absolute and relative measuring systems see section "Measuring Systems" of Functional Description of firmware!

## Notes on Selection and Commissioning

### Selecting the Controller as Regards Continuous Current

The controller required for the respective motor and the supply unit are determined by comparing the motor data to the data of these devices (see documentation for HMS/HMD and HMV or HCS).

**Note:** The continuous current of the controller should be greater than that of the motor, the continuous power of the supply must be greater than the sum of all average powers of the axes of the drive system!

### Selecting the Connection Technique

The available power and encoder cables are described in the documentation "Connection Cables; Selection Data" (DOK-CONNEX-CABLE\*STAND-AU...).

### Notes on Commissioning

**Note:** For further information, notes on commissioning and supporting documents (e.g. forms for entering the required data) see Functional Description of firmware.

## 1.6 Approval, Listing

### Conformities

#### Declaration of Conformity

For Rexroth IndraDrive components there are declarations of conformity available. These declarations confirm that the components are designed according to valid EC directives. If required, you can ask your sales representative for these declarations.

#### Low-Voltage Directive

The Rexroth products of a drive system mentioned in this documentation comply with the requirements of the EC Directive 73/23/EEC (Low-Voltage Directive), annex III B.

#### EMC Directive

The Rexroth products of a drive system mentioned in this documentation comply with the requirements of the EC Directive 89/336/EEC (EMC Directive) with the amendments 91/263/EEC and 93/68/EEC.

CE Label



Fig. 1-15: CE label

### C-UL-US-Listing

Devices approved by the UL agency carry the following label:



Fig. 1-16: C-UL-US label



Motors approved by the UL agency carry the following label:



Fig. 1-17: C-UR-US label

**C-UL-US Listed Components**

Product	Component	File Number
HMS01.1N-	W0020, W0036, W0054, W0070, W0150, W0210	E 134201
HMS02.1N-	W0028, W0054	E 134201
HMD01.1N-	W0012, W0020, W0036	E 134201
HCS02.1E-	W0012, W0028, W0054, W0070	E 134201
HCS03.1E-	W0070, W0100, W0150, W0210	Manufacturer REFU E254781
HMV01.1E-	W0030-A-07, W0075-A-07, W0120-A-07	E 134201
HMV01.1R-	W0018-A-07, W0045-A-07, W0065-A-07	E 134201
HMV02.1R-	W0015	E 134201
HLB01.1C-	01K0-N06R0-A-007-NNN	E 134201
HLB01.1D-	02K0-N03R4-A-007-NNN	E 134201
HLC01.1C-	01M0-A-007, 02M4-A-007	E 134201
HLC01.1D-	05M0-A-007	E 134201
NFD03.1-	-007, -016, -030, -055, -075, -130, -180	E 172117 and CSA Cert. 1038841Master Contr. 171321
HNL01.1-	.....	CSA Cert. 1492099Master Contr. 222887
HNF01.1	In preparation	E 134201
HNK01.1	In preparation	E 134201
HLR01.1	In preparation	E 134201

Fig 1-18: C-UL-US listed Rexroth IndraDrive components

**Note:** The components are listed by the file number of „Underwriters Laboratories Inc.®" (UL). The documented evidence of listing can be seen in the internet: <http://www.ul.com>, "Certifications", enter file number or "Company name: Rexroth."  
 The control sections are included in the listing of the power sections. The control sections are not listed separately.



## 2 Important Directions for Use

### 2.1 Appropriate Use

#### Introduction

Rexroth products represent state-of-the-art developments and manufacturing. They are tested prior to delivery to ensure operating safety and reliability.

The products may only be used in the manner that is defined as appropriate. If they are used in an inappropriate manner, then situations can develop that may lead to property damage or injury to personnel.

---

**Note:** Rexroth as manufacturer is not liable for any damages resulting from inappropriate use. In such cases, the guarantee and the right to payment of damages resulting from inappropriate use are forfeited. The user alone carries all responsibility of the risks.

---

Before using Rexroth products, make sure that all the pre-requisites for an appropriate use of the products are satisfied:

- Personnel that in any way, shape or form uses our products must first read and understand the relevant safety instructions and be familiar with appropriate use.
- If the products take the form of hardware, then they must remain in their original state, in other words, no structural changes are permitted. It is not permitted to decompile software products or alter source codes.
- Do not mount damaged or faulty products or use them in operation.
- Make sure that the products have been installed in the manner described in the relevant documentation.

## Areas of Use and Application

Drive controllers made by Bosch Rexroth are designed to control electrical motors and monitor their operation.

Control and monitoring of the motors may require additional sensors and actors.

---

**Note:** The drive controllers may only be used with the accessories and parts specified in this document. If a component has not been specifically named, then it may not be either mounted or connected. The same applies to cables and lines.

Operation is only permitted in the specified configurations and combinations of components using the software and firmware as specified in the relevant Functional Descriptions.

---

Every drive controller has to be programmed before commissioning, making it possible for the motor to execute the specific functions of an application.

The drive controllers have been developed for use in single- and multi-axis drive and control tasks.

To ensure an application-specific use, the drive controllers are available with different drive power and different interfaces.

Typical applications of the drive controllers include:

- handling and mounting systems,
- packaging and food machines,
- printing and paper processing machines and
- machine tools.

The drive controllers may only be operated under the assembly and installation conditions described in this documentation, in the specified position of normal use and under the ambient conditions as described (temperature, degree of protection, humidity, EMC, etc.).

## 2.2 Inappropriate Use

Using the drive controllers outside of the operating conditions described in this documentation and outside of the indicated technical data and specifications is defined as "inappropriate use".

Drive controllers must not be used, if

- ... they are subject to operating conditions that do not meet the specified ambient conditions. This includes, for example, operation under water, under extreme temperature fluctuations or extremely high maximum temperatures.
- Furthermore, the drive controllers must not be used in applications which have not been expressly authorized by Rexroth.
- Please carefully follow the specifications outlined in the general Safety Instructions!

## 3 Safety Instructions for Electric Drives and Controls

### 3.1 General Information

#### Using the Safety Instructions and Passing them on to Others

Do not attempt to install or commission this device without first reading all documentation provided with the product. Read and understand these safety instructions and all user documentation prior to working with the device. If you do not have the user documentation for the device, contact your responsible Bosch Rexroth sales representative. Ask for these documents to be sent immediately to the person or persons responsible for the safe operation of the device.

If the device is resold, rented and/or passed on to others in any other form, then these safety instructions must be delivered with the device.



**WARNING**

**Improper use of these devices, failure to follow the safety instructions in this document or tampering with the product, including disabling of safety devices, may result in material damage, bodily harm, electric shock or even death!**

#### Instructions for Use

Read these instructions before the initial startup of the equipment in order to eliminate the risk of bodily harm or material damage. Follow these safety instructions at all times.

- Bosch Rexroth AG is not liable for damages resulting from failure to observe the warnings provided in this documentation.
- Read the operating, maintenance and safety instructions in your language before starting up the machine. If you find that you cannot completely understand the documentation for your product, please ask your supplier to clarify.
- Proper and correct transport, storage, assembly and installation as well as care in operation and maintenance are prerequisites for optimal and safe operation of this device.
- Only assign trained and qualified persons to work with electrical installations:

Only persons who are trained and qualified for the use and operation of the device may work on this device or within its proximity. The persons are qualified if they have sufficient knowledge of the assembly, installation and operation of the equipment as well as an understanding of all warnings and precautionary measures noted in these instructions.

Furthermore, they must be trained, instructed and qualified to switch electrical circuits and devices on and off in accordance with technical safety regulations, to ground them and to mark them according to the requirements of safe work practices. They must have adequate safety equipment and be trained in first aid.

- Only use spare parts and accessories approved by the manufacturer.
- Follow all safety regulations and requirements for the specific application as practiced in the country of use.

- The devices have been designed for installation in industrial machinery.
- The ambient conditions given in the product documentation must be observed.
- Only use safety-relevant applications that are clearly and explicitly approved in the Project Planning Manual. If this is not the case, they are excluded.  
Safety-relevant are all such applications which can cause danger to persons and material damage.
- The information given in the documentation of the product with regard to the use of the delivered components contains only examples of applications and suggestions.

The machine and installation manufacturer must

make sure that the delivered components are suited for his individual application and check the information given in this documentation with regard to the use of the components,

make sure that his application complies with the applicable safety regulations and standards and carry out the required measures, modifications and complements.

- Startup of the delivered components is only permitted once it is sure that the machine or installation in which they are installed complies with the national regulations, safety specifications and standards of the application.
- Operation is only permitted if the national EMC regulations for the application are met.
- The instructions for installation in accordance with EMC requirements can be found in the documentation "EMC in Drive and Control Systems".
- The machine or installation manufacturer is responsible for compliance with the limiting values as prescribed in the national regulations.
- Technical data, connections and operational conditions are specified in the product documentation and must be followed at all times.

## Explanation of Warning Symbols and Degrees of Hazard Seriousness

The safety instructions describe the following degrees of hazard seriousness. The degree of hazard seriousness informs about the consequences resulting from non-compliance with the safety instructions:



Warning symbol with signal word	Degree of hazard seriousness according to ANSI Z 535
 <b>DANGER</b>	Death or severe bodily harm will occur.
 <b>WARNING</b>	Death or severe bodily harm may occur.
 <b>CAUTION</b>	Bodily harm or material damage may occur.

Fig. 3-1: Hazard classification (according to ANSI Z 535)

## Hazards by Improper Use



**DANGER**

**High electric voltage and high working current!  
Risk of death or severe bodily injury by electric shock!**



**DANGER**

**Dangerous movements! Danger to life, severe bodily harm or material damage by unintentional motor movements!**



**WARNING**

**High electric voltage because of incorrect connection! Risk of death or bodily injury by electric shock!**



**WARNING**

**Health hazard for persons with heart pacemakers, metal implants and hearing aids in proximity to electrical equipment!**



**CAUTION**

**Hot surfaces on device housing! Danger of injury! Danger of burns!**



**CAUTION**

**Risk of injury by improper handling! Risk of bodily injury by bruising, shearing, cutting, hitting, or improper handling of pressurized lines!**



**CAUTION**

**Risk of injury by improper handling of batteries!**



## 3.2 Instructions with Regard to Specific Dangers

### Protection Against Contact with Electrical Parts

---

**Note:** This section only concerns devices and drive components with voltages of more than 50 Volt.

---

Contact with parts conducting voltages above 50 Volts can cause personal danger and electric shock. When operating electrical equipment, it is unavoidable that some parts of the devices conduct dangerous voltage.

---



**DANGER**

#### **High electrical voltage! Danger to life, electric shock and severe bodily injury!**

- ⇒ Only those trained and qualified to work with or on electrical equipment are permitted to operate, maintain and repair this equipment.
- ⇒ Follow general construction and safety regulations when working on electrical power installations.
- ⇒ Before switching on the device, the equipment grounding conductor must have been non-detachably connected to all electrical equipment in accordance with the connection diagram.
- ⇒ Do not operate electrical equipment at any time, even for brief measurements or tests, if the equipment grounding conductor is not permanently connected to the mounting points of the components provided for this purpose.
- ⇒ Before working with electrical parts with voltage potentials higher than 50 V, the device must be disconnected from the mains voltage or power supply unit. Provide a safeguard to prevent reconnection.
- ⇒ With electrical drive and filter components, observe the following:
  - Wait 30 minutes after switching off power to allow capacitors to discharge before beginning to work. Measure the voltage on the capacitors before beginning to work to make sure that the equipment is safe to touch.
- ⇒ Never touch the electrical connection points of a component while power is turned on.
- ⇒ Install the covers and guards provided with the equipment properly before switching the device on. Before switching the equipment on, cover and safeguard live parts safely to prevent contact with those parts.
- ⇒ A residual-current-operated circuit-breaker or r.c.d. cannot be used for electric drives! Indirect contact must be prevented by other means, for example, by an overcurrent protective device according to the relevant standards.
- ⇒ Secure built-in devices from direct touching of electrical parts by providing an external housing, for example a control cabinet.

European countries: according to EN 50178/ 1998,

section 5.3.2.3.

USA: See National Electrical Code (NEC), National Electrical Manufacturers' Association (NEMA), as well as local engineering regulations. The operator must observe all the above regulations at any time.

With electrical drive and filter components, observe the following:



**DANGER**

**High housing voltage and large leakage current!  
Risk of death or bodily injury by electric shock!**

- ⇒ Before switching on, the housings of all electrical equipment and motors must be connected or grounded with the equipment grounding conductor to the grounding points. This is also applicable before short tests.
- ⇒ The equipment grounding conductor of the electrical equipment and the units must be non-detachably and permanently connected to the power supply unit at all times. The leakage current is greater than 3.5 mA.
- ⇒ Over the total length, use copper wire of a cross section of a minimum of 10 mm<sup>2</sup> for this equipment grounding connection!
- ⇒ Before start-up, also in trial runs, always attach the equipment grounding conductor or connect with the ground wire. Otherwise, high voltages may occur at the housing causing electric shock.

## Protection Against Electric Shock by Protective Low Voltage (PELV)

All connections and terminals with voltages between 5 and 50 Volt at Rexroth products are protective extra-low voltage systems which are provided with touch guard according to the product standards.



**WARNING**

**High electric voltage by incorrect connection!  
Risk of death or bodily injury by electric shock!**

- ⇒ To all connections and terminals with voltages between 0 and 50 Volt, only devices, electrical components, and conductors may be connected which are equipped with a PELV (Protective Extra-Low Voltage) system.
- ⇒ Connect only voltages and circuits which are safely isolated from dangerous voltages. Safe isolation is achieved for example by isolating transformers, safe optocouplers or battery operation without mains connection.

## Protection Against Dangerous Movements

Dangerous movements can be caused by faulty control of connected motors. Some common examples are:

- improper or wrong wiring of cable connections
- incorrect operation of the equipment components
- wrong input of parameters before operation
- malfunction of sensors, encoders and monitoring devices
- defective components
- software or firmware errors

Dangerous movements can occur immediately after equipment is switched on or even after an unspecified time of trouble-free operation.

The monitoring in the drive components will normally be sufficient to avoid faulty operation in the connected drives. Regarding personal safety, especially the danger of bodily harm and material damage, this alone cannot be relied upon to ensure complete safety. Until the integrated monitoring functions become effective, it must be assumed in any case that faulty drive movements will occur. The extent of faulty drive movements depends upon the type of control and the state of operation.

**DANGER****Dangerous movements! Danger to life, risk of injury, severe bodily harm or material damage!**

⇒ For the above reasons, ensure personal safety by means of qualified and tested higher-level monitoring devices or measures integrated in the installation.

They have to be provided for by the user according to the specific conditions within the installation and a hazard and fault analysis. The safety regulations applicable for the installation have to be taken into consideration. Unintended machine motion or other malfunction is possible if safety devices are disabled, bypassed or not activated.

**To avoid accidents, bodily harm and/or material damage:**

⇒ Keep free and clear of the machine's range of motion and moving parts. Possible measures to prevent people from accidentally entering the machine's range of motion:

- use safety fences
- use safety guards
- use protective coverings
- install light curtains or light barriers

⇒ Fences and coverings must be strong enough to resist maximum possible momentum.

⇒ Mount the emergency stop switch in the immediate reach of the operator. Verify that the emergency stop works before startup. Don't operate the device if the emergency stop is not working.

⇒ Isolate the drive power connection by means of an emergency stop circuit or use a safety related starting lockout to prevent unintentional start.

⇒ Make sure that the drives are brought to a safe standstill before accessing or entering the danger zone.

⇒ Additionally secure vertical axes against falling or dropping after switching off the motor power by, for example:

- mechanically securing the vertical axes,
- adding an external braking/ arrester/ clamping mechanism or
- ensuring sufficient equilibration of the vertical axes.

The standard equipment motor brake or an external brake controlled directly by the drive controller are not sufficient to guarantee personal safety!

- ⇒ Disconnect electrical power to the equipment using a master switch and secure the switch against reconnection for:
    - maintenance and repair work
    - cleaning of equipment
    - long periods of discontinued equipment use
  - ⇒ Prevent the operation of high-frequency, remote control and radio equipment near electronics circuits and supply leads. If the use of such devices cannot be avoided, verify the system and the installation for possible malfunctions in all possible positions of normal use before initial startup. If necessary, perform a special electromagnetic compatibility (EMC) test on the installation.
- 

## Protection Against Magnetic and Electromagnetic Fields During Operation and Mounting

Magnetic and electromagnetic fields generated by current-carrying conductors and permanent magnets in motors represent a serious personal danger to those with heart pacemakers, metal implants and hearing aids.

---



### WARNING

#### Health hazard for persons with heart pacemakers, metal implants and hearing aids in proximity to electrical equipment!

- ⇒ Persons with heart pacemakers and metal implants are not permitted to enter following areas:
    - Areas in which electrical equipment and parts are mounted, being operated or commissioned.
    - Areas in which parts of motors with permanent magnets are being stored, repaired or mounted.
  - ⇒ If it is necessary for somebody with a pacemaker to enter such an area, a doctor must be consulted prior to doing so. The interference immunity of present or future implanted heart pacemakers differs greatly, so that no general rules can be given.
  - ⇒ Those with metal implants or metal pieces, as well as with hearing aids must consult a doctor before they enter the areas described above. Otherwise health hazards may occur.
-

## Protection Against Contact with Hot Parts

---

**CAUTION****Hot surfaces at motor housings, on drive controllers or chokes! Danger of injury! Danger of burns!**

- ⇒ Do not touch surfaces of device housings and chokes in the proximity of heat sources! Danger of burns!
  - ⇒ Do not touch housing surfaces of motors! Danger of burns!
  - ⇒ According to operating conditions, temperatures can be **higher than 60 °C, 140 °F** during or after operation.
  - ⇒ Before accessing motors after having switched them off, let them cool down for a sufficiently long time. Cooling down can require **up to 140 minutes!** Roughly estimated, the time required for cooling down is five times the thermal time constant specified in the Technical Data.
  - ⇒ After switching drive controllers or chokes off, wait 15 minutes to allow them to cool down before touching them.
  - ⇒ Wear safety gloves or do not work at hot surfaces.
  - ⇒ For certain applications, the manufacturer of the end product, machine or installation, according to the respective safety regulations, has to take measures to avoid injuries caused by burns in the end application. These measures can be, for example: warnings, guards (shielding or barrier), technical documentation.
-

## Protection During Handling and Mounting

In unfavorable conditions, handling and assembling certain parts and components in an improper way can cause injuries.



**CAUTION**

### **Risk of injury by improper handling! Bodily injury by bruising, shearing, cutting, hitting!**

- ⇒ Observe the general construction and safety regulations on handling and assembly.
- ⇒ Use suitable devices for assembly and transport.
- ⇒ Avoid jamming and bruising by appropriate measures.
- ⇒ Always use suitable tools. Use special tools if specified.
- ⇒ Use lifting equipment and tools in the correct manner.
- ⇒ If necessary, use suitable protective equipment (for example safety goggles, safety shoes, safety gloves).
- ⇒ Do not stand under hanging loads.
- ⇒ Immediately clean up any spilled liquids because of the danger of skidding.

## Battery Safety

Batteries consist of active chemicals enclosed in a solid housing. Therefore, improper handling can cause injury or damages.



**CAUTION**

### **Risk of injury by improper handling!**

- ⇒ Do not attempt to reactivate low batteries by heating or other methods (risk of explosion and cauterization).
- ⇒ Do not recharge the batteries as this may cause leakage or explosion.
- ⇒ Do not throw batteries into open flames.
- ⇒ Do not dismantle batteries.
- ⇒ Do not damage electrical parts installed in the devices.

**Note:** Environmental protection and disposal! The batteries installed in the product are considered dangerous goods during land, air, and sea transport (risk of explosion) in the sense of the legal regulations. Dispose of used batteries separate from other waste. Observe the local regulations in the country of assembly.

## Protection Against Pressurized Systems

According to the information given in the Project Planning Manuals, motors cooled with liquid and compressed air, as well as drive controllers, can be partially supplied with externally fed, pressurized media, such as compressed air, hydraulics oil, cooling liquids, and cooling lubricating agents. In these cases, improper handling of external supply systems, supply lines, or connections can cause injuries or damages.



**CAUTION**

### **Risk of injury by improper handling of pressurized lines!**

- ⇒ Do not attempt to disconnect, open, or cut pressurized lines (risk of explosion).
- ⇒ Observe the respective manufacturer's operating instructions.
- ⇒ Before dismantling lines, relieve pressure and empty medium.
- ⇒ Use suitable protective equipment (for example safety goggles, safety shoes, safety gloves).
- ⇒ Immediately clean up any spilled liquids from the floor.

**Note:** Environmental protection and disposal! The agents used to operate the product might not be economically friendly. Dispose of ecologically harmful agents separate from other waste. Observe the local regulations in the country of assembly.



# 4 Identification, Transport, Storage, Installation Conditions

## 4.1 Identification

### Type Code

#### Firmware MPB-04

Control section	Firmware range	Base package	Version	Release	Language	Open/closed-loop	Alternative functional packages	IndraMotion MLD-S	Scope of functional packages
Basic single-axis	FWA-INDRV*-	MPB-	04	VRS-	D5-	0-	NNN	-NN	base package (open-loop)
	FWA-INDRV*-	MPB-	04	VRS-	D5-	0-	SNC	-NN	base package (open-loop) + synchronization
	FWA-INDRV*-	MPB-	04	VRS-	D5-	0-	MSP	-NN	base package (open-loop) + main spindle
	FWA-INDRV*-	MPB-	04	VRS-	D5-	0-	ALL	-NN	base package (open-loop) + all altern. functions
	FWA-INDRV*-	MPB-	04	VRS-	D5-	0-	NNN	-ML	base package (open-loop) + IndraMotion MLD-S
	FWA-INDRV*-	MPB-	04	VRS-	D5-	0-	***	-ML	base package (open-loop) + *** + IndraMotion MLD-S
	FWA-INDRV*-	MPB-	04	VRS-	D5-	1-	NNN	-NN	base package (closed-loop)
	FWA-INDRV*-	MPB-	04	VRS-	D5-	1-	SRV	-NN	base package (closed-loop) + servo function
	FWA-INDRV*-	MPB-	04	VRS-	D5-	1-	SNC	-NN	base package (closed-loop) + synchronization
	FWA-INDRV*-	MPB-	04	VRS-	D5-	1-	MSP	-NN	base package (closed-loop) + main spindle
	FWA-INDRV*-	MPB-	04	VRS-	D5-	1-	ALL	-NN	base package (closed-loop) + all altern. functions
	FWA-INDRV*-	MPB-	04	VRS-	D5-	1-	NNN	-ML	base package (closed-loop) + IndraMotion MLD-S
	FWA-INDRV*-	MPB-	04	VRS-	D5-	1-	***	-ML	base package (closed-loop) + *** + IndraMotion MLD-S

#### Power Sections HCS

**Examples** HCS02.1E-W0012-A-03-NNNV (with integrated 24V supply);  
 HCS03.1E-W0100-A-05-NNBV (with integrated brake transistor)

Product	Line	Design	Power supply	Cooling mode	Maximum current	Protection mode	Mains connecting voltage	Other design
HCS	02	1	E	W	0012	A	03	NNNV

Fig. 4-1: Basic structure of type code

## Control Sections BASIC CSB01.1N

Example CSB01.1.N-FC-NNN-NNN-NN-C-NN-FW

Product	Line	Design	Configuration option	Master communication	Option 1	Option 2	Safety option	Display	Other design	Firmware (to be ordered extra)
CSB	01	1	N	FC	NNN	NNN	NN	C	NN	FW

Fig. 4-2: Basic structure of type code

## Additional Components

## Mains Choke HNL

Example HNL01.1E-0980-N0026-A-480-NNNN

Product	Line	Design	Supply system	Nominal inductance	Additional option	Nominal current	Degree of protection	Mains connecting voltage	Other design
HNL	01	1	E	0980	N	0026	A	480	NNNN

Fig. 4-3: Basic structure of type code

## Mains Filter HNF, HNK

Example HNF01.1A-F240-R0094-A-480-NNNN

Product	Line	Design	EMC-area per DIN 61800-3	Applications	Supply system	Nominal current	Degree of protection	Mains connecting voltage	Other design
HNF	01	1	A	F240	R	0094	A	480	NNNN
HNK	01	1	A	A075	E	0050	A	500	NNNN

Fig. 4-4: Basic structure of type code

**Motor Filter HMF**

**Example** HMF01.1A-N1K5-E0070-A-500-NNNN

Product	Line	Design	Mounting style	Filter class	Motor frequency	Switching frequency	Nominal current	Degree of protection	Voltage rating	Other design
HMF	01	1	A	N	1K5	E	0070	A	500	NNNN

Fig. 4-5: Basic structure of type code

**Braking Resistor HLR**

**Example** HLR01.1N-1K08-N05R0-A-007-NNNN

Product	Line	Design	Mounting style	Continuous output	Additional option	Resistance	Degree of protection	DC bus nominal voltage	Other design
HLR	01	1	N	1K08	N	05R0	A	007	NNNN

Fig. 4-6: Basic structure of type code

**Accessories**

**HAS01.1**

**Example** HAS01.1-050-048-NN

Product	Line	Design	Device width	Bus-bar	Other design
HAS	01	1	050	048	NN

Fig. 4-7: Basic structure of type code

**HAS02.1**

**Example** HAS02.1-001-NNN-NN

Product	Line	Design	Device assignment	Other feature	Other design
HAS	02	1	001	NNN	NN

Fig. 4-8: Basic structure of type code

**Type Plates**

Each drive component is marked by a type designation. There is a type plate attached to all devices.

**Type Plates at the Drive Controller**

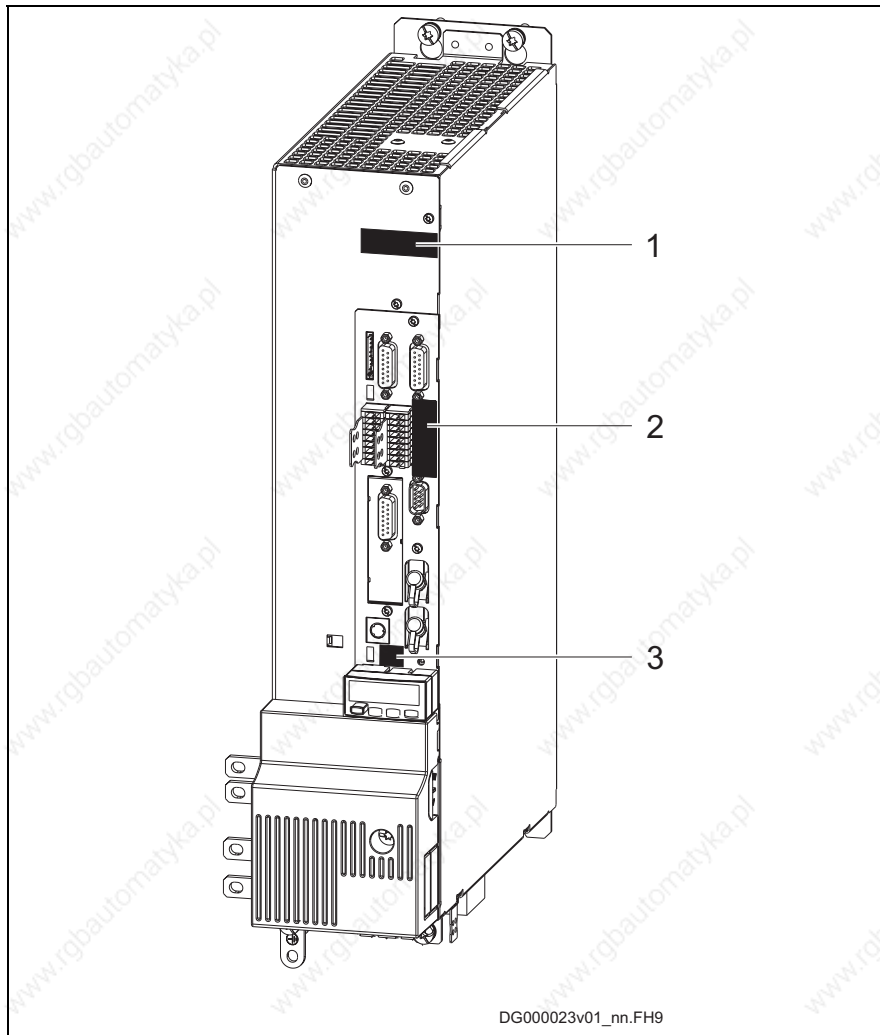

- 1: Power section type plate
- 2: Control section type plate
- 3: Firmware type plate

Fig. 4-9: Type plates at the drive controller

### Type Plates at the Control Section

#### Control Section Type Plate

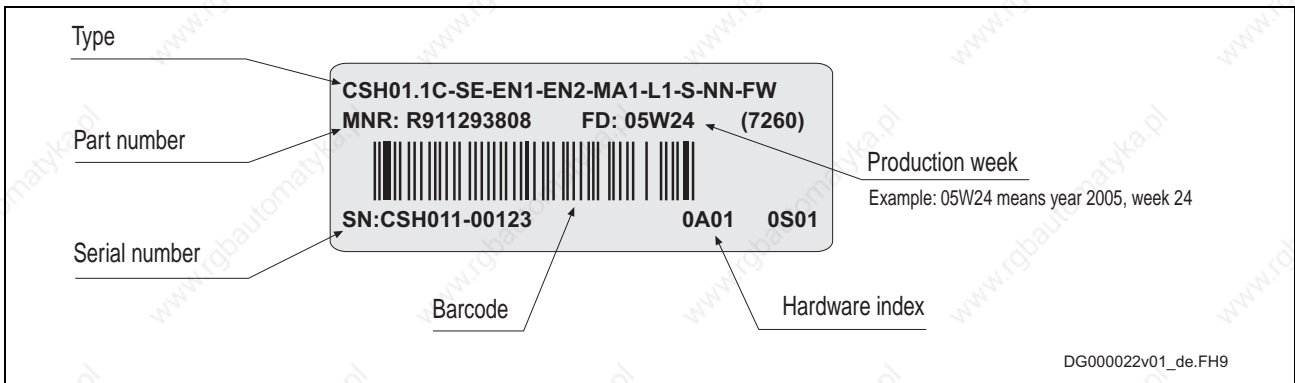

Fig. 4-10: Control section type plate

#### Firmware Type Plate

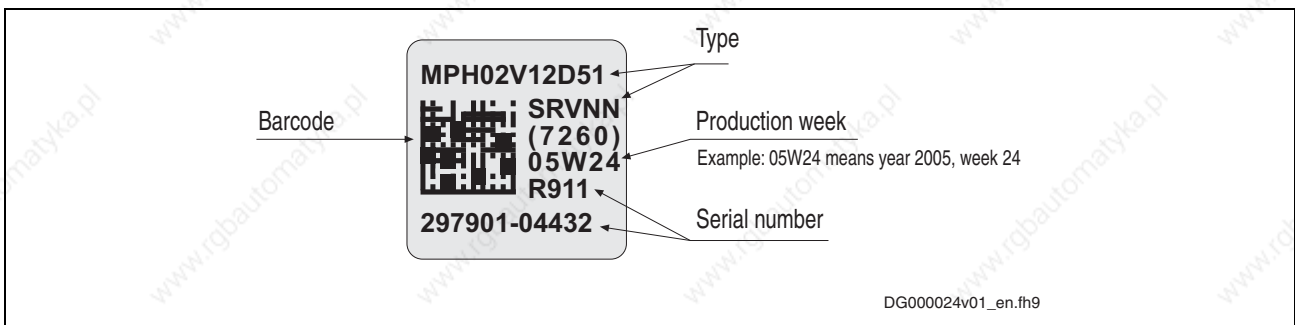

Fig. 4-11: Firmware type plate (example)

## 4.2 Transport and Storage

### Transport of the Devices

#### Conditions

temperature	-25...70 °C
relative humidity	5...95%; climatic category 2K3
absolute humidity	1...60 g/m <sup>3</sup> climatic category 2K3
moisture condensation	not allowed
icing	not allowed
shock test out of operation according to EN 60068-2-27	half sine in 3 axes: 10g / 11ms

Fig. 4-12: Conditions for transport

### Storage of the Devices

#### Conditions

temperature	-25...55 °C
relative humidity	5...95%; climatic category 1K3
absolute humidity	1...29 g/m <sup>3</sup> climatic category 1K3
moisture condensation	not allowed
icing	not allowed

Fig. 4-13: Conditions for storage

#### Extended Storage

Some devices contain electrolytic capacitors which may deteriorate during storage.

**Note:** When storing these devices for a longer period of time, operate them once a year for at least 1 hour with power ON:

- devices HCS with mains voltage  $U_{LN}$

## 4.3 Installation Conditions

### Ambient and Operating Conditions

The drive controllers and their additional components are designed for control cabinet mounting!

**Note:** The user must check that the ambient conditions, in particular the control cabinet temperature, are complied with by calculating the heat levels in the control cabinet and making the corresponding measurements.

In the Technical Data the power dissipation is indicated as an input value for calculating the heat levels.

Designation	Data
degree of protection	IP20 according to IEC529
ambient temperature	0...+40 °C
ambient temperature with power reduction	0...+55 °C; see characteristic in Fig. 4-15
temperature during storage	see section 4.2 Transport and Storage
temperature during transport	see section 4.2 Transport and Storage
installation altitude with nominal data	<1000 m above sea level
installation altitude with power reduction *	see characteristic in Fig. 4-16
maximum installation altitude *	4000 m (upper temperature level reduced to 40 °C instead of 55 °C)
relative humidity (operation)	5%...95% Cl.3K5 with restriction, as not -5 °C
absolute humidity	1...29 g/m <sup>3</sup>
climatic category	Cl. 3K3 according to IEC721
degree of dirt contamination	degree of dirt contamination 2 in accordance with EN50178
dust, steam	allowed according to EN 50178, table A.2
sine vibration during operation according to EN 60068-2-6	amplitude and frequency: 0.15 mm (peak-peak) at 10...57 Hz acceleration and frequency: 1 g at 57...150 Hz tolerance: ±15 %
noise vibration (random) during operation according to IEC 68-2-36	frequency: 20...150 Hz spectral acceleration density amplitude: 0.005 g <sup>2</sup> /Hz tolerance: ± 3 dB rms value of the total acceleration: 1.0 g

\* For installation altitudes of more than 2000 m, an overvoltage limiter for transient overvoltage 1.2/50 μs must be installed in the installation or building in order to limit the voltage to 1.0 kV between the outer conductors and to 2.5 kV between conductor-ground.

Fig. 4-14: Ambient and operating conditions

## Capacity Utilization

Where installation conditions differ, the following performance data are reduced in accordance with the diagrams (see "Fig. 4-15:" and "Fig. 4-16:"):

### drive controller:

- allowed continuous DC bus power
- continuous power of braking resistor
- continuous current

### motor:

- power
- continuous torque at standstill
- S1 continuous torques
- short-time service torque MKB

If differing ambient temperatures and higher installation altitudes occur simultaneously, both capacity utilization factors must be multiplied. The installation altitude must only be taken into account once, deviating ambient temperatures must be taken into account separately for motor and drive controller.

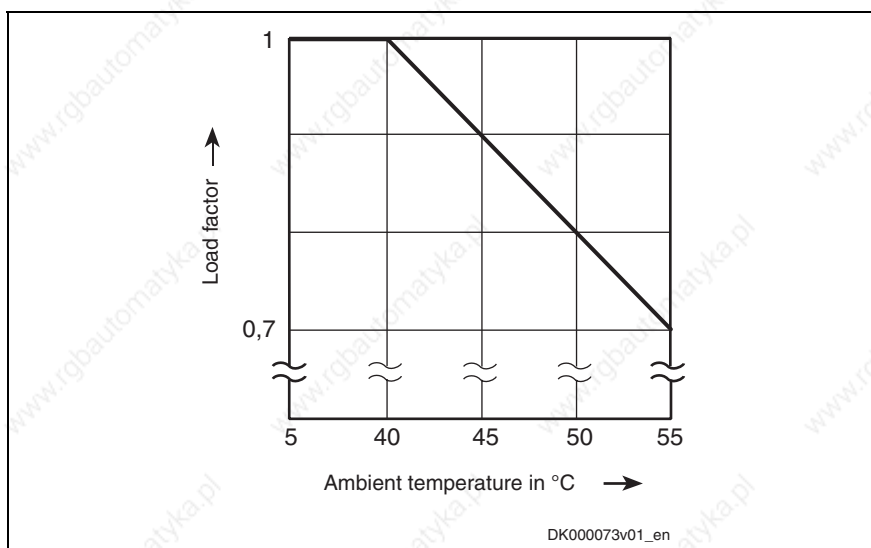

Fig. 4-15: Capacity utilization at higher ambient temperature



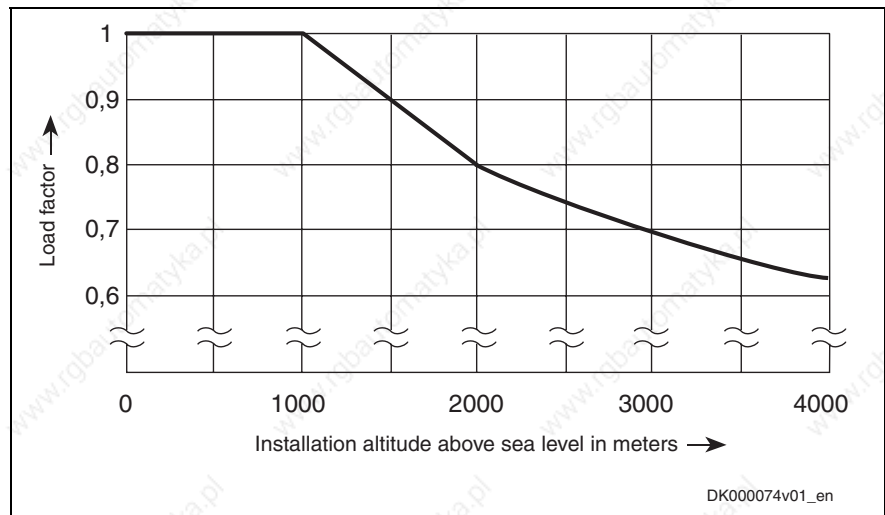

Fig. 4-16: Capacity utilization at higher installation altitude

## Compatibility with Foreign Matters

All Rexroth controls and drives are developed and tested according to the state-of-the-art technology.

As it is impossible to follow the continuing development of all materials (e.g. lubricants in machine tools) which may interact with our controls and drives, it cannot be completely ruled out that any reactions with the materials used by Bosch Rexroth might occur.

For this reason, before using the respective material a compatibility test has to be carried out for new lubricants, cleaning agents etc. and our housings/our housing materials.



## 5 Electrical Data

### 5.1 Power Sections

Unless otherwise specified, the following data apply to

- $T_a = T_{amax}$
- $U_{LN} = 3AC400V$
- use of HNL and HNK mains chokes

#### Type Current and Connected Load

Compact converter	Type current	Attached mains choke HNL, HNK	Nominal motor power (2)	Connected load	Mains input contin. current	Nominal fuse current / fuse type characteristic gL	Contin. current (1)	Peak current (1)
				$S_{LN}$	$I_{L\_cont}$	Type	$I_{out\_cont1}$	$I_{out\_max}$
			[kW]	[kVA]	[A]	[A]	[A]	[A]
HCS02	W0012	HNL01.1E-1000-N0012	1,5	3,5	6	10	4	12
HCS02	W0028	HNL01.1E-1000-N0012	4,0	7,3	13	20	11	28
HCS02	W0054	HNL01.1E-1000-N0020	7,5	13,3	19	25	22	54
HCS02	W0070	HNL01.1E-0600-N0032	11	18,5	30	35	28	70
HCS03	W0070	HNL01.1E-0571-N0050 HNK01.1A-A075-E0080	18,5	35	50	3NA6820-4	45	70
HCS03	W0100	HNL01.1E-0362-N0080; HNK01.1A-A075-E0080	30	55,2	80	3NA6824-4	73	100
HCS03	W0150	HNL01.1E-0240-N0106 HNK01.1A-A075-E0106	45	72,9	106	3NA6832-4	95	150
HCS03	W0210	HNL01.1E-0170-N0146 HNK01.1A-A075-E0146	75	99,3	146	3NA6836-4	145	210

(1) at  $f_s = 4$  kHz; without overload

(2) for standard motor, when using mains choke HNL01; at 3 AC 400 V variable torque, low overload

Fig. 5-1: Type current and connected load

## Control Voltage Supply

**Note:** The control sections are supplied via the terminal connectors 24V and 0V at the power section (24V supply).

**Note:** The isolated inputs/outputs at X31 and X32 are not supplied via the connections of the 24V supply of the power section. A separate voltage supply is required for these inputs/outputs.

**Note:** Overvoltage of more than 33 V has to be discharged by means of the appropriate electrical equipment of the machine or installation.

This equipment includes:

- 24V power supply units that reduce incoming overvoltages to the allowed value.
- Overvoltage limiters at the control cabinet input that limit existing overvoltage to the allowed value. This, too, applies to long 24V lines that have been run in parallel to power cables and mains cables and can absorb overvoltages by inductive or capacitive coupling.

Designation	Symbol	Unit	
24V control voltage supply			
HCS02.1E; HCS03.1E	$U_{N3}$	V	<ul style="list-style-type: none"> <li>• <math>24 \pm 20\%</math> (if no motor holding brake has to be supplied)</li> <li>• If motor holding brakes are to be supplied, observe the data of the motor documentation. The following values are normally sufficient:   <math>24 \pm 5\%</math> at motor cable length &lt; 50 m  <math>26 \pm 5\%</math> at motor cable length &gt; 50 m</li> </ul>
max. ripple content	w	-	mustn't exceed the control voltage range
max. allowed overvoltage	$U_{N3max}$	V	33 (max. 1 ms)
Power consumption of power sections 1)			
HCS02.1E-W0012	$P_{N3}$	W	12
HCS02.1E-W0028	$P_{N3}$	W	14
HCS02.1E-W0054	$P_{N3}$	W	23
HCS02.1E-W0070	$P_{N3}$	W	23
HCS03.1E-W0070	$P_{N3}$	W	23
HCS03.1E-W0100	$P_{N3}$	W	25
HCS03.1E-W0150	$P_{N3}$	W	25
HCS03.1E-W0210	$P_{N3}$	W	30
Power consumption of control sections 2)			
CSB01.1N-FC...	$P_{N3}$	W	7,5
CSB01.1N-PB...	$P_{N3}$	W	7,5
Typ. inrush current of control sections			

CSB01.1N-FC...	$I_{EIN3}$	A	1,5 (pulse width $t_{EIN3lade}$ ca. 120 ms)
CSB01.1N-PB...	$I_{EIN3}$	A	5 (pulse width $t_{EIN3lade}$ ca. 40 ms)
Power consumption of optional modules according to type code 3), 4)			
C	$P_{N3}$	W	1,0
EN1	$P_{N3}$	W	6,0
EN2	$P_{N3}$	W	5,5
ENS	$P_{N3}$	W	5,5
MA1	$P_{N3}$	W	2,0
MD1	$P_{N3}$	W	1,0
S	$P_{N3}$	W	1,0

- 1) plus control section with optional modules
- 2) plus optional modules
- 3) code from the control section type code
- 4) at max. allowed output load without circuits to be supplied externally

Fig. 5-2: Control voltage

## Power Voltage Supply- Mains Connection

Designation	Symbol	Unit	HCS02.1E	HCS03.1E
allowed range of mains input voltage, three-phase; TN-S, TN-C, TT mains	$U_{LN}$	V	3 * AC (200...500) +10%	3 * AC (400...500) +10% -15%
allowed range of mains input voltage, three-phase; IT mains	$U_{LN}$	V	3 * AC (200...230) +10%	not allowed
allowed range of mains input voltage, single-phase	$U_{LN}$	V	1 * AC (200...250) +-10%	not allowed
rotary field			no rotary field condition	
allowed range of mains frequency	$f_{LN}$	Hz	(50...60) + - 2	
max. allowed mains frequency change	$d f_{LN}/t$	Hz/s	2% * $f_{LN}$	

Fig. 5-3: Extended range of power voltage

**Note:** When using HCS02 and HCS03 devices in the mains voltage range up to 3 \* AC 500 V, make sure the additional components you use may be operated in this mains voltage range. NFD mains filters, for example, can only be used up to 3 \* AC 480 V.

## Limited Length of Motor Power Cables

Keep in mind, that the allowed maximum motor cable length is depending on the switching frequency of the power output stage. On principle, the higher the switching frequency, the shorter the allowed cable length (in order to protect the drive controllers against overload).

**Note:** Always use switching frequencies supported by the components of your drive system. Observe the technical data of the drive controllers and motors.

See also Parameter Description "P-0-0001, Switching frequency of the power output stage".

### Limited Lengths of Motor Power Cables

The lengths indicated in the table below are recommended as guide values (at an ambient temperature of  $\leq 40^\circ\text{C}$  in accordance with EN 60 204).

Allowed line lengths for motor connection **without** filter measures at motor output:

PWM frequency [kHz]	Max. allowed line length [m]	
	Shielded line	Unshielded line <sup>1)</sup>
2 <sup>2)</sup>	100	175
4	75	150
8	38	150
12	25	not allowed
16	18	not allowed

1) only allowed at HCS drive controllers

2) depending on the drive controller

Fig. 5-4: Line lengths

Operation with unshielded motor cables of up to 150 m

- aims at applications with "operation without encoder" (Open Loop)
- does not include the control voltage lines to the motor
- requires additional measures with regard to EMC on the part of the operating company

Allowed line lengths for motor connection **with** additional components HMF or HML:

PWM frequency [kHz]	Max. allowed line length [m]	
	Shielded line	Unshielded line <sup>1)</sup>
4 <sup>2)</sup>	75	200

1) only allowed at HCS03 drive controllers

2) higher PWM frequencies are not allowed

Fig. 5-5: Line lengths

### Documentation Motor Power Cables

The documentation "**Rexroth Connection Cables; Selection Data**" is available for selecting the motor power cables and other connections, such as encoder cables.

Rexroth IndraDrive drive systems have to be equipped with shielded motor power cables of the RKL line.

**Third-Party Motor Power Cables**

Requirements on third-party motor power cables:

Maximum allowed **cable length** at A1, A2, A3:

- see description above

Maximum allowed **capacitance per unit length** at A1, A2, A3:

- against ground, each: 0.5 nF/m
- against each other: 0.5 nF/m

Maximum allowed **inductance per unit length** at A1, A2, A3:

- 100 nH/m each

---

**Note:** If you use third-party motor power cables not corresponding to the requirements, Rexroth's guarantee for the drive system will expire.

Use ready-made Rexroth cables.

---

## 5.2 Control Sections

### Relay Contact Type 1

Data	Unit	Min.	Typ.	Max.
current load capacity	A			DC 1 AC 2
voltage load capacity	V			DC 30 AC 250
minimum contact load	mA	10		
contact resistance at minimum current	mOhm			1000
switching actions at max. time constant of load		100.000		
number of mechanical switching cycles			$1 * 10^6$	
time constant of load	ms			50
pick up delay	ms			10
drop out delay	ms			10

Fig. 5-6: Relay contacts type 1

### Relay Contact Type 2

Data	Unit	Min.	Typ.	Max.
current load capacity	A			DC 1
voltage load capacity	V			DC 30
minimum contact load	mA	10		
contact resistance at minimum current	mOhm			1000
switching actions at max. time constant of load			$1 * 10^6$	
number of mechanical switching cycles			$1 * 10^8$	
time constant of load	ms	ohmic		
pick up delay	ms			10
drop out delay	ms			10

Fig. 5-7: Relay contacts type 2



### Relay Contact Type 3

Data	Unit	Min.	Typ.	Max.
current load capacity	A			DC 1
voltage load capacity	V			DC 30
minimum contact load	mA	10		
contact resistance at minimum current	mOhm			1000
switching actions at max. time constant of load			1 * 10 <sup>6</sup>	
number of mechanical switching cycles			1 * 10 <sup>7</sup>	
time constant of load	ms	ohmic		
pick up delay	ms			10
drop out delay	ms			10

Fig. 5-8: Relay contacts type 3

### Digital Inputs/Outputs

#### Digital Inputs

The digital inputs correspond to IEC 61131, type 1.

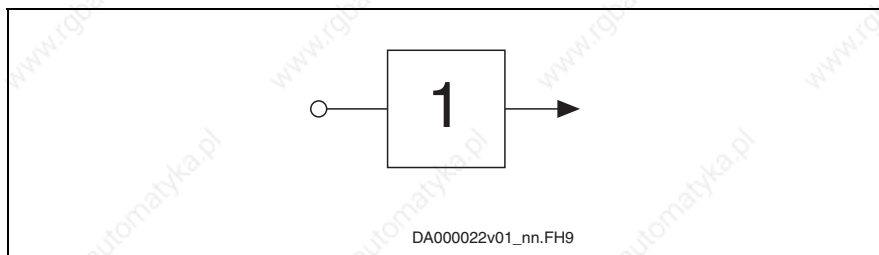

Fig. 5-9: Symbol of digital input

Data	Unit	Min.	Typ.	Max.
allowed input voltage	V	-3		30
On	V	15		
Off	V			5
input current	mA	2		5
input resistance	kOhm	non-linear, varies depending on input voltage		
sampling frequency	kHz	depending on firmware		
probe input delay	us		1	

Fig. 5-10: Digital inputs

**Note:** **Probe inputs** are fast inputs. For triggering use bounce-free switches.

## Digital Outputs

The digital outputs correspond to IEC 61131.

**Note:** Do not operate digital outputs at low-resistance sources.  
Observe Functional Description of the firmware section "Notes on Commissioning" particularly parameter P-0-0302, Digital I/O, Direction.

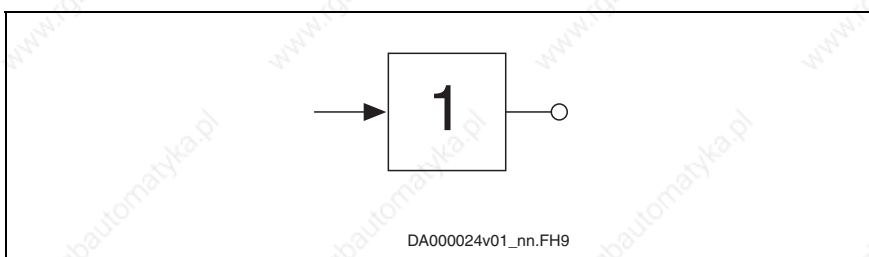

Fig. 5-11: Symbol of digital output

Data	Unit	Min.	Typ.	Max.
output voltage "ON"	V	Uext - 0,5	24	Uext
output voltage "OFF"	V			2,1
output current "OFF"	mA			0,05
allowed output current per output	mA			500
allowed output current total or per group	mA			1000
update interval	ns	depending on firmware		
short circuit protection		present		
overload protection		present		
allowed energy content of connected inductive loads, e.g. relay coils; only allowed as single pulse	mJ			400

Fig. 5-12: Digital outputs

**Note:** The digital outputs have been realized with so-called high-side switches. This means that these outputs can actively supply current but not drain it.

**Note:** The energy absorption capacity of the outputs is used to limit voltage peaks caused when inductive loads are switched off.  
Limit voltage peaks by using free-wheeling diodes directly at the relay coil.

## Analog Inputs/Outputs

The analog inputs correspond to IEC 61 131.

### Analog Input Type 1

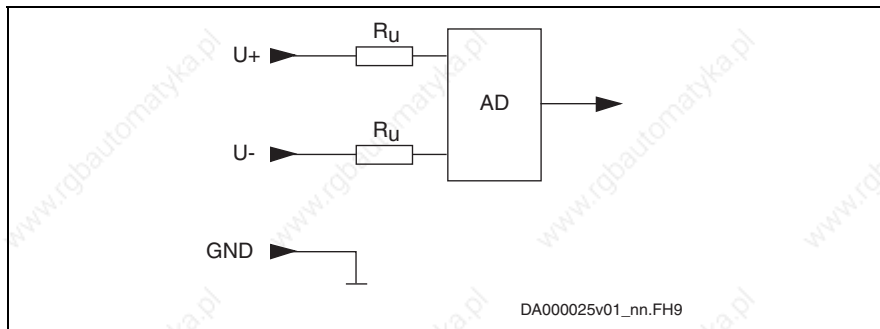

AD: analog/digital converter  
 Fig. 5-13: Analog voltage inputs

Data	Unit	Min.	Typ.	Max.
allowed input voltage voltage inputs	V	-10		+10
input resistance voltage input	kOhm		180	
input bandwidth	kHz		6	
common-mode range	V	-20		+20
common-mode rejection	dB			
relative measuring error at 90% $U_{\text{emax}}$	%	-1		+1
converter width A/D converter incl. polarity sign	Bit		10	
oversampling			8-fold	
dynamic converter width with oversampling	Bit		12	
resulting resolution	mV/lnk		5,5	
cyclic conversion	us	500 (depending on firmware)		
conversion time	us		n.s.	

Fig. 5-14: Analog voltage inputs

## Analog Input Type 2

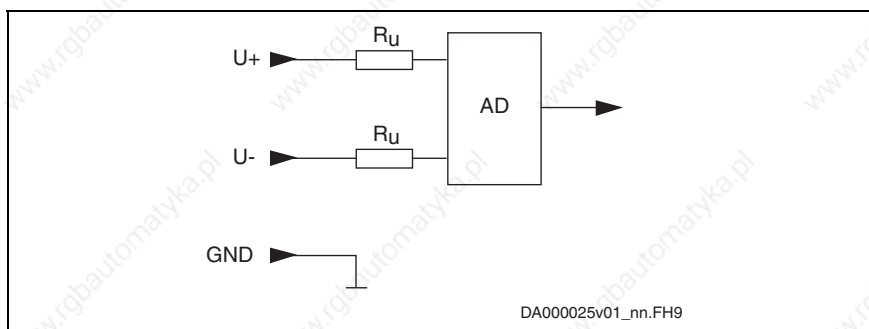

AD: analog/digital converter

Fig. 5-15: Analog voltage inputs

Data	Unit	Min.	Typ.	Max.
allowed input voltage voltage inputs	V	-10		+10
input resistance voltage input	kOhm	1000		
input bandwidth	kHz		50	
common-mode range	V	-50		+50
common-mode rejection	dB	70		
relative measuring error at 90% $U_{\text{emax}}$	%	-0,3		+0,3
converter width A/D converter incl. polarity sign	Bit		12	
oversampling			8-fold	
dynamic converter width with oversampling	Bit		14	
resulting resolution	mV/lnk		1,25	
cyclic conversion	us	500 (depending on firmware)		
conversion time	us		40	

Fig. 5-16: Analog voltage inputs

### Analog Input Type 3

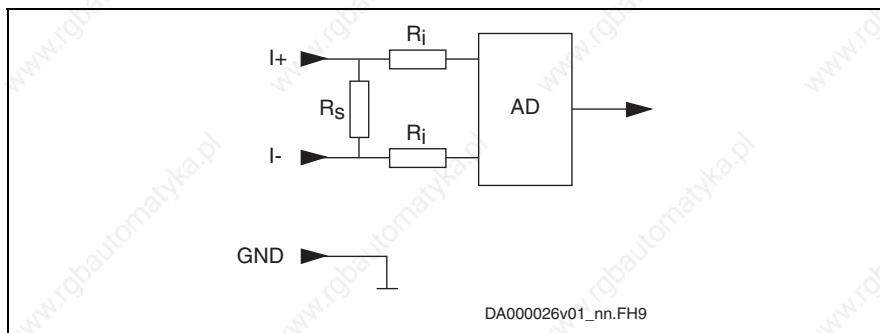

AD: analog/digital converter

Fig. 5-17: Analog current inputs

Data	Unit	Min.	Typ.	Max.
allowed input current	mA	0		+20
input resistance	Ohm		200	
input bandwidth	kHz		3	
common-mode range	V	-20		+20
common-mode rejection	dB			
relative measuring error at 90% $U_{emax}$	%	-1		+1
converter width A/D converter incl. polarity sign	Bit		10	
oversampling			8-fold	
dynamic converter width with oversampling	Bit		12	
resulting resolution	$\mu A/lnk$		5,45	
cyclic conversion	us	500 (depending on firmware)		
conversion time	us		n.s.	

Fig. 5-18: Analog current inputs

## Analog Input Type 4

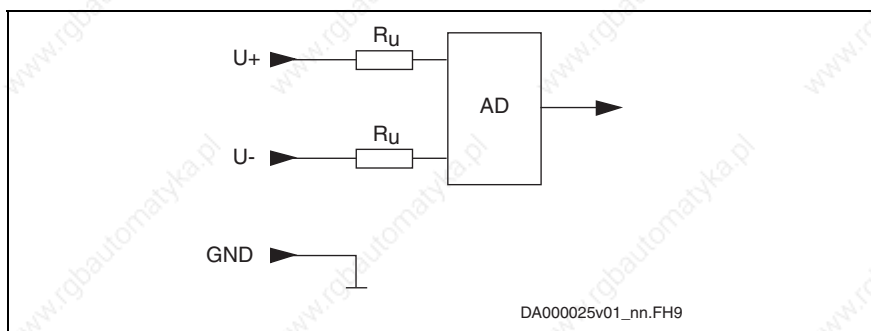

AD: analog/digital converter

Fig. 5-19: Analog voltage inputs

Data	Unit	Min.	Typ.	Max.
allowed input voltage voltage inputs	V	-10		+10
input resistance voltage input	kOhm		2	
input resistance voltage input CSH01.2C	kOhm		160	
input bandwidth	kHz		10	
common-mode range	V	-20		+20
common-mode rejection	dB			
relative measuring error at 90% $U_{emax}$	%	-1		+1
converter width A/D converter incl. polarity sign	Bit		12	
oversampling			8-fold	
dynamic converter width with oversampling	Bit		14	
resulting resolution	mV/lnk		1,23	
cyclic conversion	us	500 (depending on firmware)		
conversion time	us		n.s.	

Fig. 5-20: Analog voltage inputs

## Analog Output Type 1

Data	Unit	Min.	Typ.	Max.
output voltage	V	0		+10
output load	kOhm	2		
output current	mA	0		+5
converter width digital/analog converter incl. polarity sign	Bit	10		
resolution	mV/Ink	9,8		
conversion time (incl. response time)	us		10	
cyclic conversion	us	depending on firmware		
short circuit protection		present		
overload protection		present		

Fig. 5-21: Analog outputs type 1

## Analog Output Type 2

Data	Unit	Min.	Typ.	Max.
output voltage	V	0		+5
output load	kOhm	5		
output current	mA	0		+1
converter width digital/analog converter incl. polarity sign	Bit	8		
resolution	mV/Ink	19,5		
accuracy at R=5 kOhm	%	5 of FMR		
accuracy at R=10 kOhm	%	2,5 of FMR		
conversion time (incl. response time)	us		10	
cyclic conversion	us	depending on firmware		
short circuit protection		present		
overload protection		present		

FMR: final value of measuring range

Fig. 5-22: Analog outputs type 2

### Analog Output Type 3

Data	Unit	Min.	Typ.	Max.
output voltage	V	-10		+10
output load	kOhm	1		
output current	mA	0		+1
converter width digital/analog converter incl. polarity sign	Bit	12		
resolution	mV/Ink	5		
accuracy at R = 1 kOhm	%	1 of FMR		
accuracy at R = 10 kOhm	%	0,2 of FMR		
conversion time (incl. response time)	us		10	
cyclic conversion	us	depending on firmware		
short circuit protection		present		
overload protection		present		

FMR: final value of measuring range

Fig. 5-23: Analog outputs type 3



### 5.3 Additional Components

#### Mains Filter HNF

	Unit	HNF01.1A- ... -A-480-NNNN											
		F240-E0051	M900-E0051	F240-E0125	M900-E0125	F240-E0202	M900-E0202	F240-R0026	M900-R0026	F240-R0065	M900-R0065	F240-R0094	M900-R0094
Power dissipation	W	<89	<91	<127	<174	<238	<373	<73	<77	<163	<157	<135	<146
Phase current (continuous current)	A	51	51	125	125	202	202	26	26	65	65	94	94
Phase current (peak current <sup>1)</sup> )	A	77	77	188	188	303	303	65	65	163	163	235	235
Leakage current at filters input (line side)	A	<2	<2	<2,2	<2,2	<2,5	<2,5	<2	<2	<2	<2	<2,2	<2,2
Leakage current at filters output (load side)	A	<2	<2	<2,2	<2,2	<2,5	<2,5	<2	<2	<2	<2	<2,2	<2,2
allowed THD (Total Harmonic Distortion)	%	see Project Planning Manual "Rexroth IndraDrive Drive System"											
Reduction of allowed operating data due to harmonic content	-	see Project Planning Manual "Rexroth IndraDrive Drive System"											
Input supply voltage	V	3 x AC 380...480V ±10%, 50/60Hz ±2%											
Sum of leakage currents at filters input with power supply unit switched off:  • 1 phase failed • 2 phases failed	A	<ul style="list-style-type: none"> <li>• &lt; 0,83</li> <li>• &lt; 1,4</li> </ul>											
Leakage resistance (Phase – Ground)	MOhm	> 15											
Protection category	-	IP20											
Materials	-	free of asbestos and silicone											
Terminal L1, L2, L3 resp. L1.1, L2.1, L3.1:													
Cross section flexible min.	mm <sup>2</sup>	0,5	0,5	16	16	50	50	0,5	0,5	10	10	16	16
Cross section flexible max.	mm <sup>2</sup>	16	16	50	50	150	150	10	10	25	25	50	50
Cross section rigid min.	mm <sup>2</sup>	0,5	0,5	16	16	35	35	0,5	0,5	6	6	16	16
Cross section rigid max.	mm <sup>2</sup>	25	25	50	50	150	150	16	16	35	35	50	50
Cross section AWG min.	--	20	20	6	6	2	2	20	20	10	10	6	6
Cross section AWG max.	--	4	4	0	0	00/3	00/3	6	6	2	2	0	0
Tightening torque	Nm	4,8 ±0,5	4,8 ±0,5	<25	<25	<25	<25	4,8 ±0,5	4,8 ±0,5	4,8 ±0,5	4,8 ±0,5	<25	<25

1) duration: 300 ms ;  
 cycle duration:  
 for feeding units: 0,67 s;  
 for regenerating units: 1,42 s;  
 base load: 60% (continuous current)

Fig. 5-24: Data HNF

## Mains Filter (-Combination) HNK

Mains filter HNK01.1A-A075	Unit	E0050	E0080	E0106	E0146
Nominal voltage	V	3*AC400...500			
Nominal current	A	50	80	106	146
Inductance	$\mu\text{H}$	571	362	240	170
Connection cross section	$\text{mm}^2$	16 (AWG 6)	25 (AWG 3)	25 (AWG 3)	50 (AWG 1/0)
Protection category	-	IP20			
Weight	kg	15	20	20	28

Fig. 5-25: Data HNK

## Mains Choke HNL01.1E (feeding)

Mains choke	$U_N$ [V]	$I_N$ [A]	$L_N$ [ $\mu\text{H}$ ]	$P_V$ [W]	$I_{\max}$ [A]	$L_{\min}$ at $I_{\max}$	Connection cross section [ $\text{mm}^2$ ]
HNL01.1E-1000-N0012-A-500-NNNN	500	12	3 x 1000	40	25	50% of $L_N$	4 (a, b: 4)
HNL01.1E-1000-N0020-A-500-NNNN	500	20	3 x 1000	60	50	50% of $L_N$	6 (a, b: 4)
HNL01.1E-0600-N0032-A-500-NNNN	500	32	3 x 600	75	80	50% of $L_N$	10 (a, b: 4)
HNL01.1E-0571-N0050-A-500-NNNN	500	50	3 x 571	50	100	50% of $L_N$	16 (a, b: -)
HNL01.1E-0400-N0051-A-480-NNNN	480	51	3 x 400	165	77	50% of $L_N$	16 (a, b: 2,5)
HNL01.1E-0362-N0080-A-500-NNNN	500	80	3 x 362	80	160	50% of $L_N$	35 (a, b: -)
HNL01.1E-0240-N0106-A-500-NNNN	500	106	3 x 240	100	212	50% of $L_N$	50 (a, b: -)
HNL01.1E-0200-N0125-A-480-NNNN	480	125	3 x 200	170	188	50% of $L_N$	70 (a, b: 2,5)
HNL01.1E-0170-N0146-A-500-NNNN	500	146	3 x 170	130	292	50% of $L_N$	95 (a, b: -)
HNL01.1E-0100-N0202-A-480-NNNN	480	202	3 x 100	200	303	50% of $L_N$	150 (a, b: 2,5)

Fig. 5-26: Data HNL

## Temperature Contact a, b

**Switching Capacity** 1 A / AC 250 V; DC 24 V

**Switching Temperature** 125 °C

**Note:** HNL01.1E mains chokes of type 1 are equipped with a temperature contact (a, b), types 2, 3 and 4 are not.

## Mains Choke HNL01.1E-\*\*\*\*-S (Current-Compensated)

		HNL01.1 ... -A-480-NNNN					
	Unit	E-5700-S0051	E-2800-S0125	E-3400-S0202	R-4200-S0026	R-6300-S0065	R-3000-S0094
Weight	kg	11	26	30	12	14	24
Inductance $L_N$	mH	3 x 5,7	3 x 2,8	3 x 3,4	3 x 4,2	3 x 6,3	3 x 3,0
Nominal current	A	51	125	202	26	65	94
Peak current <sup>1)</sup>	A	77	188	303	65	163	235
Total leakage current at power terminal	A	< 2	< 2,2	< 2,2	< 2	< 2	< 2
Allowed power dissipation at nominal current and maximum leakage current	W	83	179	320	80	138	142
Input supply voltage	3 x AC 380...480V $\pm 10\%$ , 50/60Hz $\pm 2\%$						
Minimum inductance $L_{min}$	0,8 * $L_N$ at $I_{max}$						
Protection category	IP20						

1) duration: 300 ms ;  
 cycle duration:  
 for feeding units: 0,67 s;  
 for regenerating units: 1,42 s;  
 base load: 60%

Fig. 5-27: Data HNL...S

## Braking Resistor HLR

### HLR01.1N-xxxx-Nxxxx-A-007-NNNN

Designation	Symbol	Unit	0300-N17R5	0470-N11R7	0780-N07R0	1K08-N05R0
nominal braking resistance	$R_{DC\_Bleeder}$	Ohm	17,5	11,7	7,0	5,0
braking resistor continuous power, at $T_a \leq 40^\circ C$	$P_{BD}$	kW	0,30	0,47	0,78	1,08
resistance value at $P_{BD}$		$\Omega$	20,5	13,7	8,2	5,8
braking resistor peak power at $U_{DC} = 850 V$	$P_{BS}$	kW	35	52	88	124
max. regenerative power that can be absorbed	$W_{R\_max}$	kWs	37	56	93	130
max. allowed duty cycle	t	s	1	1	1	1
min. allowed cycle time	t	s	120	120	120	120
time constant		s	780	780	780	780
weight	m	kg	3	4,5	5,5	8
connection cross section						
		mm <sup>2</sup>	10	25	25	50
		AWG	8	3	3	1/0

Fig. 5-28: Data

## Braking Resistors for HCS03.1E-W0070

HLR01.1N-xxxx-xxxxx-A-007-NNNN		-01K6-N18R0	-03K5-N19R0	-04K5-N18R0	-06K5-N18R0	-10K0-N18R0
continuous power	kW	1,6	3,5	4,5	6,5	10
resistance value in operating status	$\Omega$	20,0	21,3	20,2	20,2	20,2
type		A5	B1	B2	B2	B3
Energy absorption at peak power, duty cycle $t = x$ sec and load cycle $T = 120$ sec						
energy absorption at peak power	kWs	109	252	432	686	1080
peak power	kW	34	31	33	33	33
t	sec	3,3	8	13	21	32
duty cycle ED	%	2,7	6,7	11	17	27
Braking power at x % ED and a load cycle $T = 120$ sec						
braking power	kW	15	14	14	14	15
t	sec	7,2	18	30	48	72
ED	%	6	15	25	40	60
Connection cross section						
	mm <sup>2</sup>	2,5	4	6	10	10
	AWG	14	12	10	8	8

Fig. 5-29: Technical data for braking resistors at HCS03.1E-W0070

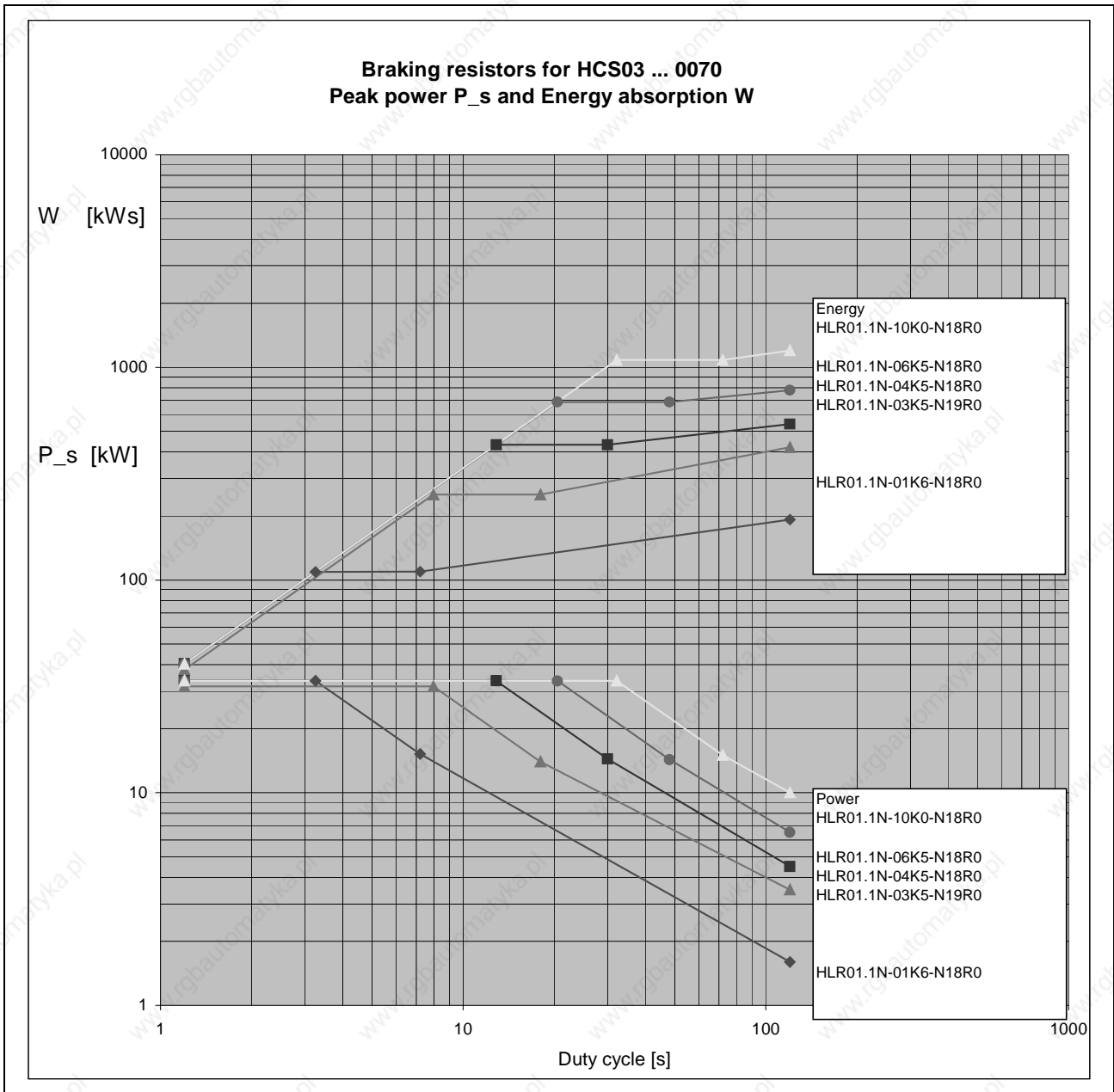

Fig. 5-30: Selection aid for braking resistors for HCS03.1E-W0070

## Braking Resistors for HCS03.1E-W0100

HLR01.1N-xxxx-xxxxx-A-007-NNNN		-02K0-N15R0	-05K0-N15R0	-07K0-N14R0	-09K5-N13R0	-14K5-N13R0
continuous power	kW	2	5	7	9,5	14,5
resistance value in operating status	$\Omega$	16,7	16,9	15,7	14,6	14,6
type		A6	B2	B3	B3	B4
Energy absorption at peak power, duty cycle $t = x$ sec and load cycle $T = 120$ sec						
energy absorption at peak power	kWs	137	360	672	1003	1566
peak power	kW	40	40	43	46	46
t	sec	3,4	9	16	22	34
duty cycle ED	%	2,8	7,5	13	18	28
Braking power at x % ED and a load cycle $T = 120$ sec						
braking power	kW	19	20	22	21	22
t	sec	7,2	18	30	48	72
ED	%	6	15	25	40	60
connection cross section						
	mm <sup>2</sup>	4	6	10	10	16
	AWG	12	10	8	8	6

Fig. 5-31: Technical data for braking resistors at HCS03.1E-W0100

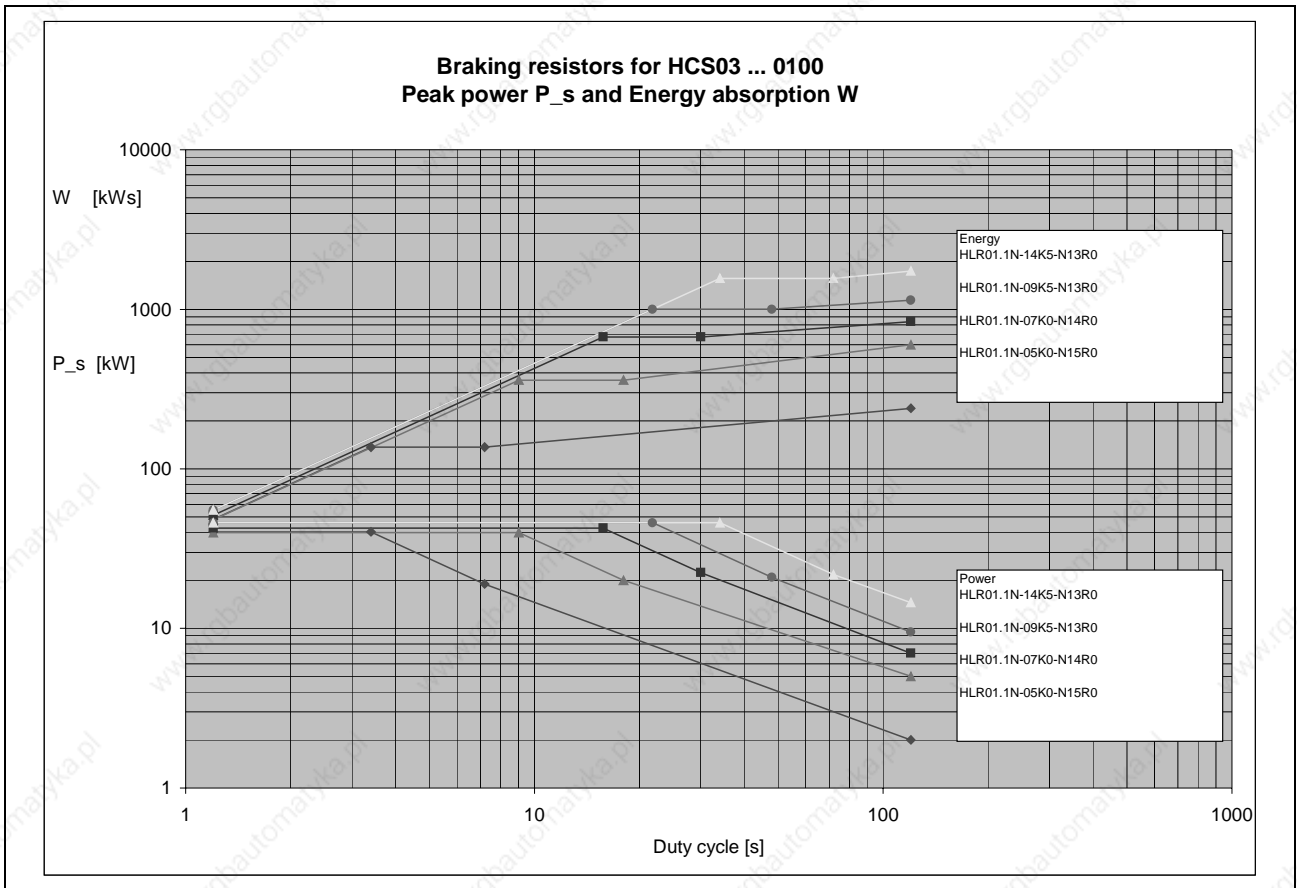

Fig. 5-32: Selection aid for braking resistors for HCS03.1E-W0100

## Braking Resistors for HCS03.1E-W0150

HLR01.1N-xxxx-xxxxx-A-007-NNNN		-04K5-N07R4	-08K5-N08R0	-11K0-N07R3	-15K0-N08R1	-24K0-N07R2
continuous power	kW	4,5	8,5	11	15	24
resistance value in operating status	$\Omega$	8,3	9,0	8,2	9,1	8,1
type		B1	B3	B3	B4	C3
Energy absorption at peak power, duty cycle $t = x$ sec and load cycle $T = 120$ sec						
energy absorption at peak power	kWs	246	612	1056	1584	2592
peak power	kW	81	75	82	74	83
t	sec	3	8,2	13	21	31
duty cycle ED	%	2,5	6,8	11	18	26
Braking power at x % ED and a load cycle $T = 120$ sec						
braking power	kW	34	34	35	33	36
t	sec	7,2	18	30	48	72
ED	%	6	15	25	40	60
connection cross section						
	mm <sup>2</sup>	10	16	25	25	35
	AWG	8	6	3	3	2

Fig. 5-33 Technical data for braking resistors at HCS03.1E-W0150



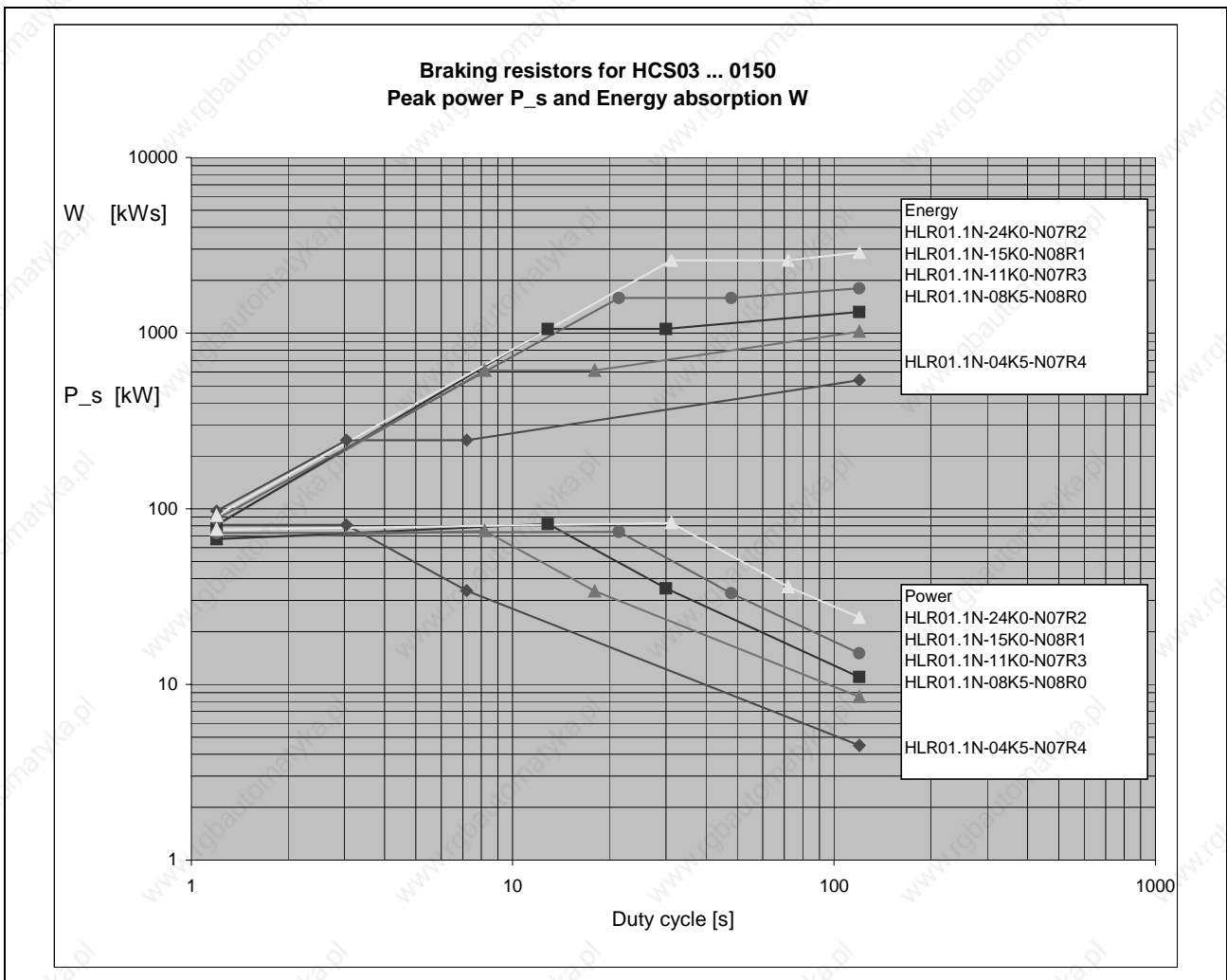

Fig. 5-34: Selection aid for braking resistors for HCS03.1-W0150

## Braking Resistors for HCS03.1E-W0210

HLR01.1N-xxxx-xxxxx-A-007-NNNN		-06K5-N06R1	-12K5-N05R5	-17K0-N05R1	-23K0-N05R5	-36K0-N05R4
continuous power	kW	6,5	12,5	17	23	36
resistance value in operating status	$\Omega$	7	6	6	6	6
type		B2	B4	B5	C2	C4
Energy absorption at peak power, duty cycle $t = x$ sec and load cycle $T = 120$ sec						
energy absorption at peak power	kWs	356	900	1632	2429	3888
peak power	kW	98	109	117	109	111
t	sec	3,6	8,3	14	22	35
duty cycle ED	%	3	6,9	12	18	29
Braking power at x % ED and a load cycle $T = 120$ sec						
braking power	kW	49	50	54	51	54
t	sec	7,2	18	30	48	72
ED	%	6	15	25	40	60
connection cross section						
	mm <sup>2</sup>	16	35	35	50	50
	AWG	6	2	2	1/0	1/0

Fig. 5-35: Technical data for braking resistors at HCS03.1E-W0210

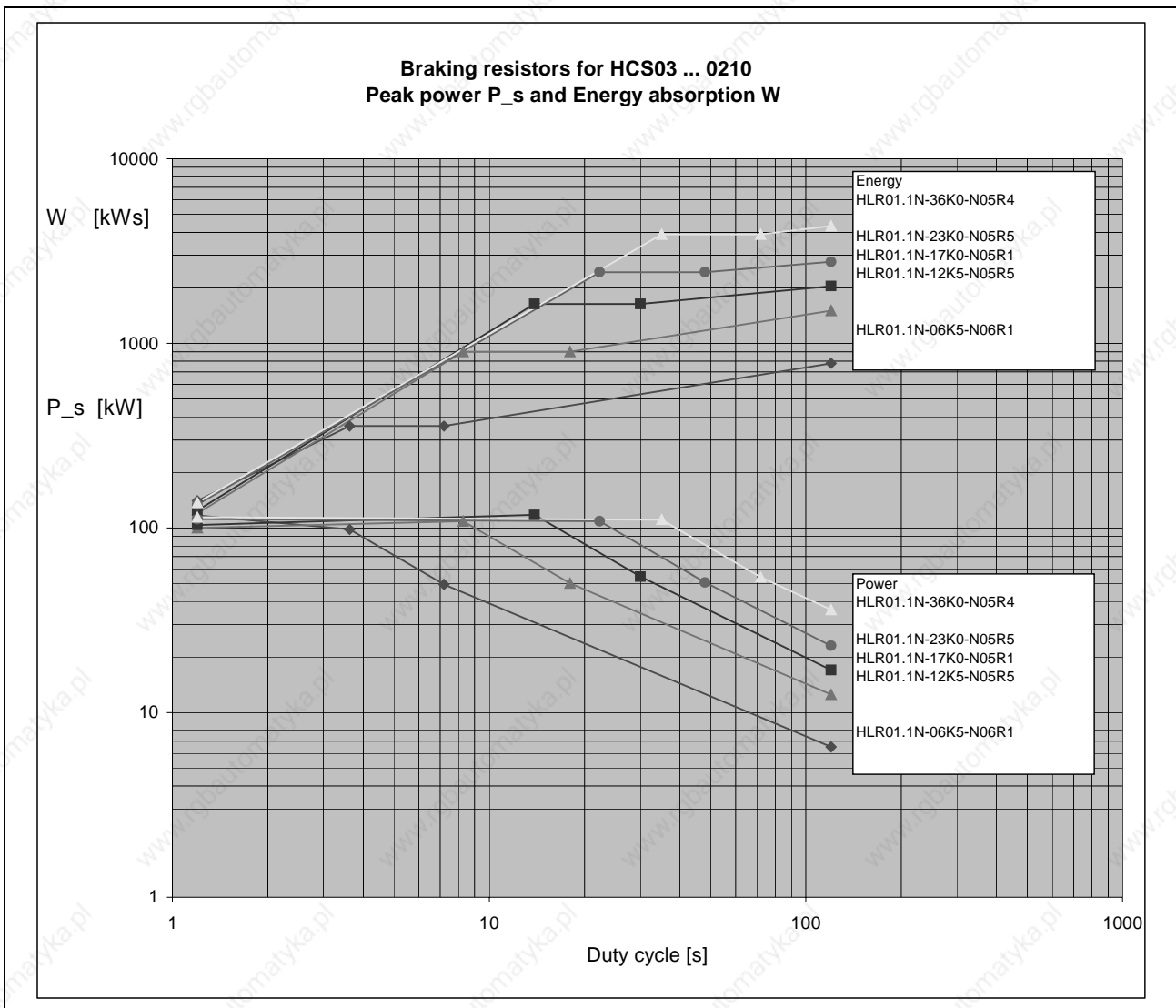

Fig. 5-36: Selection aid for braking resistors for HCS03.1E-W0210

### Line Cross Sections for Reinforced Braking Resistors HLR01.1

According to the standards "Electronic equipment for use in power installations" (EN 50178, chapter 5.3.2.1) and "Adjustable speed electrical power drive systems" (EN 61800-5-1, chapter 4.2.5.4.2), a stationary connection of the equipment grounding conductor is required. The following requirement has to be complied with: cross section of equipment grounding conductor at least 10 mm<sup>2</sup> (mechanical stability).

**Note:** For the equipment grounding conductor run lines with a cross section corresponding to that of the lines for mains connection at the drive controller HCS and having at least 10 mm<sup>2</sup>.

Requirements for line routing:

- The cross sections are valid for one phase each in the case of stranded wires and are specified according to the regulations of VDE0298.
- Up to 50 mm<sup>2</sup>, solid wires in the cable duct.

## Motor Filter HMF

Motor filter	$I_N$ [A]	$P_V$ [W]	$L_M$ [μH]	$f_{out\_max}$ [Hz]	$f_{p\_max}$ [kHz]	du/dt at output [kV / us]	$U_{out\_max}$ [kV]
HMF01.1A-N0K2-D0045-A-500-NNNN	45	120	3 x 160	200	4	< 1	1,2
HMF01.1A-N0K2-D0073-A-500-NNNN	73	160	3 x 100	200	4	< 1	1,2
HMF01.1A-N0K2-D0095-A-500-NNNN	95	190	3 x 78	200	4	< 1	1,2
HMF01.1A-N0K2-D0145-A-500-NNNN	145	220	3 x 50	200	4	< 1	1,2

Fig. 5-37: Electrical data

Motor filter	Cross section [mm <sup>2</sup> ]	Cross section flexible [mm <sup>2</sup> ]	Cross section [AWG]	Tightening torque [Nm]
HMF01.1A-N0K2-D0045-A-500-NNNN	16	-	6	1,5
HMF01.1A-N0K2-D0073-A-500-NNNN	35	-	2	6
HMF01.1A-N0K2-D0095-A-500-NNNN	50	2*25	0	6
HMF01.1A-N0K2-D0145-A-500-NNNN	95	2*50	4/0	25

Fig. 5-38: Terminal connector data

## 6 Mounting and Installation

### 6.1 Mounting

#### Dimensions – Power Sections

##### Device Depths, Heights and Widths

Device	Device width [mm]	Min. mounting width [mm] 1)	Device height [mm] 2)	Device depth [mm] 3)
HCS02.1E-W0012	65	70	290	265 for control cabinets with at least 300 mm of depth
HCS02.1E-W0028	65	70	352	
HCS02.1E-W0054	105	110	352	
HCS02.1E-W0070	105	110	352	
HCS03.1E-W0070	125	125	440	322 for control cabinets with at least 400 mm of depth
HCS03.1E-W0100	225	225	440	
HCS03.1E-W0150	225	225	440	
HCS03.1E-W0210	350	350	440	

- 1) incl. minimum distance between the components
- 2) device body without mounting flange on top and bottom, as well as minimum distances for ventilation and installation
- 3) incl. touch guard, connector housing, bending radius of fiber optic cable, control panel "C"

Fig. 6-1: Mounting dimensions

### Drilling Pattern for the Mounting Plate

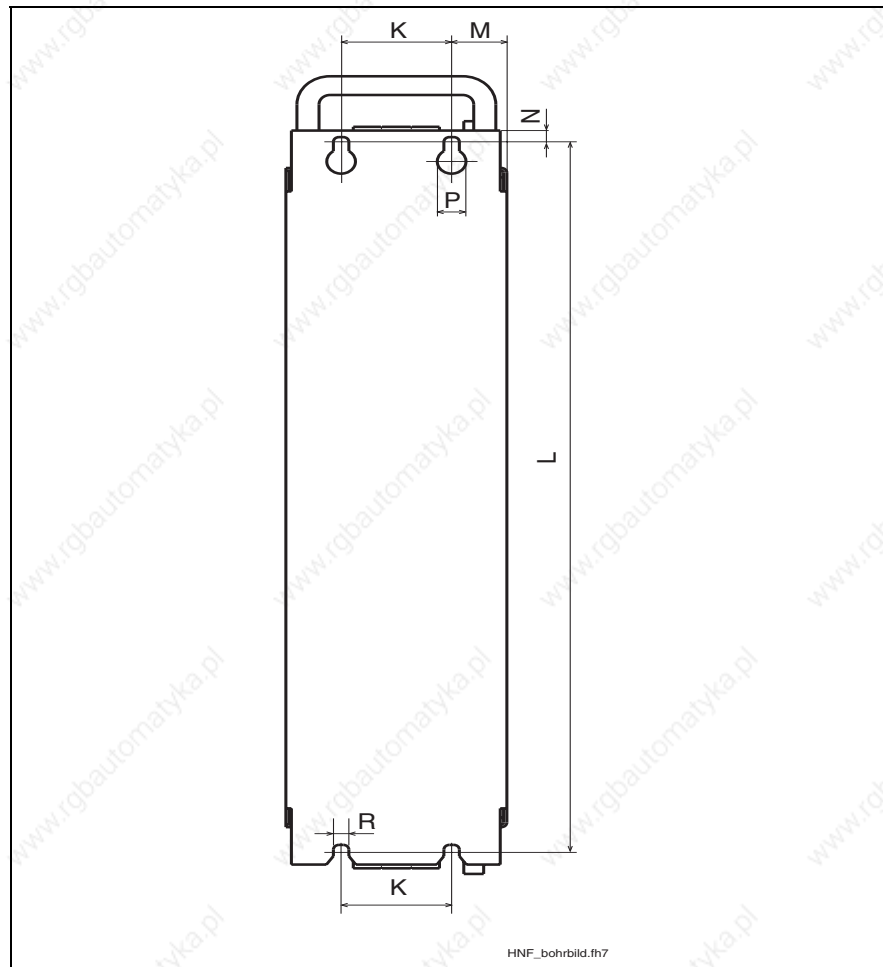

Fig. 6-2: Drilling pattern

**Note:** The figure shows the back of the devices.

Device	K [mm]	L [mm]	M [mm]	P [mm]	R [mm]	Notes
HCS02.1E-W0012	0	316	32,5	13	7	observe additional distance to lateral neighboring devices
HCS02.1E-W0028	0	378	32,5	13	7	observe additional distance to lateral neighboring devices
HCS02.1E-W0054	55	378	25	13	7	observe additional distance to lateral neighboring devices
HCS02.1E-W0070	55	378	25	13	7	observe additional distance to lateral neighboring devices
HCS03.1E-W0070	75	466	25	13	7	
HCS03.1E-W0100	175	466	25	13	7	
HCS03.1E-W0150	175	466	25	13	7	
HCS03.1E-W0210	250	466	50	13	7	
HNL02.1	100	378	20	13	7	

Fig. 6-3: Drilling pattern

### Distances for Drive Controllers

In addition to the mounting dimensions, the components of the Rexroth IndraDrive range require additional mounting clearance

- to ventilate the components
- to mount accessories and connections
- to take temperature limits of neighboring mounting parts, such as cable ducts etc., into account

To determine the required mounting clearances in the control cabinet, take additional distances between the components and on their tops and bottoms into account.

### Distance between Drive Controllers

Owing to power dissipation in the components, especially due to installed braking resistors in compact devices, the temperatures of neighboring components are rising. In the case of lateral mounting, trouble-free operation therefore requires the following minimum distances in [mm] between the components.

from	to	
	HCS02	HCS03 (HNK01, HLR01)
HCS02.1E	5	--
HCS03.1E with HNK01 and HLR01	--	0

-- not allowed

Fig. 6-4: Minimum distance in [mm]

**Note:** For arrangement of the components in the control cabinet, take their dimension sheets and the required minimum distances into account.

### Distances on Top and Bottom of Components

Owing to power dissipation in the components, the temperature of the cooling air current at the device outlet is rising to values higher than ambient temperature at device inlet.



**CAUTION**

**Property damage due to temperatures higher than 105 °C!**

⇒ Comply with indicated minimum distances!

In order that drive controllers can discharge the power dissipation generated inside of them, they need space on their top (A) and bottom (B).

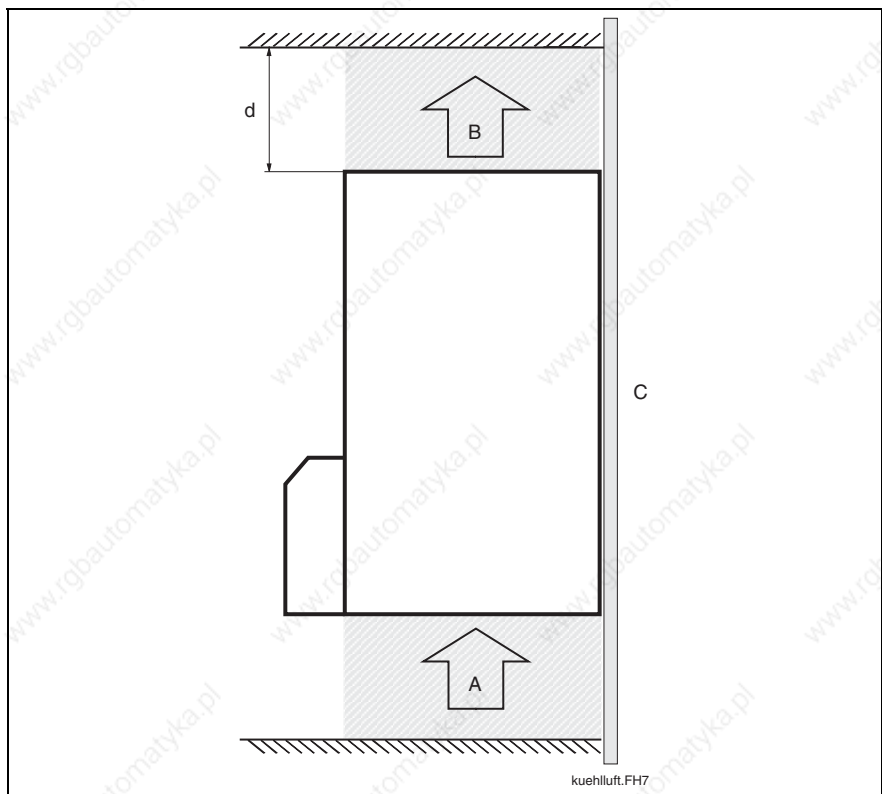

- A: air intake
- B: air outlet
- C: mounting surface in control cabinet
- d: distance to top of device

Fig. 6-5: Air intake and air outlet at drive controller



**Minimum distance for ventilation**

For sufficient ventilation of the components you have to comply with the minimum distances below. At components **without integrated braking resistor**, there will be temperatures of up to 105 °C at the air outlet (B) (with an air intake temperature of 45 °C).

Component	Minimum distance for ventilation		Notes
	at the bottom (A) [mm] 1)	at the top (B) [mm] 2)	
HCS02	80	80	additionally take power at braking resistor into account
HCS03	100	80	

- 1) for additional mounting parts, such as HAS, see dimensional drawings
  - 2) integrated braking resistors require additional distance
- Fig. 6-6: Minimum distance for ventilation

**Note:** If there are different minimum distances for the individual components in a drive system, the greatest value determines the minimum distance to be observed.

**Minimum Distance to Braking Resistor**

For components with integrated braking resistor (supply units, DC bus resistor units, HCS02 drive controllers) their higher outlet temperatures have to be taken into account.

To determine the required distances the resulting outlet temperatures are indicated in diagrams in the technical data of the components.

Input value in the diagrams is the generated power of the braking resistors or the individual output current. See exemplary diagram below:

Input value in the diagrams is the generated power of the braking resistors or the individual output current. See exemplary diagram below:

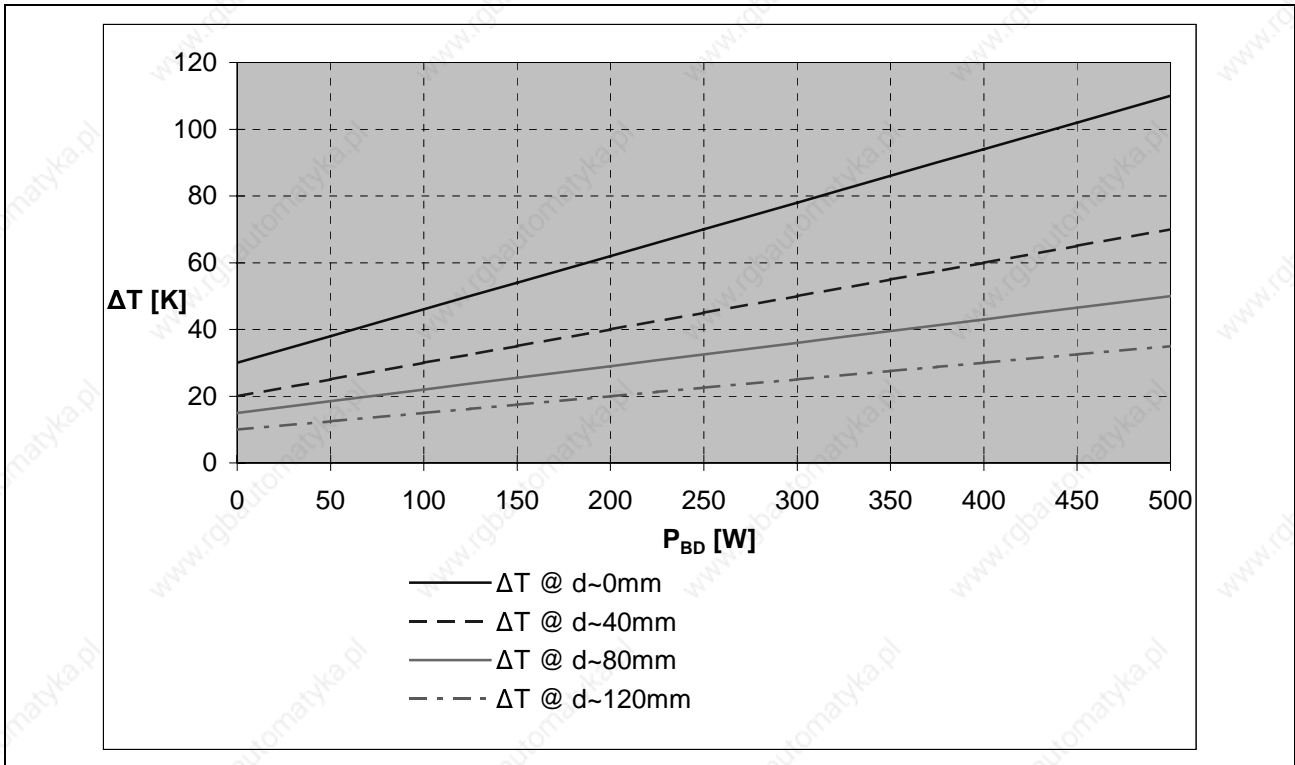

$P_{BD}$ : average continuous braking resistor power  
 $d$ : distance to top of device

Fig. 6-7: Exemplary diagram

The minimum distance for these mounting parts results from the intersection of the input value with the allowed temperature rise.

## Dimensions – Mains Filter HNF

### Drilling Pattern

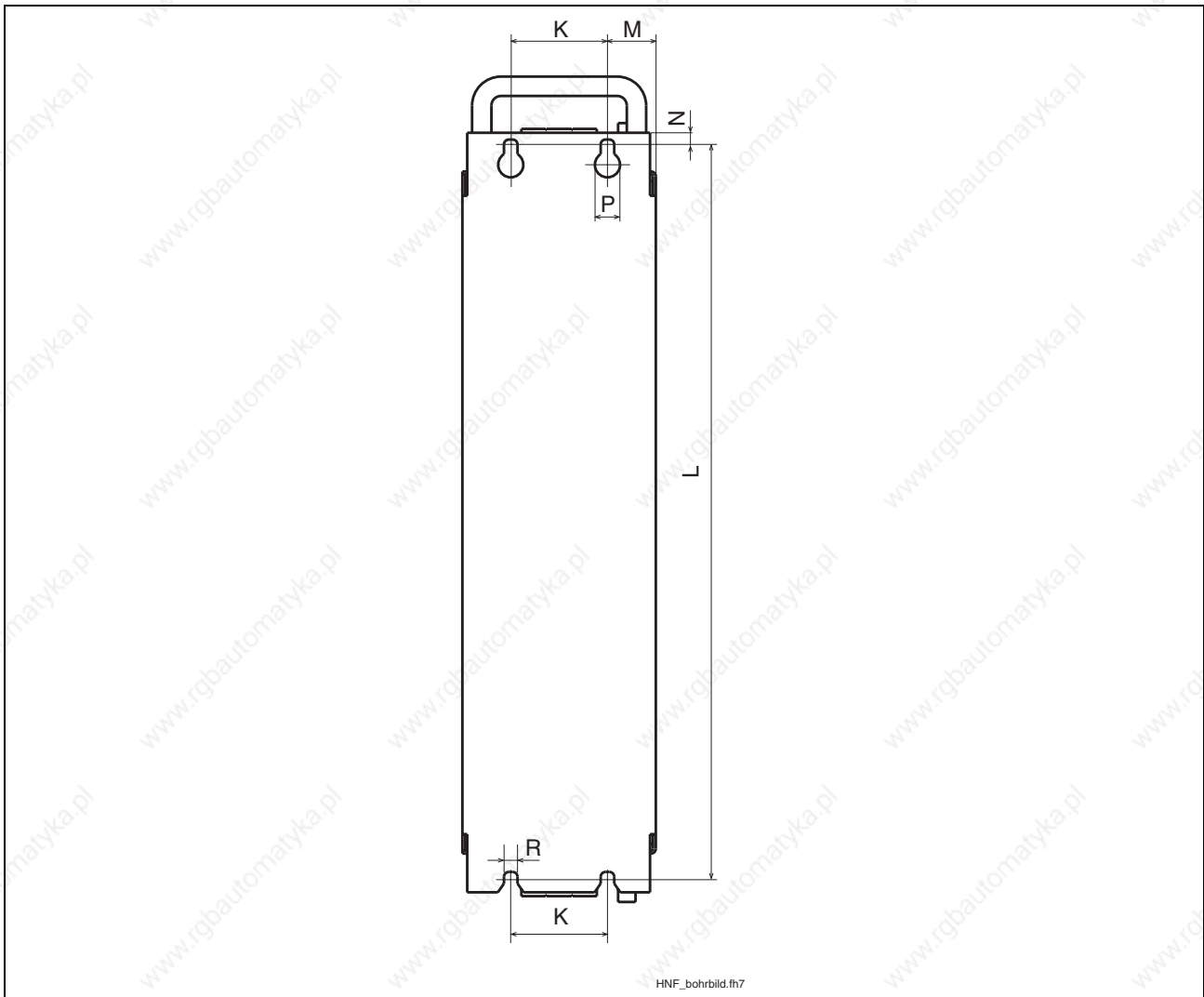

**Note:** The figure shows the back of the devices.

Mains filter	K [mm]	L [mm]	M [mm]	N [mm]	P [mm]	R [mm]
HNF01.1A-F240-E0051-A-480-NNNN HNF01.1A-M900-E0051-A-480-NNNN	50	466	25	7	13	6,5
HNF01.1A-F240-E0125-A-480-NNNN HNF01.1A-M900-E0125-A-480-NNNN	125	466	12,5	7	13	6,5
HNF01.1A-F240-E0202-A-480-NNNN	125	466	12,5	7	13	6,5
HNF01.1A-M900-E0202-A-480-NNNN	150	466	50	7	13	6,5
HNF01.1A-F240-R0026-A-480-NNNN	50	466	25	7	13	6,5
HNF01.1A-M900-R0026-A-480-NNNN	100	466	25	7	13	6,5
HNF01.1A-F240-R0065-A-480-NNNN HNF01.1A-M900-R0065-A-480-NNNN	100	466	25	7	13	6,5
HNF01.1A-F240-R0094-A-480-NNNN HNF01.1A-M900-R0094-A-480-NNNN	125	466	12,5	7	13	6,5

Fig. 6-8: Drilling pattern

Dimensions

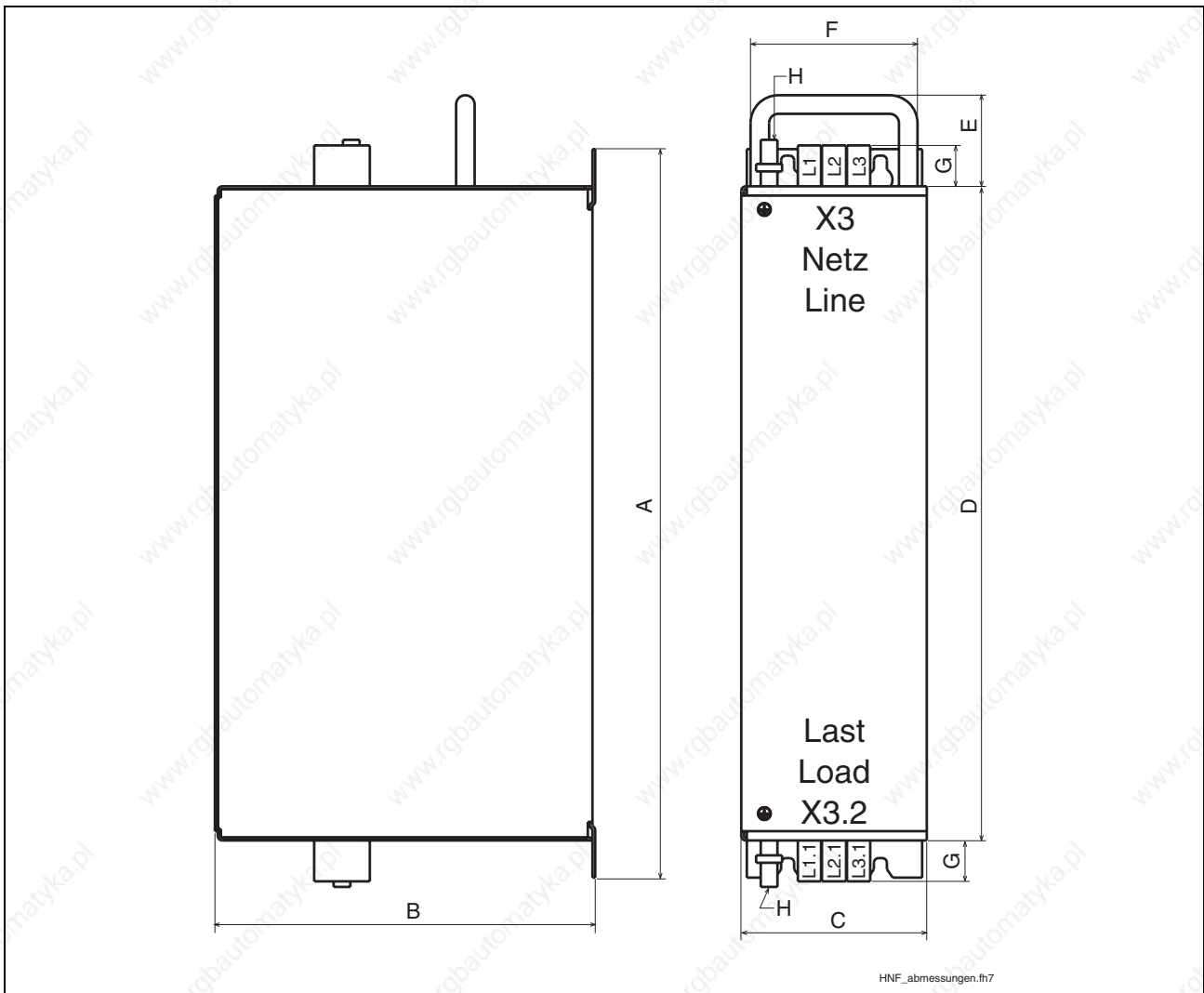

Mains filter	A [mm]	B [mm]	C [mm]	D [mm]	E [mm]	F [mm]	G [mm]	H	max. tightening torque [Nm]
HNF01.1A-F240-R0026-A-480-NNNN	480	262	100	440	-	-	26	M6x20	8.6
HNF01.1A-F240-E0051-A-480-NNNN HNF01.1A-M900-E0051-A-480-NNNN	480	262	100	440	-	-	33	M6x16	2.3
HNF01.1A-M900-R0026-A-480-NNNN	480	262	150	440	-	-	26	M6x20	8.6
HNF01.1A-F240-R0065-A-480-NNNN HNF01.1A-M900-R0065-A-480-NNNN	480	262	150	440	40	110	40	M6x16	4.8
HNF01.1A-F240-R0094-A-480-NNNN HNF01.1A-M900-R0094-A-480-NNNN	480	262	150	440	40	110	45	M10x30	25
HNF01.1A-F240-E0125-A-480-NNNN HNF01.1A-M900-E0125-A-480-NNNN	480	262	150	440	40	110	45	M10x30	25
HNF01.1A-F240-E0202-A-480-NNNN	480	262	150	440	40	110	63.5	M10x30	25
HNF01.1A-M900-E0202-A-480-NNNN	480	262	250	440	40	110	63.5	M10x30	25

Fig. 6-9: Dimensions

### Dimensions – Mains Choke HNL01.1E (infeeding)

Dimensions Type 1:

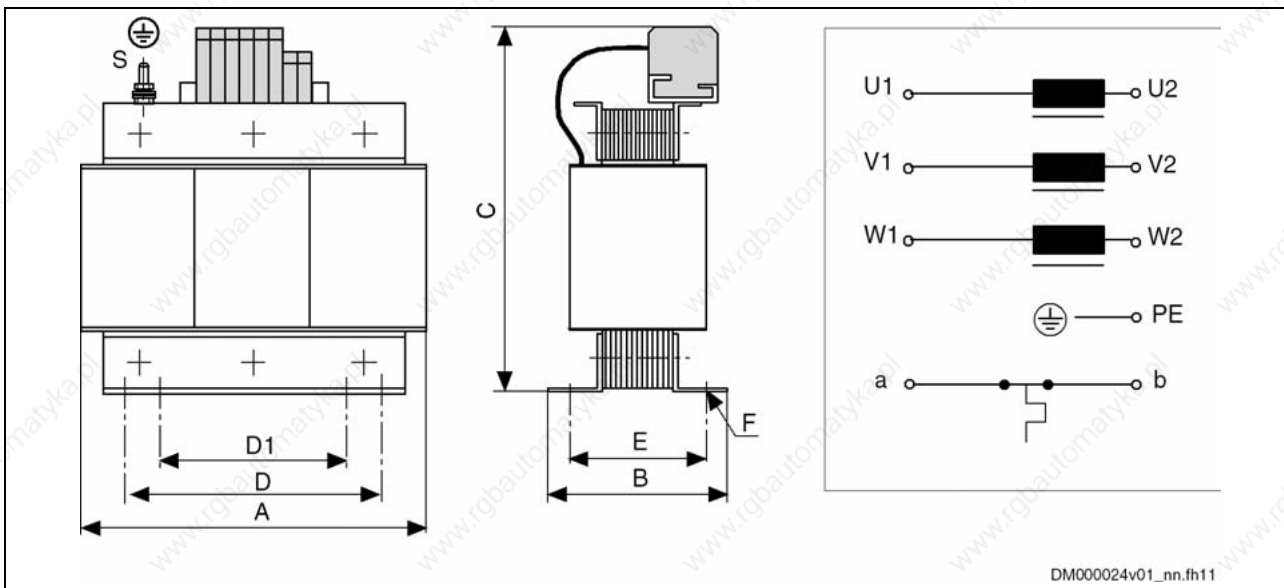

Dimensions Type 2:

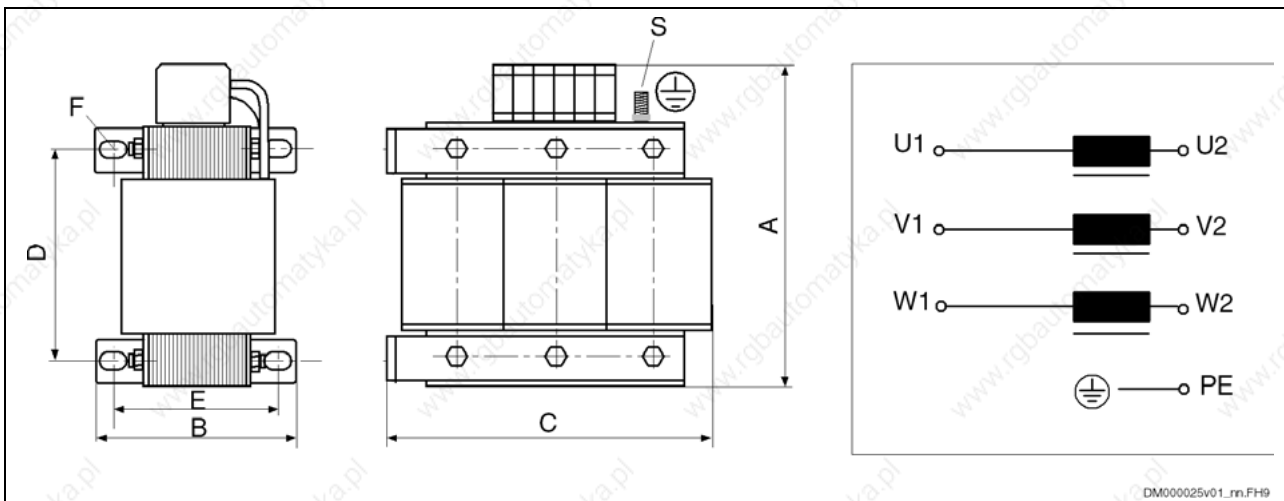

Dimensions Type 3:

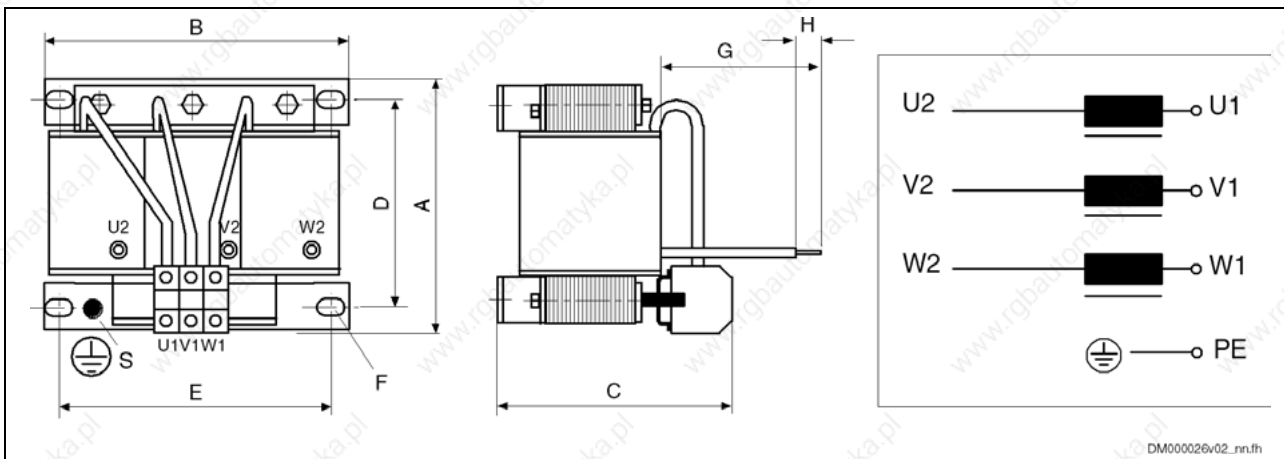

Dimensions Type 4:

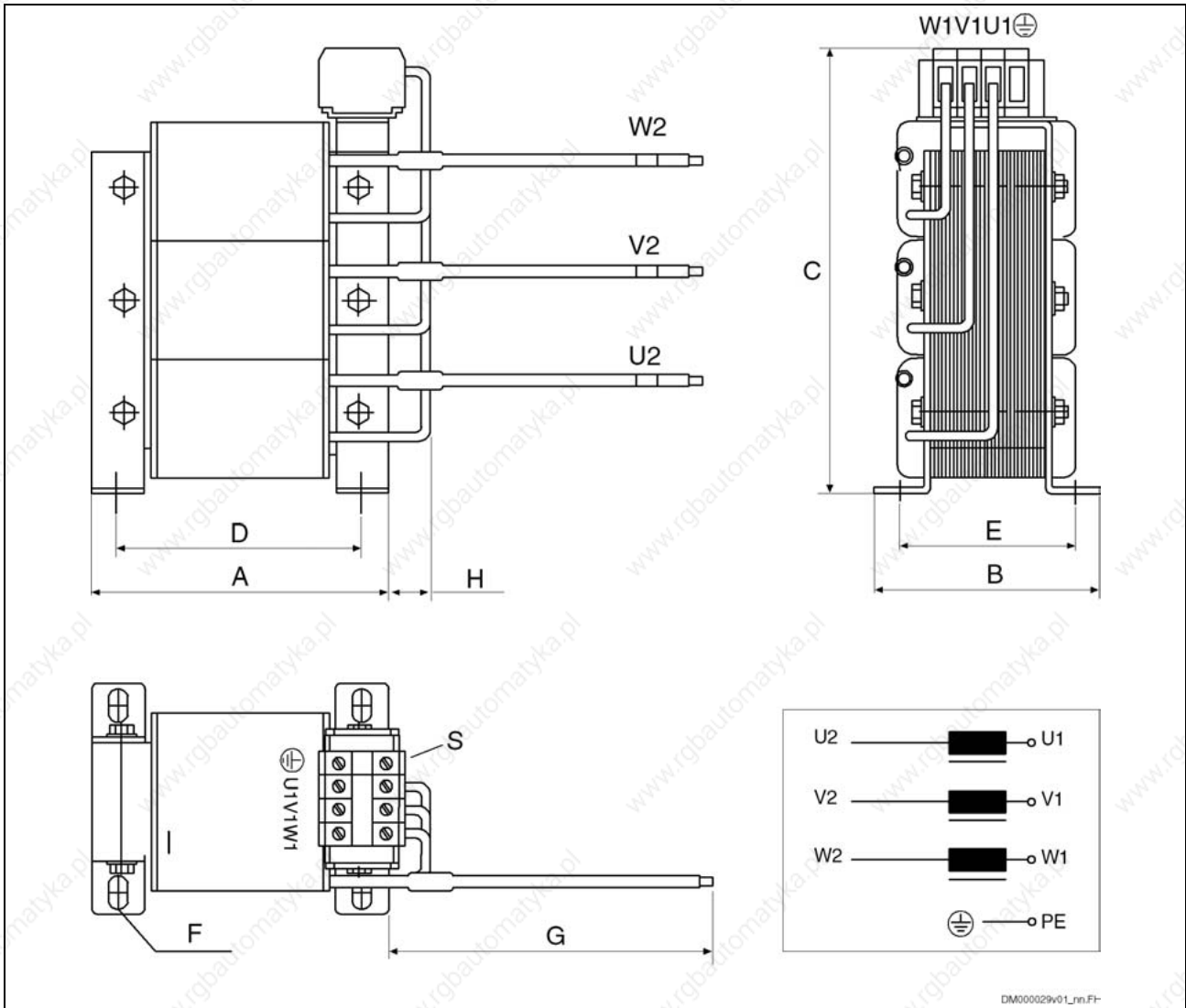

DM000029v01\_enn.FP

Mains choke	Type	Dim. [mm]									Weight [kg]
		A	B	C	D	D1	E	F <sup>1)</sup>	G	H	
HNL01.1E-1000-N0012-A-500-NNNN	1	120	61	164	81	-	44	6,4 x 11			2,7
HNL01.1E-1000-N0020-A-500-NNNN	1	150	66,5	184	113	-	49,5	6,4 x 11			3,8
HNL01.1E-0600-N0032-A-500-NNNN	1	150	66,5	185	113	-	49,5	6,4 x 11			4,5
HNL01.1E-0571-N0050-A-500-NNNN	4	153	100	238	127	-	80	8,5 x 12	400	30	13
HNL01.1E-0400-N0051-A-480-NNNN	1	180	112	225	125	80	87	7 x 15			13,5
HNL01.1E-0362-N0080-A-500-NNNN	3	175	205	180	145	-	185	8,5 x 12	350	ca. 12	13
HNL01.1E-0240-N0106-A-500-NNNN	3	193	205	210	145	-	185	8,5 x 12	380	ca. 12	15
HNL01.1E-0200-N0125-A-480-NNNN	1	230	148	295	180	-	122	8 x 12			24
HNL01.1E-0170-N0146-A-500-NNNN	3	205	250	230	152	-	230	8,5 x 12	400	ca. 12	22
HNL01.1E-0100-N0202-A-480-NNNN	1	265	152	350	215	-	126	15 x 11			33

1) long hole in "B" direction

Fig. 6-10: Mechanical data HNL

Mains Choke	$U_N$ [V]	$I_N$ [A]	$L_N$ [μH]	$P_V$ [W]	$I_{max}$ [A]	$L_{min}$ at $I_{max}$	Connection Cross Section [mm <sup>2</sup> ]
HNL01.1E-1000-N0012-A-500-NNNN	500	12	3 x 1000	40	25	50% of $L_N$	4 (a, b: 4)
HNL01.1E-1000-N0020-A-500-NNNN	500	20	3 x 1000	60	50	50% of $L_N$	6 (a, b: 4)
HNL01.1E-0600-N0032-A-500-NNNN	500	32	3 x 600	75	80	50% of $L_N$	10 (a, b: 4)
HNL01.1E-0571-N0050-A-500-NNNN	500	50	3 x 571	50	100	50% of $L_N$	16 (a, b: -) AWG 8
HNL01.1E-0400-N0051-A-480-NNNN	480	51	3 x 400	165	77	50% of $L_N$	16 (a, b: 2,5)
HNL01.1E-0362-N0080-A-500-NNNN	500	80	3 x 362	80	160	50% of $L_N$	35 (a, b: -) AWG 6
HNL01.1E-0240-N0106-A-500-NNNN	500	106	3 x 240	100	212	50% of $L_N$	35 (a, b: -) AWG 1/0
HNL01.1E-0200-N0125-A-480-NNNN	480	125	3 x 200	170	188	50% of $L_N$	70 (a, b: 2,5)
HNL01.1E-0170-N0146-A-500-NNNN	500	146	3 x 170	130	292	50% of $L_N$	50 (a, b: -) AWG 1/0
HNL01.1E-0100-N0202-A-480-NNNN	480	202	3 x 100	200	303	50% of $L_N$	150 (a, b: 2,5)

Fig. 6-11: Electrical data HNL

### Temperature Contact a, b

**Switching Capacity** 1 A / AC 250 V; DC 24 V

**Switching Temperature** 125 °C

---

**Note:** HNL01.1E mains chokes of type 1 are equipped with a temperature contact (a, b), types 2, 3 and 4 are not.

---

## Dimensions – Standard Braking Resistors HLR01.1

**Note:** The standard braking resistors are intended to be mounted above the drive controllers HCS03; otherwise, forced convection (blower) with a volume stream of 200 m<sup>3</sup>/hour is to be provided.

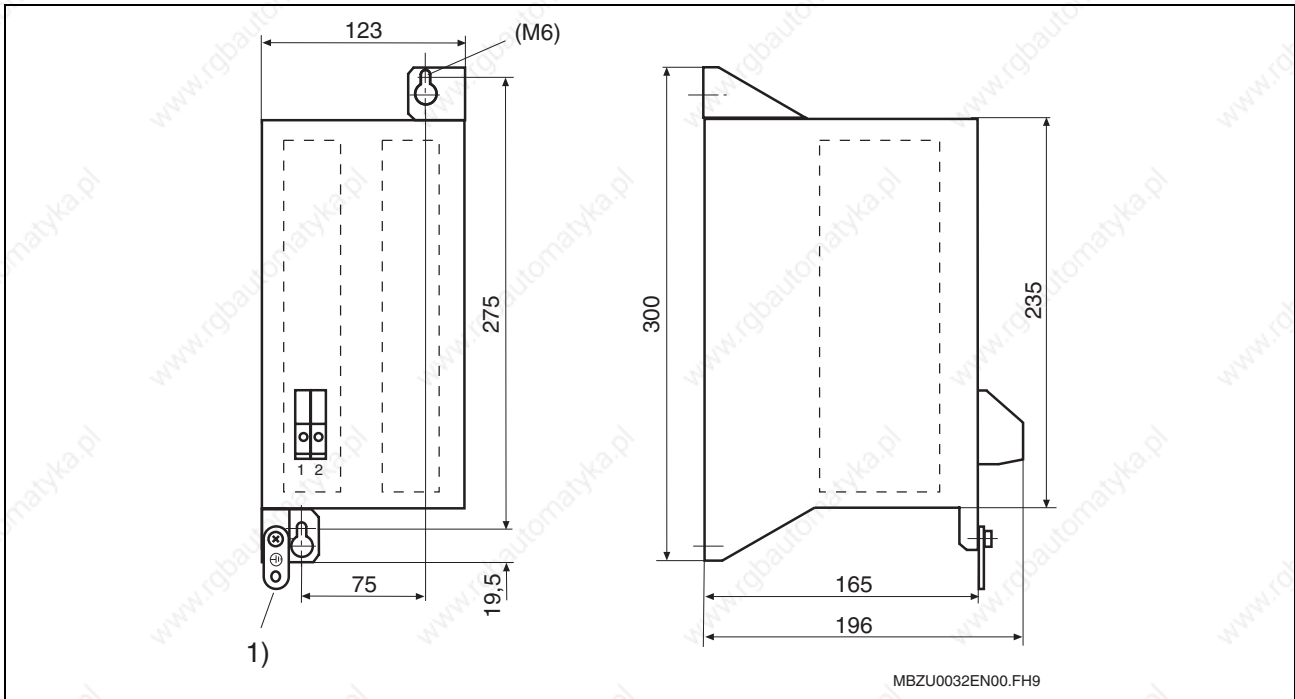

Fig. 6-12: Dimensional drawing braking resistor HLR01.1N-0300-N17R5-A-007-NNNN



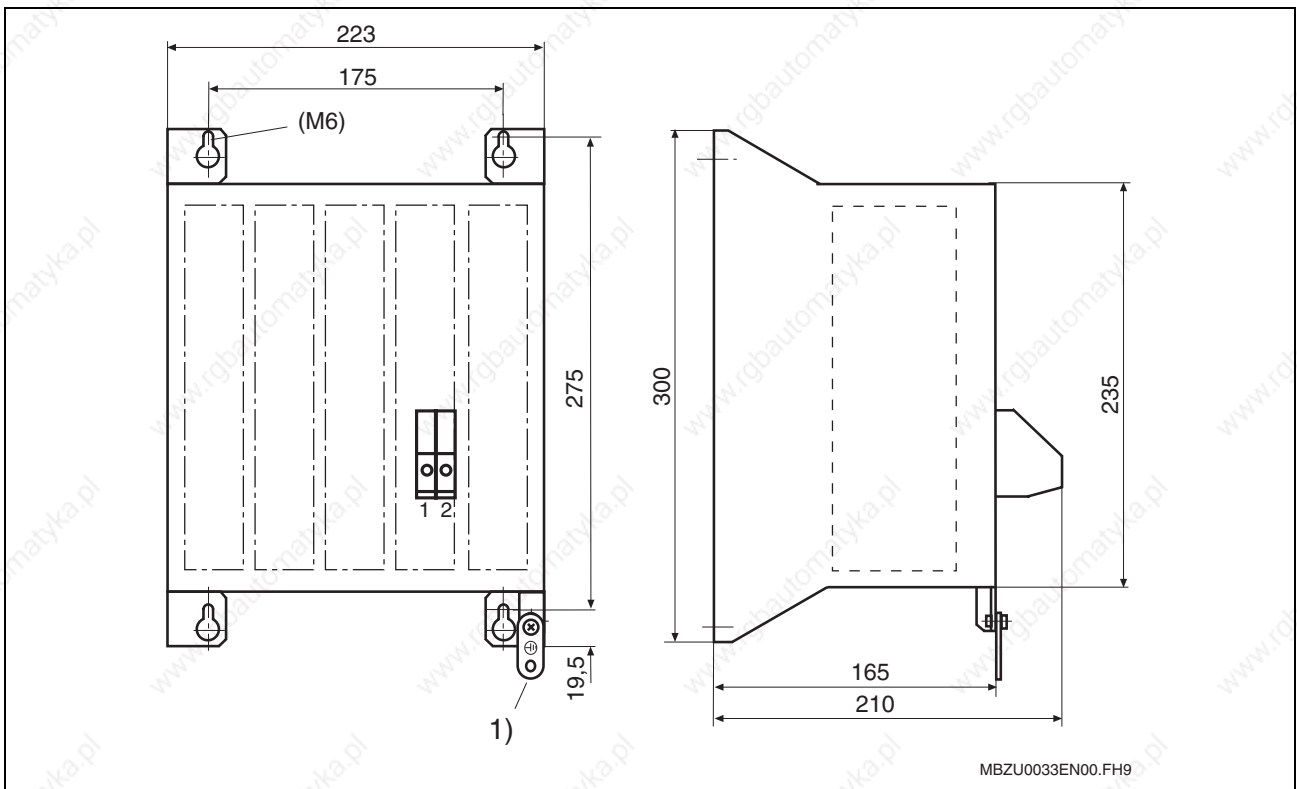

Fig. 6-13: Dimensional drawing braking resistor HLR01.1N-0470-N11R7-A-007-NNNN and HLR01.1N-0780-N07R0-A-007-NNNN

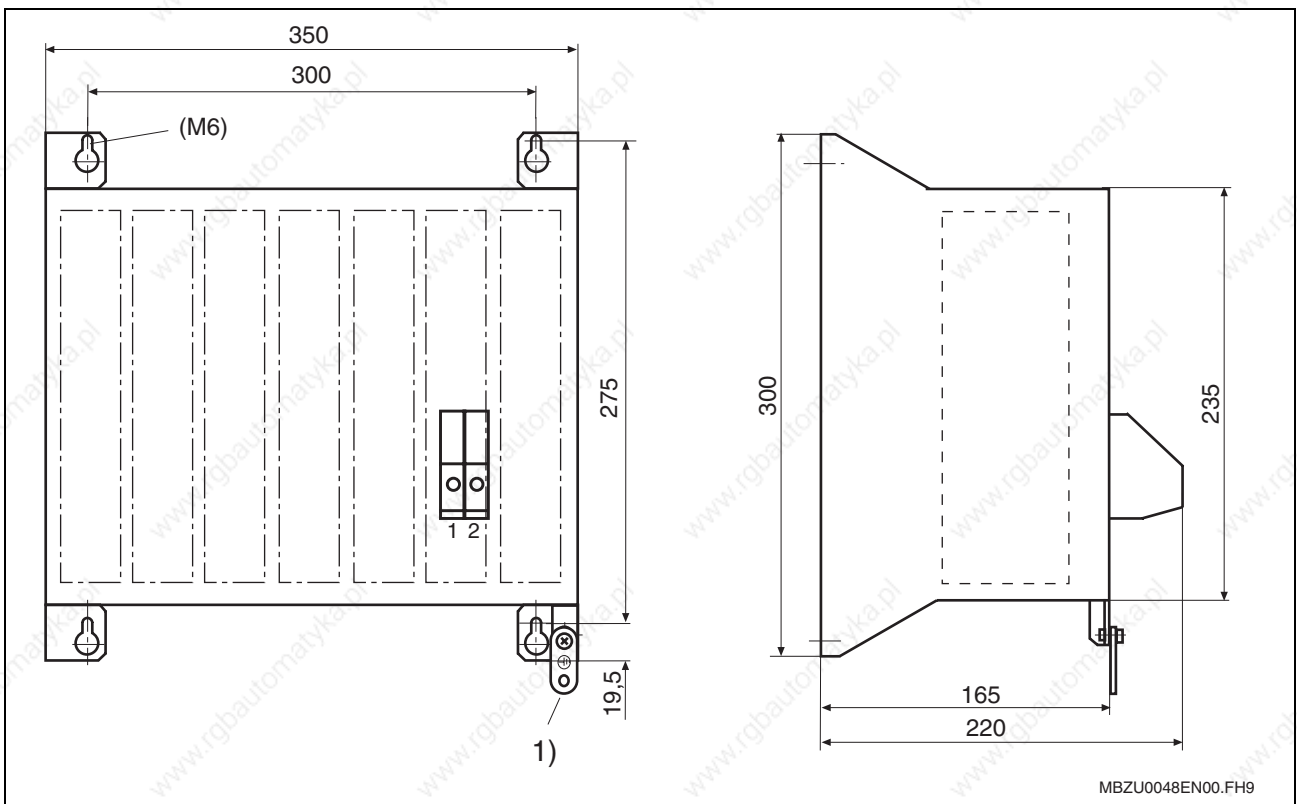

Fig. 6-14: Dimensional drawing braking resistor HLR01.1N-1K08-N05R0-A-007-NNNN

**Note:** The joint bar (ground strap) is contained in the scope of supply of the standard braking resistors HLR01.

## Dimensions – Reinforced Braking Resistors HLR01.1

### Fixed Resistors IP 20 Type A

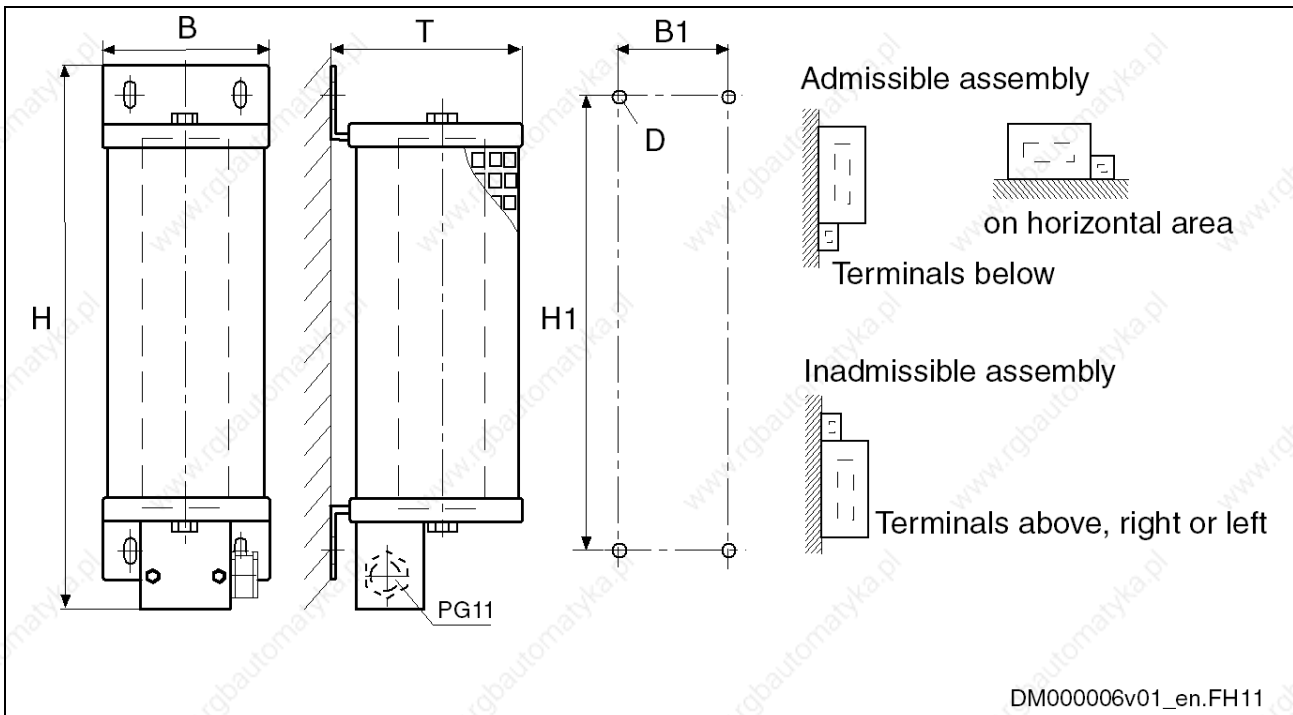

Fig. 6-15: Type A5 – A6

Type	Dimensions in mm						Weight in kg
	H	B	T	H1	B1	D	
A5	586	185	120	526	150	M6	5,2
A6	686	185	120	626	150	M6	6,2

Fig. 6-16: Dimensions table braking resistor type A

**Steel Grid Fixed Resistors IP 20 Type B**

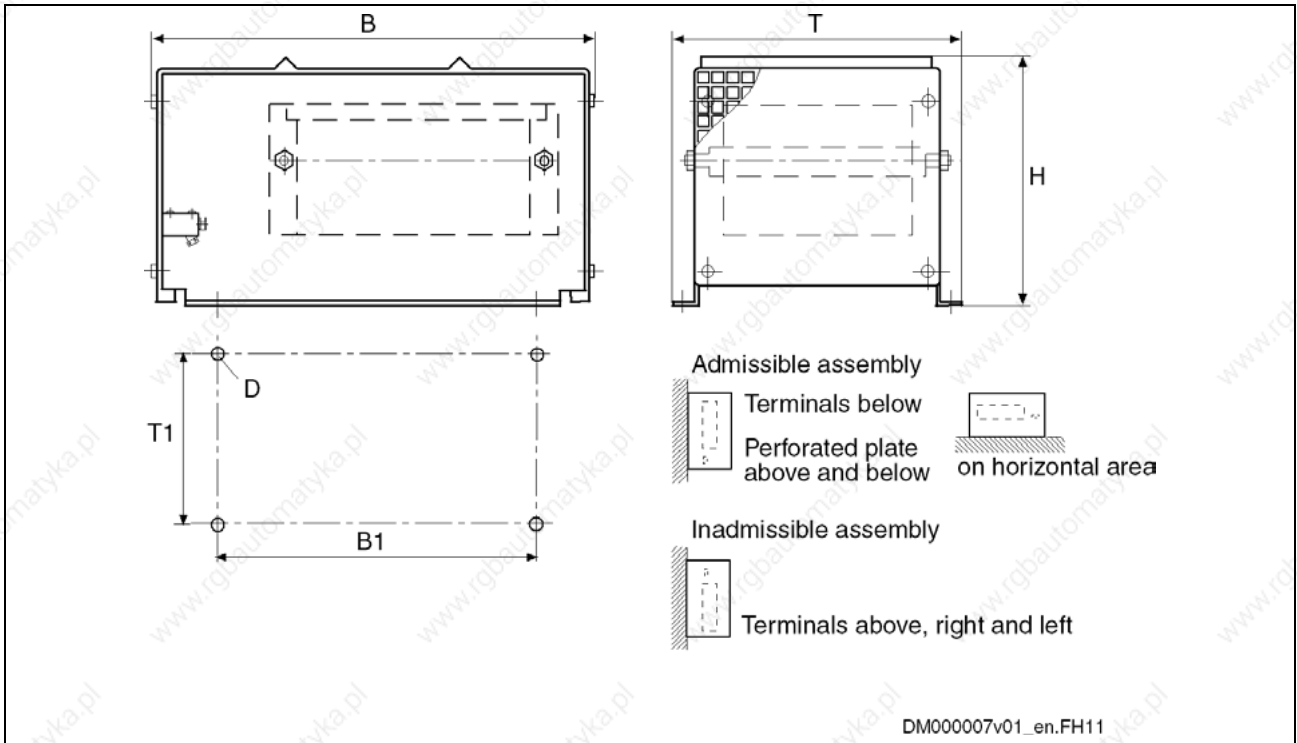

Fig.: 6-17 Type B1 – B4

Type	Dimensions in mm						Weight in kg
	B	T	H	B1	T1	D	
B1	490	300	270	380	270	M10	9,5
B2	490	400	270	380	370	M10	13
B3	490	600	270	380	570	M10	22
B4	490	800	270	380	770	M10	33
B5	490	1000	270	380	970	M10	44

Tab.: 6-1 Dimensions table braking resistor type B

Steel Grid Fixed Resistors IP 20 Type C

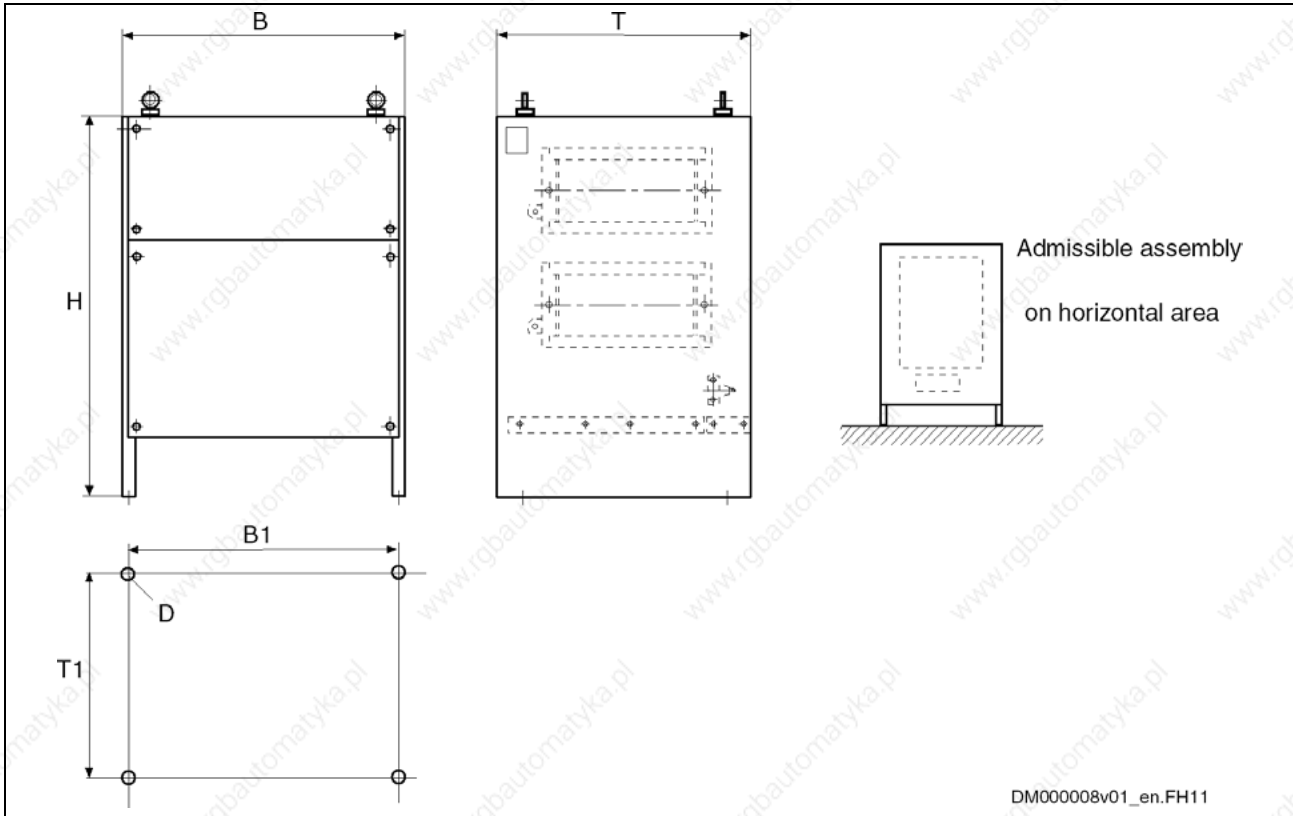

Fig.: 6-18 Type C1 - C7

Type	Dimensions in mm						Weight in kg
	B	T	H	B1	T1	D	
C2	595	490	710	570	380	M10	56
C3	795	490	710	770	380	M10	80
C4	995	490	710	970	380	M10	93

Tab.: 6-2 Dimensions table braking resistor type C

**Note:** Under consideration of the technical data for the minimum braking resistance and the brake chopper, other braking resistors can be used alternatively.

### Dimensions – Motor Filter HMF

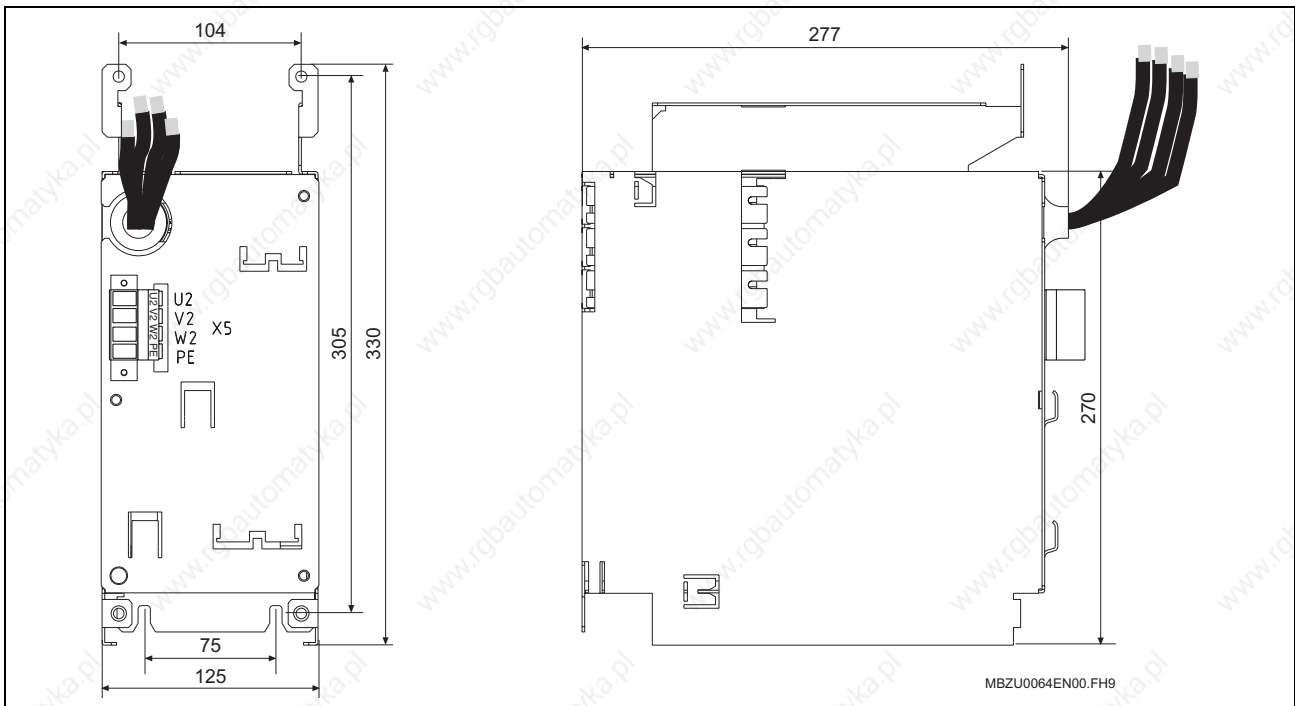

Fig. 6-19: Dimensions motor filter HMF01.1A-N0K2-D0045-A-500-NNNN

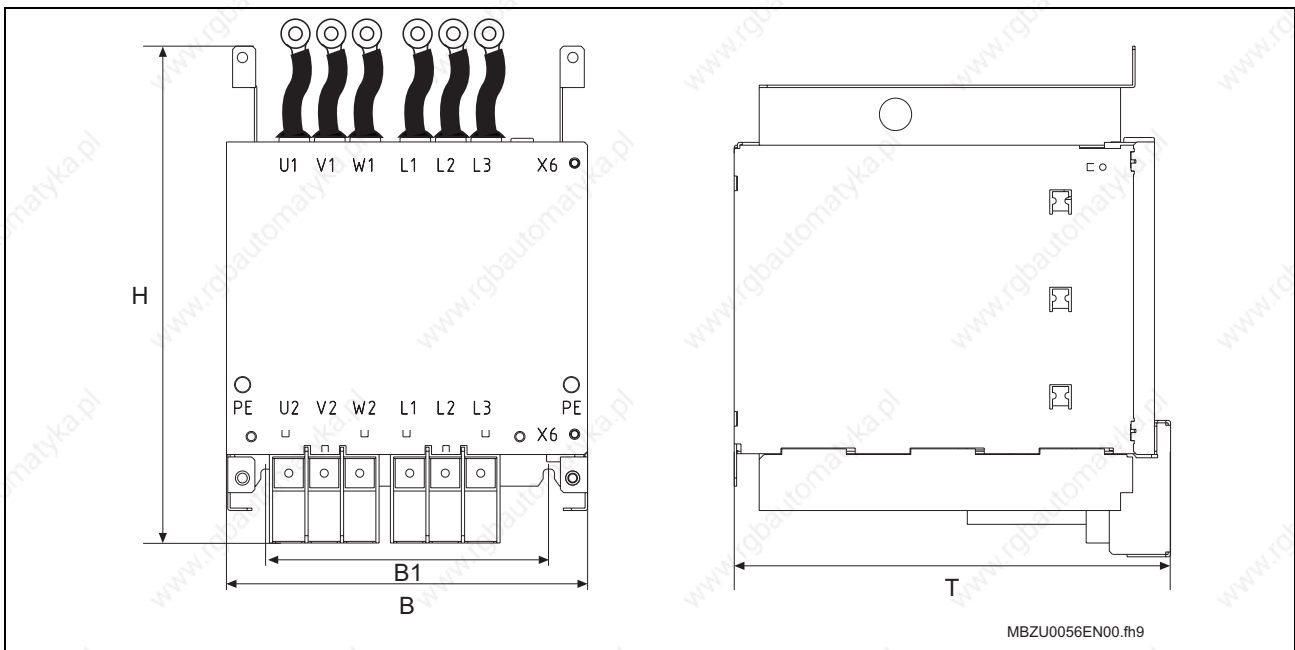

Fig. 6-20: Dimensions motor filter HMF01.1A-N0K2-D0073-A-500-NNNN, HMF01.1A-N0K2-D0095-A-500-NNNN and HMF01.1A-N0K2-D0145-A-500-NNNN

Type	Dimensions in mm				
	B	H	T	B1	H1
0073	225	315	270	175	257
0095	225	315	270	175	257
0145	350	400	260	250	310

Fig. 6-21: Dimensions motor filter

### Arrangement of the Components HCS03.1 / Motor Filter HMF

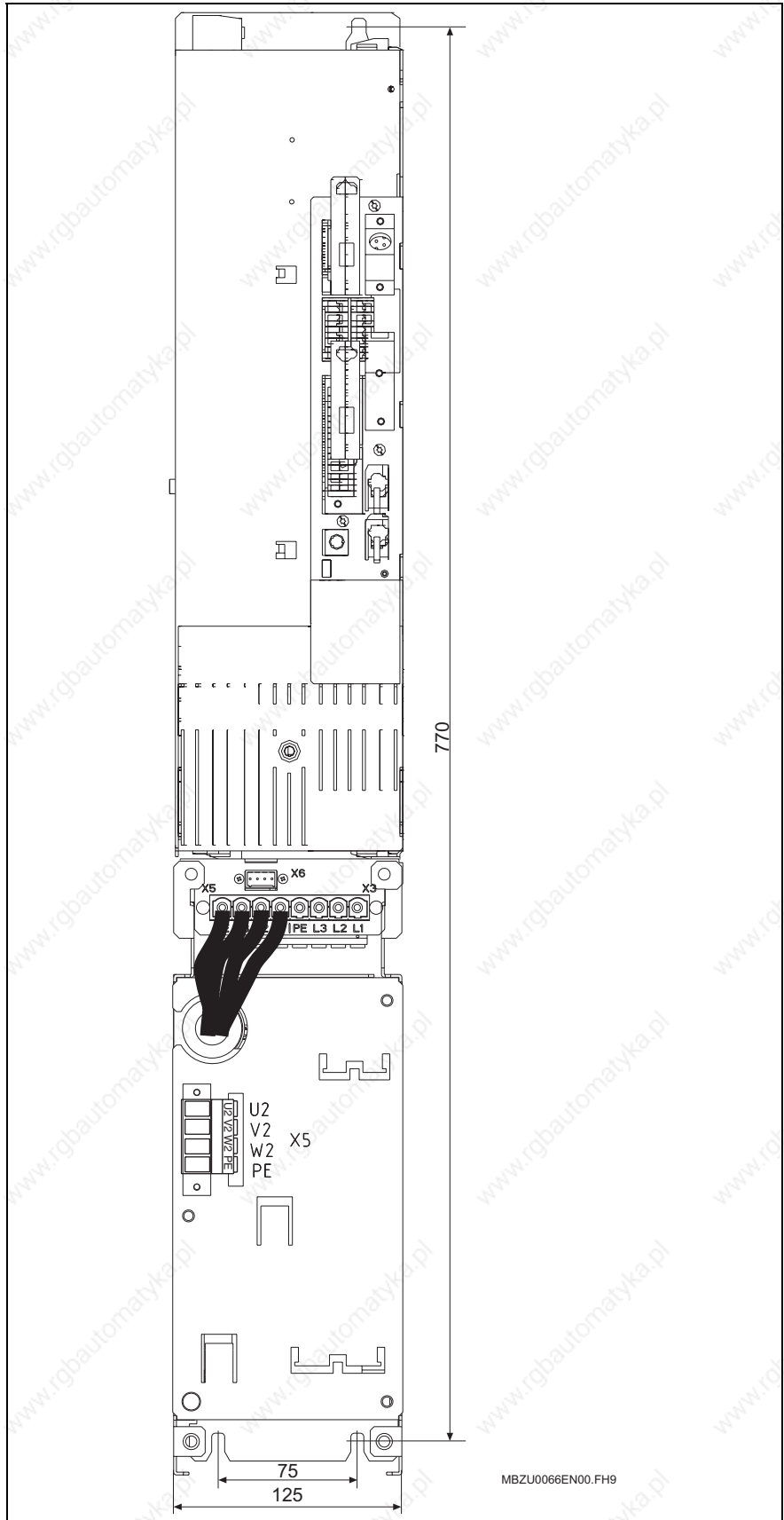

Fig. 6-22: Sample mounting HCS03.1E-W0070 / HMF01.1A-N0K2-D0045

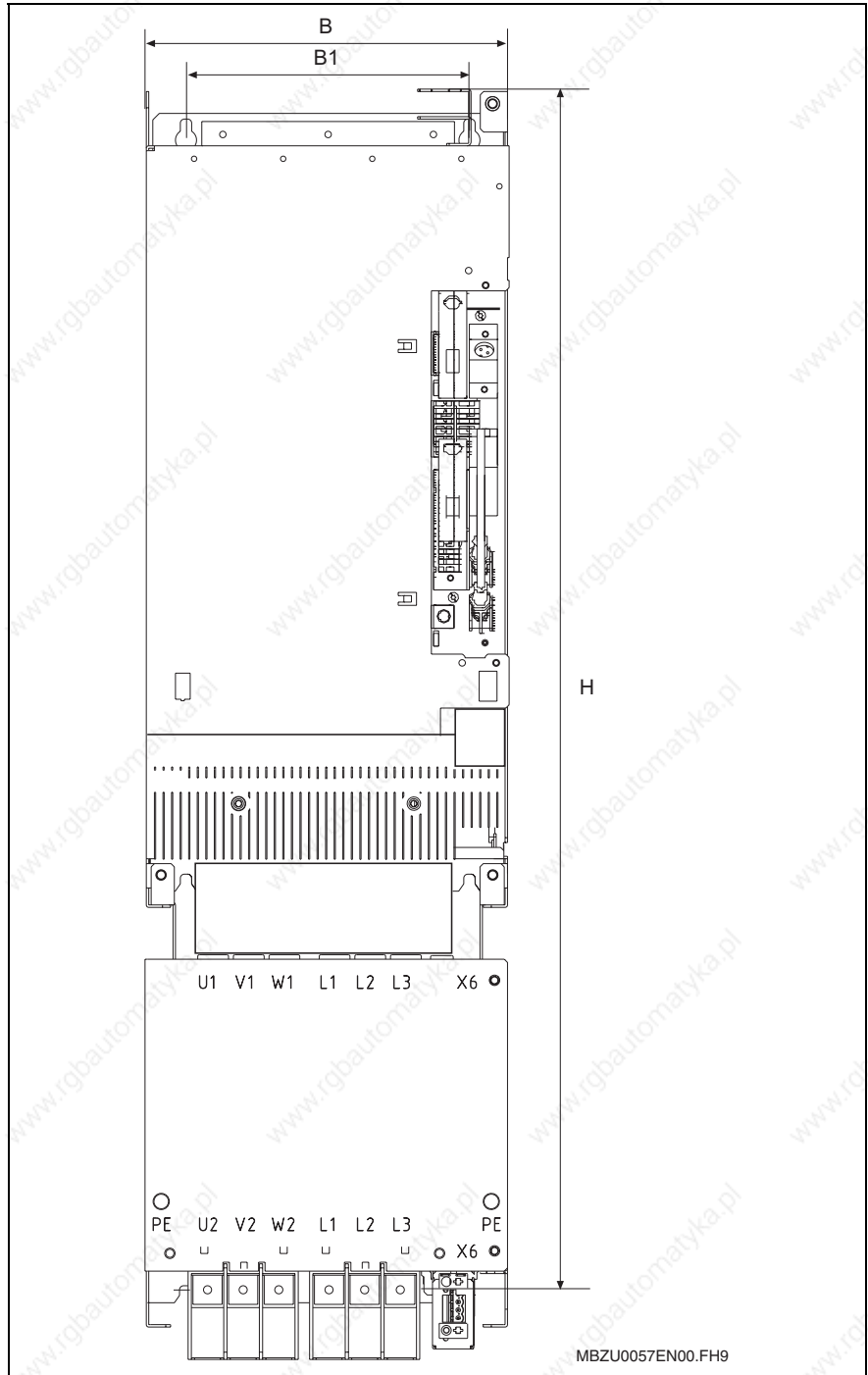

Fig. 6-23: Sample mounting HCS03.1E-W0100 0150 0210 / motor filter

HCS03.1E-	H	B	B1
W0100	720	225	175
W0150	720	225	175
W0210	780	350	250

Fig. 6-24: Dimensions table for sample mounting HCS03.1E-.../ motor filter HMF

### Arrangement of the Components HCS03.1 / Motor Filter and Mains Filter

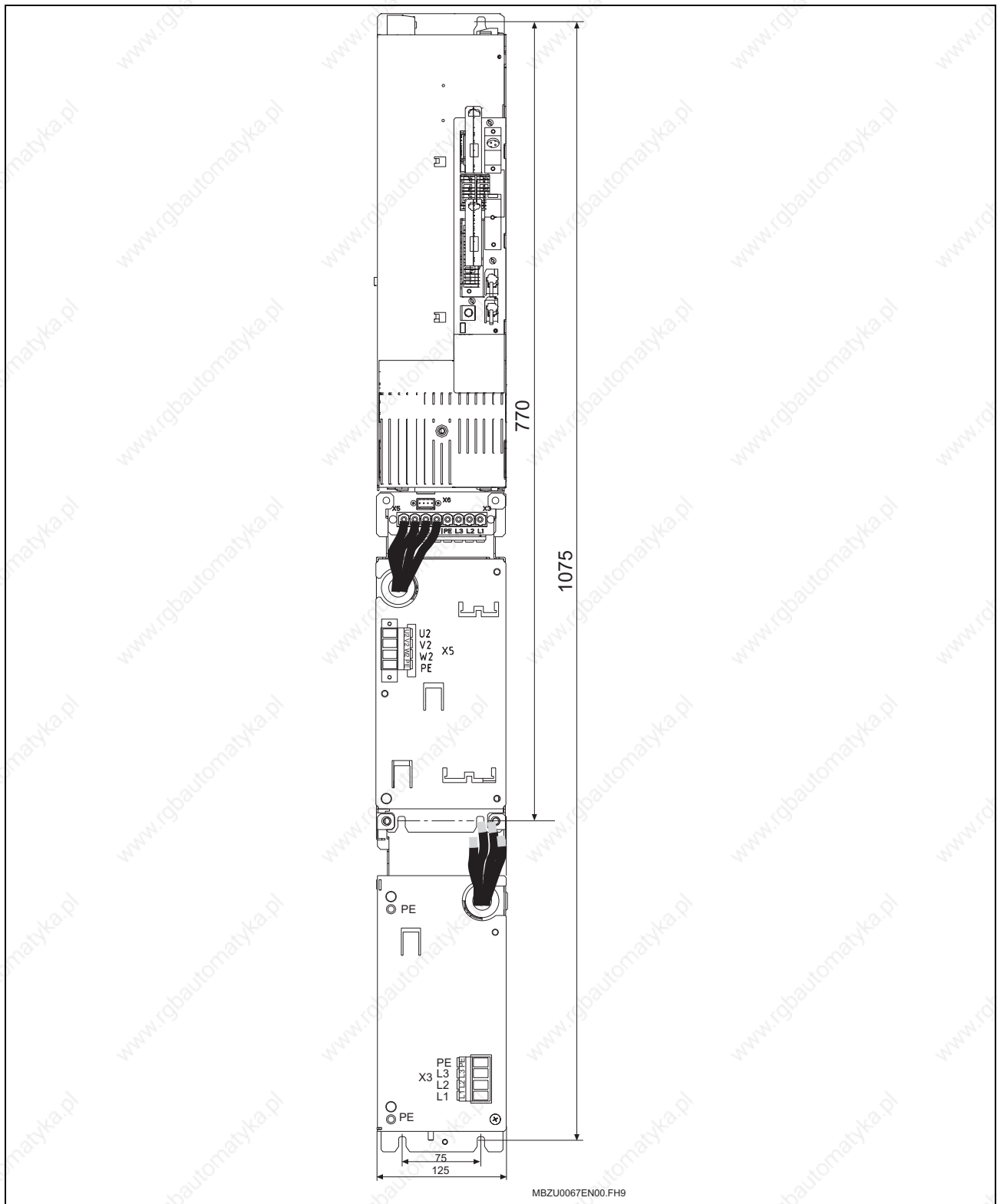

Fig. 6-25: Arrangement HCS03.1E-W0070 / motor filter and mains filter + HAS05.1-001 + HAS05.1-002



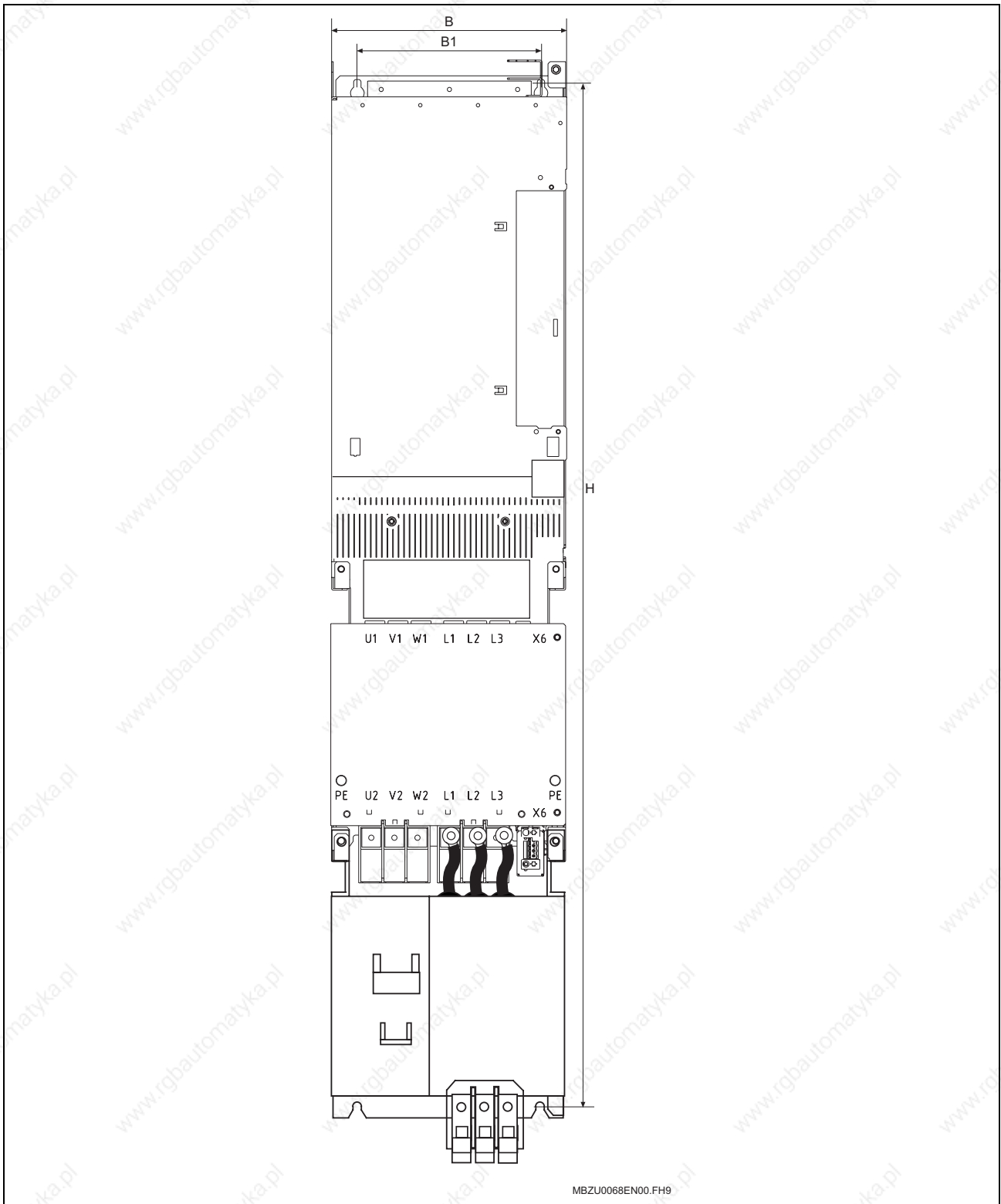

Fig. 6-26: Arrangement of device 0100, 0150, 0210 / motor filter and mains filter

HCS03.1E-	H	B1	B
W0100	980	175	225
W0150	980	175	225
W0210	1090	250	350

Fig. 6-27: Dimensions table for sample mounting HCS03.1E... / mains filter / motor filter

## Combination of Drive Controllers of the Rexroth IndraDrive C Product Range

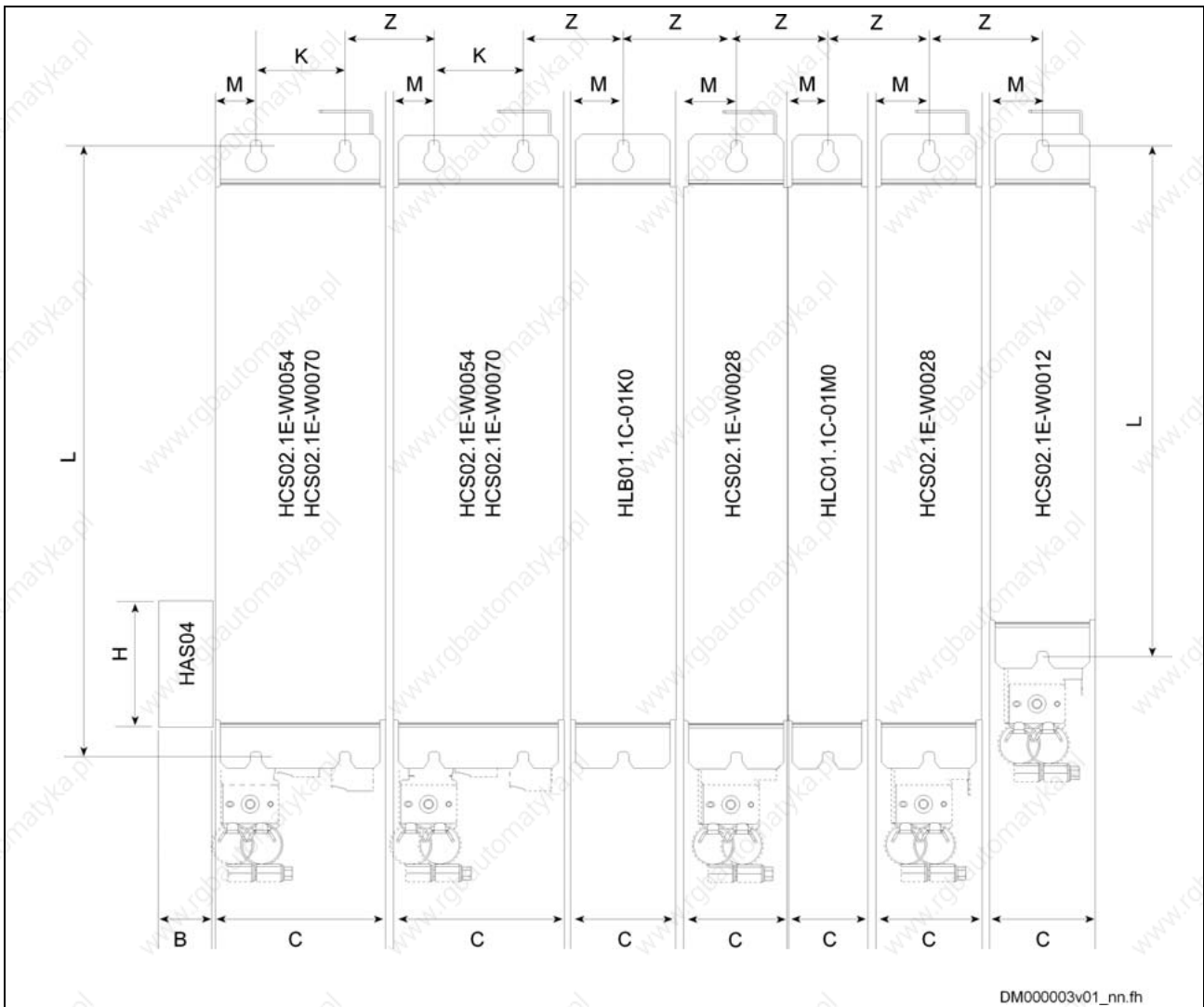

Fig. 6-28: Rexroth IndraDrive C components

**Note:** Observe that using **HAS04** accessory at the HCS arranged at the utmost left position requires additional space of 30 mm.

Rexroth IndraDrive components are arranged in line **to the right** starting from the supplying device. Arrange the drive controllers with high capacity as close to the supplying unit as possible.

The **HAS02** accessories in the figure require additional mounting clearance.

**Dimension Z** is significantly determined by the involved components. The table below contains the dimensions Z between the component arranged to the left and the component arranged to the right.

Component left	Component right	Dimension Z [mm]
HCS02.1E-W0012 HCS02.1E-W0028	HCS02.1E-W0012 HCS02.1E-W0028	70
HCS02.1E-W0054 HCS02.1E-W0070	HCS02.1E-W0054 HCS02.1E-W0070	55
HCS02.1E-W0054 HCS02.1E-W0070		50 (without distance between the components)
HCS02.1E-W0012 HCS02.1E-W0028		57,5 (without distance between the components)
HCS02.1E-W0054 HCS02.1E-W0070	HCS02.1E-W0012 HCS02.1E-W0028	62,5
HCS03.1E-W0070 HCS03.1E-W0100 HCS03.1E-W0150	HCS03.1E-W0070 HCS03.1E-W0100 HCS03.1E-W0150	50 (without distance between the components)
HCS03.1E-W0210	HCS03.1E-W0210	100 (without distance between the components)
HCS03.1E-W0070 HCS03.1E-W0100 HCS03.1E-W0150	HCS03.1E-W0210	75 (without distance between the components)
HCS03.1E-W0210	HCS03.1E-W0070 HCS03.1E-W0100 HCS03.1E-W0150	75 (without distance between the components)

Fig. 6-29: Table for dimension Z

## Multiple-Line Arrangement of Drive Controllers

### Control Cabinet with Multiple-Line Structure

**Note:** Particular attention should be paid to the maximum allowed air intake temperature of components when they are arranged in multiple lines in the control cabinet. Where necessary, cooling air guides are to be provided with blowers specially used for this purpose.

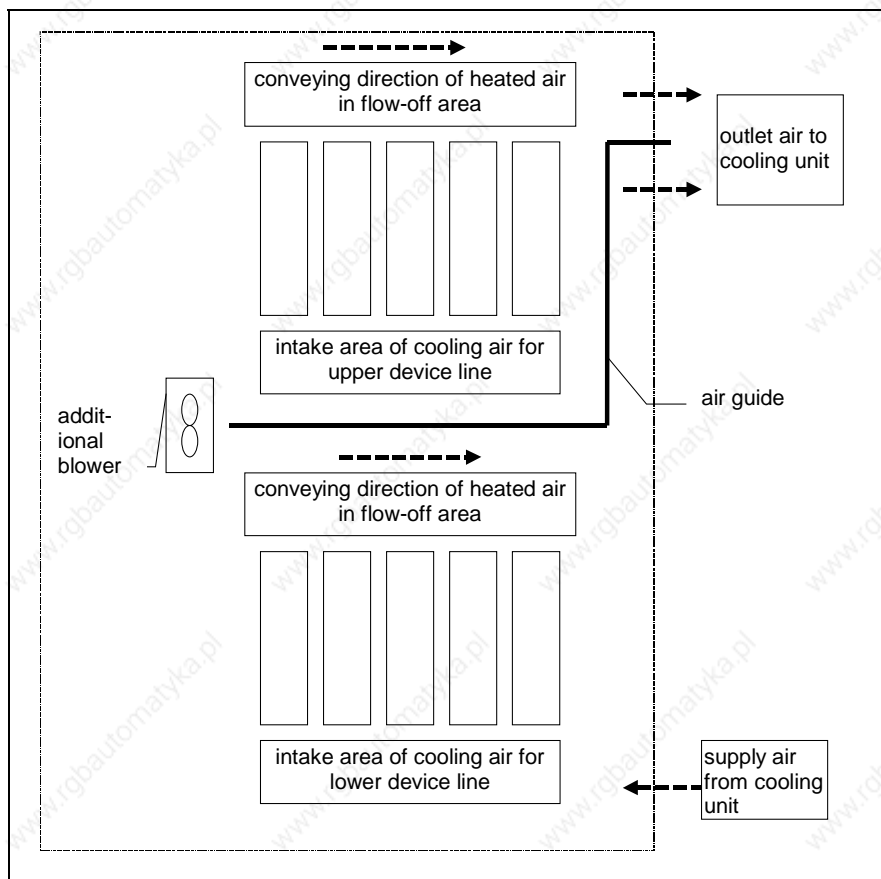

Fig. 6-30: Example of arrangement for multiple-line structure with components

## 6.2 Electrical Installation

---

**Note:** For successful project planning of the electrical installation with regard to EMC, also observe the Project Planning Manual on the drive system Rexroth IndraDrive. The explanations below will help you detect and remove malfunction.

---

### Rules for Design of Installations with Drive Controllers in Compliance with EMC

The following rules are the basics for designing and installing drives in compliance with EMC.

<b>Mains Filter</b>	Correctly use a mains filter recommended by Rexroth for radio interference suppression in the supply feeder of the AC drive system.
<b>Control Cabinet Grounding</b>	All metal parts of the cabinet have to be connected with one another over the largest possible surface area to establish a good electrical connection. This, too, applies to the mounting of the EMC filter. If required, use serrated washers which cut through the paint surface. The cabinet door should be connected to the cabinet using the shortest possible grounding straps.
<b>Line Routing</b>	Avoid coupling routes between lines with high potential of noise and noise-free lines, therefore signal, mains and motor lines and power cables have to be routed separately from another (this eliminates mutual interference!). Minimum clearance: 10 cm. Provide separating sheets between power and signal lines. Separating sheets have to be grounded at several points.  Lines with high potential of noise at the drive controller are lines for the mains supply (incl. mains synchronization), lines at the motor connection and DC bus connections.  Generally, interference injection are reduced by routing cables close to grounded sheet steel panels. For this reason, cables and wires should not be routed freely in the cabinet, but close to the cabinet housing or mounting panels. The incoming and outgoing cables of the radio interference suppression filter have to be separated.
<b>Interference Suppression Elements</b>	Contactors, relays, solenoid valves, electromechanical operating hour counters etc. in the control cabinet must be provided with interference suppression combinations. These combinations must be connected directly at each coil.
<b>Twisted Wires</b>	Non-shielded cables belonging to the same circuit (feeder and return cable) have to be twisted or the surface between feeder and return cable has to be kept as small as possible. Ground cables that are not used at both ends.
<b>Lines of Measuring Systems</b>	Lines of measuring systems have to be shielded. The shield has to be connected to ground at both ends and over the largest possible surface area. The shield may not be interrupted, e.g. using intermediate terminals.
<b>Digital Signal Lines</b>	The shields of digital signal lines have to be grounded at both ends (transmitter <b>and</b> receiver) over the largest possible surface area and with low impedance. Bad ground connection between transmitter and receiver requires additional routing of a bonding conductor (min. 10 mm <sup>2</sup> ). Braided shields are to be preferred to foil shields.
<b>Analog Signal Lines</b>	The shields of analog signal lines generally have to be grounded at one end (transmitter <b>or</b> receiver) over the largest possible surface area and

**Connection of Mains Choke to Drive Controller**

with low impedance, in order to avoid low-frequency interference current (in the mains frequency range) on the shield.

Keep connection lines of mains chokes as short as possible and twist them.

**Installation of Motor Power Cable**

- Preferably use the motor power cables with shield provided by Rexroth. If you use other motor power cables, they have to be run in shielded form.

- Keep length of motor power cable as short as possible.

- Ground shield of motor cable at both ends over the largest possible surface area to establish a good electrical connection.

- Run motor lines in shielded form inside the control cabinet.

- Do not use any steel-shielded lines.

- The shield of the motor cable mustn't be interrupted by mounted components, such as output chokes, sine filters, motor filters.

**EMC-Optimal Installation in Facility and Control Cabinet**

With regard to EMC-optimal installation, a spatial separation of the interference-free area (mains connection) and the interference-susceptible area (drive components) is recommended, as shown in the figures below.

---

**Note:** For EMC-optimal installation in the control cabinet use a separate control cabinet panel for the drive components.

---

**Division into Areas (Zones)**

The arrangement in the control cabinet can be seen from Fig. 6-31.

There are three areas to be distinguished:

1. Interference-free area of control section (area A):

This includes:

- supply feeder, input terminals, fuse, main switch, mains side of mains filter for drives and corresponding connecting lines

- control voltage or auxiliary voltage connection with power supply unit, fuse and other parts unless connection is run via the mains filter of the AC drives

- all components that aren't electrically connected with the drive system

2. Interference-susceptible area (area B):

- mains connections between drive system and mains filter for drives, mains contactor

- interface lines of drive controller

3. Strongly interference-susceptible area (area C):

- motor cable including single strands

Never run lines of one of these areas in parallel with lines of another area so that there isn't any unwanted interference injection from one area to the other and that the filter is jumpered with regard to high frequency. Keep connection lines as short as possible.

For complex systems it is recommended to put the drive components into a cabinet and the controls into a separate second cabinet.

Badly grounded control cabinet doors act as antennas. It is recommended to connect the doors to the control section on top, in the middle and on the bottom via short equipment grounding conductors with a cross section of at least 6 mm<sup>2</sup> or, even better, via grounding straps with the same cross section. Make sure connection points have good contact.

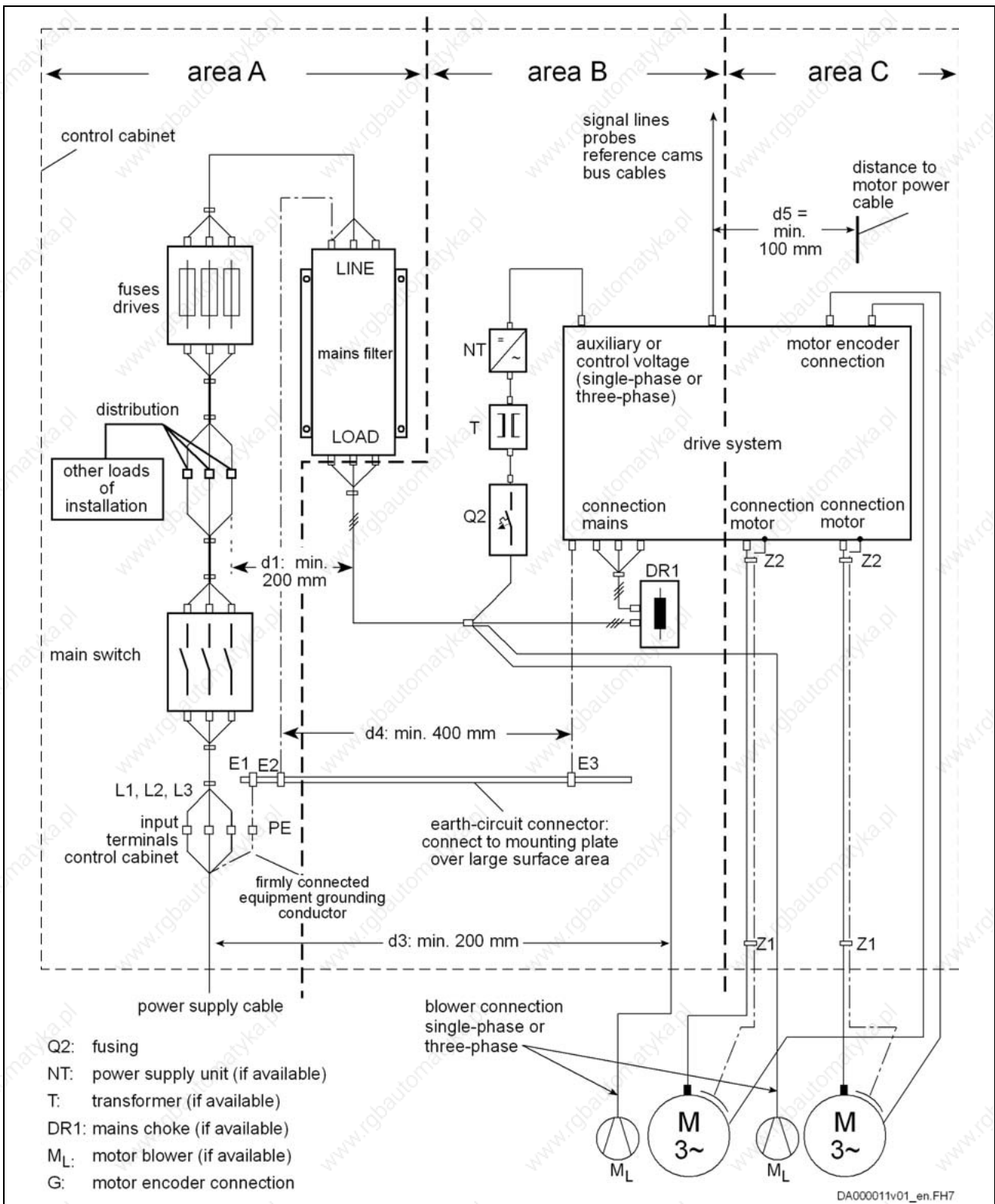

Fig. 6-31: Separation of interference-free area and interference-susceptible area in control cabinet

## Design and Installation in Interference-Free Area of Control Cabinet (Area A)

### Arranging the Components in the Control Cabinet

When arranging the components in the control cabinet, it is recommended that you place the components and electrical elements (switches, pushbuttons, fuses, terminal connectors) in the interference-free zone A with a distance of at least  $d_1 = 200$  mm to the components in both other zones B and C.

In particular, a distance of at least  $d_2 = 500$  mm has to be kept in zone A between magnetic components, such as transformers, line reactors and DC-link reactors, that are directly connected to the power terminals of the drive system and the interference-free components and lines between supply system and filter including the mains filter. If this distance is not kept, the magnetic leakage fields are injected to the interference-free components and lines connected to the mains so that the limit values at the supply connection are exceeded in spite of the installed filter.

### Cable Routing of the Interference-Free Lines to the Mains Connection

The distance between the power input line and the lines between filter and exit point from the control cabinet in area A and the lines in areas B and C must be at least 200 mm (distances  $d_1$  and  $d_3$  in the figure) at all points.

If this is impossible, there are two alternatives:

- Install these lines with a shield and connect the shield, at several points, but at least at the beginning and at the end of the line, to the mounting plate or the control cabinet housing over a large surface area, or:
- Separate these lines from the other interference-susceptible lines in zones B and C by means of a grounded distance plate vertically attached to the mounting plate.

In addition, these lines have to be kept as short as possible within the control cabinet and installed directly on the grounded metal surface of the mounting plate or of the control cabinet housing.

Mains supply lines from zones B and C must not be connected to the mains without a filter.

---

**Note:** In case the information on cable routing given in this section is not observed, the effect of the mains filter is totally or partly neutralized. You must therefore expect the noise level of the interference emission to be higher within the range of 150 kHz to 40 MHz and the limit values at the connection points of the machine or installation to be exceeded.

---

### Routing and Connecting a Neutral Conductor (N)

If a neutral conductor is used together with a three-phase connection, it must not be installed unfiltered in zones B and C, in order to keep interference off the mains.

### Connecting Motor Blowers

Single-phase or three-phase supply lines of motor ventilators, that are usually routed in parallel with motor cables or interference-susceptible lines, also have to be provided with a filter. They either have to be filtered via a separate single-phase filter (NFE type) or three-phase filter (HNF, NFD type) near the supply connection of the control cabinet, or to be connected at the load side of the existing three-phase filter for the power connector of the drive system. When switching power off, make sure the ventilator is not switched off.



**Shielding Mains Supply Lines in Control Cabinet**

If there is a high degree of interference injection to the power input line within the control cabinet, in spite of you having observed the above instructions (to be found out by standard EMC measurement), the lines in area A have to be routed in shielded form. In this case the shields have to be connected to the mounting plate at the beginning and the end of the line by means of clips. The same procedure may be required for long cables of more than 2 m between the point of power supply connection of the control cabinet and the filter within the control cabinet.

**Mains Filters for AC Drives**

The mains filter ideally should be mounted on the parting line between area A and B. Make sure the ground connection between filter housing and housing of the drive controllers has good electrically conductive properties. If single-phase loads are connected on the load side of the filter, their current may only be a maximum of 10% of the three-phase operating current. A highly imbalanced load of the filter would deteriorate its interference suppression capacity.

If the mains voltage is more than 480 V, the filter has to be connected on the output side of the transformer and not on its supply side.

**Grounding**

In the case of bad ground connections in the installation, the distance between the lines to the grounding points E1, E2 in area A and the other grounding points of the drive system should be at least  $d_4 = 400 \text{ mm}$ , in order to minimize interference injection from ground and ground cables to the power input lines.

**Point of Connection for Equipment Grounding Conductor of Machine, Installation, Control Cabinet**

The equipment grounding conductor of the power cable of the machine, installation or control cabinet of the has to be **firmly connected** at point PE and have a **cross section of at least  $10 \text{ mm}^2$**  or to be complemented by a second equipment grounding conductor via separate terminal connectors (according to EN50178/ 1997, section 5.3.2.1). If the cross section of the outer conductor is bigger, the cross section of the equipment grounding conductor has to be adjusted accordingly.

**Design and Installation in Interference-Susceptible Area of Control Cabinet (Area B)****Arranging Components and Lines**

Modules, components and lines in area B should be placed at a distance of at least  $d_1 = 200 \text{ mm}$  from modules and lines in area A or shielded by distance plates mounted vertically on the mounting plate. As an alternative, the lines can be shielded.

Power supply units for auxiliary or control voltage connections in the drive system mustn't be directly connected to the mains, but have to be connected to the mains via a mains filter, as indicated in Fig. 6-31.

Keep line length between drive controller and filter as short as possible. Avoid unnecessary lengths.

**Control Voltage or Auxiliary Voltage Connection**

Only in exceptional cases should a connection of power supply unit and fusing for the control voltage connection be made at phase and neutral conductor. In this case these components have to be mounted and installed in area A, far away from the areas B and C of the drive system. For details see chapter "Design and Installation in Interference-Free Area of Control Cabinet (Area A)".

The connection between control voltage connection of the drive system and power supply unit used has to be run through area B over the shortest distance.

**Line Routing**

Run the lines along grounded metal surfaces, in order to minimize radiation of interference fields to area A (transmitting antenna effect).

### Design and Installation in Strongly Interference-Susceptible Area of Control Cabinet (Area C)

Area C mainly concerns the motor cables, especially at the connection point at the device.

#### Influence of the Motor Power Cable

The discharge capacitance is limited to ensure compliance with the limit values. The calculation of the discharge capacitance can be found in the "Calculations" chapter.

If the applications allows this, the cable length should always be kept short. Avoid unnecessary line lengths.

#### Routing the Motor Cables

The motor cables have to be run in shielded form. Besides they are always to be routed with a distance of  $d_5 = 100 \text{ mm}$  to the other interference-free lines and to signal cables and lines, or to be separated from them by a grounded distance plate. The latter is not required for the feedback cables of Rexroth motors.

At the drive controller connection the motor cables and the (unfiltered) power connection lines may only be routed in parallel for a distance of 300 mm. After that distance, motor cables and power supply cables have to be routed in opposite directions in separate cables ducts, as illustrated in the following figures (Fig. 6-32; Fig. 6-33) by the example of a drive system with separate mains connection per drive axis IndraDrive HCS.

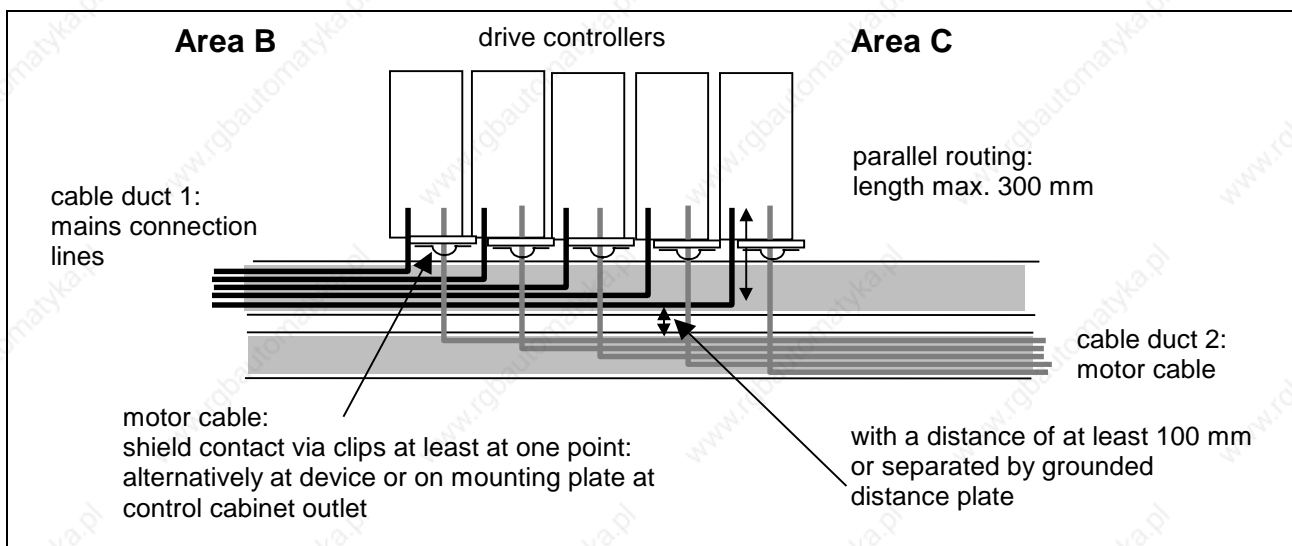

Fig. 6-32: Option 1: separate routing of motor cable and mains connection lines via 2 cable ducts

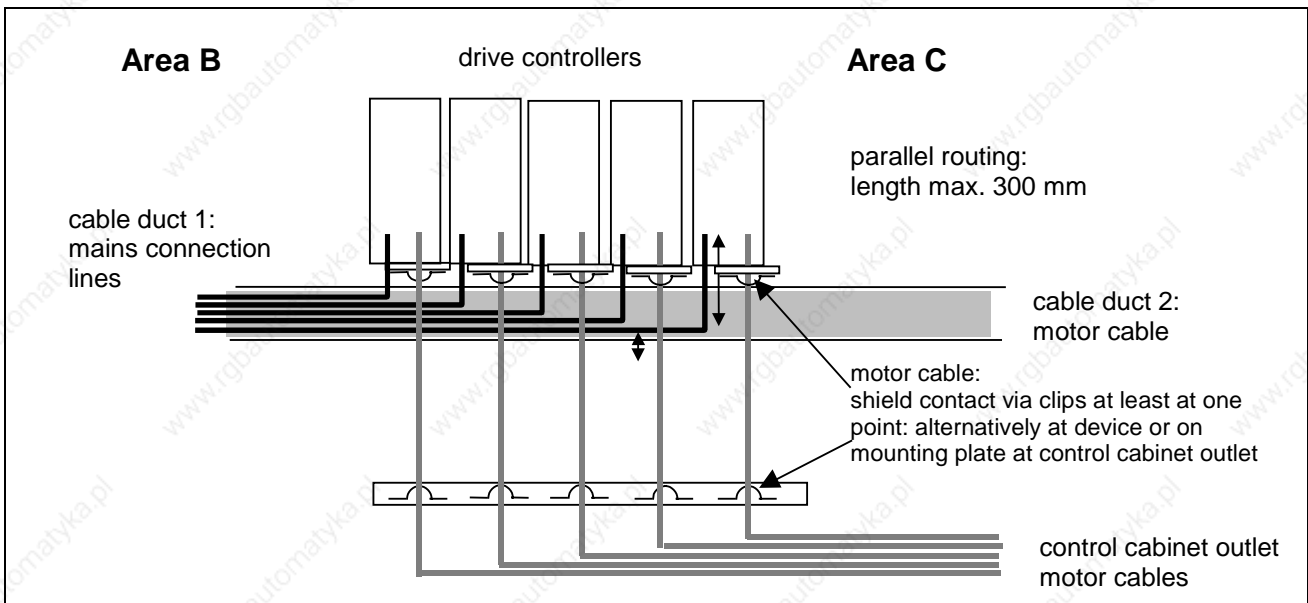

Fig. 6-33: Option 2: separate routing of motor cable and mains connection lines

**Additional Recommendations on Cable Routing**

The motor cables should be routed along grounded metal surfaces, both inside the control cabinet and outside of it, in order to minimize radiation of interference fields. If possible the motor cables should be routed in metal-grounded cable ducts.

The outlet of the motor cables at the control cabinet should ideally be provided in a distance of at least  $d_3 = 200 \text{ mm}$  from the (filtered) power supply cable.

## Ground Connections

### Housing and Mounting Plate

By means of appropriate ground connections it is possible to avoid the emission of interference, because interference is discharged to earth on the shortest possible way. Ground connection of the metal housings of EMC-critical components such as filters, devices of the drive system, connection points of the cable shields, devices with microprocessor and switching power supply units have to be over a large surface area and well contacted. This also applies to all screw connections of between mounting plate and control cabinet wall and to the mounting of a ground bus to the mounting plate.

For this purpose it is recommended to use a zinc-coated or chromated mounting plate. Compared to a lacquered plate, the connections in this case have a good long-time stability.

### Connection Elements

For lacquered mounting plates always use screw connections with tooth lock washers and zinc-coated, tinned screws as connection elements. At the connection points selectively scratch off the lacquer so that there is safe electrical contact over a large surface area. Contact over a large surface area is established by means of bare connection surfaces or several connection screws. For screw connections the contact to lacquered surfaces is ensured by using tooth lock washers.

### Metal Surfaces

In any case use connection elements with good electroconductive surface.

Bare zinc-coated, tinned and chromated metal surfaces have **good electroconductive properties**. Anodized, yellow chromated, black gunmetal finish or lacquered metal surfaces have **bad electroconductive properties** and therefore shouldn't be used for connection elements (screws, nuts, plain washers).

### Ground Wires and Shield Connections

For connecting ground wires and shield connections it is not the cross section but the size of contact surface that is important, as the high-frequency interference currents mainly flow on the surface of the conductor.

Any connection of cable shields, especially of shields of the motor power cables with ground potential (see section "Connection of Motor Cable to Drive Controller") always has to be provided over a large surface area.

## Installing Signal Lines and Cables

### Line Routing

For measures to prevent interference see the Project Planning Manuals of the respective device. In addition, observe the following recommendations:

Signal and control lines have to be routed separately from the power cables with a minimum distance of  $d_5 = 100 \text{ mm}$  (see Fig. 6-31: ) or with a grounded separating sheet. The optimum way is to route them in separate cable ducts. If possible, lead signal lines into control cabinet at one point only.

Exception: If there is no other way to do it, motor feedback cables can be routed together with the motor power cables.

If signal lines are crossing power cables, they should be routed in an angle of  $90^\circ$  in order to avoid interference injection.

Spare cables that are not used and have been connected should be grounded at least at both ends so that they don't have any antenna effect.

Avoid unnecessary line lengths.

Run cables as close as possible to grounded metal surfaces (reference potential). The ideal solution are closed, grounded cable ducts or metal pipes which, however, is only obligatory for high requirements (sensitive instrument leads).

Avoid suspended lines or lines routed along synthetic carriers, because they are functioning both like good reception antennas (noise immunity) and like good transmitting antennas (emission of interference). Exceptional cases are trailing cable installations over short distance of a max. of 5 m.

### Shielding

The cable shield has to be connected immediately at the devices in the shortest and most direct possible way and over the largest possible surface area.

The shield of **analog signal lines** is connected at one end over a large surface area, normally in the control cabinet at the analog device. Make sure the connection to ground/housing is over a large surface area and short.

The shield of digital signal lines is connected at both ends over a large surface area and in short form. In the case of potential differences between beginning and end of the line, run an additional bonding conductor in parallel. The guide value for the cross section is  $10 \text{ mm}^2$ .

You absolutely have to equip separable connections with connectors with grounded metal housing.

In the case of non-shielded lines belonging to the same circuit, twist feeder and return cable.

## General Measures of Radio Interference Suppression for Relays, Contactors, Switches, Chokes, Inductive Loads

If, in conjunction with electronic devices and components, inductive loads, such as chokes, contactors, relays are switched by contacts or semiconductors, appropriate interference suppression has to be provided for them. In the case of d.c. operation, this is achieved by arranging free-wheeling diodes and in the case of a.c. operation, by arranging usual RC interference suppression elements depending on the contactor type, immediately at the inductance. Only the interference suppression element arranged immediately at the inductance serves this purpose. Otherwise the emitted noise level is too high which can affect the function of the electronic system and of the drive.

If possible, mechanical switches and contacts should only be realized as snap contacts. Contact pressure and contact material must be suited for the corresponding switching currents.

Slow-action contacts should be replaced by snap switches or by solid-state switches, because slow-action contacts strongly bounce and are in an undefined switching status for a long time which emits electromagnetic waves in the case of inductive loads. These waves are an especially critical aspect in the case of manometric or temperature switches.

## Installing the 24V Supply

As a matter of principle, the 24V supply of the components of the drive system Rexroth IndraDrive has to be installed in star-shaped form, i.e. for each group of drive controllers or third-party components it is necessary to run separate supply lines. This, too, applies to multiple-line arrangement in the case of supply from a supply unit, for example.

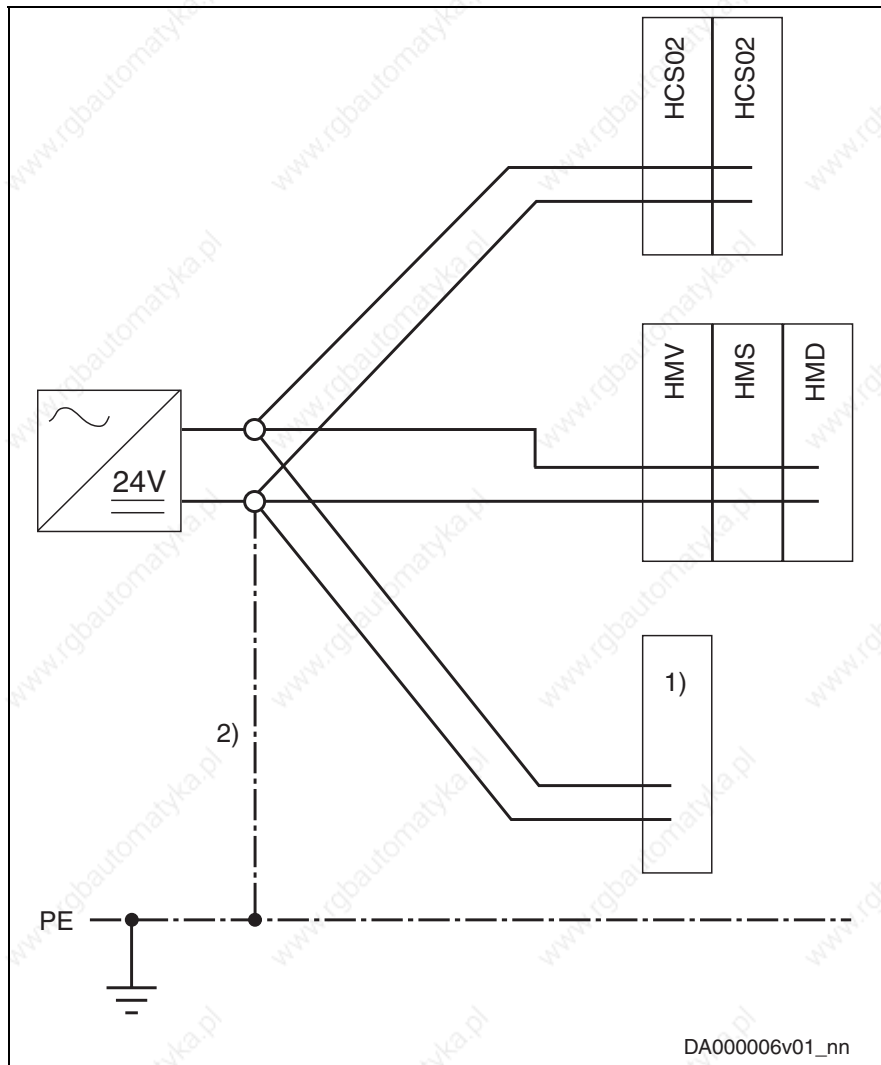

- 1) third-party component (e.g. PLC, valve etc.)
- 2) connection to central ground point (e.g. earth-circuit connector)

Fig. 6-34: Installing the 24V supply

**Note:** If you use several power supply units for 24 V supply, make sure that

- the reference conductors 0V of the individual power supply units are interconnected with low impedance
- the output voltages of the power supply units are within the allowed voltage range
- the power supply units are synchronously switched on and off.

# Connection Diagram

## HCS02

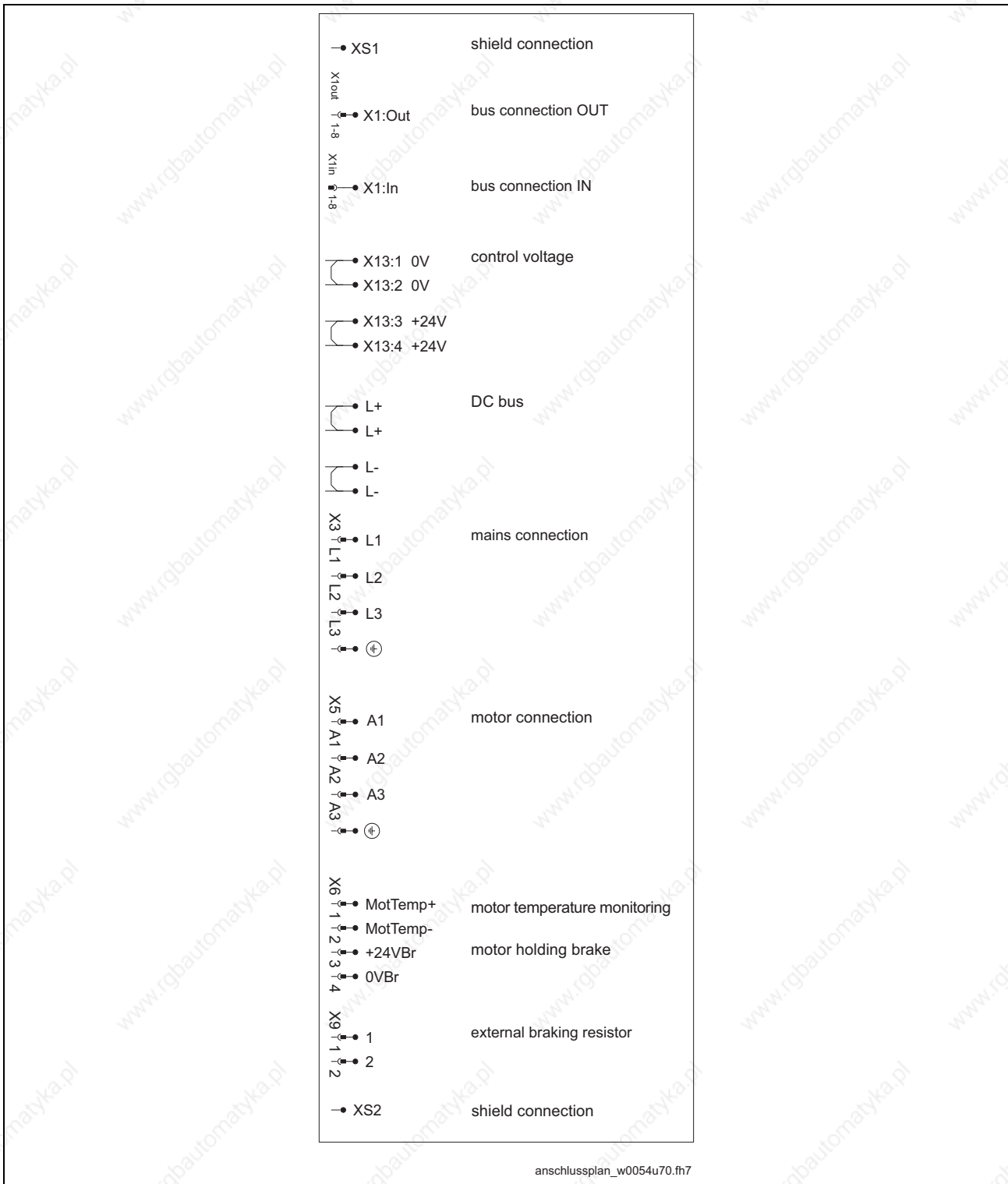

X1, L+/L- not available for HCS02.1E-W0012

X9 not available for HCS02.1E-W0012 and -W0028

Fig. 6-35: Complete connection diagram

**Note:** Apart from the connections listed below, it is necessary to wire the **Bb contact at the control section** for signaling the readiness for operation of the drive controller.



HCS03

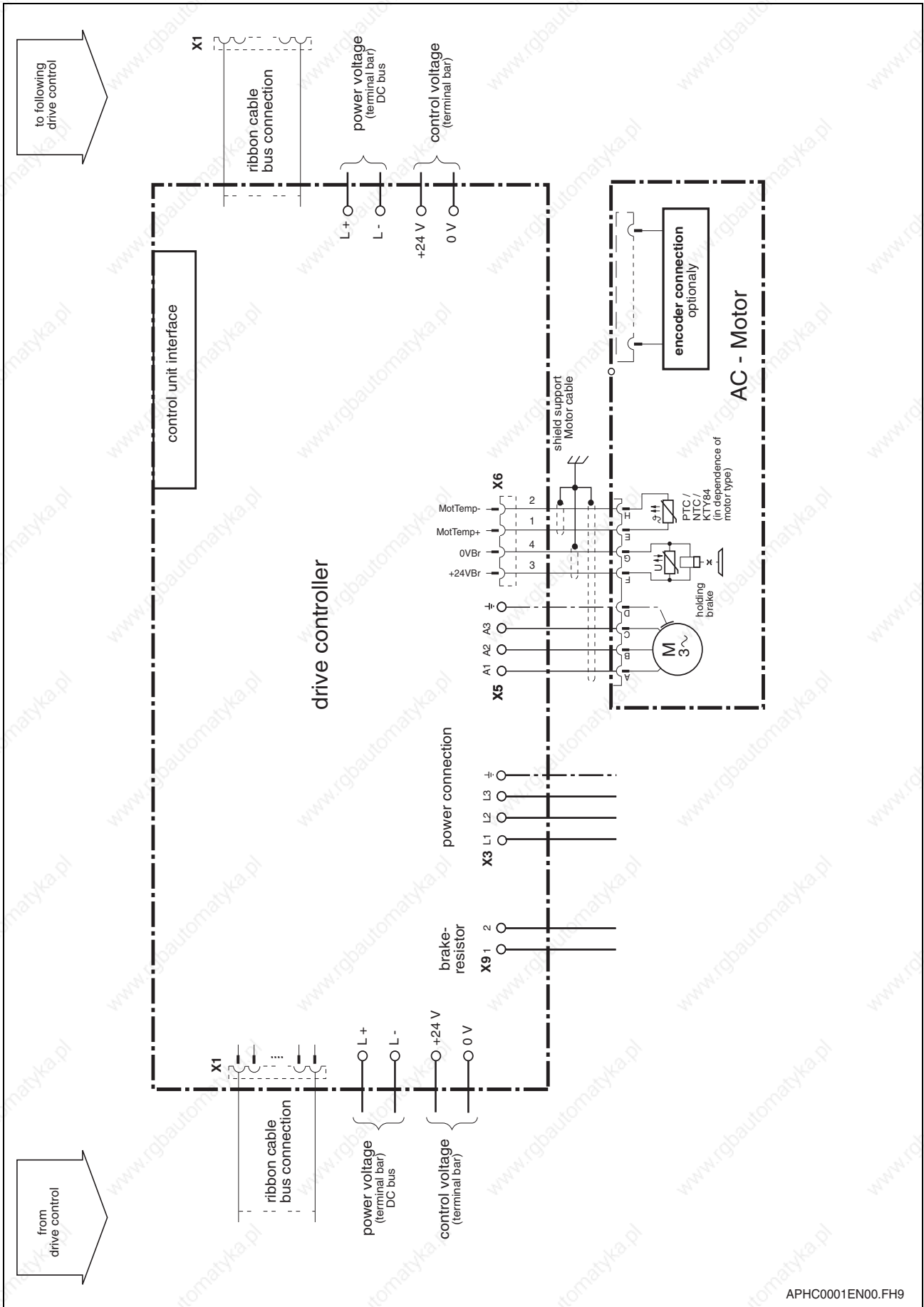

APHC0001EN00.FH9

Fig. 6-36: Connection diagram

## Connections and Connectors

## Power Sections HCS02.1E-W0012

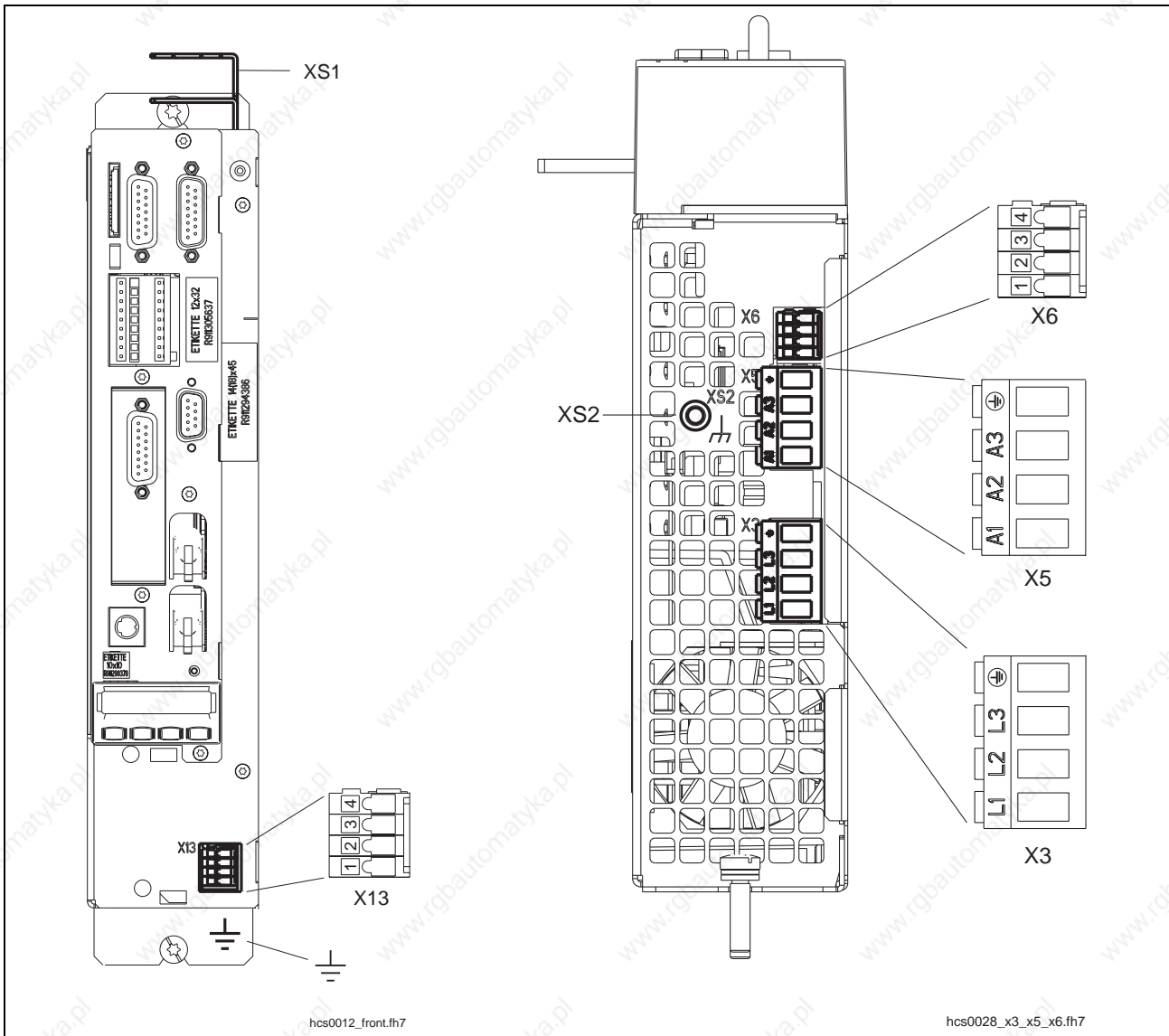

- X3: Mains connection
- X5: Motor connection
- X6: Motor temperature monitoring and motor holding brake
- X13: Control voltage connection
- XS1: Shield connection of signal cables
- XS2: Shield connection of motor cable

Fig. 6-37: HCS02.1E-W0012 power section connections (left: front, right: bottom)

Power Sections HCS02.1E-W0028, -W0054, -W0070

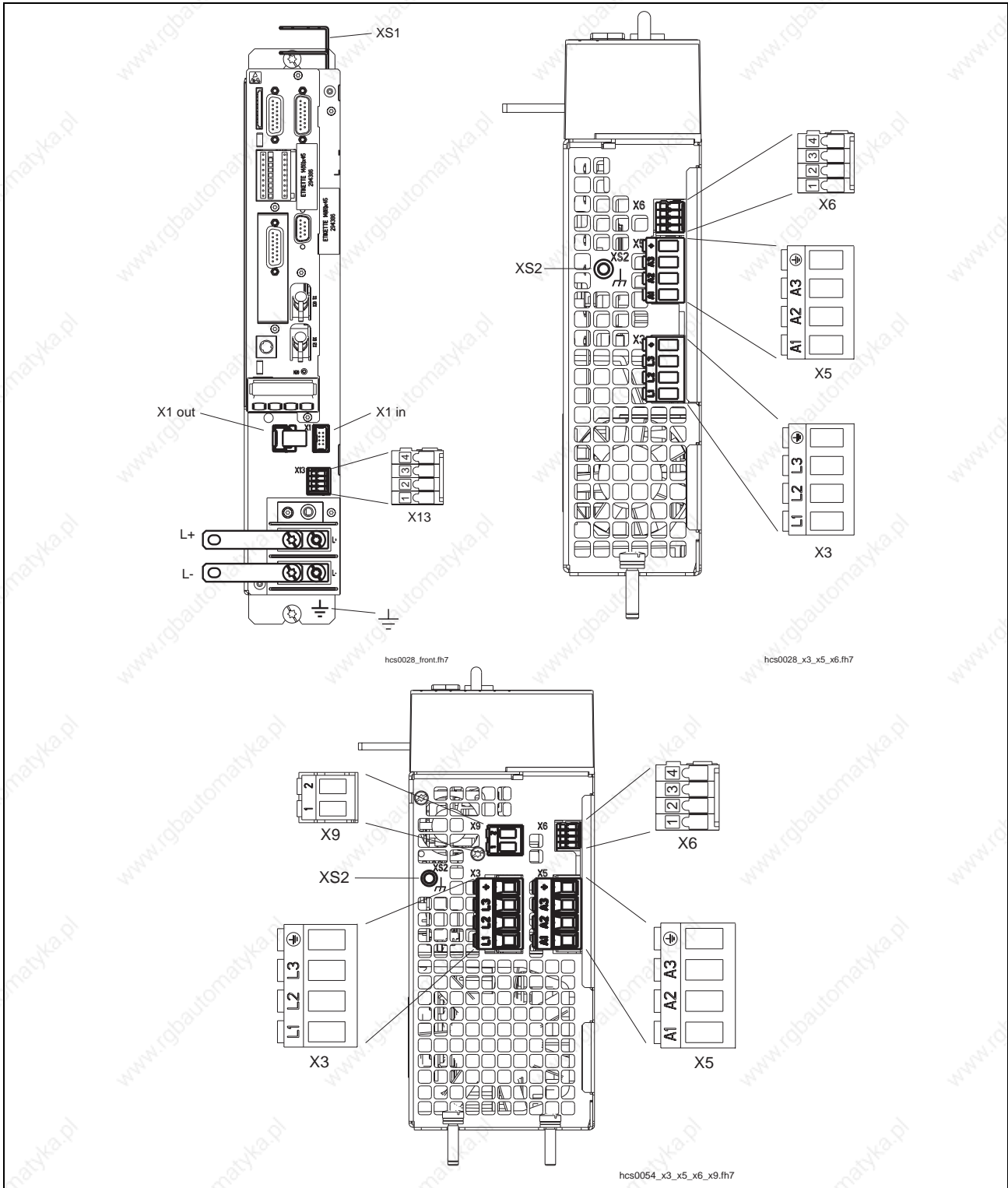

- X1: Module bus
- X3: Mains connection
- X5: Motor connection
- X6: Motor temperature monitoring and motor holding brake
- X9: Braking resistor connection
- X13: Control voltage connection
- XS1: Shield connection of signal cables
- XS2: Shield connection of motor cable

Fig. 6-38: HCS02.1E-W0028, -W0054, -W0070 power section connections (left above: front, right above: bottom –W0028, below: bottom –W0054 and –W0070)

Power Sections HCS03.1

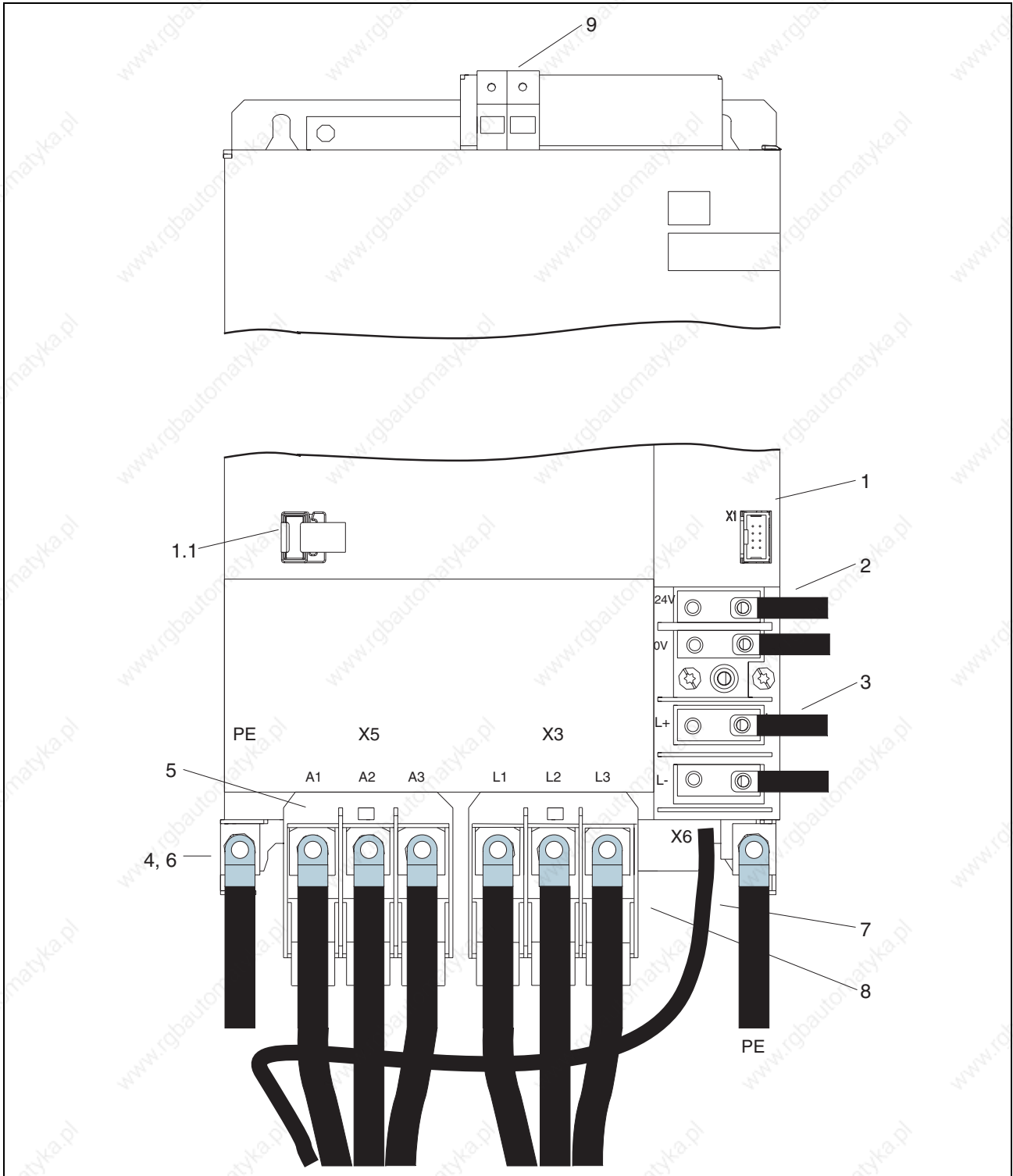

- 1, 1.1: Module bus X1
  - 2: Control voltage; +24 V and 0 V
  - 3: DC bus; L+ and L-
  - 4: Connection of equipment grounding conductor
  - 5: Motor
  - 6: Shield connection of motor cable
  - 7: Motor temperature monitoring and motor holding brake (X6)
  - 8: Mains connection
- Fig. 6-39: Connections at power section HCS03.1

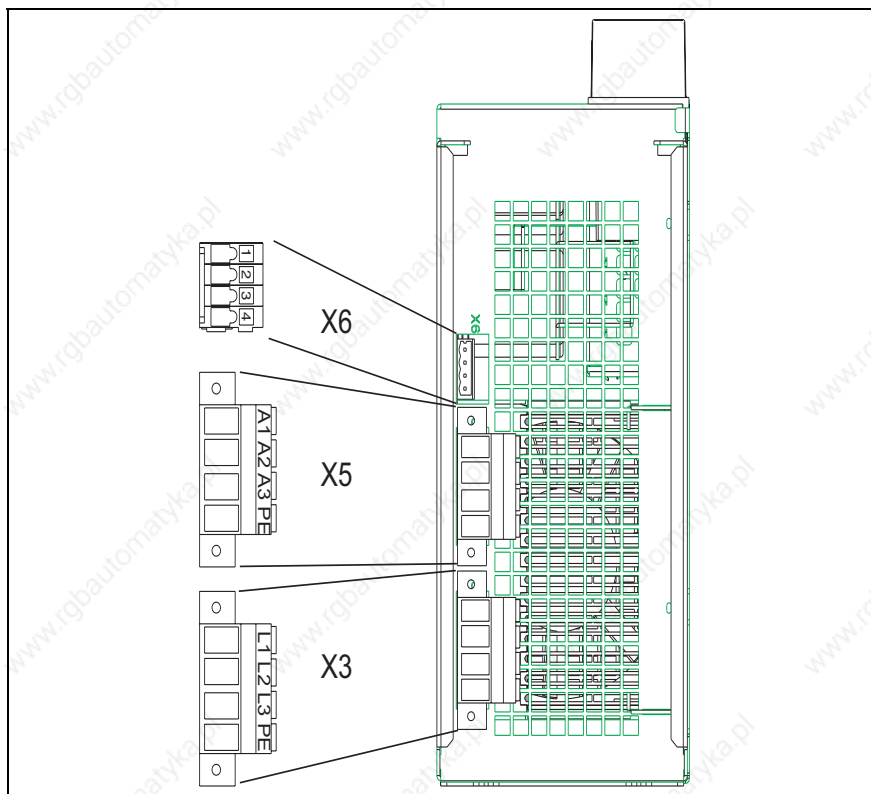

- X3: Mains connection
- X5: Motor connection
- X6: Connection of motor temperature, motor holding brake

Fig. 6-40: Connections at power section (bottom) HCS03.1E-W0070

### X1, Module Bus

The module bus permits data exchange between the drive controllers.

#### Graphic Representation

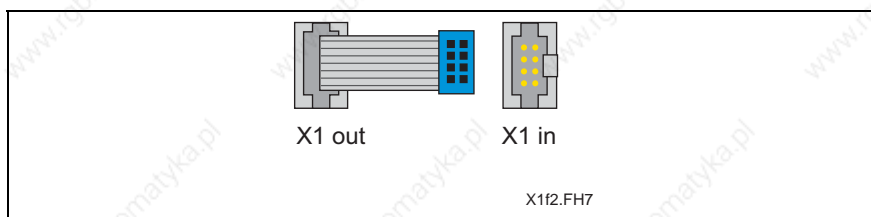

Fig. 6-41: X1

#### Design

Type	No. of poles	Type of design
Ribbon cable connector	8	Connector at device
Ribbon cable socket	8	Socket at ribbon cable

Fig. 6-42: Design

### X3, Mains Connection



**DANGER**

**High electrical voltage! Danger to life, severe bodily harm by electric shock!**

⇒ Always operate the drive controller with plugged on connector!

Design

HCS02.1E-	Type	Number of poles	Type of design
W0012	Screw terminal block	4	Pins on device
W0028	Screw terminal block	4	Pins on device
W0054	Screw terminal block	4	Pins on device
W0070	Screw terminal block	4	Pins on device

Fig. 6-43: Design

HCS03.1E-	Type	No. of poles	Type of design
W0070	Connector	4	Screw connection
W0100	Terminal block	3	Screw connection for M6 ring cable lugs
W0150	Terminal block	3	Screw connection for M6 ring cable lugs
W0210	Terminal block	3	Screw connection for M10 ring cable lug

Fig. 6-44: Design

Identification of the individual connections:

Identification	Significance
L1	phase 1
L2	phase 2
L3	phase 3
 (PE)	equipment grounding conductor

Fig. 6-45: Identification of the individual connections mains connection

**Note:** Only with single-phase operation: connect the connecting lines of the mains voltage supply L1 and N with the connections L1 and L2.

Connection Cross Section

HCS02.1E-	Cross section single-wire [mm <sup>2</sup> ]	Cross section multi-wire [mm <sup>2</sup> ]	Cross section in AWG
W0012, W0028	0,2-4	0,2-4	24-10
W0054, W0070	0,5-10	0,5-10	20-8

Fig. 6-46: Connection cross section

HCS03.1E-	Cross section single-wire [mm <sup>2</sup> ]	Cross section multi-wire [mm <sup>2</sup> ]	Cross section in AWG
W0070	16	-	6
W0100	35	-	2
W0150	50	2*25	0
W0210	95	2*50	4/0

Fig. 6-47: Connection cross section

**Tightening Torque**

HCS02.1E-	Tightening torque [Nm]
W0012, W0028	0,5 – 0,6
W0054, W0070	1,2 – 1,5

Fig. 6-48: Tightening torques

HCS03.1E-	Tightening torque [Nm]
W0070	1,5
W0100, W0150	6
W0210	25

Fig. 6-49: Tightening torques

**CAUTION****Damage to the drive controller**

⇒ Strain relief for the motor power cable must be provided within the control cabinet, or you can use the optionally available connection accessory HAS02.1.

**Note:** Observe the following for use within the scope of C-UL:

- Use 60/75 °C copper wire only
- Use Class 1 wire only or equivalent
- Suitable for use on a circuit capable of delivering not more than 8 kA (10 kA) rms symmetrical amperes for a maximum voltage of 500 V (400 V)

**X5, Motor Connection****DANGER****High electrical voltage! Danger to life, severe bodily harm by electric shock!**

⇒ Always operate the drive controller with plugged on connector!

**Design**

HCS02.1E-	Type	No. of poles	Type of design
W0012..0070	Screw terminal block	4	Pins on device

Fig. 6-50: Design

HCS03.1E-	Type	No. of poles	Type of design
W0070	Connector	4	Screw connection
W0100, W00150	Terminal block	3	Screw connection for M6 ring cable lugs
W0210	Terminal block	3	Screw connection for M10 ring cable lugs

Fig. 6-51: Design

Identification of the individual connections:

Identification	Significance
A1	phase 1
A2	phase 2
A3	phase 3
 (PE)	equipment grounding conductor

Fig. 6-52: Identification of the individual connections motor connection

#### Short Circuit Protection

The outputs A1, A2, A3 are short-circuit proof at the device output against each other and against ground.

#### Connection Cross Section

HCS02.1E-	Cross section single-wire [mm <sup>2</sup> ]	Cross section multi-wire [mm <sup>2</sup> ]	Cross section in AWG
W0012, W0028	0,2-4	0,2-4	24-10
W0054, W0070	0,5-10	0,5-10	20-8

Fig. 6-53: Connection cross section

HCS03.1E-	Cross section single-wire [mm <sup>2</sup> ]	Cross section multi-wire [mm <sup>2</sup> ]	Cross section in AWG
W0070	16	-	6
W0100	35	-	2
W0150	50	2*25	0
W0210	95	2*50	4/0

Fig. 6-54: Connection cross section

#### Tightening Torque

HCS02.1E-	Tightening torque [Nm]
W0012, W0028	0,5 – 0,6
W0054, W0070	1,2 – 1,5

Fig. 6-55: Tightening Torque

HCS03.1E-	Tightening torque [Nm]
W0070	1,5
W0100, W0150	6
W0210	25

Fig. 6-56: Tightening Torque



### Connection of the Motor Power Cable

For the connection between drive controller and motor, use Rexroth motor power cables (see documentation "Rexroth Connection Cables; Selection Data", DOK-CONNEC-CABLE\*STAND-AUxx-EN-P).



**CAUTION**

### Damage to the drive controller!

⇒ Strain relief for the motor power cables cannot be provided at the drive controller. Therefore, make sure strain relief of the motor power cables is provided in the control cabinet or cable use our special accessories **HAS02.1**.

### Connection of Motor Cable to Drive Controller

There are the following minimum requirements for connecting the motor cables to the drive controller:

- Connect the shield of the motor cable **over the largest possible surface area (with low impedance)** to the drive controller. The connection of cable shields by means of round wires (so-called "pig tails") at the cable ends to ground and housing is normally insufficient.
- Make sure there is sufficient **strain relief** for the motor cable itself.

### Shield Connection with Accessory HAS02

Optional accessory HAS02 to be used with connection over a large surface area directly to the device. This is the best solution. The figure below illustrates this by the example of HCS02 drive controllers:

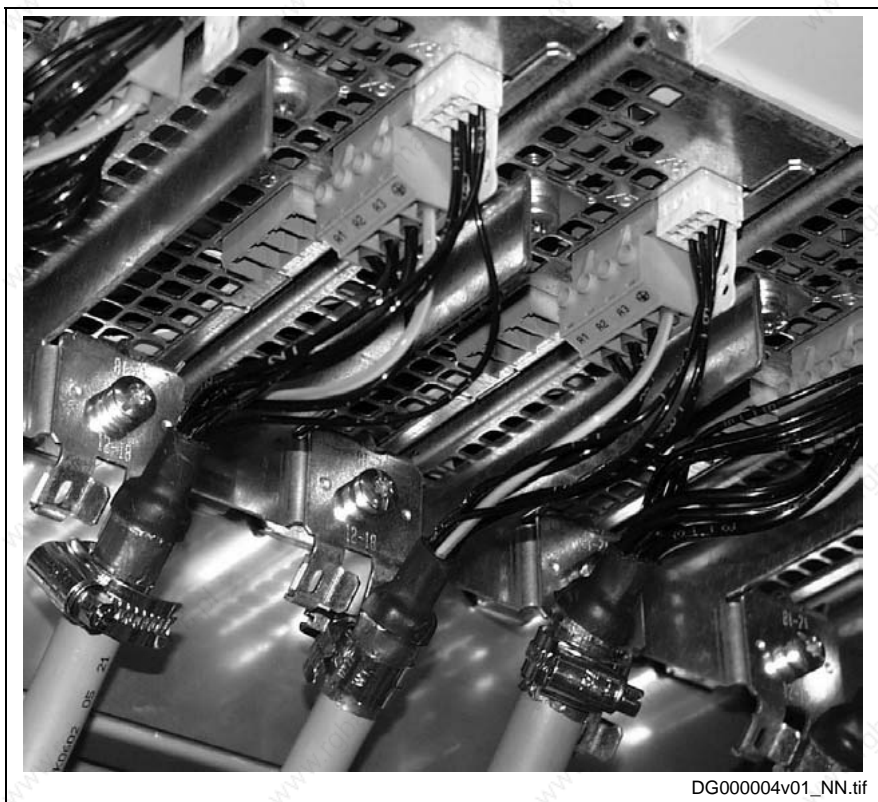

DG000004v01\_NN.tif

Fig. 6-57: Connecting HAS02 to HCS02

### Shield Connection without Accessory HAS02

For shield connection without HAS02 accessory connect the cable shield with the lowest possible impedance to the drive controller.

The following paragraphs describe two basic alternatives of this kind of connection.

**Alternative 1** Connect cable shield to a ground bus. The maximum distance between ground bus and device connection is 100 mm. For this purpose take the given length of the single strands at the cable end into account for ready-made Rexroth motor power cables.

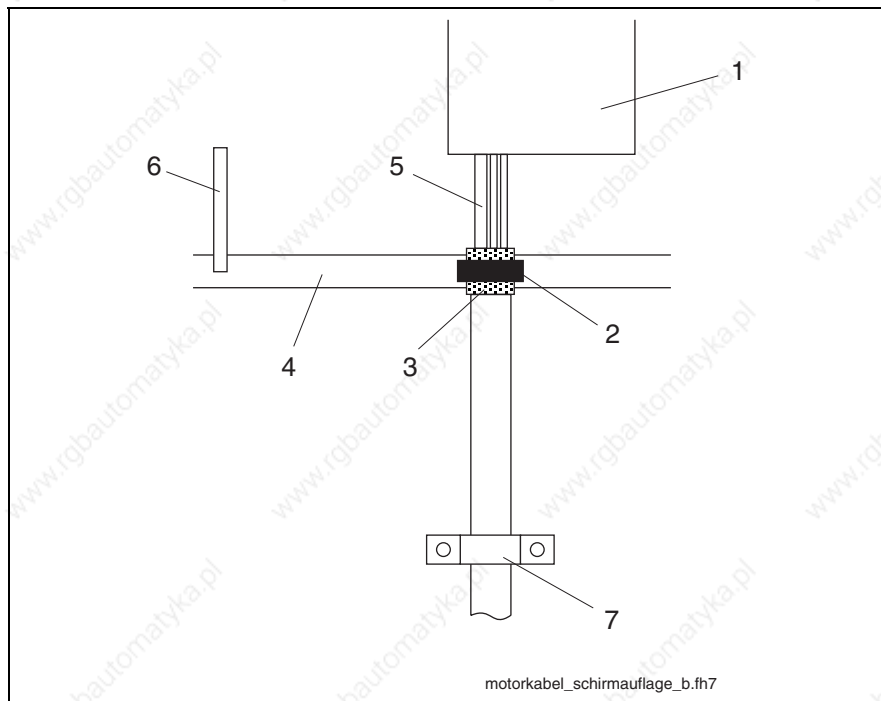

- 1: drive controller
- 2: clip for shield contact
- 3: overall shield of the motor power cable folded back
- 4: ground bus in control cabinet
- 5: single strands of motor power cable
- 6: connection of ground bus to supplying device
- 7: strain relief (as near as possible to control cabinet outlet)

Fig. 6-58: Shield contact, alternative 1

- With a clip (2) connect overall shield of motor power cable (3) to ground bus (4).  
(If you use your own cable make sure the shields of the two inner pairs of wires are in contact with the overall shield.)
- With a cable (6) (line cross section at least 10 mm<sup>2</sup>) connect ground bus (4) to ground connection at supplying device (Rexroth IndraDrive supply unit or Rexroth IndraDrive drive controller HCS).

**Alternative 2** Connect cable shield to a ground bus. The cable length between device and ground bus mustn't be more than a max. of 1 m. For this purpose prepare the motor cable in accordance with the description below:

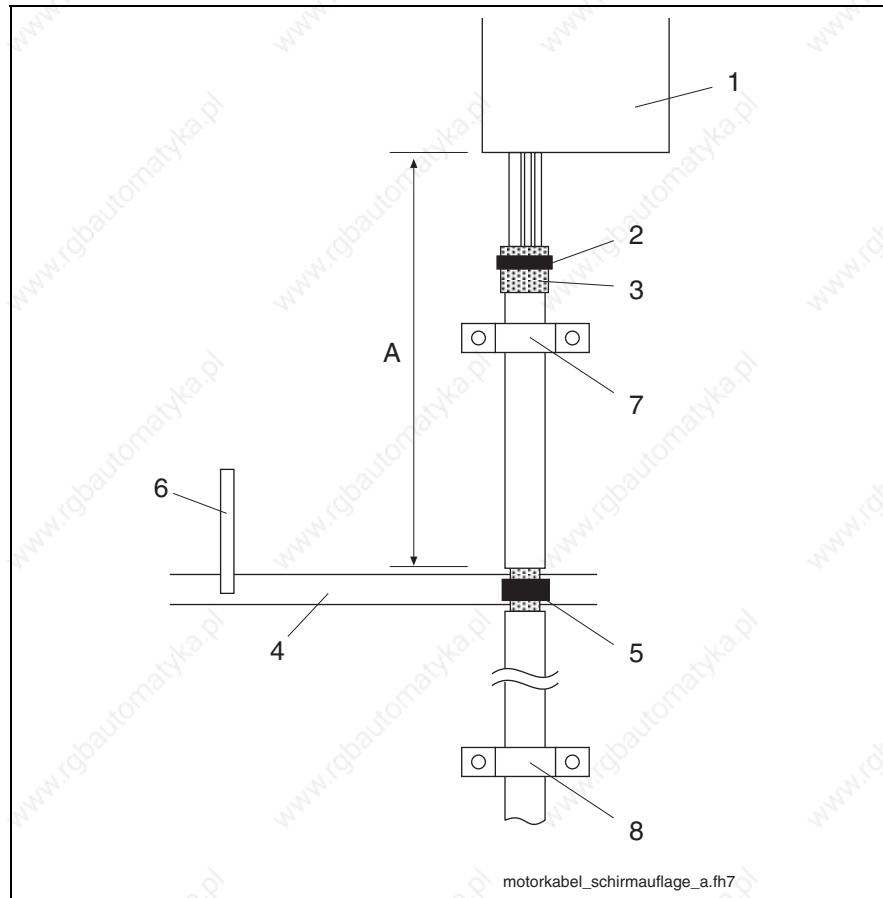

- 1: drive controller
- 2: cable tie
- 3: overall shield of the motor power cable folded back
- 4: ground bus in control cabinet
- 5: connection between overall shield of motor power cable laying bare and ground bus
- 6: connection of ground bus to supplying device
- 7: strain relief (as near as possible to the drive-side cable end)
- 8: strain relief (as near as possible to control cabinet outlet)
- A: cable length between ground bus and device: < 1m

Fig. 6-59: Shield contact, alternative 2

- With a cable tie (2) press the drive-side cable end in such a way that the shields of the two inner pairs of wires (motor temperature, holding brake) have good contact with the overall shield of the motor power cable (3).  
(If you use your own cable make sure the shields of the two inner pairs of wires are in contact with the overall shield.)
- On the level of the ground bus in the control cabinet remove a piece of the cable sheath from the motor power cable in order to lay bare the overall shield (5).
- Connect overall shield (5) to ground bus in the control cabinet with an appropriate connection (clip). The connection must have a cross section of at least 10 mm<sup>2</sup>.
- With a cable (6) (line cross section at least 10 mm<sup>2</sup>) connect ground bus (4) to ground connection at supplying device (Rexroth IndraDrive supply unit or Rexroth IndraDrive drive controller HCS).
- Make sure there is sufficient strain relief for the motor power cable as near as possible to the drive-side cable end (7).

- In addition, make sure there is sufficient strain relief for the motor power cable as near as possible to the control cabinet outlet of the motor power cable (8).

**Note:** Do not remove the shield of the motor cable between ground bus and device.

If the motor cables are routed to the control cabinet via flange boxes, the shield is directly connected to the wall of the control cabinet over a large surface area via the housing of the flange box. Make sure there is sufficient separate strain relief.

**Bonding Conductor**

Bad ground connection between motor housing and control cabinet housing, as well as long motor cables, can require additional routing of a bonding conductor of a cross section of normally 10 mm<sup>2</sup> between control cabinet housing and motor housing.

**Note:** For cable lengths of more than 50 m the cross section should be at least 35 mm<sup>2</sup>.

**Shield Connection of Kit Motors**

For kit motors make sure that the connection lines are run in shielded form or under metal between winding and terminal box, if the terminal box is not directly mounted on the spindle case.

**Shield Connection for Linear Motors**

For linear motors connect the shield of the connection cable between primary part and terminal box via clips to machine housing or metal shell.

**Shielding of Temperature Monitor and Brake**

The inner shields of temperature monitor and brake in the motor cable are connected to the drive controller at one end.

**X6, Motor Temperature Monitoring and Motor Holding Brake**

The drive controller is supplied with 24V for the motor holding brake via the control voltage connection.



**High electrical voltage! Danger to life, severe bodily harm by electric shock!**

⇒ Always operate the drive controller with plugged on connector, because high voltages can occur at the connector at the end of the cable (coming from motor)!

**Design**

Type	Number of poles	Type of design
Spring tension	4	Pins on device

Fig. 6-60: Design

**Connection**

1	MotTemp+	Monitoring the motor temperature
2	MotTemp-	
3	+24 V	Motor holding brake
4	0 V	

**Connection Cross Section HCS02.1N-W0012, -W0028, -W0054, -W0070:**

Cross section single-wire [mm <sup>2</sup> ]	Cross section multi-wire [mm <sup>2</sup> ]	Cross section in AWG
0.14-1.5	0.14-1.5	28-16

Fig. 6-61: Connection cross section

**HCS03.1E-W0070:**

Cross section single-wire [mm <sup>2</sup> ]	Cross section multi-wire [mm <sup>2</sup> ]	Cross section in AWG
1,5	1,5	16

Fig. 6-62: Connection cross section X6 (HCS03.1E-W0070)

**HCS03.1E-W0100, -W0150 and W0210:**

Cross section single-wire [mm <sup>2</sup> ]	Cross section multi-wire [mm <sup>2</sup> ]	Cross section in AWG
2,5	2,5	12

Fig. 6-63: Connection cross section X6 (HCS03.1E-W0100...0210)

**Note:** Make sure the voltage supply for the motor holding brake is sufficient. In this respect observe the lengths and cross sections of the cables used.

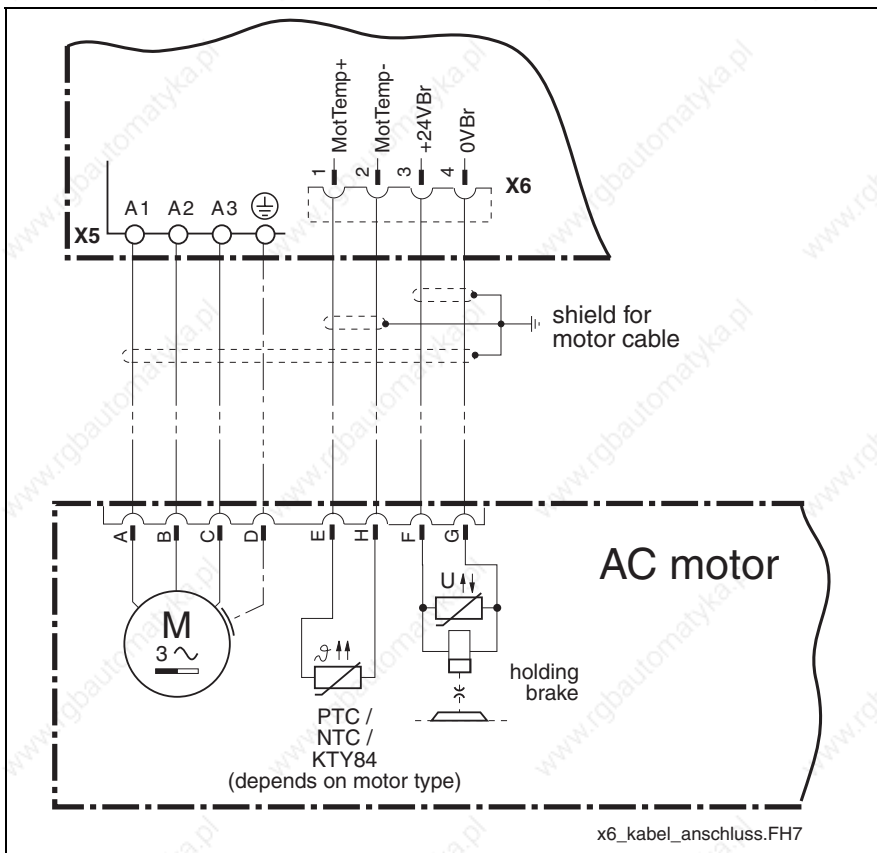

Fig. 6-64: Motor cable, temperature monitor and holding brake connection

**CAUTION****Maximum allowed braking current:**

- HCS02.1N-W0012...-W0070: 2.0 A<sub>eff</sub>
- HCS03.1N-W0070...-W0210: 2.0 A<sub>eff</sub>

Where braking currents are higher, the motor holding brake must be activated by means of an external contact element.

The contact elements used in the drive controller are subject to wear. **Guaranteed number of switching actions** at max. time constant of load < 50 ms ( $L_{\text{Brake}}/(24V/I_{\text{Brake}})$ ): **250.000**.

**Maximum switching frequency: 0.5 Hz**

**DANGER****Dangerous movements! Danger to personnel from falling or slipping axes!**

- ⇒ The standard motor holding brake provided or an external motor holding brake controlled directly by the drive controller are not sufficient on their own to guarantee the safety of personnel!
- ⇒ Personnel safety must be achieved using higher-ranking, fail-safe procedures:  
Dangerous areas should be blocked off with protective fences or grids.  
Additionally secure vertical axes against falling or sinking after switching off the motor power by, for example:
  - mechanically locking the vertical axis
  - providing external braking/catching/clamping mechanisms
  - adequately counterbalancing the axis.

For the current consumption of the motor holding brake see the project planning documentation for the AC motors.

The motor holding brake of the AC motors has not been designed as a service brake. After approximately 20,000 motor revolutions against the closed brake armature disc it will be worn.

The drive controller can assume the control of the motor holding brake.

**Controlling the Motor Holding Brake****X9, Connection of Braking Resistor****DANGER****Lethal electric shock caused by live parts with more than 50 V!**

- ⇒ Exclusively operate the drive controller with plugged on connector!

Design

HCS02.1E-	Type	No. of poles	Type of design
W0054, W0070	Screw terminal block	2	Pins on device

Fig. 6-65: Design

HCS03.1E-	Type	No. of poles	Type of design
W0070	Connector	2	Screw connection
W0100..0210	Screw terminal block	2	Screw connection

Fig. 6-66: Design

Identification of the individual connections::

Identification	Significance
1	Phase 1
2	Phase 2

Fig. 6-67: Identification of the individual connections

**Connection Cross Section**

HCS02.1E-	Cross section single-wire [mm <sup>2</sup> ]	Cross section multi-wire [mm <sup>2</sup> ]	Cross section in AWG
W0054, W0070	0,5-10	0,5-10	20-8

Fig. 6-68: Connection cross sections

HCS03.1E-	Cross section in [mm <sup>2</sup> ]	Cross section in AWG
W0070	16	6
W0100, W0150	25	4
W0210	50	0

Fig. 6-69: Connection cross sections

**Tightening Torque**

HCS02.1E-	Tightening torque [Nm]
W0054, W0070	1,2 – 1,5

Fig. 6-70: Tightening torque

HCS03.1E-	Tightening torque [Nm]
W0070	1,5
W0100, W0150	2
W0210	8

Fig. 6-71: Tightening torque



**CAUTION**

**Damage to the drive controller!**

⇒ You have to provide strain relief for the connection cable in the control cabinet or use the optionally available connection accessory (shielding plate; HAS02.1).

**Note:** With twisted or shielded cable, the maximum cable length for the braking resistor is 5 m.

### X13, Control Voltage (+24 V, 0 V)

The external 24V supply is applied via connection X13 for

- the power section of the drive controller
- brake control via X6 and
- the control section of the drive controller

With regard to control voltage supply, the HCS02.1 drive controllers are available in two different designs.

- Standard design HCS02.1E-W\*\*\*\*-\*\*\*N:

The control voltage is supplied by an external 24V power supply unit.

- Optional design HCS02.1E-W\*\*\*\*-\*\*\*V:

The control voltage is supplied by an integrated 24V power supply unit.

A power supply unit that makes available the control voltage supply for the power section and the control section from the DC bus is integrated in the drive controller.

- 
- Note:**
- Falling short of the permissible control voltage leads to a corresponding error message (=> refer also to firmware function description).
  - Interruption to the control voltage when the motor is running leads to torque-free (brakeless) runout in the motor.
- 

**Note on design -\*\*\*V:**

- The brake supply has to be realized via an external power supply unit.
  - Applying the external supply voltage for the purpose of buffering at no-power operation is allowed.
  - Load at the terminal X13 is not allowed.
- 



**DANGER**

**Dangerous movement caused by brakeless motor coasting to stop in the event of an interruption to the control voltage supply!**

- ⇒ Do not stay within the motional range of the machine. Possible measures to prevent personnel from accidentally accessing the machine:
    - protective fencing
    - protective grid
    - protective cover
    - light barrier.
  - ⇒ Fencing and covers must be adequately secured against the maximum possible force of movement.
-



Design	Type	Number of poles	Type of design
	Spring power	4	Pins on connector

Fig. 6-72: Design

Connection Cross Section	Cross section single-wire [mm <sup>2</sup> ]	Cross section multi-wire [mm <sup>2</sup> ]	Cross section in AWG
	0.14-1.5	0.14-1.5	28-16

Fig. 6-73: Connection Cross Section

Connection		
	3, 4	+24 V
	1, 2	0 V

Fig. 6-74: Identification of the individual connections

Load Capacity		
	looping through the power supply	up to max. 6 A <sub>eff</sub> allowed
	polarity reversal protection	over the allowed voltage range by internal protective diode of +24V circuit

Fig. 6-75: Load capacity

**Note:** The input 0 V connected in conductive form with the housing potential. It is therefore impossible to use an insulation monitor at +24 V and 0 V against housing.

Lines +24 V and 0 V		
	line cross section	min. 1 mm <sup>2</sup>
	line routing	preferably in parallel
	max. allowed inductance between 24V supply source and X13	100 µH (corresponds to approx. 2*75 m)

Fig. 6-76: Supply line 24 V

The control voltage supply is routed to the connection X13 from above (see following figure).

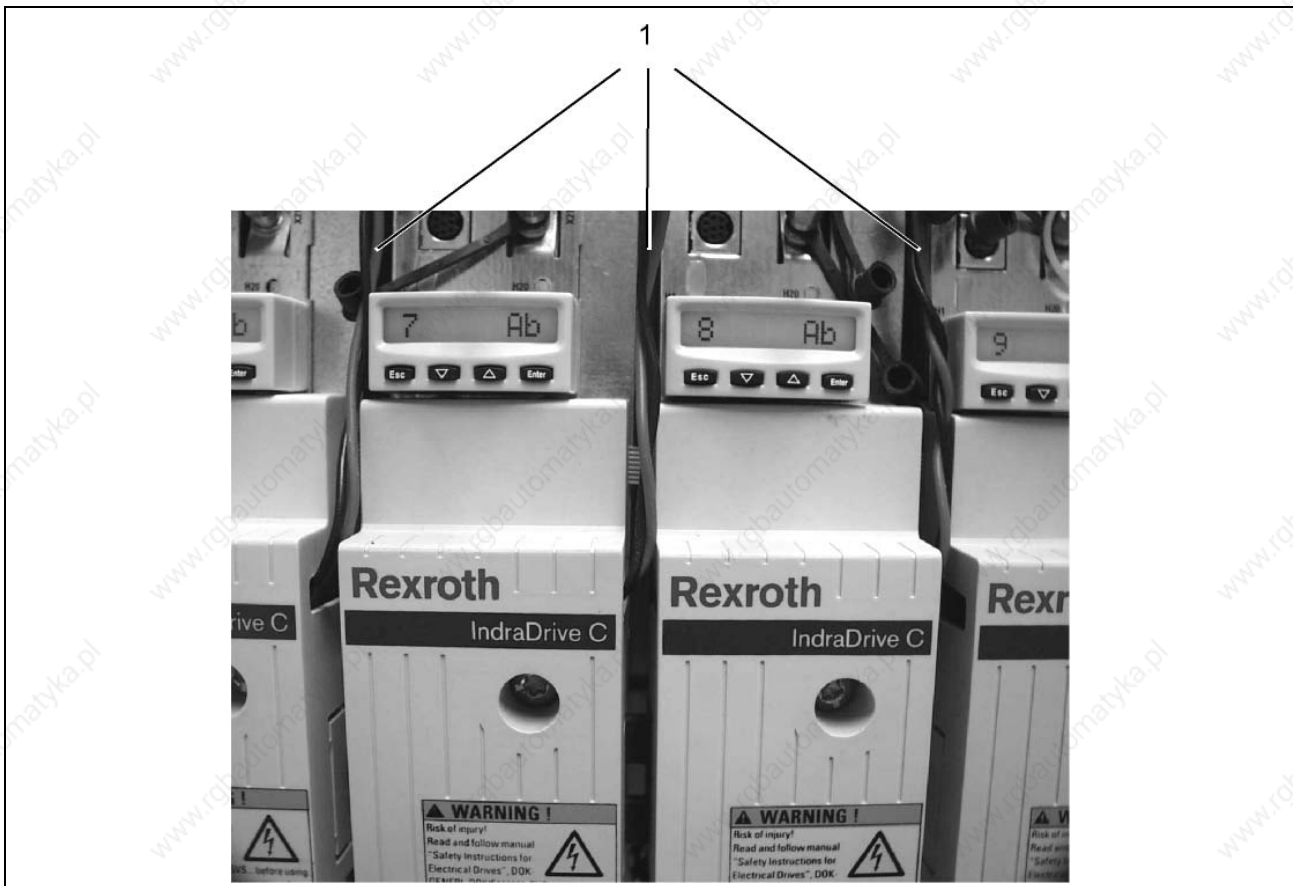

1: lines to control voltage supply

Fig. 6-77: Control voltage supply at X13

### Optional Control Voltage (HCS03)

Control voltage is supplied by an external 24V power supply unit.

**Note:** Technical data of control voltage: see section "Electrical Data"

#### Design

The control voltage supply is connected via contact bars and screws (M6) at the front of the drive controller. Depending on the width of the drive controllers, there are contact bars of different lengths.

#### Tightening Torque

6 Nm

#### Multiple-Line Arrangement

The following figures show the correct control voltage connection for stacked drive controllers. The illustrated way of connection ensures that the touch guard can be correctly mounted and the required clearances and creepage distances can be complied with.

The cables have to be twisted. Observe the notes in chapter "Arranging the Components in the Control Cabinet", section "Installing the 24V Supply".

Cable Routing to the Left:

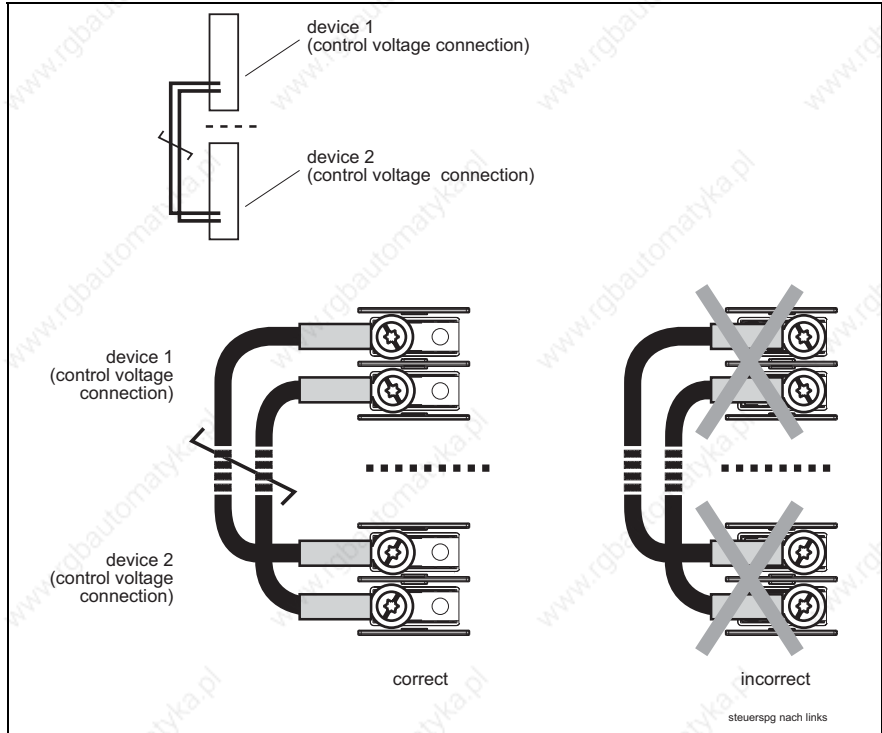

Fig. 6-78: Control voltage connections for cable routing to the left

Cable Routing to the Right:

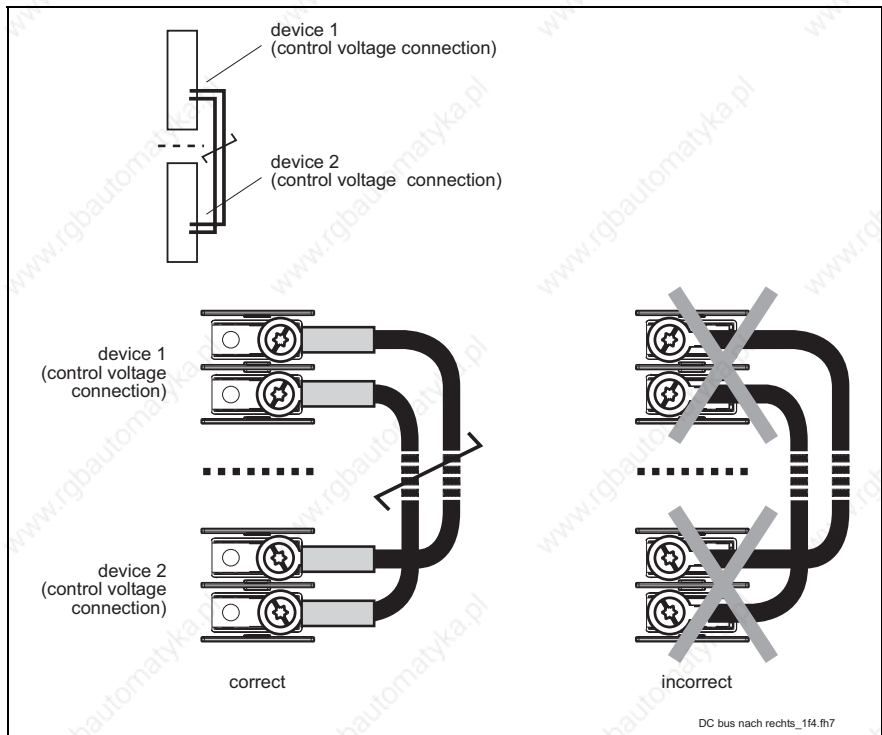

Fig. 6-79: Control voltage connections for cable routing to the right

## DC Bus (L+, L-)

By means of the DC bus connection, the following components are linked:

- several drive controllers to one another, and
- drive controllers to additional components in order to
  - increase the stored power by means of DC bus capacitor unit
  - increase the permissible braking resistor continuous output by means of DC bus resistor unit

### Design

The DC bus is connected via contact bars and screws (M6) at the front of the drive controller. Depending on the width of the drive controllers, there are contact bars of different lengths.

### Tightening Torque

6 Nm

### DC Bus Wiring

If in special cases it is not possible to use the DC bus rails for connection, connection must be established using the shortest possible twisted wires.

Length of twisted wire	HCS02: max. 2 m HCS03: max. 4 m
Wire cross section	min. 10 mm <sup>2</sup> , but not less than supply feeder cross section
Wire protection	by means of fuses in the mains supply
Dielectric strength of single strand against ground	≥ 750 V (e.g.: strand type - H07)



**CAUTION**

### Damage caused by voltage arcing!

⇒ If drive controllers are stacked in the control cabinet, the connections for the DC buses between the drive controllers have to be correctly made.

The figures below illustrate the correct DC bus connection for stacked drive controllers. The illustrated way of connection keeps bare wire sections from being situated directly vis-à-vis. This avoids voltage arcing.

The cables have to be twisted.



**CAUTION**

### Risk of damage!

⇒ Connect the devices both to the left and to the right screw connection at the terminal block.

Cable Routing to the Left:



**CAUTION**

**Damage caused by voltage arcing!**

⇒ Insulate ring terminals and connecting lines with a heat-shrinkable sleeve. Afterwards only strip the insulation of the contact surface of the ring terminal. Realize connections according to figure.

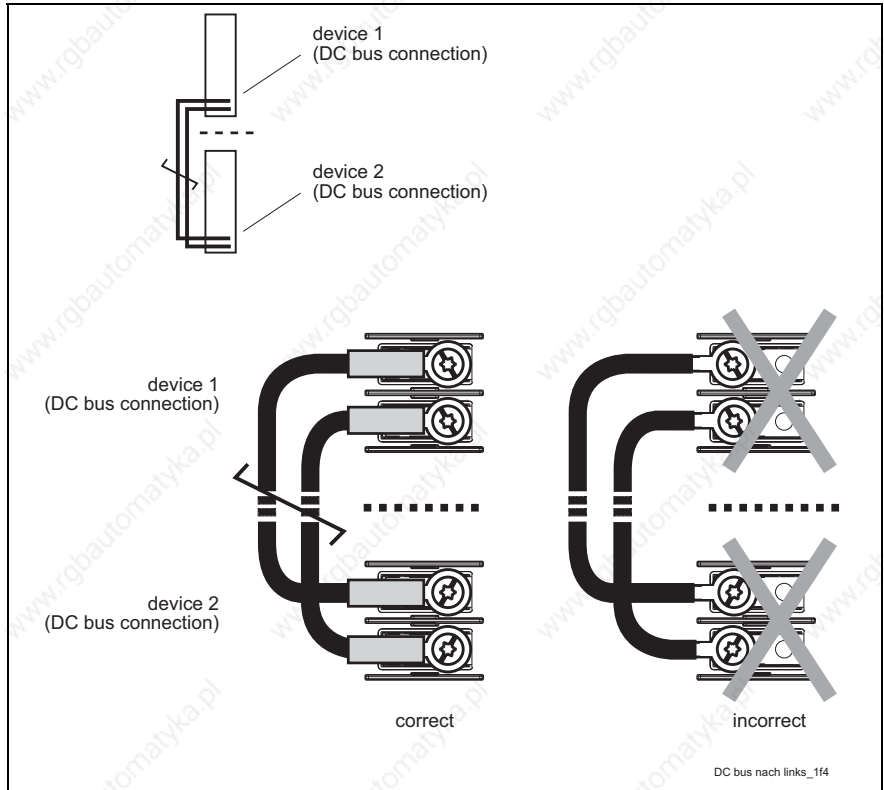

Fig. 6-80: DC bus connections for cable routing to the left

Cable Routing to the Right:



**CAUTION**

### Damage caused by voltage arcing!

⇒ Insulate ring terminals and connecting lines with a heat-shrinkable sleeve. Afterwards only strip the insulation of the contact surface of the ring terminal.

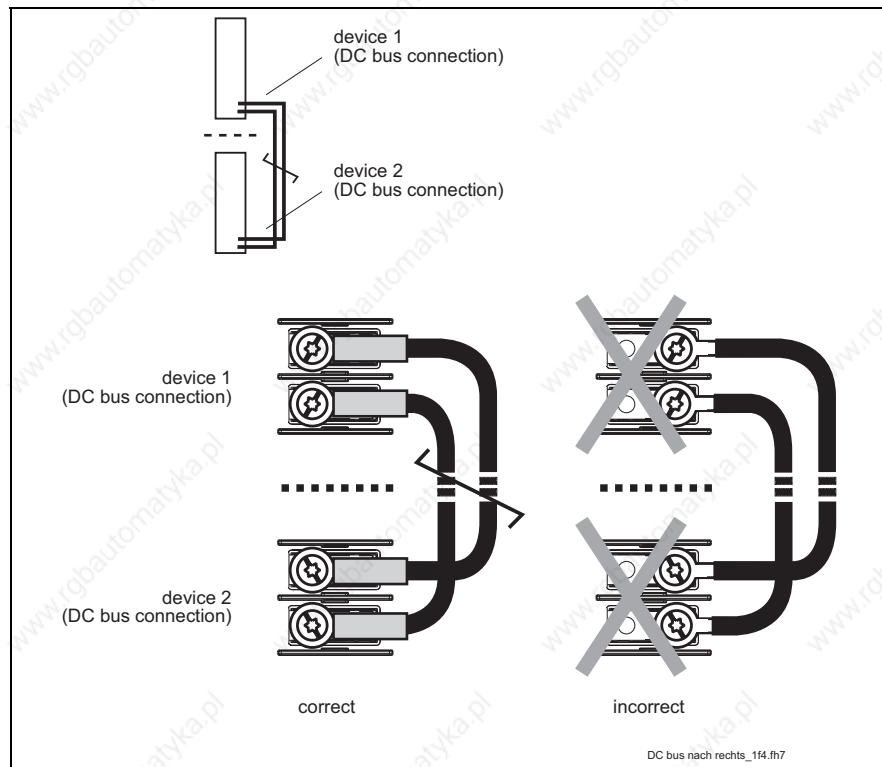

Fig. 6-81: DC bus connections for cable routing to the right

## Connection Point of Equipment Grounding Conductor and Equipment Grounding Connections



**DANGER**

### Dangerous contact voltage at device housing! Lethal electric shock!

⇒ Connect the drive controller to the equipment grounding system via connection X3 (mains).

## Ground Connection of Housing

The ground connection of the housing is used to provide functional safety of the drive controllers and protection against contact in conjunction with the equipment grounding conductor.

Ground the housings of the drive controllers:

1. Connect the bare metal back panel of the drive controller in conductive form to the mounting surface in the control cabinet. To do this use the supplied mounting screws.
2. Connect the mounting surface of the control cabinet in conductive form to the equipment grounding system.

### XS1, Shield Connection (Control Wires)

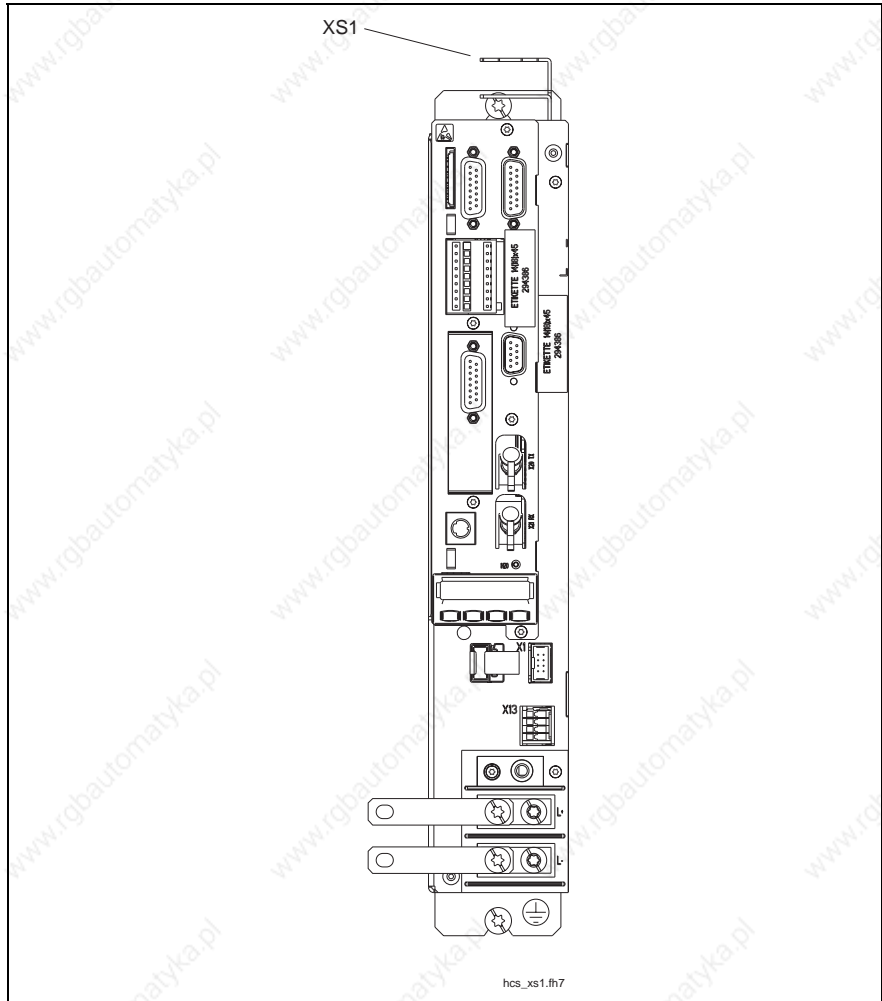

Fig. 6-82: Shield connection XS1

Connection for shields of lines connected to the control section (only for lines with connectors, which do not have their own shield connection).

**Note:** Always connect shields of control lines with a large metal-to-metal contact surface.



**CAUTION**

**Risk of damage caused by high temperature of outlet air!**

⇒ Observe outlet temperatures at the top of the drive controllers.

**XS2, Shield Connection HCS02 (Motor Cable)**

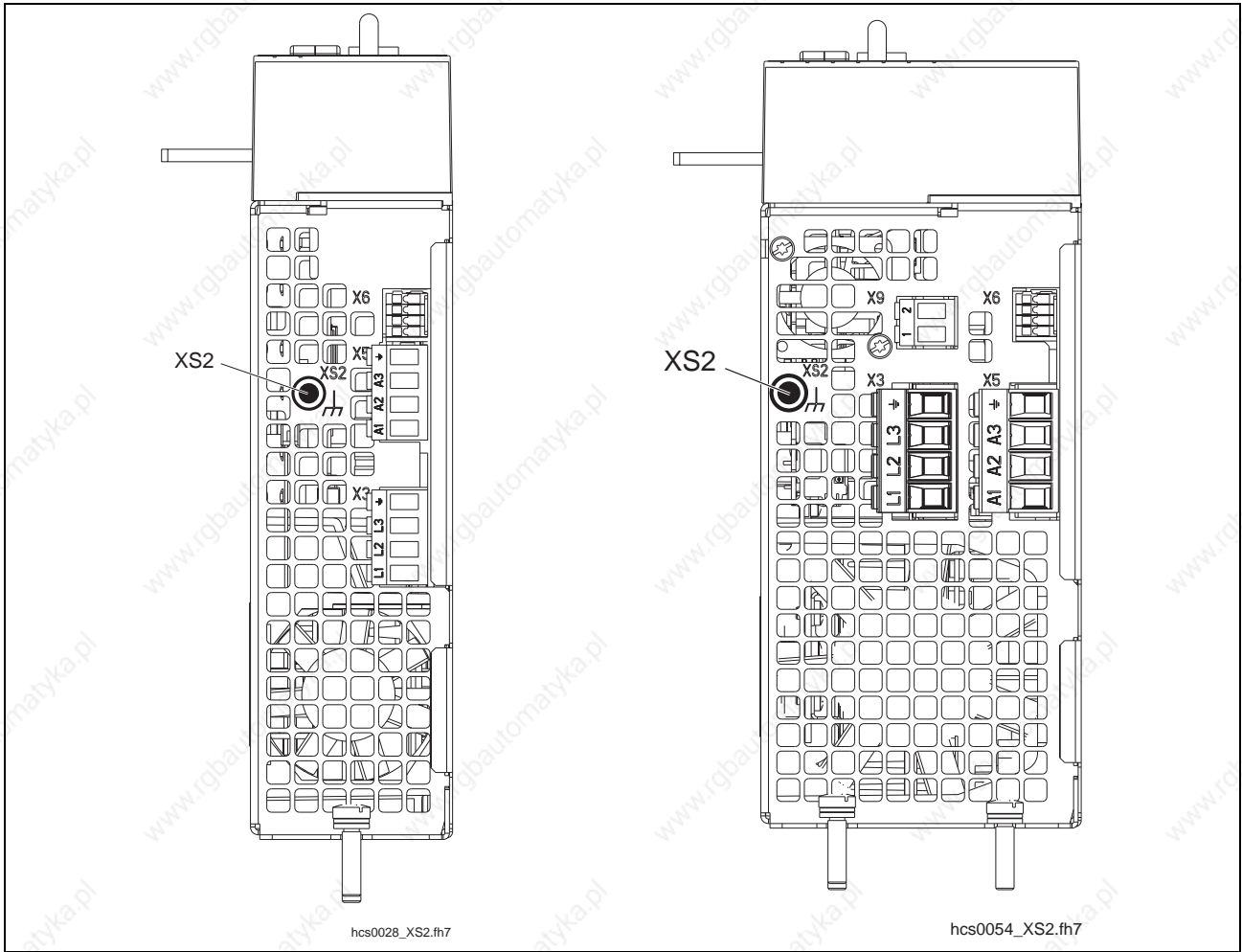

Fig. 6-83: XS2

XS2 is used for mounting the accessory HAS02.1 for shield connection of the motor cable.



**Control Sections BASIC OPENLOOP - CSB01.1N-FC**

Front View with Connections at Basic Circuit Board:



Front view	Conne- ction point	Strande d wire [mm <sup>2</sup> ]	AWG	Tighte ning torque [Nm]	Description	Figure
	X31 / X32	0,08-1,5	28-14	-	digital and analog inputs/outputs; voltage input (24V, 0V)	 DA000051v01_nn.FH9
	X11 / X12	0,08-1,5	28-14	-	relay contacts	 DA000050v01_nn.FH9
	X35 / X36	0,08-1,5	28-14	-	analog inputs / outputs ; voltage output (24V, 0V)	 DA000052v01_nn.FH9
	X2	0,25-0,5	-	-	serial interface	 DA000049v01_nn.FH9
	H1	-	-	-	interface for control panel	-

see also chapter "Connections with Spring Terminals"

Fig. 6-84: Connections BASIC OPENLOOP

## Functions

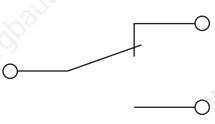
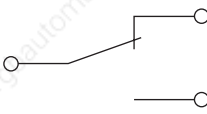
**Note:** Factory settings depend on the firmware. Following settings are valid for firmware MPx04.

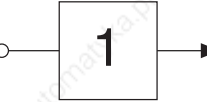
Function	Connec- tion	Factory setting	Nominal data	Technical data	
relay contact Rel 3   <small>DA000016v01_nn.FH9</small>	no Rel 3	X11.3	"speed reached", S-0-0013	AC250V /2A DC30V /1A	relay contact type 1
	com Rel 3	X11.4			
	nc Rel 3	X11.5			
relay contact Rel 2   <small>DA000016v01_nn.FH9</small>	no Rel 2	X12.3	"Ready", P-0-0115	AC250V /2A DC30V /1A	
	com Rel 2	X12.4			
	nc Rel 2	X12.5			
relay contact Rel 1   <small>DA000017v01_nn.FH9</small>	no Rel 1	X12.1	ready for operation, P-0-0115	AC250V /2A DC30V /1A	
	no Rel 1	X12.2			
digital inputs   <small>DA000022v01_nn.FH9</small>	E1	X31.3	"clear error", S-0-0099	24 V / 3 mA	digital inputs
	E2	X31.4	"drive ON", P-0-4028		
	E3	X31.5	"velocity cmd value from memory of fixed values", P-0-1200		
	E4	X31.6	"velocity cmd value from memory of fixed values", P-0-1200		
	E5	X31.7	"velocity cmd value from memory of fixed values", P-0-1200		
	E8	X32.6	"E-Stop", P-0-0223		
	E9	X32.7	"velocity cmd value from memory of fixed values", P-0-1200		
	E10	X32.8	"velocity cmd value from memory of fixed values", P-0-1200		

Function		Conne ction	Factory setting	Nominal data	Technical data		
analog inputs	voltage input	EAn1+	X32.4		+/- 10 V	analog inputs type 1	
		EAn1-	X32.5				
	voltage input	EAn2+	X32.1				
		EAn2-	X32.2				
	current input	AI1+	X36.1		0...20 mA		analog inputs type 3
		AI1-	X36.2				
current input	AI2+	X36.3					
	AI2-	X36.4					
analog output	voltage output	AN1	X32.9		0...+10 V	analog outputs type 1	
	reference potential for analog voltage output	A_GND	X32.3				
analog output	voltage output	AN2	X35.3		0...+10 V	analog outputs type 1	
	reference potential for analog voltage output	A_GND	X35.4				
input for voltage supply of digital inputs	supply of digital inputs	+24V	X31.8			DC 19...30 V; max. 0,1A	
		0V	X31.9				
output (source) for voltage supply of digital inputs	connect supply (source) of digital inputs with X31.8 or X31.9	+24V	X35.1			DC 19...30 V max. 0,1A; protected against polarity reversal; short- circuit proof	
		0V	X35.2				
serial interface			X2		corresponds to RS232		

Fig. 6-85: Functions BASIC OPENLOOP

**BASIC PROFIBUS - CSB01.1N-PB**

**Front View with Connections at Basic Circuit Board**

Front view	Conne- ction point	Strande d wire [mm²]	AWG	Tighte ning torque [Nm]	Description	Figure
	X8	0,25-0,5	-	-	encoder evaluation ENS	 DA000053v01_nn.FH9
	X31 / X32	0,08-1,5	28-14	-	digital inputs/outputs; voltage input (24V, 0V)	 DA000051v01_nn.FH9
	X41	0,25-0,5	-	-	<b>optional:</b> starting lockout	 DA000054v01_nn.FH9
	X30	0,08-0,5	-	-	master communication PROFIBUS	 DA000054v01_nn.FH9
	X2	0,25-0,5	n.s.	-	serial interface	 DA000049v01_nn.FH9
	H1	-	-	-	interface for control panel	-

see also chapter "Connections with Spring Terminals"

Fig. 6-86: BASIC PROFIBUS

### Functions

**Note:** Factory settings depend on the firmware. Following settings are valid for firmware MPx04.

**Note:** Observe that the connections X32.6, X32.7 and X32.8 can be configured as digital input (E8, E9, E10) or digital output (A8, A9, A10).





Function		Con- nection point	Factory setting	Nominal data	Technical data	
master communication	PROFIBUS	PB	X30		12 Mbaud	
encoder interfaces	ENS		X8		DC11V6, 300 mA see Technical Data Optional Module ENS	
relay contact	 DA000017v01_nn.FH9	Rel 1	X31.1	"ready for operation" P-0-0115	DC24V / 1A	relay contact type 2
		Rel 1	X31.2			
digital inputs	 DA000022v01_nn.FH9	E1	X31.3	"probe 1" S-0-0401	can be configured as probe; 24 V / 3 mA; typ. 1us	digital inputs
		E2	X31.4			
	 DA000022v01_nn.FH9	E3	X31.5	"travel range limit switch" P-0-0222	24 V / 3 mA	digital inputs
		E4	X31.6	"travel range limit switch" P-0-0222		
		E5	X31.7	"home switch" S-0-0400		
		E8	X32.6	"E-Stop" P-0-0223		
		E9	X32.7			
		E10	X32.8			
digital outputs	 DA000024v01_nn.FH9	A8	X32.6		24 V / 0,5 A	digital outputs
		A9	X32.7			
		A10	X32.8			
voltage supply of digital inputs/outputs	voltage supply of digital inputs/outputs	+24V	X31.8			DC 19...30 V; max. 1,1A
		0V	X31.9			
serial interface	RS232		X2			serial interface
<b>optional:</b> starting lockout			X41			see Optional Module Starting Lockout

Fig. 6-87: Functions BASIC PROFIBUS

**Serial Interface (RS232)**

The serial interface (RS232) is required for programming, parameterization and diagnosis during commissioning and servicing.

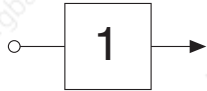
Connection point	Type	No. of poles	Stranded wire [mm <sup>2</sup> ]	Description	Figure
X2	MiniDin, female (device)	8	0,25-0,5	serial interface	

Fig. 6-88: Connections

Pin	Signal	Function
1	RTS	Request to send
2	CTS	Clear to send
3	TxD	Transmit Data
4	GND	reference potential
5	RxD	Receive Data
6	V <sub>cc</sub>	supply voltage
7	n.c.	n.c.
8	n.c.	n.c.

Fig. 6-89: Pin assignment of serial interface

**Serial Interface to PC with 9-Pin SUB-D:**

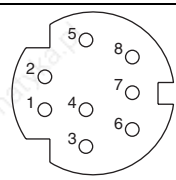
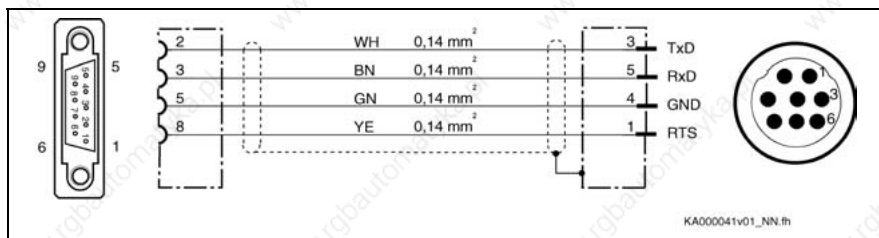

Fig. 6-90: Connection of serial interface to PC with 9-pin SUB-D

**Note:** For **direct** connection to the serial interface, use our cable IKB 0041.

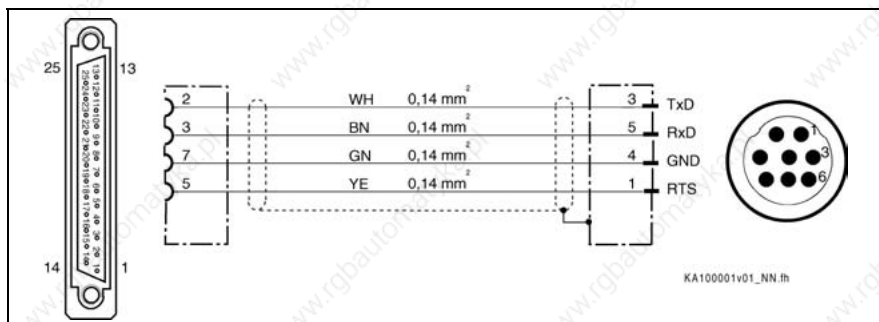

Fig. 6-91: Connection of serial interface to PC with 25-pin SUB-D

## Accessories HAS

## Overview

Gerät (Device)	Breite (Width) (mm)	HAS01						
		HAS01.1-105-072-CN	HAS01.1-065-NNN-CN	HAS01.1-105-NNN-CN	HAS01.1-125-072-CN	HAS01.1-125-NNN-CN	HAS01.1-225-072-CN	HAS01.1-225-NNN-CN
HCS02.1E-W0012	65		X					
HCS02.1E-W0028	65		X					
HCS02.1E-W0054	105	X		X				
HCS02.1E-W0070	105	X		X				
HCS03.1E-W0070	125				X	X		
HCS03.1E-W0100	225						X	X
HCS03.1E-W0150	225						X	X
HCS03.1E-W0210	350							X

DL000088v01\_nn.fh11

Fig. 6-92: Accessories HAS01

Gerät (Device)	Breite (Width) (mm)	HAS02						
		HAS02.1-002-NNN-NN	HAS02.1-003-NNN-NN	HAS02.1-004-NNN-NN	HAS02.1-005-NNN-NN	HAS02.1-006-NNN-NN	HAS02.1-007-NNN-NN	HAS02.1-008-NNN-NN
HCS02.1E-W0012	65	X						
HCS02.1E-W0028	65	X						
HCS02.1E-W0054	105	X						
HCS02.1E-W0070	105	X						
HCS03.1E-W0070	125			X				X
HCS03.1E-W0100	225				X			
HCS03.1E-W0150	225				X			
HCS03.1E-W0210	350						X	
HNK01.1A-...-E0050	125					X		
HNK01.1A-...-E0080	225						X	
HNK01.1A-...-E0106	225						X	
HNK01.1A-...-E0146	350							X
HMF01.1A-...-0070	125							X

DL000089v01\_nn.fh11

Fig. 6-93: Accessories HAS02







---

**Note:** Please observe that the contact bars of the basic accessories HAS01 are used for connection to the drive controller to the **left side**.

---

### Applications

The HAS01 accessories are used to

- fasten the drive controllers on a mounting surface,
- interconnect the DC bus connections of drive controllers,
- connect the 24V supply of drive controllers of the Rexroth IndraDrive M range,
- establish the connection of the equipment grounding conductors from drive controller to drive controller or supply module,
- increase the current carrying capacity of the contact bars in the DC bus.

### Scope of Supply

The basic accessories HAS01 **without** contact bars is contained in the standard scope of supply of the HCS02 drive controllers.

### Further Accessories

---

**Note:** You find a complete overview of available accessories in the Project Planning Manual "Rexroth IndraDrive Drive System".

---

### Accompanying Note

The accessories will be delivered with a accompanying note. The accompanying note shows the parts of the accessories.

Made in Germany  
109-1253-4817-06

**Rexroth  
Bosch Group**

## HAS01.1-350-072-CN



R911306668

Stck	Benennung	MN
1	SECHSKANTSCHRAUBE ISO4017-M8X25-8.8 &	R911292421
6	SECHSKANTSCHRAUBE ISO4017-M10X30-8.8A1E	R913000050
15	SCHR-LIN-M 6,0X25,0-K-8.8-ISO7045-ZN-Z41	R911276873
2	SCHR-LIN-M 3,0X 8,0-T-8.8-ISO7045-ZN-ML+	R911294165
1	SCHILD-KLEBE UL-CSA WARNHINWEIS EN/FR 30	R911309089
4	SCHIENE-VERBINDUNG HAS01.1-350-072 ISOL.	R911309954
2	SCHIENE-VERBINDUNG HAS01.1-032-042	R911311751
6	SCHEIBE 10,50X 20,00X 2,00 DIN 125 A	R911213277
1	LASCHE HMD/HMS01.1 ERDUNG	R911294924
1	LASCHE HCS03.1E-W0210 ERDUNG	R911025419
5	KAB-BIND-D045-B4,8-C085-N220-TR-PA-*****	R911222614
6	FEDERRING DIN127-B10-FST &	R911213251
2	ENDSTUECK HAS01.1 SCHIENE-VERBINDUNG	R911311982

**BEIPACKZETTEL HAS01.1-350-072-CN**

Stck	Benennung	MN
1	LASCHE HMD/HMS01.1 ERDUNG	R911294924
6	SCHEIBE 10,50X 20,00X 2,00 DIN 125 A	R911213277
2	SCHIENE-VERBINDUNG HAS01.1-032-042	R911311751
4	SCHIENE-VERBINDUNG HAS01.1-350-072 ISOL.	R911309954
1	SCHILD-KLEBE UL-CSA WARNHINWEIS EN/FR 30	R911309089
2	SCHR-LIN-M 3,0X 8,0-T-8.8-ISO7045-ZN-ML+	R911294165
15	SCHR-LIN-M 6,0X25,0-K-8.8-ISO7045-ZN-Z41	R911276873
6	SECHSKANTSCHRAUBE ISO4017-M10X30-8.8A1E	R913000050
1	SECHSKANTSCHRAUBE ISO4017-M8X25-8.8 &	R911292421

Stck	Benennung	MN
2	ENDSTUECK HAS01.1 SCHIENE-VERBINDUNG	R911311982
6	FEDERRING DIN127-B10-FST &	R911213251
5	KAB-BIND-D045-B4,8-C085-N220-TR-PA-*****	R911222614
1	LASCHE HCS03.1E-W0210 ERDUNG	R911025419

Datum	2004-02-28	Benennung	BEIPACKZETTEL HAS01.1-350-072-CN
Name	Hirt / Steven	Material-Nr.	R911306678
Zeich-Nr.	109-1253-4227-07	Ers.durch	..
Datei	DB166387	AEM-Nr.	5-017509

Fig. 6-95: Accompanying note (example)

### Mounting the Parts "Bar" and "End Piece" from the HAS01 Accessories

The parts "bar" and "end piece" increase the current carrying capacity of the DC bus connection by reducing the involved contact resistances.

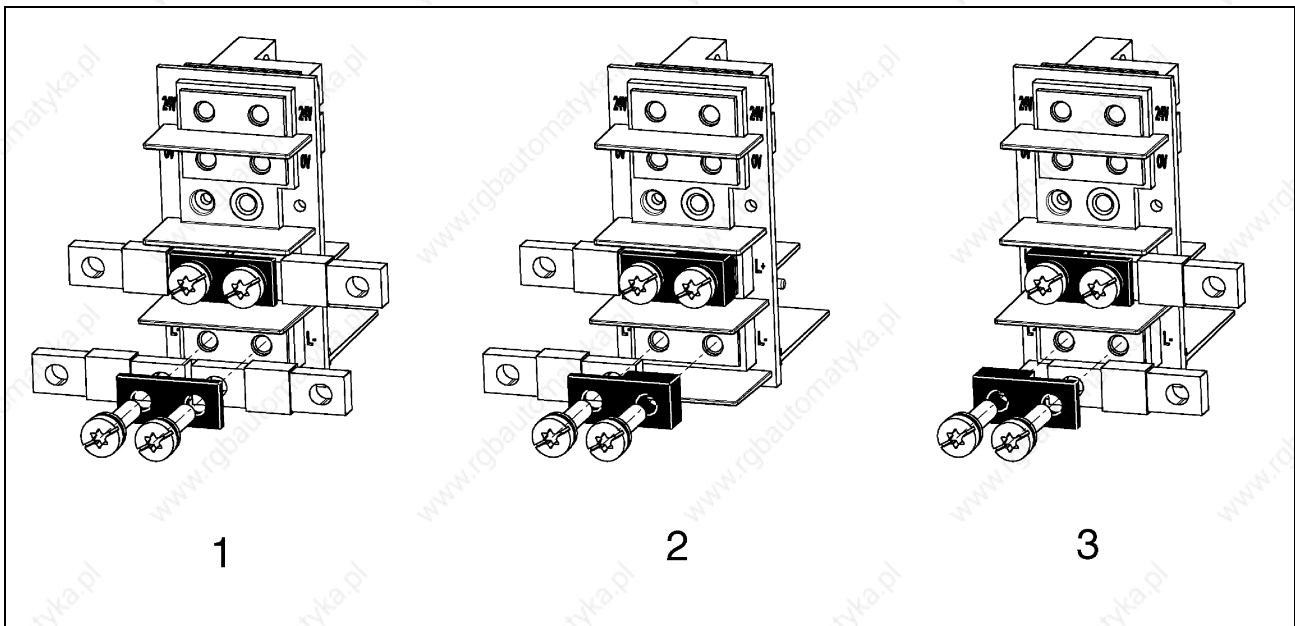

- 1: bar  
 2: end pieces (right end)  
 3: end pieces (left end)

Fig. 6-96: Mounting bar and end piece from HAS01

- Ad 1: Use the bars contained in all HAS01.1-\*\*\*-072-\*\* at L+ and L- as illustrated above.
- Ad 2 and 3: Use the end pieces contained in all HAS01.1-350-\*\*\*.\*\* and HAS01.1-200-\*\*\*.\*\* at the right and left ends of the DC bus connections in the drive system.

### Shield Connection HAS02

Accessories for appropriate connection of the motor cable to the drive controller, especially the shield connection of the motor cable.

There are appropriate HAS02 available for the different connection cross sections of the drive controllers.

### Type Code

Abbrev. Column	1	2	3	4	5	6	7	8	9	0	1	2	3	4	5	6	7	8	9	0	2	0	1	2	3	4	5	6	7	8	9	0	3	0	1	2	3	4	5	6	7	8	9	0	4	0	
Example:	H	A	S	0	2	.	1	-	0	0	1	-	N	N	N	-	N	N																													
<b>1. Product</b>																																															
1.1 Accessories																																															
IndraDrive ... = HAS																																															
<b>2. Line</b>																																															
2.1 Shield connection. ... = 02																																															
<b>3. Design</b>																																															
3.1 1 ..... = 1																																															
<b>4. Device assignment</b>																																															
4.1 HMS01.1N-W0020 ..... = 001																																															
4.2 HMS01.1N-W0036 ..... = 001																																															
4.3 HMS01.1N-W0054 ..... = 002																																															
4.4 HMS01.1N-W0070 ..... = 002																																															
4.5 HMD01.1N-W0020 ..... = 002																																															
4.6 HMD01.1N-W0036 ..... = 002																																															
4.7 HCS02.1E-W0012 ..... = 002																																															
4.8 HCS02.1E-W0028 ..... = 002																																															
4.9 HCS02.1E-W0054 ..... = 002																																															
4.10 HCS02.1E-W0070 ..... = 002																																															
4.11 HMS01.1N-W0150 ..... = 003																																															
4.12 HMS01.1N-W0210 ..... = 003																																															
4.13 HCS03.1E-W0070 ..... = 004																																															
4.14 HCS03.1E-W0100 ..... = 005																																															
4.15 HCS03.1E-W0150 ..... = 005																																															
4.16 HNK01.1A-A075-E0050 ..... = 006																																															
4.17 HNK01.1A-A075-E0080 ..... = 007																																															
4.18 HNK01.1A-A075-E0106 ..... = 007																																															
4.19 HCS03.1E-W0210 ..... = 008																																															
4.20 HNK01.1A-A075-E0146 ..... = 009																																															
4.21 HMS02.1N-W0028 ..... = 010																																															
4.22 HMS02.1N-W0054 ..... = 011																																															
4.23 HCS04.1E-X0500 ..... = 012																																															
<b>5. Other feature</b>																																															
5.1 none ..... = NNN																																															
<b>6. Other design</b>																																															
6.1 none ..... = NN																																															

DT000004v01\_en.fh

Fig. 6-97: Type code HAS02.1

### Applications

The HAS02 accessories are used to

- provide the motor connection cables with a strain relief,
- connect the shield of the motor connection cables to the drive controller.

### Scope of Supply

The HAS02 accessories are available as an option, they are not part of the standard scope of supply.

Made in Germany  
109-1228-4815-02







## HAS02.1-002-NNN-NN



R911306106

2	SCHR-LIN-M 6,0X12,0-K-8.8-ISO7045-ZN-Z41	R911252551
2	SCHELLE-SCHL-S012*022-B12-ZN-SW7*S-3017	R911274471
1	HALTERUNG HCS02.1 KABELD. 12-18	R911305852
1	BLECH HCS02.1 KABELBEFESTIGUNG	R911305851
Stck	Benennung	MN

BEIPACKZETTEL HAS02.1-002-NNN-NN		
Stck	Benennung	MN
1 DB163070	BLECH HCS02.1 KABELBEFESTIGUNG 	R911305851 1:5
1 DB163246	HALTERUNG HCS02.1 KABELD. 12-18 	R911305852 7:20
2 DB_46879	SCHELLE-SCHL-S012*022-B12-ZN-SW7*S-3017 	R911274471 1:2
2 DB_38405	SCHR-LIN-M 6,0X12,0-K-8.8-ISO7045-ZN-Z41 	R911252551 1:1

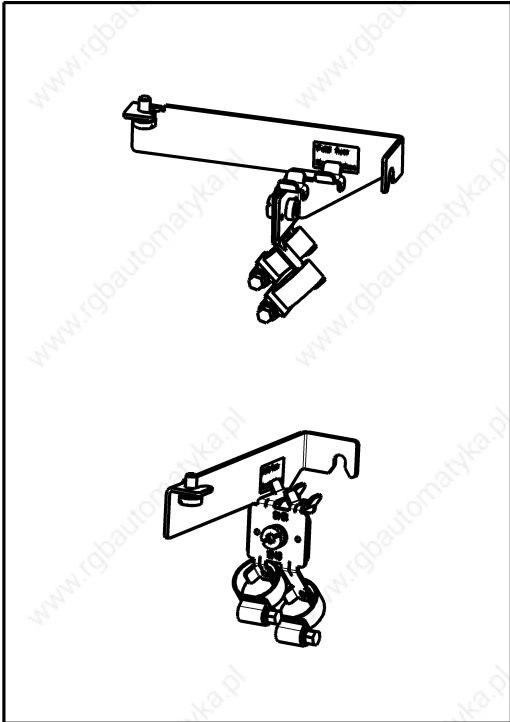

Datum	2004-01-30	Benennung	
Name	Born	BEIPACKZETTEL HAS02.1-002-NNN-NN	
Material-Nr.	R911306107	Zeich-Nr.	109-1228-4231-02
Datei	DB165311	Ers.durch	..
		ABM-Nr.	5-07273

Fig. 6-98: Accompanying note

Made in Germany  
109-1253-4819-01







## HAS02.1-004-NNN-NN

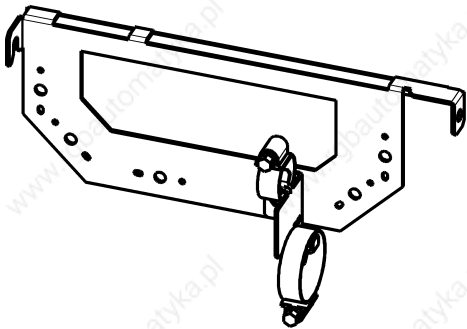

R911306720

I	SCHR-LIN-M 6,0X12,0-K-8.8-1S07045-ZN-Z41	R911252551
I	SCHIRMWINKEL	R911024542
I	SCHELLE-SCHL-S023*035*B12-ZN-SW7*S-3017	R911274472
I	SCHELLE-SCHL-S012*022-B12-ZN-SW7*S-3017	R911274471
I	HALTERUNG HMS01.1 KABELD. 12-35	R911296081
Stck	Benennung	MN

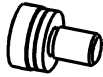

BEIPACKZETTEL HAS02.1-004-NNN-NN		
Stck	Benennung	MN
DB_143411	 HALTERUNG HMS01.1 KABELD. 12-35	R911296081  7:20
DB_46879	 SCHELLE-SCHL-S012*022-B12-ZN-SW7*S-3017	R911274471  1:2
DB_46868	 SCHELLE-SCHL-S023*035*B12-ZN-SW7*S-3017	R911274472  1:2
DB_165369	 SCHIRMWINKEL	R911024542  1:5
DB_38105	 SCHR-LIN-M 6,0X12,0-K-8.8-1S07045-ZN-Z41	R911252551  1:1

Datum	2004-03-02	Benennung		
Name	Hirt / Steven	BEIPACKZETTEL HAS02.1-004-NNN-NN		
Material-Nr.	R911306720	Zeich-Nr.	109-1253-4229-01	
Datei	DB166622	Ers.durch	..	ABM-Nr. 5-07273

Fig. 6-99: Accompanying note

Made in Germany  
109-1253-4820-01



## HAS02.1-005-NNN-NN



R911306721

1	WINKEL HMS01.1-W0150 ABSCHIRMANSCHLUSS	R911296068
4	SCHR-LIN-M 6,0X12,0-K-8.8-ISO7045-ZN-Z41	R911252551
1	SCHELLE-SCHL-S032*050-B12-ZN-SW7*S-3017	R911296565
2	SCHELLE-SCHL-S023*035*B12-ZN-SW7*S-3017	R911274472
1	ABSCHIRMANSCHLUSS	R911024379
Stck	Benennung	MN

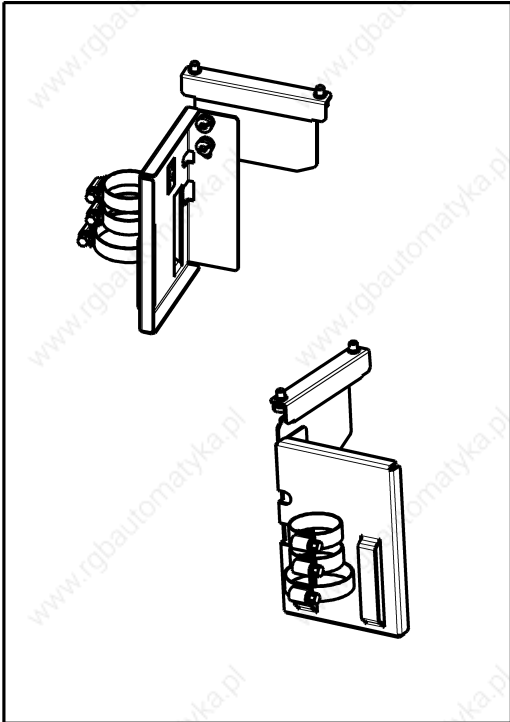

BEIPACKZETTEL HAS02.1-005-NNN-NN

Stck	Benennung	MN
DB166371	1 ABSCHIRMANSCHLUSS	R911024379 1:4
DB_48868	2 SCHELLE-SCHL-S023*035*B12-ZN-SW7*S-3017	R911274472 1:2
DB188743	1 SCHELLE-SCHL-S032*050-B12-ZN-SW7*S-3017	R911296565 7:20
DB_38405	4 SCHR-LIN-M 6,0X12,0-K-8.8-ISO7045-ZN-Z41	R911252551
DB14663	1 WINKEL HMS01.1-W0150 ABSCHIRMANSCHLUSS	R911296068 1:5

Datum	2004-03-02	Benennung
Name	Hirt / Steven	BEIPACKZETTEL HAS02.1-005-NNN-NN
Material-Nr.	R911306725	Zeich-Nr. 109-1253-4230-01
Datei	DB166623	Ers.durch .. AEM-Nr. 5-07273

Fig. 6-100: Accompanying note



Made in Germany









## HAS02.1-008-NNN-NN



R911309579

4	SECHSKANTSCHRAUBE ISO4017-M6X12-8-8-A2C	R900014492
4	SCHR-LIN-M 6,0X12,0-K-8-8-ISO7045-ZN-Z41	R911252551
1	SCHIRMAUFLAGE HCS210	0025285
4	SCHELLE-SCHL-S023*035*B12-ZN-SW7*S-3017	R911274472
4	SCHEIBE 6,40X 12,00X 1,60 DIN 125	R911212427
2	HALTER SCHIRMAUFLAGE HCS210	0025286
4	FEDERRING B 6,0 DIN 127 ZN	R911213515
Stck	Benennung	MN

BEIPACKZETTEL HAS02.1-008-NNN-NN																						
Stck	Benennung	MN																				
4 DB_53462	FEDERRING B 6,0 DIN 127 ZN 	R911213515 1:1																				
2 DB178733	HALTER SCHIRMAUFLAGE HCS210 	0025286 3:20																				
4 DB_42275	SCHEIBE 6,40X 12,00X 1,60 DIN 125 	R911212427 1:1																				
4 DB_40668	SCHELLE-SCHL-S023*035*B12-ZN-SW7*S-3017 	R911274472 1:2																				
1 DB178731	SCHIRMAUFLAGE HCS210 	0025285 3:20																				
4 DB_38405	SCHR-LIN-M 6,0X12,0-K-8-8-ISO7045-ZN-Z41 	R911252551 1:1																				
4 DB178750	SECHSKANTSCHRAUBE ISO4017-M6X12-8-8-A2C 	R900014492 1:1																				
<table border="1" style="width: 100%; border-collapse: collapse;"> <tr> <td>Datum</td> <td>2004-11-08</td> <td>Benennung</td> <td>BEIPACKZETTEL HAS02.1-008-NNN-NN</td> </tr> <tr> <td>Name</td> <td>Sleven</td> <td>Material-Nr.</td> <td>109-1253-4233-00</td> </tr> <tr> <td>Material-Nr.</td> <td></td> <td>Zeich-Nr.</td> <td>109-1253-4233-00</td> </tr> <tr> <td>Datei</td> <td>DB178779</td> <td>Ers.durch</td> <td>...</td> </tr> <tr> <td></td> <td></td> <td>AEM-Nr.</td> <td>...</td> </tr> </table>			Datum	2004-11-08	Benennung	BEIPACKZETTEL HAS02.1-008-NNN-NN	Name	Sleven	Material-Nr.	109-1253-4233-00	Material-Nr.		Zeich-Nr.	109-1253-4233-00	Datei	DB178779	Ers.durch	...			AEM-Nr.	...
Datum	2004-11-08	Benennung	BEIPACKZETTEL HAS02.1-008-NNN-NN																			
Name	Sleven	Material-Nr.	109-1253-4233-00																			
Material-Nr.		Zeich-Nr.	109-1253-4233-00																			
Datei	DB178779	Ers.durch	...																			
		AEM-Nr.	...																			

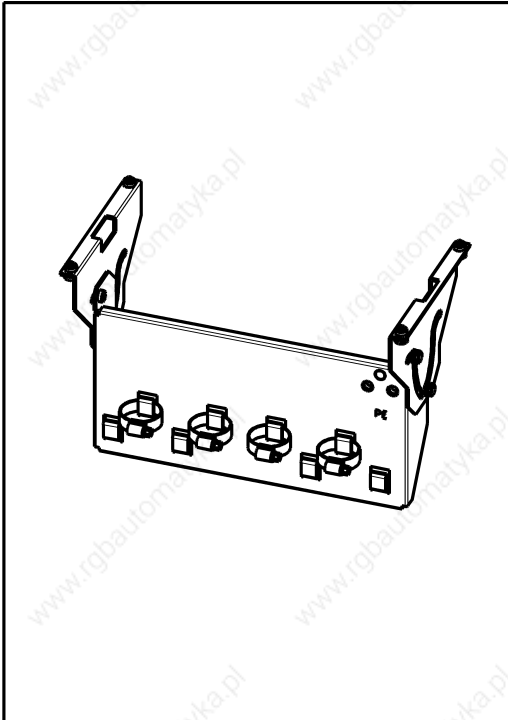

Fig. 6-101: Accompanying note

### Mounting the HAS02 Accessories

The sheet metal of the accessories is screwed to the bottom of the drive controller (see also figure below):

- Unscrew bottom or bottom left fixing screw of drive controller.
- Put sheet metal of accessories to bottom of drive controller and screw down fixing screw of drive controller again.



**CAUTION**

#### Risk of damage to the drive controller caused by too long screws!

⇒ Exclusively use the supplied screws of a length of **12 mm** for the thread of the shield connection XS2.

- Screw second screw (M6 x 12) in thread XS2 at bottom of drive controller.
- Screw fixing device to sheet metal of accessories according to desired cable routing of motor cable (45° or horizontal). (The figure below illustrates cable routing with 45°.)
- According to diameter of motor cable, fix motor cable to corresponding support of fixing device (12-18 mm or 19-30 mm) with a clip. Make sure that shield of motor cable has good contact with fixing device.

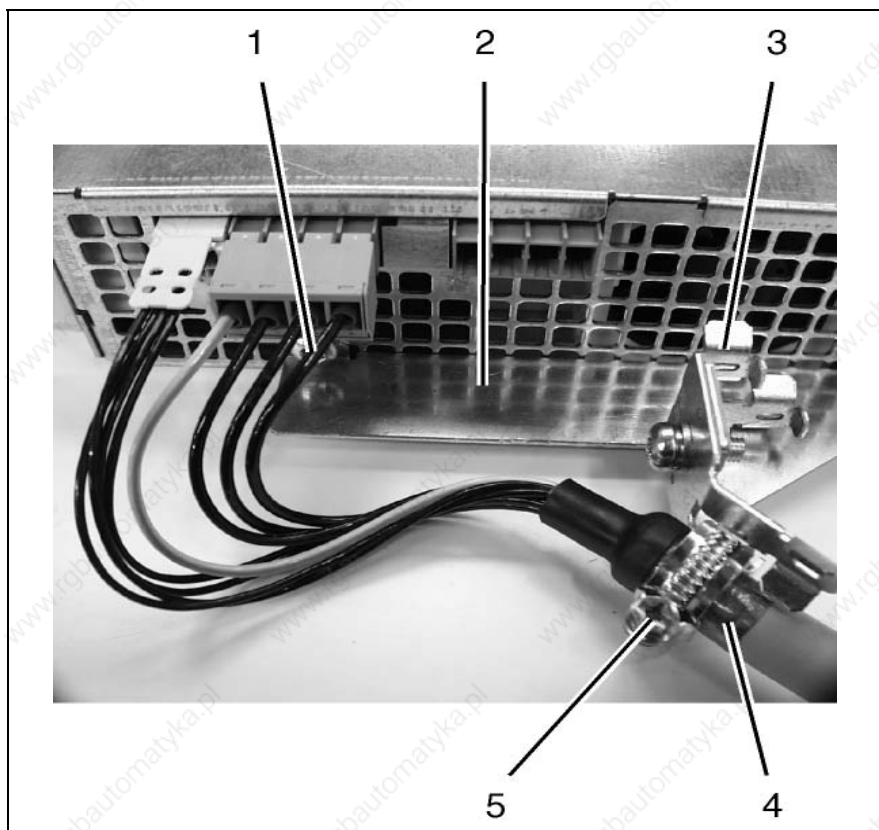

- 1: screw in thread XS2  
 2: sheet metal of accessories  
 3: fixing device  
 4: shield of motor cable  
 5: clip

Fig. 6-102: Shield connection of motor cable

**Mounting Shield Connection  
HAS02.1-004-NNN-NN to Drive  
Controller HCS03.1E-W0070:**

1. By means of supplied screws, fasten shield angle steel to bottom of drive controller.
2. Fix support to shield angle steel as required.

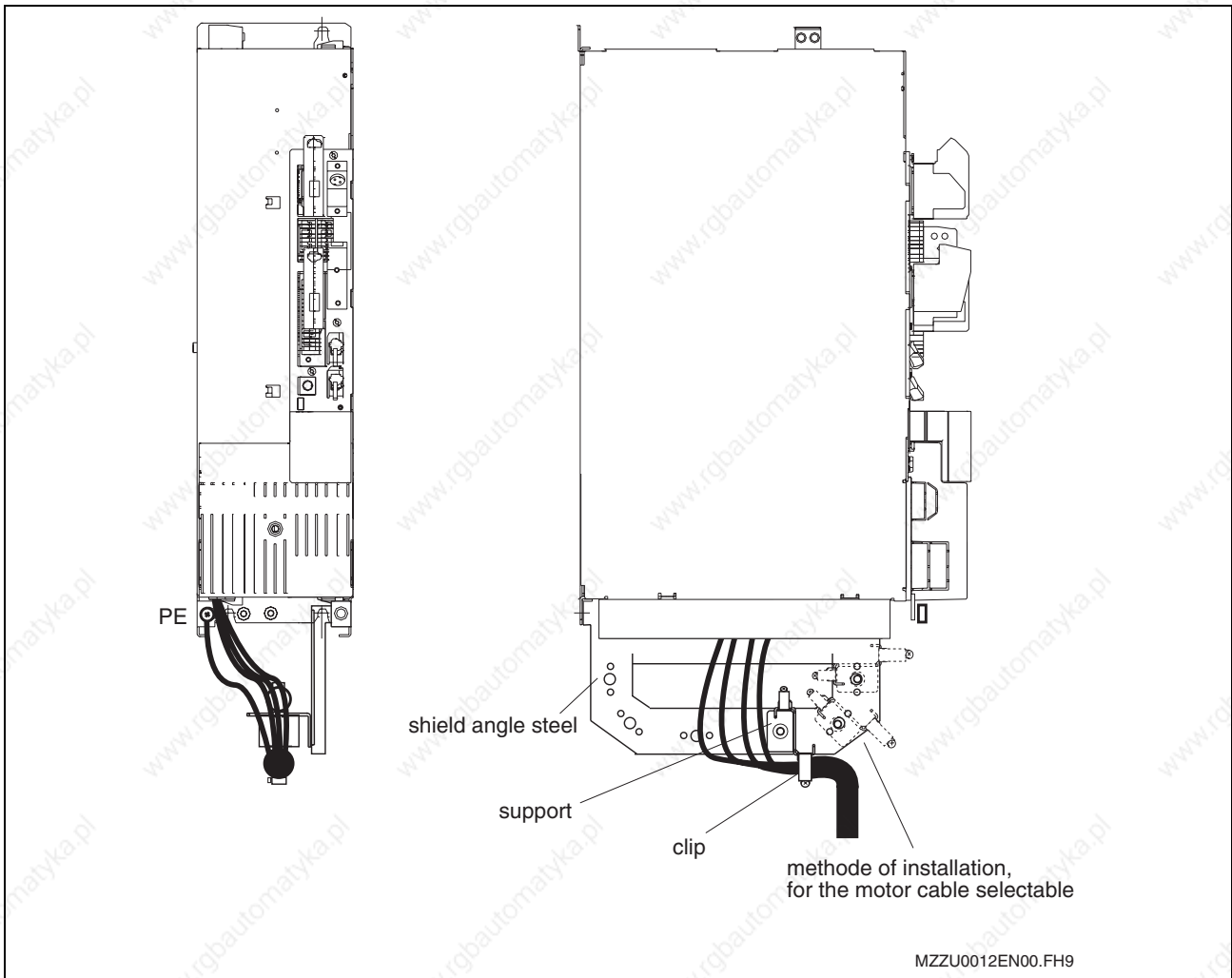

Fig. 6-103: Shielding plate HAS02.1-004-NNN-NN at the bottom of the drive controller HCS03.1E-W0070

3. Fix shield of motor cable to shielding plate with a clip.

**Note:** Adapt the size of the clip to the motor cable cross section.

**Mounting Shield Connection  
HAS02.1-005-NNN-NN to Drive  
Controller HCS03.1E-W0100 /  
150:**

1. Hang up support at guide section at bottom of drive controller and fasten it by means of supplied screws.
2. Screw shielding plate to shield angle steel.

According to required motor cable routing, it is possible to mount angle plate for shield connection in different positions:

- motor cable routed in parallel or
- 45° to bottom of drive controller.

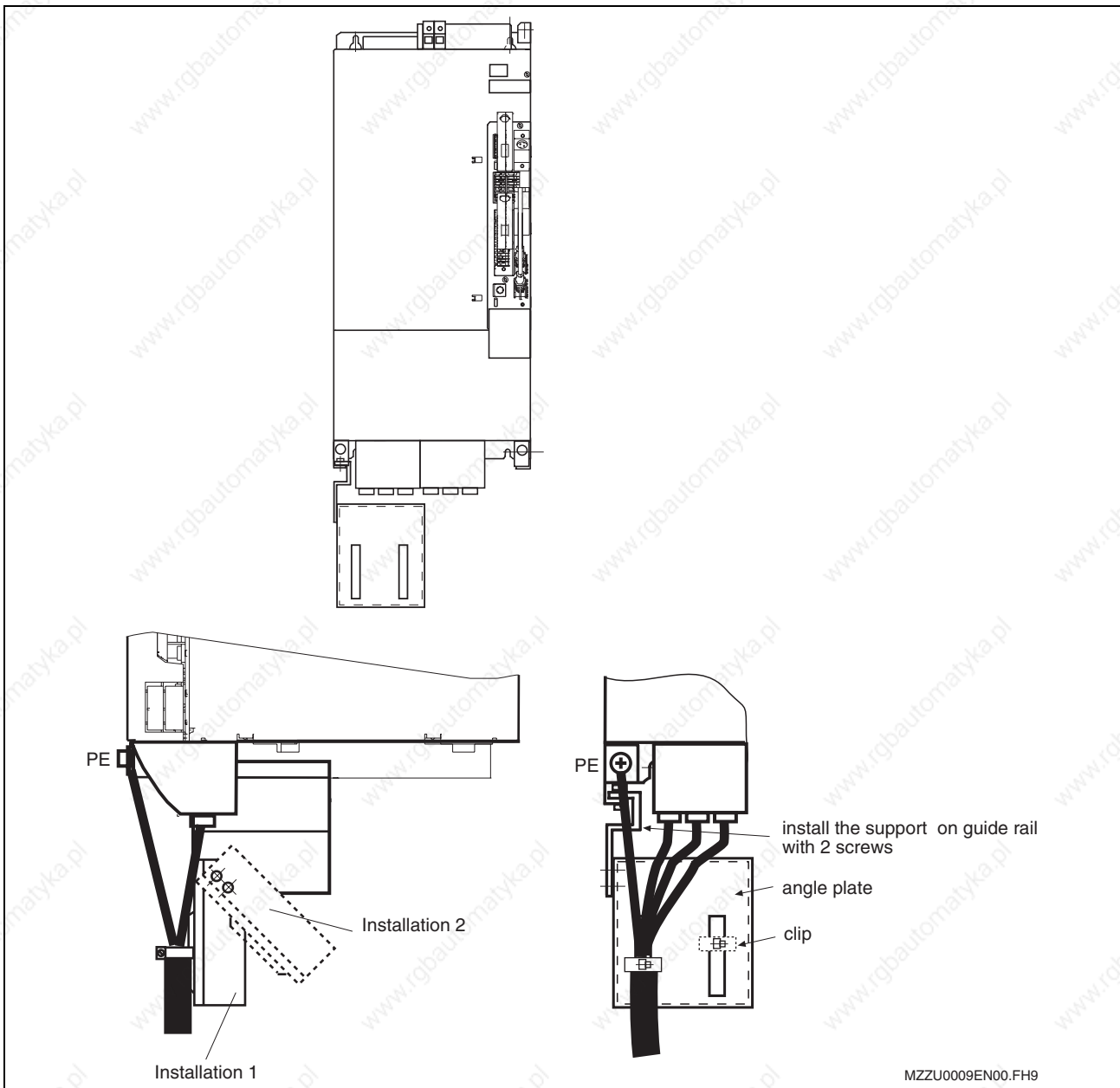

Fig. 6-104: Shielding plate HAS02.1-005-NNN-NN at the bottom of the drive controller HCS03.1E-W0100 / 0150

3. Fix shield of motor cable to shielding plate with a clip.

**Note:** Adapt the size of the clip to the motor cable cross section.

**Mounting Shield Connection  
HAS02.1-008-NNN-NN to Drive  
Controller HCS03.1E-W0210:**

1. By means of supplied screws (from the accessories kit SCHR-LIN-M6,0 x 12,0), fasten support to bottom of drive controller.
2. By means of supplied screws (from the accessories kit SCREW...M6 x 12), fasten shielding plate between the supports.

According to required power supply cable and motor cable routing, it is possible to mount shielding plate for shield connection in different positions.

3. Fix shield of power supply cable and motor cable to shielding plate with a clip.

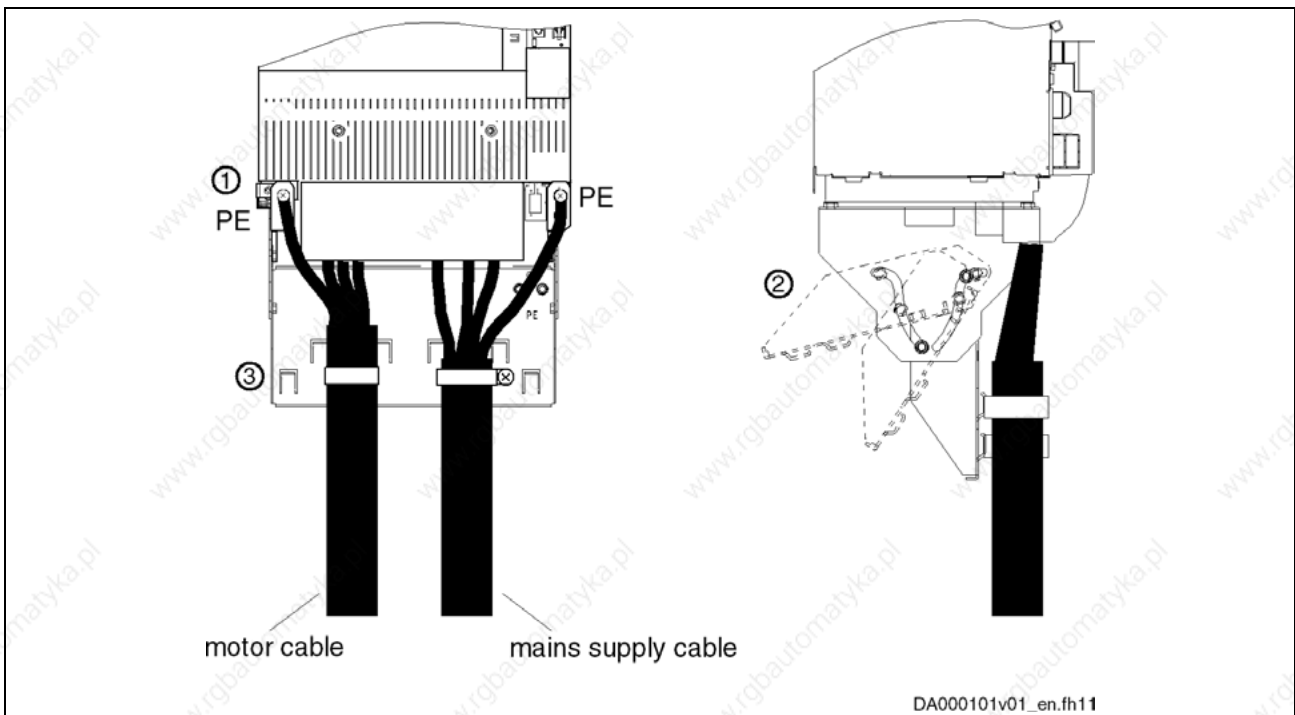

Fig. 6-105: Shielding plate HAS02.1-008-NNN-NN at the bottom of the drive controller HCS03.1E-W0210

**Note:** Adapt the size of the clip to the power supply cable and motor cable cross sections.

### Shield Connection of Motor Cable via Mains Filter

For shield connection of the motor cable at the drive controller via the mains filter, a special shielding plate is available:

**Note:** Using the shielding plate guarantees optimum shield contact of the motor cable. You should therefore **always** use the shielding plate, **where possible**.

The shielding plate is only available as an option.

### Shield Connection of Motor Cable HAS02.1-006-NNN-NN with Mains Filter Mounted:

1. Hang up shielding plate at bottom of mains filter at threaded bolts and fasten with supplied nuts.
2. Screw support to shielding plate.

Clips can be mounted depending on motor cable cross section.

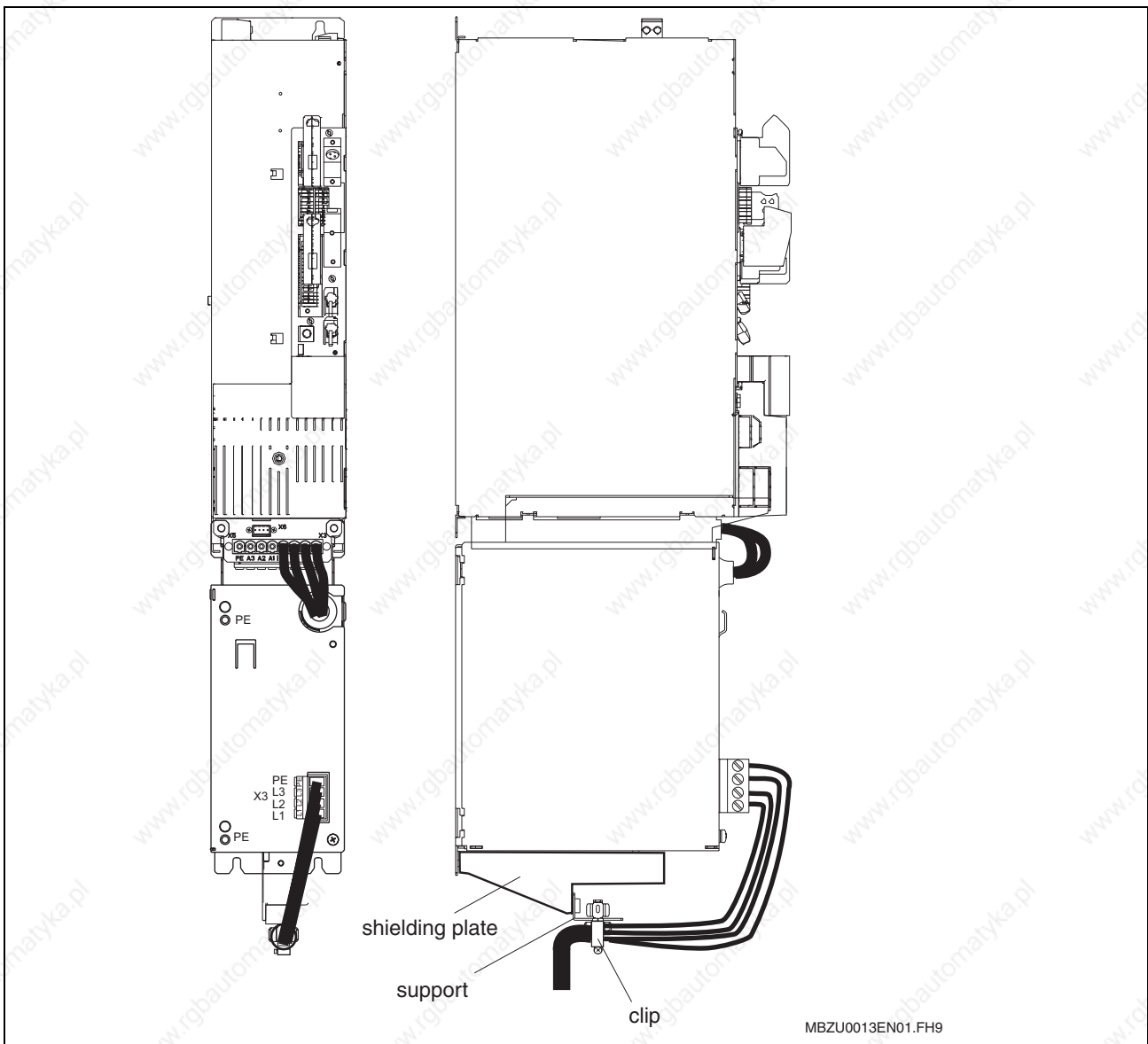

Fig. 6-106: Shielding plate HAS02.1-006-NNN-NN at the bottom of the mains filter (nominal current 50 A)

3. Fix shield of motor cable to shielding plate with a clip.

**Note:** The shield terminals must not be used to provide strain relief.

#### Shield Connection of Power Supply Cable HAS02.1-007-NNN-NN with Mains Filter Mounted

1. Hang up support at bottom of mains filter and fasten it by means of supplied screws.
2. Screw shielding plate of power supply cable to support.

According to required power supply cable routing, it is possible to mount shielding plate in different positions:

- power supply cable routed in parallel or,
- 45° to bottom of mains filter or,
- 90° to bottom of mains filter.

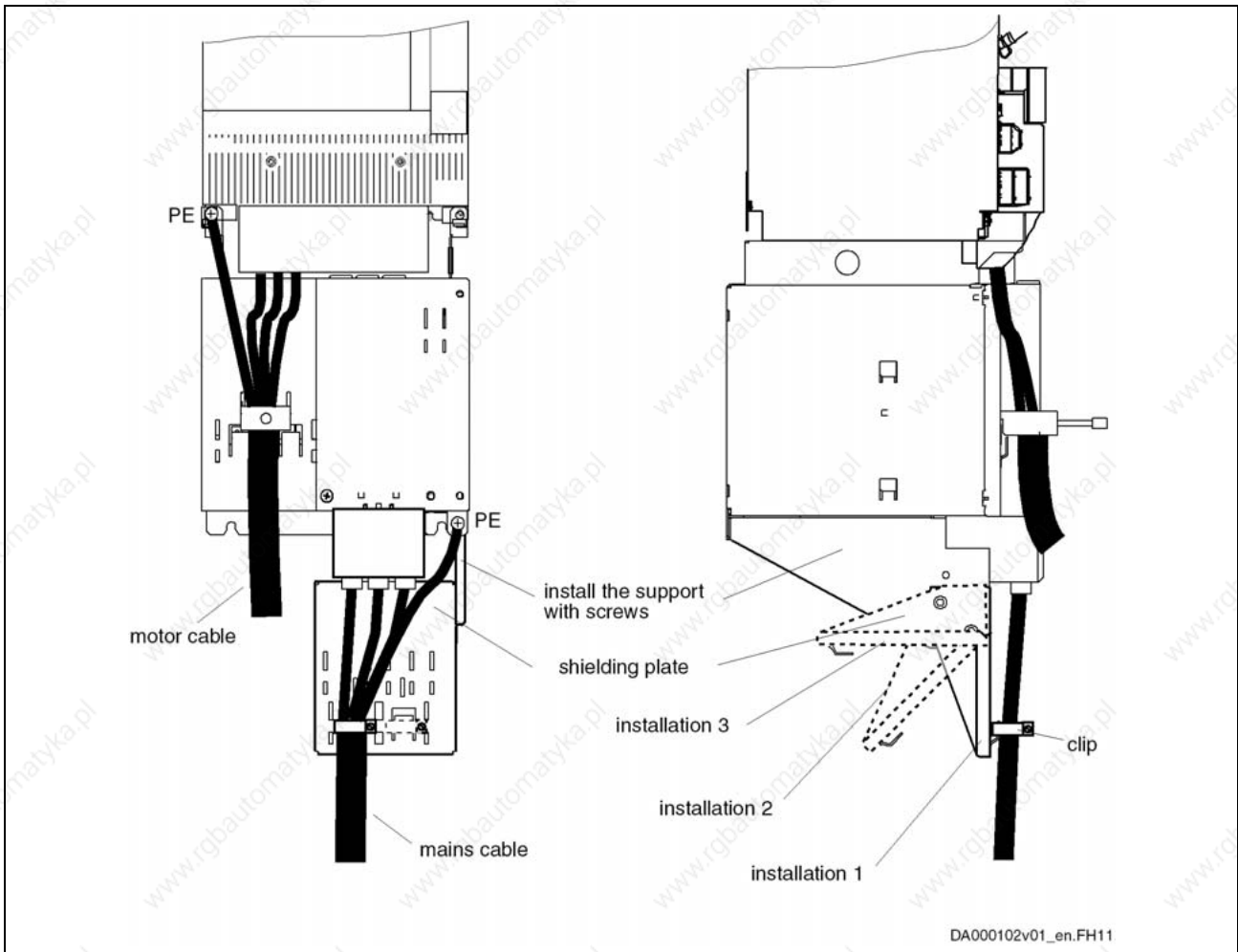

Fig. 6-107: Shielding plate HAS02.1-007-NNN-NN at the bottom of the mains filter (nominal current 80 A / 106 A)

3. Fix shield of power supply cable to front side of mains filter with a clip. For shield connection of the power supply cable at the mains filter, clips of various sizes are available according to cross sections and number of cables, which are hung up to the punched holes.

**Note:** The shield terminals must not be used to provide strain relief.

### Accessories HAS05.1

Type code HAS05.1:

Abbrev. Column	1	2	3	4	5	6	7	8	9	0	1	2	3	4	5	6	7	8	9	0	1	2	3	4	5	6	7	8	9	0
Example:	H	A	S	0	5	.	1	-	0	0	1	-	N	N	N	-	N	N												

  

- 1. Product**
- 1.1 HAS. .... = HAS
  
- 2. Line**
- 2.1 Cable, connectors and adapter. .... = 05
  
- 3. Design**
- 3.1 1. .... = 1
  
- 4. Assignment**
- 4.1 Adapter  
HCS03.1E-W0070 ..... = 001
- 4.2 HMF01.1...0070 ..... = 002
- 4.3 Level emulation Encoder emulation = 003
- 4.4 DC bus, 2 x 50 mm<sup>2</sup>. .... = 004
- 4.5 RS232/RS485 converter ..... = 005
  
- 5. Other features**
- 5.1 none ..... = NNN
- 5.2 Fitting direction : on both sides ..... = NNB
- 5.3 Fitting direction : lefthand ..... = NNL
- 5.4 Fitting direction : righthand ..... = NNR
  
- 6. Other design**
- 6.1 none ..... = NN

  

**to field 4. Assignment**

Adapter: "001"



Adapter: "002"

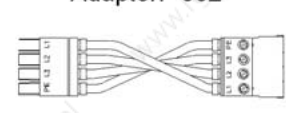

Adapter: "003"

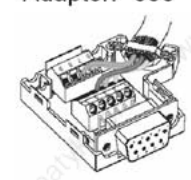

Adapter: "004"

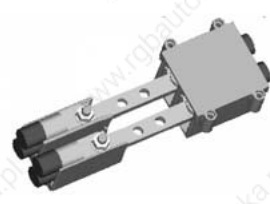

Adapter: "005"



DT000015v01\_en.FH9

Fig. 6-108: Type code HAS05.1



Applications:

HAS05-Typ	Application
HAS05.1-001-NNN-NN	is used for electrical connection between motor filter HMF01.1A-D0K2-D0045 and HCS03.1E-W0070, as well as between mains filter HNK01.1A-A075-E0050 and HCS03.1E-W0070
HAS05.1-002-NNN-NN	is used for electrical connection between mains filter HNK01.1A-A075-E0050 and HCS03.1E-W0070, if a motor filter has been mounted between HCS03.1 and mains filter

Fig. 6-109: HAS05 type

Scope of Supply:

The HAS05.1 accessories have to be ordered separately.

Accessories **HAS05.1-001-NNN-NN**

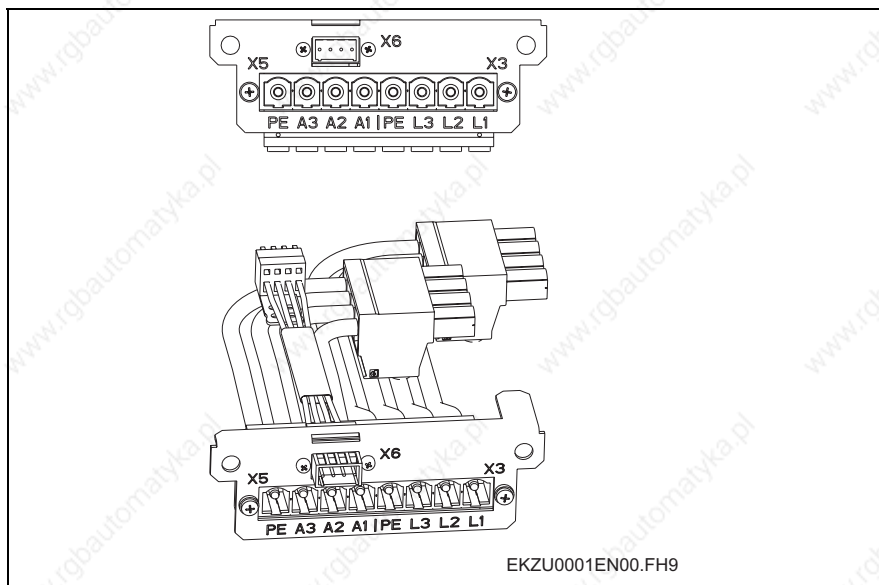

Fig. 6-110: Accessories HAS05.1-001

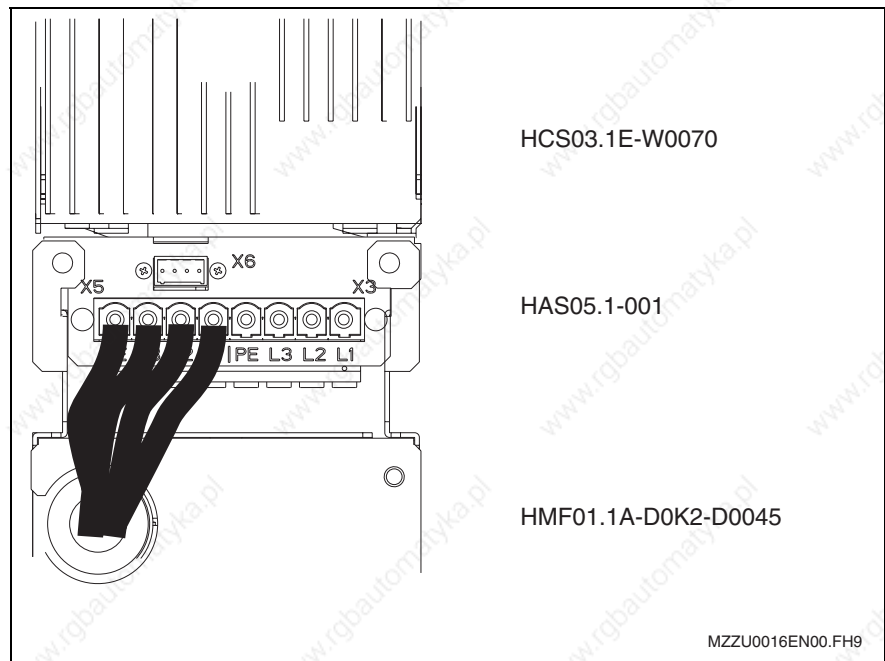

Fig. 6-111: Arrangement HCS / HAS / HMF

When mounting the motor filter HMF01.1 to HCS03.1, connection from filter to drive controller is established via connector X5 of HAS05.1-001.

When mounting the mains filter HNK01.1 to HCS03.1, connection from filter to drive controller is established via connector X3 of HAS05.1-001.

Accessories **HAS05.1-002-NNN-NN**

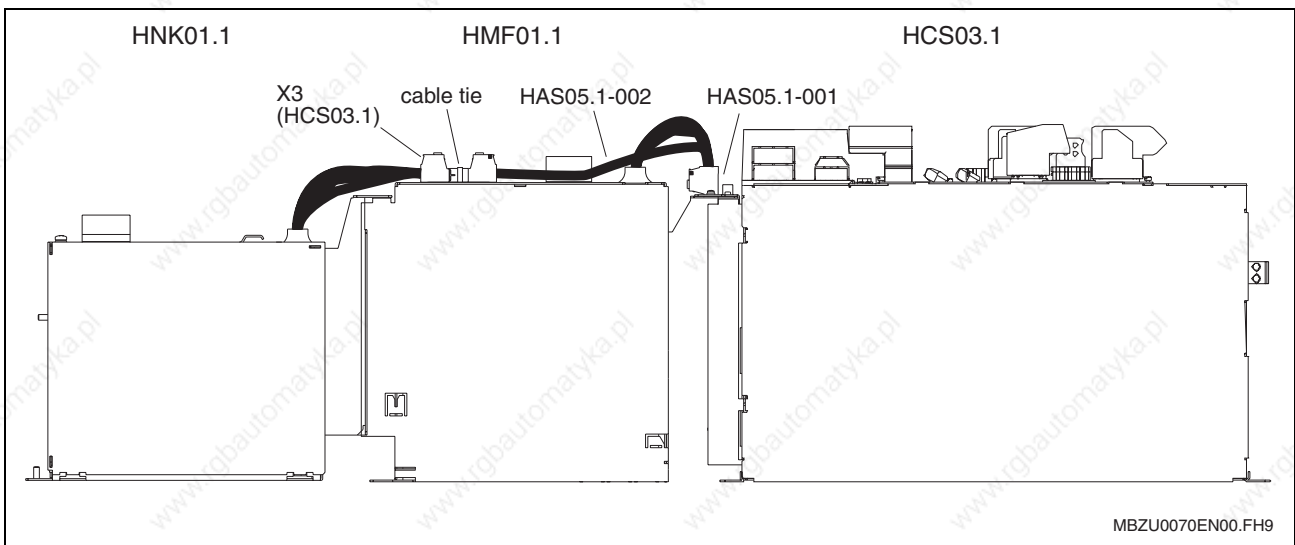

Fig. 6-112: Sample mounting HCS03.1 / HMF01.1 / HNK01.1 with accessories HAS05.1

# 7 Commissioning and Parameterization

## 7.1 Basics

### Control Panels

IndraDrive controllers are equipped with a control panel; its front consists of a display and keys located underneath it. The display shows operating states, command and error diagnoses, as well as present warnings. By means of the keys you can make settings, call information and trigger some commands.

The control panel for IndraDrive controllers can be supplied in two variants of different possibilities of display and performance:

- **standard control panel**
- **comfort control panel**

Via the serial interface of the controller it is additionally possible to connect an independent **operator terminal VCP** that can, for example, be integrated in the front of the control cabinet.

### Parameters

Communication between master and drive takes place, with a few exceptions, by means of parameters.

Parameters are used for:

- determining the configuration
- parameterizing the control loop
- triggering and controlling drive functions and commands
- transmitting command values and actual values (according to requirements, cyclically or acyclically)

All operating data are mapped to parameters!

The operating data stored in parameters can be identified by means of the IDN. They can be read and transferred, if required. The user write access to parameters depends on the properties of the respective parameter and the current communication phase. Specific parameter values (operating data) are checked for validity by the drive firmware.

### Data Storage and Parameter Handling

#### Data Memory

Several non-volatile data memories are available in an IndraDrive device:

- in the controller
- in the motor encoder (depending on motor type)

In addition, a volatile data memory (working memory) is available in the controller.

#### Condition As Supplied

Condition as supplied of the Rexroth drive components:

- The controller memory contains the drive firmware and the controller-specific parameter values.
- The motor encoder memory contains the encoder-specific and, depending on the motor type, the motor-specific parameter values.

#### Storing the Application-Specific Parameter Values

The application-specific parameter values are stored in the controller. Due to the limited number of writing cycles of non-volatile storage media,

application-specific parameter values can be stored in the working memory (volatile memory), too.

**Saving Parameter Values**

Saving application-specific parameter values is required in the following cases:

- after initial commissioning of the machine axis or the motor
- before replacing the controller for servicing (if possible)

Application-specific parameter values can be saved via:

- "IndraWorks D" commissioning tool → saving the parameter values on external data carrier
- control master → saving the parameter values on master-side data carrier
- comfort control panel

**Parameter IDN Lists**

The drive supports master-side saving of parameter values by listing parameter identification numbers (IDNs). Using these lists guarantees complete storage of the application-specific parameter values. It is also possible to determine IDN lists defined by the customer.

**Loading Parameter Values**

Loading parameter values is required in the following cases:

- initial commissioning of the motor (loading basic parameter values and motor-specific parameter values)
- serial commissioning of machine axes at series machines (loading the values saved after initial commissioning)
- reestablishing a defined original status (repeated loading of the values saved after initial commissioning)
- replacing the controller for servicing (loading the current parameter values saved before servicing)
- Possibilities of loading parameter values to the controller:
- motor encoder data memory → loading the parameter values by command or via the control panel during initial motor commissioning
- "IndraWorks D" commissioning tool → loading the parameter values from external data carrier
- control master → loading the parameter values from master-side data carrier
- comfort control panel

**Checksum of Parameter Values**

By means of checksum comparison, the control master can determine whether the values of the application-specific parameter values currently active in the drive correspond to the values saved on the master side.

## Master Communication Interfaces

The basic functions of master communication apply to each type of master communication, in the case of IndraDrive devices to SERCOS interface, field bus interface, parallel and analog interface.

### Features

All variants of master communication supported by IndraDrive have the following functional features in common:

- **address assignment**
    - communication address to be freely parameterized (via master communication, serial and control panel) via parameter **P-0-4025, Drive address of master communication**
  - **command processing**
    - drive commands to be externally activated (via master communication, serial and control panel)
  - **device control** (status machine)
    - individual status machines for master communication and device
    - According to the variant of master communication, the master communication status machine has different functionality and complexity. The communication-specific states are distinguished and mapped to the status words of the corresponding master communication (e.g. for SERCOS: S-0-0014, S-0-0135).
    - The device status machine is independent of the variant of master communication and maps the device-specific states to parameter **S-0-0424, Status parameterization level**. We always distinguish operating mode (OM) and parameter mode (PM).
  - **extended possibilities of control**
    - signal control word/signal status word (S-0-0144, S-0-0145)
    - multiplex channel
- See section "Possibilities of Control/Additional Functions" in the same chapter

---

**Note:** The status machine of the master communications is briefly outlined in this section; it will be described in detail, i.e. including the individual status transitions, in the main chapter of the respective master communication.

---

## Parameterization Mode / Operating Mode

### Communication Phases According to SERCOS Specification

**Note:** For drives of the IndraDrive range the communication phases according to SERCOS specification are valid for all kinds of master communication. The only restriction is that for field bus and parallel/analog interface only the communication phases 2, 3 and 4 are supported.

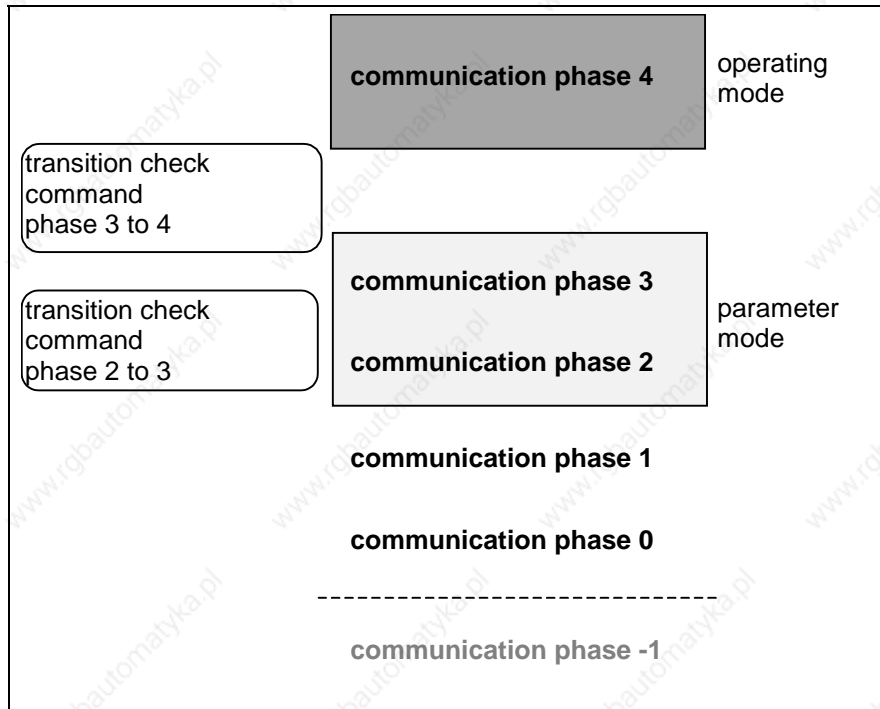

Fig. 7-1: Communication phases of the drive according to SERCOS specification

**Note:** The currently valid communication phase is contained in parameter **S-0-0014, Interface status** (bit 0...2). For field bus drives there also is the parameter **P-0-4078, Field bus: status word** (bit 0, 1) for this purpose.

The individual phases (states) have the following functions:

- **P-1:** After it is switched on, the drive goes to phase –1 and carries out a baud rate scan. As soon as the drive receives valid SERCOS telegrams from the master, it changes to phase 0.
- **P0:** The master checks the SERCOS ring by sending synchronization telegrams. During phase 0 communication between master and drive isn't possible yet.
- **P1:** When the ring is closed, the master changes to phase 1 and scans the slaves. In addition, it checks the configuration of the ring.
- **P2:** In phase 2 the complete drive parameterization can be carried out.

The following kinds of parameters **can only be changed in phase 2:**

- communication parameters (according to SERCOS)
- configuration of axis control (sampling times)

- all factory-specific settings (can only be changed via master password)
- **P3:** When changing from P2 → P3 only the parameters that can be changed in phase 2 (see above) are checked.

In phase 3 the following parameters can be changed:

- parameters for operating mode configuration
- error reaction settings
- motor configuration parameters, holding brake parameters
- encoder configuration parameters
- mechanical transmission elements (gear, feed constant)
- scaling and polarity parameters, position data format, modulo value
- configuration of analog and digital inputs/outputs
- configuration of switch on / switch off sequence of drive enable (waiting times, ...)

---

**Note:** According to SERCOS specification, the parameterization mode is divided into phases 2 and 3. In phase 3 the limit values for all scaling-dependent parameters are not yet known. When these parameters are written in phase 3, the extreme value check is only carried out during phase switch to phase 4.

---

- **P4:** In phase 4, the so-called operating mode, only the cyclic data can be changed, the configuration parameters cannot. The switch to the operating mode always causes a new initialization of all functions available in the drive.

The supported communication phases, as well as the handling of the switching between the communication phases (e.g. parameterization and operating mode) are depending on the master communication that is used. The control information preset for master communication is displayed in parameter **P-0-4086, Master communication status**.

- **SERCOS interface**

For SERCOS devices **all 5 communication phases** (as well as phase -1 → baud rate scan) are supported. According to SERCOS specification, switching takes place by setting the communication phase by the master.

- **Field bus interface**

For field bus devices **only the communication phases 2 to 4** are supported!

Switching takes place in the freely configurable operating mode (P-0-4084 = 0xFFFFE) by presetting the desired mode via bit 1 in **P-0-4077, Field bus: control word**.

Switching can also take place by executing the transition check commands (see below).

- **Parallel/analog interface**

For devices with analog or parallel interface **only the communication phases 2 to 4** are supported!

Switching always takes place when the transition check commands (see below) are executed.

After the controller is switched on it does not automatically go to the operating mode, but has to be switched to this mode by the master.

This switching of the drive controller to the operating mode is closely connected to establishing the readiness for operation.

The procedure comprises several steps and is controlled by the master by presetting communication phases –1 to 4 and starting/completing the following commands:

- **S-0-0127, C0100 Communication phase 3 transition check**
- **S-0-0128, C0200 Communication phase 4 transition check**

When the drive has reached communication phase 4 without error, the display reads "bb".

The corresponding diagnostic message is:

- **A0013 Ready for power on**

### Transition Check Commands

To switch from communication phase 2 to 3 and from 3 to 4 it is necessary to activate transition check commands in the drive:

- **S-0-0127, C0100 Communication phase 3 transition check**
- **S-0-0128, C0200 Communication phase 4 transition check**

---

**Note:** In order to get back from the operating mode to the parameterization mode, there is the command **P-0-4023, C0400 Communication phase 2 transition**.

---

#### Communication Phase 3 Transition Check

By executing the command **S-0-0127, C0100 Communication phase 3 transition check** a number of checks and parameter conversions are carried out that can possibly cause the listed command errors:

- Checking whether functional package selection was changed
  - **C0199 Functional package selection changed. Restart**  
→ drive has to be rebooted before it is possible to switch to phase 3
- Checking validity of parameters required for switching to phase 3  
If one of these parameters has never been written or the backup was carried out incorrectly, the error message "C0101" is generated. The IDNs of the faulty parameters are listed in parameter **S-0-0021, IDN list of invalid operating data for communication phase 2**. These parameters have to be set valid by writing correct values to them.
  - **C0101 Invalid parameters (-> S-0-0021)**
- Checking device configuration
  - **C0132 Invalid settings for controller cycle times**
  - **C0138 Invalid amplifier data (->S-0-0021)**
- Checking telegram configuration, especially in the case of configured telegrams  
In this case a check is run to find out whether the parameters selected for the configurable data block in the cyclic command value channel (MDT) or actual value channel (AT) may be configured and whether the allowed length of the configurable data blocks is complied with.
  - **C0104 Config. IDN for MDT not configurable**
  - **C0105 Maximum length for MDT exceeded**
  - **C0106 Config. IDNs for AT not configurable**
  - **C0107 Maximum length for AT exceeded**
- If necessary, checking timing parameters for SERCOS communication in phases 3 and 4 for validity and compliance with requirements
  - **C0108 Time slot parameter > Sercos cycle time**
  - **C0109 Position of data record in MDT (S-0-0009) even**



- C0110 Length of MDT (S-0-0010) odd
- C0111 ID9 + Record length - 1 > length MDT (S-0-0010)
- C0112 TNcyc (S-0-0001) or TScyc (S-0-0002) error
- C0113 Relation TNcyc (S-0-0001) to TScyc (S-0-0002) error
- C0114 T4 > TScyc (S-0-0002) - T4min (S-0-0005)
- C0115 T2 too small
- C0116 T3 (S-0-0008) within MDT (S-0-0089 + S-0-0010)
- C0139 T2 (S-0-0089) + length MDT (S-0-0010) > TScyc (S-0-0002)
- If necessary, checking parameters for field bus communication for validity and compliance with requirements
  - C0154 Field bus: IDN for cycl. command val. not configurable
  - C0155 Field bus: max. length for cycl. command val. exceeded
  - C0156 Field bus: IDN for cycl. actual val. not configurable
  - C0157 Field bus: length for cycl. actual values exceeded
  - C0158 Field bus: Tcyc (P-0-4076) incorrect
  - C0159 Field bus: P-0-4077 missing for cycl. command values
- Checking configuration of multiplex channel
  - C0118 Order of MDT configuration incorrect
  - C0151 IDN for command value data container not allowed
  - C0152 IDN for actual value data container not allowed
- Limit value check of communication parameters and system
  - C0102 Limit error in parameter (-> S-0-0021)
  - C0103 Parameter conversion error (->S-0-0021)
  - C0131 Switching to phase 3 impossible

#### Communication Phase 4 Transition Check

With the **S-0-0128, C0200 Communication phase 4 transition check** command the following checks and initializations are carried out that can possibly cause the listed command errors:

- Checking validity of parameters required for subsequent initializations
  - C0201 Invalid parameters (->S-0-0022)
  - C0212 Invalid control section data (->S-0-0022)
- Checking motor and encoder configuration
  - C0219 Max. travel range too large
  - C0270 Error when reading encoder data => motor encoder
  - C0271 Incorrect parameterization of motor encoder (hardware)
  - C0272 Incorr. parameteriz. of motor enc. (mechanical system)
  - C0273 Modulo value for motor encoder cannot be displayed
  - C0274 Motor encoder unknown
  - C0275 Error when reading encoder data => optional encoder
  - C0276 Incorrect parameterization of optional enc. (hardware)
  - C0277 Incorr. parameteriz. of opt. enc. (mechanical system)
  - C0278 Modulo value for optional encoder cannot be displayed
  - C0279 Optional encoder unknown
  - C0280 Maximum travel range cannot be displayed internally
  - C0284 Invalid motor data in encoder memory (->S-0-0022)

- **C0285 Type of construction of motor P-0-4014 incorrect**
- **C0286 Several motor encoders connected**
- **C0287 Error during initialization of motor data (->S-0-0022)**
- **C0288 Rotary scaling not allowed**
- **C0289 Error at init. of synchr. motor with reluctance torque**
- **C0290 Error when reading encoder data => measuring encoder**
- **C0291 Incorr. parameterization of measuring enc. (hardware)**
- **C0292 Measuring encoder unknown**
- **C0293 Modulo value for measuring encoder cannot be displayed**
- **C0294 Incorrect measuring encoder configuration**
- Checking modulo range
  - **C0244 Act. modulo value cycle greater than max. travel range**
- Checks during encoder initialization
  - **C0220 Error when initializing position of encoder 1**
  - **C0221 Initialization velocity encoder 1 too high**
  - **C0224 Error when initializing position of encoder 2**
  - **C0225 Initialization velocity encoder 2 too high**
  - **C0227 Error when initializing position of measuring encoder**
  - **C0228 Initialization velocity measuring encoder too high**
- Initializing optional additional functions (digital I/Os)
  - **C0243 Brake check function not possible**
  - **C0250 Probe inputs incorrectly configured**
  - **C0260 Incremental enc. emulator resol. cannot be displayed**
- Initializing integrated safety technology
  - **C0254 Configuration error PROFIsafe**
  - **C0255 Safety command for system init. incorrect**
  - **C0257 No encoder assigned to slot 1**
- Limit value check
  - **C0202 Parameter limit error (->S-0-0022)**
  - **C0203 Parameter calculation error (->S-0-0022)**
- General system checks
  - **C0245 Operating mode configuration (->S-0-0022) not allowed**
- Initializing fine interpolator
  - **C0258 Error in relation TNcyc (S-0-0001) to fine interpol.**
- Initializing digital inputs/outputs
  - **C0246 Trav. range lim. switch not ass. to dig. input**
  - **C0247 Dig. output already assigned to other axis**
  - **C0248 Dig. input assigned differently to axes**
  - **C0249 Dig. I/Os: bit number too large**
- Checking interface configuration
  - **C0242 Multiple configuration of a parameter (->S-0-0022)**
- Checking master communication
  - **C0251 Error during synchronization to master communication**

## Default Settings in the Motor Encoder Data Memory ("Load Defaults Procedure")

### Loading Basis Parameter

The following Rexroth housing motors are equipped with an encoder data memory:

- MHD, MKE, MKD
- MSK, MSH, MAD, MAF, MAL

---

**Note:** The Bosch motor with the type designation "SF..." that can be operated with IndraDrive controllers is equipped with an encoder data memory, too. As regards commissioning and parameters, SF motors have the same behavior as Rexroth housing motors with encoder data memory!

---

### Notes on Commissioning

#### Initial Commissioning

In the case of Rexroth housing motors with encoder data memory, the values for the motor parameters stored in the encoder, the measuring system parameters and, where required, the motor holding brake parameters are automatically loaded to the controller when the drive is switched on.

At the initial commissioning of a drive the **F2008 RL The motor type has changed**. error message will appear. This message only means that this motor has not yet been connected to the controller.

By clearing this error message (reset via control panel or S-0-0099, C0500 Reset class 1 diagnostics) **S-0-0262, C07\_x Load defaults procedure command** is automatically started. Default control loop parameter values for this motor are thereby loaded.

---

**Note:** Depending on the setting in **P-0-4090, Index for C07 Load defaults procedure**, the following parameter values are loaded with the "load defaults procedure" command (S-0-0262):

- default control loop parameter values (default setting)
  - basic parameter values (default parameter set) of the firmware.
- 

In the case of motors with integrated holding brake, the type of motor holding brake and the activation of the brake control is automatically set in **P-0-0525, Holding brake control word**.

In the case of motors with several cooling type variants (MHD, MKD), the load data can be referred to the cooling type realized by entering the corresponding value in **P-0-0640, Cooling type**.

#### Recommissioning

When the machine is repaired the motor can be replaced by a motor of the same type without any problem. The adjustment to the controller does not need to be repeated. In the case of an absolute motor encoder, it is only necessary to make an adjustment to the machine axis by establishing the position data reference.

If the motor type connected to the controller has changed, the controller signals this with **F2008 RL The motor type has changed**. and requests the default control loop parameter values and the motor type parameter to be loaded. In the case of a desired motor change, initial commissioning of the new axis motor is necessary. Otherwise there is an assembly error that has to be corrected!

**Diagnostic Messages**

- While the default control loop parameter values and the motor type parameter is loaded the controller signals:  
**C07\_0 Load defaults procedure com. (load controller param.)**
- If the parameter values in the encoder data memory cannot be read:  
**C0706 Error when reading the controller parameters**
- If the motor type connected to the controller has changed:  
**F2008 RL The motor type has changed.**
- If an invalid value for the commutation offset is contained in the encoder memory, the controller signals:  
**F2104 Commutation offset invalid**

**Load Defaults Procedure****S-0-0262, C07\_x Load defaults procedure command**

For all Rexroth motors of the series with motor encoder data memory (e.g. MHD, MKD, MKE, MSK and possibly MAD and MAF), the basic settings for the controllers are stored and can be loaded to the drive by executing the "load defaults procedure" command (S-0-0262).

There are two ways to activate the **S-0-0262, C07\_x Load defaults procedure command** parameter:

- Automatically when running up the drive by recognizing that the motor type (cf. parameter S-0-0141) has changed. The display then reads "RL" and the "load defaults procedure" command is internally started by pressing the "Esc" button on the control panel, unless this was deactivated in **P-0-0556, Control word of axis controller**.
- Starting the command by writing "11b" to parameter S-0-0262.

See also "Loading, Storing and Saving Parameters" in chapter "Handling, Diagnostic and Service Functions"

---

**Note:** In order to start the "load defaults procedure" command the value "0" (default setting) must have been set in parameter **P-0-4090, Index for C07 Load defaults procedure**.

---

During the load defaults procedure, the following control loop parameters are set to their default values optimized for the respective motor:

- **S-0-0100, Velocity loop proportional gain**
- **S-0-0101, Velocity loop integral action time**
- **S-0-0104, Position loop Kv-factor**
- **S-0-0106, Current loop proportional gain 1**
- **S-0-0107, Current loop integral action time 1**
- **P-0-0004, Velocity loop smoothing time constant**

---

**Note:** The default settings for the current loop (cf. S-0-0106 and S-0-0107) are automatically adjusted to the currently parameterized PWM frequency (cf. P-0-0001) and performance setting (cf. P-0-0556)!

---

In addition, the following control loop parameters are set to their firmware-side default values although there haven't been any default values stored for them in the motor data memory:

- **S-0-0348, Acceleration feedforward gain**
- **P-0-1125, Velocity control loop: average value filter clock**

---

**Note:** In the majority of cases, the controller settings stored in the motor encoder data memory provide a useful and reliable control loop setting. In exceptional cases, however, it may be necessary to make the settings with regard to the specific application.

---

## 7.2 Parameterization

### Control Panels

#### Standard Control Panel

Can be used with control sections CSB01, CSH01, CDB01.



Fig. 7-2: Standard control panel

#### Possibilities of Display of Standard Control Panel

The standard control panel allows the following displays:

- status of the master communication
- operating status
- activated commands and command diagnoses
- warnings and error diagnoses
- extended displays such as contents of error memories, diagnostic message memory, operating hours counter of control section, operating hours counter of power section, type designation of firmware active in the device, safety technology code (if safety technology option available)

#### Possible Settings with Standard Control Panel

The following settings can be made with the standard control panel:

- set the drive address (drive number in the bus system of the master communication)
- set the length of the fiber optic cable
- activate the master communication mode "Easy Startup"

#### Command Activation with Standard Control Panel

The following commands can be activated with the standard control panel:

- activate **S-0-0262, C07\_x Load defaults procedure command** (load controller parameters or basic parameters)
- activate other commands, such as:
  - **C2200 Backup working memory procedure command**
  - **C2300 Load working memory procedure command**
  - **C2500 Copy IDN from optional memory to internal memory**
  - **C2600 Copy IDN from internal memory to optional memory**

## Comfort Control Panel



Fig. 7-3: Comfort control panel

**Note:** The comfort control panel

- can be used with control sections **CSB01.1N-FC**
- requires firmware FWA-INDRV\*-MPB-04V12 at least
- only supports **voltage controlled operation** (V/f control)
- must have been **plugged in when** the drive controller is **switched on** so that it can be recognized
- is **suited for hot plug**, i.e. you may disconnect it when the drive controller has been switched on

Compared to the standard control panel, the comfort control panel, due to the fact that it can be programmed, provides additional settings, as well as additional display and command functions.

### Possibilities of Display of Comfort Control Panel

Additional possibilities of display of the comfort control panel (compared to the standard control panel), for example:

- cyclic parameter display
- measured value of motor temperature sensor
- message threshold or shutdown threshold for motor temperature
- active switching frequency (PWM)

**Note:** To use this function you need a comfort control panel of version VCP01.2BWA-TS-NN-FW (see type plate of comfort control panel).

### Possible Settings with Comfort Control Panel

Additional possibilities of setting of the comfort control panel (compared to the standard control panel), for example:

- language selection
- set/change single parameters
- input of motor data acc. to type plate data for asynchronous third-party motors

### Command Activation with Comfort Control Panel

Activation of further commands with the comfort control panel (compared to the standard control panel), for example:

- **C3200 Command Calculate motor data**

The comfort control panel in particular supports the commissioning of asynchronous third-party motors – another commissioning tool is **not** required for this purpose. The required steps are given by the display, the corresponding input is made by means of the keys of the control panel.

#### Editing Mode

The editing mode is the status in which you can enter or change values by pressing the key **Prog+** or **Mon** at the control panel. The corresponding field of the value then is highlighted in black on the display. To have the value applied by the drive press the **Enter** key. If you do not want to apply changed values, press the **Esc** key. By doing this you exit the editing mode. The corresponding field then no longer is highlighted in black.

#### Keys









Key	Function
	<ul style="list-style-type: none"> <li>return to previous menu item (without applying possibly changed values)</li> <li>exit editing mode (without applying possibly changed values)</li> <li>reset error</li> </ul>
	<ul style="list-style-type: none"> <li>Editing mode: reduce value</li> <li>Motor potentiometer: reduce speed</li> <li>go to monitor mode</li> </ul>
	<ul style="list-style-type: none"> <li>Editing mode: increase value</li> <li>Motor potentiometer: increase speed</li> </ul>
	Editing mode: apply displayed value
	arrow key (e.g. navigation up)
	arrow key (e.g. navigation down)
	arrow key (e.g. navigation to previous display mask, cursor to the left)
	arrow key (e.g. navigation to subsequent display mask, cursor to the right)

Fig. 7-4: Keys



**Display Mask** The figure below illustrates a typical display mask of the comfort control panel.

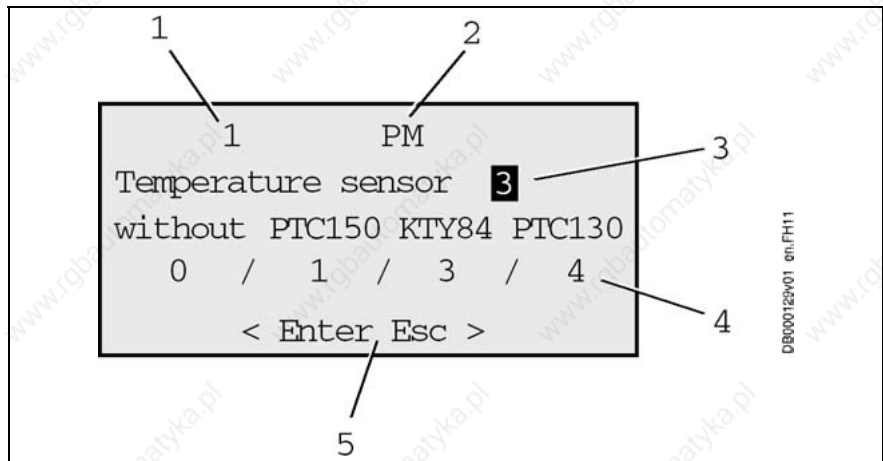

- 1: drive address of master communication
- 2: display text of diagnostic message (PM: Parameterization mode)
- 3: value which can be changed (changeable values are highlighted in black [editing mode]; value can be changed with Prog+ or ~Mon keys; changed value is applied with Enter key; with Esc key you can exit the editing mode without applying the changed value)
- 4: parameter with its possible values (in this example, 0, 1, 3 or 4 can be selected as value for parameter "P-0-0512, Temperature sensor")
- 5: displays the keys with which an action can be carried out
  - <: go to previous display mask
  - Enter: apply changed value
  - Esc: exit the editing mode without applying the changed value
  - >: go to next display mask

Fig. 7-5: Display mask

## Menu Structure

The diagram below shows the complete menu structure of the control panel. The individual modes (monitor, operating and parameter modes) are described in the next sections.

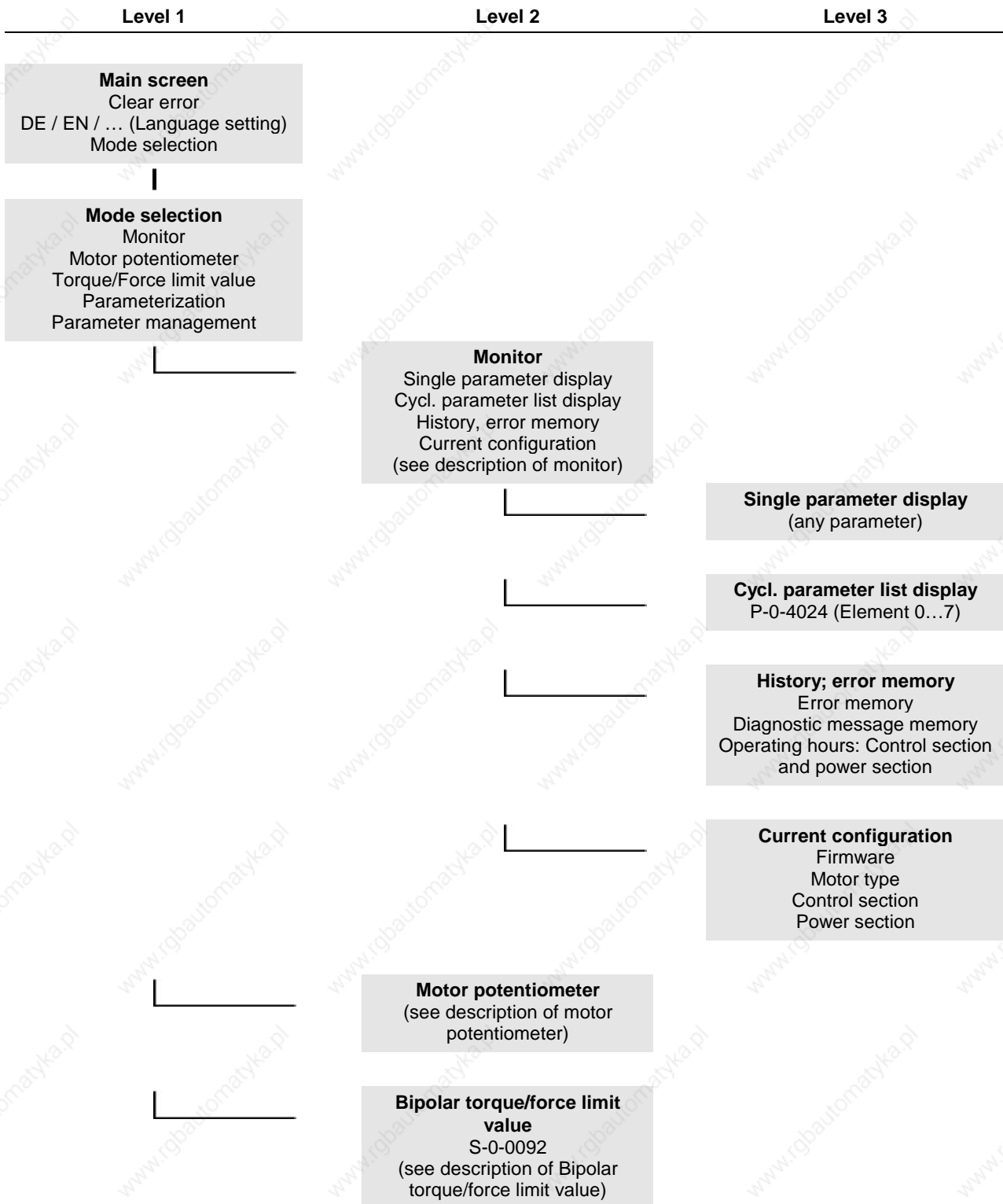

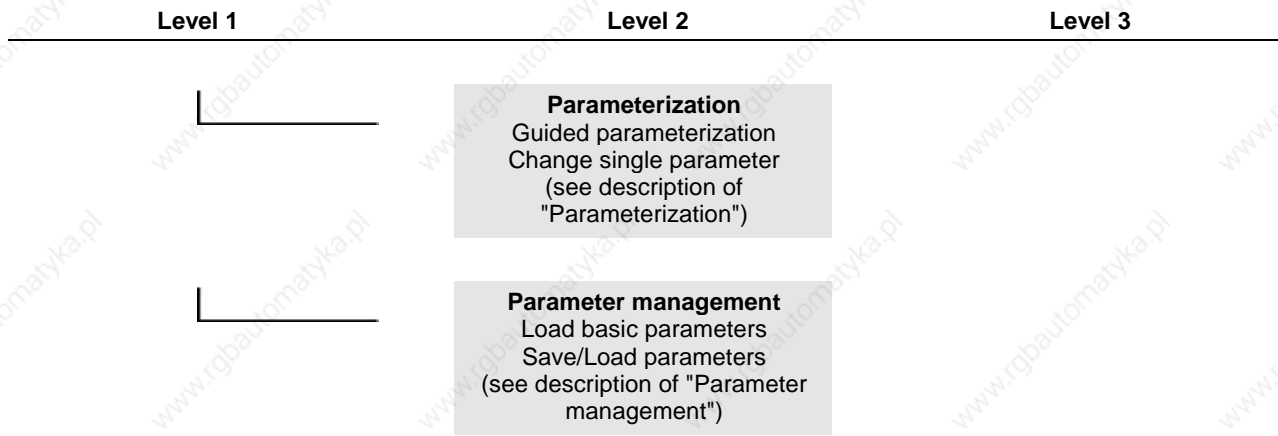

Fig. 7-6: Menu structure

**Start Screen** When you switch the drive controller on, the following start screen appears after a boot sequence with various displays:

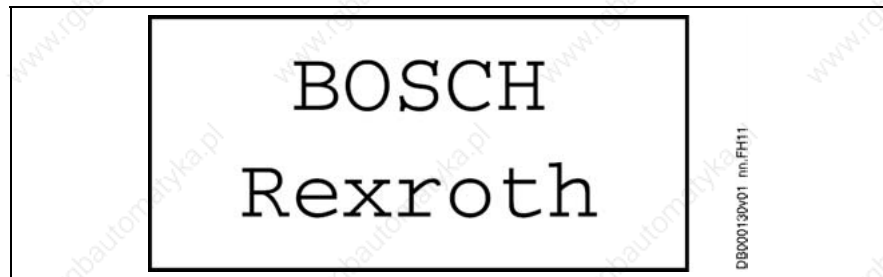

Fig. 7-7: Start screen

**Main Screen** After the start screen, the control panel automatically displays the main screen:

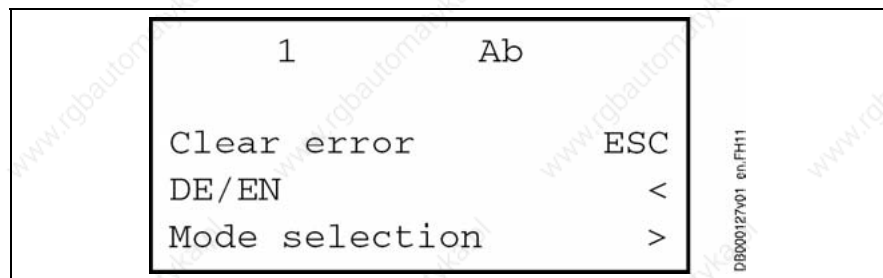

Fig. 7-8: Main screen

**On the main screen you can:**

- With **Clear error**, clear errors which are present:  
First remove cause of error.  
Then press **Esc** key.
- Set the language in which text is displayed. Main screen only shows languages which are available (e.g. DE: German; EN: English; FR: French; IT: Italian; SP: Spanish).

**DE/EN/... (Language setting):**

Press key ◀:

Screen for setting the language is displayed.

Press **Prog**<sup>+</sup> or **Mon** key to set desired language:

- 0: German
- 1: English
- 2: French
- 3: Italian
- 4: Spanish

Press **Enter** key.

- Go to **Mode selection**:  
Press key ►.  
Selection list is displayed:

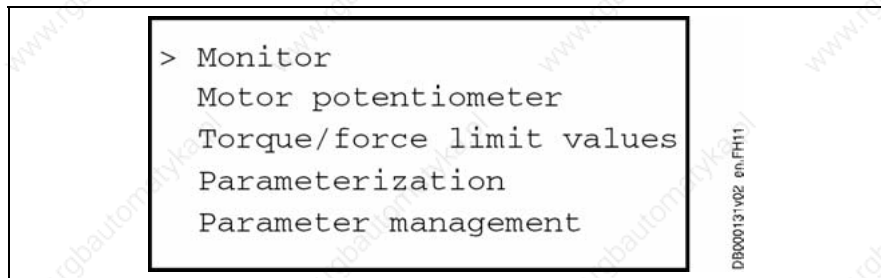

Fig. 7-9: Mode selection

With key ▲ or ▼ select desired menu item. Symbol ">" in left-most position marks selected menu item.  
Then press key ►.

- Go directly to **Monitor**:  
Press **Mon** key.

## Monitor

### Go to Monitor

- Starting point: main screen;  
By pressing key ◀ several times you get to main screen. By means of **Esc** key, you might possibly have to exit editing mode before.
- By means of **Mon** key, go to monitor.  
Selection list appears.

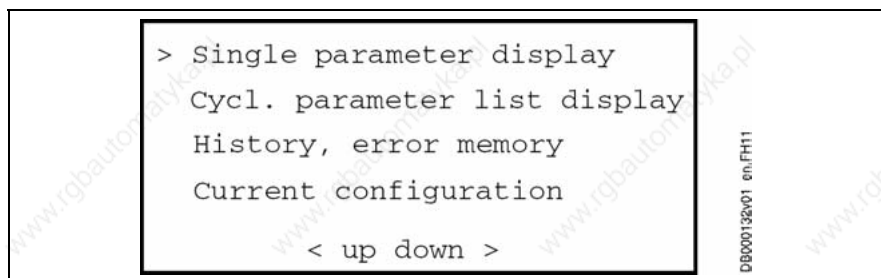

Fig. 7-10: Monitor mode

- With key ▲ or ▼ select desired menu item. Symbol ">" in left-most position marks selected menu item.  
Then press key ►.

**Single Parameter Display** With **Single parameter display** it is possible to display the value of any parameter.

How to select the parameter:

- Select **Single parameter display**.
- Press key ► .  
Last selected parameter is displayed.
- With keys **Prog<sup>+</sup>**, **Mon**, **Enter**, ◀, ▶, enter desired parameter (see also example below):  
**Prog<sup>+</sup>**, **Mon**: change setting  
**Enter**, ◀, ▶: move cursor to the left or to the right

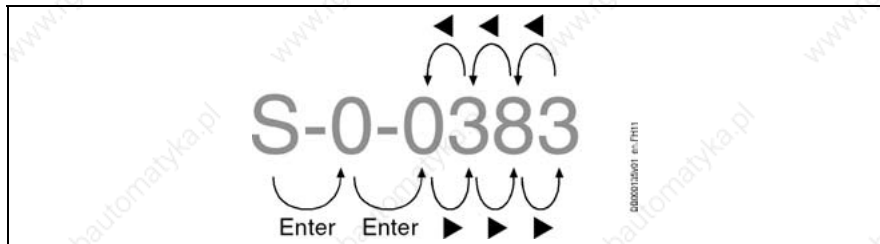

Fig. 7-11: Enter parameter

- Press **Enter** key.
- Press **Esc** key.
- Press key ► .  
Value of parameter is displayed.
- Press **Esc** key.
- Press key ▼ .  
Name and unit of parameter are displayed.
- Press key ◀ to go to previous display.

**Example:**

Last parameter displayed was S-0-0383.  
Parameter P-0-1222 is to be displayed.

- S → key **Prog<sup>+</sup>** → P → key **Enter**
- 0 → key **Enter**
- 0 → key **Prog<sup>+</sup>** → 1 → key ►
- 3 → key **Mon** → 2 → key ►
- 8 → key **Mon** → 7 ... → key **Mon** → 2 → key ►
- 3 → key **Mon** → 2 → key ►
- Press **Enter** key.
- Press **Esc** key.
- Press ► key.  
Value of parameter P-0-1222 is displayed.
- Press **Esc** key.
- Press ▼ key.  
Name and unit of parameter are displayed.

**Cyclic Parameter List Display**

Up to 8 arbitrary parameters can be displayed. The parameters can be displayed successively. Parameter P-0-4024 contains the IDNs of the parameters which can be selected for cyclic parameter display.

Presetting of list in P-0-4024:

List element	Listed IDN	
0	S-0-0040	Velocity feedback value
1	S-0-0084	Torque/force feedback value
2	P-0-0043	Torque-generating current, actual value
3	S-0-0382	DC bus power
4	S-0-0000	dummy ID
5	S-0-0000	dummy ID
6	S-0-0000	dummy ID
7	S-0-0000	dummy ID

Fig. 7-12: Presetting of list in P-0-4024

The "dummy" S-0-0000 will be ignored during configuration, i.e. only entries with valid IDNs are displayed (in this case: entries in list elements 0...3).

- From each display you can go to setting of list parameter P-0-4024 by pressing **▲** key.
- Select IDN in table by pressing **▲** or **▼** key.
- Modify IDN.
- Press **Enter** key.
- Press **Esc** key.
- Press **▶** key to restart cyclic parameter display.  
At first, list entries are checked. Then first parameter of list is displayed. Top right you see number of list element displayed.

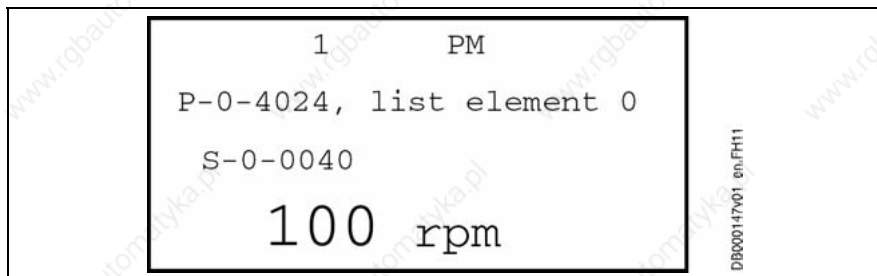

Fig. 7-13: Example of the first list element displayed

- Press **▶** key to go to next list element.
- Press **◀** key to go to previous list element.
- Press **Esc** key to leave the Cyclic Parameter List Display

- History, Error Memory**
- **Error memory** (P-0-0192) with indication of time during which error is present (P-0-0193)
  - Press ► key.
  - **Diagnostic message memory** (S-0-0375) with indication of time during which diagnostic message is present (P-0-0105)
  - Press ► key.
  - **Operating hours:**  
Control section (P-0-0190)  
Power section (P-0-0191)  
The operating hours are displayed as seconds.

- Current Configuration** Current configuration of the drive controller:
- **Firmware**  
display of firmware version (S-0-0030)
  - **Motor type**  
type designation of motor (S-0-0141)
  - Press ► key.
  - **Control section**  
type designation of control section (P-0-1520)
  - **Power section**  
type designation of power section (S-0-0140)

## Motor Potentiometer

**Requirements** To use the motor potentiometer you must have selected and parameterized "Motor potentiometer" as velocity command value (see description of "Guided Parameterization").

- Motor Potentiometer Operation**
- Starting point: main screen  
By pressing key ◀ several times you get to main screen. By means of **Esc** key, you might possibly have to exit editing mode before.
  - Press key ►.  
Mode selection is displayed.
  - Select **Motor potentiometer**.
  - Press key ►.  
Motor potentiometer display appears:

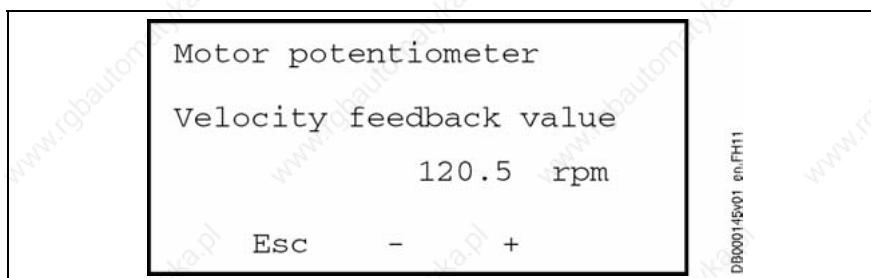

Fig. 7-14: Motor potentiometer

- **Reduce** velocity of motor:  
Press **Mon** key and keep it pressed.
- **Increase** velocity of motor:  
Press **Prog**<sup>+</sup> key and keep it pressed.
- Exit motor potentiometer:  
Press **Esc** key.



## Bipolar Torque/Force Limit Value

- Starting point: main screen  
By pressing key ◀ several times you get to main screen. By means of **Esc** key, you might possibly have to exit editing mode before.
- Press ▶ key.  
Mode selection is displayed.
- Select **Bipol. torque/force limit val.**
- Press ▶ key.  
Following display appears. Enter desired value for "bipolar torque/force limit value" (parameter S-0-0092).

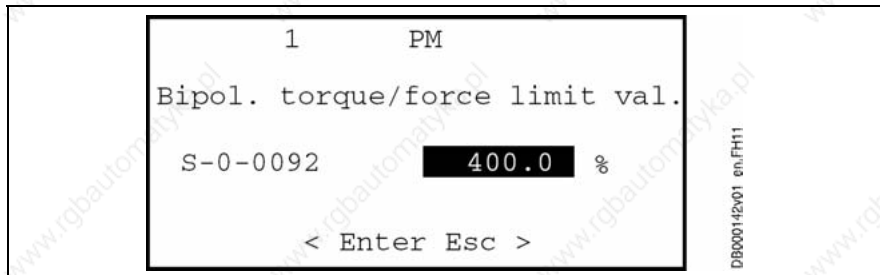

Data field in which you can make inputs is highlighted in black.

Fig. 7-15: Bipolar torque/force limit value (S-0-0092)

- Data field in which you can make inputs is highlighted in black.
- Enter desired value:  
◀, ▶: move cursor to the left or to the right  
**Prog**†, **Mon**: change setting
- Press **Enter** key to confirm your setting.
- Press **Esc** to leave editing mode.

### S-0-0092

By this parameter it is possible to limit the torque/force command value to allowed maximum values in order to protect the mechanical components.

The parameter acts in a bipolar way, i.e. positive and negative command values are limited to the entered value. The limitation acts on the sum of all torque command values, i.e. on the sum of the command value components of the velocity controller output and the command value components from acceleration-dependent feedforwards ("S-0-0348, Acceleration feedforward gain"; "P-0-1126, Velocity control loop: acceleration feedforward"). The unit of S-0-0092 depends on the scaling that has been set.

**Note:** The effective limit value is displayed in P-0-0049, Effective torque/force command value. This value can be limited with regard to S-0-0092, due to a lower value in "P-0-0109, Torque/force peak limit" or due to a current limit by the respective work load of amplifier or motor.

If in stationary operation (constant speed) a lower torque than in the case of acceleration processes is to be made available to the drive, this can be achieved by appropriate values of "S-0-0082, Torque/force limit value positive" and "S-0-0083, Torque/force limit value negative" in conjunction with acceleration feedforward (S-0-0348 or P-0-1126).

The bipolar torque/force limit value also acts on "C1300 Positive stop drive procedure command", the value of S-0-0092 is a criterion for the acknowledgment of C1300.

## Parameterization

- Go to main screen.  
By pressing key ◀ several times you get to main screen. By means of **Esc** key, you might possibly have to exit editing mode before.
- Press key ▶.  
Mode selection is displayed.
- Select **Parameterization**
- Press key ▶.  
Parameter mode is automatically displayed. Following display appears:

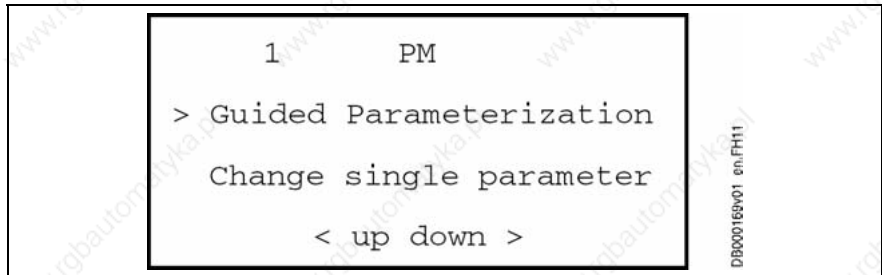

Fig. 7-16: Display "Parameterization"

When drive controller was in status AF (drive enable), following display appears:

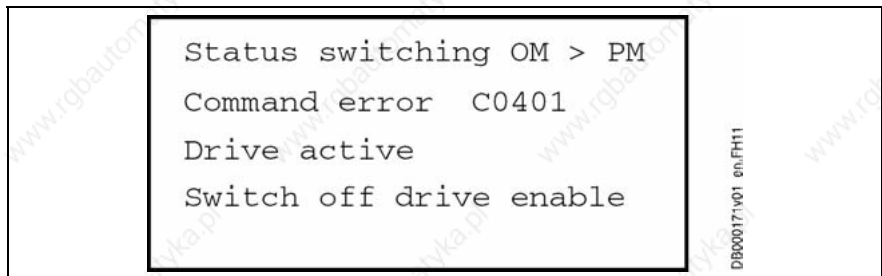
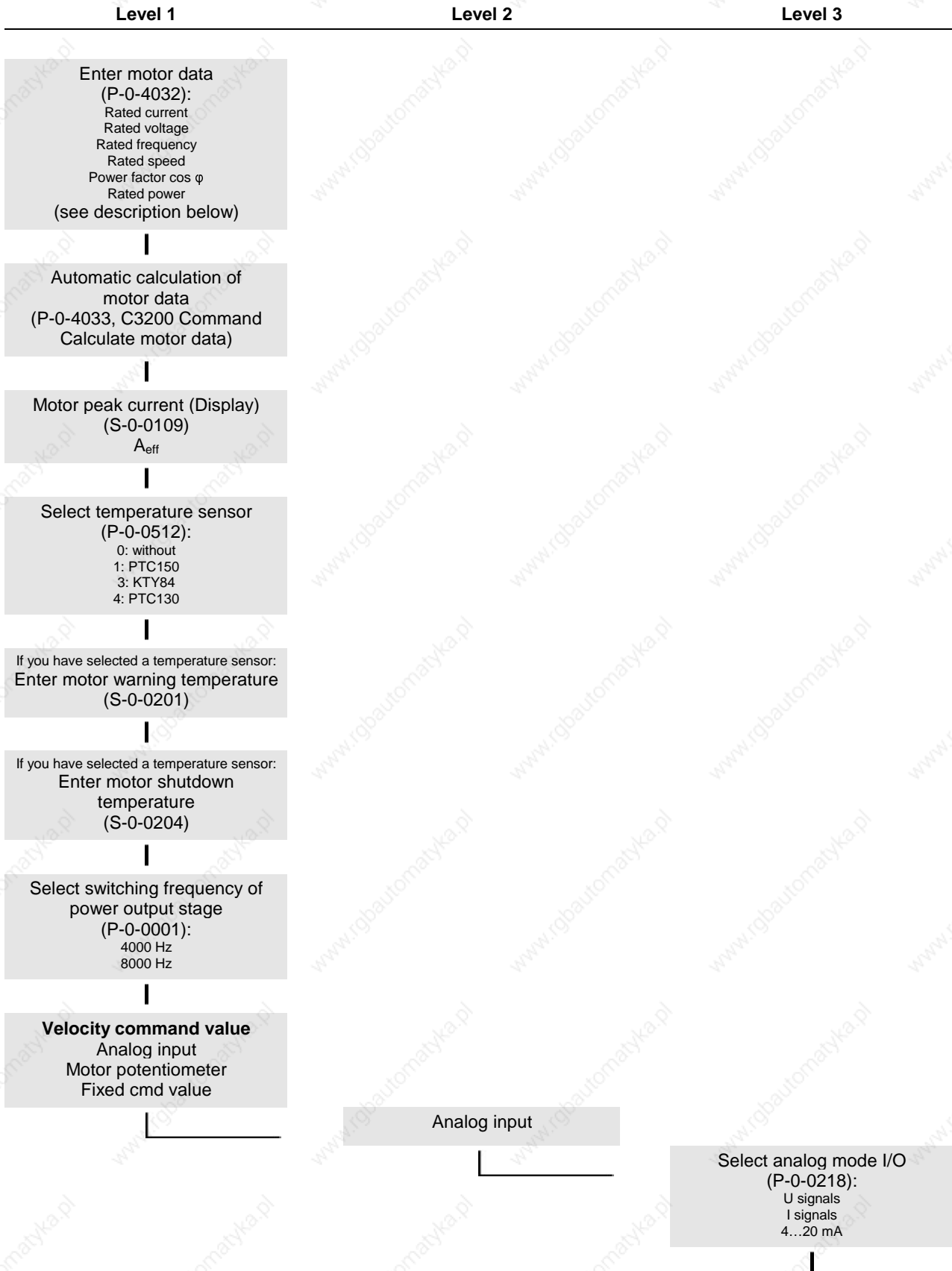

Fig. 7-17: Error message when switching operating mode/parameter mode

Switch off drive enable and repeat procedure.

**Guided Parameterization**

- Select **Guided Parameterization**.
- Press ► key.  
"Motor data" display appears:



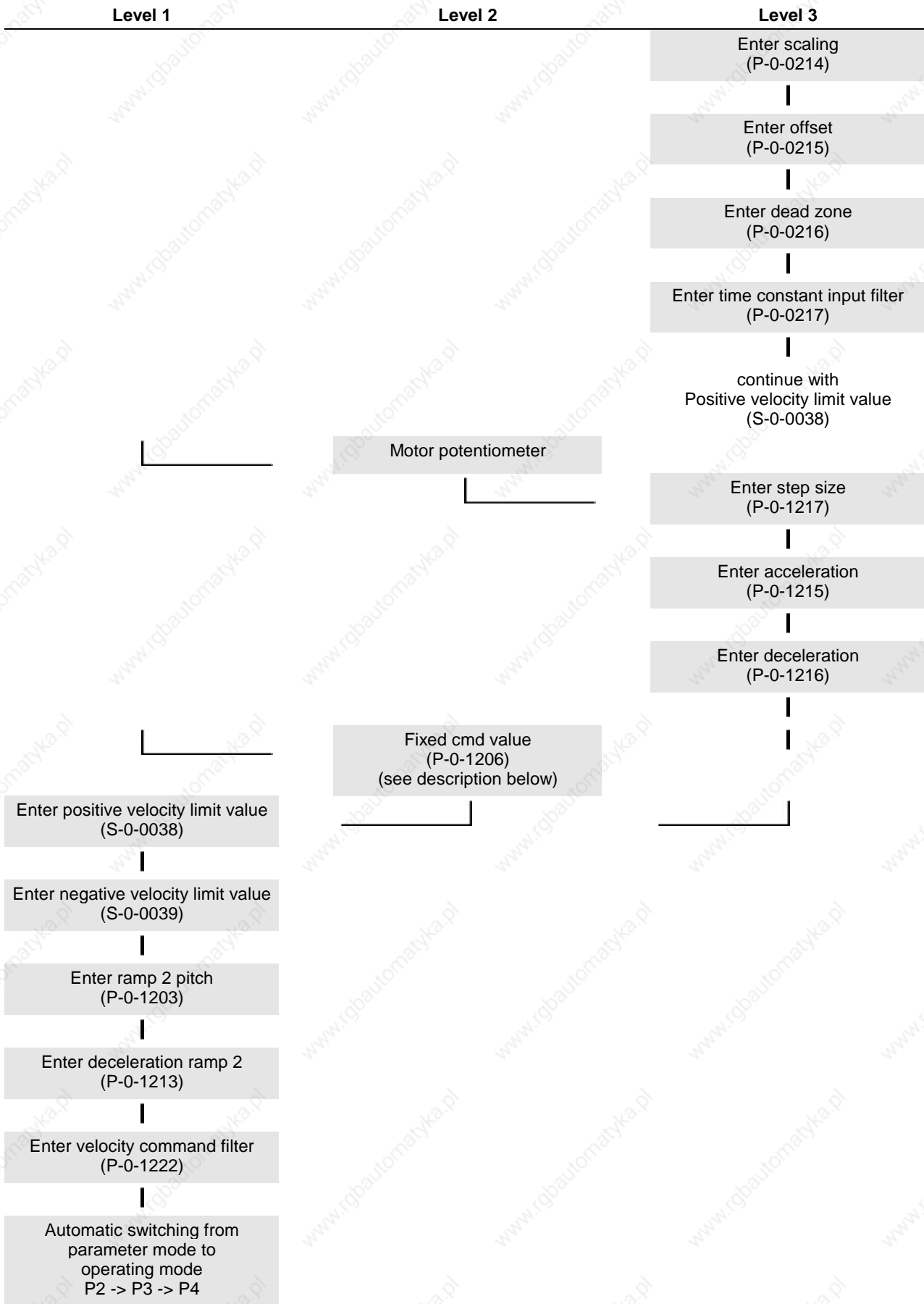
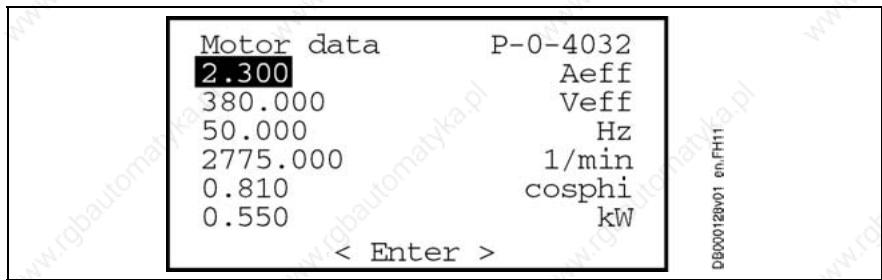

Fig. 7-18: Settings (parameterizing the drive controller)

**Enter Motor Data:**

At the beginning of parameterization you must enter the motor data (see type plate of motor).



Data field in which you can make inputs is highlighted in black.

Fig. 7-19: Enter motor data (example)

List element	Characteristic value of motor	Unit	Definition
0	rated current	A <sub>eff</sub>	rms value of the electric current in the motor feed wire (motor phase) at rated load
1	rated voltage	V <sub>eff</sub>	rms value of the phase-to-phase voltage between the motor terminal pins at rated load
2	rated frequency	Hz	frequency of the feeding, sinusoidal electric voltage
3	rated speed	1/min	speed of motor output shaft at rated load
4	power factor cos φ	1	power factor at rated load
5	rated power	kW	mechanical power that can be continuously delivered at rated load

Fig. 7-20: List elements P-0-4032

- Data field in which you can make inputs is highlighted in black.
- With key ▲ or ▼ you can select a specific data field.
- With keys ◀, ▶, Prog+, Mon enter desired value:  
◀, ▶: move cursor to the left or to the right  
Prog+, Mon: change setting
- With Enter key confirm entered value.  
Next data field is automatically activated.
- When you have made all inputs:  
Press Esc key.

**Fixed Command Value (P-0-1206):**

After selecting **Fixed cmd value** the following display appears (example):

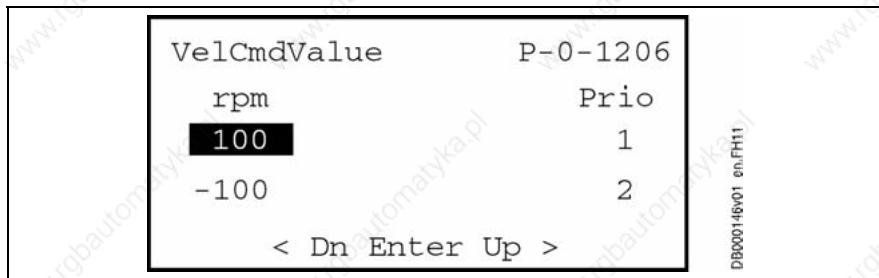

Data field in which you can make inputs is highlighted in black (editing mode).

Fig. 7-21: Fixed command value (example)

- To display all fixed command values:
  - In editing mode: Press **▲** or **▼** key
  - Else: Press **Prog+** or **Mon** key
- To modify fixed command values (in editing mode only):
  - Press **Prog+** or **Mon** key.
  - Press **Enter** key to confirm your setting.
  - Press **Esc** key to leave editing mode.

**P-0-1206, Memory of velocity command values:**

Function of the parameter:

Five velocity command values are stored in this list parameter. In contrast to S-0-0036 this parameter cannot be cyclically written. It is used as a fixed command value memory the individual values of which can be selected via the control word P-0-1200 (switch function). The range of values and unit of the parameter elements in P-0-1206 correspond to those of the velocity command value S-0-0036.

See also Functional Description "Operating Modes - Velocity Control"

Parameter structure:

For selecting the command values there is the following assignment:

P-0-1206	Selection by P-0-1200	Priority
element 1	bit 0 = 1	1
element 2	bit 1 = 1	2
element 3	bit 2 = 1	3
element 4	bit 3 = 1	4
element 5	bit 4 = 1	5

If more than one bit has been set, the priority indicated in the right column applies (1 = highest priority).

**Change Single Parameter**

- Go to main screen.  
By pressing key ◀ several times you get to main screen. By means of **Esc** key, you might possibly have to exit editing mode before.
- Press key ▶.  
Mode selection is displayed.
- Select **Parameterization**.
- Press key ▶.  
Parameter mode is automatically displayed. Following display appears:

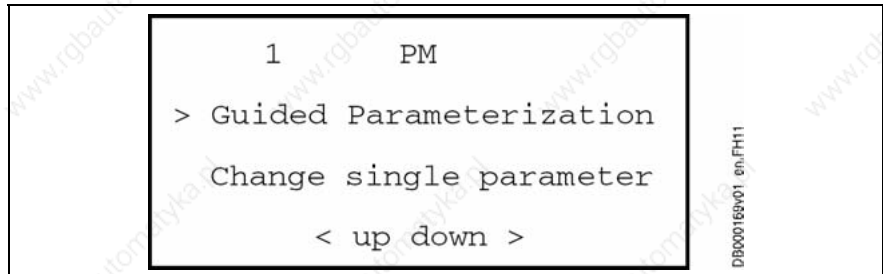

Fig. 7-22: Parameterization

When drive controller was in status AF (drive enable), following display appears:

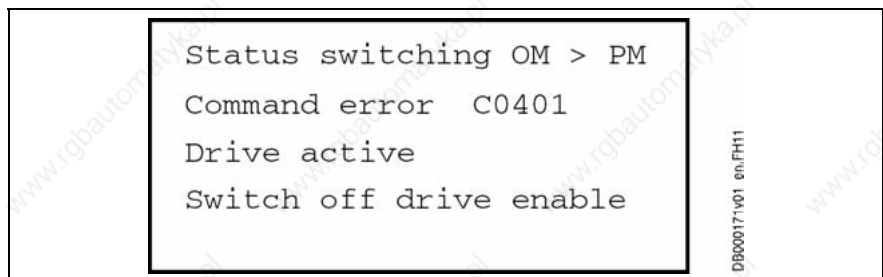

Fig. 7-23: Error message when switching operating mode/parameter mode

Switch off drive enable and repeat procedure.

- Select **Change single parameter**
- Press **▶** key.  
The following display appears:

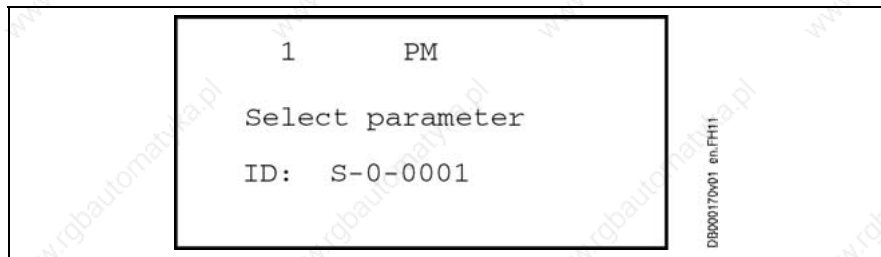

Fig. 7-24: Select parameter

- With keys **Prog<sup>+</sup>**, **Mon**, **Enter**, **◀**, **▶**, enter desired parameter (see also example below):  
**Prog<sup>+</sup>**, **Mon**: change setting  
**Enter**, **◀**, **▶**: move cursor to the left or to the right

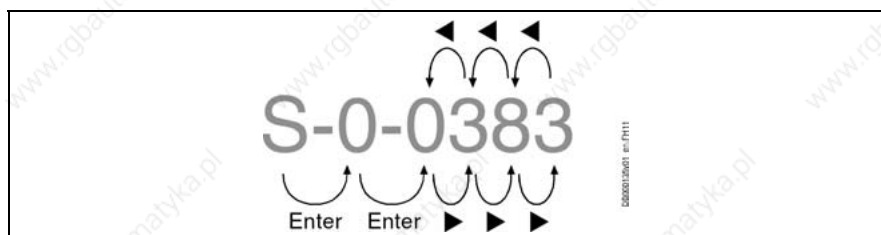

Fig. 7-25: Enter parameter

- After desired parameter has been entered:  
Press **Enter** key.
- Press **Esc** key.
- Press key **▶**.  
Value of parameter is displayed.
- Press **Esc** key.

To display name and unit of parameter:

- Press key **▼**.  
Name and unit of parameter are displayed.
- Press key **◀** to go to previous display.

#### Example:

Last parameter displayed was S-0-0383.  
Parameter P-0-1222 is to be displayed.

- S → key **Prog<sup>+</sup>** → P → key **Enter**
- 0 → key **Enter**
- 0 → key **Prog<sup>+</sup>** → 1 → key **▶**
- 3 → key **Mon** → 2 → key **▶**
- 8 → key **Mon** → 7 ... → key **Mon** → 2 → key **▶**
- 3 → key **Mon** → 2 → key **▶**
- Press **Enter** key.
- Press **Esc** key.
- Press **▶** key.  
Value of parameter P-0-1222 is displayed.
- Press **Esc** key.



- Press ▼ key.  
Name and unit of parameter are displayed.

### Parameter Management

- Go to main screen.  
By pressing key ◀ several times you get to main screen. By means of **Esc** key, you might possibly have to exit editing mode before.
- Press key ▶ .  
Mode selection is displayed.
- Select **Parameter management**
- Press key ▶ .  
Parameter mode is automatically displayed. Following display appears:

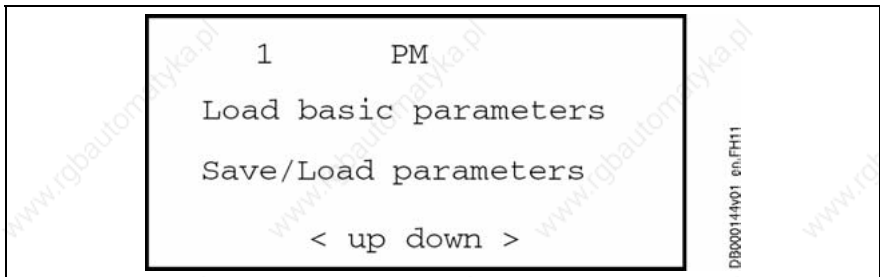

PM: parameter mode  
Fig. 7-26: Display "Load basic parameters"

When drive controller was in status AF (drive enable), following display appears:

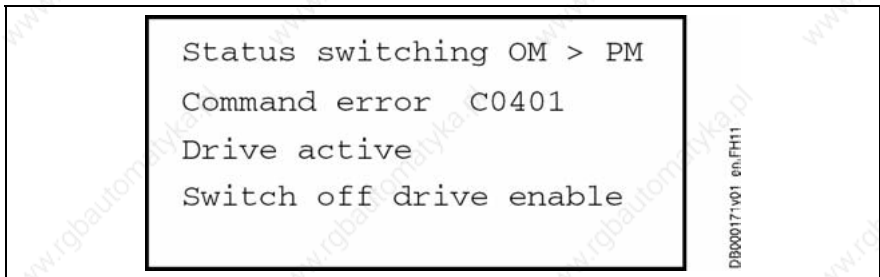

Fig. 7-27: Error message when switching operating mode/parameter mode  
Switch off drive enable and repeat procedure.

### Load Basic Parameters

- Select **Load basic parameters**.
- Press ▶ key.  
Following display appears:

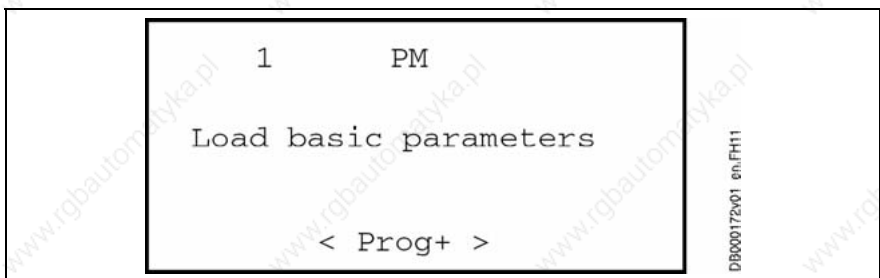

Fig. 7-28: Load basic parameters

- Press **Prog<sup>+</sup>** key.  
Basic parameters are loaded.
- If you don't want to load basic parameters:  
Press **◀** key.

### Save/Load Parameters (Copying Parameter Sets)

You can save the parameter set of a drive controller on the comfort control panel and then load the parameter set which was saved to another drive controller. The parameter set which was saved contains the parameters from the list of backup parameters.

### Requirements

**Note:** To use this function you need a comfort control panel of version VCP01.2BWA-TS-NN-FW (see type plate of comfort control panel).

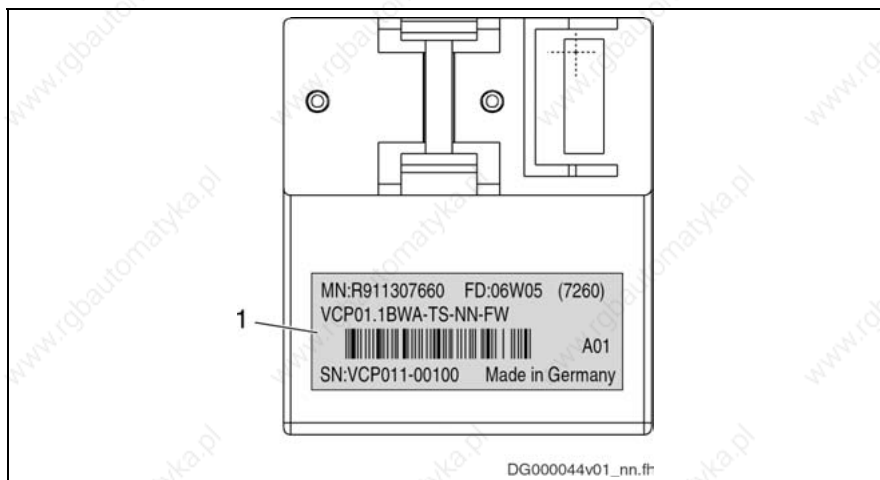

1: Type plate on the back of the comfort control panel

Fig. 7-29: Type plate of the comfort control panel

To use this function

- the functional package "**Open-Loop**" must be active in the firmware which is used and
- the drive controller **with comfort control panel plugged** must have **booted**

### Save Parameters

- Go to main screen.  
By pressing key **◀** several times you get to main screen. By means of **Esc** key, you might possibly have to exit editing mode before.
- Press key **▶**.  
Mode selection is displayed.
- Select **Parameter management**
- Press key **▶**.  
Parameter mode is automatically displayed. Following display appears:

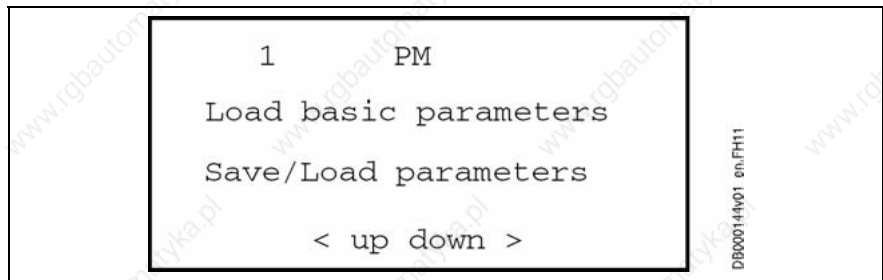

Fig. 7-30: Parameter management

When drive controller was in status AF (drive enable), following display appears:

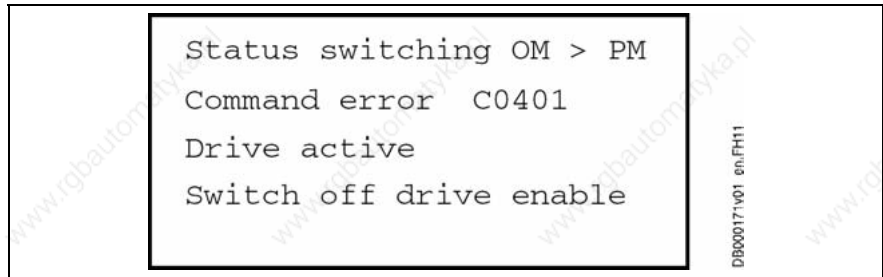

Fig. 7-31: Error message when switching operating mode/parameter mode

Switch off drive enable and repeat procedure.

- Select **Save/load parameters**.
- Press key ►.  
Following display appears:

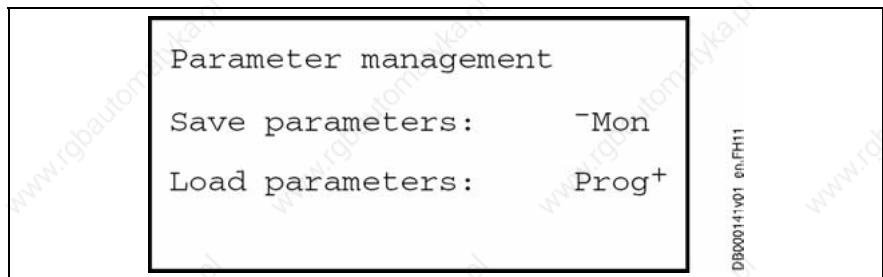
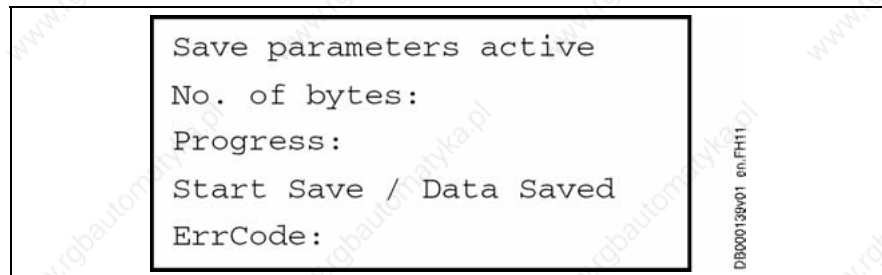

Fig. 7-32: Parameter management

- Press **Mon** key.  
At start of process, **Start Save** is displayed (see following figure) and parameter set is copied to comfort control panel. At the same time, number of **bytes** already copied is displayed. By means of numbers, **Progress** shows you current status of process (on the right there is the end number; to the left of the end number there is the current number).  
**Data Saved** indicates successful end of process.  
If an error occurred, the corresponding message is displayed in lowest line. In this case you have to remove error first and then restart process.



ErrCode: Displayed only in the case of an error (e.g. "Err at Init")

Fig. 7-33: Save parameters

#### Load Parameters

- Plug comfort control panel with copied parameter set on drive controller to which parameter set is to be loaded.
- **Reboot drive controller** with comfort control panel plugged.
- Go to main screen.  
By pressing key **◀** several times you get to main screen. By means of **Esc** key, you might possibly have to exit editing mode before.
- Press key **▶**.  
Mode selection is displayed.
- Select **Parameter management**
- Press key **▶**.  
Parameter mode is automatically displayed. Following display appears:

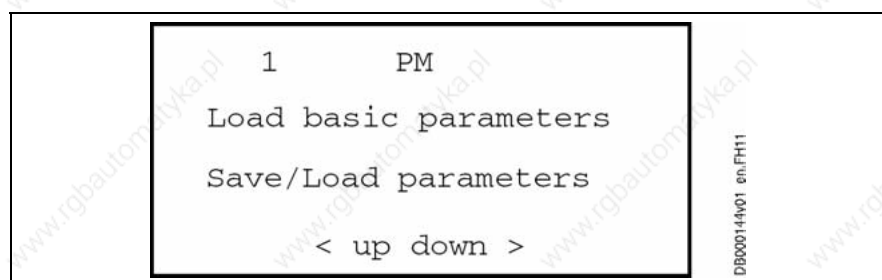

Fig. 7-34: Parameter management

When drive controller was in status AF (drive enable), following display appears:

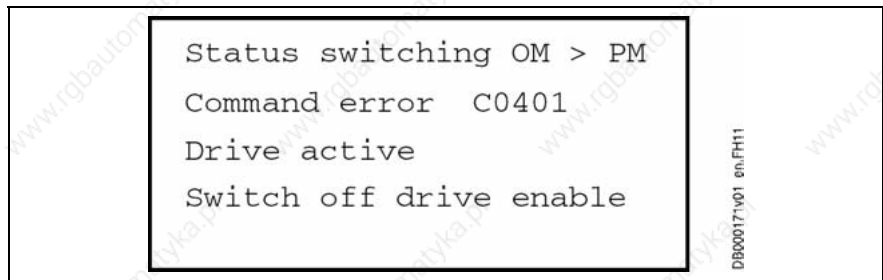

Fig. 7-35: Error message when switching operating mode/parameter mode  
Switch off drive enable and repeat procedure.

- Select **Save/Load parameters**
- Press key ►.  
Following display appears:

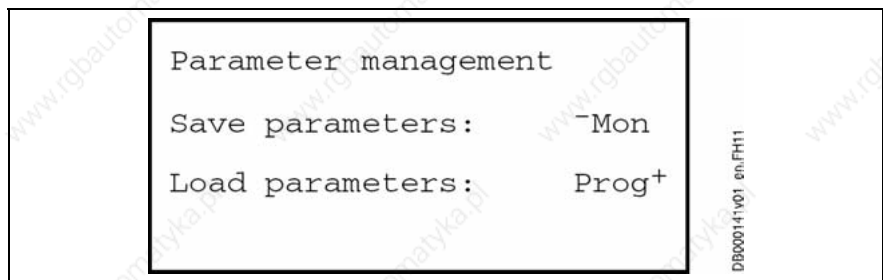
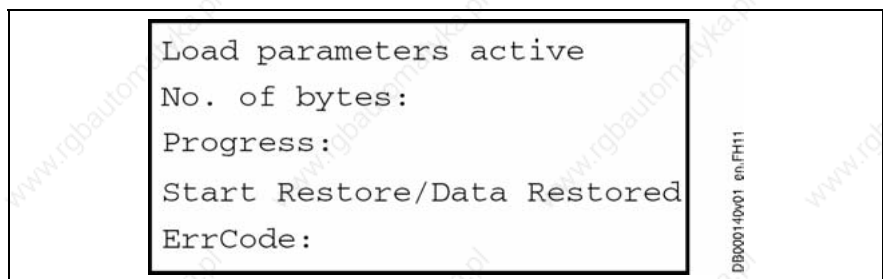

Fig. 7-36: Parameter management

- Press **Prog+** key.  
At start of process, **Start Restore** is displayed (see following figure) and parameter set is loaded to drive controller. At the same time, number of **bytes** already loaded is displayed. By means of numbers, **Progress** shows you current status of process (on the right there is the end number; to the left of the end number there is the current number).  
**Data Restored** indicates successful end of process.  
If an error occurred, the corresponding message is displayed in lowest line. In this case you have to remove error first and then restart process.



ErrCode: Displayed only in the case of an error (e.g. "Err at Init")

Fig. 7-37: Load parameters

## 7.3 Overview of Parameters – Base Package

This chapter contains the parameters of firmware MPx-04 which are relevant for open-loop or closed-loop applications.

### S-0-0000 – S-0-0100

#### S-0-0030, Manufacturer version

	Input min/max:	Default value:	Unit:
MPB:	--- / ---	---	--

**Function** This parameter contains the drive firmware version in the form of a text (ASCII format).  
See also Functional Description "System Overview"

#### S-0-0032, Primary mode of operation

	Input min/max:	Default value:	Unit:
MPB:	--- / ---	2	--

**Function** The operating mode determined in this parameter is activated in the drive, if:

- the primary mode of operation was selected in the master control word
- (bits 8 and 9 = "00") and
- control and power sections are ready for operation and
- drive enable "RF" was set.

See also Functional Description "Selecting the Operating Mode"

#### S-0-0033, Secondary operation mode 1

	Input min/max:	Default value:	Unit:
MPB:	--- / ---	2	--

**Function** The operating mode determined in this parameter is activated in the drive, if:  
the secondary operating mode 1 was selected in the master control word (bits 8 and 9 = "01"),

- control and power sections are ready for operation and
- drive enable "RF" was set.

See also Functional Description "Selecting the Operating Mode"

#### S-0-0034, Secondary operation mode 2

	Input min/max:	Default value:	Unit:
MPB:	--- / ---	2	--

**Function** The operating mode determined in this parameter is activated in the drive, if:

- the secondary operating mode 2 was selected in the master control word (bits 8 and 9 = "10"),
- control and power sections are ready for operation and
- drive enable "RF" was set.

See also Functional Description "Selecting the Operating Mode"

### S-0-0035, Secondary operation mode 3

	Input min/max:	Default value:	Unit:
MPB:	--- / ---	2	--

**Function** The operating mode determined in this parameter is activated in the drive, if:

- the secondary operating mode 3 was selected in the master control word (bits 8 and 9 = "11"),
- control and power sections are ready for operation and
- drive enable "RF" was set.

See also Functional Description "Selecting the Operating Mode"

### S-0-0036, Velocity command value

	Input min/max:	Default value:	Unit:
MPB:		0	S-0-0044

**Function** In the "velocity control" mode the control unit cyclically enters the command value in this parameter.

---

**Note:** The velocity command value actually effective (addition of all components that generate the velocity command value) at the input of the velocity loop is displayed in parameter P-0-0048.

---

See also Functional Description "Operating Modes - Velocity Control"

### S-0-0037, Additive velocity command value

	Input min/max:	Default value:	Unit:
MPB:		0	S-0-0044

**Function** In velocity-controlled and position-controlled operating modes, the control unit can cyclically enter an additive command value in this parameter in case the control unit provides the respective value.

---

**Note:** The velocity command value actually effective (addition of all components that generate the velocity command value) at the input of the velocity loop is displayed in parameter P-0-0048.

---

See also Functional Description "Operating Modes - Velocity Control"

### S-0-0038, Positive velocity limit value

	Input min/max:	Default value:	Unit:
--	----------------	----------------	-------

**MPB:** --- S-0-0044

**Function** Depending on the application, this parameter indicates the value for the maximum allowed positive velocity command value of the motor.

See also Functional Description "Velocity Limitation"

### S-0-0039, Negative velocity limit value

	Input min/max:	Default value:	Unit:
<b>MPB:</b>	---	---	S-0-0044

**Function** Depending on the application, this parameter indicates the value for the maximum allowed negative velocity command value of the motor.

See also Functional Description "Velocity Limitation"

### S-0-0040, Velocity feedback value

	Input min/max:	Default value:	Unit:
<b>MPB:</b>	--- / ---	---	S-0-0044

**Function** The actual velocity value of the motor encoder can be transmitted by the drive controller to the control unit either cyclically or via the service channel.

---

**Note:** In open-loop operation, parameter S-0-0040 contains the actual velocity value estimated by means of a motor model.

---

See also Functional Description "Operating Modes - Velocity Control"

### S-0-0044, Velocity data scaling type

	Input min/max:	Default value:	Unit:
<b>MPB:</b>	--- / ---	2	--

**Function** The scaling type of the velocity data determines in which format and which reference the velocity data are exchanged between the drive and the control unit or user interface.

See also Functional Description "Scaling of Physical Data"

### S-0-0082, Torque/force limit value positive

	Input min/max:	Default value:	Unit:
<b>MPB:</b>		400,0	S-0-0086

**Function** This parameter allows determining a torque or force limit value for positive torque/force command values. This limit value only takes effect with regard to the torque command value of the velocity controller (P-0-0049) and not with regard to command values from the acceleration feedforwards (S-0-0348, P-0-1126). Positive torque takes effect in the case of:

- motive operation at positive velocity



- regenerative operation at negative velocity

See also Functional Description "Torque/Force Limitation"

### S-0-0083, Torque/force limit value negative

	Input min/max:	Default value:	Unit:
MPB:		---	S-0-0086

**Function** This parameter allows determining a torque or force limit value for negative torque/force command values. This limit value only takes effect with regard to the torque command value of the velocity controller (P-0-0049) and not with regard to command values from the acceleration feedforwards (S-0-0348, P-0-1126). Negative torque takes effect in the case of:

- motive operation at negative velocity
- regenerative operation at positive velocity

See also Functional Description "Torque/Force Limitation"

### S-0-0084, Torque/force feedback value

	Input min/max:	Default value:	Unit:
MPB:	--- / ---	---	S-0-0086

**Function** Display parameter for the actual torque/force value currently effective.

#### Calculating the actual torque/force value

$$\text{actual torque/force value} = \text{torque-generating current, actual value (P-0-0043)} * \text{torque factor}$$

Fig. 7-38: Relation for calculating the actual torque/force value

**Note:** The value displayed in S-0-0084 is only an approximation of the torque or the force of the motor actually generated!

See also Functional Description "Torque/Force Limitation"

### S-0-0085, Torque/force polarity parameter

	Input min/max:	Default value:	Unit:
MPB:	0 / 7	0	--

**Function** In this parameter it is possible to invert the polarities of the indicated torque/force data with regard to the application. The polarities are changed outside of the controlled system, i.e. at the input and output of the controlled system.

#### The following applies to rotary motors:

A clockwise turn of the motor output shaft in the case of positive torque and positive polarity.

#### The following applies to linear motors:

A move of the primary part in the direction of the cable connection side in the case of positive force and positive polarity.

See also Functional Description "Scaling of Physical Data"

### S-0-0086, Torque/force data scaling type

	Input min/max:	Default value:	Unit:
MPB:	--- / ---	0	--

**Function** The unit and reference of the torque/force data of a drive are set by this parameter:

- percentage-based scaling (% of reference value, see below)
- rotary scaling (Nm, inlbf)
- linear scaling (N, lbf)

See also Functional Description "Scaling of Physical Data"

### S-0-0091, Bipolar velocity limit value

	Input min/max:	Default value:	Unit:
MPB:		10000000	S-0-0044

**Function** Depending on the application, this parameter indicates the value for the maximum allowed velocity command value of the motor, independent of the sense of rotation.

The maximum value for S-0-0091 is the value of "S-0-0113, Maximum motor speed". This value also is the maximum value for all other velocity parameters.

Depending on the sense of rotation, the maximum velocity limit can be influenced by the parameters "S-0-0038, Positive velocity limit value" and "S-0-0039, Negative velocity limit value". These two parameters have the default value "0" and thereby are switched off, only S-0-0091 takes effect.

See also Functional Description "Velocity Limitation"

### S-0-0092, Bipolar torque/force limit value

	Input min/max:	Default value:	Unit:
MPB:		400,0	S-0-0086

**Function** By this parameter it is possible to limit the torque/force command value to allowed maximum values in order to protect the mechanical components.

See also Functional Description "Torque/Force Control"

### S-0-0093, Torque/force data scaling factor

	Input min/max:	Default value:	Unit:
MPB:	--- / ---	---	--

**Function** This parameter is always adapting itself to the selected preferred scaling. The parameter cannot be changed!

---

**Note:** Freely parameterizable scaling (parameter scaling) is impossible for the torque/force data!

---

See also Functional Description "Torque/Force Control"

### S-0-0094, Torque/force data scaling exponent

	Input min/max:	Default value:	Unit:
MPB:	--- / ---	---	--

**Function** This parameter is always adapting itself to the selected preferred scaling. The parameter cannot be changed!

---

**Note:** Freely parameterizable scaling (parameter scaling) is impossible for the torque/force data!

---

### S-0-0095, Diagnostic message

	Input min/max:	Default value:	Unit:
MPB:	--- / ---	---	--

**Function** This parameter contains the operating status of the drive at present relevant in the form of a **text**.  
 Preceding the text is the respective content of parameter **S-0-0390, Diagnostic message number**.

**Example:** "A0010 Drive HALT"

See also Functional Description "Coded Diagnostic Drive Messages"

### S-0-0100, Velocity loop proportional gain

	Input min/max:	Default value:	Unit:
MPB:	0,000 / 2147483,647	0,050	P-0-4014

**Function** The speed loop generates a torque/force command value (P-0-0049) from the difference of velocity command value and actual velocity value (= **S-0-0347, Velocity error**).

See also Functional Description "Control Loop Structure"

See also Functional Description "Operating Modes - Velocity Control"

## S-0-0101 – S-0-0200

### S-0-0101, Velocity loop integral action time

	Input min/max:	Default value:	Unit:
MPB:	0,0 / 6553,5	100,0	ms

**Function** The speed controller generates a torque/force command value (P-0-0049) from the difference of velocity command value and actual velocity value (= **S-0-0347, Speed deviation**).

See also Functional Description "Operating Modes - Velocity Control"

**S-0-0106, Current loop proportional gain 1**

	Input min/max:	Default value:	Unit:
MPB:	0,00 / 500,00	8,00	V/A

**Function** This parameter is used to define the P-gain for the current loop (for the  $I_d$  and  $I_q$  control loop). Parameterization of the current loop proportional gain depends on the control performance (current loop clock  $T_{A,i}$ ) and the selected switching frequency (cf. P-0-0001).

**S-0-0107, Current loop integral action time 1**

	Input min/max:	Default value:	Unit:
MPB:	0,0 / 429496729,5	2,0	ms

**Function** The value for the current loop integral action time 1 is motor-specific and is determined individually for each motor type.

**S-0-0109, Motor peak current**

	Input min/max:	Default value:	Unit:
MPB:	0,000 / 1000,000	5,000	A eff

**Function** Maximum allowed current that may temporarily flow in the motor.  
See also Functional Description "Limitations"

**S-0-0110, Amplifier peak current**

	Input min/max:	Default value:	Unit:
MPB:	--- / ---	---	A eff

**Function** Peak current of the controller. The value is set automatically by the device. This current is only available temporarily.

See also Functional Description "Current Limitation"

**S-0-0111, Motor current at standstill**

	Input min/max:	Default value:	Unit:
MPB:	0,000 / 500,000	1,000	A eff

**Function** The value of this parameter is the torque-/force-generating component of the continuous motor current when the motor is loaded with the least allowed cooling type, with the continuous torque ensured at standstill or with the ensured continuous force (see motor data sheet).

See also Functional Description "Rexroth Motors"

**S-0-0112, Amplifier nominal current**

	Input min/max:	Default value:	Unit:
MPB:	--- / ---	---	A eff

**Function** This parameter displays the maximum possible continuous current of the drive.

---

**Note:** In the case of rotary field frequencies smaller than 3 Hz, the possible amplifier continuous current is reduced by means of a temperature model (see Technical Data in hardware Project Planning Manual!).

---

See also Functional Description "Current Limitation"

### S-0-0113, Maximum motor speed

	Input min/max:	Default value:	Unit:
<b>MPB:</b>		3000,0000	S-0-0044

**Function** Value for the maximum allowed velocity command value of the motor. The actual velocity value may be a maximum of 12.5% higher than the value of S-0-0113, with higher actual values the drive reacts with torque disable and generates the error message **F8079 Velocity limit S-0-0091 exceeded**.

See also Functional Description "Limitations"

### S-0-0127, C0100 Communication phase 3 transition check

	Input min/max:	Default value:	Unit:
<b>MPB:</b>	--- / ---	---	--

**Function** When executing the **S-0-0127, C0100 Communication phase 3 transition check** command, all interface parameters are checked for validity.

See also Functional Description "Device Control (Status Machine)"

### S-0-0128, C5200 Communication phase 4 transition check

	Input min/max:	Default value:	Unit:
<b>MPB:</b>	--- / ---	---	--

**Function** When executing the command **S-0-0128, C0200 Communication phase 4 transition check** is executed, all parameters are checked for validity and possible limit value violations.

See also Functional Description "Device Control (Status Machine)"

### S-0-0134, Master control word

	Input min/max:	Default value:	Unit:
<b>MPB:</b>	--- / ---	---	--

**Function** For drives with SERCOS interface the master control word is cyclically transmitted from master to drive.

There is important control information defined in the master control word, like for example:

- drive enable
- Drive Halt
- selection of command operating mode

See also Functional Description "Device Control (Status Machine)"

See also Functional Description "System Overview - Master Communication - SERCOS interface"

See also Functional Description "Drive Functions – Drive Halt"

### S-0-0135, Drive status word

	Input min/max:	Default value:	Unit:
MPB:	--- / ---	---	--

**Function** For drives with SERCOS interface the master status word is cyclically transmitted from drive to master. There is important status information contained in the master status word, like for example:

- readiness for operation of control and power sections
- drive error
- change bits class 2 and 3 diagnostics
- current operating mode

See also Functional Description "Device Control (Status Machine)"

See also Functional Description "System Overview - Master Communication - SERCOS interface"

See also Functional Description "Drive Functions – Drive Halt"

### S-0-0140, Controller type

	Input min/max:	Default value:	Unit:
MPB:	--- / ---	---	--

**Function** The power section type is contained in the operating data of this parameter in the form of a text (e.g. HCS02.1).

See also Functional Description "Controller Design"

### S-0-0141, Motor type

	Input min/max:	Default value:	Unit:
MPB:	--- / ---	---	--

**Function** The type designation of the motor is entered in this parameter.

See also Functional Description "Motor, Mechanical Axis System, Measuring Systems"

### S-0-0142, Application type

	Input min/max:	Default value:	Unit:
MPB:	--- / ---	---	--

**Function** A descriptive name (text) for the drive or the axis (e.g. swiveling axis) can be stored in this parameter.

**Note:** It does not have any influence on the function.

### S-0-0144, Signal status word

	Input min/max:	Default value:	Unit:
MPB:	--- / ---	---	--

**Function** By means of the signal status word it is possible to transmit signals in real time from the drive to the control unit.

See also Functional Description "Configurable Signal Status Word"

### S-0-0145, Signal control word

	Input min/max:	Default value:	Unit:
MPB:	--- / ---	---	--

**Function** By means of the signal control word it is possible to transmit signals in real time from the control unit to the drive.

See also Functional Description "Configurable Signal Control Word"

### S-0-0160, Acceleration data scaling type

	Input min/max:	Default value:	Unit:
MPB:	--- / ---	2	--

**Function** As described below, it is possible to set different scaling types for the acceleration data in the drive.

The scaling type of the acceleration data determines in which format and which reference the acceleration data are exchanged between the drive and the control unit or user interface. The values of the acceleration data parameters (e.g. **S-0-0138, Bipolar acceleration limit value**) are displayed by the drive with the scaling that has been set. The scaling setting is normally preset by the control unit.

See also Functional Description "Scaling of Physical Data"

## S-0-0201 – S-0-0300

### S-0-0201, Motor warning temperature

	Input min/max:	Default value:	Unit:
MPB:		145,0	S-0-0208

**Function** If the motor temperature exceeds the motor warning temperature, the drive sets bit 2 (motor overtemperature warning) in **S-0-0012, Class 2 diagnostics** and the warning **E2051 Motor overtemp. prewarning** is output. In the case of MHD and MKD motors, the drive sets this parameter to 145 °C, in the case of MKE motors to 125 °C.

See also Functional Description "Motor Temperature Monitoring"

### S-0-0204, Motor shutdown temperature

	Input min/max:	Default value:	Unit:
MPB:		155,0	S-0-0208

**Function** If the motor temperature exceeds the motor shutdown temperature, the drive sets bit 2 (motor overtemperature shutdown) in **S-0-0011, Class 1 diagnostics** and the error **F2019 Motor overtemperature shutdown** is generated.

In the case of MHD and MKD motors, the drive sets this parameter to 155 °C, in the case of MKE motors to 135 °C.

See also Functional Description "Motor Temperature Monitoring"

### S-0-0208, Temperature data scaling type

	Input min/max:	Default value:	Unit:
MPB:	--- / ---	0	--

**Function** By means of this parameter the unit of the temperature data of the drive is determined. The values are displayed with the first decimal place.

### S-0-0265, Language selection

	Input min/max:	Default value:	Unit:
MPB:	0 / var.	0	--

**Function** All parameter names, units and diagnostic/error messages are stored in the drive controller in several languages. This parameter determines the language of the texts to be output.

- 0: German
- 1: English
- 2: French
- 3: Italian
- 4: Spanish

See also Functional Description "Language Selection"

### S-0-0292, List of all operating modes

	Input min/max:	Default value:	Unit:
MPB:	--- / ---	---	--

**Function** All operating modes that are supported by the drive firmware used are listed in this parameter.

The codes (hexadecimal) of those operating modes are displayed that can be entered in the parameters S-0-0032 ... S-0-0035 and S-0-0284 ... S-0-0287 (primary mode of operation and secondary operation modes) in the form of binary values.

See also Functional Description "Operating Modes"



**S-0-0301 – S-0-0400****S-0-0328, Assign list signal status word**

	Input min/max:	Default value:	Unit:
MPB:	0 / 31	---	--

**Function** In this list parameter the assignment is made which bit of the respective parameter entered in **S-0-0026, Configuration list signal status word** is to be mapped to **S-0-0144, Signal status word**.

See also Functional Description "Configurable Signal Status Word"

**S-0-0329, Assign list signal control word**

	Input min/max:	Default value:	Unit:
MPB:	0 / 31	---	--

**Function** In this list parameter the assignment is made which bit of the respective parameter entered in **S-0-0027, Configuration list signal control word** is written via the signal control word (S-0-0145).

See also Functional Description "Configurable Signal Control Word"

**S-0-0330, Message 'n\_actual = n\_command'**

	Input min/max:	Default value:	Unit:
MPB:	--- / ---	---	--

**Function** This parameter displays whether the actual velocity value has reached the command value within a tolerance window (message "n\_actual = n\_command").

|S-0-0040 – S-0-0036 – S-0-0037| <= S-0-0157

**S-0-0331, Status 'n\_feedback = 0'**

	Input min/max:	Default value:	Unit:
MPB:	--- / ---	---	--

**Function** This parameter displays whether the actual velocity value has fallen below a threshold value that can be set, below which the controller recognizes motor or axis standstill ("n\_feedback = 0" message).

See also Functional Description "Status Classes"

**S-0-0332, Message 'nactual < nx'**

	Input min/max:	Default value:	Unit:
MPB:	--- / ---	---	--

**Function** This parameter displays whether the actual velocity value has fallen below a threshold value that can be set ("n\_actual = nx" message).

See also Functional Description "Status Classes"

**S-0-0333, Message 'T >= Tx'**

	Input min/max:	Default value:	Unit:
MPB:	--- / ---	---	--

**Function** This parameter indicates whether the actual torque or force value has exceeded a threshold value ("T >= Tx" message) that can be set.

See also Functional Description "Status Classes"

**S-0-0334, Message 'T >= Tlimit'**

	Input min/max:	Default value:	Unit:
MPB:	--- / ---	---	--

**Function** This parameter indicates whether the actual torque or force value has reached the limit value ("T >= Tlimit" message).

The limit value is generated by the smallest value of

- **P-0-0109, Torque/force peak limit**
- **S-0-0092, Bipolar torque/force limit value**
- **S-0-0082, Torque/force limit value positive**
- **S-0-0083, Torque/force limit value negative**
- work load-dependent limits by motor and controller.

See also Functional Description "Velocity Limitation"

**S-0-0335, Message 'n command > n limit'**

	Input min/max:	Default value:	Unit:
MPB:	--- / ---	---	--

**Function** This parameter displays when the absolute velocity command value is greater than the velocity limit value that can be set ("n command > n limit" message).

See also Functional Description "Velocity Limitation"

**S-0-0337, Message 'P >= Px'**

	Input min/max:	Default value:	Unit:
MPB:	--- / ---	---	--

**Function** This parameter indicates whether the absolute value of the actual power value has exceeded a threshold value that can be set ("P >= Px" message). Bit 0 of this parameter becomes "1" when the absolute value of **S-0-0382, DC bus power** is greater than or equal to the value of **S-0-0158, Power threshold Px**.

This message also appears in **S-0-0013, Class 3 diagnostics**.

**S-0-0349, Jerk limit bipolar**

	Input min/max:	Default value:	Unit:
<b>MPB:</b>		0	S-0-0160

**Function** The bipolar jerk limit value, in the operating modes listed below, describes the maximum allowed acceleration change per time (= jerk), symmetrically in both directions (acceleration and deceleration).

The limit value takes effect in the following operating modes:

- Position control
- drive-internal interpolation
- drive-controlled positioning

---

**Note:** The bipolar jerk limit value limits the change in acceleration per time for "Drive Halt", the error reaction quick stop (velocity command value reset with filter and ramp) and the commands that are generating their own position command values. The value "0" switches the jerk filter off!

---

See also Functional Description "Establishing the Position Data Reference (Drive Controlled Homing)"

See also Functional Description "Spindle Positioning"

See also Functional Description "Drive Functions - Drive Halt"

**S-0-0375, List of diagnostic numbers**

	Input min/max:	Default value:	Unit:
<b>MPB:</b>	--- / ---	---	--

**Function** The drive enters every change of parameter **S-0-0390, Diagnostic message number** in this list. The list is organized as a ring buffer; it can contain up to 50 diagnostic message numbers. When the list is read, the last diagnostic message number displayed is displayed in the 1<sup>st</sup> element of the parameter.

See also Functional Description "Diagnostic System"

**S-0-0380, DC bus voltage**

	Input min/max:	Default value:	Unit:
<b>MPB:</b>	--- / ---	---	V

**Function** This parameter is used to display the DC bus voltage currently measured.

**S-0-0382, DC bus power**

	Input min/max:	Default value:	Unit:
<b>MPB:</b>	--- / ---	---	Watt

**Function** This parameter displays the DC bus power currently demanded by the motor.

**S-0-0383, Motor temperature**

	Input min/max:	Default value:	Unit:
MPB:	--- / ---	---	S-0-0208

**Function** This parameter indicates the measured value of the winding temperature of the motor, if the temperature sensor incorporated in the motor allows analog temperature evaluation!

**Note:** In the case of MHD, MKD, MKE and LSF motors, the values indicated by S-0-0383 do not allow, due to the temperature sensor characteristic (switching performance), drawing a conclusion regarding the actual motor temperature!

See also Functional Description "Motor Temperature Monitoring"

**S-0-0384, Amplifier temperature**

	Input min/max:	Default value:	Unit:
MPB:	--- / ---	---	S-0-0208

**Function** Display parameter for the measured temperature of the controller power output stage (heat sink temperature).

**S-0-0401 – S-0-1000****S-0-0520, Control word of axis controller**

	Input min/max:	Default value:	Unit:
MPB:	--- / ---	4	--

**Function** The control word of axis controller takes effect in all position-controlled operating modes and allows influencing the axis control.

See also Functional Description "Operating Modes"

**S-0-0521, Status word of position loop**

	Input min/max:	Default value:	Unit:
MPB:	--- / ---	---	--

**Function** The status word of position loop displays current information relevant to position control of the active operating mode.

See also Functional Description "Operating Modes"

**S-0-0822, Torque/force ramp**

	Input min/max:	Default value:	Unit:
MPB:		0,0	S-0-0086

**Function** With the torque/force ramp time (S-0-0823) the torque/force ramp defines an increase for the torque/force command value (S-0-0080) in the operating mode "torque/force control".

**Note:** Parameter S-0-0822 replaces the previously available filtering by means of the PT1 filter (cf. P-0-0176)!

See also Parameter Description "S-0-0822, Torque/force ramp"

See also Parameter Description "S-0-0824, Message torque/force command value reached"

See also Functional Description "Operating Modes - Torque/Force Control"

### S-0-0823, Torque/force ramp time

	Input min/max:	Default value:	Unit:
MPB:	0,0 / 6553,5	0,0	ms

**Function** The torque/force ramp time (S-0-0823) is the reference time for the torque/force ramp. In the operating mode torque/force control, the parameter S-0-0823, together with the torque/force ramp (S-0-0822), defines an increase for the torque/force command value (S-0-0080).

See also Parameter Description "S-0-0822, Torque/force ramp"

See also Parameter Description "S-0-0824, Message torque/force command value reached"

See also Functional Description "Operating Modes - Torque/Force Control"

### S-0-0824, Message torque/force command value reached

	Input min/max:	Default value:	Unit:
MPB:	--- / ---	---	--

**Function** In the operating mode "torque/force control", the message "**S-0-0824, Message torque/force command value reached**" indicates that the internal "**S-0-0080, Torque/force command value**" has reached the preset value.

See also Functional Description "Operating Modes"

## P-0-0001 – P-0-0689 (General Functions)

### P-0-0001, Switching frequency of the power output stage

	Input min/max:	Default value:	Unit:
MPB:	4000 / 8000	4000	Hz

**Function** The switching frequency of the power output stage can be set. The max. switching frequency is determined by **P-0-4058, Amplifier type data**, list element 16. Depending on the device type, the following values can be set, for example:

Device type / switching frequ. fs [kHz]	2	4	8	12	16
HCS02	O	X	X	X	X
HCS03	O	X	X	X	X

HCS04 (as of MPx04)	X	X	X	X	O
HMS01	O	X	X	X	X
HMS02 (as of MPx04)	O	X	X	O	O
HMD01	O	X	X	O	O

O not allowed  
X allowed

Fig. 7-39: Switching frequency

**Note:** Only set such switching frequencies which are supported by the involved components! Observe the Technical Data for drive controllers and motors.

See also Functional Description "Current Controller"

### P-0-0004, Velocity loop smoothing time constant

	Input min/max:	Default value:	Unit:
MPB:	0 / 65500	800	us

**Function** The time constant that can be activated in this parameter takes effect in the velocity controller and is suited for suppressing quantization effects and limiting the bandwidth of the velocity control loop.

See also Functional Description "Velocity Control Mode"

The limit frequency results from the smoothing time constant by means of the following relationship:

$$f_g = \frac{1}{2 \cdot \pi \cdot T}$$

Fig. 7-40: Bandwidth

By inputting the minimum input value the filter is switched off.

### P-0-0007, Display text of diagnostic message

	Input min/max:	Default value:	Unit:
MPB:	--- / ---	---	--

**Function** This parameter contains the display text currently displayed on the control panel of the drive.

**Example:** " AF" or " PL"

See also Functional Description "Coded Diagnostic Drive Messages"

### P-0-0008, Activation E-Stop function

	Input min/max:	Default value:	Unit:
MPB:	0 / 7	0	--

- Function** This parameter is used for activating the E-Stop input and selecting a reaction for the shutdown of the drive.  
See also Functional Description "E-Stop Function"  
See also Functional Description "Activation and Polarity of the E-Stop Input"

### P-0-0009, Error number

	Input min/max:	Default value:	Unit:
MPB:	--- / ---	---	--

- Function** When the drive diagnoses a class 1 diagnostics error, a bit is set in parameter **S-0-0011, Class 1 diagnostics**. Bit 13 for "Error in class 1 diagnostics" is then set in the drive status word.  
  
See also Functional Description "Error Memory (Power Section and Control Section)"

### P-0-0018, Number of pole pairs/pole pair distance

	Input min/max:	Default value:	Unit:
MPB:	1 / var.	3	P-0-4014

- Function** The following settings can be made depending on bit 9 of parameter **P-0-4014, Type of construction of motor**:
- number of pole pairs in the case of rotary motors
  - pole pair distance/pole pair length in the case of linear motors

---

#### Note:

Writing the correct value to this parameter:

- In the case of MHD, MKD, MKE, automatically at initial commissioning.
  - In the case of 2AD, ADF, linear and rotary kit motors, by loading the motor parameters with the IndraWorks D commissioning tool.
  - In the case of other motors, manual input according to manufacturer's specification.
- 

See also Functional Description "Motor, Mechanical Axis System, Measuring Systems"

### P-0-0043, Torque-generating current, actual value

	Input min/max:	Default value:	Unit:
MPB:	--- / ---	---	A eff

- Function** Display parameter for the torque-generating component of the measured actual current value. The value is updated with the current loop cycle time.

---

**Note:** The phase currents of the three-phase AC motor are measured. The resulting torque-generating content of the total current is calculated internally and displayed by means of this parameter.

---

### P-0-0044, Flux-generating current, actual value

	Input min/max:	Default value:	Unit:
MPB:	--- / ---	---	A eff

**Function** Display parameter for the content of the measured actual current value that generates the magnetic flux in the motor. The value is updated with current loop cycle time.

---

**Note:** The phase currents of the three-phase AC motor are measured. The resulting flux-generating content of the total current is calculated internally and displayed by means of this parameter.

---

### P-0-0045, Control word of current controller

	Input min/max:	Default value:	Unit:
MPB:	--- / ---	0	--

**Function** This parameter is used to configure the current controller. This means that with this parameter you can activate and deactivate extended functions.

See also Functional Description "Motor Control"

### P-0-0046, Status word of current controller

	Input min/max:	Default value:	Unit:
MPB:	--- / ---	---	--

**Function** This parameter displays states that affect the correct behavior of the current loop.

### P-0-0048, Effective velocity command value

	Input min/max:	Default value:	Unit:
MPB:	--- / ---	---	S-0-0044

**Function** By means of this parameter it is possible to display the velocity command value at the summing point of the velocity controller.

---

**Note:** At the summing point the actual velocity value is subtracted from the effective velocity command value. The result of this calculation (control difference) is the input of the speed controller.

---



See also the functional description: "Velocity Loop"

See also the functional description: "Synchronization Modes"

### P-0-0051, Torque/force constant

	Input min/max:	Default value:	Unit:
<b>MPB:</b>	0,01 / 21474836,47	1,00	P-0-4014

**Function** The torque/force constant indicates the relation of the motor torque/force and the associated torque-generating current of the motor, if the motor is not in the field weakening range.

If the motor is in the field weakening range, the actually effective torque/force constant is reduced depending on the speed/velocity. The value in this parameter, however, remains unchanged (relation to operation without field weakening).

---

#### Note:

Writing the correct value to this parameter:

- In the case of MHD, MKD, MKE, automatically at initial commissioning.
- In the case of 2AD, ADF, linear and rotary kit motors, by loading the motor parameters with the IndraWorks D commissioning tool.
- In the case of other motors, manual input according to manufacturer's specification.

---

See also Functional Description "Torque/Force Control"

See also Functional Description "Motor, Mechanical Axis System, Measuring Systems"

### P-0-0059, Additive position command value, controller

	Input min/max:	Default value:	Unit:
<b>MPB:</b>		0	S-0-0076

**Function** By means of this parameter an additional position command value can be added, directly at the input of the position loop, to the position command value generated by command value adjustment. The value is neither limited nor changed. This is why the user has to make sure that absolute value, characteristic and the derived values are within their allowed ranges of values!

---

**Note:** The actually effective position command value (addition of position command value from command value adjustment of current operating mode and "additive position command value, controller") is displayed in parameter **P-0-0434, Position command value of controller**.

---

This parameter is used, for example, by the drive firmware in order to set command values from the firmware-internal command value generator without limitation and deformation (noise generator for control loop analysis). It can also be used by the control master for adding feedforward values, for example!

See also Functional Description "Position Control with Cyclic Command Value Input"

### P-0-0063, Torque-generating voltage, actual value

	Input min/max:	Default value:	Unit:
MPB:	--- / ---	---	V eff

**Function** Display parameter for the torque-generating component of the voltage output by the current loop. The value is updated with the current loop cycle time.

### P-0-0064, Flux-generating voltage, actual value

	Input min/max:	Default value:	Unit:
MPB:	--- / ---	---	V eff

**Function** Display parameter for the flux-generating component of the voltage output by the current loop. The value is updated with the current loop cycle time.

### P-0-0065, Absolute voltage value, actual value

	Input min/max:	Default value:	Unit:
MPB:	--- / ---	---	V eff

**Function** This parameter displays the absolute value of the voltage output by the current loop which consists of the voltage components  $U_d$  and  $U_q$ .

---

**Note:** The displayed voltage value corresponds to the measured value available at the motor terminals (conductor reference) and is updated with the current loop cycle time!

---

See also Functional Description "Motor Control"

### P-0-0067, Phase current U, actual value

	Input min/max:	Default value:	Unit:
MPB:	--- / ---	---	A

**Function** This parameter is used to display the actual current value in the motor phase U measured in the current loop clock ( $T_{A, \text{current}}$ ).

See also Functional Description "Performance Data"

### P-0-0068, Phase current V, actual value

	Input min/max:	Default value:	Unit:
MPB:	--- / ---	---	A

**Function** This parameter is used to display the actual current value in the motor phase V measured in the current loop clock ( $T_{A, \text{current}}$ ).

See also Functional Description "Performance Data"

**P-0-0081, Parallel output 1**

	<b>Input min/max:</b>	<b>Default value:</b>	<b>Unit:</b>
<b>MPB:</b>	--- / ---	---	--

**Function** The content of **P-0-0081, Parallel output 1** is output at the digital outputs of the optional cards "MD1" (7 outputs) or "MD2" (16 outputs).

---

**Note:** By writing P-0-0081 (e.g. by means of MLD) the digital outputs can be directly addressed.

---

See also Functional Description "Digital Inputs/Outputs"

**P-0-0082, Parallel input 1**

	<b>Input min/max:</b>	<b>Default value:</b>	<b>Unit:</b>
<b>MPB:</b>	--- / ---	---	--

**Function** The content of **P-0-0082, Parallel input 1** maps the digital inputs of the option MD1 (11 inputs) or MD2 (16 inputs).

---

**Note:** By reading P-0-0082 (e.g. by means of MLD) the digital inputs can be directly detected.

---

See also Functional Description "Digital Inputs/Outputs"

**P-0-0090, Travel range limit parameter**

	<b>Input min/max:</b>	<b>Default value:</b>	<b>Unit:</b>
<b>MPB:</b>	0 / 7	0	--

**Function** This parameter defines the signal behavior of the travel range limit switch inputs and the behavior of the drive with regard to exceeded travel ranges.

See also Functional Description "Position Limitation/Travel Range Limit Switch"

**P-0-0101, Configuration for starting lockout selector**

	<b>Input min/max:</b>	<b>Default value:</b>	<b>Unit:</b>
<b>MPB:</b>	--- / ---	0	--

**Function** In parameter **P-0-0101, Configuration for starting lockout selector** it is possible to configure the selection of the activation circuit of the starting lockout.

**Parameter structure:**

Bit	Designation/function	Comment
0	0: N/C-N/O combination 1: N/C-N/C combination	

Fig. 7-41: P-0-0101, Configuration for starting lockout selector

### P-0-0102, Oper. hours power section at last activat. of start. lockout

	Input min/max:	Default value:	Unit:
MPB:	--- / ---	0,0	s

**Function** Parameter **P-0-0102, Oper. hours power section at last activat. of start. lockout** displays the operating hours of the power section since the last time the starting lockout function was deselected.

### P-0-0105, Time stamp for list of diagnostic message numbers

	Input min/max:	Default value:	Unit:
MPB:	--- / ---	---	s

**Function** This parameter contains a list of the points of time at which the diagnostic drive message was changed. At each change of **S-0-0390, Diagnostic message number** the respective point of time (value from **P-0-0190, Operating hours control section**) is recorded. The last point of time at which the diagnostic message was changed is entered in the first line of the list, all entries already existing are moved down by one line. The list is full after 50 entries, each other entry causes the oldest value to get lost.

The list from P-0-0105 corresponds with **S-0-0375, List of diagnostic numbers**. These parameters in the same line contain the diagnostic message number corresponding to the respective point of time.

---

**Note:** The numbers of the diagnostic error messages and the respective points of time of the error events are only accepted in S-0-0375 and P-0-0105 by clearing the error message!

---

### P-0-0109, Torque/force peak limit

	Input min/max:	Default value:	Unit:
MPB:		400,0	S-0-0086

**Function** Torque/force limit value that acts on the sum of all torque/force command values:

- command values from the acceleration feedforwards (S-0-0348, P-0-1126)
- command values from the velocity controller (P-0-0049)

See also Functional Description "Torque/Force Limitation"

### P-0-0114, Undervoltage threshold

	Input min/max:	Default value:	Unit:
MPB:	0 / 500	0	V

**Function** With this parameter it is possible to determine and activate an individual undervoltage threshold, differing from the standard value, for the DC bus voltage.

### P-0-0115, Device control: status word

	Input min/max:	Default value:	Unit:
MPB:	--- / ---	---	--

**Function** By means of this parameter it is possible to read the drive status (→ device control) independent of the master communication that is used.  
See also Functional Description "Master Communication"  
See also Functional Description "Drive Functions - Drive Halt"

### P-0-0116, Device control: control word

	Input min/max:	Default value:	Unit:
MPB:	--- / ---	---	--

**Function** This parameter indicates whether the master communication has activated the drive.

### P-0-0117, Activation of NC reaction on error

	Input min/max:	Default value:	Unit:
MPB:	--- / ---	0	--

**Function** This parameter allows activating an error reaction controlled by the control unit. When error reaction controlled by the control unit is active, the control unit (external control/NC or local MLD) still can input command values for the drive for 30 s. This allows realizing an error reaction coordinated by the control unit in the case of error.

---

**Note:** When the 30 seconds are over, the error reaction set in **P-0-0119, Best possible deceleration** is carried out.

---

See also Functional Description "NC Reaction on Error"

### P-0-0118, Power supply, configuration

	Input min/max:	Default value:	Unit:
MPB:	--- / ---	3	--

**Function** In parameter P-0-0118 settings with regard to error messages and error reactions are made for drives that are interconnected via the DC bus and the module bus ("drive system"). In addition, the handling of DC bus undervoltage is determined.

---

**Note:** The DC bus voltage (power bus) for the "drive system" in operation is not switched off in the case of non-fatal drive errors!

---

See also Functional Description "Power Supply"

**P-0-0119, Best possible deceleration**

	Input min/max:	Default value:	Unit:
<b>MPB:</b>	0 / 3	0	--

- Function** This parameter determines the way the drive is shut down in case
- non-fatal errors occur
  - interface errors occur
  - communication phase is reset
  - drive enable is disabled

See also Functional Description "Best Possible Deceleration"

**P-0-0139, Analog output 1**

	Input min/max:	Default value:	Unit:
<b>MPB:</b>	0,000 / 10,000	0,000	V

- Function** This parameter indicates the voltage value that is output via the analog output 1 of the drive controller.

See also Functional Description "Analog Outputs"

**P-0-0140, Analog output 2**

	Input min/max:	Default value:	Unit:
<b>MPB:</b>	0,000 / 10,000	0,000	V

- Function** This parameter indicates the voltage value that is output via the analog output 2 of the drive controller.

See also Functional Description "Analog Outputs"

**P-0-0141, Thermal drive load**

	Input min/max:	Default value:	Unit:
<b>MPB:</b>	0,0 / 100,0	---	%

- Function** The **P-0-0141, Thermal drive load** parameter is used to check the thermal load of the amplifier, 0% of the chip overtemperature corresponding to 0 Kelvin, 100% corresponding to the maximum chip overtemperature. Given the correct dimensioning of the drive, the thermal load should not exceed the value of 80% for the intended processing cycles.

**P-0-0180, Acceleration feedforward smoothing time constant**

	Input min/max:	Default value:	Unit:
<b>MPB:</b>	0 / 10000	0	us

- Function** This parameter allows filtering the

- double differentiated position command value (cyclic position control)
  - differentiated velocity command value (velocity control)
- with a 1<sup>st</sup> order low pass in order to realize an acceleration feedforward which avoids an unduly high excitation of the system even in the case of poor position or velocity resolution. For the double differentiation can cause a highly noisy feedforward value which in turn is added as an additive torque command value.

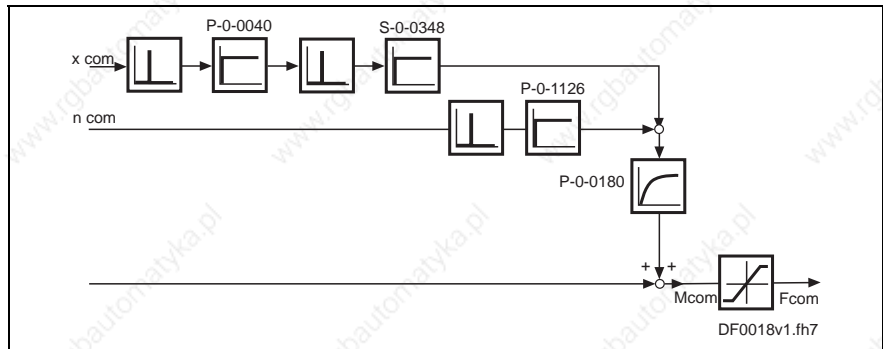

Fig. 7-42: Parameterizable filter cascade

See also Functional Description "Drive Control - Axis Control (Closed-Loop Operation)"

### P-0-0190, Operating hours control section

	Input min/max:	Default value:	Unit:
MPB:	--- / ---	---	s

**Function** This parameter displays the operating time of the drive's control section. By means of this parameter it is possible to display the total duty cycle of the control electronics since the delivery of the device. If a class 1 diagnostics error occurs, the content of this parameter at this point of time is stored at the first place in the **P-0-0193, Error memory operating hours of control section** parameter.

**Note:** The value is displayed in seconds and is stored on the control section!

See also Functional Description "Operating Hours Counter"

### P-0-0191, Operating hours power section

	Input min/max:	Default value:	Unit:
MPB:	--- / ---	---	s

**Function** This parameter displays the operating hours of the power section since the delivery of the device. These operating hours are the time during which the drive has been operated with drive enable switched on.

**Note:** The value is displayed in seconds and is stored on the power section!

See also Functional Description "Operating Hours Counter"

**P-0-0192, Error memory of diagnostic numbers**

	Input min/max:	Default value:	Unit:
<b>MPB:</b>	--- / ---	---	--

**Function** When the drive diagnoses a class 1 diagnostics error, a bit is set in parameter **S-0-0011, Class 1 diagnostics**. Bit 13 for "Error in class 1 diagnostics" is then set in the drive status word.

See also Functional Description "Error Memory (Power Section and Control Section)"

**P-0-0193, Error memory operating hours of control section**

	Input min/max:	Default value:	Unit:
<b>MPB:</b>	--- / ---	---	s

**Function** When the drive diagnoses a class 1 diagnostics error, a bit is set in parameter **S-0-0011, Class 1 diagnostics**. Bit 13 for "Error in class 1 diagnostics" is then set in the drive status word.

See also Functional Description "Error Memory (Power Section and Control Section)"

**P-0-0194, Error memory power section**

	Input min/max:	Default value:	Unit:
<b>MPB:</b>	0 / 4294967295	---	--

**Function** When the drive diagnoses a class 1 diagnostics error, a bit is set in parameter **S-0-0011, Class 1 diagnostics**. Bit 13 for "Error in class 1 diagnostics" is then set in the drive status word.

See also Functional Description "Error Memory (Power Section and Control Section)"

**P-0-0196, Build date and time**

	Input min/max:	Default value:	Unit:
<b>MPB:</b>	--- / ---	---	--

**Function** The build date and build time of the drive firmware can be read from this parameter as a text.

See also Functional Description "System Overview"

**P-0-0197, System time**

	Input min/max:	Default value:	Unit:
<b>MPB:</b>	--- / ---	---	--

**Function** Parameter P-0-0197 contains a system time of the drive with a resolution of 100 ns. It can be used in conjunction with the parameters P-0-0198 and



P-0-0199 to establish an axis-comprehensive time reference in the case of error.

---

**Note:** In the case of drive errors, the drive stores the system time in parameter **P-0-0198, System time error memory**.

---

See also Functional Description "Diagnostic and Service Functions"  
 See also Parameter Description "P-0-0198, System time error memory"  
 See also Parameter Description "P-0-0199, System time error code"

### P-0-0198, System time error memory

	Input min/max:	Default value:	Unit:
<b>MPB:</b>	--- / ---	---	--

**Function** The count of parameter **P-0-0197, System time** at the time the error is detected is stored in parameter **P-0-0198, System time error memory**. It can be used in conjunction with the parameters P-0-0197 and P-0-0199 to establish an axis-comprehensive time reference in the case of error.

---

**Note:** P-0-0198 is stored together with P-0-0199 as customer data; in this way the system time error memory and the system time error code remain in the system when parameter download takes place via the master communication or the serial interface or the MMC.

---

See also Functional Description "Diagnostic and Service Functions"  
 See also Parameter Description "P-0-0197, System time"  
 See also Parameter Description "P-0-0199, System time error code"

### P-0-0199, System time error code

	Input min/max:	Default value:	Unit:
<b>MPB:</b>	--- / ---	---	--

**Function** Parameter P-0-0199 contains the error code consistent with **P-0-0197, System time**. It can be used in conjunction with the parameters P-0-0197 and P-0-0198 to establish an axis-comprehensive time reference in the case of error.

### P-0-0208, Analog input 5

	Input min/max:	Default value:	Unit:
<b>MPB:</b>	--- / ---	---	V

**Function** The input voltage currently provided at the analog input 5 can be read and displayed in Volt by means of this parameter.

---

**Note:** Analog input 5 is only available in conjunction with a double-axis device with configuration of 2 optional cards MA1!

---

See also Functional Description "Analog Interface"  
 See also Functional Description "Analog Inputs"

**P-0-0209, Analog input 6**

	Input min/max:	Default value:	Unit:
MPB:	--- / ---	---	V

**Function** The input voltage currently provided at the analog input 6 can be read and displayed in Volt by means of this parameter.

---

**Note:** Analog input 6 is only available in conjunction with a double-axis device with configuration of 2 optional cards MA1!

---

See also Functional Description "Analog Interface"

See also Functional Description "Analog Inputs"

**P-0-0210, Analog input 1**

	Input min/max:	Default value:	Unit:
MPB:	--- / ---	---	V

**Function** The input voltage currently provided at the analog input 1 can be read and displayed in Volt by means of this parameter.

See also Functional Description "Analog Interface"

See also Functional Description "Analog Inputs"

**P-0-0211, Analog input 2**

	Input min/max:	Default value:	Unit:
MPB:	--- / ---	---	V

**Function** The input voltage currently provided at the analog input 2 can be read and displayed in volt by means of this parameter.

See also Functional Description "Analog Interface"

See also Functional Description "Analog Inputs"

**P-0-0212, Analog input, list of assignable parameters**

	Input min/max:	Default value:	Unit:
MPB:	--- / ---	---	--

**Function** This list parameter contains the IDNs of the parameters that can be entered in **P-0-0213, Analog input, assignment A, target parameter** and **P-0-0236, Analog input, assignment B, target parameter**. These parameters are available for assigning an analog input value.

See also Functional Description "Analog Interface"

See also Functional Description "Analog Inputs"

**P-0-0213, Analog input, assignment A, target parameter**

	Input min/max:	Default value:	Unit:
--	----------------	----------------	-------



See also Functional Description "Analog Inputs"

### P-0-0217, Analog input 1, time constant input filter

	Input min/max:	Default value:	Unit:
MPB:	0,250 / 60,000	0,250	ms

**Function** The analog input 1 can be read by the drive firmware via a digital low-pass filter. The limit frequency of this filter is set by this parameter, if necessary the filter can also be deactivated.

$$f_{\text{limit}} = 1000 / (2 * \pi * T_{\text{input}})$$

$f_{\text{limit}}$ : limit frequency in Hz  
 $T_{\text{input}}$ : time constant of input filter in ms

Fig. 7-43: Calculating the limit frequency of the analog input filter

Performance (P-0-0556)	Input filter	$T_{\text{input}}$ in $\mu\text{s}$
standard (bit 2 = 0)	inactive	500 $\mu\text{s}$
	active	>500 $\mu\text{s}$
high (bit 2 = 1)	inactive	250 $\mu\text{s}$
	active	>250 $\mu\text{s}$

Fig. 7-44: Settings of the analog input filter

See also Functional Description "Analog Interface"

See also Functional Description "Analog Inputs"

### P-0-0218, Analog input, control parameter

	Input min/max:	Default value:	Unit:
MPB:	--- / ---	0	--

**Function** This parameter is used

- for controlling the command "analog input adjust"
- for assigning the analog channels for "assignment analog channel A" or "assignment analog channel B"
- for selecting current input or voltage input
- for selecting the measuring range
- for selecting the kind of reaction in the case of wire break

**Note:** It is possible to adjust both analog voltage and current inputs!

See also Functional Description "Analog Interface"

See also Functional Description "Analog Inputs"

### P-0-0219, Analog input, maximum value for adjust

	Input min/max:	Default value:	Unit:
MPB:	--- / ---	0	--

- Function** This parameter makes available a defined command value for determining the values of
- P-0-0214, Analog input, assignment A, scaling per 10V full scale or
  - P-0-0237, Analog input, assignment B, scaling per 10V full scale

See also Functional Description "Analog Interface"

See also Functional Description "Analog Inputs"

### P-0-0220, C2800 Analog input adjust command

	Input min/max:	Default value:	Unit:
<b>MPB:</b>	--- / ---	---	--

- Function** By means of this command, together with
- P-0-0218, Analog input, control parameter
  - P-0-0219, Analog input, maximum value for adjust
- it is possible to carry out a zero point and gain adjust for the respective selected analog input (cf. P-0-0218).

See also Functional Description "Analog Interface"

See also Functional Description "Analog Inputs"

### P-0-0222, Travel range limit switch inputs

	Input min/max:	Default value:	Unit:
<b>MPB:</b>	--- / ---	0	--

- Function** In this parameter the signals of the travel range limit switch inputs are displayed. It is used to diagnose the travel range limit switch inputs.

See also Functional Description "Position Limitation/Travel Range Limit Switch"

### P-0-0223, E-Stop input

	Input min/max:	Default value:	Unit:
<b>MPB:</b>	--- / ---	---	--

- Function** The status of the E-Stop input is mapped to this parameter. The parameter can be used to check the E-Stop input or for visualization by a commissioning program.

See also Functional Description "E-Stop Function"

### P-0-0228, Analog input 3

	Input min/max:	Default value:	Unit:
<b>MPB:</b>	--- / ---	---	V

- Function** The input voltage currently provided at the analog input 3 can be read and displayed in Volt by means of this parameter.

See also Functional Description "Analog Interface"

See also Functional Description "Analog Inputs"

### P-0-0229, Analog input 4

	Input min/max:	Default value:	Unit:
MPB:	--- / ---	---	V

**Function** The input voltage currently provided at the analog input 4 can be read and displayed in Volt by means of this parameter.

See also Functional Description "Analog Interface"

See also Functional Description "Analog Inputs"

### P-0-0231, Analog input 2, time constant input filter

	Input min/max:	Default value:	Unit:
MPB:	0,250 / 60,000	0,250	ms

**Function** The analog input 2 can be read by the drive firmware via a digital low-pass filter. The limit frequency of this filter is set by this parameter, if necessary the filter can also be deactivated.

$$f_{\text{grenz}} = 1000 / (2 * \pi * T_{\text{Eing.}})$$

$f_{\text{grenz}}$ : limit frequency in Hz

$T_{\text{Eing.}}$ : time constant of input filter in ms

Fig. 7-45: Calculating the limit frequency of the analog input filter

See also Functional Description "Analog Interface"

See also Functional Description "Analog Inputs"

### P-0-0232, Analog input 3, time constant input filter

	Input min/max:	Default value:	Unit:
MPB:	0,250 / 60,000	0,250	ms

**Function** The analog input 3 can be read by the drive firmware via a digital low-pass filter. The limit frequency of this filter is set by this parameter, if necessary the filter can also be deactivated.

$$f_{\text{limit}} = 1000 / (2 * \pi * T_{\text{input}})$$

$f_{\text{limit}}$ : limit frequency in Hz

$T_{\text{input}}$ : time constant of input filter in ms

Fig. 7-46: Calculating the limit frequency of the analog input filter

See also Functional Description "Analog Interface"

See also Functional Description "Analog Inputs"

### P-0-0233, Analog input 4, time constant input filter

	Input min/max:	Default value:	Unit:
MPB:	0,250 / 60,000	0,250	ms

**Function** The analog input can be uploaded/downloaded by the drive firmware via a digital low-pass filter. The limit frequency of this filter is set by this parameter, if necessary the filter can also be deactivated.

$$f_{\text{grenz}} = 1000 / (2 * \pi * T_{\text{Eing.}})$$

$f_{\text{limit}}$ : limit frequency in Hz

$T_{\text{input}}$ : time constant of input filter in ms

Fig. 7-47: Calculating the limit frequency of the analog input filter

See also Functional Description "Analog Interface"

See also Functional Description "Analog Inputs"

### P-0-0234, Analog input 5, time constant input filter

	Input min/max:	Default value:	Unit:
<b>MPB:</b>	0,250 / 60,000	0,250	ms

**Function** The analog input 5 can be read by the drive firmware via a digital low-pass filter.

---

**Note:** Analog input 5 is only available in conjunction with a double-axis device with configuration of 2 optional cards MA1!

---

See also Functional Description "Performance Data"

See also Functional Description "Analog Interface"

See also Functional Description "Analog Inputs"

### P-0-0235, Analog input 6, time constant input filter

	Input min/max:	Default value:	Unit:
<b>MPB:</b>	0,250 / 60,000	0,250	ms

**Function** The analog input 6 can be read by the drive firmware via a digital low-pass filter.

---

**Note:** Analog input 6 is only available in conjunction with a double-axis device with configuration of 2 optional cards MA1!

---

See also Functional Description "Performance Data"

See also Functional Description "Analog Interface"

See also Functional Description "Analog Inputs"

### P-0-0236, Analog input, assignment B, target parameter

	Input min/max:	Default value:	Unit:
<b>MPB:</b>	--- / ---	0	--

**Function** In this parameter the IDN of that parameter is entered to which a value corresponding to the voltage at the respective analog input is to be written. The scaling is made via **P-0-0237, Analog input, assignment A, scaling per 10V full scale!**

**Note:** Only such IDNs can be entered in **P-0-0213** that are contained in **P-0-0212, Analog input, list of assignable parameters**.

See also Functional Description "Analog Interface"

See also Functional Description "Analog Inputs"

### **P-0-0237, Analog input, assignment B, scaling per 10V full scale**

	<b>Input min/max:</b>	<b>Default value:</b>	<b>Unit:</b>
<b>MPB:</b>	--- / ---	0	--

**Function** By means of this parameter the analog input for assignment B (range of values per 10 V) is scaled.

Unit, decimal places and data type are determined by the parameter assigned in **P-0-0236, Analog input, assignment B, target parameter**.

See also Functional Description "Analog Interface"

See also Functional Description "Analog Inputs"

### **P-0-0238, Analog input, assignment B, signal value at 0V**

	<b>Input min/max:</b>	<b>Default value:</b>	<b>Unit:</b>
<b>MPB:</b>	--- / ---	0	--

**Function** In this parameter the reference of the analog input for assignment B (value with a voltage of 0 V at the analog input) is defined. This allows compensating a possible offset of the voltage at the analog input.

Unit, decimal places and data type are determined by the parameter assigned in **P-0-0236, Analog input, assignment B, target parameter**.

See also Functional Description "Analog Interface"

See also Functional Description "Analog Inputs"

### **P-0-0239, Analog input, assignment B, dead zone**

	<b>Input min/max:</b>	<b>Default value:</b>	<b>Unit:</b>
<b>MPB:</b>	0,000 / 10,000	0,000	V

**Function** By means of this parameter it is possible to define a range of values for the analog input voltage (assignment B). The controller interprets this range of values as voltage value 0 V ("dead zone").

### **P-0-0300, Digital I/Os, assignment list**

	<b>Input min/max:</b>	<b>Default value:</b>	<b>Unit:</b>
<b>MPB:</b>	--- / ---	---	--

**Function** Via parameter P-0-0300 drive signals are assigned to the digital inputs/outputs of the control section by configuring the corresponding IDN in the list parameter.



---

**Note:** Apart from the IDN, the bit number desired for the input or output (cf. **P-0-0301, Digital I/Os, bit numbers**) and the output direction (cf. **P-0-0302, Digital I/Os, direction**) have to be defined!

---

See also Functional Description "Digital Inputs/Outputs"

### P-0-0301, Digital I/Os, bit numbers

	Input min/max:	Default value:	Unit:
<b>MPB:</b>	--- / ---	---	--

**Function** This parameter is used to configure the digital inputs/outputs of the control section.

In **P-0-0301, Digital I/Os, bit numbers** the desired bit number which is to be assigned to the digital input or output is indicated for each assigned parameter (cf. **P-0-0300, Digital I/Os, assignment list**).

---

**Note:** Apart from determining the bit number, the IDN desired for the output or input has to be defined via **P-0-0300, Digital I/Os, assignment list**.

---

See also Parameter Description "P-0-0300, Digital I/Os, assignment list"

See also Functional Description "Digital Inputs/Outputs"

### P-0-0302, Digital I/Os, direction

	Input min/max:	Default value:	Unit:
<b>MPB:</b>	--- / ---	---	--

**Function** This parameter is used to configure the digital inputs/outputs of the control section.

In parameter **P-0-0302, Digital I/Os, direction** the desired function (direction) is indicated for each assigned parameter (cf. **P-0-0300, Digital I/Os, assignment list**). This means that parameter P-0-0302 sets the digital input or output.

- "0" for "input" function
- "1" for "output" function

---

**Note:** Apart from determining the "digital I/Os, direction", the desired IDN and bit number for the output or input has to be defined via **P-0-0300, Digital I/Os, assignment list** or **P-0-0301, Digital I/Os, bit numbers**.

---

See also Functional Description "Digital Inputs/Outputs"

### P-0-0303, Digital I/Os, status display

	Input min/max:	Default value:	Unit:
<b>MPB:</b>	--- / ---	---	--

**Function** This parameter displays the current states of the digital inputs. This means that the current signal level or switch status (only for MP\*02VRS!) is displayed.

The table below illustrates the different significance of the individual bits depending on control section and firmware:

### P-0-0304, Digital I/Os, outputs

	Input min/max:	Default value:	Unit:
<b>MPB:</b>	--- / ---	---	--

**Function** This parameter displays the states of the digital outputs and relay outputs. This means that the current signal level or switch status is displayed; the following cases have to be distinguished for inputs/outputs that can be switched:

- With configuration as output, the output signal status is displayed in P-0-0304.
- With configuration as input, the input signal status is displayed in **P-0-0303, Digital I/Os, inputs.**

---

**Note:** Configuration takes place via **P-0-0302, Digital I/Os, direction.**

---

See also Functional Description "Digital Inputs/Outputs"

### P-0-0414, Analog Output 3

	Input min/max:	Default value:	Unit:
<b>MPB:</b>	-10,000 / 10,000	0,000	V

**Function** This parameter indicates the voltage value that is output via the analog output 3 of the drive controller.

See also Functional Description "Analog Outputs"

### P-0-0415, Analog Output 4

	Input min/max:	Default value:	Unit:
<b>MPB:</b>	-10,000 / 10,000	0,000	V

**Function** This parameter indicates the voltage value that is output via the analog output 4 of the drive controller.

See also Functional Description "Analog Outputs"

### P-0-0416, Analog Output 5

	Input min/max:	Default value:	Unit:
<b>MPB:</b>	-10,000 / 10,000	0,000	V

**Function** This parameter displays the voltage value that is output via the analog output 5 of the drive controller.

---

**Note:** Analog output 5 is only available in conjunction with a double-axis device with configuration of 2 optional cards MA1!

---

See also Functional Description "Analog Outputs"

### P-0-0417, Analog Output 6

	Input min/max:	Default value:	Unit:
<b>MPB:</b>	-10,000 / 10,000	0,000	V

**Function** This parameter displays the voltage value that is output via the analog output 6 of the drive controller.

---

**Note:** Analog output 6 is only available in conjunction with a double-axis device with configuration of 2 optional cards MA1!

---

See also Functional Description "Analog Outputs"

### P-0-0418, Analog output, assignment A, signal value at 0V

	Input min/max:	Default value:	Unit:
<b>MPB:</b>	--- / ---	0	--

**Function** In this parameter the reference of the analog output of assignment A (value with an output of 0 V) is defined. The unit is determined by the parameter assigned in **P-0-0420, Analog output, assignment A, signal selection**.

When assigning parameters with the "binary" display attribute, the parameter is not active.

See also Functional Description "Analog Outputs"

### P-0-0419, Analog output, assignment B, signal value at 0V

	Input min/max:	Default value:	Unit:
<b>MPB:</b>	--- / ---	0	--

**Function** In this parameter the reference of the analog output of assignment B (value with an output of 0 V) is defined. The unit is determined by the parameter assigned in **P-0-0423, Analog output, assignment B, signal selection**.

When assigning parameters with the "binary" display attribute, the parameter is not active.

See also Functional Description "Analog Outputs"

### P-0-0420, Analog output, assignment A, signal selection

	Input min/max:	Default value:	Unit:
<b>MPB:</b>	--- / ---	---	--

**Function** By means of this parameter it is possible to assign a parameter IDN to the analog outputs 1 and 3 of the drive controller. The current parameter value is output as voltage at the analog output, if the mode of the analog output in **P-0-0427, Control parameter of analog output** has been set to output of assignment A. The output voltage can be made visible with an oscilloscope, for example.

It is only possible to assign those IDNs that have been entered in the **P-0-0426, Analog output IDN list of assignable parameters** list.

See also Functional Description "Analog Outputs"

### P-0-0422, Analog output, assignment A, scaling [1/V]

	Input min/max:	Default value:	Unit:
MPB:	--- / ---	0	--

**Function** This parameter is used to scale the voltage output by analog output 1 and 3. The unit is determined by the parameter assigned in **P-0-0420, Analog output, assignment A, signal selection**.

When assigning parameters with the "binary" display attribute, the number of the bit to be output at the analog output is defined in this parameter. When the respective bit has not been set, the output voltage is 0 V. When the bit has been set, 1 V is output.

See also Functional Description "Analog Outputs"

### P-0-0423, Analog output, assignment B, signal selection

	Input min/max:	Default value:	Unit:
MPB:	--- / ---	---	--

**Function** By means of this parameter it is possible to assign a parameter IDN to the analog outputs 2 and 4 of the drive controller. The current parameter value is output as voltage at the analog output, if the mode of the analog output in **P-0-0427, Control parameter of analog output** has been set to output of assignment B. The output voltage can be made visible with an oscilloscope, for example.

It is only possible to assign those IDNs that have been entered in the **P-0-0426, Analog output IDN list of assignable parameters** list.

See also Functional Description "Analog Outputs"

### P-0-0425, Analog output, assignment B, scaling [1/V]

	Input min/max:	Default value:	Unit:
MPB:	--- / ---	0	--

**Function** This parameter is used to scale the voltage output by analog output 2 and 4. The unit is determined by the parameter assigned in **P-0-0423, Analog output, assignment B, signal selection**.

When assigning parameters with the "binary" display attribute, the number of the bit to be output at the analog output is defined in this parameter. When the respective bit has not been set, the output voltage is 0 V. When the bit has been set, 1 V is output.

See also Functional Description "Analog Outputs"

### P-0-0426, Analog output IDN list of assignable parameters

	Input min/max:	Default value:	Unit:
MPB:	--- / ---	---	--

**Function** This parameter contains a list of all parameter IDNs that can be assigned via

- **P-0-0420, Analog output, assignment A, signal selection** and
- **P-0-0423, Analog output, assignment B, signal selection**

See also Functional Description "Analog Outputs"

### P-0-0427, Control parameter of analog output

	Input min/max:	Default value:	Unit:
MPB:	--- / ---	---	--

**Function** This configuration parameter determines the signal source and conditions for the analog outputs.

See also Functional Description "Analog Outputs"

### P-0-0440, Actual output current value (absolute value)

	Input min/max:	Default value:	Unit:
MPB:	--- / ---	---	A eff

**Function** Display parameter for the measured actual current value which is the rms value of the motor phase current.

The phase currents are scanned in the current controller cycle, converted as a current vector and the rms value is calculated from these data. This parameter displays the value averaged during 2 ms and is used as the input value for the overload models of amplifier and motor.

### P-0-0441, Overload warning

	Input min/max:	Default value:	Unit:
MPB:	0 / 100	80	%

**Function** Parameter for determining a threshold value for thermal controller work load.

If the value displayed in **P-0-0141, Thermal drive load** exceeds the determined threshold, the warning **E2061 Amplifier overload prewarning** is generated.

The unit of the threshold value corresponds to the one of P-0-0141 (%).

**Note:** When 100% is entered, **E2061 Amplifier overload prewarning** is not displayed. Instead, the warning **E8057 Amplifier overload, current limit active** is already generated with approx. 97% of the thermal work load.

**P-0-0442, Actual value torque limit positive (stationary)**

	Input min/max:	Default value:	Unit:
MPB:	--- / ---	---	S-0-0086

**Function** Display parameter for the effective positive torque limit value. The value displayed is the lowest value of

- **S-0-0092, Bipolar torque/force limit value**
- **P-0-0109, Torque/force peak limit**
- **S-0-0082, Torque/force limit value positive**
- work load-dependent limits by motor and controller
- motor depending limits.

**P-0-0443, Actual value torque limit negative (stationary)**

	Input min/max:	Default value:	Unit:
MPB:	--- / ---	---	S-0-0086

**Function** Display parameter for the effective negative torque limit value. The value displayed is the lowest value of

- **S-0-0092, Bipolar torque/force limit value**
- **P-0-0109, Torque/force peak limit**
- **S-0-0083, Torque/force limit value negative**
- work load-dependent limits by motor and controller
- motordepending limits.

See also Functional Description "Torque/Force Limitation"

**P-0-0444, Actual value peak torque limit**

	Input min/max:	Default value:	Unit:
MPB:	--- / ---	---	S-0-0086

**Function** Display parameter for the maximum drive torque or the maximum drive force. The value is the limit value for positive and negative torque/force command values.

The value displayed is the lower value of

- **P-0-0109, Torque/force peak limit**
- **S-0-0092, Bipolar torque/force limit value**
- work load-dependent limits by motor and controller
- motor-dependent limits.

The unit for the values of this parameter depends on the scaling that has been set (**S-0-0086, Torque/force data scaling type**).

See also Functional Description "Torque/Force Limitation"

**P-0-0445, Status word torque/current limit**

	Input min/max:	Default value:	Unit:
MPB:	--- / ---	---	--

**Function** This parameter contains the status messages (bits) for the torque/current limitation.

See also Functional Description "Torque/Force and Current Limitation"

**P-0-0512, Temperature sensor**

	Input min/max:	Default value:	Unit:
MPB:	0 / var.	1	--

**Function** The controller monitors the motor temperature by means of temperature sensors installed in the motor. The controller can directly evaluate standard temperature sensors because the characteristics of the sensors are stored in the firmware.

See also Functional Description "Motor Temperature Monitoring"

**P-0-0513, Temperature sensor characteristic**

	Input min/max:	Default value:	Unit:
MPB:	0 / 4294967295	---	Ohm

**Function** If a temperature sensor is to be evaluated the characteristic of which has not been stored in the firmware, the characteristic has to be entered in this parameter in the form of a value table.

See also Functional Description "Motor Temperature Monitoring"

**P-0-0525, Holding brake control word**

	Input min/max:	Default value:	Unit:
MPB:	--- / ---	0	--

**Function** By this parameter the controller is informed of the type of motor holding brake and the way it is controlled:

- self-releasing or self-holding brake
- main drive brake or servo brake
- automatic brake check when switching drive enable on and off
- enabling the "release holding brake" command

**Note:**

- For Rexroth motors with encoder data memory, MHD, MKD, MKE and MSK, bit 0 and bit 2 are automatically set!
- For motors without encoder data memory, bit 0 and bit 2, depending on whether a holding brake is available, have to be manually set to the appropriate value!
- For motors without integrated holding brake, an external holding brake can be controlled by the controller (set bit 2 to "1"). Set bit 0 according to type of holding brake!

See also Functional Description "Motor Holding Brake"

### P-0-0528, Flux control loop proportional gain

	Input min/max:	Default value:	Unit:
MPB:	0,00 / 100,00	1,00	--

**Function** For asynchronous motors, the gain of the flux loop is entered in this parameter.

See also Functional Description "Field-Oriented Closed-Loop Current Control"

### P-0-0529, Scaling of stall current limit

	Input min/max:	Default value:	Unit:
MPB:	10 / 150	100	%

**Function** The stall current limit is the limit for the torque-generating current of asynchronous motors.

See also Functional Description "Field-Oriented Closed-Loop Current Control"

### P-0-0530, Slip increase

	Input min/max:	Default value:	Unit:
MPB:	1,00 / 2,00	1,50	1/100K

**Function** This parameter is only used for asynchronous motors. In the asynchronous motor the rotor resistance and therefore the rotor time constant change as the temperature changes.

See also Functional Description "Field-Oriented Closed-Loop Current Control"

### P-0-0532, Premagnetization factor

	Input min/max:	Default value:	Unit:
MPB:	var. / var.	100	%

**Function** With this parameter it is possible to reduce the magnetizing current of an asynchronous motor and therefore the rotor flux. The factor is referring to **P-0-4004, Magnetizing current**.

See also Functional Description "Motor, Mechanical Axis System, Measuring Systems"

### P-0-0533, Voltage loop proportional gain

	Input min/max:	Default value:	Unit:
MPB:	0,000 / 4294967,295	0,500	A/V



**Function** By means of this parameter the proportional gain of the voltage loop is entered. The voltage loop is used to control the motor voltage in the field-weakening range.

---

**Note:**

Writing the correct value to this parameter:

- In the case of MAD and MAF with encoder data memory automatically during initial commissioning.
- In the case of 2AD, ADF, linear and rotary kit motors, by loading the motor parameters with the commissioning software (e.g. IndraWorks).
- In the case of other motors: default value or manual input.

---

See also Functional Description "Third-Party Motors at IndraDrive Controllers"

### P-0-0534, Voltage loop integral action time

	Input min/max:	Default value:	Unit:
<b>MPB:</b>	0,0 / 429496729,5	600,0	ms

**Function** By means of this parameter the integral action time of the voltage loop is entered. The voltage loop is used to control the motor voltage in the field-weakening range.

---

**Note:**

Writing the correct value to this parameter:

- In the case of MAD and MAF with encoder data memory automatically during initial commissioning.
- In the case of 2AD, ADF, linear and rotary kit motors, by loading the motor parameters with the commissioning software (e.g. IndraWorks).
- In the case of other motors: default value or manual input.

---

See also Functional Description "Determining the Motor Parameter Values"

### P-0-0535, Motor voltage at no load

	Input min/max:	Default value:	Unit:
<b>MPB:</b>	0,0 / 100,0	80,0	%

**Function** As a matter of principle, this parameter only takes effect in field weakening operation. It defines a voltage that is indicated in percent of the maximum converter output voltage.

See also Functional Description "Determining the Motor Parameter Values"

### P-0-0536, Maximum motor voltage

	Input min/max:	Default value:	Unit:
--	----------------	----------------	-------

**MPB:** 50,0 / 100,0 90,0 %

**Function** This parameter defines the command voltage of the voltage loop. It is indicated in percent of the maximum converter output voltage.

---

**Note:**

Writing the correct value to this parameter:

- In the case of MAD and MAF with encoder data memory automatically during initial commissioning.
  - In the case of 2AD, ADF, linear and rotary kit motors, by loading the motor parameters with the commissioning software (e.g. IndraWorks).
  - In the case of other motors: Default value or manual input, set a maximum of 90% because of the required control margin!
- 

See also Functional Description "Third-Party Motors at IndraDrive Controllers"

### P-0-0539, Holding brake status word

	Input min/max:	Default value:	Unit:
<b>MPB:</b>	--- / ---	---	--

**Function** This parameter displays the current status of the holding brake.

See also Functional Description "Motor Holding Brake"

### P-0-0542, C2000 Command Release motor holding brake

	Input min/max:	Default value:	Unit:
<b>MPB:</b>	--- / ---	---	--

**Function** By means of this parameter it is possible to release the motor holding brake when the drive enable has been switched off. At the start of the command the motor holding brake is released, when the command is terminated the brake is applied again.

If drive enable is set with the command being active, the holding brake remains released, when drive enable is switched off, the brake is automatically applied.

---

**Note:** The command has to be activated via bit 5 in **P-0-0525, Holding brake control word**.

---

See also Functional Description "Motor Holding Brake"

### P-0-0551, Current load torque

	Input min/max:	Default value:	Unit:
<b>MPB:</b>	--- / ---	---	S-0-0086

**Function** In this parameter, the maximum occurring load torque of the axis in standstill is displayed and cyclically compared to **P-0-0547, Nominal load**

**of holding system.** When **P-0-0547, Nominal load of holding system** is exceeded, the error message **F3116 Nominal load torque of holding system exceeded** is output.

### P-0-0555, Status word of axis controller

	Input min/max:	Default value:	Unit:
MPB:	--- / ---	---	--

**Function** This parameter contains the following status information (messages) regarding axis control in the form of individual status bits:

- velocity messages
- limits that have been reached, i.e. information regarding an active limitation

See also Functional Description "Limitations"

See also Functional Description "Axis Control"

### P-0-0556, Config word of axis controller

	Input min/max:	Default value:	Unit:
MPB:	--- / ---	32769	--

**Function** This parameter is used for configuring functions specific to axis control and setting the control performance.

See also Functional Description "Drive Control - Axis Control (Closed-Loop Operation)"

See also Functional Description "Performance Data"

### P-0-0568, Voltage boost

	Input min/max:	Default value:	Unit:
MPB:	0,00 / 50,00	0,00	V eff

**Function** By means of this parameter it is possible to increase the voltage at the base point of the U/f characteristic (in the case of standstill or very low speed of an asynchronous motor). The voltage required at the base point is determined on the basis of the motor data and provided by the controller.

### P-0-0569, Maximum stator frequency change

	Input min/max:	Default value:	Unit:
MPB:	0,01 / 3000,00	200,00	Hz/s

**Function** The maximum change of velocity with which the drive can follow the command values is determined by the motor and the sampling time of the stall protection loop. The limit value can be set with this parameter.

### P-0-0570, Stall protection loop proportional gain

	Input min/max:	Default value:	Unit:
MPB:	0,00 / 500,00	100,00	%

**Function** This parameter presets the P-gain of the stall protection loop.  
The enable signal of the stall protection loop is controlled via bit 12 in **P-0-0045, Control word of current controller**.

### P-0-0571, Stall protection loop integral action time

	Input min/max:	Default value:	Unit:
<b>MPB:</b>	0,0 / 6500,0	1,0	ms

**Function** By means of this parameter it is possible to set the integral action time of the stall protection loop.  
The enable signal of the stall protection loop is controlled via a bit in **P-0-0045, Control word of current controller**.

### P-0-0572, Slip compensation factor

	Input min/max:	Default value:	Unit:
<b>MPB:</b>	0,00 / 320,00	0,00	%

**Function** By means of this parameter it is possible to trim the slip compensation feedforward. With the setting 0.00% the feedforward is switched off completely.

### P-0-0573, IxR boost factor

	Input min/max:	Default value:	Unit:
<b>MPB:</b>	0,00 / 320,00	0,00	%

**Function** By means of this parameter it is possible to trim the feedforward of the IxR boost. With the setting 0.00% the feedforward is switched off completely.

### P-0-0574, Oscillation damping factor

	Input min/max:	Default value:	Unit:
<b>MPB:</b>	-320,00 / 320,00	0,00	%

**Function** By means of this parameter it is possible to trim the oscillation damping feedforward. With the setting 0.00% the feedforward is switched off completely.

### P-0-0575, Search mode: search current factor

	Input min/max:	Default value:	Unit:
<b>MPB:</b>	1,00 / 320,00	60,00	%

**Function** Via P-0-0045, Control word of current controller the search mode function can be selected. During the search process a search current is generated in the still turning machine that is to be searched.  
Search current = magnetizing current \* P-0-0575 / 100%

**P-0-0576, Search mode: finding point slip factor**

	Input min/max:	Default value:	Unit:
MPB:	-320,00 / 320,00	100,00	%

**Function** The search mode function is selected via **P-0-0045, Control word of current controller**. As soon as the machine has been found the rated slip is added to the speed at the "finding point". 100% are corresponding to the rated slip of the machine.

With clockwise rotating field:  $V = V_{\text{finding point}} + (V_{\text{slip}} * P-0-0576 / 100\%)$

With anti-clockwise rotat. field:  $V = V_{\text{finding point}} - (V_{\text{slip}} * P-0-0576 / 100\%)$

**P-0-0577, Square characteristic: lowering factor**

	Input min/max:	Default value:	Unit:
MPB:	0,00 / 100,00	50,00	%

**Function** The square characteristic is selected via **P-0-0045, Control word of current controller**. The degree of lowering in the basic range of setting is trimmed with this parameter.

The value of 100% corresponds to the original square curve. When the percentage value becomes lower, this lowering factor is reduced until the setting 0% has been reached which corresponds to the linear characteristic.

**P-0-0590, Motor model frequency loop proportional gain**

	Input min/max:	Default value:	Unit:
MPB:	0,00 / 655,35	10,00	%

**Function** This parameter only takes effect in conjunction with field-oriented current control without encoder. Together with **P-0-0591, Motor model frequency loop integral action time**, parameter P-0-0590 is used to parameterize the "frequency loop".

By means of the differences between motor model and measured currents, the frequency loop determines the current rotational frequency of the motor shaft. The output of the frequency loop supplies parameter **S-0-0040, Velocity feedback value** and is transmitted according to the velocity loop.

---

**Note:** Field-oriented current control without encoder is activated via **P-0-0045, Control word of current controller**. If the functional package "closed-loop" is active, "operation without encoder" has to be set in **P-0-0074, Encoder type 1 (motor encoder)**!

---

See also Functional Description "Field-Oriented Current Control"

See also Functional Description "Automatic Setting of Motor Control Parameters"

**P-0-0591, Motor model frequency loop integral action time**

	Input min/max:	Default value:	Unit:
MPB:	0,0 / 100,0	5,0	ms

**Function** This parameter only takes effect in conjunction with field-oriented current control without encoder. Together with **P-0-0590, Motor model frequency loop proportional gain**, parameter P-0-0591 is used to parameterize the "frequency loop".

By means of the differences between motor model and measured currents, the frequency loop determines the current rotational frequency of the motor shaft. The output of the frequency loop supplies parameter **S-0-0040, Velocity feedback value** and is transmitted according to the velocity loop.

---

**Note:** Field-oriented current control without encoder is activated via **P-0-0045, Control word of current controller**. If the functional package "closed-loop" is active, "operation without encoder" has to be set in **P-0-0074, Encoder type 1 (motor encoder)!**

---

See also Functional Description "Field-Oriented Current Control"

See also Functional Description "Automatic Setting of Motor Control Parameters"

### P-0-0592, Motor model adjust factor

	Input min/max:	Default value:	Unit:
<b>MPB:</b>	0,000 / 1,000	0,100	--

**Function** This parameter only takes effect in conjunction with field-oriented current control without encoder.

The drive-internal motor model calculation carried out in the current loop clock is corrected by means of the adjust factor entered in P-0-0592 so that the motor currents determined by means of the motor model and the rotor flux comply with the real values.

---

**Note:** Field-oriented current control without encoder is activated via **P-0-0045, Control word of current controller**. If the functional package "closed-loop" is active, "operation without encoder" has to be set in **P-0-0074, Encoder type 1 (motor encoder)!**

---

See also Functional Description "Field-Oriented Current Control"

See also Functional Description "Automatic Setting of Motor Control Parameters"

### P-0-0640, Cooling type

	Input min/max:	Default value:	Unit:
<b>MPB:</b>	0 / 4	0	--

**Function** The motors of the MSK, MHD and MKD series can be operated in different cooling types. Depending on the motor type, cooling can be realized as

- standard cooling (natural convection, non-ventilated)
- surface ventilation
- liquid cooling

- improved nat. cooling
- reduced nat. cooling

See also Functional Description "Motor, Mechanical Axis System, Measuring Systems" and "Current and Torque Limitation (Closed-Loop)"

## P-0-0690 – P-0-0899 (Synchronization Mode)

### P-0-0690, Additive velocity command value, process loop

	Input min/max:	Default value:	Unit:
MPB:		0	S-0-0044

**Function** In addition to S-0-0037, parameter P-0-0690 is used to set an additive velocity command value.

**Note:** P-0-0690 can preferably be used for drive-based process loops (by means of MLD)!

### P-0-0806, Current mains voltage crest value

	Input min/max:	Default value:	Unit:
MPB:	--- / ---	---	V

**Function** This parameter for HCS03 devices (converters) displays the current crest value of the mains voltage.

### P-0-0810, Minimum mains crest value

	Input min/max:	Default value:	Unit:
MPB:	0 / 780	---	V

**Function** For HCS converters, in this parameter it is possible to set an individual minimum value for the crest value of the mains voltage. The value is only effective, if it is greater than the minimum value of the mains connection voltage range!

#### For HCS02

If the mains crest value, when the converter is switched on, is lower than the value in P-0-0810, the diagnostic message **E2814 Undervoltage in mains** is generated.

#### For HCS03

If the mains crest value, when the converter is switched on or is in operation, is lower than the value in P-0-0810, the diagnostic message **E2814 Undervoltage in mains** is generated.

**Note:** The mains voltage crest value detected when switching on, for HCS devices is displayed in **P-0-0815, Nominal mains voltage crest value!**

**P-0-0815, Nominal mains voltage crest value**

	Input min/max:	Default value:	Unit:
MPB:	--- / ---	---	V

**Function** This parameter for HCS converters displays the mains voltage crest value that was measured when the mains voltage was switched in the first time. From this value the standard value for the undervoltage threshold (P-0-0114), the standard minimum value of the mains voltage crest value (P-0-0810) and the standard switch-on threshold of a braking resistor (P-0-0858) are derived.

**P-0-0819, Energy counter**

	Input min/max:	Default value:	Unit:
MPB:	-20000000,00 / 20000000,00	0,00	kWh

**Function** This parameter displays the energy which was supplied to the drive. The energy is determined by means of the operating time as the sum of the effective power.

**P-0-0833, Braking resistor threshold**

	Input min/max:	Default value:	Unit:
MPB:	--- / ---	---	V

**Function** The braking resistor is only switched on via the firmware if this is required for braking. This means that it is switched on whenever the DC bus voltage is higher than the voltage threshold **P-0-0833, Braking resistor threshold**.

**P-0-0844, Braking resistor load**

	Input min/max:	Default value:	Unit:
MPB:	--- / ---	---	%

**Function** This parameter indicates the thermal energy in percent, in relation to its maximum allowed energy content, currently stored in the braking resistor.

**P-0-0858, Data of external braking resistor**

	Input min/max:	Default value:	Unit:
MPB:	--- / ---	---	--

**Function** For HCS02/HCS03 converters the type data of an externally connected braking resistor are entered in this list parameter.

---

**Note:** For HCS03 devices there is only an optional external braking resistor available!

---

See also Functional Description "Power Supply"



**P-0-0859, Data of internal braking resistor**

	Input min/max:	Default value:	Unit:
MPB:	--- / ---	---	--

**Function** For converters the type data of the device-internal braking resistor are displayed in this list parameter. The parameter is stored in non-volatile form in the power section.

**P-0-0860, Converter configuration**

	Input min/max:	Default value:	Unit:
MPB:	--- / ---	---	--

**Function** In this parameter basic settings are made especially for converters. Parameter P-0-0860 is specifically used for configuring the power section of converters (HCS02.1, HCS03.1,...).

See also Functional Description "Power Supply"

**P-0-0861, Power supply status word**

	Input min/max:	Default value:	Unit:
MPB:	--- / ---	---	--

**Function** This parameter is used for status display of the power supply.

See also Functional Description "Power Supply"

**P-0-1100 – P-0-1299 (Velocity Control)****P-0-1120, Velocity control loop filter: filter type**

	Input min/max:	Default value:	Unit:
MPB:	0 / 8	---	--

**Function** This parameter allows activating and selecting up to 4 different filters (2<sup>nd</sup> order).

See also Functional Description "Velocity Loop"

**P-0-1121, Velocity control loop filter: limit frequency of low pass**

	Input min/max:	Default value:	Unit:
MPB:	4,0 / 4000,0	---	Hz

**Function** This parameter is used to parameterize the corner frequency of the 4 filters that can be selectively activated via P-0-1120. The input value is in Hz, i.e. the actual frequency ( $f=1/T$ ) is input at which it is intended to obtain an attenuation of  $-3\text{dB}$  (attenuation of the amplitude to 0.707 of the input amplitude!).

See also Functional Description "Velocity Loop"

### P-0-1122, Velocity control loop filter: bandwidth of band-stop filter

	Input min/max:	Default value:	Unit:
MPB:	10,0 / 1000,0	---	Hz

**Function** This parameter is used to parameterize the bandwidth of the 4 band-stop filters that can be selectively activated via P-0-1120 [n] = 2. The input value is in Hz, i.e. the actual frequency ( $f=1/T$ ) is input. Notes on how to parameterize the band-stop filter are contained in the Functional Description.

See also Functional Description "Velocity Loop"

### P-0-1123, Vel. cont. loop filter: center frequency of band-stop filter

	Input min/max:	Default value:	Unit:
MPB:	4,0 / 4000,0	---	Hz

**Function** This parameter is used to parameterize the center frequency of the 4 band-stop filters that can be selectively activated via P-0-1120 [n] = 2. The input value is in Hz, i.e. the actual frequency ( $f=1/T$ ) is input. Notes on how to parameterize the band-stop filter are contained in the Functional Description.

See also Functional Description "Velocity Loop"

### P-0-1125, Velocity control loop: average value filter clock

	Input min/max:	Default value:	Unit:
MPB:	1 / 16	1	--

**Function** This parameter allows filtering the velocity control loop deviation with a moving average filter. In the case of this filter type and with constant input value, the output is always:

$$\Delta Y = \frac{X}{M}$$

This means that the filter output, with constant input value, increases in a linear way and has reached its final value at the filter output after the time  $t = M \cdot T_A$ .

**Note:** This filter type therefore does not show the typical "creep behavior" (filter output increases and decreases according to an **e-function!**) of the usual VZ1 and VZ2 filters.

See also Functional Description "Velocity Loop"

### P-0-1126, Velocity control loop: acceleration feedforward

	Input min/max:	Default value:	Unit:
MPB:	0,0000 / 214748,3647	0,0000	P-0-4014

**Function** This parameter is used for activating and setting a variable acceleration feedforward in the "velocity control" mode.

See also Functional Description "Velocity Loop"

See also Functional Description "Position Loop (with Respective Feedforward Functions)"

### P-0-1150, Command value generator output

	Input min/max:	Default value:	Unit:
MPB:	--- / ---	---	--

**Function** This parameter displays the output value of the command value generator. The output value is displayed in the format of the assigned parameter.

### P-0-1151, Command value generator, list of possible target parameters

	Input min/max:	Default value:	Unit:
MPB:	--- / ---	---	--

**Function** This list parameter contains the IDNs of the parameters that can be entered in **P-0-1152, Command value generator, target parameter assignment**. These parameters are available for assigning the command value generator command value.

### P-0-1152, Command value generator, target parameter assignment

	Input min/max:	Default value:	Unit:
MPB:	--- / ---	0	--

**Function** In this parameter the IDN of that parameter is entered to which the result of the command value generator is to be written.

### P-0-1153, Command value generator, control word

	Input min/max:	Default value:	Unit:
MPB:	--- / ---	0	--

**Function** This parameter is used for configuring the integrated command value generator and provides the following possible settings.

See also Functional Description "Drive-Integrated Command Value Generator"

### P-0-1154, Command value generator, offset

	Input min/max:	Default value:	Unit:
MPB:	-214748,3647 / 214748,3647	0,0000	--

**Function** This parameter is used for setting the direct component (offset) for the selected signal (sine, square-wave, noise). The display, i.e. unit and scaling of the parameter, are set according to the assigned parameter.

### P-0-1155, Command value generator, amplitude

	Input min/max:	Default value:	Unit:
MPB:	0,0001 / 214748,3647	10,0000	--

**Function** This parameter is used for setting the amplitude (double crest value, peak-to-peak value). The range of values of the selected signal shape (sine, square-wave, noise) is between half the plus/minus amplitude. The display, i.e. unit and scaling of the parameter, are set according to the assigned parameter.

### P-0-1156, Command value generator, duration 1

	Input min/max:	Default value:	Unit:
MPB:	0,000 / 4294967,295	0,000	s

**Function** This parameter is used for setting the square-wave signal. For the duration **P-0-1156, Command value generator, duration 1** the command value generator output **P-0-1150, Command value generator, command value** is set to half the positive amplitude **P-0-1155, Command value generator, amplitude** plus offset **P-0-1154, Command value generator, offset**.

When the duration 1 is over, the output of the command value generator is set to half the negative amplitude **P-0-1155, Command value generator, amplitude** plus offset **P-0-1154, Command value generator, offset**. Duration 2 starts as of this point of time.

### P-0-1157, Command value generator, duration 2

	Input min/max:	Default value:	Unit:
MPB:	0,000 / 4294967,295	0,000	s

**Function** This parameter is used for setting the square-wave signal for command value generator.

When duration 1 is over, duration 2 starts. For this duration **P-0-1157, Command value generator, duration 2** the command value generator output **P-0-1150, Command value generator, command value** is set to half the negative amplitude **P-0-1155, Command value generator, amplitude** plus offset **P-0-1154, Command value generator, offset**. When duration 2 is over, the output signal is set to the offset **P-0-1154, Command value generator, offset** until the periodic time has been reached.

### P-0-1200, Control word 1 velocity control

	Input min/max:	Default value:	Unit:
MPB:	0 / 0x3FF	0	--

**Function** In the "velocity control" mode this parameter is used to control or configure the following functions:

- channel for velocity command value input (memory of fixed values or S-0-0036)
- behavior of ramp generator (run-up stop)
- command value generator (motor potentiometer)

---

**Note:** The control word can be cyclically written, the assignment of individual bits from signal control word or digital inputs is possible, too. In contrast to P-0-1214, parameter P-0-1200 is stored in the drive in volatile form!

---

See also Functional Description "Operating Mode: Velocity Control/Motor Potentiometer"

### P-0-1201, Ramp 1 pitch

	Input min/max:	Default value:	Unit:
<b>MPB:</b>		0	S-0-0160

**Function** The acceleration entered in **P-0-1201, Ramp 1 pitch** takes effect in the "velocity control" mode during acceleration.

See also Functional Description "Operating Modes - Velocity Control"

### P-0-1202, Final speed ramp 1

	Input min/max:	Default value:	Unit:
<b>MPB:</b>		0	S-0-0044

**Function** The parameter **P-0-1202, Final speed ramp 1** takes effect in the "velocity control" mode during acceleration and deceleration.

When exceeding (acceleration) or falling below (deceleration) the velocity indicated in **P-0-1202, Final speed ramp 1**, the pitch of the drive-internal speed command value ramp changes as follows:

- from the value indicated in **P-0-1201, Ramp 1 pitch** to the value indicated in **P-0-1203, Ramp 2 pitch** (acceleration)
- or from the value indicated in **P-0-1211, Deceleration ramp 1** to the value indicated in **P-0-1213, Deceleration ramp 2** (deceleration).

See also Functional Description "Velocity Command Value Reset with Filter and Ramp (Quick Stop)"

### P-0-1203, Ramp 2 pitch

	Input min/max:	Default value:	Unit:
<b>MPB:</b>		0	S-0-0160

**Function** The acceleration entered in **P-0-1203, Ramp 2 pitch** takes effect in the "velocity control" mode during acceleration.

With the acceleration entered in this parameter, the acceleration takes place from the last effective command value to the new preset command value as soon as the velocity at the ramp output is greater than the value entered in **P-0-1202, Final speed ramp 1**.

Influence of P-0-1209

If the function "speed masking in command value channel" is used (P-0-1207, P-0-1208, P-0-1209), the content of P-0-1201 is multiplied with the content of P-0-1209 and this influences the effective acceleration.

---

**Note:** If the value in parameter **P-0-1203, Ramp 2 pitch** = 0, the ramp 2 is not active.

---

See also Functional Description "Velocity Control Mode"

### P-0-1206, Memory of velocity command values

	Input min/max:	Default value:	Unit:
<b>MPB:</b>		---	S-0-0044

**Function** This list parameter is used as a memory of fixed command values for velocity command values. The individual values can be selected via the control word P-0-1200.

---

**Note:** As of MP\*04VRS, selection via P-0-1200 takes place in binarily coded form!

---

See also Functional Description "Operating Modes - Velocity Control"

See also Parameter Description "P-0-1200, Control word 1 velocity control"

### P-0-1207, Lower limit of velocity masking window

	Input min/max:	Default value:	Unit:
<b>MPB:</b>		---	S-0-0044

**Function** The list parameter "P-0-1207", in conjunction with the parameter "P-0-1208" (upper limit of velocity masking window), defines four velocity ranges (velocity windows).

The ranges apply to positive and negative velocities, the definitions of the ranges are mirrored with regard to speed zero.

---

**Note:**

- The function "velocity masking window" is only effective in the "velocity control" mode.
  - The parameter "P-0-1210, Status word of velocity control mode" contains information on the status of the current command value with regard to a velocity masking window.
- 

See also Functional Description "Velocity Loop"

### P-0-1208, Upper limit of velocity masking window

	Input min/max:	Default value:	Unit:
<b>MPB:</b>		---	S-0-0044

**Function** The list parameter "P-0-1208", in conjunction with the parameter "P-0-1207" (lower limit of velocity masking window), defines four velocity ranges (velocity windows).

The ranges apply to positive and negative velocities, the definitions of the ranges are mirrored with regard to speed zero.

---

**Note:**

- The function "velocity masking window" is only effective in the "velocity control" mode.
  - The parameter "P-0-1210, Status word of velocity control mode" contains information on the status of the current command value with regard to a velocity masking window.
- 

See also Functional Description "Velocity Loop"

### P-0-1209, Acceleration factors for velocity masking window

	Input min/max:	Default value:	Unit:
MPB:	1,00 / 100,00	---	--

**Function** The list parameter P-0-1209 contains the acceleration factors that take effect in the velocity ranges defined with P-0-1207 and P-0-1208.

The ramp generator passes the range of the velocity window (P-0-1207 and P-0-1208). But the acceleration factors indicated in P-0-1209 have a multiplying effect on the acceleration and deceleration values or, in the case of alternative scaling of the acceleration, on the ramp times of the ramp generator (P-0-1201, P-0-1203, P-0-1211 and P-0-1213).

See also Functional Description "Velocity Loop"

### P-0-1210, Status word of velocity control mode

	Input min/max:	Default value:	Unit:
MPB:	--- / ---	---	--

**Function** For the velocity control mode the parameter **P-0-1210** contains information on the current status of the ramp generator and the current command value.

---

**Note:** The parameter P-0-1210 can be configured in the cyclic actual value channel (e.g. AT with SERCOS) in **S-0-0144, Signal status word** and assigned to the digital outputs.

---

See also Functional Description "Velocity Loop"

### P-0-1211, Deceleration ramp 1

	Input min/max:	Default value:	Unit:
MPB:		0	S-0-0160

**Function** The deceleration entered in **P-0-1211, Deceleration ramp 1** only takes effect in the "velocity control" mode.

With the deceleration entered in this parameter, the deceleration takes place from the last effective velocity command value to the new velocity command value as soon as the velocity at the ramp output is smaller than the value in **P-0-1202, Final speed ramp 1**.

See also Functional Description "Velocity Command Value Reset with Filter and Ramp (Quick Stop)"

### P-0-1213, Deceleration ramp 2

	Input min/max:	Default value:	Unit:
<b>MPB:</b>		0	S-0-0160

**Function** The deceleration entered in **P-0-1213, Deceleration ramp 2** takes effect in the "velocity control" mode during the deceleration process.

With the deceleration entered in this parameter, the deceleration takes place from the last effective velocity command value to the new velocity command value as long as the velocity at the ramp output is greater than the value in **P-0-1202, Final speed ramp 1**.

See also Functional Description "Velocity Control Mode"

### P-0-1214, Control word 2 velocity control

	Input min/max:	Default value:	Unit:
<b>MPB:</b>	--- / ---	0	--

**Function** Via this parameter it is possible to influence, i.e. to control, the execution of a velocity control mode in the operating mode.

---

**Note:** P-0-0088 can be configured in the cyclic command value telegram!

---

See also Functional Description "Operating Modes - Velocity Control"

### P-0-1215, Motor potentiometer, acceleration

	Input min/max:	Default value:	Unit:
<b>MPB:</b>		100000	S-0-0160

**Function** In conjunction with the motor potentiometer available in the "velocity control" mode, this parameter is used for the following purposes:

- **For linear velocity change:**  
Definition of the velocity change by which the ramp velocity changes when setting P-0-1214, bit8 ("ramp+")  
→  $\Delta P-0-1218 = \text{activation time} * [P-0-1215]$
- **For square velocity change:**  
Definition of the acceleration change by which the ramp velocity changes within 2 s when setting P-0-1214, bit8 ("ramp+")  
→  $\Delta \text{acceleration} = \text{activation time} * ([P-0-1215] / 2 \text{ s})$

---

**Note:** With the input activated the velocity is increased in linear or square form (see **P-0-1214, Motor potentiometer, control**)



**parameter**) until the effective positive velocity limit value, i.e. minimum value (S-0-0091, S-0-0038), has been reached.

See also Functional Description "Operating Modes - Velocity Control"

### P-0-1216, Motor potentiometer, deceleration

	Input min/max:	Default value:	Unit:
<b>MPB:</b>		100000	S-0-0160

**Function** In conjunction with the motor potentiometer available in the "velocity control" mode, this parameter is used for the following purposes:

- **For linear velocity change:**  
definition of the velocity change by which the ramp velocity changes when setting P-0-1214, bit9 ("ramp-")  
→  $\Delta P-0-1218 = \text{activation time} * [P-0-1216]$
- **For square velocity change:**  
definition of the acceleration change by which the ramp velocity changes within 2s when setting P-0-1214, bit9 ("ramp-")  
→  $\Delta \text{deceleration} = \text{activation time} * ([P-0-1216] / 2s)$

**Note:** With the input activated the velocity is reduced in linear or square form (see **P-0-1214, Motor potentiometer, control parameter**) until the effective negative velocity limit value, i.e. minimum value (S-0-0091, S-0-0039), has been reached.

See also Functional Description "Operating Modes - Velocity Control"

### P-0-1217, Motor potentiometer, step size

	Input min/max:	Default value:	Unit:
<b>MPB:</b>		500000	S-0-0044

**Function** This parameter takes effect when bit 4 "change by constant velocity step" is one in **P-0-1214, Motor potentiometer, control parameter**.

**P-0-1218, Motor potentiometer, command value**, i.e. the velocity command value, is increased by the velocity value with every positive edge at the ramp input ramp+ until the positive velocity limit value S-0-0038 has been reached. With every negative edge at the ramp input ramp- it is reduced by the velocity value until the negative velocity limit value S-0-0039 has been reached.

See also Functional Description "Command Value Adjustment in Velocity Control"

### P-0-1218, Motor potentiometer, command value

	Input min/max:	Default value:	Unit:
<b>MPB:</b>	--- / ---	---	S-0-0044

**Function** Parameter **P-0-1218, Motor potentiometer, command value** is used to display the velocity command value generated by the motor

potentiometer. This value is then processed in the ramp generator and transmitted to **P-0-0048, Effective velocity command value**.

---

**Note:** The value of parameter P-0-1218 is stored in case the control voltage fails so that it is possible to reuse the value.

---

See also Functional Description "Operating Modes - Velocity Control"

### P-0-1222, Velocity command filter

	Input min/max:	Default value:	Unit:
<b>MPB:</b>	0 / 16	0	ms

**Function** This parameter is used to round acceleration jumps in the velocity command value characteristics in order to have a smooth initialization or deceleration of the drive in velocity control.

See also Functional Description "Velocity Command Value Reset with Filter and Ramp (Quick Stop)"

## P-0-1500 – P-0-1599 (General Device Parameters)

### P-0-1520, Control section type

	Input min/max:	Default value:	Unit:
<b>MPB:</b>	--- / ---	---	--

**Function** This parameter displays the type designation of the control section. By means of circuit board code parameters the controller firmware identifies all circuit boards incorporated in the control section and thus generates the type designation.

The type designation of the control section also implies firmware dependencies.

## P-0-2000 – P-0-2999 (General Device Parameters)

### P-0-2004, Active functional packages

	Input min/max:	Default value:	Unit:
<b>MPB:</b>	--- / ---	---	--

**Function** This parameter contains the active functional packages. When booting the functional packages selected in P-0-2003 are activated and then the respective bits are set or cleared in P-0-2004. This allows recognizing at any time which functional packages are actually active.

---

**Note:** This parameter can neither be written nor stored. It is for display only.

---

See also Functional Description "Enabling of Functional Packages"

See also Functional Description "Functional Packages"

## P-0-3600 – P-0-4095 (General Device Parameters)

### P-0-4004, Magnetizing current

	Input min/max:	Default value:	Unit:
MPB:	0,000 / var.	1,000	A eff

**Function** In the case of asynchronous motors, the nominal magnetizing current defined by Bosch Rexroth is entered in this parameter. The actually flowing magnetizing current in the base speed range results by multiplication of the value of P-0-4004 with **P-0-0532, Premagnetization factor**. In the field weakening range the magnetizing current, with increasing speed, is reduced by the flux loop based on the value of this product.

#### Note:

Writing the correct value to this parameter:

- In the case of Rexroth motors of the 2AD, ADF lines and in the case of linear and rotary kit motors, by loading the motor parameters with the commissioning software (e.g. IndraWorks).
- In the case of other asynchronous motors: manual input according to manufacturer's specification.
- In the case of synchronous motors, the parameter is not used and automatically set to  $A_{\text{eff}} = 0$ .

See also Functional Description "Motor, Mechanical Axis System, Measuring Systems"

### P-0-4005, Flux-generating current, limit value

	Input min/max:	Default value:	Unit:
MPB:	var. / 0,000	0,000	A eff

**Function** In this parameter a negative limit value for the flux-generating current can be entered.

This limit value is available for field weakening operation of synchronous motors and therefore exclusively takes effect for synchronous motors for which field weakening operation was allowed (see parameter **P-0-0045, Control word of current controller**).

#### Note:

Writing the correct value to this parameter:

- In the case of Rexroth motors of the MHD, MKD, MKE and MSK lines, automatically at initial commissioning.
- In the case of linear and rotary synchronous kit motors by loading the motor parameters with the commissioning software (e.g. IndraWorks).
- In the case of other synchronous motors: manual input according to manufacturer's specification.
- In the case of asynchronous motors, this parameter is automatically set to  $A_{\text{eff}} = 0$ .

See also Functional Description "Limitations"

**P-0-4014, Type of construction of motor**

	Input min/max:	Default value:	Unit:
MPB:	--- / ---	---	--

- Function** By this parameter the controller is informed of control-relevant features of the connected motor, such as
- functional principle
  - type of construction
  - encoder data memory

See also Functional Description "General Information on the Operation of Motors with IndraDrive"

**P-0-4022, Drive address of serial interface**

	Input min/max:	Default value:	Unit:
MPB:	1 / 99	256	--

- Function** By means of this parameter it is possible to set the address for the serial interface. This can be done via the control panel, the serial interface or the master communication interface.

---

**Note:** The effective address can be directly taken from P-0-4022 or from the list **P-0-4031, Overview of device addresses!**

---

See also Functional Description "Serial Communication"

See also Parameter Description "P-0-4031, Overview of device addresses"

**P-0-4025, Drive address of master communication**

	Input min/max:	Default value:	Unit:
MPB:	1 / 99	---	--

- Function** By means of this parameter it is possible to set the address for the master communication (e.g. SERCOS, Profibus...). This can be done via the control panel, the serial interface or the master communication interface itself.

---

**Note:** The currently effective address can be directly taken from parameter **S-0-0096, Slave arrangement (SLKN)** or **P-0-4031, Overview of device addresses!**

---

See also Functional Description "Serial Communication"

**P-0-4028, Device control word**

	Input min/max:	Default value:	Unit:
MPB:	--- / ---	---	--

- Function** This parameter is used to control the drive in the following cases:
- for devices with analog or parallel master communication
  - When the drive is switched to the "easy startup mode" via the control panel.

---

**Note:** In the case of master communication via field bus or SERCOS, **P-0-4077, Field bus: control word** and **S-0-0134, Master control word** are used accordingly for controlling the drive!

---

See also Functional Description "Master Communication"

See also Functional Description "Operating Modes"

### P-0-4031, Overview of device addresses

	Input min/max:	Default value:	Unit:
<b>MPB:</b>	--- / ---	---	--

- Function** This parameter is used to display the following addresses in clearly structured and holistic form which is particularly important for multi-axis devices:

- effective drive address of master communication that was set via parameter P-0-4025
- effective drive address of serial interface that was set via parameter P-0-4022

---

**Note:** Especially for multi-axis devices (e.g. HMD01.1) the parameter P-0-4031 provides a clear overview as regards the axis addresses effective in the device.

---

### P-0-4032, Motor type plate data

	Input min/max:	Default value:	Unit:
<b>MPB:</b>	0,000 / 250000,000	---	--

- Function** For asynchronous third-party motors it is possible via **C3200 Command Calculate motor data** to calculate the values for motor parameters from the type plate data and then the values of the motor control parameters. The activation of C3200 first requires manual input of the motor data from the type plate of the asynchronous motor in the list parameter **P-0-4032, Motor type plate data**.

---

**Note:** When a Rexroth motor is used, the content of P-0-4032 and the command C3200 are irrelevant as for these motors all parameters required for operation are stored in the data base for motor data (DriveBase).

---

See also Functional Description "Automatic Setting of Motor Control Parameters"

### P-0-4033, C3200 Command Calculate motor data

	Input min/max:	Default value:	Unit:
--	----------------	----------------	-------

MPB: --- / --- --- --

**Function** For asynchronous third-party motors it is possible via **C3200 Command Calculate motor data** to calculate the values for motor parameters from the type plate data and then the values of the motor control parameters. The activation of C3200 first requires manual input of the motor data from the type plate of the asynchronous motor in the list parameter **P-0-4032, Motor type plate data**.

**Note:** When a Rexroth motor is used, the content of P-0-4032 and the command C3200 are irrelevant as for these motors all parameters required for operation are stored in the data base for motor data (DriveBase).

See also Functional Description "Automatic Setting of Motor Control Parameters"

### P-0-4036, Rated motor speed

	Input min/max:	Default value:	Unit:
MPB:	0,0000 / 429496,7295	1000,0000	Rpm

**Function** This parameter defines the speed that begins above the field weakening range. Voltage reference value is DC bus voltage DC540V (uncontrolled supply at 3xAC400V -5%).

**Note:**

Writing the correct value to this parameter:

- for Rexroth motors of the MAD and MAF lines, if an encoder data memory is available, automatically at initial commissioning
- for linear and rotary asynchronous kit motors by loading the motor parameters with the "IndraWorks D" commissioning tool
- for other asynchronous motors manual input according to manufacturer's specification (see completed form for the output data of asynchronous motors!)
- The parameter is not used for synchronous motors.

See also Functional Description "Motor Control"

### P-0-4039, Stator leakage inductance

	Input min/max:	Default value:	Unit:
MPB:	0,001 / 4294967,295	5,000	mH

**Function** This parameter is only used for operating asynchronous motors and takes effect for current control of the motor.

For Rexroth motors this value is stored in the DriveBase.

For third-party motors this parameter is calculated via the command **C3200 Command Calculate data for asynchronous motor** that is started with P-0-4033.

### P-0-4040, Rotor leakage inductance

	Input min/max:	Default value:	Unit:
MPB:	0,001 / 4294967,295	5,000	mH

**Function** This parameter is only used for operating asynchronous motors and takes effect for current control of the motor.

For Rexroth motors this value is stored in the DriveBase.

For third-party motors this parameter is calculated via the command **C3200 Command Calculate data for asynchronous motor** that is started with P-0-4033.

### P-0-4041, Motor magnetizing inductance

	Input min/max:	Default value:	Unit:
MPB:	0,010 / 4294967,295	50,000	mH

**Function** This parameter is only used for operating asynchronous motors and takes effect for current control of the motor.

For Rexroth motors this value is stored in the DriveBase. For third-party motors this parameter is calculated via the command **C3200 Command Calculate data for asynchronous motor** that is started with P-0-4033.

See also Functional Description "Determining the Motor Parameter Values"

### P-0-4042, Characteristic of motor magnetizing inductance

	Input min/max:	Default value:	Unit:
MPB:	0,500 / 2,000	---	--

**Function** This list parameter is only used for operating asynchronous motors and takes effect for current control of the motor.

- For Rexroth motors the characteristic values are made available by the manufacturer, either by means of a data sheet or the commissioning software (e.g. IndraWorks).
- For third-party motors the characteristic in the majority of cases is unknown. Via the command **C3200 Command Calculate data for asynchronous motor** that is started with P-0-4033 the list is neutrally assigned.
- Via the command **C3600 Command Motor data identification** that is started with P-0-0565 the characteristic of the asynchronous motor is determined and entered in this list.

See also Functional Description "Motor Control"

### P-0-4043, Rotor time constant

	Input min/max:	Default value:	Unit:
MPB:	0,100 / 10000,000	100,000	ms

**Function** This parameter is only active for asynchronous motors. It has a considerable influence on the torque generation of the motor, as it decisively determines the so-called "slip" in the case of load.

---

**Note:** "Slip" is the difference of the rotational frequency of the electric rotary field in the stator divided by the number of pole pairs of the motor and the mechanical rotational frequency of the rotor.

---

The value for P-0-4043 is motor-specific and for asynchronous Rexroth motors is made available via the commissioning software (e.g. IndraWorks) or via the Intranet output of the manufacturer-side data base DriveBase!

### P-0-4045, Maximum possible continuous current

	Input min/max:	Default value:	Unit:
<b>MPB:</b>	--- / ---	---	A eff

**Function** This parameter indicates how much current the controller can continuously provide in the present load situation. At the same time, this current is the current to which the continuous current limitation would reduce, if the load situation would continue.

See also Functional Description "Current Limitation"

### P-0-4046, Effective peak current

	Input min/max:	Default value:	Unit:
<b>MPB:</b>	--- / ---	---	A eff

**Function** This parameter displays the maximum current that the controller can temporarily supply to the motor in the active load condition. This is the rms value of the total current, i.e. torque-generating and magnetic-field-generating components are contained!

See also Functional Description "Current Limitation"

### P-0-4065, Non-volatile memory active

	Input min/max:	Default value:	Unit:
<b>MPB:</b>	--- / ---	2	--

**Function** This parameter contains information on the active, non-volatile memory. The parameter values and, in the case of control voltage failure, the retain data are stored in the active memory.

Meaning of the value:

- 1: MultiMediaCard (MMC) is the active, non-volatile memory
- 2: internal, non-volatile memory is active

See also Functional Description "Parameters, Basics"

### P-0-4068, Field bus: control word IO

	Input min/max:	Default value:	Unit:
<b>MPB:</b>	--- / ---	0	--



**Function** The parameter **P-0-4068, Field bus: control word IO** is used as field bus control word (16 bits) in the I/O mode. We distinguish the two following profile types with freely expandable real-time data and configurable field bus status word:

- "I/O mode positioning" (P-0-4084, Field bus: Profile type = 0xFF82)
- "I/O mode preset velocity" (P-0-4084, Field bus: Profile type = 0xFF82)

See also Functional Description "Profile Types - I/O Mode"

### P-0-4069, Field bus: module diagnosis

	Input min/max:	Default value:	Unit:
MPB:	--- / ---	---	--

**Function** Parameter for reading master communication settings and states (with field buses).

---

**Note:** This parameter is only relevant for the development staff! It is irrelevant for the application side!

---

See also Functional Description "PROFIBUS-DP"

### P-0-4071, Field bus: length of cyclic command value data channel

	Input min/max:	Default value:	Unit:
MPB:	0 / 32	2	Byte

**Function** This parameter indicates the number of bytes of the process data channel parameterized in **P-0-4081, Field bus: config. list of cyclic command value data ch.**

This length does not contain the length parameterized in **P-0-4083, Field bus: length of parameter channel** of a possibly available parameter channel. The graduation takes place in word boundaries, i.e. possible values are 2, 4, 6, ... 32.

---

**Note:** For communication via Interbus it is obligatory, due to the bus structure (shift register), that P-0-4071 = P-0-4082.

---

See also Functional Description "PROFIBUS-DP"

### P-0-4072, C2900 Command Firmware update from MMC

	Input min/max:	Default value:	Unit:
MPB:	--- / ---	---	--

**Function** With this command, the firmware is copied from the MultiMediaCard plugged in the controller to the controller and to possibly available firmware-carrying additional components.

The command can be started via the control panel or via a commissioning tool ("IndraWorks D" or "SynTop"). After successful firmware update the message "End C29" is displayed. The user now has to switch the drive off and on again so that the new firmware becomes active.

**Note:** If you make an attempt of phase progression without the drive having been rebooted, either a switching command error will occur or a system error (F8xxx) entered before the firmware update will be displayed.

See also Functional Description "MultiMediaCard (MMC)"

### P-0-4073, Field bus: diagnostic message

	Input min/max:	Default value:	Unit:
MPB:	--- / ---	---	--

**Function** This parameter contains the status of the field bus status machine in plain text. The diagnostic messages depends on the field bus used and is according to the designations used in the standard.

See also Functional Description "PROFIBUS-DP"

### P-0-4074, Field bus: data format

	Input min/max:	Default value:	Unit:
MPB:	0 / 1	0	--

**Function** Parameter **P-0-4074, Field bus: data format** describes the arrangement of 32-bit-values in the telegram (process data channel).

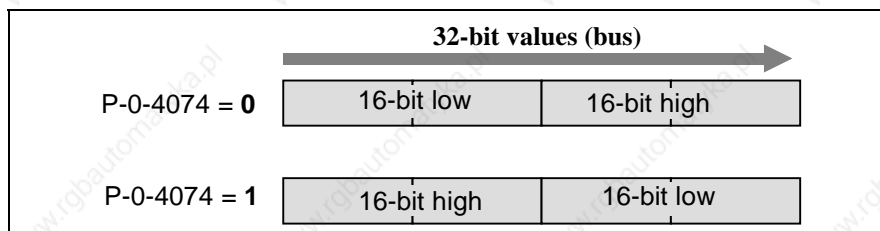

P-0-4074, Field bus: data format

See also Functional Description "PROFIBUS-DP"

### P-0-4075, Field bus: watchdog

	Input min/max:	Default value:	Unit:
MPB:	--- / ---	0	ms

**Function** In this parameter the watchdog time transmitted by the master in the parameterization telegram is stored in ms. If the master communication is interrupted for more than this time, a communication error is generated.

See also Functional Description "PROFIBUS-DP"

### P-0-4076, Field bus: cycle time (Tcyc)

	Input min/max:	Default value:	Unit:
MPB:	500 / 65000	2000	us

**Function** The content of **P-0-4076, Field bus: cycle time (T<sub>cyc</sub>)** defines the time intervals in which the cyclic real-time data (command values and actual values) are processed in the field bus drive.

See also Functional Description "PROFIBUS-DP"

### P-0-4077, Field bus: control word

	Input min/max:	Default value:	Unit:
<b>MPB:</b>	--- / ---	0	--

**Function** This parameter is used as field bus control word for all BRC profiles such as "freely configurable mode" (0xFFFE).

---

**Note:** The significance and function of the control bits cannot be configured and is defined by the profile selection!

---

See also Functional Description "Profile Types - Rexroth Profile Types"

### P-0-4078, Field bus: status word

	Input min/max:	Default value:	Unit:
<b>MPB:</b>	--- / ---	0	--

**Function** In the case of field bus drives that are operated in the freely configurable profile type (P-0-4084 = 0xFFFE), the parameter **P-0-4078, Field bus: status word** is used as status word for feedback of the drive status to the field bus master.

---

**Note:** The configuration of **P-0-4078, Field bus: status word** cannot be changed, i.e. the bit assignment is fixed and cannot be parameterized.

---

See also Functional Description "Supported Profile Types"

### P-0-4079, Field bus: baud rate

	Input min/max:	Default value:	Unit:
<b>MPB:</b>	--- / ---	0,00	kBaud

**Function** Parameter P-0-4079 contains the active baud rate of the field bus interface. You have to distinguish the following cases:

- **PROFIBUS-DP and PROFINet:**  
The baud rate used by the field bus is automatically determined and only displayed in this parameter.
- **DeviceNet and CanOpen:**  
The baud rate used by the field bus is set in parameter P-0-4079.

---

**Note:** By inputting "0" as baud rate it is possible to activate automatic baud rate detection. In some cases this however might not work correctly so that it is recommended to make a manual input.

---

See also Functional Description "PROFIBUS-DP"

See also Functional Description "PROFINet"

See also Functional Description "CANopen"

See also Functional Description "DeviceNet"

### P-0-4080, Field bus: config. list of cyclic actual value data ch.

	Input min/max:	Default value:	Unit:
MPB:	--- / ---	---	--

**Function** With this parameter the process input data channel (slave-master, i.e. "AT") is configured independent of the field bus used.

See also Functional Description "PROFIBUS-DP"

### P-0-4081, Field bus: config. list of cyclic command value data ch.

	Input min/max:	Default value:	Unit:
MPB:	--- / ---	---	--

**Function** With this parameter the process output data channel (master-slave, i.e. "MDT") is configured independent of the field bus used.

See also Functional Description "PROFIBUS-DP"

### P-0-4082, Field bus: length of cyclic actual value data channel

	Input min/max:	Default value:	Unit:
MPB:	0 / 32	2	Byte

**Function** This parameter indicates the number of bytes of the process data channel parameterized in **P-0-4080, Field bus: config. list of cyclic actual value data ch.**

This length does not contain the length parameterized in **P-0-4083, Field bus: length of parameter channel** of a possibly available parameter channel. The graduation takes place in word boundaries, i.e. possible values are 2, 4, 6, ... 32.

---

**Note:** For communication via Interbus it is obligatory, due to the bus structure (shift register), that P-0-4071 = P-0-4082.

---

See also Functional Description "PROFIBUS-DP"

### P-0-4083, Field bus: length of parameter channel

	Input min/max:	Default value:	Unit:
MPB:	0 / 16	---	Byte

**Function** Apart from the transmission of real-time data (also called process data), communication via a field bus also requires the transmission of

parameters that are not linked to a real-time cycle. In the case of PROFIBUS, for which not all control units are supporting acyclic access, these data can be exchanged via a parameter channel.

See also Functional Description "PROFIBUS-DP"

### P-0-4084, Field bus: profile type

	Input min/max:	Default value:	Unit:
MPB:	--- / ---	0xFF82	--

- Function** The setting of **P-0-4084, Field bus: profile type** influences
- the profile-dependent interpretation of the control and status words
  - the preselection of the primary mode of operation set in the drive
  - the configuration of the real-time data channel (unless freely configurable).

See also Functional Description "PROFIBUS-DP"

### P-0-4085, C4700 Command Activate easy startup mode

	Input min/max:	Default value:	Unit:
MPB:	--- / ---	---	--

- Function** This parameter is used for activating the easy startup mode via the serial interface. With the start of this command the drive switches master communication (SERCOS or Profibus) off. The drive automatically switches to the parameter mode, makes the parameter setting for the "easy startup mode" and switches to the operating mode. The parameter setting is stored in volatile form. The easy startup mode can only be deactivated by switching control voltage off and on.

### P-0-4086, Master communication status

	Input min/max:	Default value:	Unit:
MPB:	--- / ---	---	--

- Function** This parameter contains important status information regarding the current status of master communication or device control. Independent thereof some control information for handling the communication phase switch, as well as for enabling the hardware inputs for drive enable and Drive Halt, is controlled.

---

**Note:** Users cannot write this parameter, it is only used for diagnostic purposes.

---

See also Functional Description "Initial Start in "Easy Startup" Mode"

See also Functional Description "Device Control (Status Machine)"

See also Functional Description "Master Communication"

### P-0-4090, Configuration for loading default values

	Input min/max:	Default value:	Unit:
MPB:	--- / ---	---	--

**Function** The effects of the command **S-0-0262, C07\_x Load defaults procedure command** depend on the configuration available in P-0-4090 at the command start.

See also Functional Description "Loading Default Values"

See also Parameter Description "S-0-0262, C07\_x Load defaults procedure command"

### P-0-4091, C2500 Copy IDN from optional memory to internal memory

	Input min/max:	Default value:	Unit:
MPB:	--- / ---	---	--

**Function** By means of this command the parameter values are copied from the MultiMediaCard (MMC) to the internal, non-volatile memory (flash).

### P-0-4092, C2600 Copy IDN from internal memory to optional memory

	Input min/max:	Default value:	Unit:
MPB:	--- / ---	---	--

**Function** By means of this command the parameter values are copied from the internal, non-volatile memory (flash) to the MultiMediaCard (MMC).

### P-0-4095, RS-232/485 Parity

	Input min/max:	Default value:	Unit:
MPB:	0 / 2	0	--

**Function** By means of this parameter it is possible to set several parities for the communication via the serial interface.

Parity	Setting in P-0-4095
none	0
odd	1
even	2

Fig. 7-48: Coding of the parity in P-0-4095

The initial setting is no parity (default value).

See also Functional Description "Serial Communication"

## 7.4 Basic Functions

### Serial Communication

The serial interface of the drive controller is used as a universal medium of communication for different services. It can be used for master communication (in addition to SERCOS), for reading and writing

parameters, for replacing the firmware, for locating errors and for other services. The physical standard used is RS232 (with accessory HAS05.1-005 "RS232/RS485 converter", RS485 is possible, too).

Two protocols are supported for serial communication:

- ASCII-based protocol
- SIS protocol (Rexroth-standard serial binary protocol)

---

**Note:** The protocol is automatically recognized by the drive!

---

The following functions are made possible via the serial interface:

- reading and writing parameters via terminal or commissioning tool in parallel with the existing master communication
- connecting a control terminal (BTV04)
- downloading firmware via the "IndraWorks D" program

The maximum baud rate is 115 kB.

### General Information on the Parameter Structure

All parameters of the drive controller are stored in a uniform parameter structure. Each parameter consists of 7 elements. The table below describes the individual elements and the possibilities of access. The following sections will also refer to the parameter structure below.

Element No.	Data block element	Possibility of access
1	IDN	read
2	name	read
3	attribute	read
4	unit	read
5	min. input value	read
6	max. input value	read
7	operating data	read / write

Fig. 7-49: Parameter structure

### Interface Mode

The serial interface can optionally be operated in the

- RS232 mode or
- RS485 mode.

---

**Note:** Communication via RS485 is only possible in conjunction with an external RS232/RS485 converter (e.g. with accessory module HAS05.1-005 by Bosch Rexroth).

Depending on the mode, it is necessary to use different cables (see Project Planning Manual).

---

### Transmission Protocols

Two different protocols are supported on the drive side:

- ASCII protocol
- SIS protocol

When switching on the 24 V supply voltage an automatic protocol detection is activated when receiving signals via the serial interface.

As soon as either

- a valid ASCII start sequence

- or -

- a valid SIS telegram

was received the drive internally switches to the respective kind of protocol.

#### Properties of ASCII Protocol

- transmission rates of 9600 and 19200 baud
- 8-bit ASCII protocol
- no parity bit
- one stop bit

---

**Note:** There isn't any telegram frame used but the transmitted ASCII signs are converted and interpreted. It is only necessary to comply with a certain order.

---

#### Properties of SIS Protocol

- binary protocol
- checksum test (higher Hamming distance D)
- all telegrams are identified by an unequivocal start character ("0x02")
- defined structure of the telegram frame
- it is possible to activate motions (e.g. jogging)

## Master Communication

### General

- **address assignment**  
→ communication address to be freely parameterized (via master communication, serial and control panel) via parameter **P-0-4025, Drive address of master communication**
- **Baud rate PROFIBUS-DP**  
**P-0-4079, Field bus: Baud rate**

The baud rate used by the field bus is automatically determined and only displayed in this parameter.

---

**Note:** By inputting "0" as baud rate it is possible to activate automatic baud rate detection. In some cases this however might not work correctly so that it is recommended to make a manual input.

---

### Open Loop

In operation without encoder (open-loop operation) the velocity control loop is not closed in the drive, but the drive is operated in a velocity-controlled way (without feedback) via open-loop U/f control.

---

**Note:** The method of open-loop/closed-loop motor control can be selected via bit 14 of parameter **P-0-0045, Control word of current controller**.

---



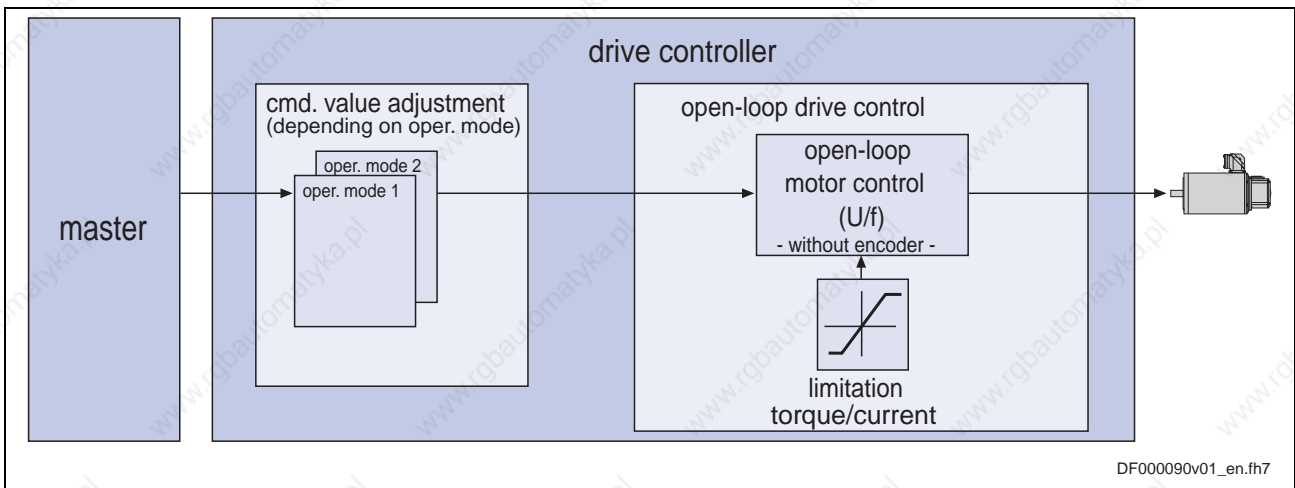

Fig. 7-50: Principle of drive control in open-loop operation

**Features**

The velocity control has the following features:

- fine interpolation of the velocity command value (can be switched off)
- monitoring of the velocity control loop (can be switched off via P-0-0556, bit 1)
- filtering of actual velocity value to be parameterized
- additive velocity command value (S-0-0037)
- display of resulting command value (in P-0-0048)
- monitoring and **limitation** of the maximum stator frequency change that results from the command velocity change
- **stall protection loop** (PI loop that can be optionally activated to prevent breakdown of the machine when the torque limits are attained)
- slip compensation (feedforward of estimated slip of the machine by means of rotor time constant and slip compensation factor)
- calculation of output voltage by means of a **U/f characteristic** based on motor model data
- subsequent trimming of magnetization via premagnetization factor (linear or square characteristic to be selected)
- **IxR boost** (adjustable load-dependent feedforward of the output voltage due to the voltage drop on the motor winding resistance)
- **oscillation damping** (adjustable load-dependent feedforward to prevent velocity oscillations in the partial load and idling ranges)
- **current limitation loop** to protect the output stage
- **velocity search mode** of a coasting machine after switching drive enable on (can be set for one or both rotational directions)

**Profibus Interface****Overview**

Drive controllers of the IndraDrive range have a master communication module with PROFIBUS interface. Via this module it is possible to exchange real-time data with a PROFIBUS-DP master.

Using the master communication "PROFIBUS-DP" requires the following control section design:

- single-axis BASIC PROFIBUS (not configurable) (CSB01.1N-PB)

In addition it is possible to use the following configurable control sections if they have been designed with the optional module **PB**:

- single-axis BASIC UNIVERSAL (CSB01.1C)
- single-axis ADVANCED (CSH01.1C)

- double-axis BASIC UNIVERSAL (CDB01.1C)

The following communication channels are distinguished:

- **cyclic data channel** (PROFIBUS-DP)

The field bus provides data containers in which useful data can be cyclically transmitted. This section is called cyclic data channel. The cyclic data channel is divided into

- a device-specific **parameter channel** (optional) for reading and writing all parameters via PROFIBUS-DP,

---

**Note:** This parameter channel does not fulfill "real-time properties"!

---

- an (optional) **safety related**, axis-specific process data channel (PROFIsafe) that allows transmitting safety-relevant signals depending on firmware and hardware (see also "Drive-Integrated Safety Technology" in chapter "Drive Functions"),
- an axis-specific **process data channel** (real-time channel) containing firmly specified information that can be directly interpreted by the receiver.
- **acyclic data channel** (DPV1 parameter communication)

The following are supported:

- one class-1 connection
- two class-2 connections

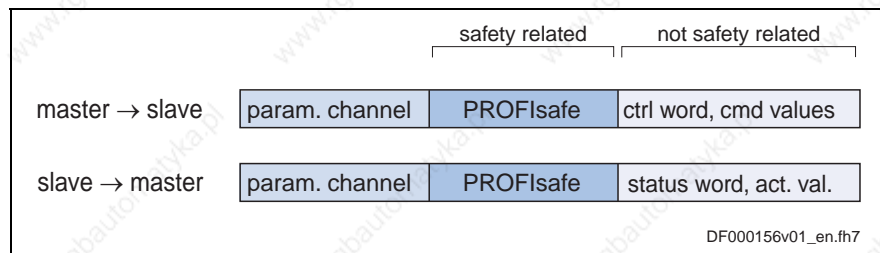

Fig. 7-51: Overview cyclic data channel

**Note:** To simplify field bus communication Bosch Rexroth makes available function blocks for different programmable logic controllers (PLCs). The principles applied can be easily used for other field bus masters.

The slave PROFIBUS-DP circuit with master communication module PL has the following functional features:

#### Features

- support of **RS485 interfaces according to IEC61158-2**
- support of all **data rates according to IEC61158-2**, with exclusive use of PROFIBUS-DP (9.6 kBaud, 19.2 kBaud, 45.45 kBaud, 93.75 kBaud, 187.5 kBaud, 500 kBaud, 1.5 MBaud, 3 MBaud, 6 MBaud, 12 MBaud)
- automatic baud rate detection
- configurable **cyclic data** up to 10 parameters (incl. field bus control word and field bus status word) in both data directions (max. 40 bytes or 20 words)
- additional optional **parameter channel** in the cyclic channel with up to 16 bytes (8 words)
- monitoring of the cyclical data exchange (watchdog function)
- LED for diagnosing the PROFIBUS interface

- supported DPV0 services:
  - Slave\_Diag (read diagnostic data)
  - Get\_Cfg (read configuration data)
  - Set\_Prm (send parameterization data)
  - Chk\_Cfg (check configuration data)
  - Data Exchange (transfer I/O data)
  - Global Control (synchronization)
  - RD\_Outp (read output data)
  - RD\_Inp (read input data)
- parameter access with DPV1-class-1 services
  - DDLM\_Initiate (establishment of connection)
  - DDLM\_Read (acyclic read access)
  - DDLM\_Write (acyclic write access)
  - DDLM\_Abort (abortion of connection)
  - DDLM\_Idle (connection monitoring)
- support of up to two DPV1-class-2 connections
- supported field bus profiles:
  - 0xFF82: I/O mode "positioning" with configurable real-time data
  - 0xFF92: I/O mode "preset velocity" with configurable real-time data
  - 0xFFFE: freely configurable mode
- access to all device parameters according to PROFIdrive specification

#### Pertinent Parameters

##### Communication Parameters

Specific parameters for communication via PROFIBUS-DP:

- **P-0-3290, PROFIsafe: F\_Destination\_Address**
- **P-0-4069, Field bus: module diagnosis**

Parameters for general communication via field bus interfaces:

- **P-0-4073, Field bus: diagnostic message**
- **P-0-4074, Field bus: data format**
- **P-0-4075, Field bus: watchdog**
- **P-0-4076, Field bus: cycle time (Tcyc)**
- **P-0-4079, Field bus: baud rate**

##### Profile Type Parameters

Apart from mere communication parameters, we use parameters in conjunction with the profile types.

See also section "Profile Types (with Field Bus Interfaces)" in the same chapter

##### Parameters for Extended Communication

We use additional parameters for extended communication.

See the following sections under "Possibilities of Control/Additional Functions" in the same chapter:

- "Configurable Signal Control Word"
- "Configurable Signal Status Word"
- "Multiplex Channel"

## Profile Types

### IO Mode - Supported Profile Types

When a field bus interface is used for master communication, IndraDrive controllers support the following profile types (modes):

- I/O mode positioning
- I/O mode preset velocity
- freely configurable mode (Rexroth profile type)

The table below contains an overview of the most important properties and features of the 3 profile types:

Content of P-0-4084, Profile type	Master communication	Field bus or drive operating mode	Features
<b>Profile type: I/O mode positioning</b>			
FF82h	PROFIBUS, CANopen, DeviceNet	I/O mode positioning (positioning block mode, encoder 1, lagless)	<ul style="list-style-type: none"> <li>- up to 64 positioning blocks can be controlled via field bus</li> <li>- apart from control and status word, other real-time data can be configured (in P-0-4080 and P-0-4081)</li> <li>- bits can be freely defined in signal status word via function "configurable signal status word"</li> </ul>
<b>Profile type: I/O mode preset velocity</b>			
FF92h	PROFIBUS, CANopen, DeviceNet	I/O mode preset velocity	<ul style="list-style-type: none"> <li>- fixed velocity command values can be controlled and ramp generator can be operated via field bus</li> <li>- apart from control and status word, other real-time data can be configured (in P-0-4080 and P-0-4081)</li> <li>- bits can be freely defined in signal status word via function "configurable signal status word"</li> </ul>
<b>Profile type: freely configurable mode</b>			
FFFEh	PROFIBUS, CANopen, DeviceNet	freely configurable mode (default assignment is "drive-controlled positioning" with corresponding required cyclic data)	<ul style="list-style-type: none"> <li>- possible use of complete drive functionality by free configuration of real-time data and operating mode selection</li> <li>- control and status word have a Rexroth-specific structure</li> <li>- selection suited for operation with analog command values in commissioning phase</li> </ul>
FFFDh	like profile FFFEh, but reduced field bus control word (relevant for MLD applications, for example)		

Fig. 7-52: Supported profile types for IndraDrive firmware

### Basic Principles and Terms

#### Drive Profile

The drive profile defines

- the structure of the field bus control word (P-0-4077) and of the field bus status word (P-0-4078),
- the structure and content of real-time channel (P-0-4080, P-0-4081),
- the active operating mode (S-0-0032, S-0-0033, S-0-0034, S-0-0035)
- the drive states and their transitions (status machine of I/O mode or Rexroth profile type).

By selecting a profile type, the commissioning of field bus drives becomes very easy for the user. The advantage of the profile selection is that all important basic settings for the desired drive function are thereby made automatically in the drive. As the profile types are defined independently of the bus, the transfer of applications from one field bus to the other is also facilitated.

**Status Machine** A status (e.g. Drive Halt, drive error, ...) represents a specific internal and external behavior. The status can be exited by defined events (e.g. drive commands, switching of operating modes, ...). Corresponding status transitions are assigned to the events. The interaction of control and status bits or the status transitions are called status machine.

**Abbreviations**

**i16:** 16-bit variable with sign (1 word) in Intel format  
**i32:** 32-bit variable with sign (2 words) in Intel format  
**u16:** 16-bit variable without sign (1 word) in Intel format  
**u32:** 32-bit variable without sign (2 words) in Intel format  
**ZKL1:** class 1 diagnostics  
**ZKL2:** class 2 diagnostics

### I/O Mode (Positioning and Preset Velocity)

We distinguish the following variants of the profile type "I/O mode":

- I/O mode positioning (functionality similar to parallel interface)
- I/O mode preset velocity (e.g. for open-loop applications)

The I/O mode has the following features:

- General Features**
- optional parameter channel can be activated, if required, via **P-0-4083, Field bus: length of parameter channel** (max. 8 words) (default: P-0-4083 = 0 → without parameter channel)
  - real-time channel consists of at least one word (16 bits), the field bus control word (P-0-4068) and the signal status word (S-0-0144)

Data direction	Word1	Format
master --> slave	<b>P-0-4068, Field bus: control word IO</b>	u16 (1 word)
slave --> master	<b>S-0-0144, Signal status word</b>	u16 (1 word)

- freely expandable real-time channel by configuration of real-time data:
  - **Master → slave** (drive)  
configuration of **P-0-4081, Field bus: config. list of cyclic command value data ch.**
  - **Slave** (drive) → **master**  
configuration of **P-0-4080, Field bus: config. list of cyclic actual value data ch.**
- freely configurable field bus status word (cf. **S-0-0144**)
- Relationship between profile type selection and operating mode which takes effect:
  - In the **I/O modes** there is a determined relationship between profile type and predefined primary mode of operation (S-0-0032).
  - The **freely configurable mode** allows free selection of the operating modes (S-0-0032, S-0-0033, ...).

---

**Note:** The respective default settings are activated by selecting the profile type and subsequent action "load default communication parameters" (see also P-0-4090 and S-0-0262).

---

#### Features of "I/O Mode Positioning"

Specific features of "I/O mode positioning":

- The drive is operated in "positioning block mode, lagless, encoder 1" (see also "Positioning Block Mode" in chapter "Operating Modes").
- In this operating mode, 64 programmable positioning blocks can be selected and started via 6 bits (in the 16 bit wide control word).
- The jog function can be activated in **P-0-4068, Field bus: control word IO**. "Drive-controlled positioning" was set as the 1st secondary operating mode (see also "Drive-Controlled Positioning" in chapter "Operating Modes").

#### Features of "I/O Mode Preset Velocity"

Specific features of "I/O mode preset velocity":

- The drive is operated in the "velocity control" mode (see also "Velocity Control" in chapter "Operating Modes").
- In this operating mode you can, for example, select and start 5 programmable fixed velocity command values (in the 16 bit wide control word) and operate the ramp generator function.

### Freely Configurable Mode (Rexroth Profile Type)

To use the extensive and numerous functions of a Rexroth drive with field bus interface it is necessary, in addition to the I/O modes, to define another profile, the freely configurable mode. This implies the use of a specific control and status word (**P-0-4077, Field bus: control word** and **P-0-4078, Field bus: status word**).

#### Features

- The structure (content) of the real-time data channel must be defined via the configuration parameters P-0-4080 and P-0-4081. No profile-dependent settings and checks are carried out!
- In this profile type it is the Rexroth-specific definitions for the field bus control and status words which apply. Some bits in the parameters **P-0-4077, Field bus: control word** and **P-0-4078, Field bus: status word** can only be used in conjunction with certain operating modes.
- This profile type allows using the entire drive functionalities (e.g. velocity synchronization, drive-controlled positioning, ...).
- The primary mode of operation and the secondary operating modes can be freely determined in the parameters S-0-0032, S-0-0033 etc.
- The operating mode "drive-controlled positioning" is set as default setting with the command values S-0-0282, S-0-0259 and 2x S-0-0000 and the actual values S-0-0386, S-0-0040, S-0-0390 (see also below "Exemplary Configurations: Drive-Controlled Positioning").

---

**Note:** The parameter **P-0-4077, Field bus control word** or **P-0-4078, Field bus status word** must always be contained in the 1<sup>st</sup> place in the configuration parameters P-0-4080 and P-0-4081.

---

#### Real-Time Channel

In the real-time channel of the field bus the data configured in **P-0-4081, Field bus: config. list of cyclic command value data ch.** and

**P-0-4080, Field bus: config. list of cyclic actual value data ch.** are transmitted between master and drive.

Data direction	Word1	Format
master --> slave	<b>P-0-4077, Field bus: control word</b>	u16 (1 word)
	optional command values	:
slave --> master	<b>P-0-4078, Field bus: status word</b>	u16 (1 word)
	optional actual values	:

**Note:** The IDNs of the parameters of the cyclically configurable command values or actual values are listed in **S-0-0188, List of configurable data in the MDT** and **S-0-0187, List of configurable data in the AT**.

Content and order of data in real-time channel:

Data direction	Word1	Word2	...	Word n
master --> slave	P-0-4077	cmd value 1	...	
slave --> master	P-0-4078	actual value 1	...	

## Motor Control

### Open-Loop/Closed-Loop Operation

The IndraDrive firmware supports the following two basic principles of motor control:

- **motor control (U/f control) in open-loop operation**  
→ open-loop-controlled operation without encoder information
- **motor control in closed-loop operation**
  - **with** encoder feedback  
→ closed-loop-controlled operation (position, velocity and current)
  - **without** encoder feedback  
→ closed-loop-controlled operation with motor model (velocity and current)

Via bit 14 and bit 15 of parameter **P-0-0045, Control word of current controller** the method of motor control is selected.

### Cycle Times and PWM Frequencies

Depending on the firmware variant (MPH, MPD or MPB) and the respective control section (CSH01.1, CDB01.1, CSB01.1), there are the following possible cycle times and PWM frequencies:

T <sub>A,current</sub>	P-0-0001	FWA variant	P-0-0556, bit 2	Performance
62,5 μs	16000	MPH	0	Basic
83,3 μs	12000	MPH	0	Basic
125 μs	8000	MPH MPB MPD	0	Basic
125 μs	4000	MPH MPB MPD	0	Basic

250 $\mu$ s	2000 <sup>1)</sup>	MPH MPB	0	Basic
62,5 $\mu$ s	16000	MPH	1	Advanced
83,3 $\mu$ s	12000	MPH	1	Advanced
62,5 $\mu$ s	8000	MPH	1	Advanced
125 $\mu$ s	4000	MPH	1	Advanced

$T_{A\_current}$ : sampling time of current loop

P-0-0001: Switching frequency of power output stage (in Hz)

P-0-0556: Configuration of axis controller

1): only with power section HCS04.1... and MAD/MAF

Fig. 7-53: Cycle times and switching frequencies that can be set

**Note:** Via bit 2 and bit 5 of parameter **P-0-0556, Configuration of axis controller** it is possible to select the performance options depending on the control section design.

See "Overview of Functions: Performance Data" in chapter "System Overview"

## Scaling of Physical Data

The controller via data maps the drive to an internal mathematical model. The status variables of the drive are determined on the basis of:

- position measurement,
- current measurement and
- temperature measurement.

The measured values collected in this way are converted into physical data:

- position, velocity, acceleration and jerk data
- current data, torque and force data
- temperature data and load data

The master transmits command values to the drive that are used by the controller for transforming them at the motor output shaft or mechanical axis system. The drive in return registers and transmits actual values, signals operating and command states and, if necessary, generates error messages and warnings.

Communication between drive and master also takes place by exchanging data.

**Scaling** An operating data (numeric value) can only be evaluated as a physical value, when the numeric value is connected to a physical unit and the position of the decimal point (decimal places). The data thereby is "scaled" in a qualitative and quantitative way.

**Parameters** All data are stored in parameters and transmitted as parameter values (for explanations on parameters see chapter "Parameters, Basics" in chapter "Handling, Diagnostic and Service Functions"). The scaling of the parameters containing data of the following physical values can be defined by the customer:

- position
- velocity
- acceleration
- torque/force



	<ul style="list-style-type: none"> <li>• temperature</li> </ul>
<b>Preferred Scaling/ Parameter Scaling</b>	To simplify the scaling definition so-called "preferred scalings" were predefined. But physical data can also be exchanged in the control-internal format, i.e. without concrete reference to physical units. To do this, the scaling for certain data can be freely set ("parameter scaling").
<b>Linear and Rotary Data</b>	Depending on the kind of motion of motor or load, the data can be displayed <ul style="list-style-type: none"> <li>• in linear form (linear axis or motor motion)</li> <li>- or -</li> <li>• in rotary form (rotary axis or motor motion)</li> </ul>
<b>Motor Reference/Load Reference</b>	In the drive firmware there are mechanical transfer elements between motor and load mapped by means of mathematical models. The physical data can thereby be referred to <ul style="list-style-type: none"> <li>• the point where the load takes effect (load-side data reference)</li> <li>- or -</li> <li>• the point where the force is input (motor-side data reference).</li> </ul>
<b>Absolute/Modulo Evaluation</b>	For technical reasons, the value range of the position data the controller can display is limited.  In the case of axes with limited travel range (e.g. linear axes), the current axis position within the controller-side value range can be unequivocally displayed (see "Measuring Systems: Basics on Measuring Systems, Resolution" in chapter "Motor, Mechanical Axis System, Measuring Systems").  In the case of axes with unlimited travel range (e.g. rotary axes) it is useful to limit the infinite value range of the position data to a finite value. With continuous motion the value range is recurrently run from minimum to maximum value ("modulo" evaluation of the actual position value).
<b>Basic Scaling Settings</b>	First make the basic scaling settings for position, velocity, acceleration and torque/force data. This is only possible in the parameter mode (communication phase 2). You have to determine: <ul style="list-style-type: none"> <li>• scaling type (rotary/linear/without scaling/percentage-based, if necessary)</li> <li>• unit of measurement and unit of time, if necessary</li> <li>• data reference (motor/load)</li> <li>• absolute/modulo format for position data</li> <li>• preferred scaling (predefined) or parameter scaling (can be individually defined)</li> </ul> To do this, set the respective bits in the following parameters: <ul style="list-style-type: none"> <li>• <b>S-0-0076, Position data scaling type</b></li> <li>• <b>S-0-0044, Velocity data scaling type</b></li> <li>• <b>S-0-0160, Acceleration data scaling type</b></li> <li>• <b>S-0-0086, Torque/force data scaling type</b></li> </ul>
<b>Settings and Tips for Modulo Scaling</b>	When selecting "modulo format" the value range limit has to be set in parameter <b>S-0-0103, Modulo value</b> .

---

**Note:** For "modulo format" enter a value greater than or equal to the value of parameter S-0-0103 in parameter **S-0-0278, Maximum travel range!**

---

**WARNING**

**Danger of incorrect actual position value of encoders evaluated in absolute form after switching the drive on, when the mechanical drive system, with the drive switched off, was moved in the case of modulo scaling!**

⇒ Make sure that the mechanical drive system, with the drive switched off, is as a maximum moved by a distance or angle corresponding to half the absolute encoder range (**S-0-0378, Absolute encoder range of motor encoder** or **S-0-0379, Absolute encoder range of optional encoder**)!

### Temperature Scaling

In addition, make the scaling setting for temperature data in parameter **S-0-0208, Temperature data scaling type**.

### Further Settings for Parameter Scaling

#### Individual Settings for Parameter Scaling

position data:

- **S-0-0077, Linear position data scaling factor position data**
- **S-0-0078, Linear position data scaling exponent**
- or -
- **S-0-0079, Rotational position resolution**

velocity data:

- **S-0-0045, Velocity data scaling factor**
- **S-0-0046, Velocity data scaling exponent**

acceleration data:

- **S-0-0161, Acceleration data scaling factor**
- **S-0-0162, Acceleration data scaling exponent**

#### Diagnostic Messages of Scaling Setting

If inadmissible scaling settings were made, they are detected when switching from parameter mode (communication phase 2) to operating mode (communication phase 4). The drive in this case does not reach the operating mode and, according to setting, displays the following command errors:

- **C0122 Incorr. parameteriz. of motor enc. (mechanical system)**
- **C0123 Modulo value for motor encoder cannot be displayed**
- **C0127 Incorr. parameteriz. of opt. enc. (mechanical system)**
- **C0128 Modulo value for optional encoder cannot be displayed**
- **C0140 Rotary scaling not allowed**
- **C0101 Invalid parameters (see S-0-0021)**
- **C0102 Limit error in parameter (-> S-0-0021)**
- **C0103 Parameter conversion error (->S-0-0021)**

#### Example of Scaling Settings

There are many possibilities to make settings for the scaling type. The table below shows useful settings for which there aren't any command errors to be expected:

Mechanical system			Encoder		Useful scaling type settings		
Motorr	Load gear	Feed spindle	Motor encoder	External encoder	Motor reference	Load reference	Modulo
rotary	available	not available	rotary	no	rotary	rotary	possible
rotary	available/ not available	available	rotary	no	rotary	---	possible
rotary	available/ not available	available	rotary	no	---	linear	possible
rotary	available	not available	rotary	rotary	rotary	rotary	possible
rotary	available/ not available	available	rotary	rotary	rotary	---	possible
rotary	available/ not available	available	rotary	rotary	---	linear	possible
rotary	available/ not available	available	rotary	linear	rotary	---	possible
rotary	available/ not available	available	rotary	linear	---	linear	possible
linear	not available	not available	linear	---	---	linear	not possible

Fig. 7-54: Useful scaling type settings depending on mechanical drive system and measuring systems

## 7.5 Voltage-Controlled Operation (Open-Loop U/f Control)

### Overview

The drive function "voltage-controlled operation of asynchronous motors without encoder in open-loop U/f control" is made available in the base package "open-loop" in the "velocity control" mode. When the expansion package "synchronization" has been enabled, the operating mode "velocity synchronization with real/virtual master axis" is additionally available.

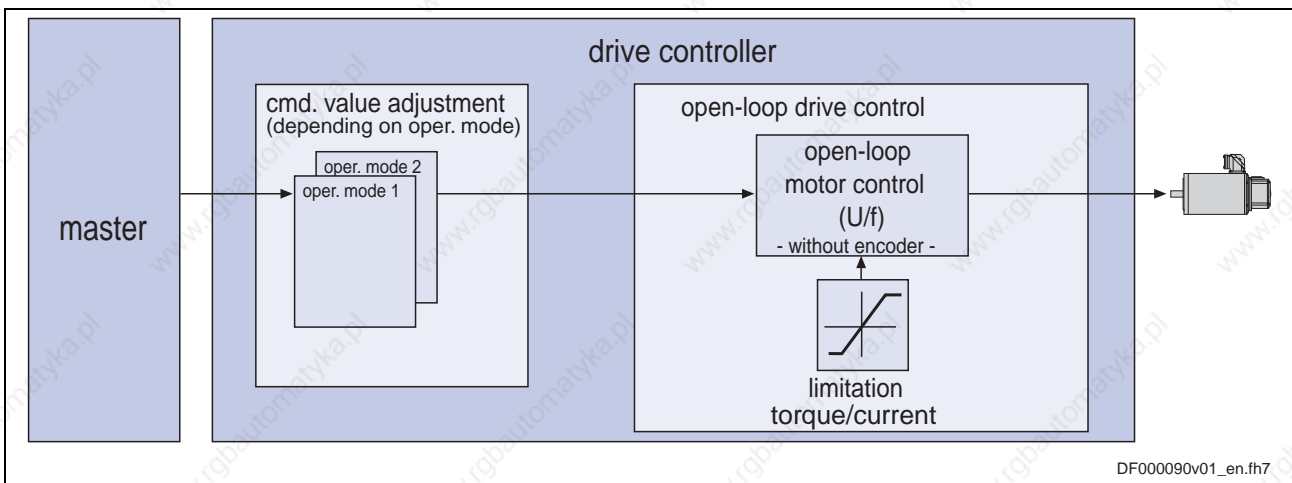

Fig. 7-55: Principle of open-loop U/f control

Open-loop U/f motor control is characterized by the following features or core functions:

- Features**
- monitoring and **limitation** of the maximum **stator frequency change** that results from the command velocity change

- **stall protection loop** (PI loop that can be optionally activated to prevent breakdown of the machine when the torque limits are attained)
- **slip compensation** (feedforward of estimated slip of the machine by means of slip compensation factor)
- calculation of output voltage by means of a **U/f characteristic** based on motor model data
- subsequent trimming of magnetization via premagnetization factor, as well as linear or square characteristic to be selected
- **IxR boost** (adjustable load-dependent feedforward of the output voltage due to the voltage drop on the motor winding resistance)
- **oscillation damping** (adjustable load-dependent feedforward to prevent velocity oscillations in the partial load and idling ranges)
- **current limitation loop** to protect the output stage of the drive controller, as well as limitation to the effective peak current
- **velocity search mode** of a coasting machine after switching drive enable on (can be set for the preset rotational direction or both rotational directions)
- user-side **torque/force limitation** via enabled stall protection loop

## Automatic Setting of Motor Control Parameters

For operating motors it is necessary to collect the values for motor parameters (resistance values, inductances, ...), in order to determine the motor control parameters (flux loop, voltage loop, current loop) with these values.

Depending on the manufacturer and type of the motor to be controlled, the values for motor parameters and motor control parameters are made available to the controller in different ways:

### Motors by Bosch Rexroth

For Rexroth motors the values for the motor and motor control parameters are optimized and made available by the manufacturer. The automatic setting of the motor control parameters by the drive firmware is not required and not allowed for Rexroth motors!

- for motors **with motor encoder data memory**:  
→ automatic loading of the parameters when drive is switched on (see "Overview: Default Settings in the Motor Encoder Data Memory ("load defaults procedure") in section "Closed-Loop Axis Control (Closed-Loop Operation)")
- for motors **without motor encoder data memory**:
  - loading the parameters via the commissioning tool "IndraWorks D" from the motor data base (DriveBase)
  - or -
  - manually writing the individual parameters via the serial interface or the master communication interface by means of a motor parameter list

### Third-Party Motors

For third-party motors the drive firmware possesses commands by means of which the values for the motor and motor control parameters are generated depending on the available output data and the functional principle of the motor.

The following commands are available for calculating values for the motor and motor control parameters:

- **C3200 Command Calculate motor data**
  1. calculating the motor parameter values for asynchronous motors from the **data on the type plate**

2. calculating the values to be set for the motor control parameters

- **C3600 Command Motor data identification**

1. identifying (or optimizing) the motor parameter values for asynchronous motors

**Note:** Appropriate start values already have to be available!

2. calculating the values of the motor control parameters

- **C4600 Command Calculate motor control parameters**

calculating the values of the motor control parameters from the motor parameters for synchronous motors and, if necessary, for asynchronous motors (after manual input of motor data in motor parameters)

---

**Note:** The prerequisite basically is the "Form for Output Data of Asynchronous Motors/Synchronous Motors" to be completed by the motor manufacturer (see "Third-Party Motors at IndraDrive Controllers" in chapter "Motor, Mechanical Axis System, Measuring Systems")!

---

**Overview**

The figure below illustrates an overview of the possibilities of determining the motor and motor control parameters for motors without motor encoder data memory:

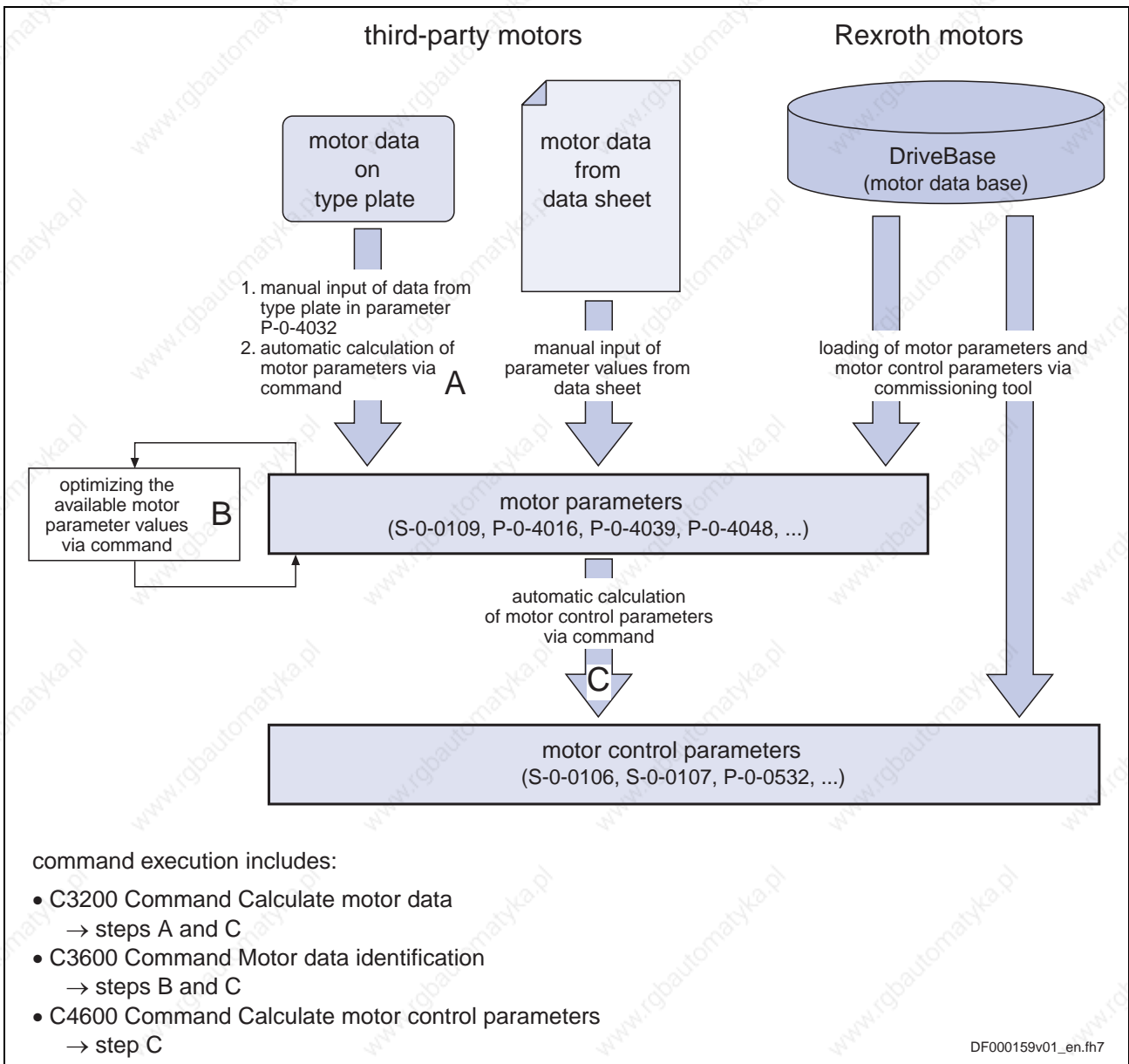

P-0-4032: motor type plate data

Fig. 7-56: Determining the motor and motor control parameters for motors without motor encoder data memory

**Note:** Apart from collecting or determining the motor and motor control parameters, further data on measuring system, temperature sensor, motor temperature model, motor holding brake and, if necessary, position and velocity loop are required.

See also "Closed-Loop Axis Control (Closed-Loop Operation)" in the same chapter

See "Third-Party Motors at IndraDrive Controllers: Notes on Commissioning" in chapter "Motor, Mechanical Axis System, Measuring Systems"

### Overview of Motor and Motor Control Parameters

#### Motor Parameters

The table below contains an overview of the motor parameters for synchronous and asynchronous motors:

Motor parameters	
Synchronous motor	Asynchronous motor
P-0-4014, Type of construction of motor	
S-0-0109, Motor peak current	
S-0-0111, Motor current at standstill	
S-0-0113, Maximum motor speed	
P-0-0018, Number of pole pairs/pole pair distance	
P-0-0051, Torque/force constant	
P-0-0510, Rotor inertia	
P-0-4048, Stator resistance	
P-0-4013, Current limit value of demagnetization	P-0-0530, Slip increase
P-0-4016, Direct-axis inductance of motor	P-0-4004, Magnetizing current
P-0-4017, Quadrature-axis inductance of motor	P-0-4036, Rated motor speed
P-0-4002, Charact. of quadrature-axis induct. of motor, inductances	P-0-4039, Stator leakage inductance
P-0-4003, Charact. of quadrature-axis inductance of motor, currents	P-0-4040, Rotor leakage inductance
P-0-4005, Flux-generating current, limit value	P-0-4041, Motor magnetizing inductance
	P-0-4042, Characteristic of motor magnetizing inductance
	P-0-4043, Rotor time constant

Fig. 7-57: Overview of motor parameters for synchronous and asynchronous motors

**Motor Control Parameters**

The following table contains an overview of the motor control parameters for synchronous and asynchronous motors that are used for field-oriented current control (with and without encoder) and the voltage-controlled operation:

Motor control parameters	
Synchronous motor	Asynchronous motor
<b>Field-oriented current control (FOC)</b>	
S-0-0106, Current loop proportional gain 1	
S-0-0107, Current loop integral action time 1	
P-0-0533, Voltage loop proportional gain	
P-0-0534, Voltage loop integral action time	
P-0-0535, Motor voltage at no load	
P-0-0536, Maximum motor voltage	
	P-0-0528, Flux control loop proportional gain
	P-0-0529, Scaling of stall current limit
	P-0-0532, Premagnetization factor
	P-0-0590, Frequency loop proportional gain
	P-0-0591, Frequency loop integral action time
	P-0-0592, Motor model adjust factor

Voltage-controlled operation (U/f)	
	S-0-0106, Current loop proportional gain 1
	S-0-0107, Current loop integral action time 1
	P-0-0532, Premagnetization factor
	P-0-0568, Voltage boost
	P-0-0569, Maximum stator frequency change
	P-0-0570, Stall protection loop proportional gain
	P-0-0571, Stall protection loop integral action time
	P-0-0572, Slip compensation factor
	P-0-0573, IxR boost factor
	P-0-0574, Oscillation damping factor
	P-0-0575, Search mode: search current factor
	P-0-0576, Search mode: finding point slip factor
	P-0-0577, Square characteristic: lowering factor

Fig. 7-58: Overview of motor control parameters for synchronous and asynchronous motors

### Determining Parameters by Means of Type Plate Data

#### Command "Calculate motor data" (C3200)

For asynchronous motors it is possible via **C3200 Command Calculate motor data** to calculate the values for motor parameters from the type plate data and then the values of the motor control parameters. The activation of C3200 first requires manual input of the motor data from the type plate of the asynchronous motor in parameter **P-0-4032, Motor type plate data**.



See Parameter Description "P-0-4032, Motor type plate data"

**Note:** The command C3200 can only be used for asynchronous motors and can only be activated in communication phases "P2" or "P3"!

The figure below illustrates the scope of functions of the command C3200:



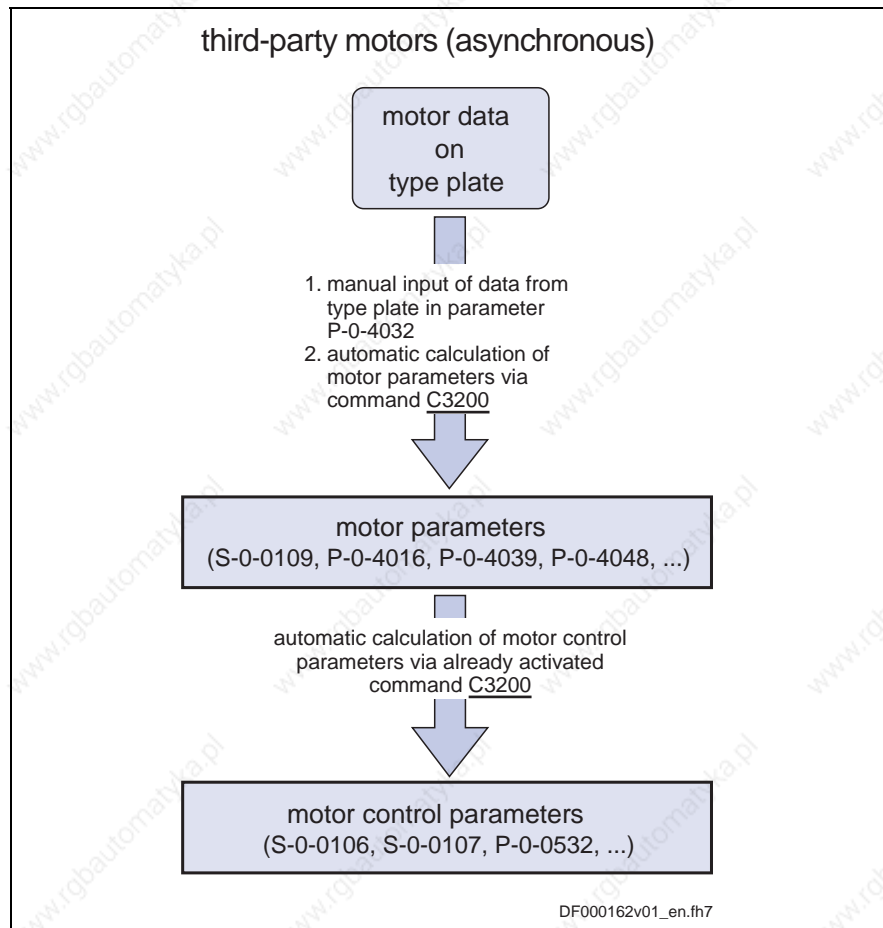

Fig. 7-59: Functions of **C3200 Command Calculate motor data**

**Note:** The type plate does not contain the complete information required for safe operation of the third-party motor! All required data are part of the form of manufacturer-side motor data which has to be available in completed form. The additional data, however, are not required for executing the command C3200.

#### Internally Calculated Parameter Values

By activating the command C3200 (P-0-4033) the following parameter values are calculated from the data of the asynchronous motor entered in list parameter P-0-4032:

- motor parameters
  - motor parameters, general (for synchronous and asynchronous motors)
  - specific motor parameters for asynchronous motors
- motor control parameters
  - motor control parameters for field-oriented current control (FOC) of synchronous and asynchronous motors
  - motor control parameters for field-oriented current control (FOC) of asynchronous motors
  - motor control parameters for voltage-controlled operation (U/f) of asynchronous motors without encoder

#### Annotations

As regards the operating principle of the command C3200, observe the following points:

- Input in parameter P-0-4032 is irrelevant unless the command C3200 has been started.
- When the command was processed without error, the calculated values of motor and motor control parameters are operational.

### Identifying and Optimizing the Motor Parameter Values

#### Command "Motor data identification" (C3600)

For asynchronous motors it is possible via **C3600 Command Motor data identification** to automatically identify and optimize the optimum motor and motor control parameters on the basis of appropriate start values.

**Note:** The command C3600 can only be used for asynchronous motors and can only be activated in the operating mode (communication phase "P4")!

The figure below illustrates the scope of functions of the command C3600:

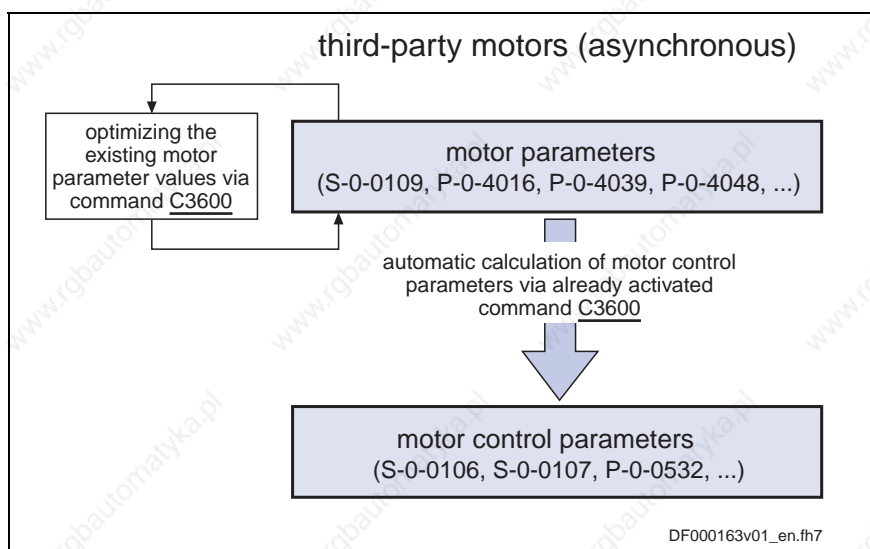

Fig. 7-60: Function of **C3600 Command Motor data identification**

#### Requirements

To execute the command C3600 the following requirements have to be fulfilled:

- manual input of motor data from type plate in parameter **P-0-4032, Motor type plate data** and then execution of **C3200 Command Calculate motor data**
- or -
- manual input of all motor data in the motor parameters according to manufacturer's specification in completed motor data form

#### Sequence of Actions

In status "ready for power output" ("Ab"), current and voltage test signals are transmitted to the motor with the execution of command C3600. In this way the motor parameters for asynchronous motors (see above) are checked and, if necessary, optimized.

A possibly available holding brake continues remaining in the status of control as existing in the operating status "Ab".

After having successfully completed the command execution, the motor and motor control parameters have been optimized and stored.

The following parameters are recalculated:

- motor control parameters for field-oriented current control (FOC) of synchronous and asynchronous motors

- motor control parameters for field-oriented current control (FOC) of asynchronous motors
- motor control parameters for voltage-controlled operation (U/f) of asynchronous motors without encoder

**Annotations** As regards the operating principle of the command C3600, observe the following points:

- Motor motion is not required; the motor holding brake possibly applied at "Ab" remains applied. The motor does not generate torque. With little friction and inertial mass, little motion can however occur!
- When the command was processed without error, the calculated values of motor and motor control parameters are operational. If the command execution is aborted during the measurement, all motor and motor control parameters remain unchanged.

### Calculating the Motor Control Parameters from the Motor Parameters

#### Command "Calculate motor control parameters" (C4600)

For synchronous motors and in special cases (see "Requirements" below) for asynchronous motors it is possible via **C4600 Command Calculate motor control parameters** to calculate the motor control parameters from the motor parameters.

**Note:** The command C4600 can only be activated in the parameter mode (communication phase "P2" or "P3")!

The figure below illustrates the scope of functions of the command C4600:

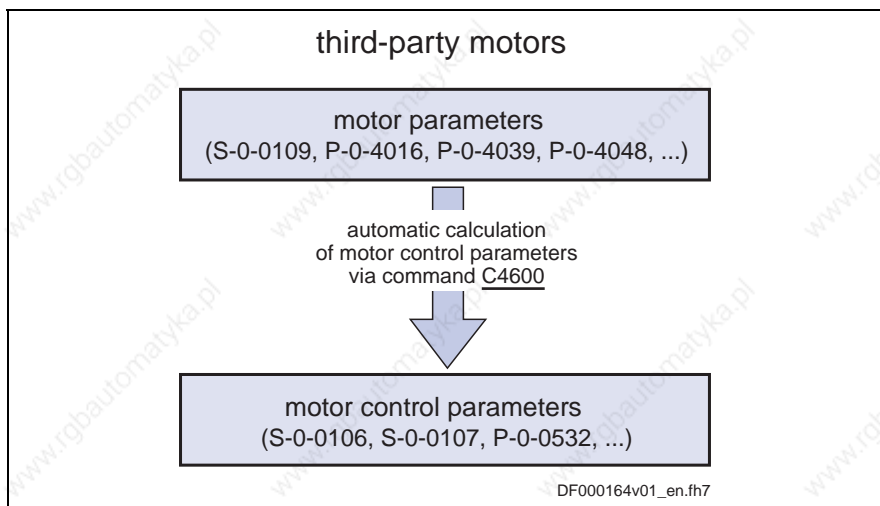

Fig. 7-61: Function of **C4600 Command Calculate motor control parameters**

**Requirements** To execute the command C4600 the following requirements have to be fulfilled:

- **Synchronous third-party motors** require manual input of the motor data in the motor parameters (see "Third-Party Motors at IndraDrive Controllers" in chapter "Motor, Mechanical Axis System, Measuring Systems").
- For **asynchronous third-party motors** the command C4600 is only useful if the motor control parameters are to be generated from specific, manually input motor parameters (e.g. from equivalent circuit diagram data, see "Third-Party Motors at IndraDrive Controllers" in chapter "Motor, Mechanical Axis System, Measuring Systems"). The

calculated values for the motor control parameters thereby might possibly be more exact! It is easier, however, to use the commands C3200 and C3600 (see above) for asynchronous motors.

**Annotations** As regards the operating principle of the command C4600, observe the following points:

- When the command was processed without error, the calculated values of motor and motor control parameters are operational.

### Notes on Commissioning

Motor connected to controller				Parameter values made available	
Motor manufacturer	Motor design	Motor type	Encoder data memory	Motor parameters	Motor control parameters
Bosch Rexroth	housing	MHD, MKD, MKE, MSK, SF, MAD, MAF	yes	A	A
		2AD, ADF, MSD	no	M/D	M/D
	kit	1MB, MBS, MBT, MBW, LSF, MLF, MBSxx2 (high speed)	no	M/D	M/D
third-party motor	housing or kit	asynchronous third-party motor	no	M/C	C
	housing or kit	synchronous third-party motor	no	M	C

A: automatically after drive switched on  
 D: download via commissioning tool  
 M: manual input via control master  
 C: automatic determination via drive command

Fig. 7-62: Making available values for motor parameters and motor control parameters

**Rexroth Motors** For Rexroth motors both the motor and motor control parameters are optimized by the manufacturer via the encoder data memory of the motor encoder or, for motors without encoder memory, via the commissioning tool.

**Note:** For Rexroth motors it is not required to determine the motor or motor control parameters! The commands C3200, C3600 and C4600 mustn't be started for drives with Rexroth motors because otherwise the values of motor and motor control parameters optimized by the manufacturer are overwritten with the values calculated by means of command. This can modify the drive characteristics in a disadvantageous way!

**Third-Party Motors** The commissioning of a third-party motor is similar to the commissioning of a Rexroth motor without motor encoder data memory. The major difference is that the motor and motor control parameters cannot be loaded from the motor parameter data base of the commissioning tool, but are determined by the controller via command after manual input of the type plate data and the motor parameter values (see "Third-Party Motors at IndraDrive Controllers" in chapter "Motor, Mechanical Axis System, Measuring Systems").

## Diagnostic and Status Messages

If the command execution cannot be carried out successfully, diagnostic messages will be signaling the respective errors. The description of the respective command error contains information on the causes and suggests measures for remedy. If necessary, the manufacturer-side motor data have to be questioned and the motor and motor control parameters determined again!



See descriptions of diagnostic messages in the separate documentation "Troubleshooting Guide"

## 7.6 Closed-Loop Axis Control (Closed-Loop Operation)

### Control Loop Structure

The drive controller has a cascade structure, i.e. the individual loops (position, velocity and current) are connected into one another. Depending on the operating mode there are different control loop structures with different points of input and paths of the command values. Depending on the active operating mode it is only possible to close the torque control loop, the torque and velocity control loop or additionally the position control loop in the drive. The overall structure of the control loops is illustrated below.

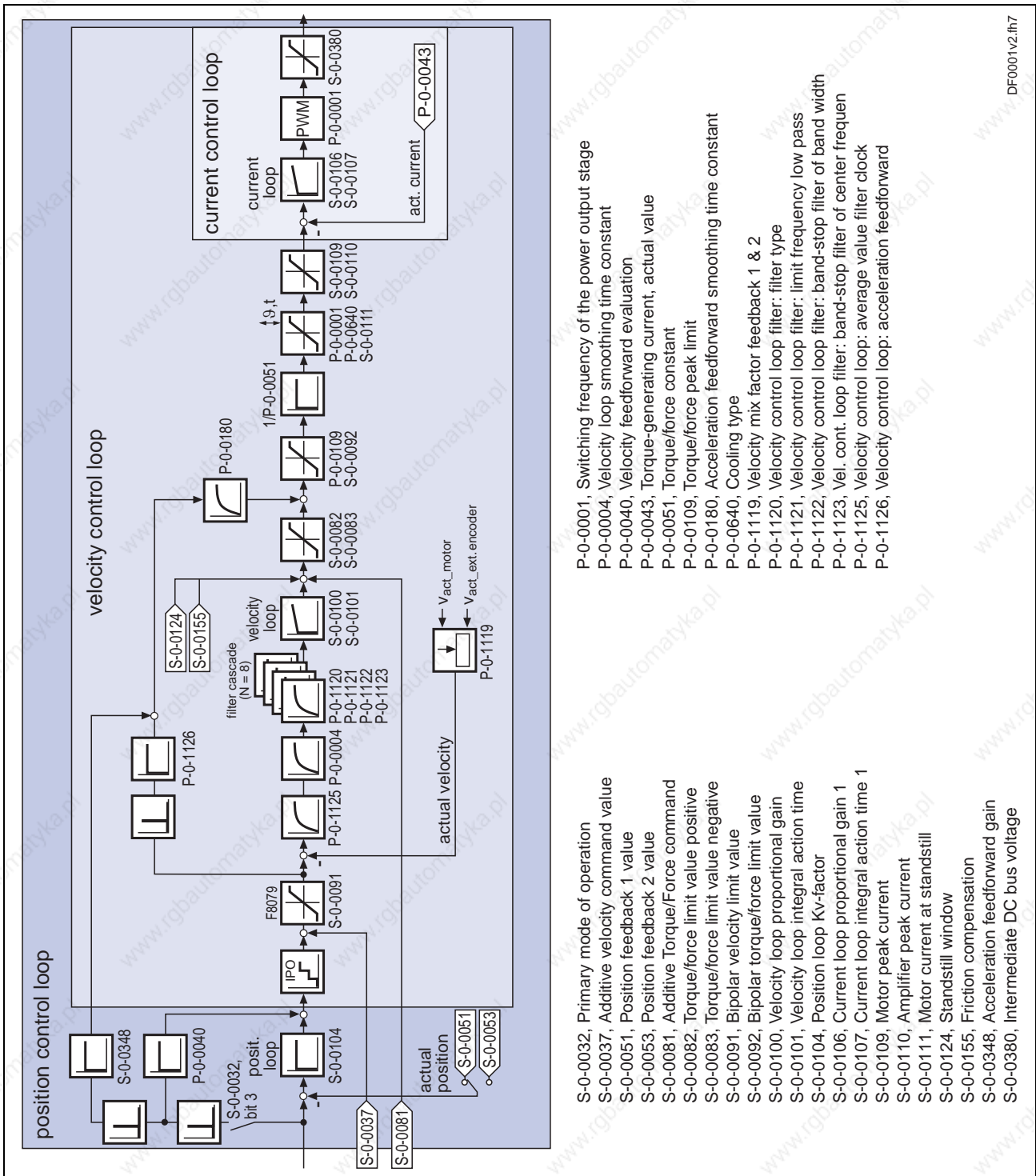

sampling times (TA) see section below  
 Fig. 7-63: Overall structure of control loop

### Features of the Control Loops

For simplifying parameterization of the control loops and increasing the capacity, some standardizations and structural modifications were made.

#### Performance (Controller Cycle Times)

The internal controller cycle times (current, velocity and position) depend on the following requirements and parameters:

- control section design (CSH, CSB or CDB)
- activation of functional packages
- P-0-0001, Switching frequency of the power output stage

- P-0-0001, Switching frequency of the power output stage
- P-0-0004, Velocity loop smoothing time constant
- P-0-0040, Velocity feedforward evaluation
- P-0-0043, Torque-generating current, actual value
- P-0-0051, Torque/force constant
- P-0-0109, Torque/force peak limit
- P-0-0180, Acceleration feedforward smoothing time constant
- P-0-0640, Cooling type
- P-0-1119, Velocity mix factor feedback 1 & 2
- P-0-1120, Velocity control loop filter: filter type
- P-0-1121, Velocity control loop filter: limit frequency low pass
- P-0-1122, Velocity control loop filter: band-stop filter of band width
- P-0-1123, Vel. cont. loop filter: band-stop filter of center frequen
- P-0-1125, Velocity control loop: average value filter clock
- P-0-1126, Velocity control loop: acceleration feedforward

- S-0-0032, Primary mode of operation
- S-0-0037, Additive velocity command value
- S-0-0051, Position feedback 1 value
- S-0-0053, Position feedback 2 value
- S-0-0081, Additive Torque/Force command
- S-0-0082, Torque/force limit value positive
- S-0-0083, Torque/force limit value negative
- S-0-0091, Bipolar velocity limit value
- S-0-0092, Bipolar torque/force limit value
- S-0-0100, Velocity loop proportional gain
- S-0-0101, Velocity loop integral action time
- S-0-0104, Position loop Kv-factor
- S-0-0106, Current loop proportional gain 1
- S-0-0107, Current loop integral action time 1
- S-0-0109, Motor peak current
- S-0-0110, Amplifier peak current
- S-0-0111, Motor current at standstill
- S-0-0124, Standstill window
- S-0-0155, Friction compensation
- S-0-0348, Acceleration feedforward gain
- S-0-0380, Intermediate DC bus voltage

DF0001v2.fh7



- **P-0-0556, Config word of axis controller** (bits 2 and 5)

With IndraDrive and ADVANCED control sections (and firmware) the following cycle and switching times can be obtained:

- PWM switching frequency    max. 16 kHz
- current loop clock             $T_{A\_current} = 62.5 \mu s$
- velocity loop clock           $T_{A\_velocity} = 125 \mu s$
- position loop clock           $T_{A\_position} = 250 \mu s$

With IndraDrive and BASIC control sections (and firmware) the following cycle and switching times can be obtained:

- PWM switching frequency    max. 8 kHz
- current loop clock             $T_{A\_current} = 125 \mu s$
- velocity loop clock           $T_{A\_velocity} = 250 \mu s$
- position loop clock           $T_{A\_position} = 500 \mu s$

---

**Note:** All data on performance are contained in section "Overview of Functions: Performance Data" in chapter "System Overview".

---

#### Position Loop

- Jerk limitation in the "cyclic position control" mode by introducing the **S-0-0349, Jerk limit bipolar** parameter. The filter degree of the smoothing filter (moving average) can be set in parameter **P-0-0042, Current position command average value filter order**.
- velocity feedforward to be set, i.e. the feedforward degree can be set via parameter **P-0-0040, Velocity feedforward evaluation** (0 % ... 100 %)
- input value for parameter **S-0-0348, Acceleration feedforward gain** can be the respective inertia in  $kg \cdot m^2$  (for rotary motor) or the mass in kg (for linear motor)

#### Velocity Loop

- Standardization of the output value at the velocity loop to Newton (N) or Newton meter (Nm). According to the motor type, there are the following units for parameter S-0-0100 for IndraDrive:
  - rotary motor             $\rightarrow Nm \cdot s/rad$
  - linear motor             $\rightarrow N \cdot min/mm$
- Extending the possibilities for filtering resonance frequencies. There are 4 filters of 2<sup>nd</sup> degree available that can be set via the parameters P-0-1120, P-0-1121, P-0-1122 and P-0-1123.
- limiting the acceleration in velocity control by setting in parameter **S-0-0138, Bipolar acceleration limit value**

### Possibilities of Accessing Outer Control Loops

It is possible to access the outer control loops when operating in a higher-level mode. Depending on the basic operating mode, the following parameters are available to do this.

In position control:

- **P-0-0059, Additive position command value, controller**
- **S-0-0037, Additive velocity command value**
- **S-0-0081, Additive torque/force command value**

In velocity control:

- **S-0-0037, Additive velocity command value**

- **S-0-0081, Additive torque/force command value**  
In current control:
- **S-0-0081, Additive torque/force command value**

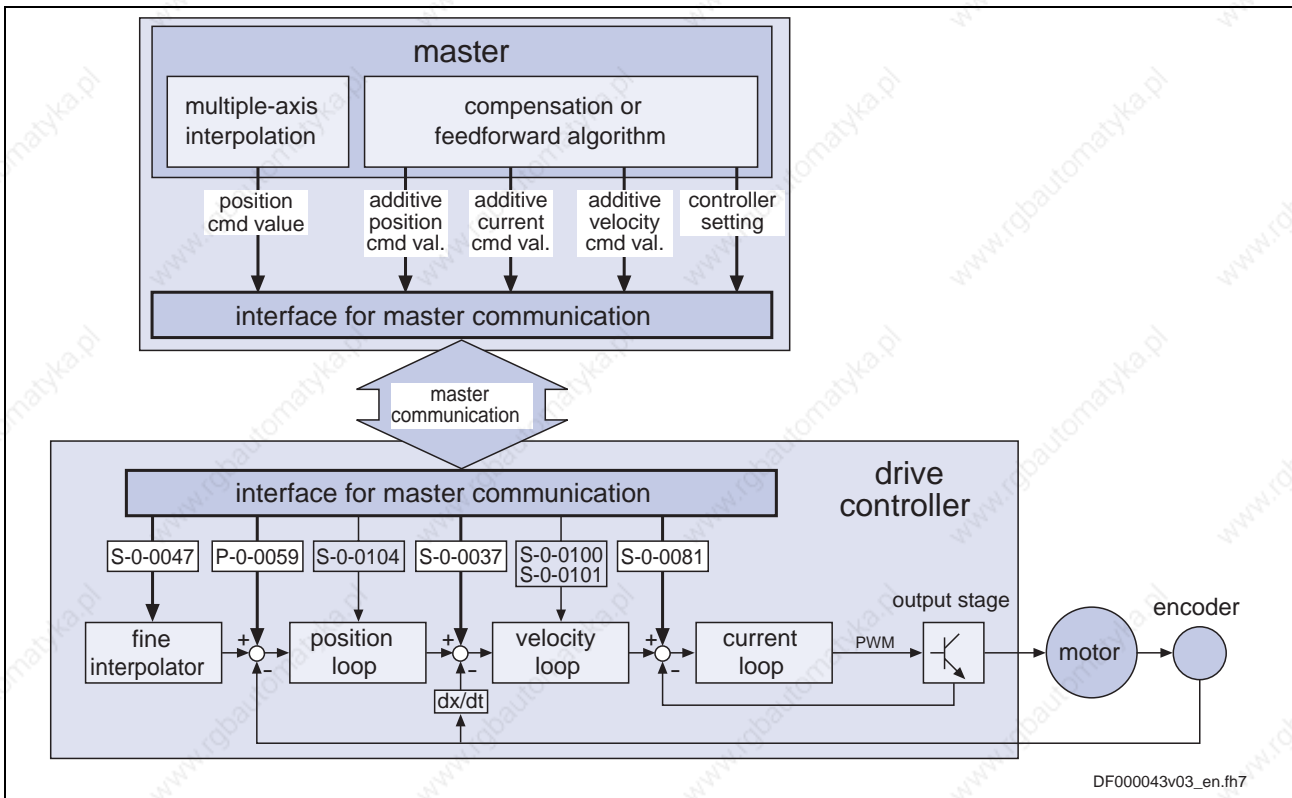

S-0-0037:	additive velocity command value
S-0-0047:	position command value
S-0-0081:	additive torque/force command value
S-0-0100:	velocity loop proportional gain
S-0-0101:	velocity loop integral action time
S-0-0104:	position loop Kv-factor
P-0-0059:	additive position command value, controller

Fig. 7-64: Structural overview (incl. possibilities of access)

## Command Value Processing Depending on Operating Mode

### Position Control

In the case of the following operating modes, the position control loop, apart from the velocity and current control loop, is closed internally (in the drive), too:

- position control with cyclic command value input
- drive-internal interpolation
- drive-controlled positioning

See also description of the respective operating mode in chapter "Operating Modes"

### Velocity Control

In the "velocity control" mode the velocity control loop, apart from the current control loop, is closed in the drive, too.

See also "Velocity Control" in chapter "Operating Modes"

### Torque/Force Control

The "torque/force control" mode actually isn't torque or force control but current control. Therefore, only the current control loop is closed in the drive.

See also "Torque/Force Control" in chapter "Operating Modes"



## Notes on Commissioning for Control Loop Setting

The control loop settings in a digital drive controller are very important for the features of the servo axis.

To optimize the control loop setting, application-specific controller parameters are available for all digital Rexroth drives.

### Order of Manual Control Loop Setting

Due to the cascade structure of the control loops it is necessary to parameterize them "from the inside to the outside". The resulting order for setting the control loops is as follows:

#### 1. Current control loop

For **Rexroth motors with motor encoder data memory** (MHD, MKD and MKE series), optimizing the current loop is not required because the corresponding parameter values (S-0-0106 and S-0-0107) are read from the motor encoder data memory.

For all **Rexroth motors without motor encoder data memory** (e.g. linear motors), the parameter settings can be taken from a central motor data base via the "IndraWorks D" commissioning tool.

The commissioning of **third-party motors** (incl. control loop setting) is described in the respective sections on third-party motors in this documentation (see "Third-Party Motors at IndraDrive Controllers" in chapter "Motor, Mechanical Axis System, Measuring Systems").

#### 2. Velocity control loop

The settings of the velocity loop (S-0-0100 and S-0-0101) with the respective filters (P-0-0004 and P-0-1120, P-0-1121, P-0-1122, P-0-1123) on the one hand depend on the motor parameters (inertia and torque/force constant), on the other hand they strongly depend on the mechanical properties (load inertia/mass, friction, stiffness of the connection, ...). Therefore, manual or automatic optimization is often required.

#### 3. Position control loop

In general, the position control loop only has to be adjusted to the dynamics of the outer velocity loop, as well as to the kind of preset command values (jerk, acceleration and interpolation procedure).

## Default Settings in the Motor Encoder Data Memory ("Load Defaults Procedure")

### S-0-0262, C07\_x Load defaults procedure command

For all Rexroth motors of the series with motor encoder data memory (e.g. MHD, MKD, MKE, MSK and possibly MAD and MAF), the basic settings for the controllers are stored and can be loaded to the drive by executing the "load defaults procedure" command (S-0-0262).

There are two ways to activate the **S-0-0262, C07\_x Load defaults procedure command** parameter:

- Automatically when running up the drive by recognizing that the motor type (cf. parameter S-0-0141) has changed. The display then reads "RL" and the "load defaults procedure" command is internally started by pressing the "Esc" button on the control panel, unless this was deactivated in **P-0-0556, Config word of axis controller**.
- Starting the command by writing "11b" to parameter S-0-0262.

See also "Loading, Storing and Saving Parameters" in chapter "Handling, Diagnostic and Service Functions"

---

**Note:** In order to start the "load defaults procedure" command the value "0" (default setting) must have been set in parameter **P-0-4090, Configuration for loading default values**.

---

During the load defaults procedure, the following control loop parameters are set to their default values optimized for the respective motor:

- **S-0-0100, Velocity loop proportional gain**
- **S-0-0101, Velocity loop integral action time**
- **S-0-0104, Position loop Kv-factor**
- **S-0-0106, Current loop proportional gain 1**
- **S-0-0107, Current loop integral action time 1**
- **P-0-0004, Velocity loop smoothing time constant**

---

**Note:** The default settings for the current loop (cf. S-0-0106 and S-0-0107) are automatically adjusted to the currently parameterized PWM frequency (cf. P-0-0001) and performance setting (cf. P-0-0556)!

---

In addition, the following control loop parameters are set to their firmware-side default values although there haven't been any default values stored for them in the motor data memory:

- **S-0-0348, Acceleration feedforward gain**
- **P-0-1125, Velocity control loop: average value filter clock**

---

**Note:** In the majority of cases, the controller settings stored in the motor encoder data memory provide a useful and reliable control loop setting. In exceptional cases, however, it may be necessary to make the settings with regard to the specific application.

---

## Automatic Setting of Axis Control

To facilitate drive parameterization, the IndraDrive firmware provides automatic control loop setting in closed-loop operation. Parameters **P-0-0163, Damping factor for autom. controller adjust** and **P-0-0164, Application for autom. controller adjust** can be used to influence the result of the control loop setting (obtained control loop dynamics).

---

**Note:** To carry out the automatic control loop setting it is necessary to move the drive. The velocity and position control loops are optimized.

---

- Features**
- definition of a travel range for movement control for the automatic control loop setting by
    - absolute travel limits
    - or -
    - entering a travel distance based on the current actual position
  - use of drive-internal interpolation and its parameters
  - possible settings in **P-0-0165, Selection for autom. controller adjust** for:
    - velocity loop
    - position loop
    - acceleration feedforward
    - determination of load inertia
    - determination of maximum acceleration

- oscillation movement/unipolar movement
- absolute travel limits/relative movement around the starting position

## 7.7 Positioning Block Mode

In the "positioning block mode" it is possible to run up to 64 programmed positioning blocks. The drive moves to the target position in position control, while maintaining velocity, acceleration, deceleration and jerk limits as defined in the respective positioning block.

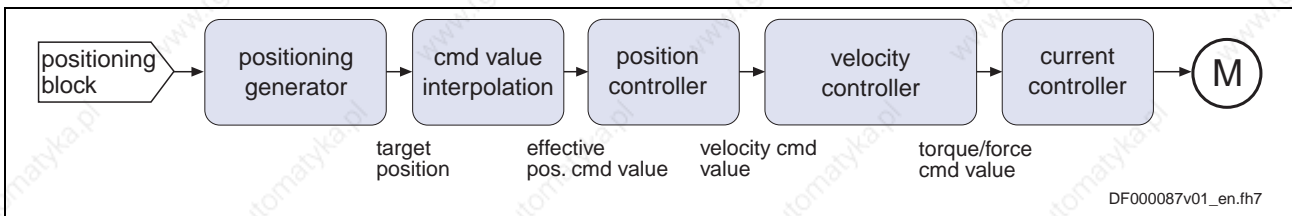

Fig. 7-65: "Positioning block mode" block diagram

### Features

- parameterization of up to 64 positioning blocks; each with target position/travel distance, velocity, acceleration, deceleration and jerk
- defined block acceptance by toggling bit 0 in S-0-0346 with reaction time  $t_{R\_Strobe} = t_{position}$

**Note:** With field bus drives, the I/O mode and control via the parallel interface are exceptions. In these cases acceptance takes place by a 0-1 edge of bit 0 in P-0-4060.

- block selection and acknowledgment via separate parameters (→ handshake principle)
- positioning modes to be freely parameterized
  - relative positioning
  - absolute Positioning
  - infinite travel (positive or negative)
- single-block or sequential block mode with different conditions for advance:
  - block advance with switch cams
  - block advance at defined position value
  - block transition with "old" or "new" positioning velocity
- positioning block transition with freely definable delay time (P-0-4018)
- positioning while taking command value mode into account (shortest distance, positive direction, ...)
- residual path processing can be activated (→ no loss of incremental dimension)
- "slow travel" mode can be activated
- velocity override to be set

### Fields of Application

Sequential block processing allows executing several positioning blocks processed in direct sequence without having to give a new start signal each time. Typical fields of application are:

- There is none or only a very simple higher-level control unit available and control is realized via digital I/Os only or a field bus control word (I/O mode with field bus interface).

- There are quick reaction times or block advances required. The required motion profiles can be represented in the drive by the maximum possible 64 positioning blocks.
- There are positioning processes required which cover long distances at high speeds (rapid traverse) and then position at the end position at low speed without any intermediate stops; for example:
  - taking up or putting down transport goods in handling robots
  - execution of joining processes in assembly facilities

## 8 Diagnostic and Service Functions

### 8.1 Diagnostic System

#### Diagnostic Status Messages

The diagnostic status messages display the phases of communication build-up and initialization (boot phase), operating states or the currently active operating mode.

---

**Note:** In the case of some diagnostic status messages the diagnostic message number contained in parameter **S-0-0390, Diagnostic message number** differs from the display at the drive controller.

---

#### Diagnostic Command Messages

Commands are used to control complex functions in the drive. The command execution is displayed in a diagnostic message.

By means of the respective parameter that is assigned to the command, a higher-level control unit can start, interrupt and clear commands. In addition, some selected commands can be directly started via the control panel of the drive controller.

There are 3 command types:

<b>Drive Control Commands</b>	Drive control commands can only be started when drive enable was set. They might possibly cause automatic drive motion and deactivate the active operating mode during its execution.
<b>Monitoring Commands</b>	Executing monitoring commands activates or deactivates monitors and functions.
<b>Administration Commands</b>	Administration commands execute administration tasks. They cannot be interrupted.

---

**Note:** Command errors are displayed with a diagnostic message, too. By means of the first three digits (Cxx) of the diagnostic message number it is possible to recognize which command caused the command error.

---

Each **command** started by a control unit must be actively cleared (see also "Basic Functions of Master Communication", "Command Processing").

A **command error** cannot be removed by "clearing errors", but only by completing the corresponding command.

#### Warnings

While in operation the drive controller carries out monitoring functions. Some monitoring functions depend on the operating mode that is used and/or parameter settings. If a status is detected that still allows correct operation but persists, which would then cause an error to be generated, a warning is generated.

---

**Note:** Some warnings won't result in an error if they are ignored.

---

**Warning Classes** Warnings can be divided into two classes:

- without drive reaction (diagnostic message numbers E1xxx .. E7xxx)
- with drive reaction (diagnostic message number E8xxx)

Warnings cannot be cleared externally.

### Warnings (E2xxx)

In the case of warnings of category E2xx, the drive normally does **not** carry out **any** drive reaction, unless the warning was generated due to a mains or undervoltage error. In this case the behavior of the drive can be determined via the parameter **P-0-0118, Power off on error**.

A second group of warnings within this category signals that a limit value determined (parameterized) by the user has been exceeded.

### Fatal Warnings (E8xxx)

In the case of warnings of category E8xxx, the drive carries out a drive reaction. In the case of warnings that were generated due to a mains or undervoltage error, the behavior of the drive can be determined via the parameter **P-0-0118, Power off on error**.

## General Description of Error Messages and Error Reactions

Depending on the operating mode that is used and some parameter settings, the drive controller carries out monitoring functions. An error message is generated by the drive controller, if a status is detected that no longer allows correct operation.

**Error Classes** Errors can be divided into several error classes. The error class is represented by the first two digits of the diagnostic message number.

Diagnostic message number	Error class	Drive reaction
F2xxx	non-fatal error	as set in <b>P-0-0119, Best possible deceleration</b>
F3xxx	non-fatal safety technology errors	as set in <b>P-0-0119, Best possible deceleration</b>
F4xxx	interface error	as set in <b>P-0-0119, Best possible deceleration</b>
F6xxx	travel range error	<b>closed Loop:</b> velocity command value reset <b>open Loop:</b> shutdown in compliance with <b>P-0-0569, Maximum stator frequency change</b>
F7xxx	safety technology error	velocity command value reset
F8xxx	fatal error	torque disable
F9xxx and E-xxxx	fatal system error	torque disable

Fig. 8-1: Error classes and drive reaction

**Note:** These Operating Instructions do not list all the errors which can occur during the operation of one of our IndraDrive controllers / supply units; the documentation "Troubleshooting Guide" contains descriptions of all possible kinds of malfunction.

## Non-Fatal Errors (F2xxx)

Non-fatal errors are errors that are still allowing a freely definable, variable error reaction.

### Drive Behavior

The user can define the drive behavior for the case of non-fatal errors occurring via the setting of the parameters **P-0-0117, Activation of NC reaction on error** and **P-0-0119, Best possible deceleration**.

### Putting the Drive into Operation

The drive can only be put into operation again when:

1. the error reaction has been completed, i.e. the drive has stopped ( $v=0!$ ).
2. the error message was cleared by the error clearing command (cf. **S-0-0099, C0500 Reset class 1 diagnostics**).
3. the cause of the error was removed.
4. drive enable was switched on again (0-1 edge).

## Interface Errors (F4xxx)

The user can influence the drive behavior in the case of interface errors by means of the parameterization of **P-0-0119, Best possible deceleration** (see also Functional Description "Error Reaction").

---

**Note:** In the case of an interface error, activating the NC reaction via **P-0-0117, Activation of NC reaction on error** is no longer possible!

---

At the end of each error reaction, the drive goes torque-free.

### Putting the Drive into Operation

The drive can only be put into operation again when:

1. the error reaction has been completed, i.e. the drive has stopped ( $v=0!$ ).
2. the error message was cleared by the error clearing command (cf. **S-0-0099, C0500 Reset class 1 diagnostics**).
3. the cause of the error was removed.
4. the drive is in the operating mode again and power was switched on ("Ab").
5. drive enable was switched on again (0-1 edge).

## Travel Range Errors (F6xxx)

Travel range errors are errors associated with exceeding a travel range previously defined via hardware or software switches; independent of the settings in **P-0-0119, Best possible deceleration** and **P-0-0117, Activation of NC reaction on error** the drive therefore is stopped as fast as can.

The kind of deceleration depends on the control mode:

- **closed-loop:** velocity command value reset
- **open-loop:** under compliance with **P-0-0569, Maximum stator frequency change**

See also Functional Description "Error Reaction"

---

**Note:** In the case of travel range errors, the settings in **P-0-0118, Power supply, configuration** still are taken into account.

---

At the end of each error reaction, the drive goes torque-free.

**Putting the Drive into Operation**

The drive can only be put into operation again when:

1. the error reaction has been completed, i.e. the drive has stopped ( $v=0!$ ).
2. the error message was cleared by the error clearing command (cf. **S-0-0099, C0500 Reset class 1 diagnostics**).
3. the cause of the error was removed.
4. the drive is in the operating mode again and power was switched on ("Ab").
5. drive enable was switched on again (0-1 edge).

**Fatal Errors (F8xxx)**

Basically there are 2 kinds of fatal errors (F8 errors):

- fatal errors during initialization (initialization errors) (e.g. F8201 and F8203, F8118, F8120, ...)
- fatal errors during operation (e.g. F8060, F8022, ...)

---

**Note:** Fatal initialization errors cannot be cleared, they require the drive to be switched off completely.

In addition to completely switching off the drive, fatal errors associated with the safety technology (e.g. F8201 and F8203) require safety technology to be completely recommissioned.

---

**Drive Behavior**

In the case of fatal errors, closed-loop control (or open-loop U/f control) of the drive is no longer ensured; with these errors the drive, independent of the setting in **P-0-0119, Best possible deceleration** and **P-0-0117, Activation of NC reaction on error**, therefore is immediately switched off, i.e. it goes torque-free (see also Functional Description "Error Reaction").

---

**Note:** In the case of fatal errors, the settings in **P-0-0118, Power supply, configuration** still are taken into account.

---

**Putting the Drive into Operation**

After a fatal error has occurred, the drive can only be commissioned again when:

1. the error message was cleared by the error clearing command (cf. **S-0-0099, C0500 Reset class 1 diagnostics**) [to do this it might possibly be necessary to switch to the parameter mode or switch the drive off completely].
2. the actual cause of the error was recognized and removed. This might possibly imply the replacement of an entire component (e.g. motor or drive controller).
3. the drive is in the operating mode again and power was switched on again ("Ab").
4. drive enable was switched on again (0-1 edge).

---

**Note:** In case fatal errors are occurring repeatedly, contact our service department as operating the drive then is no longer possible.

---



### Fatal System Errors (F9xxx and E-xxxx)

In the case of fatal system errors there is a grave problem in the drive system (e.g. watchdog error, processor crash, ...) which does no longer allow regular operation of the drive. Due to a hardware or firmware error, the drive firmware is no longer operable; clearing an error is no longer possible.

In this case the drive reacts automatically as follows:

#### Drive Behavior

- All digital outputs are set to "0".  
Safety technology: safety related feedback is deactivated!
- The "ready for operation" relay opens, this also switches power off in case the wiring is correct.
- The output stage is locked, this disables the drive torque.
- The brake output is deactivated; if a self-holding brake is used, it is applied!
- One of the following diagnostic messages is output at the display:
  - F9xxx (fatal system errors),
  - E8xxx (exceptions),
  - or E-xxxx (processor error), e.g. E-0800 (detailed information in the English language is output via the serial interface).

#### Putting the Drive into Operation

After a fatal system error has occurred, the drive can only be put into operation again when:

1. the 24 V supply is completely switched off and on so that a restart of the drive is carried out (incl. booting process and initialization).
2. the drive is run up to the operating mode again.
3. power is switched on again.

---

**Note:** In case fatal system errors are occurring repeatedly, contact our service department as operating the drive then is no longer possible.

---

## 8.2 Recommended Actions for Operating States, Activities and Reactions of the Drive Controller

The following table lists operating states, activities and reactions of the drive controller. If an error, for example, occurs during operation, take the actions in the given order until the error has been limited / cleared.

Display at comfort control panel	S-0-0095, Diagnostic message text	See documentation "Troubleshooting Guide"	Contact our sales and service facility	Contact machine manufacturer / installation programmer	Check motor incl. holding brake, battery, encoder and cooling system	Switch supply unit off and on again	Switch drive controller off and on again	Check encoder function and mounting (motor encoder and external encoder)	Check encoder cabling	Check motor cabling	Check wiring of inputs and outputs and their 24V power supply	Check connection of master communication	Check control circuit for mains connection	Check mechanical system (stiffness, loose connection,...)
P0	A0000 Communication phase 0	1												
P1	A0001 Communication phase 1	1												
P2	A0002 Communication phase 2	1												
P3	A0003 Communication phase 3	1												
P -1	A0009 Automatic baud rate detection for SERCOS interface	1												
AH	A0010 Drive HALT	1												
AS	A0011 Starting lockout active	1												
Ab	A0012 Control and power sections ready for operation	1												
bb	A0013 Ready for power on	1												
ASP	A0014 Drive interlock active	1												
SH	A0015 Safety related standstill active	1												
SBH	A0016 Safety related operational stop active	1												
SBB	A0017 Special mode motion active	1												
SBB1	A0018 Special mode motion 1 active	1												
SBB2	A0019 Special mode motion 2 active	1												
SBB3	A0020 Special mode motion 3 active	1												
SBB4	A0021 Special mode motion 4 active	1												
PM	A0050 Parameterization level 1 active	1												
AF	A0100 Torque control	1												
AF	A0101 Velocity control	1												
AF	A0102 Position mode, encoder 1	1												
AF	A0103 Position mode, encoder 2	1												
AF	A0104 Position mode lagless, encoder 1	1												
AF	A0105 Position mode lagless, encoder 2	1												
AF	A0106 Drive controlled interpolation, encoder 1	1												
AF	A0107 Drive controlled interpolation, encoder 2	1												
AF	A0108 Drive controlled interpolation, lagless, encoder 1	1												
AF	A0109 Drive controlled interpolation, lagless, encoder 2	1												
AF	A0110 Velocity synchronization, virtual master axis	1												
AF	A0111 Velocity synchronization, real master axis	1												

Display at comfort control panel	S-0-0095, Diagnostic message text	See documentation "Troubleshooting Guide"	Contact our sales and service facility	Contact machine manufacturer / installation programmer	Check motor incl. holding brake, battery, encoder and cooling system	Switch supply unit off and on again	Switch drive controller off and on again	Check encoder function and mounting (motor encoder and external encoder)	Check encoder cabling	Check motor cabling	Check wiring of inputs and outputs and their 24V power supply	Check connection of master communication	Check control circuit for mains connection	Check mechanical system (stiffness, loose connection,...)
AF	A0112 Phase synchronization, encoder 1, virtual master axis	1												
AF	A0113 Phase synchronization, encoder 2, virtual master axis	1												
AF	A0114 Phase synchronization, encoder 1, real master axis	1												
AF	A0115 Phase synchronization, encoder 2, real master axis	1												
AF	A0116 Phase synchr. lagless, encoder 1, virtual master axis	1												
AF	A0117 Phase synchr. lagless, encoder 2, virtual master axis	1												
AF	A0118 Phase synchr. lagless, encoder 1, real master axis	1												
AF	A0119 Phase synchr. lagless, encoder 2, real master axis	1												
AF	A0128 Cam shaft, encoder 1, virtual master axis	1												
AF	A0129 Cam shaft, encoder 2, virtual master axis	1												
AF	A0130 Cam shaft, encoder 1, real master axis	1												
AF	A0131 Cam shaft, encoder 2, real master axis	1												
AF	A0132 Cam shaft, lagless, encoder 1, virt. master axis	1												
AF	A0133 Cam shaft, lagless, encoder 2, virt. master axis	1												
AF	A0134 Cam shaft, lagless, encoder 1, real master axis	1												
AF	A0135 Cam shaft, lagless, encoder 2, real master axis	1												
AF	A0150 Drive-controlled positioning, encoder 1	1												
AF	A0151 Drive-controlled positioning, encoder 1, lagless	1												
AF	A0152 Drive-controlled positioning, encoder 2	1												
AF	A0153 Drive-controlled positioning, encoder 2, lagless	1												
AF	A0154 Position mode drive controlled, encoder 1	1												

Display at comfort control panel	S-0-0095, Diagnostic message text	See documentation "Troubleshooting Guide"	Contact our sales and service facility	Contact machine manufacturer / installation programmer	Check motor incl. holding brake, battery, encoder and cooling system	Switch supply unit off and on again	Switch drive controller off and on again	Check encoder function and mounting (motor encoder and external encoder)	Check encoder cabling	Check motor cabling	Check wiring of inputs and outputs and their 24V power supply	Check connection of master communication	Check control circuit for mains connection	Check mechanical system (stiffness, loose connection,...)
AF	A0155 Position mode drive controlled, encoder 2	1												
AF	A0156 Position mode lagless, encoder 1 drive controlled	1												
AF	A0157 Position mode lagless, encoder 2 drive controlled	1												
AF	A0206 Positioning block mode, encoder 1	1												
AF	A0207 Positioning block mode lagless, encoder 1	1												
AF	A0210 Positioning block mode, encoder 2	1												
AF	A0211 Positioning block mode lagless, encoder 2	1												
AC	A4000 Automatic drive check and adjustment	1												
AE	A4001 Drive deceleration to standstill	1												
AU	A4002 Drive in automatic mode	1												
C01	C0100 Communication phase 3 transition check	1												
C0101	C0101 Invalid parameters (-> S-0-0021)	1	3	2										
C0102	C0102 Limit error in parameter (-> S-0-0021)	1	3	2										
C0103	C0103 Parameter conversion error (->S-0-0021)	1	3	2										
C0104	C0104 Config. IDN for MDT not configurable	1	3	2										
C0105	C0105 Maximum length for MDT exceeded	1	3	2										
C0106	C0106 Config. IDNs for AT not configurable	1	3	2										
C0107	C0107 Maximum length for AT exceeded	1	3	2										
C0108	C0108 Time slot parameter > Sercos cycle time	1	3	2										
C0109	C0109 Position of data record in MDT (S-0-0009) even	1	3	2										
C0110	C0110 Length of MDT (S-0-0010) odd	1	3	2										
C0111	C0111 ID9 + Record length - 1 > length MDT (S-0-0010)	1	3	2										
C0112	C0112 TNcyc (S-0-0001) or TScyc (S-0-0002) error	1	3	2										
C0113	C0113 Relation TNcyc (S-0-0001) to TScyc (S-0-0002) error	1	3	2										

Display at comfort control panel	S-0-0095, Diagnostic message text	See documentation "Troubleshooting Guide"	Contact our sales and service facility	Contact machine manufacturer / installation programmer	Check motor incl. holding brake, battery, encoder and cooling system	Switch supply unit off and on again	Switch drive controller off and on again	Check encoder function and mounting (motor encoder and external encoder)	Check encoder cabling	Check motor cabling	Check wiring of inputs and outputs and their 24V power supply	Check connection of master communication	Check control circuit for mains connection	Check mechanical system (stiffness, loose connection,...)
C0114	C0114 T4 > TScyc (S-0-0002) - T4min (S-0-0005)	1	3	2										
C0115	C0115 T2 too small	1	3	2										
C0116	C0116 T3 (S-0-0008) within MDT (S-0-0089 + S-0-0010)	1	3	2										
C0119	C0119 Max. travel range too large	1	3	2										
C0120	C0120 Error when reading encoder data => motor encoder		4		2		3		1					
C0121	C0121 Incorrect parameterization of motor encoder (hardware)	1	3	2										
C0122	C0122 Incorr. parameteriz. of motor enc. (mechanical system)	1	3	2										
C0123	C0123 Modulo value for motor encoder cannot be displayed	1	3	2										
C0124	C0124 Motor encoder unknown		4		2		3		1					
C0125	C0125 Error when reading encoder data => optional encoder		4				3	2	1					
C0126	C0126 Incorrect parameterization of optional enc. (hardware)	1	3	2										
C0127	C0127 Incorr. parameteriz. of opt. enc. (mechanical system)	1	3	2										
C0128	C0128 Modulo value for optional encoder cannot be displayed	1	3	2										
C0129	C0129 Optional encoder unknown		4				3	2	1					
C0130	C0130 Maximum travel range cannot be displayed internally	1	3	2										
C0131	C0131 Switching to phase 3 impossible	1	3	2										
C0132	C0132 Invalid settings for controller cycle times	1	3	2										
C0134	C0134 Invalid motor data in encoder memory (->S-0-0021)	4	5		2		3		1					
C0135	C0135 Type of construction of motor P-0-4014 incorrect	4	5		2		3		1					
C0136	C0136 Several motor encoders connected	1	2											
C0137	C0137 Error during initialization of motor data (->S-0-0021)	4	5		2		3		1					
C0138	C0138 Invalid control section data (->S-0-0021)		2				1							
C0139	C0139 T2 (S-0-0089)+length MDT (S-0-0010)>TScyc (S-0-0002)	1	3	2										
C0140	C0140 Rotary scaling not allowed	1	3	2										

Display at comfort control panel	S-0-0095, Diagnostic message text	See documentation "Troubleshooting Guide"	Contact our sales and service facility	Contact machine manufacturer / installation programmer	Check motor incl. holding brake, battery, encoder and cooling system	Switch supply unit off and on again	Switch drive controller off and on again	Check encoder function and mounting (motor encoder and external encoder)	Check encoder cabling	Check motor cabling	Check wiring of inputs and outputs and their 24V power supply	Check connection of master communication	Check control circuit for mains connection	Check mechanical system (stiffness, loose connection,...)
C0153	C0153 Error at init. of synchr. motor with reluctance torque	1	3	2										
C0154	C0154 Field bus: IDN for cycl. command val. not configurable	1	3	2										
C0155	C0155 Field bus: max. length for cycl. command val. exceeded	1	3	2										
C0156	C0156 Field bus: IDN for cycl. actual val. not configurable	1	3	2										
C0157	C0157 Field bus: length for cycl. actual values exceeded	1	3	2										
C0158	C0158 Field bus: Tcyc (P-0-4076) incorrect	1	3	2										
C0159	C0159 Field bus: P-0-4077 missing for cycl. command values	1	3	2										
C0160	C0160 Error when reading encoder data => measuring encoder		4				3	2	1					
C0161	C0161 Incorr. parameterization of measuring enc. (hardware)	1	3	2										
C0162	C0162 Measuring encoder unknown	4	5				3	2	1					
C0163	C0163 Modulo value for measuring encoder cannot be displayed	1	3	2										
C0164	C0164 Incorrect measuring encoder configuration	1	3	2										
C0199	C0199 Functional package selection changed. Restart	2	3				1							
C02	C0200 Exit parameterization level procedure command	1												
C0201	C0201 Invalid parameters (->S-0-0423)	1	3	2										
C0202	C0202 Parameter limit error (->S-0-0423)	1	3	2										
C0203	C0203 Parameter calculation error (->S-0-0423)	1	3	2										
C0212	C0212 Invalid control section data (->S-0-0423)		2				1							
C0220	C0220 Error when initializing position of encoder 1		4		2		3		1					
C0221	C0221 Initialization velocity encoder 1 too high	1	2											
C0224	C0224 Error when initializing position of encoder 2		4				3	2	1					
C0225	C0225 Initialization velocity encoder 2 too high	1	2											
C0227	C0227 Error when initializing position of measuring encoder		4				3	2	1					

Display at comfort control panel	S-0-0095, Diagnostic message text	See documentation "Troubleshooting Guide"	Contact our sales and service facility	Contact machine manufacturer / installation programmer	Check motor incl. holding brake, battery, encoder and cooling system	Switch supply unit off and on again	Switch drive controller off and on again	Check encoder function and mounting (motor encoder and external encoder)	Check encoder cabling	Check motor cabling	Check wiring of inputs and outputs and their 24V power supply	Check connection of master communication	Check control circuit for mains connection	Check mechanical system (stiffness, loose connection,...)
C0228	C0228 Initialization velocity measuring encoder too high	1	2											
C0242	C0242 Multiple configuration of a parameter (->S-0-0423)	1	3	2										
C0243	C0243 Brake check function not possible	1	3	2										
C0244	C0244 Act. modulo value cycle greater than max. travel range	1	3	2										
C0245	C0245 Operating mode configuration (->S-0-0423) not allowed	1	3	2										
C0246	C0246 Trav. range lim. switch not ass. to dig. input	1	3	2										
C0247	C0247 Dig. output already assigned to other axis	1	3	2										
C0248	C0248 Dig. input assigned differently to axes	1	3	2										
C0249	C0249 Dig. I/Os: bit number too large	1	3	2										
C0250	C0250 Probe inputs incorrectly configured	1	3	2										
C0251	C0251 Error during synchronization to master communication		3				1				2			
C0255	C0255 Safety command for system init. incorrect	1	3	2										
C0256	C0256 Safety technology configuration error	1	3				2							
C0257	C0257 No encoder assigned to slot 1	1	3				2							
C0258	C0258 Error in relation TNcyc (S-0-0001) to fine interpol.	1	3	2										
C03	C0300 Command Set absolute measuring	1												
C0301	C0301 Measuring system unavailable	1	3	2										
C0302	C0302 Absolute evaluation of measuring system impossible	1	3	2										
C0303	C0303 Absolute encoder offset cannot be saved	4	5		2		3	2	1					
C04	C0400 Activate parameterization level 1 procedure command	1												
C0401	C0401 Drive active, switching not allowed	1	2											
C0403	C0403 Switching to CCD phase 2 impossible													
C05	C0500 Reset class 1 diagnostics, error reset	1												

Display at comfort control panel	S-0-0095, Diagnostic message text	See documentation "Troubleshooting Guide"	Contact our sales and service facility	Contact machine manufacturer / installation programmer	Check motor incl. holding brake, battery, encoder and cooling system	Switch supply unit off and on again	Switch drive controller off and on again	Check encoder function and mounting (motor encoder and external encoder)	Check encoder cabling	Check motor cabling	Check wiring of inputs and outputs and their 24V power supply	Check connection of master communication	Check control circuit for mains connection	Check mechanical system (stiffness, loose connection,...)
C0501	C0501 Error clearing only in parameter mode	1	2											
C06	C0600 Drive-controlled homing procedure command	1												
C0601	C0601 Homing only possible with drive enable	1	3	2										
C0602	C0602 Distance home switch - reference mark erroneous	1	3	2										
C0604	C0604 Homing of absolute encoder not possible	1	3	2										
C0606	C0606 Reference mark not detected	4	5		2		3	2	1					
C0607	C0607 Home switch input not assigned	1	3	2										
C0702	C0702 Default parameters not available	1	2											
C0703	C0703 Default parameters invalid		3		2				1					
C0704	C0704 Parameters not copyable		1											
C0706	C0706 Error when reading the controller parameters		4		3		1		2					
C0722	C0722 Parameter default value incorrect (-> S-0-0423)	1	2											
C0723	C0723 Safety command for load defaults procedure incorrect	1	3				2							
C0724	C0724 Timeout of safety command for load defaults procedure	1	3				2							
C0751	C0751 Parameter default value incorrect (-> S-0-0423)	1	2											
C0752	C0752 Locked with password	1	3	2										
C0799	C0799 An invalid index was set	1	2											
C09	C0900 Position spindle command	1												
C0902	C0902 Spindle positioning requires drive enable	1	3	2										
C0903	C0903 Error during initialization	1	3	2										
C0906	C0906 Error during search for zero pulse	2	4	3					1					
C12	C1200 Commutation offset setting command	1												
C1204	C1204 Error in offset calculation		1											
C1208	C1208 No adjustment with asynchronous motor	1	2											
C1209	C1209 Proceed to phase 4	1	2											
C1214	C1214 Command only possible with linear synchronous motor	1	2											
C1215	C1215 Command only possible in 'bb'	1	2											



Display at comfort control panel	S-0-0095, Diagnostic message text	See documentation "Troubleshooting Guide"	Contact our sales and service facility	Contact machine manufacturer / installation programmer	Check motor incl. holding brake, battery, encoder and cooling system	Switch supply unit off and on again	Switch drive controller off and on again	Check encoder function and mounting (motor encoder and external encoder))	Check encoder cabling	Check motor cabling	Check wiring of inputs and outputs and their 24V power supply	Check connection of master communication	Check control circuit for mains connection	Check mechanical system (stiffness, loose connection,...)
C1216	C1216 Commutation determination not selected	1	2											
C1217	C1217 Setting only possible in 'Ab'	1	2											
C1218	C1218 Automatic commutation: current too low	1	2											
C1219	C1219 Automatic commutation: overcurrent	1	2											
C1220	C1220 Automatic commutation: timeout	2	3				1							
C1221	C1221 Automatic commutation: iteration without result	3	4		2			1						
C1222	C1222 Error when writing offset parameters	4	5		2			2	1					
C13	C1300 Positive stop drive procedure command	1												
C1301	C1301 Class 1 diagnostics error at command start	1	2											
C14	C1400 Command Get marker position	1												
C17	C1700 Command measuring wheel mode	1												
C1701	C1701 Measuring wheel mode not possible	1	2											
C18	C1800 Command automatic control loop setting	1												
C1801	C1801 Start requires drive enable	1	2											
C1802	C1802 Motor feedback data not valid	2	3		1									
C1803	C1803 Inertia detection failed	1	2											
C1804	C1804 Automatic controller setting failed	1	2											
C1805	C1805 Travel range invalid	1	2											
C1806	C1806 Travel range exceeded	1	2											
C1807	C1807 Determining travel range only via travel distance	1	2											
C20	C2000 Command Release motor holding brake	1												
C2001	C2001 Command not enabled	1	2											
C21	C2100 Brake check command	1												
C2101	C2101 Brake check only possible with drive enable	1	2											
C2103	C2103 Brake torque too low	1	3		2									
C2104	C2104 Command execution not possible	1	2											
C22	C2200 Backup working memory procedure command	1												

Display at comfort control panel	S-0-0095, Diagnostic message text	See documentation "Troubleshooting Guide"	Contact our sales and service facility	Contact machine manufacturer / installation programmer	Check motor incl. holding brake, battery, encoder and cooling system	Switch supply unit off and on again	Switch drive controller off and on again	Check encoder function and mounting (motor encoder and external encoder)	Check encoder cabling	Check motor cabling	Check wiring of inputs and outputs and their 24V power supply	Check connection of master communication	Check control circuit for mains connection	Check mechanical system (stiffness, loose connection,...)
C2202	C2202 Error when writing data to non-volatile memory	1	2											
C23	C2300 Load working memory command	1												
C2301	C2301 Error when reading non-volatile memory	1	2											
C2302	C2302 Error when converting parameters	1	2											
C24	C2400 Selectively backup working memory procedure command	1	2											
C2402	C2402 Error when saving parameters	1	2											
C25	C2500 Copy IDN from optional memory to internal memory	1												
C2502	C2502 Error when accessing the MMC	1	2											
C2504	C2504 Error when writing data to internal memory	1	2											
C26	C2600 Copy IDN from internal memory to optional memory	1	2											
C2602	C2602 Error when accessing the MMC	1	2											
C2604	C2604 Error when reading the internal memory	1	2											
C28	C2800 Analog input adjust command	1												
C2801	C2801 Analog input not configured													
C2802	C2802 Oscillations of input signal outside tolerance range	1	2											
C2803	C2803 Measured values at zero point and max. value identical	1	2											
C2804	C2804 Automatic adjust failed	1	2											
C29	C2900 Command Firmware update from MMC	1												
C2903	C2903 Error when accessing the MMC	1	2											
C2904	C2904 Error when accessing the flash	2	3				1							
C2905	C2905 Programmed firmware defective	1	2											
C31	C3100 Recalculate actual value cycle	1												
C3101	C3101 Act. modulo value cycle greater than max. travel range	1	3	2										
C3102	C3102 Drive is still in drive enable	1	2											
C32	C3200 Command Calculate motor data	1												
C3201	C3201 Incorrect input for current	1	3	2										
C3202	C3203 Incorrect input for voltage	1	3	2										
C3203	C3202 Incorrect input for frequency	1	3	2										
C3204	C3204 Incorrect input for speed	1	3	2										

Display at comfort control panel	S-0-0095, Diagnostic message text	See documentation "Troubleshooting Guide"	Contact our sales and service facility	Contact machine manufacturer / installation programmer	Check motor incl. holding brake, battery, encoder and cooling system	Switch supply unit off and on again	Switch drive controller off and on again	Check encoder function and mounting (motor encoder and external encoder)	Check encoder cabling	Check motor cabling	Check wiring of inputs and outputs and their 24V power supply	Check connection of master communication	Check control circuit for mains connection	Check mechanical system (stiffness, loose connection,...)
C3205	C3205 Incorrect input for power factor	1	3	2										
C3206	C3206 Incorrect input for power	1	3	2										
C3207	C3207 Type plate list incomplete	1	3	2										
C3208	C3208 Error when writing parameters	1	2											
C33	C3300 Set coordinate system procedure command	1												
C34	C3400 Shift coordinate system procedure command	1												
C35	C3500 Command Determine encoder correction values	1												
C3501	C3501 Acquisition velocity not allowed	1	3	2										
C3502	C3502 Motor encoder not available	1	3	2										
C3503	C3503 Optional encoder not available	1	3	2										
C3504	C3504 Measuring encoder not available	1	3	2										
C3505	C3505 No encoder selected	1	3	2										
C3506	C3506 Correction value table cannot be stored	1	2											
C38	C3800 Command Apply motor holding brake	1												
C39	C3900 Command Abrasion of brake	1												
C3901	C3901 Abrasion of brake only possible with drive enable	1	2											
C3902	C3902 Error during abrasion of brake	1	2											2
C3903	C3903 Command execution impossible	1	3	2										
E-XXXX	E-0000 Processor exception error		1											
E2011	E2011 PLC - Warning no. 1			1										
E2012	E2012 PLC - Warning no. 2			1										
E2013	E2013 PLC - Warning no. 3			1										
E2014	E2014 PLC - Warning no. 4			1										
E2021	E2021 Motor temperature outside of measuring range	1												
E2026	E2026 Undervoltage in power section	1	4			3							2	
E2040	E2040 Device overtemperature 2 prewarning		3				2							1
E2047	E2047 Interpolation velocity = 0	1	3	2										
E2048	E2048 Interpolation acceleration = 0	1	3	2										
E2049	E2049 Positioning velocity >= limit value	1	3	2										
E2050	E2050 Device overtemp. Prewarning		3				2							1

Display at comfort control panel	S-0-0095, Diagnostic message text	See documentation "Troubleshooting Guide"	Contact our sales and service facility	Contact machine manufacturer / installation programmer	Check motor incl. holding brake, battery, encoder and cooling system	Switch supply unit off and on again	Switch drive controller off and on again	Check encoder function and mounting (motor encoder and external encoder)	Check encoder cabling	Check motor cabling	Check wiring of inputs and outputs and their 24V power supply	Check connection of master communication	Check control circuit for mains connection	Check mechanical system (stiffness, loose connection,...)
E2051	E2051 Motor overtemp. prewarning	3	4		2									1
E2053	E2053 Target position out of travel range	1	3	2										
E2054	E2054 Not homed	1	3	2										
E2055	E2055 Feedrate override S-0-0108 = 0	1	3	2										
E2056	E2056 Torque limit = 0	1	3	2										
E2058	E2058 Selected process block is not programmed.	1	3	2										
E2061	E2061 Device overload prewarning		3	2										1
E2063	E2063 Velocity command value > limit value	1	3	2										
E2064	E2064 Target position out of num. range		1											
E2069	E2069 Brake torque too low	1	3		2									
E2074	E2074 Encoder 1: encoder signals disturbed		3		2				1					
E2075	E2075 Encoder 2: encoder signals disturbed		3					2	1					
E2076	E2076 Measuring encoder: encoder signals disturbed		3					2	1					
E2086	E2086 Prewarning supply module overload		4			3				2				1
E2802	E2802 HW control of braking resistor		2										1	
E2810	E2810 Drive system not ready for operation	1	2											
E2814	E2814 Undervoltage in mains		2										1	
E2815	E2815 Overvoltage in mains													
E2816	E2816 Undervoltage in power section		2										1	
E2818	E2818 Phase failure													
E2819	E2819 Mains failure		2										1	
E2820	E2820 Braking resistor overload prewarning		2											1
E2829	E2829 Not ready for power on		3								2		1	
E3110	E3110 Time interval of forced dynamization exceeded	2	4	3							1			
E8025	E8025 Overvoltage in power section		3										1	2
E8026	E8026 Undervoltage in power section													
E8028	E8028 Overcurrent in power section		4		2		3			1				
E8029	E8029 Positive position limit exceeded	1	3	2										
E8030	E8030 Negative position limit exceeded	1	3	2										
E8034	E8034 Emergency-Stop	2	3								1			

Display at comfort control panel	S-0-0095, Diagnostic message text	See documentation "Troubleshooting Guide"	Contact our sales and service facility	Contact machine manufacturer / installation programmer	Check motor incl. holding brake, battery, encoder and cooling system	Switch supply unit off and on again	Switch drive controller off and on again	Check encoder function and mounting (motor encoder and external encoder)	Check encoder cabling	Check motor cabling	Check wiring of inputs and outputs and their 24V power supply	Check connection of master communication	Check control circuit for mains connection	Check mechanical system (stiffness, loose connection,...)
E8040	E8040 Torque/force actual value limit active		2											1
E8041	E8041 Current limit active		4		2		3			1				
E8043	E8043 Positive travel range limit switch activated		2								1			
E8044	E8044 Negative travel range limit switch activated		2								1			
E8055	E8055 Motor overload, current limit active		5		3		4			2				1
E8057	E8057 Device overload, current limit active		5		3		4			2				1
E8058	E8058 Drive system not ready for operation	1	2											
E8260	E8260 Torque/force command value limit active		2											1
F2005	F2005 Cam shaft invalid	1	3	2										
F2006	F2006 MMC was removed	1	2											
F2007	F2007 Switching to non-initialized operating mode	1	3	2										
RL	F2008 RL The motor type has changed.	1												
PL	F2009 PL Load parameter default values	1												
F2010	F2010 Error when initializing digital inputs/outputs	1	3	2										
F2011	F2011 PLC - Error nr. 1		2	1										
F2012	F2012 PLC - Error nr. 2		2	1										
F2013	F2013 PLC - Error nr. 3		2	1										
F2014	F2014 PLC - Error nr. 4		2	1										
F2018	F2018 Device overtemperature shutdown		3				2							1
F2019	F2019 Motor overtemperature shutdown		5		3		4			2				1
F2021	F2021 Motor temperature monitor defective		4		2		3			1				
F2022	F2022 Device temperature monitor defective		2				1							
F2026	F2026 Undervoltage in power section	1	4			3							2	
F2028	F2028 Excessive deviation	2	3											1
F2031	F2031 Encoder 1 error: signal amplitude incorrect													
F2032	F2032 Validation error during commutation fine adjust	3	4							2				1
F2033	F2033 External power supply X10 error	2	3								1			
F2036	F2036 Excessive position feedback difference	2	5		4			3	1					

Display at comfort control panel	S-0-0095, Diagnostic message text	See documentation "Troubleshooting Guide"	Contact our sales and service facility	Contact machine manufacturer / installation programmer	Check motor incl. holding brake, battery, encoder and cooling system	Switch supply unit off and on again	Switch drive controller off and on again	Check encoder function and mounting (motor encoder and external encoder)	Check encoder cabling	Check motor cabling	Check wiring of inputs and outputs and their 24V power supply	Check connection of master communication	Check control circuit for mains connection	Check mechanical system (stiffness, loose connection,...)
F2037	F2037 Excessive position command difference	1	3	2										
F2039	F2039 Maximum acceleration exceeded	2	4	3										1
F2040	F2040 Device overtemperature 2 shutdown		3				2							1
F2042	F2042 Encoder 2: encoder signals incorrect		4				3	2	1					
F2043	F2043 Measuring encoder: encoder signals incorrect		4				3	2	1					
F2044	F2044 External power supply X15 error	2	3								1			
F2048	F2048 Low battery voltage	2	3		1									
F2050	F2050 Overflow of target position preset memory	1	3	2										
F2051	F2051 No sequential block in target position preset memory	1	3	2										
F2053	F2053 Incr. encoder emulator: pulse frequency too high		2	1										
F2054	F2054 Incr. encoder emulator: hardware fault	1	3	2										
F2067	F2067 Synchronization to master communication incorrect		2									1		
F2069	F2069 Error when releasing the motor holding brake		4		3						2			1
F2074	F2074 Actual pos. value 1 outside absolute encoder window	1	4		3				2					
F2075	F2075 Actual pos. value 2 outside absolute encoder window	1	4					3	2					
F2076	F2076 Actual pos. value 3 outside absolute encoder window	1	4					3	2					
F2077	F2077 Current measurement trim wrong		2				1							
F2086	F2086 Error supply module	1	3			2								
F2087	F2087 Module group communication error		2								1			
F2100	F2100 Incorrect access to command value memory		2				1							
F2101	F2101 It was impossible to address MMC	1	2											
F2102	F2102 It was impossible to address I2C memory	1	2											
F2103	F2103 It was impossible to address EnDat memory	1	2											
F2104	F2104 Commutation offset invalid	3	4					2	1					

Display at comfort control panel	S-0-0095, Diagnostic message text	See documentation "Troubleshooting Guide"	Contact our sales and service facility	Contact machine manufacturer / installation programmer	Check motor incl. holding brake, battery, encoder and cooling system	Switch supply unit off and on again	Switch drive controller off and on again	Check encoder function and mounting (motor encoder and external encoder)	Check encoder cabling	Check motor cabling	Check wiring of inputs and outputs and their 24V power supply	Check connection of master communication	Check control circuit for mains connection	Check mechanical system (stiffness, loose connection,...)
F2110	F2110 Error in non-cyclical data communic. of power section		2				1							
F2174	F2174 Loss of motor encoder reference	1	4		3				2					
F2175	F2175 Loss of optional encoder reference	1	4					3	2					
F2176	F2176 Loss of measuring encoder reference	1	4					3	2					
F2177	F2177 Modulo limitation error of motor encoder		1											
F2178	F2178 Modulo limitation error of optional encoder		1											
F2179	F2179 Modulo limitation error of measuring encoder		1											
F2816	F2816 Softstart fault power supply unit		2			1								
F2819	F2819 Mains failure		3			2							1	
F2820	F2820 Braking resistor overload		3			2								1
F2821	F2821 Error in control of braking resistor		3			2				1				
F2825	F2825 Switch-on threshold braking resistor too low	1	2											
F2836	F2836 DC bus balancing monitor error		4		2	3				1				
F4001	F4001 Double MST failure shutdown	3	4				2					1		
F4002	F4002 Double MDT failure shutdown	2	4				3					1		
F4003	F4003 Invalid communication phase shutdown	1	3	2										
F4004	F4004 Error during phase progression	1	3	2										
F4005	F4005 Error during phase regression	1	3	2										
F4006	F4006 Phase switching without ready signal	1	3	2										
F4009	F4009 Bus failure	3	4				2					1		
F4012	F4012 Incorrect I/O length	1	3	2										
F4014	F4014 PLC watchdog		2				1							
F4034	F4034 Emergency-Stop	2	4	3							1			
F6024	F6024 Maximum braking time exceeded	2	3											1
F6029	F6029 Positive travel limit exceeded	1	3	2										
F6030	F6030 Negative travel limit exceeded	1	3	2										
F6034	F6034 Emergency-Stop	2	4	3							1			
F6043	F6043 Positive travel range limit switch activated	1	4	3							2			
F6044	F6044 Negative travel range limit switch activated	1	4	3							2			
F8xxx	F8000 Fatal hardware error	1												

Display at comfort control panel	S-0-0095, Diagnostic message text	See documentation "Troubleshooting Guide"	Contact our sales and service facility	Contact machine manufacturer / installation programmer	Check motor incl. holding brake, battery, encoder and cooling system	Switch supply unit off and on again	Switch drive controller off and on again	Check encoder function and mounting (motor encoder and external encoder)	Check encoder cabling	Check motor cabling	Check wiring of inputs and outputs and their 24V power supply	Check connection of master communication	Check control circuit for mains connection	Check mechanical system (stiffness, loose connection,...)
F8013	F8013 Automatic commutation: current too low	2	3											1
F8014	F8014 Automatic commutation: overcurrent	1	2											
F8015	F8015 Automatic commutation: timeout	2	3				1							
F8016	F8016 Automatic commutation: iteration without result	3	4		2			1						
F8022	F8022 Enc. 1: enc. signals incorr. (can be cleared in ph. 2)		4		2		3		1					
F8023	F8023 Error mechanical link of encoder or motor connection	3	4		2				1					
F8027	F8027 Safety related standstill while drive enabled	1	3								2			
F8060	F8060 Overcurrent in power section		5		2		3			1				4
F8064	F8064 Interruption of motor phase	2	3							1				
F8070	F8070 +24Volt DC error		2								1			
F8078	F8078 Speed loop error		6		4		5		2	1				3
F8079	F8079 Velocity limit value exceeded	1	3	2										
F8091	F8091 Power section defective		3			2	1							
F8100	F8100 Error when initializing the parameter handling		2				1							
F8102	F8102 Error when initializing power section		2				1							
F8118	F8118 Invalid power section/firmware combination	1	2											
F8120	F8120 Invalid control section/firmware combination	1	2											
F8122	F8122 Control section defective		2				1							
F8129	F8129 Incorrect optional module firmware	1	3				2							
F8130	F8130 Firmware of option 2 of safety technology defective	1	3				2							
F8838	F8838 Overcurrent external braking resistor		2			3								1
F9001	F9001 Error internal function call		1											
F9002	F9002 Error internal RTOS function call		1											
F9003	F9003 Watchdog		1											



## 8.3 Troubleshooting

### Check Drive Components

#### Motor

- brake
- battery of encoder
- cooling system
- cable

#### Supply Unit

- wiring
- 24V supply voltage
- mains voltage 3 \* 400V

#### Drive Controller

- note down error number
- wiring
- 24V supply voltage
- mains voltage 3 \* 400V

#### Encoder

- You can check the encoder signals by means of the oscilloscope function of the firmware

#### Cables

- encoder cable
- motor cable
- input and output cables incl. 24V supply voltage
- cables of the master communication

#### Peripheral Equipment

- mains connection / switch-on logic
- mechanics (rough running, loose connections, ...)
- transition resistances within the emergency circuit

### Replacing Devices

---

**Note:** For replacing devices you absolutely have to observe the safety instructions contained in chapter 3!

---

#### Replacing the Motor

- Eventually note down the last absolute value.
- open main switch
- make sure main switch cannot be switched on again
- disconnect plug-in connectors

---

**Note:** When replacing the motor, cover the open mating sites of power lines with protective caps if sprinkling with cooling liquid/lubricant or soiling may occur (allowed degree of soiling according to EN50178: 2).

---

- replace motor
- 

**Note:** To mechanically replace the AC servo motor, observe the instructions of the machine manufacturer.

---

- connect plug-in connectors
- 



**WARNING**

**Risk of accident due to accidental axis movement!**

⇒ Servo axes with indirect distance measuring system via the motor encoder will lose the position data reference when the motor is replaced! This position data reference to the machine coordinate system must therefore be reestablished after replacement.

---

- for servo axes with absolute motor encoder, reestablish the position data reference

### Replacing the Supply Unit

---

**Note:** Replacing the unit requires, depending upon unit weight, a lifting device and an identical replacement unit.

---



**DANGER**

**Electrical shock due to voltage-containing parts of more than 50 V!**

⇒ The unit may only be replaced by qualified personnel, which have been trained to perform the work on or with electrical devices.

---

**Note:** Prior to the replacement of the unit please check according to the type plates, whether these units are of the same types. Replace only units of the same types.

---

Proceed as follows:

1. Switch voltage to installation off and secure it against being switched back on.
2. Using an appropriate measuring device, check whether the installation is power free. Wait the discharge time.
3. Motors must be standing still.
4. Secure vertical axes against motion.
5. Release all connections from the defective unit.
6. Release the fixing bolts and remove the unit from the control cabinet. Use the lifting device, if necessary.
7. Hang replacement unit into mounting rails. Use the lifting device, if necessary.

8. Reconnect the unit as per the terminal diagram of the machine manufacturer.
9. If vertical axes have been mechanically secured prior to replacement, then remove these devices at this point.
10. While reading out the fault memories of the connected drive controllers make sure that the device fault has not been triggered by the drive controllers.

The unit replacement is completed. The system can be put back into operation.

### Replacing the Drive Controller

- save parameter set
- open main switch
- make sure main switch cannot be switched on again
- make sure drive controller is completely de-energized



**DANGER**

#### Lethal electric shock caused by contact to live parts!

⇒ Before touching live parts allow the capacitors to discharge! Only then start working on the connection cables!

- remove touch guard and separate connecting lines from drive controller
- unscrew screws on top and bottom of housing
- take drive controller out of drive system
- mount new drive controller
- connect new drive controller as specified in machine circuit diagram
- mount touch guard
- copy firmware and parameter set to new drive controller (see firmware documentation)

## Cables

### Replacing Cables



**WARNING**

#### Lethal electric shock caused by live parts with more than 50 V!

⇒ Power connectors of the cables may only be separated or connected if the installation has been de-energized!

**Note:** When replacing cables, observe the instructions of the machine manufacturer.

If you do not use ready-made Rexroth cables, check to ensure that the cables match the terminal diagram of the machine manufacturer!

- open main switch
- make sure main switch cannot be switched on again
- disconnect plug-in connectors

---

**Note:** When replacing cables, cover the open mating sites of power lines with protective caps if sprinkling with cooling liquid/lubricant or soiling may occur (allowed degree of soiling according to EN50178: 2).

---

- replace cable
- 



CAUTION

### Property damage caused by bad power connectors!

⇒ Only separate or connect clean and dry power connectors.

---

- connect plug-in connectors

## Replacing the Firmware

### Basic Principles

#### Explanation of Terms

For firmware replacement we distinguish the following cases:

- **Release** **update**  
An old firmware release (e.g. MPH04V06) contained in the device is replaced by a new firmware release (e.g. MPH04V08).
  - **Version** **upgrade**  
The old firmware version (e.g. MPH03V20) contained in the device is replaced by a new firmware version (e.g. MPH04V08).
- 

**Note:** The paragraphs below describe the recommended options of firmware replacement by higher releases ("update") or versions ("upgrade"). The same conditions and sequences of actions apply to firmware replacement by older releases or older firmware versions.

---

Firmware for IndraDrive is replaced using the following hardware and software:

- **MultiMediaCard (MMC)**
  - **PC with software "IndraWorks D"**
- 

**Note:** The commissioning software "IndraWorks D" can be ordered from one of our sales and service facilities under the designation SWA-IWORKS-D\*\*-03VRS-D0-CD650-COPY (part no. R911312495). The scope of supply of "IndraWorks D" contains a documentation which describes the operation of the program.

---

### Preparations and Conditions for Firmware Replacement

#### Preparing the Firmware Replacement

You have to make the following preparations for firmware replacement:

1. Drive controller must be on (24 V supply).
2. Be absolutely sure to save parameter values before any firmware version upgrade (for release update this is recommended).  
See section "Loading, Storing and Saving Parameters"
3. Drive controller **mustn't** be in operating mode (communication phase 4) [cf. P-0-0115].

**General Notes on How to Carry Out Firmware Replacement**

You have to observe the following points when carrying out the firmware replacement:

- Do not switch off the 24 V control voltage while replacing the firmware.
- Firmware replacement always must be carried out completely, i.e. firmware on optional safety technology module must be replaced, too.
- For firmware replacement we distinguish between **release update** and **version upgrade**.

---

**Note:** When firmware is replaced in conjunction with the option starting lockout ("L1"), this does not require any specific measure, i.e. the additional measures described below only apply to the use of option "S1"!

---

## Firmware Release Update

When firmware in a drive controller is replaced by firmware of a **new release**, this is called firmware release update (e.g. FWA-INDRV\*-MPH-04V06-D5 replaced by FWA-INDRV\*-MPH-04V08-D5).

The described sequences of the firmware release update depend on the configuration of the control section and the hardware (MMC or PC) used for update. The basically recommended sequence of the firmware release update is illustrated in the scheme below:

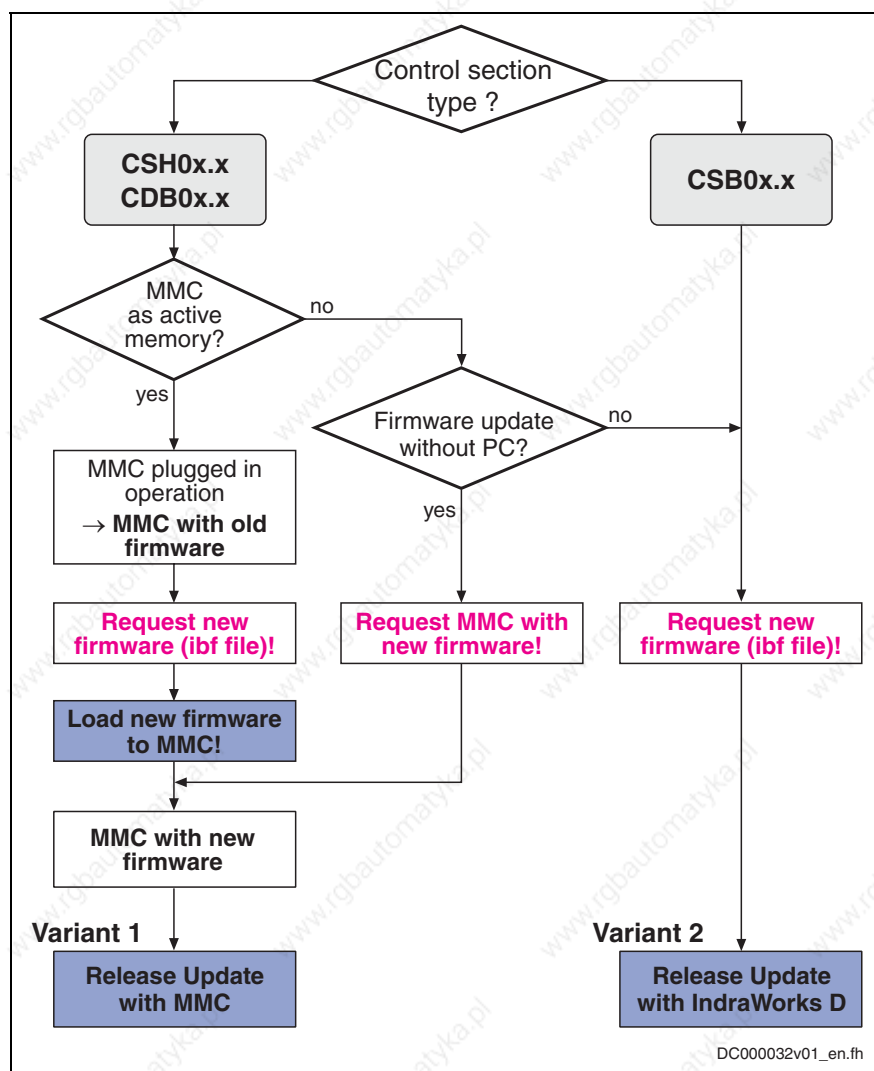

CSH0x.x:       ADVANCED single-axis control section  
 CDB0x.x:       BASIC double-axis control section  
 CSB0x.x:       BASIC single-axis control section  
 active memory: "programming module" operation of MMC (see P-0-4065)

Fig. 8-2: Schematic sequence of firmware release update

**Note:** The action instructions marked with dark background in the illustration are described in the paragraphs below.

## Loading New Firmware to MMC

### Requirements

The following requirements must have been fulfilled for loading firmware to the MMC of the drive:

- new firmware available (ibf file)
- PC with MMC reader
- MMC with old firmware in drive

### Loading Firmware to MMC

The following steps are required for loading the firmware to the MMC:

1. Switch drive off and remove MMC.
2. Plug MMC into MMC reader and open folder "Firmware" on MMC.
3. Delete old firmware (e.g. FWA-INDRV\_-MPH-04V06-D5.ibf).
4. Copy new firmware (e.g. FWA-INDRV\_-MPH-04V08-D5.ibf) to folder "Firmware".

---

**Note:** Only one firmware file may be stored in the folder "Firmware" on the MMC. With several firmware files, the message "MMC not correct" appears on the display of the drive after booting.

---

5. Remove MMC from MMC reader after writing process has been completed.

### Variant 1: Release Update with MMC

#### Selection Criterion

Carrying out the firmware release update with MMC makes sense when the controller has **not** been equipped with a BASIC single-axis control section.

#### Firmware Update with MMC

The optional MultiMediaCard (MMC) allows transmitting drive firmware to the drive controller in a quick and uncomplicated way.

---

**Note:** As the MMC is a storage medium that can be written in a simple way (e.g. via PC), it is recommended that you check the MMC content before downloading the firmware. You have to make sure that the MMC really contains the appropriate firmware type.

---

An MMC with the current release of the required firmware can be ordered from one of our sales and service facilities.

Carrying out the firmware release update with MMC requires the following steps:

#### 1. Load firmware

- ⇒ Switch drive off.
- ⇒ Plug MMC with new firmware into corresponding slot at controller.
- ⇒ Restart drive with MMC plugged.

After drive has been booted, the following message appears:

- "Firmware update?"

- ⇒ Acknowledge this message by pressing "Enter" key of control panel. By doing this, firmware is loaded from plugged MMC to controller.

If drive **before firmware replacement** was operated **without MMC plugged**, the following message appears:

- "Load new param.?"

→ Switch drive off, remove MMC and restart drive.

#### 2. Put machine into ready-for-operation status

- ⇒ Put machine into ready-for-operation status again according to machine manufacturer's instructions.
- ⇒ Check functions of drive.

### 3. Check safety technology parameters (only when safety technology has been activated in drive)

In the case of a release update, safety technology parameters are retained. With safety technology activated, the following steps are additionally required:

⇒ Check whether correct safety technology parameters for drive are still available.

To do this, check the following points:

- data in **P-0-3205, Safety technology device identifier**
- status of safety technology via **P-0-3207, Safety technology password level** (in the case of active and locked safety technology, level is 2)
- change counter of safety technology memory (**P-0-3201, Change counter of safety technology memory**)
- operating hours at last change of memory (**P-0-3202, Operating hours at last change of memory**)

## Variant 2: Release Update with IndraWorks D

### Selection Criterion

The following requirements should have been fulfilled in order that carrying out the firmware release update with IndraWorks D makes sense:

- Controller is operated without MMC.
- or -
- Controller has been equipped with BASIC single-axis control section.

### Firmware Upgrade with IndraWorks D

Carrying out the firmware release update with IndraWorks D requires the following steps:

#### 1. Load firmware

- ⇒ Call IndraWorks D.
- ⇒ Load project for corresponding axis or create new project; to do this, address axis via a serial connection.
- ⇒ Switch project "online".
- ⇒ Select/highlight controller and call "Firmware management" in context menu.
  - A new window opens and firmware currently available in drive is displayed on its right side. On left side of window, firmware available in current firmware directory is displayed.
- ⇒ Highlight new firmware (\*.ibf file) on left side and start firmware download via "Download" button.
  - Firmware download runs automatically and all required firmware components are loaded to drive.
- ⇒ After firmware download has been completed, close "Firmware management" window.

#### 2. Put machine into ready-for-operation status

- ⇒ Put machine into ready-for-operation status again according to machine manufacturer's instructions.
- ⇒ Check functions of drive.



### 3. Check safety technology parameters (only when safety technology has been activated in drive)

In the case of a firmware release update, safety technology parameters are retained. With safety technology activated, the following steps are additionally required:

⇒ Check whether correct safety technology parameters for drive are still available.

To do this, check the following points:

- data in **P-0-3205, Safety technology device identifier**
- status of safety technology via **P-0-3207, Safety technology password level** (in the case of active and locked safety technology, level is 2)
- change counter of safety technology memory (**P-0-3201, Change counter of safety technology memory**)
- operating hours at last change of memory (**P-0-3202, Operating hours at last change of memory**)

## Firmware Version Upgrade

When firmware in a drive controller is replaced by firmware of a **new version**, this is called firmware version upgrade (e.g. FWA-INDRV\*-MPH-03V20-D5 replaced by FWA-INDRV\*-MPH-04V08-D5).

---

**Note:** **Before** carrying out the firmware version upgrade, you must save all parameters (e.g. with IndraWorks D). **After** firmware replacement the parameters must be restored because the command "C07\_1 Load defaults procedure command" is carried out automatically. After the desired parameter file was loaded, the drive controller is ready for operation again.

---

The described sequences of the firmware version upgrade depend on the configuration of the control section and the firmware used. The basically recommended sequence of the firmware version upgrade is illustrated in the scheme below:

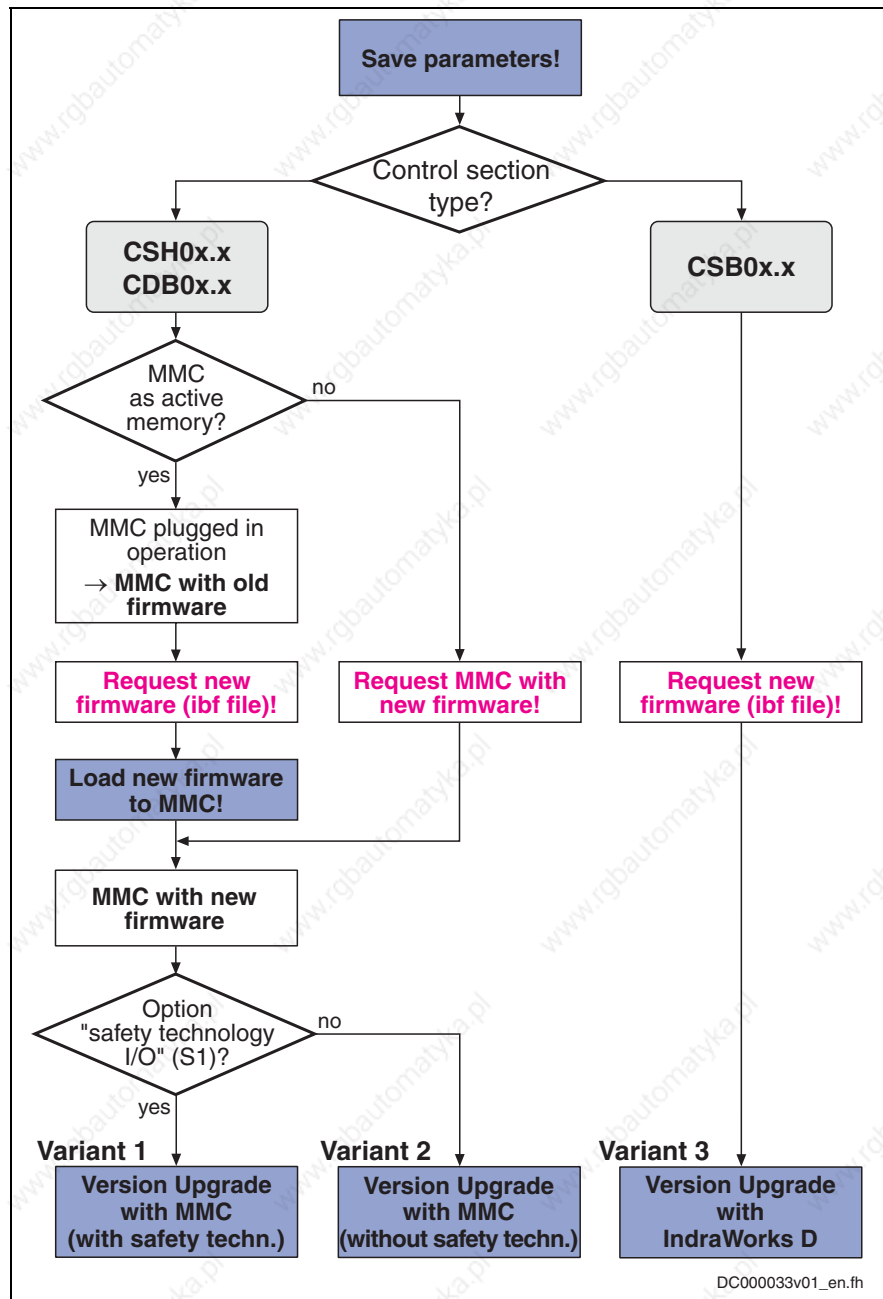

CSH0x.x:      ADVANCED single-axis control section  
 CDB0x.x:      BASIC double-axis control section  
 CSB0x.x:      BASIC single-axis control section  
 active memory: "programming module" operation of MMC (see P-0-4065)

Fig. 8-3: Schematic sequence of firmware version upgrade

**Note:** The action instructions marked with dark background in the illustration are described in the paragraphs below.

## Saving Parameters

Before firmware upgrade all application-specific parameters must be saved on a data carrier. Parameter backup can be carried out by means of:

- commissioning software "IndraWorks D"  
→ saving parameter values on external data carrier
- or -
- control master  
→ saving parameter values on master-side data carrier

---

**Note:** Saving the parameters on the MMC available in the drive is without effect, as this backup will be deleted during the firmware upgrade.

---

## Loading New Firmware to MMC

### Requirements

The following requirements must have been fulfilled for loading firmware to the MMC of the drive:

- new firmware available (ibf file)
- PC with MMC reader
- MMC with old firmware in drive

### Loading Firmware to MMC

The following steps are required for loading the firmware to the MMC:

1. Switch drive off and remove MMC.
2. Plug MMC into MMC reader and open folder "Firmware" on MMC.
3. Delete old firmware (e.g. FWA-INDRV\*-MPH-03V20-D5.ibf).
4. Copy new firmware (e.g. FWA-INDRV\*-MPH-04V08-D5.ibf) to folder "Firmware".

---

**Note:** Only one firmware file may be stored in the folder "Firmware" on the MMC. With several firmware files, the message "MMC not correct" appears on the display of the drive after booting.

---

5. Remove MMC from MMC reader after writing process has been completed.

## Variant 1: Version Upgrade with MMC (without Safety Technology)

### Selection Criterion

The following requirements should have been fulfilled in order that carrying out the firmware version upgrade with MMC makes sense (without safety technology):

- Controller has **not** been equipped with BASIC single-axis control section.
- Optional slot for safety technology has **not** been equipped with option "safety technology I/O" (S1).
- Current parameter setting of axis was saved.

**Firmware Upgrade with MMC  
(without Safety Technology)**

Carrying out the firmware version upgrade with MMC requires the following steps (without safety technology):

**1. Load firmware**

- ⇒ Switch drive off.
- ⇒ Plug MMC with new firmware into corresponding slot at controller.
- ⇒ Restart drive with MMC plugged.

After drive has been booted, the following message appears:

- "Firmware update?"

- ⇒ Acknowledge this message by pressing "Enter" key of control panel. By doing this, firmware is loaded from plugged MMC to controller.

If drive **before firmware replacement** was **operated without MMC plugged**, the following message appears:

- "Load new param.?"

→ Switch drive off, remove MMC and restart drive.

**2. Put drive into ready-for-operation status**

- ⇒ As number of parameters to be buffered has changed, "PL" appears on display (in case errors are present, remove them first). If you now press "Esc" key, all buffered parameters are set to their default values. During this time, message "C07 Load default parameters" appears on display.

**3. Load parameter values**

- ⇒ Load parameter file which was saved.
- ⇒ Switch drive off and restart it (only if drive was operated with MMC plugged).

**4. Put machine into ready-for-operation status**

- ⇒ Put machine into ready-for-operation status again according to machine manufacturer's instructions.
- ⇒ Check functions of drive.

**Variant 2: Version Upgrade with MMC (with Safety Technology)****Selection Criterion**

The following requirements should have been fulfilled in order that carrying out the firmware version upgrade with MMC makes sense (with safety technology):

- Controller has **not** been equipped with BASIC single-axis control section.
- Optional slot for safety technology has been equipped with option "safety technology I/O" (S1).
- Current parameter setting of axis was saved.

**Firmware Upgrade with MMC  
(with Safety Technology)**

Carrying out the firmware version upgrade with MMC requires the following steps (with safety technology):

**1. Load firmware**

- ⇒ Switch drive off.
- ⇒ Plug MMC with new firmware into corresponding slot at controller.
- ⇒ Restart drive with MMC plugged.

After drive has been booted, the following message appears:

- "Firmware update?"

⇒ Acknowledge this message by pressing "Enter" key of control panel. By doing this, firmware is loaded from plugged MMC to controller. If drive **before firmware replacement** was **operated without MMC plugged**, the following message appears:

- "Load new param.?"  
→ Switch drive off, remove MMC and restart drive.

## 2. Put drive into ready-for-operation status

⇒ As number of parameters to be buffered has changed, "PL" appears on display (in case errors are present, remove them first). If you now press "Esc" key, all buffered parameters are set to their default values. During this time, message "C07 Load default parameters" appears on display.

## 3. Load parameter values

⇒ Load parameter file which was saved.

If drive **before firmware replacement** was **operated with MMC plugged**:

→ Switch drive off, remove MMC and restart drive.

## 4. Complete commissioning of integrated safety technology

⇒ Switch drive to operating mode (communication phase 4).

If drive **before firmware replacement** was **operated without MMC plugged**, error message "F3152 Incorrect backup of safety technology data" appears as safety technology parameter set between firmware versions 02, 03 and 04 has changed.

→ Clear error message.

⇒ Activate command "synchronize and store safety technology IDN" (C3000).

⇒ Activate safety technology by inputting safety technology password (P-0-3206).

⇒ Carry out new acceptance test.



See sections "Activating the safety technology" and "Acceptance Test" in the separate documentation "Rexroth IndraDrive: Integrated Safety Technology" (DOK-INDRV\*-SI\*-\*\*VRS\*\*-\*FK\*\*-EN-P; part no. R911297838)

---

**Note:** After a firmware version upgrade for drive controllers with optional safety technology module ("S1"), you have to carry out a complete acceptance test.

---

⇒ Make safety technology parameter backup, compile acceptance test protocol and add it to safety-relevant documentation of machine.

## 5. Put machine into ready-for-operation status

⇒ Put machine into ready-for-operation status again according to machine manufacturer's instructions.

⇒ Check functions of drive.

### Variant 3: Version Upgrade with IndraWorks D

#### Selection Criterion

The following requirements should have been fulfilled in order that carrying out the firmware version upgrade with IndraWorks D makes sense:

- Controller has been equipped with BASIC single-axis control section.
- Current parameter setting of axis was saved.

#### Firmware Upgrade with IndraWorks D

Carrying out the firmware version upgrade with IndraWorks D requires the following steps:

##### 1. Load firmware

- ⇒ Call IndraWorks D.
- ⇒ Load project for corresponding axis or create new project. To do this, address axis via a serial connection.
- ⇒ Switch project "online".
- ⇒ Select/highlight controller and call "Firmware management" in context menu.
  - A new window opens and firmware currently available in drive is displayed on its right side. On left side of window, firmware available in current firmware directory is displayed.
- ⇒ Highlight new firmware (\*.ibf file) on left side and start firmware download via "Download" button.
  - Firmware download runs automatically and all required firmware components are loaded to drive.
- ⇒ After firmware download has been completed, close "Firmware management" window.

##### 2. Put drive into ready-for-operation status

- ⇒ Switch project "offline" and then "online" again.
  - After project has been switched online, a message signals that IndraWorks D could not establish communication to drive via serial interface, as drive-internal settings for serial communication were reset.
  - Reconfigure communication via button "Search for devices".
- ⇒ As firmware in drive no longer complies with version stored in project, a corresponding message is displayed. To adjust firmware version in project, first select option "Repair" and then options "Delete existing drive from project" and "Add new drive to project".
- ⇒ As number of parameters to be buffered has changed, "PL" appears on display (in case errors are present, clear them first). If you now press "Esc" key, all buffered parameters are set to their default values. During this time, message "C07 Load default parameters" appears on display.

##### 3. Load parameter values

- ⇒ Load parameter file which was saved.

##### 4. Put machine into ready-for-operation status

- ⇒ Put machine into ready-for-operation status again according to machine manufacturer's instructions.
- ⇒ Check functions of drive.

## Possible Problems during Firmware Replacement

**Problematic Situations** Firmware replacement is carried out incompletely if one of the following situations occurs during the sequence of firmware replacement:

- 24V supply of control section is switched off
- connection to drive is interrupted (e.g. defective interface cable)
- software crashes

The drive controller then possibly is no longer operable because the firmware contained in the components is no longer compatible.

If there isn't any valid firmware available in the control section in this case, the loader is started. The drive display signals "LOADER". The loader only allows updating the firmware of the control section. Optional cards, such as "safety technology I/O" (S1) or "cross communication" (CCD) cannot be programmed in this status. This must be done, after successful firmware replacement in the control section, in a second run according to the descriptions of the firmware replacement variants.

In this situation, replacement of the control section firmware is only supported by IndraWorks D.

---

**Note:** Upon successful firmware replacement in the control section, a restart has to be carried out. Then all available components have to be updated, too.

---

### Requirements for Loading the Firmware

The following requirements must have been fulfilled for loading firmware to the drive:

- serial connection to drive available
- drive display signals "LOADER"

### Firmware Replacement in Control Section in the Case of Error

The following steps are required for loading the firmware to the control section in the case of error:

1. Call IndraWorks D.
2. In menu call firmware management under "Extras → Extras → Drive → Firmware management".
3. Select device and COM interface.  
→ A new window opens and firmware available in current firmware directory is displayed on its left side.
4. Highlight new firmware (\*.ibf file) on left side and start firmware download via "Download" button.  
→ Firmware download runs automatically and all required firmware components are loaded to drive.
5. After firmware download has been completed, close "Firmware management" window.
6. Restart drive.

If drive has not been equipped with optional cards, such as "safety technology I/O" (S1) or "cross communication" (CCD), continue following instructions for release update or version upgrade! Otherwise, carry out release update or version upgrade again to program optional cards.

## 8.4 Service and Maintenance

### Deactivation

In the case of malfunctions, maintenance measures or to deactivate the motors, proceed as follows:

1. Observe the instructions of the machine documentation.
2. Use the machine-side control commands to bring the drive to a controlled standstill.
3. Switch off the power and control voltage of the drive controller.
4. **Only at motors with fan unit:** Switch off the motor protection switch for the motor fan.
5. Switch off the main switch of the machine.
6. Secure the machine against accidental movements and against unauthorized operation.
7. Wait for the discharge time of the electrical systems to expire and then disconnect all electrical connections.
8. Before dismantling, secure the motor and blower unit against falling or movements before disconnecting the mechanical connections.

### Dismantling



**DANGER**

#### Fatal injury due to errors in trigger motors and moving elements!

- ⇒ Do not work on unsecured and operating machines.
- ⇒ Secure the machine against accidental movements and against unauthorized operation.
- ⇒ Before dismantling, secure the motor and power supply against falling or movements before disconnecting the mechanical connections.



**WARNING**

#### Combustion via hot surface with temperatures over 100°C

- ⇒ Let the motor cool down, before maintenance. The stated thermal time constant in the technical data is a measure for the cooling time. A cooling time up to 140 minutes can be necessary!
- ⇒ Do not work on hot surfaces.
- ⇒ Use safety gloves.

1. Observe the instructions of the machine documentation.
2. Please heed the safety notes and carry out all steps as described in the anterior instructions in the chapter "Deactivation".
3. Before dismantling, secure the motor and power supply against falling or movements before disconnecting the mechanical connections.
4. Dismantle the motor from the machine. Store the motor properly!



## Disposal

**Products** Our products can be returned to us free of charge for disposal. It is a precondition, however, that the products are free of oil, grease or other dirt.

In addition, when returned the products mustn't contain any undue foreign matter or foreign component.

Please send the products free domicile to the following address:

Bosch Rexroth AG  
Electric Drives and Controls  
Bürgermeister-Dr.-Nebel-Straße 2  
D-97816 Lohr am Main

**Packaging Materials** The packaging materials consist of cardboard, wood and polystyrene. They can be easily recycled. For ecological reasons you should not return the empty packages to us.

## Environmental Protection

**No Release of Hazardous Substances** Our products do not contain any hazardous substances that they can release in the case of appropriate use. Normally there aren't any negative effects on the environment to be expected.

**Materials Contained in the Products** Electronic devices mainly contain:

- steel
- aluminum
- copper
- synthetic materials
- electronic components and modules

Motors mainly contain:

- steel
- aluminum
- copper
- brass
- magnetic materials
- electronic components and modules

**Recycling** Due to their high content of metal most of the product components can be recycled. In order to recycle the metal in the best possible way it is necessary to disassemble the products into individual modules.

The metals contained in the electric and electronic modules can also be recycled by means of specific separation processes.

The synthetic materials remaining after these processes can be thermally recycled.



## 9 Service & Support

### 9.1 Helpdesk

Unser Kundendienst-Helpdesk im Hauptwerk Lohr am Main steht Ihnen mit Rat und Tat zur Seite. Sie erreichen uns

Our service helpdesk at our headquarters in Lohr am Main, Germany can assist you in all kinds of inquiries. Contact us

- telefonisch - by phone: **+49 (0) 9352 40 50 60**  
über Service Call Entry Center Mo-Fr 07:00-18:00 Central European Time  
- via Service Call Entry Center Mo-Fr 7:00 am - 6:00 pm CET
- per Fax - by fax: **+49 (0) 9352 40 49 41**
- per e-Mail - by e-mail: [service.svc@boschrexroth.de](mailto:service.svc@boschrexroth.de)

### 9.2 Service-Hotline

Außerhalb der Helpdesk-Zeiten ist der Service Deutschland direkt ansprechbar unter

After helpdesk hours, contact the German service experts directly at

**+49 (0) 171 333 88 26**

oder - or

**+49 (0) 172 660 04 06**

Hotline-Rufnummern anderer Länder entnehmen Sie bitte den Adressen in den jeweiligen Regionen.

Hotline numbers of other countries to be seen in the addresses of each region.

### 9.3 Internet

Unter **[www.boschrexroth.com](http://www.boschrexroth.com)** finden Sie ergänzende Hinweise zu Service, Reparatur und Training sowie die **aktuellen** Adressen \*) unserer auf den folgenden Seiten aufgeführten Vertriebs- und Servicebüros.

At **[www.boschrexroth.com](http://www.boschrexroth.com)** you can find additional notes about service, repairs and training. The current addresses \*) for our sales and service facilities locations around the world are on the following pages.



Verkaufsniederlassungen



Niederlassungen mit Kundendienst

Außerhalb Deutschlands nehmen Sie bitte zuerst Kontakt mit unserem für Sie nächstgelegenen Ansprechpartner auf.



sales agencies



sales agencies providing service

Please contact our sales / service office in your area first.

\*) Die Angaben in der vorliegenden Dokumentation können seit Drucklegung überholt sein.

\*) Data in the present documentation may have become obsolete since printing.

### 9.4 Vor der Kontaktaufnahme... - Before contacting us...

Wir können Ihnen schnell und effizient helfen wenn Sie folgende Informationen bereithalten:

For quick and efficient help, please have the following information ready:

1. detaillierte Beschreibung der Störung und der Umstände.
2. Angaben auf dem Typenschild der betreffenden Produkte, insbesondere Typenschlüssel und Seriennummern.
3. Tel./Faxnummern und e-Mail-Adresse, unter denen Sie für Rückfragen zu erreichen sind.

1. Detailed description of the failure and circumstances.
2. Information on the type plate of the affected products, especially type codes and serial numbers.
3. Your phone/fax numbers and e-mail address, so we can contact you in case of questions.

## 9.5 Kundenbetreuungsstellen - Sales & Service Facilities

### Deutschland – Germany

**vom Ausland:** (0) nach Landeskennziffer weglassen!  
from abroad: don't dial (0) after country code!

<b>Vertriebsgebiet Mitte</b> Germany Centre  Bosch Rexroth Electrice Drives and Controls GmbH Bgm.-Dr.-Nebel-Str. 2 / Postf. 1357 97816 Lohr am Main / 97803 Lohr <b>Kompetenz-Zentrum Europa</b>  Tel.: +49 (0)9352 40-0 Fax: +49 (0)9352 40-4885	<b>SERVICE AUTOMATION</b>  <b>CALL ENTRY CENTER</b> <b>Helpdesk</b> <b>MO – FR</b> von 07:00 - 18:00 Uhr from 7 am – 6 pm  <b>Tel. +49 (0) 9352 40 50 60</b> <b>Fax +49 (0) 9352 40 49 41</b> service.svc@boschrexroth.de	<b>SERVICE AUTOMATION</b>  <b>HOTLINE 24 / 7 / 365</b>  <b>außerhalb der Helpdesk-Zeit</b> <b>out of helpdesk hours</b>  <b>Tel.: +49 (0)172 660 04 06</b> oder / or <b>Tel.: +49 (0)171 333 88 26</b>	<b>SERVICE AUTOMATION</b>  <b>ERSATZTEILE / SPARES</b> verlängerte Ansprechzeit - extended office time - ♦ nur an Werktagen - only on working days - ♦ von 07:00 - 18:00 Uhr - from 7 am - 6 pm - <b>Tel. +49 (0) 9352 40 42 22</b>
<b>Vertriebsgebiet Süd</b> Germany South  Bosch Rexroth AG Landshuter Allee 8-10 80637 München  Tel.: +49 (0)89 127 14-0 Fax: +49 (0)89 127 14-490	<b>Vertriebsgebiet West</b> Germany West  Bosch Rexroth AG Regionalzentrum West Borsigstrasse 15 40880 Ratingen  Tel.: +49 (0)2102 409-0 Fax: +49 (0)2102 409-406 +49 (0)2102 409-430	<b>Gebiet Südwest</b> Germany South-West  Bosch Rexroth AG Service-Regionalzentrum Süd-West Siemensstr. 1 70736 Fellbach  Tel.: +49 (0)711 51046-0 Fax: +49 (0)711 51046-248	
<b>Vertriebsgebiet Nord</b> Germany North  Bosch Rexroth AG Walsroder Str. 93 30853 Langenhagen  Tel.: +49 (0) 511 72 66 57-0 Service: +49 (0) 511 72 66 57-256 Fax: +49 (0) 511 72 66 57-93 Service: +49 (0) 511 72 66 57-783	<b>Vertriebsgebiet Mitte</b> Germany Centre  Bosch Rexroth AG Regionalzentrum Mitte Waldecker Straße 13 64546 Mörfelden-Walldorf  Tel.: +49 (0) 61 05 702-3 Fax: +49 (0) 61 05 702-444	<b>Vertriebsgebiet Ost</b> Germany East  Bosch Rexroth AG Beckerstraße 31 09120 Chemnitz  Tel.: +49 (0)371 35 55-0 Fax: +49 (0)371 35 55-333	<b>Vertriebsgebiet Ost</b> Germany East  Bosch Rexroth AG Regionalzentrum Ost Walter-Köhn-Str. 4d 04356 Leipzig  Tel.: +49 (0)341 25 61-0 Fax: +49 (0)341 25 61-111

## Europa (West) - Europe (West)

**vom Ausland:** (0) nach Landeskennziffer weglassen, **Italien:** 0 nach Landeskennziffer mitwählen  
**from abroad:** don't dial (0) after country code, **Italy:** dial 0 after country code

<p>Austria - Österreich</p> <p>Bosch Rexroth GmbH Electric Drives &amp; Controls Stachegasse 13 1120 Wien</p> <p>Tel.: +43 (0) 1 985 25 40 Fax: +43 (0) 1 985 25 40-1459</p>	<p>Austria – Österreich</p> <p>Bosch Rexroth GmbH Electric Drives &amp; Controls Industriepark 18 4061 Pasching</p> <p>Tel.: +43 (0)7221 605-0 Fax: +43 (0)7221 605-1220</p>	<p>Belgium - Belgien</p> <p>Bosch Rexroth NV/SA Henri Genessestraat 1 1070 Bruxelles</p> <p>Tel: +32 (0) 2 451 26 08 Fax: +32 (0) 2 451 27 90 <a href="mailto:info@boschrexroth.be">info@boschrexroth.be</a> <a href="mailto:service@boschrexroth.be">service@boschrexroth.be</a></p>	<p>Denmark - Dänemark</p> <p>BEC A/S Zinkvej 6 8900 Randers</p> <p>Tel.: +45 87 11 90 60 Fax: +45 87 11 90 61</p>
<p>Denmark - Dänemark</p> <p>Bosch Rexroth A/S Engelsholmvej 26 8900 Randers</p> <p>Tel.: +45 36 77 44 66 Fax: +45 70 10 03 20 <a href="mailto:tj@boschrexroth.dk">tj@boschrexroth.dk</a></p>	<p>Great Britain – Großbritannien</p> <p>Bosch Rexroth Ltd. Electric Drives &amp; Controls Broadway Lane, South Cerney Cirencester, Glos GL7 5UH</p> <p>Tel.: +44 (0)1285 863-000 Fax: +44 (0)1285 863-030 <a href="mailto:sales@boschrexroth.co.uk">sales@boschrexroth.co.uk</a> <a href="mailto:service@boschrexroth.co.uk">service@boschrexroth.co.uk</a></p>	<p>Finland - Finnland</p> <p>Bosch Rexroth Oy Electric Drives &amp; Controls Ansatie 6 01740 Vantaa</p> <p>Tel.: +358 10 3441 000 Fax: +358 10 3441 506</p>	<p>France - Frankreich</p> <p>Bosch Rexroth SAS Electric Drives &amp; Controls Avenue de la Trentaine (BP. 74) 77503 Chelles Cedex</p> <p>Tel.: +33 (0)164 72-63 22 Fax: +33 (0)164 72-63 20 <b>Hotline: +33 (0)608 33 43 28</b></p>
<p>France - Frankreich</p> <p>Bosch Rexroth SAS Electric Drives &amp; Controls ZI de Thibaud, 20 bd. Thibaud (BP. 1751) 31084 Toulouse</p> <p>Tel.: +33 (0)5 61 43 61 87 Fax: +33 (0)5 61 43 94 12</p>	<p>France – Frankreich</p> <p>Bosch Rexroth SAS Electric Drives &amp; Controls 91, Bd. Irène Joliot-Curie 69634 Vénissieux – Cedex</p> <p>Tel.: +33 (0)4 78 78 53 65 Fax: +33 (0)4 78 78 53 62</p>	<p>France – Frankreich</p> <p><b>Tightening &amp; Press-fit:</b> Globe Techniques Nouvelles 143, Av. du Général de Gaulle 92252 La Garenne Colombes</p> <p>Tel.: +33 (0)1 41 19 33 33</p>	<p>Italy - Italien</p> <p>Bosch Rexroth S.p.A. Strada Statale Padana Superiore 11, no. 41 20063 Cernusco S/N.MI</p> <p>Tel.: +39 02 92 365 1 Service: +39 02 92 365 300 Fax: +39 02 92 365 500 Service: +39 02 92 365 516</p>
<p>Italy - Italien</p> <p>Bosch Rexroth S.p.A. Via Paolo Veronesi, 250 10148 Torino</p> <p>Tel.: +39 011 224 88 11 Fax: +39 011 224 88 30</p>	<p>Italy - Italien</p> <p>Bosch Rexroth S.p.A. Via Mascia, 1 80053 Castellammare di Stabia NA</p> <p>Tel.: +39 081 8 71 57 00 Fax: +39 081 8 71 68 85</p>	<p>Italy - Italien</p> <p>Bosch Rexroth S.p.A. Via del Progresso, 16 (Zona Ind.) 35020 Padova</p> <p>Tel.: +39 049 8 70 13 70 Fax: +39 049 8 70 13 77</p>	<p>Italy - Italien</p> <p>Bosch Rexroth S.p.A. Via Isonzo, 61 40033 Casalecchio di Reno (Bo)</p> <p>Tel.: +39 051 29 86 430 Fax: +39 051 29 86 490</p>
<p>Italy - Italien</p> <p><b>Tightening &amp; Press-fit:</b> TEMA S.p.A. Automazione Via Juker, 28 20025 Legnano</p> <p>Tel.: +39 0 331 4671</p>	<p>Netherlands – Niederlande/Holland</p> <p>Bosch Rexroth B.V. Kruisbroeksestraat 1 (P.O. Box 32) 5281 RV Boxtel</p> <p>Tel.: +31 (0) 411 65 16 40 Fax: +31 (0) 411 65 14 83 <a href="http://www.boschrexroth.nl">www.boschrexroth.nl</a></p>	<p>Netherlands - Niederlande/Holland</p> <p>Bosch Rexroth Services B.V. Technical Services Kruisbroeksestraat 1 (P.O. Box 32) 5281 RV Boxtel</p> <p>Tel.: +31 (0) 411 65 19 51 Fax: +31 (0) 411 67 78 14 <b>Hotline: +31 (0) 411 65 19 51</b> <a href="mailto:services@boschrexroth.nl">services@boschrexroth.nl</a></p>	<p>Norway - Norwegen</p> <p>Bosch Rexroth AS Electric Drives &amp; Controls Berghagan 1 or: Box 3007 1405 Ski-Langhus 1402 Ski</p> <p>Tel.: +47 64 86 41 00 Fax: +47 64 86 90 62 <b>Hotline: +47 64 86 94 82</b> <a href="mailto:arnt.kristian.barsten@boschrexroth.no">arnt.kristian.barsten@boschrexroth.no</a></p>
<p>Spain – Spanien</p> <p>Goimendi Automation S.L. Parque Empresarial Zuatzu C/ Francisco Grandmontagne no.2 20018 San Sebastian</p> <p>Tel.: +34 9 43 31 84 21 - service: +34 9 43 31 84 56 Fax: +34 9 43 31 84 27 - service: +34 9 43 31 84 60 <a href="mailto:sat.indramat@goimendi.es">sat.indramat@goimendi.es</a></p>	<p>Spain - Spanien</p> <p>Bosch Rexroth S.A. Electric Drives &amp; Controls Centro Industrial Santaiga Obradors 14-16 08130 Santa Perpetua de Mogoda Barcelona</p> <p>Tel.: +34 9 37 47 94-00 Fax: +34 9 37 47 94-01</p>	<p>Spain - Spanien</p> <p>Bosch Rexroth S.A. Electric Drives &amp; Controls c/ Almazara, 9 28760 Tres Cantos (Madrid)</p> <p>Tel.: +34 91 806 24 79 Fax: +34 91 806 24 72 <a href="mailto:fernando.bariego@boschrexroth.es">fernando.bariego@boschrexroth.es</a></p>	<p>Sweden - Schweden</p> <p>Bosch Rexroth AB Electric Drives &amp; Controls - Varuvägen 7 (Service: Konsumentvägen 4, Älfsjö) 125 81 Stockholm</p> <p>Tel.: +46 (0) 8 727 92 00 Fax: +46 (0) 8 647 32 77</p>
<p>Sweden - Schweden</p> <p>Bosch Rexroth AB Electric Drives &amp; Controls Ekvåndan 7 254 67 Helsingborg</p> <p>Tel.: +46 (0) 4 238 88 -50 Fax: +46 (0) 4 238 88 -74</p>	<p>Switzerland East - Schweiz Ost</p> <p>Bosch Rexroth Schweiz AG Electric Drives &amp; Controls Hemrietstrasse 2 8863 Buttikon</p> <p>Tel. +41 (0) 55 46 46 111 Fax +41 (0) 55 46 46 222</p>	<p>Switzerland West - Schweiz West</p> <p>Bosch Rexroth Suisse SA Av. Général Guisan 26 1800 Vevey 1</p> <p>Tel.: +41 (0)21 632 84 20 Fax: +41 (0)21 632 84 21</p>	

## Europa (Ost) - Europe (East)

**vom Ausland:** (0) nach Landeskenziffer weglassen  
from abroad: don't dial (0) after country code

Czech Republic - Tschechien Bosch -Rexroth, spol.s.r.o. Hviezdoslavova 5 627 00 Brno Tel.: +420 (0)5 48 126 358 Fax: +420 (0)5 48 126 112	Czech Republic - Tschechien <b>Tightening &amp; Press-fit:</b> Bosch -Rexroth, spol.s.r.o. Stetkova 18 140 68 Praha 4 Tel.: +420 (0)241 406 675	Hungary - Ungarn Bosch Rexroth Kft. Angol utca 34 1149 Budapest Tel.: +36 (1) 422 3200 Fax: +36 (1) 422 3201	Poland – Polen Bosch Rexroth Sp.zo.o. ul. Staszica 1 05-800 Pruszków Tel.: +48 (0) 22 738 18 00 – service: +48 (0) 22 738 18 46 Fax: +48 (0) 22 758 87 35 – service: +48 (0) 22 738 18 42
Poland – Polen Bosch Rexroth Sp.zo.o. Biuro Poznan ul. Dabrowskiego 81/85 60-529 Poznan Tel.: +48 061 847 64 62 /-63 Fax: +48 061 847 64 02	Romania - Rumänien East Electric S.R.L. Bdul Basarabia no.250, sector 3 73429 Bucuresti Tel./Fax.: +40 (0)21 255 35 07 +40 (0)21 255 77 13 Fax: +40 (0)21 725 61 21 <a href="mailto:eastel@rdsnet.ro">eastel@rdsnet.ro</a>	Romania - Rumänien Bosch Rexroth Sp.zo.o. Str. Drobety nr. 4-10, app. 14 70258 Bucuresti, Sector 2 Tel.: +40 (0)1 210 48 25 +40 (0)1 210 29 50 Fax: +40 (0)1 210 29 52	Russia - Russland Bosch Rexroth OOO Tschschjolowskoje Chaussee 100 105523 Moskau Tel.: +7-495-783 30 60 + 64 +7-495 783 30 68 + 69 <a href="mailto:brschrexroth.ru">brschrexroth.ru</a>
Turkey - Türkei Bosch Rexroth Otomasyon San & Tic. A..S. Fevzi Cakmak Cad No. 3 34295 Sefaköy Istanbul Tel.: +90 212 411-13 00 Fax: +90 212 411-13 17 <a href="http://www.boschrexroth.com.tr">www.boschrexroth.com.tr</a>	Turkey - Türkei Servo Kontrol Ltd. Sti. Perpa Ticaret Merkezi B Blok Kat: 11 No: 1609 80270 Okmeydani-Istanbul Tel.: +90 212 320 30 80 +90 212 320 30 81 <a href="mailto:remzi.sali@servokontrol.com">remzi.sali@servokontrol.com</a> <a href="http://www.servokontrol.com">www.servokontrol.com</a>	Slowakia - Slowakei <b>Tightening &amp; Press-fit:</b> MTS, spol. s.r.o. 02755 Kriva 53 Tel.: +421 43 5819 161	Slowenia - Slowenien DOMEL Otoki 21 64 228 Zelezniki Tel.: +386 5 5117 152 Fax: +386 5 5117 225 <a href="mailto:brane.ozebek@domel.si">brane.ozebek@domel.si</a>

## Australien, Süd-Afrika - Australia, South Africa

Australia - Australien AIMS - Australian Industrial Machinery Services Pty. Ltd. 28 Westside Drive Laverton North Vic 3026 Melbourne Tel.: +61 3 93 14 3321 Fax: +61 3 93 14 3329 <b>Hotlines: +61 3 93 14 3321</b> <b>+61 4 19 369 195</b> <a href="mailto:enquires@aimsservices.com.au">enquires@aimsservices.com.au</a>	Australia - Australien Bosch Rexroth Pty. Ltd. No. 7, Endeavour Way Braeside Victoria, 31 95 Melbourne Tel.: +61 3 95 80 39 33 Fax: +61 3 95 80 17 33 <a href="mailto:mel@rexroth.com.au">mel@rexroth.com.au</a>	South Africa - Südafrika TECTRA Automation (Pty) Ltd. 100 Newton Road, Meadowdale Edenvale 1609 Tel.: +27 11 971 94 00 Fax: +27 11 971 94 40 <b>Hotline: +27 82 903 29 23</b> <a href="mailto:georgv@tectra.co.za">georgv@tectra.co.za</a>	South Africa - Südafrika <b>Tightening &amp; Press-fit:</b> Jendamark Automation 76A York Road, North End 6000 Port Elizabeth Tel.: +27 41 391 4735
--	---	---	--

## Asien - Asia (incl. Pacific Rim)

China	China	China	China
Shanghai Bosch Rexroth Hydraulics & Automation Ltd. No.122, Fu Te Dong Yi Road Waigaoqiao, Free Trade Zone Shanghai 200131 - P.R.China	Shanghai Bosch Rexroth Hydraulics & Automation Ltd. 4/f, Marine Tower No.1, Pudong Avenue Shanghai 200120 - P.R.China	Bosch Rexroth (China) Ltd. Satellite Service Office Changchun Rm. 1910, Guangming Building No.336 Xi'an Rd., Chao Yang Distr. Changchun 130061 - P.R.China	Bosch Rexroth (China) Ltd. Satellite Service Office Wuhan No. 22, Pinglanju, Milanyuan, Golden Harbor No. 236 Longyang Avenue Economic & Technology Development Zone Wuhan 430056 - P.R.China
Tel.: +86 21 58 66 30 30 Fax: +86 21 58 66 55 23 <a href="mailto:brcservice@boschrexroth.com.cn">brcservice@boschrexroth.com.cn</a>	Tel: +86 21 68 86 15 88 Fax: +86 21 68 86 05 99 +86 21 58 40 65 77 <a href="mailto:y.wu@boschrexroth.com.cn">y.wu@boschrexroth.com.cn</a>	Tel.+Fax: +86 431 898 1129 Mobile: +86 139 431 92 659 <a href="mailto:shuhong.wang@boschrexroth.com.cn">shuhong.wang@boschrexroth.com.cn</a>	Tel.+Fax: +86 27 84 23 23 92 Mobile: +86 139 71 58 89 67 <a href="mailto:ym.zhu@boschrexroth.com.cn">ym.zhu@boschrexroth.com.cn</a>
China	China	China	China
Bosch Rexroth (China) Ltd. Beijing Representative Office Xi San Qi Dong, De Sheng Mei Wai Hai Dian District Beijing 100096, P.R.China	Bosch Rexroth (China) Ltd. Guangzhou Repres. Office Room 3710-3716, Metro Plaza, Tian He District, 183 Tian He Bei Rd Guangzhou 510075, P.R.China	Bosch Rexroth (China) Ltd. Dalian Representative Office Room 2005, Pearl River Int. Building No.99 Xin Kai Rd., Xi Gang District Dalian, 116011, P.R.China	<b>Tightening &amp; Press-fit:</b> C. Melchers GmbH & Co Shanghai Representation 13 Floor Est Ocean Centre No.588 Yanan Rd. East 65 Yanan Rd. West Shanghai 200001
Tel.: +86 10 82 91 22 29 Fax: +86 10 82 91 81 09 <a href="mailto:van.zhang@boschrexroth.com.cn">van.zhang@boschrexroth.com.cn</a>	Tel.: +86 20 87 55 00 30 +86 20 87 55 00 11 Fax: +86 20 87 55 23 87 <a href="mailto:ndrew.wang@boschrexroth.com.cn">ndrew.wang@boschrexroth.com.cn</a>	Tel.: +86 411 83 68 26 02 Fax: +86 411 83 68 27 02 <a href="mailto:jason.tan@boschrexroth.com.cn">jason.tan@boschrexroth.com.cn</a>	Tel.: +86 21 63 52 88 48 Fax: +86 21 63 51 31 38 <a href="mailto:shermanxia@sh.melchers.com.cn">shermanxia@sh.melchers.com.cn</a>
Hongkong	India - Indien	India - Indien	India - Indien
Bosch Rexroth (China) Ltd. 6 <sup>th</sup> Floor, Yeung Yiu Chung No.6 Ind Bldg. 19 Cheung Shun Street Cheung Sha Wan, Kowloon, Hongkong	Bosch Rexroth (India) Ltd. Electric Drives & Controls Plot. No.96, Phase III Peenya Industrial Area Bangalore – 560058	Bosch Rexroth (India) Ltd. Electric Drives & Controls Advance House, II Floor Ark Industrial Compound Narol Naka, Makwana Road Andheri (East), Mumbai - 400 059	<b>Tightening &amp; Press-fit:</b>  MICO Hosur Road Adugodi 560 030 Bangalore Karnataka
Tel.: +852 27 86 46 32 Fax: +852 27 42 60 57 <a href="mailto:Paul.li@boschrexroth.com.cn">Paul.li@boschrexroth.com.cn</a>	Tel.: +91 80 41 17 0211 Fax: +91 80 83 97 374 <a href="mailto:pradeep.rs@boschrexroth.co.in">pradeep.rs@boschrexroth.co.in</a>	Tel.: +91 22 28 56 32 90 +91 22 28 56 33 18 Fax: +91 22 28 56 32 93 <a href="mailto:singh.op@boschrexroth.co.in">singh.op@boschrexroth.co.in</a>	Tel.: +91 80 22 99 28 86
India - Indien	Indonesia - Indonesien	Japan	Japan
Bosch Rexroth (India) Ltd. S-10, Green Park Extension New Delhi – 110016	PT. Bosch Rexroth Building # 202, Cilandak Commercial Estate Jl. Cilandak KKO, Jakarta 12560	Bosch Rexroth Corporation Service Center Japan 2125-1 atsukawado-cho Kasugai-shi Aichi-ken 486-0932, Japan	Bosch Rexroth Corporation Electric Drives & Controls BOSCH Bldg. 4F, 3-6-7 Shibuya Shibuya-ku, Tokyo 150-0002, Japan
Tel.: +91 11 26 56 65 25 +91 11 26 56 65 27 Fax: +91 11 26 56 68 87 <a href="mailto:koul.rp@boschrexroth.co.in">koul.rp@boschrexroth.co.in</a>	Tel.: +62 21 7891169 (5 lines) Fax: +62 21 7891170 - 71 <a href="mailto:rudy.karimun@boschrexroth.co.id">rudy.karimun@boschrexroth.co.id</a>	Tel.: +81 568 35 7701 Fax: +81 568 35 7705	Tel : +81 354 85 7240 Fax: +81 354 85 7241
Korea	Korea	Korea	Korea
Bosch Rexroth-Korea Ltd. Electric Drives & Controls 1515-14 Dadae-Dong, Saha-gu Pusan Metropolitan City, 604-050	Bosch Rexroth-Korea Ltd. Electric Drives and Controls Bongwoo Bldg. 7FL, 31-7, 1Ga Jangchoong-dong, Jung-gu Seoul, 100-391	Bosch Rexroth-Korea Ltd. Electric Drives & Controls 1515-14 Dadae-Dong, Saha-gu Ulsan, 680-010	<b>Tightening &amp; Press-fit:</b> KVT Co., Ltd. 901, Daeryung Techno Town 8 481-11 Gasan-Dong Geumcheon-Gu Seoul, 153-775
Tel.: +82 51 26 00 741 Fax: +82 51 26 00 747 <a href="mailto:eunkyong.kim@boschrexroth.co.kr">eunkyong.kim@boschrexroth.co.kr</a>	Tel.: +82 234 061 813 Fax: +82 222 641 295	Tel.: +82 52 256-0734 Fax: +82 52 256-0738 <a href="mailto:eonhyun.jeong@boschrexroth.co.kr">eonhyun.jeong@boschrexroth.co.kr</a>	Tel.: +82 2 2163 0231 9
Malaysia	Singapore - Singapur	Taiwan	Taiwan
Bosch Rexroth Sdn.Bhd. 11, Jalan U8/82, Seksyen U8 40150 Shah Alam Selangor, Malaysia	Bosch Rexroth Pte Ltd 15D Tuas Road Singapore 638520	Bosch Rexroth Co., Ltd. Taichung Industrial Area No.19, 38 Road Taichung, Taiwan 407, R.O.C.	Bosch Rexroth Co., Ltd. Tainan Branch No. 17, Alley 24, Lane 737 Chung Cheng N.Rd. Yungkang Tainan Hsien, Taiwan, R.O.C.
Tel.: +60 3 78 44 80 00 Fax: +60 3 78 45 48 00 <a href="mailto:hhlum@boschrexroth.com.my">hhlum@boschrexroth.com.my</a>	Tel.: +65 68 61 87 33 Fax: +65 68 61 18 25 <a href="mailto:raymond.toh@boschrexroth.com.sg">raymond.toh@boschrexroth.com.sg</a>	Tel : +886 - 4 -235 08 383 Fax: +886 - 4 -235 08 586 <a href="mailto:jim.lin@boschrexroth.com.tw">jim.lin@boschrexroth.com.tw</a> <a href="mailto:david.lai@boschrexroth.com.tw">david.lai@boschrexroth.com.tw</a>	Tel : +886 - 6 -253 6565 Fax: +886 - 6 -253 4754 <a href="mailto:charlie.chen@boschrexroth.com.tw">charlie.chen@boschrexroth.com.tw</a>
Thailand			
NC Advance Technology Co. Ltd. 59/76 Moo 9, Ramintra road 34 Tharang, Bangkok, Bangkok 10230			
Tel.: +66 2 943 70 62 +66 2 943 71 21 Fax: +66 2 509 23 62 Hotline +66 1 984 61 52 <a href="mailto:sonkawin@hotmail.com">sonkawin@hotmail.com</a>			

## Nordamerika – North America

<b>USA</b> Headquarters - Hauptniederlassung Bosch Rexroth Corporation Electric Drives & Controls 5150 Prairie Stone Parkway Hoffman Estates, IL 60192-3707 Tel.: +1 847 645-3600 Fax: +1 847 645-6201 <a href="mailto:servicebrc@boschrexroth-us.com">servicebrc@boschrexroth-us.com</a> <a href="mailto:repairbrc@boschrexroth-us.com">repairbrc@boschrexroth-us.com</a>	<b>USA Central Region - Mitte</b> Bosch Rexroth Corporation Electric Drives & Controls 1701 Harmon Road Auburn Hills, MI 48326 Tel.: +1 248 393-3330 Fax: +1 248 393-2906	<b>USA Southeast Region - Südost</b> Bosch Rexroth Corporation Electric Drives & Controls 2810 Premiere Parkway, Suite 500 Duluth, GA 30097 Tel.: +1 678 957-4050 Fax: +1 678 417-6637	<b>USA SERVICE-HOTLINE</b> - 7 days week/ 24 hrs day - <b>+1-800-REXROTH</b> <b>+1 800 739 7684</b>
<b>USA Northeast Region – Nordost</b> Bosch Rexroth Corporation Electric Drives & Controls 99 Rainbow Road East Granby, CT 06026 Tel.: +1 860 844-8377 Fax: +1 860 844-8595	<b>USA West Region – West</b> Bosch Rexroth Corporation Electric Drives & Controls 7901 Stoneridge Drive, Suite 220 Pleasanton, CA 94588 Tel.: +1 925 227-1084 Fax: +1 925 227-1081	<b>Canada East - Kanada Ost</b> Bosch Rexroth Canada Corporation 5345 Outer Drive unit 5 Windsor, Ontario Canada N9A 6J3 Tel.: +1 519 737 7393 Fax.: +1 519 737 9999	<b>Canada East - Kanada Ost</b> Bosch Rexroth Canada Corporation Automation Division 3426 Mainway Drive Burlington, Ontario Canada L7M 1A8 Tel.: +1 905 335 5511 Fax: +1 905 335 4184 (Main) +1 905 335 9803 (Serv.) <a href="mailto:automation.service@boschrexroth.ca">automation.service@boschrexroth.ca</a> <a href="mailto:automation.repair@boschrexroth.ca">automation.repair@boschrexroth.ca</a>
<b>Canada West - Kanada West</b> Bosch Rexroth Canada Corporation 5345 Goring St. Burnaby, British Columbia Canada V7J 1R1 Tel.: +1 604 205 5777 Fax: +1 604 205 6944 <a href="mailto:automation.service@boschrexroth.ca">automation.service@boschrexroth.ca</a> <a href="mailto:automation.repair@boschrexroth.ca">automation.repair@boschrexroth.ca</a>	<b>CANADA SERVICE HOTLINE</b> - 7 days week/ 24 hrs day - <b>+1 905 335 5511</b>	<b>Mexico</b> Bosch Rexroth Mexico S.A. de C.V. Calle Neptuno 72 Unidad Ind. Vallejo 07700 Mexico, D.F. Tel.: +52 55 57 54 17 11 Fax: +52 55 57 54 50 73 <a href="mailto:mario.francioli@boschrexroth.com.mx">mario.francioli@boschrexroth.com.mx</a>	<b>Mexico</b> Bosch Rexroth S.A. de C.V. Calle Argentina No 3913 Fracc. las Torres 64930 Monterrey, N.L. Tel.: +52 81 83 49 80 91 +52 81 83 49 80 92 +52 81 83 49 80 93 Fax: +52 81 83 65 52 80

## Südamerika – South America

<b>Argentina - Argentinien</b> Bosch Rexroth S.A.I.C. "The Drive & Control Company" Rosario 2302 B1606DLD Carapachay Provincia de Buenos Aires Tel.: +54 11 4756 01 40 +54 11 4756 02 40 +54 11 4756 03 40 +54 11 4756 04 40 Fax: +54 11 4756 01 36 +54 11 4721 91 53 <a href="mailto:victor.jabif@boschrexroth.com.ar">victor.jabif@boschrexroth.com.ar</a>	<b>Argentina - Argentinien</b> NAKASE SRL Servicio Tecnico CNC Calle 49, No. 5764/66 B1653AOX Villa Balester Provincia de Buenos Aires Tel.: +54 11 4768 42 42 Fax: +54 11 4768 42 42 111 <b>Hotline: +54 11 155 307 6781</b> <a href="mailto:nakase@nakase.com">nakase@nakase.com</a>	<b>Brazil - Brasilien</b> Bosch Rexroth Ltda. Av. Tégula, 888 Ponte Alta, Atibaia SP CEP 12942-440 Tel.: +55 11 4414 -56 92 +55 11 4414 -56 84 Fax sales: +55 11 4414 -57 07 Fax serv.: +55 11 4414 -56 86 <a href="mailto:alexandre.wittwer@rexroth.com.br">alexandre.wittwer@rexroth.com.br</a>	<b>Brazil - Brasilien</b> Bosch Rexroth Ltda. R. Dr.Humberto Pinheiro Vieira, 100 Distrito Industrial [Caixa Postal 1273] 89220-390 Joinville - SC Tel./Fax: +55 47 473 58 33 Mobil: +55 47 9974 6645 <a href="mailto:sergio.prochnow@boschrexroth.com.br">sergio.prochnow@boschrexroth.com.br</a>
<b>Columbia - Kolumbien</b> Refflutec de Colombia Ltda. Calle 37 No. 22-31 Santafé de Bogotá, D.C. Colombia Tel.: +57 1 208 65 55 Fax: +57 1 269 97 37 <a href="mailto:refflutec@etb.net.co">refflutec@etb.net.co</a>			



# 10 Index

## 2

24V supply 5-2  
installation 6-35

## A

Absolute voltage value, actual value 7-56  
Acceleration data scaling type 7-45  
Acceleration factors for velocity masking window 7-93  
Acceleration feedforward smoothing time constant 7-60  
accessories  
HAS01 6-68  
HAS02 6-72  
HAS05 6-84  
Activation E-Stop function 7-52  
Activation of NC reaction on error 7-59  
Active functional packages 7-96  
Actual output current value (absolute value) 7-75  
Actual value peak torque limit 7-76  
Actual value torque limit negative (stationary) 7-76  
Actual value torque limit positive (stationary) 7-76  
additional components 5-15  
Additive position command value, controller 7-55  
Additive velocity command value 7-37  
Additive velocity command value, process loop 7-85  
administration commands 1-3  
ambient conditions 4-7  
Amplifier nominal current 7-42  
Amplifier peak current 7-42  
Amplifier temperature 7-50  
Analog input 1 7-64  
Analog input 1, time constant input filter 7-66  
Analog input 2 7-64  
Analog input 2, time constant input filter 7-68  
Analog input 3 7-67  
Analog input 3, time constant input filter 7-68  
Analog input 4 7-68  
Analog input 4, time constant input filter 7-68  
Analog input 5 7-63  
Analog input 5, time constant input filter 7-69  
Analog input 6 7-64  
Analog input 6, time constant input filter 7-69  
Analog input, assignment A, dead zone 7-65  
Analog input, assignment A, scaling per 10V full scale 7-65  
Analog input, assignment A, signal value at 0V 7-65  
Analog input, assignment A, target parameter 7-64  
Analog input, assignment B, dead zone 7-70  
Analog input, assignment B, scaling per 10V full scale 7-70  
Analog input, assignment B, signal value at 0V 7-70  
Analog input, assignment B, target parameter 7-69  
Analog input, control parameter 7-66  
Analog input, list of assignable parameters 7-64  
Analog input, maximum value for adjust 7-66  
Analog inputs  
technical data 5-9  
type 1 5-9  
type 3 5-11  
type 4 5-12  
Analog output 1 7-60  
Analog output 2 7-60  
Analog Output 3 7-72  
Analog Output 4 7-72  
Analog Output 5 7-72  
Analog Output 6 7-73  
Analog output IDN list of assignable parameters 7-75

- Analog output, assignment A, scaling [1/V] 7-74
- Analog output, assignment A, signal selection 7-73
- Analog output, assignment A, signal value at 0V 7-73
- Analog output, assignment B, scaling [1/V] 7-74
- Analog output, assignment B, signal selection 7-74
- Analog output, assignment B, signal value at 0V 7-73
- Analog outputs
  - technical data 5-13
  - type 1 5-13
  - type 2 5-13
  - type 3 5-14
- Application type 7-44
- appropriate use 2-1
- areas (zones)
  - of control cabinet 6-26
- ASCII protocol
  - properties 7-110
- Assign list signal control word 7-47
- Assign list signal status word 7-47
- axis control
  - automatic setting 7-136

## B

- basic performance 1-10
- BASIC PROFIBUS 6-64
- best possible deceleration
  - drive error reactions 1-5
- Best possible deceleration 7-60
- bipolar torque/force limit value 7-23
- Bipolar torque/force limit value 7-40
- Bipolar velocity limit value 7-40
- boring dimensions
  - for the mounting plate 6-2
- Brake supply 6-52
- Braking resistor
  - connection 6-50
- braking resistor HLR 5-17
- braking resistor HLR01
  - dimensions 6-12
- Braking resistor load 7-86
- Braking resistor threshold 7-86
- Build date and time 7-62

## C

- C0100 Communication phase 3 transition check 7-43
- C2000 Command Release motor holding brake 7-80
- C2500 Copy IDN from optional memory to internal memory 7-108
- C2600 Copy IDN from internal memory to optional memory 7-108
- C2800 Analog input adjust command 7-67
- C2900 Command Firmware update from MMC 7-103
- C3200 Command Calculate motor data 7-99
- C4700 Command Activate easy startup mode 7-107
- C5200 Communication phase 4 transition check 7-43
- cable
  - replace 8-23
- Cable
  - IKB 0041 6-66
- Cables
  - motor 6-45
- capacity utilization 4-8
- CE label 1-18
- change single parameter 7-29
- Characteristic of motor magnetizing inductance 7-101
- checksum of parameter values 1-2, 7-2
- clear error 7-18
- clearing error messages 1-5
- closed-loop axis control (closed-loop operation) 7-131
- comfort control panel 7-13

- basic parameters 7-31
- bipolar torque/force limit value 7-23
- change single parameter 7-29
- clear error 7-18
- current configuration 7-22
- cyclic parameter list display 7-21
- diagnostic message memory 7-22
- display mask 7-15
- editing mode 7-14
- enter motor data 7-27
- enter parameter 7-20
- error memory 7-22
- fixed command value 7-28
- guided parameterization 7-25
- keys 7-14
- language setting 7-18
- load basic parameters 7-31
- main screen 7-18
- menu structure 7-16
- mode selection 7-19
- monitor mode 7-19
- motor potentiometer 7-22
- operating hours 7-22
- parameter management 7-31
- parameter selection 7-30
- parameterization 7-24
- save/load parameters 7-32
- single parameter display 7-20
- start screen 7-18
- status switching OM > PM 7-24, 7-29, 7-31, 7-33
- Command value generator output 7-89
- Command value generator, amplitude 7-90
- Command value generator, control word 7-89
- Command value generator, duration 1 7-90
- Command value generator, duration 2 7-90
- Command value generator, list of possible target parameters 7-89
- Command value generator, offset 7-89
- Command value generator, target parameter assignment 7-89
- commands 1-3
  - command types 8-1
- commissioning 7-1
- communication phases 7-4
- compatibility with foreign matters 4-9
- conditions
  - ambient 4-7
  - for installation 4-7
  - storage 4-6
  - transport 4-6
- Config word of axis controller 7-81
- Configuration for loading default values 7-107
- Configuration for starting lockout selector 7-57
- configurations of the control section 1-6
- connection
  - control sections BASIC OPENLOOP 6-61
  - control sections BASIC PROFIBUS 6-64
  - HCS03.1 6-40
- Connection
  - braking resistor 6-50
  - control voltage 6-52
  - control voltage (HCS03) 6-54
  - DC bus 6-56
  - diagram 6-36
  - mains (X3) 6-42
  - motor 6-43
  - motor holding brake 6-48
  - motor temperature monitoring 6-48
- connection diagram
  - HCS02 6-36
  - HCS03 6-37
- Connection point of equipment grounding conductor 6-58
- connections
  - HCS02.1E-W0012 6-38

- HCS02.1E-W0028, -W0054, -W0070 6-39
- control cabinet
  - grounding 6-25
  - with multiple-line structure 6-24
- control loop features 7-132
- control loop setting 7-135
- control loop structure 7-131
- control panels 7-12
- Control parameter of analog output 7-75
- control section
  - connections BASIC OPENLOOP 6-61
- Control section
  - type plate 4-5
- control section configurations 1-6
- Control section type 7-96
- control sections
  - connections BASIC PROFIBUS 6-64
- control voltage
  - data 5-2
- Control voltage
  - connection 6-52
- Control wires
  - shield connection 6-59
- Control word 1 velocity control 7-90
- Control word 2 velocity control 7-94
- Control word of axis controller 7-50
- Control word of current controller 7-54
- Controller type 7-44
- Converter configuration 7-87
- Cooling type 7-84
- copy
  - parameter set 7-32
- current configuration 7-22
- Current load torque 7-80
- Current loop integral action time 1 7-42
- Current loop proportional gain 1 7-42
- Current mains voltage crest value 7-85
- cyclic parameter list display 7-21

## D

- data
  - ambient 4-7
  - electrical, additional components 5-15
  - electrical, power section 5-1
- Data of external braking resistor 7-86
- Data of internal braking resistor 7-87
- data storage 1-1, 7-1
- DC bus 6-56
- DC bus power 7-49
- DC bus voltage 7-49
- Deceleration ramp 1 7-93
- Deceleration ramp 2 7-94
- declaration of conformity 1-18
- definitions of terms 1-1, 7-1
- degree of protection 4-7
- derating 4-8
- Device control
  - control word 7-59
  - status word 7-59
- Device control word 7-98
- devices
  - depths 6-1
  - heights 6-1
  - materials 8-37
  - replacing 8-21
  - widths 6-1
- Diagnostic message 7-41
- diagnostic message memory 7-22
- diagnostic system 8-1
- Digital I/Os, assignment list 7-70

- Digital I/Os, bit numbers 7-71
- Digital I/Os, direction 7-71
- Digital I/Os, outputs 7-72
- Digital I/Os, status display 7-71
- Digital inputs
  - technical data 5-7
- Digital outputs
  - technical data 5-8
- Dimensions 6-1
- Display text of diagnostic message 7-52
- disposal 8-37
- distances
  - for drive controllers 6-3
  - minimum 6-3
- Drive address of master communication 7-98
- Drive address of serial interface 7-98
- drive control commands 1-3
- drive controller
  - distances 6-3
  - replace 8-23
- drive controllers
  - overview 1-6
  - power sections 1-6
- drive functions
  - overview 1-9
- drive profile 7-114
- Drive status word 7-44
- dust, steam 4-7

## E

- editing mode 7-14
- Effective peak current 7-102
- Effective velocity command value 7-54
- electrical data 5-1
- EMC
  - optimal arrangement 6-26
  - rules for design of installations 6-25
- Energy counter 7-86
- enter motor data 7-27
- environmental protection 8-37
- Equipment grounding connections 6-58
- error classes 1-4, 8-2
- error memory 1-5, 7-22
- Error memory of diagnostic numbers 7-62
- Error memory operating hours of control section 7-62
- Error memory power section 7-62
- Error number 7-53
- error reaction
  - drive error reactions 1-5
- errors 1-4
  - drive error reactions 1-5
- E-Stop input 7-67
- E-xxxx errors
  - putting into operation 8-5

## F

- F2xxx errors
  - putting into operation 8-3
- F4xxx errors
  - putting into operation 8-3
- F6xxx errors
  - putting into operation 8-3
- F8xxx errors
  - putting into operation 8-4
- F9xxx errors
  - putting into operation 8-5
- fatal errors
  - putting into operation 8-4

fatal system errors  
  putting into operation 8-5

Field bus  
  baud rate 7-105  
  config. list of cyclic actual value data ch. 7-106  
  config. list of cyclic command value data ch. 7-106  
  control word 7-105  
  control word IO 7-102  
  cycle time (T<sub>cyc</sub>) 7-104  
  data format 7-104  
  diagnostic message 7-104  
  length of cyclic actual value data channel 7-106  
  length of cyclic command value data channel 7-103  
  length of parameter channel 7-106  
  module diagnosis 7-103  
  profile type 7-107  
  status word 7-105  
  watchdog 7-104

Final speed ramp 1 7-91

Firmware  
  type plate 4-5

firmware release update 8-25

firmware replacement  
  possible problems 8-35

firmware version upgrade 8-29

fixed command value 7-28

Flux control loop proportional gain 7-78

Flux-generating current, actual value 7-54

Flux-generating current, limit value 7-97

Flux-generating voltage, actual value 7-56

freely configurable mode 7-116

## G

Ground connection  
  of housing 6-58

ground connections 6-32

guided parameterization 7-25

## H

HAS 6-67

HAS01 6-68

HAS02 6-72

HAS02.1  
  XS2 6-60

HAS05 6-84

history 7-22

Holding brake 6-52

Holding brake control word 7-77

Holding brake status word 7-80

Housing  
  ground connection 6-58

## I

I/O mode (positioning and preset velocity) 7-115

inappropriate use 2-2

installation  
  24V supply 6-35  
  EMC-optimal 6-26  
  in interference-free area of control cabinet (area A) 6-28  
  in strongly interference-susceptible area of control cabinet (area C) 6-30

Installation 6-1, 6-25  
  connection diagram 6-36

installation altitude 4-7

installation conditions 4-7

interface errors  
  putting into operation 8-3

interface mode 7-109

interference suppression elements 6-25  
interference-susceptible area 6-26  
IxR boost factor 7-82

## J

Jerk limit bipolar 7-49

## K

kinds of commands 1-3

## L

L+, L- 6-56  
language  
  setting 7-18  
Language selection 7-46  
line routing 6-25  
List of all operating modes 7-46  
List of diagnostic numbers 7-49  
load basic parameters 7-31  
load defaults procedure 7-9, 7-10, 7-135  
loading parameter values, general 1-2, 7-2  
Lower limit of velocity masking window 7-92

## M

Magnetizing current 7-97  
main screen 7-18  
Mains  
  connection (X3) 6-42  
Mains choke  
  HNL01.1E-\*\*\*\*-S (current-compensated) 5-17  
mains choke HNL01.1E (feeding) 5-16  
mains chokes HNL01.1E  
  dimensions 6-9  
Mains Filter (-Combination) HNK 5-16  
mains filter HNF 5-15  
  dimensions 6-7  
Manufacturer version 7-36  
Marking the components 4-4  
master communication 7-110  
  interfaces 7-3  
Master communication status 7-107  
Master control word 7-43  
materials  
  of products 8-37  
Maximum motor speed 7-43  
Maximum motor voltage 7-79  
Maximum possible continuous current 7-102  
Maximum stator frequency change 7-81  
measuring systems  
  supported measuring systems 1-7  
Memory of velocity command values 7-92  
menu structure 7-16  
Message 'n command > n limit' 7-48  
Message 'n\_actual = n\_command' 7-47  
Message 'nactual < nx' 7-47  
Message 'P >= Px' 7-48  
Message 'T >= Tlimit' 7-48  
Message 'T >= Tx' 7-48  
Message torque/force command value reached 7-51  
Minimum mains crest value 7-85  
mode  
  monitor 7-19  
mode selection 7-19  
Module bus 6-41  
monitor 7-19

- monitoring commands 1-3
- motor
  - motor inductance 1-15
  - replace 8-21
  - requirements on third-party motors 1-14
  - temperature evaluation of third-party motor 1-16
  - third-party, encoder of third-party motor 1-17
  - third-party, notes on commissioning 1-17
  - third-party, notes on selection 1-17
  - third-party, selecting connection technique 1-17
  - third-party, selecting controller 1-17
  - voltage load 1-14
- Motor
  - cables 6-45
  - connection 6-43
  - holding brake 6-48
  - temperature monitoring 6-48
- Motor cable
  - shield connection 6-60
- motor control
  - automatic setting of parameters 7-122
- motor control parameters 7-125
- Motor current at standstill 7-42
- motor encoder data memory 7-9, 7-135
- motor filter HMF 1-15, 5-26
  - dimensions 6-17
- Motor holding brake 6-48
- Motor magnetizing inductance 7-101
- Motor model adjust factor 7-84
- Motor model frequency loop integral action time 7-83
- Motor model frequency loop proportional gain 7-83
- motor parameters 7-124
- Motor peak current 7-42
- motor potentiometer 7-22
  - Motor potentiometer, acceleration 7-94
  - Motor potentiometer, command value 7-95
  - Motor potentiometer, deceleration 7-95
  - Motor potentiometer, step size 7-95
- motor power cable
  - connection to drive controller 6-32, 6-45
  - limited length 5-4
  - shield connection 6-81
  - third-party cables 5-5
- Motor shutdown temperature 7-46
- Motor temperature 7-50
- Motor temperature monitoring 6-48
- Motor type 7-44
- Motor type plate data 7-99
- Motor voltage at no load 7-79
- Motor warning temperature 7-45

motors

- supported motors 1-7
- third-party motors 1-13

Mounting 6-1

mounting plate

- boring dimensions 6-2

## N

- Negative velocity limit value 7-38
- Nominal mains voltage crest value 7-86
- non-fatal errors
  - putting into operation 8-3
- non-volatile data memories 1-1, 7-1
- Non-volatile memory active 7-102
- Number of pole pairs/pole pair distance 7-53

## O

- Oper. hours power section at last activat. of start. lockout 7-58



- operating conditions 4-7
- operating hours 7-22
- Operating hours control section 7-61
- Operating hours power section 7-61
- operating mode 7-4, 7-5
- operating modes
  - basics 1-3
  - positioning block mode 7-137
- Oscillation damping factor 7-82
- overall structure of control loop (illustration) 7-132
- Overload warning 7-75
- Overview of device addresses 7-99

## P

- packaging
  - materials 8-37
- Parallel input 1 7-57
- Parallel output 1 7-57
- parameter handling, general 1-1, 7-1
- parameter management 7-31
- parameter selection 7-30
- parameter set
  - copy 7-32
- parameterization 7-1, 7-12, 7-24
- parameterization mode 7-4, 7-5
- parameters 7-1
  - definitions of terms 1-1, 7-1
  - load 7-32
  - save 7-32
- Parameters 1-1
- performance data 1-10
- Phase current U, actual value 7-56
- Phase current V, actual value 7-56
- positioning block mode 7-137
- Positive velocity limit value 7-37
- power reduction 4-8
- power section
  - type current and type power 5-1
- power sections
  - dimensions 6-1
- Power supply status word 7-87
- Power supply, configuration 7-59
- power voltage
  - supply 5-3
- power voltage supply 5-3
- Premagnetization factor 7-78
- Primary mode of operation 7-36
- products
  - materials 8-37
- profile types
  - freely configurable mode 7-116
  - I/O mode (positioning and preset velocity) 7-115
- putting into operation
  - after fatal error has occurred (F8xxx errors) 8-4
  - after interface error has occurred (F4xxx errors) 8-3
  - after non-fatal error has occurred (F2xxx errors) 8-3
  - after travel range error has occurred (F6xxx errors) 8-3
  - nach after fatal system error has occurred (F9xxx or E-xxxx errors) 8-5

## R

- radio interference suppression
  - general measures 6-34
- Ramp 1 pitch 7-91
- Ramp 2 pitch 7-91
- Rated motor speed 7-100
- Recycling 8-37
- reinforced barking resistors HLR01.1
  - dimensions 6-14

- Relay contacts
  - type 1 5-6
  - type 2 5-6
  - type 3 5-7
- release update 8-24
- replace
  - cable 8-23
  - drive controller 8-23
  - motor 8-21
- replacing the firmware 8-24
  - basic principles, terms 8-24
- Rotor leakage inductance 7-101
- Rotor time constant 7-101
- RS-232/485 Parity 7-108

## S

- safety instructions for electric drives and controls 3-1
- saving parameter values, general 1-1, 7-2
- Scaling of stall current limit 7-78
- Search mode
  - finding point slip factor 7-83
  - search current factor 7-82
- Secondary operation mode 1 7-36
- Secondary operation mode 2 7-36
- Secondary operation mode 3 7-37
- shield connection
  - accessories HAS02 6-72
  - motor cable 6-81
  - with accessory HAS02 6-45
  - without accessory HAS02 6-45
- Shield connection
  - control wires 6-59
  - motor cable 6-60
- shielding plate 6-81
  - motor cable 6-81
- Signal control word 7-45
- signal lines 6-25
- Signal status word 7-45
- single parameter display 7-20
- SIS protocol
  - properties 7-110
- Slip compensation factor 7-82
- Slip increase 7-78
- Square characteristic
  - lowering factor 7-83
- Stall protection loop integral action time 7-82
- Stall protection loop proportional gain 7-81
- standard control panel 7-12
- start screen 7-18
- Stator leakage inductance 7-100
- status machine 7-115
- Status 'n\_feedback = 0' 7-47
- status switching OM > PM 7-33
- Status word of axis controller 7-81
- Status word of current controller 7-54
- Status word of position loop 7-50
- Status word of velocity control mode 7-93
- Status word torque/current limit 7-77
- storage 4-6
  - extended storage 4-6
- strongly interference-susceptible area 6-26
- Switching frequency of the power output stage 7-51
- System time 7-62
- System time error code 7-63
- System time error memory 7-63

## T

- Technical data

- analog inputs 5-9
- analog outputs 5-13
- digital inputs 5-7
- digital outputs 5-8
- temperature
  - ambient 4-7
  - storage 4-6
  - transport 4-6
- Temperature data scaling type 7-46
- Temperature sensor 7-77
- Temperature sensor characteristic 7-77
- Thermal drive load 7-60
- third-party motors 1-13
  - directives 1-13
  - third-party motors to be controlled 1-14
- Time stamp for list of diagnostic message numbers 7-58
- Torque/force constant 7-55
- Torque/force data scaling exponent 7-41
- Torque/force data scaling factor 7-40
- Torque/force data scaling type 7-40
- Torque/force feedback value 7-39
- Torque/force limit value negative 7-39
- Torque/force limit value positive 7-38
- Torque/force peak limit 7-58
- Torque/force polarity parameter 7-39
- Torque/force ramp 7-50
- Torque/force ramp time 7-51
- Torque-generating current, actual value 7-53
- Torque-generating voltage, actual value 7-56
- transition check commands 7-6
- transmission protocols 7-109
- transport 4-6
- travel range errors
  - putting into operation 8-3
- Travel range limit parameter 7-57
- Travel range limit switch inputs 7-67
- Type of construction of motor 7-98
- Type plates 4-4

## U

- Undervoltage threshold 7-58
- Upper limit of velocity masking window 7-92
- use
  - appropriate 2-1
  - inappropriate 2-2

## V

- Vel. cont. loop filter
  - center frequency of band-stop filter 7-88
- Velocity command filter 7-96
- Velocity command value 7-37
- Velocity control loop
  - acceleration feedforward 7-88
  - average value filter clock 7-88
- Velocity control loop filter
  - bandwidth of band-stop filter 7-88
  - filter type 7-87
  - limit frequency of low pass 7-87
- Velocity data scaling type 7-38
- Velocity feedback value 7-38
- Velocity loop integral action time 7-41
- Velocity loop proportional gain 7-41
- Velocity loop smoothing time constant 7-52
- version upgrade 8-24
- vibration
  - noise 4-7
  - sine 4-7
- vibrations 4-7

Voltage boost 7-81  
voltage load of the motor 1-14  
Voltage loop integral action time 7-79  
Voltage loop proportional gain 7-78

## W

warning classes 1-4, 8-2  
warnings 1-4

## X

X1 6-41  
X13 6-52  
X3 6-42  
X5 6-43  
X6 6-48  
X9 6-50  
XS1 6-59  
XS2 6-60

## Z

Zubehör  
Übersicht 6-67



**Rexroth**  
Bosch Group

Bosch Rexroth AG  
Electric Drives and Controls  
P.O. Box 13 57  
97803 Lohr, Germany  
Bgm.-Dr.-Nebel-Str. 2  
97816 Lohr, Germany  
Phone +49 (0)93 52-40-50 60  
Fax +49 (0)93 52-40-49 41  
service.svc@boschrexroth.de  
www.boschrexroth.com



R911314905

Printed in Germany  
DOK-INDRV\*-FU\*\*\*\*\*-IB01-EN-P