

Frequency inverter

series FBS / FDS

Installation and start-up instruction

Read these instructions before installation and start-up !

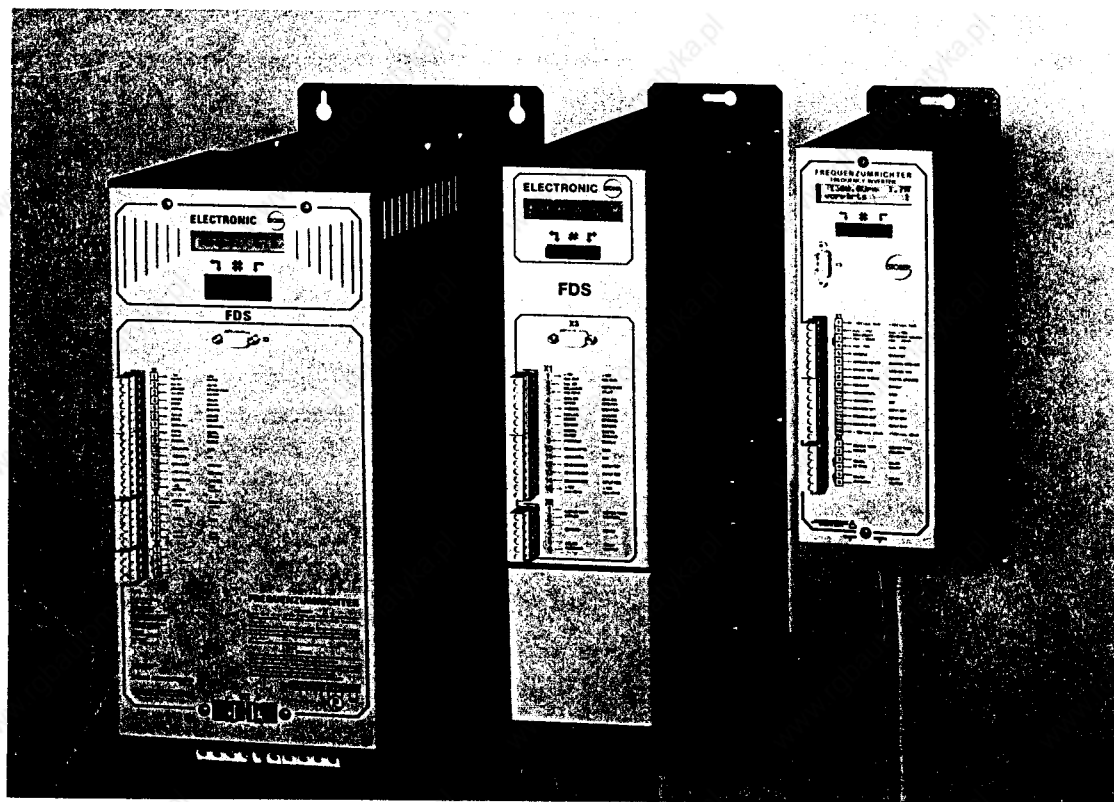

SW - V 3.2



1995



Inhaltsverzeichnis

Safety Precautions 1

Technical Data 2

Design Indications 4

 Principle drive drawing 4

 U/f-characteristic 5

 Conduction at load condition 6

 Dimensioning 6

 Overload capacity 7

 Determination of motor connection and gear factor 8

 Dimensioning breaking resistance 8

 Correspondence MGS-system motors to FDS frequency inverters 9

Mechanical Installation 10

Electrical Installation 11

 Connectors power circuit 11

 EMC-fulfil mounting and wiring 12

 Connectors control unit 13

Commissioning 17

Drive Working Conditions 18

Mimic diagram for adjustment and display 20/21

Man-Machine-Communication 22

 Adjustment and operation by display and keyboard 22

 Choosing a parameter set for adjustment 22

 Selecting of parameter sets 22

 FDS-TOOL, Parabox 23

Groups, Parameter, Values 24

 Motor data 26

 Machine data 27

 Set-point adjustment 29

 Fix set-points 31

 Ramp generator 31

 Stop-functions 32

 Customer interface 32

 Display values 34

 Operation 34

 Actions 35

 Data transfer between FDS and Parabox 35

 Device data 36

Messages, Warnings, Faults 37

Interference elimination 38

Junction cable PC-FDS 38

Parabox 38

Accessories 39

Programming example 40

Data sheet 41

Modular mimic displays 42/43

Voltage test of electrical installation 44

Additions

STÖBER ANTRIEBSTECHNIK - Germany

STÖBER ANTRIEBSTECHNIK - International

**Safety Precautions**

The FDS series of frequency inverters are an electrical device to control motor speed of asynchronous motors by regulating the electrical current. The handling, installation, maintenance and operation must be done only by following these instructions as well as local, state and federal regulations for electrical equipment.

The strict observation of these requirements and specification is a responsibility of the customer.

To avoid problems caused by incorrect use, make sure you read the complete operating instructions before installing and operating.

Caution! High Voltage! Electric shock! Danger of life

For safety- and warranty reasons it is not admitted to open the FDS inverter unit. A faultless use of the entire drive is only possible when projected properly.

**Take care of:**

- System of protection: earthing; operation only with correct earth lead.
- Fault Current (FI)- Protective Switches cannot be operated in combination with the frequency inverter (VDE 0160).
- Work at the FDS may not be done without insulated tools.
- No installation as long as the frequency converter is connected to the mains. During work at the drive disconnect the main supply, not only lock the "enable" signal.
- Capacitor discharging time > 7 minutes.
- Lacquer sealed screws must not be operated or removed for they fulfil important protection functions.
- Penetrating the frequency inverter with any kind of object is forbidden.
- Cover the top of the FDS frequency inverter during installation and while other work is done in/around the enclosure. Metal parts can cause short cuts inside the FDS frequency inverter.
- Before initiation remove all covers from the FDS frequency inverter, to avoid overtemperature of the device.



Stöber Antriebstechnik is not liable for any damage done by not following these instructions or other local and state requirements.



Technical Data	FBS 2008/B	FBS 2013/B	FDS 2014/B	FDS 2024/B
max. output power at S1	0.8 kVA	1.3 kVA	1.4 kVA	2.4 kVA
Recommended motor shaft power	0.37 kW	0.75 kW	0.75 kW	1.5 kW
Supply voltage U_{min} - U_N - U_{max}	(L1-N) 1×120-230-275V/50Hz/60Hz		(L1-L3) 3×200-400-440V/50Hz/60Hz	
Output voltage U_A	3×0-230V~ (with 230V~supply)		3×0-400V~ (with 400V~supply)	
Output frequency	0 - 200Hz			
Nominal current I_N at S1	3 × 2.1 A~	3 × 3.5 A~	3 × 2.1 A~	3 × 3.5 A~
Dynamic overload I_{max}	1.5 × I_N (ED: 0.5 max. 30s)			
Mains fuse	1×6.3AT	1×10AT	3×6.3AT	3×6.3AT
Device efficiency η	ca. 98% at nominal operation			
Stray power at nominal operation	ca. 30 W	ca. 40 W	ca. 50 W	ca. 60 W
Clock frequency	4 kHz (+n×2 kHz)			
Set-point "ref.-val." inputs - for voltage X1.2 - for current X1.2 + X1.3 - for frequency X1.14	0 ... ±10V / Input resistance $R_E = 25k\Omega$ 0 (±4) ... ±20mA / Input resistance $R_E = 500\Omega$ 0.1 kHz ... 3.0 kHz accuracy: ±1%			
Voltage supply - for Set-point "ref.-val."	+10V ±5% / 3mA			
- for digital signals	+12V +10% / 20 mA			
24V-voltage supply (X7.1, X7.2) Input voltage range Input current	-			
Serial Interface	RS-232-C			
Binary inputs (enable, clockwise cw, counter clockwise ccw, BE1, BE2, BE3) according to DIN 19240	Logic level:	not conn. = L-Level < +8V = L-Level > +12V = H-Level	Voltage limits: -10V / +32V Jamming resistance acc. to IEC 801-4	
Reaction time of binary inputs	4 ms			
Analog Output	0 ... ±10V ±5% / $R_i = 1k\Omega$ (adjustable to ±1% by offset and skaling)			
TMS-tripping device (Total motor protection) Connector for motor temperature probe	potentialfree, 1 - 6 Posistor, DIN 44081			
Ready message / Relay output 2	Relay contact (without protection circuit), max. 6A/250V~ 6A/30V resistive load; 1A/30V inductive load L/R = 40ms minimal current: 10mA; switching time ca. 10ms			
Braking resistance R_b internal: (only at B-Version)	-			
Braking resistance R_b external:	$R_b = 300\Omega$ max. 0.5 kW		$R_b = 300\Omega$ max. 1.5 kW	
Protection class according to DIN 40050	IP 20			
Radioshielding	EN 55011 class B			
Jamming resistance accord. to VDE 0843	part 2 (ESD class 4); part 4 (burst degree 4)			
Power connector (X11)	Pin-socket connector (Combicon) 9-pole, max. \varnothing 2.5mm ²		Pin-socket connector (Combicon) 10-pole, max. \varnothing 2.5mm ²	
Signal connector	Pin-socket connector (Combicon) 8 + 7-pole (X1), 6-pole (X2), max. \varnothing 2.5mm ²			
max. length of motor cable - shielded - unshielded	30m 80m extended length on request			
MMC	(Man Machine Communication) 3 keys, display with 2×16 characters, Serial interface RS-232-C			
Operating ambient temperature	0 ... +45 °C at I_N			
Storing temperature	-20 ... +70 °C			
Dimensions in mm (w × h × d)	100 × 300 × 176			
Weight	ca. 3.2 kg	ca. 3.2 kg	ca. 3.2 kg	ca. 3.2 kg



Technical data	FDS 1030/B	FDS 1040/B	FDS1070/B	FDS 1085/B	FDS 1110 FDS 1110/B	FDS 1150 FDS 1150/B	FDS 1200 FDS 1200/B
max. output power at S1	3 kVA	4 kVA	7 kVA	8.5 kVA	11 kVA	15 kVA	20 kVA
Recommended motor shaft power	1.1-1.5kW	1.1 - 2.2 kW	3.0 - 4.0 kW	5.5 kW	7.5 kW	11.0 kW	15.0 kW
Supply voltage (L1 - L3)	3 × 400V~ +10/-15% 50/60Hz				3 × 400 - 480V~ ±10% 50/60Hz		
Output voltage U _A	3 × 0 - 400V~ (with 3 × 400 - 480V supply)						
Output frequency	0 - 150Hz						
Nominal current I _N at S1	3 × 4.1 A~	3 × 5.5 A~	3 × 10.0 A~	3 × 12.0 A~	3 × 16.0 A~	3 × 22.0 A~	3 × 32.0 A~
Dynamic overload I _{max}	1.5 × I _N (ED: 0.5 max. 30s)						
Mains fuse	3 × 10 AT		3 × 16 AT		3 × 25 AT	3 × 35 AT	3 × 63 AT
Device efficiency (η)	ca. 95%	ca. 95%	ca. 95%	ca.95%	ca.95%	ca.95%	ca.95%
Stray power at nominal operation	ca. 80W	ca. 100W	ca. 170W	ca. 220W	ca. 330W	ca. 440W	ca. 560W
Clock frequency	3.0 kHz (bis 9.9 kHz)						
Set-point "ref.-val." inputs - for voltage X1.2 - for current X1.2 + X1.3 - for frequency X1.14	0 ... ±10V / R _e = 25kΩ 0 (±4)... ±20mA / R _e = 500Ω 0.1 kHz ... 3.0 kHz						
Voltage supply - for set-point "ref.-val." - for digital signals	+10V ±10% / 3mA				+16V - 24V ±10% / 80mA		
24V-voltage supply (X7.1, X7.2) Input voltage range Input current	-				20.4V - 28.8V max. 1A		
Serial interface	RS-232-C						
Binary inputs (enable, clockwise cw, counter clockwise ccw, BE1, BE2, BE3) acc. to DIN 19240	Log. Level: not conn. = L-Level < +8V = L-Level > +12V = H-Level				Voltage limits: -10V / +32V Jamming resistance acc. to IEC 801-4		
Reaction time of binary inputs	8ms						
Analog output	0 ... ±10V ±10% / R _i = 1kΩ (Offset and scaling adjustable)						
TMS-tripping device (Total motor protection) Connector for motor temperature probe	potentialfree, 1 - 6 Posistor, DIN 44081						
Ready message / Relay output 2	Relay contact (without protection circuit), max. 6A/250V~ 6A/30V resistive load; 1A/30V inductive load L/R = 40ms minimal current: 10mA						
Braking resistance internal: (only at B-Version)	-				R _b =80Ω /250W max. 7.2kW	R _b =29Ω / 250W max. 19.9kW	
Braking resistance external: (only at B-Version)	R _b ≥ 100Ω , max. 2.6 kW				R _b ≥39Ω; max. 14.8kW	R _b ≥29Ω; max. 19.9kW	R _b ≥14.5Ω, max. 39.8kW
Protection class acc. to DIN 40050	IP 20						
Radioshielding acc. to EN 55011	class B with accessories EMC-Pack				class B		
Jamming resistance acc. to DIN 0843-4	4kV						
Power connector	Pin-socket connector (Combicon) 10-polig, max. Ø 2.5mm ²				Terminal screw 10-pole, max. Ø 10mm ²		
Signal connector	Pin-socket connector (Combicon) 8 + 7 + 6-pole, max. Ø 2.5mm ²				Pin-socket connector (Combicon) 7+8+6+4-pole, max. Ø 2.5mm ²		
max. length of motor cable - shielded - unshielded	with accessories EMC-Pack 30m 100m 80m 300m extended length on request				100m 300m extended length on request		
MMC	(Man Machine Communication) 3 keys, display with 2 × 16 Characters, Serial interface RS-232-C						
Operation ambient temperature	0 ... +45°C at I _N						
Storing temperature	-20 ... +70°C						
Dimensions in mm (w × h × d)	100 × 300 × 270				189 × 415 × 270		
Weight	ca. 5.7 kg	ca. 5.7 kg	ca. 6.0 kg	ca. 6.0 kg	ca. 16.0 kg	ca. 16.0 kg	ca. 16.3 kg

Frequency Inverter FDS

Motor

Gear

Machine/Process

Nominal output current I_{FUN}
Nominal output voltage 400V

with K = relative operating time of the breaking resistance

$$P_{RB} = \frac{U_{ZK}^2}{R_B^2} \cdot K$$

für $0 \leq K \leq 1$

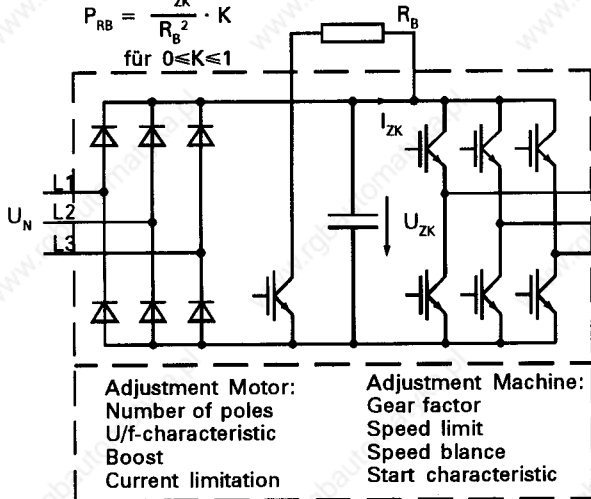

Nominal current: I_{MN}
Nominal voltage: U_{MN}
Nominal frequency: f_{IN}
Number of poles: p

Type 1: $M = \text{const}$
Type 2: $M \sim 1/n$
Type 3: $M \sim n$
4: Breakaway torque

$$P_1 = \sqrt{3} \cdot U_1 \cdot I_1 \cdot \cos \varphi$$

$$P_M [\text{kW}] = \frac{M_M \cdot n_M}{9550}$$

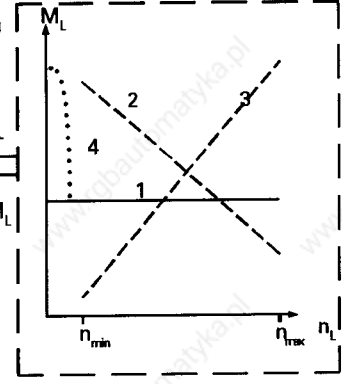

Connection of winding

Transformation to motor shaft:

$$U_M \sim n_M$$

$$I_M \sim M_M$$

$$\frac{n_M}{n_L} = i$$

$$\frac{M_M}{M_L} = \frac{1}{i}$$

$$J = \frac{J_L}{i^2}$$

Operating range: $\frac{n_{max}}{n_{min}}$

Principle Drawing: Drive consisting of FDS frequency inverter, asynchronous motor, gear and machine

Torque-speed-characteristic of the drive

The machine respectively the process demands a definite torque in dependence upon the speed. The characteristic of torque and speed depends on the type of machine used. For example: With winding engines the torque is nearly independent of the speed. Engines with constant power like saws or spindles need less torque with increasing speed, whereas pumps and fans increase their torque demand with increasing speed. The starting of a drive may also demand an increased torque.

Gear

The machine is driven in a definite speed range which is provided by a minimum and maximum operation speed. By means of a gearing the motor speed is adjusted to the machine. In this way the speed, torque and mass moment of inertia is transformed with the gear factor to the motor.

To achieve the optimum adaption of motor, gear and machine all system parameters need to be adjusted at the FDS frequency inverter.

Frequency controlled asynchronous-machine: Characteristic of motor voltage and motor current at nominal load

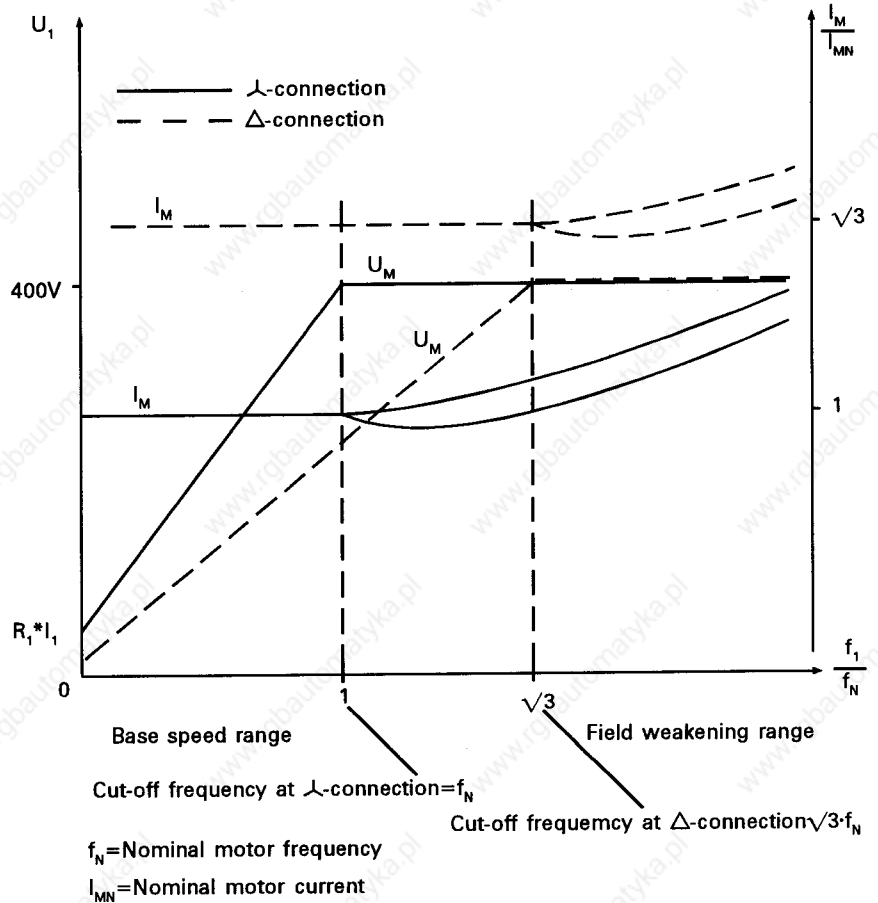

The motor transforms electrical energy into mechanical energy. The size of the motor refers in principal to the machine torque demanded.

U/f-characteristic

Δ/Δ -connection

The curve of the motor voltage and motor current indicates the range of a constant torque (base speed range) and constant power (field weakening range). In the base speed range the voltage increases proportional with the speed and frequency. The maximum of the motor voltage is delivered at the cut-off frequency f_c . The normal cut-off frequency is 50Hz. To increase the cut-off frequency up to 87 Hz the motor (230/400V-50Hz D/Y) needs to be delta connected and the voltage curve in the FDS frequency inverter adjusted. In comparison to the star connection the motor delivers in triangle connection the power at the same speed, less voltage but higher current. Now the U/f-characteristic can be linear expanded from the nominal point (230V/50Hz) up to (400V/87Hz). The motor gives off its nominal torque within the 87Hz. Therefore the maximum motor power rises by the factor 1.7 compared to the star connection with the cut off-frequency of 50Hz. It needs to be secured, that the FDS frequency inverter is designed for that power. The output current of the FDS frequency inverter therefore must be 70% higher than the output current of the star connection.

Boost

At the frequency 0Hz the U/f-characteristic does not relate to the zero point, but the voltage increase (boost) delivers a sufficient drive torque at low speed.

Motor current, $\cos \varphi$ and speed drop in dependence of the load (motor operation temperature)

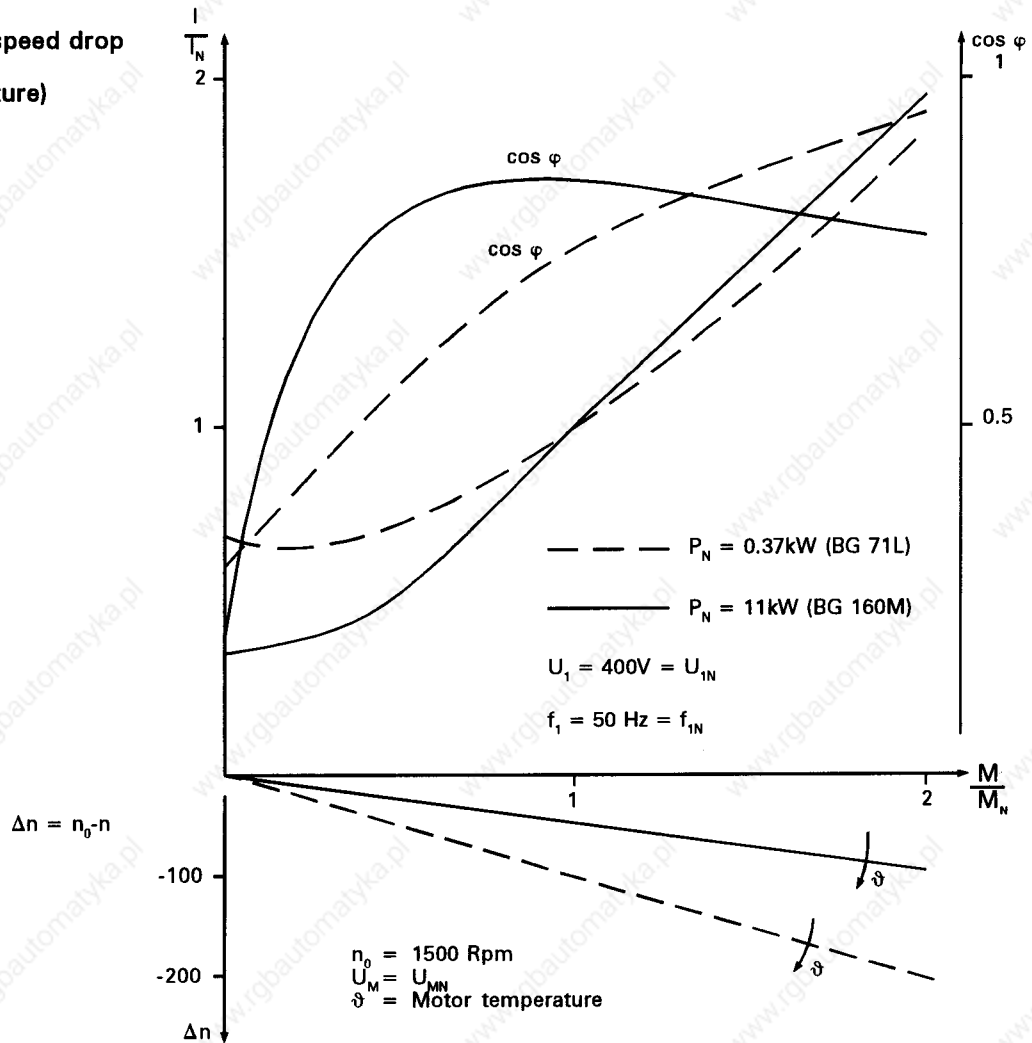

Conduction at load condition
Motor current, speed drop

The voltage supplied by the FDS frequency inverter is of symmetric three-phase shape with its amplitude U_1 and frequency f_1 . A rising drive load causes higher motor current and a definite amount of speed drop (Δn). In the partial load range ($M < 0.5 M_N$) there is no linear relation between a current rise and a rise of torque. The torque in this range is originated by an improved power factor. This effect is more distinct with small motors as well the speed drop with rising load, which is shown in a more flat working characteristic. Bigger motors have got less speed drop. The temperature has got a great impact on the steepness of the working characteristic. At higher temperature we also have a higher speed drop, this results in a more flat working characteristic.

Dimensioning
Shorttime overload

The main factor for dimensioning a motor is the torque needed. Regard is to be paid for the static torque, dynamic torque (acceleration), load push and the initial breakaway torque and depend on the application an increased safety factor. In consideration of these shorttime loads it needs to be verified, if the drive is to be dimensioned for this higher load or if the drive can work the load within a shorttime period overstressed. Therefore it is necessary to know the high and the duration of the overload stage. The FDS frequency inverter has to perform these requirements. If the duration of an overload stage is expanded over several minutes, the thermal time constant of the motor is to be considered.

Overload capacity

A_N = Drive nominal point at 50Hz cut-off frequency

A_N^* = Drive nominal point at 87H cut-off frequency

n_0 = Synchronous speed

$$= \frac{f_1 \cdot 120}{p}$$

n_{N0} = Synchronous speed at nominal frequency

Operation range: $\frac{n_{max}}{n_{min}}$

**) The two limiting values depend on the ratio between nominal device and motor current caused by the display of nominal referred values.

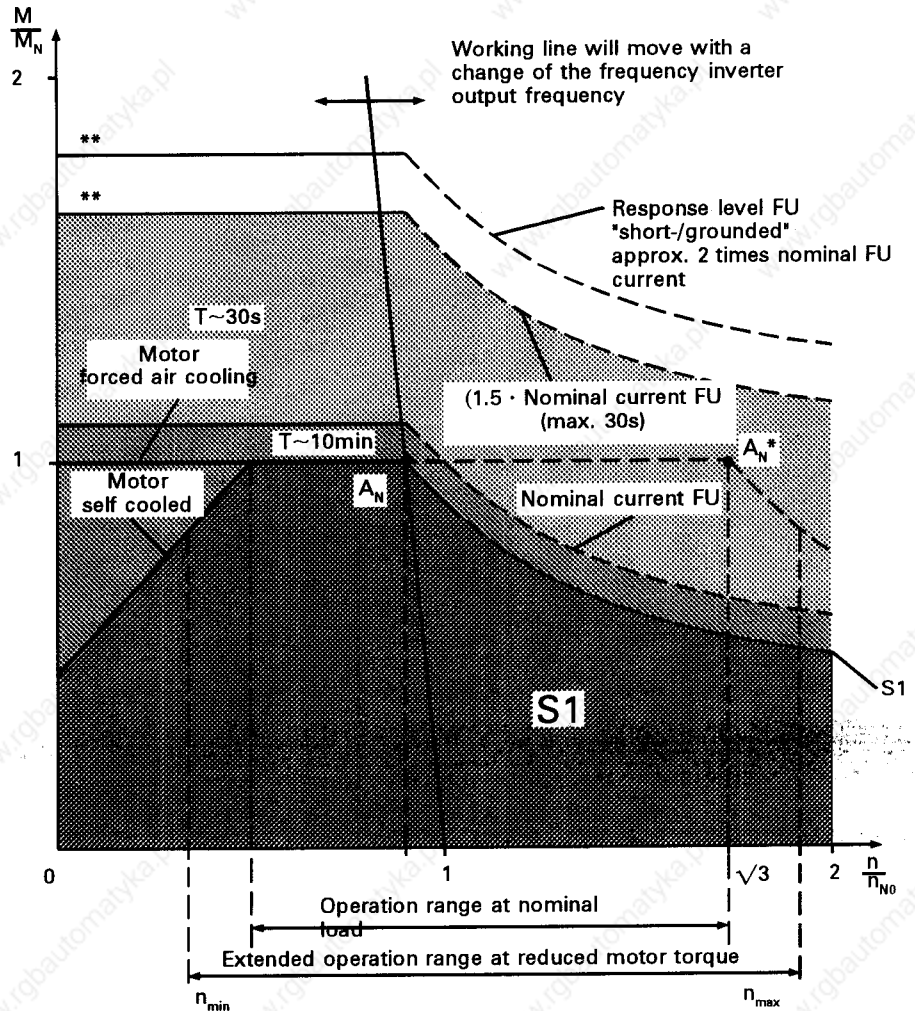

Motor overload capacity

With correct adjusted FDS frequency inverter, the motor can, even at slow speed, originate two times his nominal torque. The increased current demand during an overload stage effects a stronger warm up of the motor. The thermal time constant of the motor is about 10 minutes. An overload duration of approx. 1 minute is therefore unproblematic, if the average load is beneath the nominal load.

Frequency inverter overload capacity

To achieve a certain amount of drive overload the FDS frequency inverter needs to be able to deliver the higher motor current. The frequency inverters of the FDS series can be shorttime overloaded. The FDS frequency inverter supplies 1.5 times of his nominal current during 30 seconds. Load peaks causing a motor current higher than 200% of the FDS nominal current produce the fault "short-/grounded" at the FDS frequency inverter display.

See:

- Motor Data
- Current limitation page 26
- Message, Warning, Fault
- Fault, short-/grounded page 37

Posistor-tripping device (TMS-tripping device)

The FDS frequency inverter is protected against thermal overload caused by too high output current or insufficient cooling. With dynamic or slow speed drives it is recommended to have a thermal control by means of the FDS integrated posistor-tripping device.

See:

- Electrical Installation
- Connection of motor temperature probe page 16



Determination of motor connection and gear factor

The set of the gear factor and the choice between triangle or star connection form a unit, in which the choice of the motor connection method and cut-off frequency influence the speed of maximum power. This determination depends on the load characteristic curve of the machine.

With a load type $M = \text{constant}$ or $M \sim n$, the cut-off frequency should be as high as possible. That means, motor connected in triangle and the nominal point adjusted to 400V/87Hz. The equation for calculating the gear factor:

$$i = \frac{f_{1E} [\text{Hz}] \cdot 120 [\text{Upm/Hz}]}{p \cdot n_{Lmax} [\text{Upm}]} \quad \left| \quad \begin{array}{l} f_{1E} = 87\text{Hz} \\ 50\text{Hz} \end{array} \right.$$

- p = Number of poles
- n_{Lmax} = Maximum speed of the machine

With a load type $M \sim 1/n$, the cut-off frequency should be as low as possible. That means, motor connected in star and the nominal point adjusted to 400V/50Hz. The gear factor is set to the maximum possible motor speed or the maximum gear enter speed.

$$i = \frac{n_{max}}{n_{Lmax}}$$

- n_{Mmax} = Maximum admissible motor speed resp. Gear input speed
- n_{Lmax} = Maximum admissible machine speed

Drive speed operation range

By means of the gear factor and the equation for converting torque and speed upon the motor shaft (Page 3), the M-n-characteristic is to be converted upon the motor shaft.

With the setting of the motor connection method and the gear factor the speed operation range is fixed. Therefore it is to be checked if the speed operation range respectively the demanded torque throughout the speed operation range is sufficient. That can be done by the converted load characteristic and the M-n-characteristic of the motor. By increasing the gear factor the motor torque reduces, this provides a wider speed operation range. Now the drive can run with higher speed but less torque (field weakening range of the motor) but also deliver a higher torque at slower speed and still accomplish the demand of the drive.

See:

Design Indications
Figure page 7

Dimensioning braking resistance

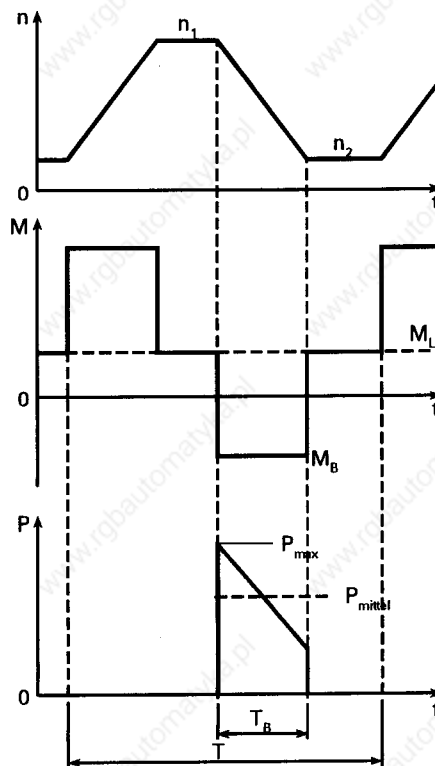

Units:

- n = Speed in min^{-1}
- M_B = Braking torque in Nm
- M_L = Load torque in Nm
- P = Power in W
- J = Mass moment of inertia of the entire drive in kgm^2
- T = Cycle time in seconds
- T_B = Braking time in seconds
- η = Efficiency in %
- U_s = Switching threshold in V
FDS 1040/B - FDS 1085/B : 750V
FDS 1110(B) - FDS 1200(B) : 800V
- R_B = Braking resistance in $\Omega \eta \mu$

Braking Power

$$M_B = \frac{J \cdot (n_1 - n_2)}{9.55 \cdot T_B}$$

$$P_{max} = \eta \cdot \omega_1 \cdot M_B = 0.084 \cdot n_1 \cdot M_B$$

$$P_{mittel} = 0.042 \cdot (n_1 + n_2) \cdot M_B$$

Braking Resistance:

$$R_{Bmin} < R_B < 7.6 \cdot \frac{U_s^2}{M_B \cdot n_1}$$

$$P_{Rmittel} = 0.042 \cdot (n_1 + n_2) \cdot M_B \cdot \frac{T_B}{T}$$

Type	P _N [kW]	M _N [Nm]	n _N [rpm]	Connection	U _N [V]	I _N [A]	M _w /M _N	Boost for I _N [%]	J [kgm²]	T _B [s]	nom. device current nom. motor current															
											1	2	3	4	5	6	7	8	9	10	11	12				
71K	0.25	1.75	1380	△ / Ʒ	230/400	1.50/0.8	2.10	43	0.0004	0.036																
71L	0.37	2.55	1380	△ / Ʒ	230/400	1.90/1.1	2.30	34	0.0005	0.033																
80K	0.55	3.70	1390	△ / Ʒ	230/400	2.60/1.5	2.20	35	0.0013	0.055																
80L	0.75	5.00	1410	△ / Ʒ	230/400	3.30/1.9	2.50	26	0.0017	0.053																
90S	1.1	7.40	1420	△ / Ʒ	230/400	4.60/2.6	2.60	23	0.0030	0.064																
90L	1.5	10.00	1430	△ / Ʒ	230/400	6.15/3.5	2.90	23	0.0038	0.058																
100K	2.2	15.00	1410	△ / Ʒ	230/400	8.85/5.1	3.20	19	0.0048	0.051																
100L	3.0	20.30	1420	△	400V	6.50	3.30	51	0.0061	0.047																
112M	4.0	27.00	1420	△	400V	8.60	3.20	41	0.0097	0.057																
132S	5.5	36.50	1440	△	400V	11.60	2.80	37	0.0263	0.111																
132M	7.5	50.00	1440	△	400V	15.50	2.90	29	0.0325	0.103																
132L	9.2	61.00	1440	△	400V	20.00	2.90	31	0.0400	0.103																
160M	11.0	72.40	1450	△	400V	22.00	2.60	29	0.0525	0.116																
160L	15.0	98.00	1460	△	400V	29.00	2.80	31	0.0675	0.109																

	3x2.1 A eff.	3x3.5 A eff.	3x2.1 A eff.	3x3.5 A eff.	3x5.5 A eff.	3x10 A eff.	3x12 A eff.	3x16 A eff.	3x22 A eff.	3x32 A eff.
FBS 2008										
FBS 2013										
FDS 2014										
FDS 2024										
FDS 1040										
FDS 1070										
FDS 1085										
FDS 1110										
FDS 1150										
FDS 1200										

Table:
Correspondence MGS-system motors to FDS frequency inverters

The table contains the most important ratings of 4-pole asynchronous motors in the power range between 0.25KW and 15KW.

The column "Boost for I_N" contains a setting for the Boost at slow speed which is recommended. With this adjustment the motor delivers his maximum torque even at slow speed.

The correspondence matrix between MGS-system motors and FDS frequency inverters enables to choose the adequate equipment for each application. The fields marked grey show the recommended combinations of motors and frequency inverters. Each field contains an additional value indicating the ratio between the nominal frequency inverter current and the nominal motor current. The additional overload capacity of 50% for 30 seconds is not included in this value.

For the dynamic evaluation of the drive the motor mass moment of inertia and the theoretical acceleration time at nominal torque up to nominal speed is to be taken in consideration. With this data and the specifications of gearing and machine the needed acceleration torque can be calculated with the following equation. The equation is valid for accelerations slower than 300ms.

$$\frac{M_B}{M_N} = \frac{\Delta n}{n_N} \cdot \frac{T_B}{T} \left(1 + \frac{J_L}{J_M} \cdot \frac{1}{i^2} \right)$$

M_N = Nominal motor torque
 M_B = Demanded dynamic torque
 J_M = Motor mass moment of inertia

J_L = Machine mass moment of inertia
 i = Gear factor
 T_B = Calculated motor run-up time with nominal torque to nominal speed
 T = Designated run-up time Δn



Mechanical Installation

Attachement

Rapid mounting

Enclosure climate

The FDS frequency inverter has to be mounted into an enclosure vertical because of thermal conditions. The unit must be mounted with a clearance of 4 inches on top and bottom and 2 inches from the sides of other units.

According to the figures shown beneath, the attachment of the device is to be done with screws M5 and plain washers.

The FDS frequency inverters provide a rapid mounting facility which means, that the device can be mounted or dismantled by untying the fastening screws. When using the rapid mounting facility assure to leave the hatched space, shown in the figures, from the top down to the bottom end of the device.

The allowable ambient temperature range is from 32°F (0°C) to 113°F (+45°C). Temperature extremes are not admissible because of moisture build up.

To avoid moisture build up and to keep the temperature in the allowable range a heater or ventilation can be added. Therefore it is recommended to install a temperature control device.

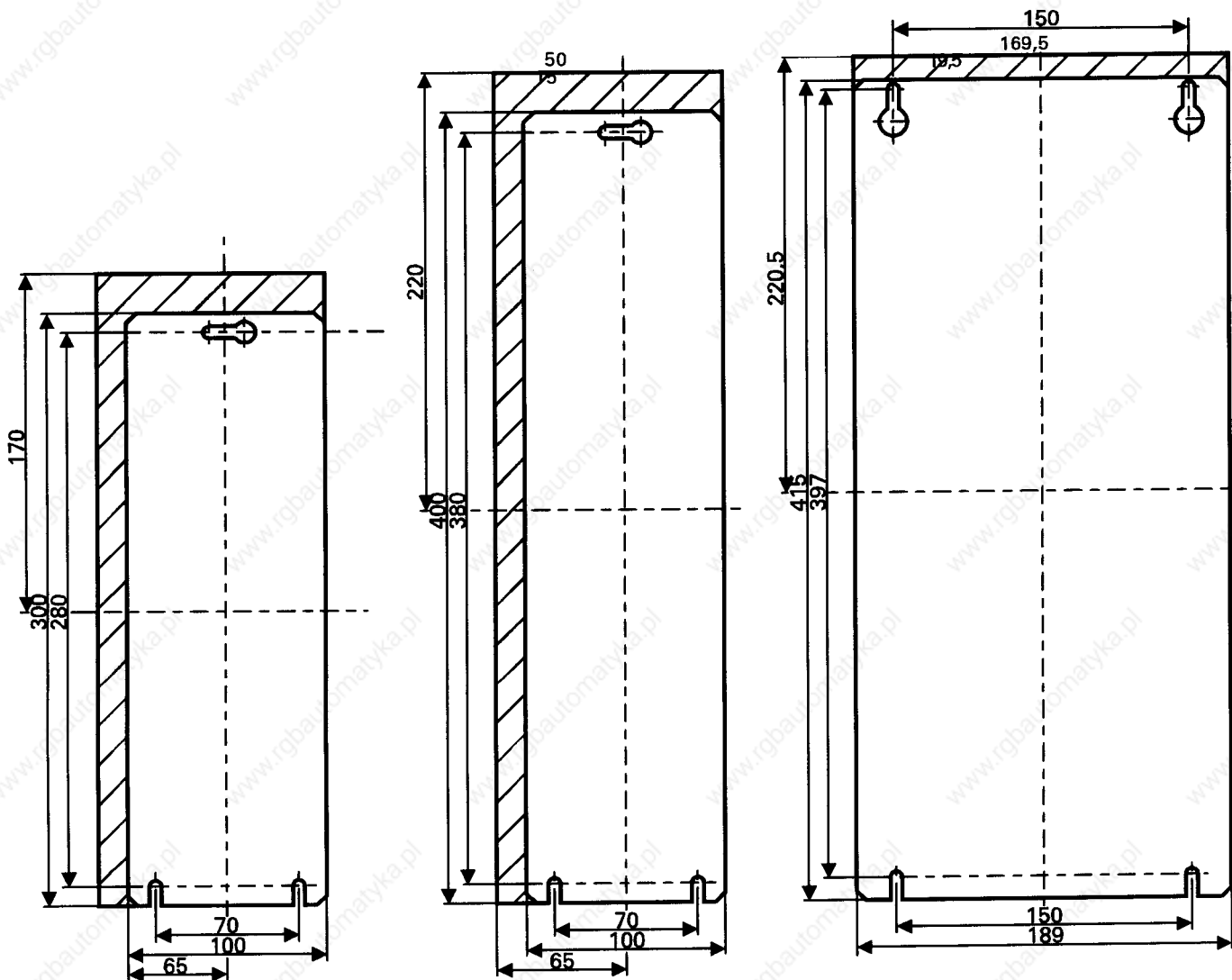

FBS 2008/B, FBS 2013/B
 FDS 2014/B, FDS 2024/B
 FDS 1030/B, FDS 1040/B
 FDS 1070/B, FDS 1085/B

FDS 1030/B with EMC-Pack
 FDS 1040/B with EMC-Pack
 FDS 1070/B with EMC-Pack
 FDS 1085/B with EMC-Pack

FDS 1110 (/B)
 FDS 1150 (/B)
 FDS 1200 (/B)

Electrical installation



The installation of the FDS frequency inverter must only be done by experienced personnel per electrical schematic. Signal and control wires should be run separate from the main supply and motor cable. The protection class has to be protective earthing.

The frequency inverter is for the use with AC asynchronous motors only. The operation of the FDS frequency inverter is permitted only with earthing wire. Fuses should only be used at the entrance cable per technical data (see: 'Technical Data' pages 2,3).

connectors power circuit (X11)

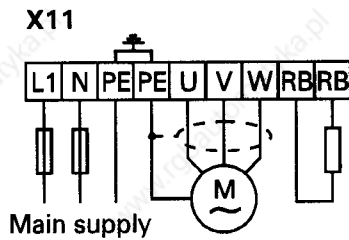

Connecting plan FBS 2008/B, FBS 1013/B

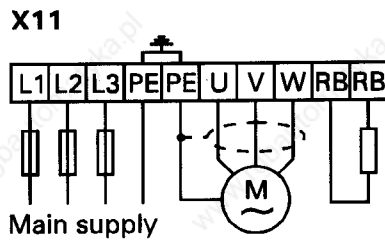

Connecting plan FDS 2014/B, FDS 2024/B, FDS 1040/B - FDS 1200/B

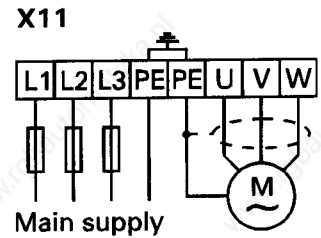

Connecting plan FDS 1110 - FDS 1200

See:

Electrical Installation
EMC-fulfil mounting and wiring page12

Conductor cross-section and fuse protection

Minimum recommended cross-section of main- and motor cable, Fuse protection main supply cable:



	FBS 2008/B	FBS 2014/B	FDS 2014/B	FDS 2024/B	FDS 1040/B	FDS 1030/B	FDS 1070/B	FDS 1085/B	FDS 1110	FDS 1150	FDS 1200
Cross-sect. [mm ²]	1.5	1.5	1.5	1.5	1.5	1.5	2.5	2.5	2.5	4.0	6.0
Main-Fuses	1 × 6.3 AT	1 × 10 AT	3 × 6.3 AT	3 × 6.3 AT	3 × 10 AT	3 × 10 AT	3 × 16 AT	3 × 16 AT	3 × 25 AT	3 × 35 AT	3 × 63 AT

Braking resistor

The FDS series 1XXX/B fitted with a braking module is suitable for limited 4-quadrant operation. The control electronic is installed in the FDS 1040/B - 1085/B, the braking resistor is mounted outside the frequency inverter and connected at the terminals RB (see Electrical Schematic FDS 1040/B - 1200/B).

The FDS series 1110/B - 1200/B contains the control electronic as well as the braking resistor. To increase the braking power an additional braking resistor is to be installed at the terminals RB (see Electrical Schematic FDS 1040/B - FDS 1200/B).

See:

Technical Data
Maximum length of motor cable pages 2, 3
Commissioning
Check of motor conduit box page 17
Design Indications
Dimensioning of the braking resistance page 8



EMC-fulfil mounting and wiring

In order to avoid parasitic radiation and net interaction the wiring should be made as described in the measurements listed below. These facts combined with the use of EMC-pack (for FDS 1040/B - FDS 1085/B) resp. already integrated filters (at FDS 1110/B) - FDS1200(B)) ensure the observation of EN 55011/B.

Regulated cable

- The control cables shall be run separated from the main supply cable, motor cable and breaking resistance cable in order to avoid inductiv and capacitive bunching.
- The main supply cable and the motor cable shall be run separately. Use shielded motor cable (EN55011/B).
- The main supply cable can either be shielded or unshielded.
- The cable for the breaking resistor shall either be two twisted wires or a shielded cable with less than 2m.

Central earthing point

- Next to the FDS frequency inverter there has to be a central earthing point, for example the mounting plate of the enclosure. All shields are to be connected large surfaced with a metal strap which can also be used for fixing the cable (see figure beneath). The earth wire of main supply and motor and the two FDS earth wires are to be connected at the same point.

Shield connections

- The motor cable shield is to be earthed on both sides.
- The shields at the frequency inverter are to be connected like described above.
- The motor cable shield is to be connected large surfaced as near as possible to the conduit box. It can also be mounted to the mounting plate of motor or gear if there is good conducting to the earth wire. The shield of the motor cable fulfils a different function than the earth wire. Therefore the earth wire needs to be connected at the conduit box.

The shields of the main supply cable, control cables and cable of the breaking resistance shall be fixed at an earthed metal plate.



Additional PE-terminal

The ground contact current of the devices FDS 2008/B - FDS 2024/B are higher than 3.5mA. Refer to the VDE 0160 for ground contact current greater then 3.5mA. The PE-terminal at the lower end of the mounting plate offers the possibility of connecting a second protective earth cable, as recommended in the VDE 0160.

Incorrect

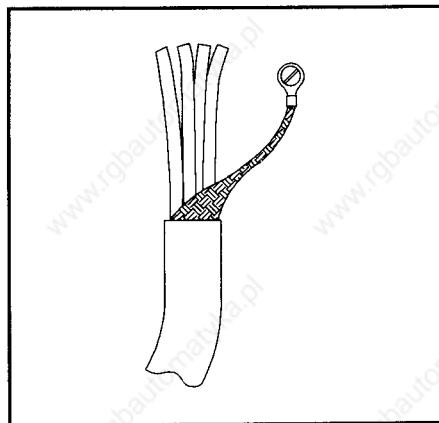

Correct

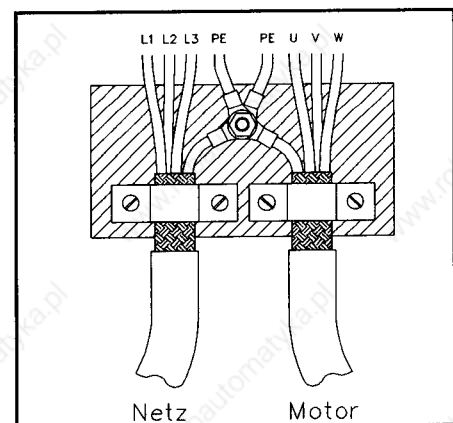

Never only twist the shield and fix it with a screw or a strap, the shield needs to be fixed large surfaced.

The shield always needs to be fixed next to the device at the central earthing point.

Central earthing point: All shields and earthing wires are connected on an uninsulated metal plate next to the device, large surfaced and well conducted.

Connectors control unit X1,X2,(X7)

X1

1	+10V max. 3mA
2	Set point 1 max. +10V
3	Set point 1 max. 20mA
4	Set point 1 max. -10V
5	Display
6	Analog ground
7	Ground 12V
8	Digital ground
9	Enable
10	ccw counter clockwise
11	cw clockwise
12	Input BE1
13	Input BE2
14	Input BE3
15	+12V max. 20mA

Potential conditions at X1
FBS 2008/B - FDS 2024/B

X1

1	+10V max. 3mA
2	Set point max. 10V
3	Set point max. 20mA
4	Analog ground
5	Display
6	Analog ground
7	Shield
8	Digital ground
9	Enable
10	ccw Counter clockwise
11	cw clockwise
12	Input BE1
13	Input BE2
14	Input BE3
15	+12V max. 40mA

Potential conditions at X1
FDS 1040/B - FDS 1085/B

X1

1	+10V max. 3mA
2	Set point max. 10V
3	Set point max. 20mA
4	Analog ground
5	Display
6	Analog ground
7	Ground 24V
8	Digital ground
9	Enable
10	ccw Counter clockwise
11	cw clockwise
12	Input BE1
13	Input BE2
14	Input BE3
15	+24V max. 80mA

Potential conditions at X1
FDS 1110 (/B) - FDS 1200 (/B)

Shielding

The shielding of control cables for the FDS 1110(/B)- FDS 1200(/B) and FBS 2008/B- FDS 2024/B is to be connected at the shielding clamp on the FDS. At devices FDS 1030/B - FDS 1085/B the shielding of the control cables is to be connected to terminal X1.7

Reference potential

The in- and outputs of terminal block X1 have two separated reference potentials. The analog in- and output signals at terminal block X1.2...X1.5 and also the power supply for a set-point adjuster at terminal block X1.1 refer to the Analog ground (X1.6). The digital inputs at terminal block X1.9...X1.14 refer to the Digital ground at terminal block (X1.8). The potential separation of analog and digital control signals provides two advantages.

1. The analog set-point signal and the digital control signals may come from different devices without having to connect their ground potential. (Avoiding of ground loops)
2. The separation of the analog set-point input from the digital control unit provides a high-grade difference input for the set-point signal. Common-mode voltage between digital ground and set-point input are suppressed.

Differences

The function of the terminal blocks X1.7 and X1.15 is different at the series FBS 2008 - FDS 2024, FDS 1030 - FDS 1085 and FDS 1110 - FDS 1200.

FBS 2008/B - FDS 2024/B

Series FBS 2008/B - FDS 2024/B:

- The terminal blocks X1.7 and X1.15 deliver a supply voltage (+12V,20mA) for an external wiring of the control inputs. The supply voltage refers to analog ground and is potential separated against digital ground.
- To use the supply voltage X1.15 for controlling the digital inputs, the reference potential Digital ground (X1.8) has to be connected with ground of the 12V supply voltage, done by connecting the terminal blocks X1.7 and X1.8.

FDS 1030/B - FDS 1085/B

Series FDS 1030/B - FDS 1085/B:

- Terminal block X1.7 has got ground potential (PE). The shielding of a control cable can be fixed here.
- Terminal block X1.15 delivers a supply voltage (+12V,40mA) for external control input wiring. The supply voltage refers to Analog ground.
- To use the supply voltage X1.15 for controlling the digital inputs, Digital- (X1.8) and Analog ground (X1.6) have to be connected. Then the digital inputs and the analog in- and outputs have the same reference potential.

FDS 1110(/B) - FDS 1200(/B)

Series FDS 1110 (/B) - FDS 1200 (/B)

- The terminal blocks X1.7 and X1.15 deliver a supply voltage (+24V,80mA) for an external wiring of the control inputs. The supply voltage is potential separated of the Analog- and Digital ground.
- To use the supply voltage X1.15 for controlling the digital inputs, the reference potential Digital ground (X1.8) has to be connected with ground of the 24V supply voltage, done by connecting the terminal blocks X1.7 and X1.8.

Set-point adjustment

There are four different methods to adjust an external set-point "ref.-val.". The possibilities are shown in the following connection plans with limitation values. The type of set-point adjustment needs to be parameterized in "source ref.value" of the group "setting ref. val".

In the basic adjustment the device is configured in that way, that with the binary inputs BE1 and BE2 (used for selecting a fix ref.-value) left unconnected, the analog set-point is activated. When in basic adjustment high-level is applied to BE1 and/or BE2, the corresponding fix ref.-value is activated. If BE1 and BE2 should be used for selecting fix ref.-values and ramps, refer to the corresponding chapter of the Installation an start-up instructions.

See:

- Groups, Parameter, Values setting ref.val. page 24
- Set-point adjustment page 29
- fix ref.-values page 31
- ramp generator page 31

Set-point adjustment with potentiometer

FBS 2008/B - FDS 2024/B

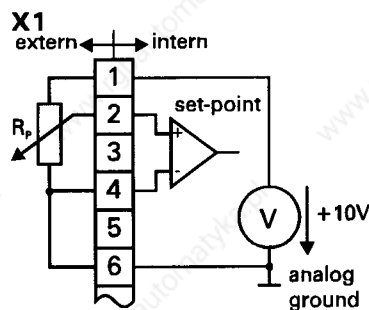

FDS 1030/B - FDS 1200(B)

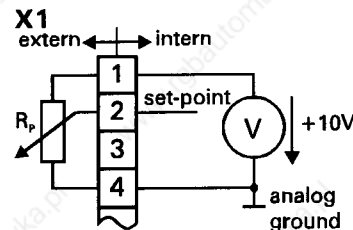

Nominal resistance of potentiometer R_p : min. 4.7k Ω ; max. 20.0k Ω

External voltage set-point

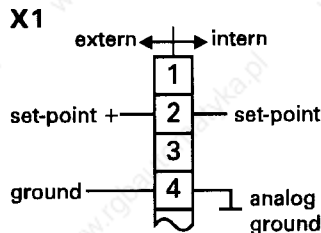

b.) External voltage set-point Input voltage range:

- unipolar: 0...+10V
- bipolar: -10V...+10V

Input resistance: 20.0KOhm

External current set-point

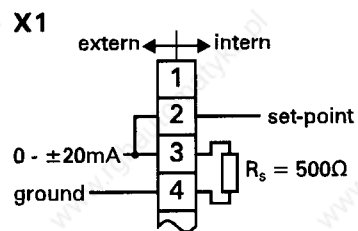

c.) External current set-point Input current range: 0...+/-20mA

The terminal blocks X1.2 and X1.3 need to be connected.

By adjusting the set-point curve (see page 28) the characteristic of the set-point input can be shifted in a wide range. Therefore it is possible to adjust the interface to 4...20mA.

External frequency set-point

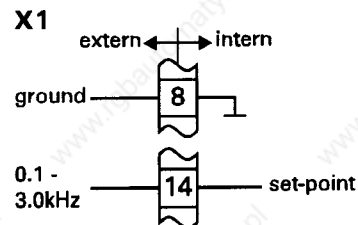

d.) External frequency set-point

The binary input (BE3) is delivered with a square wave signal, the set-point refers to the frequency.

Input frequency: min. 0.01 KHz
max. 3.0 KHz

Input Level	min.	max.
L-Level	-10V	+8V
H-Level	+12V	+32V

Binary inputs

The binary inputs in general are used to control the device. The inputs can be parameterized for different functions. The input functions and the definite function course of the drive are described in the chapters page 19 to 37 and Drive Working Conditions.

The drive of the binary inputs ensues either by an external control with included control voltage or by a switch or relay using the supply voltage of the FDS at X1.15 as a control voltage. In the first case terminal block X1.8 is used as reference potential for the binary inputs. The second possibility is to wire the drive contacts according to the figures shown beneath.

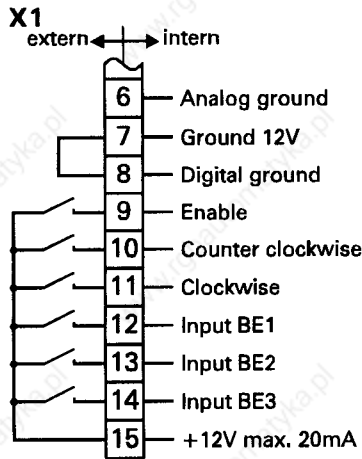

FBS 2008/B - FDS 2024/B

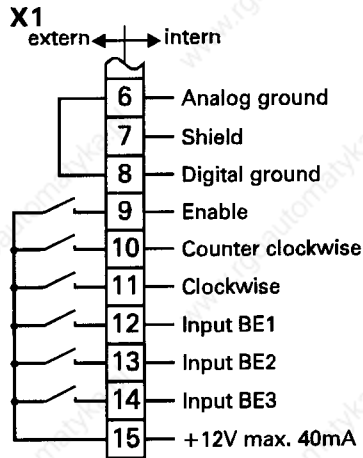

FDS 1030/B - FDS 1085/B

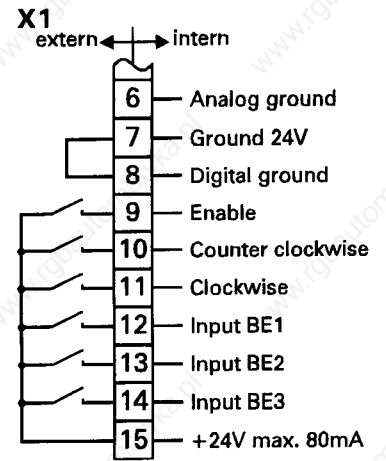

FDS 1110 (/B) - FDS 1200 (/B)

Use of the internal supply voltage at X1.15 for the drive by relay or switch.

See:

Electrical Installation
Connectors control unit page 13

Enable
Counter clockwise ccw
Lockwise cw

The binary inputs "enable", counter clockwise "ccw" and clockwise "cw" control next to the set-point adjustment also the fundamental functions like Enable of power circuit, quick stop and sense of rotation.

See:

Drive Working Condition Page 18/19
Machine Data
Sense of rotation Page 27

BE1 and BE2

The binary inputs BE1 and BE2 can be used for two alternative functions. The basic logic function is the binary set-point adjustment. By combining the inputs BE1 and BE2 a set-point can be chosen out of four fixed set-points (FRV1 - FRV4). The fixed set-points are adjustable with the menu at the FDS.

The alternative is to use the inputs as a motor potentiometer.

BE3

The binary input BE3 can be used for four alternative functions:

1. Additional enable-input
2. Set-point adjustment with frequency input
3. n-feedback for speed control
4. Parameter set selection

See:

Man-Machine-Communication
Parameter Set Selection Page 22
Customer Interface (Cntrl.-Interface)
Binary Input BE3 Page 32

Analog output

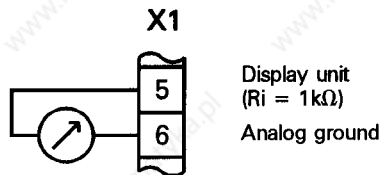

The analog output (terminal X1.5/6) is a voltage output for external display units. Analog ground is the common reference potential of the analog output as well as the set-point input. The output can be adjusted to the special data of a display unit by changing the parameters offset and scaling in the FDS menu. One of the following four device values can be indicated.

- Speed
- Motor voltage
- Effective power
- Motor current

See:

Customer Interface (Cntrl.-Interface)
Analog output page 33

Connection motor temperature probe

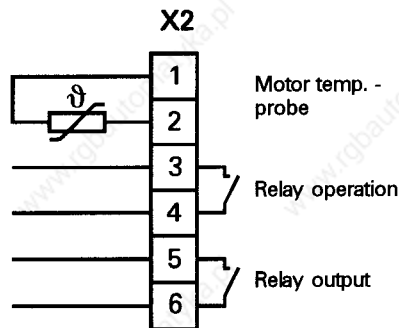

The FDS frequency inverter contains a release unit for motor over temperature protection (TMS-tripping device). The tripping device is built for the use of up to six PTC-resistors (1-2 motors). If the PTC-resistor is connected to the terminal blocks X2.1 and X2.2 the FDS frequency inverter supervises the motor temperature. A time adjustable warning appears on the display, when motor over temperature is detected. When crossing the warning time the motor shuts down with indicating the fault "motor overtemp"

When running a motor without PTC-resistor or the resistor is not in use the terminal blocks X2.1 and X2.2 need to be connected. The input can also be used as a lock. The special behaviour of the adjustable warning time has to be kept in mind.

Attention:

The wiring of the motor-lead and the lead of the motor temperature probe in one common cable is not allowed!

See:

Motor Data
Motor overtemperature page 27
Commissioning page 17
Design Indications
Overload capacity of the motor page 7

relay "operation" and relay output

To reach a universal utilization of the relays, the relay-contacts have no protection circuits. When connecting a resistive/inductive or resistive/capacitive load the relay contacts must be protected by a corresponding protection circuit.

To guarantee safe operation of the relay-contacts do not exceed the minimal and maximal contact-currents of the relays (see technical data page 2, 3).

Relay "Operation"

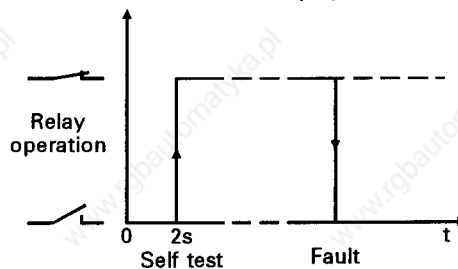

Relay "Operation" indicates readiness of the FDS frequency inverter when activated. The occurrence of a fault deactivates the relays. After connecting the FDS frequency inverter to the mains a self test of the FDS is automatically started. While testing the relay "Operation" is deactivated. Without fault conditions the relay is activated after the self test.

24V-Input (only FDS 1110(B) - FDS 1200(B))

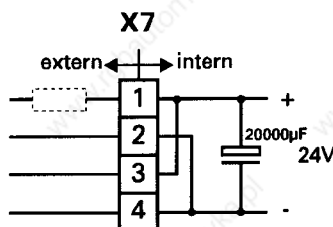

The FDS frequency inverters of the series FDS 1110 - 1200 come with an external 24V input. With that option the control logic is independent from the FDS internal power circuit. The input is designed for a steady connection of a 24V-supply. If the 24V-supply has to be switched, attention must be paid to the internal circuit. The supply then is switched directly on a 20000µF-capacitor. There is no power-up current limitation (contacts of the switching relay may be damaged). If needed a current-limitation-resistor must be added.



Commissioning

The following regulations should be seen as a checklist for the first commissioning of the drive, which should be done without a remote control system. A system with coupled drives should be commissioned by commissioning each drive itself.

At the first commissioning the FDS frequency inverter should be parameterized. The changes listed in the check list will not be stored with the Action "save values". The changes are only important for the first commissioning. After disconnecting the mains the old parameters will be available with the next power restore.

Preparation

- Check of motor winding
Motor winding connected as designed?
FDS frequency inverter adjusted to the motor winding and rating plate?
- Check of main supply voltage
Main supply voltage and voltage in technical data description (page 2) are the same?
- Check of connections
Pin and socket connector are fixed correctly?
All screw connections are tightened?



Intermittent contacts cause spikes at motor and FDS frequency inverter. To avoid failures and demolition caused by voltage spikes all connections between motor and FDS frequency inverter need to be tightened.

First power connection

- Enable off
The maximum voltage at input "Enable" (X1.9) is 8V.
- Set-point= 0
The set-point should have 0V.
- Check of drive mechanic
Is the drive blocked?
Brake is correctly connected?
- Connecting the mains
Display indicates for 2 seconds



- Check of intermediate circuit voltage
see Display Values, intermediate circuit voltage (internal voltage)
FBS 2008/B, FBS 2013/B: The intermediate circuit voltage is between 170V and 390V?
FDS 2014/B, FDS 2024/B: The intermediate circuit voltage is between 280V and 670V?
FDS 1030/B - FDS 2013/B: The intermediate circuit voltage is between 460V and 620V?
FDS 1110/B) - FDS 1200/B): The intermediate circuit voltage is between 510V and 750V?
If the value is out of this range check main supply connection and voltage.
- Check signals at the customer interface
Correspondence between definite signals at the customer interface and indication at the display is provided?
(check both signal levels at each used input)



Caution when testing input "enable" ! H-level at input "enable" activates the power circuit of the FDS frequency inverter. An additional choice of rotation sense and set-point will start the drive.

H-level at the inputs clockwise "cw" and counter clockwise "ccw" when testing the "enable" will solve this problem. The rotation sense is invalid, the power circuit activated but the drive will not start.

Sense of rotation

- Check correspondence of motor rotation sense and chosen rotation sense
Use "Key control" as operation input (see Operation, Operation input). Choose rotation sense by using the rotation sense inputs. Adjust the speed to a low figure by using the keys. Change wiring U,V,W at terminal block X11 when incorrect rotation sense is indicated.

Nominal operation

- Check drive behaviour at nominal speed
Increase the speed slowly up to the nominal speed by using the keys. Check motor current at the display (see DisplayValues, Device Values, Motor Current).
(Motor current at no-load operation approx. 30%-60% of nominal motor current)
(Loaded motor current maximum up to nominal motor current)
- Enable off
Dead motor flow out
- Disconnect the mains

Drive working conditions

The drive while running operates in different conditions. After activating the drive it passes through definite conditions shown in a diagram page 18. These conditions are characterized by different features.

Application

The condition diagram is a design and commissioning aid for the drive control. The drive working conduction in dependence of control signals, adjustments and external events can be monitored. Control failures are easily localized with the diagram and displayed values.

Description of a drive working condition

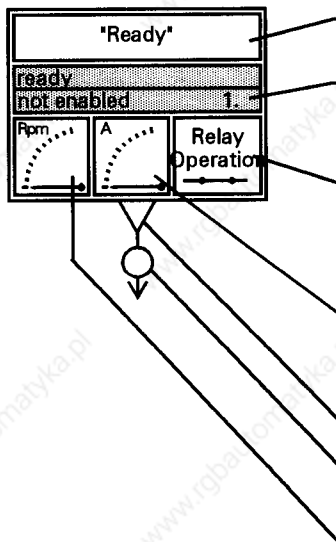

The first array describes the drive working condition.

The second array shows the corresponding display value of the drive working condition. When indicating current operational data they come with a row of "X". Messages or warnings are indicated at every time independent of the drive working condition. At that stage the display deviates.

The condition of the relay "Operation" is shown.



operative



not operative

The ammeter is a synonym for the motor current.

It is distinguished between three possibilities:

1. Motor current = 0/Ammeter indicates 0
2. Motor current is controlled at retaining current/Ammeter indicates IH
3. Motor current at nominal operation/Ammeter indicates 60% of the end scale value

The triangle with related text show conditions for leaving the state by using this way.

A condition providing progress conditions, the circles with related text indicate under which boundary conditions which progress condition is taken.

The shown speed measuring apparatus provides three cases:

1. Drive standstill/measuring apparatus indicates 0
2. Drive runs at nominal speed/measuring apparatus 60% of the end scale value
3. Drive brakes at the quick-stop-ramp/pointer at position 0

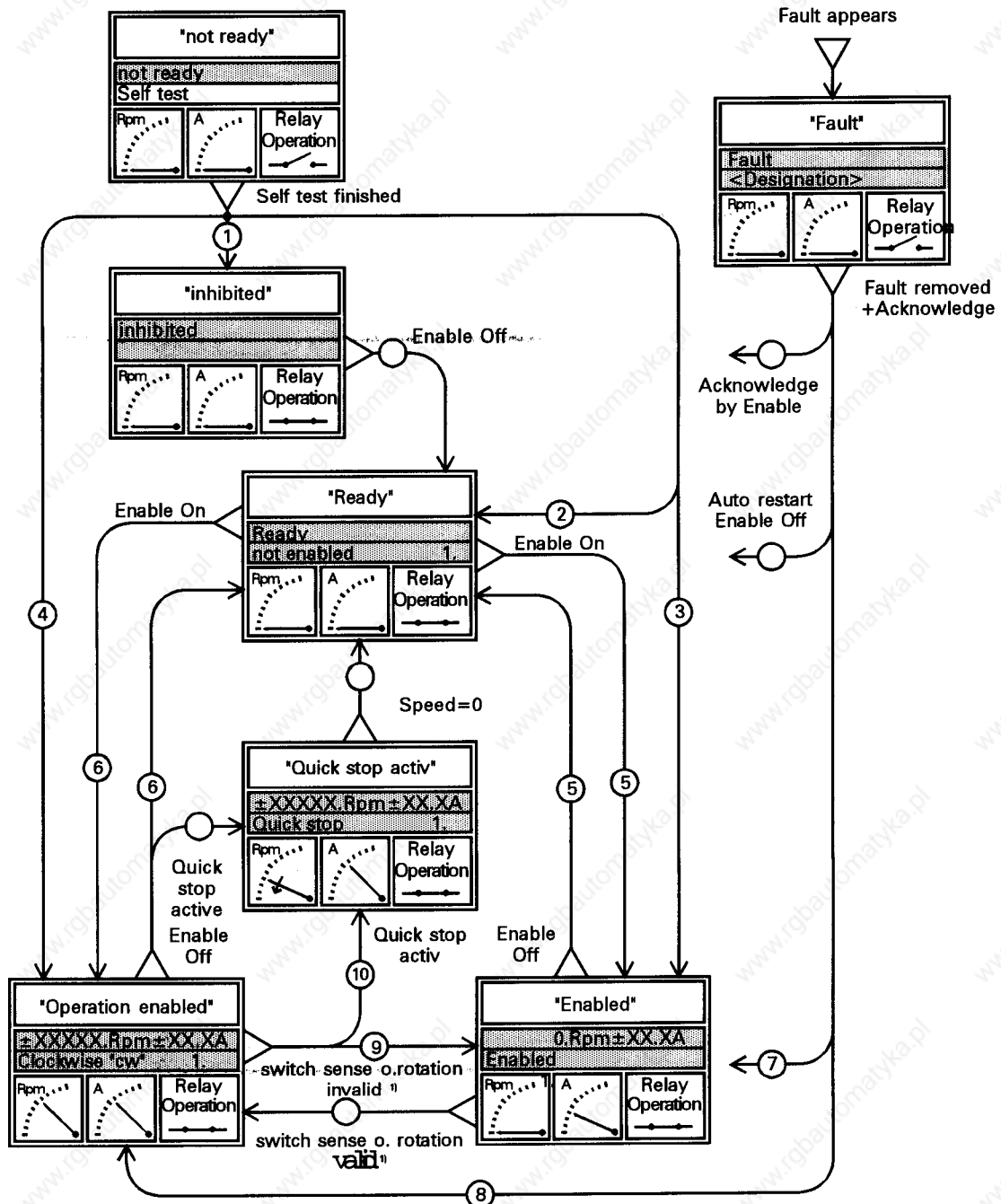

- ① Charge relay not o.k.
or
enable is on
and
auto start is inactive
- ② Charge relay is o.k.
and
auto start is inactive
and
enable is off
- ③ Charge relay is o.k.
and
auto start is active
and
enable is on
and
sense of rotation is invalid
- ④ Charge relay is o.k.
and
auto start is active
and
enable is on
and
sense of rotation is valid
- ⑤ sense of rotation is invalid

- ⑥ Sense of rotation is valid
- ⑦ Fault removed
and
auto restart active
and
enable is on
and
sense of rotation is invalid
- ⑧ Fault removed
and
auto restart active
and
enable is on
and
sense of rotation is valid
- ⑨ speed = 0
- ⑩ Quick stop active
and
clockwise "cw" is off
and
counter clockwise "ccw" is off

1)

Sense of rotation	Input cw	Input ccw
invalid	OFF	OFF
clockwise	ON	OFF
counter clockwise	OFF	ON
invalid	ON	ON

Mimic Diagram For Adjustment And Display

FBS / FDS

STÖBER ANTRIEBSTECHNIK

STANDARDDISPLAY:

ready
not enabled P.
xxxxx.rpm yy.yA
OPERATIONDISPLAY

P - Display of active parameter set

Decelerating	P.	Operation condition
Accelerating	P.	at device condition
Clockwise	P.	"operation"
Counterclockwise	P.	
Speedlimit	P.	
Currentlimit	P.	

Accel l-regul.	P.	Messages (flashing)
Decel U-regul.	P.	at device condition
Boost l-regul.	P.	"operation"
Low voltage	P.	
n-reduction	P.	

Enabled	P.	device condition "enabled"

Quick stop	P.	device condition "Quick stop activ"

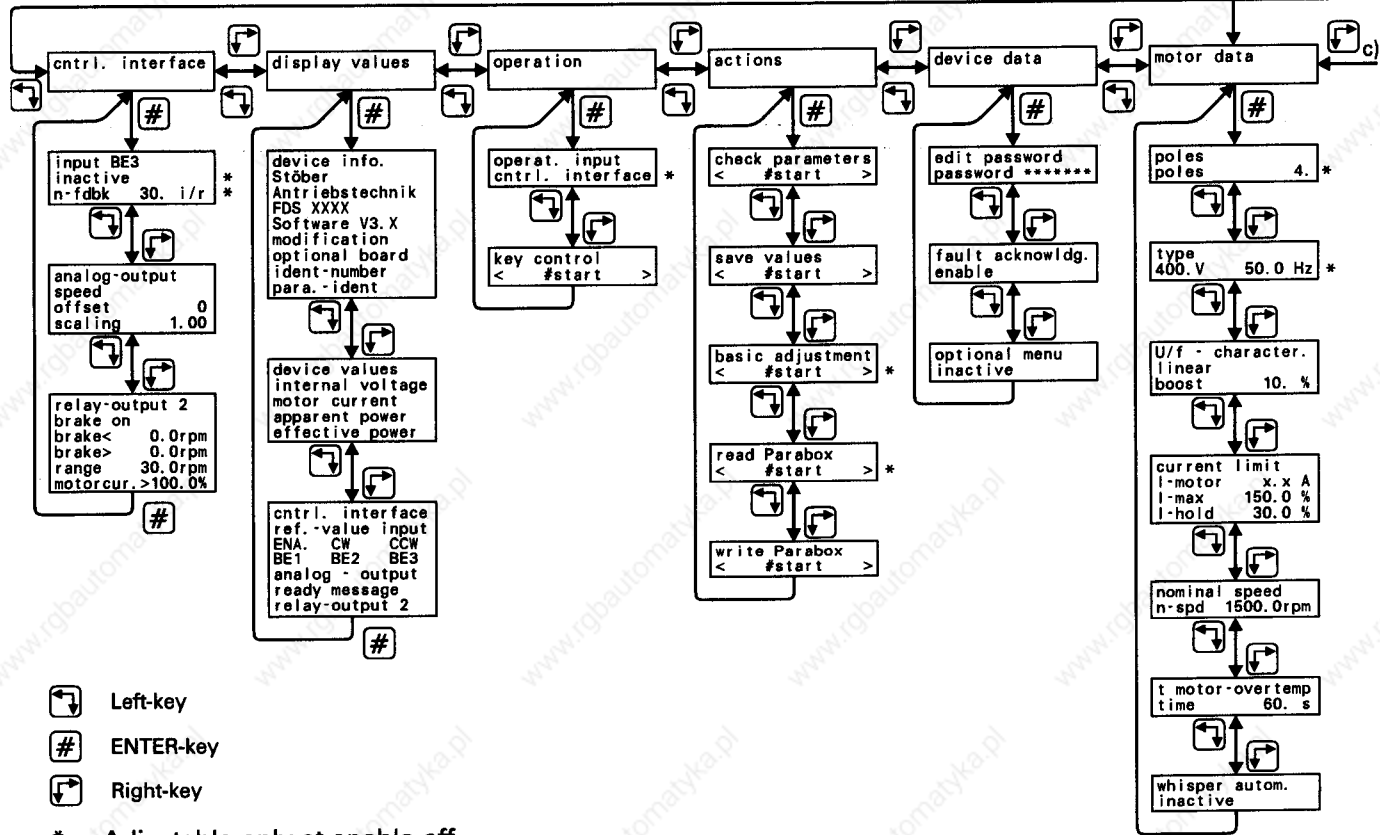
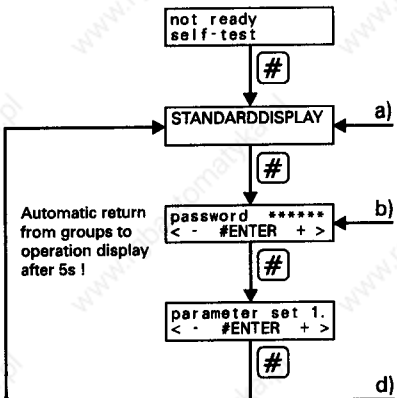

- Left-key
- ENTER-key
- Right-key

* = Adjustable only at enable off

Caution: Save new values before disconnecting the mains !

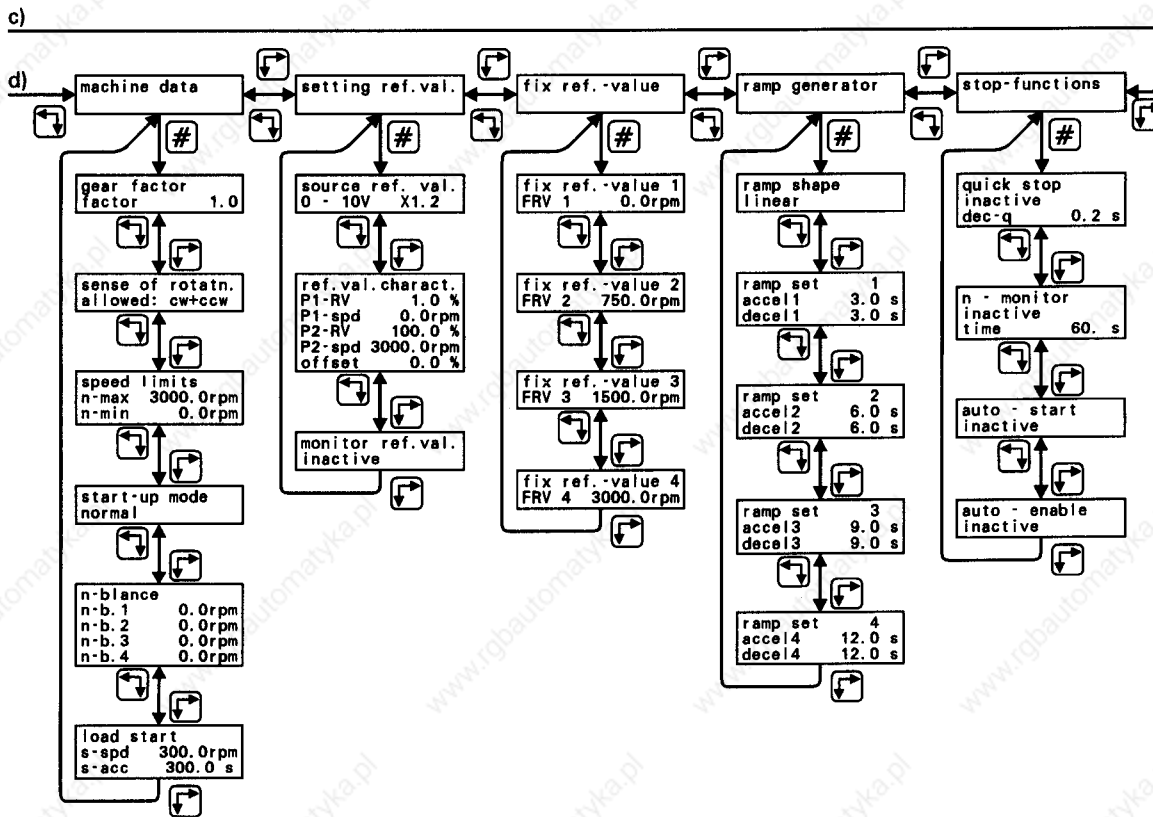
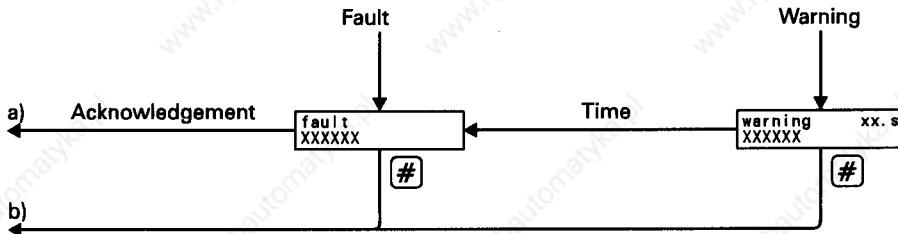



Man-Machine-Communication (MMC)

For the adjustment, operation and control of the device different possibilities are delivered:

1. With FDS frequency inverter keys and display
2. With serial interface (RS 232) and FDS-Tool software

The transmission of data can either be done by using FDS-Tool with an interface cable or by the Stöber-Parabox.

The possibilities are shown in the following sections.

Adjustment and operation by display and keyboard

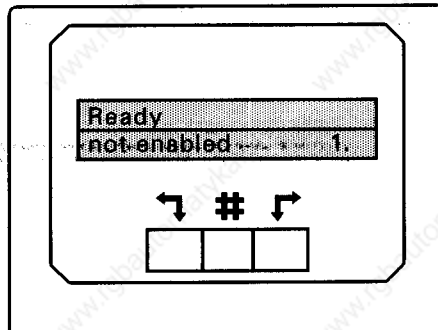

The operation unit at the device consists of an LC-display with 2*16 digits and three keys. With the operation unit the parameters can be adjusted and also the drive conditions, messages, warnings and faults are indicated.



The parameter adjustment is divided in groups which contain several parameters. A parameter refers to a special device function and can contain several adjustable values or only indication values.

Choosing a parameter set for adjustment

Selecting of parameter sets

The FDS frequency inverter is delivered with a basic adjustment of all values. This basic adjustment can always be restored with the Action "basic adjustment".

The "Mimic Diagram For Adjustment And Display" shows the operational principle of the menu technique.

To start the process of adjusting, changing or indicating of set Values/Choice the Enter-key  is to be pushed to begin at the menu parameter "Password". Enabled personnel only can change data (Values/Choice), others have only the allowance to view the data. With no password stored the parameter password can be left out by pressing . With the next step the valid parameter set can be chosen by confirming with the  key. Without an optional board I/O-extension parameter set 1 and 2 are available. The choice made here only refers to the adjustment of parameters of the chosen parameter set. The choice of the active parameter set used in operation is done by the binary input BE3 if the function is "para-set select". With included optional board I/O-extension four different parameter sets can be configured. This enables the use of four different motors with one FDS frequency inverter.

See:

Customer Interface (Cntrl. Interface)
BE3 page 32

The Values/Choice can be chosen and changed with the left  and right  key. The change can be confirmed by the  key (see Programming Example Page 39).

Without operating a key when working in a group or password the program will automatically return to the standard display after 5 seconds. From Values/Choice there is no automatically return to the standard display.

Caution: When disconnecting the FDS frequency inverter from the main supply a time of minimum 0.5 s is to be waited before the next restart. A shut down will provide a loss of changed values if not saved with "save values".

Caution: For safety reasons some parameters can only be changed at condition "enable off". When enabling during a change of parameters the enable signal will have response after leaving the menu.

Groups, Parameter, Values page 24
Mimic Diagram For Adjustment And Display pages 20/21



See:

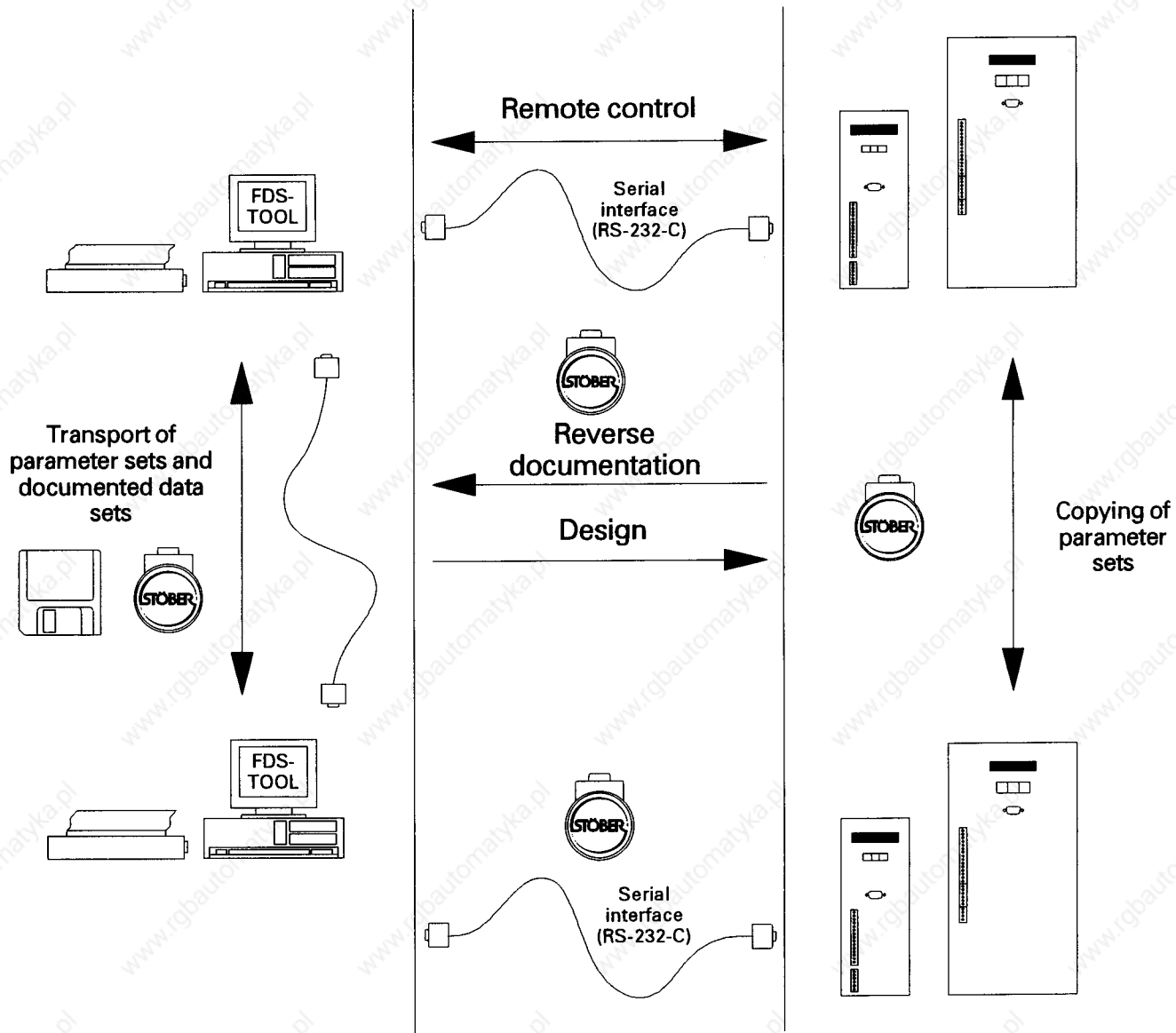

FDS-TOOL

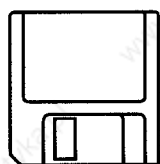

Parabox



FDS-Tool is a support program for the series FDS 1040/B - FDS 1200(B). The program can be ordered with the Id.-No. 67.788 (5.25"-disks) and Id.-No. 67.789 (3.5"-disks). The connection to the FDS frequency inverter is realized by means of the serial interface (RS-232). The following functions are available with the comfortable operation surface:

Design:

Preparing, documentation and filing of parameter sets. The correct sets of parameter are transmitted to the FDS frequency inverter by the serial interface or by means of the parabox.

Reverse documentation:

Diagnosis and documentation of parameter sets resp. occurred failures.

File management:

Management of the parameter set files, printing, write parabox, transmission of parameter set to the FDS frequency inverter.

The parabox is for the use of wireless FDS parameter set transmission.

It is adjustable either at the serial interface of PC or FDS frequency inverter. Parameter sets can be transmitted from PC to the FDS and from the FDS to PC, also an exchange between FDS or PC is possible. To read and write upon the parabox with a PC the software FDS-Tool is necessary.



Groups, Parameter, Values

The following table "Groups, Parameter, Values" explains the parameter that can be changed by the customer.

Parameter/Actions that are marked with a * are only changeable at stage "enable off". The enable stays inactiv during parameterizing. If the enable is activ after adjusting these parameters, the drive will start automatically.

Group	Parameter / Action	Value/ Choice (Basic adjustment underlined)	
Motor data	* poles	2, <u>4</u> , 6 ... 16	
	* type	400V/ 10.0 ... <u>50.0</u> ... 400.0 Hz	
	U/f-character.	<u>linear</u> /square / boost 0 ... <u>10</u> (<u>10</u>) ¹ ... 100 %	
	current limit	I-motor: FDS 1040 0 ... <u>2.6</u> ... 5.5 A FDS 1070 0 ... <u>4.8</u> ... 10.0 A FDS 1085 0 ... <u>5.8</u> ... 12.0 A FDS 1110 0 ... <u>7.8</u> ... 16.0 A FDS 1150 0 ... <u>10.7</u> ... 22.0 A FDS 1200 0 ... <u>15.6</u> ... 32.0 A	
		I-max 100 ... <u>150</u> ... 200 % I-hold 0 ... <u>30</u> (<u>30.6</u>) ¹ ... 100%	
	nominal speed	n-spd 0... <u>1500</u> ... 4500 (<u>6000</u>) ¹ rpm	
	motor overtemp.	time 5... <u>60</u> ...120 s	
	whisper autom.	<u>inactive</u> , active	
	machine data	gear factor	i = 0.1 ... <u>1.0</u> ... 999.9
		sense of rotatn.	allowed clockwise/ counter clockwise/ <u>cw+ccw</u>
speed limits		n-max 0... <u>3000</u> ...4500 (<u>6000</u>) ¹ rpm / n-min <u>0</u> ... 4500 (<u>6000</u>) ¹ rpm	
* start-upmode		<u>normal</u> , load start, cycle character	
n-blance 1-4 load start		respective <u>0</u> ... 4500 (<u>6000</u>) ¹ rpm s-spd 0 ... <u>300</u> ... 4500 (<u>6000</u>) ¹ rpm, s-acc 0.1 ... <u>300</u> s	
setting	*source ref.val. motor potentiometer	<u>0...±10V</u> , 0...±20mA, 10Hz...3.0kHz, <u>ref.val</u>	
	*ref.val.charact.	P1-RV 0 ... <u>1%</u> ... P2-RV P1-spd <u>0</u> ... 4500 rpm P2-RV P1-RV ... <u>100%</u> P2-spd 0 ... <u>3000</u> ... 4500 (<u>6000</u>) ¹ rpm Offset -10.0 ... <u>0</u> ... +10.0 %	
	monitor ref.val.	<u>inactive</u> , active	
fix ref.value	fix ref.-value 1	FRV1 <u>0</u> ... n-max rpm	
	fix ref.-value 2	FRV2 0 ... <u>750</u> ... n-max rpm	
	fix ref.-value 3	FRV3 0 ... <u>1500</u> ... n-max rpm	
	fix ref.-value 4	FRV4 0 ... <u>3000</u> ... n-max rpm	
ramp generator	ramp shape	<u>linear</u> , smoothed	
	ramp set 1	accel1 0.1 ... <u>3</u> ... 300 s/150 Hz; decel1 0.1 ... <u>3</u> ... 300 s/150Hz;	
	ramp set 2	accel2 0.1 ... <u>6</u> ... 300 s/150 Hz; decel2 0.1 ... <u>6</u> ... 300 s/150Hz;	
	ramp set 3	accel3 0.1 ... <u>9</u> ... 300 s/150 Hz; decel3 0.1 ... <u>9</u> ... 300 s/150Hz;	
	ramp set 4	accel4 0.1 ... <u>12</u> ... 300 s/150 Hz; decel4 0.1 ... <u>12</u> ... 300 s/150Hz;	
	stop-functions	quick stop	<u>inactive</u> , active / decel-s 0.1 ... <u>0.2</u> ... 300.0 s
		n-monitor	<u>inactive</u> , active/ time 0... <u>60</u> ...255 s
		auto-start	<u>inactive</u> , active
auto-enable		<u>inactive</u> , active	

¹ For FBS 2008/B - FDS 2024/B



Groups, Parameter, Values

cntrl.-
interface

* input BE 3

n-feedback, add.enable, inactive,
para.- set select /
n-fdbk 1...30...255 I/U

analog-output

speed, motor voltage, effective power,
motor current / offset -13 ... 0 ... 13 /
scaling 0.01 ... 1.00 ... 10.00

relay-output 2

brake on, ref.-val.reached,
motorcur.reached, warning /
brake < 0 ... 300rpm /
brake > 0 ... 300 rpm /
range0 ... 30 ...749rpm,
l-motor > 0 ... 100 ... 150%

display values

device info.

Stöber Antriebstechnik, FDS XXXX/
Software V3.X, modification,
optional board, ident-number,para.-ident
internal voltage, motor current, apparent
power, effective power
ref.-value input, ENA/CW/CCW,
BE1/BE2/BE3, analog-output,
ready message, relay-output 2

device values

cntrl.-interface

operation

* operat. input

cntrl.-interface, Service-PC,
optional board, key control
key control < - #STOP + >

actions

check parameters
save values
* basic adjustment
* read parabox
write parabox

param. right, wrong
save values
basic adjustment
read parabox
write parabox

device
data

edit password
fault acknowldg.

password / password 000000 ... 999999
power-reset, enable, auto-receipt,
#enter
inactive

optional menu

Significance of rotational speed

The speed in rpm refers to the power take-off from the gear. Therefore the number of motor poles and the gear factor are included in the rotational speed at power take-off from the gear. All specified speeds in the table shown above presume a number of poles of 4 and a gear factor of 1. A deviation between drive data and FDS values causes the necessity of multiplying the values with a correction coefficient.

$$n_x = n \cdot \frac{4}{p \cdot i}$$

n_x = converted speed
 n = specified speed
 p = number of motor poles
 i = gear factor
(1 without the use of a gear)

Example:
Basic adjustment of n-max

$$n_x = 3000 \text{ Upm} \cdot \frac{4}{2 \cdot 10} = 600 \text{ Upm}$$

p = 2 (2-pole motor)
(nominal speed approx. 3000 rpm)
 i = 10
(gear with 10-times step down gear)

A 2 pole motor and a gear with gear factor $i=10$ needs a basic adjustment $n\text{-max}=600$ rpm.

See:

Motor Data
Number of poles page 26
Machine Data
Gear factor page 27

Motor Data

Number of poles

The technical motor data are relevant. The motor data are the first data to be inputted.

Nominal point (type)

The number of poles is marked on the rating plate of the motor. Two poles equal a pair of poles. Number of poles > 16 (pair of poles > 8) is not possible. For a correct speed calculation the number of poles is needed. When changing the number of poles after the input of speed values, the speed values will be automatically adjusted.

U/f-characteristic

The nominal point at the U/f-characteristic shows, at which frequency the motor voltage achieves 400V~ (Adjustment of voltage raise with a frequency change). A motor with different winding demands a new calculation of the nominal point.

The U/f-characteristic needs to be adjusted dependent on the motor data for star or delta connection.

The maximum output voltage of the FDS frequency inverter is 3* 400V. It can be chosen between two characteristics:

a.) Linear characteristic, for all applications.

b.) Square-characteristic, for the use at turbo-machines like pumps and ventilators.

Boost

The boost (voltage increase; 100% boost equals 110V at 0Hz) is adjustable for both characteristics between 0 and 100%. The connection of the motor is to be considered.

Figure:
U/f-characteristic, boost

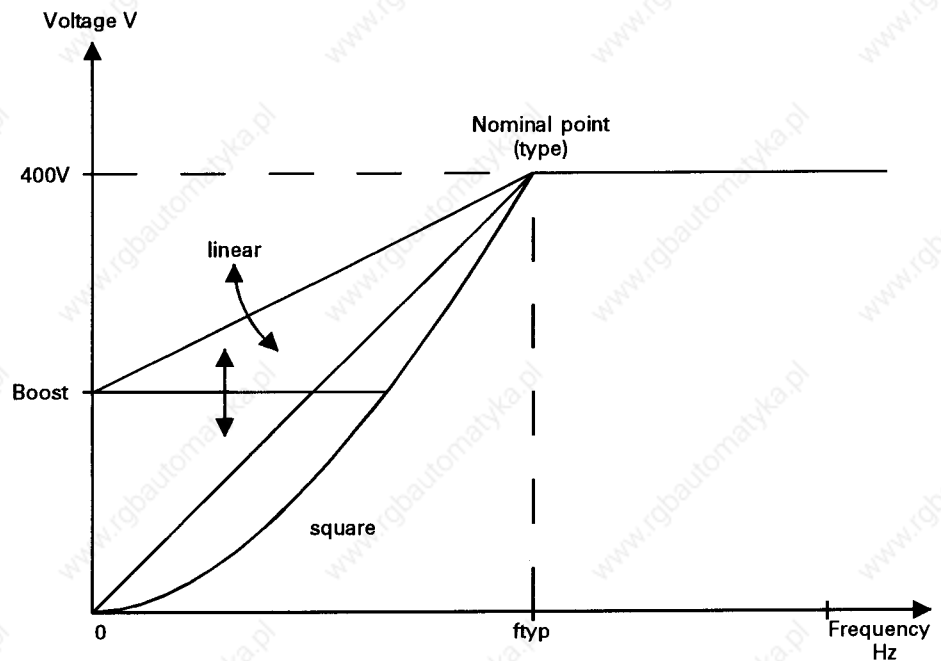

Current limitation
I-max, I-motor

The current limitation works on two adjustable limiting values, I-max and I-motor. I-motor in general is the nominal motor current at continuous operation. I-max is the maximum short time current. The maximal current I-max can be adjusted between 100%-200% of I-motor, the absolute limit however is 150% of the FDS nominal current (see Technical Data Page 2).

Principle of operation

The overload operation time is limited to 30s (current between I-motor and I-max). The time with a motor current higher I-motor is added, the time beneath I-motor is subtracted (minimum time 0). In case of exceeding 30s the overload time range is exceeded. The motor current will be limited by the current controller to I-motor. A time sum of 0s sets the limited value of motor current back up to I-max.

Retaining current

The current limitation is achieved by a reduce of boost and if necessary by a reduce of speed. The activated current limitation will be displayed by the measures "boost I-regul." and "n-reduction".

The Value/Choice "I-hold" describes the current in % of I-motor that is delivered with motor speed 0. The limitation to the retaining current I-hold is done by the current limitation, by limiting the adjusted boost. Therefore the current I-hold will only be achieved with a high boost adjustment. The limitation to I-hold is also displayed by the measure "boost I-regul.".

The values I-max and I-hold are both related to the value of I-motor. During parameterizing the recommended sequence shall be observed, which means first adjusting I-motor and then I-max and I-hold.

At I-motor = 0 the current will not be indicated in the standard display. Besides current controller and limitation are out of order. The short cut disconnection stays activ.



Figure: Current limitation

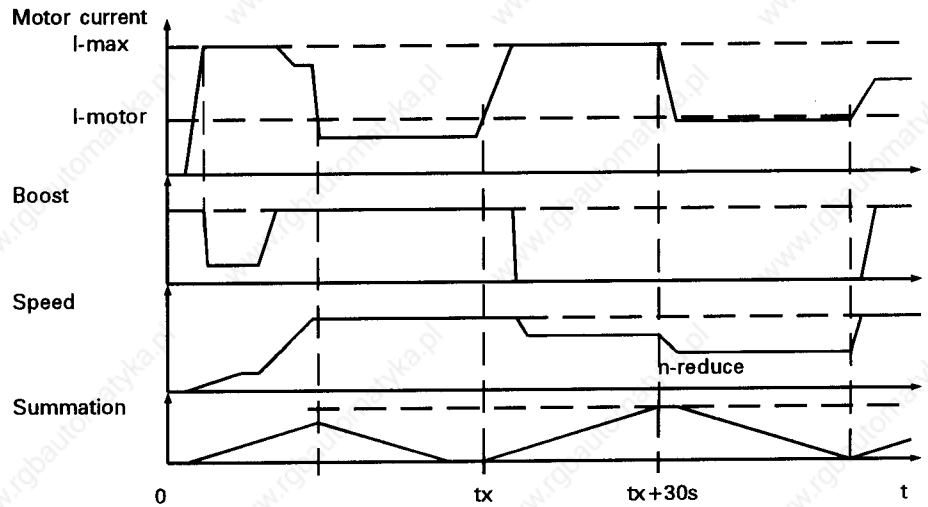

Nominal speed

The nominal speed is shown on the rating plate of the motor or the motor data list. Keep in mind, that the nominal speed refers to the take-off speed of the gear. Only with a gear factor of 1 the take-off speed of the gear is the same as the nominal motor speed.

Motor overtemperature

The FDS frequency inverter displays the warning "motor overtemp." and the fault "motor overtemp.". The time between the first warning and the release of the fault is adjustable from 5s to 120s. During warning stage the motor can be driven, for example to go in a safe position.

Whisper automatic

With active "whisper autom." the noise of the motor will be minimized. The clock frequency will be adjusted in dependence of I-motor.

I-motor / nom. device current Typ	<12.5%	<25%	<37.5%	<50%	<62.5%	<75%	<87.5%	<100%
FBS 2008/B - FDS 2024/B	12kHz	10kHz	8kHz	6kHz	4kHz	4kHz	4kHz	4kHz
FDS 1030/B - FDS 1085/B	10kHz	10kHz	10kHz	10kHz	9kHz	7kHz	5kHz	3kHz
FDS 1110 (V/B) - FDS 1200 (V/B)	9kHz	9kHz	9kHz	9kHz	6kHz	6kHz	3kHz	3kHz



Machine Data
Gear factor

When using shielded motor cable at the devices FDS 1040/B - FDS 1085/B the whisper automatic shall only be activated with installed EMC-pack. Otherwise the maximum stray power will be crossed.

At the group Machine Data the technical drive data need to be input.

The gear factor is the ratio between motor speed and gear take-off speed and can be adjusted in the range of 0.1.....999.9. Without a gear the factor is 1 (basic adjustment).

$i > 1$ gear reduction

$i < 1$ gear increasing

For correct calculation of the speed the gear factor is needed. With MGS-gears the gear factor is included in the type designation (f.e. C302 F 0620 D80L4, gear factor= 62.0). Gear factors of following gears need to be kept in consideration. Changing the gear factor after the input of the speed will cause a adjustment calculation of the speed.

See:

Groups, Parameter, Values

Significance of rotational speed page 25

Sense of rotation

The admitted "sense of rotatn." is to be fixed here. When setting unadmitted sense of rotation at the inputs clockwise "cw" (veer in viewing direction to the motor shaft) or counter clockwise "ccw", the drive will be stopped by the decel function (see figure). With both inputs at the same level the sense of rotation is locked.

In case of active quick stop function a L-level at both sense of rotation inputs will cause a quick stop. Compared to the quick stop release with the enable input, the motor stays under voltage with a H-level at the enable input. This function enables a wire break detection of the rotation sense inputs and stops the drive as fast as possible.

The named sense of rotations are only valid with correct connected motor.



Effect of the sense of rotation inputs

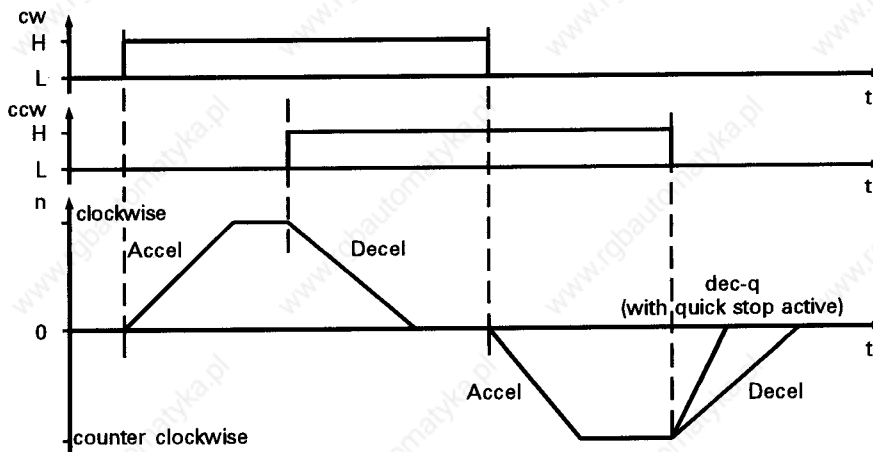

Speed limits

The speed limits "n-max" and "n-min" narrow the allowed speed range. The limits of these parameters are set by the number of poles and the gear factor.

See:

Groups, Parameter, Values
Significance of rotational speed page 25

Start-up mode

Three start-up modes "normal", "load start" and "cycle character" are adjustable. For all characteristics the current limit is 30s I-max and afterwards I-motor (see Motor Data - Current limitation, page 26). To deliver the demanded current the boost has to be adjusted correctly (see Design Indications table page 9).

Normal start

With "normal start" the current is limited to I-hold at speed 0, the drive accelerates with the adjusted ramp.

Load start

The "load start" is used at drives that demand a higher breakaway torque (f.e. to overcome the static friction). Therefore the speed at current limit I-max is to be increased with the ramp "s-acc". From the at "s-spd" adjusted speed the acceleration runs by the normal ramp. At speed 0 the motor current is limited to I-hold.

Cycle character

To achieve an optimum acceleration behaviour at "cycle character" operation the motor is excited with I-motor at speed 0. The drive will be accelerated with the chosen ramp.



Speed blance

Motors without forced air cooling driven at very low speed or speed 0 with high current for a longer period tend to overheat.

The "n-blance" avoids the operation with resonant speed which could cause machine damage. With the "n-blance" parameter 0 the speed blance is deactivated. A parameter unlike 0 causes the motor to run with the fastest ramp through the blanced speed range. The speed range is equivalent to a frequency range of +0.4Hz. The speed blance 1-4 can also be used in a row, that provides a wider frequency range.

The blanced speed range that refers to the frequency range of +0.4Hz is dependent on the number of motor poles and the gear factor. It is calculated with the following formula.

Example:

$$n = 780 \text{rpm} \pm \frac{0.4 \text{Hz} \cdot 60 \text{s} \cdot 2}{p \cdot i} \text{rpm}$$

$$p = 4 \quad i = 1$$

$$n = 780 \text{rpm} \pm 12 \text{rpm}$$

$$= 780 \text{rpm} \pm \frac{48}{p \cdot i} \text{rpm}$$



Set-point adjustment (setting ref.val.)

The FDS frequency inverters deliver several possibilities of set point commands:

- a) 0...+10V
- b) 0...+20mA
- c) FRV 1
- d) FRV 2
- e) FRV 3
- f) FRV 4
- g) 0.1...3kHz
- h) motor potentiometer
- i) key operation
- j) FDS-TOOL
- k) optional board

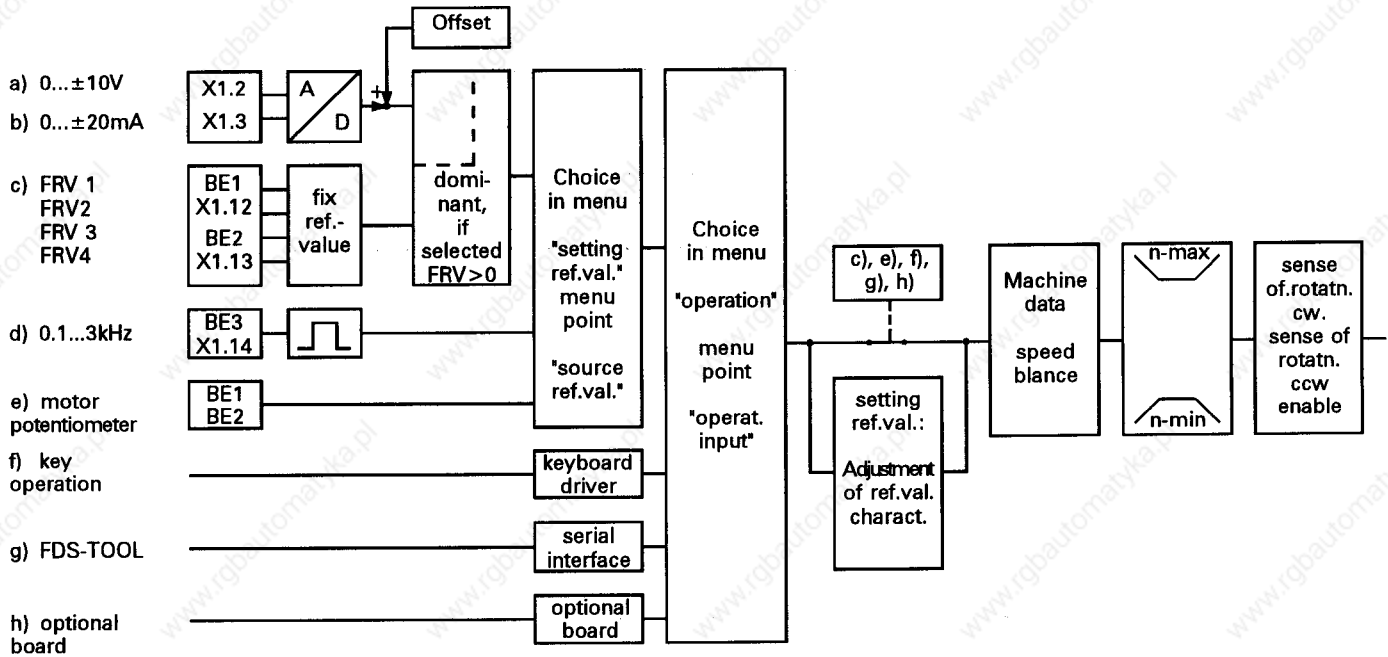

At a,b and d a correspondence between speed and set point can be adjusted by using the set point characteristic ("ref.val.charact."). The input 0.1....3.0KHz is connected to the binary input BE3. If the with BE1 and BE2 chosen "fix ref.-value" is higher 0 rpm, the analog outputs a,b and d are inactive.

Motor potentiometer

Binary inputs		Speed
BE1	BE2	
L-level	L-level	constant
H-level	L-level	higher
L-level	H-level	lower
H-level	H-level	0

With the set point adjustment by motor potentiometer function the binary inputs BE1 and BE2 are used for simulating the motor potentiometer. The effect of these control inputs is shown in the table beneath. The sense of rotation is set by the inputs clockwise "cw" and counter clockwise "ccw". The set-point source ("source ref.val.") changes with the in "ramp set 1" adjusted speed. The set-point is kept after take off of "enable" or "sense of rotatn.", when reversing and after disconnecting the mains (non volatile memory).

Keyboard operation

see Operation, operat. input - key operation page 35

Set-point characteristic

The "ref.val. charact." is fixed by the points P1 and P2. P1 has got the coordinate P1-RV and P1-spd, P2 the coordinate P2-RV and P2-spd. A set-point 0...+10V, 0...+20mA or 0.1...3.0KHz corresponds to a set-point command of 0...100%. At P1-RV the initial set-point and at P1-spd the corresponding initial speed need to be adjusted. The same with the P2-RV tail set-point and the corresponding final speed P2-spd. At set-points beneath P1-RV and higher P2-RV the speed stays constant. Therefore it is possible to adjust every correspondence between set-point and speed in the allowed set-point range. A +5% individual device tolerance is to be taken in consideration when setting the final speed P2-spd. To achieve speed 0 at disconnected set-point, P1-RV need to be higher than 1%.

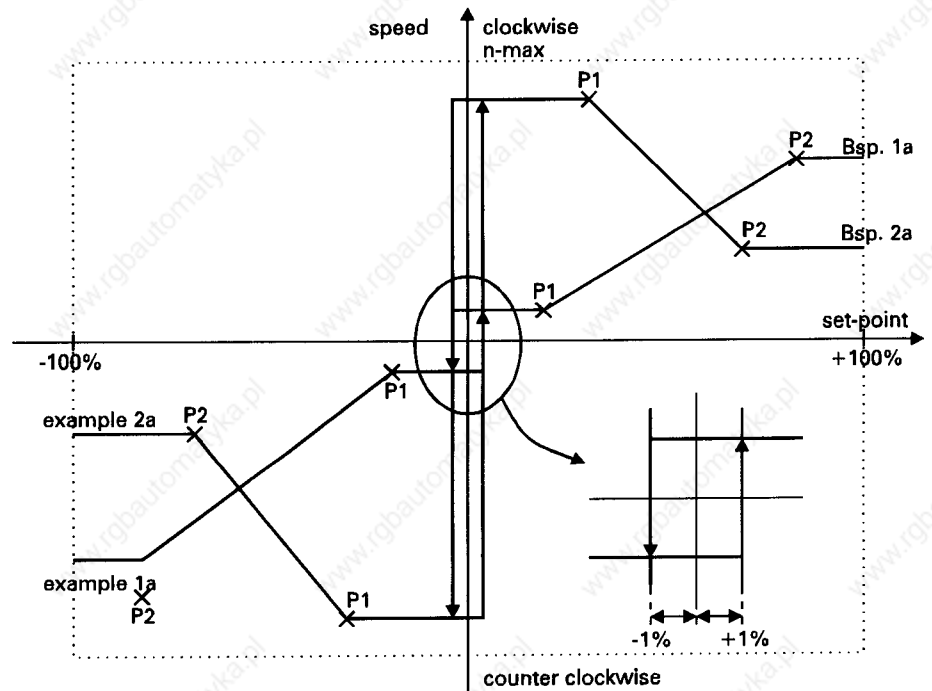
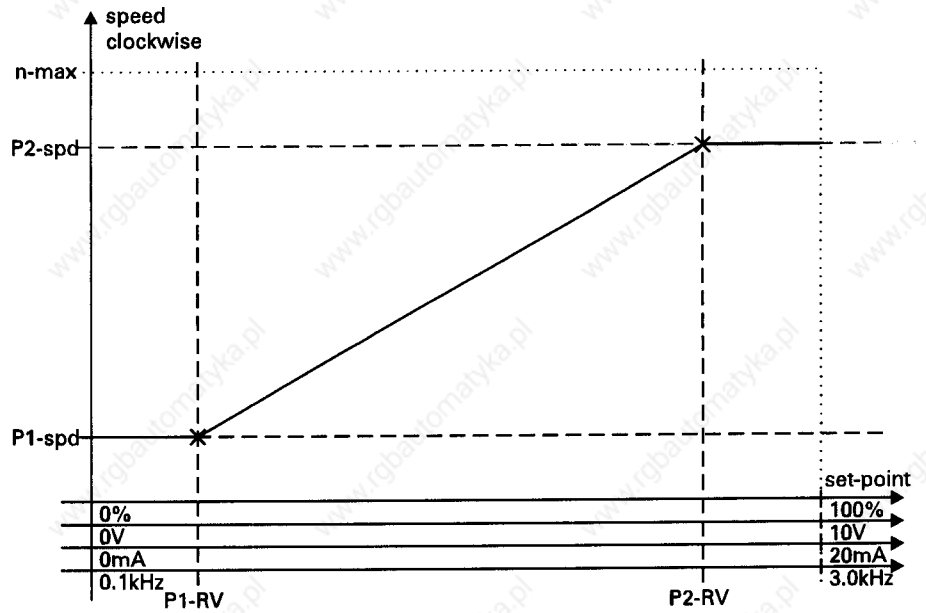

Offset

The Value/Choice "offset" enables the compensation of a voltage at the terminals X1.2, X1.4 resp. X1.2/3, X1.4 at set-point adjustment of 0V/0mA to 0%. The compensation is done by setting the offset to the inverse amount of the displayed amount at "display values-cntrl.interface-ref.-value input". The offset is adjustable in the range of -10% and +10%.

Example:

The displayed offset at "display values-cntrl.interface-ref.-value input" is 2.5%. The offset has to be adjusted to -2.5%.



Adjustment of the set-point characteristic to the maximum speed

External bipolar set-point

Set-point monitor (monitor ref.val.)

set-point $\pm(4 \dots 20\text{mA})$

To ensure that 10V/20mA deliver the adjusted maximum speed the Value/Choice "ref.-value input" in "display values-cntrl.interface" needs to be adjusted. If not 100% is displayed, the set point characteristic is to be adjusted. At "setting ref.val.-ref.val.charact." the "P2-RV" is to be adjusted to the deviated amount and "P2-spd" to the maximum speed.

The FDS also provides the possibility to use a voltage set-point -10V to +10V resp. a current set-point -20mA to +20mA. Like shown in the figure above this results a turn of the rotation sense. At a positive set point the same correspondence as in "Machine Data-Sense of rotatn." (Page 26) is valid. For negativ set points the inverse sense of rotation is activ.

With activated "monitor ref.val", the device displays fault "ref.val.wire brk" when the setpoint is at least 5% less than the "P1-RV".

To achieve a external current set-point with a 4 ... 20mA - characteristic the set point characteristic has to be adjusted as follows. P1-RV has to be adjusted to 20% corresponding to 4mA. P1-spd, P2-RV and P2-spd may be adjusted dependent on the application (refer to chapter "set-point characteristic" page 29). If a set-point-signal of less than 4mA should lead to a fault "ref.val.wire brk", the "monitor ref. val" has to be activated (see above).

Fix set-points (fix ref.-value)

Binary inputs		Fix ref.-value	Accel/Decel
BE1	BE2		
L-level	L-level	1	1
H-level	L-level	2	2
L-level	H-level	3	3
H-level	H-level	4	4

The FDS frequency inverter provides four adjustable fix ref.-values (FRV1-FRV4). The choice of a fix ref.-value can be done by the use of the binary inputs BE1 and BE2. The table shows the corresponding conditions. If the value of the chosen fix set-point is n=0, the set-point is delivered by the set-point input ("value input"). With choosing the fix ref.-value the four adjustable ramp pairs accel1/dec1-accel4/dec4 are also set, for ramp set and fix ref.-value correspond to each other.

Ramp generator

If only the ramp sets are needed, that can be done by setting the fix ref.-values to n=0. The ramp generator provides four independent ramp pairs (accel1/dec1-accel4/dec4) and a quick stop ramp ("dec q"). The acceleration- and deceleration time can be adjusted separately. The adjusted time is equivalent to the change of the output frequency from 0 to 150 Hz (4 pole motor, gear factor 1 from 0 to 4500 rpm). The choice of a ramp set is done parallel with the fix ref.-value by BE1 and BE2.

See:

Groups, Parameter, Values
Ramp generator pages 24/25

Example of a run-off control by the use of BE1 und BE2

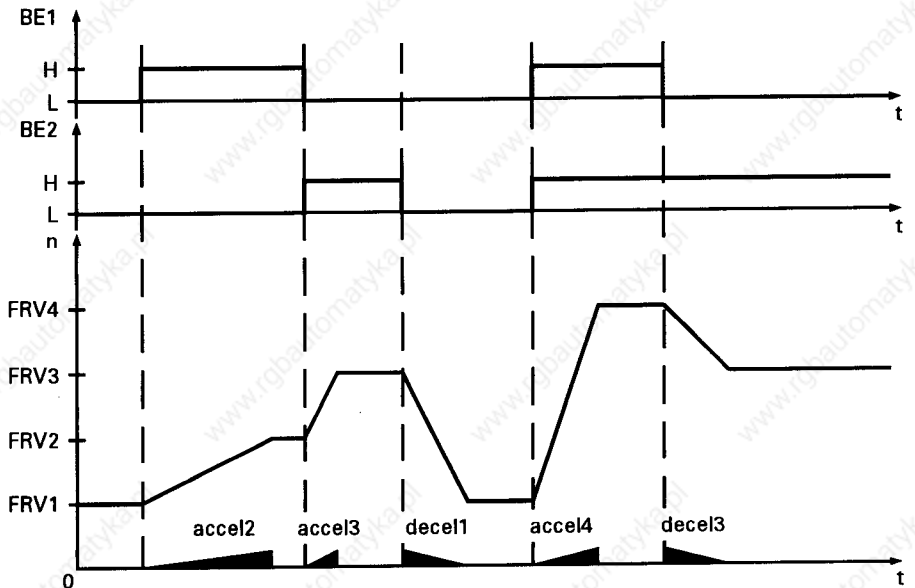

Stop-functions

Quick stop

When activating the quick stop the drive slows down with the ramp "dec q" after taking off the enable input. This happens with two L-level at the rotation sense inputs. It is to be considered that there is no possibility of effecting this stage until the drive is totally stopped. A released quick stop by the enable input leaves the motor currentless at speed $n=0$. A release by the sense of rotation inputs leaves the motor under current. Without a activated quick stop the take off of the enable signal disconnects the current instantly, the drive runs dead.

See:

Drive Conditions pages 18/19

n-monitor

With a active n-monitor a reduce of the output frequency of 10Hz caused by the current limitation (with a 4 pole motor and a gear factor 1 it is 300rpm) will display the warning "n-monitor". When crossing the adjusted time the warning will change into fault "n-monitor".

Auto-start

With activ "auto-start" and a present enable signal (see "Device Data-fault acknowldg.-enable", Page 34) the FDS starts operating after the connection of the mains and a self test. Without the auto-start a L-H-level change at the enable input is necessary to start the drive.

See:

Drive Conditions pages 18/19

Auto-enable

A active auto-start provides an additional enable controlled by the set point (see "Device Data-fault acknowldg.-enable", Page 34). At set points higher than P1-RV the auto-enable enables the drive. At set points under P1-RV the auto-enable locks the drive.

See:

Device Data
Fault acknowldg. page 36
Enable

Customer interface

Binary input BE 3

In this menu point the functions of the binary input BE3, the analog output and the relay output 2 are set.

n-feedback

The binary input BE3 can fulfil four different functions. The functions enable, n- feedback and para.set select are adjustable in this menu point. The function of BE3 as a set-point input is adjusted in the menu point "setting ref.val.-source ref.val". The adjustment of binary input 3 in menu "cntrl.-interface" is inactiv.

Enable

By means of a surge generator (level see "Technical Data", pages 2/3) a n-feedback can be realized with input BE3. The amount of impulses per rotation is to be specified. At minimum and maximum rotation speed the input critical frequency of 10Hz...3KHz shall not be crossed. In the MGS-motor adapter a standard surge generator is included.

Parameter set select

In the function enable, BE3 delivers an additional enable input.

Input BE3 adjusted to the function "para.set select" enables the user to choose between the parameter sets. L-level at BE3 activates parameter set 1, H-level parameter set 2. A change of parameter set will only be acknowledged with "enable off" resp. with activated quick stop function, "enable off" and died motor. The active parameter set will be displayed at the standard display (Page 20/21).

To achieve the maximum flexibility all parameters will be changed with a parameter set select. To avoid unexpected malfunctions the drive has to be designed carefully. All parameters that shall not be changed when changing the parameter set must be adjusted in both parameter sets, but only if the parameter is not of the basic adjustment type. This fact is to be considered especially with the function of BE3. In both parameter sets therefore the function need to be adjusted to "para.set select", to enable the selection from parameter set 1 to 2. Attention is to be payed when parameterizing the "operat. input", "fault acknowldg" and the whole group of stop functions, because with different adjustment of these parameters the device behaviour changes totally with a parameter set change.

See:

Technical Data
Binary inputs pages 2/3
Electrical Installation
Binary inputs-BE3 page 15



Analog-output

The "analog output" delivers the corresponding voltage signal to the adjusted value in Value/Choice. In the following table the possible values and their scales are shown.

Speed (basic adjustment)		0... +10V	-	0 rpm... n-max
Motor voltage		0... +10V	-	0...420V~
Effective power	FBS 2008:	0... +10V	-	0...+1.6kW
	FBS 2013:	0... +10V	-	0...+2.7kW
	FDS 2014:	0... +10V	-	0...+2.9kW
	FDS 2024:	0... +10V	-	0...+4.8kW
	FDS 1030:	0... +10V	-	0...+2.1kW
	FDS 1040:	0... +10V	-	0...+2.8kW
	FDS 1070:	0... +10V	-	0...+5.1kW
	FDS 1085:	0... +10V	-	0...+6.1kW
	FDS 1110:	0... +10V	-	0...+8.1kW
	FDS 1150:	0... +10V	-	0...+11.2kW
	FDS 1200:	0... +10V	-	0...+14.2kW
Motor current		0... +10V	-	0...2* I-N A

Signal flow diagram analog-output

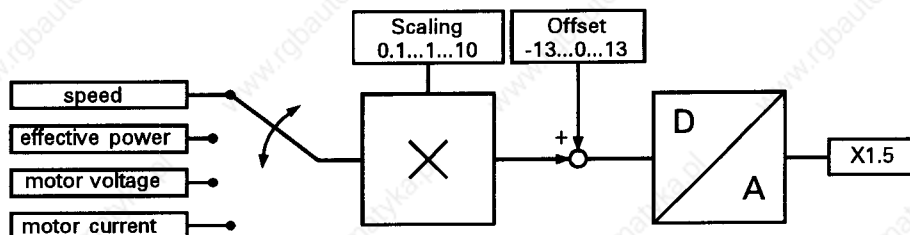

Offset
Scaling

Offset voltages at the analog output can be compensated. A output value can be changed by scaling with a multiply factor. This enables f.e. an adjustment of a display device with a end scale-deflection at less than 10V.

Example:
A display device for monitoring the speed with a end scale-deflection of 5V needs a scale factor of 0.5. The analog output delivers U=5V with n=n-max.

Relay-output 2

The relays output 2 (see Electrical Installation Page 16) can be used to control a brake, for warning or message output, set-point reached ("ref.-val.reached") and I-motor reached ("motorcur. reached").

When the relays output 2 is used for controlling a brake the parameter "brake <...rpm" is to be adjusted to the speed, underneath the brake shall activate when stopping the drive with the inputs "clockwise" or "anti clockwise" (see Machine Data-sense of rotation, Page 26). At that stage the relays contact stays open.

Parameter "brake >...rpm" is to be set to the speed, above the brake shall be released, when the sense of rotation is set and the drive is enabled. When the speed set-point is adjusted to lower values than "brake <...rpm", the relays contact 2 stays open (brake open). With a L-level at at "enable", the brake activates independent of the previous condition.

Control of the brake

In the following table the control of the brake in dependence of the inputs is shown.

Input Enable	Input cw	Input ccw	Brake	Relay Output 2
L-level	xxxxx	xxxxx	activades	open
H-level	L > H-level	L-level	Brake >	closes
H-level	H > L-level	L-level	Brake <	opens
H-level	L-level	L > H-level	Brake >	closes
H-level	L-level	H > L-level	Brake <	opens
H-level	H-level	L > H-level	Brake <	opens

With a warning condition (see Messages, Warnings, Faults Page 35), the relay is closed and can be used for activating a horn or flasher.

When using the relay-output 2 as message contact "ref.-val-reached" the relay is closed at a speed set point+ "-range rpm".

If the relay-output 2 is used as a message contact "motorcur. reached", the relay is closed when "l-act" is higher than "motorcur.> %".

Display Values
Device info.

In this group the device info., the device values of the FDS frequency inverter or the in- and output signals of the cntrl. interface can be displayed.

The "ident-number" can be filed in the FDS. The value is adjustable in the range 0 to 65535. With the ident-number it is possible to identify the device in a plant or in a storage room.

With the parameter set identification "para.-ident" the parameter sets can be assigned a number between 1 and 254. The user now is able to handle 254 parameter sets. When changing a parameter in the activ parameter set the "para.-ident" is automatically set to 255. A change of parameters can be detected instantly. When loading the basic adjustment the "para.-ident" is automatically set to 0.

The "ident-number" and the "para.-ident" can only be set by means of the FDS-Tool software.

Device values

Four internal measured values can be displayed in the point device values.

- Internal voltage
- Motor current
- Apparent power
- Effective power

Customer interface (cntrl.-interface)

In the point customer interface ("cntrl.-interface") the signals of the interface are shown. When commissioning or trouble shooting the signals can be shown comfortably.

See:

Commissioning page 17

Operation

Operation input

The parameter "operat. input" sets, which of the control commands are activ. The control commands are enable, sense of rotation and set point. The change of all other parameters can either be done by keys and display or by parabox or PC without having to specify the source of the parameter.

Service-PC

With the in chapter "Junction cable PC-FDS" described junction cable the FDS frequency inverter can communicate with the optional program FDS-Tool.

This program provides the following possibilities:

- Comfortable, menu guided parameterizing of the FDS
- Remote control with the serial interface
- Fault diagnosis
- Documentation functions for parameter sets and fault diagnosis

**Optional board**

Two optional boards are available for the FDS:

The optional board "interbus" enables the communication according to the DRIVECOM-profil with the Interbus-S © bus system.

Further information see "Installation- and commissioning manual Interbus-S, Communication with the local bus coupling for the FDS frequency inverter series".

The optional board I/O-expansion delivers additional input- output functions for the FDS frequency inverter. The optional board provides a complete microprocessor control circuit with eight binary inputs and dependent on the type with four relays or eight transistor outputs. Several fixed functions are installed. A customer specified function expansion is possible.

Key control

When operating the set point by keys the parameter "operat. input" in the group "Operation" needs to be adjusted to "key control". Then effects a speed decrease effects a speed increase, the ramp is chosen by BE1 and BE2. The amount of speed change per keying can be adjusted by choosing the ramp characteristic. The device need to be enabled, the sense of direction is chosen by the inputs "clockwise" and "anti clockwise".

Actions**Check parameters**

The input parameters are checked on exactness. The following checks are carried out.

- Are the FRV higher than n-max?
- s n-min higher than n-max?
- Crosses the maximum puls frequency/speed the critical frequency of input BE3 (see "cntrl.- interface-n-feedback", page 31)?

Save values

Without saving the values the parameter will be lost after disconnecting the mains.

Basic adjustment

The basic adjustment of all parameters (see "Groups, Parameter, Values", pages 23/24) can be loaded. This values need to be stored afterwards, otherwise they also disappear with the next power disconnect.

Read parabox

A parameterizing of an FDS frequency inverter can be done by reading the parabox data into the FDS. It is performed by releasing the command "read parabox". Therefore the parabox (see Parabox page 22) is to be plugged on the serial interface X3 of the FDS. The device now is adjusted to the corresponding parabox parameters. The values need to be saved with "save values". Exact description see "Manual Parabox".

Write parabox

When releasing "write parabox", with attached parabox at serial interface X3, the whole parameter sets are transfered into the parabox. The number of possible write commands is approx. 10000, the number of read commands nearly unlimited.

Data transfer between FDS and Parabox

After the data transfer between FDS and Parabox the following messages are displayed:

#error free

The data are transfered without errors. Appears at read and write of Parabox.

#identification

Appears when the FDS is prepared for the read of data out of the Parabox. No data is transfered by now. To proceed the action the -key is to be pressed.

#too many values

This message occurs when reading a Parabox with a new software version to a FDS with old software version. The number of parameters in the old version is lower, therefore the supernumery parameters of the new version will not be filed.

#missing values

When reading a Parabox with a old software version to a enlarged parameter set this message will be displayed. This causes that parts of the parameter are not occupied by new parameter, they keep the old parameter.



The following data are not included in the Software Version 2.1 and therefore not transferred:

Group	Parameter	Value
motor data	motor overtemp.	time
machine data	load start	s-spd s-acc
setting reg.val.	ref.val.chract	offset
cntrl.-interface	analog output	offset
display values	device info.	ident-number para.-ident

#invalid data

The occurrence of this message after the action "read parabox" signifies that the Parabox contains invalid data. The reason can be a transmission fault during a writing procedure of the parabox. This results in a new "write parabox". When removing a Parabox from X3 during "read parabox" the message "#invalid data" will be displayed. The FDS sets all parameter sets to the basic adjustment.

#wrong box

Appears when reading or writing a Parabox of version 1.X.

#error

When reading or writing with a defective or without a Parabox this message will be displayed.

Device data

Edit password

The password input is done in "edit password". The first number of the password need to be selected by using the and keys and confirmed by the key. The input of the remaining numbers is done in the same way. With the password 000000 (basic adjustment) the data is not protected.

Fault acknowldg.

The acknowledgement of a fault condition can be done in four different manners:

- **Power-Reset:** The fault is removed by disconnecting the voltage supply.
- **Enable:** A acknowledgement by an enable signal is done with a positive edge at the enable input. It is displayed "ready message/not enabled". The FDS frequency inverter can now be started with another positive edge. The enable of the device consists of three enabling conditions, "input enable, add.enable and auto-enable". To enable the device, all active enables need to be enabled.

Input "Enable"	Input BE3 "add enable"	Auto-Enable	Enable device
L-level H-level	inactive	inactive	not enabled enabled
xxxxx H-level	active: L-level H-level	inactive	not enabled enabled
xxxxx H-level	inactive	active: L-level H-level	not enabled enabled
L-level xxxxx xxxxx H-level	xxxxx L-level xxxxx H-level	xxxxx xxxxx L-level H-level	not enabled not enabled not enabled enabled

- **Auto-restart:** This acknowledgement acknowledges the fault at the FDS and starts the drive automatically. If the drive can not be auto started within five trials, a automatic restart trial is performed each 15 minutes.
- **-Enter:** When acknowledged with the key, the FDS starts operating instantly.



Messages, Warnings, Faults Message

In case of a drive load condition that can not be performed by the FDS frequency inverter the conditions are displayed. A message is displayed even at short time conditions for at least 5s. After disappearance of the cause the message stays five more seconds displayed. The following messages can be displayed:

- *n-reduction*: With too high a load (current limitation) the speed will be reduced.
- *boost I-regul.:* The boost is reduced caused by crossing the current limit (see "Motor Data-Current limitation", Page 25).
- *accel I-regul.:* When crossing the current limit during acceleration the ramp accel will be expanded.
- *decel U-regul.:* At devices without brake resistance the deceleration ramp will be expanded with too high a internal voltage.
- *low voltage:* With too short a acceleration time and low supply voltage the internal voltage breaks down.

See:

Motor Data
Current limitation Page 25

Warning

At warning condition the FDS frequency inverter keeps operating for the adjusted time. Afterwards the device delivers a fault. If the warning condition disappears before run down of the adjusted time, the warning will be canceled. The following messages can be displayed:

- *motor overtemp.:* Motor is overheated caused by overload or lack of cooling.
- *device overtemp.:* Device is overheated caused by overload or lack of cooling.
- *n-monitor:* See "Stop-functions-n-monitor", Page 30

Fault

During operation the following faults can appear:

- *motor overtemp.:* Motor is overheated caused by overload or lack of cooling.
- *device overtemp.:* Device is overheated caused by overload or lack of cooling.
- *n-monitor:* See "Stop-functions-n-monitor", Page 30
- *short/grounded:* Output of device is short cutted or shorted to earth. Too high a load causes too high a current or the ramp times are too short.
- *low voltage:* With a internal voltage under 300V caused by a shut down of the mains, the FDS frequency inverter delivers the fault condition "low voltage". This fault can be acknowledged after the internal voltage crosses 450V. The same fault will be delivered with a voltage drop under 300V during acceleration.
- *high voltage:* Too high a internal voltage caused by high supply voltage or lack of a brake resistance.
- *overload:* The nominal device current is crossed for more than 30s.
- *ref.val.wire brk:* See "Set-Point Adjustment-Set-point monitor", Page 29
- *communication:* The communication with the serial interface X3 could not be constituted.
- *load start:* The drive could not be started with the load start function.
- *hardware defect:* The device is defective.
- *supply 24V:* The external 24V voltage supply does not deliver adequate values (only FDS 1110(B)- FDS 1200(B)).
- *3s ausschalten:* Fault caused by mains interruption. At this fault condition the device is to be switched off for at least 3s.

Interference Elimination Junction Cable PC-FDS Parabox

FBS / FDS



Interference elimination

To provide the demanded class "B" EN55011 of interference suppression (see test certificate) an EMC-pack (see Mechanical Installation, Page 9) can be mounted to the FDS frequency inverter of the series FDS 1040/B-1085/B.

The FDS frequency inverter of the series FDS 1110-1200 provide an internal interference elimination to ensure the observation of interference suppression class "B".

Junction cable PC - FDS

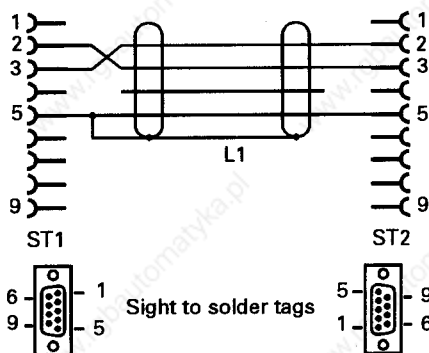

The drawing on the left shows the build up of the junction cable between PC and FDS. The correct function is only provided with the use of the software FDS-Tool.

The junction cable consists of a four leaded data line with a common tinned copper braiding. The leads are of fine-stranded shape.

Operating capacity: 120 nF/km
 Operating voltage: 500 V
 Length: 5m, 10m and 20m
 Outside diameter: approx. 4.8mm

The pin-and-socket connector are Sub-D 9 pole socket boards with solder tags for wire mounting. The flange has got 3.1mm holes without threaded insert. Quality class 2 according to MIL-C--24308

The casing is a bipartited metalized synthetic casing with straight cable entry and internal strain relief.

Parabox

The Parabox is a non volatile memory for the transport of data between PC and FDS and vice versa. It can also be used for filing data sets and programming several FDS with the same data set. Next to the data sets the fault memory can be read and analyzed by means of FDS-Tool.



Accessories

Set-point potentiometer 4.7k Ω with adapter kit	Id.-Nr. 21.828 and 21.829
10-path-potentiometer 5k Ω	Id.-Nr. 22.117
Display to Id.-Nr. 22.117	Id.-Nr. 22.807
Break resistance 300 Ω , 100W (contact protected)	Id.-Nr. 40.374
Break resistance 300 Ω , 150W (contact protected)	Id.-Nr. 40.375
Break resistance 300 Ω , 250W (contact protected)	Id.-Nr. 40.376
Break resistance 100 Ω , 150W (contact protected)	Id.-Nr. 25.863
Break resistance 100 Ω , 600W (contact protected)	Id.-Nr. 27.451
Break resistance 40 Ω , 600W (contact protected)	Id.-Nr. 29.679
Break resistance 30 Ω , 600W (contact protected)	Id.-Nr. 29.568
EMC-pack for FDS 1030/B	Id.-Nr. 64.921
EMC-pack for FDS 1040/B	Id.-Nr. 64.921
EMC-pack for FDS 1070/B	Id.-Nr. 64.922
EMC-Pack for FDS 1085/B	Id.-Nr. 64.923
Analog display 96mm x96mm / 90° (Scala on specification)	Id.-Nr. accord. to type
Digital display 96mm x48mm (3½-digit, max. input 20V)	Id.-Nr. 26.228
FDS-TOOL Software Version 3.2 (3½"-disc)	Id.-Nr. 67.789
FDS-TOOL Software Version 3.2	Id.-Nr. 67.788
Parabox	Id.-Nr. 27.350
Junction cable PC <-> Parabox with Sub-D-connector 9-pole, connector/socket	Id.-Nr. 27.351
Junction cable PC <-> FDS with Sub-D-connector 9-pole, socket/socket	Id.-Nr. 27.352
Adapter Sub-D 9-pole/25-pole connector/socket	Id.-Nr. 27.353
Interbus-S communication accord. DRIVECOM-specification for FDS 1030/B to FDS 1085/B	Id.-Nr. 63.715
Interbus-S communication accord. DRIVECOM-specification for FDS 1110 (B) to FDS 1200 (B)	Id.-Nr. 67.790
Optional board I/O extension for FDS 1030/B - FDS 1085/B	Id.-Nr. 67.791
Optional board I/O extension for FDS 1110(B) - FDS 1200(B)	Id.-Nr. 67.792



Programming example

The programming example below delivers a description of how to change parameters in the basic adjustment. The following parameter will be changed:

1. The nominal point in the group "motor data" will be changed from 50Hz to 87Hz.
2. The ramp set1 will be changed in the group "ramp generator".
Accel will be increased from 3s to 5s and decel will be decreased from 3s to 1s.
3. The changed data will be filed in the group "actions".

Press key			Indication at display	Remarks
			ready not enabled	
1 x			password * * * * * <- - #enter + ->	proceed with #enter with no password stored
1 x			para.-set select 1. <- - #enter + ->	proceed with #enter if no I/O-Extension is mounted
1 x			motor data	
1 x			poles poles 4	
		1 x	type 400V 50Hz	
1 x			400V 50Hz <- - #enter + ->	change frequency value with right or left key
1 x			type 400V 87Hz	new value stored
2 x	or	6 x	motor data	
7 x	or	4 x	ramp generator	
1 x			ramp shape linear	
		1 x	ramp set 1 accel 3,0s	
1 x			accel 1 3,0s <- - #enter + ->	change time with right and left key until the value "5,0s" is reached
1 x			decel 1 3,0s <- - #enter + ->	change time with right and left key until the value "1,0s" is reached
1 x			ramp set 1 accel 5,0s	new values stored
2 x	or	4 x	ramp generator	
6 x	or	5 x	actions	
1 x			check parameters <- #start ->	
		1 x	save values <- #start ->	
1 x			save values #message	values are saved and remain after power disconnect
1 x			save values <- #start ->	
2 x	or	5 x	actions	the FDS will return automatically after 5s to ...
			ready not enabled	

Data Sheet

Device Number: Location:

From the basic adjustment differing parameter data can be noted on this data sheet.



STÖBER ANTRIEBSTECHNIK

motor data

poles: poles
 type: 400V~/ Hz
 u/f-character.: linear square boost %
 current limit: l-motor A l-max % l-hold %
 nominal speed: n-spd rpm
 motor overtemp.: time..... s
 whisper autom.: active inactive

machine data

gear factor: i =
 sense of rotatn.: clockwise cw counter clockwise ccw cw + ccw
 speed limits: n-max rpm n-min rpm
 start-up mode: normal load start cycle character
 n-balance 1-4: n-b.1 rpm n-b.2 rpm n-b.3 rpm n-b.4 bpm
 load start: s-spd rpm s-acc s

setting ref.val.

source ref.val.: 0...+10V 0...20mA 0,1...3,0kHz motor potentiometer
 ref.val.character: P1-RV % P1-spd rpm P2-RV % P2-spd rpm
 offset %
 monitor ref.val.: inactive activ

fix ref. value

fix ref.-value 1: FRV1 rpm fix ref.-value 2: FRV2 Upm
 fix ref.-value 3: FRV3 rpm fix ref.-value 4: FRV4 rpm

ramp generator

ramp shape: linear smothened
 ramp set 1: accel1 s/150 Hz decel1 s/150 Hz
 ramp set 2: accel2 s/150 Hz decel2 s/150 Hz
 ramp set 3: accel3 s/150 Hz decel3 s/150 Hz
 ramp set 4: accel4 s/150 Hz decel4 s/150 Hz

stop functions

quick stop: inactive active decel-s s
 n-monitor: inactive active time s
 auto-start: inactive active
 auto-enable: inactive active

cntrl. interface

input BE 3: inactice add.enable n-feedback n-fdbk I/U
 analog-output: speed effective power motor voltage M motor current
 offset scaling
 relay-output 2: brake on ref.-val reached motorcur.reached warning
 brake < rpm brake > rpm range rpm l-motor > %

display values

device info.: FDS software modification
 optional board ident-number para-ident
 device values: internal voltage motor current apparent power effective power
 cntrl. interface: ref.-value input ENA/CW/CCW BE1/BE2/BE3 analog-output
 ready messag. relay output 2

operation

operat. input: cntrl.-interface service-PC Interbus-S
 key control

device data

edit password: password
 fault acknowldg.: power-reset enable auto-receipt #enter

Modular mimic display
 FBS 2008/B
 FBS 2013/B
 FDS 2014/B
 FDS 2024/B

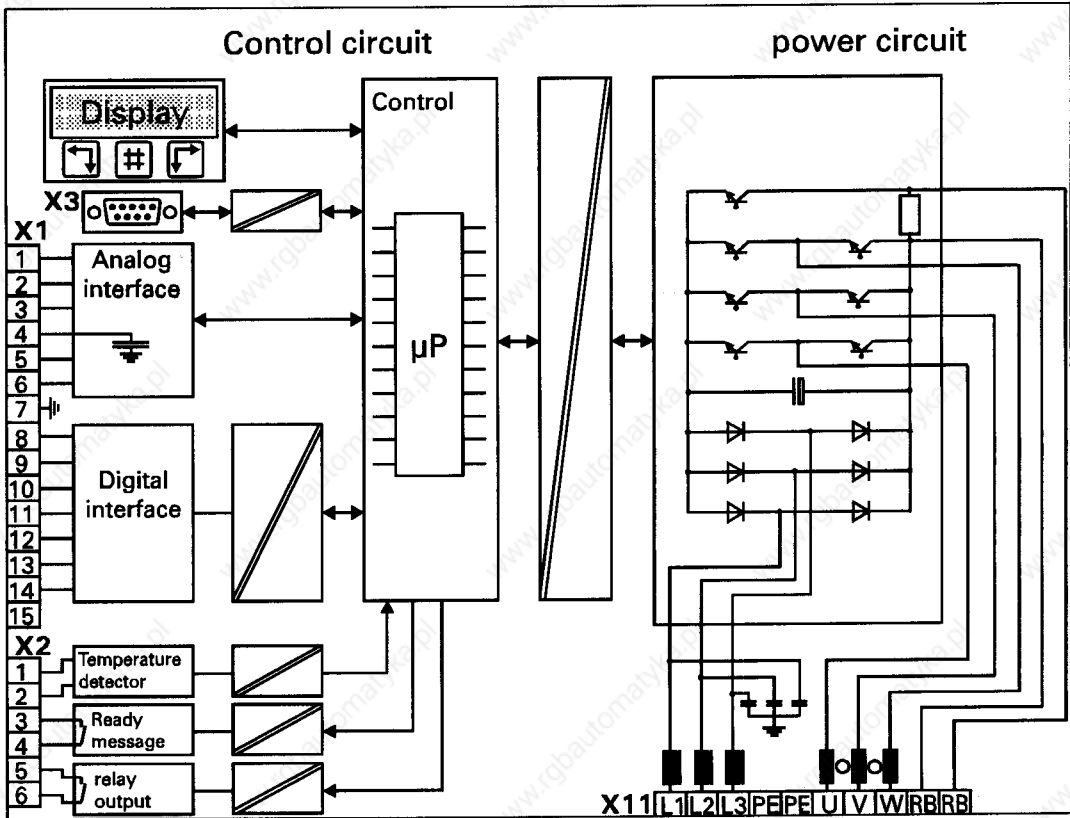

Modular mimic display
 FDS 1030/B
 FDS 1040/B
 FDS 1070/B
 FDS 1085/B

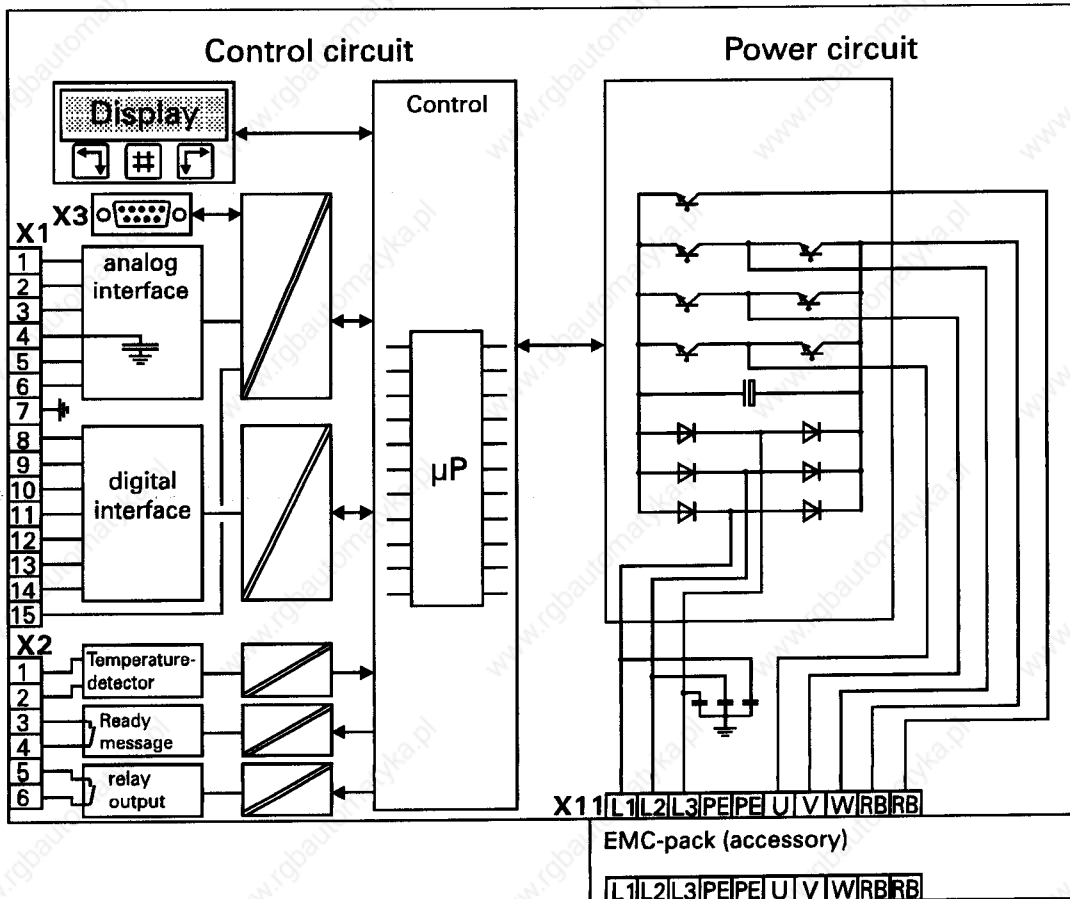

Modular mimic display
 FDS 1110 (V/B)
 FDS 1150 (V/B)
 FDS 1200 (V/B)

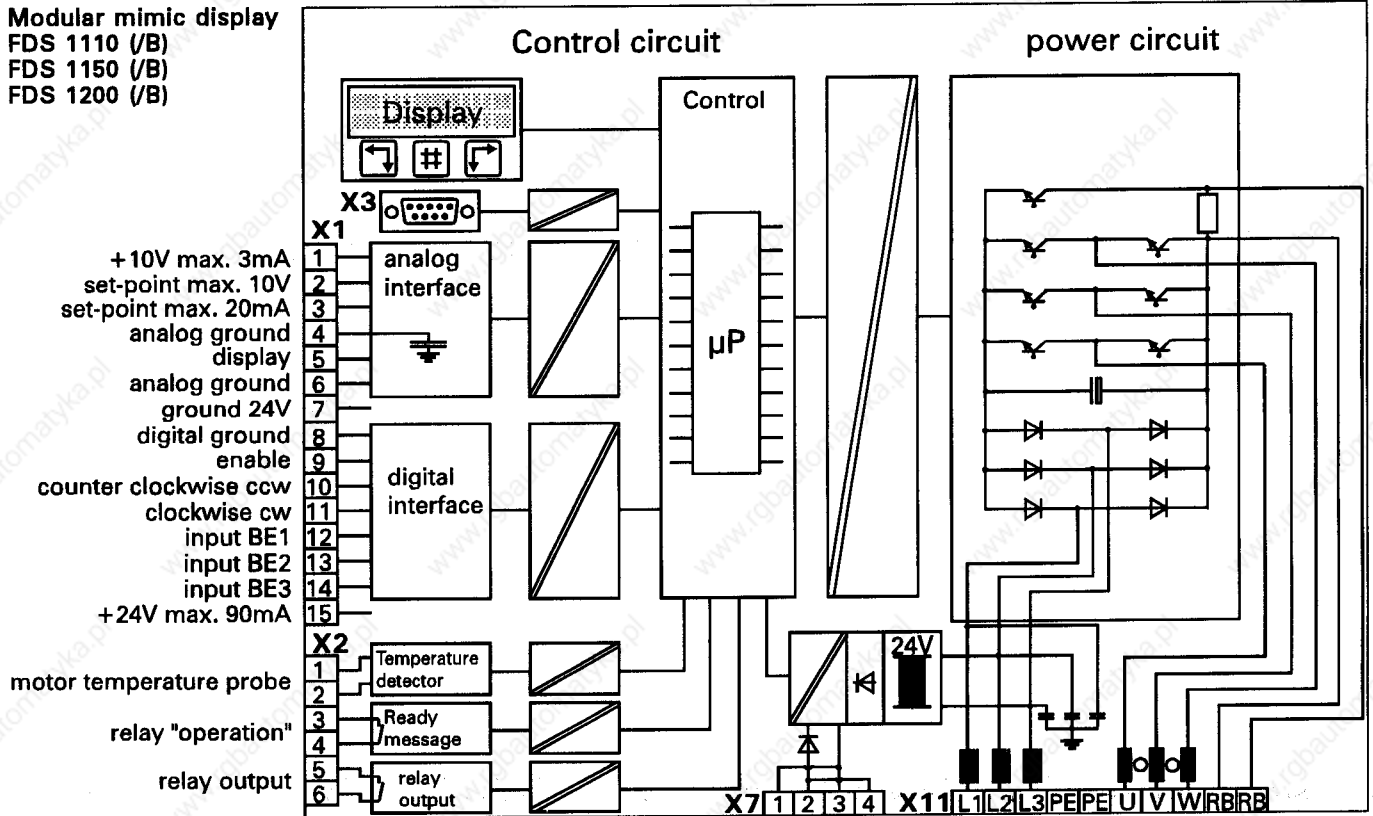



Voltage test of electrical installation

To voltage test a complete electrocal installation (f. e. a electrical industrial machine according to VDE 0113) with included FDS frequency inverter, the following potentials of the FDS frequency inverter need to be considered:

- a.) PE-potential and customer interface potential
Terminals X11.PE and the PE-terminal, terminals X1.1 to X1.15, terminals X2.1 to X2.6, terminals X3.1 to X3.9 (and terminals X1.A, X1.B and X7.1 to X7.4, if present)
- b.) Power potential
Terminals X11.L1 to X11.W without the two X11.PE terminals (and both X11.RB terminals if present).



Within the individual potentials the terminals need to be short cutted while voltage testing in order to avoid device damage.

Potential a) is tested against potential b) using the following testing parameters:

- HV testing equipment
- maximum allowable test voltage 2000V AC
- trigger current 80mA
- test duration 1s

Testing parameters:

The test is passed when no flashover, disruptive breakdown or permanent changes of the insulation materials is detected.

STÖBER ANTRIEBSTECHNIK - Deutschland



STÖBER ANTRIEBSTECHNIK

Hauptverwaltung:

STÖBER ANTRIEBSTECHNIK GmbH & Co.

Postfach 910103
75091 Pforzheim

Kieselbronner Straße 12
75177 Pforzheim

Telefon (0 72 31) 5 82-0
Telefax (0 72 31) 5 82-1 97
eMail sales@stoeber.de

24-Stunden-Service-Nr.

(0 18 05) 78 63 23

Vanity-No:

(0 18 05) STOEBER

Vertriebsgebiet Nordwest:

Zentrale

STÖBER ANTRIEBSTECHNIK GmbH & Co.

Klaus Sirrenberg
Friedrich-Ebert-Str. 85
58454 Witten

Telefon (0 23 02) 98 49 4-0
Telefax (0 23 02) 98 49 4-50
eMail TB_DO@stoeber.de

Zugehörige Technische Büros:

Norddeutschland

20000 - 23919
24000 - 29999

STÖBER ANTRIEBSTECHNIK GmbH & Co.

Stefan Hildebrandt
Hellwege Allee 9b
21698 Harsefeld

Telefon (0 41 64) 81 19 04
Telefax (0 41 64) 81 19 05
eMail TB_ND@stoeber.de

Münster

33000 - 33599
33900 - 33999
48000 - 49999
59200 - 59329
59470 - 59699

STÖBER ANTRIEBSTECHNIK GmbH & Co.

Markus Merker
Grottenkamp 28
48565 Steinfurt

Telefon (0 25 52) 61 02 71
Telefax (0 25 52) 61 02 72
eMail TB_MS@stoeber.de

Dortmund Nordwest

40000 - 47999
59330 - 59399

STÖBER ANTRIEBSTECHNIK GmbH & Co.

Thomas Nickisch
Friedrich-Ebert-Str. 85
58454 Witten

Telefon (0 23 02) 98 49 4-0
Telefax (0 23 02) 98 49 4-50
eMail TB_DO@stoeber.de

Dortmund Südost

50000 - 53999
57000 - 59199
59400 - 59469
59700 - 59999

STÖBER ANTRIEBSTECHNIK GmbH & Co.

Michael Ritter
Friedrich-Ebert-Str. 85
58454 Witten

Telefon (0 23 02) 98 49 4-0
Telefax (0 23 02) 98 49 4-50
eMail TB_DO@stoeber.de

Hannover

30000 - 32999
33600 - 33899
34330 - 34549
37000 - 37199
37400 - 38799

STÖBER ANTRIEBSTECHNIK GmbH & Co.

Alexander Helmes
Birkenweg 6
32839 Steinheim

Telefon (0 52 33) 99 77 65
Telefax (0 52 33) 99 77 67
eMail TB_H@stoeber.de

Vertriebsgebiet Mitte:

Zentrale

STÖBER ANTRIEBSTECHNIK GmbH & Co.

Postfach 910103, 75091 Pforzheim
Kieselbronner Straße 12, 75177 Pforzheim

Telefon (0 72 31) 58 20
Telefax (0 72 31) 58 21 97
eMail sales@stoeber.de

Zugehörige Technische Büros:

Saar-Pfalz

54000 - 56999
65000 - 66919
67200 - 67319
67500 - 67999

STÖBER ANTRIEBSTECHNIK GmbH & Co.

Roland Dillmann
Black & Decker-Str. 1
65510 Idstein

Telefon (0 61 26) 98 94 06
Telefax (0 61 26) 5 54 99
eMail TB_ID@stoeber.de

Wiesbaden

34000 - 34329
34550 - 36399
37200 - 37299
60000 - 64999

STÖBER ANTRIEBSTECHNIK GmbH & Co.

Jens Thomas
Black & Decker-Str. 1
65510 Idstein

Telefon (0 61 26) 98 94 05
Telefax (0 61 26) 5 54 99
eMail TB_ID@stoeber.de

Vertriebsgebiet Süd:

Zentrale

STÖBER ANTRIEBSTECHNIK GmbH & Co.

Postfach 910103, 75091 Pforzheim
Kieselbronner Straße 12, 75177 Pforzheim

Telefon (0 72 31) 58 20
Telefax (0 72 31) 58 21 97
eMail sales@stoeber.de

STÖBER ANTRIEBSTECHNIK - Deutschland



STÖBER ANTRIEBSTECHNIK

Zugehörige Technische Büros:

Pforzheim

70000 - 71499
71600 - 71999
72190 - 72299
74000 - 74399
74600 - 74699
75100 - 75999

Gerd Braun GmbH

Ingenieurbüro für Antriebstechnik
Gerd Braun, Dirk Petersen
Adolf-Sautter-Str. 30
75181 Pforzheim (Würm)
eMail mail@braun-antriebstechnik.de

Telefon (0 72 31) 97 99 0
Telefax (0 72 31) 97 99 10

Nordbaden

66920 - 67199
67320 - 67499
68000 - 69999
74700 - 75099
76600 - 76999
97860 - 97999

STÖBER ANTRIEBSTECHNIK GmbH & Co.

Stefan Rotterdam
Postfach 910103, 75091 Pforzheim
Kieselbronner Straße 12, 75177 Pforzheim

Telefon (0 72 31) 58 21 49
Telefax (0 72 31) 58 23 49
eMail TB_NB@stoeber.de

Südbaden

76000 - 76599
77000 - 77999
78090 - 78149
79000 - 79999

STÖBER ANTRIEBSTECHNIK GmbH & Co.

Daniel Lohse
Postfach 910103, 75091 Pforzheim
Kieselbronner Straße 12, 75177 Pforzheim

Telefon (0 72 31) 58 21 14
Telefax (0 72 31) 58 23 49
eMail TB_SB@stoeber.de

Reutlingen

72000 - 72189
72300 - 72999
78000 - 78089
78150 - 78999
88000 - 89299
89570 - 89999

STÖBER ANTRIEBSTECHNIK GmbH & Co.

Wilhelm Haydt
Gerh.-Hauptmann-Str. 53
72793 Pfullingen

Telefon (0 71 21) 99 40 35
Telefax (0 71 21) 99 40 36
eMail TB_RT@stoeber.de

Göppingen

71500 - 71599
73000 - 73999
74400 - 74599
89500 - 89569

Rolf P. Ulrich

Ingenieurbüro für Antriebstechnik
Rolf P. Ulrich
Eichendorffstraße 19
73072 Donzdorf

Telefon (0 71 62) 2 12 74
Telefax (0 71 62) 2 40 61
eMail TB_GP@stoeber.de

München

80000 - 84999
85200 - 87999
89300 - 89499
94000 - 94999

STÖBER ANTRIEBSTECHNIK GmbH & Co.

Rupert Schweiger
Feuerreit 1
85625 Baiern

Telefon (0 80 65) 18 02 32
Telefax (0 80 65) 18 02 33
eMail TB_M@stoeber.de

Nürnberg

85000 - 85199
90000 - 93999
95000 - 96499
97000 - 97859

STÖBER ANTRIEBSTECHNIK GmbH & Co.

Wolfgang Lukas
Industriestraße 20 a
91353 Hausen

Telefon (0 91 91) 73 45 37
Telefax (0 91 91) 73 45 38
eMail TB_N@stoeber.de

Vertriebsgebiet Ost:

Zentrale

STÖBER ANTRIEBSTECHNIK GmbH & Co.

Postfach 910103, 75091 Pforzheim
Kieselbronner Straße 12, 75177 Pforzheim

Telefon (0 72 31) 58 20
Telefax (0 72 31) 58 21 97
eMail sales@stoeber.de

Zugehörige Technische Büros:

Berlin / Brandenburg

06000 - 06599
06730 - 07299
10000 - 19999
23920 - 23999
38800 - 39999

STÖBER ANTRIEBSTECHNIK GmbH & Co.

Bernd Weise
Werneuchener Weg 9
15345 Altlandsberg

Telefon (03 34 38) 57 31
Telefax (03 34 38) 57 32
eMail TB_BR@stoeber.de

Lichtenstein

00000 - 05999
06600 - 06729
07300 - 09999
36400 - 36999
37300 - 37399
96500 - 96999
98000 - 99999

STÖBER ANTRIEBSTECHNIK GmbH & Co.

Jürgen Stolper
Günsbacher Straße 4
09350 Lichtenstein

Telefon (03 72 04) 29 85
Telefax (03 72 04) 29 86
eMail TB_LI@stoeber.de

STÖBER ANTRIEBSTECHNIK - International



STÖBER ANTRIEBSTECHNIK

Austria	STÖBER ANTRIEBSTECHNIK GmbH Fabriksplatz 1 4662 Steyrermühl	Phone +43 (0) 76 13 / 7 60 00 Fax +43 (0) 76 13 / 7 60 09 eMail office@stoerber.at
France	STÖBER S.a.r.l. 47, rue Maurice Flandin 69003 Lyon	Phone +33 (0) 4 / 72 13 24 38 Fax +33 (0) 4 / 72 13 24 57 eMail mail@stoerber.fr
Great Britain	STOBER DRIVES LTD. Unit 9, Abbeymead Industrial Park Brooker Road, Waltham Abbey Essex EN9 1HU	Phone +44 (0) 19 92 / 70 97 10 Fax +44 (0) 19 92 / 71 41 11 eMail mail@stoerber.co.uk
Italy	STÖBER TRASMISSIONI S. r. l. Via Risorgimento, 8 20017 Mazzo di Rho (Milano)	Phone +39 02 / 93 90 95 70 Fax +39 02 / 93 90 93 25 eMail info@stoerber.it
Korea	DAE KWANG STOEBER CO. LTD. 441-10 Sangdewon-dong, Joongwon-ku, Sungnam-city, Kyuunggi-do, Postcode 462-120	Phone +82 (0)31 / 7 35 02 93 Fax +82 (0)31 / 7 36 02 81 eMail dkstoerber@netsgo.com
Poland	STOEBER POLSKA ul.H.Kamienskiego 201-219 51-126 Wrocław	Phone +48 (0) 71 / 3 20 74 17 Fax +48 (0) 71 / 3 20 74 17 eMail biuro@stoerber.pi.pl
USA	STOBER DRIVES INC. 1781 Downing Drive Maysville, KY 41056	Phone +1 6 06 / 7 59 50 90 Fax +1 6 06 / 7 59 50 45 eMail sales@stoerber.com
Belgium	VAN DOREN - PILLE N. V. Industrieterrein De Prijckels Venecoweg 25 9810 Nazareth	Phone +32 9 / 2 52 13 09 Fax +32 9 / 2 52 23 74 eMail info@vandorenpille.be
Brasil	FRAPHE COMERCIAL Ltda. Rua Jaragua, 340 Bom Retiro 01129-000 Sao Paulo, SP	Phone +55 (0) 11 / 33 37 57 87 Fax +55 (0) 11 / 33 33 42 00 eMail fraphe@fraphe.com.br
Bulgaria	Z & M PRIVATE COMPANY 5, Angel Kantchev Str. 1000 Sofia	Phone +359 2 / 9 86 58 55 Fax +359 2 / 9 86 59 16 eMail zandm@techno-link.com
China	WK-INTERSALES BEIJING German Centre Unit 0525-0530, Landmark Tower 2 8 North Dongsanhuan Road Chaoyang District Beijing 100004	Phone +86 (0) 10 / 65 90 64 25 + 26 Fax +86 (0) 10 / 65 90 67 85 eMail intersal@public.east.net.cn
Colombia	SOCOMEX LTDA. Apdo. Aereo 11606 Santafe de Bogota D. C.	Phone +57 2 85 61 05 / +57 2 85 64 96 +57 2 85 63 36 Fax +57 13 35 04 87

STÖBER ANTRIEBSTECHNIK - International



STÖBER ANTRIEBSTECHNIK

Denmark	EEGHOLM A/S Grundtvigs Allé 165-169 P. O. Box 190 6400 Sønderborg	Phone +45 / 73 12 12 12 Fax +45 / 73 12 12 13 eMail eegholm@eegholm.dk
Finland	EIE MASKIN OY PL 80 10600 Tammisaari	Phone +358 (0) 19 / 2 46 16 42 Fax +358 (0) 19 / 2 46 16 43 eMail eie@eie.fi
Hungary	BDI Hungary Ltd. Fóti Street 141, Bldg 37. 1046 Budapest	Phone +36 (0) 1 / 2 31 10 10 Fax +36 (0) 1 / 2 31 10 30 eMail bdi-hun@elender.hu
the Netherlands	MIJNSBERGEN B. V. Postbus 166 3640 AD Mijdrecht	Phone +31 (0) 2 97 / 28 58 21 Fax +31 (0) 2 97 / 27 23 26 eMail mijnsbergen@mijnsbergen.nl
Norway	ELMEKO AS Postbox 80 1306 Baerum Postterminal	Phone +47 / 67 57 22 70 Fax +47 / 67 57 22 80 eMail elmeko@elmeko.no
Peru	POWERMATIC S. A. Av. Los Ingenieros 333 Lima 03	Phone +51 (0) 1 / 3 49 01 84 / 3 49 40 11 Fax +51 (0) 1 / 4 37 00 73 eMail powermatic@terra.com.pe
Philippines	LEELENG COMMERCIAL, INC. 387 - 393 Dasmariñas St. P. O. Box 480 Manila	Phone +63 2 / 2 41 89 01 to 05 Fax +63 2 / 2 41 40 60 eMail leeleng@manila.vasia.com
South Africa	BEARING MAN LTD. P. O. Box 33431 Jeppestown 2043	Phone +27 (0) 11 / 6 20 15 00 Fax +27 (0) 11 / 6 20 17 75 eMail sales@bearing_man.co.za
Spain	TAHFER COMERCIAL, S. A. Jesus, 27 28917 - LA FORTUNA	Phone +34 91 / 6 19 34 24 Fax +34 91 / 6 19 77 92 eMail tahfercom@tahfer.com
Sweden	EIE MASKIN AB Postfach 7 12421 Bandhagen	Phone +46 (0) 8 / 7 27 88 00 Fax +46 (0) 8 / 7 27 88 99 eMail eie@eie.se
Switzerland	INDUR ANTRIEBSTECHNIK AG Margarethenstraße 87 4008 Basel	Phone +41 (0) 61 / 2 79 29 00 Fax +41 (0) 61 / 2 79 29 10 eMail info@indur.ch
Thailand	GERMAN ENGINEERING & MACHINERY CO., LTD. 947/161 Bangna Complex Moo 12 Bangna Trad Rd. Km 3 Bangkok 10260	Phone +66 2 / 3 61 90 82-8 Fax +66 2 / 3 61 90 89
Turkey	YÜRE MAKINA SAN. ve TIC. LTD. STI. Fevzi Çakmak Mah. 5. Cad. 19. Sok. No: 13 34200 ESENLER-ISTANBUL	Phone +90 2 12 / 6 28 55 73 Fax +90 2 12 / 6 28 55 73

www.rgbautomatyka.pl

20.04.95

Impressum: PBS • Nr.440 698 • ---- • 04.95 • 100

-The technical data and information herein is subject to change without notice-