

Betriebsanleitung  
Operating Instructions

Druckschrift Nr.  
Publication No.  
D EA 5249 89a DE

AXODYN® - Gleichstrom-  
Drehzahlregelgeräte  
für 4-Quadrantenbetrieb  
AXODYN®  
DC Speed Regulators  
for 4-Quadrant Operation

**Typenreihe/Series 05 SM....**

# List of contents

	Page
Component layout plan of series 05 SM....	2a
Block diagram of series 05 SM....	2b
<b>1. Preparatory work</b>	<b>3</b>
1.1 General checks on motor	3
1.2 Checks and adjustments on the disconnected unit	3
1.3 Connection examples	4
1.3.1 Connection example for a single-axis system with card holder 05 SK 8001	4
1.3.2 Connection example for a multi-axis system with subrack 05 SR 81....	5
1.4 Checking of connections	6
1.5 Calculation of tach feedback adaptation	6
<b>2. Parametrization and display board 05 SM...</b>	<b>7</b>
2.1 Handling of parametrization and display board	8
2.2 Display function "Master/Slave"	8
<b>3. Initial motor start-up</b>	<b>9</b>
3.1 Checks and adjustments on the disconnected unit	9
3.2 Application of motor voltage	9
3.2.1 Adjustment of tach monitoring function	9
3.3 Adjustment of current	9
3.4 Adjustment of maximum speed	9
3.5 Offset voltage balancing	9
3.6 Speed regulator optimization	10
3.6.1 Speed control with P-component only	10
3.6.2 Internal presetting of zero speed reference	10
3.7 Current limitations	11
3.7.1 Limitation through external reference	11
3.7.2 Adjustment of motor high current	11
3.7.3 Adjustment of rated motor current	12
3.7.4 Limitation through increased ambient temperature > 45°C	12
3.7.5 Speed-dependent current reduction (option)	12
3.7.6 Circuit monitoring the "Operating time at RMS current"	12
3.8 Current control	12
3.9 Armature voltage control with I·R compensation	12
3.10 External output stage blocking (Stand by)	13
3.10.1 Delayed output stage blocking	13
3.10.2 External output stage blocking via opto-isolated 24 V inputs	13
3.11 Limit switch functions	13
<b>4. Instructions referring to operation of unit connected to a superordinated control system</b>	<b>14</b>
<b>5. Functions of terminals</b>	<b>15</b>
5.1 Functions of terminals of card holder SK 8001 for single-axis system	15
5.2 Functions of terminals of subrack 05 SR..	16
5.2.1 Functions of terminals for each axis	16
5.3 Functions of terminals of supply transformer DTK....	17
5.4 Functions of terminals of smoothing choke GD..	17
<b>6. Measuring points, jumpers</b>	<b>18</b>
6.1 Measuring points	18
6.2 Jumpers	18
<b>7. Fusing</b>	<b>19</b>
7.1 Internal fusing of 05 SM	19
7.2 External fusing	19
7.3 Fusing of braking modules 05 SB....	19
<b>8. Start-up of braking modules</b>	<b>20</b>
8.1 Start-up of braking modules 05 SB8111 (single-axis applications)	20
8.2 Start-up of braking modules 05 SB8211 and 05 SB8411	21
8.2.1 Mode of operation of braking modules	21
8.2.2 Parametrization and display board of 05 SB 8211 and 05 SB 8411	22
8.2.3 STATE/ALARM display field of braking modules 05 SB 8211 and 05 SB 8411	22
8.2.4 Arrangement of jumpers and fuses on modules 05 SB 8211 and 05 SB 8411	22
<b>9. Fault and state signals (STATE/ALARM)</b>	<b>23</b>
<b>10. Diagnosis of drive system faults</b>	<b>24</b>
<b>11. Drive packages, characteristic data and adjustments</b>	<b>25</b>
<b>Report on modifications/adjustments performed: Supplement D EA 5249 89a/1 DE</b>	

**Bestückungsplan Typenreihe 05 SM... / Component layout plan of series 05 SM...**

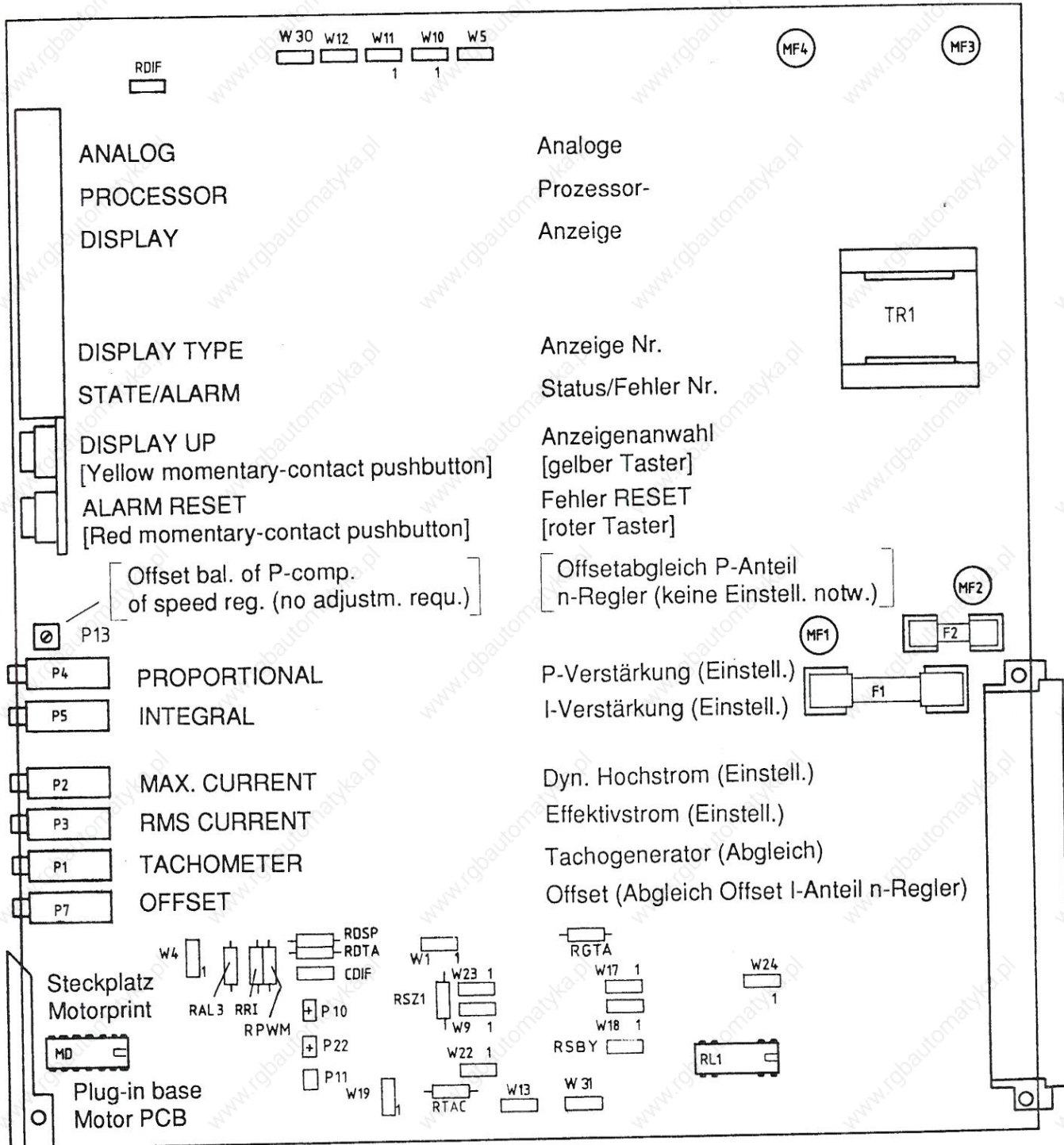

MF1 bis MF4 sind Befestigungspunkte für das Bremsmodul 05 SB8111 bei Einachs-anwendung.  
 MF1 to MF4 are points to be used for fixing braking module 05 SB8111 employed in single-axis applications.



# Blockschaltbild Typenreihe 05 SM... / Block diagram of series 05 SM....

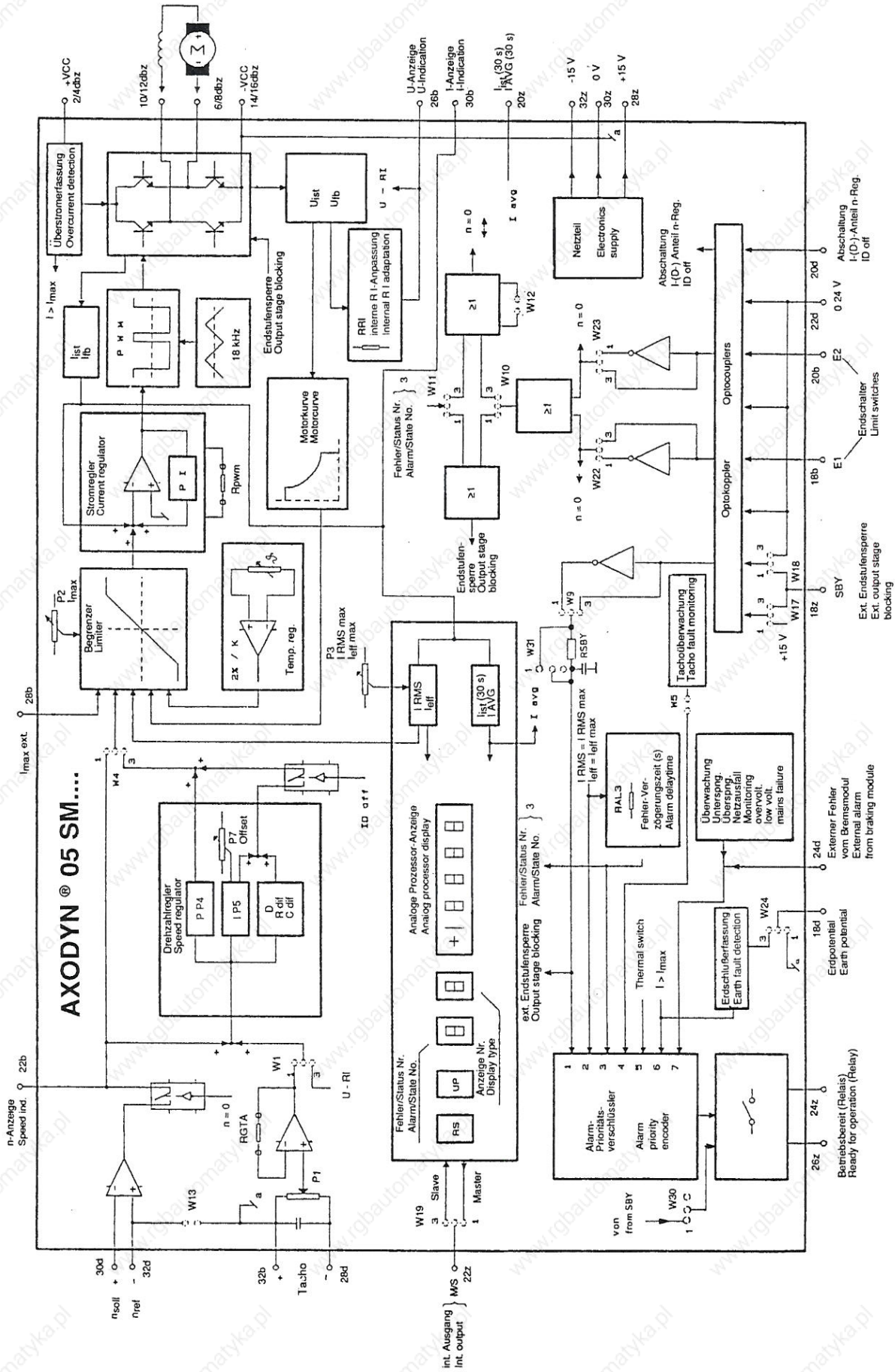

**Achtung: Klemmenbezeichnungen direkt an der Reglerkarte 05 SM; nicht identisch mit Klemmenplan Baugruppenträger 05 SR... oder Kartenhalter 05 SK...  
 Important: Terminal designations given directly on the regulator card 05 SM; not identical with the terminal connection diagram of subrack 05 SR... or card holder 05 SK...**



# 1. Preparatory work

## 1.1 General checks on motor

- Armature: connections
- Carbon brushes: condition, bearing surface, brush pressure
- Tach: connections, carbon brushes
- Readiness for operation: oil, brake, locking device, gearing, etc.

## 1.2 Checks and adjustments on the disconnected unit, e.g. mains fuses removed

- Check 05 SM unit and accessories for possible damage caused during transportation or assembly. Check main and control leads for proper and tight connection.
- Check jumpers for proper installation on speed regulator. With standard components (as delivered by ABB) of the regulator cards, the jumpers must be installed on the positions given below. For positions also see the component layout plan given on the front flap.

No.	Standard configuration (as delivered by ABB)
W1	1-2
W4	2-3
W5	Installed
W9	1-2
W10	Open
W11	Open
W12	Open
W13	Open
W17	1-2
W18	1-2
W19	2-3
W22	2-3
W23	2-3
W24	1-2
W30	1-2
W31	1-2

- Important checks to be performed on subrack 05 SR.... equipped with 05 SM.... regulators: The subrack slot on the farthest left (next to the capacitors) is reserved for braking module 05 SB8211 or 05 SB8411. This slot must **not** be used for plugging in 05 SM.... axis-speed regulator modules.
- Check proper contacting of the axis-speed regulator modules.
- When sliding modules into the subrack, check for proper locking.
- Check proper contacting of the motor PCB, if any.

### 1.3 Connection examples

#### 1.3.1 Connection example for a single-axis system with card holder 05 SK 8001

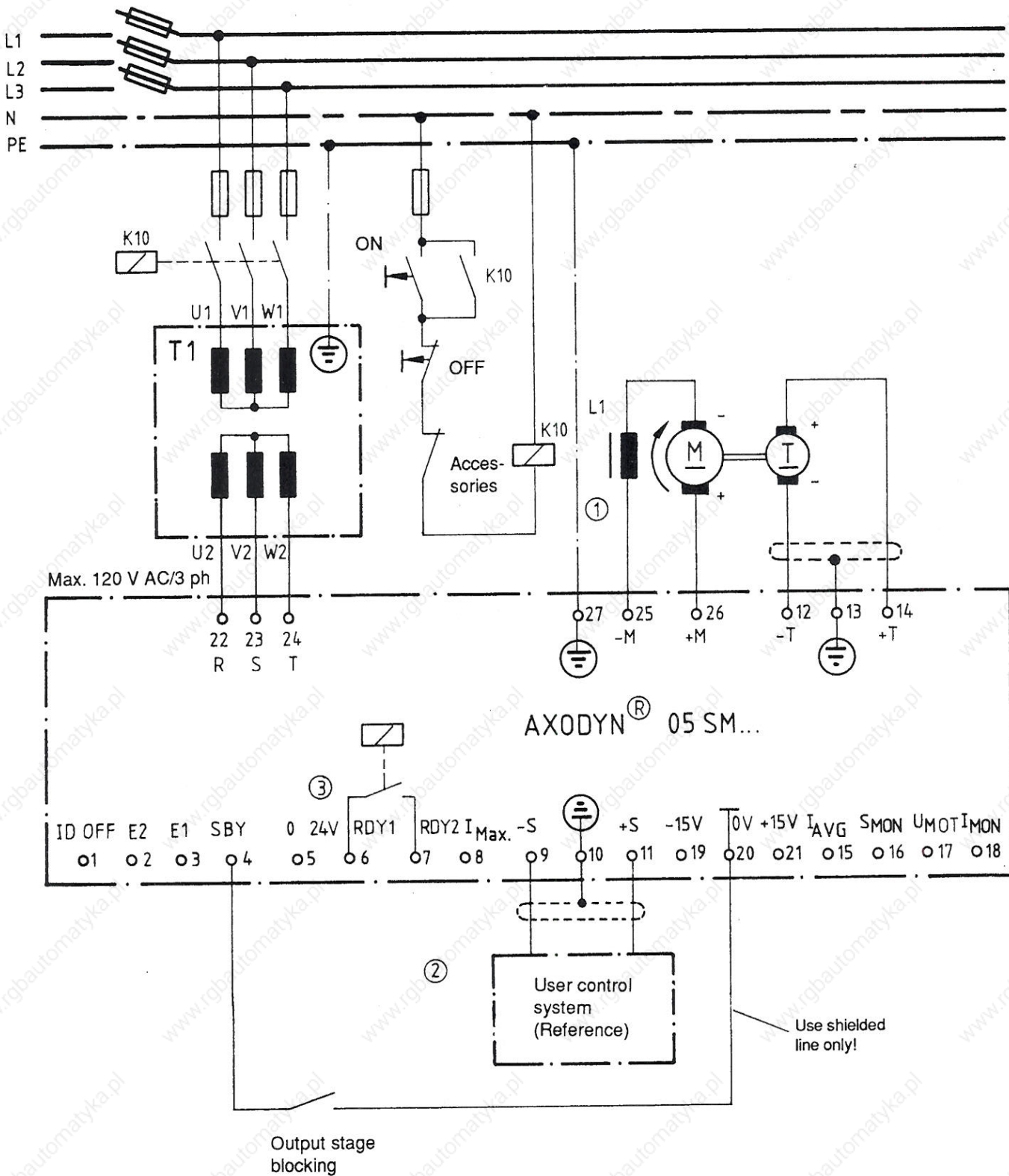

① DC smoothing choke L1 is only required for some motor types; see chapter 11. Drive packages

② For reference presetting via potentiometer refer to chapter 1.4

③ Reference potential 0V for opto-isolated signal inputs E1, E2, ID OFF, SBY

### 1.3.2 Connection example for a multi-axis system with subrack 05 SR 81..

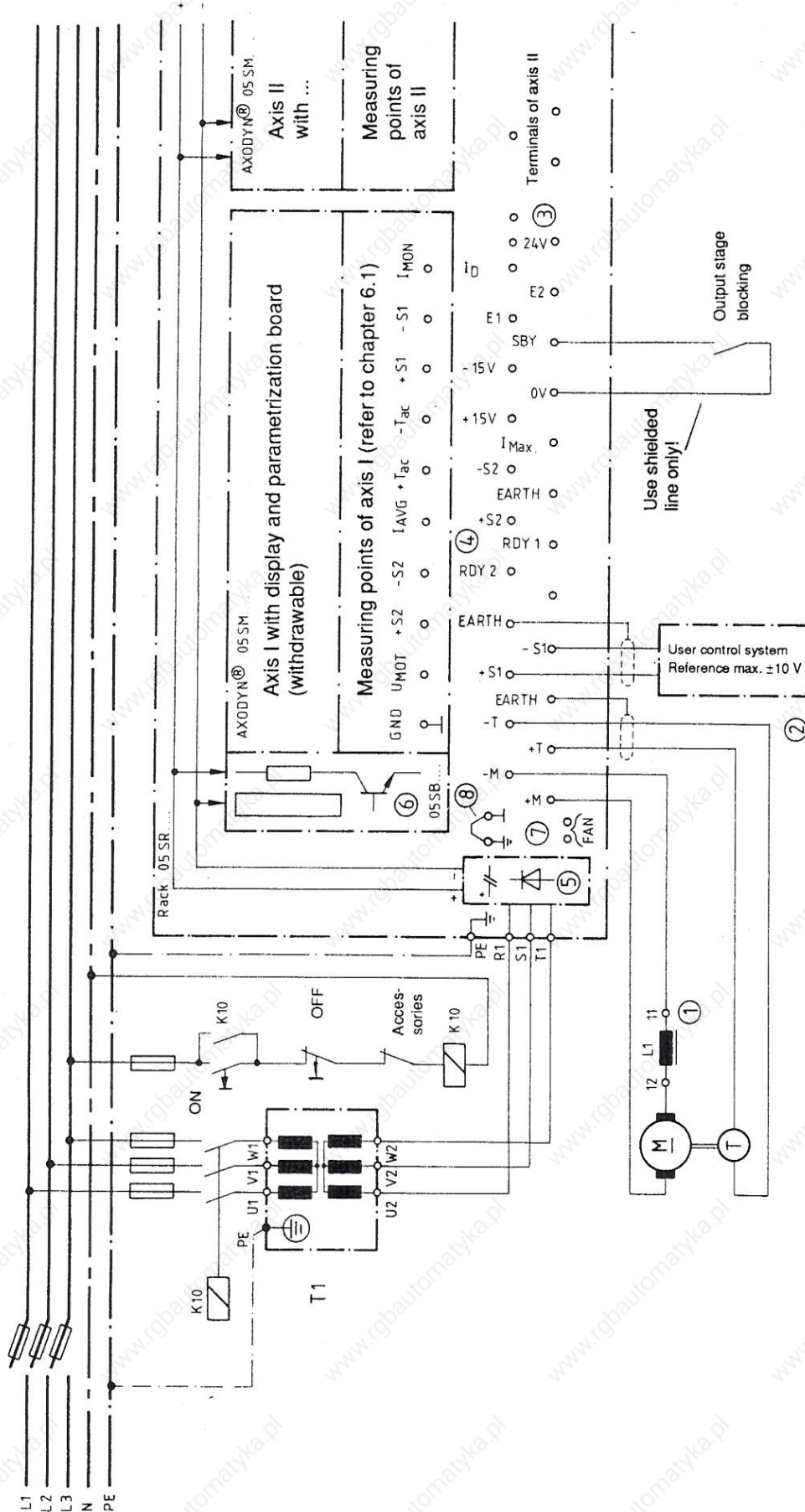

- ① DC smoothing choke L1 is only required for some motor types (see chapter 11. Drive packages)
- ② For reference presetting via potentiometer refer to chapter 1.4
- ③ Reference potential 0V for opto-isolated signal inputs E1, E2, ID OFF, SBY
- ④ Relay indicating "READY FOR OPERATION", max. contact rating 100 V, 0.1 A
- ⑤ Subrack can also be equipped with 2 power rectifiers
- ⑥ Braking module 05 SB has to be plugged in next to power rectifier! This slot next to the power rectifier must not be used for applications without braking module.
- ⑦ Fan supply 220 V AC only for subracks with fan, current input 0.1 A per fan
- ⑧ 0V connection between PE ⊕ and ELECTRONICS COMMON, as delivered by ABB. Remove jumper for earth-fault detection.



## 1.4 Checking of connections

- Check mains connections R, S, T at the speed regulator.  
Max. incoming supply 120 V AC/3-ph,  $\pm 10\%$ .
  - Motor connection:  
positive motor terminal connected to M+  
negative motor terminal connected to M-
  - Tach connection:  
positive tach terminal connected to T+  
negative tach terminal connected to T-
- for clockwise rotating motor with a positive reference voltage at S1

Connect shield to EARTH terminal. For balancing of tach refer to the chapter dealing with "Adjustments".

- Connection for output stage blocking:  
Contact (NO contact between terminals 0V and SBY (stand-by), or for release, connection of 0V to terminal SBY  
**Attention: Prior to initial start-up, the SBY contact must be open.**

- Connection for reference presetting:

Reference value connection is basically carried out via the reference terminals +S and -S (differential input). In this case, a voltage of +10 V at +S corresponds to maximum speed with a reference point of 0V at -S.

It is, however, also possible to preset the reference via a reference potentiometer.

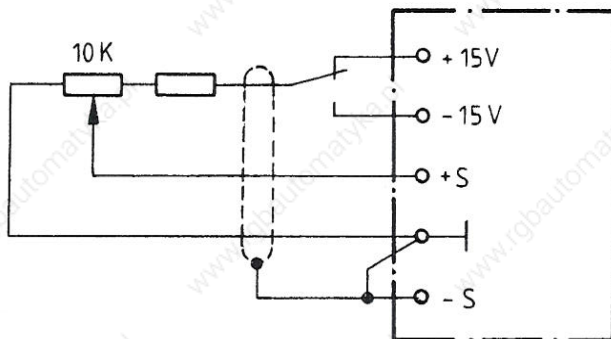

Fig. 1.4/1 Reference presetting with potentiometer

The external bridge connecting -S with 0V  $\perp$  (ELECTRONICS COMMON/GND) can also be implemented internally by installing a jumper on mounting place W13.

**Attention: Reference values must always be shielded! Connect shield to 0V (EARTH)!**

## 1.5 Calculation of tach feedback adaptation

For speed feedback adaptation, the following input circuit is taken as a basis:

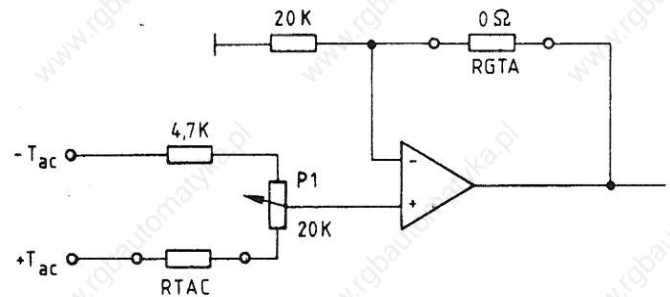

Fig. 1.5/1 Speed feedback adaptation

As a standard, resistance RTAC = 8.2 kilohms is rated at a value that permits the motor to reach a maximum speed of 3000  $\text{min}^{-1}$  with a tach constant of 6 V/1000  $\text{min}^{-1}$ .

For most of the series R extended-rotor motors it is thus not necessary to perform speed feedback adaptation. For all other cases, resistance RTAC can be taken from the Table "Drive packages" given at the end of these Operating Instructions, or calculated by using the following formula:

$$RTAC = \frac{247 - 10 \cdot U_T}{U_T - 10} \quad \begin{array}{l} U_T = \text{max. tach voltage in Volts} \\ RTAC \text{ in kilohms} \end{array}$$

Example: 6 V/1000 - tach voltage

$$n = 2000 \text{ min}^{-1}$$

$$U_T = 6 \text{ V/1000} \cdot 2000 = 12 \text{ V}$$

The a.m. formula, however, only applies for **maximum tach voltages above 10 V to 24 V**.

**For maximum tach voltages above 24 V** the pot P1 has to be adjusted to minimum value; resistance RTAC is calculated in this case as follows:

$$RTAC = \frac{250}{(EMF_{Tach} \cdot n_{max}) - 10} \quad \begin{array}{l} RTAC \text{ in kilohms} \\ EMF_{Tach} \text{ in Volts/1000 min}^{-1} \\ n_{max} \text{ in min}^{-1} \end{array}$$

In some cases ( $U_T < 10 \text{ V}$ ), it is necessary to amplify this tach voltage via resistance RGTA (also see chapter 11).

Resistance RGTA is calculated in this case as follows:

$$RGTA = 20 \cdot GTA - 20 \quad \begin{array}{l} GTA = \text{desired amplification factor} \\ RGTA \text{ in kilohms} \end{array}$$

Example:  $U_{TMAX} = 4 \text{ V}$

$$GTA = \frac{10 \text{ V}}{4 \text{ V}} = 2.5$$

For calculation of RTAC the following applies in this case - under consideration of the amplification factor:

$$RTAC = \frac{247 - 10 \cdot U_T \cdot GTA}{U_T \cdot GTA - 10} \quad \begin{array}{l} U_T = \text{max. tach volt. in Volts} \\ GTA = \text{amplification factor} \\ RTAC \text{ in kilohms} \end{array}$$

## 2. Parametrization and display board 05 SM....

### Explanations

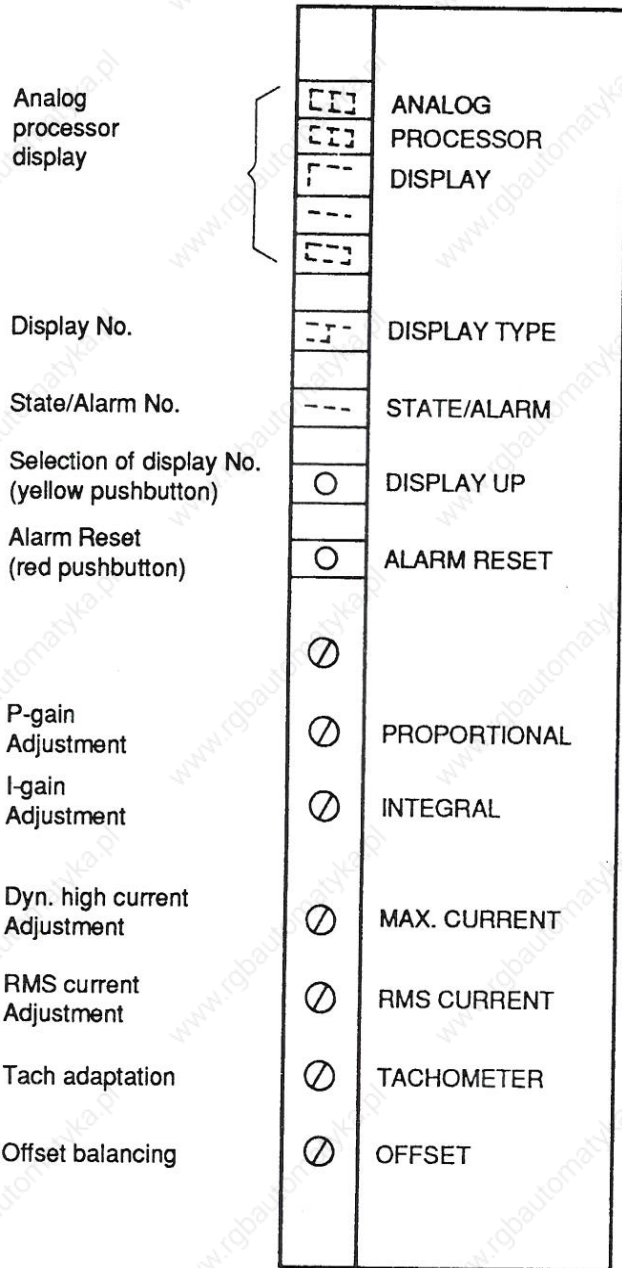

Through repeated pressing of the yellow momentary-contact pushbutton the desired display number is selected.

For fault acknowledgement, also refer to chapter 9

Potentiometer P13 for offset voltage balancing of P-component of n-regulator. Normally, no adjustment required.

Adjustment becomes visible, if display No. (DISPLAY TYPE) 1 is selected.

Adjustment becomes visible, if display No. (DISPLAY TYPE) 2 is selected.

Reduction of dyn. high current; adjustment becomes visible through display No. (Type) 4.

Adjustment becomes visible through display No. (DISPLAY TYPE) 5.

Adjustment becomes visible through display No. (DISPLAY TYPE) 8.

Potentiometer for offset voltage balancing of I-component of n-regulator. (Balancing potentiometer for n-regulator)

Bild 2./1 Parametrization and display board 05 SM..



## 2.1 Handling of parametrization and display board

Upon connection of the mains voltage, a flashing "1" appears in the STATE/ALARM display field - if contact for output stage blocking is open -, while the display unit is still dark.

- The yellow pushbutton for display selection (DISPLAY UP) can now be used for activating the display unit.
- Pressing of the pushbutton effects change-over to the next parameter.

Explanations referring to the parametrization and display unit:

Display No. (DISPLAY TYPE)	Parameter	Adjustment from to	Basic value	Remarks
1	P-gain	110 - 9950	1000	Adjustment depends on application; adjustable via pot. P4 (PROPORTIONAL)
2	I-gain	110 - 9950	1000	Adjustment depends on application; adjustable via pot. P5 (INTEGRAL)
3	D-component	110 - 500	0000	Uneffective on standard unit; activation through R <sub>dif</sub> . It is advisable to consult service department!
4	Dyn. high current	0 A - I <sub>MAX</sub> (A)	I <sub>MAX</sub>	Example: 05 SM 8022: 05.00 = 5.0 A = I <sub>MAX</sub> , reduction possible via pot. P2 MAX. CURRENT (dyn. high current adjustment)
5	RMS current	0.2 I <sub>RMS</sub> - I <sub>RMS</sub> (A)	I <sub>RMS</sub>	Reduction possible via pot. P3 RMS CURRENT (RMS current adjustment)
6	Current feedback	Display only (A)	-	Accuracy: ±5 %
7	Average current	Display only (A)	-	Accuracy: ±5 %
8	Tach voltage	Display only (V)	-	True tach voltage
9	Reference voltage	Display only (V)	-	10 V = n <sub>max</sub>

## 2.2 Display function "Master/Slave"

If a subrack is equipped with several 05 SM.... speed regulators, the display of all speed regulators can be called through actuation of just one display selection pushbutton (yellow pushbutton, DISPLAY UP). This so-called master/slave function is implemented by using jumper W19 as follows:

Master servo amplifier	W19	1-2
Slave servo amplifier	W19	2-3



### 3. Initial motor start-up

For this purpose, speed control with tach feedback has been chosen as standard mode of operation. For other modes of operation refer to the following chapters.

#### 3.1 Checks and adjustments on the disconnected unit

- Provide EMERGENCY SHUTDOWN equipment.
- Observe travelling range; if required, decouple motor mechanically (if possible).
- Turn potentiometers P2 (MAX. CURRENT) for  $I_{MAX}$  provided on the speed regulators as far as the left-hand stop to reduce the dyn. high current.
- Check whether a "1" is present in the display field "STATE/ALARM". If other numbers appear, consult the chapter dealing with the fault and state signals.
- Adjust P-gain to a prespecified value or to a freely selectable value up to 1000 with the aid of the displayed parameter (DISPLAY TYPE) No. 1 and pot. P4 PROPORTIONAL.
- Adjust I-gain to a prespecified value or to a freely selectable value up to 500 with the aid of the displayed parameter (DISPLAY TYPE) No. 2 and pot. P5 INTEGRAL.

#### 3.2 Application of motor voltage

- Put speed regulator into operation, i.e. release output stage blocking and check, whether a "0" is present in the display field "STATE/ALARM".
- Preset a voltage reference value of about 1 V at the speed regulator. Check by using parameter (DISPLAY TYPE) No. 9.
- Turn potentiometer "P2 MAX. CURRENT" slowly in clockwise direction until the motor starts rotating.
- If a "4" is indicated in the display field STATE/ALARM, change tach polarity or adjust tach monitoring function as described in chapter 3.2.1. At proper tach polarity, the tach monitoring function can be rendered ineffective by removing jumper W5.

##### 3.2.1 Adjustment of tach monitoring function

- Install jumper W1 in position 2-3 (armature voltage control)
- Turn potentiometers P10 and P11 as far as the left-hand stop.
- Switch unit on and preset the speed reference defined for a specific speed, e.g. 3.3 V at  $1000 \text{ min}^{-1}$ . Basically, a value of 10 V corresponds to  $3000 \text{ min}^{-1}$ . This reference can be read on the display unit by using parameter (DISPLAY TYPE) No. 9.

- Select parameter (DISPLAY TYPE) No. 8 and use potentiometer P11 for adjusting a speed feedback corresponding to  $1000 \text{ min}^{-1}$ . For tachogenerators TB206, TB306, TB406 or FC12T, this value is 6 V.
- Turn potentiometer P10 slowly in clockwise direction (up to the limit for over-compensation). Following this, turn it somewhat back again.
- Switch unit off; install jumper W1 in position 1-2 (tach control).
- Should this adjustment not be possible, calculate matching resistor for adaptation RRI anew as described in chapter 3.9, solder it in and repeat adjustment.

#### 3.3 Adjustment of current (important!)

- Select display No. (DISPLAY TYPE) 4 and adjust dyn. high current  $I_{MAX}$  in accordance with the Table "Drive packages" (given in chapter 11) by using the potentiometer P2 for "Adjustment of MAX. CURRENT".
- Select display No. (DISPLAY TYPE) 5 and adjust the RMS current by using potentiometer P3 for "Adjustment of RMS CURRENT".

#### 3.4 Adjustment of maximum speed

Adjust speed in a way that a reference of 10 V provides maximum speed.

#### 3.5 Offset voltage balancing

- Switch unit off.
- Disconnect speed reference from unit.
- Bridge inputs with ELECTRONICS COMMON/GND or install jumper W12.
- Switch unit on.
- Release speed regulator.
- Slow motor down to zero speed by using the offset balancing potentiometer P7 OFFSET.  
**Attention: Long time constant.**
- Switch unit off and reconnect references or open jumper W12.
- If required, perform offset balancing in the superordinated position control circuit.

### 3.6 Speed regulator optimization

- Reconnect motor, if still mechanically decoupled.
- Turn "P-gain" potentiometer P4 PROPORTIONAL in clockwise direction to minimum setting.
- Switch off I-component of speed regulator, apply 24 V to terminal ID OFF.
- Switch drive on.
- Release output stage blocking.
- Preset jump function at half the rated speed and check, whether the speed regulator (n-regulator) hunts. If this is not the case, repeat procedure with a higher resistance until the speed regulator (n-regulator) starts hunting. When doing so, observe speed transient response by using an oscilloscope.

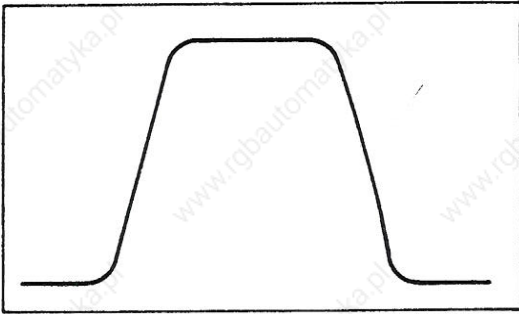

Fig. 3.6/1 Speed curve at properly adjusted P-gain after a jump from  $0 \rightarrow n_{max} \rightarrow 0$

- Activate output stage blocking.
- Choose resistor of about half of the resistance determined.
- Disconnect +15 V or +24 V from terminal ID OFF.
- Turn "I-gain" potentiometer P5 INTEGRAL in clockwise direction to maximum setting.
- Release output stage blocking.
- Preset single reference jump function and observe time response (rapid acceleration to the reference speed with slight overshooting).
- Reduce the value and determine optimum curve (repeat presetting of single reference jump several times, see Figs. 3.6/1 and 3.6/2).

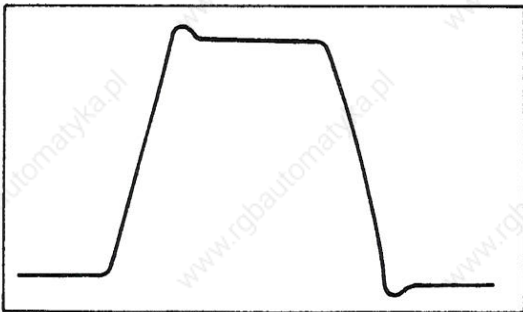

Fig. 3.6/2 Speed curve at properly adjusted P- und I-gain after a jump from  $0 \rightarrow n_{max} \rightarrow 0$

#### 3.6.1 Speed control with P-component only

It is generally possible to perform speed control with the P-component only. To this end, terminal ID OFF must be connected with +24 V. In the case of isolated presetting of the switch-off signal ID OFF (+24 V), it must be ensured that jumpers W17 and W18 are removed from position 1-2 (internal ELECTRONICS COMMON/GND) and plugged onto position 2-3 (isolated 0V reference potential 024 V). In this case, the same optimization criteria apply as for a P-I regulator. It should by all means be avoided that the speed regulator is adjusted to a value at which it starts hunting.

#### 3.6.2 Internal presetting of zero speed reference

For check and trial runs, it is possible to preset zero speed reference internally. For doing so, jumper W12 must be plugged on position 1-2. In this case, the motor is still capable of producing a torque at  $n = 0$ .



### 3.7 Current limitations

The current reference provided by the speed regulator can be limited as follows:

1. Through application of an external limitation voltage
2. Through adjustment of the motor high current
3. Through adjustment of the rated motor current (RMS current)
4. Through increase of the ambient temperature
5. Through speed-dependent current reduction (option)

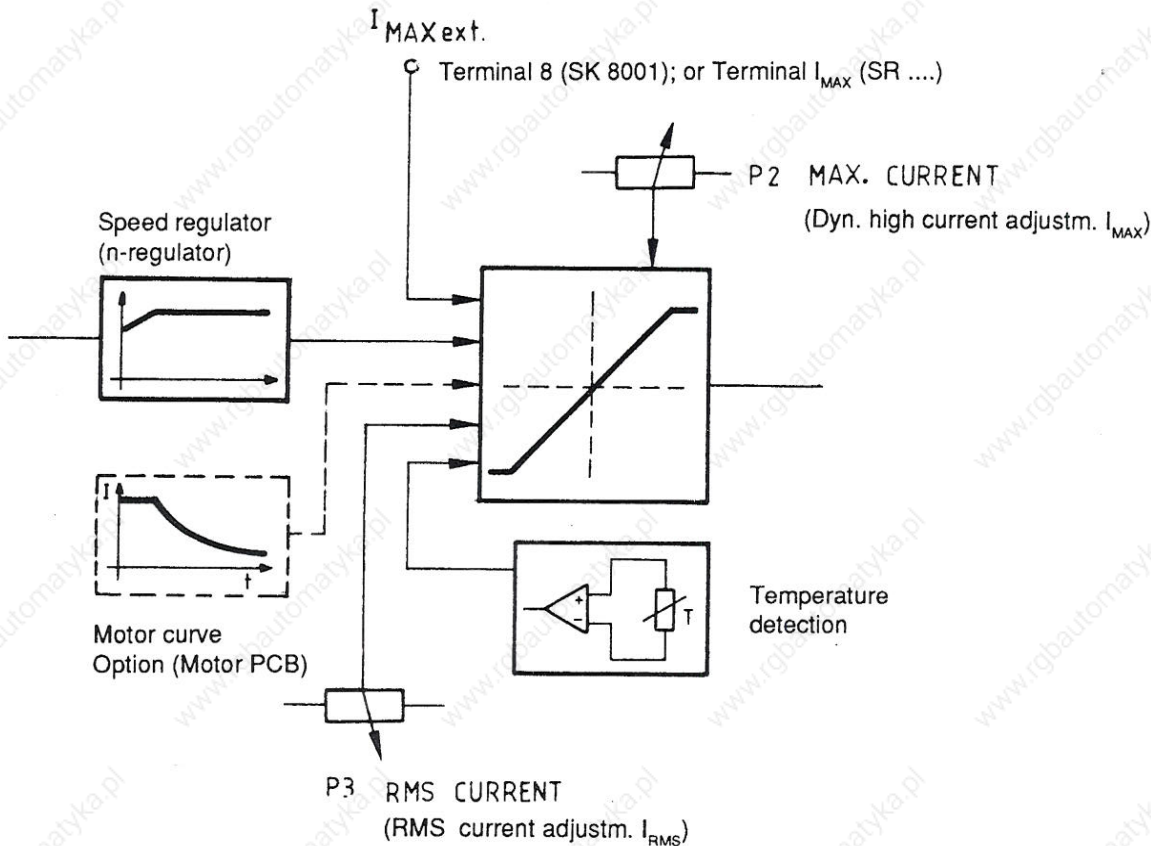

Fig. 3.7/1 Block diagram - Current reference limitation

#### 3.7.1 Limitation through external reference

The speed regulators are provided - at terminal  $I_{MAX}$  - with an analog reference input for dyn. high current limitation. This reference ranges from +10 V to 0V. Reduction of dynamic high current of unit  $I_{MAX}$  is linear between  $I_{MAX}$  and  $0.03 I_{MAX}$ .

Example: 05 SM 8022-75

$$\begin{aligned} I_{RMS} &= 2 \text{ A} \\ I_{MAX} &= 5 \text{ A} \end{aligned}$$

10 V Current limiting voltage	= 5 A
4 V Current limiting voltage	= 2 A = $I_{RMS}$
1 V Current limiting voltage	= 0.5 A

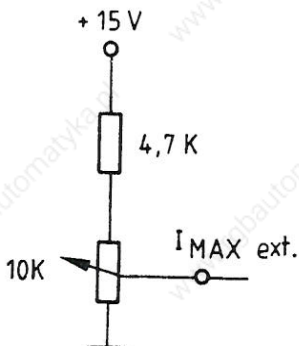

Fig. 3.7/2 Presetting of the external current limitation voltage

#### 3.7.2 Adjustment of motor high current

Potentiometer P2 "MAX. CURRENT" for adjustment of dyn. high current can be used for adjusting the speed regulator to the permissible dyn. motor high current (for motor high current refer to the Table "Drive packages" given in chapter 11), with the setting being displayed by using parameter (DISPLAY TYPE) No. 4.



### 3.7.3 Adjustment of rated motor current

This limitation function is provided to protect the motor against excessive heating. Potentiometer P3 "RMS CURRENT" serves for adjusting the speed regulator to the motor RMS current  $I_{RMS}$  (for rated motor current refer to chapter 11), with the setting being displayed by using parameter (DISPLAY TYPE) No. 5.

### 3.7.4 Limitation through increased ambient temperature > 45°C

At ambient temperatures > 45°C, the high current is reduced by about 4 %/K.

### 3.7.5 Speed-dependent current reduction (Option)

The motor current can be reduced as a function of speed (taper current limit) by plugging on a motor PCB.

This motor PCB is not required for all types of printed-circuit "pancake" and extended-rotor motors (series R..., UGT MEM), provided that the speed listed in the Table "Drive packages" in chapter 11 is not exceeded.

For applications featuring a motor PCB it is necessary to consult the service or product marketing department.

### 3.7.6 Circuit monitoring the "Operating time at RMS current"

The series 05 SM.... speed regulators operate at the adjusted RMS current limit (parameter/DISPLAY TYPE No. 5) only for a limited period of time, which is indicated by a "2" in the STATE display field. The preset operating time at RMS current can be adjusted - with the aid of resistor RAL 3 - between a value of 0 s and one of infinite order (factory-adjusted value by ABB: about 10 s). After elapse of this operating time, ALARM No. 3 appears. This alarm can be programmed as follows by using jumper W11:

- |     |           |   |
|-----|-----------|---|
| W11 | Open      | No observable reaction of drive; only display.                                |
| W11 | Pos.. 1-2 | Internal output stage blocking; "Ready for operation" relay drops out.        |
| W11 | Pos.. 2-3 | Internal speed reference zero; "Ready for operation" relay does not drop out. |

Calcul. of RAL 3:  $RAL\ 3 = (e^{0.1t} - 1) \cdot 10$       RAL 3 in Ohms  
t in s

## 3.8 Current control

The current limiter output is used as current reference. The output of the motor circuit is taken as feedback. The difference between reference and feedback represents the control deviation.

**Important: Parameters P and I of the current regulator can not be adjusted by the user.**

For series 05 SM regulators, the mode of operation can be changed over from speed to current control. For doing so, jumper W4 must be plugged onto position 1-2.

10 V reference at +S1 and -S1 then corresponds to  $I_{MAX}$ .

Example: 05 SM 8022-75  $I_{RMS} = 2\ A$ ,  $I_{MAX} = 5\ A$ ,  $10\ V = 5\ A$

## 3.9 Armature voltage control with I · R-compensation

In standard design, the series 05 SM.... speed regulators are provided with a mode of operation "tach feedback". If they are to be operated with armature voltage feedback, jumper W1 must be removed from position 1-2 and plugged onto position 2-3 before.

### Function:

In the case of armature voltage control, first the armature voltage is fed back internally at terminals +M and -M. The ohmic voltage drop of the armature winding is compensated via an adaptation circuit ( $R \cdot I$  compensation), since this component does not contribute to speed.

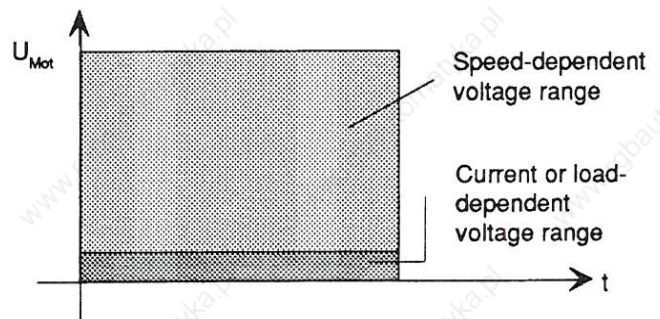

Fig. 3.9/1 Voltage ranges for armature voltage control



### Calculation of the adaptation circuit:

$$RRI = \frac{K_{SERVO}}{R_{int}}$$

$RRI$  = Resistance for adapt. in kilohms  
 $K_{SERVO}$  = Correction factor (see below)  
 $R_{int}$  = Internal resistance of motor and incoming supply line in Ohms

For  $R_{int}$ , please refer to the motor data sheets.

Correction factor  $K_{SERVO}$ :

05 SM8022-75:	144
05 SM8042-75:	72
05 SM8062-75:	48
05 SM8122-75:	24
05 SM8062-95:	100
05 SM8122-95:	50

Example: Calculation for motor type RS 420 connected to 05 SM 8122-95

$R_{int} = 0.8$  Ohms (given in data sheets on small-power DC motors with extended rotor, series RE, RS, RX, publication No. D EA 5276 90 D)

$$RRI = \frac{K_{SERVO}}{R_{int}} = \frac{50}{0.8} = 62.5 \text{ kilohms}$$

Next standard value:  $RRI = 56$  kilohms

### Balancing of armature voltage control

- Solder in resistor RRI.
- Switch unit on and preset a defined speed reference, e.g. 3.3 V for 1000 min<sup>-1</sup>. Normally, a value of 10 V corresponds to about 3000 min<sup>-1</sup>. Read this reference value from the display by using parameter (DISPLAY TYPE) No. 9.
- Use potentiometer P11 for adjusting the speed to 1000 min<sup>-1</sup> (check adjustment of motors without tach by using a tachometer).
- Turn potentiometer P10 slowly in clockwise direction (up to the limit for over-compensation). Following this, turn it somewhat back again.

## 3.10 External output stage blocking (Stand by)

The input "External output stage blocking" (Stand by) provided at terminal SBY (4) serves for releasing and blocking the speed regulators. For the standard versions (as delivered by ABB), the speed regulators are adjusted (jumper W9 on 1-2) in a way that they are blocked with the terminal unconnected or connected to +15 V and released when a voltage of 0V is applied. It is possible to invert this function by installing jumper W9 on position 2-3.

If the speed regulator is blocked, the "Ready for operation" relay drops out (standard function, as delivered by ABB). If this relay is to be used as mere common fault signalling relay (response to alarm signals only), jumper W30 must be removed from pos.1-2 and plugged onto pos. 2-3 (from hardware status 05 SM...3-..).

### 3.10.1 Delayed output stage blocking

From hardware status 05 SM...3-.., it is possible to block the speed regulators with delay. In this case, the speed reference is switched internally - without delay - to 0V and the output stage is blocked with a delay of 1 s (value adjusted by ABB). This will cause active deceleration of the drive. To this end, jumper W31 must be removed from position 1-2 and plugged onto position 2-3. As delivered by ABB (jumper W31 on position 1-2), the speed regulator is blocked without any delay and the drive coasts to rest.

The active deceleration time can be reduced via resistor RSBY.

$$RSBY = 270 \text{ kilohms} \quad \approx 1 \text{ s delay time (value adjusted by ABB)}$$

$$RSBY = 27 \text{ kilohms} \quad \approx 0.1 \text{ s delay time}$$

### 3.10.2 External output stage blocking via opto-isolated 24 V inputs

With the series 05 SM... speed regulators it is possible to inject the signal "Output stage blocking" (SBY) as isolated signal via optocouplers (provided in the unit). To this end, jumpers W17 and W18 must be removed from position 1-2 (internal ELECTRONICS COMMON/GND) and plugged onto position 2-3 (isolated 0V reference potential 024 V).

Jumper W9 on standard position 1-2:

In this case, the speed regulator is released, if a voltage of 24 V is applied to SBY (terminal 4), with 0V reference potential to 024 V (terminal 5).

The speed regulator is blocked, if an external 0V signal is applied or if the contact is open.

Jumper W9 on position 2-3:

If jumper W9 is installed on position 2-3, the function at terminal SBY is inverted again.

## 3.11 Limit switch functions

The speed regulators are provided with two limit switch inputs E1, E2, which can be adjusted - with the aid of jumpers W10, W22 and W23 - as follows:

- |                  |  |
|------------------|--|
| W10 open:        | Limit switch input 1 or 2 provides a zero speed reference for one direction.                               |
| W10 2-3:         | Limit switch input 1 or 2 provides a zero speed reference for both directions.                             |
| W10 1-2:         | Limit switch input 1 or 2 initiates blocking of the speed regulator.                                       |
| W22 and W23 2-3: | The limit switches are activated, if their inputs are connected to +24 V (active).                         |
| W22 and W23 1-2: | The limit switches are activated, if their inputs are connected to 0V reference potential 024 V (passive). |

## 4. Instructions referring to operation of unit connected to a superordinated control system

- Connect unit for operation with a superordinated control system.
- Connect reference to differential reference input +S.
- Connect reference potential 0 V to differential reference input -S.
- Perform speed balancing.

Operate unit at maximum speed while measuring the reference voltage. If required, correct adjustment by means of speed feedback potentiometer P1 TACHOMETER (tach adaptation).

- Check positioning behaviour. If the results are not satisfactory, change factor  $K_v$  (closed-loop gain) of the control system.
- If required, modify speed regulator circuitry, e.g. P-circuit.



## 5.2 Functions of terminals of subrack 05 SR....

No.	Designation	Function
These terminations are common to all axis.		
R1	Input	Supply voltage I from three-phase transformer $U_{\text{secl}} = \text{max. } 120 \text{ V AC}$
S1	Input	Supply voltage I from three-phase transformer $U_{\text{secl}} = \text{max. } 120 \text{ V AC}$
T1	Input	Supply voltage I from three-phase transformer $U_{\text{secl}} = \text{max. } 120 \text{ V AC}$
① R2	Input	Supply voltage II from three-phase transformer $U_{\text{seclI}} = \text{max. } 120 \text{ V AC}$
① S2	Input	Supply voltage II from three-phase transformer $U_{\text{seclI}} = \text{max. } 120 \text{ V AC}$
① T2	Input	Supply voltage II from three-phase transformer $U_{\text{seclI}} = \text{max. } 120 \text{ V AC}$
EARTH	Input	Earth potential terminal for subrack
FAN	Input	Fan supply voltage 220 V; 0.1 A for each fan ②
FAN	Input	Neutral conductor for 220 V

① Depending on the application, it may be possible to provide a second input from a second secondary transformer winding.

② These terminations are only provided in cases where subracks equipped with fans are used. Current consumption per fan must be multiplied by the number of fans involved.

### 5.2.1 Functions of terminals provided for each axis

No.	Designation	Function
+M	Output	Positive connection of motor; if required, via a smoothing choke, also refer to chapter 11
-M	Output	Negative connection of motor
EARTH	Input	Earth potential for shield connection
+15 V	Output	Positive voltage of electronics supply, load capacity max. 20 mA
GND	Output	ELECTRONICS COMMON/GND
-15 V	Output	Negative voltage of electronics supply, load capacity max. 20 mA
$I_{\text{MAX}}$	Input	External current reduction $+10 \text{ V} = I_{\text{MAX}}$ , also refer to chapter 3.7.1
ID OFF	Input	Switching off of I-(D-) component of n-regulator, also refer to chapter 3.6.1
+S2	Output	Speed reference signal after limitation, e.g. through limit switch
-S2	Not used	
EARTH		
E1	Input	Limit switch input for zero speed presetting for one direction, also refer to chapter 3.10
E2	Input	Limit switch input for zero speed presetting for one direction, also refer to chapter 3.10
+S1	Input	Positive connection of differential input
EARTH	Input	Earth potential for shield connection of reference
-S1	Input	Negative connection of differential input
+T	Input	Positive connection of tacho-generator
EARTH	Input	Earth potential for shield connection of speed feedback
-T	Input	Negative connection of tacho-generator
0 24	Input	0V ref. potential for terminals ID OFF, E1, E2 and - if external 24 V are applied - SBY
SBY	Input	External output stage blocking, also refer to chapter 3.9
RDY1	Output	Relay indicating "Ready for operation", contact rating 125 V, 0.5 A, 10 VA
RDY2	Output	Relay indicating "Ready for operation", contact rating 125 V, 0.5 A, 10 VA

### 5.3 Functions of terminals of supply transformer DTK....

Designation		Function
U 1	Input	Primary voltage 380 V AC, other primary voltages possible
V 1	Input	Primary voltage 380 V AC, other primary voltages possible
W 1	Input	Primary voltage 380 V AC, other primary voltages possible
U 2	Output	Secondary voltage 30 V AC or 50 V AC or 65 V AC or 75 V AC or 100 V AC or 120 V AC ①
V 2	Output	Secondary voltage 30 V AC or 50 V AC or 65 V AC or 75 V AC or 100 V AC or 120 V AC ①
W 2	Output	Secondary voltage 30 V AC or 50 V AC or 65 V AC or 75 V AC or 100 V AC or 120 V AC ①
PE	Input	PE terminal

① Connection to terminals R, S, T on subrack or card holder

### 5.4 Functions of terminals of smoothing choke GD...

Designation		Function
1.1 1.2		Increase of external armature circuit inductance, for allocation refer to chapter 11

## 6. Measuring points, jumpers

### 6.1 Measuring points

Measuring point	Function	Measured value max.	Corresponding to	0V reference potential to
+S1	Speed reference ②	±10 V		-S1 ①
-Tach	Speed feedback ②	Max. tach voltage		+Tach or GND 0V
+S2 S MON	Speed reference after limitation, e.g. through limit switch	±10 V		GND 0V
I MON		Current feedback ②	+10 V	±I <sub>MAX</sub>
I AVG	Average current ② feedback during the past 30 s	+10 V + 4 V	±I <sub>MAX</sub> ±I <sub>RMS</sub>	GND 0V GND 0V
U MOT	Motor voltage depending on RTAC	+10 V	Max. motor voltage	GND 0V

① If a jumper is installed on position W13, 0V reference potential is to GND 0V.

② Also indicated on the display unit.

### 6.2 Jumpers

No.	Function	Standard configuration	Standard position of jumpers (as delivered by ABB)	Explanation in chapter
W1	Tach/armature voltage feedback	Tach feedback	1-2	3.9
W4	Speed/current control	Speed control	2-3	3.8
W5	Tach monitoring effective/ineffective	Effective	Jumper installed	
W9	Activated regulator blocking	Internal 0V ref. potential	1-2	3.10
W10	Operation of limit switches	One direction	Open	3.11
W11	Operating time at rated current	Uneffective	Open	3.7.6
W12	Zero speed reference presetting	Uneffective	Open	3.6.2
W13	Reference input differential or not	Differential	Open	1.2.1
W17	0V reference for regulator blocking	Internal 0V	1-2	3.10.1
W18		GND	1-2	
W19	Master/Slave display	Slave	2-3	2.2
W22	Active or passive limit switches	Active	2-3	3.11
W23			2-3	
W24	Earth-fault monitoring	Uneffective	1-2	
W30	Change-over of the relay indicating "Ready for operat." to common fault signal. only	Relay drops out also at output stage blocking	1-2	3.10
W31	Delay of external output stage blocking	Undelayed	1-2	3.10.1



## 7. Fusing

### 7.1 Internal fusing of 05 SM

#### Power section fuse F1

05 SM 8022-75: } F1 = 8 A T (slow) /250 V  
 05 SM 8042-75: } 6 x 32 mm

05 SM 8062-75, 05 SM 8062-95: } F1 = 25 A T (slow) /250 V  
 05 SM 8122-75, 05 SM 8122-95: } 6 x 32 mm

#### Electronics section fuse F2

05 SM 8022-75: }  
 05 SM 8042-75: } F2 = 2.5 A T (slow)/250 V  
 05 SM 8062-75: } 5 x 20 mm  
 05 SM 8122-75: }

05 SM 8062-95: } F2 = 1 A T (slow) /250 V  
 05 SM 8122-95: } 5 x 20 mm

### 7.2 External fusing

The external transformer T1 supplying the subrack or card holder must be fused on the primary side.

The primary transformer current  $I_{\text{prim}}$  can be calculated as follows:

$$I_{\text{prim}} = \frac{P}{U \cdot \sqrt{3}}$$

P = transformer rating (VA)  
 U = phase voltage  
 e.g. 380 V

3 slow fuses with standard ratings corresponding to the primary current have to be used.

### 7.3 Fusing of braking modules 05 SB....

	F1 6 x 32 mm	F2 6 x 32 mm	F3 5 x 20 mm
05 SB 8111	-	-	2.5 A T (slow) /250 V
05 SB 8211	-	32 A T (slow) /150 V	1 A T (slow) /250 V
05 SB 8411	32 A T (slow) /150 V	32 A T (slow) /150 V	1 A T (slow) /250 V

## 8. Start-up of braking modules

### 8.1 Start-up of braking modules 05 SB8111 (single-axis applications)

The 05 SB8111 braking module can only be used for single-axis applications and only with regulator cards 05 SM8062-95 and 05 SM8122-95. It is electrically connected and firmly mounted at the regulator rear by means of four spacers.

#### Function

The braking module monitors the supply voltage. It switches on as soon as the DC link voltage exceeds the upper threshold value and switches off when the lower threshold value is reached. If the braking power (about 40 W) is exceeded or if the braking module is defective, alarm indication (ALARM) No. 7 becomes effective for series 05 SM.... speed regulators. The maximum non-repetitive dynamic braking energy available is 200 Ws.

Mounting by means of 4 • (2 • M3 screws and two spacers)

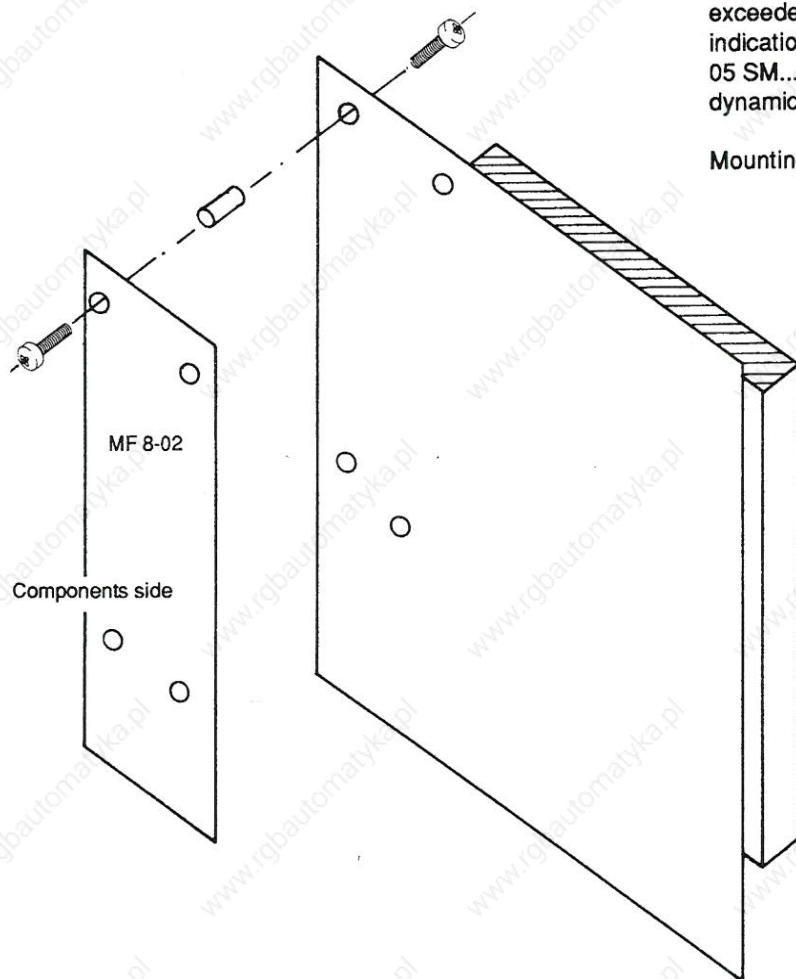

Fig. 8.1/1 Arrangement drawing for 05 SB8111

## 8.2 Start-up of braking modules 05 SB8211 and 05 SB8411 (only for 05 SR.... subracks)

The braking modules 05 SB8211 and 05 SB8411 serve for converting the braking energy produced during regenerative operation of drives into heat. In addition to the braking functions, the braking modules 05 SB8211 and 05 SB8411 are provided with functions for checking the supply voltage and detection of earth-faults.

Two different module types are available:

1. Module 05 SB8211 for control of one ballast resistor, with a thermal power loss of 200 W.
2. Module 05 SB8411 for control of two ballast resistors by using two different control methods.

### 1st method (jumper J1 on position 2-3)

2 ballast resistors are connected to **one** DC link and are controlled by **one** control circuit. Thermal power loss of both ballast resistors amounts to 400 W.

### 2nd method (jumper J1 on position 1-2)

2 ballast resistors are connected to **two** DC links (in one subrack) and are controlled by **two** control circuits. Thermal power loss is 200 W for **each** ballast resistor and **each** DC link (also see block diagram below).

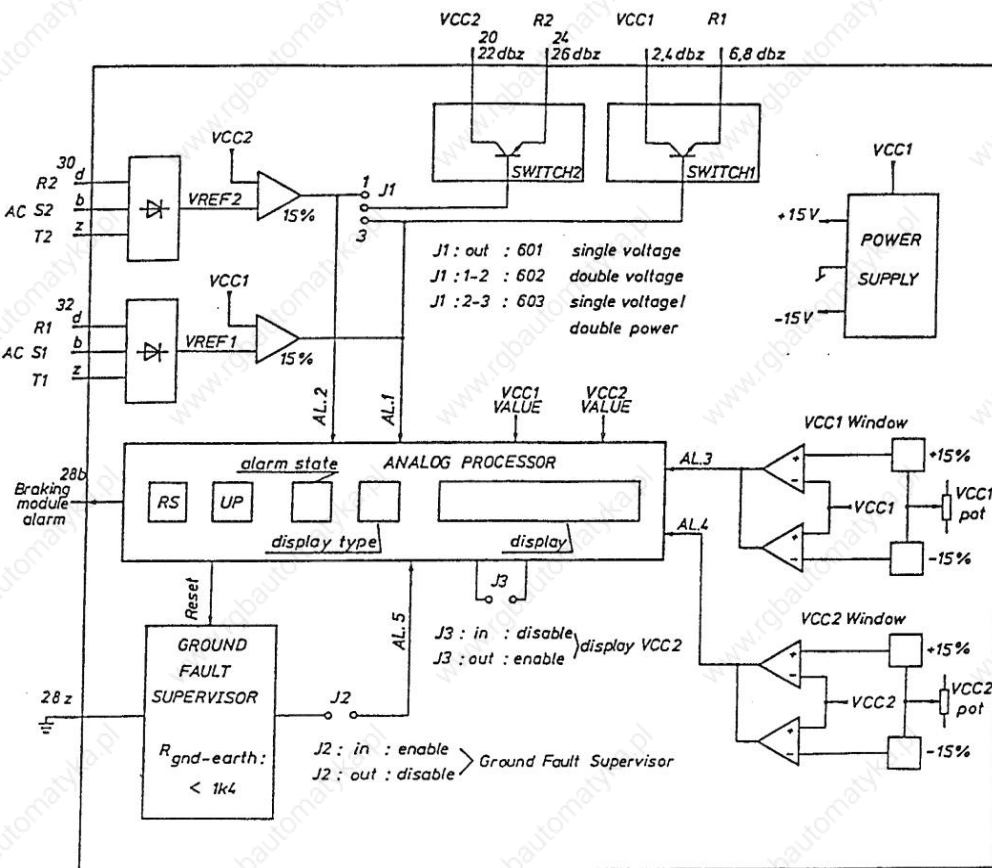

In the case of module 05 SB8211, VCC2, VREF2, SWITCH2 and VCC2 Window are not effective or not fitted.

Fig. 8.2/1 Block diagram for modules 05 SB8211 and 05 SB8411

### 8.2.1 Mode of operation of braking modules

Figure 8.2/1 shows the mode of operation of the braking modules.

First, a mains-dependent reference voltage is derived from the secondary transformer side R1, S1, T1, which is compared with the actual DC link voltage VCC1. As soon as

the DC link voltage has reached a value by 15 % higher than the reference voltage, the power transistor is switched on and converts the surplus energy into heat. At the same time, a "1" appears in the STATE display field indicating active braking. The same applies analogously for subracks provided with 2 DC links.



### 8.2.2 Parametrization and display board for 05 SB8211 and 8411

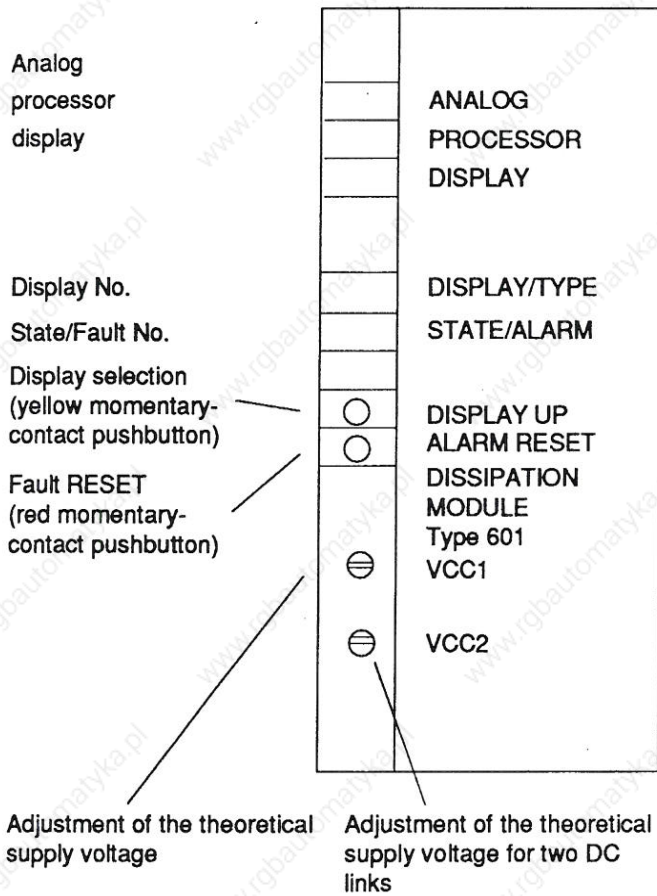

Fig. 8.2/2

Upon connection of the mains voltage - if contact for output stage blocking is open - a "0" is present in the STATE/ALARM display field, while the display unit is still dark.

Now, the yellow display selection button (DISPLAY UP) can be used for activating the display unit. By pressing this button, change-over between the various parameters is effected.

Explanation of parameter numbers (DISPLAY TYPE):

Display No. (DISPLAY TYPE)	Parameter	Adjustment from to	Remark
1	VCC1 theoretical	50 V - 250 V	Theoretical ① supply voltage
2	VCC2 theoretical	50 V - 250 V	Theoretical ① supply voltage of DC link No. 2
3	VCC1 real		Real supply voltage
4	VCC2 real		Real supply voltage of DC link No. 2

① For initial start-up, to be adjusted to the actual DC link voltage by using potentiometer VCC1 and, if required, VCC2.

### 8.2.3 STATE/ALARM display field of braking modules 05 SB8211 and 05 SB8411

The STATE/ALARM display field serves for indicating the following faults/states:

STATE/ALARM	Indication	Type of display
0	Braking module OK	State display (STATE)
1	Braking for VCC1 DC link No. 1	State display (STATE)
2	Braking for VCC2 DC link No. 2	State display (STATE)
3	Violation of tolerances for VCC1, DC link No. 1	Fault display (ALARM)
4	Violation of tolerances for VCC2, DC link No. 2	Fault display (ALARM)
5	Earth-fault	Fault display (ALARM)

If two ALARM signals are initiated at the same time, only one - with the highest number - is indicated. The other ALARM signal remains effective in the background.

ALARM signals 3, 4 and 5 of braking modules SB8211 and SB8411 are transferred to the 05 SM.... regulator cards, where they are indicated through fault (ALARM) indication No. 7. In this case, the SM regulator cards are blocked, the relay drops out.

### 8.2.4 Arrangement of jumpers and fuses on modules 05 SB8211, 05 SB8411

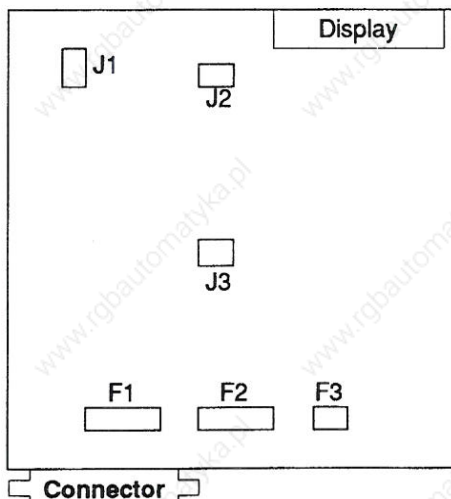

Fig. 8.2/3

## 9. Fault and state signals (STATE/ALARM)

ALARM No.	Indication	Reaction of drive	Fault acknowledgement	Explanation given in chapter
0	Speed regulator OK	Active	State display	
1	Speed regulator blocked Output stage blocking ②	Motor coasts to rest or decelerates	State display	3.10 and 3.10.1
2	RMS current $I_{RMS}$ reached	Motor continues running at rated current (RMS)	State display	3.7.6
3	Maximum operating time at RMS current $I_{RMS}$ elapsed ① (refer to chapter 3.7.6)	Refer to chapter 3.7.6	Reset pushbutton or mains OFF/ON	3.7.6
4	Tacho-generator fault	Motor coasts to rest	Reset pushbutton or mains OFF/ON	3.2 and 3.2.1
5	Overtemperature of speed regulator ①	Motor coasts to rest	Reset pushbutton or mains OFF/ON	
6	Short-circuit or earth-fault ①	Motor coasts to rest	Mains OFF/ON	
7	Braking module alarm and over- or undervoltage ①	Motor coasts to rest	No acknowledgement required. Drive can restart automatically, provided that the relay indicating "Ready for operation" is not wired in the EMERGENCY SHUTDOWN loop.	

① Relay indicating "Ready for operation" drops out.

② For speed regulators with a hardware state from 05 SM...3... it is possible to prevent the relay indicating "Ready for operation" from dropping out by removing jumper W30 from position 1-2 and installing it on position 2-3.

Re ALARM No. 7:

Response threshold at under- or overvoltage

Type of speed regulator	Undervoltage threshold	Overtolerance threshold
05 SM....-75	20 V	125 V
05 SM....-95	45 V	210 V

If the overvoltage alarm is initiated during braking, a braking module has to be installed.



# 10. Diagnosis of drive system faults

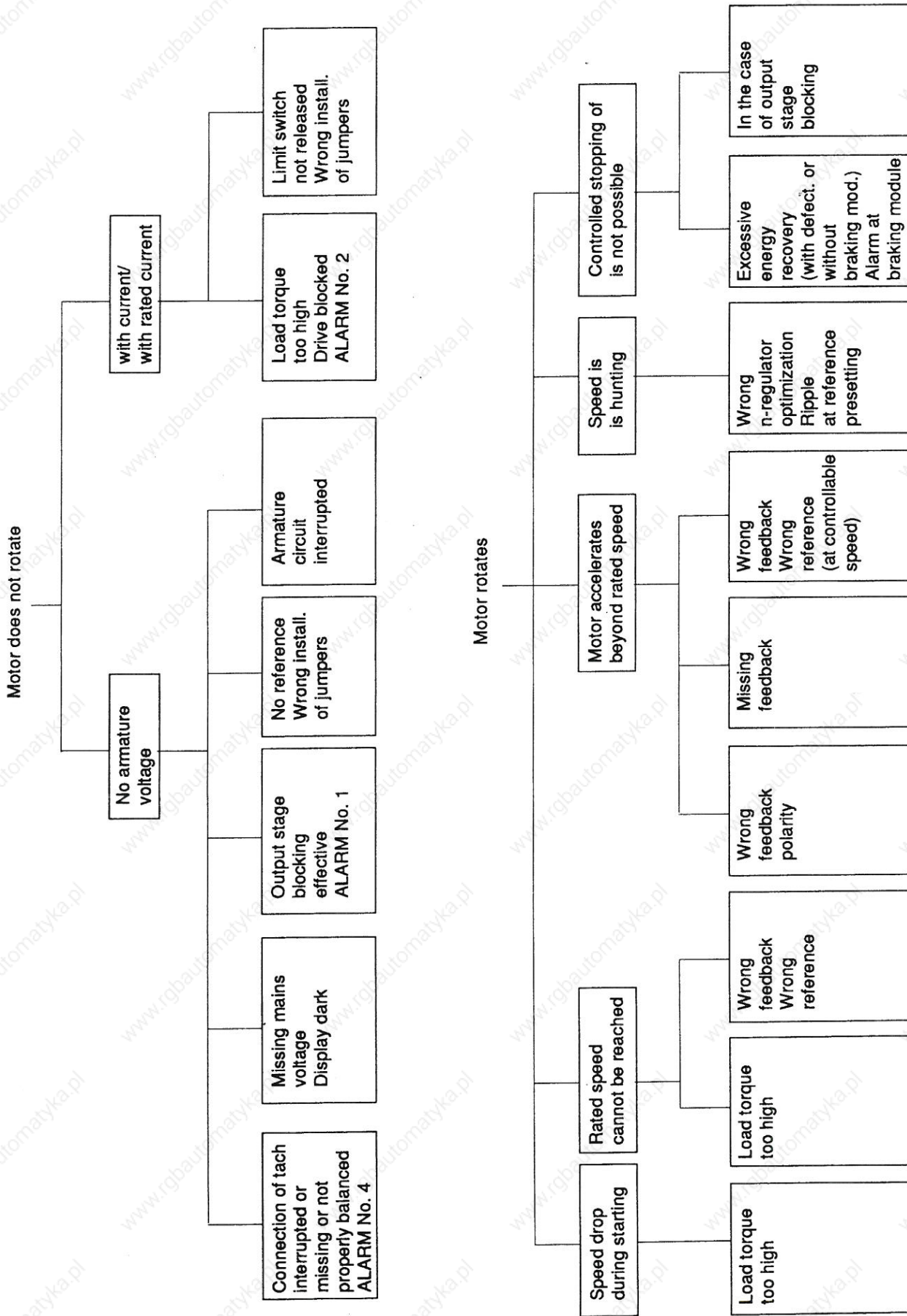

Drive package			Characteristic data								
DC Servo motor (with tach)	+	Speed regulator	Torque	Impulse torque I	Impulse torque II	Rated speed	RMS current	Rated voltage	Dyn. high curr. I	Dyn. high curr. II	Mass moment of inertia
Type		Type	Ncm	Ncm	① Ncm	min <sup>-1</sup>	$I_{RMS}$ A ②	V	$I_{MAX I}$ A ②	$I_{MAX II}$ A ①	kgcm <sup>2</sup>
RT110+TB206 + 05 SM8022-75			6	24	/	3000	1.0	37	3	/	0.19
RT120+TB206 + 05 SM8022-75			12	48	/	3000	1.4	47	4.8	/	0.29
RT130+TB206 + 05 SM8022-75			17	53	/	3000	1.8	48	5	/	0.35
RT140+TB206 + 05 SM8022-75			22	85	/	3000	2.3	46	8	/	0.41
RT220+TB206 + 05 SM8042-75			23	58	117	3000	2.1	49	4.5	9	0.74
RT230+TB206 + 05 SM8042-75			32	80	/	3000	2.9	46	5.6	/	0.89
RT240+TB206 + 05 SM8042-75			41	100	/	3000	3.5	48	7.8	/	1.13
RT320+TB206 + 05 SM8062-75			55	90	171	3000	5.2	46	7.9	15	2.45
RT330+TB206 + 05 SM8062-75			90	100	245	3000	5.8	65	6.1	15	3.45
RE110+TB103 + 05 SM8022-75			5	15	/	3000	1.8	22	4.4	/	0.041
RE120+TB103 + 05 SM8042-75			9.5	18	35	3000	2.8	22	4.5	8.8	0.058
RE130+TB103 + 05 SM8042-75			12.5	22	48	3000	3.0	23	4.6	10	0.075
RE220+TB206 + 05 SM8062-75			24	68	/	3000	4.7	24	12	/	0.245
RE230+TB206 + 05 SM8122-75			33	80	140	3000	6.4	24	14	24.4	0.31
RE240+TB206 + 05 SM8122-75			42	90	165	3000	6.8	27	13.2	24.4	0.375
RE320+TB206 + 05 SM8062-75			50	90	200	3000	4.3	50	6.8	15	0.875
RE330+TB206 + 05 SM8062-75			70	120	207	3000	5.7	50	8.7	15	1.16
RE340+TB206 + 05 SM8122-75			85	150	382	3000	6.2	55	9.8	25	1.45
RX120+TB206 + 05 SM8042-75			30	70	/	3000	3.0	46	6.4	/	0.5
RX130+TB206 + 05 SM8042-75			40	100	/	3000	3.6	47	8.5	/	0.68
RX320+TB206 + 05 SM8122-75			90	180	350	3000	6.8	53	12.4	24.1	5.0
RX330+TB206 + 05 SM8122-75			130	260	/	3000	9.7	52	18.2	/	7.2
RX520+TB306 + 05 SM8122-95			190	400	800	3000	6.0	110	12.7	25	12.8
RX530+TB306 + 05 SM8122-95			290	600	950	3000	9.3	115	19	30	17.4
RX620+TB306 + 05 SM8122-95			400	1200 ④	1450	2700	8	150	24	30	35
RX630+TB306 + 05 SM8122-95			550	1500	-	2700	11	150	30	-	50
RS110+TB103 + 05 SM8022-75			5	15	/	3000	1.7	22	4.1	/	0.056
RS130+TB103 + 05 SM8042-75			12.8	24	50	3000	2.8	23	4.6	9.7	0.073
RS220+TB206 + 05 SM8042-75			22	57	/	3000	4.0	23	9.9	/	0.245
RS230+TB206 + 05 SM8062-75			30	80	/	3000	5.6	23	14	/	0.31
RS240+TB206 + 05 SM8062-75			38	95	/	3000	5.9	26	13.9	/	0.375
RS320+TB206 + 05 SM8062-75			50	90	190	3000	4.4	48	7	15	0.902
RS330+TB206 + 05 SM8062-75			68	120	205	3000	5.4	49	8.8	15	1.16
RS340+TB206 + 05 SM8062-75			82	150	/	3000	6.0	52	10.3	/	1.45
RS420+TB206 + 05 SM8122-95			100	180	450	3000	6.8	60	11.2	28.1	2.3
RS430+TB206 + 05 SM8122-95			140	240	645	3000	7.0	77	11.2	30	3.18
RS440+TB206 + 05 SM8122-95			175	325	770	3000	7.3	90	12.7	30	4.05
RS520+TB306 + 05 SM8122-95			230	550	/	3600	7.7	120	22	/	13.55
RS530+TB306 + 05 SM8122-95			300	700	940	3500	9.5	125	23	30	17
RS540+TB306 + 05 SM8122-95			360	800	1020	3200	10.5	125	24	30	20.5
RS620+TB306 + 05 SM8122-95			400	900	1110	3000	10.8	120	25	30	53
UGT MEM 01SB4 +7S +05 SM8022-75			5.9	7	11.8	3000	2.0	22	2.3	3.8	0.036
UGT MEM 01MB4 +7S +05 SM8022-75			8.8	15	19.6	2500	2.0	25	3.8	4.0	0.042
UGT MEM 01LB4 +7S +05 SM8022-75			9.8	16	23.5	2000	2.0	23.5	3.3	4.5	0.046
UGT MEM 03SB2 +7S +05 SM8042-75			25.5	25.5	47.1	2000	3.8	25	3.8	6.8	0.26
UGT MEM 03MB +7S +05 SM8062-75			39.2	45	72.6	1500	6.0	18.5	6.5	10.9	0.35
UGT MEM 03LB +7S +05 SM8042-75			43.0	75	98.1	1000	4.0	22.5	7.0	8.7	0.39
UGT MEM 06SB2 +7S +05 SM8062-75			43.2	43.2	88.3	1300	5.2	20.5	5.2	10.4	0.97
UGT MEM 06MB2 +7S +05 SM8062-75			65.7	65.7	147.2	1000	5.8	21.5	5.8	12.8	1.07
UGT MEM 06LB4 +7S +05 SM8062-75			98.1	150	242.5	700	6.0	23.5	9.0	15.0	1.79



## Adjustments

Tach feedback 0 $\Delta$ jumper	
RTAC kiloohms	RGTA kiloohms
8.2	0
8.2	0
8.2	0
8.2	0
8.2	0
8.2	0
8.2	0
8.2	0
33	10
33	10
33	10
8.2	0
8.2	0
8.2	0
8.2	0
8.2	0
8.2	0
8.2	0
8.2	0
8.2	0
12	0
12	0
33	10
33	10
8.2	0
8.2	0
8.2	0
8.2	0
8.2	0
8.2	0
8.2	0
8.2	0
2.7	0
2.7	0
5.6	0
8.2	0
3.3 ③	0
10 ③	0
27 ③	0
27	0
15	10
22	22
6.8	22
22	22
18	39

- ① Dyn. high current II/impulse torque II only possible with optional Motor PCB and only up to about 1000 min<sup>-1</sup>. It is advisable to consult the product management/service departments.
- ② By all means adjust or check RMS current  $I_{RMS}$  and dyn. high current  $I_{MAX}$  on 05 SM speed regulator.
- ③ By using DC smoothing choke GD 805
- ④ Only up to a speed of 2200 min<sup>-1</sup>, also refer to the speed/torque diagram in the series R motors catalogue.