

Kollmorgen GOLDLINE™ Brushless Motor Series



Kollmorgen **GOLDLINE** series motors offer the widest range of solutions for servomotor applications. The interior permanent magnet design is the key to achieving high torque and power density while eliminating problems with magnets placed directly on the airgap. This magnetic structure allows low inertia designs making the Kollmorgen **GOLDLINE** series an industry standard for performance in high response, point-to-point move applications.

Additional motion control solutions are available with these options:

- NEMA and metric mounts
- 0.84 to 149 N-m continuous torque
- IP65 & 67 sealing
- Multiple connector options
- Explosion proof designs
- Resolver and encoder feedback
- Gearmotors
- Electromechanical failsafe brakes

When combined with the **SERVOSTAR®** digital amplifier series (using Kollmorgen's patented phase angle advance algorithms), the system performance provides the most peak torque and speed in the industry. All motors and drives are UL recognized.

KOLLMORGEN

B, M-Series

B-Series (Low-Inertia)

The B-Series provides extremely low inertia rotors allowing for optimum performance in applications requiring rapid acceleration and deceleration.

M-Series (Medium-Inertia)

The M-Series is an extension of the B-Series. With seven times higher inertia, this motor series offers the advantage of better performance for systems having compliant loads or larger inertia mismatches.

- 0.84 to 149 N-m (0.62 to 110.0 lb-ft)
- 70.0 to 190.0 mm (2.76 to 7.48 inches) Square Frame
- Resolver Feedback
- Maximum Recommended Speed 7500 RPM

Features:

- Compact (High Torque/Volume Ratio)
- Speeds to 7500 RPM Standard
- UL Recognized
- Rugged Resolver Feedback
- Built-in Thermostat
- Rear Shaft Extension
- Class H Insulation

Options:

- Front Mounted Gearheads
- Fail-Safe Brake
- IP65 and IP67 Sealing
- Encoder Feedback
- NEMA Mountings
- Mating Connectors

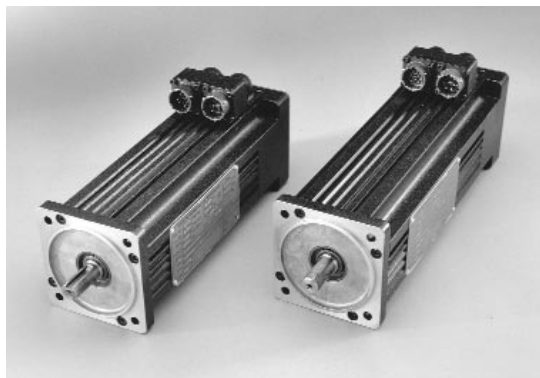

EB-Series (Explosion-Proof)

Explosion-Proof Brushless servomotors are listed by UL for use in Class 1, Division 1, Groups C and D hazardous locations. This listing includes applications where vapors or gases form flammable or explosive environments.

The EB-Series has been tested and proven capable to withstand internal explosion without bursting or allowing ignition to reach outside the motor frame. Contact the Kollmorgen Customer Support Network for more information.

- 0.84 to 149 N-m (0.62 to 110.0 lb-ft)
- 75.4 to 195.5 mm (2.97 to 7.70 inches) Square Frame
- Resolver Feedback
- Maximum Recommended Speed 7500 RPM

Features:

- Compact (High Torque/Volume Ratio)
- Speeds to 7500 RPM Standard
- UL Recognized
- Rugged Resolver Feedback
- Built-in Thermostat
- Class H Insulation

Options:

- Fail-Safe Brake
- NEMA Mountings

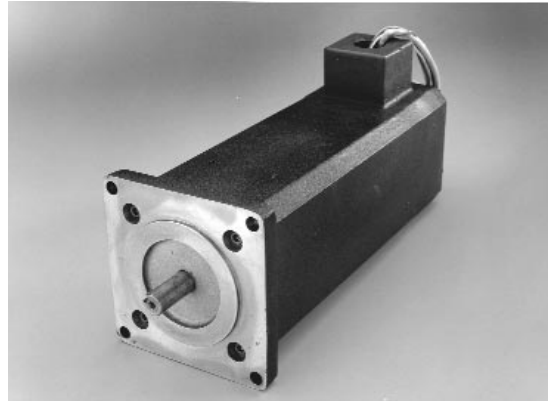

BE-Series (Low-Inertia), ME-Series (Medium-Inertia)

The BE and ME Series provides the same inertia advantages as the B and M Series. A commutation encoder is incorporated in place of the resolver. The encoder provides Hall tracks as well as data channels A and A, B and B, I and I.

- 0.84 to 149 N-m (0.62 to 110.0 lb-ft)
- 70.0 to 190.0 mm (2.76 to 7.48 inches) Square Frame
- Encoder Feedback
- Maximum Recommended Speed 6000 RPM

Features:

- Compact (High Torque/Volume Ratio)
- Speeds to 6000 RPM Standard
- UL Recognized
- Commutation Encoder Feedback (2048 LPR)
- Built-in Thermostat
- Rear Shaft Extension
- Class H Insulation

Options:

- Front Mounted Gearheads
- Failsafe Brake
- IP65 and IP67 Sealing
- NEMA Mountings
- Mating Connectors
- 1024 LPR Commutation Encoder



Kollmorgen GOLDLINE

10x PERFORMANCE DATA

Parameters	Symbols	Units	B-102-A	B-104-A
			BE-102-A	BE-104-A
			M-103-A	M-105-A
			ME-103-A	ME-105-A
			EB-102-A	EB-104-A
Horsepower	HP Rated	HP	0.73	1.2
Kilowatts	kW Rated	kW	0.54	0.90
Speed at Rated Power	N Rated	RPM	7500	5600
Max Operating Speed	N Max	RPM	7500	5600
Continuous Torque (stall) at 40°C	Tc	lb-ft	0.62	1.14
		N-m	0.84	1.55
Continuous Torque (stall) at 25°C	Tc	lb-ft	0.66	1.21
		N-m	0.89	1.64
Continuous Line Current	Ic	Amps RMS	2.4	3.00
Peak Torque	Tp	lb-ft	1.78	3.23
		N-m	2.41	4.38
Peak Line Current	Ip	Amps RMS	7.2	9.0
Max Theoretical				
Acceleration (B, BE, EB-10x) (M, ME-10x)	Z	rad / sec ²	78100	95000
		rad / sec ²	11400	13000
Torque Sensitivity (stall) ±10%	Kt	lb-ft / Amp RMS	0.26	0.38
		N-m / Amp RMS	0.35	0.51
Back EMF (line-to-line) ±10%	Kb	VRMS / kRPM	20.9	31
Max line-to-line Volts	VMax	Volts RMS	250	250
DC Res at 25°C				
(line-to-line) ±10%	Rm	Ohms	6.80	5.30
Inductance (line-to-line) ±30%	Lm	mh	30.0	28.1
Rotor Inertia (B, BE, EB-10x) (M, ME-10x)	Jm	lb-ft-sec ²	0.0000228	0.0000340
		kg-m ²	0.000031	0.0000461
		lb-ft-sec ²	0.000156	0.000249
		kg-m ²	0.000212	0.000338
Weight (B, BE-10x) (M, ME-10x) (EB-10x)	Wt	lb	5.5	7
		kg	2.5	3.2
	Wt	lb	7	9
		kg	3.2	4.1
	Wt	lb	5.5	7
		kg	2.5	3.2
Static Friction	Tf	lb-ft	0.03	0.04
		N-m	0.04	0.05
Thermal Time Constant				
(B, BE, M, ME-10x)	TCT	Min	10	11
Thermal Time Constant				
(EB-10x)	TCT	Min	2	3
Viscous Damping Z Source	Fi	lb-ft / kRPM	0.0015	0.0020
		N-m / kRPM	0.002	0.003
Motor Constant at 25°C	Km	lb-ft / √W	0.082	0.143
		N-m / √W	0.111	0.194
Thermal Resistance at stall	Rth	°C / Watt	1.30	1.07
Number of Poles			4	4

Continuous ratings with motor on 203 mm x 305 mm x 6.4 mm (8" x 12" x 0.25") isolated aluminum heat sink.

Windings with speeds to 12,000 RPM are available. Contact the Kollmorgen Customer Support Network for more information.

Kollmorgen GOLDLINE

10x PERFORMANCE DATA

B-104-B BE-104-B M-105-B ME-105-B EB-104-B	B-106-A BE-106-A M-107-A ME-107-A EB-106-A	B-106-B BE-106-B M-107-B ME-107-B EB-106-B	Units	Symbols
1.5	1.2	2.0	HP	HP Rated
1.1	0.90	1.5	kW	kW Rated
7500	4200	7500	RPM	N Rated
7500	4200	7500	RPM	N Max
1.16	1.62	1.64	lb-ft	Tc (at 40°C)
1.57	2.20	2.22	N-m	
1.23	1.72	1.74	lb-ft	Tc (at 25°C)
1.67	2.33	2.36	N-m	
4.20	3.0	6.0	Amps RMS	Ic
3.28	4.56	4.68	lb-ft	Tp
4.45	6.18	6.35	N-m	
12.6	9.0	18.0	Amps RMS	Ip
96500	80900	83000	rad / sec ²	Z (B, BE, EB-10x)
13200	11400	11700	rad / sec ²	Z (M, ME-10x)
0.27	0.53	0.27	lb-ft / Amp RMS	Kt
0.37	0.72	0.37	N-m / Amp RMS	
22.5	43.7	22.5	VRMS / kRPM	Kb
250	250	250	Volts RMS	VMax
2.72	6.50	1.60	Ohms	Rm
14.4	37.5	9.4	mh	Lm
0.0000340	0.0000564	0.0000564	lb-ft-sec ²	Jm (B, BE, EB-10x)
0.0000461	0.0000765	0.0000765	kg-m ²	
0.000249	0.00040	0.00040	lb-ft-sec ²	Jm (M, ME-10x)
0.000338	0.00054	0.00054	kg-m ²	
7	8.5	8.5	lb	Wt (B, BE-10x)
3.2	3.9	3.9	kg	
9	11	11	lb	Wt (M, ME-10x)
4.1	5	5	kg	
7.0	8.5	8.5	lb	Wt (EB-10x)
3.2	3.9	3.9	kg	
0.04	0.05	0.05	lb-ft	Tf
0.05	0.07	0.07	N-m	
11	12	12	Min	TCT (B, BE, M, ME-10x)
3	4	4	Min	TCT (EB-10x)
0.0020	0.003	0.003	lb-ft / kRPM	Fi
0.003	0.004	0.004	N-m / kRPM	
0.145	0.184	0.187	lb-ft / \sqrt{W}	Km (at 25°C)
0.196	0.249	0.253	N-m / \sqrt{W}	
1.07	0.87	0.89	°C / Watt	Rth
4	4	4	Number of Poles	

Kollmorgen GOLDLINE

10x PERFORMANCE DATA

B, EB-102-A, M-103-A with SR03
BE-102A, ME-103-A with SE03

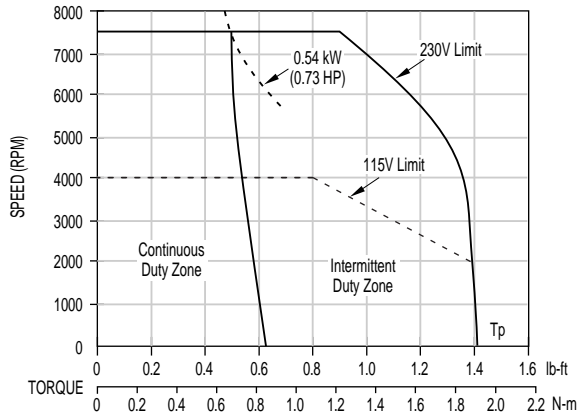

B, EB-104-A, M-105-A with SR03
BE-104A, ME-105-A with SE03

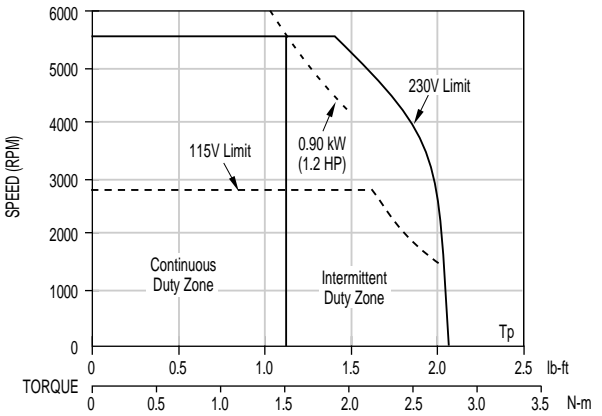

B, EB-104-B, M-105-B with SR06
BE-104-B, ME-105-B with SE06

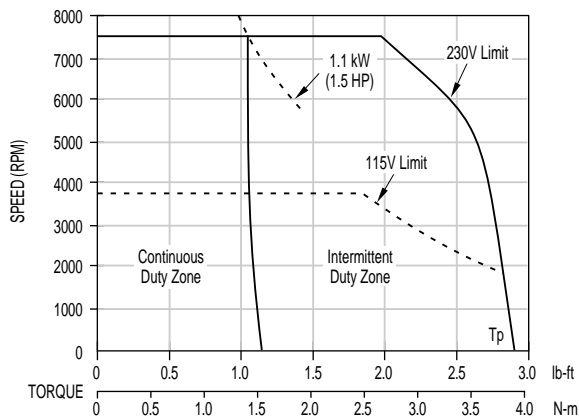

Note: Performance curves are also applicable for BDS4 and BDS5.

10x PERFORMANCE DATA

B, EB-106-A, M-107-A with SR03
BE-106-A, ME-107-A with SE03

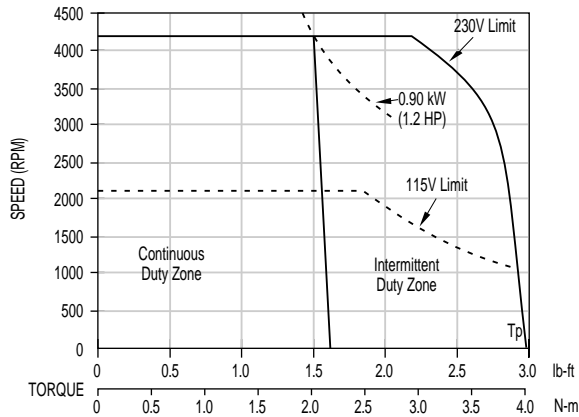

B, EB-106-A, M-107-A with SR06
BE-106-A, ME-107-A with SE06

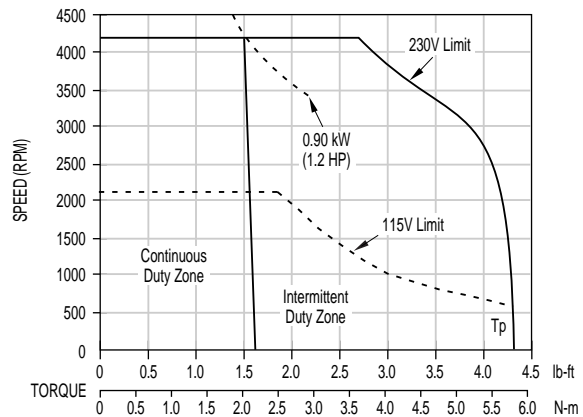

B, EB-106-B, M-107-B with SR06
BE-106-B, ME-107-B with SE06

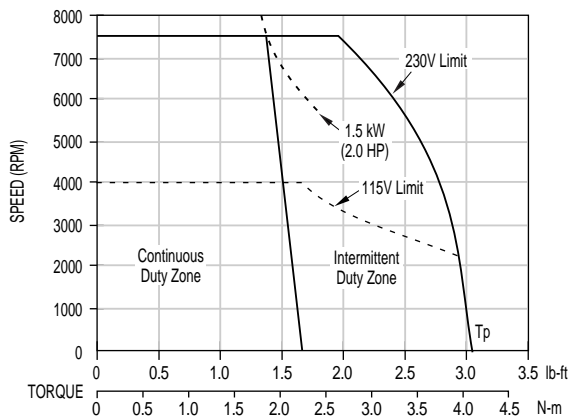

Note: Performance curves are also applicable for BDS4 and BDS5.

Kollmorgen GOLDLINE

DIMENSIONS

B, M-10x-x-24

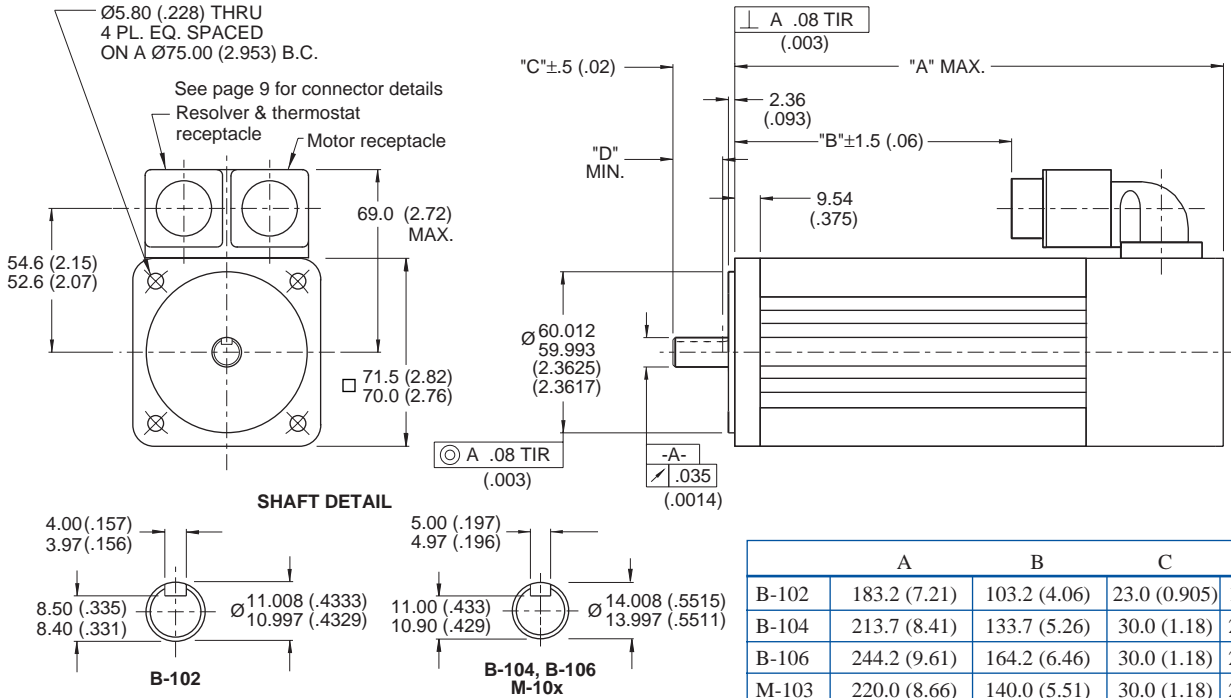

	A	B	C	D
B-102	183.2 (7.21)	103.2 (4.06)	23.0 (0.905)	18.0 (0.71)
B-104	213.7 (8.41)	133.7 (5.26)	30.0 (1.18)	20.0 (0.79)
B-106	244.2 (9.61)	164.2 (6.46)	30.0 (1.18)	20.0 (0.79)
M-103	220.0 (8.66)	140.0 (5.51)	30.0 (1.18)	20.0 (0.79)
M-105	262.1 (10.32)	182.1 (7.17)	30.0 (1.18)	20.0 (0.79)
M-107	314.5 (12.38)	234.5 (9.23)	30.0 (1.18)	20.0 (0.79)

Notes:

- BE and ME outline and dimension data and connector information is available by contacting the Kollmorgen Customer Support Network.
- Dimensions in mm (inches)

Tolerances, unless otherwise specified:

metric: X decimal place $\pm .4$, XX decimal places $\pm .13$

inches: XX decimal places $\pm .015$, XXX decimal places $\pm .005$

DIMENSIONS

EB-10x-x-11

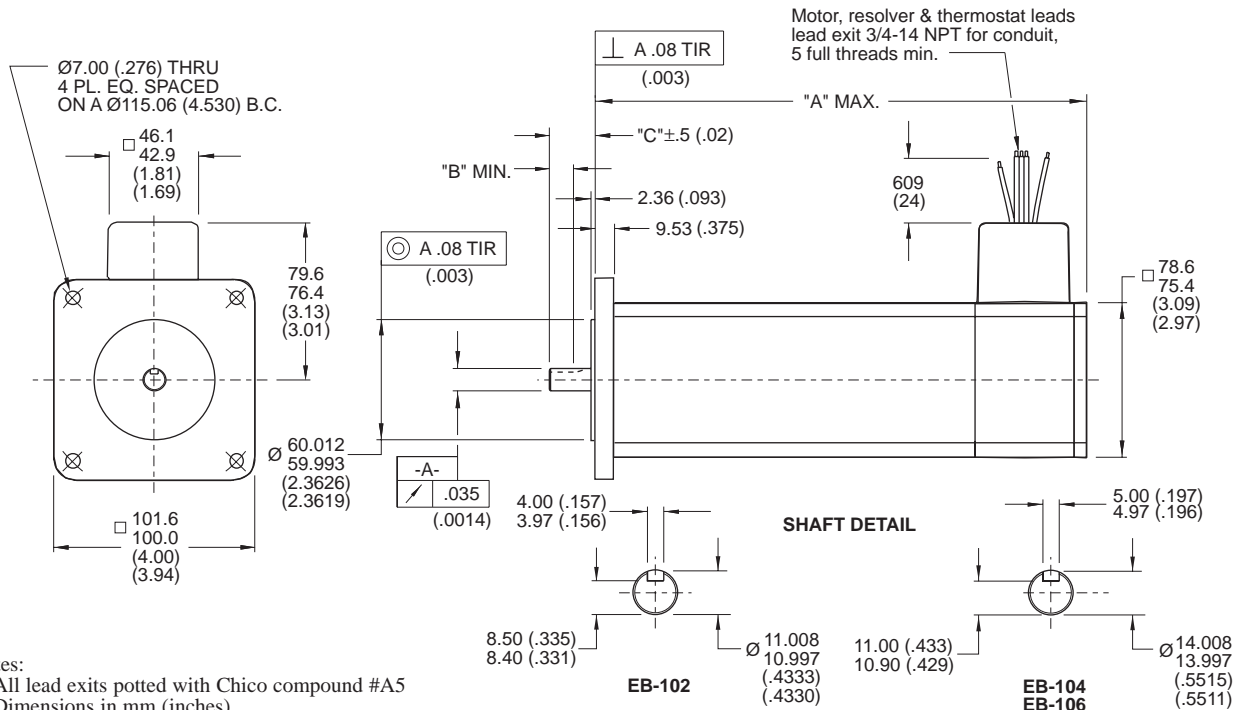

	A	B	C
EB-102	224.3 (8.83)	12.0 (.47)	23.0 (.90)
EB-104	254.8 (10.3)	18.5 (.73)	30.0 (1.18)
EB-106	285.3 (11.23)	18.5 (.73)	30.0 (1.18)

FLYING LEAD AND CONNECTOR PIN OUTS

Motor Receptacle MS-3122E-14-5P Straight Mating Plug MS-3116F-14-5S	Resolver/Option Receptacle MS-3122E-14-19P Straight Mating Plug MS-3116F-14-19S	Application Resolver Receptacle MS-3122E-14-12P Optional Straight Mating Plug MS-3116F-14-12S
Pin A - Phase A (brown)	Pin A - S3 (black), Sin Hi	Pin A - S1 (red), Sin Lo
Pin B - Phase B (red)	Pin B - S1 (red), Sin Lo	Pin B - S3 (black), Sin Hi
Pin C - Phase C (white)	Pin C - S4 (blue), Cos Lo	Pin C - S2 (yellow), Cos Hi
Pin D - Ground (green with yellow stripe)	Pin D - S2 (yellow), Cos Hi	Pin D - S4 (blue), Cos Lo
	Pin E - R1 (red/white), Ref Lo	Pin E - R1 (red/white), Ref Lo
	Pin F - R2 (yellow/white), Ref Hi	Pin F - R2 (yellow/white), Ref Hi
Options	Pin T } Normally closed contacts	
Pin N Optional DC fail-safe	Pin U } 4 Amp, 120 VAC - thermostat opens at 170°C ±5°C and closes at 132°C ±5°C	
Pin P brake, 24 VDC or 90 VDC (blue leads)		

Note: Color codes are applicable for EB-10x

Kollmorgen GOLDLINE

10x OPTIONS

B, BE-10x, M, ME-10x

<i>Sealing</i>	<i>Fail-safe brake</i>	<i>Additional feedback</i>
IP65 [pressure on shaft seal must not exceed 0.21 kg/cm ² (3 PSI)]	90 VDC (.28) Amps	Encoders
IP67 [pressure on shaft seal must not exceed 0.35 kg/cm ² (5 PSI)]	24 VDC (.93) Amps	Resolvers
	Holding torque: 1.7 lb-ft (2.3 N-m)	
	Inertia: 1.82 X 10 ⁻⁶ lb-ft-s ² 2.47 X 10 ⁻⁶ Kg-m ²	

B-10x, M-10x BRAKE OPTION

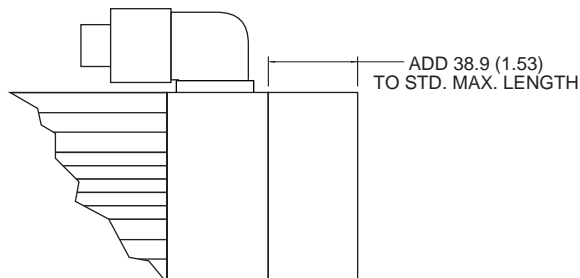

An integral electromagnetic fail-safe brake can be added to the rear of the motor. Operating in the POWER OFF/BRAKE ON mode, the brake provides 1.7 lb-ft (2.3 N-m) of torque for static parking and emergency braking.

B-10x, M-10x ENCODER OPTION

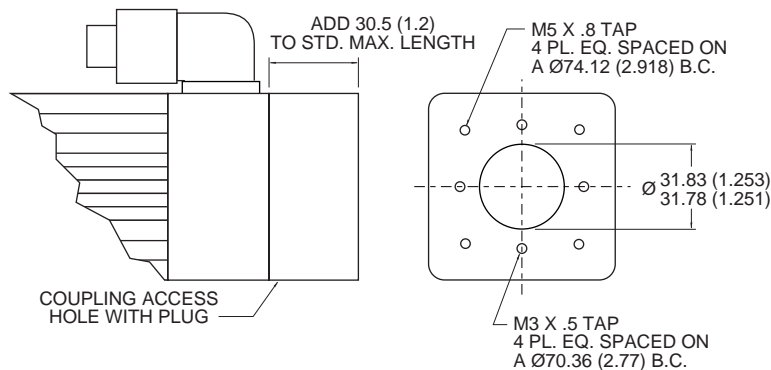

A feedback encoder adapter option provides direct coupling to a standard housed encoder. Encoder can be customer or factory supplied. Other mechanical variations are available by special request.

B-10x, M-10x FLYING LEAD OPTION

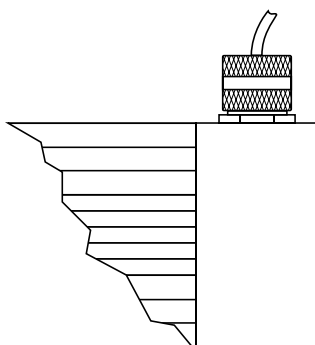

Flying leads are available providing an unterminated cable having 457 mm (18.0 in) minimum length.

BE-10x, ME-10x

A commutation encoder for system feedback is incorporated into the BE and ME Series in place of the resolver that is used in the B and M Series. The commutation encoder includes all the data channels (A, \bar{A} , B, \bar{B} , I and \bar{I}) as well as the Hall effect channels.

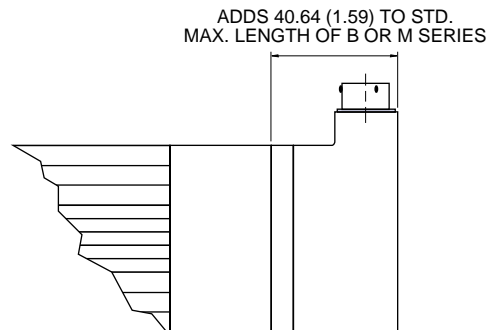

BE-10x, ME-10x BRAKE OPTION

An integral electromagnetic fail-safe brake can be added to the rear of the motor. Operating in a power off/brake on mode, the brake provides 1.7 lb-ft (2.3 N-m) of torque for static parking and emergency braking.

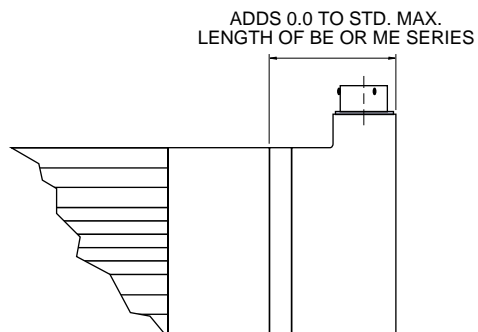

Kollmorgen GOLDLINE

20x PERFORMANCE DATA

Parameters	Symbols	Units	B-202-A	B-202-B	B-202-C	B-204-A
			BE-202-A	BE-202-B	BE-202-C	BE-204-A
			M-203-A	M-203-B	M-203-C	M-205-A
			ME-203-A	ME-203-B	ME-203-C	ME-205-A
			EB-202-A	EB-202-B	EB-202-C	EB-204-A
Horsepower	HP Rated	HP	0.80	1.3	2.0	1.1
Kilowatts	kW Rated	kW	0.60	1.0	1.5	0.82
Speed at Rated Power	N Rated	RPM	2500	3800	6200	1900
Max Operating Speed	N Max	RPM	2500	3800	6200	1900
Continuous Torque (stall) at 40°C	Tc	lb-ft	1.66	1.80	1.80	3.30
		N-m	2.25	2.44	2.44	4.47
Continuous Torque (stall) at 25°C	Tc	lb-ft	1.76	1.91	1.91	3.5
		N-m	2.39	2.59	2.59	4.7
Continuous Line Current	Ic	Amps RMS	1.70	3.0	5.00	2.7
Peak Torque	Tp	lb-ft	5.50	5.45	5.65	10.1
		N-m	7.45	7.38	7.65	13.7
Peak Line Current	Ip	Amps RMS	6.0	9.6	16.6	8.7
Max Theoretical						
Acceleration (B, BE, EB-20x) (M, ME-20x)	Z	rad / sec ²	74800	74100	76900	79200
		rad / sec ²	8910	8330	9160	12000
Torque Sensitivity (stall) ±10%	Kt	lb-ft / amp RMS	0.97	0.60	0.36	1.23
		N-m / Amp RMS	1.32	0.81	0.49	1.66
Back EMF (line-to-line) ±10%	Kb	VRMS / kRPM	79.5	49.0	29.4	100.5
Max line-to-line Volts	VMax	Volts RMS	250	250	250	250
DC Res at 25°C						
(line-to-line) ±10%	Rm	Ohms	17.7	6.98	2.34	9.46
Inductance (line-to-line) ±30%	Lm	mh	185.0	68.0	25.0	133.0
Rotor Inertia (B, BE, EB-20x) (M, ME-20x)	Jm	lb-ft-sec ²	0.0000735	0.0000735	0.0000735	0.0001275
		kg-m ²	0.0000996	0.0000996	0.0000996	0.0001729
		lb-ft-sec ²	0.000617	0.000617	0.000617	0.000843
		kg-m ²	0.000836	0.000836	0.000836	0.001143
Weight (B, BE-20x) (M, ME-20x) (EB-20x)	Wt	lb	9	9	9	13.6
		kg	4.1	4.1	4.1	6.2
	Wt	lb	11.0	11.0	11.0	16.0
		kg	5.0	5.0	5.0	7.3
	Wt	lb	15.0	15.0	15.0	18.0
		kg	6.8	6.8	6.8	8.2
Static Friction	Tf	lb-ft	0.06	0.06	0.06	0.07
		N-m	0.08	0.08	0.08	0.10
Thermal Time Constant						
(B, BE, M, ME-20x)	TCT	Min	18	18	18	20
Thermal Time Constant						
(EB-20x)	TCT	Min	18	18	18	20
Viscous Damping Z Source	Fi	lb-ft / kRPM	0.005	0.005	0.005	0.007
		N-m / kRPM	0.007	0.007	0.007	0.009
Motor Constant at 25°C	Km	lb-ft / √W	0.201	0.196	0.204	0.344
		N-m / √W	0.272	0.266	0.276	0.466
Thermal Resistance at stall	Rth	°C / Watt	1.0	0.81	0.87	0.74
Number of Poles			4	4	4	4

Continuous ratings with motor on 203 mm x 305 mm x 6.4 mm (8" x 12" x 0.25") isolated aluminum heat sink.

Kollmorgen GOLDLINE

20x PERFORMANCE DATA

B-204-B	B-204-C	B-206-A	B-206-B	B-206-C	B-206-D		
BE-204-B	BE-204-C	BE-206-A	BE-206-B	BE-206-C	BE-206-D		
M-205-B	M-205-C	M-207-A	M-207-B	M-207-C	M-207-D		
ME-205-B	ME-205-C	ME-207-A	ME-207-B	ME-207-C	ME-207-D		
EB-204-B	EB-204-C	EB-206-A	EB-206-B	EB-206-C	EB-206-D	Units	Symbols
2.1	3.8	1.3	2.5	3.8	5.0	HP	HP Rated
1.6	2.8	0.97	1.80	2.8	3.7	kW	kW Rated
3600	6200	1400	2800	4900	7000	RPM	N Rated
3600	6200	1400	2800	4900	7000	RPM	N Max
3.30	3.53	4.80	4.60	4.75	4.80	lb-ft	Tc (at 40°C)
4.47	4.79	6.51	6.24	6.44	6.51	N-m	
3.5	3.7	5.09	4.88	5.04	5.09	lb-ft	Tc (at 25°C)
4.7	5.1	6.9	6.62	6.83	6.90	N-m	
5.3	9.8	3.0	5.8	10.0	15.0	Amps RMS	Ic
10.2	10.1	15.1	14.7	14.4	14.7	lb-ft	Tp
13.8	13.7	20.5	19.9	19.5	19.9	N-m	
17.2	29.5	10.0	19.5	33.0	48.5	Amps RMS	Ip
80000	79200	81500	79300	77700	79300	rad / sec ²	Z (B, BE, EB-20x)
12100	12000	11600	11300	11100	11300	rad / sec ²	Z (M, ME-20x)
0.63	0.36	1.59	0.79	0.46	0.32	lb-ft / Amp RMS	Kt
0.85	0.49	2.15	1.08	0.62	0.43	N-m / Amp RMS	
51.2	29.6	130.0	65.1	37.7	26.2	VRMS / kRPM	Kb
250	250	250	250	250	250	Volts RMS	VMax
2.48	0.786	8.82	2.32	0.82	0.38	Ohms	Rm
38.0	12.0	130	32	11	5.3	mh	Lm
0.0001275	0.0001275	0.0001853	0.0001853	0.0001853	0.0001853	lb-ft-sec ²	Jm (B, BE, EB-20x)
0.0001729	0.0001729	0.0002512	0.0002512	0.0002512	0.0002512	kg-m ²	
0.000843	0.000843	0.0013	0.0013	0.0013	0.0013	lb-ft-sec ²	Jm (M, ME-20x)
0.001143	0.00143	0.0018	0.0018	0.0018	0.0018	kg-m ²	
13.6	13.6	16.7	16.7	16.7	16.7	lb	Wt (B, BE-20x)
6.2	6.2	7.6	7.6	7.6	7.6	kg	
16.0	16.0	21.0	21.0	21.0	21.0	lb	Wt (M, ME-20x)
7.3	7.3	9.5	9.5	9.5	9.5	kg	
18.0	18.0	21.0	21.0	21.0	21.0	lb	Wt (EB-20x)
8.2	8.2	9.5	9.5	9.5	9.5	kg	
0.07	0.07	0.08	0.08	0.08	0.08	lb-ft	Tf
0.10	0.10	0.11	0.11	0.11	0.11	N-m	
20	20	22	22	22	22	Min	TCT (B, BE, M, ME-20x)
20	20	22	22	22	22	Min	TCT (EB-20x)
0.007	0.007	0.009	0.009	0.009	0.009	lb-ft / kRPM	Fi
0.009	0.009	0.012	0.012	0.012	0.012	N-m / kRPM	
0.342	0.352	0.466	0.451	0.454	0.449	lb-ft / \sqrt{W}	Km (at 25°C)
0.464	0.477	0.632	0.611	0.616	0.609	N-m / \sqrt{W}	
0.73	0.68	0.64	0.65	0.62	0.60	°C / Watt	Rth
4	4	4	4	4	4	Number of Poles	

Kollmorgen GOLDLINE

SYSTEM PERFORMANCE

B, EB-202-A, M-203-A with SR03
BE-202-A, ME-203-A with SE03

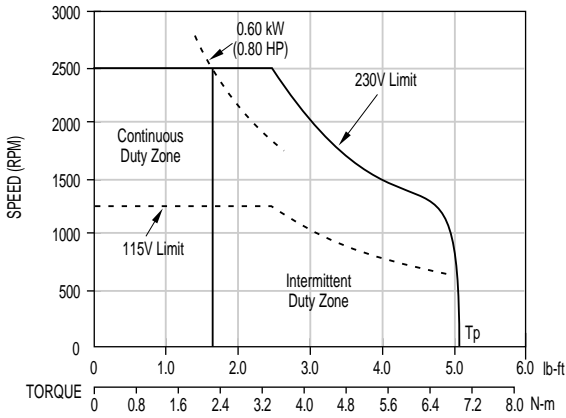

B, EB-202-B, M-203-B with SR03
BE-202-B, ME-203-B with SE03

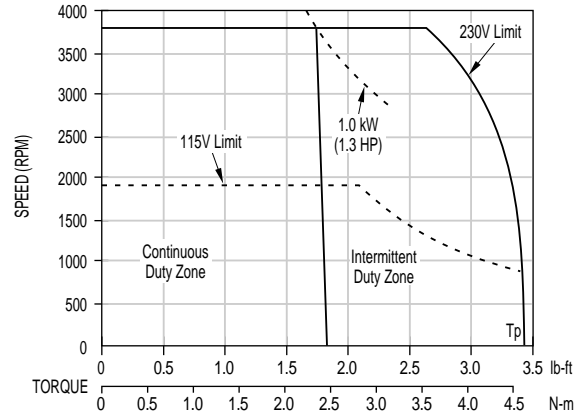

B, EB-202-C, M-203-C with SR06
BE-202-C, ME-203-C with SE06

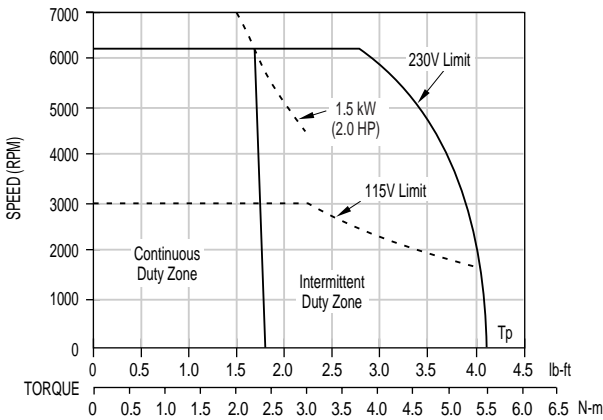

B, EB-204-A, M-204-A with SR03
BE-204-A, ME-204-A with SE03

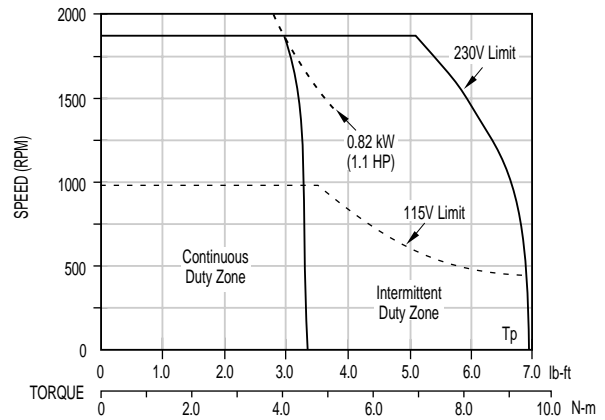

B, EB-204-A, M-205-A with SR06
BE-204-A, ME-205-A with SE06

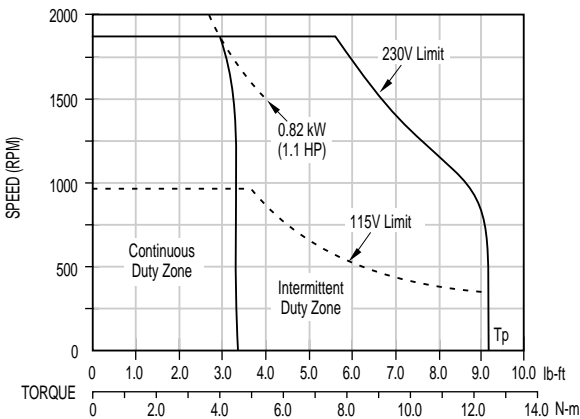

B, EB-204-B, M-205-B with SR06
BE-204-B, ME-205-B with SE06

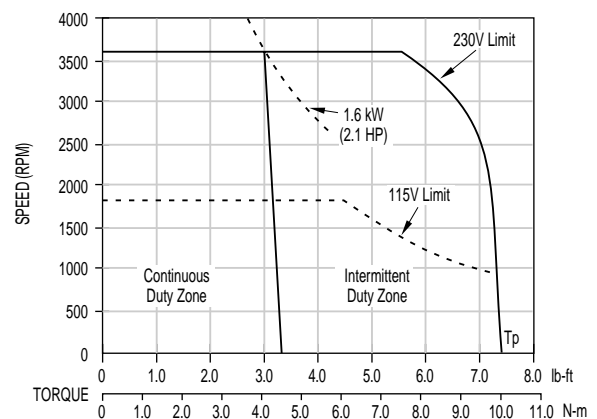

Note: Performance curves are also applicable for BDS4 and BDS5.

SYSTEM PERFORMANCE

B, EB-204-C, M-205-C with SR10
BE-204-C, ME-205-C with SE10

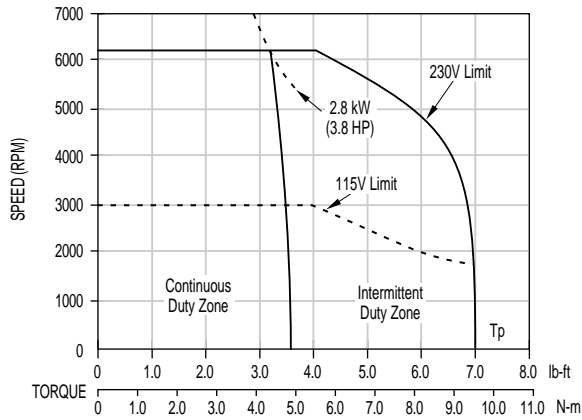

B, EB-206-A, M-207-A with SR03
BE-206-A, ME-207-A with SE03

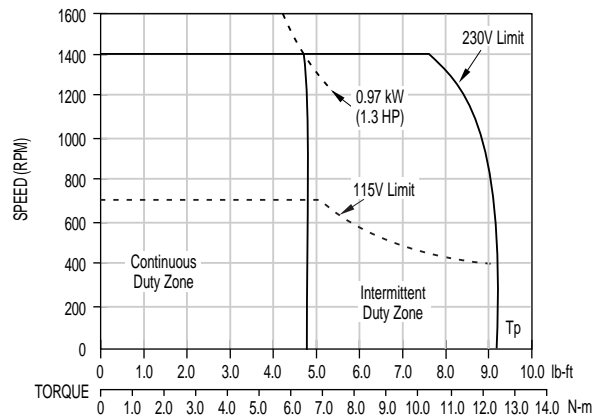

B, EB-206-B, M-207-B with SR06
BE-206-B, ME-207-B with SE06

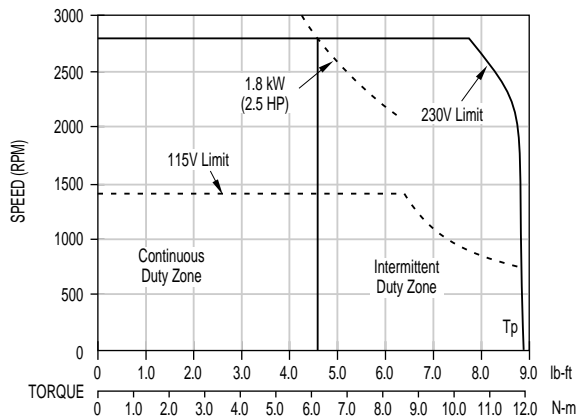

B, EB-206-C, M-207-C with SR10
BE-206-C, ME-207-C with SE10

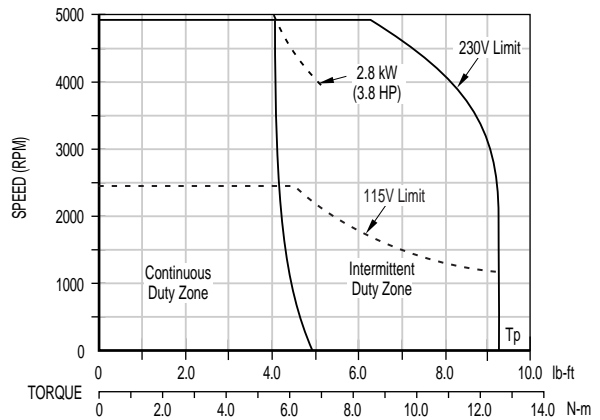

B, EB-206-D, M-207-D with SR20
BE-206-D, ME-207-D with SE20

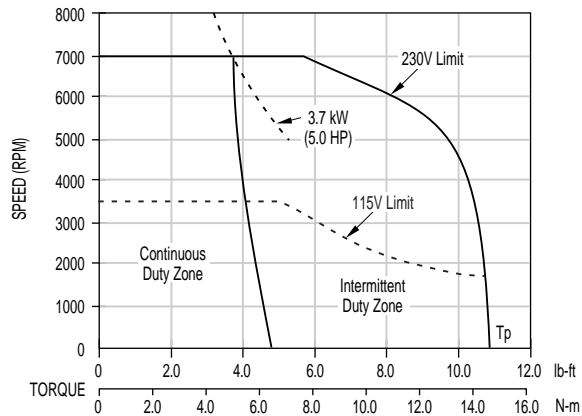

Note: Performance curves are also applicable for BDS4 and BDS5.

Kollmorgen GOLDLINE

DIMENSIONS

B, M-20x-x-23

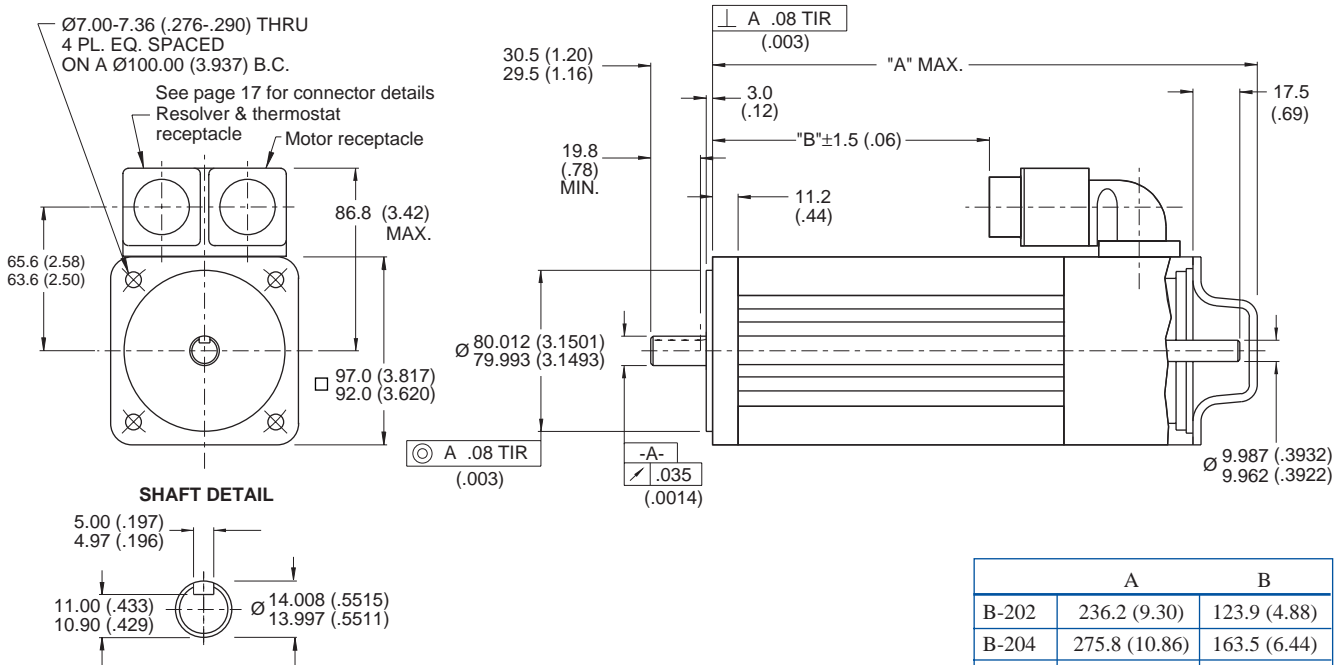

Notes:

- BE and ME outline and dimension data and connector information is available by contacting the Kollmorgen Customer Support Network.
- Dimensions in mm (inches)

Tolerances, unless otherwise specified:

metric: X decimal place ±.4, XX decimal places ±.13

inches: XX decimal places ±.015, XXX decimal places ±.005

DIMENSIONS

EB-20x-x-11

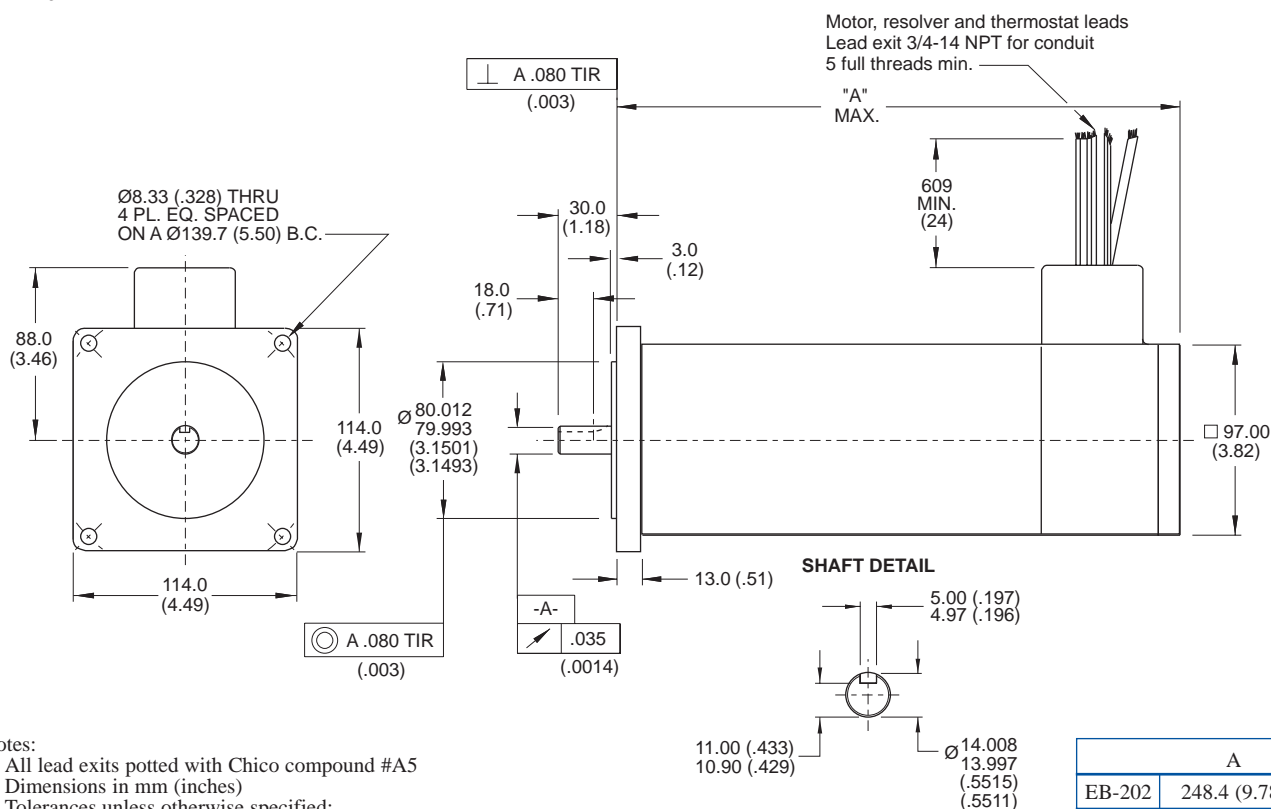

Notes:

1. All lead exits potted with Chico compound #A5
2. Dimensions in mm (inches)
Tolerances, unless otherwise specified:
metric: X decimal place ±.4, XX decimal places ±.13
inches: XX decimal places ±.015, XXX decimal places ±.005

	A
EB-202	248.4 (9.78)
EB-204	288.0 (11.34)
EB-206	327.7 (12.90)

FLYING LEAD AND CONNECTOR PIN OUTS

Motor Receptacle MS-3122E-14-5P Straight Mating Plug MS-3116F-14-5S	Resolver/Option Receptacle MS-3122E-14-19P Straight Mating Plug MS-3116F-14-19S	Application Resolver Receptacle MS-3122E-14-12P Optional Straight Mating Plug MS-3116F-14-12S
Pin A - Phase A (brown)	Pin A - S3 (black), Sin Hi	Pin A - S1 (red), Sin Lo
Pin B - Phase B (red)	Pin B - S1 (red), Sin Lo	Pin B - S3 (black), Sin Hi
Pin C - Phase C (white)	Pin C - S4 (blue), Cos Lo	Pin C - S2 (yellow), Cos Hi
Pin D - Ground (green with yellow stripe)	Pin D - S2 (yellow), Cos Hi	Pin D - S4 (blue), Cos Lo
	Pin E - R1 (red/white), Ref Lo	Pin E - R1 (red/white), Ref Lo
	Pin F - R2 (yellow/white), Ref Hi	Pin F - R2 (yellow/white), Ref Hi
Options	Pin T } Normally closed contacts	
Pin R } Optional brush tachometer (R-black, S-white)	Pin U } 4 Amp, 120 VAC - thermostat opens at 170°C ±5°C and closes at 132°C ±5°C (B, M-20x -- black leads; EB-20x -- white leads)	
Pin N } Optional DC fail-safe		
Pin P } brake, 24 VDC or 90 VDC (blue leads)		

Note: Color codes are applicable for EB-20x

Kollmorgen GOLDLINE

20x OPTIONS

B, BE-20x, M, ME-20x

Sealing

IP65 [pressure on shaft seal must not exceed 0.21 kg/cm² (3 PSI)]
 IP67 [pressure on shaft seal must not exceed 0.35 kg/cm² (5 PSI)]

Fail-safe brake

90 VDC (.39) Amps
 24 VDC (1.27) Amps
 Holding torque:
 4.4 lb-ft (6.0 N-m)
 Inertia:
 1.82 X 10⁻⁶ lb-ft-s²
 2.47 X 10⁻⁶ Kg-m²

Additional feedback

Encoders
 Resolvers

Brush-type tachometer

0.6% average/peak voltage ripple

B-20x, M-20x BRAKE OPTION

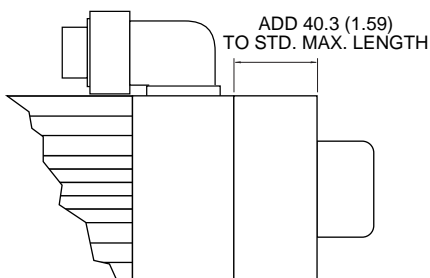

An integral electromagnetic fail-safe brake can be added to the rear of the motor. Operating in the POWER OFF/BRAKE ON mode, the brake provides 4.4 lb-ft (6.0 N-m) of torque for static parking and emergency braking.

B-20x, M-20x RESOLVER OPTION

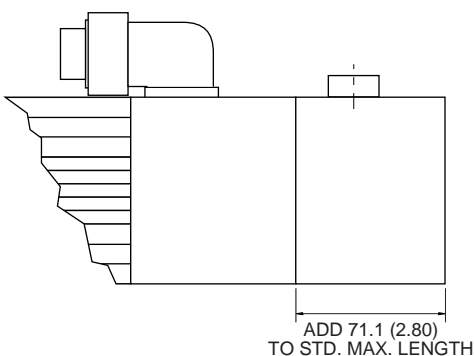

A feedback resolver option provides a direct-coupled Size 11 brushless resolver. Protected by the motor housing, a wide choice of resolvers is available to be compatible with the majority of CNC and other loop controllers.

B-20x, M-20x ENCODER OPTION

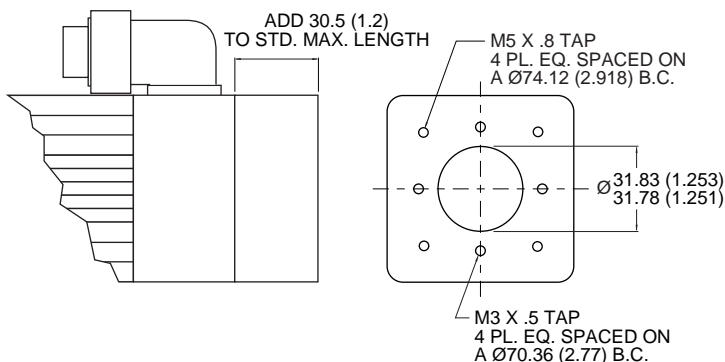

A feedback encoder adapter option provides direct coupling to a standard housed encoder. Encoder can be customer or factory supplied. Other mechanical variations are available by special request.

B-20x, M-20x TACHOMETER OPTION

An optional 0.6% average to peak voltage ripple DC tachometer is available to provide smooth speed control at extremely low speeds. It is offered in a range of sensitivities to suit particular application needs.

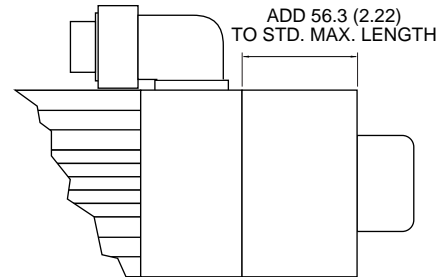

BE-20x, ME-20x

A commutation encoder for system feedback is incorporated into the BE and ME Series in place of the resolver that is used in the B and M Series. The commutation encoder includes all the data channels (A, \bar{A} , B, \bar{B} , I and \bar{I}) as well as the Hall effect channels.

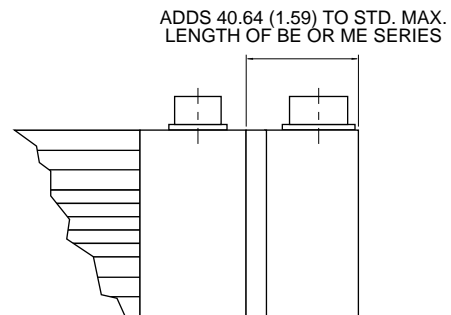

BE-20x, ME-20x BRAKE OPTION

An integral electromagnetic fail-safe brake can be added to the rear of the motor. Operating in a POWER OFF/BRAKE ON mode, the brake provides 4.4 lb-ft (6.0 N-m) of torque for static parking and emergency braking.

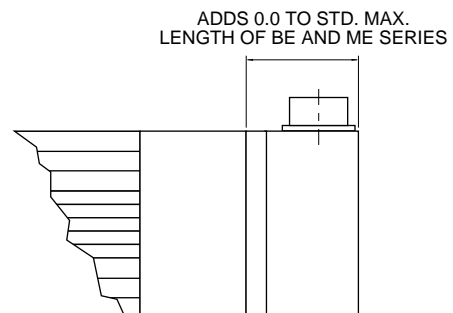

Kollmorgen GOLDLINE

40x PERFORMANCE DATA

Parameters	Symbols	Units	B-402-A	B-402-B	B-402-C	B-404-A
			BE-402-A	BE-402-B	BE-402-C	BE-404-A
			M-403-A	M-403-B	M-403-C	M-405-A
			ME-403-A	ME-403-B	ME-403-C	ME-405-A
			EB-402-A	EB-402-B	EB-402-C	EB-404-A
Horsepower	HP Rated	HP	1.3	2.9	3.8	2.7
Kilowatts	kW Rated	kW	0.97	2.2	2.8	2.0
Speed at Rated Power	N Rated	RPM	1500	3000	5000	1500
Max Operating Speed	N Max	RPM	1500	3000	5000	1500
Continuous Torque (stall) at 40°C	Tc	lb-ft	5.0	5.0	4.8	9.6
		N-m	6.8	6.8	6.5	13.0
Continuous Torque (stall) at 25°C	Tc	lb-ft	5.3	5.5	5.1	10.2
		N-m	7.2	7.4	6.9	13.8
Continuous Line Current	Ic	Amps RMS	3.0	6.4	9.8	6.0
Peak Torque	Tp	lb-ft	14.6	14.6	14.6	26.5
		N-m	19.8	19.8	19.8	35.9
Peak Line Current	Ip	Amps RMS	9.3	18.8	31.3	16.4
Max Theoretical						
Acceleration (B, BE, EB-40x) (M, ME-40x)	Z	rad / sec ²	61300	61300	61300	54800
		rad / sec ²	7640	7640	7640	8150
Torque Sensitivity (stall) ±10%	Kt	lb-ft / Amp RMS	1.66	0.82	0.49	1.70
		N-m / Amp RMS	2.51	1.11	0.66	2.31
Back EMF (line-to-line) ±10%	Kb	VRMS / kRPM	136.0	67.2	40.2	139.0
Max line-to-line Volts	VMax	Volts RMS	250	250	250	250
DC Res at 25°C						
(line-to-line) ±10%	Rm	Ohms	10.5	2.60	0.97	4.10
Inductance (line-to-line) ±30%	Lm	mh	220	50	21	102
Rotor Inertia (B, BE, EB-40x) (M, ME-40x)	Jm	lb-ft-sec ²	0.000238	0.000238	0.000238	0.000484
		kg-m ²	0.000323	0.000323	0.000323	0.000656
		lb-ft-sec ²	0.00191	0.00191	0.00191	0.00325
		kg-m ²	0.00259	0.00259	0.00259	0.00441
Weight (B, BE-40x) (M, ME-40x) (EB-40x)	Wt	lb	18.5	18.5	18.5	27.5
		kg	8.4	8.4	8.4	12.5
	Wt	lb	23	23	23	34
		kg	10.5	10.5	10.5	15.5
	Wt	lb	18.5	18.5	18.5	27.5
		kg	8.4	8.4	8.4	12.5
Static Friction	Tf	lb-ft	0.18	0.18	0.18	0.19
		N-m	0.24	0.24	0.24	0.26
Thermal Time Constant						
(B, BE, M, ME-40x)	TCT	Min	22	22	22	25
Thermal Time Constant						
(EB-40x)	TCT	Min	6	6	6	9
Viscous Damping Z Source	Fi	lb-ft / kRPM	0.011	0.011	0.011	0.013
		N-m / kRPM	0.015	0.015	0.015	0.018
Motor Constant at 25°C	Km	lb-ft / √W	0.446	0.433	0.430	0.683
		N-m / √W	0.604	0.587	0.583	0.926
Thermal Resistance at stall	Rth	°C / Watt	0.54	0.48	0.55	0.35
Number of Poles			4	4	4	4

Kollmorgen GOLDLINE

40x PERFORMANCE DATA

B-404-B	B-404-C	B-404-D	B-406-A	B-406-B	B-406-C		
BE-404-B	BE-404-C	BE-404-D	BE-406-A	BE-406-B	BE-406-C		
M-405-B	M-405-C	M-404-D	M-407-A	M-407-B	M-407-C		
ME-405-B	ME-405-C	ME-404-D	ME-407-A	ME-407-B	ME-407-C		
EB-404-B	EB-404-C	EB-404-D	EB-406-A	EB-406-B	EB-406-C	Units	Symbols
4.5	7.3	6.0	3.9	7.4	9.6	HP	HP Rated
3.4	5.4	4.5	2.9	5.5	7.2	kW	kW Rated
2500	5000	3700	1700	3200	5000	RPM	N Rated
2500	5000	3700	1700	3200	5000	RPM	N Max
9.8	9.7	9.7	13.0	13.7	12.5	lb-ft	Tc (at 40°C)
13.3	13.1	13.1	17.6	18.6	17.0	N-m	
10.4	10.3	10.3	13.8	14.5	13.3	lb-ft	Tc (at 25°C)
14.1	13.9	14.0	18.7	19.7	18.0	N-m	
9.9	19.8	15.0	9.5	19.1	27.2	Amps RMS	Ic
27.0	26.0	27.6	35.8	36.5	35.6	lb-ft	Tp
36.6	35.3	37.5	48.5	49.5	48.3	N-m	
28.8	55.9	45.0	27.3	53.3	81.4	Amps RMS	Ip
55800	53700	57000	52300	53300	52000	rad / sec ²	Z (B, BE, EB-40x)
8310	8000	8490	7380	7530	7340	rad / sec ²	Z (M, ME-40x)
0.99	0.49	0.647	1.38	0.72	0.46	lb-ft / Amp RMS	Kt
1.34	0.66	0.877	1.87	0.98	0.63	N-m / Amp RMS	
81.2	40.2	53.0	113.0	58.8	37.7	VRMS / kRPM	Kb
250	250	250	250	250	250	Volts RMS	VMax
1.32	0.34	0.63	1.70	0.44	0.20	Ohms	Rm
33.5	8.4	15.0	42	12	4.8	mh	Lm
0.000484	0.000484	0.000484	0.000685	0.000685	0.000685	lb-ft-sec ²	Jm (B, BE, EB-40x)
0.000656	0.000656	0.000656	0.000929	0.000929	0.000929	kg-m ²	
0.00325	0.00325	0.00325	0.00485	0.00485	0.00485	lb-ft-sec ²	Jm (M, ME-40x)
0.00441	0.00441	0.00441	0.00657	0.00657	0.00657	kg-m ²	
27.5	27.5	27.5	35.0	35.0	35.0	lb	Wt (B, BE-40x)
12.5	12.5	12.5	15.9	15.9	15.9	kg	
34	34	34	44	44	44	lb	Wt (M, ME-40x)
15.5	15.5	15.5	20	20	20	kg	
27.5	27.5	27.5	47.6	47.6	47.6	lb	Wt (EB-40x)
12.5	12.5	12.5	21.5	21.5	21.5	kg	
0.19	0.19	0.19	0.212	0.212	0.212	lb-ft	Tf
0.26	0.26	0.26	0.287	0.287	0.287	N-m	
25	25	25	28	28	28	Min	TCT (B, BE, M, ME-40x)
9	9	9	12	12	12	Min	TCT (EB-40x)
0.013	0.013	0.013	0.015	0.015	0.015	lb-ft / kRPM	Fi
0.018	0.018	0.018	0.020	0.020	0.020	N-m / kRPM	
0.746	0.724	0.702	0.907	0.937	0.892	lb-ft / \sqrt{W}	Km (at 25°C)
1.01	0.982	0.952	1.23	1.27	1.21	N-m / \sqrt{W}	
0.40	0.38	0.36	0.33	0.32	0.35	°C / Watt	Rth
4	4	4	4	4	4	Number of Poles	

Kollmorgen GOLDLINE

SYSTEM PERFORMANCE

B, EB-402-A, M-403-A with SR03
BE-402-A, ME-403-A with SE03

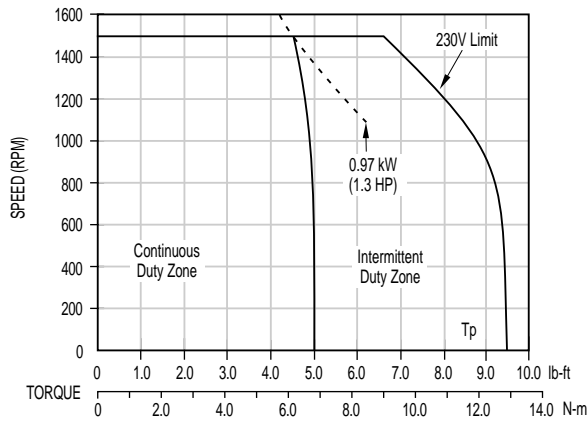

B, EB-402-B, M-403-B with SR06
BE-402-A, ME-403-B with SE06

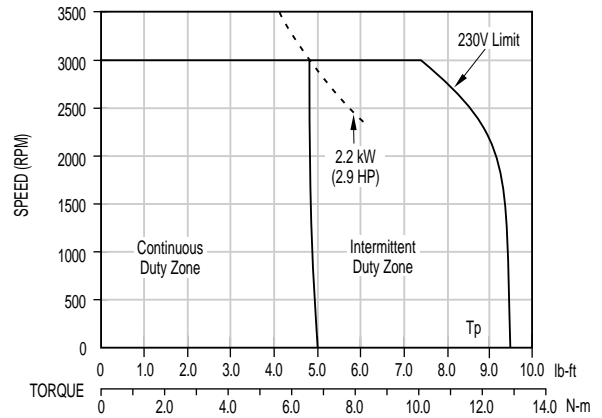

B, EB-402-B, M-403-B with SR10
BE-402-B, ME-403-B with SE10

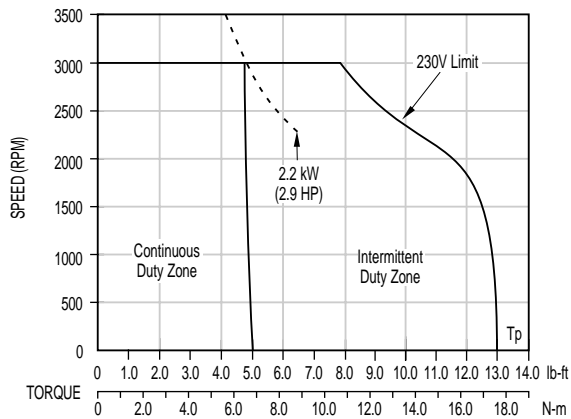

B, EB-402-C, M-403-C with SR10
BE-402-C, ME-403-C with SE10

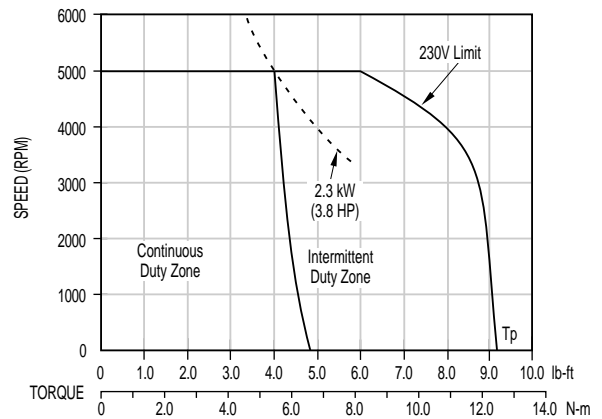

B, EB-404-A, M-405-A with SR06
BE-404-A, ME-405-A with SE06

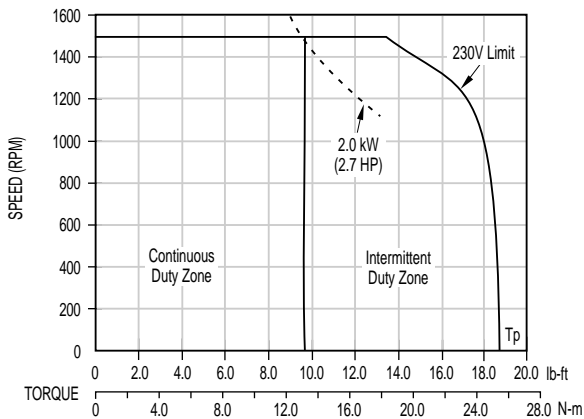

B, EB-404-B, M-405-B with SR10
BE-404-B, ME-405-B with SE10

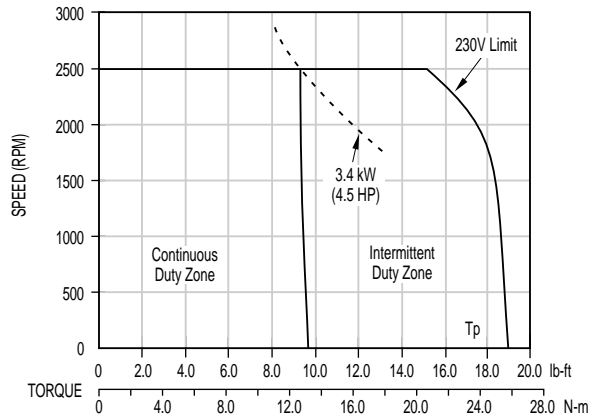

Note: Performance curves are also applicable for BDS4 and BDS5.

SYSTEM PERFORMANCE

B, EB-404-C, M-405-C with SR20
BE-404-C, ME-405-C with SE20

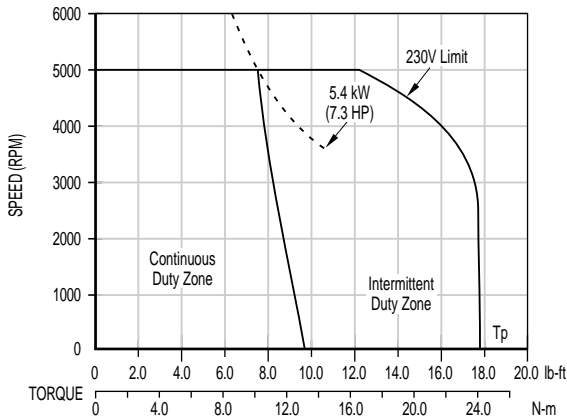

B, EB-404-D, M-405-D with SR20
BE-404-D, ME-405-D with SE20

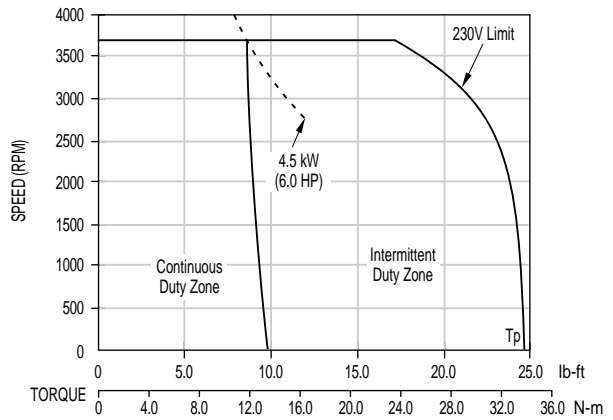

B, EB-406-A, M-407-A with SR10
BE-406-A, ME-407-A with SE10

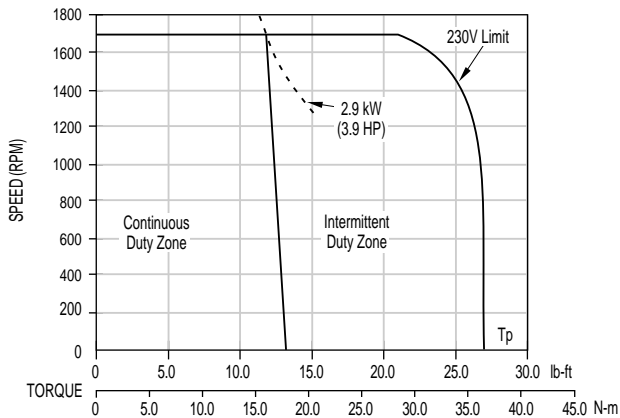

B, EB-406-A, M-407-A with SR20
BE-406-A, ME-407-A with SE20

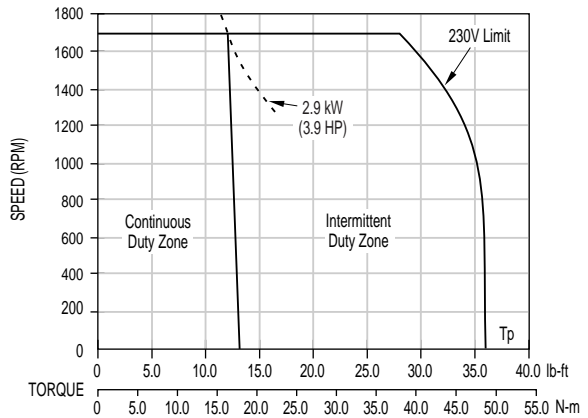

B, EB-406-B, M-407-B with SR20
BE-406-B, ME-407-B with SE20

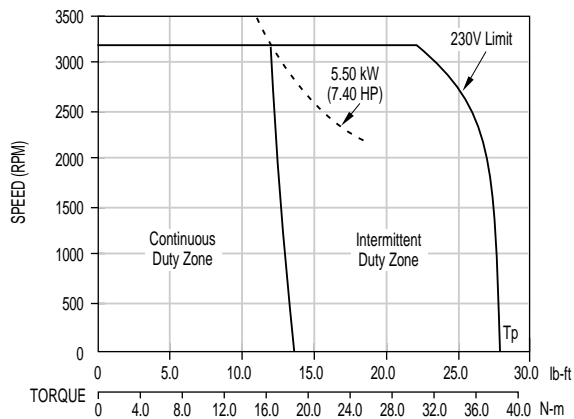

B, EB-406-C, M-407-C with SR30
BE-406-C, ME-407-C with SE30

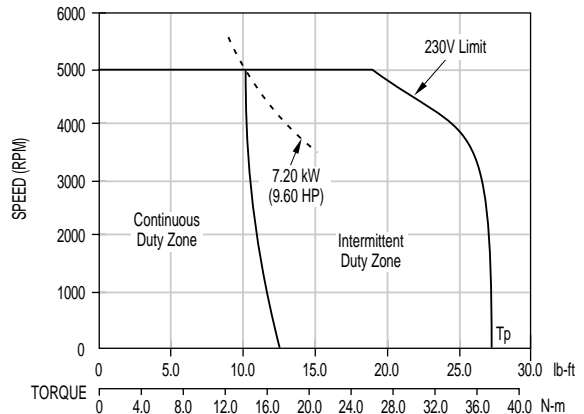

Note: Performance curves are also applicable for BDS4 and BDS5.

Kollmorgen GOLDLINE

SYSTEM PERFORMANCE

B, M-40x-x-A3

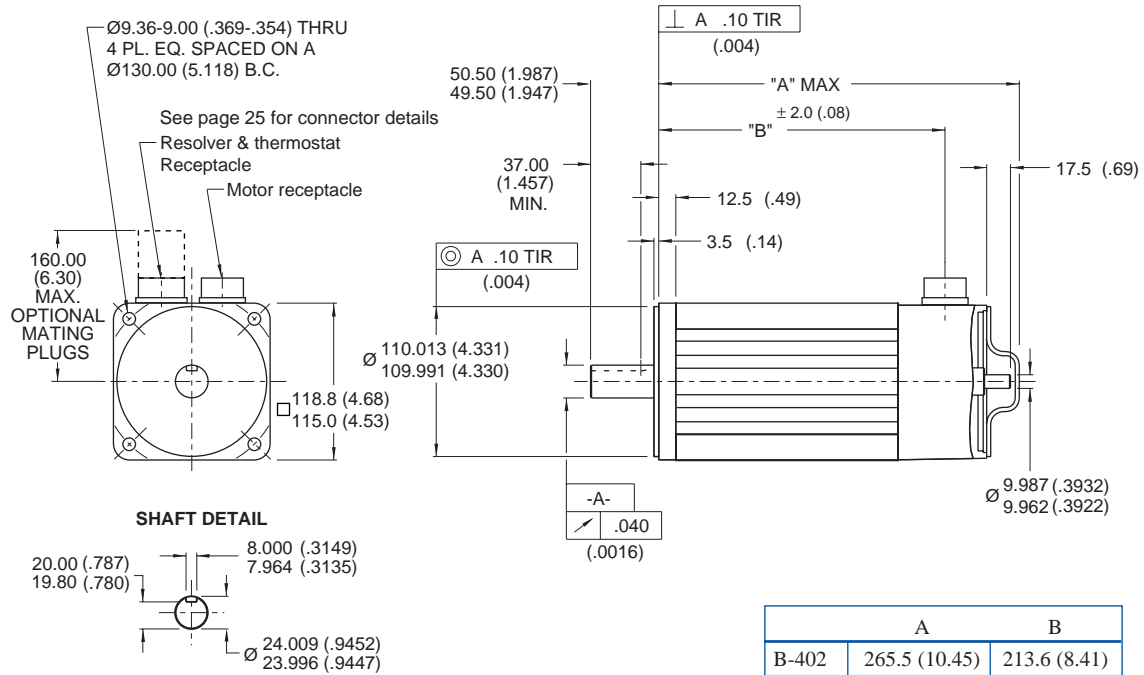

Notes:

- BE and ME outline and dimension data and connector information is available by contacting the Kollmorgen Customer Support Network.
- Dimensions in mm (inches)
 Tolerances, unless otherwise specified:
 metric: X decimal place $\pm .4$, XX decimal places $\pm .13$
 inches: XX decimal places $\pm .015$, XXX decimal places $\pm .005$

	A	B
B-402	265.5 (10.45)	213.6 (8.41)
B-404	318.8 (12.55)	266.9 (10.51)
B-406	372.1 (14.65)	320.2 (12.61)
M-403	318.8 (12.55)	266.9 (10.51)
M-405	372.1 (14.65)	320.2 (12.61)
M-407	444.9 (17.52)	393.0 (12.47)

DIMENSIONS

EB-40x-x-11

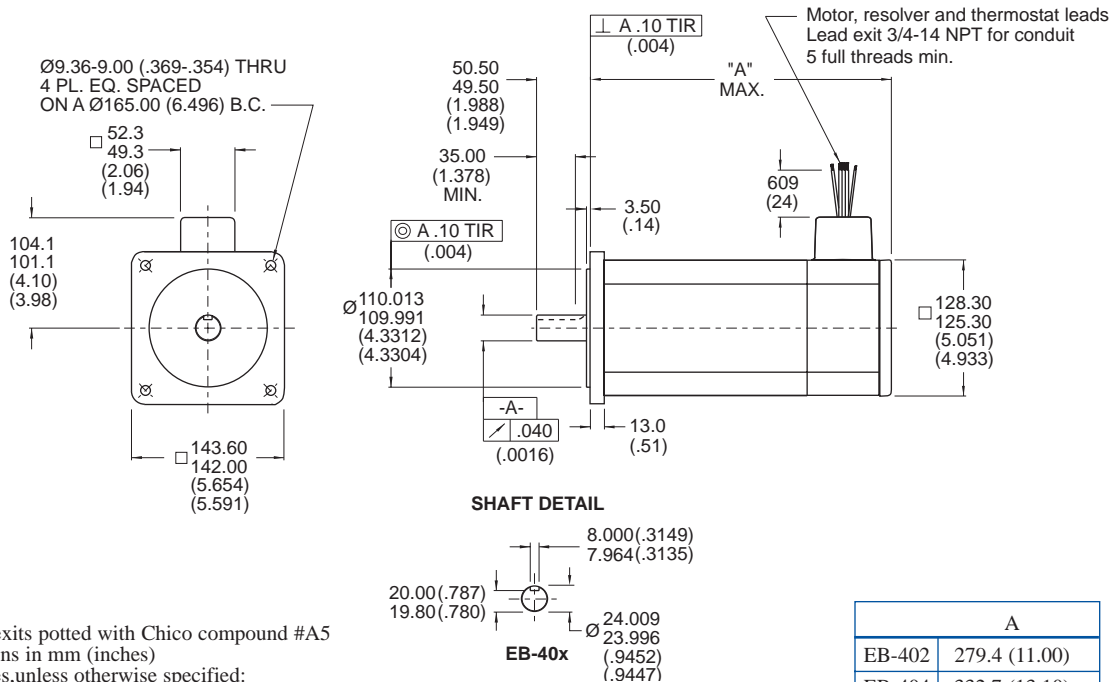

Notes:

- All lead exits potted with Chico compound #A5
- Dimensions in mm (inches)
 Tolerances, unless otherwise specified:
 metric: X decimal place $\pm .4$, XX decimal places $\pm .13$
 inches: XX decimal places $\pm .015$, XXX decimal places $\pm .005$

FLYING LEAD AND CONNECTOR PIN OUTS

Motor Receptacle MS-3102E-18-10P Straight Mating Plug MS-3106E-18-10S	Resolver/Option Receptacle MS-3102E-22-14P Straight Mating Plug MS-3106E-22-14S	Application Resolver Receptacle MS-3102E-20-33P Optional Straight Mating Plug MS-3106E-20-33S
Pin A - Phase A (brown) Pin B - Phase B (red) Pin C - Phase C (white) Pin D - Ground (green with yellow stripe)	Pin A - S3 (black), Sin Hi Pin B - S1 (red), Sin Lo Pin C - S4 (blue), Cos Lo Pin D - S2 (yellow), Cos Hi Pin E - R1 (red/white), Ref Lo Pin F - R2 (yellow/white), Ref Hi	Pin A - S1 (red), Sin Lo Pin B - S3 (black), Sin Hi Pin C - S2 (yellow), Cos Hi Pin D - S4 (blue), Cos Lo Pin E - R1 (red/white), Ref Lo Pin F - R2 (yellow/white), Ref Hi
Options Pin R } Optional brush Pin S } tachometer (R-black, S-white)	Pin T } Normally closed contacts Pin U } 4 Amp, 120 VAC - thermo- stat opens at $170^{\circ}\text{C} \pm 5^{\circ}\text{C}$ and closes at $132^{\circ}\text{C} \pm 5^{\circ}\text{C}$ (B, M-40x -- yellow leads; EB-40x -- white leads)	
Pin N } Optional DC fail-safe Pin P } brake, 24 VDC or 90 VDC (blue leads)		

Note: Color codes are applicable for EB-40x

Kollmorgen GOLDLINE

40x OPTIONS

B, BE-40x, M, ME-40x

Sealing

IP65 [pressure on shaft seal must not exceed 0.21 kg/cm² (3 PSI)]
 IP67 [pressure on shaft seal must not exceed 0.35 kg/cm² (5 PSI)]

Fail-safe brake

90 VDC (.28) Amps
 24 VDC (.93) Amps
 Holding torque:
 6.0 lb-ft (8.0 N-m)
 Inertia:
 4.32 X 10⁻⁵ lb-ft-s²
 5.86 X 10⁻⁵ Kg-m²

Additional feedback

Encoders
 Resolvers

Brush-type tachometer

0.6% average/peak voltage ripple

B-40x, M-40x BRAKE OPTION

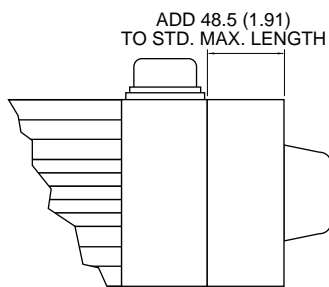

An integral electromagnetic fail-safe brake can be added to the rear of the motor. Operating in the POWER OFF/BRAKE ON mode, the brake provides 6.0 lb-ft (8.0 N-m) of torque for static parking and emergency braking.

B-40x, M-40x RESOLVER OPTION

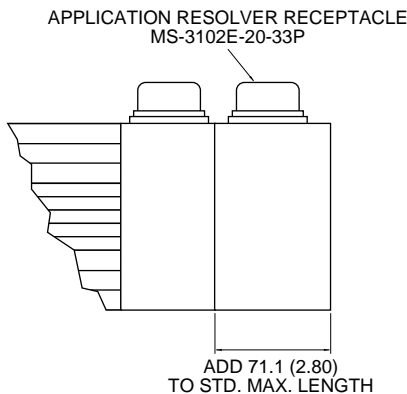

A feedback resolver option provides a direct-coupled Size 11 brushless resolver. Protected by the motor housing, a wide choice of resolvers is available to be compatible with the majority of CNC and other loop controllers.

B-40x, M-40x ENCODER OPTION

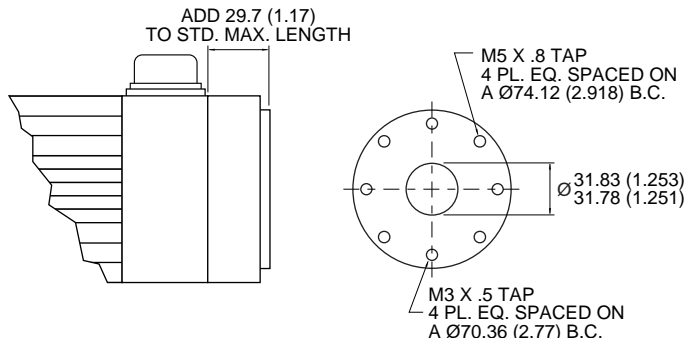

A feedback encoder adapter option provides direct coupling to a standard housed encoder. Encoder can be customer or factory supplied. Other mechanical variations are available by special request.

B-40x, M-40x TACHOMETER OPTION

An optional 0.6% average to peak voltage ripple DC tachometer is available to provide smooth speed control at extremely low speeds. It is offered in a range of sensitivities to suit particular application needs.

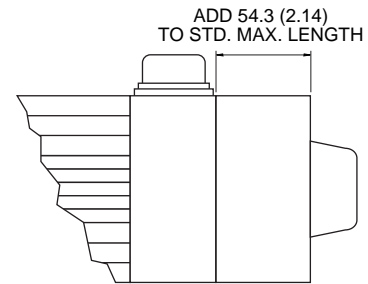

B-40x, M-40x BAYONET CONNECTOR OPTION

Bayonet type MS connectors are available along with mating plugs or factory cables to allow easy connection to Kollmorgen amplifiers.

	Motor	Resolver/Option	Application Resolver
Receptacle	CIR-020R-18-10P-F80*	MS-3122E-14-19P	MS-3122E-14-12P
Mating Plug	CIR-06F-18-10S*	MS-3116F-14-19S	MS-3116F-14-12S

* or equivalent

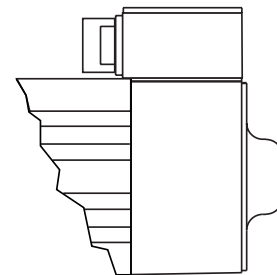

BE-40x, ME-40x

A commutation encoder for system feedback is incorporated into the BE and ME Series in place of the resolver that is used in the B and M Series. The commutation encoder includes all the data channels (A, \bar{A} , B, \bar{B} , I and \bar{I}) as well as the Hall effect channels.

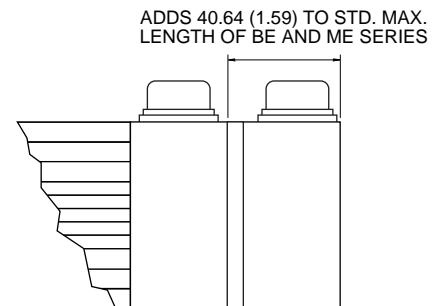

BE-40x, ME-40x BRAKE OPTION

An integral electromagnetic fail-safe brake can be added to the rear of the motor. Operating in a power off / brake on mode, the brake provides 6 lb-ft (8.0 N-m) of torque for static parking and emergency braking.

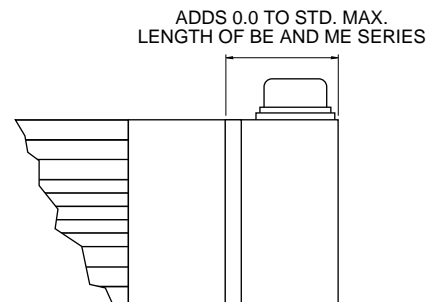

Kollmorgen GOLDLINE

60x PERFORMANCE DATA

Parameters	Symbols	Units	B-602-A	B-602-B	B-602-C	B-604-A
			BE-602-A	BE-602-B	BE-602-C	BE-604-A
			M-603-A	M-603-B	M-603-C	M-605-A
			ME-603-A	ME-603-B	ME-603-C	ME-605-A
			EB-602-A	EB-602-B	EB-602-C	EB-604-A
Horsepower	HP Rated	HP	4.4	7.7	6.1	8.0
Kilowatts	kW Rated	kW	3.3	5.7	4.6	6.0
Speed at Rated Power	N Rated	RPM	2000	4000	3000	2150
Max Operating Speed	N Max	RPM	2000	4000	3000	2150
Continuous Torque (stall) at 40°C	Tc	lb-ft	13.0	12.8	12.8	22.2
		N-m	17.6	17.4	17.4	30.1
Continuous Torque (stall) at 25°C	Tc	lb-ft	13.8	13.6	13.6	23.5
		N-m	18.7	18.4	18.4	31.9
Continuous Line Current	Ic	Amps RMS	10.0	20.0	15.0	19.0
Peak Torque	Tp	lb-ft	37.7	36.7	36.5	63.7
		N-m	51.2	49.8	49.5	86.4
Peak Line Current	Ip	Amps RMS	30.5	61.4	45.0	57.4
Max Theoretical						
Acceleration (B, BE, EB-60x) (M, ME-60x)	Z	rad / sec ²	49700	48400	48200	42500
		rad / sec ²	6590	6420	6380	6140
Torque Sensitivity (stall) ±10%	Kt	lb-ft / Amp RMS	1.30	0.63	0.85	1.17
		N-m / Amp RMS	1.77	0.85	1.15	1.59
Back EMF (line-to-line) ±10%	Kb	VRMS / kRPM	107.0	51.6	70.0	95.8
Max line-to-line Volts	VMax	Volts RMS	250	250	250	250
DC Res at 25°C						
(line-to-line) ±10%	Rm	Ohms	1.55	0.382	0.674	0.508
Inductance (line-to-line) ±30%	Lm	mh	32	9.0	14.0	13.3
Rotor Inertia (B, BE, EB-60x) (M, ME-60x)	Jm	lb-ft-sec ²	0.000758	0.000758	0.000758	0.00150
		kg-m ²	0.001028	0.001028	0.0001028	0.002034
		lb-ft-sec ²	0.00572	0.00572	0.00572	0.01037
		kg-m ²	0.00775	0.00775	0.00775	0.01406
Weight (B, BE-60x) (M, ME-60x) (EB-60x)	Wt	lb	37.0	37.0	37.0	51.0
		kg	16.8	16.8	16.8	23.1
	Wt	lb	44	44	44	63
		kg	20	20	20	28.7
	Wt	lb	37.0	37.0	37.0	51.0
		kg	16.8	16.8	16.8	23.1
Static Friction	Tf	lb-ft	0.36	0.36	0.36	0.38
		N-m	0.49	0.49	0.49	0.52
Thermal Time Constant						
(B, BE, M, ME-60x)	TCT	Min	28	28	28	33
Thermal Time Constant						
(EB-60x)	TCT	Min	12	12	12	14
Viscous Damping Z Source	Fi	lb-ft / kRPM	0.053	0.053	0.053	0.080
		N-m / kRPM	0.072	0.072	0.072	0.109
Motor Constant at 25°C	Km	lb-ft / √W	0.903	0.898	0.902	1.42
		N-m / √W	1.22	1.22	1.22	1.92
Thermal Resistance at stall	Rth	°C / Watt	0.33	0.33	0.34	0.28
Number of Poles			6	6	6	6

Kollmorgen GOLDLINE

60x PERFORMANCE DATA

B-604-B	B-604-C	B-606-A	B-606-B	B-606-C	B-606-D		
BE-604-B	BE-604-C	BE-606-A	BE-606-B	BE-606-C	BE-606-D		
M-605-B	M-605-C	M-607-A	M-607-B	M-607-C	M-607-D		
ME-605-B	ME-605-C	ME-607-A	ME-607-B	ME-607-C	ME-607-D		
EB-604-B	EB-604-C	EB-606-A	EB-606-B	EB-606-C	EB-606-D	Units	Symbols
10.4	11.5	8.8	15.0	14.2	11.0	HP	HP Rated
7.7	8.6	6.6	11.2	10.6	8.2	kW	kW Rated
3150	4300	1550	3050	4150	2300	RPM	N Rated
3150	4300	1550	3050	4150	2300	RPM	N Max
22.2	23.0	33.0	31.0	33.0	31.0	lb-ft	Tc (at 40°C)
30.1	31.2	44.8	42.0	44.8	42.0	N-m	
23.5	24.4	35.0	32.9	35.0	32.9	lb-ft	Tc (at 25°C)
31.8	33.6	47.5	44.6	47.5	44.6	N-m	
27.7	39.4	20.0	37.5	54.8	28.0	Amps RMS	Ic
64.7	63.7	97.2	93.0	91.6	90.4	lb-ft	Tp
87.7	86.4	132.0	126.0	124.0	123.0	N-m	
84.8	114.8	62.0	118.6	160.0	86.2	Amps RMS	Ip
43100	42500	43400	41500	40900	40400	rad / sec ²	Z (B, BE, EB-60x)
6240	6140	6220	5960	5870	5790	rad / sec ²	Z (M, ME-60x)
0.80	0.58	1.65	0.83	0.60	1.1	lb-ft / Amp RMS	Kt
1.09	0.79	2.24	1.12	0.82	1.2	N-m / Amp RMS	
65.9	47.9	135.0	67.7	49.5	90.5	VRMS / kRPM	Kb
250	250	250	250	250	250	Volts RMS	VMax
0.234	0.126	0.500	0.140	0.076	0.26	Ohms	Rm
6.3	3.3	15.6	3.8	2.1	7.0	mh	Lm
0.001500	0.001500	0.00224	0.00224	0.00224	0.00224	lb-ft-sec ²	Jm (B, BE, EB-60x)
0.002034	0.002034	0.00304	0.00304	0.00304	0.00304	kg-m ²	
0.01037	0.01037	0.01561	0.01561	0.01561	0.01561	lb-ft-sec ²	Jm (M, ME-60x)
0.01406	0.01406	0.02117	0.02117	0.02117	0.02117	kg-m ²	
51.0	51.0	66	66	66	66	lb	Wt (B, BE-60x)
23.1	23.1	29.9	29.9	29.9	29.9	kg	
63	63	83	83	83	83	lb	Wt (M, ME-60x)
28.7	28.7	37.8	37.8	37.8	37.8	kg	
51.0	51.0	66.0	66.0	66.0	66.0	lb	Wt (EB-60x)
23.1	23.1	29.9	29.9	29.9	29.9	kg	
0.38	0.38	0.694	0.694	0.694	0.694	lb-ft	Tf
0.52	0.52	0.941	0.941	0.941	0.941	N-m	
33	33	38	38	38	38	Min	TCT (B, BE, M, ME-60x)
14	14	16	16	16	16	Min	TCT (EB-60x)
0.080	0.080	0.108	0.108	0.108	0.108	lb-ft / kRPM	Fi
0.109	0.109	0.147	0.147	0.147	0.147	N-m / kRPM	
1.43	1.42	2.02	1.91	1.89	1.88	lb-ft / \sqrt{W}	Km (at 25°C)
1.94	1.93	2.74	2.59	2.57	2.55	N-m / \sqrt{W}	
0.28	0.26	0.26	0.26	0.22	0.25	°C / Watt	Rth
6	6	6	6	6	6	Number of Poles	

Kollmorgen GOLDLINE

SYSTEM PERFORMANCE

B, EB-602-A, M-603-A with SR10
BE-602-A, ME-603-A with SE10

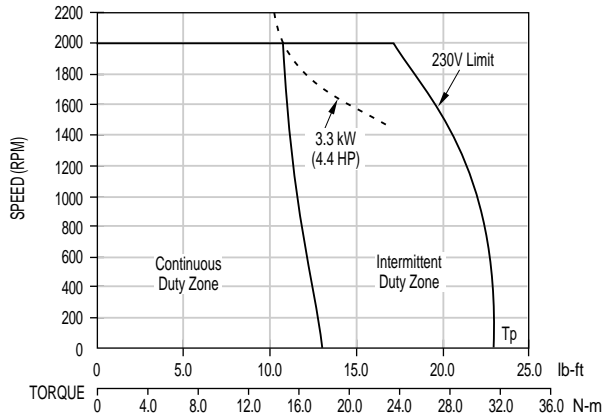

B, EB-602-B, M-603-B with SR20
BE-602-B, ME-603-B with SE20

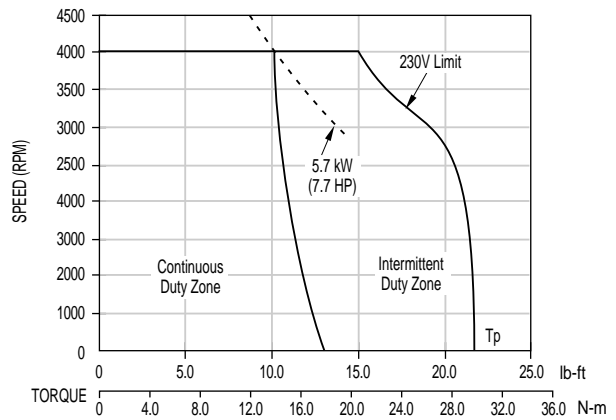

B, EB-602-C, M-603-C with SR20
BE-602-C, ME-603-C with SE20

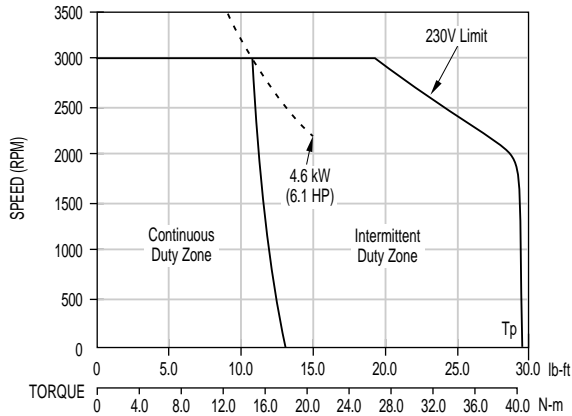

B, EB-604-A, M-605-A with SR20
BE-604-A, ME-605-A with SE20

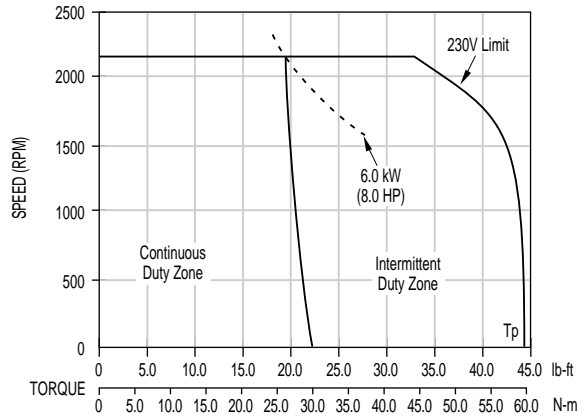

B, EB-604-B, M-605-B with SR30
BE-604-B, ME-605-B with SE30

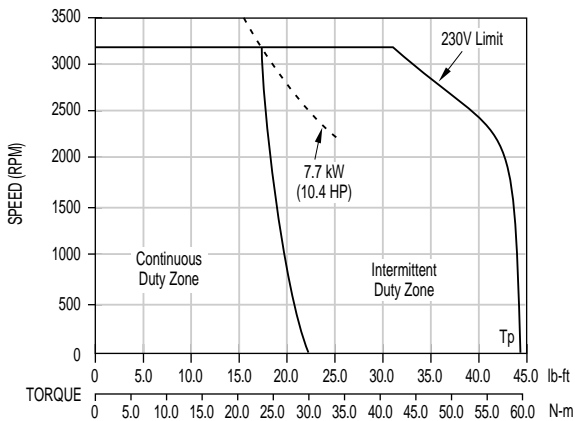

B, EB-604-C, M-605-C with SR55
BE-604-C, ME-605-C with SE55

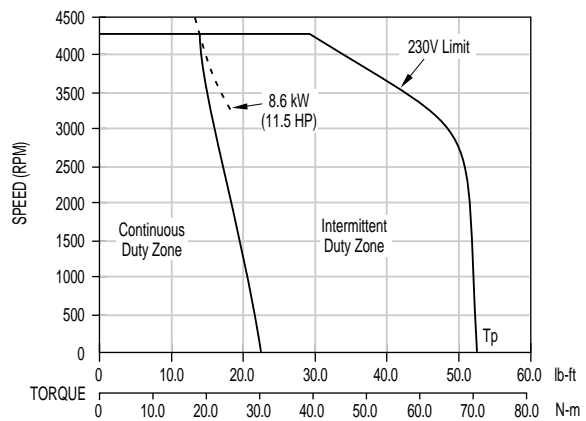

Note: Performance curves are also applicable for BDS4 and BDS5.

SYSTEM PERFORMANCE

B, EB-606-A, M-607-A with SR20
BE-606-A, ME-607-A with SE20

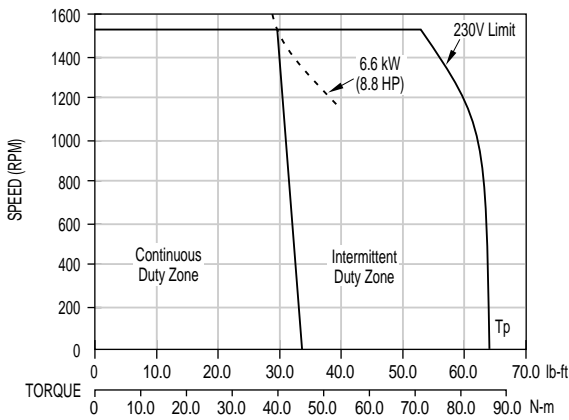

B, EB-606-B, M-607-B with SR55
BE-606-B, ME-607-B with SE55

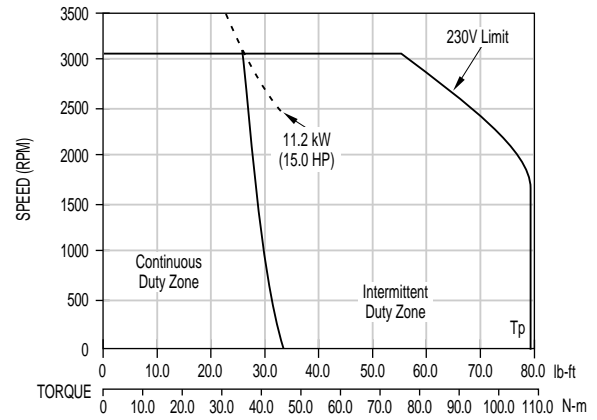

B, EB-606-C, M-607-C with SR55
BE-606-C, ME-607-C with SE55

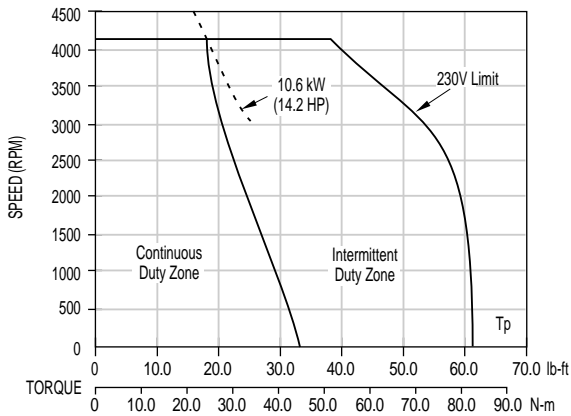

B, EB-606-D, M-607-D with SR30
BE-606-D, ME-607-D with SE30

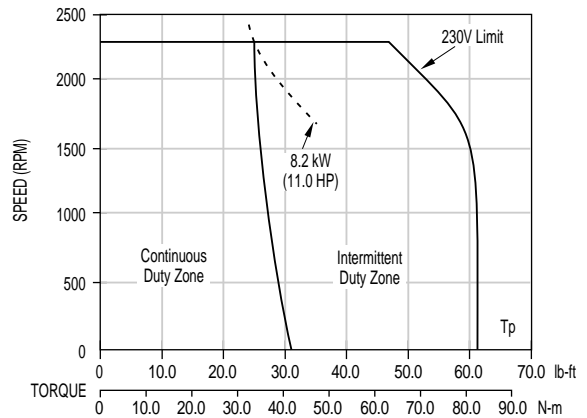

Note: Performance curves are also applicable for BDS4 and BDS5.

Kollmorgen GOLDLINE

DIMENSIONS

B, M-60x-x-A3

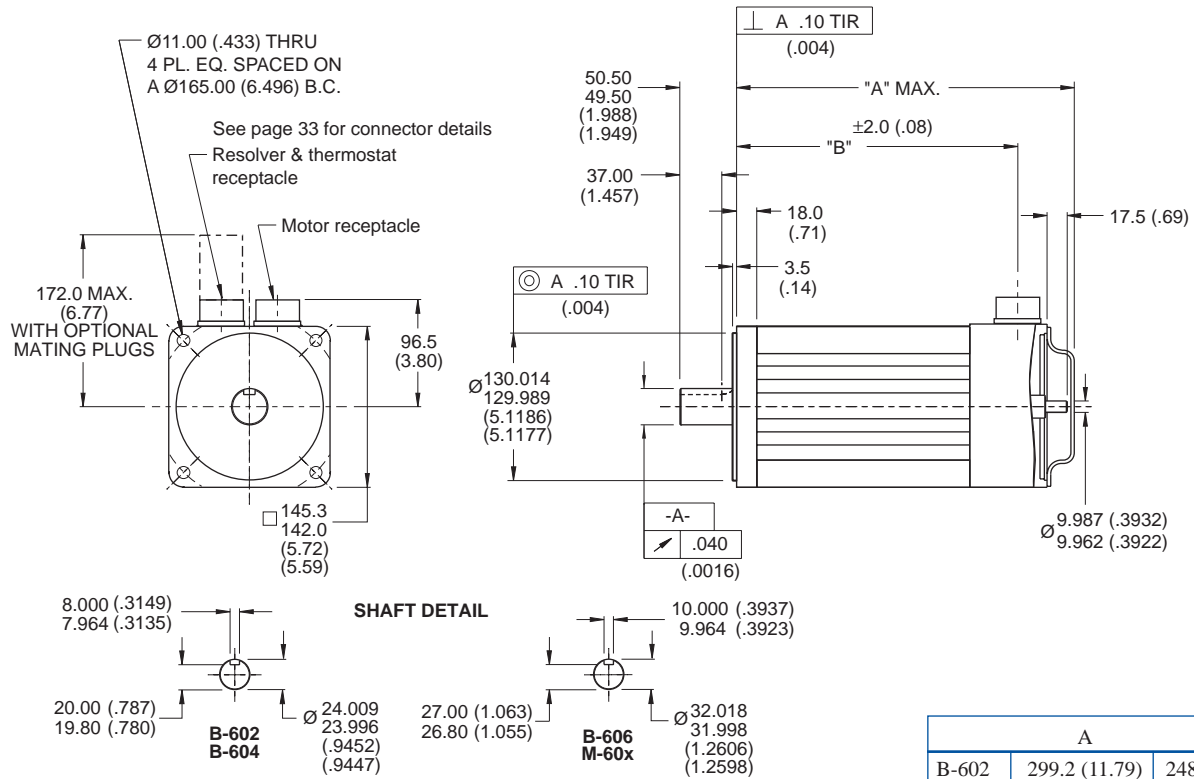

	A	B
B-602	299.2 (11.79)	248.0 (9.76)
B-604	367.8 (14.48)	316.6 (12.46)
B-606	436.4 (17.18)	385.2 (15.17)
M-603	367.8 (14.48)	316.6 (12.46)
M-605	436.4 (17.18)	385.2 (15.17)
M-607	531.5 (20.93)	480.3 (18.91)

Notes:

- BE and ME outline and dimension data and connector information is available by contacting the Kollmorgen Customer Support Network.
- Dimensions in mm (inches)
Tolerances, unless otherwise specified:
metric: X decimal place ±.4, XX decimal places ±.13
inches: XX decimal places ±.015, XXX decimal places ±.005

DIMENSIONS

EB-60x-x-11

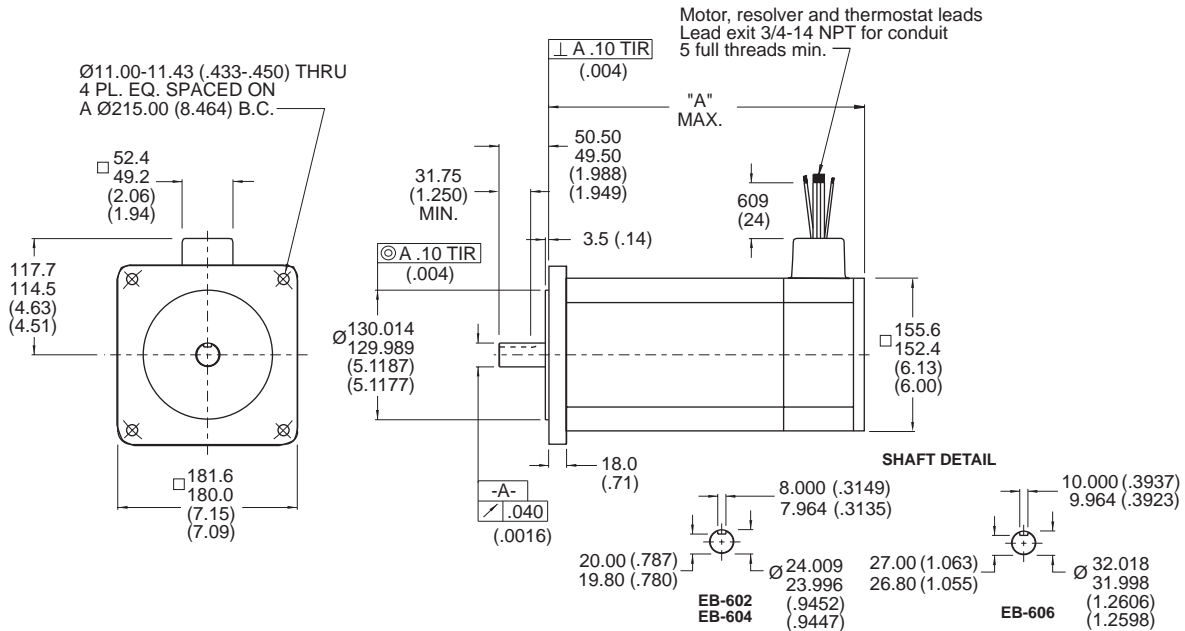

Notes:

- All lead exits potted with Chico compound #A5
- Dimensions in mm (inches)
Tolerances, unless otherwise specified:
metric: X decimal place $\pm .4$, XX decimal places $\pm .13$
inches: XX decimal places $\pm .015$, XXX decimal places $\pm .005$

A	
EB-602	327.5 (12.89)
EB-604	396.1 (15.59)
EB-606	464.7 (18.30)

FLYING LEAD AND CONNECTOR PIN OUTS

Motor Receptacle MS-3102E-22-22P Straight Mating Plug MS-3106E-22-22S	Resolver/Option Receptacle MS-3102E-22-14P Straight Mating Plug MS-3106E-22-14S	Application Resolver Receptacle MS-3102E-20-33P Optional Straight Mating Plug MS-3106E-20-33S
Pin A - Phase A (brown)	Pin A - S3 (black), Sin Hi	Pin A - S1 (red), Sin Lo
Pin B - Phase B (red)	Pin B - S1 (red), Sin Lo	Pin B - S3 (black), Sin Hi
Pin C - Phase C (white)	Pin C - S4 (blue), Cos Lo	Pin C - S2 (yellow), Cos Hi
Pin D - Ground (green with yellow stripe)	Pin D - S2 (yellow), Cos Hi	Pin D - S4 (blue), Cos Lo
	Pin E - R1 (red/white), Ref Lo	Pin E - R1 (red/white), Ref Lo
	Pin F - R2 (yellow/white), Ref Hi	Pin F - R2 (yellow/white), Ref Hi
Options	Pin T } Normally closed contacts	
Pin R } Optional brush tachometer (R-black, S-white)	Pin U } 4 Amp, 120 VAC - thermostat opens at 170°C $\pm 5^\circ\text{C}$ and closes at 132°C $\pm 5^\circ\text{C}$ (B, M-60x -- yellow leads; EB-60x -- white leads)	
Pin N } Optional DC fail-safe brake, 24 VDC or 90 VDC (blue leads)		
Pin P }		

Note: Color codes are applicable for EB-60x

Kollmorgen GOLDLINE

60x OPTIONS

B, BE-60x, M, ME-60x

Sealing

IP65 [pressure on shaft seal must not exceed 0.21 kg/cm² (3 PSI)]
 IP67 [pressure on shaft seal must not exceed 0.35 kg/cm² (5 PSI)]

Fail-safe brake

90 VDC (.39) Amps
 24 VDC (1.27) Amps
 Holding torque:
 35.0 lb-ft (48.0 N-m)
 Inertia:
 9.37 X 10⁻⁵ lb-ft-s²
 1.27 X 10⁻⁴ Kg-m²

Additional feedback

Encoders
 Resolvers

Brush-type tachometer

0.6% average/peak voltage ripple

B-60x, M-60x BRAKE OPTION

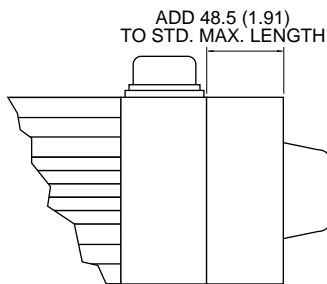

An integral electromagnetic fail-safe brake can be added to the rear of the motor. Operating in the POWER OFF/BRAKE ON mode, the brake provides 35.0 lb-ft (48.0 N-m) of torque for static parking and emergency braking.

B-60x, M-60x RESOLVER OPTION

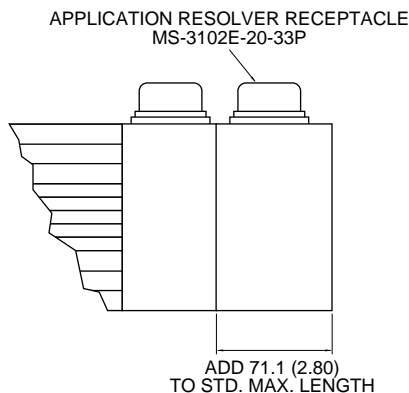

A feedback resolver option provides a direct-coupled Size 11 brushless resolver. Protected by the motor housing, a wide choice of resolvers is available to be compatible with the majority of CNC and other loop controllers.

B-60x, M-60x ENCODER OPTION

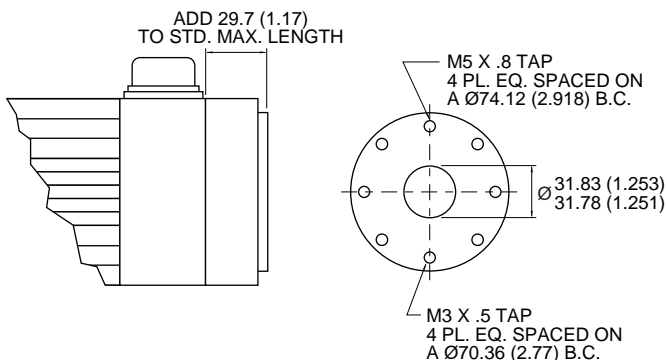

A feedback encoder adapter option provides direct coupling to a standard housed encoder. Encoder can be customer or factory supplied. Other mechanical variations are available by special request.

B-60x, M-60x TACHOMETER OPTION

An optional 0.6% average to peak voltage ripple DC tachometer is available to provide smooth speed control at extremely low speeds. It is offered in a range of sensitivities to suit particular application needs.

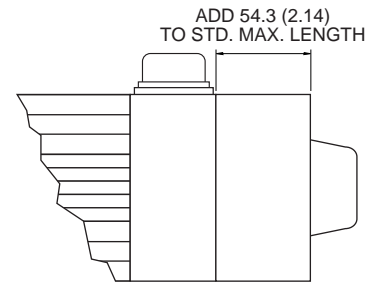

B-60x, M-60x BAYONET CONNECTOR OPTION

Bayonet type MS connectors are available along with mating plugs or factory cables to allow easy connection to Kollmorgen amplifiers.

	Motor	Resolver/Option	Application Resolver
Receptacle	CIR-020R-22-22P-F80*	MS-3122E-14-19P	MS-3122E-14-12P
Mating Plug	CIR-06F-22-22S*	MS-3116F-14-19S	MS-3116F-14-12S

* or equivalent

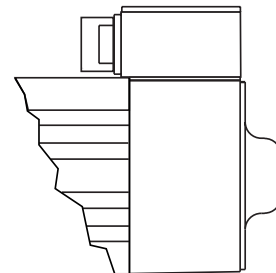

BE-60x, ME-60x

A commutation encoder for system feedback is incorporated into the BE and ME Series in place of the resolver that is used in the B and M Series. The commutation encoder includes all the data channels (A, \bar{A} , B, \bar{B} , I and \bar{I}) as well as the Hall effect channels.

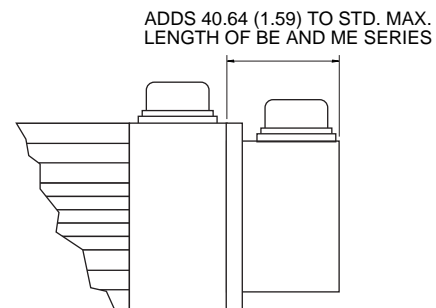

BE-60x, ME-60x BRAKE OPTION

An integral electromagnetic fail-safe brake can be added to the rear of the motor. Operating in a power off / brake on mode, the brake provides 35.0 lb-ft (48.0 N-m) of torque for static parking and emergency braking.

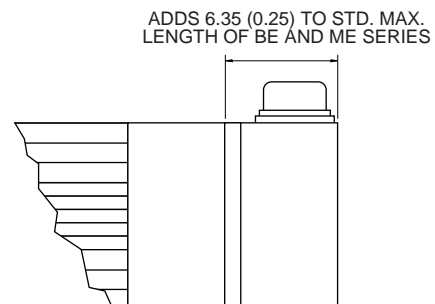

Kollmorgen GOLDLINE

80x PERFORMANCE DATA

Parameters	Symbols	Units	B-802-A	B-802-B	B-802-C	B-804-A	
			BE-802-A	BE-802-B	BE-802-C	BE-804-A	
			M-803-A	M-803-B	M-803-C	M-805-A	
			ME-803-A	ME-803-B	ME-803-C	ME-805-A	
			EB-802-A	EB-802-B	EB-802-C	EB-804-A	
Horsepower	HP Rated	HP	10.6	13.6	8.2	14.5	
Kilowatts	kW Rated	kW	7.9	10.1	6.1	10.8	
Speed at Rated Power	N Rated	RPM	2000	2750	1600	1500	
Max Operating Speed	N Max	RPM	2000	2750	1600	1500	
Continuous Torque (stall) at 40°C	Tc	lb-ft	31.0	30.0	30.0	58.0	
		N-m	42.0	40.7	40.7	78.6	
Continuous Torque (stall) at 25°C	Tc	lb-ft	32.9	31.8	31.8	61.5	
		N-m	44.6	43.1	43.1	83.4	
Continuous Line Current	Ic	Amps RMS	24.9	32.4	18.9	35.0	
Peak Torque	Tp	lb-ft	96.0	95.3	95.3	171.0	
		N-m	130.0	129.0	129.0	232.0	
Peak Line Current	Ip	Amps RMS	81.0	108.0	60.0	109	
Max Theoretical							
Acceleration (B, BE, EB-80x) (M, ME-80x)	Z	rad / sec ²	26700	26500	26500	27600	
		rad / sec ²	3710	3680	3680	3870	
Torque Sensitivity (stall) ±10%	Kt	lb-ft / Amp RMS	1.25	0.93	1.59	1.66	
		N-m / Amp RMS	1.69	1.26	2.16	2.25	
Back EMF (line-to-line) ±10%	Kb	VRMS / kRPM	102.0	76.0	130.0	136.0	
Max line-to-line Volts	VMax	Volts RMS	250	250	250	250	
DC Res at 25°C							
(line-to-line) ±10%	Rm	Ohms	0.361	0.200	0.568	0.230	
Inductance (line-to-line) ±30%	Lm	mh	16.3	9.4	25.7	13.0	
Rotor Inertia (B, BE, EB-80x) (M, ME-80x)	Jm	lb-ft-sec ²	0.00360	0.00360	0.00360	0.00620	
		kg-m ²	0.00488	0.00488	0.00488	0.00840	
		lb-ft-sec ²	0.0259	0.0259	0.0259	0.04415	
		kg-m ²	0.0352	0.0352	0.0352	0.05990	
Weight	(B, BE-80x)	Wt	lb	79	79	79	112
		kg	36	36	36	50.6	
		(M, ME-80x)	Wt	lb	96	96	96
	(EB-80x)	kg	43.7	43.7	43.7	62.8	
		Wt	lb	79	79	79	112
		kg	36	36	36	50.6	
Static Friction	Tf	lb-ft	0.47	0.47	0.47	0.67	
		N-m	0.64	0.64	0.64	0.91	
Thermal Time Constant							
(B, BE, M, ME-80x)	TCT	Min	40	40	40	48	
(EB-80x)	TCT	Min	.60	.60	.60	.70	
Viscous Damping Z Source	Fi	lb-ft / kRPM	0.175	0.175	0.175	0.221	
		N-m / kRPM	0.237	0.237	0.237	0.300	
Motor Constant at 25°C	Km	lb-ft / √W	1.79	1.79	1.82	3.00	
		N-m / √W	2.43	2.43	2.47	4.06	
Thermal Resistance at stall	Rth	°C / Watt	0.23	0.24	0.25	0.18	
Number of Poles			6	6	6	6	

Kollmorgen GOLDLINE

80x PERFORMANCE DATA

B-804-B	B-804-C	B-806-A	B-806-B	B-806-C			
BE-804-B	BE-804-C	BE-806-A	BE-806-B	BE-806-C			
M-805-B	M-805-C	M-807-A	M-807-B	M-807-C			
ME-805-B	ME-805-C	ME-807-A	ME-807-B	ME-807-C			
EB-804-B	EB-804-C	EB-806-A	EB-806-B	EB-806-C	B-808-C	Units	Symbols
18.6	21.0	20.5	21.7	12.2	20.3	HP	HP Rated
13.9	15.7	15.3	16.2	9.1	15.1	kW	kW Rated
2000	3000	1550	3000	900	1000	RPM	N Rated
2000	3000	1550	3000	900	1000	RPM	N Max
58.0	58.0	80.0	82.0	80.0	110.0	lb-ft	Tc (at 40°C)
78.6	78.6	109.0	111.0	109.0	149.0	N-m	
61.5	61.5	84.8	86.9	84.8	117.0	lb-ft	Tc (at 25°C)
83.4	83.4	115.0	117.9	115.0	158	N-m	
48.0	70.0	49.1	94.0	30.0	47.4	Amps RMS	Ic
170.0	171.0	238.0	241.0	267.0	311.0	lb-ft	Tp
230.0	232.0	323.0	327.0	362.0	422.0	N-m	
147.0	217.0	154.0	291.0	100.0	134.0	Amps RMS	Ip
27400	27600	25600	25900	28700	2510	rad / sec ²	Z (B, BE, EB-80x)
3850	3870	3630	3680	4080	N/A	rad / sec ²	Z (M, ME-80x)
1.21	0.83	1.63	0.87	2.67	2.32	lb-ft / Amp RMS	Kt
1.65	1.13	2.21	1.18	3.62	3.15	N-m / Amp RMS	
99.6	68.1	134.0	71.6	219.0	191.0	VRMS / kRPM	Kb
250	250	250	250	250	250	Volts RMS	VMax
0.129	0.058	0.130	0.034	0.340	0.168	Ohms	Rm
7.2	3.2	8.0	2.1	20.0	8.05	mh	Lm
0.00620	0.00620	0.0093	0.0093	0.0093	0.0124	lb-ft-sec ²	Jm (B, BE, EB-80x)
0.00840	0.00840	0.0126	0.0126	0.0126	0.0168	kg-m ²	
0.04415	0.04415	0.0655	0.0655	0.0655	N/A	lb-ft-sec ²	Jm (M, ME-80x)
0.05990	0.05990	0.0888	0.0888	0.0888	N/A	kg-m ²	
112	112	147	147	147	180	lb	Wt (B, BE-80x)
50.6	50.6	67	67	67	82	kg	
138	138	190	190	190	N/A	lb	Wt (M, ME-80x)
62.6	62.6	86.5	86.5	86.5	N/A	kg	
112	N/A	200	200	200	N/A	lb	Wt (EB-80x)
50.6	N/A	91	91	91	N/A	kg	
0.67	0.67	1.02	1.02	1.02	1.30	lb-ft	Tf
0.91	0.91	1.38	1.38	1.38	1.76	N-m	
48	48	55	55	55	60	Min	TCT (B, BE, M, ME-80x)
.70	.70	.80	.80	.80	N/A	Min	TCT (EB-80x)
0.221	0.221	0.267	0.267	0.267	0.264	lb-ft / kRPM	Fi
0.300	0.300	0.362	0.362	0.362	0.358	N-m / kRPM	
2.92	2.98	3.91	4.10	3.96	4.90	lb-ft / \sqrt{W}	Km (at 25°C)
3.96	4.05	5.30	5.55	5.37	6.64	N-m / \sqrt{W}	
0.17	0.18	0.16	0.17	0.17	0.14	°C / Watt	Rth
6	6	6	6	6	6	Number of Poles	

Kollmorgen GOLDLINE

SYSTEM PERFORMANCE

B, EB-802-A, M-803-A with SR30
BE-802-A, ME-803-A with SE30

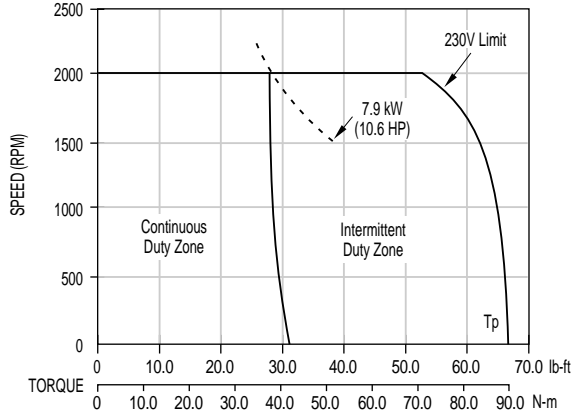

B, EB-802-B, M-803-B with SR55
BE-802-B, ME-803-B with SE55

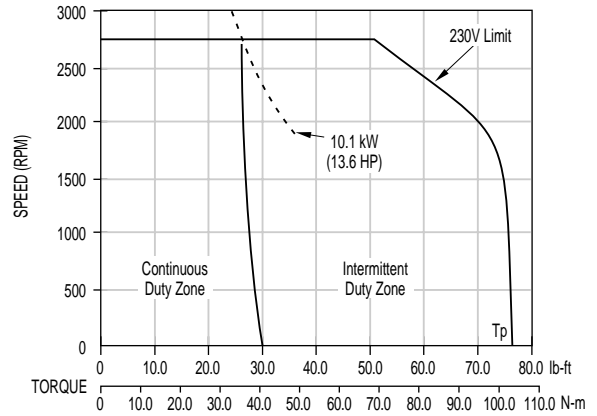

B, EB-804-A, M-805-A with SR55
BE-804-A, ME-805-A with SE55

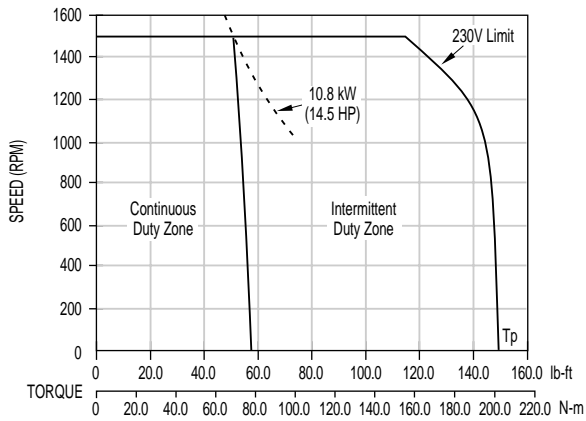

B, EB-804-B, M-805-B with SR55
BE-804-B, ME-805-B with SE55

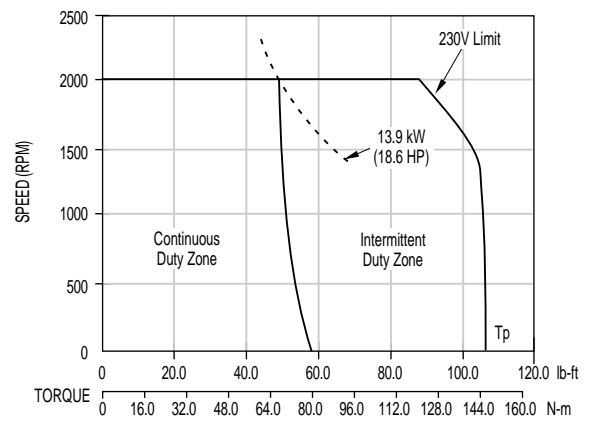

B, EB-804-C, M-805-C with SR55
BE-804-C, ME-805-C with SE55

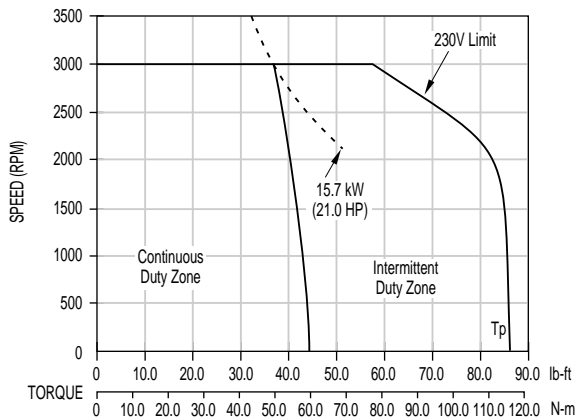

B, EB-804-C, M-805-C with SR85
BE-804-C, ME-805-C with SE85

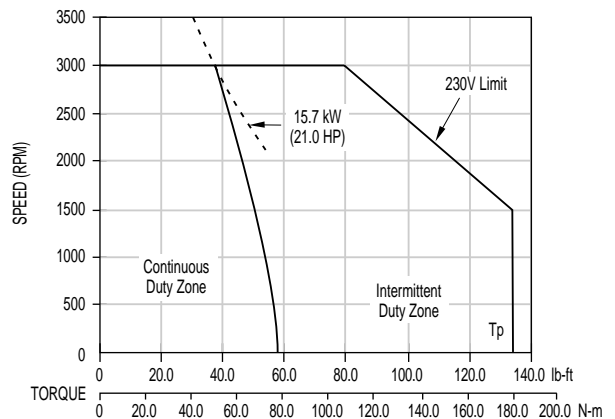

SYSTEM PERFORMANCE

B, EB-806-A, M-807-A with SR55
BE-806-A, ME-807-A with SE55

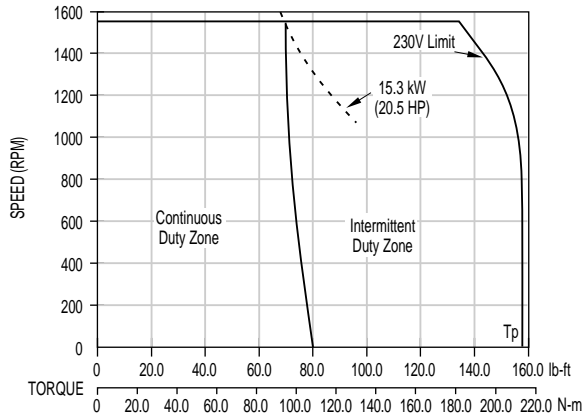

B, EB-806-B, M-807-B with SR85
BE-806-B, ME-807-B with SE85

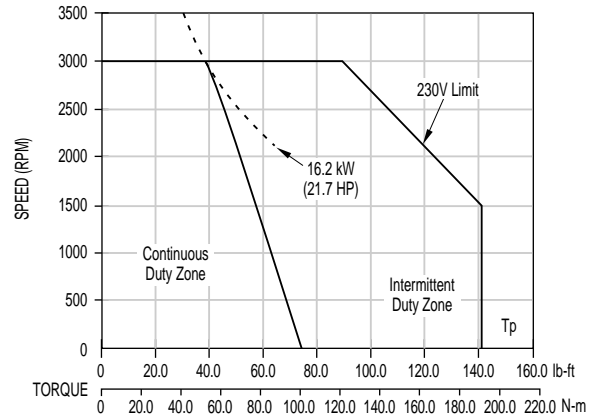

B, EB-806-C, M-807-C with SR30
BE-806-C, ME-807-C with SE30

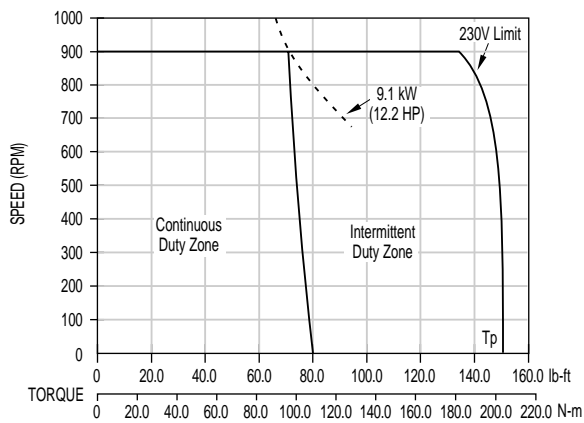

B-808-C with SR55

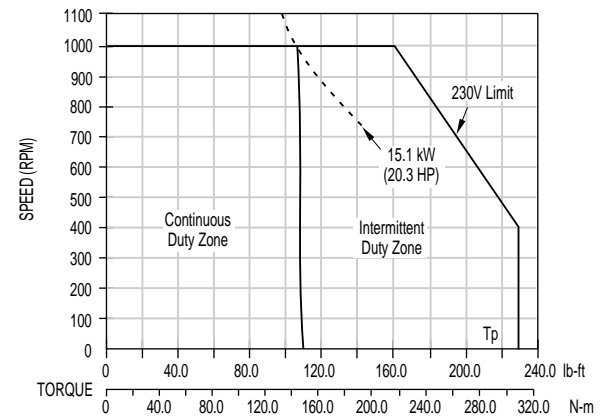

Kollmorgen GOLDLINE

DIMENSIONS

B, M-80x-x-A3

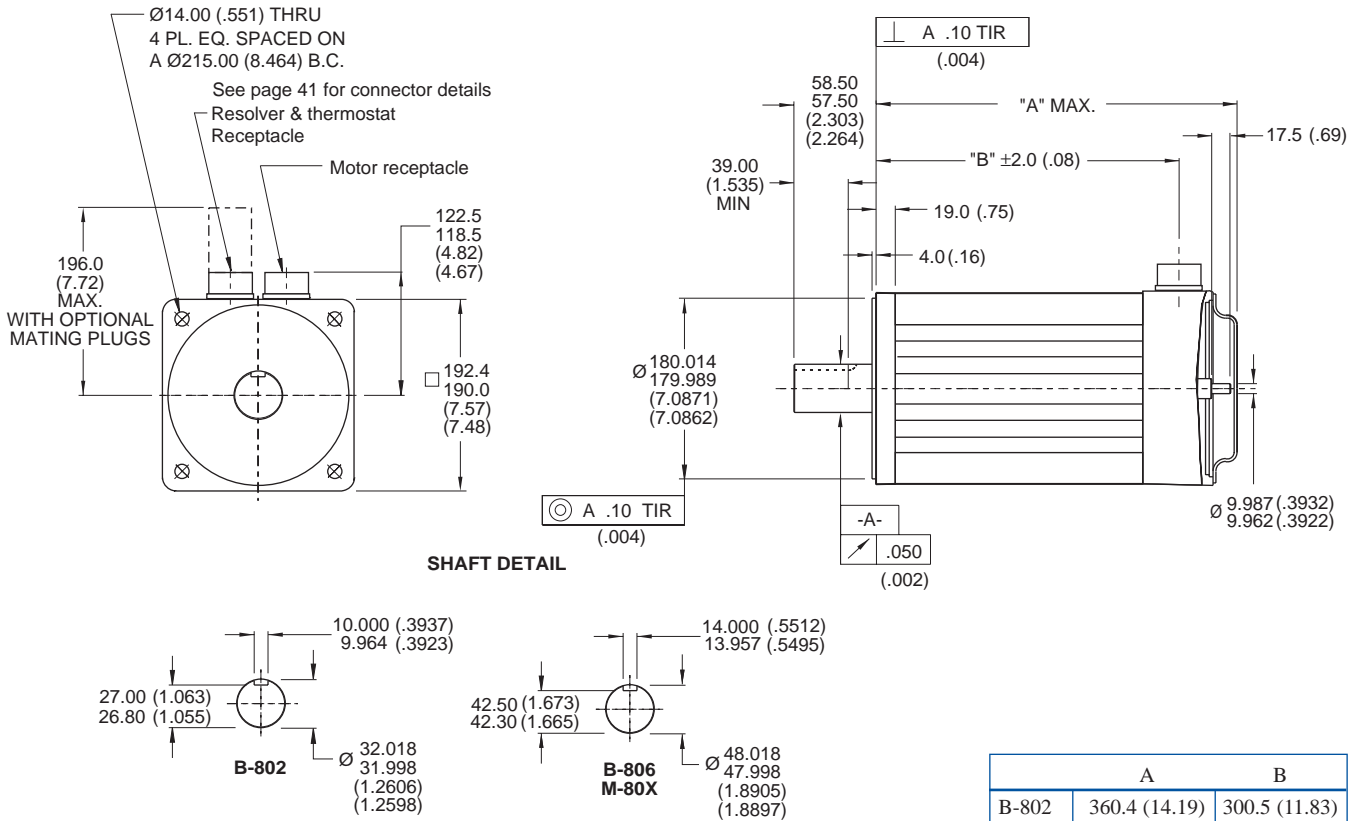

Notes:

- BE and ME outline and dimension data and connector information is available by contacting the Kollmorgen Customer Support Network.
- Dimensions in mm (inches)
 Tolerances, unless otherwise specified:
 metric: X decimal place $\pm .4$, XX decimal places $\pm .13$
 inches: XX decimal places $\pm .015$, XXX decimal places $\pm .005$

	A	B
B-802	360.4 (14.19)	300.5 (11.83)
B-804	449.9 (17.71)	390.0 (15.35)
B-806	539.4 (21.24)	479.5 (18.88)
B-808	628.9 (24.76)	569.0 (22.40)
M-803	449.9 (17.71)	390.0 (15.35)
M-805	539.4 (21.24)	479.5 (18.88)
M-807	648.7 (25.54)	588.8 (23.18)

DIMENSIONS

EB-80x-x-11

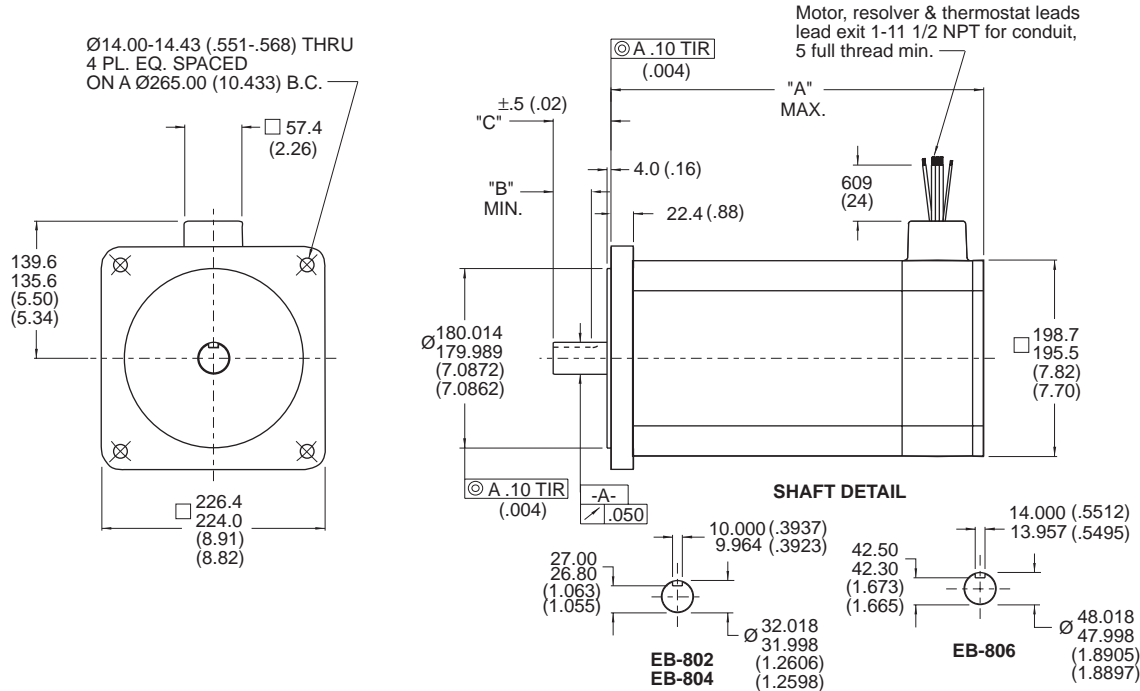

Notes:

- All lead exits potted with Chico compound #A5
- Dimensions in mm (inches)
Tolerances, unless otherwise specified:
metric: X decimal place ±.4, XX decimal places ±.13
inches: XX decimal places ±.015, XXX decimal places ±.005

	A	B	C
EB-802	384.3 (15.13)	37.6 (1.480)	58.0 (2.283)
EB-804	473.8 (18.65)	37.6 (1.480)	58.0 (2.283)
EB-806	563.3 (22.18)	54.0 (2.126)	82.0 (3.228)

FLYING LEAD AND CONNECTOR PIN OUTS

Motor Receptacle MS 3102E-22-22P Straight Mating Plug MS 3106E-22-22S	Resolver/Option Receptacle MS 3102E-22-14P Straight Mating Plug MS 3106E-22-14S	Application Resolver Receptacle MS 3102E-20-33P Optional Straight Mating Plug MS-3106E-20-33S
Pin A - Phase A (brown)	Pin A - S3 (black), Sin Hi	Pin A - S1 (red), Sin Lo
Pin B - Phase B (red)	Pin B - S1 (red), Sin Lo	Pin B - S3 (black), Sin Hi
Pin C - Phase C (white)	Pin C - S4 (blue), Cos Lo	Pin C - S2 (yellow), Cos Hi
Pin D - Ground (green with yellow stripe)	Pin D - S2 (yellow), Cos Hi	Pin D - S4 (blue), Cos Lo
	Pin E - R1 (red/white), Ref Hi	Pin E - R1 (red/white), Ref Hi
	Pin F - R2 (yellow/white), Ref Lo	Pin F - R2 (yellow/white), Ref Lo
Options	Pin T } Normally closed contacts	
Pin R } Optional brush tachometer (R-black, S-white)	Pin U } 4 Amp, 120 VAC - thermostat opens at 170°C ±5°C and closes at 132°C ±5°C (B, M-80x -- black leads; EB-80x -- white leads)	
Pin N } Optional DC fail-safe brake, 24 VDC or 90 VDC (blue leads)		
Pin P }		

Note: Color codes are applicable for EB-80x

Kollmorgen GOLDLINE

80x OPTIONS

B, BE-80x, M, ME-80x

Sealing

IP65 [pressure on shaft seal must not exceed 0.21

kg/cm² (3 PSI)]

IP67 [pressure on shaft seal must not exceed 0.35

kg/cm² (5 PSI)]

Fail-safe brake

90 VDC (.39) Amps

24 VDC (1.27) Amps

Holding torque:

35.0 lb-ft (48.0 N-m)

Inertia:

9.37 X 10⁻⁵ lb-ft-s²

1.27 X 10⁻⁴ Kg-m²

Additional feedback

Encoders

Resolvers

Brush-type tachometer

0.6% average/peak voltage ripple

B-80x, M-80x BRAKE OPTION

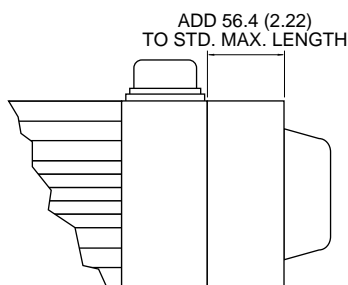

An integral electromagnetic fail-safe brake can be added to the rear of the motor. Operating in the POWER OFF/BRAKE ON mode, the brake provides 35.0 lb-ft (48.0 N-m) of torque for static parking and emergency braking.

B-80x, M-80x RESOLVER OPTION

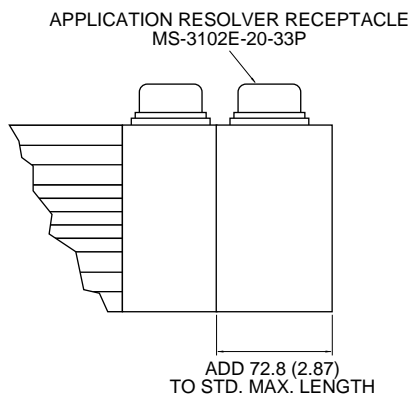

A feedback resolver option provides a direct-coupled Size 11 brushless resolver. Protected by the motor housing, a wide choice of resolvers is available to be compatible with the majority of CNC and other loop controllers.

B-80x, M-80x ENCODER OPTION

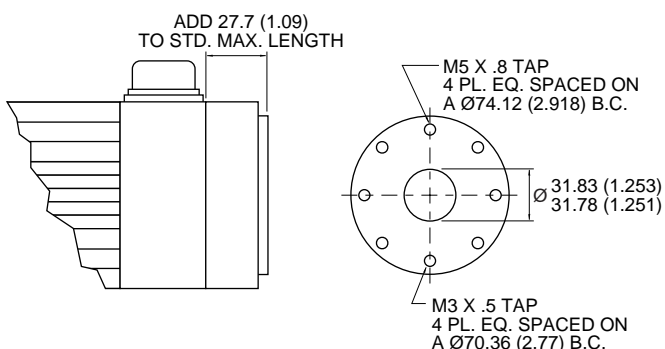

A feedback encoder adapter option provides direct coupling to a standard housed encoder. Encoder can be customer or factory supplied. Other mechanical variations are available by special request.

B-80x, M-80x TACHOMETER OPTION

An optional 0.6% average to peak voltage ripple DC tachometer is available to provide smooth speed control at extremely low speeds. It is offered in a range of sensitivities to suit particular application needs.

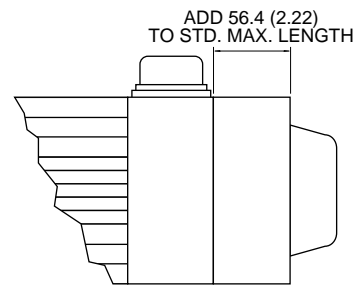

B-80x, M-80x BAYONET CONNECTOR OPTION

Bayonet type MS connectors are available along with mating plugs or factory cables to allow easy connection to Kollmorgen amplifiers.

	Motor	Resolver/Option	Application Resolver
Receptacle	CIR-020R-32-17P*	MS-3122E-14-19P	MS-3122E-14-12P
Mating Plug	CIR-06F-32-17S*	MS-3116F-14-19S	MS-3116F-14-12S

* or equivalent

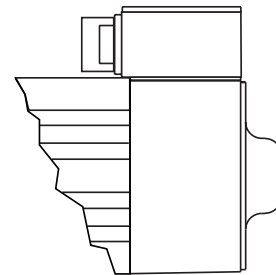

BE-80x, ME-80x

A commutation encoder for system feedback is incorporated into the BE and ME Series in place of the resolver that is used in the B and M Series. The commutation encoder includes all the data channels (A, \bar{A} , B, \bar{B} , I and \bar{I}) as well as the Hall effect channels.

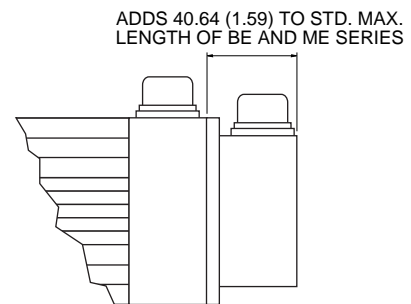

BE-80x, ME-80x BRAKE OPTION

An integral electromagnetic fail-safe brake can be added to the rear of the motor. Operating in a power off / brake on mode, the brake provides 35 lb-ft (48 N-m) of torque for static parking and emergency braking.

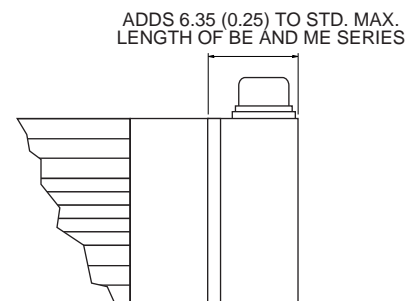

Kollmorgen GOLDLINE

ORDERING INFORMATION

B, M Series

B - 80 2 x - A x - A 3 B231^a - 100^b

Brushless Motor
(With frameless resolver)
B-Low Inertia Series
M-Medium Inertia Series

Motor Frame
10, 20, 40, 60, 80

Stack Length
2, 4, 6 - B Series
3, 5, 7 - M Series

S - Non-UL recognized models only

Winding
A, B, etc.

Optional Brush Tachometer Winding
A, B, etc.

Connection Option:

Screw Thread Connectors (standard)

Mounted on motor at a 90° orientation: B-40x, B-60x, and B-80x only

A - Connectors, less mating plugs

B - Connectors, with mating plugs

x - Terminal box for ratings > 55 A

(consult Kollmorgen Customer Support Network)

Flying Lead

B-10x and B-20x only

1 - Unterminated, 457 mm (18.0 in) minimum length

Bayonet Connectors (standard 10x)

motor and resolver / option connectors mounted parallel to motor

2 - Connectors, less mating plugs

3 - Connectors, with mating plugs

Other specials

9 - See sequential specials

Sequential Specials

Standard Additions

B2 - 90 VDC fail-safe brake

B3 - 24 VDC fail-safe brake

B9 - Special brake

(See sequential specials)

T - Brush tachometer (not avail. B-10x)

E1 - Encoder adapter (std. less encoder)

Exx - Std. encoder

Exxx - Special adapter and/or encoder

R1 - Resolver adapter (std. less resolver)

Rxx - Standard resolver

Rxxx - Special adapter and/or receiver

S - IP67 sealing (Viton) available only with -1 and -2 mounting and shaft seal option

P - In-line planetary gearhead.

See pg. 52 for details.

Mounting and Shaft Seal Options:

1 - Std. metric mount with IP65 sealing

and rear shaft extension

2 - Same as 1, except w/o rear shaft extension

3 - Same as 1, except w/o front shaft seal

4 - Same as 2, except w/o front shaft seal

9 - Special (See sequential specials)

^a Omit when no standard additions are used

^b Omit if not special

EB Series

EB - 20 4 - A - 1 1 - B2

UL Explosion-Proof Brushless Motor

Motor Frame
10, 20, 40, 60 and 80

Stack Length
2, 4 and 6

Winding
A, B, etc.

Standard Additions:

B2 - 90 VDC fail-safe brake

B3 - 24 VDC fail-safe brake

(omit if no brake)

Mounting Option

1 - standard metric mount

no rear shaft extension

Connection Option

1 - flying leads, 609 mm

3/4 - 14 NPT for conduit

ORDERING INFORMATION

BE, ME Series

BE 2 - 20 4 x - A - A 4 - B2SP4C^a - 001^b

Brushless Motor

(with commutation encoder)
B-Low Inertia Series
M-Medium Inertia Series

Encoder Resolution

1 - 1024 LPR (7500 RPM Limit)
2 - 2048 LPR (6000 RPM Limit)

Motor Frame

10, 20, 40, 60 and 80

Stack Length

2, 4, 6 - B Series
3, 5, 7 - M Series

S - Non-UL recognized models only

Winding

A, B, etc.

Connector Option:

Screw Thread Connectors (standard 20x thru 80x)

A - Connectors, less mating plugs
B - Connectors, with mating plugs
x - Terminal box for ratings >55A consult the
Kollmorgen Customer Support Network

Bayonet Connectors (standard 10x)

2 - Connectors, less mating plugs
3 - Connectors, with mating plugs

Other Specials

9 - See sequential specials

Sequential Specials

Standard Additions

B2 - 90 VDC fail-safe brake
B3 - 24 VDC fail-safe brake
B9 - Special brake
(See sequential specials)
S - IP67 Sealing, Viton O Ring
and shaft seal
P - In-line planetary gearhead
See pg. 52 for details.

Mounting and Shaft Seal

2 - Std metric mount, no rear shaft ext,
shaft seal
4 - Std metric mount, no rear shaft ext,
no shaft seal
9 - See sequential specials

^a Omit when no
standard additions
are used

^b Omit if not special

Note: BE and ME Series outline and dimension data is available by contacting the Kollmorgen Customer Support Network.

Kollmorgen GOLDLINE

GEARHEAD OPTION



- **2.0 to 2549 N-m (1.5 to 1880 lb-ft) Continuous Stall Torque**
- **For B, BE, M and ME Series Motors**
- **Standard Ratios 3, 5, 10, 20, 50 and 100**
- **As Low as 3 Arc Minute Backlash**

Kollmorgen **GOLDLINE** Gearheads for B, BE, M and ME Series Motors mount directly to the motor shaft. Available in multiple ratios, the gearheads multiply the motor's output torque leveraging the high-speed capabilities of Kollmorgen servomotors.

Higher Bandwidth

More stable operation for large loads. Reduces the effective inertia of the load at the motor.

Precise Positioning

Facilitates more precise positioning of the load by multiplying the servo positioning resolution.

Multiple Ratios

Provides flexibility to select the optimum, cost-effective product.

One Vendor Solution

Eliminates the need for the customer to separately size and procure a gearhead.

Low Backlash

Down to 3 arc minutes allows very accurate positioning.

Small Package/High-Torsional Stiffness

Gearhead mounts directly to the motor's shaft. Fits into a tight space.

High Reliability

Long lasting, shrink disk coupling connects motor to gearhead.

Long Life

Both single and double stage gearheads contain only planetary gears.

- A totally self-lubricating (grease) system
- Input stage shares the torque across three gears, not one
- Reduces motor and gearhead bearing load

Cost Effective Solution for Low Speed, High-Torque Applications

Right-Angle Gearheads Available

(Consult the Kollmorgen Customer Support Network)

DIMENSIONS

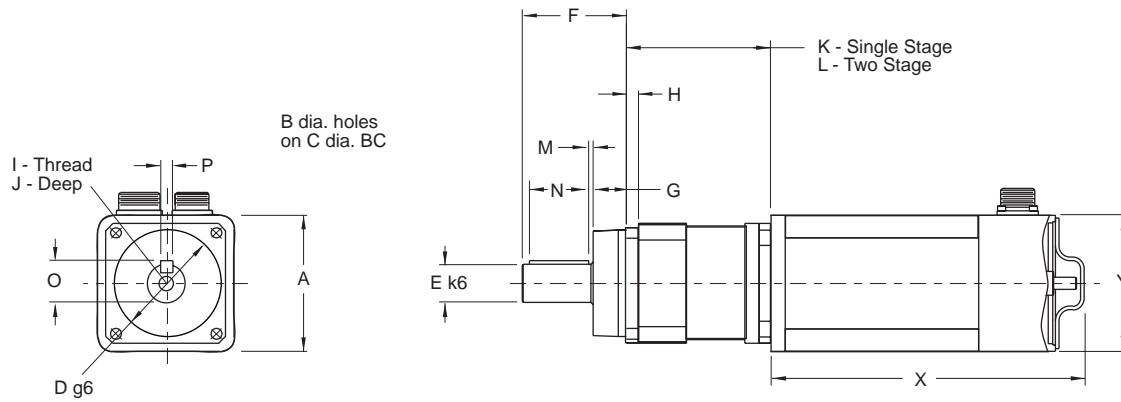

Reducer Model

	Size 1		Size 2		Size 3		Size 4		Size 5	
	in	mm	in	mm	in	mm	in	mm	in	mm
A	2.4	61	2.95	75	3.98	101	5.55	141	7.17	182
B	0.22	5.6	0.28	7	0.35	9	0.43	11	0.53	13.5
C	2.68	68	3.35	85	4.72	120	6.496	165	8.46	215
D	2.3622	60	2.7559	70	3.5433	90	5.1181	130	6.2987	160
E	0.6299	16	0.8661	22	1.2598	32	1.5748	40	2.1654	55
F	1.89	48	2.2	56	3.46	88	4.41	112	4.41	112
G (pilot width)	0.71	18	0.77	19.5	1.1	28	1.06	27	1.06	27
H	0.28	7	0.31	8	0.39	10	0.5	13	0.59	15
I	N/A	M5	N/A	M8	N/A	M12	N/A	M12	N/A	M20
J	0.75	19	0.75	19	0.8	20	0.8	20	1.65	42
K (max)	3.75	95.3	5.17	131.3	4.78	121.4	6.41	162.8	8.06	204.7
L (max)	4.63	117.6	6.04	153.4	6.04	153.4	8.14	206.8	10.54	267.7
M	0.04	1	0.04	1	0.08	2	0.118	3	0.12	3
N	0.98	25	1.26	32	1.97	50	2.76	70	2.76	70
O	0.709	18	0.965	24.5	1.38	35	1.693	43	2.32	59
P (sq)	0.197	5	0.236	6	0.394	10	0.472	12	0.6299	16
X	These dimensions will vary with the type of motor selected.									
Y	Consult the appropriate Kollmorgen GOLDLINE motor section for exact motor dimensions.									

Kollmorgen GOLDLINE

PERFORMANCE DATA

Motor Models	Gearmotor Data	Reducer Ratio XX/1		
		3	5	10
	Gearhead Size	1	1	1
B-102-A	Tc (lb-ft / N-m)	1.54 / 2.09	2.57 / 3.48	5.13 / 6.96
BE-102-A	Tp (lb-ft / N-m)	4.05 / 5.49	6.75 / 9.15	13.5 / 18.3
M-103-A	N Max (RPM)	1667	1000	500
ME-103-A	(B-102-A Jgm x 10 ⁴ (lb-ft-sec ² /kg-m ²))	0.420 / 0.57	0.309 / 0.419	0.287 / 0.389
EB-102-A	(M-103-A Jgm x 10 ⁴ (lb-ft-sec ² /kg-m ²))	1.755 / 2.38	1.645 / 2.23	1.623 / 2.200
	Gearhead Size	1	1	1
B-104-A	Tc (lb-ft / N-m)	3.00 / 4.06	5.00 / 6.77	9.99 / 13.5
BE-104-A	Tp (lb-ft / N-m)	7.88 / 10.7	13.1 / 17.8	26.3 / 35.6
M-105-A	N Max (RPM)	1667	1000	500
ME-105-A	(B-104-A Jgm x 10 ⁴ (lb-ft-sec ² /kg-m ²))	0.532 / 0.721	0.421 / 0.571	0.399 / 0.541
EB-104-A	(M-105-A Jgm x 10 ⁴ (lb-ft-sec ² /kg-m ²))	2.685 / 3.64	2.574 / 3.49	2.552 / 3.460
	Gearhead Size	1	1	1
B-106-A	Tc (lb-ft / N-m)	4.37 / 5.93	7.29 / 9.88	14.6 / 19.8
BE-106-A	Tp (lb-ft / N-m)	8.32 / 11.3	13.9 / 18.8	27.7 / 37.6
M-107-A	N Max (RPM)	1400	840	420
ME-107-A	(B-106-A Jgm x 10 ⁴ (lb-ft-sec ² /kg-m ²))	0.756 / 1.03	0.645 / 0.875	0.623 / 0.845
EB-106-A	(M-107-A Jgm x 10 ⁴ (lb-ft-sec ² /kg-m ²))	4.175 / 5.66	4.064 / 5.510	4.042 / 5.480
	Gearhead Size	2	2	2
B-202-B	Tc (lb-ft / N-m)	4.86 / 6.59	8.10 / 11.0	16.2 / 22.0
BE-202-B	Tp (lb-ft / N-m)	9.18 / 12.4	15.3 / 20.7	30.6 / 41.5
M-203-B	N Max (RPM)	1267	760	380
ME-203-B	(B-202-A Jgm x 10 ⁴ (lb-ft-sec ² /kg-m ²))	1.10 / 1.50	0.971 / 1.32	0.904 / 1.23
EB-202-B	(M-203-A Jgm x 10 ⁴ (lb-ft-sec ² /kg-m ²))	6.53 / 8.86	6.402 / 8.68	6.336 / 8.59
	Gearhead Size	2	2	3
B-204-B	Tc (lb-ft / N-m)	8.26 / 11.2	13.8 / 18.7	27.5 / 37.3
BE-204-B	Tp (lb-ft / N-m)	20.0 / 27.1	33.3 / 45.1	66.6 / 90.3
M-205-B	N Max (RPM)	1200	720	360
ME-205-B	(B-204-A Jgm x 10 ⁴ (lb-ft-sec ² /kg-m ²))	1.64 / 2.23	1.51 / 2.05	2.09 / 2.83
EB-204-B	(M-205-A Jgm x 10 ⁴ (lb-ft-sec ² /kg-m ²))	8.80 / 11.93	8.67 / 11.75	9.24 / 12.53
	Gearhead Size	2	2	3
B-206-B	Tc (lb-ft / N-m)	12.7 / 17.2	21.1 / 28.6	* 29.5 / 40.0 *
BE-206-B	Tp (lb-ft / N-m)	25.9 / 35.1	43.2 / 58.6	86.4 / 117
M-207-B	N Max (RPM)	933	560	280
ME-207-B	(B-206-A Jgm x 10 ⁴ (lb-ft-sec ² /kg-m ²))	2.22 / 3.01	2.09 / 2.83	2.66 / 3.61
EB-206-B	(M-207-A Jgm x 10 ⁴ (lb-ft-sec ² /kg-m ²))	13.65 / 18.50	13.51 / 18.32	14.09 / 19.10
	Gearhead Size	3	3	4
B-402-B	Tc (lb-ft / N-m)	13.7 / 18.6	22.8 / 31.0	45.7 / 61.9
BE-402-B	Tp (lb-ft / N-m)	26.3 / 35.7	43.9 / 59.5	87.8 / 119
M-403-B	N Max (RPM)	1000	600	300
ME-403-B	(B-402-A Jgm x 10 ⁴ (lb-ft-sec ² /kg-m ²))	4.89 / 6.63	3.56 / 4.83	4.52 / 6.13
EB-402-B	(M-403-A Jgm x 10 ⁴ (lb-ft-sec ² /kg-m ²))	21.61 / 29.3	20.28 / 27.5	21.24 / 28.8
	Gearhead Size	3	3	4
B-404-B	Tc (lb-ft / N-m)	25.5 / 34.6	42.5 / 57.7	* 70.1 / 95.0 *
BE-404-B	Tp (lb-ft / N-m)	51.3 / 69.6	85.5 / 116	171.0 / 231.8
M-405-B	N Max (RPM)	833	500	250
ME-405-B	(B-404-A Jgm x 10 ⁴ (lb-ft-sec ² /kg-m ²))	7.35 / 9.96	6.02 / 8.16	6.98 / 9.46
EB-404-B	(M-405-A Jgm x 10 ⁴ (lb-ft-sec ² /kg-m ²))	35.03 / 47.5	33.71 / 45.7	34.67 / 47
	Gearhead Size	3	3	4
B-406-B	Tc (lb-ft / N-m)	32.8 / 44.4	54.6 / 74.1	* 70.1 / 95.0 *
BE-406-B	Tp (lb-ft / N-m)	76.4 / 104	127 / 173	255 / 345
M-407-B	N Max (RPM)	1067	640	320
ME-407-B	(B-406-A Jgm x 10 ⁴ (lb-ft-sec ² /kg-m ²))	9.36 / 12.7	8.03 / 10.9	8.99 / 12.2
EB-406-B	(M-407-A Jgm x 10 ⁴ (lb-ft-sec ² /kg-m ²))	50.97 / 69.1	49.64 / 67.3	50.60 / 68.6

* Requires amplifier compensation that limits normal motor maximum performance.

Kollmorgen GOLDLINE

PERFORMANCE DATA

Motor Models	Gearmotor Data	Reducer Ratio XX/1		
		20	50	100
	Gearhead Size	1	1	2
B-102-A	Tc (lb-ft / N-m)	9.69 / 13.1	24.2 / 32.8	* 25.6 / 34.7 *
BE-102-A	Tp (lb-ft / N-m)	25.5 / 34.6	63.8 / 86.4	* 89.5 / 121 *
M-103-A	N Max (RPM)	250	100	50
ME-103-A	(B-102-A Jgm x 10 ⁴ (lb-ft-sec ² /kg-m ²))	0.32 / 0.44	0.287 / 0.389	0.375 / 0.509
EB-102-A	(M-103-A Jgm x 10 ⁴ (lb-ft-sec ² /kg-m ²))	1.66 / 2.25	1.623 / 2.200	1.711 / 2.320
	Gearhead Size	1	2	2
B-104-A	Tc (lb-ft / N-m)	18.9 / 25.6	47.2 / 64.0	* 25.6 / 34.7 *
BE-104-A	Tp (lb-ft / N-m)	49.6 / 67.3	124 / 168	* 89.5 / 121 *
M-105-A	N Max (RPM)	250	100	50
ME-105-A	(B-104-A Jgm x 10 ⁴ (lb-ft-sec ² /kg-m ²))	0.44 / 0.59	0.495 / 0.671	0.488 / 0.661
EB-104-A	(M-105-A Jgm x 10 ⁴ (lb-ft-sec ² /kg-m ²))	2.59 / 3.51	2.648 / 3.590	2.641 / 3.580
	Gearhead Size	1	2	2
B-106-A	Tc (lb-ft / N-m)	27.5 / 37.3	68.9 / 93.3	* 25.6 / 34.7 *
BE-106-A	Tp (lb-ft / N-m)	52.4 / 71.0	131 / 177	* 89.5 / 121 *
M-107-A	N Max (RPM)	210	84	42
ME-107-A	(B-106-A Jgm x 10 ⁴ (lb-ft-sec ² /kg-m ²))	0.660 / 0.895	0.719 / 0.975	0.712 / 0.965
EB-106-A	(M-107-A Jgm x 10 ⁴ (lb-ft-sec ² /kg-m ²))	4.079 / 5.530	4.138 / 5.610	4.130 / 5.600
	Gearhead Size	2	2	2
B-202-B	Tc (lb-ft / N-m)	30.6 / 41.5	77 / 104	* 25.6 / 34.7 *
BE-202-B	Tp (lb-ft / N-m)	57.8 / 78.4	145 / 196	* 89.5 / 121 *
M-203-B	N Max (RPM)	190	76	38
ME-203-B	(B-202-A Jgm x 10 ⁴ (lb-ft-sec ² /kg-m ²))	0.926 / 1.26	0.890 / 1.21	0.882 / 1.20
EB-202-B	(M-203-A Jgm x 10 ⁴ (lb-ft-sec ² /kg-m ²))	6.358 / 8.62	6.321 / 8.57	6.314 / 8.56
	Gearhead Size	2	3	3
B-204-B	Tc (lb-ft / N-m)	52.0 / 70.5	* 122 / 165 *	* 40.6 / 55.0 *
BE-204-B	Tp (lb-ft / N-m)	126 / 171	315 / 427	* 148 / 201 *
M-205-B	N Max (RPM)	180	72	36
ME-205-B	(B-204-A Jgm x 10 ⁴ (lb-ft-sec ² /kg-m ²))	1.47 / 1.99	2.01 / 2.73	2.01 / 2.73
EB-204-B	(M-205-A Jgm x 10 ⁴ (lb-ft-sec ² /kg-m ²))	8.62 / 11.69	9.17 / 12.43	9.17 / 12.43
	Gearhead Size	3	3	3
B-206-B	Tc (lb-ft / N-m)	79.7 / 108	* 122 / 165 *	* 40.6 / 55 *
BE-206-B	Tp (lb-ft / N-m)	163 / 221	361 / 490	* 148 / 201 *
M-207-B	N Max (RPM)	140	56	28
ME-207-B	(B-206-A Jgm x 10 ⁴ (lb-ft-sec ² /kg-m ²))	2.81 / 3.81	2.59 / 3.51	2.59 / 3.51
EB-206-B	(M-207-A Jgm x 10 ⁴ (lb-ft-sec ² /kg-m ²))	14.24 / 19.30	14.01 / 19.00	14.01/19.00
	Gearhead Size	3	4	4
B-402-B	Tc (lb-ft / N-m)	86 / 117	216 / 292	* 95.9 / 130 *
BE-402-B	Tp (lb-ft / N-m)	166 / 225	414 / 562	* 333 / 451 *
M-403-B	N Max (RPM)	150	60	30
ME-403-B	(B-402-A Jgm x 10 ⁴ (lb-ft-sec ² /kg-m ²))	3.34 / 4.53	4.23 / 5.73	4.23 / 5.73
EB-402-B	(M-403-A Jgm x 10 ⁴ (lb-ft-sec ² /kg-m ²))	20.06 / 27.2	20.95 / 28.4	20.95 / 28.4
	Gearhead Size	4	4	4
B-404-B	Tc (lb-ft / N-m)	161 / 218	* 291 / 395 *	* 95.9 / 130 *
BE-404-B	Tp (lb-ft / N-m)	323 / 438	808 / 1095	* 333 / 451 *
M-405-B	N Max (RPM)	125	50	25
ME-405-B	(B-404-A Jgm x 10 ⁴ (lb-ft-sec ² /kg-m ²))	7.35 / 9.96	6.68 / 9.06	6.68 / 9.06
EB-404-B	(M-405-A Jgm x 10 ⁴ (lb-ft-sec ² /kg-m ²))	35.03 / 47.5	34.37 / 46.6	34.37 / 46.6
	Gearhead Size	4	4	4
B-406-B	Tc (lb-ft / N-m)	206 / 280	* 291 / 395 *	* 95.9 / 130 *
BE-406-B	Tp (lb-ft / N-m)	481 / 652	1203 / 1631	* 333 / 451 *
M-407-B	N Max (RPM)	160	64	32
ME-407-B	(B-406-A Jgm x 10 ⁴ (lb-ft-sec ² /kg-m ²))	9.36 / 12.7	8.70 / 11.8	8.70 / 11.8
EB-406-B	(M-407-A Jgm x 10 ⁴ (lb-ft-sec ² /kg-m ²))	50.97 / 69.1	50.30 / 68.2	50.30 / 68.2

* Requires amplifier compensation that limits normal motor maximum performance.

Kollmorgen GOLDLINE

PERFORMANCE DATA

Motor Models	Gearmotor Data	Reducer Ratio XX/1		
		3	5	10
	Gearhead Size	3	3	5
B-602-B	Tc (lb-ft / N-m)	28.1 / 38.1	46.8 / 63.5	93.6 / 127
BE-602-B	Tp (lb-ft / N-m)	61.6 / 83.5	103 / 139	205 / 278
M-603-B	N Max (RPM)	1000	600	300
ME-603-B	(B-602-A Jgm x 10 ⁴ (lb-ft-sec ² /kg-m ²))	10.1 / 13.7	8.76 / 11.9	13.1 / 17.8
EB-602-B	(M-603-A Jgm x 10 ⁴ (lb-ft-sec ² /kg-m ²))	59.7 / 80.9	58.34 / 79.1	62.7 / 85.0
	Gearhead Size	4	4	5
B-604-B	Tc (lb-ft / N-m)	54.0 / 73.2	90.0 / 122	180 / 244
BE-604-B	Tp (lb-ft / N-m)	127 / 172	211 / 286	422 / 572
M-605-B	N Max (RPM)	1050	630	315
ME-605-B	(B-604-A Jgm x 10 ⁴ (lb-ft-sec ² /kg-m ²))	23.1 / 31.3	18.6 / 25.2	20.5 / 27.8
EB-604-B	(M-605-A Jgm x 10 ⁴ (lb-ft-sec ² /kg-m ²))	111.8 / 151.6	107.3 / 145.5	109.2 / 148.1
	Gearhead Size	4	4	5
B-606-B	Tc (lb-ft / N-m)	70.2 / 95.2	117 / 159	234 / 317
BE-606-B	Tp (lb-ft / N-m)	174 / 236	290 / 394	581 / 787
M-607-B	N Max (RPM)	1017	610	305
ME-607-B	(B-606-A Jgm x 10 ⁴ (lb-ft-sec ² /kg-m ²))	30.5 / 41.4	26.0 / 35.3	28.0 / 37.9
EB-606-B	(M-607-A Jgm x 10 ⁴ (lb-ft-sec ² /kg-m ²))	164.3 / 222.7	159.8 / 216.6	161.7 / 219.2
	Gearhead Size	4	4	5
B-802-B	Tc (lb-ft / N-m)	67.5 / 91.5	113 / 153	225 / 305
BE-802-B	Tp (lb-ft / N-m)	167 / 227	279 / 378	558 / 757
M-803-B	N Max (RPM)	917	550	275
ME-803-B	(B-802-A Jgm x 10 ⁴ (lb-ft-sec ² /kg-m ²))	44.0 / 59.6	39.5 / 53.5	41.4 / 56.1
EB-802-B	(M-803-A Jgm x 10 ⁴ (lb-ft-sec ² /kg-m ²))	267.7 / 363	263.2 / 356.9	265.2 / 359.5
	Gearhead Size	5	5	5
B-804-B	Tc (lb-ft / N-m)	132 / 179	220 / 298	* 391 / 530 *
BE-804-B	Tp (lb-ft / N-m)	338 / 458	563 / 763	1125 / 1525
M-805-B	N Max (RPM)	667	400	200
ME-805-B	(B-804-A Jgm x 10 ⁴ (lb-ft-sec ² /kg-m ²))	95.3 / 129.2	73.2 / 99.2	67.5 / 91.5
EB-804-B	(M-805-A Jgm x 10 ⁴ (lb-ft-sec ² /kg-m ²))	475.1 / 644.2	453.0 / 614.2	447.3 / 606.5
	Gearhead Size	5	5	5
B-804-C	Tc (lb-ft / N-m)	99.3 / 135	165 / 224	331 / 449
BE-804-C	Tp (lb-ft / N-m)	373 / 505	621 / 872	1242 / 1684
M-805-C	N Max (RPM)	1000	600	300
ME-805-C	(B-804-A Jgm x 10 ⁴ (lb-ft-sec ² /kg-m ²))	95.3 / 129.2	73.2 / 99.2	67.5 / 91.5
EB-804-C	(M-805-A Jgm x 10 ⁴ (lb-ft-sec ² /kg-m ²))	475.1 / 644.2	453.0 / 614.2	447.3 / 606.5
	Gearhead Size	5	5	5
B-806-A	Tc (lb-ft / N-m)	188 / 254	313 / 424	* 391 / 530 *
BE-806-A	Tp (lb-ft / N-m)	470 / 637	783 / 1062	* 1546 / 2096 *
M-807-A	N Max (RPM)	517	310	155
ME-807-A	(B-806-A Jgm x 10 ⁴ (lb-ft-sec ² /kg-m ²))	126.3 / 171.2	104.1 / 141.2	98.5 / 134
EB-806-A	(M-807-A Jgm x 10 ⁴ (lb-ft-sec ² /kg-m ²))	688.3 / 933.2	666.2 / 903.2	660.5 / 896
	Gearhead Size	5	5	5
B-806-B	Tc (lb-ft / N-m)	116 / 157	193 / 262	386 / 523
BE-806-B	Tp (lb-ft / N-m)	416 / 564	693 / 940	1386 / 1879
M-807-B	N Max (RPM)	1000	600	300
ME-807-B	(B-806-A Jgm x 10 ⁴ (lb-ft-sec ² /kg-m ²))	126 / 171	104 / 141	98.5 / 134
EB-806-B	(M-807-A Jgm x 10 ⁴ (lb-ft-sec ² /kg-m ²))	688 / 933	666 / 903	660.5 / 896

* Requires amplifier compensation that limits normal motor maximum performance.

Kollmorgen GOLDLINE

PERFORMANCE DATA

Motor Models	Gearmotor Data	Reducer Ratio XX/1		
		20	50	100
	Gearhead Size	4	5	5
B-602-B	Tc (lb-ft / N-m)	177 / 240	442 / 599	* 535 / 725 *
BE-602-B	Tp (lb-ft / N-m)	388 / 526	969 / 1314	* 1362 / 1846 *
M-603-B	N Max (RPM)	150	60	30
ME-603-B	(B-602-A Jgm x 10 ⁴ (lb-ft-sec ² /kg-m ²))	10.1 / 13.7	13.0 / 17.6	12.9 / 17.5
EB-602-B	(M-603-A Jgm x 10 ⁴ (lb-ft-sec ² /kg-m ²))	59.7 / 80.9	62.5 / 84.8	62.5 / 84.7
	Gearhead Size	5	5	5
B-604-B	Tc (lb-ft / N-m)	340 / 461	850 / 1153	* 535 / 725 *
BE-604-B	Tp (lb-ft / N-m)	797 / 1081	* 1880 / 2549 *	* 1362 / 1847 *
M-605-B	N Max (RPM)	158	63	32
ME-605-B	(B-604-A Jgm x 10 ⁴ (lb-ft-sec ² /kg-m ²))	30.6 / 41.4	20.4 / 27.6	20.3 / 27.5
EB-604-B	(M-605-A Jgm x 10 ⁴ (lb-ft-sec ² /kg-m ²))	119.3 / 161.7	109.1 / 147.9	109.0 / 147.8
	Gearhead Size	5	5	5
B-606-B	Tc (lb-ft / N-m)	442 / 599	* 999 / 1354	* 535 / 725 *
BE-606-B	Tp (lb-ft / N-m)	1097 / 1487	* 1880 / 2548	* 1362 / 1847 *
M-607-B	N Max (RPM)	153	61	31
ME-607-B	(B-606-A Jgm x 10 ⁴ (lb-ft-sec ² /kg-m ²))	38.0 / 51.5	27.8 / 37.7	27.7 / 37.6
EB-606-B	(M-607-A Jgm x 10 ⁴ (lb-ft-sec ² /kg-m ²))	171.7 / 232.8	161.5 / 219	161.5 / 218.9
	Gearhead Size	5	5	5
B-802-B	Tc (lb-ft / N-m)	425 / 576	* 999 / 1354 *	* 535 / 725 *
BE-802-B	Tp (lb-ft / N-m)	1054 / 1429	* 1880 / 2548 *	* 1362 / 1847 *
M-803-B	N Max (RPM)	138	55	28
ME-803-B	(B-802-A Jgm x 10 ⁴ (lb-ft-sec ² /kg-m ²))	51.4 / 69.7	41.2 / 55.9	41.2 / 55.8
EB-802-B	(M-803-A Jgm x 10 ⁴ (lb-ft-sec ² /kg-m ²))	275.2 / 373.1	265.0 / 359.3	264.9 / 359.2
	Gearhead Size	5	5	5
B-804-B	Tc (lb-ft / N-m)	* 760 / 1030 *	* 999 / 1354 *	* 535 / 725 *
BE-804-B	Tp (lb-ft / N-m)	* 1880 / 2548 *	* 1880 / 2548 *	* 1362 / 1847 *
M-805-B	N Max (RPM)	100	40	20
ME-805-B	(B-804-A Jgm x 10 ⁴ (lb-ft-sec ² /kg-m ²))	77.5 / 105	67.3 / 91.3	67.3 / 91.2
EB-804-B	(M-805-A Jgm x 10 ⁴ (lb-ft-sec ² /kg-m ²))	457.4 / 620	447.2 / 606.3	447.1 / 606.2
	Gearhead Size	5	5	5
B-804-C	Tc (lb-ft / N-m)	625 / 847	* 999 / 1354 *	* 535 / 725 *
BE-804-C	Tp (lb-ft / N-m)	* 1880 / 2549 *	* 1880 / 2548 *	* 1362 / 1847 *
M-805-C	N Max (RPM)	150	60	30
ME-805-C	(B-804-A Jgm x 10 ⁴ (lb-ft-sec ² /kg-m ²))	77.5 / 105	67.3 / 91.3	67.3 / 91.2
EB-804-C	(M-805-A Jgm x 10 ⁴ (lb-ft-sec ² /kg-m ²))	457.4 / 620	447.2 / 606.3	447.1 / 606.2
	Gearhead Size	5	5	5
B-806-A	Tc (lb-ft / N-m)	* 760 / 1030 *	* 999 / 1354 *	* 535 / 725 *
BE-806-A	Tp (lb-ft / N-m)	* 1880 / 2549 *	* 1880 / 2548 *	* 1362 / 1847 *
M-807-A	N Max (RPM)	78	31	16
ME-807-A	(B-806-A Jgm x 10 ⁴ (lb-ft-sec ² /kg-m ²))	108 / 147	98.3 / 133	98.2 / 133
EB-806-A	(M-807-A Jgm x 10 ⁴ (lb-ft-sec ² /kg-m ²))	671 / 909	660.3 / 895	660.3 / 895
	Gearhead Size	5	5	5
B-806-B	Tc (lb-ft / N-m)	729 / 989	* 999 / 1354 *	* 535 / 725 *
BE-806-B	Tp (lb-ft / N-m)	* 1880 / 2549 *	* 1880 / 2548 *	* 1362 / 1847 *
M-807-B	N Max (RPM)	150	60	30
ME-807-B	(B-806-A Jgm x 10 ⁴ (lb-ft-sec ² /kg-m ²))	108 / 147	98.3 / 133	98.2 / 133
EB-806-B	(M-807-A Jgm x 10 ⁴ (lb-ft-sec ² /kg-m ²))	671 / 909	660.3 / 895	660.3 / 895

* Requires amplifier compensation that limits normal motor maximum performance.

Gearhead Inertia Reflected to GOLDLINE Motor Shaft

Jgh x 10⁴ (Kg-m²)*

Size	Mic#	3/1	5/1	10/1	20/1	50/1	100/1
1	6	0.26	0.11	0.08	0.13	0.08	0.08
2	7.5	0.5	0.32	0.23	0.26	0.21	0.2
3	10	3.4	1.6	1.1	1.3	1	1
4	14	11	4.9	2.9	3.4	2.5	2.5
5	18	45.2	15.2	7.5	21.1	7.3	7.2

*Gearhead inertia does not include motor

Mechanical Specifications

Dimensions	Reducer Model				
	Size 1	Size 2	Size 3	Size 4	Size 5
Backlash (arc min)* Reduction Ratios 3, 5, 10	3	3	6	6	6
Backlash (arc. min.)* Reduction Ratios 20, 50, 100	6	6	10	10	10
Minimum Efficiency (%) Reduction Ratios 3, 5, 10	90	90	90	90	90
Minimum Efficiency (%) Reduction Ratios 20, 50, 100	85	85	85	85	85
Torsional Stiffness [(lb-ft/min) / (N-m/min)]	2.58 / 3.5	5.92 / 8	18.5 / 25	36.9 / 50	129.1 / 175
Maximum Weight (lb/kg) Reduction Ratios 3, 5, 10	4.41 / 2	5.51 / 2.5	13.23 / 6	30.87 / 14	88.20 / 40
Maximum Weight (lb/kg) Reduction Ratios 20, 50, 100	5.51 / 2.5	6.61 / 3	17.64 / 8	39.69 / 18	99.23 / 45
Radial Load (lb/kg) ²	450 / 2000	675 / 3000	1013 / 4500	1688 / 7500	2700 / 12000
Axial Load (lb/kg) ²	450 / 2000	675 / 3000	1013 / 4500	1688 / 7500	2700 / 12000

*Measured at output shaft with 1% rated torque applied.

Ordering Information

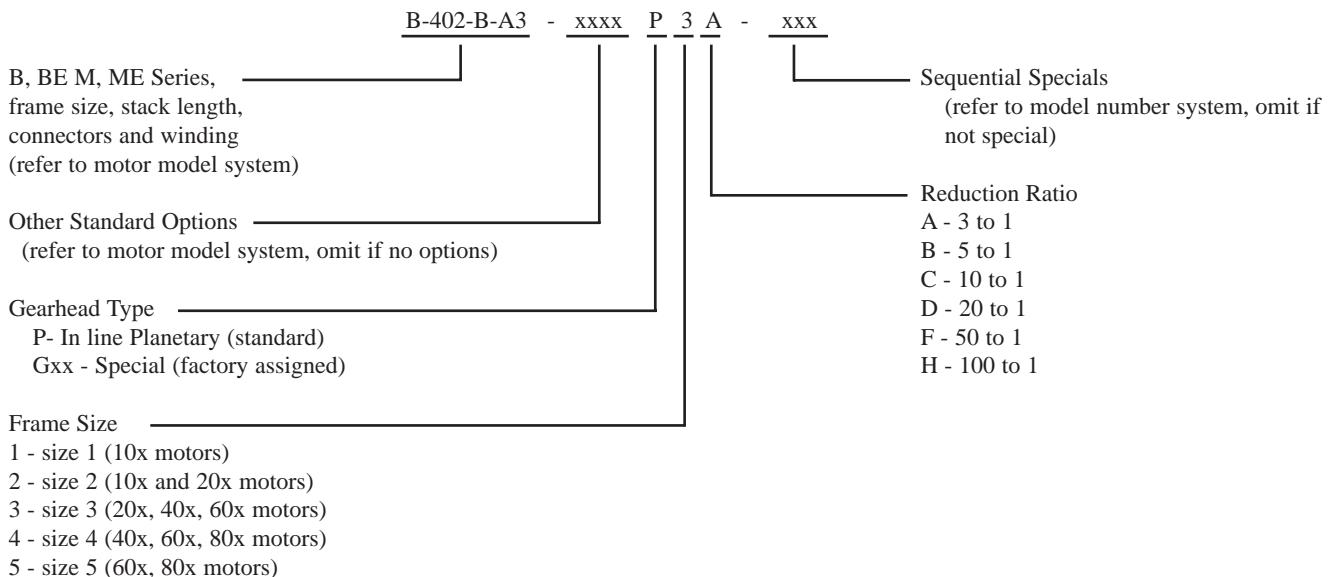

Kollmorgen enjoys a reputation of excellence based on constant endeavors to update products. Information in this brochure is subject to change.

KOLLMORGEN

E-mail: servo@kollmorgen.com
Internet: www.kollmorgen.com
Fax: 1-540-731-0847

Radford, VA (USA) • 1-800-77 SERVO