

SIEMENS

SINUMERIK 840D/840Di
SINUMERIK 810D/FM-NC

Short Guide

10.2000 Edition

Programming

User Documentation

SIEMENS

SINUMERIK 840D/840Di SINUMERIK 810D/FM-NC

Short Guide Programming

Valid for

<i>Control</i>	<i>Software version</i>
SINUMERIK 840D	6
SINUMERIK 840DE (Export version)	6
SINUMERIK 840Di	1
SINUMERIK 840DiE (Export version)	1
SINUMERIK 810D	4
SINUMERIK 810DE (Export version)	4
SINUMERIK FM-NC	3

10.00 Edition

SINUMERIK® documentation

Printing history

Brief details of this edition and previous editions are listed below.

The status of each edition is shown by the code in the "Remarks" column.

Status code in the "Remarks" column:

A New documentation.

B Unrevised reprint with new Order No.

C Revised edition with new status.

If factual changes have been made on the page since the last edition, this is indicated by a new edition coding in the header of that page.

Edition	Order No.	Remark
11.94	6FC5298-0AB30-0BP0	A
04.95	6FC5298-2AB30-0BP0	C
03.96	6FC5298-3AB30-0BP0	C
08.97	6FC5298-4AB30-0BP0	C
12.98	6FC5298-5AB30-0BP0	C
10.00	6FC5298-6AB30-0BP0	C

This manual is included in the documentation available on CD-ROM (**DOCONCD**)

Edition	Order No.	Remark
10.00	6FC5298-6CA00-0BG0	C

Further information is available on the Internet under:
<http://www.ad.siemens.de/sinumerik>

This publication was produced with WinWord V 7.0 and Designer V 4.0

Other functions not described in this documentation might be executable in the control. This does not, however, represent an obligation to supply such functions with a new control or when servicing.

Subject to technical change without prior notice.

The reproduction, transmission or use of this document or its contents is not permitted without express written authority. Offenders will be liable for damages. All rights, including rights created by patent grant or registration of a utility model or design are reserved.

© Siemens AG 1994 - 2000. All Rights Reserved.

Introduction

How to use this booklet

This booklet is a programming guide describing all the main programming steps.

The aim is to provide the operator with some quick help and a memory aid especially for commands that are used infrequently or to offer a quick reference guide on various parameters.

The guide therefore has little text and is easily comprehensible.

First familiarize yourself with the symbols below so that you understand them better whenever they occur on the following pages.

The symbols



Gives you a tip or background information.



Points out hazards, sources of error or general problems.

Structure of the descriptions



The system used in these descriptions is based on the following scheme:

Programming of the function

Meaning of the parameters

Explanatory illustration with example workpiece

List of sections

1. What is at the Beginning of the Program	1-9
Absolute and incremental dimensions, G90, G91	1-10
Zero offset, G54 to G57	1-12
Selection of working plane G17 to G19	1-14
2. Programming Motion Commands	2-17
Rapid traverse, G0	2-18
Linear interpolation, G1	2-20
Circular interpolation, G2/G3	2-22
Radius programming, G2/G3	2-24
Circular interpolation through intermediate point, CIP	2-25
Thread cutting, G33	2-27
Rigid tapping, G331/G332	2-28
Tapping with floating tapholder, G63	2-29
Polar coordinates G110, G111, G112	2-30
3. Tool Offsets and Compensations	3-31
Tool call	3-32
Cutter radius path compensation, G41/G42	3-33
Tool nose radius compensation, G41/G42	3-34
Activating/deactivating the collision detection	3-35
Approach and exit the contour, NORM/KONT	3-36
Programmable contour travel mode, G450/G451	3-37
4. Programming Aids Assist the Programmer	4-39
Overview of frame concept	4-40
Translating/rotating the coordinate system, TRANS/ROT	4-42
Mirroring on the coordinate axes, MIRROR	4-44
Increasing/reducing size of contour, SCALE	4-45
5. Programming Preparatory Functions	5-47
Feedrate programming, G93 to G97	5-48
Exact stop, G9/G60	5-49
Feedrate in continuous path mode, G64, G641	5-50
Programming the spindle motion	5-51
6. Subroutine Technique and Cycles	6-53
Subroutine technique	6-55
The use of cycles	6-57
Explanation of parameters	6-58
Drilling, centering, CYCLE81	6-62
Drilling, counterboring, CYCLE82	6-63
Deep hole drilling, CYCLE83	6-64
Rigid tapping, CYCLE84	6-65
Tapping with floating tapholder, CYCLE840	6-66
Bore 1, CYCLE85	6-67
Bore 2, CYCLE86	6-68
Bore 3, CYCLE87	6-69

Bore 4, CYCLE88.....	6-70
Bore 5, CYCLE89.....	6-71
Row of holes, HOLES1	6-72
Hole circle, HOLES2	6-73
Elongated holes on a circle, LONGHOLE	6-74
Slots on a circle, SLOT1	6-75
Circumferential slot, SLOT2	6-76
Rectangular pocket milling, POCKET1	6-77
Circular pocket milling, POCKET2	6-78
Thread cutting, CYCLE90	6-79
Recessing cycle, CYCLE93	6-80
Undercut cycle, CYCLE94	6-81
Stock removal cycle, CYCLE95	6-82
Thread undercut, CYCLE96	6-83
Thread cutting, CYCLE97	6-84
Chaining of threads, CYCLE98	6-85
7. Predefined Switching and Auxiliary Functions	7-87
List of M commands	7-88
Forms	7-89
8. Program Key	8-91
List of G functions	8-92

1. What is at the Beginning of the Program

Absolute and incremental dimensions, G90, G91	1-10
Zero offset, G54 to G57	1-12
Selection of working plane G17 to G19	1-14

Absolute and incremental dimensions, G90, G91

Programming

```
N5 G0 G90 X25 Y15 Z2 LF
N20 G1 G91 X80 F300 LF
```

- G90 Absolute dimension input, all data refers to the actual workpiece zero.
- G91 Incremental dimension input, each dimension refers to the contour point last input.

You can change over from block to block as often as you want between absolute and incremental data input.

Within a block, you can also change the type of input for individual axes by specifying AC for absolute coordinates or IC for incremental coordinates.
 Example: X = AC (400)



Milling:

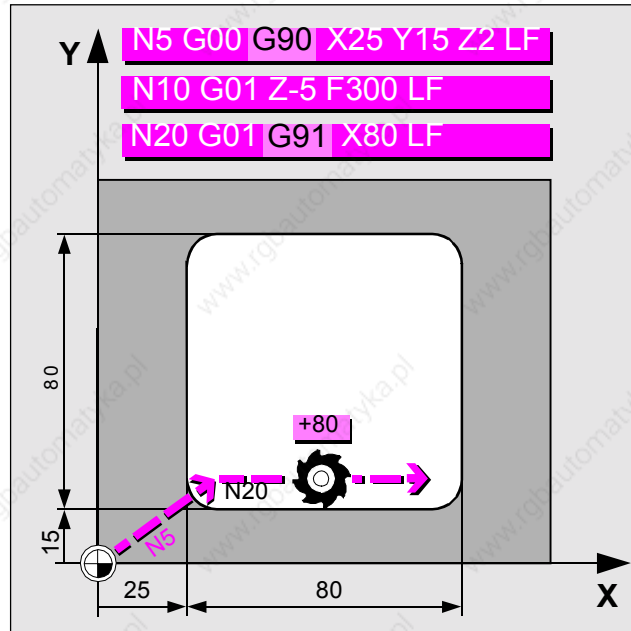

Change between absolute and incremental dimension programming

Absolute and incremental dimensions, G90, G91 (cont.)

Programming

```

N5 G0 G90 X25 Z1
N10 G1 Z-7.5 F0.2
N20 G1 X40 Z-15
N30 G1 G91 Z-10
N40 G1 G90 X60 Z-35

```

G90 Absolute dimension input, all data refers to the actual workpiece zero.

G91 Incremental dimension input, each dimension refers to the contour point last input.

Turning:

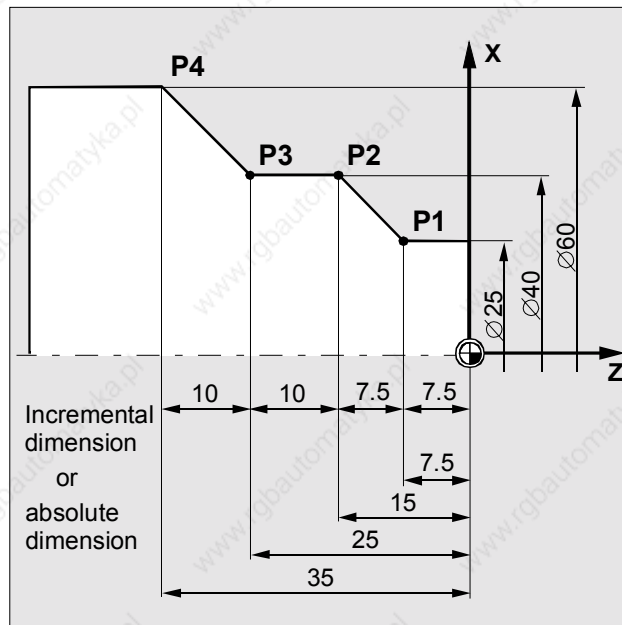

Dimensions: incremental or absolute dimensions

Zero offset, G54 to G57

Programming

```
N30...LF
N40 G54 LF
N50 G0 X30 Y75LF
```

Other zero offsets: G55...G57, G505...G599

Parameters

X,Y,Z Coordinates of the zero offsets (definition of workpiece coordinate system). These must have been input via operator panel or universal interface into the control before programming.



With command G53, zero offsets can be suppressed block by block; deactivate with G50.

Milling:

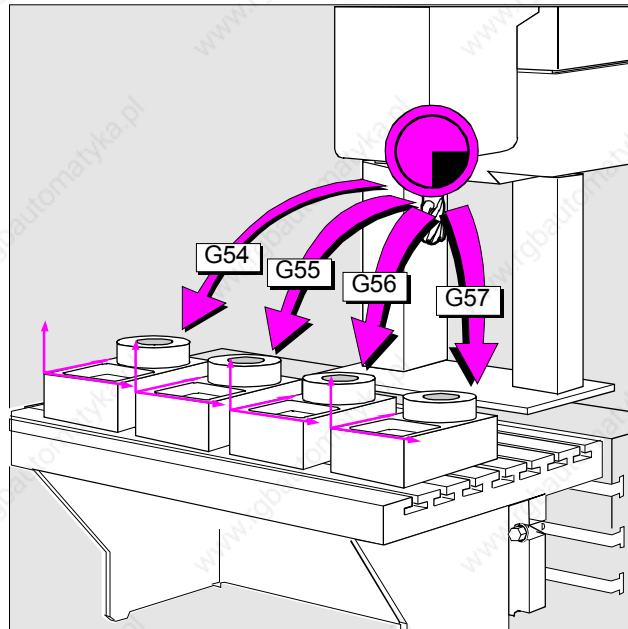

Zero offsets make multiple machining operations possible

Zero offset, G54 to G57 (cont.)

Programming

```
N10 G54
N20 G0 Z0.2
```

Parameter

Z Coordinates of the zero offsets (definition of workpiece coordinate system). These must have been input via operator panel or universal interface into the control before programming.

In turning machines, a zero offset is generally advisable in the Z direction only.

Turning:

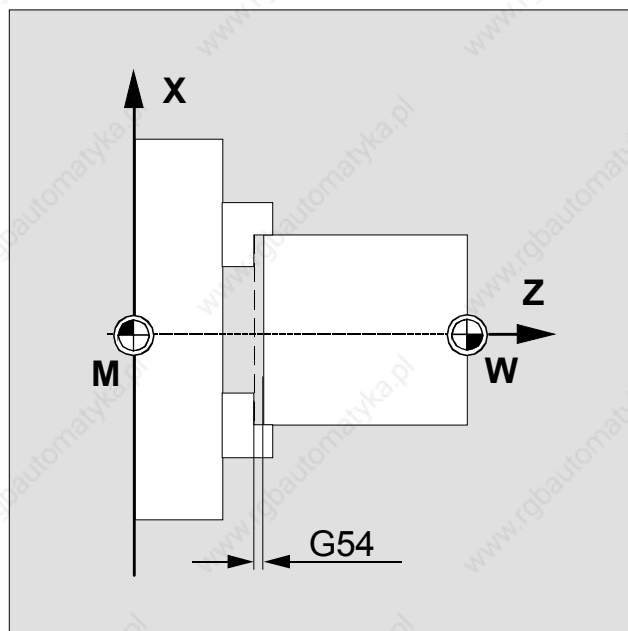

Zero offsets in the Z direction

Selection of working plane G17 to G19

Programming

```
N10 G0 X50 Z50 G17 D1 F1000 LF
```

Command	Working plane	Infeed axis
G17	X/Y	Z
G18	Z/X	Y
G19	Y/Z	X



Programming of the working plane is needed for computation of the tool offset data.
It is not possible to change the working plane when G41/G42 is active.

Milling:

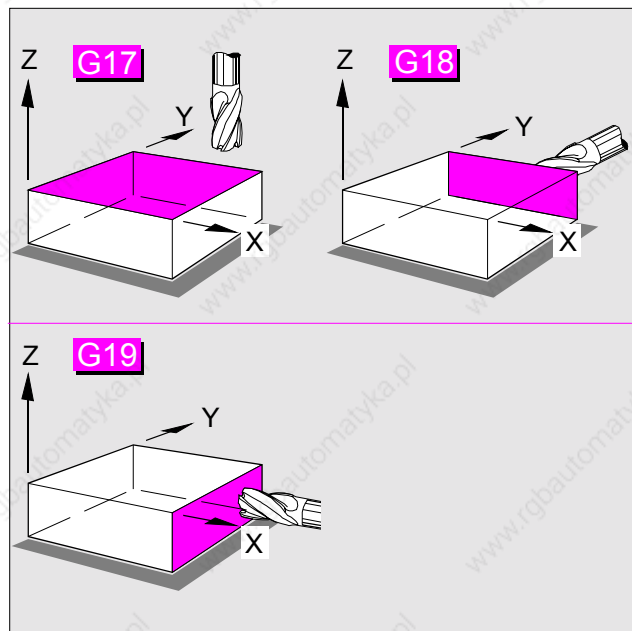

Selection of working planes for horizontal and vertical milling operations

Selection of working plane, G17 to G19 (cont.)

Programming

```
N10 G0 X10 Z20 G18 D1 F200
```



In the basic setting, G17 is preset for milling (X/Y plane) and G18 for turning (Z/X plane).

Turning:

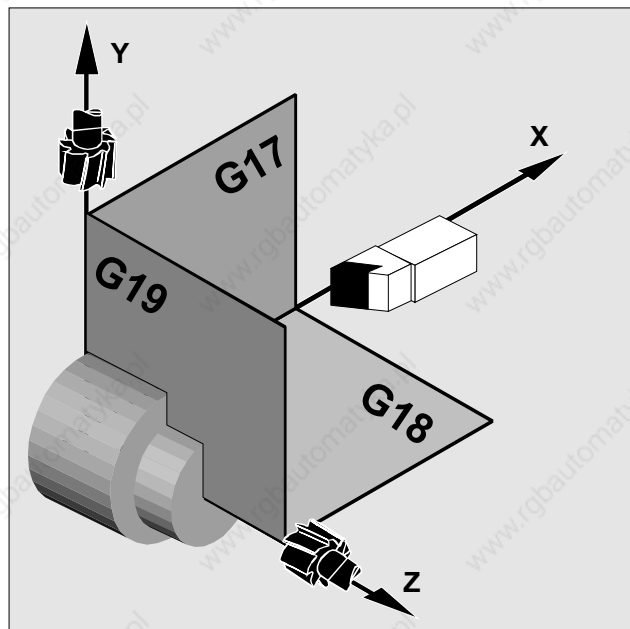

Selection of working planes for horizontal and vertical turning operations

2. Programming Motion Commands

Rapid traverse, G0	2-18
Linear interpolation, G1	2-20
Circular interpolation, G2/G3	2-22
Radius programming, G2/G3	2-24
Circular interpolation through intermediate point, CIP	2-25
Thread cutting, G33	2-27
Rigid tapping, G331/G332	2-28
Tapping with floating tapholder, G63	2-29
Polar coordinates G110, G111, G112	2-30

Rapid traverse, G0

Programming

```
N10 G0 X0 Y0 Z3 LF
```

Parameters

X, Y, Z Coordinates of the target point

Milling:

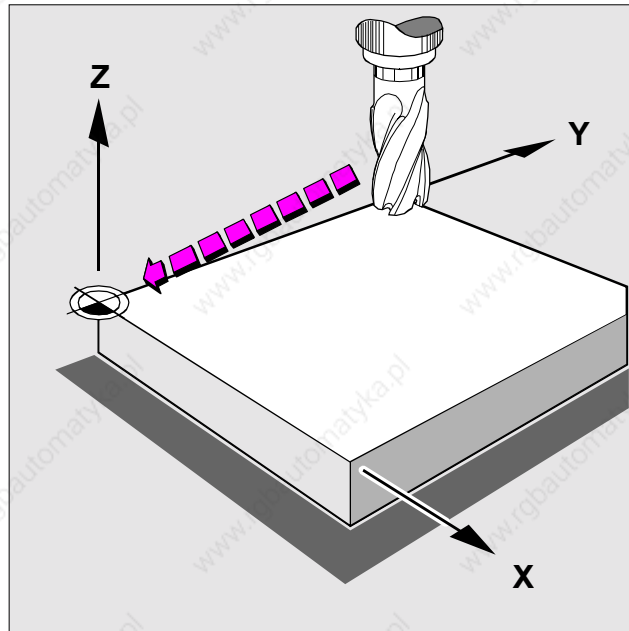

Fast tool positioning in rapid traverse for milling

Rapid traverse, G0 (cont.)

Programming

N20 G0 **X25 Z1**

Parameters

X, Z Coordinates of the target point

Turning:

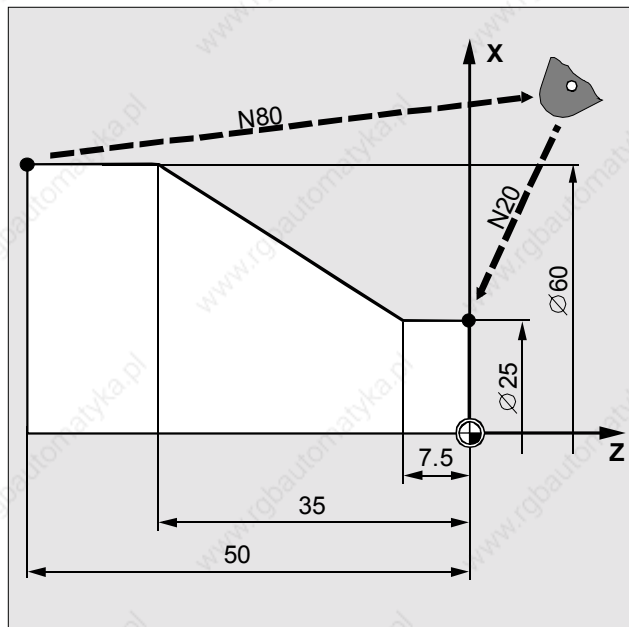

Fast tool positioning in rapid traverse for turning

Linear interpolation, G1

Programming

```
N10 G0 G90 X10 Y10 Z1 S800 M3 LF  
N20 G1 Z-12 F500 LF  
N30 X30 Y35 Z-3 F700 LF
```

Parameters

X, Y, Z Coordinates of the target point
F Feedrate

Milling:

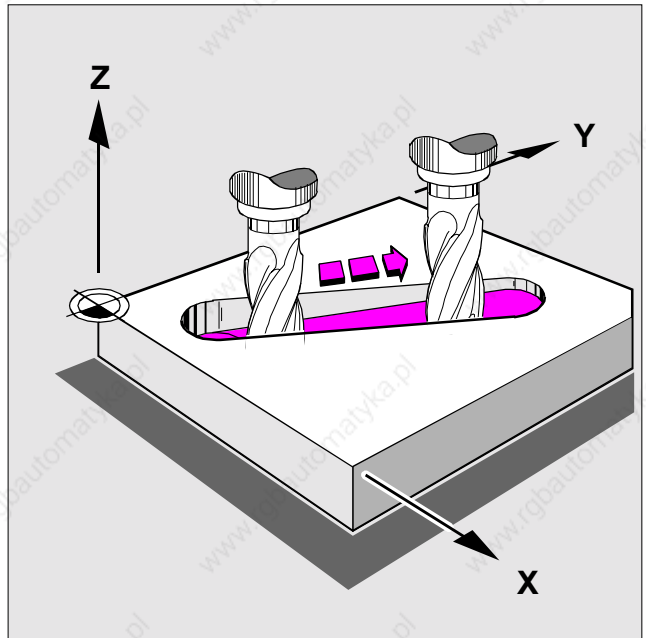

Making an inclined slot

Linear interpolation, G1 (cont.)

Programming

```

N10 G17 S400 M3
N20 G0 X40 Y-6 Z2
N30 G1 Z-3 F40
N40 X12 Y-20
    
```

Parameters

X, Y, Z Coordinates of the target point
 F Feedrate

Turning/milling:

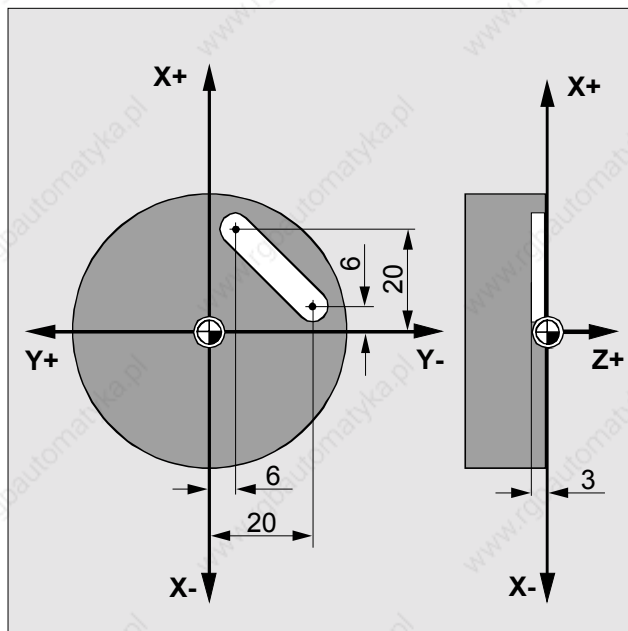

Making a slot

Circular interpolation, G2/G3

Programming

```
N5 G0 G90 X35 Y60 LF
N10 G3 X50 Y45 I0 J-15 F500 LF
```

Parameters

X, Y, Z Coordinates of the circle end point
 I, J, K Interpolation parameters (directions: I in X, J in Y, K in Z) for determining the circle center point
 AR Opening angle



With G2 the tool travels clockwise, with G3 counterclockwise. Viewing direction along the third coordinate axis.
 When programming with the opening angle the circle center point or circle end point must also be specified.

Milling:

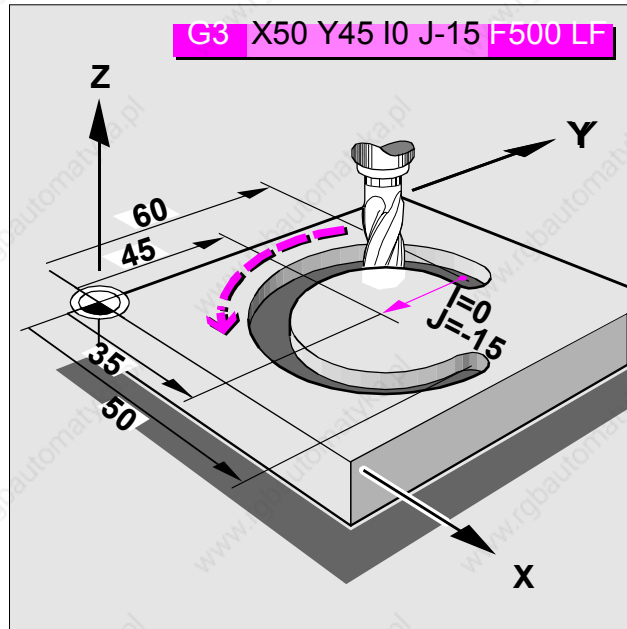

Making a circular slot

Circular interpolation, G2/G3 (cont.)

Programming

```

N10 G0 X12 Z0
N20 G1 X40 Z-25 F0.2
N30 G3 X70 Z-75 I-3.335 K-29.25

```

Parameters

X, Y, Z Coordinates of the circle end point
 I, K Interpolation parameters (directions: I in X, K in Z) for determining the circle center point

Turning:

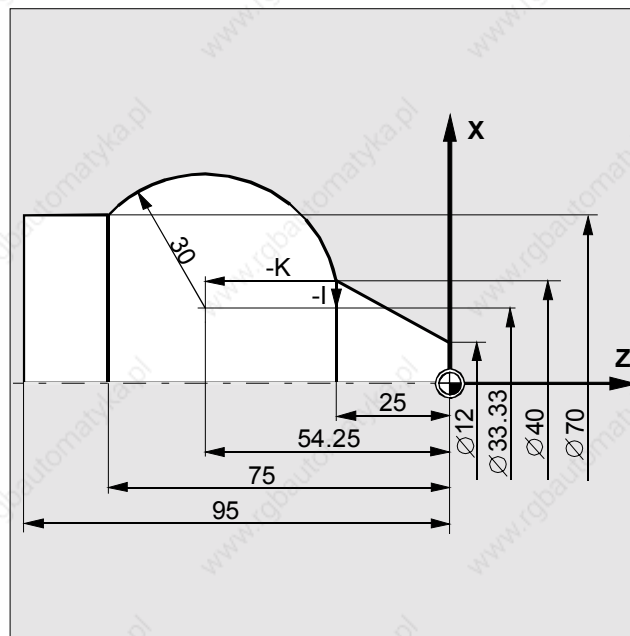

Making a ball end bolt

Radius programming, G2/G3

Programming

```
N20 G90 G0 X68 Z102
N30 G90 G3 X20 Z150 CR=48 F300 LF
```

Parameters

- CR Circle radius
- CR+ Traversed angle $\leq 180^\circ$
- CR- Traversed angle $> 180^\circ$
- X... Z... Definition of end point



Radius programming is not allowed if the traversed angle is 360° .

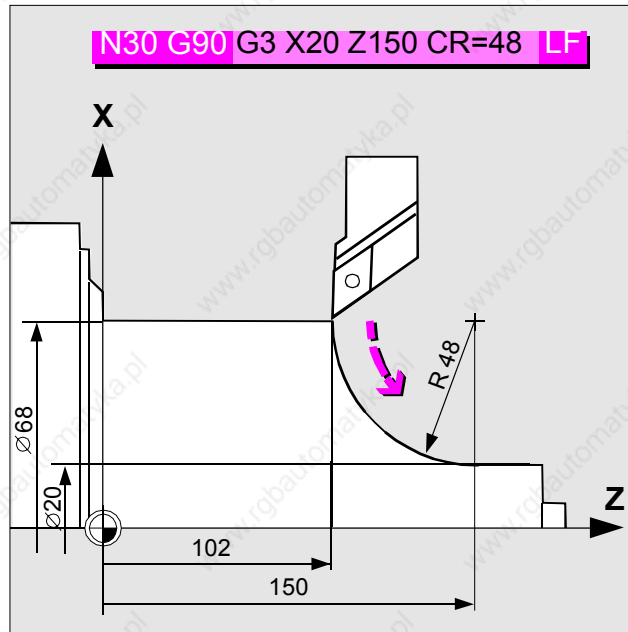

Radius programming from drawing

Circular interpolation through intermediate point, CIP

Programming

```
N10 CIP X87 Y20 I1=60 J1=35 LF
```

Parameters

X, Y, Z Coordinates of the circle end point
I1, J1, K1 Interpolation parameters for determining the intermediate point



If the circle parameter point is not given in the production drawing, you can program circular interpolations with CIP without additional calculations.
You can also use this function to program circles in space.

Milling:

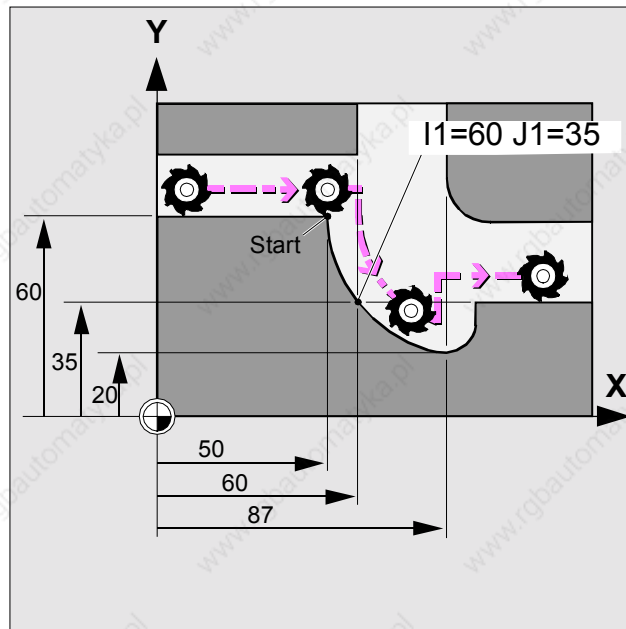

Circular interpolation through intermediate point

Circular interpol. through interm. point, CIP (cont.)

Programming

```
N90 G1 X40 Z-25
N100 CIP X70 Z-75 I1=93.33 K1=-54.25
```

Parameters

X, Z Coordinates of the circle end point
 I1, K1 Interpolation parameters for determining the intermediate point

Turning:

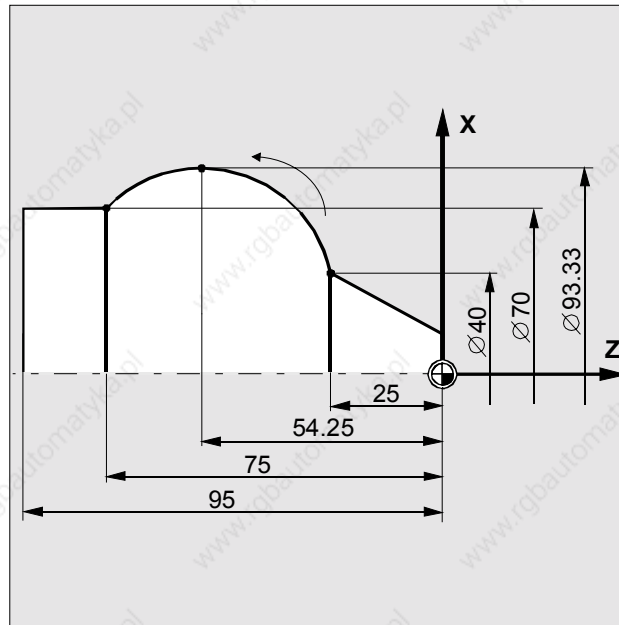

Circular interpolation through intermediate point

Thread cutting, G33

Programming

```
N20 G33 Z22 K2 LF
```

Parameters

- Z, X Thread end point
- K Thread lead for cylindrical thread
- I Thread lead for face thread
- I Thread lead for taper thread (angle of taper > 45°)
- K Thread lead for taper thread (angle of taper < 45°)
- SF Start point offset in degrees



Right-hand or left-hand threads are programmed by specifying the direction of spindle rotation M3/M4. Spindle rotation and speed must be programmed in the block before G33.



For programming taper threads, enter the X and Z coordinates with G33. Multiple threads can be programmed with offset start points (SF=...).

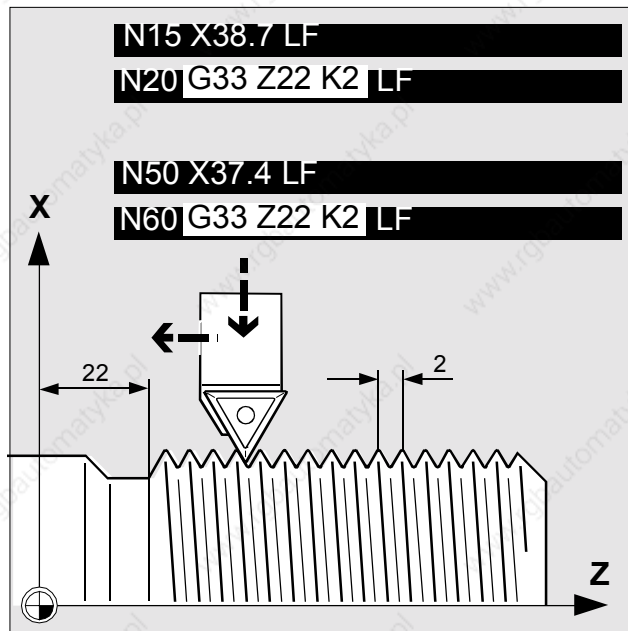

Making a longitudinal thread

Rigid tapping, G331/G332

Programming

N40	SPOS=0	LF
N50	G331 Z-50 K2 S500	LF
N60	G332 Z5 K2	LF

SPOS=0 Change spindle to position control and put into position

G331 Tapping

G332 Tapping with retraction. The spindle changes direction of rotation automatically

Parameters

X, Y, Z Thread end point

I, J, K Thread lead. Positive lead (e.g. K4) right-hand thread, negative lead (e.g. K-4) left-hand thread.

For this function, the spindle must be equipped with a pulse generator.

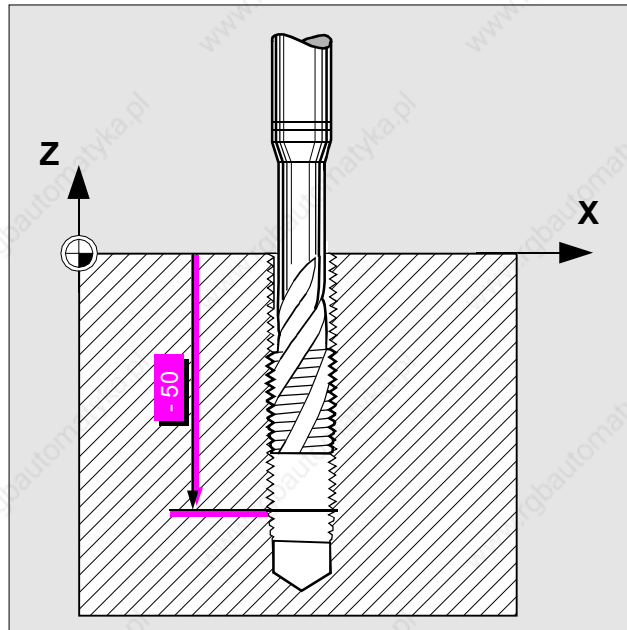

Tapping

Tapping with floating tapholder, G63

Programming

```
N10 G63 Z-50 M3 S...F...LF
N20 G63 Z4 M4 F...LF
```

G63 For the retraction movement, you program another block with G63 and the relevant direction of spindle rotation.

Parameters

S Spindle speed
 F Feedrate
 M3 Direction of rotation right
 M4 Direction of rotation left
 Calculation of feedrate:
 $F = \text{Spindle speed} \times \text{Thread lead}$



For this function, you need a tap in the floating tapholder. A pulse generator is not needed for the spindle.

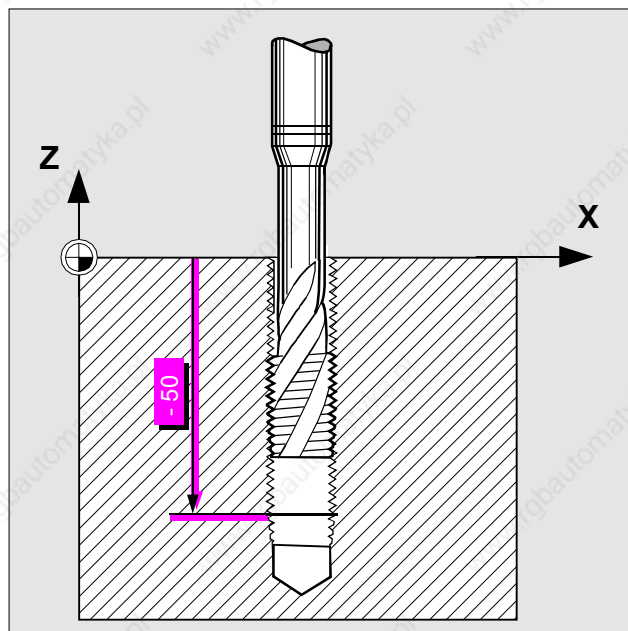

Tapping with floating tapholder

Polar coordinates G110, G111, G112

Programming

```
N30 G111 X40 Y35 Z40 LF
N40 G3 RP... AP... LF
```

- G110 Definition of pole, referred to tool position last programmed
- G111 Definition of pole, absolute in the workpiece coordinate system
- G112 Definition of pole, referred to pole last valid

Parameters

- X, Y, Z Coordinates of the pole
- RP Radius, distance between pole and target point
- AP Angle between path between pole and target point and the angle reference axis (pole axis first named)



The pole (center point) can be defined in rectangular or polar coordinates.
 When programming the circle, the pole is in the circle center point and RP corresponds to the circle radius.

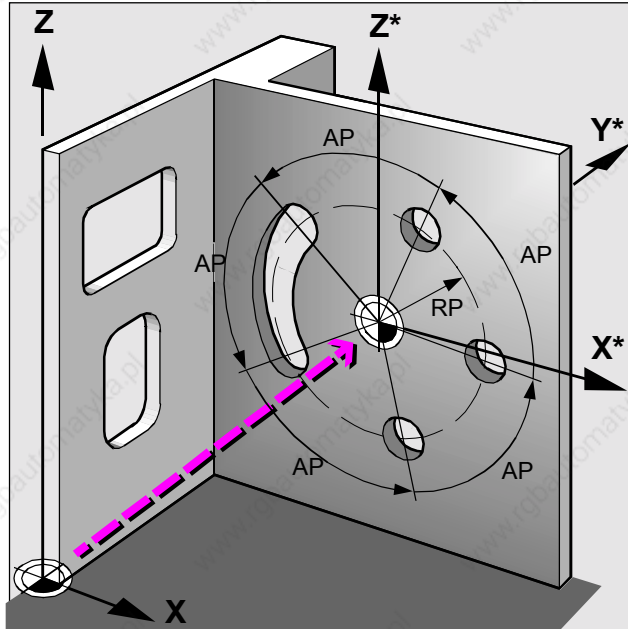

Description of travel paths using polar coordinates

3. Tool Offsets and Compensations

Tool call	3-32
Cutter radius path compensation, G41/G42	3-33
Tool nose radius compensation, G41/G42	3-34
Activating/deactivating the collision detection	3-35
Approach and exit the contour, NORM/KONT	3-36
Programmable contour travel mode, G450/G451	3-37

Tool call

Programming

```
N10 G18 T17 D8 LF
```

T... Call tool number
D... Call tool offset, activate tool length compensation



To make sure that the tool offset values are calculated correctly in the axes, the machining level must be selected before calling the tool.



Tool offset values can be exchanged in the course of the NC run. The machining plane does not have to be reprogrammed.



If no D number is to be input when the tool is called, a D number can be specified via machine data.

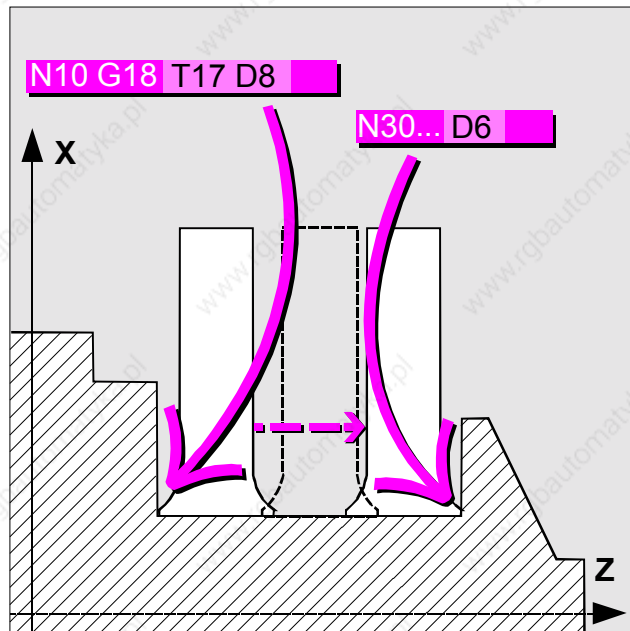

Offset values for left-hand and right-hand tool nose for recessing tool

Cutter radius path compensation, G41/G42

Programming

```
N10 G1 G17 G41 D8 X... Y... Z... F500 LF
```

- G41 Call for cutter path compensation, tool in traversing direction left of contour
- G42 Call for cutter path compensation, tool in traversing direction right of contour
- G40 Deselection of cutter path compensation

The tool length compensation acts automatically after tool offset D has been called.

In the NC block with G40/G41/G42 at least one axis of the selected working plane (G17 to G19) must be programmed.

Selection and deselection of the CRC must be made in a program block with G0 or G1.
The offset acts only in the programmed working plane (G17 to G19).

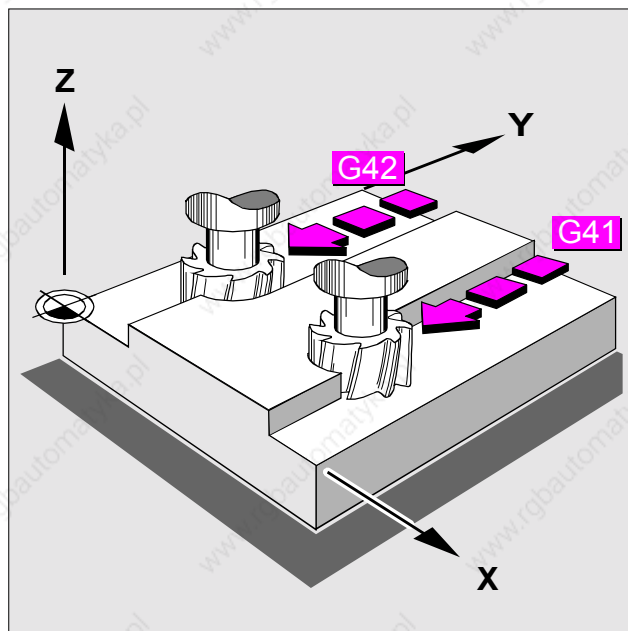

The control computes the tool path

Tool nose radius compensation, G41/G42

Programming

```
N5 G90 G0 G18 G41 D... X... Y... Z... LF
```

G41	Call for radius compensation, tool motion in traversing direction left of workpiece
G42	Call for radius compensation, tool motion in traversing direction right of workpiece
G40	Deselection of radius compensation



In the NC block with G40/G41/G42 at least one axis of the selected working plane (G17 to G19) must be programmed.

Selection and deselection of the compensation must be made in a program block with G0 or G1. The compensation acts only in the programmed working plane (G17 to G19).

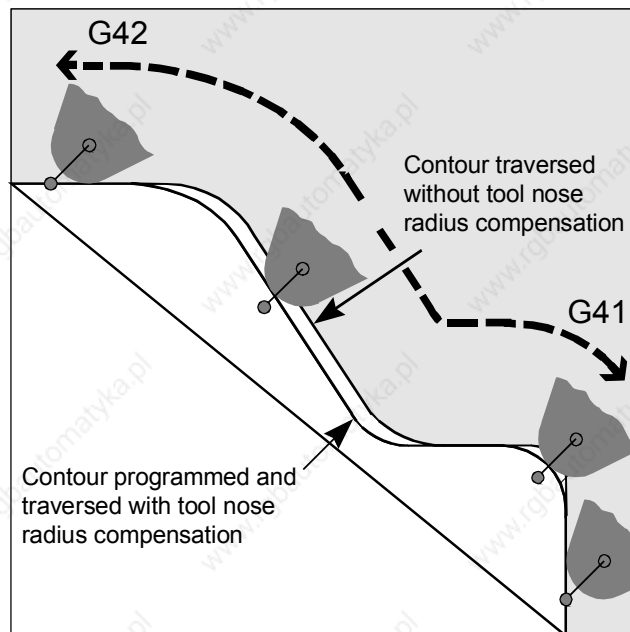

Tool nose radius compensation for machining slopes and circular arcs

Activating/deactivating the collision detection

Programming

```
N10 G41 X...Y...Z... CDON LF
```

CDON Collision detection on
CDOF Collision detection off



The control detects and corrects critical machining situations.

Example: For machining the inside corner, a tool radius has been selected that is too high.

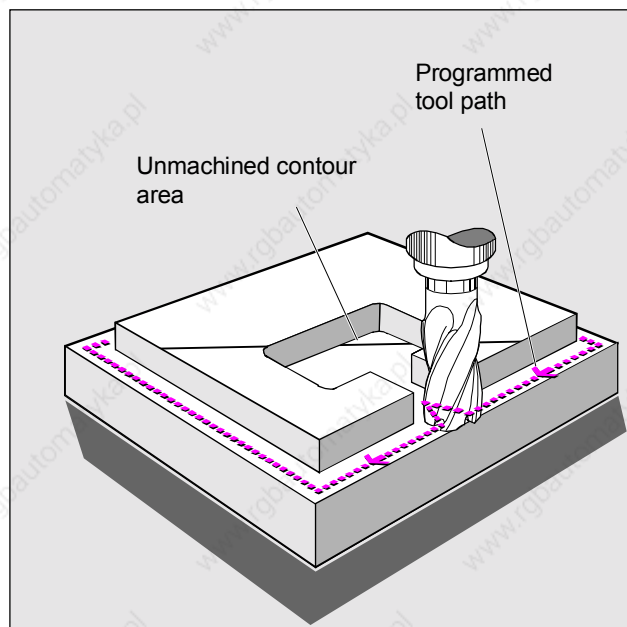

The control takes action in good time

Approach and exit the contour, NORM/KONT

Programming

KONT G41 G450 X... Y... Z... LF

- NORM** The tool travels directly along a straight line and is perpendicular to the contour point.
- KONT** The tool travels around the contour point in accordance with the programmed behavior at corners G450/G451.



For KONT: If start point and contour point are on one side of a workpiece, the contour point is approached as with NORM directly along a straight line.

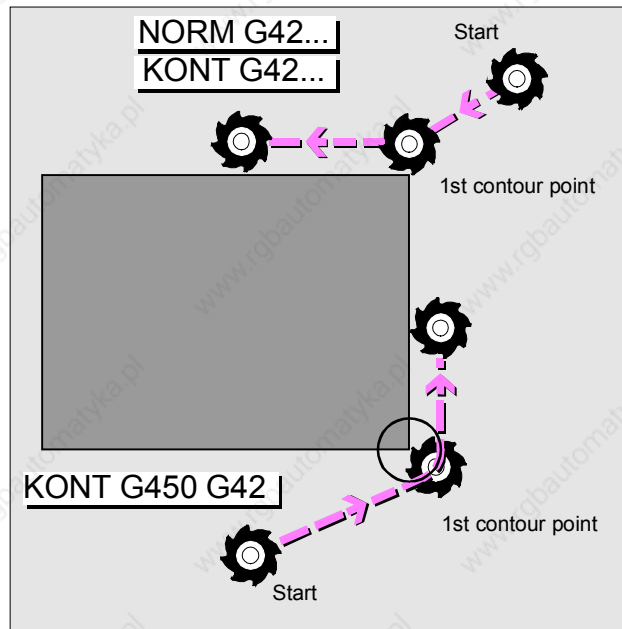

Programmable behavior for approach and exit

Programmable contour travel mode, G450/G451

Programming

N10 G41 G450 X... Y... Z... LF

G450 Transition circle, the tool travels around workpiece corners along a circular path with tool radius.

G451 Intersection point, the tool cuts free in the workpiece corner.

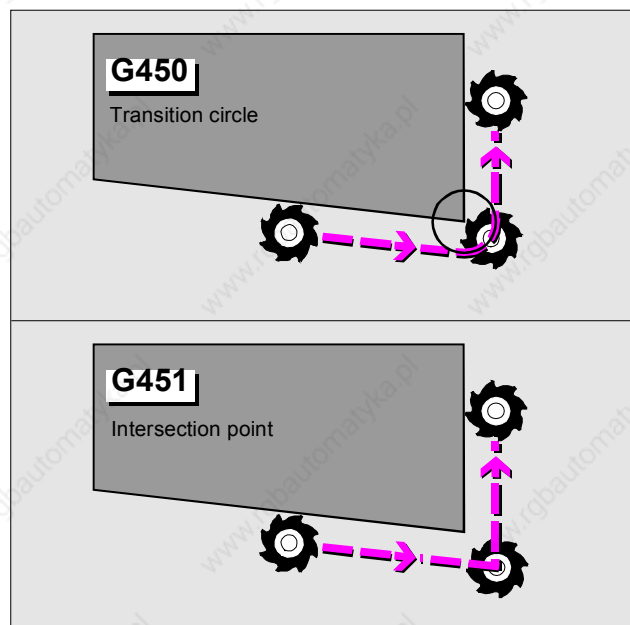

Tool travel behavior at workpiece corners

4. Programming Aids Assist the Programmer

Overview of frame concept	4-40
Translating/rotating the coordinate system, TRANS/ROT	4-42
Mirroring on the coordinate axes, MIRROR	4-44
Increasing/reducing size of contour, SCALE	4-45

Overview of frame concept

Programming

For the three-dimensional description of the workpiece coordinate system, the following functions are available.

TRANS/ATRANS	Translation of the zero point
ROT/AROT	Rotation
SCALE/ASCALE	Change of scale
MIRROR/AMIRROR	Mirroring

The actual coordinate system can be anywhere in space. This also allows skew contours to be produced.



Milling:

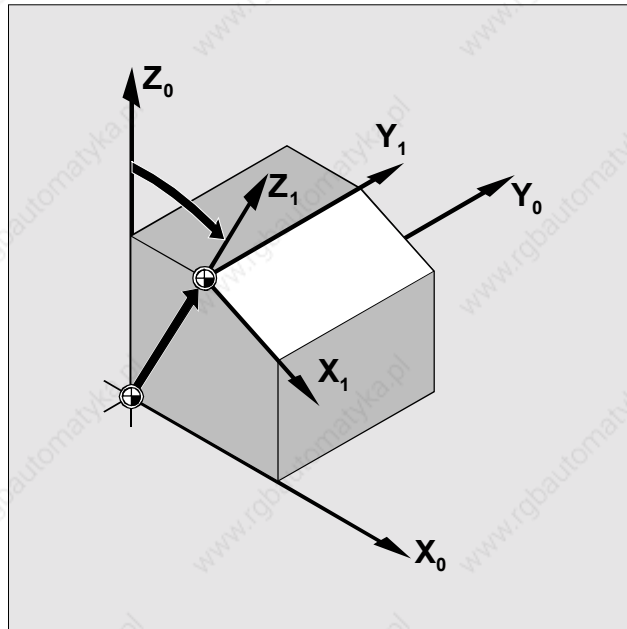

Programmable frames allow inclined contours to be machined

Overview of frame concept (cont.)

Turning:

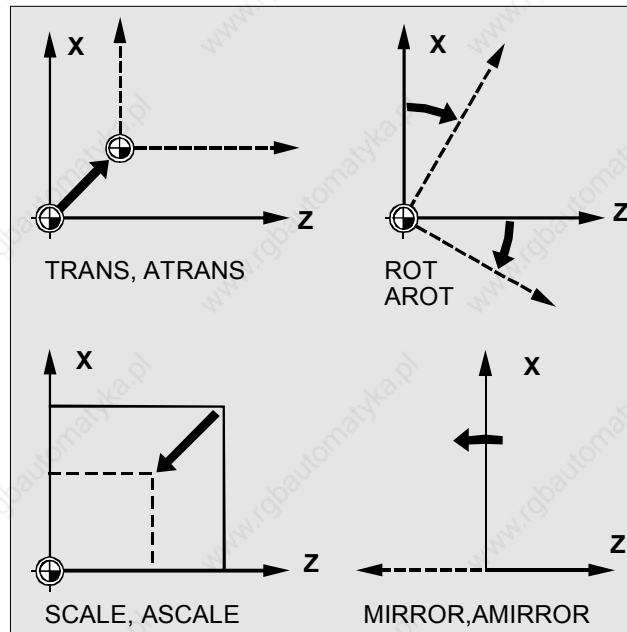

Programmable frames allow inclined contours to be machined

Translating/rotating the coordinate system, TRANS/ROT

Programming

```
N30...G54 LF
N40 G90 TRANS X40 Y40 Z30 LF
N50 G90 AROT Z 30 LF
```

To switch off ZO: TRANS (without specifying axis)
 To switch off rotation: ROT (without specifying angle)

In all cases, the complete frame is deleted here!

- TRANS Absolute translation
- ATRANS Additive translation
- X, Y, Z Coordinates of zero offset in axial direction
- ROT Absolute rotation
- AROT Additive rotation
- X, Y, Z Coordinate axis about which rotation occurs in angular degrees (positives sign = counterclockwise rotation)



Parameters

Parameters

Milling:

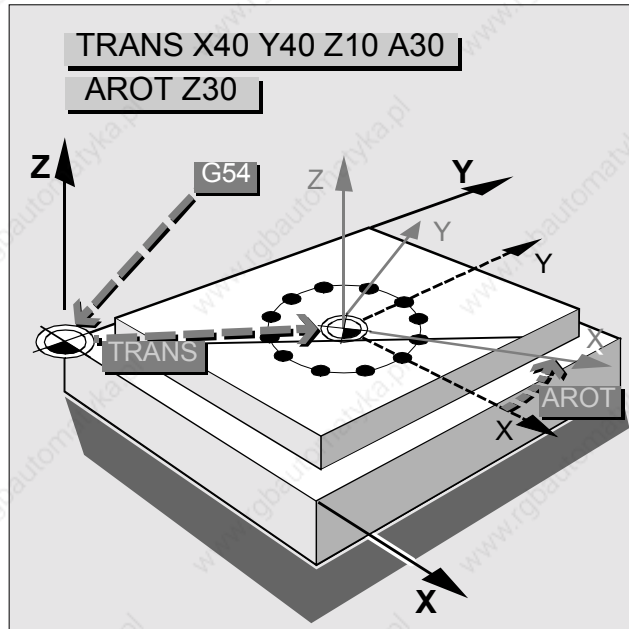

Changing the zero point for producing a drilling pattern

Translating/rotating the coordinate system, TRANS/ROT

Programming

```
N30...G54
N40 TRANS Z150
```

Parameter

TRANS Absolute translation
 ATRANS Additive translation
 Z Coordinates of zero offset in axial direction



On turning machines, a zero offset is usually sensible in the Z direction only.

Turning:

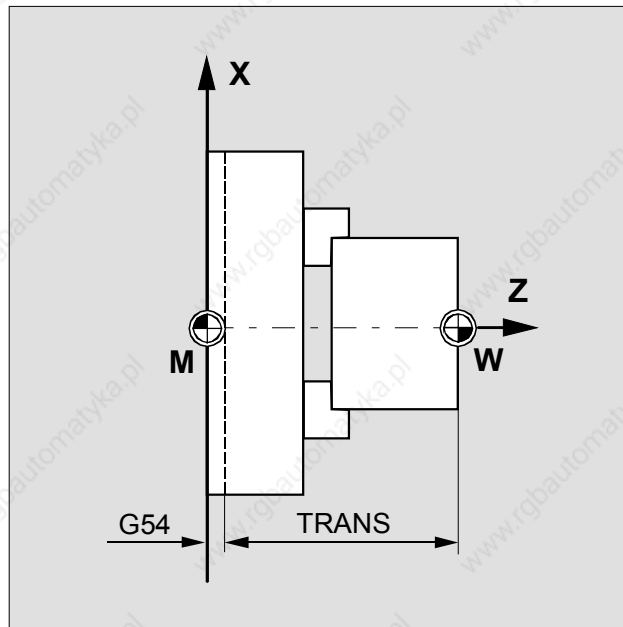

Changing the zero point in the Z direction

Mirroring on the coordinate axes, MIRROR

Programming

N10 MIRROR X0 **LF**
Switch off MIRROR (without defining axis)



In all cases, the complete frame is deleted here!

Parameters

MIRROR Absolute mirroring
AMIRROR Additive mirroring
X, Y, Z Address with value 0 of the axis at which mirroring takes place.



When mirroring on a coordinate axis, the control changes

- the signs of the mirrored coordinates,
- the direction of rotation of circular interpolations and
- the machining directions (G41/G42).

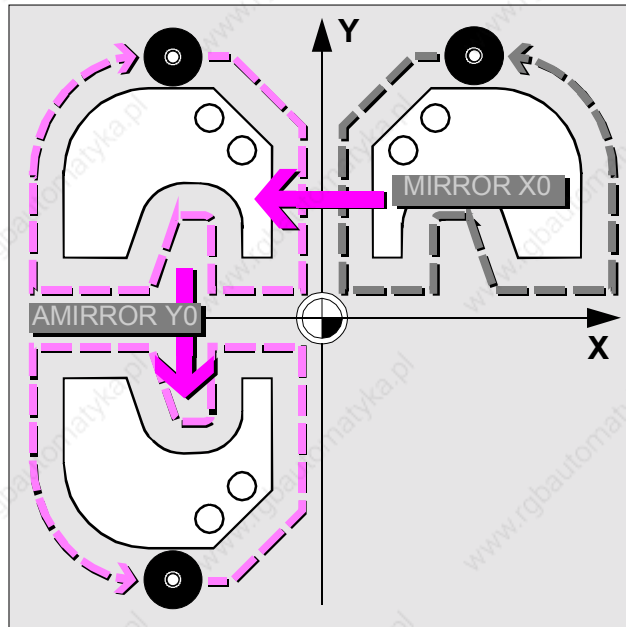

No additional programming for symmetrical contours

Increasing/reducing size of contour, SCALE

Programming

N10 SCALE X2 Y2 **LF**
Switch off SCALE (without defining axis)



In all cases, the complete frame is deleted here!

Parameters

SCALE New scale factor
 ASCALE Additive scale factor
 X, Y, Z Axes with scale factor in the direction of which the contour is to be increased or reduced in size.



If transformation follows with ATRANS, the offset values are also scaled.



Any contours that you wish to increase or reduce in size are best defined in a subroutine.

You can define an individual scale factor for each axis.

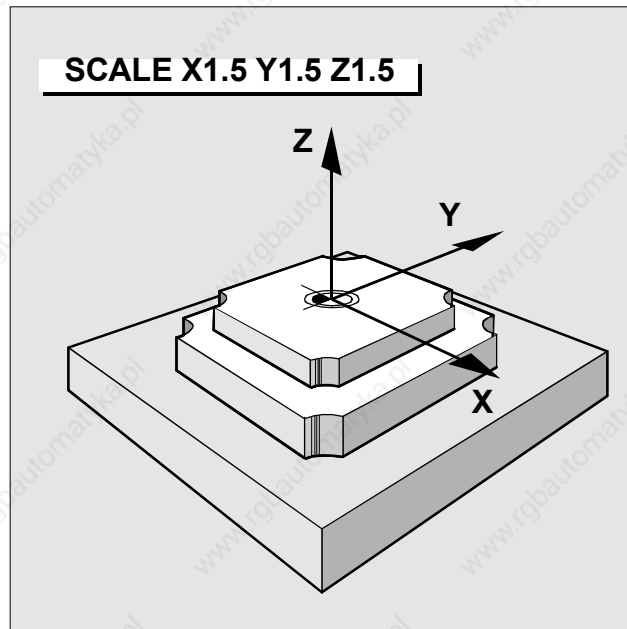

No additional programming for similar contours

5. Programming Preparatory Functions

Feedrate programming, G93 to G97	5-48
Exact stop, G9/G60	5-49
Feedrate in continuous path mode, G64, G641	5-50
Programming the spindle motion	5-51

Feedrate programming, G93 to G97

Programming

```
N5 G90 G00 X... Y... Z... LF
N10 G94 F500 G01...M3 LF
```

G93 F Feedrate in 1/min (inverse time feedrate)
 G94 F Constant speed and feedrate in mm/min
 G95 F Constant speed and feedrate in mm/revolution
 G96 S Constant cutting velocity in m/min
 F Feedrate in mm/revolution
 G97 Switch off G96, store the last speed setpoint of G96 as constant speed.



The maximum feedrates and speeds are defined by the machine manufacturer.

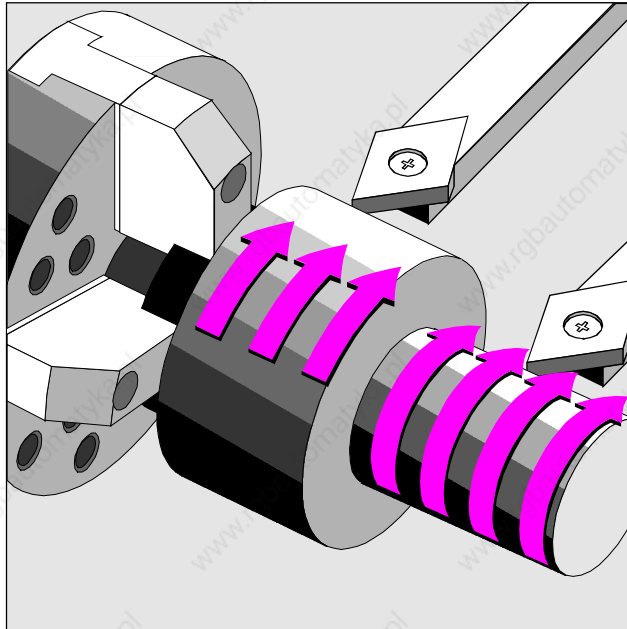

Automatic speed control for constant cutting velocity

Exact stop, G9/G60

Programming

- G601 Exact positioning fine
- G602 Exact positioning coarse
- G603 Exact positioning at end of interpolation
- G9 Exact positioning, active in the block
- G60 Exact positioning, modal, active until deselected by G64, G641.



The exact positioning functions are used in order to produce sharp outside corners or to finish inside corners to the required dimension.



The exact positioning limits are defined in the machine data.

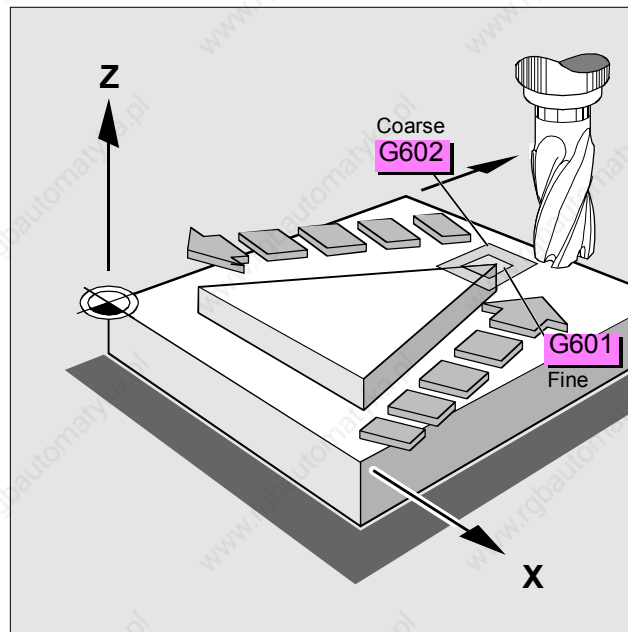

Producing sharp outside corners

Feedrate in continuous path mode, G64, G641

Programming

G64 Continuous path mode

G641 Block transition with contour transition rounding.
The rounding distance (in mm) is programmed via
ADIS = for G1, G2, G3 or
ADISPOS = for G0.

Both functions work with "look ahead" velocity control.

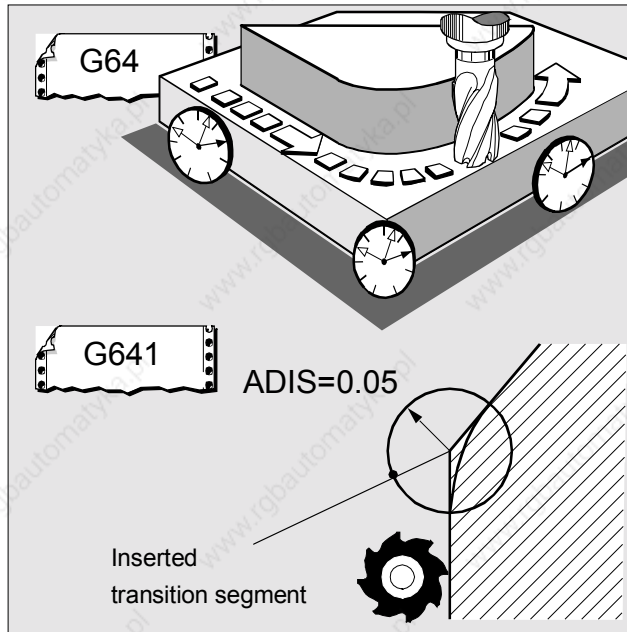

Optimization of the production results

Programming the spindle motion

Programming

```
N05 SETMS(2) LF
N10 G1 F300 X70 Y20 S270 M3 LF
```

Parameters

S, Sn	Spindle speed in rpm
M3, Mn=3	Clockwise rotation
M4, Mn=4	Counterclockwise rotation
M5, Mn=5	Spindle stop
SETMS(n)	Spindle n becomes master spindle
n	Spindle number



If the M commands are programmed in a block with axial motion, the commands before the axial motion are effective.

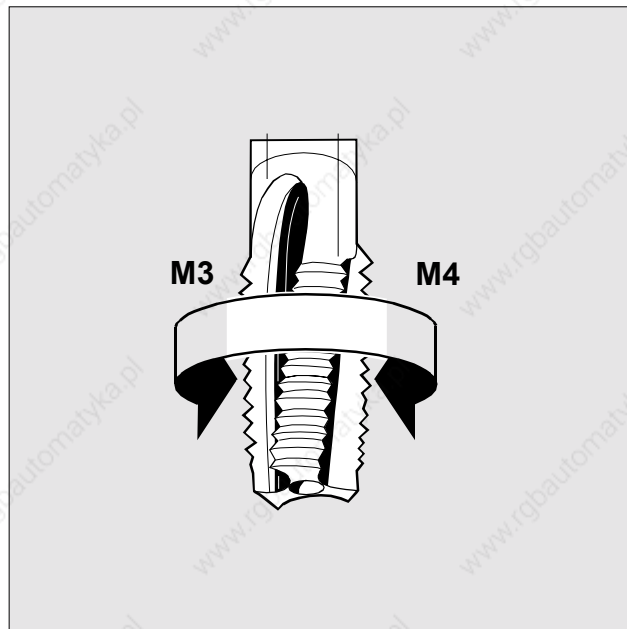

Programming the direction of spindle rotation

6. Subroutine Technique and Cycles

Subroutine technique	6-55
The use of cycles	6-57
Explanation of parameters	6-58
Drilling, centering, CYCLE81	6-62
Drilling, counterboring, CYCLE82	6-63
Deep hole drilling, CYCLE83	6-64
Rigid tapping, CYCLE84	6-65
Tapping with floating tapholder, CYCLE840	6-66
Bore 1, CYCLE85	6-67
Bore 2, CYCLE86	6-68
Bore 3, CYCLE87	6-69
Bore 4, CYCLE88	6-70
Bore 5, CYCLE89	6-71
Row of holes, HOLES1	6-72

Hole circle, HOLES2	6-73
Elongated holes on a circle, LONGHOLE	6-74
Slots on a circle, SLOT1	6-75
Circumferential slot, SLOT2	6-76
Rectangular pocket milling, POCKET1	6-77
Circular pocket milling, POCKET2	6-78
Thread cutting, CYCLE90	6-79
Recessing cycle, CYCLE93	6-80
Undercut cycle, CYCLE94	6-81
Stock removal cycle, CYCLE95	6-82
Thread undercut, CYCLE96	6-83
Thread cutting, CYCLE97	6-84
Chaining of threads, CYCLE98	6-85

Subroutine technique

Programming

```
N40 G0 X500 Y500 Z500 LF
N50 L230 P2 LF
```

L... Subroutine call
P... Number of repeats (max. 9999)

Subroutine nesting: nesting to a depth of eleven

The end of the subroutine and the return jump to the main program is programmed with M17. The subroutine must be called in a separate NC block.



Milling:

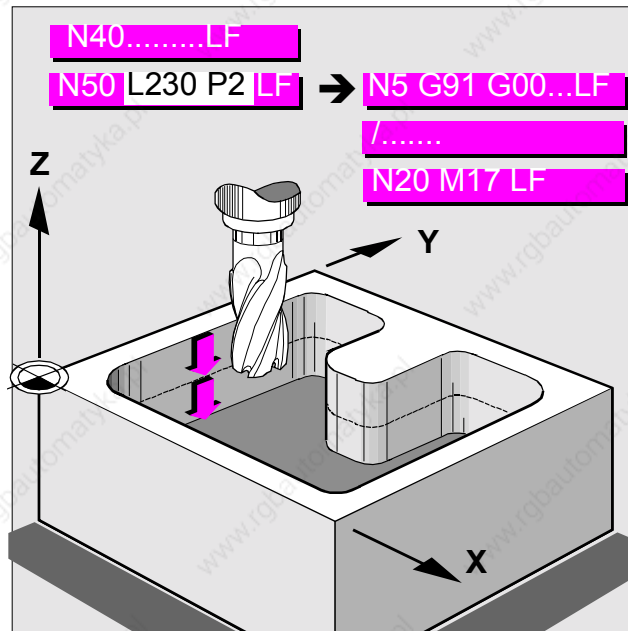

Machining in several steps

Subroutine technique (cont.)

Programming

```
N10 TRANS X0 Z150  
N20 L20  
N30 TRANS X0 Z140  
N40 L20  
N50 TRANS X0 Z130  
N60 L20
```

L... Subroutine call

Turning:

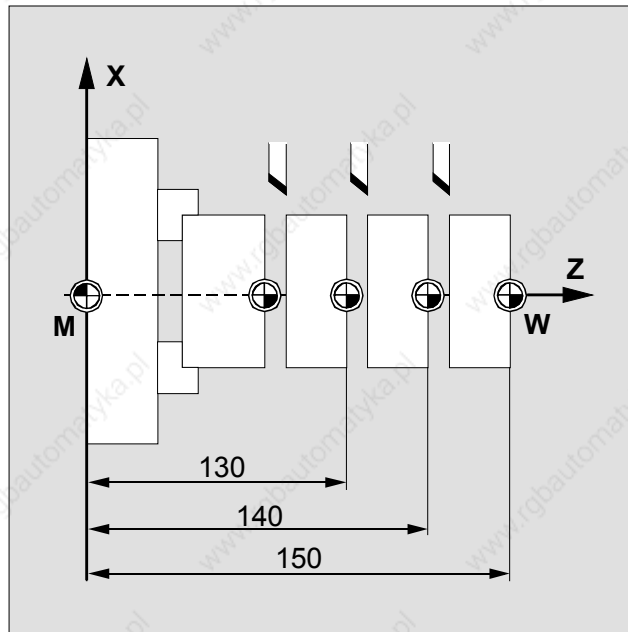

Machining in several steps

The use of cycles

Precondition

The machining plane (G17, G18, G19) feed and speed must be defined before calling the cycle.

Cycle call

Cycle calls must always be in a separate block!

For example:

CYCLE81 (RTP, RFP, SDID, DP, DPR) L_F

Programming support for cycles

The program editor in the control offers a programming support function for generating cycle calls.

You will find a detailed description of all cycles in the Programming Guides for the technologies turning and milling/drilling.

Explanation of parameters

Parameter	Explanation
AFSL	Angle for slot length (enter without sign)
ANG1	Flank angle 1: at the side of the groove defined by the start point (enter without sign) Values: $0 \leq \text{ANG1} < 89.999$ degrees
ANG2	Flank angle 2: at other side (enter without sign) Values: $0 \leq \text{ANG2} < 89.999$
APP	Run-in path (enter without sign)
CDIR	Direction of machining Values: 2 (for G2) 3 (for G3)
CPA	Center point circle/pocket abscissa (absolute)
CPO	Center point circle/pocket, ordinate (absolute)
CRAD	Corner radius (enter without sign)
DAM	CYCLE95: Path length after which each roughing cut is interrupted for chip breaking CYCLE83: Amount of depression (enter without sign)
DBH	Distance between holes (enter without sign)
DIAG	Groove depth (enter without sign)
DIATH	Nominal thread diameter, outer diameter of thread
DM1	Diameter of thread at start point
DM2	CYCLE97: Diameter of thread at end point CYCLE98: Diameter at first intermediate point
DM3	Diameter at second intermediate point
DM4	Diameter at end point
DP	Final drilling depth/elongated hole depth/slot depth/pocket depth (absolute)
DPR	Final drilling depth/elongated hole depth/slot depth/pocket depth relative to reference plane (enter without sign)
DT	Dwell time for chip breaking during roughing
DTB	CYCLE82, -83, -86, -88, -89: Dwell time at final drilling depth (chip breaking) CYCLE93: Dwell time at recess base CYCLE84, -840: Dwell time at thread depth (chip breaking) CYCLE85: Dwell time at drilling depth (chip breaking)
DTS	Dwell time at start point and for stock removal
ENC	Tapping with/without encoder Values: 0 = with encoder 1 = without encoder
FAL	Correct finishing allowance for contour (enter without sign)
FAL1	Finishing allowance at recess base
FAL2	Finishing allowance at edges
FALX	Finishing allowance in face axis (enter without sign)
FALZ	Finishing allowance in longitudinal axis (enter without sign)
FDEP	First drilling depth (absolute)

Explanation of parameters (cont.)

Parameter	Explanation
FDIS	Distance of first hole from reference point (enter without sign)
FDPR	First drilling depth relative to reference plane (enter without sign)
FF1	Feedrate for roughing without relief cut
FF2	Feedrate for insertion in relief cut elements
FF3	Feedrate for finishing
FFD	Feedrate for depth infeed
FFP1	Feedrate for surface machining
FFP2	Feedrate for final allowance
FFR	Feedrate
FORM	Definition of form CYCLE94: E (for Form E) F (for Form F) CYCLE96: A (for Form A) D (for Form D)
FPL	End point of thread in longitudinal axis
FRF	Feedrate factor for first drilling depth (enter without sign) Values: 0.001 ... 1
IANG	Insertion angle Values: "+" (for edge infeed) "-" (for alternating edge infeed)
IDEP	Insertion depth (enter without sign)
INDA	Indexing angle
KDIAM	Core diameter, inside diameter of thread
LENG	Length of elongated hole/slot length/pocket length (enter without sign)
MID	Maximum insertion depth for insertion (enter without sign)
MIDF	Maximum insertion depth for final allowance
MPIT	Thread pitch as thread size CYCLE97: 3 (for M3) ... 60 (for M60) CYCLE84, -840: 3 (for M3) ... 48 (for M48)
NID	Number of noncuts (enter without sign)
NPP	Name of the contour subprogram
NRC	Number of roughing cuts (enter without sign)
NSP	Start point offset for first thread start (enter without sign)
NUM	Number of holes/elongated holes/slots
NUMTH	Number of thread starts (enter without sign)
PIT	Thread pitch; values: 0.001 ... 2000.000 mm
PRAD	Pocket radius (enter without sign)
PO1	Start point of thread in the longitudinal axis
PO2	First intermediate point in the longitudinal axis

Explanation of parameters (cont.)

Parameter	Explanation
PO3	Second intermediate point
PO4	End point of thread in the longitudinal axis
POSS	Spindle position for oriented spindle stop in cycle (in degrees)
PP1	Thread pitch 1 as value (enter without sign)
PP2	Thread pitch 2 as value (enter without sign)
PP3	Thread pitch 3 as value (enter without sign)
PRAD	Pocket radius (enter without sign)
RAD	Radius of circle (enter without sign)
RCI1	Radius/chamfer 1, inside: at start point side
RCI2	Radius/chamfer 2, inside
RCO1	Radius/chamfer 1, outside: at the side defined by the start point
RCO2	Radius/chamfer 2, outside
RFF	Return feedrate
RFP	Reference plane (absolute)
ROP	Exit path (enter without sign)
RPA	Return path in abscissa of the active plane (enter incrementally with sign)
RPAP	Return plane in the applicate (enter incrementally with sign)
RPO	Return path in the ordinate of the active plane (enter incrementally with sign)
RTP	Return plane (absolute)
SDAC	Direction of rotation after end of cycle Values: 3, 4 or 5
SDIR	Direction of rotation Values: 3 (for M3) 4 (for M4)
SDIS	Safety distance (enter without sign)
SDR	Direction of rotation for return Values: 0 (automatic reversal of direction of rotation) 3 or 4 (for M3 or M4)
SPCA	Abscissa of a reference point on a straight line (absolute)
SPCO	Ordinate of this reference point (absolute)
SPD	Start point in the facing axis (enter without sign)
SPL	Start point of contour/thread in the longitudinal axis
SSF	Speed during finishing
SST	Speed for tapping
SST1	Speed for return
STA1	Starting angle Values: -180 to 180 degrees
TDEP	Thread depth (enter without sign)
TYPTH	Thread type: values: 0=inside thread 1=outside thread

Explanation of parameters (cont.)

Parameter	Explanation
VARI	Machining mode SLOT1, SLOT2, POCKET1, POCKET2: 0=complete machining 1=solid machining to finishing allowance 2=only machining of finishing allowance
CYCLE83:	0=chip breaking 1=stock removal
CYCLE93:	1...8 11...18
CYCLE95:	1...12
CYCLE97, CYCLE98:	1...4
WID	Slot width/pocket width (enter without sign)
WIDG	Slot width (enter without sign)

Drilling, centering, CYCLE81

Sequence The "Drilling, centering" cycle produces a simple hole.

Programming CYCLE81 (RTP, RFP, SDIS, DP, DPR)

RTP	Return plane (absolute)
RFP	Reference plane (absolute)
SDIS	Safety distance (enter without sign)
DP	Final drilling depth/elongated hole depth/slot depth/pocket depth (absolute)
DPR	Final drilling depth/elongated hole depth/slot depth/pocket depth relative to reference plane (enter without sign)

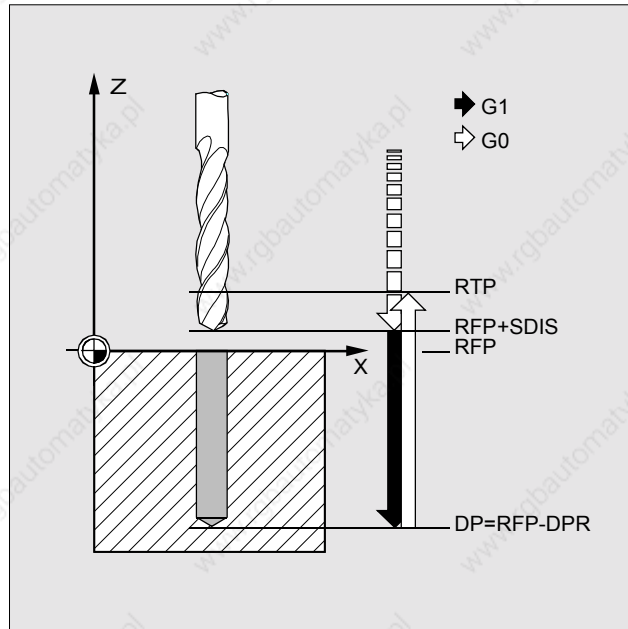

Sequence of motions and parameters in the "Drilling, centering" cycle

Drilling, counterboring, CYCLE82

Sequence

The "Drilling, counterboring" cycle produces a simple hole. When the final drilling depth has been reached, a dwell time can be activated.

Programming

CYCLE82 (RTP, RFP, SDIS, DP, DPR, DTB)

RTP	Return plane (absolute)
RFP	Reference plane (absolute)
SDIS	Safety distance (enter without sign)
DP	Final drilling depth/elongated hole depth/slot depth/pocket depth (absolute)
DPR	Final drilling depth/elongated hole depth/slot depth/pocket depth relative to reference plane (enter without sign)
DTB	CYCLE82: Dwell time at final drilling depth (chip breaking)

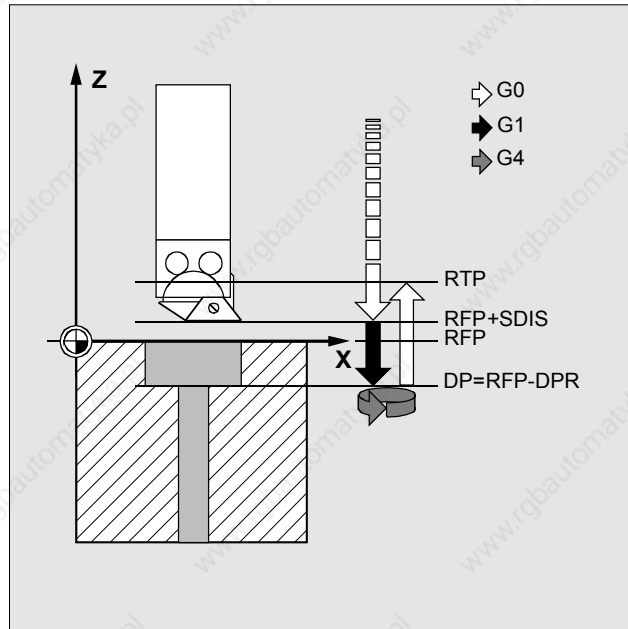

Sequence of motions and parameters in the "Drilling, counterboring" cycle

Deep hole drilling, CYCLE83

Sequence

The "Deep-hole drilling" cycle produces holes up to the final drilling depth by depth infeed in several steps the maximum amount of which can be programmed.

The drill can either be withdrawn from the reference plane after each infeed depth for stock removal or by 1 mm each time for chip breaking.

Programming

CYCLE83 (RTP, RFP, SDIS, DP, DPR, FDEP, FDPR, DAM, DTB, DTS, FRF, VARI)

RTP	Return plane (absolute)
RFP	Reference plane (absolute)
SDIS	Safety distance (enter without sign)
DP	Final drilling depth/elongated hole depth/slot depth/pocket depth (absolute)
DPR	Final drilling depth/elongated hole depth/slot depth/pocket depth relative to reference plane (enter without sign)
DTB	CYCLE82: Dwell time at final drilling depth (chip breaking)
FDEP	First depth (absolute)
	Other parameters: see Chapter "Explanation of parameters"

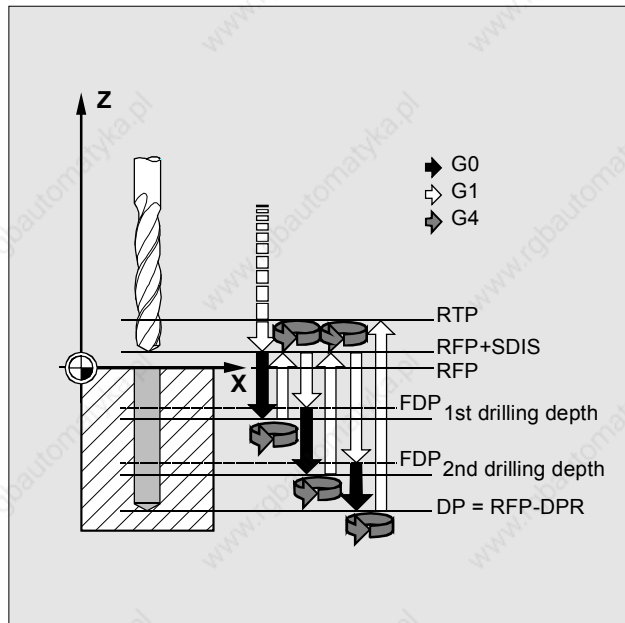

Sequence of motions and parameters in the "Deep-hole drilling" cycle with stock removal

Rigid tapping, CYCLE84

Sequence

CYCLE84 produces tapped holes without using a floating tapholder.



This cycle can be applied only if the spindle designated for drilling is capable of working in the position-controlled spindle mode.

Programming

CYCLE84 (RTP, RFP, SDIS, DP, DPR, DTB, SDAC, MPIT, PIT, POSS, SST, SST1)

RTP	Return plane (absolute)
RFP	Reference plane (absolute)
SDIS	Safety distance (enter without sign)
DP	Final drilling depth/elongated hole depth/slot depth/pocket depth (absolute)
DPR	Final drilling depth/elongated hole depth/slot depth/pocket depth relative to reference plane (enter without sign)
DTB	CYCLE82: Dwell time at final drilling depth (chip breaking) Other parameters: see Chapter "Explanation of parameters"

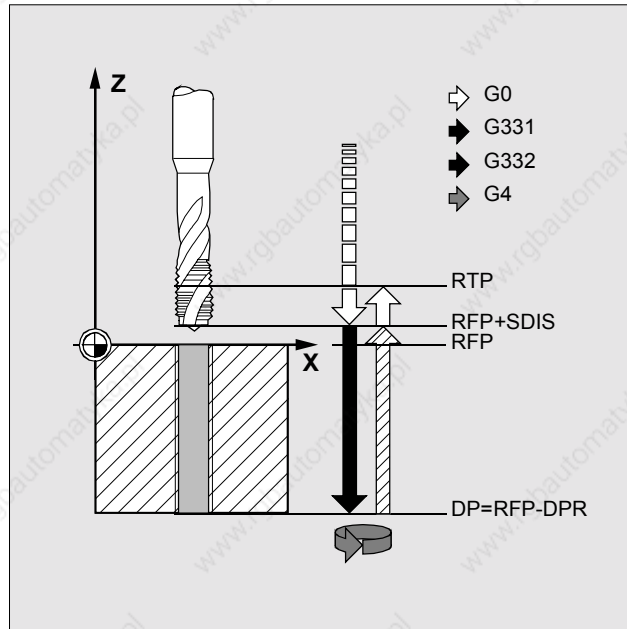

Sequence of motions and parameters in the "Rigid tapping" cycle

Tapping with floating tapholder, CYCLE840

Sequence

With this cycle, tapped holes can be produced with floating tapholder

- without encoder and
- with encoder.

For tapping without floating tapholder (rigid tapping) another cycle is used (CYCLE84, see previous page).

Programming

CYCLE840 (RTP, RFP, SDIS, DP, DPR, DTB, SDR, SDAC, ENC, MPIT, PIT)

RTP	Return plane (absolute)
RFP	Reference plane (absolute)
SDIS	Safety distance (enter without sign)
DP	Final drilling depth/elongated hole depth/slot depth/pocket depth (absolute)
DPR	Final drilling depth/elongated hole depth/slot depth/pocket depth relative to reference plane (enter without sign)
DTB	CYCLE82: Dwell time at final drilling depth (chip breaking) Other parameters: see Chapter "Explanation of parameters"

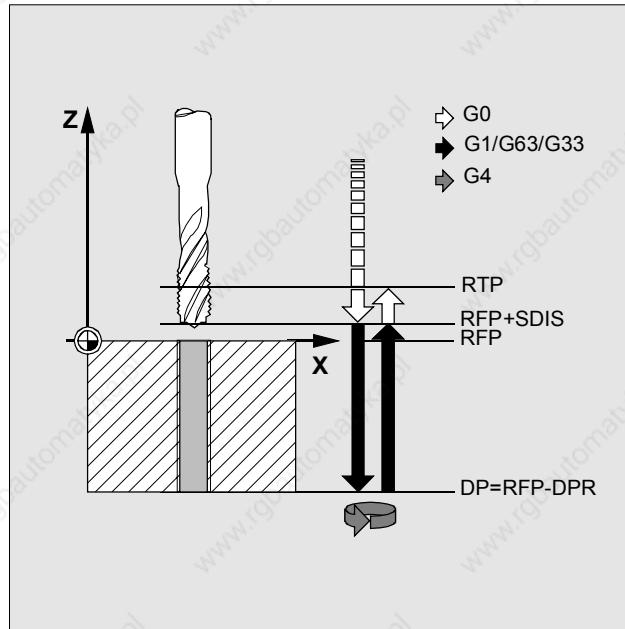

Sequence of motions and parameters in the "Tapping with floating tapholder/encoder" cycle

Bore 1, CYCLE85

Sequence

In the "Bore 1" cycle, the inward and outward motions are performed at a feedrate that must be specified under the relevant parameters.

Programming

CYCLE85 (RTP, RFP, SDIS, DP, DPR, DTB, FFR, RFF)

RTP	Return plane (absolute)
RFP	Reference plane (absolute)
SDIS	Safety distance (enter without sign)
DP	Final drilling depth/elongated hole depth/slot depth/pocket depth (absolute)
DPR	Final drilling depth/elongated hole depth/slot depth/pocket depth relative to reference plane (enter without sign)
DTB	CYCLE82: Dwell time at final drilling depth (chip breaking)
FFR	Feedrate
RFF	Return feedrate

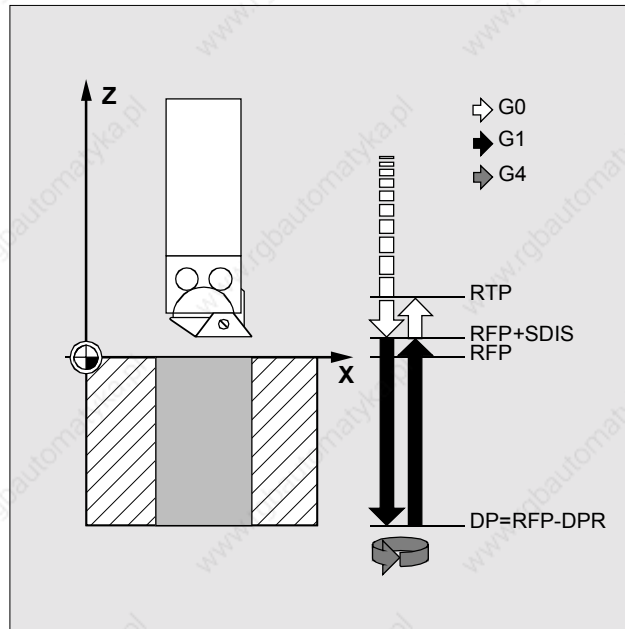

Sequence of motions and parameters in the "Bore 1" cycle

Bore 2, CYCLE86

Sequence

In the "Bore 2" cycle, an oriented spindle stop is performed on reaching the drilling depth. The tool then travels at rapid traverse to the programmed return positions and from there to the return plane.



This cycle can only be used if the spindle designated for drilling is technically capable of operating in the position-controlled spindle mode.

Programming

CYCLE86 (RTP, RFP, SDIS, DP, DPR, DTB, SDIR, RPA, RPO, RPAP, POSS)

RTP	Return plane (absolute)
RFP	Reference plane (absolute)
SDIS	Safety distance (enter without sign)
DP	Final drilling depth/elongated hole depth/slot depth/pocket depth (absolute)
DPR	Final drilling depth/elongated hole depth/slot depth/pocket depth relative to reference plane (enter without sign)
DTB	CYCLE82: Dwell time at Final drilling depth (chip breaking) Other parameters: see Chapter "Explanation of parameters"

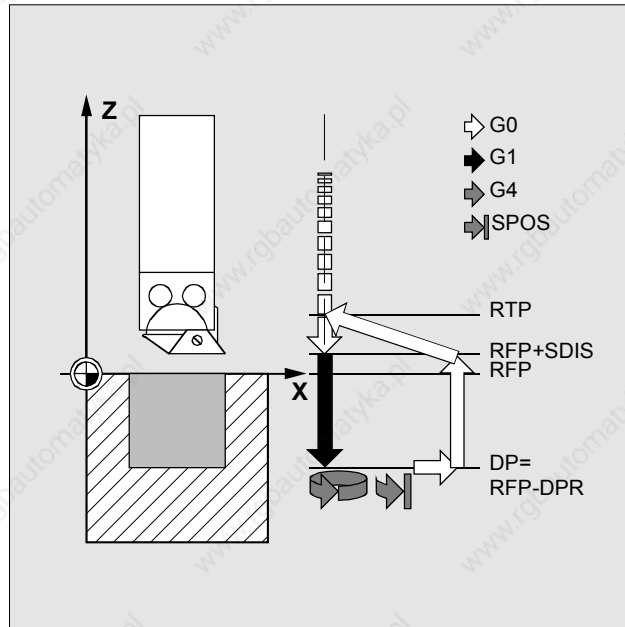

Sequence of motions and parameters in the "Bore 2" cycle

Bore 3, CYCLE87

Sequence

In the "Bore 3" cycle, a spindle stop without orientation is effected on reaching the final drilling depth, followed by a programmed stop. By pressing the NC Start key, the upwards movement is continued at rapid traverse until the retraction plane is reached.

Programming

CYCLE87 (RTP, RFP, SDIS, DP, DPR, SDIR)

RTP	Return plane (absolute)
RFP	Reference plane (absolute)
SDIS	Safety distance (enter without sign)
DP	Final drilling depth/elongated hole depth/slot depth/pocket depth (absolute)
DPR	Final drilling depth/elongated hole depth/slot depth/pocket depth relative to reference plane (enter without sign)
SDIR	Direction of rotation 3 (for M3) 4 (for M4)

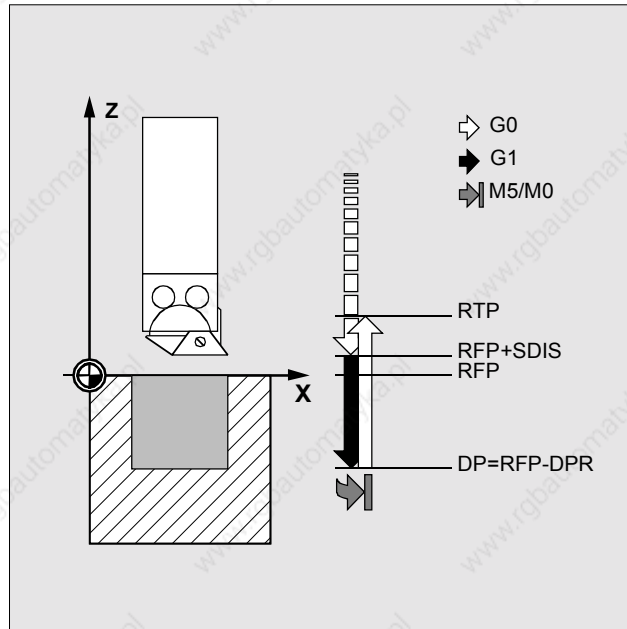

Sequence of motions and parameters in the "Bore 3" cycle

Bore 4, CYCLE88

Sequence

In the "Bore 4" cycle, a dwell time is effected on reaching the final drilling depth together with a spindle stop without orientation and a programmed stop. By pressing the NC Start key, the upwards movement is performed at rapid traverse until the retraction plane is reached.

Programming

CYCLE88 (RTP, RFP, SDIS, DP, DPR, DTB, SDIR)

RTP	Return plane (absolute)
RFP	Reference plane (absolute)
SDIS	Safety distance (enter without sign)
DP	Final drilling depth/elongated hole depth/slot depth/pocket depth (absolute)
DPR	Final drilling depth/elongated hole depth/slot depth/pocket depth relative to reference plane (enter without sign)
DTB	Dwell time at final drilling depth (chip breaking)
SDIR	Direction of rotation 3 (for M3) 4 (for M4)

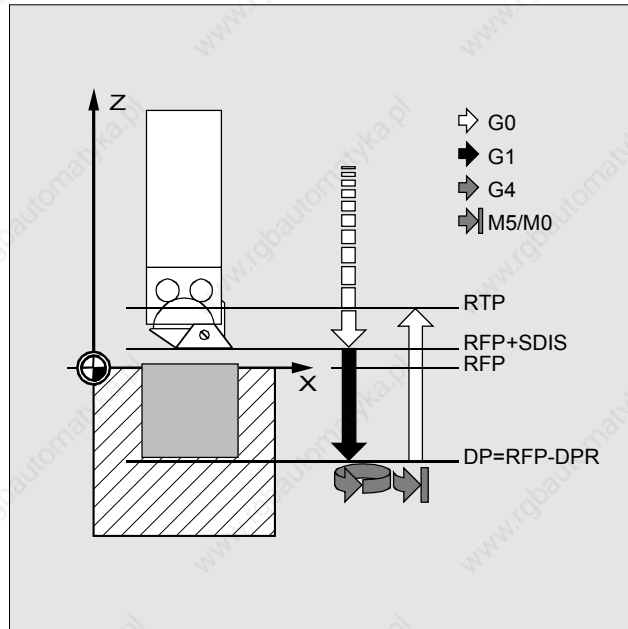

Sequence of motions and parameters in the "Bore 4" cycle

Bore 5, CYCLE89

Sequence

In the "Bore 5" cycle, the inwards and the upwards movements are performed at the F value programmed before the cycle call. On reaching the final drilling depth, a dwell time can be effected.

Programming

CYCLE89 (RTP, RFP, SDIS, DP, DPR, DTB)

RTP	Return plane (absolute)
RFP	Reference plane (absolute)
SDIS	Safety distance (enter without sign)
DP	Final drilling depth/elongated hole depth/slot depth/pocket depth (absolute)
DPR	Final drilling depth/elongated hole depth/slot depth/pocket depth relative to reference plane (enter without sign)
DTB	CYCLE82: Dwell time at final drilling depth (chip breaking)

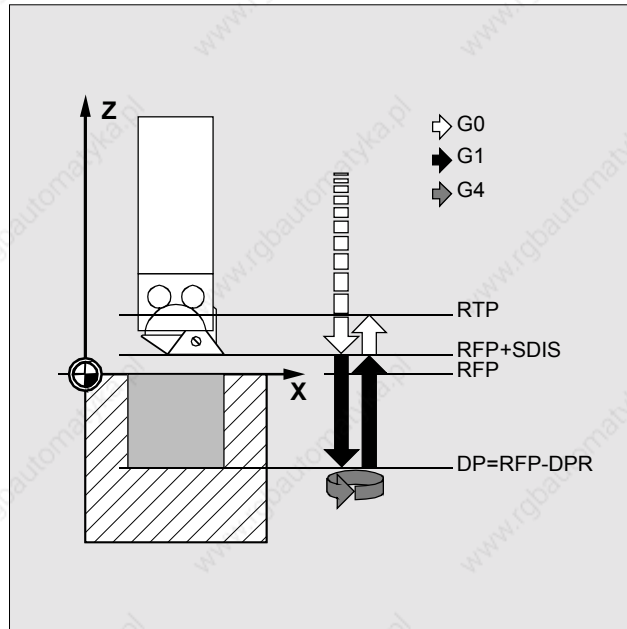

Sequence of motions and parameters in the "Bore 5" cycle

Row of holes, HOLES1

Sequence

With this cycle, a row of holes can be produced on a straight line.

Programming

HOLES1 (SPCA, SPCO, STA1, FDIS, DBH, NUM)

SPCA	Abscissa of a reference point on the straight line (absolute)
SPCO	Ordinate of this reference point (absolute)
STA1	Starting angle
	Values: -180 to 180 degrees
FDIS	Distance to first hole from reference point (enter without sign)
	(sign)
DBH	Distance between holes (enter without sign)
NUM	Number of holes/elongated holes/slots

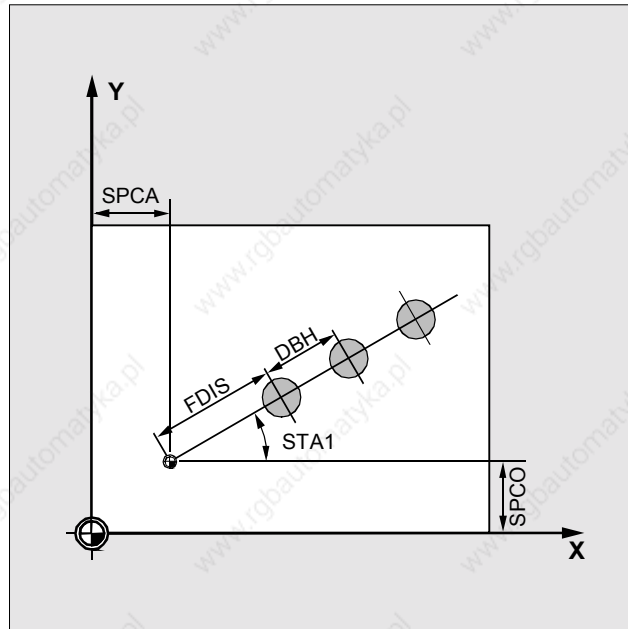

Parameters in the "Row of holes" drilling pattern

Hole circle, HOLES2

Sequence	With this cycle, a hole circle can be machined.
Programming	HOLES2 (CPA, CPO, RAD, STA1, INDA, NUM)
CPA	Center point circle/pocket, abscissa (absolute)
CPO	Center point circle/pocket, ordinate (absolute)
RAD	Radius of circle (enter without sign)
STA1	Starting angle Values: -180 to 180 degrees
INDA	Indexing angle
NUM	Number of holes/elongated holes/slots

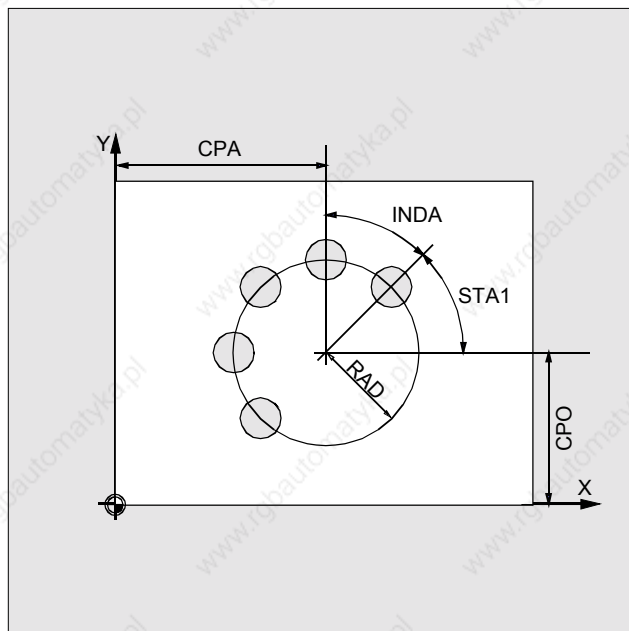

Parameters in the "Hole circle" drilling pattern

Elongated holes on a circle, LONGHOLE

Sequence

With this cycle, elongated holes can be produced arranged on a circle.
The width of the elongated hole is determined by the tool diameter.

Programming

LONGHOLE (RTP, RFP, SDIS, DP, DPR, NUM, LENG, CPA, CPO, RAD, STA1, INDA, FFD, FFP1, MID)

RTP	Return plane (absolute)
RFP	Reference plane (absolute)
SDIS	Safety distance (enter without sign)
NUM	Number of holes/elongated holes/slots
LENG	Length of elongated hole/slot length/pocket length (without sign)
CPA	Center point circle/pocket, abscissa (absolute)
CPO	Center point circle/pocket, ordinate (absolute)
RAD	Radius of circle (enter without sign)
STA1	Starting angle
	Values: -180 to 180 degrees
INDA	Indexing angle
	Other parameters: see Chapter "Explanation of parameters"

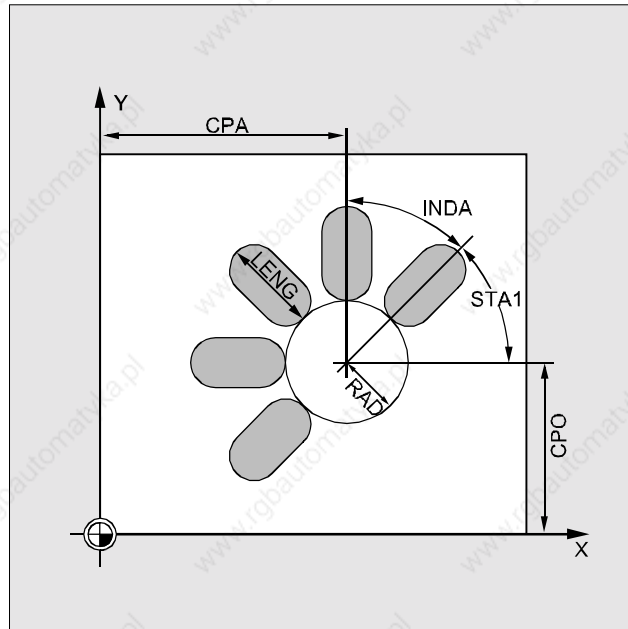

Parameters in the "Elongated holes on a circle" milling pattern

Slots on a circle, SLOT1

Sequence

With this cycle, slots can be produced arranged on a circle. The longitudinal axis of the slots has a radial orientation. In contrast to the elongated hole, a value is specified for the slot width. The SLOT1 cycle is a combined roughing/finishing cycle.

Programming

SLOT1 (RTP, RFP, SDIS, DP, DPR, NUM, LENG, WID, CPA, CPO, RAD, STA1, INDA, FFD, FFP1, MID, CDIR, FAL, VARI, MIDF, FFP2, SSF)

LENG	Length of elongated hole/slot length/pocket length (without sign)
WID	Slot width/pocket width (enter without sign)
CPA	Center point circle/pocket, abscissa (absolute)
CPO	Center point circle/pocket, ordinate (absolute)
RAD	Radius of circle (enter without sign)
STA1	Starting angle, values: -180 to 180 degrees
INDA	Indexing angle
	Other parameters: see Chapter "Explanation of parameters"

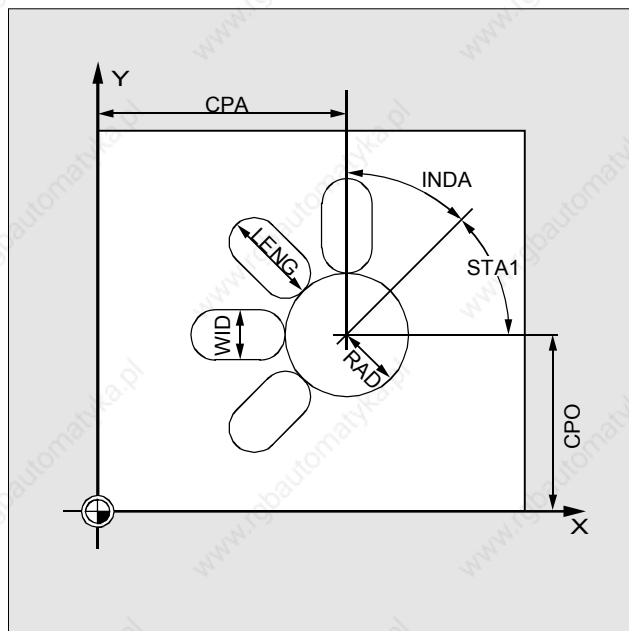

Parameters in the "Slots on a circle" milling pattern

Circumferential slot, SLOT2

Sequence

With this cycle, circular slots can be produced arranged on a circle.
The SLOT2 cycle is a combined roughing/finishing cycle.

Programming

SLOT2 (RTP, RFP, SDIS, DP, DPR, NUM, AFSL, WID, CPA, CPO, RAD, STA1, INDA, FFD, FFP1, MID, CDIR, FAL, VARI, MIDF, FFP2, SSF)

LENG	Length of elongated hole/slot length/pocket length (without sign)
WID	Slot width/pocket width (enter without sign)
CPA	Center point circle/pocket, abscissa (absolute)
CPO	Center point circle/pocket, ordinate (absolute)
RAD	Radius of circle (enter without sign)
STA1	Starting angle, Values: -180 to 180 degrees
INDA	Indexing angle
AFSL	Angle for slot length (enter without sign)
	Other parameters: see Chapter "Explanation of parameters"

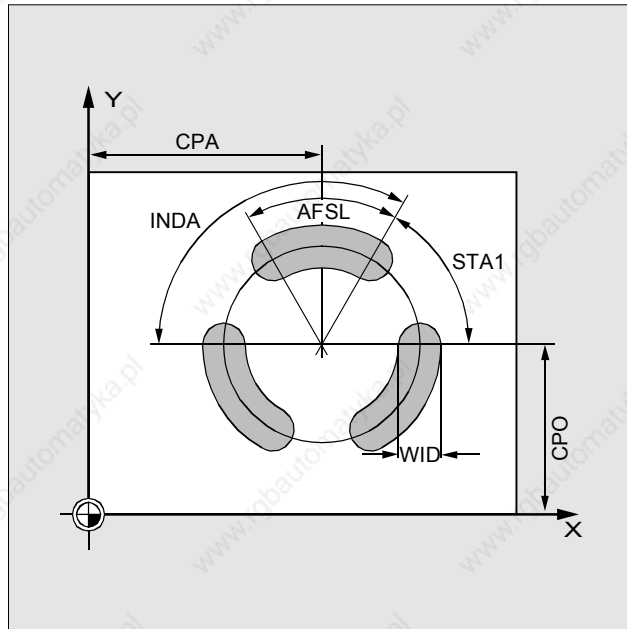

Parameters in the "Circumferential slot" milling pattern

Rectangular pocket milling, POCKET1

Sequence

With this cycle, rectangular pockets can be produced in any location in the machining plane.



The cycle is a combined roughing/finishing cycle.

Programming

POCKET1 (RTP, RFP, SDIS, DP, DPR, LENG, WID, CRAD, CPA, CPO, STA1, FFD, FFP1, MID, CDIR, FAL, VARI, MIDF, FFP2, SSF)

LENG

Length of elongated hole/slot length/pocket length (enter without sign)

WID

Slot width/pocket width (enter without sign)

CRAD

Corner radius (enter without sign)

CPA

Center point circle/pocket, abscissa (absolute)

CPO

Center point circle/pocket, ordinate (absolute)

STA1

Starting angle

Values: -180 to 180 degrees

Other parameters: see Chapter "Explanation of parameters"

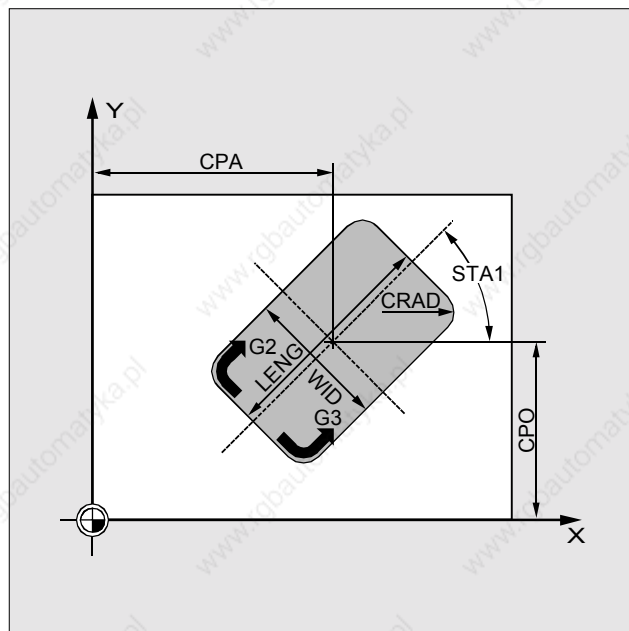

Parameters in the "Rectangular pocket" cycle

Circular pocket milling, POCKET2

Sequence

With this cycle, circular pockets can be produced.
The cycle is a combined roughing/finishing cycle.

Programming

POCKET2 (RTP, RFP, SDIS, DP, DPR, PRAD, CPA, CPO, CPO, FFD, FFP1, MID, CDIR, FAL, VARI, MIDF, FFP2, SSF)

RTP	Return plane (absolute)
RFP	Reference plane (absolute)
SDIS	Safety distance (enter without sign)
DP	Final drilling depth/elongated hole depth/slot depth/pocket depth (absolute)
DPR	Final drilling depth/elongated hole depth/slot depth/pocket depth relative to reference plane (enter without sign)
PRAD	Pocket radius (enter without sign)
CPA	Center point circle/pocket, abscissa (absolute)
CPO	Center point circle/pocket, ordinate (absolute)
FFD	Feedrate for depth infeed
FFP1	Feedrate for surface machining
MID	Maximum insertion depth (without sign)
CDIR	Direction of machining, 2 (for G2), 3 (for G3)
	Other parameters: see Chapter "Explanation of parameters"

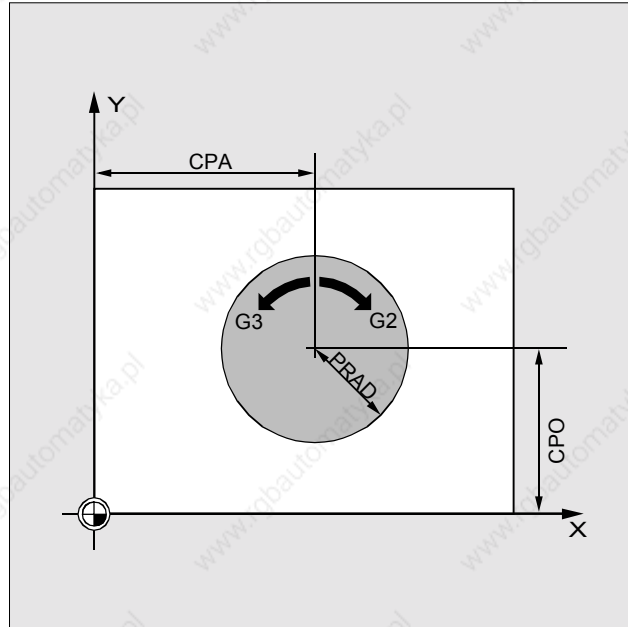

Parameters in the "circular pocket" cycle

Thread cutting, CYCLE90

Sequence

With this cycle, internal and external threads can be produced. The path in thread milling is based on helical interpolation.

All three geometry axes of the present plane are involved in this motion.

Programming

CYCLE90 (RTP, RFP, SDIS, DP, DPR, DIATH, KDIAM, PIT, FFR, CDIR, TYPTH, CPA, CPO)

RTP	Return plane (absolute)
RFP	Reference plane (absolute)
SDIS	Safety distance (enter without sign)
DP	Final drilling depth/elongated hole depth/slot depth/pocket depth (absolute)
DPR	Final drilling depth/elongated hole depth/slot depth/pocket depth relative to reference plane (enter without sign)
DIATH	Nominal thread diameter, outside diameter of thread
CDIR	Direction of machining: 2 (for G2), 3 (for G3)
CPA	Center point circle/pocket, abscissa (absolute)
CPO	Center point circle/pocket, ordinate (absolute)
	Other parameters: see Chapter "Explanation of parameters"

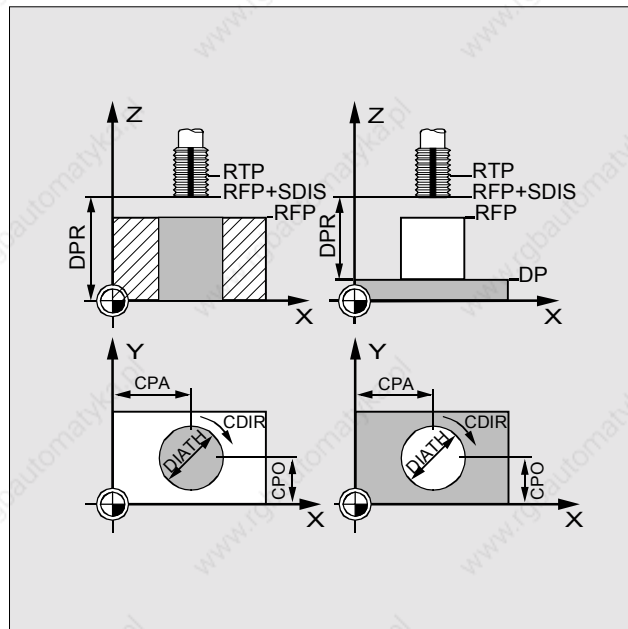

Parameters in the "Thread milling" cycle

Recessing cycle, CYCLE93

Sequence

The recessing cycle allows symmetrical and asymmetrical recesses to be produced for longitudinal and facing operations on any straight contour elements. Outside and inside recesses can be made.

Programming

SPD	CYCLE93 (SPD, SPL, WIDG, DIAG, STA1, ANG1, ANG2, RCO1, RCO2, RCI1, RCI2, FAL1, FAL2, IDEP, DTB, VARI)
SPL	Start point in the facing axis (enter without sign)
WIDG	Start point of contour/of thread in the longitudinal axis
DIAG	Slot width (enter without sign)
ANG1	Slot depth (enter without sign)
ANG2	Flank angle 1: at side of insertion defined by the start point (enter without sign)
RCO1	Flank angle 2: at other side (without sign)
RCO2	Radius/chamfer 1, outside: at side defined by start point
RCI1	Radius/chamfer 2, outside
RCI2	Radius/chamfer 1, inside: at start point side
	Radius/chamfer 2, inside
	Other parameters: see Chapter "Explanation of parameters"

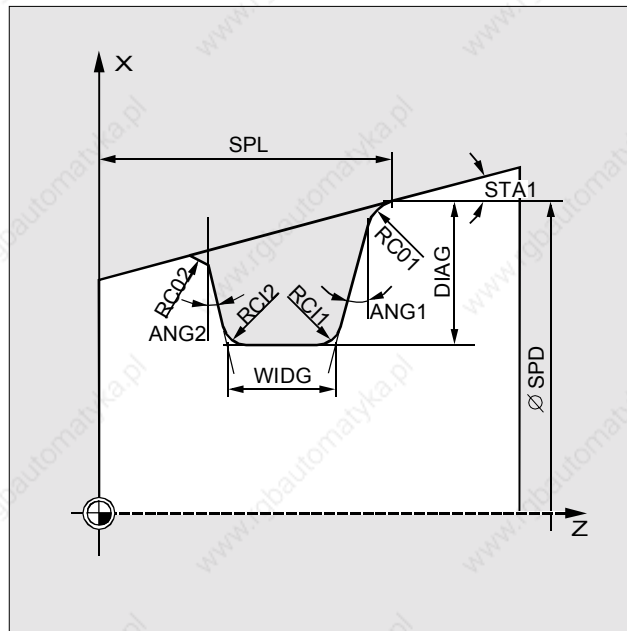

Parameters in the "Recessing" cycle for longitudinal machining

Undercut cycle, CYCLE94

Sequence

With this cycle, undercuts to DIN 509 of forms E and F can be produced with usual loading for a finished part diameter > 3 mm.

Programming

CYCLE94 (SPD, SPL, FORM)

SPD	Start point in the facing axis (enter without sign)
SPL	Start point of contour/of thread in the longitudinal axis
FORM	Definition of form E (for Form E) F (for Form F)

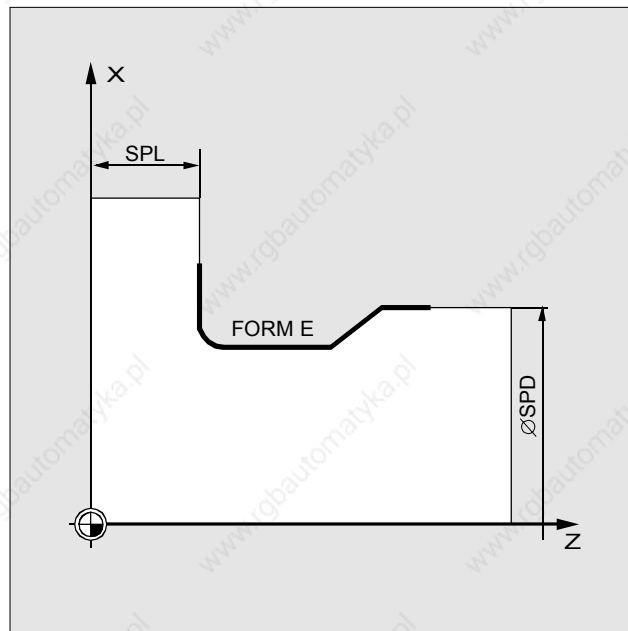

Parameters in the "Undercut" cycle

Stock removal cycle, CYCLE95

Sequence

With the "Stock removal" cycle, a contour programmed in a subroutine can be produced from a blank by means of paraxial stock removal. The contour can include relief-cut elements.

The technology (roughing/finishing/complete machining) is selectable. The cycle can be called from any collision-free position.

Programming

CYCLE95 (NPP, MID, FALZ, FALX, FAL, FF1, FF2, FF3, VARI, DT, DAM)

NPP	Name of the contour program
MID	Maximum insertion depth (enter without sign)
FALZ	Finishing allowance in the longitudinal axis (without sign)
FALX	Finishing allowance in the facing axis (without sign)
FAL	Correct finishing allowance for contour (without sign)
	Other parameters: see Chapter "Explanation of parameters"

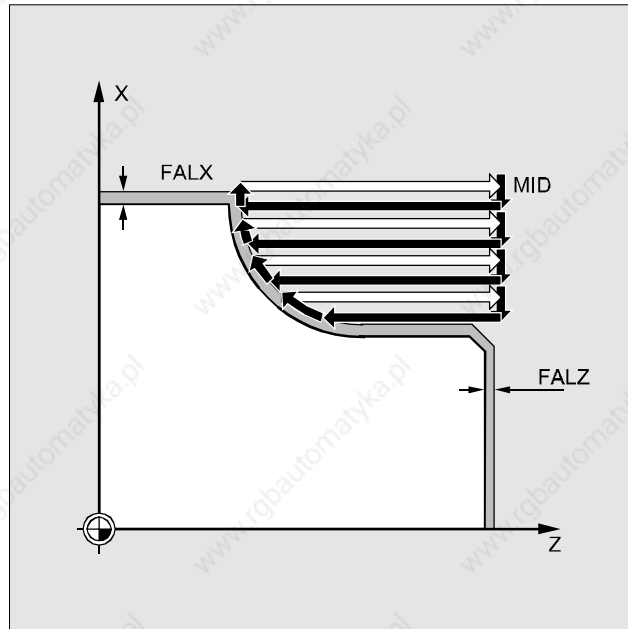

Sequence of motions and parameters in the "Stock removal" cycle

Thread undercut, CYCLE96

Sequence

With this cycle, form A, B, C, D thread undercuts can be produced in accordance with DIN 13 for parts with metric ISO thread.

Programming

CYCLE96 (DIATH, SPL, FORM)

DIATH

Rated diameter, outside diameter of thread

SPL

Start point of contour/of thread in the longitudinal axis

FORM

Definition of form E (for Form E)

F (for Form F)

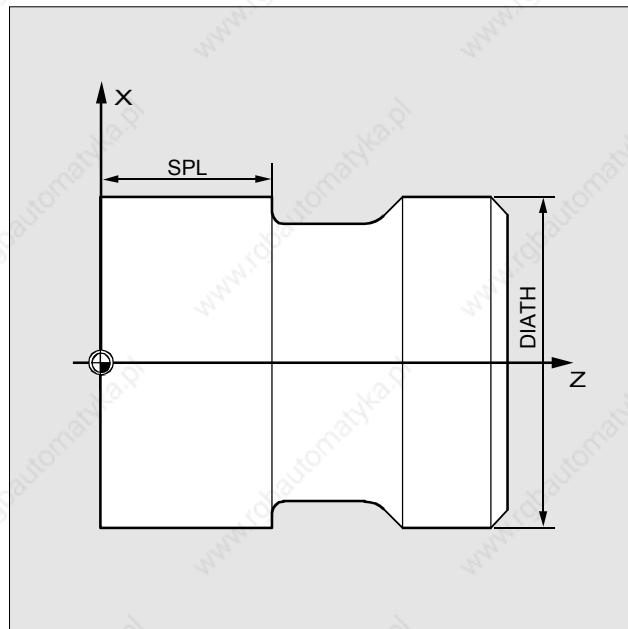

Parameters in the "Thread undercut" cycle

Thread cutting, CYCLE97

Sequence

With the "Thread cutting" cycle, cylindrical and tapered outside and inside threads can be produced in longitudinal and facing operations, both of the single thread and multiple thread type.

A prerequisite for using this cycle is a speed-controlled spindle with position measuring system. In the case of multiple threads, the individual threads are machined one after the other.

Programming

CYCLE97 (PIT, MPIT, SPL, FPL, DM1, DM2, APP, ROP, TDEP, FAL, IANG, NSP, NRC, NID, VARI, NUMTH)	
SPL	Start point of contour/thread in the longitudinal axis
FPL	End point of thread in the longitudinal axis
PIT	Pitch; Values: 0.001 ... 2000.000 mm
ROP	Exit path (enter without sign)
FAL	Correct finishing allowance for contour (enter without sign)
TDEP	Thread depth (enter without sign)
APP	Run-in path (enter without sign)
DM1	Diameter of thread at start point
DM2	Diameter of thread at end point
	Other parameters: see Chapter "Explanation of parameters"

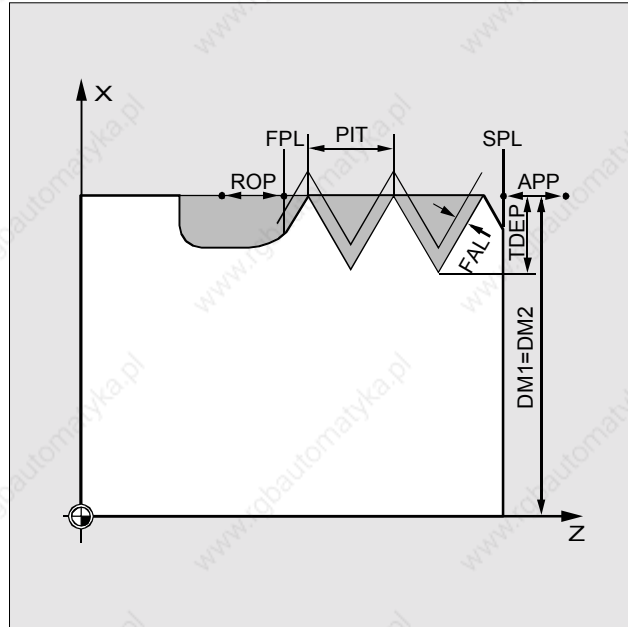

Parameters in the "Thread cutting" cycle

Chaining of threads, CYCLE98

Sequence

This cycle allows production in longitudinal and facing operations of several cylindrical or taper threads located one behind the other and possibly having different leads.

Programming

CYCLE98 (PO1, DM1, PO2, DM2, PO3, DM3, PO4, DM4, APP, ROP, TDEP, FAL, IANG, NSP, NRC, NID, PP1, PP2, PP3, VARI, NUMTH)

PO1	Start point of thread in the longitudinal axis
DM1	Diameter of thread at start point
PO2	First intermediate point in the longitudinal axis
DM2	Diameter at first intermediate point
PO3	Second intermediate point
DM3	Diameter at second intermediate point
PO4	End point of thread in the longitudinal axis
DM4	Diameter at end point
APP	Run-in path (enter without sign)
ROP	Exit path (enter without sign)
PP1 to PP3	Pitch 1 to 3 as value (enter without sign)
	Other parameters: see Chapter "Explanation of parameters"

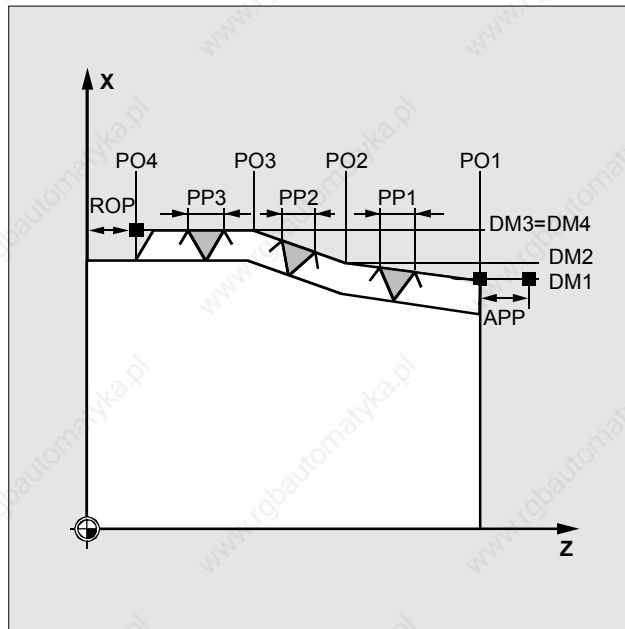

Parameters in the "Thread chaining" cycle

7. Predefined Switching and Auxiliary Functions

List of M commands 7-88

Forms 7-89

List of M commands

M0*	Programmed stop
M1*	Optional stop
M2*	End of program (main program)
M30*	End of program as M2
M17*	End of subroutine

M3	Spindle clockwise
M4	Spindle counterclockwise
M5	Spindle stop
M6	Tool change
M70	Change to axis mode

M40	Automatic gear change
M41	Gear stage 1
M42	Gear stage 2
M43	Gear stage 3
M44	Gear stage 4
M45	Gear stage 5

Extended address notation is not permissible for functions marked with an asterisk "".*



Machine manufacturer (MH7.1)

All free M function numbers can be assigned by the machine manufacturer. For example, with switching functions for controlling clamping devices or for activating/deactivating further machine functions.

Forms

You can enter your own user-specific functions here.

Forms

8. Program Key

List of G functions

8-92

List of G functions

Group 1: Modal motion commands				
Name	No.	Meaning	m/n	Def.
G0	1.	Rapid traverse motion	m	
G1	2.	Linear interpolation	m	Def.
G2	3.	Circular interpolation clockwise	m	
G3	4.	Circular interpolation counterclockwise	m	
CIP	5.	Circular interpolation through point	m	
ASPLINE #	6.	Akima spline	m	
BSPLINE #	7.	B spline	m	
CSPLINE #	8.	Cubic spline	m	
POLY ##	9.	Polynomial interpolation	m	
G33	10.	Thread cutting with constant lead	m	
G331	11.	Rigid tapping	m	
G332	12.	Return (rigid tapping)	m	
G58		Axial-programmable absolute zero offset	m	
G59		Axial-programmable additive zero offset	m	
OEMIPO1 ###	13.	OEM interpolation 1 *)	m	
OEMIPO2 ###	14.	OEM interpolation 2 *)	m	

*) The OEM user can include two additional types of interpolation. The OEM user can alter the names. If no function has been programmed out of this group for modal G functions, the default setting (which can be altered by machine data) applies: \$MC_GCODE_RESET_VALUES
 # Vocabulary word does **not** apply for SINUMERIK 810D; ## does **not** apply for SINUMERIK FM-NC/810D; ### does **not** apply for SINUMERIK 810D/FM-NC/NCU571

Group 2: Non-modal motion commands, dwell time				
G4	1.	Dwell time preset	n	
G63	2.	Tapping without synchronization	n	
G74	3.	Reference point approach with synchronization	n	
G75	4.	Fixed point approach	n	
REPOSL	5.	Repositioning on contour, linear	n	
REPOSQ	6.	Repositioning on contour in quarter circle	n	
REPOSH	7.	Repositioning on contour in semi-circle	n	
REPOSA	8.	Repositioning on contour with all axes	n	
REPOSQA	9.	Repositioning on contour with all axes, geometry axis in quarter circle	n	
REPOSHA	10.	Repositioning on contour with all axes, geometry axes in semi-circle	n	

m: modal, n: non-modal, Def.: Default

8-92

© Siemens AG 2000. All rights reserved.
 SINUMERIK 840D/810D/FM-NC Short Guide Programming (PGK) – 10.00 Edition

List of G functions

Group 3: Write memory				
Name	No.	Meaning	m/n	Def.
TRANS	1.	TRANSLATION: translation, programmable	n	
ROT	2.	ROTATION: rotation, programmable	n	
SCALE	3.	SCALE: scaling, programming	n	
MIRROR	4.	MIRROR: mirroring, programmable	n	
ATRANS	5.	Additive translation, programmable	n	
AROT	6.	Additive rotation, programmable	n	
ASCALE	7.	Additive scaling, programmable	n	
AMIRROR	8.	Additive mirroring, programmable	n	
TOFRAME	9.	Place currently programmed frame on tool coordinate system	n	
G25	10.	Minimum working area limitation/spindle speed limitation	n	
G26	11.	Maximum working area limitation/spindle speed limitation	n	
G110	12.	Pole programming relative to the last programmed setpoint position	n	
G111	13.	Pole programming relative to the zero of the present WCS	n	
G112	14.	Pole programming relative to the last valid pole	n	

Group 4: FIFO				
Name	No.	Meaning	m/n	Def.
STARTFIFO	1.	Execute and fill preprocessing buffer in parallel	m	Def.
STOPFIFO	2.	Stop processing: fill preprocessing memory	m	

Group 6: Plane selection				
Name	No.	Meaning	m/n	Def.
G17	1.	Plane selection 1st - 2nd geometry axis	m	Def.
G18	2.	Plane selection 3rd - 1st geometry axis	m	
G19	3.	Plane selection 2nd - 3rd geometry axis	m	

m: modal
n: Non-modal
Def.: Default

List of G functions

Group 7: Tool radius compensation				
Name	No.	Meaning	m/n	Def.
G40	1.	No tool radius compensation	m	
G41	2.	Tool radius compensation left of contour	m	
G42	3.	Tool radius compensation right of contour	m	

Group 8: Settable zero offset				
G500	1.	Deselection G54 - G5xx, reset settable frame	m	Def.
G54	2.	1st settable zero offset	m	
G55	3.	2nd settable zero offset	m	
G56	4.	3rd settable zero offset	m	
G57	5.	4th settable zero offset	m	
G5xx	nth	nth settable zero offset	m	
G599	100.	100th settable zero offset	m	

Group 9: Frame suppression				
G53	1.	Suppression of current frame	n	
SUPA	2.	Suppression of current zero offset, including programmed and handwheel offsets (DRF), external zero offset and PRESET offset		

Group 10: Exact stop, continuous path mode				
G60	1.	Velocity reduction, exact positioning	m	Def.
G64	2.	Continuous path mode	m	
G641	3.	Continuous path mode with programmable rounding distance	m	

Group 11: Exact stop blockwise				
G9	1.	Velocity reduction, exact stop	n	

m: modal
n: Non-modal
Def.: Default

List of G functions

Group 12: Block change criteria at exact stop (G60/G09)				
Name	No.	Meaning	m/n	Def.
G601	1.	Block change at exact stop fine	m	Def.
G602	2.	Block change at exact stop coarse	m	
G603	3.	Block change at end of interpolation block	m	

Group 13: Workpiece dimensioning inch/metric				
G70	1.	Input system inch	m	
G71	2.	Input system metric	m	Def.

Group 14: Workpiece dimensioning absolute/incremental				
G90	1.	Absolute dimension input	m	Def.
G91	2.	Incremental dimension input	m	

Group 15: Feedrate type				
G93 #	1.	Inverse time feedrate coding	m	
G94	2.	Linear feedrate in mm/min, inch/min	m	Def.
G95	3.	Revolutional feedrate in mm/rev, inch/rev	m	
G96	4.	Constant cutting velocity ON		
G97	5.	Constant cutting velocity OFF		

The vocabulary word does **not** apply for SINUMERIK FM-NC/810D.

Group 16: Feed correction at inside and outside curvature				
CFC	1.	Constant feed at contour	m	Def.
CFTCP	2.	Constant feed in tool center point	m	
CFIN	3.	Constant feed at inside curvature	m	

m: modal
n: Non-modal
Def.: Default

List of G functions

Group 17: Approach/retraction behavior, tool compensation				
Name	No.	Meaning	m/n	Def.
NORM	1.	Normal position at start/end point	m	Def.
KONT	2.	Travel around contour at start/end point	m	

Group 18: Corner behavior, tool compensation				
G450	1.	Transition circle	m	Def.
G451	2.	Intersection of equidistances	m	

Group 19: Curve transition at beginning of spline				
BNAT #	1.	Natural curve transition at the first spline block	m	Def.
BTAN #	2.	Tangential curve transition to the first spline block	m	
BAUTO #	3.	Definition of the 1st spline section through the following 3 points	m	

Group 20: Curve transition at end of spline				
ENAT #	1.	Natural curve transition to the next traversing block	m	Def.
ETAN #	2.	Tangential curve transition at the beginning of spline	m	
EAUTO #	3.	Definition of the last spline section through the last 3 points	m	

Group 21: Acceleration profile				
BRISK	1.	Brisk non-smoothed path acceleration	m	Def.
SOFT	2.	Soft smoothed path acceleration	m	
DRIVE ##	3.	Velocity-related path acceleration	m	

m: modal

n: Non-modal

Def.: Default

The vocabulary word does **not** apply for SINUMERIK 810D.

The vocabulary word applies **only** for SINUMERIK FM-NC.

List of G functions

Group 22: Tool compensation type				
Name	No.	Meaning	m/n	Def.
CUT2D	1.	2 1/2D tool compensation	m	Def.
CUT2DF	2.	2 1/2D tool compensation relative to current frame (inclined plane)	m	
CUT3DC #	3.	3D tool compensation peripheral milling	m	
CUT3DF #	4.	3D tool compensation peripheral milling	m	
CUT3DFS #	5.	3D tool compensation face milling with constant tool orientation, independent of active frame	m	
CUT3DFF #	6.	3D tool compensation face milling with constant tool orientation, independent of active frame	m	

The vocabulary word does **not** apply for SINUMERIK FM-NC/810D.

Group 23: Collision detection at inside contours				
Name	No.	Meaning	m/n	Def.
CDOF	1.	Collision detection off	m	Def.
CDON	2.	Collision detection on	m	

Group 24: Feedrate control				
Name	No.	Meaning	m/n	Def.
FFWOF	1.	Feedforward control off	m	Def.
FFWON	2.	Feedforward control on	m	

Group 25: Tool orientation				
Name	No.	Meaning	m/n	Def.
ORIWKS #	1.	Tool orientation in workpiece coordinate system	m	Def.
ORIMKS #	2.	Tool orientation in machine coordinate system	m	
ORIPATH #	3.	Tool orientation path	m	

The vocabulary word does **not** apply for SINUMERIK FM-NC/810D/NCU571.

Group 26: Repositioning point				
Name	No.	Meaning	m/n	Def.
RMB	1.	Return to start of block	m	
RMI	2.	Return to interruption point	m	Def.
RME	3.	Return to end of block	m	

m: modal
n: Non-modal
Def.: Default

List of G functions

Group 27: Tool compensation on change of orientation at outside corners				
Name	No.	Meaning	m/n	Def.
ORIC #	1.	Orientation changes are superimposed on the circle block to be inserted	m	Def.
ORID #	2.	Orientation changes are performed before the circle block	m	

Group 28: Working area limitation on/off				
WALIMON	1.	Working area limitation on	m	Def.
WALIMOF	2.	Working area limitation off	m	

Group 29: Radius – diameter				
DIAMOF	1.	Diameter programming off	m	Def.
DIAMON	2.	Diameter programming on	m	

Group 30: Compressor on/off				
COMPOF #	1.	Compressor off	m	Def.
COMPON #	2.	Compressor on	m	

Group 31: OEM - G group				
G810 #	1.	OEM G function		Def.
G811 #	2.	OEM G function		
G812 #	3.	OEM G function		
G813 #	4.	OEM G function		
G814 #	5.	OEM G function		
G815 #	6.	OEM G function		
G816 #	7.	OEM G function		
G817 #	8.	OEM G function		
G818 #	9.	OEM G function		
G819 #	10.	OEM G function		

Two groups are reserved for the OEM user who can use them to provide the end user with OEM functions in the final program. No.: Internal number for (e.g.) PLC interface. Def.: Default

The vocabulary word does **not** apply for SINUMERIK FM-NC/810D/NCU571.

m: Modal
n: Non-modal
Def.: Default

List of G functions

Group 32: OEM - G group				
G820 #	1.	OEM G function	m/s	Def.
G821 #	2.	OEM G function		Def.
G822 #	3.	OEM G function		
G823 #	4.	OEM G function		
G824 #	5.	OEM G function		
G825 #	6.	OEM G function		
G826 #	7.	OEM G function		
G827 #	8.	OEM G function		
G828 #	9.	OEM G function		
G829 #	10.	OEM G function		

Two groups are reserved for the OEM user who can use them to provide the end user with OEM functions in the final program.

No.: Internal number for (e.g.) PLC interface

m: Modal

n: Non-modal

Def.: Default

Group 33: Settable tool fine coding				
FTOCOF #	1.	Online active tool fine coding off	m	Def.
FTOCON #	2.	Online active tool fine coding on	m	

Group 34: Smoothing of tool orientation				
OSOF #	1.	Smoothing of tool orientation off	m	Def.
OSC #	2.	Constant smoothing of tool orientation	m	
OSS #	3.	Smoothing of tool orientation at end of block	m	
OSSE#	4.	Smoothing of tool orientation at beginning and end of block	m	

The vocabulary word does **not** apply for SINUMERIK FM-NC/810D/NCU571.

m: Modal

n: Non-modal

Def.: Default

List of G functions

Group 35: Punching and nibbling				
Name	No.	Meaning	m	Def.
SPOF #	1.	Punching, nibbling off	m	Def.
SON #	2.	Nibbling on	m	
PON #	3.	Punching on	m	
SONS #	4.	Nibbling on in IPO cycle	m	
PONS #	5.	Punching on in IPO cycle	m	

Group 36: Punching with delay				
PDELAYON #	1.	Punching with delay on	m	Def.
PDELAYOF #	2.	Punching with delay off	m	

Group 37: Feedrate profile				
FNORM #	1.	Feed normal in accordance with DIN66025	m	Def.
FLIN #	2.	Feed linear variable	m	
FCUB #	3.	Feed variable according to cubic spline		

Group 38: Assignment of high-speed NCK inputs/outputs for punching/nibbling				
SPIF1 #	1.	High-speed NCK inputs/outputs for punching/nibbling byte 1	m	Def.
SPIF2 #	2.	High-speed NCK inputs/outputs for punching/nibbling byte 2	m	

Group 39: Programmable contour accuracy				
CPRECOF	1.	Programmable contour accuracy off	m	Def.
CPRECON	2.	Programmable contour accuracy on	m	

The vocabulary word does **not** apply for SINUMERIK FM-NC/810D/NCU571.

No.: Internal number for (e.g.) PLC interface

m: Modal

n: Non-modal

Def.: Default

To:
SIEMENS AG
A&D MC BMS
P. O. Box 3180
D-91050 Erlangen
Federal Republic of Germany

Fax ++ 49 09131/98-1145)

From Name	Suggestions Corrections for Publication/Manual: SINUMERIK 840D/840Di SINUMERIK 810D/FM-NC User Documentation
Company/department Address <hr/> <hr/> Telephone / <hr/> Telefax: /	Short Guide Programming Order No.: 6FC5298-6AB30-0BP0 Edition: 10.00 Should you come across any printing errors when reading this publication, please notify us on this sheet. Suggestions for improvement are also welcome.

Suggestions and/or corrections