

Servomotors





4/2	Overview
4/4	Technical definitions for AC motors
4/14	1FT7 servomotors
	1FT7 Compact core type motors
4/16	Natural cooling
	1FT7 Compact motors
4/18	Natural cooling
4/22	Forced ventilation
4/24	Water cooling
	1FT7 High Dynamic motors
4/28	Forced ventilation/water cooling
4/30	1FK7 servomotors
	1FK7 Compact motors
4/34	Natural cooling
	1FK7 High Dynamic motors
4/38	Natural cooling
	1FK7 Compact/High Dynamic motors for 230 V 1 AC Power Modules
4/40	Natural cooling
	1FK7 High Inertia motors
4/42	Natural cooling
4/44	Selection guides
4/44	Holding brakes for 1FT7/1FK7 motors
4/45	Geared servomotors
4/46	1FT7 motors with SP+ planetary gearbox
4/50	1FK7 motors with SP+planetary gearbox
4/56	1FK7 motors with LP+planetary gearbox
4/58	1FK7-DYA compact geared motors
	Natural cooling
4/62	1FK7 geared servomotors
4/64	1FK7 helical geared motors
4/72	1FK7 offset-shaft geared motors
4/76	1FK7 bevel geared motors
4/82	1FK7 worm geared motors
4/95	Dimensional drawings
4/95	1FT7 Compact motors
4/99	1FT7 High Dynamic motors
4/102	1FK7 Compact motors
4/104	1FK7 High Dynamic motors
4/105	1FK7 High Inertia motors
4/106	1FT7 motors with SP+ planetary gearbox
4/109	1FK7 motors with SP+ planetary gearbox
4/116	1FK7 motors with LP+ planetary gearbox
4/117	1FK7-DYA motors
Part 14	CAD CREATOR
	Dimension drawing and 2D/3D CAD generator
	www.siemens.com/cadcreator

Servomotors

Overview

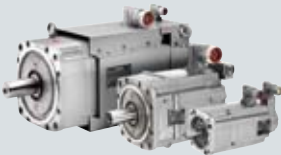
4





Motor type	Features	Degree of protection	Cooling method
1FT7 servomotors 	1FT7 Compact servomotor Permanent-magnet synchronous servomotor	IP64 (optional IP65, IP67)	Natural cooling Forced ventilation Water cooling
	1FT7 High Dynamic servomotor Permanent-magnet synchronous servomotor Very low rotor moment of inertia	IP64 (optional IP65, IP67)	Forced ventilation Water cooling
1FK7 servomotors 	1FK7 Compact servomotor Permanent-magnet synchronous servomotor	IP64 (optional IP65)	Natural cooling
	1FK7 High Dynamic servomotor Permanent-magnet synchronous servomotor Very low rotor moment of inertia	IP64 (optional IP65)	Natural cooling
	1FK7 High Inertia servomotor Permanent-magnet synchronous servomotor Increased rotor moment of inertia	IP64 (optional IP65)	Natural cooling

Geared servomotors

Page

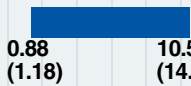
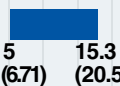
1FT7 servomotors with SP+ planetary gearbox	4/45
1FK7 servomotors with SP+ planetary gearbox	4/50
1FK7 servomotors with LP+ planetary gearbox	4/56
1FK7-DYA compact geared motors with planetary gearbox	4/58
1FK7 servomotors with helical gearbox	4/64
1FK7 servomotors with offset-shaft gearbox	4/72
1FK7 servomotors with bevel gearbox	4/76
1FK7 servomotors with worm gearbox	4/82

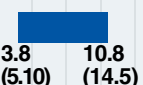
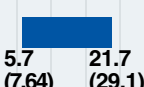
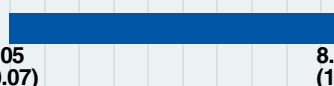
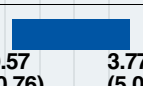
The selection and ordering data for the SINAMICS S120 Motor Modules are based on the booksize format by way of example. Other formats are also possible. The SIZER configuration tool is available for detailed configuration.

Shaft height	Rated power P_{rated} for S1 duty kW (HP)	Rated torque M_{rated}	Page
SH 36/SH 48/SH 63/ SH 80/SH 100	 0.88 (1.18) 10.5 (14.1)	1.4 ... 61 Nm (12.4 ... 540 lb _f -in)	4/16
SH 80/SH 100	 5 (6.71) 15.3 (20.5)	21 ... 73 Nm (186 ... 646 lb _f -in)	4/22
SH 63/SH 80/SH 100	 3.1 (4.16) 34.2 (45.9)	9.2 ... 125 Nm (81.4 ... 1106 lb _f -in)	4/24
SH 63/SH 80	 3.8 (5.10) 10.8 (14.5)	11 ... 33 Nm (97.4 ... 292 lb _f -in)	4/28
SH 63/SH 80	 5.7 (7.64) 21.7 (29.1)	16.5 ... 51 Nm (146 ... 451 lb _f -in)	4/28
SH 20/SH 28/SH 36/SH 48/ SH 63/SH 80/SH 100	 0.05 (0.07) 8.17 (11.0)	0.08 ... 37 Nm (0.7 ... 327 lb _f -in)	4/34
SH 36/SH 48/SH 63/SH 80	 0.57 (0.76) 3.77 (5.06)	0.9 ... 18 Nm (8 ... 159 lb _f -in)	4/38
SH 48/SH 63/SH 80	 0.9 (1.21) 3.1 (4.16)	1.5 ... 15 Nm (13.3 ... 133 lb _f -in)	4/42

Servomotors

Technical definitions for AC motors

Overview

Regulations, standards and specifications

The motors comply with the appropriate standards and regulations, see table below.

As a result of the fact that in many countries the national regulations have been completely harmonized with the international IEC 60034-1 recommendation, there are no longer any differences with respect to coolant temperatures, temperature classes and temperature rise limits.

General specifications for rotating electrical machines	IEC 60034-1
Terminal designations and direction of rotation for electrical machines	IEC 60034-8
Types of construction of rotating electrical machines	IEC 60034-7
Cooling methods of rotating electrical machines	IEC 60034-6
Degrees of protection of rotating electrical machines	IEC 60034-5
Vibration severity of rotating electrical machines	IEC 60034-14
Noise limit values for rotating electrical machines	IEC 60034-9
Cylindrical shaft extensions for electrical machines	DIN 748-3/IEC 60072-1

The motors listed below are UL-approved by Underwriters Laboratories Inc. and also comply with Canadian cUR standards: 1FK7/1FT7/1FW3/1PH7 (without brake)/1PH8 (without brake)/1PL6.

Degrees of protection for AC motors

A suitable degree of protection must be selected to protect the machine against the following hazards depending on the relevant operating and environmental conditions:

- Ingress of water, dust and solid foreign objects;
- Contact with or approach to rotating parts inside a motor and
- Contact with or approach to live parts.

Degrees of protection of electric motors are specified by a code. This comprises 2 letters, 2 digits and, if required, an additional letter.

IP (International Protection)

Code letter designating the degree of protection against contact and the ingress of solid foreign objects and water

0 to 6

1st digit designating the degree of touch protection and protection against ingress of solid foreign objects

0 to 8

2nd digit designating the degree of protection against ingress of water (no oil protection)

W, S and M

Additional code letters for special degrees of protection

Most motors are supplied with the following degrees of protection:

Motor	Degree of protection	1st digit: Touch protection	Protection against foreign objects	2nd digit: Protection against water
Internally cooled	IP23	Protection against finger contact	Protection against medium-sized, solid foreign objects above 12 mm Ø	Protection against spray water up to 60° from the vertical
Surface-cooled	IP54	Complete protection against accidental contact	Protection against harmful dust deposits	Splash water from any direction
	IP55			Jet-water from any direction
	IP64	Complete protection against accidental contact	Protection against dust ingress	Splash water from any direction
	IP65¹⁾			Jet-water from any direction
IP67¹⁾			Motor under specified pressure and time conditions under water	

Recommended degrees of protection for AC motors

When cooling lubricants are used, protection against water alone is inadequate. The IP rating should only be considered here as a guideline. The motors may have to be protected by suitable covers. Attention must be paid to providing suitable sealing of the motor shaft for the selected degree of protection for the motor (for 1FT7: degree of protection IP67 and flange 0).

The table can serve as a decision aid for selecting the proper degree of protection for motors. A permanent covering of liquid on the flange must be avoided when the motor is mounted with the shaft extension facing upwards (IM V3, IM V19).

Effect	Liquids General workshop environment	Water; gen. cooling lubricant (95% water, 5% oil)
Dry	IP64	–
Water-enriched environment/ increased humidity	–	IP64
Mist	–	IP65
Spray	–	IP65
Jet	–	IP67
Splash/ brief immersion/ constant inundation	–	IP67

¹⁾ DIN VDE 0530 Part 5 or EN 60034 Part 5 specifies that there are only 5 degrees of protection for the first digit code and 8 degrees of protection for the second digit code in relation to rotating electrical machinery. However, IP6 is included in DIN 40050 which generally applies to electrical equipment.

Overview (continued)

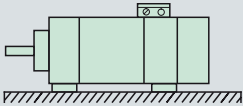
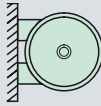
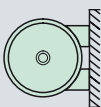
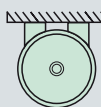
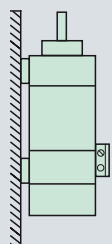
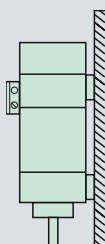
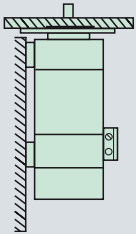
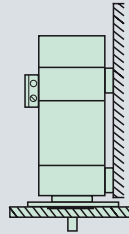
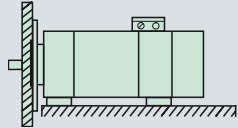
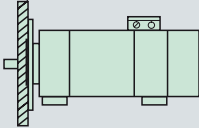
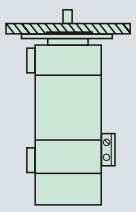
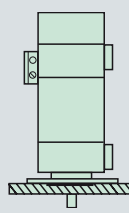
Types of construction/mounting positions	Types of construction/mounting positions
<p>IM B3</p> 	<p>IM B6</p> 
<p>IM B7</p> 	<p>IM B8</p> 
<p>IM V6</p> 	<p>IM V5</p> 
<p>IM V35¹⁾</p> 	<p>IM V15¹⁾</p> 
<p>IM B35¹⁾</p> 	<p>IM B5</p> 
<p>IM V3</p> 	<p>IM V1</p> 

¹⁾ Fixing on the flange and feet is necessary.

Servomotors

Technical definitions for AC motors

Overview (continued)

Radial eccentricity tolerance of shaft in relation to housing axis refers to cylindrical shaft extensions

Shaft height SH	Tolerance N mm (in)	Tolerance R mm (in)
28/36	0.035 (0.0014)	0.018 (0.0007)
48/63	0.04 (0.0016)	0.021 (0.0008)
80/100/132	0.05 (0.0020)	0.025 (0.0010)
160/180/225	0.06 (0.0024)	0.03 (0.0012)
280	0.07 (0.0028)	0.035 (0.0014)
355	0.08 (0.0031)	0.04 (0.0016)

Test: radial eccentricity

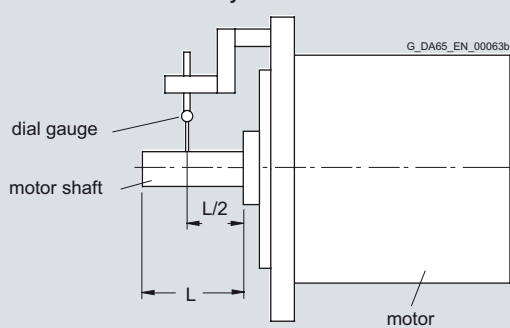

Concentricity and axial eccentricity tolerance of the flange surface to the shaft axis referred to the centering diameter of the mounting flange

Shaft height SH	Tolerance N mm (in)	Tolerance R mm (in)
28/36/48	0.08 (0.0031)	0.04 (0.0016)
63/80/100	0.1 (0.0039)	0.05 (0.0020)
132/160/180/225	0.125 (0.0049)	0.063 (0.0025)
280/355	0.16 (0.0063)	0.08 (0.0031)

Test: concentricity

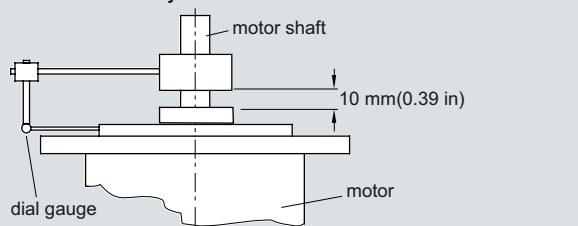

Test: axial eccentricity

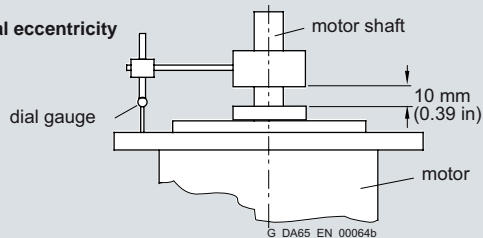

Vibration severity and vibration magnitude grade A according to IEC 60034-14

The vibration severity is the RMS value of the vibration velocity (frequency range from 10 to 1000 Hz). The vibration severity is measured using electrical measuring instruments in compliance with DIN 45666.

The values indicated refer only to the motor. These values can increase as a result of the overall system vibrational behavior due to installation.

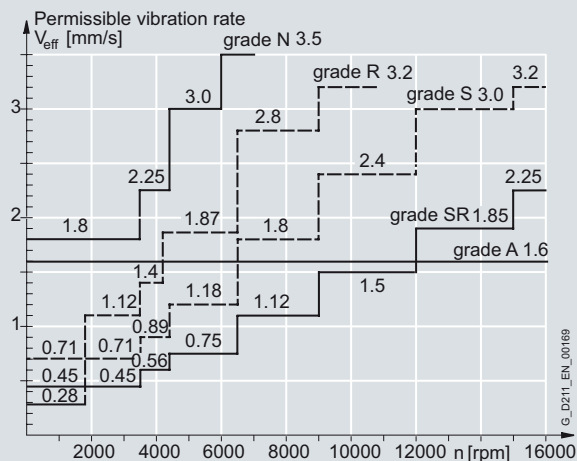

Vibration severity limit values for shaft heights 20 to 132

The speeds of 1800 rpm and 3600 rpm and the associated limit values are defined in accordance with IEC 60034-14. Speeds of 4500 rpm and 6000 rpm and the specified values are defined by the motor manufacturer.

The motors maintain vibration magnitude Grade A up to rated speed.

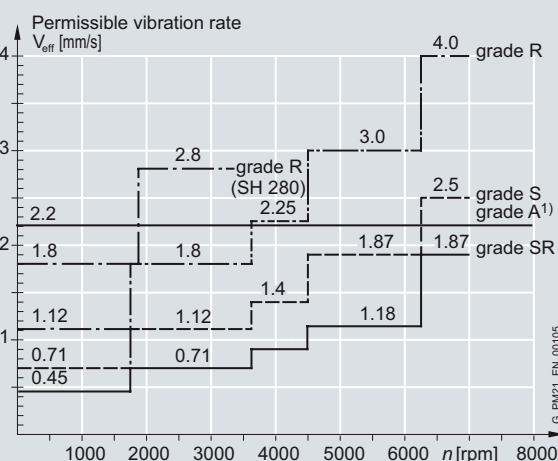

¹⁾ For 1PH8 motors with SH 355, the vibration magnitude is grade A: 2.8 mm/s.

Vibration severity limit values for shaft heights 160 to 355

Overview (continued)

Balancing in accordance with DIN ISO 8821

In addition to the balance quality of the motor, the vibration quality of motors with mounted belt pulleys and coupling is essentially determined by the balance quality of the mounted component.

If the motor and mounted component are separately balanced before they are assembled, then the process used to balance the belt pulley or coupling must be adapted to the motor balancing type. The following different balancing methods are used on motors of types 1PH8/1PH7/1PL6:

- Half-key balancing
- Full-key balancing
- Plain shaft extension

The letter H (half key) or F (full key) is printed on the shaft extension face to identify a half-key balanced or a full-key balanced 1PH8/1PH7/1PL6 motor.

1FT7/1FK7 motors with fitted key are always half-key balanced.

In general, motors with a plain shaft are recommended for systems with the most stringent vibrational quality requirements. For full-key balanced motors, we recommend belt pulleys with two opposite keyways, but only one fitted key in the shaft extension.

Vibration stress, immitted vibration values

The following maximum permissible vibration stress limits at full functionality apply only to 1FT7/1FK7 permanent-magnet servomotors and 1FW3 torque motors.

Vibration stress in accordance with DIN ISO 10816:

- 1 g at 20 Hz to 2 kHz

The following limits are valid for (immitted) vibration values introduced externally to all 1PH8/1PH7/1PL6 main motors:

Vibration frequency	Vibration values for 1PH808/1PH810/1PH813/1PH816	
< 6.3 Hz	Vibration displacement s	$\leq 0.16 \text{ mm (0.01 in)}$
6.3 ... 250 Hz	Vibration speed V_{rms}	$\leq 4.5 \text{ mm/s (0.18 in/s)}$
> 250 Hz	Vibration acceleration a	$\leq 10 \text{ m/s}^2 (32.8 \text{ ft/s}^2)$

Vibration frequency	Vibration values for 1PH818/1PH822/1PH828/1PH835 1PH718/1PH722/1PH728 1PL618/1PL622/1PL628	
< 6.3 Hz	Vibration displacement s	$\leq 0.25 \text{ mm (0.01 in)}$
6.3 ... 63 Hz	Vibration velocity V_{rms}	$\leq 7.1 \text{ mm/s (0.28 in/s)}$
> 63 Hz	Vibration acceleration a	$\leq 4.0 \text{ m/s}^2 (13.1 \text{ ft/s}^2)$

The following limits are valid for (immitted) vibration values introduced externally to all complete torque motors of type 1FW3:

Vibration frequency	Vibration values for 1FW3	
< 6.3 Hz	Vibration displacement s	$\leq 0.26 \text{ mm (0.01 in)}$
6.3 ... 63 Hz	Vibration speed V_{am}	$\leq 7.1 \text{ mm/s (0.28 in/s)}$
> 63 Hz	Vibration acceleration a	$\leq 4.0 \text{ m/s}^2 (13.1 \text{ ft/s}^2)$

Coolant temperature (ambient temperature) and installation altitude

Operation (unrestricted): -15 °C to +40 °C (5 °F to 104 °F)

The rated power (rated torque) is applicable to continuous duty (S1) in accordance with EN 60034-1 at rated frequency, a coolant temperature of 40 °C (104 °F) and an installation altitude of 1000 m (3281 ft) above sea level.

Apart from the 1PH8 motors, all motors are in temperature class 155 (F) and utilized in accordance with temperature class 180 (H). The 1PH8 motors are designed for temperature class 180 (H). For all other conditions, the factors given in the table below must be applied to determine the permissible output (torque).

The coolant temperature and installation altitude are rounded to 5 °C and 500 m (1640 ft) respectively.

Installation altitude above sea level m (ft)	Coolant temperature (ambient temperature)			
	< 30 °C (86 °F)	30 ... 40 °C (86 ... 104 °F)	45 °C (113 °F)	50 °C (122 °F)
1000 (3281)	1.07	1.00	0.96	0.92
1500 (4922)	1.04	0.97	0.93	0.89
2000 (6562)	1.00	0.94	0.90	0.86
2500 (8203)	0.96	0.90	0.86	0.83
3000 (9843)	0.92	0.86	0.82	0.79
3500 (11484)	0.88	0.82	0.79	0.75
4000 (13124)	0.82	0.77	0.74	0.71

Servomotors

Technical definitions for AC motors

Overview (continued)

Duty types S1 and S6 in accordance with EN 0530

S1: Continuous duty

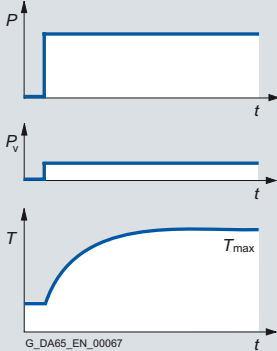

Duty cycle under constant load condition of sufficient duration to establish thermal equilibrium.

Designation: S1
Output specification (torque).

G_DA65_EN_00067

S6: Continuous duty with intermittent loading

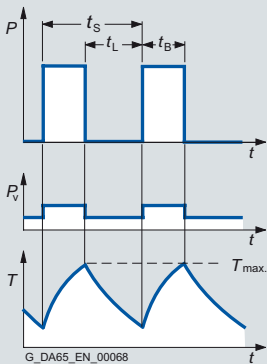

Duty cycle comprising a sequence of identical duty cycles, each of which consists of a period of constant load followed by an interval at no load. There are no de-energized intervals.

Designation:
e.g.: S6 - 40 %, 85 kW.
(114 HP).

$$t_r = \frac{t_B}{t_B + t_L}$$

$$t_s = 10 \text{ min}$$

G_DA65_EN_00068

Rated torque

The torque supplied on the shaft is indicated in Nm (lb_f-ft) in the selection and ordering data.

$$M_{\text{rated}} = 9.55 \times P_{\text{rated}} \times \frac{1000}{n_{\text{rated}}}$$

P_{rated} Rated power in kW

n_{rated} Rated speed in rpm

M_{rated} Rated torque in Nm

$$M_{\text{rated}} = P_{\text{rated}} \times \frac{5250}{n_{\text{rated}}}$$

P_{rated} Rated power in HP

n_{rated} Rated speed in rpm

M_{rated} Rated torque in lb_f-ft

DURIGNIT IR 2000 insulation system

The DURIGNIT IR 2000 insulation system consists of high-quality enamel wires and insulating sheeting in conjunction with a solvent-free resin impregnation.

This ensures that these motors will have a high mechanical and electrical strength, high service value and a long service life.

The insulation system protects the winding to a large degree against aggressive gases, vapors, dust, oil and increased air humidity. It can withstand the usual vibration stressing.

Overview (continued)

Motor protection

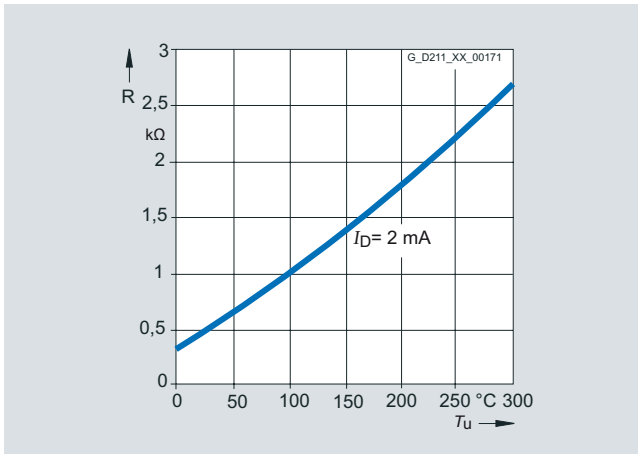

The KTY84-130 temperature sensor is used to measure the motor temperature for converter-fed motor operation.

This sensor is a semi-conductor that changes its resistance depending on temperature in accordance with a defined curve.

Siemens converters determine the motor temperature using the resistance of the temperature sensor.

Their parameters can be set for specific alarm and shutdown temperatures.

The KTY84-130 temperature sensor is embedded in the winding overhang of the motor like a PTC thermistor.

The sensor is evaluated in the SINAMICS S120 drive system as a standard function.

If the motors are operated on converters that do not feature a KTY84 evaluation circuit, the temperature can be measured with the external 3RS1040 temperature monitoring relay. For a detailed description, please see Catalog IC 10 or Siemens Industry Mall:

www.siemens.com/industrymall

Paint finish

Motors without a paint finish have an impregnated resin coating. Motors with primer have corrosion protection.

All motors can be painted over with commercially available paints. Up to 2 additional paint coats are permissible.

Version	Suitability of paint finish for climate group in accordance with IEC 60721, Part 2-1
Paint finish	Moderate (expanded) for indoor and outdoor installation with roof protection Briefly Up to 150 °C (302 °F) Continuously: Up to 120 °C (248 °F)
Special paint finish	Worldwide (expanded) for outdoor installation Briefly Up to 150 °C (302 °F) Continuously Up to 120 °C (248 °F) Also For corrosive atmospheres up to 1 % acid and alkali concentration or permanent dampness in sheltered rooms

Servomotors

Technical definitions for AC motors

Overview (continued)

Built-in encoder systems without DRIVE-CLiQ interface

For motors without an integrated DRIVE-CLiQ interface, the analog encoder signal in the drive system is converted to a digital signal. For these motors as well as external encoders, the encoder signals must be connected to SINAMICS S120 via Sensor Modules.

Built-in encoder systems with DRIVE-CLiQ interface

For motors with an integrated DRIVE-CLiQ interface, the analog encoder signal is internally converted to a digital signal. There is no further conversion of the encoder signal in the drive system. The motor-internal encoders are the same encoders that are used for motors without a DRIVE-CLiQ interface. Motors with a DRIVE-CLiQ interface simplify the commissioning and diagnostics, for example, due to automatic identification of the encoder system.

The different encoder types, incremental, absolute or resolver, are uniformly connected with one type of MOTION-CONNECT DRIVE-CLiQ cable.

Short designations for the encoder systems

The first letters of the short designation define the encoder type. This is followed by the resolution in signals per revolution if S/R is specified (for encoders without DRIVE-CLiQ interface) or in bits if DQ is specified (for encoders with DRIVE-CLiQ interface).

Examples:

Type	Resolution/interface	
AM AS IC IN HTL	xxxxSR	Encoder <u>without</u> DRIVE-CLiQ interface Resolution = xxxx signals per revolution
AM AS IC IN R	xxDQ	Encoder <u>with</u> DRIVE-CLiQ interface Resolution = xx bit (2^{xx})
AM	Absolute encoder, multi-turn	
AS	Absolute encoder, single-turn	
IC	Incremental encoder sin/cos with commutation position C and D tracks	
IN	Incremental encoder sin/cos without commutation position	
HTL	Incremental encoder with HTL signal	
R	Resolver	

Overview of the motor encoder systems

Encoder without DRIVE-CLiQ interface	Encoder with DRIVE-CLiQ interface	Absolute position within a rotation (single-turn)	Absolute position over 4096 revolutions (multi-turn)	For use in safety applications ¹⁾	Identification letter in the motor order number (without DRIVE-CLiQ interface)					Identification letter in the motor order number (with DRIVE-CLiQ interface)				
					1F7	1FK7	1FW3	1PH8	1PH7	1F7	1FK7	1FW3	1PH8	1PH7
AM2048S/R	AM22DQ	Yes	Yes	Yes	M	E	E	E	E	F	F	F	F	F
AM512S/R	AM20DQ	Yes	Yes	Yes	–	H	–	–	–	–	L	–	–	–
AM32S/R	AM16DQ	Yes	Yes	No	–	G	–	–	–	–	K	–	–	–
AM16S/R	AM15DQ	Yes	Yes	No	–	J	–	–	–	–	V	–	–	–
AS2048S/R	AS22DQ	Yes	No	No	–	–	N	–	–	–	–	P	–	–
IC2048S/R	IC22DQ	No	No	Yes	N	A	A	M	M	D	D	D	D	D
IN2048S/R	IN22DQ	No	No	Yes	–	–	–	–	N	–	–	–	–	Q
HTL1024S/R	–	No	No	No	–	–	–	H	H	–	–	–	–	–
HTL2048S/R	–	No	No	No	–	–	–	J	J	–	–	–	–	–
Resolver p=1	R14DQ	Yes	No	No	–	T	–	–	–	–	P	–	–	–
Resolver p=3	R15DQ	No	No	No	–	S	S	–	–	–	U	U	–	–
Resolver p=4	R15DQ	No	No	No	–	S	S	–	–	–	U	U	–	–

Not every encoder is available for every motor frame size.

– Not possible

¹⁾ Not for 1FW3 motors.

Overview (continued)

Multi-turn absolute encoder

This encoder outputs an absolute angular position between 0° and 360° in the specified resolution. An internal measuring gearbox enables it to differentiate 4096 rotations.

With a ball screw, for example, the absolute position of the slide can be determined over a long distance.

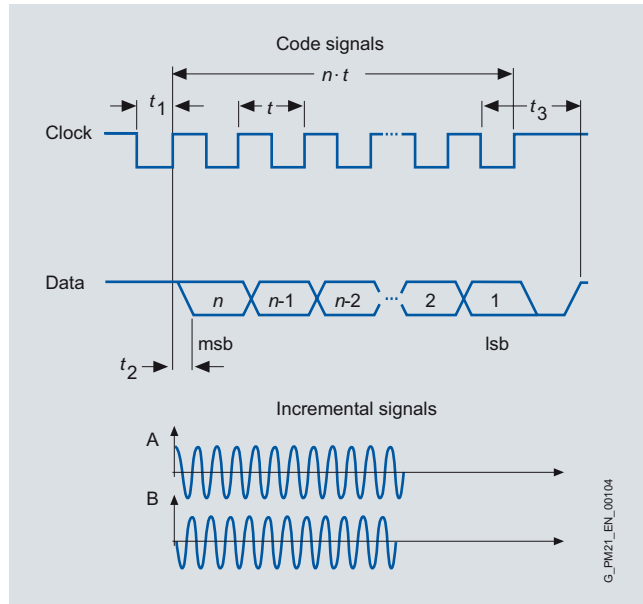

Multi-turn absolute encoder

Single-turn absolute encoder

This encoder outputs an absolute angular position between 0° and 360° in the specified resolution. In contrast to the multi-turn absolute encoder, it has no measuring gearbox and can therefore only supply the position value within one revolution. It does not have a traversing range.

Absolute encoder without DRIVE-CLiQ interface

AM2048S/R	Absolute encoder 2048 S/R, 4096 revolutions, multi-turn, with EnDat interface
AM512S/R	Absolute encoder 512 S/R, 4096 revolutions, multi-turn, with EnDat interface
AM32S/R	Absolute encoder 32 S/R, 4096 revolutions, multi-turn, with EnDat interface
AM16S/R	Absolute encoder 16 S/R, 4096 revolutions, multi-turn, with EnDat interface
AS2048S/R	Absolute encoder single-turn 2048 S/R

Absolute encoder with DRIVE-CLiQ interface

AM22DQ	Absolute encoder, 22 bit + 12 bit multi-turn
AM20DQ	Absolute encoder, 20 bit + 12 bit multi-turn
AM16DQ	Absolute encoder, 16 bit + 12 bit multi-turn
AM15DQ	Absolute encoder, 15 bit + 12 bit multi-turn
AS22DQ	Absolute encoder, single-turn, 22 bit

Technical specifications

Angular error	
• AM2048S/R and AM22DQ	± 40"
• AM512S/R and AM20DQ	± 120"
• AM32S/R and AM16DQ	± 280"
• AM16S/R and AM15DQ	± 480"
• AS2048S/R and AS22DQ	± 40"

Absolute encoder without DRIVE-CLiQ interface

Supply voltage	5 V
Absolute position interface via EnDat	
• Traversing range (multi-turn) ¹⁾	4096 revolutions
Incremental signals (sinusoidal, 1 V _{pp})	
• Signals per revolution	2048/512/32/16

Absolute encoder with DRIVE-CLiQ interface

Supply voltage	24 V
Absolute position via DRIVE-CLiQ	
• Resolution within one revolution	2 ²² /2 ²⁰ /2 ¹⁶ /2 ¹⁵ bit
• Traversing range (multi-turn) ¹⁾	4096 revolutions

¹⁾ Not for absolute encoder, single-turn AS.

Servomotors

Technical definitions for AC motors

Overview (continued)

Incremental encoder

This encoder senses relative movements and does not supply absolute position information. In combination with evaluation logic, a zero point can be determined via the integrated reference mark, which can be used in turn to calculate the absolute position.

Incremental encoder IC/IN (sin/cos)

The encoder outputs sine and cosine signals. These can be interpolated using evaluation logic (usually 2048 points) and the direction of rotation can be determined.

In the version with DRIVE-CLiQ interface, this evaluation logic is already integrated in the encoder.

Commutation position

The position of the rotor is required for commutation of a synchronous motor. Encoders with commutation position (also termed C and D track) detect the angular position of the rotor.

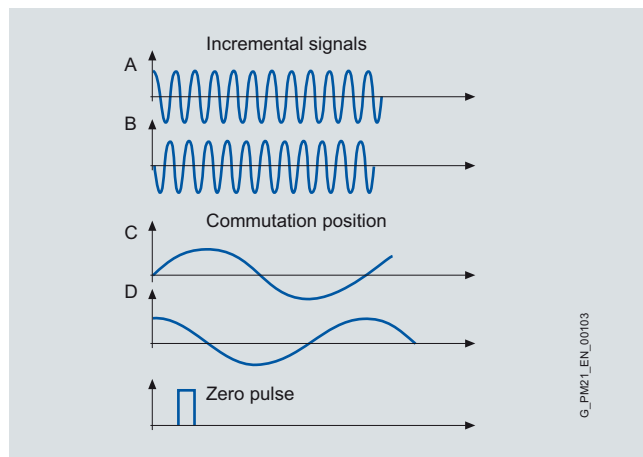

Incremental encoder IC/IN (sin/cos), commutation position for IC only

HTL incremental encoder

The encoder outputs square wave signals. The direction of rotation can be evaluated by means of edge evaluation.

The resolution is four times the number of encoder pulses. This encoder type is preferred for long signal cables.

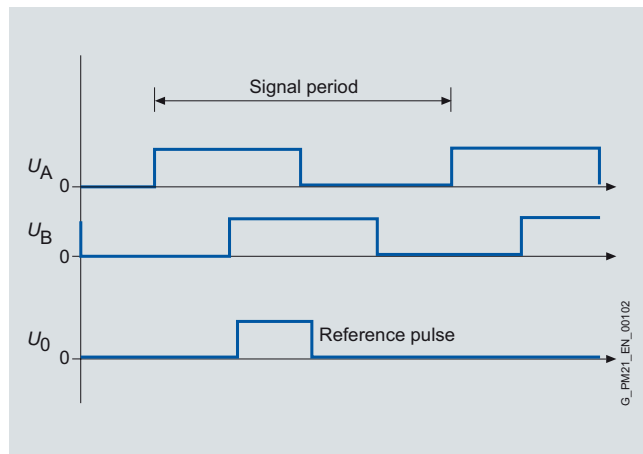

HTL incremental encoder

Incremental encoder without DRIVE-CLiQ interface

IC2048S/R	Incremental encoder sin/cos 1 V _{pp} 2048 S/R with C and D track
IN2048S/R	Incremental encoder sin/cos 1 V _{pp} , 2048 S/R without C or D tracks
HTL2048S/R	Incremental encoder HTL 2048S/R
HTL1024S/R	Incremental encoder HTL 1024S/R

Incremental encoder with DRIVE-CLiQ interface

IC22DQ	Incremental encoder 22 bit (resolution 4194304, internal 2048 S/R) + commutation position 11 bit
IN22DQ	Incremental encoder 22 bit (resolution 4194304, internal 2048 S/R) without commutation position

Technical specifications

Angular error	
• IC2048S/R and IC22DQ	± 40°
• IN2048S/R and IN22DQ	± 120°
• HTL2048S/R	± 60°
• HTL1024S/R	± 60°

Incremental encoder IC/IN (sin/cos) without DRIVE-CLiQ interface

Supply voltage	5 V
Incremental signals per revolution	
• Resolution (sin/cos)	2048
• Commutation position (for IC only)	1 sin/cos
• Reference signal	1

Incremental encoder IC/IN (sin/cos) with DRIVE-CLiQ interface

Supply voltage	24 V
Incremental signals per revolution	
• Resolution	2 ²² bit
• Commutation position (for IC only)	11
• Reference signal	1

Incremental encoder HTL without DRIVE-CLiQ interface

Supply voltage	10 ... 30 V
Incremental signals per revolution	
• Resolution (HTL)	2048/1024
• Reference signal	1

Overview (continued)

Resolver

The number of sine and cosine periods per revolution corresponds to the number of pole pairs of the resolver. In the case of a 2-pole resolver, the evaluation electronics may output an additional zero pulse per encoder revolution. This zero pulse ensures a unique assignment of the position information in relation to an encoder revolution. A 2-pole resolver can therefore be used as a single-turn encoder.

2-pole resolvers can be used for motors with any number of pairs of poles. In the case of multi-pole resolvers, the number of pairs of poles of the motor and resolver are always the same. The resolution is correspondingly higher than with 2-pole resolvers.

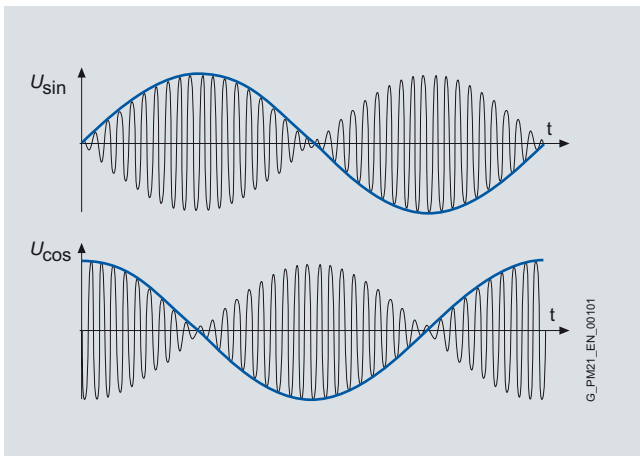

Resolver without DRIVE-CLiQ interface¹⁾

Resolver p = 1 2-pole resolver

Resolver p = 3 6-pole resolver

Resolver p = 4 8-pole resolver

Resolver with DRIVE-CLiQ interface

R15DQ Resolver 15 bit
(resolution 32768, internal, multi-pole)

R14DQ Resolver 14 bit
(resolution 16384, internal, 2-pole)

Technical specifications

Angular error

- Resolver p = 1 and R14DQ ± 840°²⁾
- Resolver p = 3 and R15DQ ± 420°
- Resolver p = 4 and R15DQ ± 240°

Resolver without DRIVE-CLiQ interface

Excitation voltage, rms 2 ... 8 V

Excitation frequency 5 ... 10 kHz

Output signals

$$U_{\text{sine track}} = r \times U_{\text{excitation}} \times \sin \alpha$$

$$U_{\text{cosine track}} = r \times U_{\text{excitation}} \times \cos \alpha$$

$$\alpha = \arctan (U_{\text{sine track}} / U_{\text{cosine track}})$$

Transmission ratio $r = 0.5 \pm 5\%$

Resolver with DRIVE-CLiQ interface

Supply voltage 24 V

- Resolution $2^{15}/2^{14}$ bit

¹⁾ Output signals:
2-pole resolver: 1 sin/cos signal per revolution
6-pole resolver: 3 sin/cos signals per revolution
8-pole resolver: 4 sin/cos signals per revolution

²⁾ For the 1FK701/1FK702 motors: 1200°

Servomotors

Synchronous motors for SINAMICS S120

1FT7 motors

Overview



Motors 1FT7105 forced ventilation, 1FT7082 water cooling and 1FT7042 natural cooling

The 1FT7 motors are permanent-magnet synchronous motors with very compact dimensions and an optically attractive design. Due to the well proven cross-profile and the rotatable connectors with quick-release locks, quick and easy mounting of the motors is possible.

The 1FT7 motors fulfill the highest demands on dynamic performance, speed setting range, shaft and flange accuracy. They are equipped with state-of-the-art encoder technology and optimized for operation on our fully digital drive and control systems.

Natural cooling, forced ventilation or water cooling are available as cooling types. With the natural cooling method, heat is dissipated through the surface of the motor, whereas with the forced ventilation method, heat is forced out by means of built-on fans. Maximum cooling, and thus maximum power ratings can be achieved using water cooling.

Benefits

- Excellent dynamic performance in a wide speed range thanks to high overload capability $\geq 4 \times M_0$ with natural cooling
- High degree of protection – allows operation even with demanding ambient conditions
- High robustness against vibratory and shock loads thanks to vibration-isolated encoder mounting
- Quick and easy mounting due to cross-profile and rotatable connectors with quick-release locks
- Extremely high efficiency
- Due to their low torque ripple, 1FT7 Compact motors are especially suited for use in machine tools that require maximum surface quality and optimum machining quality. Their compact dimensions permit mounting in confined spaces
- 1FT7 High Dynamic motors have very low rotor moments of inertia to achieve extremely good dynamic performance and very short cycle times. As 1FT7 High Dynamic motors are available with forced ventilation and with water cooling, they possess high continuous performance capabilities.

Application

- High-performance machine tools
- Machines with stringent requirements in terms of dynamic performance and precision, e.g.:
 - Packaging machines
 - Foil extractor machines
 - Printing machines
 - Handling equipment

Technical specifications

1FT7 Compact/1FT7 High Dynamic motor	
Type of motor	Permanent-magnet synchronous motor
Magnet material	Rare-earth magnet material
Cooling	Natural cooling, forced ventilation, water cooling
Temperature monitoring	KTY84 temperature sensor in the stator winding
Insulation of the stator winding in accordance with EN 60034-1 (IEC 60034-1)	Temperature class 155 (F) for a winding temperature rise of $\Delta T = 100$ K at an ambient temperature of 40 °C (104 °F). For water cooling, max. inlet temperature 30 °C (86 °F). Avoid condensation.
Type of construction in accordance with EN 60034-7 (IEC 60034-7)	IM B5 (IM V1, IM V3) with flange 0/flange 1 (compatible with 1FT6)
Degree of protection in accordance with EN 60034-5 (IEC 60034-5)	IP64/IP65/IP67
Shaft extension on the drive end (DE) in accordance with DIN 748-3 (IEC 60072-1)	Plain shaft/fitted key and keyway (half-key balancing)
Shaft and flange accuracy in accordance with DIN 42955 (IEC 60072-1) ¹⁾	Tolerance N/Tolerance R
Vibration magnitude in accordance with EN 60034-14 (IEC 60034-14)	Grade A is maintained up to rated speed/Grade R
Sound pressure level L_{pA} (1 m) in accordance with EN ISO 1680, max. Tolerance + 3 dB	60 dB 65 dB 70 dB
Connection	Connectors for signals and power rotatable
Paint finish	Pearl dark grey RAL 9023
2nd rating plate	Enclosed separately
Holding brake	Without/with
Approvals, according to	cURus

Built-in encoder systems without DRIVE-CLiQ interface

Incremental encoder	
IC2048S/R encoder	Incremental encoder sin/cos 1 V _{pp} 2048 S/R with C and D tracks
Absolute encoder	
AM2048S/R encoder	Absolute encoder 2048 S/R, 4096 revolutions, multi-turn

Built-in encoder systems with DRIVE-CLiQ interface

Incremental encoder	
IC22DQ encoder	Incremental encoder 22 bit (resolution 4194304, internal 2048 S/R) + commutation position 11 bit
Absolute encoder	
AM22DQ encoder	Absolute encoder 22 bit (resolution 4194304, internal 2048 S/R) + 12 bit multi-turn (traversing range 4096 revolutions)

S/R=signals/revolution

Options

Order code	Description
X01	Paint finish: Jet black, matt RAL 9005
X02	Paint finish: Cream white RAL 9001
X03	Paint finish: Reseda green RAL 6011
X04	Paint finish: Pebble gray RAL 7032
X05	Paint finish: Sky blue RAL 5015
X06	Paint finish: Light ivory RAL 1015
X09	Paint finish: Anthracite RAL 7016
K23	Special paint finish for "worldwide" climate group: Primer and paint finish in anthracite RAL 7016
K23+X..	Special paint finish for "worldwide" climate group: Primer and paint finish selectable from X01 to X09
K24	Primed (unpainted)
Q12	Sealing air connection (Only in conjunction with IP67 degree of protection. Not in combination with terminal box.)
J..	Mounting of SP+ planetary gearbox (see geared servomotors)

When ordering a motor with options, **-Z** should be added to the order number.

Characteristic curve

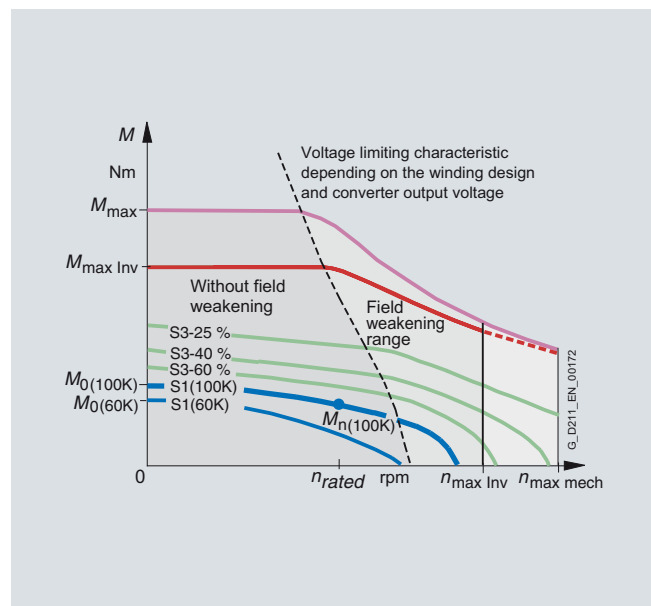

Torque characteristic of a synchronous motor operating on a converter with field weakening (example)

¹⁾ Shaft extension run-out, concentricity of centering ring and shaft, and perpendicularity of flange to shaft.

Servomotors

Synchronous motors for SINAMICS S120

1FT7 Compact core type motors Natural cooling

Selection and ordering data

Rated speed	Shaft height	Rated power	Static torque	Rated torque	Rated current	1FT7 Compact synchronous motors Core type	Number of pole pairs	Moment of inertia of rotor (without brake)	Weight (without brake)
n_{rated}	SH	P_{rated} at $\Delta T=100\text{ K}$	M_0 at $\Delta T=100\text{ K}$	M_{rated} at $\Delta T=100\text{ K}$	I_{rated} at $\Delta T=100\text{ K}$	Order No.	p	J	m
rpm		kW (HP)	Nm (lb _f -ft)	Nm (lb _f -ft)	A			10^{-4} kgm^2 ($10^{-3}\text{ lb}_f\text{-in-s}^2$)	kg (lb)
Natural cooling									
2000	100	5.03 (6.75)	30 (22.1)	24 (17.7)	10	1FT7102-1AC7-1 ■ ■ ■ 1	5	91.4 (80.9)	26.1 (57.6)
		7.96 (10.7)	50 (36.9)	38 (28)	15	1FT7105-1AC7-1 ■ ■ ■ 1	5	178 (158)	44.2 (97.5)
3000	48	1.35 (1.81)	5 (3.7)	4.3 (3.2)	2.6	1FT7044-1AF7-1 ■ ■ ■ 1	3	5.43 (4.81)	7.2 (15.9)
		1.7 (2.28)	6 (4.4)	5.4 (4.0)	3.9	1FT7062-1AF7-1 ■ ■ ■ 1	5	7.36 (6.51)	7.1 (15.7)
	63	2.39 (3.20)	9 (6.6)	7.6 (5.6)	5.2	1FT7064-1AF7-1 ■ ■ ■ 1	5	11.9 (10.5)	9.7 (21.4)
		3.24 (4.34)	13 (9.6)	10.3 (7.6)	6.6	1FT7082-1AF7-1 ■ ■ ■ 1	5	26.5 (23.5)	14.0 (30.9)
		4.56 (6.11)	20 (14.8)	14.5 (10.7)	8.5	1FT7084-1AF7-1 ■ ■ ■ 1	5	45.1 (39.9)	20.8 (45.9)
		5.65 (7.58)	28 (20.7)	18 (13.3)	11	1FT7086-1AF7-1 ■ ■ ■ 1	5	63.6 (56.3)	27.5 (60.6)
4500	80	4.82 (6.46) ¹⁾	20 (14.8)	11.5 (8.5) ¹⁾	10.1 ¹⁾	1FT7084-1AH7-1 ■ ■ ■ 1	5	45.1 (39.9)	20.8 (45.9)
		4.71 (6.32)	28 (20.7)	10 (7.4)	10	1FT7086-1AH7-1 ■ ■ ■ 1	5	63.6 (56.3)	27.5 (60.6)
6000	36	0.88 (1.18)	2 (1.5)	1.4 (1.0)	2.1	1FT7034-1AK7-1 ■ ■ ■ 1	3	0.85 (0.75)	3.8 (8.38)
		2.13 (2.86) ²⁾	6 (4.4)	3.7 (2.7) ²⁾	5.9 ²⁾	1FT7062-1AK7-1 ■ ■ ■ 1	5	7.36 (6.51)	7.1 (15.7)
	63	2.59 (3.47) ³⁾	9 (6.6)	5.5 (4.1) ³⁾	6.1 ³⁾	1FT7064-1AK7-1 ■ ■ ■ 1	5	11.9 (10.5)	9.7 (21.4)
Type of construction:			IM B5	Flange 0	0	1	N	M	D
				Flange 1 (compatible with 1FT6)	1				
Encoder systems for motors without DRIVE-CLiQ interface:			IC2048S/R encoder						
			AM2048S/R encoder						
Encoder systems for motors with DRIVE-CLiQ interface:			IC22DQ encoder						
			AM22DQ encoder						
Shaft extension:			Shaft and flange accuracy:		Holding brake:		G	H	1
Plain shaft			Tolerance N		Without				
Plain shaft			Tolerance N		With				
Vibration magnitude:			Degree of protection:						
Grade A			IP65						

To select the type of construction and degree of protection, see Technical definitions.

Some 1FT7 Compact motors are available as core types. These core types can be express delivered as replacement motors in the event of plant outages and offer the advantage of a quicker spare parts supply. For this reason, core types should be used for configuration wherever possible.

Servomotors

Synchronous motors for SINAMICS S120

1FT7 Compact core type motors
Natural cooling

Motor type (repeated)	Efficiency ⁴⁾ η %	Static current I_0 at M_0 $\Delta T=100$ K A	Calculated power P_{calc} ⁷⁾ P_{calc} for M_0 $\Delta T=100$ K kW (HP)	SINAMICS S120 Motor Module		Power cable with complete shield		
				Rated output current ⁵⁾ I_{rated} A	Booksized format For additional versions and components, see chapter SINAMICS S120 drive system Order No.	Motor connection (and brake connection) via power connector		
				Power connector Size	Cable cross- section ⁶⁾ mm ²	Pre-assembled cable Order No.		
1FT7102-1AC7...	93	12.5	6.28 (8.42)	18	6SL312-TE21-8AA3	1.5	4 × 1.5	6FX002-5N21-....
1FT7105-1AC7...	93	18	10.47 (14.0)	18	6SL312-TE21-8AA3	1.5	4 × 2.5	6FX002-5N31-....
1FT7044-1AF7...	92	2.8	1.57 (2.11)	3	6SL312-TE13-0AA3	1	4 × 1.5	6FX002-5N01-....
1FT7062-1AF7...	91	3.9	1.88 (2.52)	5	6SL312-TE15-0AA3	1	4 × 1.5	6FX002-5N01-....
1FT7064-1AF7...	93	5.7	2.83 (3.80)	9	6SL312-TE21-0AA3	1	4 × 1.5	6FX002-5N01-....
1FT7082-1AF7...	93	7.6	4.08 (5.47)	9	6SL312-TE21-0AA3	1	4 × 1.5	6FX002-5N01-....
1FT7084-1AF7...	93	11	6.28 (8.42)	18	6SL312-TE21-8AA3	1	4 × 1.5	6FX002-5N01-....
1FT7086-1AF7...	93	15.5	8.80 (11.8)	18	6SL312-TE21-8AA3	1.5	4 × 2.5	6FX002-5N31-....
1FT7084-1AH7...	93	15.6	9.42 (12.6)	18	6SL312-TE21-8AA3	1.5	4 × 2.5	6FX002-5N31-....
1FT7086-1AH7...	91	22.4	13.19 (17.7)	30	6SL312-1TE23-0AA3	1.5	4 × 4	6FX002-5N41-....
1FT7034-1AK7...	90	2.7	1.26 (1.69)	3	6SL312-TE13-0AA3	1	4 × 1.5	6FX002-5N01-....
1FT7062-1AK7...	90	8.4	3.77 (5.06)	9	6SL312-TE21-0AA3	1	4 × 1.5	6FX002-5N01-....
1FT7064-1AK7...	91	9	5.65 (7.58)	9	6SL312-TE21-0AA3	1	4 × 1.5	6FX002-5N01-....

Cooling:	
Internal air cooling	0
External air cooling	1
Motor Module:	
Single Motor Module	1
Double Motor Module	2

Power cable:	
MOTION-CONNECT 800	8
MOTION-CONNECT 500	5
Without brake cores	C
With brake cores	D
Length code

Information about the cables
can be found in chapter
Connection system MOTION-CONNECT.

¹⁾ These values refer to $n = 4000$ rpm.

²⁾ These values refer to $n = 5500$ rpm.

³⁾ These values refer to $n = 4500$ rpm.

⁴⁾ Optimum efficiency in continuous duty.

⁵⁾ With default setting of the pulse frequency.

⁶⁾ The current carrying capacity of the power cables complies with EN 60204-1 for installation type C, for continuous duty at an ambient air temperature of 40 °C (104 °F).

⁷⁾

$$P_{calc} [kW] = \frac{M_0 [Nm] \times n_{rated}}{9550} \quad P_{calc} [HP] = \frac{M_0 [lb-ft] \times n_{rated}}{5250}$$

Servomotors

Synchronous motors for SINAMICS S120

1FT7 Compact motors Natural cooling

Selection and ordering data

Rated speed	Shaft height	Rated power	Static torque	Rated torque	Rated current	1FT7 Compact synchronous motors	Number of pole pairs	Moment of inertia of rotor (without brake)	Weight (without brake)
n_{rated}	SH	P_{rated} at $\Delta T=100\text{ K}$	M_0 at $\Delta T=100\text{ K}$	M_{rated} at $\Delta T=100\text{ K}$	I_{rated} at $\Delta T=100\text{ K}$	Order No.	p	J	m
rpm		kW (HP)	Nm (lb _f -ft)	Nm (lb _f -ft)	A			10^{-4} kgm^2 ($10^{-3}\text{ lb}_f\text{-in-s}^2$)	kg (lb)
Natural cooling									
1500	100	4.08 (5.47)	30 (22.1)	26 (19.2)	8	1FT7102-5AB7 ■-1 ■ ■ ■	5	91.4 (80.9)	26.1 (57.5)
		6.60 (8.85)	50 (36.9)	42 (31.0)	13	1FT7105-5AB7 ■-1 ■ ■ ■	5	178 (157)	44.2 (97.5)
		9.58 (12.8)	70 (51.6)	61 (45.0)	16	1FT7108-5AB7 ■-1 ■ ■ ■	5	248 (219)	59 (130)
2000	80	2.39 (3.20)	13 (9.6)	11.4 (8.4)	4.9	1FT7082-5AC7 ■-1 ■ ■ ■	5	26.5 (23.5)	14 (30.9)
		3.54 (4.75)	20 (14.8)	16.9 (12.5)	8.4	1FT7084-5AC7 ■-1 ■ ■ ■	5	45.1 (39.9)	20.8 (45.9)
		4.71 (6.32)	28 (20.7)	22.5 (16.6)	9.2	1FT7086-5AC7 ■-1 ■ ■ ■	5	63.6 (56.3)	27.5 (60.6)
	100	5.03 (6.75)	30 (22.1)	24 (17.7)	10	1FT7102-5AC7 ■-1 ■ ■ ■	5	91.4 (80.9)	26.1 (57.5)
		7.96 (10.7)	50 (36.9)	38 (28.0)	15	1FT7105-5AC7 ■-1 ■ ■ ■	5	178 (157)	44.2 (97.5)
		10.5 (14.1)	70 (51.6)	50 (36.9)	18	1FT7108-5AC7 ■-1 ■ ■ ■	5	248 (219)	59 (130)
3000	48	0.85 (1.14)	3 (2.2)	2.7 (2.0)	2.1	1FT7042-5AF7 ■-1 ■ ■ ■	3	2.81 (2.49)	4.6 (10.1)
		1.35 (1.81)	5 (3.7)	4.3 (3.2)	2.6	1FT7044-5AF7 ■-1 ■ ■ ■	3	5.43 (4.81)	7.2 (15.9)
		1.76 (2.36)	7 (5.2)	5.6 (4.1)	3.5	1FT7046-5AF7 ■-1 ■ ■ ■	3	7.52 (6.66)	9.3 (20.5)
	63	1.70 (2.28)	6 (4.4)	5.4 (4.0)	3.9	1FT7062-5AF7 ■-1 ■ ■ ■	5	7.36 (6.51)	7.1 (15.7)
		2.39 (3.20)	9 (6.6)	7.6 (5.6)	5.2	1FT7064-5AF7 ■-1 ■ ■ ■	5	11.9 (10.5)	9.7 (21.4)
		2.92 (3.92)	12 (8.9)	9.3 (6.9)	7.2	1FT7066-5AF7 ■-1 ■ ■ ■	5	16.4 (14.5)	12.3 (27.1)
		3.42 (4.59)	15 (11.1)	10.9 (8.0)	6.7	1FT7068-5AF7 ■-1 ■ ■ ■	5	23.2 (20.5)	16.3 (35.9)
	80	3.24 (4.34)	13 (9.6)	10.3 (7.6)	6.6	1FT7082-5AF7 ■-1 ■ ■ ■	5	26.5 (23.5)	14 (30.9)
		4.55 (6.10)	20 (14.8)	14.5 (10.7)	8.5	1FT7084-5AF7 ■-1 ■ ■ ■	5	45.1 (39.9)	20.8 (45.9)
		5.65 (7.58)	28 (20.7)	18 (13.3)	11	1FT7086-5AF7 ■-1 ■ ■ ■	5	63.6 (56.3)	27.5 (60.6)
	100	6.28 (8.42)	30 (22.1)	20 (14.8)	12	1FT7102-5AF7 ■-1 ■ ■ ■	5	91.4 (80.9)	26.1 (57.5)
		8.80 (11.8)	50 (36.9)	28 (20.7)	15	1FT7105-5AF7 ■-1 ■ ■ ■	5	178 (157)	44.2 (97.5)
6.28 (8.42)		70 (51.6)	20 (14.8)	12	1FT7108-5AF7 ■-1 ■ ■ ■	5	248 (220)	59 (130)	

Type of construction:	IM B5	Flange 0	0
		Flange 1 (compatible with 1FT6)	1
Encoder systems for motors without DRIVE-CLiQ interface:	IC2048S/R encoder		N
	AM2048S/R encoder		M
Encoder systems for motors with DRIVE-CLiQ interface:	IC22DQ encoder		D
	AM22DQ encoder		F
Shaft extension:	Shaft and flange accuracy:	Holding brake:	
Fitted key and keyway	Tolerance N	Without	A
Fitted key and keyway	Tolerance N	With	B
Fitted key and keyway	Tolerance R	Without	D
Fitted key and keyway	Tolerance R	With	E
Plain shaft	Tolerance N	Without	G
Plain shaft	Tolerance N	With	H
Plain shaft	Tolerance R	Without	K
Plain shaft	Tolerance R	With	L
Vibration magnitude:	Degree of protection:		
Grade A	IP64		0
Grade A	IP65		1
Grade A	IP67		2
Grade R	IP64		3
Grade R	IP65		4
Grade R	IP67		5

To select the type of construction and degree of protection, see Technical definitions.

Motor type (repeated)	Efficiency ¹⁾ η %	Static current I_0 at M_0 $\Delta T=100$ K A	Calculated power P_{calc} ⁴⁾ P_{calc} for M_0 $\Delta T=100$ K kW (HP)	SINAMICS S120 Motor Module		Power cable with complete shield		
				Rated output current ²⁾ I_{rated} A	Booksized format For additional versions and components, see chapter SINAMICS S120 drive system Order No.	Motor connection (and brake connection) via power connector		
						Power connector Size	Cable cross- section ³⁾ mm ²	Pre-assembled cable Order No.
1FT7102-5AB7...	93	9	4.71 (6.32)	9	6SL312-TE21-0AA3	1.5	4 × 1.5	6FX002-5N21-....
1FT7105-5AB7...	93	15	7.85 (10.5)	18	6SL312-TE21-8AA3	1.5	4 × 1.5	6FX002-5N21-....
1FT7108-5AB7...	93	18	10.99 (14.7)	18	6SL312-TE21-8AA3	1.5	4 × 2.5	6FX002-5N31-....
1FT7082-5AC7...	93	5	2.72 (3.65)	5	6SL312-TE15-0AA3	1	4 × 1.5	6FX002-5N01-....
1FT7084-5AC7...	93	9	4.19 (5.62)	9	6SL312-TE21-0AA3	1	4 × 1.5	6FX002-5N01-....
1FT7086-5AC7...	93	10.6	5.86 (7.86)	18	6SL312-TE21-8AA3	1	4 × 1.5	6FX002-5N01-....
1FT7102-5AC7...	93	12.5	6.28 (8.42)	18	6SL312-TE21-8AA3	1.5	4 × 1.5	6FX002-5N21-....
1FT7105-5AC7...	93	18	10.47 (14.0)	18	6SL312-TE21-8AA3	1.5	4 × 2.5	6FX002-5N31-....
1FT7108-5AC7...	93	25	14.66 (19.7)	30	6SL312-1TE23-0AA3	1.5	4 × 4	6FX002-5N41-....
1FT7042-5AF7...	92	2.1	0.94 (1.26)	3	6SL312-TE13-0AA3	1	4 × 1.5	6FX002-5N01-....
1FT7044-5AF7...	92	2.8	1.57 (2.11)	3	6SL312-TE13-0AA3	1	4 × 1.5	6FX002-5N01-....
1FT7046-5AF7...	92	4	2.20 (2.95)	5	6SL312-TE15-0AA3	1	4 × 1.5	6FX002-5N01-....
1FT7062-5AF7...	91	3.9	1.88 (2.52)	5	6SL312-TE15-0AA3	1	4 × 1.5	6FX002-5N01-....
1FT7064-5AF7...	93	5.7	2.83 (3.80)	9	6SL312-TE21-0AA3	1	4 × 1.5	6FX002-5N01-....
1FT7066-5AF7...	92	8.4	3.77 (5.06)	9	6SL312-TE21-0AA3	1	4 × 1.5	6FX002-5N01-....
1FT7068-5AF7...	92	8.3	4.71 (6.32)	9	6SL312-TE21-0AA3	1	4 × 1.5	6FX002-5N01-....
1FT7082-5AF7...	93	7.6	4.08 (5.47)	9	6SL312-TE21-0AA3	1	4 × 1.5	6FX002-5N01-....
1FT7084-5AF7...	93	11	6.28 (8.42)	18	6SL312-TE21-8AA3	1	4 × 1.5	6FX002-5N01-....
1FT7086-5AF7...	93	15.5	8.80 (11.8)	18	6SL312-TE21-8AA3	1.5	4 × 2.5	6FX002-5N31-....
1FT7102-5AF7...	93	18	9.42 (12.6)	18	6SL312-TE21-8AA3	1.5	4 × 2.5	6FX002-5N31-....
1FT7105-5AF7...	94	26	15.71 (21.1)	30	6SL312-1TE23-0AA3	1.5	4 × 4	6FX002-5N41-....
1FT7108-5AF7...	93	36	21.99 (29.5)	45	6SL312-1TE24-5AA3	1.5	4 × 6	6FX002-5N54-....

Cooling:	
Internal air cooling	0
External air cooling	1
Motor Module:	
Single Motor Module	1
Double Motor Module	2

Power cable:	
MOTION-CONNECT 800	8
MOTION-CONNECT 500	5
Without brake cores	C
With brake cores	D
Length code

Information about the cables
can be found in chapter
Connection system MOTION-CONNECT.

1) Optimum efficiency in continuous duty.

2) With default setting of the pulse frequency.

3) The current carrying capacity of the power cables complies with EN 60204-1 for installation type C, for continuous duty at an ambient air temperature of 40 °C (104 °F).

4) $P_{calc} [kW] = \frac{M_0 [Nm] \times n_{rated}}{9550}$ $P_{calc} [HP] = \frac{M_0 [lb-ft] \times n_{rated}}{5250}$

Servomotors

Synchronous motors for SINAMICS S120

1FT7 Compact motors Natural cooling

Selection and ordering data

Rated speed	Shaft height	Rated power	Static torque	Rated torque	Rated current	1FT7 Compact synchronous motors	Number of pole pairs	Moment of inertia of rotor (without brake)	Weight (without brake)
n_{rated}	SH	P_{rated} at $\Delta T=100\text{ K}$	M_0 at $\Delta T=100\text{ K}$	M_{rated} at $\Delta T=100\text{ K}$	I_{rated} at $\Delta T=100\text{ K}$	Order No.	p	J	m
rpm		kW (HP)	Nm (lb _f -ft)	Nm (lb _f -ft)	A			10^{-4} kgm^2 ($10^{-3}\text{ lb}_f\text{-in-s}^2$)	kg (lb)
Natural cooling									
4500	48	1.32 (1.77) ¹⁾	7 (5.2)	3.6 (2.7) ¹⁾	4.7 ¹⁾	1FT7046-5AH7-1 ■ ■ ■ ■	3	7.52 (6.66)	9.3 (20.5)
	63	2.55 (3.42) ²⁾	12 (8.9)	6.1 (4.5) ²⁾	7.5 ²⁾	1FT7066-5AH7-1 ■ ■ ■ ■	5	16.4 (14.5)	12.3 (27.1)
	80	3.77 (5.06)	13 (9.6)	8 (5.9)	7.8	1FT7082-5AH7-1 ■ ■ ■ ■	5	26.5 (23.5)	14 (30.9)
		4.82 (6.46) ²⁾	20 (14.8)	11.5 (8.5) ²⁾	10.1 ²⁾	1FT7084-5AH7-1 ■ ■ ■ ■	5	45.1 (39.9)	20.8 (45.9)
		4.71 (6.32)	28 (20.7)	10 (7.4)	10	1FT7086-5AH7-1 ■ ■ ■ ■	5	63.6 (56.3)	27.5 (60.6)
6000	36	0.88 (1.18)	2 (1.5)	1.4 (1.0)	2.1	1FT7034-5AK7-1 ■ ■ ■ ■	3	0.85 (0.75)	3.8 (8.38)
		1.07 (1.43)	3 (2.2)	1.7 (1.3)	2.4	1FT7036-5AK7-1 ■ ■ ■ ■	3	1.33 (1.18)	5.0 (11.0)
	48	1.26 (1.69)	3 (2.2)	2 (1.5)	3	1FT7042-5AK7-1 ■ ■ ■ ■	3	2.81 (2.49)	4.6 (10.1)
		1.41 (1.89) ³⁾	5 (3.7)	3 (2.2) ³⁾	3.6 ³⁾	1FT7044-5AK7-1 ■ ■ ■ ■	3	5.43 (4.81)	7.2 (15.9)
	63	2.13 (2.86) ⁴⁾	6 (4.4)	3.7 (2.7) ⁴⁾	5.9 ⁴⁾	1FT7062-5AK7-1 ■ ■ ■ ■	5	7.36 (6.51)	7.1 (15.7)
		2.59 (3.47) ³⁾	9 (6.6)	5.5 (4.1) ³⁾	6.1 ³⁾	1FT7064-5AK7-1 ■ ■ ■ ■	5	11.9 (10.5)	9.7 (21.4)
Type of construction:			IM B5	Flange 0	0				
				Flange 1 (compatible with 1FT6)	1				
Encoder systems for motors without DRIVE-CLiQ interface:			IC2048S/R encoder			N			
			AM2048S/R encoder			M			
Encoder systems for motors with DRIVE-CLiQ interface:			IC22DQ encoder			D			
			AM22DQ encoder			F			
Shaft extension:			Shaft and flange accuracy:			Holding brake:			
Fitted key and keyway			Tolerance N			Without			A
Fitted key and keyway			Tolerance N			With			B
Fitted key and keyway			Tolerance R			Without			D
Fitted key and keyway			Tolerance R			With			E
Plain shaft			Tolerance N			Without			G
Plain shaft			Tolerance N			With			H
Plain shaft			Tolerance R			Without			K
Plain shaft			Tolerance R			With			L
Vibration magnitude:			Degree of protection:						0
Grade A			IP64						1
Grade A			IP65						2
Grade A			IP67						2
Grade R			IP64						3
Grade R			IP65						4
Grade R			IP67						5

To select the type of construction and degree of protection, see Technical definitions.

Servomotors

Synchronous motors for SINAMICS S120

1FT7 Compact motors
Natural cooling

Motor type (repeated)	Efficiency ⁵⁾ η %	Static current I_0 at M_0 $\Delta T=100$ K A	Calculated power P_{calc} ⁸⁾ P_{calc} for M_0 $\Delta T=100$ K kW (HP)	SINAMICS S120 Motor Module		Power cable with complete shield		
				Rated output current ⁶⁾ I_{rated} A	Booksized format For additional versions and components, see chapter SINAMICS S120 drive system Order No.	Motor connection (and brake connection) via power connector		
						Power connector Size	Cable cross-section ⁷⁾ mm ²	Pre-assembled cable Order No.
1FT7046-5AH7...	90	8.1	3.3 (4.43)	9	6SL312-1-TE21-0AA3	1	4 × 1.5	6FX0002-5N01-....
1FT7066-5AH7...	90	13.6	5.65 (7.58)	18	6SL312-1-TE21-8AA3	1	4 × 1.5	6FX0002-5N01-....
1FT7082-5AH7...	93	12.3	6.13 (8.22)	18	6SL312-1-TE21-8AA3	1	4 × 1.5	6FX0002-5N01-....
1FT7084-5AH7...	93	15.6	9.42 (12.6)	18	6SL312-1-TE21-8AA3	1.5	4 × 2.5	6FX0002-5N31-....
1FT7086-5AH7...	91	22.4	13.19 (17.7)	30	6SL312-1-TE23-0AA3	1.5	4 × 4	6FX0002-5N41-....
1FT7034-5AK7...	90	2.7	1.26 (1.69)	3	6SL312-1-TE13-0AA3	1	4 × 1.5	6FX0002-5N01-....
1FT7036-5AK7...	90	4.0	1.88 (2.52)	5	6SL312-1-TE15-0AA3	1	4 × 1.5	6FX0002-5N01-....
1FT7042-5AK7...	91	3.9	1.88 (2.52)	5	6SL312-1-TE15-0AA3	1	4 × 1.5	6FX0002-5N01-....
1FT7044-5AK7...	91	5.7	3.14 (4.21)	9	6SL312-1-TE21-0AA3	1	4 × 1.5	6FX0002-5N01-....
1FT7062-5AK7...	90	8.4	3.77 (5.06)	9	6SL312-1-TE21-0AA3	1	4 × 1.5	6FX0002-5N01-....
1FT7064-5AK7...	91	9	5.65 (7.58)	9	6SL312-1-TE21-0AA3	1	4 × 1.5	6FX0002-5N01-....

Cooling:	
Internal air cooling	0
External air cooling	1
Motor Module:	
Single Motor Module	1
Double Motor Module	2

Power cable:	
MOTION-CONNECT 800	8
MOTION-CONNECT 500	5
Without brake cores	C
With brake cores	D
Length code

Information about the cables
can be found in chapter
Connection system MOTION-CONNECT.

1) These values refer to $n = 3500$ rpm.

2) These values refer to $n = 4000$ rpm.

3) These values refer to $n = 4500$ rpm.

4) These values refer to $n = 5500$ rpm.

5) Optimum efficiency in continuous duty.

6) With default setting of the pulse frequency.

7) The current carrying capacity of the power cables complies with EN 60204-1 for installation type C, for continuous duty at an ambient air temperature of 40 °C (104 °F).

8) $P_{calc} [kW] = \frac{M_0 [Nm] \times n_{rated}}{9550}$ $P_{calc} [HP] = \frac{M_0 [lb-ft] \times n_{rated}}{5250}$

Servomotors

Synchronous motors for SINAMICS S120

1FT7 Compact motors Forced ventilation

Selection and ordering data

Rated speed	Shaft height	Rated power	Static torque	Rated torque	Rated current	1FT7 Compact synchronous motors	Number of pole pairs	Moment of inertia of rotor (without brake)	Weight (without brake)
n_{rated}	SH	P_{rated} at $\Delta T=100\text{ K}$	M_0 at $\Delta T=100\text{ K}$	M_{rated} at $\Delta T=100\text{ K}$	I_{rated} at $\Delta T=100\text{ K}$	Order No.	p	J	m
rpm		kW (HP)	Nm (lb _f -ft)	Nm (lb _f -ft)	A			10^{-4} kgm^2 ($10^{-3}\text{ lb}_f\text{-in-s}^2$)	kg (lb)
Forced ventilation									
2000	80	5.0 (6.7)	27 (19.9)	24 (17.7)	13.5	1FT7084-5SC7-1 ■ ■ ■ ■	5	45 (39.8)	25 (55.1)
		6.7 (8.98)	36 (26.5)	32 (23.6)	17	1FT7086-5SC7-1 ■ ■ ■ ■	5	64 (56.7)	36 (79.4)
	100	11.7 (15.7)	65 (47.9)	56 (41.3)	29	1FT7105-5SC7-1 ■ ■ ■ ■	5	178 (157.6)	50 (110.3)
		15.3 (20.5)	91 (67.1)	73 (53.8)	33	1FT7108-5SC7-1 ■ ■ ■ ■	5	248 (219.5)	64 (141.1)
3000	80	7.2 (9.66)	27 (19.9)	23 (17)	18.5	1FT7084-5SF7-1 ■ ■ ■ ■	5	45 (39.8)	25 (55.1)
		9.1 (12.2)	36 (26.5)	29 (21.4)	24	1FT7086-5SF7-1 ■ ■ ■ ■	5	64 (56.7)	36 (79.4)
	100	15.1 (20.3)	65 (47.9)	48 (35.4)	35	1FT7105-5SF7-1 ■ ■ ■ ■	5	178 (157.6)	50 (110.3)
		18.8 (25.1)	91 (67.1)	60 (44.3)	38	1FT7108-5SF7-1 ■ ■ ■ ■	5	248 (219.5)	64 (141.1)
4500	80	9.9 (13.3)	27 (19.9)	21 (15.5)	24.5	1FT7084-5SH7-1 ■ ■ ■ ■	5	45 (39.8)	25 (55.1)
		11.8 (15.8)	36 (26.5)	25 (18.4)	25	1FT7086-5SH7-1 ■ ■ ■ ■	5	64 (56.7)	36 (79.4)
Type of construction:			IM B5	Flange 0 Flange 1 (compatible with 1FT6)	0 1				
Connector outlet direction:			Connector size 1 and 1.5 Connector size 3 ¹⁾	Rotatable connector Transverse right Transverse left Axial NDE Axial DE	1 1 2 3 4				
Terminal box/ cable entry:¹⁾			Top/transverse from right Top/transverse from left Top/axial from NDE Top/axial from DE		5 6 7 8				
Encoder systems for motors without DRIVE-CLiQ interface:			IC2048S/R encoder AM2048S/R encoder		N M				
Shaft extension:		Shaft and flange accuracy:		Holding brake:					
Fitted key		Tolerance N		Without					A
Fitted key		Tolerance N		With					B
Fitted key		Tolerance R		Without					D
Fitted key		Tolerance R		With					E
Plain shaft		Tolerance N		Without					G
Plain shaft		Tolerance N		With					H
Plain shaft		Tolerance R		Without					K
Plain shaft		Tolerance R		With					L
Vibration magnitude:			Degree of protection:²⁾						
Grade A			IP64						0
Grade A			IP65						1
Grade R			IP64						3
Grade R			IP65						4

To select the type of construction and degree of protection, see Technical definitions.

Servomotors

Synchronous motors for SINAMICS S120

1FT7 Compact motors
Forced ventilation

Motor type (repeated)	Efficiency ³⁾ η	Static current I_0 at M_0 $\Delta T=100$ K	Calculated power P_{calc} ⁶⁾ P_{calc} for M_0 $\Delta T=100$ K	SINAMICS S120 Motor Module		Power cable with complete shield		
				Rated output current ⁴⁾ I_{rated}	Booksized format For additional versions and components, see chapter SINAMICS S120 drive system Order No.	Motor connection (and brake connection) via power connector		
	%	A	kW (HP)	A		Power connector Size	Cable cross-section ⁵⁾ mm ²	Pre-assembled cable Order No.
1FT7084-5SC7...	93	15	5.7 (7.64)	18	6SL312-1TE21-8AA3	1.5	4 × 1.5	6FX0002-5N21-....
1FT7086-5SC7...	93	19.5	7.5 (10.1)	30	6SL312-1TE23-0AA3	1.5	4 × 2.5	6FX0002-5N31-....
1FT7105-5SC7...	93	31	13.6 (18.2)	45	6SL312-1TE24-5AA3	1.5	4 × 6	6FX0002-5N54-....
1FT7108-5SC7...	93	39	19.1 (25.6)	45	6SL312-1TE24-5AA3	1.5	4 × 10	6FX0002-5N64-....
1FT7084-5SF7...	94	21	8.5 (11.4)	30	6SL312-1TE23-0AA3	1.5	4 × 2.5	6FX0002-5N31-....
1FT7086-5SF7...	93	29	11.3 (15.2)	30	6SL312-1TE23-0AA3	1.5	4 × 6	6FX0002-5N51-....
1FT7105-5SF7...	94	45	20.4 (27.4)	45	6SL312-1TE24-5AA3	3	4 × 10	6FX0002-5S14-....
1FT7108-5SF7...	94	57	28.6 (38.4)	60	6SL312-1TE26-0AA3	3	4 × 16	6FX0002-5S23-....
1FT7084-5SH7...	94	30.5	12.7 (17.0)	30	6SL312-1TE23-0AA3	1.5	4 × 6	6FX0002-5N51-....
1FT7086-5SH7...	93	34	17.0 (22.8)	45	6SL312-1TE24-5AA3	1.5	4 × 6	6FX0002-5N54-....

Cooling:	
Internal air cooling	0
External air cooling	1
Motor Module:	
Single Motor Module	1
Double Motor Module	2

Power cable:	
MOTION-CONNECT 800	8
MOTION-CONNECT 500	5
Without brake cores	C
With brake cores	D
Length code

Information about the cables can be found in chapter Connection system MOTION-CONNECT.

1) Connector size 3 not rotatable. An alternative terminal box can be selected with connector size 3 only.

2) The degree of protection refers to the motor. The built-in fan meets the requirements of degree of protection IP54.

3) Optimum efficiency in continuous duty.

4) With default setting of the pulse frequency.

5) The current carrying capacity of the power cable complies with EN 60204-1 for installation type C, for continuous duty at an ambient air temperature of 40 °C (104 °F).

6) $P_{calc} [kW] = \frac{M_0 [Nm] \times n_{rated}}{9550}$ $P_{calc} [HP] = \frac{M_0 [lb_f-ft] \times n_{rated}}{5250}$

Servomotors

Synchronous motors for SINAMICS S120

1FT7 Compact motors Water cooling

Selection and ordering data

Rated speed	Shaft height	Rated power	Static torque	Rated torque	Rated current	1FT7 Compact synchronous motors	Number of pole pairs	Moment of inertia of rotor (without brake)	Weight (without brake)
n_{rated}	SH	$P_{\text{rated at } \Delta T=100 \text{ K}}$	$M_0 \text{ at } \Delta T=100 \text{ K}$	$M_{\text{rated at } \Delta T=100 \text{ K}}$	$I_{\text{rated at } \Delta T=100 \text{ K}}$	Order No.	p	J	m
rpm		kW (HP)	Nm (lb _f -ft)	Nm (lb _f -ft)	A			10 ⁻⁴ kgm ² (10 ⁻³ lb _f -in-s ²)	kg (lb)
Water cooling									
1500	100	7.9 (10.6)	50 (36.9)	50 (36.9)	20.3	1FT7102-5WB7-1 ■■■	5	98.9 (87.5)	36.6 (80.7)
		14.1 (18.9)	90 (66.3)	90 (66.3)	29.5	1FT7105-5WB7-1 ■■■	5	191 (169)	54.8 (121)
		19.6 (26.3)	125 (92.1)	125 (92.1)	40.3	1FT7108-5WB7-1 ■■■	5	265 (235)	68.6 (151)
2000	80	4.4 (5.90)	21 (15.5)	21 (15.5)	11	1FT7082-5WC7-1 ■■■	5	28.9 (25.6)	20.7 (45.6)
		7.33 (9.83)	35 (25.8)	35 (25.8)	17	1FT7084-5WC7-1 ■■■	5	48.3 (42.8)	27.5 (60.6)
		10.5 (14.1)	50 (36.9)	50 (36.9)	24	1FT7086-5WC7-1 ■■■	5	67.8 (60.0)	34.1 (75.2)
	100	10.4 (14.0)	50 (36.9)	49.5 (36.5)	29.3	1FT7102-5WC7-1 ■■■	5	98.9 (87.5)	36.6 (80.7)
		18.8 (25.2)	90 (66.3)	90 (66.3)	40.8	1FT7105-5WC7-1 ■■■	5	191 (169)	54.8 (121)
		26.2 (35.1)	125 (92.1)	125 (92.1)	47.5	1FT7108-5WC7-1 ■■■	5	265 (235)	69.6 (153)
Type of construction:		IM B5	Flange 0	Flange 1 (compatible with 1FT6)	0				
Connector outlet direction:		Connector size 1 and 1.5	Rotatable connector		1				
		Connector size 3 ¹⁾	Transverse right		1				
			Transverse left		2				
			Axial NDE		3				
			Axial DE		4				
Terminal box/cable entry:¹⁾		Top/transverse from right			5				
		Top/transverse from left			6				
		Top/axial from NDE			7				
		Top/axial from DE			8				
Encoder systems for motors without DRIVE-CLiQ interface:		IC2048S/R encoder				N			
		AM2048S/R encoder				M			
Encoder systems for motors with DRIVE-CLiQ interface:		IC22DQ encoder				D			
		AM22DQ encoder				F			
Shaft extension:		Fitted key and keyway	Tolerance N	Without		A			
		Fitted key and keyway	Tolerance N	With		B			
		Fitted key and keyway	Tolerance R	Without		D			
		Fitted key and keyway	Tolerance R	With		E			
		Plain shaft	Tolerance N	Without		G			
		Plain shaft	Tolerance N	With		H			
		Plain shaft	Tolerance R	Without		K			
		Plain shaft	Tolerance R	With		L			
Vibration magnitude:		Grade A	IP64			0			
		Grade A	IP65			1			
		Grade A	IP67			2			
		Grade R	IP64			3			
		Grade R	IP65			4			
		Grade R	IP67			5			

To select the type of construction and degree of protection, see Technical definitions.

Motor type (repeated)	Efficiency ²⁾ η %	Static current I_0 at M_0 $\Delta T=100$ K A	Calculated power P_{calc} ³⁾ for M_0 $\Delta T=100$ K kW (HP)	SINAMICS S120 Motor Module		Power cable with complete shield		
				Rated output current ³⁾ I_{rated} A	Booksized format For additional versions and components, see chapter SINAMICS S120 drive system Order No.	Motor connection (and brake connection) via power connector		
						Power connector Size	Cable cross- section ⁴⁾ mm ²	Pre-assembled cable Order No.
1FT7102-5WB7...	93	17.8	7.9 (10.6)	18	6SL312-TE21-8AA3	1.5	4 × 2.5	6FX002-5N31-....
1FT7105-5WB7...	94	28	14.1 (18.9)	30	6SL312-1TE23-0AA3	1.5	4 × 4	6FX002-5N41-....
1FT7108-5WB7...	94	39	19.6 (26.3)	45	6SL312-1TE24-5AA3	1.5	4 × 10	6FX002-5N64-....
1FT7082-5WC7...	93	10.7	4.4 (5.90)	18	6SL312-TE21-8AA3	1.5	4 × 1.5	6FX002-5N21-....
1FT7084-5WC7...	94	16.5	7.3 (9.79)	18	6SL312-TE21-8AA3	1.5	4 × 2.5	6FX002-5N31-....
1FT7086-5WC7...	94	23	10.5 (14.1)	30	6SL312-1TE23-0AA3	1.5	4 × 4	6FX002-5N41-....
1FT7102-5WC7...	94	25.5	10.5 (14.1)	30	6SL312-1TE23-0AA3	1.5	4 × 4	6FX002-5N41-....
1FT7105-5WC7...	94	39	18.8 (25.2)	45	6SL312-1TE24-5AA3	1.5	4 × 10	6FX002-5N64-....
1FT7108-5WC7...	95	45.3	26.2 (35.1)	45	6SL312-1TE24-5AA3	3	4 × 10	6FX002-5S14-....

Cooling:	
Internal air cooling	0
External air cooling	1
Motor Module:	
Single Motor Module	1
Double Motor Module	2

Power cable:	
MOTION-CONNECT 800	8
MOTION-CONNECT 500	5
Without brake cores	C
With brake cores	D
Length code

Information about the cables
can be found in chapter
Connection system MOTION-CONNECT.

1) Connector size 3 not rotatable. An alternative terminal box can be selected with connector size 3 only.

2) Optimum efficiency in continuous duty.

3) With default setting of the pulse frequency.

4) The current carrying capacity of the power cables complies with EN 60204-1 for installation type C, for continuous duty at an ambient air temperature of 40 °C (104 °F).

5)

$$P_{calc} [kW] = \frac{M_0 [Nm] \times n_{rated}}{9550} \quad P_{calc} [HP] = \frac{M_0 [lb-ft] \times n_{rated}}{5250}$$

Servomotors

Synchronous motors for SINAMICS S120

1FT7 Compact motors Water cooling

Selection and ordering data

Rated speed	Shaft height	Rated power	Static torque	Rated torque	Rated current	1FT7 Compact synchronous motors	Number of pole pairs	Moment of inertia of rotor (without brake)	Weight (without brake)
n_{rated}	SH	P_{rated} at $\Delta T=100\text{ K}$	M_0 at $\Delta T=100\text{ K}$	M_{rated} at $\Delta T=100\text{ K}$	I_{rated} at $\Delta T=100\text{ K}$	Order No.	p	J	m
rpm		kW (HP)	Nm (lb _f -ft)	Nm (lb _f -ft)	A			10^{-4} kgm^2 ($10^{-3}\text{ lb}_f\text{-in-s}^2$)	kg (lb)
Water cooling									
3000	63	3.1 (4.2)	10 (7.4)	10 (7.4)	7.8	1FT7062-5WF7-1 ■■■	5	8.1 (7.17)	11 (24.3)
		5 (6.7)	16 (11.8)	16 (11.8)	12.5	1FT7064-5WF7-1 ■■■	5	12.9 (11.4)	13.7 (30.2)
		6.2 (8.3)	20 (14.8)	19.6 (14.5)	14.4	1FT7066-5WF7-1 ■■■	5	17.7 (15.7)	16.3 (35.9)
		9.3 (12.5)	30 (22.1)	29.5 (21.8)	19.6	1FT7068-5WF7-1 ■■■	5	24.8 (22.0)	20.1 (44.3)
	80	6.28 (8.42)	21 (15.5)	20.5 (15.1)	16	1FT7082-5WF7-1 ■■■	5	28.9 (25.6)	20.7 (45.6)
		11 (14.8)	35 (25.8)	35 (25.8)	24.2	1FT7084-5WF7-1 ■■■	5	48.3 (42.8)	27.5 (60.6)
		15.4 (20.7)	50 (36.9)	49 (36.1)	36	1FT7086-5WF7-1 ■■■	5	67.8 (60.0)	34.1 (75.2)
	100	14.3 (19.2)	50 (36.9)	45.5 (33.6)	38.8	1FT7102-5WF7-1 ■■■	5	98.9 (87.5)	36.6 (80.7)
		24.8 (33.3)	90 (66.4)	79 (58.3)	49.5	1FT7105-5WF7-1 ■■■	5	164 (145.1)	55.9 (123.3)
34.2 (45.9)		125 (92.2)	109 (80.4)	60	1FT7108-5WF7-1 ■■■	5	265 (235)	69.6 (153.5)	
4500	63	9.1 (12.2)	20 (14.8)	19.4 (14.3)	20.8	1FT7066-5WH7-1 ■■■	5	17.7 (15.7)	16.3 (35.9)
		8.95 (12.0)	21 (15.5)	19 (14.0)	23.9	1FT7082-5WH7-1 ■■■	5	28.9 (25.6)	20.7 (45.6)
	80	14.6 (20.0)	35 (25.8)	32 (23.6)	34.5	1FT7084-5WH7-1 ■■■	5	48.3 (42.8)	27.5 (60.6)
		20.3 (406)	50 (36.9)	43 (31.7)	38	1FT7086-5WH7-1 ■■■	5	67.8 (60.0)	34.1 (75.2)
6000	63	5.8 (7.78)	10 (7.4)	9.2 (6.80)	12.7	1FT7062-5WK7-1 ■■■	5	8.1 (7.17)	11 (24.3)
		8.9 (11.9)	16 (11.8)	14.2 (10.5)	20	1FT7064-5WK7-1 ■■■	5	12.9 (11.4)	13.7 (30.2)
Type of construction:		IM B5	Flange 0	0					
			Flange 1 (compatible with 1FT6)	1					
Connector outlet direction:		Connector size 1 and 1.5	Rotatable connector	1					
		Connector size 3 ¹⁾	Transverse right	1					
			Transverse left	2					
			Axial NDE	3					
			Axial DE	4					
Terminal box/ cable entry:¹⁾		Top/transverse from right		5					
		Top/transverse from left		6					
		Top/axial from NDE		7					
		Top/axial from DE		8					
Encoder systems for motors without DRIVE-CLiQ interface:		IC2048S/R encoder		N					
		AM2048S/R encoder		M					
Encoder systems for motors with DRIVE-CLiQ interface:		IC22DQ encoder		D					
		AM22DQ encoder		F					
Shaft extension:		Shaft and flange accuracy:		Holding brake:					
Fitted key and keyway		Tolerance N		Without					A
Fitted key and keyway		Tolerance N		With					B
Fitted key and keyway		Tolerance R		Without					D
Fitted key and keyway		Tolerance R		With					E
Plain shaft		Tolerance N		Without					G
Plain shaft		Tolerance N		With					H
Plain shaft		Tolerance R		Without					K
Plain shaft		Tolerance R		With					L
Vibration magnitude:		Degree of protection:							
Grade A		IP64							0
Grade A		IP65							1
Grade A		IP67							2
Grade R		IP64							3
Grade R		IP65							4
Grade R		IP67							5

To select the type of construction and degree of protection, see Technical definitions.

Servomotors

Synchronous motors for SINAMICS S120

1FT7 Compact motors
Water cooling

Motor type (repeated)	Efficiency ²⁾ η %	Static current I_0 at M_0 $\Delta T=100$ K A	Calculated power P_{calc} ⁶⁾ P_{calc} for M_0 $\Delta T=100$ K kW (HP)	SINAMICS S120 Motor Module		Power cable with complete shield		
				Rated output current ³⁾ I_{rated} A	Booksized format For additional versions and components, see chapter SINAMICS S120 drive system Order No.	Motor connection (and brake connection) via power connector		
						Power connector Size	Cable cross- section ⁴⁾ mm ²	Pre-assembled cable Order No.
1FT7062-5WF7...	91	7.4	3.1 (4.16)	9	6SL312-1-TE21-0AA3	1	4 × 1.5	6FX002-5-N01-....
1FT7064-5WF7...	91	11.9	5.0 (6.7)	18	6SL312-1-TE21-8AA3	1	4 × 1.5	6FX002-5-N01-....
1FT7066-5WF7...	91	14	6.3 (8.5)	18	6SL312-1-TE21-8AA3	1	4 × 1.5	6FX002-5-N01-....
1FT7068-5WF7...	93	19	9.4 (12.6)	18 ⁵⁾	6SL312-1-TE21-8AA3	1	4 × 2.5	6FX002-5-N11-....
1FT7082-5WF7...	94	16	6.6 (8.85)	18	6SL312-1-TE21-8AA3	1.5	4 × 2.5	6FX002-5-N31-....
1FT7084-5WF7...	94	23	11.0 (14.8)	30	6SL312-1-TE23-0AA3	1.5	4 × 4	6FX002-5-N41-....
1FT7086-5WF7...	94	34	15.7 (21.1)	45	6SL312-1-TE24-5AA3	1.5	4 × 6	6FX002-5-N54-....
1FT7102-5WF7...	95	40	15.7 (21.1)	45	6SL312-1-TE24-5AA3	1.5	4 × 10	6FX002-5-N64-....
1FT7105-5WF7...	94	53.2	28.3 (38.0)	60	6SL312-1-TE26-0AA3	3	4 × 16	6FX002-5-S23-....
1FT7108-5WF7...	95	65	39.3 (52.7)	85	6SL312-1-TE28-5AA3	3	4 × 16	6FX002-5-G23-....
1FT7066-5WH7...	91	19.7	9.4 (12.6)	30	6SL312-1-TE23-0AA3	1	4 × 2.5	6FX002-5-N11-....
1FT7082-5WH7...	94	24	9.9 (13.3)	30	6SL312-1-TE23-0AA3	1.5	4 × 4	6FX002-5-N41-....
1FT7084-5WH7...	94	34.3	16.5 (22.1)	45	6SL312-1-TE24-5AA3	1.5	4 × 6	6FX002-5-N54-....
1FT7086-5WH7...	94	40.5	23.6 (31.7)	45	6SL312-1-TE24-5AA3	1.5	4 × 10	6FX002-5-N64-....
1FT7062-5WK7...	92	12.5	6.3 (8.45)	18	6SL312-1-TE21-8AA3	1	4 × 1.5	6FX002-5-N01-....
1FT7064-5WK7...	92	20.2	10.1 (13.5)	30	6SL312-1-TE23-0AA3	1	4 × 2.5	6FX002-5-N11-....

Cooling:	
Internal air cooling	0
External air cooling	1
Motor Module:	
Single Motor Module	1
Double Motor Module	2

Power cable:	
MOTION-CONNECT 800	8
MOTION-CONNECT 500	5
Without brake cores	C
With brake cores	D
Length code

Information about the cables
can be found in chapter
Connection system MOTION-CONNECT.

1) Connector size 3 is not rotatable. An alternative terminal box can be selected with connector size 3 only.

2) Optimum efficiency in continuous duty.

3) With default setting of the pulse frequency.

4) The current carrying capacity of the power cables complies with EN 60204-1 for installation type C, for continuous duty at an ambient air temperature of 40 °C (104 °F).

5) With the specified Motor Module, the motor cannot be fully utilized with M_0 at $\Delta T = 100$ K winding temperature rise. If a Motor Module with a higher rating is used, you must check whether the specified power cable can be connected to it.

6) $P_{calc} [kW] = \frac{M_0 [Nm] \times n_{rated}}{9550}$ $P_{calc} [HP] = \frac{M_0 [lb\text{-}ft] \times n_{rated}}{5250}$

Servomotors

Synchronous motors for SINAMICS S120

1FT7 High Dynamic motors Forced ventilation/Water cooling

Selection and ordering data

Rated speed	Shaft height	Rated power	Static torque	Rated torque	Rated current	1FT7 High Dynamic synchronous motors	Number of pole pairs	Moment of inertia of rotor (without brake)	Weight (without brake)
n_{rated} rpm	SH	P_{rated} at $\Delta T=100$ K kW (HP)	M_0 at $\Delta T=100$ K Nm (lb _f -ft)	M_{rated} at $\Delta T=100$ K Nm (lb _f -ft)	I_{rated} at $\Delta T=100$ K A		Order No.	p	J 10^{-4} kgm ² (10^{-3} lb _f -in-s ²)
Forced ventilation									
3000	63	3.8 (5.10)	14 (10.3)	12 (8.90)	10.5	1FT7065-7S F7-1 ■■■	5	6.4 (5.66)	19 (41.9)
		4.4 (5.90)	17 (12.5)	14 (10.3)	13	1FT7067-7S F7-1 ■■■	5	8.3 (7.35)	23 (50.7)
	80	7.2 (9.66)	34 (25.1)	23 (17.0)	20	1FT7085-7S F7-1 ■■■	5	20.7 (18.3)	34 (75.0)
		10.4 (14.0)	48 (35.4)	33 (24.3)	29	1FT7087-7S F7-1 ■■■	5	27.4 (24.3)	42 (92.6)
4500	63	5.2 (6.97)	14 (10.3)	11 (8.10)	13.5	1FT7065-7SH7-1 ■■■	5	6.4 (5.66)	19 (41.9)
		6.1 (8.18)	17 (12.5)	13 (9.60)	15	1FT7067-7SH7-1 ■■■	5	8.3 (7.35)	23 (50.7)
	80	8.2 (11.0)	34 (25.1)	17.5 (12.9)	22.5	1FT7085-7SH7-1 ■■■	5	20.7 (18.3)	34 (75.0)
		10.8 (14.5)	48 (35.4)	23 (17.0)	24	1FT7087-7SH7-1 ■■■	5	27.4 (24.3)	43 (94.8)
Water cooling									
3000	63	5.7 (7.64)	19 (14.0)	18 (13.3)	15	1FT7065-7WF7-1 ■■■	5	6.4 (5.66)	16 (35.3)
		7.4 (9.92)	25 (18.4)	23.5 (17.3)	21	1FT7067-7WF7-1 ■■■	5	8.3 (7.35)	22 (48.5)
	80	11.9 (16.0)	43 (31.7)	38 (28.0)	32	1FT7085-7WF7-1 ■■■	5	20.7 (18.3)	32 (70.6)
		16.0 (21.5)	61 (45.0)	51 (37.6)	43	1FT7087-7WF7-1 ■■■	5	27.4 (24.3)	41 (90.4)
4500	63	7.8 (10.5)	19 (14.0)	16.5 (12.2)	20	1FT7065-7WH7-1 ■■■	5	6.4 (5.66)	16 (35.3)
		10.4 (14.0)	25 (18.4)	22 (16.2)	25	1FT7067-7WH7-1 ■■■	5	8.3 (7.35)	22 (48.5)
	80	15.6 (20.9)	43 (31.7)	33 (24.3)	48	1FT7085-7WH7-1 ■■■	5	20.7 (18.3)	32 (70.6)
		21.7 (29.1)	61 (45.0)	46 (33.9)	53	1FT7087-7WH7-1 ■■■	5	27.4 (24.3)	41 (90.4)
Type of construction:									
			IM B5	Flange 0	0				
				Flange 1 (compatible with 1FT6)	1				
Connector outlet direction:									
			Connector size 1 and 1.5	Rotatable connector	1				
			Connector size 3 ¹⁾	Transverse right	1				
				Transverse left	2				
				Axial NDE	3				
				Axial DE	4				
Terminal box/cable entry:¹⁾									
			Top/transverse from right		5				
			Top/transverse from left		6				
			Top/axial from NDE		7				
			Top/axial from DE		8				
Encoder systems for motors without DRIVE-CLiQ interface:									
			IC2048S/R encoder		N				
			AM2048S/R encoder		M				
Encoder systems for motors with DRIVE-CLiQ interface: (Only for water cooling)									
			IC22DQ encoder		D				
			AM22DQ encoder		F				
Shaft extension:									
			Fitted key and keyway	Tolerance N					
			Fitted key and keyway	Tolerance N					
			Fitted key and keyway	Tolerance R					
			Fitted key and keyway	Tolerance R					
			Plain shaft	Tolerance N					
			Plain shaft	Tolerance N					
			Plain shaft	Tolerance R					
			Plain shaft	Tolerance R					
Shaft and flange accuracy:									
			Tolerance N						
			Tolerance N						
			Tolerance R						
			Tolerance R						
			Tolerance N						
			Tolerance N						
			Tolerance R						
			Tolerance R						
Holding brake:									
			Without						
			With						
			Without						
			With						
			Without						
			With						
Vibration magnitude:									
			Grade A						
			Grade A						
			Grade A	IP67 (only for water cooling)					
			Grade R						
			Grade R						
			Grade R	IP67 (only for water cooling)					
Degree of protection:									
			IP64						
			IP65						
			IP67 (only for water cooling)						
			IP64						
			IP65						
			IP67 (only for water cooling)						

To select the type of construction and degree of protection, see Technical definitions.

Servomotors

Synchronous motors for SINAMICS S120

1FT7 High Dynamic motors
Forced ventilation/Water cooling

Motor type (repeated)	Efficiency ²⁾ η %	Static current I_0 at M_0 $\Delta T=100$ K A	Calculated power P_{calc} ³⁾ P_{calc} for M_0 $\Delta T=100$ K kW (HP)	SINAMICS S120 Motor Module		Power cable with complete shield		
				Rated output current ³⁾ I_{rated} A	Booksized format For additional versions and components, see chapter SINAMICS S120 drive system Order No.	Motor connection (and brake connection) via power connector	Power connector Size	Conductor cross- section ⁴⁾ mm ²
1FT7065-7SF7...	92	12	4.4 (5.90)	18	6SL312-1-TE21-8AA3	1.5	4 × 1.5	6FX002-5 N21-....
1FT7067-7SF7...	94	15	5.3 (7.11)	18	6SL312-1-TE21-8AA3	1.5	4 × 1.5	6FX002-5 N21-....
1FT7085-7SF7...	92	28	10.7 (14.4)	30	6SL312-1-TE23-0AA3	1.5	4 × 4	6FX002-5 N41-....
1FT7087-7SF7...	93	40	15.1 (20.3)	45	6SL312-1-TE24-5AA3	1.5	4 × 10	6FX002-5 N64-....
1FT7065-7SH7...	92	16	6.6 (8.85)	18	6SL312-1-TE21-8AA3	1.5	4 × 2.5	6FX002-5 N31-....
1FT7067-7SH7...	94	19	8.0 (10.7)	30	6SL312-1-TE23-0AA3	1.5	4 × 2.5	6FX002-5 N31-....
1FT7085-7SH7...	92	40	16.0 (21.5)	45	6SL312-1-TE24-5AA3	1.5	4 × 10	6FX002-5 N64-....
1FT7087-7SH7...	93	45	22.6 (30.3)	45	6SL312-1-TE24-5AA3	3	4 × 10	6FX002-5 S14-....
1FT7065-7WF7...	92	16	6.0 (8.05)	18	6SL312-1-TE21-8AA3	1.5	4 × 2.5	6FX002-5 N31-....
1FT7067-7WF7...	94	22	7.9 (10.6)	30	6SL312-1-TE23-0AA3	1.5	4 × 4	6FX002-5 N41-....
1FT7085-7WF7...	93	36	13.5 (18.1)	45	6SL312-1-TE24-5AA3	1.5	4 × 6	6FX002-5 N54-....
1FT7087-7WF7...	94	51	19.2 (25.8)	60	6SL312-1-TE26-0AA3	3	4 × 16	6FX002-5 S23-....
1FT7065-7WH7...	92	22	9.0 (12.1)	30	6SL312-1-TE23-0AA3	1.5	4 × 4	6FX002-5 N41-....
1FT7067-7WH7...	94	28	11.8 (15.8)	30	6SL312-1-TE23-0AA3	1.5	4 × 4	6FX002-5 N41-....
1FT7085-7WH7...	94	58	20.3 (27.2)	60	6SL312-1-TE26-0AA3	3	4 × 16	6FX002-5 S23-....
1FT7087-7WH7...	94	67	28.7 (38.5)	85	6SL312-1-TE28-5AA3	3	4 × 25	6FX002-5 DG33-....

Cooling:	
Internal air cooling	0
External air cooling	1
Motor Module:	
Single Motor Module	1
Double Motor Module	2

Power cable:	
MOTION-CONNECT 800	8
MOTION-CONNECT 500	5
Without brake cores	C
With brake cores	D
Length code

Information about the cables
can be found in chapter
Connection system MOTION-CONNECT.

1) Connector size 3 is not rotatable. An alternative terminal box can be selected with connector size 3 only.

2) Optimum efficiency in continuous duty.

3) With default setting of the pulse frequency.

4) The current carrying capacity of the power cable complies with EN 60204-1 for installation type C, for continuous duty at an ambient air temperature of 40 °C (104 °F).

5)

$$P_{calc} [kW] = \frac{M_0 [Nm] \times n_{rated}}{9550} \quad P_{calc} [HP] = \frac{M_0 [lb-ft] \times n_{rated}}{5250}$$

Servomotors

Synchronous motors for SINAMICS S120

1FK7 motors

Overview



1FK708/1FK706 High Inertia and 1FK704/1FK703 Compact motors

1FK7 motors are compact, permanent-magnet synchronous motors. The available options, gearboxes and encoders, together with the expanded product range, mean that 1FK7 motors can be optimally adapted to any application. They therefore also satisfy the permanently increasing demands of state-of-the-art machine generations.

1FK7 motors can be combined with the SINAMICS S120 drive system to create a powerful system with high functionality. The integrated encoder systems for speed and position control can be selected depending on the application.

The motors are designed for operation without external cooling and the heat is dissipated through the motor surface. 1FK7 motors have a high overload capability.

Benefits

1FK7 Compact motors offer:

- Space-saving installation due to extremely high power density
- Can be used for universal applications
- Wide range of motors

1FK7 High Dynamic motors offer:

- Extremely high dynamic response due to low rotor moment of inertia

1FK7 High Inertia motors offer:

- Robust closed-loop control properties for high or variable load moment of inertia
- Minimal optimization and commissioning overhead for the compensation of disturbances

Application

- Machine tools
- Robots and handling systems
- Wood, glass, ceramics and stone working
- Packaging, plastics and textile machines
- Auxiliary axes

Technical specifications

1FK7 Compact/1FK7 High Dynamic/1FK7 High Inertia motor	
Type of motor	Permanent-magnet synchronous motor
Magnet material	Rare-earth magnet material
Cooling	Natural cooling
Temperature monitoring	KTY84 temperature sensor in the stator winding
Insulation of the stator winding in accordance with EN 60034-1 (IEC 60034-1)	Temperature class 155 (F) for a winding temperature rise of $\Delta T = 100$ K at an ambient temperature of 40 °C (104 °F)
Type of construction in accordance with EN 60034-7 (IEC 60034-7)	IM B5 (IM V1, IM V3)
Degree of protection in accordance with EN 60034-5 (IEC 60034-5)	IP64/IP65
Shaft extension on the drive end (DE) in accordance with DIN 748-3 (IEC 60072-1)	Plain shaft/fitted key and keyway (half-key balancing)
Shaft and flange accuracy in accordance with DIN 42955 (IEC 60072-1) ¹⁾	Tolerance N
Vibration magnitude in accordance with EN 60034-14 (IEC 60034-14)	Grade A is maintained up to rated speed
Sound pressure level L_{pA} (1 m) in accordance with EN ISO 1680, max. Tolerance + 3 dB	
<ul style="list-style-type: none"> • 1FK701 ... 1FK704 • 1FK706 • 1FK708/1FK710 	55 dB 65 dB 70 dB
Connection	Connectors for signals and power, can be rotated
Paint finish ²⁾	Unpainted
2nd rating plate ²⁾	Attached in the NDE cover
3rd rating plate	Enclosed separately
Holding brake	Without/with
Approvals, according to	cURus

Built-in encoder systems without DRIVE-CLiQ interface

Incremental encoder	
IC2048S/R encoder	Incremental encoder sin/cos 1 V_{pp} 2048 S/R with C and D tracks
Absolute encoder	
AM2048S/R encoder	Absolute encoder 2048 S/R, 4096 revolutions, multi-turn
AM512S/R encoder	Absolute encoder 512 S/R, 4096 revolutions, multi-turn
AM32S/R encoder	Absolute encoder 32 S/R, 4096 revolutions, multi-turn
AM16S/R encoder	Absolute encoder 16 S/R, 4096 revolutions, multi-turn
Resolver	
Multi-pole resolver	Multi-pole resolver (number of pole pairs corresponds to number of pole pairs of the motor)
2-pole resolver	2-pole resolver

Built-in encoder systems with DRIVE-CLiQ interface

Incremental encoder	
IC22DQ encoder	Incremental encoder 22 bit (resolution 4194304, internal 2048 S/R) + commutation position 11 bit
Absolute encoder	
AM22DQ encoder	Absolute encoder 22 bit (resolution 4194304, internal 2048 S/R) + 12 bit multi-turn (traversing range 4096 revolutions)
AM20DQ encoder	Absolute encoder 20 bit (resolution 1048576, internal 512 S/R) + 12 bit multi-turn (traversing range 4096 revolutions)
AM16DQ encoder	Absolute encoder 16 bit (resolution 65536, internal 32 S/R) + 12 bit multi-turn (traversing range 4096 revolutions)
AM15DQ encoder	Absolute encoder 15 bit (resolution 32768, internal 16 S/R) + 12 bit multi-turn (traversing range 4096 revolutions)
Resolver	
R15DQ resolver	Resolver 15 bit (resolution 32768, internal, multi-pole)
R14DQ resolver	Resolver 14 bit (resolution 16384, internal, 2-pole)

S/R=signals/revolution

¹⁾ Shaft extension run-out, concentricity of centering ring and shaft, and perpendicularity of flange to shaft.

²⁾ 1FK701 only available in degree of protection IP54 with paint finish, without rating plate in NDE cover, planetary gearbox not available. 1FK7 High Inertia only available with paint finish and without rating plate in NDE cover.

Servomotors

Synchronous motors for SINAMICS S120

1FK7 motors

Options

Order code	Description
M03	Version for Zone 2 hazardous areas according to EN 50021/IEC 60079-15 (only for 1FK7 Compact/1FK7 High Dynamic)
M39	Version for Zone 22 hazardous areas according to EN 50281/IEC 61241-1 (only for 1FK7 Compact/1FK7 High Dynamic)
N05	Non-standard shaft extension (dimensions as for 1FT5 motors)
N16	Nickel-plated connector and paint finish for increased chemical resistance (only for 1FK7 Compact/1FK7 High Dynamic <u>without</u> DRIVE-CLiQ interface.)
N25	Permanent-magnet brake instead of spring-loaded brake (only for 1FK7 High Dynamic)
Q31	Metal rating plate on motor
X01	Paint finish: Jet black, matt RAL 9005 ¹⁾
X02	Paint finish: Cream white RAL 9001 ¹⁾
X03	Paint finish: Reseda green RAL 6011 ¹⁾
X04	Paint finish: Pebble gray RAL 7032 ¹⁾
X05	Paint finish: Sky blue RAL 5015 ¹⁾
X06	Paint finish: Pale ivory RAL 1015 ¹⁾
X08	Paint finish: Suitable for food grade applications White aluminum RAL 9006 ¹⁾
X27	Paint finish: Dark pearl gray RAL 9023 ¹⁾
K23	Special paint finish for "worldwide" climate group: Primer and paint finish in anthracite RAL 7016 ¹⁾
K23+X..	Special paint finish for "worldwide" climate group: Primer and paint finish selectable from X01 to X27 ²⁾
K24	Primed (unpainted)
J..	Mounting of SP+ planetary gearbox (see geared servomotors)
V..	Mounting of LP+ planetary gearbox (see geared servomotors)

When ordering a motor with options, **-Z** should be added to the order number.

M03

Version for Zone 2 hazardous areas according to IEC EN 60079-15

Combustible or explosive gases or vapors occur only rarely or briefly in Zone 2 areas. The type of protection designation is EEx nA II (non sparking).

The special conditions for operating 1FK7 motors in Zone 2 areas, in particular the reduction in permissible operating speeds, are described in detail in Appendix 610.40063.01 to the EC Declaration of Conformity 664.20025.21.

M39

Version for Zone 22 hazardous areas according to IEC 61241-1

Combustible or potentially explosive dust (non-conductive dust) occurs only rarely or briefly in Zone 22 areas. The type of protection designation is Ex 3D T 150 °C.

The special conditions for operating 1FK7 motors in Zone 22 areas are described in detail in Appendix 610.40071.01 to the EC Declaration of Conformity 664.20031.21.

Note regarding M03 and M39 options:

When used in Zone 2 or Zone 22, 1FK7 motors are only designed for encoder connection through connectors. A version with a DRIVE-CLiQ interface on the motor is not possible. Connection to SINAMICS S120 is only possible via SMC (Sensor Module Cabinet-Mounted).

N05

Non-standard shaft extension (dimensions as for 1FT5 motors)

1FK7 motors are shipped with the following shaft dimensions that are compatible with 1FT5 motors:

- SH 36: 11 × 23 mm (0.43 × 0.91 in)
- SH 48: 14 × 30 mm (0.55 × 1.18 in)
- SH 63: 19 × 40 mm (0.75 × 1.57 in)
- SH 80: 24 × 50 mm (0.94 × 1.97 in)
- SH 100: 32 × 58 mm (1.26 × 2.28 in)

Note:

1FK706 motors with Option N05 do not have a compatible flange with 1FT506 motors.

¹⁾ For the paint finish, 1FK7 Compact/1FK7 High Dynamic motors must be ordered with 3 or 5 in the 16th data position.

²⁾ For primer, 1FK7 Compact/1FK7 High Dynamic motors must be ordered with 0 or 2 in the 16th data position.

Characteristic curves

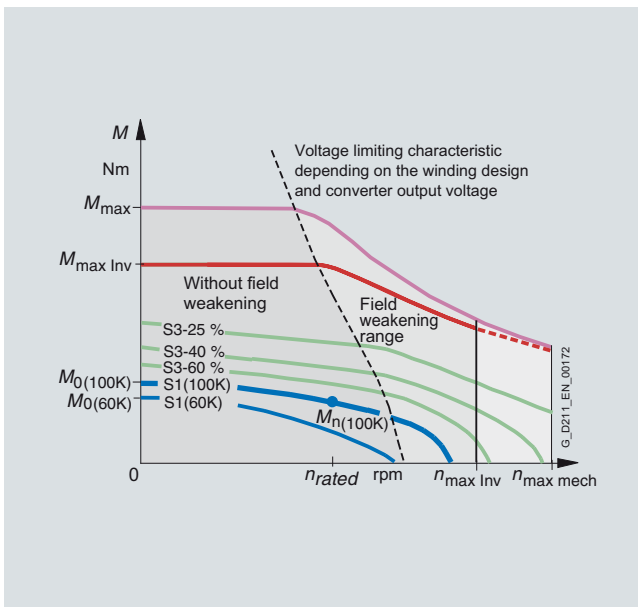

Torque characteristic of a synchronous motor operating on a converter with field weakening (example)

Servomotors

Synchronous motors for SINAMICS S120

1FK7 Compact motors Natural cooling

Selection and ordering data

Rated speed	Shaft height	Rated power	Static torque	Rated torque ¹⁾	Rated current	1FK7 Compact synchronous motor	Number of pole pairs	Moment of inertia of rotor (without brake)	Weight (without brake)
n_{rated}	SH	P_{rated} at $\Delta T=100\text{ K}$	M_0 at $\Delta T=100\text{ K}$	M_{rated} at $\Delta T=100\text{ K}$	I_{rated} at $\Delta T=100\text{ K}$	Order No.	p	J	m
rpm		kW (HP)	Nm (lb _f -ft)	Nm (lb _f -ft)	A			10^{-4} kgm^2 ($10^{-3}\text{ lb}_f\text{-in-s}^2$)	kg (lb)
Natural cooling									
2000	100	4.29 (5.75)	27 (19.9)	20.5 (15.1)	9.6	1FK7101-5AC71-1 ■ ■ ■ ■	4	79.9 (70.7)	21 (46.3)
		5.23 (7.01)	36 (26.6)	25 (18.4)	11.5	1FK7103-5AC71-1 ■ ■ ■ ■	4	105 (92.9)	29 (63.9)
		7.75 (10.4)	48 (35.4)	37 (27.3)	16	1FK7105-5AC71-1 ■ ■ ■ ■	4	156 (138)	39 (86.2)
3000	48	0.82 (1.10)	3.0 (2.2)	2.6 (1.9)	1.95	1FK7042-5AF71-1 ■ ■ ■ ■	4	3.01 (2.66)	4.9 (10.8)
		1.48 (1.98)	6.0 (4.4)	4.7 (3.5)	3.7	1FK7060-5AF71-1 ■ ■ ■ ■	4	7.95 (7.04)	7.0 (15.4)
	63	2.29 (3.07)	11 (8.2)	7.3 (5.4)	5.6	1FK7063-5AF71-1 ■ ■ ■ ■	4	15.1 (13.3)	11.5 (25.4)
		2.14 (2.87)	8.0 (5.9)	6.8 (5.0)	4.4	1FK7080-5AF71-1 ■ ■ ■ ■	4	15.0 (13.2)	10 (22.1)
	80	3.3 (4.43)	16 (11.8)	10.5 (7.7)	7.4	1FK7083-5AF71-1 ■ ■ ■ ■	4	27.3 (24.1)	14 (30.9)
		3.77 (5.06)	18 (13.3)	12.0 (8.8)	8	1FK7100-5AF71-1 ■ ■ ■ ■	4	55.3 (48.9)	19 (41.9)
	100	4.87 (6.53)	27 (19.9)	15.5 (11.4)	11.8	1FK7101-5AF71-1 ■ ■ ■ ■	4	79.9 (70.7)	21 (46.3)
		5.37 (7.20) ²⁾	36 (26.6)	20.5 (15.1) ²⁾	16.5 ²⁾	1FK7103-5AF71-1 ■ ■ ■ ■	4	105 (92.9)	29 (63.9)
		8.17 (11.0)	48 (35.4)	26.0 (19.2)	18	1FK7105-5AF71-1 ■ ■ ■ ■	4	156 (138)	39 (86.2)

Encoder systems for motors without DRIVE-CLiQ interface:

IC2048S/R encoder
AM2048S/R encoder¹⁾
AM32S/R encoder¹⁾
Multi-pole resolver
2-pole resolver

A
E
G
S
T

Encoder systems for motors with DRIVE-CLiQ interface:

IC22DQ encoder
AM22DQ encoder¹⁾
AM16DQ encoder¹⁾
R15DQ resolver
R14DQ resolver

D
F
K
U
P

Shaft extension:

Fitted key and keyway
Fitted key and keyway
Plain shaft
Plain shaft

Shaft and flange accuracy:

Tolerance N
Tolerance N
Tolerance N
Tolerance N

Holding brake:

Without
With
Without
With

A
B
G
H

Degree of protection:

IP64
IP65 and DE flange IP67
IP64 (IP54 for 1FK701) and anthracite paint finish
IP65, DE flange IP67 and anthracite paint finish

0
2
3
5

To select the type of construction and degree of protection, see [Technical definitions](#).

4

Motor type (repeated)	Efficiency ³⁾ η %	Static current I_0 at M_0 $\Delta T=100$ K A	Calculated power P_{calc} ⁷⁾ P_{calc} for M_0 $\Delta T=100$ K kW (HP)	SINAMICS S120 Motor Module		Power cable with complete shield		
				Rated output current ⁴⁾ I_{rated} A	Booksized format For additional versions and components, see chapter SINAMICS S120 drive system Order No.	Motor connection (and brake connection) via power connector		
						Power connector Size	Cable cross- section ⁵⁾ mm ²	Pre-assembled cable Order No.
1FK7101-5AC71...	93	12.3	5.7 (7.64)	18	6SL312-1-TE21-8AA3	1.5	4 × 1.5	6FX002-5S21-....
1FK7103-5AC71...	93	14.7	7.5 (10.0)	18	6SL312-1-TE21-8AA3	1.5	4 × 1.5	6FX002-5S21-....
1FK7105-5AC71...	93	20	10 (13.4)	30	6SL312-1-TE23-0AA3	1.5	4 × 2.5	6FX002-5S31-....
1FK7042-5AF71...	89	2.2	0.9 (1.21)	3	6SL312-1-TE13-0AA3	1	4 × 1.5	6FX002-5S01-....
1FK7060-5AF71...	90	4.5	1.9 (2.55)	5	6SL312-1-TE15-0AA3	1	4 × 1.5	6FX002-5S01-....
1FK7063-5AF71...	91	8	3.5 (4.69)	9	6SL312-1-TE21-0AA3	1	4 × 1.5	6FX002-5S01-....
1FK7080-5AF71...	92	4.8	2.5 (3.35)	5	6SL312-1-TE15-0AA3	1	4 × 1.5	6FX002-5S01-....
1FK7083-5AF71...	93	10.4	5.0 (6.71)	9 ⁶⁾	6SL312-1-TE21-0AA3	1	4 × 1.5	6FX002-5S01-....
1FK7100-5AF71...	92	11.2	5.7 (7.64)	18	6SL312-1-TE21-8AA3	1	4 × 1.5	6FX002-5S01-....
1FK7101-5AF71...	93	19	8.5 (11.4)	18 ⁶⁾	6SL312-1-TE21-8AA3	1.5	4 × 2.5	6FX002-5S31-....
1FK7103-5AF71...	93	27.5	11.3 (15.2)	30	6SL312-1-TE23-0AA3	1.5	4 × 4	6FX002-5S41-....
1FK7105-5AF71...	94	31	15 (20.1)	30 ⁶⁾	6SL312-1-TE23-0AA3	1.5	4 × 6	6FX002-5S51-....

Cooling:	
Internal air cooling	0
External air cooling	1
Motor Module:	
Single Motor Module	1
Double Motor Module	2

Power cable:	
MOTION-CONNECT 800	8
MOTION-CONNECT 500	5
Without brake cores	C
With brake cores	D
Length code

Information about the cables
can be found in chapter
Connection system MOTION-CONNECT.

¹⁾ If the absolute encoder is used, M_{rated} is reduced by 10 %.

²⁾ These values refer to $n = 2500$ rpm.

³⁾ Optimum efficiency in continuous duty.

⁴⁾ With default setting of the pulse frequency.

⁵⁾ The current carrying capacity of the power cables complies with EN 60204-1 for installation type C, for continuous duty at an ambient air temperature of 40 °C (104 °F).

⁶⁾ With the specified Motor Module, the motor cannot be fully utilized with M_0 at $\Delta T = 100$ K winding temperature rise. If a Motor Module with a higher rating is used, you must check whether the specified power cable can be connected to it.

⁷⁾ $P_{calc} [kW] = \frac{M_0 [Nm] \times n_{rated}}{9550}$ $P_{calc} [HP] = \frac{M_0 [lb-ft] \times n_{rated}}{5250}$

Servomotors

Synchronous motors for SINAMICS S120

1FK7 Compact motors Natural cooling

Selection and ordering data

Rated speed	Shaft height	Rated power	Static torque	Rated torque ¹⁾	Rated current	1FK7 Compact synchronous motor	Number of pole pairs	Moment of inertia of rotor (without brake)	Weight (without brake)
n_{rated}	SH	$P_{\text{rated at } \Delta T=100 \text{ K}}$	M_0 at $\Delta T=100 \text{ K}$	$M_{\text{rated at } \Delta T=100 \text{ K}}$	$I_{\text{rated at } \Delta T=100 \text{ K}}$	Order No.	p	J	m
rpm		kW (HP)	Nm (lb _f -ft)	Nm (lb _f -ft)	A			10 ⁻⁴ kgm ² (10 ⁻³ lb _f -in-s ²)	kg (lb)
Natural cooling									
4500	63	1.74 (2.33)	6 (4.43)	3.7 (2.73)	4.1	1FK7060-5AH71-1 ■ ■ ■	4	7.95 (7.04)	7.0 (15.4)
		2.09 (2.81) ²⁾	11 (8.11)	5 (3.69) ²⁾	6.1 ²⁾	1FK7063-5AH71-1 ■ ■ ■	4	15.1 (13.3)	11.5 (25.4)
	80	2.39 (3.21) ²⁾	8 (5.90)	5.7 (4.20) ²⁾	5.6 ²⁾	1FK7080-5AH71-1 ■ ■ ■	4	15 (13.2)	10 (22.1)
		3.04 (4.08) ³⁾	16 (11.8)	8.3 (6.12) ³⁾	9 ³⁾	1FK7083-5AH71-1 ■ ■ ■	4	27.3 (24.1)	14 (30.9)
6000	20	0.05 (0.07)	0.18 (0.13)	0.08 (0.06)	0.85	1FK7011-5AK71-1 ■ ■ ■ 3	4	0.064 (0.06)	0.9 (2.0)
		0.10 (0.13)	0.35 (0.26)	0.16 (0.12)	0.85	1FK7015-5AK71-1 ■ ■ ■ 3	4	0.083 (0.08)	1.1 (2.4)
	28	0.38 (0.51)	0.85 (0.63)	0.6 (0.44)	1.4	1FK7022-5AK71-1 ■ ■ ■	3	0.28 (0.25)	1.8 (4.0)
	36	0.50 (0.67)	1.1 (0.81)	0.8 (0.59)	1.3	1FK7032-5AK71-1 ■ ■ ■	3	0.61 (0.54)	2.7 (6.0)
		0.63 (0.84)	1.6 (1.18)	1 (0.74)	1.3	1FK7034-5AK71-1 ■ ■ ■	3	0.9 (0.80)	3.7 (8.2)
	48	0.69 (0.93)	1.6 (1.18)	1.1 (0.81)	1.7	1FK7040-5AK71-1 ■ ■ ■	4	1.69 (1.50)	3.5 (7.7)
		1.02 (1.37) ⁴⁾	3 (2.21)	1.95 (1.44) ⁴⁾	3.1 ⁴⁾	1FK7042-5AK71-1 ■ ■ ■	4	3.01 (2.66)	4.9 (10.8)
Encoder systems for motors without DRIVE-CLiQ interface:		IC2048S/R encoder				A			
		AM2048S/R encoder (not for 1FK701 ... 1FK703) ¹⁾				E			
		AM512S/R encoder (only for 1FK702/1FK703) ¹⁾				H			
		AM32S/R encoder (not for 1FK701 ... 1FK703) ¹⁾				G			
		AM16S/R encoder (only for 1FK701 ... 1FK703) ¹⁾				J			
		Multi-pole resolver				S			
		2-pole resolver				T			
Encoder systems for motors with DRIVE-CLiQ interface:⁵⁾		IC22DQ encoder (not for 1FK701)				D			
		AM22DQ encoder (not for 1FK701 ... 1FK703) ¹⁾				F			
		AM20DQ encoder (only for 1FK702/1FK703) ¹⁾				L			
		AM16DQ encoder (not for 1FK701 ... 1FK703) ¹⁾				K			
		AM15DQ encoder (only for 1FK702/1FK703) ¹⁾				V			
		R15DQ resolver (not for 1FK701)				U			
		R14DQ resolver (not for 1FK701)				P			
Shaft extension:		Shaft and flange accuracy:		Holding brake:					
Fitted key and keyway		Tolerance N		Without		A			
Fitted key and keyway		Tolerance N		With		B			
Plain shaft		Tolerance N		Without		G			
Plain shaft		Tolerance N		With		H			
Degree of protection:		IP64 (not for 1FK701)				0			
		IP65 and DE flange IP67 (not for 1FK701)				2			
		IP64 (IP54 for 1FK701) and anthracite paint finish				3			
		IP65, DE flange IP67 and anthracite paint finish (not for 1FK701)				5			

To select the type of construction and degree of protection, see Technical definitions.

Servomotors

Synchronous motors for SINAMICS S120

1FK7 Compact motors
Natural cooling

Motor type (repeated)	Efficiency ⁶⁾ η %	Static current I_0 at M_0 $\Delta T=100$ K A	Calculated power P_{calc} ⁹⁾ for M_0 $\Delta T=100$ K kW (HP)	SINAMICS S120 Motor Module		Power cable with complete shield		
				Rated output current ⁷⁾ I_{rated} A	Booksized format For additional versions and components, see chapter SINAMICS S120 drive system Order No.	Motor connection (and brake connection) via power connector		
						Power connector Size	Cable cross-section ⁸⁾ mm ²	Pre-assembled cable Order No.
1FK7060-5AH71...	90	6.2	2.8 (3.75)	9	6SL312-TE21-0AA3	1	4 × 1.5	6FX002-5S01-....
1FK7063-5AH71...	90	12	5.2 (6.97)	18	6SL312-TE21-8AA3	1	4 × 1.5	6FX002-5S01-....
1FK7080-5AH71...	92	7.4	3.8 (5.10)	9	6SL312-TE21-0AA3	1	4 × 1.5	6FX002-5S01-....
1FK7083-5AH71...	93	15	7.5 (10.1)	18	6SL312-TE21-8AA3	1	4 × 1.5	6FX002-5S01-....
1FK7011-5AK71...	62	1.5	0.11 (0.15)	3	6SL312-TE13-0AA3	0.5	4 × 1.5	6FX5 002-5DA20-....
1FK7015-5AK71...	68	1.5	0.22 (0.30)	3	6SL312-TE13-0AA3	0.5	4 × 1.5	6FX5 002-5DA20-....
1FK7022-5AK71...	86	1.8	0.5 (0.67)	3	6SL312-TE13-0AA3	1	4 × 1.5	6FX002-5S01-....
1FK7032-5AK71...	88	1.7	0.7 (0.94)	3	6SL312-TE13-0AA3	1	4 × 1.5	6FX002-5S01-....
1FK7034-5AK71...	88	1.9	1 (1.34)	3	6SL312-TE13-0AA3	1	4 × 1.5	6FX002-5S01-....
1FK7040-5AK71...	88	2.25	1 (1.34)	3	6SL312-TE13-0AA3	1	4 × 1.5	6FX002-5S01-....
1FK7042-5AK71...	89	4.4	1.9 (2.55)	5	6SL312-TE15-0AA3	1	4 × 1.5	6FX002-5S01-....

Cooling:	
Internal air cooling	0
External air cooling	1
Motor Module:	
Single Motor Module	1
Double Motor Module	2

Power cable:	
MOTION-CONNECT 800	8
MOTION-CONNECT 500	5
Without brake cores	C
With brake cores	D
Length code

Information about the cables can be found in chapter Connection system MOTION-CONNECT.

¹⁾ If the absolute encoder is used, M_{rated} is reduced by 10 %.

²⁾ These values refer to $n = 4000$ rpm.

³⁾ These values refer to $n = 3500$ rpm.

⁴⁾ These values refer to $n = 5000$ rpm.

⁵⁾ 1FK701 motors are not available with a DRIVE-CLiQ interface. The encoder systems are connected via the SMC (Sensor Module Cabinet-Mounted).

⁶⁾ Optimum efficiency in continuous duty.

⁷⁾ With default setting of the pulse frequency.

⁸⁾ The current carrying capacity of the power cables complies with EN 60204-1 for installation type C, for continuous duty at an ambient air temperature of 40 °C (104 °F).

⁹⁾ $P_{calc} [kW] = \frac{M_0 [Nm] \times n_{rated}}{9550}$ $P_{calc} [HP] = \frac{M_0 [lb-ft] \times n_{rated}}{5250}$

Servomotors

Synchronous motors for SINAMICS S120

1FK7 High Dynamic motors Natural cooling

Selection and ordering data

Rated speed	Shaft height	Rated power	Static torque	Rated torque ¹⁾	Rated current	1FK7 High Dynamic synchronous motors	Number of pole pairs	Moment of inertia of rotor (without brake)	Weight (without brake)	
n_{rated}	SH	P_{rated} at $\Delta T=100\text{ K}$	M_0 at $\Delta T=100\text{ K}$	M_{rated} at $\Delta T=100\text{ K}$	I_{rated} at $\Delta T=100\text{ K}$	Order No.	p	J	m	
rpm		kW (HP)	Nm (lb _f -ft)	Nm (lb _f -ft)	A			10^{-4} kgm^2 ($10^{-3}\text{ lb}_f\text{-in-s}^2$)	kg (lb)	
Natural cooling										
3000	48	1.1 (1.48)	4 (2.9)	3.5 (2.6)	4	1FK7044-7AF71-1 ■ ■ ■	3	1.28 (1.13)	7.7 (17)	
	63	1.7 (2.28)	6.4 (4.7)	5.4 (4.0)	5.3	1FK7061-7AF71-1 ■ ■ ■	3	3.4 (3.01)	10 (22.1)	
		2.51 (3.37)	12 (8.8)	8 (5.9)	7.5	1FK7064-7AF71-1 ■ ■ ■	3	6.5 (5.75)	15.5 (34.2)	
	80	3.14 (4.21) ²⁾	22 (16.2)	12 (8.8) ²⁾	12.5 ²⁾	1FK7085-7AF71-1 ■ ■ ■	4	23 (20.3)	23.5 (51.8)	
		3.77 (5.06) ³⁾	28 (20.6)	18 (13.3) ³⁾	14.5 ³⁾	1FK7086-7AF71-1 ■ ■ ■	4	23 (20.3)	23.5 (51.8)	
	4500	48	1.23 (1.65)	3.1 (2.3)	2.6 (1.9)	4	1FK7043-7AH71-1 ■ ■ ■	3	1 (0.89)	6.3 (13.9)
1.41 (1.89)			4 (2.9)	3 (2.2)	4.9	1FK7044-7AH71-1 ■ ■ ■	3	1.28 (1.13)	7.7 (17)	
63		2.03 (2.72)	6.4 (4.7)	4.3 (3.2)	5.9	1FK7061-7AH71-1 ■ ■ ■	3	3.4 (3.01)	10 (22.1)	
		2.36 (3.16)	12 (8.8)	5 (3.7)	7	1FK7064-7AH71-1 ■ ■ ■	3	6.5 (5.75)	15.5 (34.2)	
6000		36	0.57 (0.76)	1.3 (1.0)	0.9 (0.7)	1.5	1FK7033-7AK71-1 ■ ■ ■	3	0.27 (0.24)	3.1 (6.8)
		48	1.26 (1.69)	3.1 (2.3)	2 (1.5)	4.4	1FK7043-7AK71-1 ■ ■ ■	3	1 (0.89)	6.3 (13.9)
Encoder systems for motors without DRIVE-CLiQ interface:			IC2048S/R encoder			A E H G J S T				
			AM2048S/R encoder (not for 1FK703) ¹⁾							
			AM512/R encoder (only for 1FK703) ¹⁾							
			AM32S/R encoder (not for 1FK703) ¹⁾							
			AM16S/R encoder (only for 1FK703) ¹⁾							
			Multi-pole resolver							
			2-pole resolver							
Encoder systems for motors with DRIVE-CLiQ interface:			IC22DQ encoder			D F L K V U P				
			AM22DQ encoder (not for 1FK703) ¹⁾							
			AM20DQ encoder (only for 1FK703) ¹⁾							
			AM16DQ encoder (not for 1FK703) ¹⁾							
			AM15DQ encoder (only for 1FK703) ¹⁾							
			R15DQ resolver							
			R14DQ resolver							
Shaft extension:		Shaft and flange accuracy:		Holding brake:		A B G H				
Fitted key and keyway		Tolerance N		Without						
Fitted key and keyway		Tolerance N		With						
Plain shaft		Tolerance N		Without						
Plain shaft		Tolerance N		With						
Degree of protection:			IP64			0 2 3 5				
			IP65 and DE flange IP67							
			IP64 and anthracite paint finish							
			IP65, DE flange IP67 and anthracite paint finish							

To select the type of construction and degree of protection, see Technical definitions.

Servomotors

Synchronous motors for SINAMICS S120

1FK7 High Dynamic motors
Natural cooling

Motor type (repeated)	Efficiency ⁴⁾ η %	Static current I_0 at M_0 $\Delta T=100$ K A	Calculated power P_{calc} ⁷⁾ P_{calc} for M_0 $\Delta T=100$ K kW (HP)	SINAMICS S120 Motor Module		Power cable with complete shield		
				Rated output current ⁵⁾ I_{rated} A	Booksized format For additional versions and components, see chapter SINAMICS S120 drive system Order No.	Motor connection (and brake connection) via power connector		
						Power connector Size	Cable cross section ⁶⁾ mm ²	Pre-assembled cable Order No.
1FK7044-7AF71...	91	4.5	1.3 (1.74)	5	6SL312-TE15-0AA3	1	4 × 1.5	6FX002-5S01-....
1FK7061-7AF71...	93	6.1	2.0 (2.68)	9	6SL312-TE21-0AA3	1	4 × 1.5	6FX002-5S01-....
1FK7064-7AF71...	93	11	3.8 (5.10)	18	6SL312-TE21-8AA3	1	4 × 1.5	6FX002-5S01-....
1FK7085-7AF71...	92	22.5	6.9 (9.25)	30	6SL312-1TE23-0AA3	1.5	4 × 4	6FX002-5S41-....
1FK7086-7AF71...	93	21	8.8 (11.8)	30	6SL312-1TE23-0AA3	1.5	4 × 4	6FX002-5S41-....
1FK7043-7AH71...	90	4.5	1.5 (2.01)	5	6SL312-TE15-0AA3	1	4 × 1.5	6FX002-5S01-....
1FK7044-7AH71...	91	6.3	1.9 (2.55)	9	6SL312-TE21-0AA3	1	4 × 1.5	6FX002-5S01-....
1FK7061-7AH71...	93	8	3.0 (4.02)	9	6SL312-TE21-0AA3	1	4 × 1.5	6FX002-5S01-....
1FK7064-7AH71...	93	15	5.7 (7.64)	18	6SL312-TE21-8AA3	1	4 × 1.5	6FX002-5S01-....
1FK7033-7AK71...	88	2.2	0.8 (1.07)	3	6SL312-TE13-0AA3	1	4 × 1.5	6FX002-5S01-....
1FK7043-7AK71...	90	6.4	1.9 (2.55)	9	6SL312-TE21-0AA3	1	4 × 1.5	6FX002-5S01-....

Cooling:	
Internal air cooling	0
External air cooling	1
Motor Module:	
Single Motor Module	1
Double Motor Module	2

Power cable:	
MOTION-CONNECT 800	8
MOTION-CONNECT 500	5
Without brake cores	C
With brake cores	D
Length code

Information about the cables can be found in chapter Connection system MOTION-CONNECT.

¹⁾ If the absolute encoder is used, M_{rated} is reduced by 10 %.

²⁾ These values refer to $n = 2500$ rpm.

³⁾ These values refer to $n = 2000$ rpm.

⁴⁾ Optimum efficiency in continuous duty.

⁵⁾ With default setting of the pulse frequency.

⁶⁾ The current carrying capacity of the power cables complies with EN 60204-1 for installation type C, for continuous duty at an ambient air temperature of 40 °C (104 °F).

⁷⁾

$$P_{calc} [kW] = \frac{M_0 [Nm] \times n_{rated}}{9550} \quad P_{calc} [HP] = \frac{M_0 [lb-ft] \times n_{rated}}{5250}$$

Servomotors

Synchronous motors for SINAMICS S120

1FK7 Compact/1FK7 High Dynamic motors for 230 V 1 AC Power Modules – natural cooling

Selection and ordering data

Rated speed	Shaft height	Rated power	Static torque	Rated torque ¹⁾	Rated current	1FK7 Compact/High Dynamic synchronous motors Connection to SINAMICS S120 230 V 1 AC Power Modules	Number of pole pairs	Moment of inertia of rotor (without brake)	Weight (without brake)
n_{rated}	SH	$P_{\text{rated at}}$ $\Delta T=100 \text{ K}$	M_0 $\Delta T=100 \text{ K}$	$M_{\text{rated at}}$ $\Delta T=100 \text{ K}$	$I_{\text{rated at}}$ $\Delta T=100 \text{ K}$	Order No.	p	J	m
rpm		kW (HP)	Nm (lb _f -ft)	Nm (lb _f -ft)	A			10^{-4} kgm^2 ($10^{-3} \text{ lb}_f\text{-in-s}^2$)	kg (lb)
Natural cooling									
3000	36	0.31 (0.42)	1.15 (0.85)	1.0 (0.74)	1.6	1FK7032-5AF21-1 ■ ■ ■	3	0.61 (0.54)	2.7 (5.9)
		0.38 (0.51)	1.3 (0.96)	1.2 (0.89)	2	1FK7033-7AF21-1 ■ ■ ■	3	0.27 (0.24)	3.1 (6.8)
		0.46 (0.62)	1.6 (1.18)	1.45 (1.07)	1.8	1FK7034-5AF21-1 ■ ■ ■	3	0.9 (0.8)	3.7 (8.2)
	48	0.82 (1.10)	3 (2.21)	2.6 (1.92)	3.5	1FK7042-5AF21-1 ■ ■ ■	4	3.01 (2.66)	4.9 (10.8)
		0.79 (1.06)	2.7 (1.99)	2.5 (1.84)	3.8	1FK7043-7AF21-1 ■ ■ ■	3	1 (0.89)	6.3 (13.9)
6000	20	0.05 (0.07)	0.18 (0.13)	0.08 (0.06)	0.5	1FK7011-5AK21-1 ■ ■ ■ 3	4	0.064 (0.06)	0.9 (2.0)
		0.10 (0.13)	0.35 (0.26)	0.16 (0.12)	0.5	1FK7015-5AK21-1 ■ ■ ■ 3	4	0.083 (0.08)	1.1 (2.4)
	28	0.38 (0.51)	0.85 (0.63)	0.6 (0.44)	1.4	1FK7022-5AK21-1 ■ ■ ■	3	0.28 (0.25)	1.8 (4.0)
Synchronous motor:			1FK7 Compact		5				
			1FK7 High Dynamic		7				
Encoder systems for motors without DRIVE-CLiQ interface:			IC2048S/R encoder			A			
			AM2048S/R encoder (only for 1FK704) ¹⁾			E			
			AM512/R encoder (only for 1FK702/1FK703) ¹⁾			H			
			AM32S/R encoder (only for 1FK704) ¹⁾			G			
			AM16S/R encoder (not for 1FK704) ¹⁾			J			
			Multi-pole resolver			S			
			2-pole resolver			T			
Encoder systems for motors with DRIVE-CLiQ interface:²⁾			IC22DQ encoder (not for 1FK701)			D			
			AM22DQ encoder (only for 1FK704) ¹⁾			F			
			AM20DQ encoder (only for 1FK702/1FK703) ¹⁾			L			
			AM16DQ encoder (only for 1FK704) ¹⁾			K			
			AM15DQ encoder (only for 1FK702/1FK703) ¹⁾			V			
			R15DQ resolver (not for 1FK701)			U			
			R14DQ resolver (not for 1FK701)			P			
Shaft extension:		Shaft and flange accuracy:		Holding brake:					
Fitted key and keyway		Tolerance N		Without					A
Fitted key and keyway		Tolerance N		With					B
Plain shaft		Tolerance N		Without					G
Plain shaft		Tolerance N		With					H
Degree of protection:			IP64 (not for 1FK701)						0
			IP65 and DE flange IP67 (not for 1FK701)						2
			IP64 (IP54 for 1FK701) and anthracite paint finish						3
			IP65, DE flange IP67 and anthracite paint finish (not for 1FK701)						5

To select the type of construction and degree of protection, see Technical definitions.

Motor type (repeated)	Efficiency ³⁾ η %	Static current I_0 at M_0 $\Delta T=100$ K A	Calculated power P_{calc} ⁷⁾ P_{calc} for M_0 $\Delta T=100$ K kW (HP)	SINAMICS S120 Power Module		Power cable with complete shield		
				Rated output current ⁴⁾ I_{rated} A	Blocksize format without line filter For additional versions and components, see chapter SINAMICS S120 drive system Order No.	Motor connection (and brake connection) via power connector		
						Power connector Size	Cable cross- section ⁵⁾ mm ²	Pre-assembled cable Order No.
1FK7032-5AF21...	85	1.7	0.36 (0.48)	2.3	6SL3210-1SB12-3UA0	1	4 × 1.5	6FX0002-5G01-....
1FK7033-7AF21...	86	2.2	0.41 (0.5)	2.3	6SL3210-1SB12-3UA0	1	4 × 1.5	6FX0002-5G01-....
1FK7034-5AF21...	85	1.9	0.5 (0.67)	2.3	6SL3210-1SB12-3UA0	1	4 × 1.5	6FX0002-5G01-....
1FK7042-5AF21...	89	3.9	0.94 (1.26)	3.9	6SL3210-1SB14-0UA0	1	4 × 1.5	6FX0002-5G01-....
1FK7043-7AF21...	88	3.9	0.85 (1.14)	3.9	6SL3210-1SB14-0UA0	1	4 × 1.5	6FX0002-5G01-....
1FK7011-5AK21...	62	0.85	0.11 (0.15)	0.9	6SL3210-1SB11-0UA0	0.5 ⁶⁾	4 × 1.5	6FX5002-5DA30-....
1FK7015-5AK21...	68	0.85	0.22 (0.30)	0.9	6SL3210-1SB11-0UA0	0.5 ⁶⁾	4 × 1.5	6FX5002-5DA30-....
1FK7022-5AK21...	85	1.8	0.53 (0.71)	2.3	6SL3210-1SB12-3UA0	1	4 × 1.5	6FX0002-5G01-....

Cooling:	
Internal air cooling	0
Motor Module:	
Single Motor Module	1

Power cable:	
MOTION-CONNECT 800	8
MOTION-CONNECT 500	5
Without brake cores	C
With brake cores	D
Length code

Information about the cables
can be found in chapter
Connection system MOTION-CONNECT.

1) If the absolute encoder is used, M_{rated} is reduced by 10 %.

2) 1FK701 motors are not available with a DRIVE-CLiQ interface. The encoder systems are connected via the SMC (Sensor Module Cabinet-Mounted).

3) Optimum efficiency in continuous duty.

4) With default setting of the pulse frequency.

5) The current carrying capacity of the power cables complies with EN 60204-1 for installation type C, for continuous duty at an ambient air temperature of 40 °C (104 °F).

6) This power cable is fitted with a connector with M17 thread at the motor end and brake cores as standard (4 × 1.5 mm² + 2 × 1.5 mm²).

7)
$$P_{calc} [kW] = \frac{M_0 [Nm] \times n_{rated}}{9550} \quad P_{calc} [HP] = \frac{M_0 [lb-ft] \times n_{rated}}{5250}$$

Servomotors

Synchronous motors for SINAMICS S120

1FK7 High Inertia motors Natural cooling

Selection and ordering data

Rated speed	Shaft height	Rated power	Static torque	Rated torque	Rated current	1FK7 High Inertia synchronous motors	Number of pole pairs	Moment of inertia of rotor (without brake)	Weight (without brake)	
n_{rated}	SH	P_{rated} at $\Delta T=100\text{ K}$	M_0 at $\Delta T=100\text{ K}$	M_{rated} at $\Delta T=100\text{ K}$	I_{rated} at $\Delta T=100\text{ K}$	Order No.	p	J	m	
rpm		kW (HP)	Nm (lb _f -ft)	Nm (lb _f -ft)	A			10^{-4} kgm^2 ($10^{-3}\text{ lb}_f\text{-in-s}^2$)	kg (lb)	
Natural cooling										
2000	80	3.1 (4.16)	20 (14.7)	15 (11.1)	7.1	1FK7084-3BC71-1 ■ ■ ■ ■	4	99 (87.6)	22.7 (50.1)	
3000	63	1.5 (2.01)	6 (4.4)	4.7 (3.5)	3.7	1FK7060-3BF71-1 ■ ■ ■ ■	4	12.5 (11.1)	7.8 (17.2)	
		1.6 (2.15)	8 (5.9)	5.1 (3.8)	3.5	1FK7062-3BF71-1 ■ ■ ■ ■	4	23.6 (20.9)	10.6 (23.4)	
	80	2.7 (3.62)	12 (8.9)	8.7 (6.4)	7	1FK7081-3BF71-1 ■ ■ ■ ■	4	49 (43.4)	15.2 (33.5)	
		3.1 (4.16)	20 (14.8)	10 (7.4)	6.8	1FK7084-3BF71-1 ■ ■ ■ ■	4	99 (87.6)	22.7 (50.1)	
6000	48	0.9 (1.21)	3 (2.2)	1.5 (1.1)	2.45	1FK7042-3BK71-1 ■ ■ ■ ■	4	5.05 (4.47)	5.1 (11.3)	
Encoder systems for motors without DRIVE-CLiQ interface:			IC2048S/R encoder			A				
			AM2048S/R encoder							E
Encoder systems for motors with DRIVE-CLiQ interface:			IC22DQ encoder			D				
			AM22DQ encoder							F
Shaft extension:		Shaft and flange accuracy:		Holding brake:		A	B	G	H	
Fitted key		Tolerance N		Without						
Fitted key		Tolerance N		With						
Plain shaft		Tolerance N		Without						
Plain shaft		Tolerance N		With						
Degree of protection:			IP64 and anthracite paint finish			0				
			IP65 and anthracite paint finish							1
			IP65, DE flange IP67 and anthracite paint finish							2

To select the degree of protection and type of construction, see [Technical definitions](#).

Motor type (repeated)	Efficiency ¹⁾	Static current I_0 at M_0 $\Delta T=100$ K	Calculated power P_{calc} ⁴⁾	SINAMICS S120 Motor Module		Power cable with complete shield		
	η			Rated output current ²⁾	Booksized format	Motor connection (and brake connection) via power connector		
	%	A	kW (HP)	I_{rated}	For additional versions and components, see chapter SINAMICS S120 drive system	Power connector	Cable cross- section ³⁾	Pre-assembled cable
				A	Order No.	Size	mm ²	Order No.
1FK7084-3BC71...	93	8.8	4.2 (5.63)	9	6SL312-TE21-0AA3	1	4 × 1.5	6FX002-5N01-....
1FK7060-3BF71...	90	4.5	1.9 (2.55)	5	6SL312-TE15-0AA3	1	4 × 1.5	6FX002-5N01-....
1FK7062-3BF71...	91	5	2.5 (3.35)	5	6SL312-TE15-0AA3	1	4 × 1.5	6FX002-5N01-....
1FK7081-3BF71...	93	9	3.8 (5.10)	9	6SL312-TE21-0AA3	1	4 × 1.5	6FX002-5N01-....
1FK7084-3BF71...	93	12.5	6.3 (8.45)	18	6SL312-TE21-8AA3	1	4 × 1.5	6FX002-5N01-....
1FK7042-3BK71...	89	4.4	1.9 (2.55)	5	6SL312-TE15-0AA3	1	4 × 1.5	6FX002-5N01-....

Cooling:	
Internal air cooling	0
External air cooling	1
Motor Module:	
Single Motor Module	1
Double Motor Module	2

Power cable:	
MOTION-CONNECT 800	8
MOTION-CONNECT 500	5
Without brake cores	C
With brake cores	D
Length code

Information about the cables
can be found in chapter
Connection system MOTION-CONNECT.

¹⁾ Optimum efficiency in continuous duty.

²⁾ With default setting of the pulse frequency.

³⁾ The current carrying capacity of the power cables complies with EN 60204-1 for installation type C, for continuous duty at an ambient air temperature of 40 °C (104 °F).

⁴⁾ $P_{calc} [kW] = \frac{M_0 [Nm] \times n_{rated}}{9550}$ $P_{calc} [HP] = \frac{M_0 [lb-ft] \times n_{rated}}{5250}$

Servomotors

Selection guides

Built-in holding brakes for 1FT7/1FK7 motors

Overview

Many drives need a holding brake with an emergency stop function for safety reasons or to meet process requirements.

The permanent-magnet or spring-loaded, single-face brakes used for the 1FT7/1FK7 motors function according to the closed-circuit current principle. The magnetic field of the permanent magnet exerts a tension on the brake anchor plate, i.e. in a condition of zero current, the brake is closed and the motor shaft thereby stopped. When the rated voltage of 24 V DC \pm 10 % is applied to the brake, current flows through the coil and produces a counter-field that cancels the pull of the permanent magnet, causing the brake to release.

The spring-loaded, single-face brake operates by the force of pressure exerted by the spring instead of a permanent magnet.

In the event of an emergency stop or power outage, approximately 2000 braking operations can be performed with the maximum switched energy without causing excessive wear on the holding brake (condition: maximum external moment of inertia = moment of inertia of motor and n_{max} type-specific).

The holding brake is not an operational brake.

In order to avoid switching overvoltages and any related effects on the plant environment, the brake cables must be connected externally with a varistor. The connection is made via the power connector or the terminal box.

When connected to the SINAMICS S120 drive system, this overvoltage protection is already included.

Technical specifications

Motor Shaft height SH	Type	Built-in holding brake					
		Holding torque ¹⁾	Direct current	Opening time with varistor	Closing time with varistor	Moment of inertia J	Maximum switched energy per brake operation from $n = 3000$ rpm
		Nm (lb _r -ft)	A	ms	ms	10^{-4} kgm ² (10^{-3} lb _r -in-s ²)	J
1FT7 motors with permanent-magnet brake, without play							
36	1FT703	3 (2.2)	0.3	60	25	0.12 (0.11)	30
48	1FT704	8 (5.9)	0.6	90	30	0.87 (0.77)	270
63	1FT706	18 (13.3)	0.8	150	50	2.84 (2.51)	880
80	1FT708	48 (35.4)	1.0	220	65	15.4 (13.6)	1900
100	1FT710	85 (62.7)	1.6	250	70	27.6 (24.4)	5300
1FK7 Compact motors with permanent-magnet brake, without play							
20	1FK701	0.4 (0.3)	0.3	30	20	0.019 (0.02)	2
28	1FK7022	1.1 (0.8)	0.3	30	20	0.07 (0.06)	8
36	1FK7032	1.3 (1.0)	0.4	50	30	0.08 (0.07)	17
48	1FK704	3.2 (2.4)	0.6	70	30	0.72 (0.64)	74
63	1FK706	13 (9.6)	0.8	100	50	2.25 (1.99)	400
80	1FK7080	10 (7.4)	0.7	100	50	3.1 (2.74)	400
80	1FK7083	22 (16.2)	0.9	200	60	8.6 (7.61)	1400
100	1FK7100	22 (16.2)	0.9	200	60	8.6 (7.61)	1400
100	1FK7101 1FK7103 1FK7105	41 (30.2)	1.0	300	70	13.5 (11.9)	3000
1FK7 High Dynamic motors with spring-loaded, single-face brake²⁾							
36	1FK703	1.3 (1.0)	0.45	100	40	0.12 (0.11)	14
48	1FK704	4 (3.0)	0.6	150	50	0.13 (0.12)	96
63	1FK706	12 (8.9)	0.8	150	50	0.34 (0.30)	230
80	1FK708	22 (16.2)	1.2	200	60	2.0 (1.77)	700
1FK7 High Inertia motors with permanent-magnet brake, without play							
48	1FK704	4 (3.0)	0.5	90	15	0.32 (0.28)	150
63	1FK706	13 (9.6)	0.8	130	20	0.99 (0.88)	400
80	1FK708	22 (16.2)	0.9	150	30	3.28 (2.90)	1400

¹⁾ The holding torque is the highest permissible torque with which the closed brake can be loaded in steady-state operation without slip (holding function when motor is stationary).

²⁾ Permanent-magnet brake without play is available as an option.

Overview

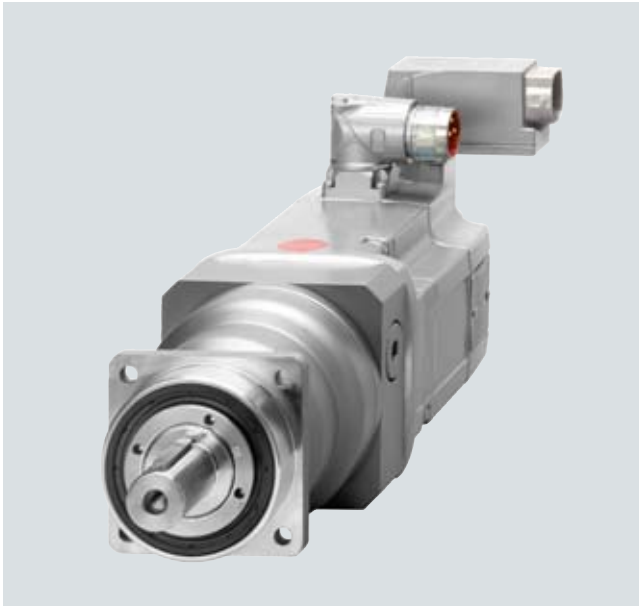

1FT7 motor with mounted series SP+ planetary gearbox

1FT7 motors can be combined with planetary gearboxes to form compact coaxial drive units. The gearboxes are flanged directly to the drive end of the motors.

When selecting the gearbox, ensure that its maximum permissible input speed is not exceeded by the maximum speed of the motor. In the case of high operating frequencies, allowance must be made for the factor f_2 (see Configuration Manual for 1FT7 synchronous motors). The frictional losses of the gearbox must always be taken into account.

The gearboxes are only available in non-balanced design.

Benefits

- High efficiency
Single-stage: > 97 %
Two-stage: > 94 %
- Minimum torsional backlash
Single-stage: ≤ 4 arcmin
Two-stage: ≤ 6 arcmin
- Power transmission from the central sun wheel via planet wheels
- No shaft deflections in the planet wheel set due to symmetrical force distribution
- Very low moment of inertia and thus short acceleration times of the motors
- Output shaft bearings dimensioned for high cantilever and axial loads with preloaded tapered-roller bearings
- The gearboxes are connected to the motor shaft via an integrated clamping hub. A plain motor shaft extension is necessary for this purpose. Shaft and flange accuracy tolerance N in accordance with DIN 42955 and vibration magnitude grade A in accordance with EN 60034-14 are sufficient. The motor flange is adapted by means of adapter plates.
- Output shaft of gearbox exactly coaxial with the motor
- The gearboxes are enclosed (seal between gearbox and motor) and filled with oil at the factory. They are lubricated and sealed for their service life.
The gearboxes are suitable for all mounting positions.
- Degree of protection of gearbox: IP65
- Small dimensions
- Low weight

Integration

1FT703 to 1FT710 motors can be supplied ex factory (Siemens AG) complete with flange-mounted planetary gearbox.

The gearboxes assigned to the individual motors and gear ratios i available for these motor/gearbox combinations are listed in the subsequent selection table. When making a selection, note the maximum permissible input speed of the gearbox (this is the same as the maximum motor speed).

The motor/gearbox combinations listed in the selection tables are mainly intended for cycle operation S3-60 % (ON time ≤ 60 % and ≤ 20 min). Reduced maximum motor speeds and output torques apply for use in S1 continuous duty (ON time > 60 % or > 20 min). The gearbox temperature may not exceed 90 °C (194 °F).

Follow the instructions contained in the Configuration Manual for 1FT7 synchronous motors when assigning gearboxes to the motor.

Servomotors

Geared servomotors for SINAMICS S120

1FT7 motors with SP+ planetary gearbox

Selection and ordering data

Motor Type	Planetary gearbox single-stage		Available gear ratio $i =$				Motor speed, max. S3-60 % n_{G1} (n_1) rpm	Output torque, max. S3-60 % M_{G2} (T_{2B}) Nm (lb _r -ft)	Radial output shaft loading, max. ¹⁾ F_r (F_{2Rmax}) N (lb _r)	Axial output shaft loading, max. ¹⁾ F_a (F_{2Amax}) N (lb _r)	
	Type	Torsional backlash arcmin	Gearbox weight, approx. kg (lb)	4	5	7					10
1FT7034	SP 060S-MF1	≤ 4	1.9 (4.2)	✓	✓	✓	–	6000	40 (29.5)	2700 (607)	2400 (540)
1FT7034	SP 075S-MF1	≤ 4	3.9 (8.6)	–	–	–	✓	6000	110 (81.1) (90 for $i = 10$)	4000 (899)	3350 (753)
1FT7036				✓	✓	✓	✓				
1FT7042				✓	✓	✓	✓				
1FT7044				✓	✓	✓	✓				
1FT7046				✓	✓	✓	–				
1FT7046	SP 100S-MF1	≤ 3	7.7 (17.0)	–	–	–	✓	4500	300 (221) (225 for $i = 10$)	6300 (1416)	5650 (1270)
1FT7062				✓	✓	✓	✓				
1FT7064				✓	✓	✓	✓				
1FT7065				✓	✓	✓	✓				
1FT7066				✓	✓	✓	✓				
1FT7067				✓	✓	✓	–				
1FT7068				✓	✓	✓	–				
1FT7067				SP 140S-MF1	≤ 3	17.2 (37.9)	–				
1FT7068	–	–	–				✓				
1FT7082	✓	✓	✓				✓				
1FT7084	✓	✓	✓				✓				
1FT7085	✓	✓	✓				–				
1FT7086	✓	✓	✓				–				
1FT7087	✓	✓	–				–				
1FT7085	SP 180S-MF1	≤ 3	34 (75)	–	–	–	✓	3500	1100 (811) (880 for $i = 10$)	14700 (3305)	14150 (3181)
1FT7086				–	–	–	✓				
1FT7087				–	–	✓	✓				
1FT7102				✓	✓	✓	✓				
1FT7105	SP 210S-MF1	≤ 3	56 (123)	–	–	–	✓	2500	2500 (1844) (2400 for $i = 7$ 1900 for $i = 10$)	21000 (4721)	30000 (6744)
1FT7108				–	–	–	✓				
				–	–	–	–				
Gear shaft			Order code								
With fitted key			J02	J03	J05	J09					
Without fitted key			J22	J23	J25	J29					

Preconditions:

With the following motor versions, SP+ planetary gearboxes can be mounted:

- Flange 1
- Plain motor shaft extension, shaft and flange accuracy tolerance N, without/with holding brake
- Vibration magnitude grade A/IP65 degree of protection

SP+ planetary gearbox can therefore only be ordered with these 1FT7 motors:

1FT7...-5..71-..G1
1FT7...-5..71-..H1
1FT7...-7..71-..G1
1FT7...-7..71-..H1

When ordering a motor with gearbox, **-Z** should be added to the order number.

Example:

1FT7042 motor without holding brake
with single-stage SP+ planetary gearbox
with $i = 5$ and gear shaft without fitted key.

1FT7042-5AF71-1NG1-**Z**
J23

✓ Possible

– Not possible

¹⁾ In reference to the output shaft center.

Servomotors

Geared servomotors for SINAMICS S120

1FT7 motors with SP+ planetary gearbox

Technical specifications

1FT7 motor with SP+ planetary gearbox

Single-stage Type	Gear ratio <i>i</i>	Motor speed n_{N1} rpm	Output torque Continuous duty S1 ¹⁾ $M_{N2} (T_{2N})$ Nm (lb _r -ft)	Moments of inertia of gearbox (referred to the drive)				
				1FT703.	1FT704.	1FT706.	1FT708.	1FT710.
				J_1 kgcm ² (lb _r -in ²)	J_1 kgcm ² (lb _r -in ²)	J_1 kgcm ² (lb _r -in ²)	J_1 kgcm ² (lb _r -in ²)	J_1 kgcm ² (lb _r -in ²)
SP 060S-MF1	4	3300	26 (19.2)	0.22 (0.08)	–	–	–	–
	5	3300	26 (19.2)	0.20 (0.07)	–	–	–	–
	7	4000	26 (19.2)	0.18 (0.06)	–	–	–	–
SP 075S-MF1	4	2900	75 (55.3)	0.61 (0.21)	0.78 (0.27)	–	–	–
	5	2900	75 (55.3)	0.51 (0.17)	0.68 (0.23)	–	–	–
	7	3100	75 (55.3)	0.42 (0.14)	0.59 (0.20)	–	–	–
	10	3100	52 (38.4)	0.38 (0.13)	0.54 (0.19)	–	–	–
SP 100S-MF1	4	2500	180 (133)	–	–	3.04 (1.04)	–	–
	5	2500	175 (129)	–	–	2.61 (0.89)	–	–
	7	2800	170 (125)	–	–	2.29 (0.78)	–	–
	10	2800	120 (88.5)	–	1.38 (0.47)	2.07 (0.71)	–	–
SP 140S-MF1	4	2100	360 (266)	–	–	–	11.0 (3.76)	–
	5	2100	360 (266)	–	–	–	9.95 (3.40)	–
	7	2600	360 (266)	–	–	–	9.01 (3.08)	–
	10	2600	220 (162)	–	–	5.28 (1.80)	8.44 (2.88)	–
SP 180S-MF1	4	1500	750 (553)	–	–	–	–	33.9 (11.6)
	5	1500	750 (553)	–	–	–	–	27.9 (9.53)
	7	2300	750 (553)	–	–	–	22.2 (7.59)	22.2 (7.59)
	10	2300	750 (553)	–	–	–	19.2 (6.56)	19.2 (6.56)
SP 210S-MF1	10	2000	1000 (738)	–	–	–	–	53.1 (18.1)

¹⁾ The limit values in the table apply for S1 continuous duty (ON time > 60 % or > 20 min) for a maximum gearbox temperature of 90 °C (194 °F).

Servomotors

Geared servomotors for SINAMICS S120

1FT7 motors with SP+ planetary gearbox

Selection and ordering data

Motor Type	Planetary gearbox two-stage		Available gear ratio $i =$					Motor speed, max. S3-60 % n_{G1} (n_1) rpm	Output torque, max. S3-60 % M_{G2} (T_{2B}) Nm (lb _r -ft)	Radial output shaft loading, max. ¹⁾ F_r (F_{2Rmax}) N (lb _f)	Axial output shaft loading, max. ¹⁾ F_a (F_{2Amax}) N (lb _f)	
	Type	Torsional backlash arcmin	Gearbox weight, approx. kg (lb)	16	20	28	40					50
1FT7034 1FT7036	SP 075S-MF2	≤ 6	3.6 (7.9)	✓	✓	✓	-	-	6000	110 (81.1)	4000 (899)	3350 (753)
1FT7042				✓	-	-	-	-				
1FT7034 1FT7036	SP 100S-MF2	≤ 5	7.9 (17.4)	-	-	-	✓	✓	4500	300 (221)	6300 (1416)	5650 (1270)
1FT7042				-	✓	✓	✓	✓				
1FT7044				✓	✓	✓	-	-				
1FT7046				✓	✓	-	-	-				
1FT7062				✓	-	-	-	-				
1FT7064				✓	-	-	-	-				
1FT7044 1FT7046	SP 140S-MF2	≤ 5	17 (37.5)	-	-	-	✓	✓	4000	600 (443)	9450 (2124)	9870 (2219)
1FT7062				-	-	✓	✓	✓				
1FT7064				-	✓	✓	-	-				
1FT7065				✓	✓	-	-	-				
1FT7066				✓	✓	-	-	-				
1FT7067				✓	-	-	-	-				
1FT7068				✓	✓	-	-	-				
1FT7082				✓	✓	-	-	-				
1FT7084				✓	-	-	-	-				
1FT7064 1FT7065 1FT7066 1FT7067 1FT7068	SP 180S-MF2	≤ 5	36.4 (80.3)	-	-	-	✓	✓	4000	1100 (811)	14700 (3305)	14150 (3181)
1FT7082				-	-	✓	✓	✓				
1FT7084				-	✓	✓	-	-				
1FT7085				✓	-	-	-	-				
1FT7086				✓	✓	-	-	-				
1FT7102				✓	✓	-	-	-				
1FT7084 1FT7085 1FT7086 1FT7087	SP 210S-MF2	≤ 5	55 (121)	-	-	-	✓	✓	3500	2400 (1770) (2500 for $i = 20$)	21000 (4721)	30000 (6744)
1FT7102				-	-	✓	-	-				
1FT7105				✓	✓	-	-	-				
1FT7108				✓	-	-	-	-				
1FT7085 1FT7086	SP 240S-MF2	≤ 5	80.6 (178)	-	-	-	✓	✓	3500	4500 (3319) (4000 for $i = 40$ 4300 for $i = 50$)	30000 (6744)	33000 (7419)
1FT7102				-	-	-	✓	✓				
1FT7105				-	-	✓	✓	-				
1FT7108				-	✓	✓	-	-				
	Gear shaft			Order code								
	With fitted key			J12	J13	J15	J16	J17				
	Without fitted key			J32	J33	J35	J36	J37				

Preconditions, see page 4/46.

✓ Possible

- Not possible

¹⁾ In reference to the output shaft center.

Servomotors

Geared servomotors for SINAMICS S120

1FT7 motors with SP+ planetary gearbox

Technical specifications

1FT7 motor with SP+ planetary gearbox

Two-stage Type	Gear ratio <i>i</i>	Motor speed n_{N1} rpm	Output torque Continuous duty S1 ¹⁾ $M_{N2} (T_{2N})$ Nm (lb _r -ft)	Moments of inertia of gearbox (referred to the drive)				
				1FT703.	1FT704.	1FT706.	1FT708.	1FT710.
				J_1 kgcm ² (lb _r -in ²)	J_1 kgcm ² (lb _r -in ²)	J_1 kgcm ² (lb _r -in ²)	J_1 kgcm ² (lb _r -in ²)	J_1 kgcm ² (lb _r -in ²)
SP 075S-MF2	16	3500	75 (55.3)	0.23 (0.08)	0.55 (0.19)	–	–	–
	20	3500	75 (55.3)	0.20 (0.07)	–	–	–	–
	28	3500	75 (55.3)	0.18 (0.06)	–	–	–	–
SP 100S-MF2	16	3100	180 (133)	–	0.81 (0.28)	2.18 (0.75)	–	–
	20	3100	180 (133)	0.54 (0.19)	0.70 (0.24)	2.07 (0.71)	–	–
	28	3100	180 (133)	0.43 (0.15)	0.60 (0.21)	–	–	–
	40	3100	180 (133)	0.38 (0.13)	0.55 (0.19)	–	–	–
	50	3500	175 (129)	0.38 (0.13)	0.54 (0.19)	–	–	–
SP 140S-MF2	16	2900	360 (265)	–	–	3.19 (1.09)	10.3 (3.52)	–
	20	2900	360 (265)	–	–	2.71 (0.93)	9.77 (3.34)	–
	28	2900	360 (265)	–	1.65 (0.56)	2.34 (0.80)	–	–
	40	2900	360 (265)	–	1.40 (0.48)	2.10 (0.72)	–	–
	50	3200	360 (265)	–	1.39 (0.48)	2.08 (0.71)	–	–
SP 180S-MF2	16	2700	750 (553)	–	–	–	12.4 (4.24)	13.5 (4.61)
	20	2700	750 (553)	–	–	7.27 (2.48)	10.9 (3.73)	12.0 (4.10)
	28	2700	750 (553)	–	–	6.32 (2.16)	9.48 (3.24)	–
	40	2700	750 (553)	–	–	5.51 (1.88)	8.67 (2.96)	–
	50	2900	750 (553)	–	–	5.45 (1.86)	8.61 (2.94)	–
SP 210S-MF2	16	2500	1500 (1106)	–	–	–	34.5 (11.8)	34.5 (11.8)
	20	2500	1500 (1106)	–	–	–	31.5 (10.8)	31.5 (10.8)
	28	2500	1500 (1106)	–	–	–	30.0 (10.3)	30.0 (10.3)
	40	2500	1500 (1106)	–	–	–	28.5 (9.74)	–
	50	2500	1500 (1106)	–	–	–	28.3 (9.67)	–
SP 240S-MF2	20	2500	2500 (1844)	–	–	–	–	34.6 (11.8)
	28	2500	2500 (1844)	–	–	–	–	30.5 (10.4)
	40	2500	2500 (1844)	–	–	–	28.2 (9.64)	28.2 (9.64)
	50	2500	2500 (1844)	–	–	–	27.9 (9.53)	27.9 (9.53)

¹⁾ The limit values in the table apply for S1 continuous duty (ON time > 60 % or > 20 min) for a maximum gearbox temperature of 90 °C (194 °F).

Servomotors

Geared servomotors for SINAMICS S120

1FK7 motors with SP+ planetary gearbox

Overview

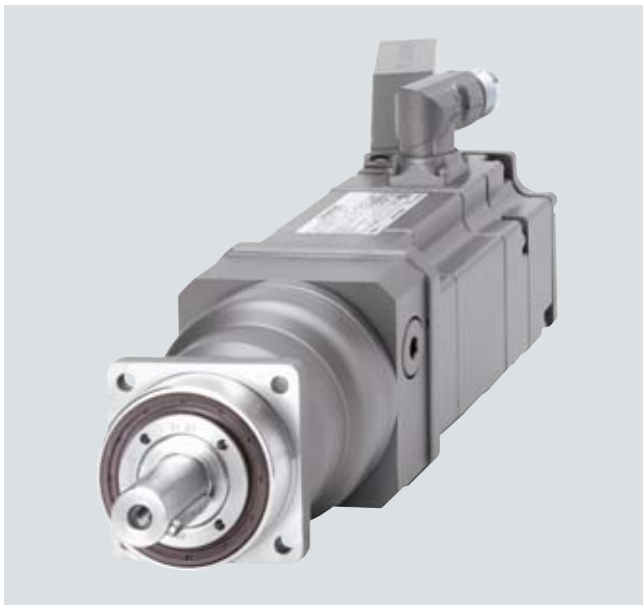

1FK7 motor with mounted series SP+ planetary gearbox

1FK7 motors can easily be combined with planetary gearboxes to form compact coaxial drive units. The gearboxes are flanged directly to the drive end of the motors.

When selecting the gearbox, ensure that its maximum permissible input speed is not exceeded by the maximum speed of the motor. In the case of high operating frequencies, allowance must be made for the factor f_2 (see Configuration Manual for 1FK7 synchronous motors). The frictional losses of the gearbox must always be taken into account.

The gearboxes are only available in non-balanced design.

Benefits

- High efficiency
Single-stage: > 97 %
Two-stage: > 94 %
- Minimum torsional backlash
Single-stage: ≤ 4 arcmin
2-stage: ≤ 6 arcmin
- Power transmission from the central sun wheel via planet wheels
- No shaft deflections in the planet wheel set due to symmetrical force distribution
- Very low moment of inertia and thus short acceleration times of the motors
- Output shaft bearings dimensioned for high cantilever and axial loads with preloaded tapered-roller bearings
- The gearboxes are connected to the motor shaft via an integrated clamping hub. A plain motor shaft extension is necessary for this purpose. Shaft and flange accuracy tolerance N in accordance with DIN 42955 and vibration magnitude grade A in accordance with EN 60034-14 are sufficient. The motor flange is adapted by means of adapter plates.
- Output shaft of gearbox exactly coaxial with the motor
- The gearboxes are enclosed (seal between gearbox and motor) and filled with oil at the factory. They are lubricated and sealed for their service life.
The gearboxes are suitable for all mounting positions.
- Degree of protection of gearbox: IP65
- Small dimensions
- Low weight

Integration

1FK702 to 1FK710 motors can be supplied ex works (Siemens AG) complete with flange-mounted planetary gearbox.

The gearboxes assigned to the individual motors and gear ratios i available for these motor/gearbox combinations are listed in the subsequent selection table. When making a selection, note the maximum permissible input speed of the gearbox (this is the same as the maximum motor speed).

The motor/gearbox combinations listed in the selection table are mainly intended for cycle operation S3-60 % (ON time ≤ 60 % and ≤ 20 min). Reduced maximum motor speeds and output torques apply for use in S1 continuous duty (ON time > 60 % or > 20 min). The gearbox temperature may not exceed 90 °C (194 °F).

Follow the instructions contained in the Configuration Manual for 1FK7 synchronous motors when assigning gearboxes to the motor.

Servomotors

Geared servomotors for SINAMICS S120

1FK7 motors with SP+ planetary gearbox

Selection and ordering data

Motor Type	Planetary gearbox single-stage		Available gear ratio $i =$				Motor speed, max. S3-60 % n_{G1} (n_1) rpm	Output torque, max. S3-60 % M_{G2} (T_{2B}) Nm (lb _r -ft)	Radial output shaft loading, max. ¹⁾ F_r (F_{2Rmax}) N (lb _r)	Axial output shaft loading, max. ¹⁾ F_a (F_{2Amax}) N (lb _r)	
	Type	Torsional backlash arcmin	Gearbox weight, approx. kg (lb)	4	5	7					10
1FK7022	SP 060S-MF1	≤ 4	1.9 (4.2)	✓	✓	✓	✓	6000	40 (295) (32 for $i = 10$)	2700 (607)	2400 (540)
1FK7032				✓	✓	✓	✓				
1FK7033				✓	✓	✓	✓				
1FK7034				✓	✓	✓	✓				
1FK7040	SP 075S-MF1	≤ 4	3.9 (8.6)	✓	✓	✓	✓	6000	110 (81.1) (90 for $i = 10$)	4000 (899)	3350 (753)
1FK7042				✓	✓	✓	✓				
1FK7043				✓	✓	✓	✓				
1FK7044				✓	✓	✓	✓				
1FK7060	SP 100S-MF1	≤ 3	7.7 (17.0)	✓	✓	✓	✓	4500	300 (221) (225 for $i = 10$)	6300 (1416)	5650 (1270)
1FK7061				✓	✓	✓	✓				
1FK7062				✓	✓	✓	✓				
1FK7063				✓	✓	✓	✓				
1FK7064				✓	✓	✓	✓				
1FK7080	SP 140S-MF1	≤ 3	17.2 (37.9)	✓	✓	✓	✓	4000	600 (442) (480 for $i = 10$)	9450 (2124)	9870 (2219)
1FK7081				✓	✓	✓	✓				
1FK7083				✓	✓	✓	✓				
1FK7084				✓	✓	✓	✓				
1FK7085				✓	✓	✓	✓				
1FK7086				✓	✓	✓	✓				
1FK7100	SP 180S-MF1	≤ 3	34 (75.0)	✓	✓	✓	✓	3500	1100 (810) (880 for $i = 10$)	14700 (3305)	14150 (3181)
1FK7101				✓	✓	✓	✓				
1FK7103				✓	✓	✓	✓				
1FK7105				✓	✓	✓	–				
1FK7105	SP 210S-MF1	≤ 3	56 (123)	–	–	–	✓	2500	2500 (1844) (2400 for $i = 7$ 1900 for $i = 10$)	21000 (4721)	30000 (6744)
Gear shaft				Order code							
With fitted key				J02	J03	J05	J09				
Without fitted key				J22	J23	J25	J29				

Preconditions:

With the following motor versions, SP+ planetary gearboxes can be mounted:

- Plain motor shaft extension, shaft and flange accuracy tolerance N, without/with holding brake
- IP65 degree of protection and anthracite paint finish

SP+ planetary gearboxes can therefore only be ordered with these 1FK7 motors:

1FK7...-3B.71-1.G1
1FK7...-3B.71-1.H1
1FK7...-A..1-1.G5
1FK7...-A..1-1.H5

When ordering a motor with gearbox, **-Z** should be added to the order number.

Example:

1FK7042 motor without holding brake with single-stage SP+ planetary gearbox with $i = 7$ and gear shaft without fitted key.
1FK7042-5AF71-1AG5-**Z**
J25

✓ Possible

– Not possible

¹⁾ In reference to the output shaft center.

Servomotors

Geared servomotors for SINAMICS S120

1FK7 motors with SP+ planetary gearbox

Technical specifications

1FK7 motor with SP+ planetary gearbox

Single-stage Type	Gear ratio <i>i</i>	Motor speed n_{N1} rpm	Output torque Continuous duty S1 ¹⁾ $M_{N2} (T_{2N})$ Nm (lb _f -ft)	Moments of inertia of gearbox (referred to the drive)					
				1FK702.	1FK703.	1FK704.	1FK706.	1FK708.	1FK710.
				J_1 kgcm ² (lb _f -in ²)	J_1 kgcm ² (lb _f -in ²)	J_1 kgcm ² (lb _f -in ²)	J_1 kgcm ² (lb _f -in ²)	J_1 kgcm ² (lb _f -in ²)	J_1 kgcm ² (lb _f -in ²)
SP 060S-MF1	4	3300	26 (19.2)	0.15 (0.05)	0.22 (0.08)	–	–	–	–
	5	3300	26 (19.2)	0.12 (0.04)	0.20 (0.07)	–	–	–	–
	7	4000	26 (19.2)	0.10 (0.034)	0.18 (0.062)	–	–	–	–
	10	4000	17 (12.5)	0.09 (0.031)	0.17 (0.058)	–	–	–	–
SP 075S-MF1	4	2900	75 (55.3)	–	–	0.78 (0.27)	–	–	–
	5	2900	75 (55.3)	–	–	0.68 (0.23)	–	–	–
	7	3100	75 (55.3)	–	–	0.59 (0.20)	–	–	–
	10	3100	52 (38.4)	–	–	0.54 (0.19)	–	–	–
SP 100S-MF1	4	2500	180 (133)	–	–	–	3.04 (1.04)	–	–
	5	2500	175 (129)	–	–	–	2.61 (0.89)	–	–
	7	2800	170 (125)	–	–	–	2.29 (0.78)	–	–
	10	2800	120 (88.5)	–	–	–	2.07 (0.71)	–	–
SP 140S-MF1	4	2100	360 (266)	–	–	–	–	11.0 (3.76)	–
	5	2100	360 (266)	–	–	–	–	9.95 (3.40)	–
	7	2600	360 (266)	–	–	–	–	9.01 (3.08)	–
	10	2600	220 (162)	–	–	–	–	8.44 (2.88)	–
SP 180S-MF1	4	1500	750 (553)	–	–	–	–	–	33.9 (11.6)
	5	1500	750 (553)	–	–	–	–	–	27.9 (9.53)
	7	2300	750 (553)	–	–	–	–	–	22.2 (7.59)
	10	2300	750 (553)	–	–	–	–	–	19.2 (6.56)
SP 210S-MF1	10	2000	1000 (738)	–	–	–	–	–	53.1 (18.1)

¹⁾ The limit values in the table apply for S1 continuous duty (ON time > 60 % or > 20 min) for a maximum gearbox temperature of 90 °C (194 °F).

Servomotors

Geared servomotors for SINAMICS S120

1FK7 motors with SP+ planetary gearbox

Selection and ordering data

Motor Type	Planetary gearbox two-stage		Available gear ratio $i =$					Motor speed, max. S3-60 %	Output torque, max. S3-60 %	Radial output shaft loading, max. ¹⁾	Axial output shaft loading, max. ¹⁾	
	Type	Torsional backlash arcmin	Gearbox weight, approx. kg (lb)	16	20	28	40	50	n_{G1} (n_1) rpm	M_{G2} (T_{2B}) Nm (lb _r -ft)	F_r (F_{2Rmax}) N (lb _f)	F_a (F_{2Amax}) N (lb _f)
1FK7022	SP 060S-MF2	≤ 6	2 (4.41)	✓	✓	✓	-	-	6000	40 (29.5)	2700 (607)	2400 (540)
1FK7032				✓	✓	-	-	-				
1FK7033				✓	✓	-	-	-				
1FK7022	SP 075S-MF2	≤ 6	3.6 (7.9)	-	-	-	✓	✓	6000	110 (81.1)	4000 (899)	3350 (753)
1FK7032				-	-	✓	✓	✓				
1FK7033				-	-	✓	✓	✓				
1FK7034				✓	✓	✓	-	-				
1FK7040				✓	✓	✓	-	-				
1FK7042				✓	✓	-	-	-				
1FK7043				✓	-	-	-	-				
1FK7034	SP 100S-MF2	≤ 5	7.9 (17.4)	-	-	-	✓	✓	4500	300 (221)	6300 (1416)	2400 (540)
1FK7040				-	-	-	✓	✓				
1FK7042				-	-	✓	✓	✓				
1FK7043				-	✓	✓	✓	✓				
1FK7044				✓	✓	✓	✓	-				
1FK7060				✓	✓	✓	-	-				
1FK7061				✓	✓	-	-	-				
1FK7062				✓	✓	-	-	-				
1FK7044	SP 140S-MF2	≤ 5	17 (37.5)	-	-	-	-	✓	4000	600 (442)	9450 (2124)	9870 (2219)
1FK7060				-	-	-	✓	✓				
1FK7061				-	-	✓	✓	✓				
1FK7062				-	-	✓	✓	-				
1FK7063				✓	✓	✓	-	-				
1FK7064				✓	✓	✓	-	-				
1FK7080				✓	✓	✓	✓	-				
1FK7081				✓	✓	✓	-	-				
1FK7083				✓	✓	-	-	-				
1FK7084				✓	-	-	-	-				
Gear shaft			Order code									
With fitted key			J12	J13	J15	J16	J17					
Without fitted key			J32	J33	J35	J36	J37					

Preconditions:

With the following motor versions, SP+ planetary gearboxes can be mounted:

- Plain motor shaft extension, shaft and flange accuracy tolerance N, without/with holding brake
- IP65 degree of protection and anthracite paint finish

SP+ planetary gearboxes can therefore only be ordered with these 1FK7 motors:

1FK7...-3B.71-1.G1
 1FK7...-3B.71-1.H1
 1FK7...-A..1-1.G5
 1FK7...-A..1-1.H5

When ordering a motor with gearbox, **-Z** should be added to the order number.

Example:

1FK7042 motor without holding brake
 with single-stage SP+ planetary gearbox
 with $i = 7$ and gear shaft without fitted key.
1FK7042-5AF71-1AG5-Z
J25

✓ Possible

- Not possible

¹⁾ Referred to the center of the output shaft at 100 rpm.

Servomotors

Geared servomotors for SINAMICS S120

1FK7 motors with SP+ planetary gearbox

Selection and ordering data

Motor Type	Planetary gearbox two-stage			Available gear ratio $i =$					Motor speed, max. S3-60 % n_{G1} (n_1) rpm	Output torque, max. S3-60 % M_{G2} (T_{2B}) Nm (lb _r -ft)	Radial output shaft loading, max. ¹⁾ F_r (F_{2Rmax}) N (lb _f)	Axial output shaft loading, max. ¹⁾ F_a (F_{2Amax}) N (lb _f)	
	Type	Torsional backlash arcmin	Gearbox weight, approx. kg (lb)	16	20	28	40	50					
1FK7062	SP 180S-MF2	≤ 5	36.4 (80.3)	-	-	-	-	✓	4000	1100 (811)	14700 (3305)	14150 (3181)	
1FK7063				-	-	-	✓	✓					
1FK7064				-	-	-	✓	✓					
1FK7080				-	-	-	-	-					✓
1FK7081				-	-	-	-	-					✓
1FK7083				-	-	✓	-	-					-
1FK7084				-	✓	✓	-	-					-
1FK7085				✓	✓	-	-	-					-
1FK7086				✓	✓	-	-	-					-
1FK7100				✓	✓	✓	-	-					-
1FK7101	✓	✓	-	-	-	-							
1FK7103	✓	-	-	-	-	-							
1FK7083	SP 210S-MF2	≤ 6	55 (121)	-	-	-	✓	✓	3500	2400 (1770) (2500 for $i = 20$)	21000 (4721)	30000 (6744)	
1FK7084				-	-	-	✓	✓					
1FK7085				-	-	✓	✓	-					-
1FK7086				-	-	✓	-	-					-
1FK7100				-	-	-	✓	✓					-
1FK7101				-	-	✓	-	-					-
1FK7103				-	✓	-	-	-					-
1FK7105				✓	✓	-	-	-					-
1FK7101	SP 240S-MF2	≤ 6	80.6 (178)	-	-	-	✓	✓	3500	4500 (3319) (4000 for $i = 40$ 4300 for $i = 50$)	30000 (6744)	33000 (7419)	
1FK7103				-	-	✓	✓	-					
1FK7105				-	-	✓	-	-					-
Gear shaft				Order code									
With fitted key				J12	J13	J15	J16	J17					
Without fitted key				J32	J33	J35	J36	J37					

Preconditions:

With the following motor versions, SP+ planetary gearboxes can be mounted:

- Plain motor shaft extension, shaft and flange accuracy tolerance N, without/with holding brake
- IP65 degree of protection and anthracite paint finish

SP+ planetary gearboxes can therefore only be ordered with these 1FK7 motors:

1FK7...-3B.71-1.G1
1FK7...-3B.71-1.H1
1FK7...-A..1-1.G5
1FK7...-A..1-1.H5

When ordering a motor with gearbox, **-Z** should be added to the order number.

Example:

1FK7042 motor without holding brake with single-stage SP+ planetary gearbox with $i = 7$ and gear shaft without fitted key.

1FK7042-5AF71-1AG5-**Z**
J25

✓ Possible

- Not possible

¹⁾ In reference to the output shaft center.

Servomotors

Geared servomotors for SINAMICS S120

1FK7 motors with SP+ planetary gearbox

Technical specifications

1FK7 motor with SP+ planetary gearbox

Two-stage Type	Gear ratio <i>i</i>	Motor speed	Output torque		Moments of inertia of gearbox (referred to the drive)					
		Continuous duty S1 ¹⁾	1FK702.		1FK703.	1FK704.	1FK706.	1FK708.	1FK710.	
		n_{N1} rpm	M_{N2} (T_{2N}) Nm (lb _f -ft)	J_1 kgcm ² (lb _f -in ²)	J_1 kgcm ² (lb _f -in ²)	J_1 kgcm ² (lb _f -in ²)	J_1 kgcm ² (lb _f -in ²)	J_1 kgcm ² (lb _f -in ²)	J_1 kgcm ² (lb _f -in ²)	J_1 kgcm ² (lb _f -in ²)
SP 060S-MF2	16	4400	26 (19.2)	0.08 (0.03)	0.17 (0.06)	–	–	–	–	
	20	4400	26 (19.2)	0.07 (0.024)	0.16 (0.05)	–	–	–	–	
	28	4400	26 (19.2)	0.06 (0.021)	–	–	–	–	–	
SP 075S-MF2	16	3500	75 (55.3)	–	0.23 (0.08)	0.55 (0.19)	–	–	–	
	20	3500	75 (55.3)	–	0.20 (0.07)	0.53 (0.18)	–	–	–	
	28	3500	75 (55.3)	–	0.18 (0.062)	0.50 (0.17)	–	–	–	
	40	3500	75 (55.3)	0.10 (0.03)	0.17 (0.058)	–	–	–	–	
	50	3800	75 (55.3)	0.10 (0.03)	0.16 (0.055)	–	–	–	–	
SP 100S-MF2	16	3100	180 (133)	–	–	0.81 (0.28)	2.18 (0.75)	–	–	
	20	3100	180 (133)	–	–	0.70 (0.24)	2.07 (0.71)	–	–	
	28	3100	180 (133)	–	–	0.60 (0.21)	1.97 (0.67)	–	–	
	40	3100	180 (133)	–	0.38 (0.13)	0.55 (0.188)	–	–	–	
	50	3500	175 (129)	–	0.38 (0.13)	0.54 (0.185)	–	–	–	
SP 140S-MF2	16	2900	360 (265)	–	–	–	3.19 (1.09)	10.3 (3.52)	–	
	20	2900	360 (265)	–	–	–	2.71 (0.93)	9.77 (3.34)	–	
	28	2900	360 (265)	–	–	–	2.34 (0.80)	9.41 (3.21)	–	
	40	2900	360 (265)	–	–	–	2.10 (0.72)	9.16 (3.13)	–	
	50	3200	360 (265)	–	–	1.39 (0.48)	2.08 (0.71)	–	–	
SP 180S-MF2	16	2700	750 (553)	–	–	–	–	12.4 (4.24)	13.5 (4.61)	
	20	2700	750 (553)	–	–	–	–	10.9 (3.73)	12.0 (4.10)	
	28	2700	750 (553)	–	–	–	–	9.48 (3.24)	10.6 (3.62)	
	40	2700	750 (553)	–	–	–	5.51 (1.88)	8.67 (2.96)	–	
	50	2900	750 (553)	–	–	–	5.45 (1.86)	8.61 (2.94)	–	
SP 210S-MF2	16	2500	1500 (1106)	–	–	–	–	–	34.5 (11.8)	
	20	2500	1500 (1106)	–	–	–	–	–	31.5 (10.8)	
	28	2500	1500 (1106)	–	–	–	–	30.0 (10.3)	30.0 (10.3)	
	40	2500	1500 (1106)	–	–	–	–	28.5 (9.74)	28.5 (9.74)	
	50	2500	1500 (1106)	–	–	–	–	28.3 (9.67)	28.3 (9.67)	
SP 240S-MF2	28	2500	2500 (1844)	–	–	–	–	–	30.5 (10.4)	
	40	2500	2500 (1844)	–	–	–	–	–	28.2 (9.64)	
	50	2500	2500 (1844)	–	–	–	–	–	27.9 (9.53)	

¹⁾ The limit values in the table apply for S1 continuous duty (ON time > 60 % or > 20 min) for a maximum gearbox temperature of 90 °C (194 °F).

Servomotors

Geared servomotors for SINAMICS S120

1FK7 motors with LP+ planetary gearbox

Overview



1FK7 motor with mounted series LP+ planetary gearbox

1FK7 motors can easily be combined with planetary gearboxes to form compact coaxial drive units. The gearboxes are flanged directly to the drive end of the motors.

When selecting the gearbox, ensure that its maximum permissible input speed is not exceeded by the maximum speed of the motor. In the case of high operating frequencies, allowance must be made for the factor f_2 (see Configuration Manual for 1FK7 synchronous motors). The frictional losses of the gearbox must always be taken into account.

The gearboxes are only available in non-balanced design and with fitted key.

Benefits

- High efficiency, single-stage: > 97 %
- Minimum torsional backlash, single-stage: ≤ 12 arcmin
- Power transmission from the central sun wheel via planet wheels
- No shaft deflections in the planet wheel set due to symmetrical force distribution
- The gearboxes are connected to the motor shaft via an integrated clamping hub. A plain motor shaft extension is necessary for this purpose. Shaft and flange accuracy tolerance N in accordance with DIN 42955 and vibration magnitude grade A in accordance with EN 60034-14 are sufficient. The motor flange is adapted by means of adapter plates.
- Output shaft of gearbox exactly coaxial with the motor
- The gearboxes are enclosed (seal between gearbox and motor) and filled with grease in the factory. They are lubricated and sealed for their service life. The gearboxes are suitable for all mounting positions.
- Degree of protection of gearbox: IP64
- Small dimensions
- Low weight

Integration

1FK702 to 1FK710 motors can be supplied ex works (Siemens AG) complete with flange-mounted planetary gearbox.

The gearboxes assigned to the individual motors and gear ratios i available for these motor/gearbox combinations are listed in the subsequent selection table. When making a selection, note the maximum permissible input speed of the gearbox (this is the same as the maximum motor speed).

The motor/gearbox combinations listed in the selection table are mainly intended for cycle operation S3-60 % (ON time ≤ 60 % and ≤ 20 min). Reduced maximum motor speeds and output torques apply for use in S1 continuous duty (ON time > 60 % or > 20 min). The gearbox temperature may not exceed 90 °C (194 °F).

Follow the instructions contained in the Configuration Manual for 1FK7 synchronous motors when assigning gearboxes to the motor.

Servomotors

Geared servomotors for SINAMICS S120

1FK7 motors with LP+ planetary gearbox

Selection and ordering data

Motor Type	Planetary gearbox LP+ single-stage Torsional backlash ≤ 12 arcmin		Available gear ratio $i =$		Input speed, max. S3-60 %	Output torque, max. S3-60 %		Output shaft radial force, max. ¹⁾	Gearbox moment of inertia
	Type	Gearbox weight, approx. kg (lb)	5	10	n_{G1} rpm	M_{G2} at $i = 5$ Nm (lb _r -ft)	M_{G2} at $i = 10$ Nm (lb _r -ft)	F_r N (lb _f)	J_G at $i = 5/10$ 10^{-4} kgm ² (10^{-3} lb _f -in ²)
1FK7022	LP 050-MO1	0.75 (1.65)	✓	–	8000	12 (8.9)	11 (8.1)	650 (146)	0.055 (0.05)
1FK7022	LP 070-MO1	2 (4.41)	–	✓	6000	35 (25.8)	32 (23.6)	1450 (326)	0.28 (0.25)
1FK7032			✓	✓					
1FK7033			✓	✓					
1FK7034			✓	✓					
1FK7040	LP 090-MO1	4 (8.82)	✓	✓	6000	90 (66.4)	80 (59.0)	1900 (427)	1.77 (1.57)
1FK7042			✓	✓					
1FK7043			✓	✓					
1FK7044			✓	✓					
1FK7060	LP 120-MO1	8.6 (19.0)	✓	✓	4800	220 (162)	200 (148)	4000 (899)	5.42 (4.80)
1FK7061			✓	✓					
1FK7062			✓	✓					
1FK7063			✓	✓					
1FK7064			✓	–					
1FK7080	LP 155-MO1	17 (37.5)	✓	✓	3600	450 (332)	350 (258)	6000 (1349)	25.7 (22.8)
1FK7081			✓	✓					
1FK7083			✓	✓					
1FK7084			✓	✓					
1FK7085			✓	✓					
1FK7086			✓	✓					
1FK7100			✓	✓					
1FK7101	✓	–							
1FK7103	✓	–							
1FK7105	✓	–							
Gear shaft With fitted key			Order code V40	V42					

Preconditions:

With the following motor versions, LP+ planetary gearboxes can be mounted:

- Plain motor shaft extension, shaft and flange accuracy tolerance N, without/with holding brake
- IP64 degree of protection and anthracite paint finish

LP+ planetary gearbox can therefore only be ordered with these 1FK7 motors:

1FK7...-3B.71-1.G0
1FK7...-3B.71-1.H0
1FK7...-A..1-1.G3
1FK7...-A..1-1.H3

When ordering a motor with gearbox, **-Z** should be added to the order number.

Example:

1FK7042 motor with holding brake with single-stage LP+ planetary gearbox with $i = 5$ and gear shaft with fitted key.
1FK7042-3BK71-1AH0-**Z**

V40

✓ Possible

– Not possible

¹⁾ Referred to the center of the output shaft at 100 rpm.

Continuous duty

Continuous duty is permissible at the rated speed and rated torque. The gearbox temperature may not exceed 90 °C (194 °F).

Planetary gearbox LP+ single-stage Torsional backlash ≤ 12 arcmin	Rated input speed	Rated output torque	
Type	n_{G1} rpm	M_{G2} at $i = 5$ Nm (lb _r -ft)	M_{G2} at $i = 10$ Nm (lb _r -ft)
LP 050-MO1	4000	5.7 (4.2)	–
LP 070-MO1	3700	18 (13.3)	16.5 (12.2)
LP 090-MO1	3400	45 (33.2)	40 (29.5)
LP 120-MO1	2600	110 (81.1)	100 (73.8)
LP 155-MO1	2000	320 (236)	190 (140)

Servomotors

Geared servomotors for SINAMICS S120

1FK7-DYA compact geared motors

Overview



1FK7-DYA compact geared motor

The 1FK7-DYA compact geared motor combines electrical and mechanical components in the smallest space possible. This mechatronic unit consists of a permanent-magnet 1FK7 synchronous motor and a directly mounted single-stage planetary gearbox.

The 1FK7-DYA compact geared motors with IP64 degree of protection are designed for operation without external cooling and the heat is dissipated over the motor surface. The integrated planetary gearboxes have high maximum torques and permit high radial and axial forces at the shaft extension.

Benefits

- Space-saving installation due to the high power density of the motor and integration of the planetary gearbox directly into the motor end shield. Mounting to the machine is greatly simplified by this and the logistics are reduced to a minimum.
- Mounting in construction types IM B5 and IMB14 is possible
- Highly dynamic due to lower motor moment of inertia; this means shorter cycle times.
- Maintenance-free
- Suitable for S1 continuous duty
- High positioning accuracy thanks to low mechanical torsional backlash of < 8 arcmin
- Mechanical compatibility with regard to IM B14 flange and shaft extension for the LP+ planetary gearbox
- Power and signals are connected via a connector

Application

In general mechanical engineering, any place where coaxial drive units are used, e.g. in

- Packaging machines
- Wood, glass and ceramic processing machines
- Plastic, injection molding and foil stretching machines
- Handling systems
- Machine tools
- All kinds of auxiliary axes

Integration

1FK7-DYA compact geared motors can be combined with the SINAMICS S120 drive system to create a powerful system with high functionality. The integrated encoder system for speed and position control can be selected depending on the application.

Servomotors

Geared servomotors for SINAMICS S120

1FK7-DYA compact geared motors

Technical specifications

1FK7-DYA compact geared motor	
Type of motor	Permanent-magnet synchronous motor
Magnet material	Rare-earth magnet material
Cooling	Natural cooling
Temperature monitoring	KTY84 temperature sensor in stator winding
Insulation of the stator winding in accordance with EN 60034-1 (IEC 60034-1)	Temperature class 155 (F) for a winding temperature rise of $\Delta T = 100 \text{ K}$ at an ambient temperature of 40 °C (104 °F)
Type of construction in accordance with EN 60034-7 (IEC 60034-7)	IM B5 (IM V1, IM V3) IM B14
Degree of protection in accordance with EN 60034-5 (IEC 60034-5)	IP64
Shaft extension on the drive end (DE) in accordance with DIN 748-3 (IEC 60072-1)	With fitted key
Shaft and flange accuracy in accordance with DIN 42955 (IEC 60072-1)¹⁾	Tolerance N
Vibration magnitude in accordance with EN 60034-14 (IEC 60034-14)	Grade A is maintained up to rated speed
Max. sound pressure level L_{pA} (1 m) in accordance with EN ISO 1680	72 dB 75 dB 80 dB 82 dB
Connection	Connectors for signals and power can be rotated 270°
Paint finish	Anthracite RAL 7016
2nd rating plate	Attached in the NDE cover
3rd rating plate	Enclosed separately
Holding brake	Without/with
Approvals, according to	cURus

Built-in encoder systems without DRIVE-CLiQ interface

Incremental encoder

IC2048S/R encoder Incremental encoder sin/cos $1 V_{pp}$ 2048 S/R with C and D tracks

Absolute encoder

AM2048S/R encoder Absolute encoder 2048 S/R, 4096 revolutions, multi-turn

AM512S/R encoder Absolute encoder 512 S/R, 4096 revolutions, multi-turn

AM32S/R encoder Absolute encoder 32 S/R, 4096 revolutions, multi-turn

AM16S/R encoder Absolute encoder 16 S/R, 4096 revolutions, multi-turn

Resolver

Multi-pole resolver Multi-pole resolver (number of pole pairs corresponds to number of pole pairs of the motor)

2-pole resolver 2-pole resolver

Built-in encoder systems with DRIVE-CLiQ interface

Incremental encoder

IC22DQ encoder Incremental encoder 22 bit (resolution 4194304, internal 2048 S/R) + commutation position 11 bit

Absolute encoder

AM22DQ encoder Absolute encoder 22 bit (resolution 4194304, internal 2048 S/R) + 12 bit multi-turn (traversing range 4096 revolutions)

AM20DQ encoder Absolute encoder 20 bit (resolution 1048576, internal 512 S/R) + 12 bit multi-turn (traversing range 4096 revolutions)

AM16DQ encoder Absolute encoder 16 bit (resolution 65536, internal 32 S/R) + 12 bit multi-turn (traversing range 4096 revolutions)

AM15DQ encoder Absolute encoder 15 bit (resolution 32768, internal 16 S/R) + 12 bit multi-turn (traversing range 4096 revolutions)

Resolver

R15DQ resolver Resolver 15 bit (resolution 32768, internal, multi-pole)

R14DQ resolver Resolver 14 bit (resolution 16384, internal, 2-pole)

S/R=signals/revolution

¹⁾ Shaft extension run-out, concentricity of centering ring and shaft, and perpendicularity of flange to shaft.

Servomotors

Geared servomotors for SINAMICS S120

1FK7-DYA compact geared motors Natural cooling

Selection and ordering data

Rated speed	Rated power	Speed, max.	Torque, max.	Static torque	Rated torque ¹⁾	Available gear ratio	1FK7-DYA compact geared motors		Number of pole pairs	Moment of inertia of rotor ²⁾		
$n_{2 \text{ rated}}$	P_2	$n_{2 \text{ max}}$	$M_{2 \text{ max}}$	M_{20}	$M_{2 \text{ rated}}$	i	Order No.	Order code	p	J	J	
rpm	kW (HP)	rpm	Nm (lb _f -ft)	Nm (lb _f -ft)	Nm (lb _f -ft)					10^{-4} kgm ² (10 ⁻³ lb _f -in-s ²)	10^{-4} kgm ² (10 ⁻³ lb _f -in-s ²)	
Natural cooling												
370	0.37 (0.50)	600	32 (23.6)	11 (8.1)	9.5 (7.0)	10	1FK7032-5AK71-1	3-Z A03	3	0.75 (0.66)	0.83 (0.73)	
740	0.5 (0.67)	1200	32 (23.6)	7.5 (5.5)	6.5 (4.8)	5	1FK7034-5AK71-1	3-Z A00	3	1.04 (0.92)	1.12 (0.99)	
340	0.45 (0.60)	600	49 (36.1)	15 (11.1)	12.5 (9.2)	10	1FK7040-5AK71-1	3-Z A13	4	2.3 (2.04)	3 (2.66)	
680	0.71 (0.95)	1200	51 (37.6)	13 (9.6)	10 (7.4)	5	1FK7042-5AK71-1	3-Z A10	4	3.6 (3.19)	4.3 (3.81)	
260	1.25 (1.68)	480	175 (129)	57 (42)	46 (33.9)	10	1FK7060-5AH71-1	3-Z A73	4	10.3 (9.12)	12.5 (11.1)	
520	1.74 (2.33)	960	170 (125)	51 (37.6)	32 (23.6)	5	1FK7063-5AH71-1	3-Z A70	4	17.4 (15.4)	19.6 (17.4)	
200	1.47 (1.97)	360	242 (179)	76 (56.1)	70 (51.6)	10	1FK7080-5AH71-1	3-Z A83	4	28.7 (25.4)	31.8 (28.2)	
400	1.88 (2.52)	720	233 (172)	68 (50.2)	45 (33.2)	5	1FK7083-5AH71-1	3-Z A80	4	41 (36.3)	49.6 (43.9)	
Encoder systems for motors without DRIVE-CLiQ interface:		IC2048S/R encoder						A				
		AM2048S/R encoder (<u>not</u> for 1FK703)						E				
		AM512S/R encoder (<u>only</u> for 1FK703)						H				
		AM32S/R encoder (<u>not</u> for 1FK703)						G				
		AM16S/R encoder (<u>only</u> for 1FK703)						J				
		Multi-pole resolver						S				
		2-pole resolver						T				
Encoder systems for motors with DRIVE-CLiQ interface:		IC22DQ encoder						D				
		AM22DQ encoder						F				
		AM20DQ encoder						L				
		AM16DQ encoder						K				
		AM15DQ encoder						V				
		R15DQ resolver						U				
		R14DQ resolver						P				
Shaft extension:		Shaft and flange accuracy:				Holding brake:						
Fitted key and keyway		Tolerance N				Without						
Fitted key and keyway		Tolerance N				With						
Degree of protection:		IP64, anthracite paint finish										3

4

Servomotors

Geared servomotors for SINAMICS S120

1FK7-DYA compact geared motors
Natural cooling

Motor type (repeated)	Weight without brake	with brake	Static current I_0 at M_0 $\Delta T = 100$ K	Maxi- mum current I_{max}	SINAMICS S120 Motor Module		Power cable with complete shield		
	m	m			Rated out- put current ³⁾	Booksiz e format For additional versions and components, see chapter SINAMICS S120 drive system Order No.	Motor connection (and brake connection) via power connector	Power con- nector	Cable cross- section ⁴⁾
	kg (lb)	kg (lb)	A	A	A		Size	mm ²	Order No.
1FK7032-5AK71-...	4.11 (9.06)	4.47 (9.86)	1.7	5	3	6SL312-TE13-0AA3	1	4 × 1.5	6FX 002-5S01-...
1FK7034-5AK71-...	5.01 (11.1)	5.37 (11.8)	1.9	7.9	3	6SL312-TE13-0AA3	1	4 × 1.5	6FX 002-5S01-...
1FK7040-5AK71-...	6.60 (14.6)	7.61 (16.8)	2.3	7.4	3	6SL312-TE13-0AA3	1	4 × 1.5	6FX 002-5S01-...
1FK7042-5AK71-...	7.91 (17.4)	8.62 (19.0)	4.4	14.9	5	6SL312-TE15-0AA3	1	4 × 1.5	6FX 002-5S01-...
1FK7060-5AH71-...	13.9 (30.7)	15 (33.1)	6.2	19	9	6SL312-TE21-0AA3	1	4 × 1.5	6FX 002-5S01-...
1FK7063-5AH71-...	17.6 (38.8)	19 (41.9)	12	41	18	6SL312-TE21-8AA3	1	4 × 1.5	6FX 002-5S01-...
1FK7080-5AH71-...	23.4 (51.6)	24.6 (54.2)	7.4	24	9	6SL312-TE21-0AA3	1	4 × 1.5	6FX 002-5S01-...
1FK7083-5AH71-...	28.6 (63.1)	31.2 (68.8)	15	48	18	6SL312-TE21-8AA3	1	4 × 1.5	6FX 002-5S01-...

Cooling:

Internal air cooling **0**
External air cooling **1**

Motor Module:

Single Motor Module **1**
Double Motor Module

Power cable:

MOTION-CONNECT 800 **8**
MOTION-CONNECT 500 **5**

Without brake cores **C**
With brake cores **D**

Length code **....**

Information about the cables
can be found in chapter
Connection system MOTION-CONNECT.

¹⁾ If the absolute encoder is used, $M_{2 rated}$ is reduced by 10 %.

²⁾ In reference to the internal motor shaft.

³⁾ With default setting of the pulse frequency.

⁴⁾ The current carrying capacity of the power cables complies with EN 60204-1 for installation type C, for continuous duty at an ambient air temperature of 40 °C (104 °F).

Servomotors

Geared servomotors for SINAMICS S120

1FK7 geared servomotors

Overview



1FK7 bevel geared motor/1FK7 offset-shaft geared motors



1FK7 worm geared motors/1FK7 helical geared motors

The 1FK7 geared servomotors comprise the 1FK7 synchronous motors described above and the directly mounted helical and bevel gears.

The 1FK7 geared servomotors are pre-assembled as a complete unit and supplied with a gearbox filled with oil.

The type range comprises helical geared motors with 9 gearbox sizes, offset-shaft geared motors with 5 gearbox sizes, bevel geared motors with 8 gearbox sizes and worm geared motors with 5 gearbox sizes. A wide range of mechanical mounting methods can be implemented with the numerous options.

1FK7 geared servomotors are designed for operation without external cooling and the heat is dissipated through the motor surface and the gearbox mounting surface.

1FK7 geared servomotors can be combined with the SINAMICS S120 drive system to create a powerful system with high functionality. Integrated encoder systems for speed and position control can be selected depending on the application just as for 1FK7 synchronous motors.

Benefits

- Extremely compact design as a result of the direct mounting (because there is no coupling cage between the motor and gearbox)
- Maintenance-free and lubricated for life (exception, worm gearing)
- High efficiency
- Low torsional backlash
- Low running noise due to the helical gearing
- Service-life maintenance-free gearing (exception: worm gearing)
- Suitable for cyclic operation with alternating load and continuous duty
- Low-cost solution when compared to planetary geared motors

Application

1FK7 geared servomotors are ideally suited for applications in general machine construction for basic positioning tasks and auxiliary drives with servo quality that continually operate, for example in:

- Packaging machines
- High-bay racking units
- Wood, glass and ceramic processing machines
- Beverage filling plants
- Conveyor belts

Other Siemens geared motors can be found at www.siemens.com/sgmdesigner

Technical specifications

1FK7 helical geared motor	
Nominal ratio i_{nom}	3.8 ... 70
Rated output torque M_2	3.6 ... 1737 Nm (2.7 ... 1281 lb _f -ft)
Acceleration torque M_{2max}	19 ... 4140 Nm (14 ... 3054 lb _f -ft)
Torsional backlash	10 ... 20 arcmin
Efficiency	94 ... 96 %
Mechanical options	Solid shaft with fitted key, flange, mounting feet, tapped hole group

1FK7 offset-shaft geared motor	
Nominal ratio i_{nom}	4.3 ... 35
Rated output torque M_2	4 ... 587 Nm (3 ... 433 lb _f -ft)
Acceleration torque M_{2max}	24 ... 1100 Nm (2.7 ... 811 lb _f -ft)
Torsional backlash	10 ... 11 arcmin
Efficiency	94 ... 96 %
Mechanical options	Solid shaft, hollow shaft with fitted key, hollow shaft with clamping element/shrink disk, flange, mounting feet, tapped hole group

1FK7 bevel geared motor	
Nominal ratio i_{nom}	4 ... 76
Rated output torque M_2	3.8 ... 1626 Nm (2.8 ... 1199 lb _f -ft)
Acceleration torque M_{2max}	22 ... 4650 Nm (16 ... 3430 lb _f -ft)
Torsional backlash	10 ... 12 arcmin
Efficiency	94 ... 96 %
Mechanical options	Solid shaft, hollow shaft with fitted key, hollow shaft with clamping element/shrink disk, flange, mounting feet, tapped hole group, torque bracket

1FK7 worm geared motor	
Nominal ratio i_{nom}	9.2 ... 70
Rated output torque M_2	8.5 ... 399 Nm (6.3 ... 294 lb _f -ft)
Acceleration torque M_{2max}	43 ... 791 Nm (32 ... 583 lb _f -ft)
Torsional backlash	Depending on the gearbox size and gear ratio
Mechanical options	Solid shaft, hollow shaft with fitted key, hollow shaft with clamping element/shrink disk, flange, mounting feet, tapped hole group, torque bracket

Explanation of the designations in the selection tables

n_2	Gearbox output speed referred to the input speed of the motor of $n_1 = 3000$ rpm for a horizontal gear shaft output
i_{nom}	Nominal gear ratio (approximate value as decimal number)
i_{exact}	Exact gear ratio (specified as a fraction for parameter entry in the drive converter)
f_B	Gearbox overload factor (quotient between the max. permissible acceleration torque and static torque of the motor and ratio)

Built-in encoder systems without DRIVE-CLiQ interface

Incremental encoder	
IC2048S/R encoder	Incremental encoder sin/cos 1 V _{pp} 2048 S/R with C and D tracks
Absolute encoder	
AM2048S/R encoder	Absolute encoder 2048 S/R, 4096 revolutions, multi-turn
AM512S/R encoder	Absolute encoder 512 S/R, 4096 revolutions, multi-turn
AM32S/R encoder	Absolute encoder 32 S/R, 4096 revolutions, multi-turn
AM16S/R encoder	Absolute encoder 16 S/R, 4096 revolutions, multi-turn
Resolver	
Multi-pole resolver	Multi-pole resolver (number of pole pairs corresponds to number of pole pairs of the motor)
2-pole resolver	2-pole resolver

Built-in encoder systems with DRIVE-CLiQ interface

Incremental encoder	
IC22DQ encoder	Incremental encoder 22 bit (resolution 4194304, internal 2048 S/R) + commutation position 11 bit
Absolute encoder	
AM22DQ encoder	Absolute encoder 22 bit (resolution 4194304, internal 2048 S/R) + 12 bit multi-turn (traversing range 4096 revolutions)
AM20DQ encoder	Absolute encoder 20 bit (resolution 1048576, internal 512 S/R) + 12 bit multi-turn (traversing range 4096 revolutions)
AM16DQ encoder	Absolute encoder 16 bit (resolution 65536, internal 32 S/R) + 12 bit multi-turn (traversing range 4096 revolutions)
AM15DQ encoder	Absolute encoder 15 bit (resolution 32768, internal 16 S/R) + 12 bit multi-turn (traversing range 4096 revolutions)
Resolver	
R15DQ resolver	Resolver 15 bit (resolution 32768, internal, multi-pole)
R14DQ resolver	Resolver 14 bit (resolution 16384, internal, 2-pole)

S/R=signals/revolution

Servomotors

Geared servomotors for SINAMICS S120

1FK7 helical geared motors

Selection and ordering data

Power at duty type S3-60 %	Output speed at the gear shaft	Rated output torque gearbox at duty type S3-60 %	Acceleration torque, max. gearbox	Nominal ratio	Exact ratio	Cantilever force, perm., gear shaft extension	Overload factor
P_2	n_2	M_2	M_{2max}	i_{nom}	i_{exact}	F_{Tperm}	f_B
kW (HP)	rpm	Nm (lb _f -ft)	Nm (lb _f -ft)			N (lb _f)	
Natural cooling – SH 36/SH 48/SH 63							
0.30 (0.40)	782	3.63 (2.68)	19 (14.0)	3.8	441/115	560 (126)	4.2
	476	5.96 (4.40)	29 (21.4)	6.3	2035/323	660 (148)	3.9
	291	9.74 (7.18)	51 (37.6)	10.5	1421/138	778 (175)	4.2
	192	14.8 (10.9)	72 (53.1)	15.5	1595/102	894 (201)	3.9
	129	22 (16.2)	65 (47.9)	23	325/14	1020 (229)	2.4
	86	33.1 (24.4)	65 (47.9)	35	1261/36	1170 (263)	1.6
	64	44.3 (32.7)	65 (47.9)	47	7865/168	1289 (290)	1.2
	43	66.6 (49.1)	138 (102)	70	775/11	2099 (472)	1.7
0.41 (0.55)	782	5.02 (3.70)	36 (26.6)	3.8	441/115	560 (126)	6.0
	476	8.25 (6.10)	55 (40.6)	6.3	2035/323	660 (148)	5.6
	291	13.5 (10.0)	72 (53.1)	10.5	1421/138	778 (175)	4.5
	192	20.5 (15.1)	72 (53.1)	15.5	1595/102	894 (201)	3.0
	128	30.8 (22.7)	138 (102)	24	1035/44	1456 (327)	3.8
	129	30.4 (22.4)	65 (47.9)	23	325/14	1020 (229)	1.8
	86	45.9 (33.9)	138 (102)	35	2700/77	1663 (374)	2.5
	86	45.9 (33.9)	65 (47.9)	35	1261/36	1170 (263)	1.2
	64	61.4 (45.3)	138 (102)	47	516/11	1833 (412)	1.9
	0.79 (1.06)	782	9.67 (7.10)	36 (26.6)	3.8	441/115	560 (126)
476		15.9 (11.7)	55 (40.6)	6.3	2035/323	660 (148)	3.0
	291	26 (19.2)	72 (53.1)	10.5	1421/138	778 (175)	2.4
	191	39.6 (29.2)	138 (102)	15.5	377/24	1273 (286)	3.0
	192	39.4 (29.1)	72 (53.1)	15.5	1595/102	894 (201)	1.6
	128	59.3 (43.7)	138 (102)	24	1035/44	1456 (327)	2.0
	86	88.4 (65.2)	138 (102)	35	2700/77	1663 (374)	1.4
	64	118 (87.0)	138 (102)	47	516/11	1833 (412)	1.0
1.43 (1.92)	782	17.5 (12.9)	50 (36.9)	3.8	441/115	560 (126)	2.2
	476	28.7 (21.2)	59 (43.5)	6.3	2035/323	660 (148)	1.6
	511	26.8 (19.8)	102 (75.2)	5.9	47/8	917 (206)	3.0
	291	46.9 (34.6)	72 (53.1)	10.5	1421/138	778 (175)	1.2
	289	47.3 (34.9)	138 (102)	10.5	841/81	1109 (249)	2.3
	191	71.6 (52.8)	138 (102)	15.5	377/24	1273 (286)	1.5
	196	69.7 (51.4)	230 (170)	15.5	703/46	1775 (399)	2.6
	128	107 (78.9)	138 (102)	25	1035/44	1456 (327)	1.0
	128	107 (78.9)	350 (258)	24	845/36	3045 (685)	2.6

Servomotors

Geared servomotors for SINAMICS S120

1FK7 helical geared motors

Gearbox size	Motor shaft height	1FK7 helical geared motors				Gearbox weight, approx. kg (lb)
		Order No.	Order codes	Type/gear shaft extension	Type of construction/ mounting position/ connector mounting position	
C002	36	1FK7032-5AK71-1 ■■■ 5-Z	D01	G . .	H . .	8.6 (19.0)
C002	36	1FK7032-5AK71-1 ■■■ 5-Z	D02	G . .	H . .	8.6 (19.0)
C002	36	1FK7032-5AK71-1 ■■■ 5-Z	D03	G . .	H . .	8.6 (19.0)
C002	36	1FK7032-5AK71-1 ■■■ 5-Z	D04	G . .	H . .	8.6 (19.0)
C002	36	1FK7032-5AK71-1 ■■■ 5-Z	D05	G . .	H . .	8.6 (19.0)
C002	36	1FK7032-5AK71-1 ■■■ 5-Z	D06	G . .	H . .	8.6 (19.0)
C002	36	1FK7032-5AK71-1 ■■■ 5-Z	D07	G . .	H . .	8.6 (19.0)
C102	36	1FK7032-5AK71-1 ■■■ 5-Z	D18	G . .	H . .	13.5 (29.8)
C002	48	1FK7040-5AK71-1 ■■■ 5-Z	D01	G . .	H . .	9.4 (20.7)
C002	48	1FK7040-5AK71-1 ■■■ 5-Z	D02	G . .	H . .	9.4 (20.7)
C002	48	1FK7040-5AK71-1 ■■■ 5-Z	D03	G . .	H . .	9.4 (20.7)
C002	48	1FK7040-5AK71-1 ■■■ 5-Z	D04	G . .	H . .	9.4 (20.7)
C102	48	1FK7040-5AK71-1 ■■■ 5-Z	D15	G . .	H . .	14.3 (31.5)
C002	48	1FK7040-5AK71-1 ■■■ 5-Z	D05	G . .	H . .	9.4 (20.7)
C102	48	1FK7040-5AK71-1 ■■■ 5-Z	D16	G . .	H . .	14.3 (31.5)
C002	48	1FK7040-5AK71-1 ■■■ 5-Z	D06	G . .	H . .	9.4 (20.7)
C102	48	1FK7040-5AK71-1 ■■■ 5-Z	D17	G . .	H . .	14.3 (31.5)
C002	48	1FK7042-5AF71-1 ■■■ 5-Z	D01	G . .	H . .	10.7 (23.6)
C002	48	1FK7042-5AF71-1 ■■■ 5-Z	D02	G . .	H . .	10.7 (23.6)
C002	48	1FK7042-5AF71-1 ■■■ 5-Z	D03	G . .	H . .	10.7 (23.6)
C102	48	1FK7042-5AF71-1 ■■■ 5-Z	D14	G . .	H . .	15.6 (34.4)
C002	48	1FK7042-5AF71-1 ■■■ 5-Z	D04	G . .	H . .	10.7 (23.6)
C102	48	1FK7042-5AF71-1 ■■■ 5-Z	D15	G . .	H . .	15.6 (34.4)
C102	48	1FK7042-5AF71-1 ■■■ 5-Z	D16	G . .	H . .	15.6 (34.4)
C102	48	1FK7042-5AF71-1 ■■■ 5-Z	D17	G . .	H . .	15.6 (34.4)
C002	63	1FK7060-5AF71-1 ■■■ 5-Z	D01	G . .	H . .	13.4 (29.6)
C002	63	1FK7060-5AF71-1 ■■■ 5-Z	D02	G . .	H . .	13.4 (29.6)
C102	63	1FK7060-5AF71-1 ■■■ 5-Z	D12	G . .	H . .	18.3 (40.4)
C002	63	1FK7060-5AF71-1 ■■■ 5-Z	D03	G . .	H . .	13.4 (29.6)
C102	63	1FK7060-5AF71-1 ■■■ 5-Z	D13	G . .	H . .	18.3 (40.4)
C102	63	1FK7060-5AF71-1 ■■■ 5-Z	D14	G . .	H . .	18.3 (40.4)
C202	63	1FK7060-5AF71-1 ■■■ 5-Z	D24	G . .	H . .	22.3 (49.2)
C102	63	1FK7060-5AF71-1 ■■■ 5-Z	D15	G . .	H . .	18.3 (40.4)
C302	63	1FK7060-5AF71-1 ■■■ 5-Z	D35	G . .	H . .	27.4 (60.4)
Encoder systems for motors without DRIVE-CLiQ interface:	IC2048S/R encoder AM2048S/R encoder (from shaft height 48) AM512S/R encoder (shaft height 36 only) AM32S/R encoder (from shaft height 48) AM16S/R encoder (shaft height 36 only) Multi-pole resolver 2-pole resolver	A E H G J S T				
Encoder systems for motors with DRIVE-CLiQ interface:	IC22DQ encoder AM22DQ encoder (from shaft height 48) AM20DQ encoder (shaft height 36 only) AM16DQ encoder (from shaft height 48) AM15DQ encoder (shaft height 36 only) R15DQ resolver R14DQ resolver	D F L K V U P				
Holding brake:	Motor without holding brake Motor with holding brake	U V				

Order codes for type/
gear shaft extension and type of
construction/mounting position/
connector mounting position,
see page 4/86.

Servomotors

Geared servomotors for SINAMICS S120

1FK7 helical geared motors

Selection and ordering data

Power at duty type S3-60 %	Output speed at the gear shaft	Rated output torque gearbox at duty type S3-60 %	Acceleration torque, max. gearbox	Nominal ratio	Exact ratio	Cantilever force, perm., gear shaft extension	Overload factor
P_2	n_2	M_2	M_{2max}	i_{nom}	i_{exact}	F_{Tperm}	f_B
kW (HP)	rpm	Nm (lb _F -ft)	Nm (lb _F -ft)			N (lb _F)	
Natural cooling – SH 63/SH 80							
1.42 (1.90)	85	160 (118)	230 (170)	35	1372/39	2343 (527)	1.1
1.43 (1.92)	86	159 (117)	550 (406)	35	975/28	5961 (1340)	2.7
	60	227 (167)	400 (295)	50	2736/55	3911 (879)	1.4
1.44 (1.93)	60	229 (169)	600 (443)	50	1305/26	6734 (1514)	2.1
	43	319 (235)	550 (406)	70	559/8	7519 (1690)	1.4
	43	319 (235)	850 (627)	70	10075/144	9229 (2075)	2.1
2.23 (2.99)	782	27.2 (20.1)	50 (36.9)	3.8	441/115	560 (126)	1.2
	511	41.6 (30.7)	102 (75.2)	5.9	47/8	917 (206)	1.6
2.22 (2.98)	289	73.5 (54.2)	138 (102)	10.5	841/81	1109 (249)	1.2
	196	108 (79.7)	230 (170)	15.5	703/46	1775 (399)	1.4
	128	166 (122)	350 (258)	23	845/36	3045 (685)	1.4
	86	247 (182)	550 (406)	35	975/28	5961 (1340)	1.5
	2.23 (2.99)	60	355 (262)	600 (443)	50	1305/26	6734 (1514)
	43	495 (365)	850 (627)	70	10075/144	9229 (2075)	1.1
2.07 (2.78)	773	25.6 (18.9)	101 (74.5)	3.9	1363/351	799 (180)	3.3
2.08 (2.79)	511	38.8 (28.6)	115 (84.8)	5.9	47/8	917 (206)	2.5
2.07 (2.78)	289	68.5 (50.5)	138 (102)	10.5	847/81	1109 (249)	1.7
	196	101 (74.5)	230 (170)	15.5	703/46	1775 (399)	1.9
2.08 (2.79)	191	104 (76.7)	138 (102)	15.5	377/24	1273 (286)	1.1
	128	155 (114)	350 (258)	23	845/36	3045 (685)	1.9
2.07 (2.78)	127	156 (115)	230 (170)	24	637/27	2051 (461)	1.3
	86	230 (170)	550 (406)	35	975/28	5961 (1340)	2.0
2.08 (2.79)	86	231 (170)	350 (258)	35	1261/36	3479 (782)	1.3
2.07 (2.78)	60	329 (243)	920 (679)	50	1943/39	8241 (1853)	2.4
2.09 (2.80)	44	454 (335)	1380 (1018)	69	620/9	12344 (2775)	2.6
3.20 (4.29)	773	39.5 (29.1)	101 (74.5)	3.9	1363/351	799 (180)	1.7
	772	39.6 (29.2)	154 (114)	3.9	486/125	1125 (253)	2.5
	511	59.8 (44.1)	115 (84.8)	5.9	47/8	917 (206)	1.3
	518	59.0 (43.5)	176 (130)	5.8	666/115	1284 (289)	2.0
	320	95.6 (70.5)	230 (170)	9.4	2450/261	1509 (339)	1.6
	322	94.8 (69.9)	350 (258)	9.3	3575/384	2237 (503)	2.4
3.19 (4.28)	193	158 (117)	400 (295)	15.5	544/35	2654 (597)	1.7
3.18 (4.26)	190	160 (118)	600 (443)	16	63/4	4576 (1029)	2.5
3.19 (4.28)	128	238 (176)	550 (406)	23	1495/64	5219 (1173)	1.5
	128	238 (176)	850 (627)	23	1495/64	6402 (1439)	2.3
3.20 (4.29)	86	355 (262)	550 (406)	35	975/28	5961 (1340)	1.0
	86	355 (262)	1380 (1018)	35	1360/39	9838 (2212)	2.6
3.19 (4.28)	60	507 (374)	920 (679)	50	1943/39	2265 (509)	1.2
3.20 (4.29)	64	477 (352)	1971 (1454)	47	515/11	14923 (3355)	2.7
3.23 (4.33)	44	702 (518)	1380 (1018)	69	620/9	12344 (2775)	1.3
3.19 (4.28)	43	708 (522)	2300 (1697)	70	765/11	17027 (3828)	2.1

Servomotors

Geared servomotors for SINAMICS S120

1FK7 helical geared motors

Gearbox size	Motor shaft height	1FK7 helical geared motors				Gearbox weight, approx. kg (lb)
		Order No.	Order codes	Gearbox type	Type/gear shaft extension Type of construction/ mounting position/ connector mounting position	
C202	63	1FK7060-5AF71-1 ■■■ 5-Z	D26	G . .	H . .	22.3 (49.2)
C402	63	1FK7060-5AF71-1 ■■■ 5-Z	D46	G . .	H . .	37.6 (82.9)
C302	63	1FK7060-5AF71-1 ■■■ 5-Z	D37	G . .	H . .	27.4 (60.4)
C402	63	1FK7060-5AF71-1 ■■■ 5-Z	D47	G . .	H . .	37.6 (82.9)
C402	63	1FK7060-5AF71-1 ■■■ 5-Z	D48	G . .	H . .	37.6 (82.9)
C502	63	1FK7060-5AF71-1 ■■■ 5-Z	D58	G . .	H . .	49.2 (108)
C002	63	1FK7063-5AF71-1 ■■■ 5-Z	D01	G . .	H . .	17.1 (37.7)
C102	63	1FK7063-5AF71-1 ■■■ 5-Z	D12	G . .	H . .	22.0 (48.5)
C102	63	1FK7063-5AF71-1 ■■■ 5-Z	D13	G . .	H . .	22.0 (48.5)
C202	63	1FK7063-5AF71-1 ■■■ 5-Z	D24	G . .	H . .	26.0 (57.3)
C302	63	1FK7063-5AF71-1 ■■■ 5-Z	D35	G . .	H . .	31.1 (68.6)
C402	63	1FK7063-5AF71-1 ■■■ 5-Z	D46	G . .	H . .	41.3 (91.1)
C402	63	1FK7063-5AF71-1 ■■■ 5-Z	D47	G . .	H . .	41.3 (91.1)
C502	63	1FK7063-5AF71-1 ■■■ 5-Z	D58	G . .	H . .	52.9 (117)
C102	80	1FK7080-5AF71-1 ■■■ 5-Z	D11	G . .	H . .	21.7 (47.9)
C102	80	1FK7080-5AF71-1 ■■■ 5-Z	D12	G . .	H . .	21.7 (47.9)
C102	80	1FK7080-5AF71-1 ■■■ 5-Z	D13	G . .	H . .	21.7 (47.9)
C202	80	1FK7080-5AF71-1 ■■■ 5-Z	D24	G . .	H . .	25.7 (56.7)
C102	80	1FK7080-5AF71-1 ■■■ 5-Z	D14	G . .	H . .	21.7 (47.9)
C302	80	1FK7080-5AF71-1 ■■■ 5-Z	D35	G . .	H . .	30.8 (67.9)
C202	80	1FK7080-5AF71-1 ■■■ 5-Z	D25	G . .	H . .	25.7 (56.7)
C402	80	1FK7080-5AF71-1 ■■■ 5-Z	D46	G . .	H . .	41.0 (90.4)
C302	80	1FK7080-5AF71-1 ■■■ 5-Z	D36	G . .	H . .	30.8 (67.9)
C502	80	1FK7080-5AF71-1 ■■■ 5-Z	D57	G . .	H . .	52.6 (116)
C612	80	1FK7080-5AF71-1 ■■■ 5-Z	D68	G . .	H . .	67.9 (150)
C102	80	1FK7083-5AF71-1 ■■■ 5-Z	D11	G . .	H . .	26.9 (59.3)
C202	80	1FK7083-5AF71-1 ■■■ 5-Z	D21	G . .	H . .	30.9 (68.1)
C102	80	1FK7083-5AF71-1 ■■■ 5-Z	D12	G . .	H . .	26.9 (59.3)
C202	80	1FK7083-5AF71-1 ■■■ 5-Z	D22	G . .	H . .	30.9 (68.1)
C202	80	1FK7083-5AF71-1 ■■■ 5-Z	D23	G . .	H . .	30.9 (68.1)
C302	80	1FK7083-5AF71-1 ■■■ 5-Z	D33	G . .	H . .	36.0 (79.4)
C302	80	1FK7083-5AF71-1 ■■■ 5-Z	D34	G . .	H . .	36.0 (79.4)
C402	80	1FK7083-5AF71-1 ■■■ 5-Z	D44	G . .	H . .	46.2 (102)
C402	80	1FK7083-5AF71-1 ■■■ 5-Z	D45	G . .	H . .	46.2 (102)
C502	80	1FK7083-5AF71-1 ■■■ 5-Z	D55	G . .	H . .	57.8 (127)
C402	80	1FK7083-5AF71-1 ■■■ 5-Z	D46	G . .	H . .	46.2 (102)
C612	80	1FK7083-5AF71-1 ■■■ 5-Z	D66	G . .	H . .	73.1 (161)
C502	80	1FK7083-5AF71-1 ■■■ 5-Z	D57	G . .	H . .	57.8 (127)
C712	80	1FK7083-5AF71-1 ■■■ 5-Z	D77	G . .	H . .	108.4 (239)
C612	80	1FK7083-5AF71-1 ■■■ 5-Z	D68	G . .	H . .	73.1 (161)
C712	80	1FK7083-5AF71-1 ■■■ 5-Z	D78	G . .	H . .	108.4 (239)
Encoder systems for motors without DRIVE-CLiQ interface:	IC2048S/R encoder AM2048S/R encoder AM32S/R encoder Multi-pole resolver 2-pole resolver	A E G S T				
Encoder systems for motors with DRIVE-CLiQ interface:	IC22DQ encoder AM22DQ encoder AM16DQ encoder R15DQ resolver R14DQ resolver	D F K U P				
Holding brake:	Motor without holding brake Motor with holding brake	U V				

Order codes for type/
gear shaft extension and type of
construction/mounting position/
connector mounting position,
see page 4/86.

Servomotors

Geared servomotors for SINAMICS S120

1FK7 helical geared motors

Selection and ordering data

Power at duty type S3-60 %	Output speed at the gear shaft	Rated output torque gearbox at duty type S3-60 %	Acceleration torque, max. gearbox	Nominal ratio	Exact ratio	Cantilever force, perm., gear shaft extension	Overload factor
P_2 kW (HP)	n_2 rpm	M_2 Nm (lb _F -ft)	M_{2max} Nm (lb _F -ft)	i_{nom}	i_{exact}	F_{Tperm} N (lb _F)	f_B
Natural cooling – SH 100							
3.66 (4.91)	774 512	45.1 (33.3) 68.2 (50.3)	251 (185) 288 (212)	3.9 5.9	190/49 2584/441	1671 (376) 1917 (431)	3.7 2.8
3.64 (4.88)	322	108 (79.7)	350 (258)	9.3	3575/384	2237 (503)	2.2
3.66 (4.91)	193	181 (134)	400 (295)	15.5	544/35	2654 (597)	1.5
3.64 (4.88)	190	183 (135)	600 (443)	16	63/4	4576 (1029)	2.2
3.65 (4.89)	128 128	272 (201) 272 (201)	850 (627) 550 (406)	23 23	1495/64 1495/64	6402 (1439) 5219 (1173)	2.1 1.3
3.66 (4.91)	86	406 (300)	1380 (1018)	35	1360/39	9838 (2212)	2.3
3.65 (4.89)	66 64	528 (390) 545 (402)	1380 (1018) 2300 (1697)	45 47	136/3 515/11	1852 (416) 14923 (3355)	1.7 2.8
3.70 (4.96)	44	802 (592)	4140 (3054)	69	620/9	23146 (5203)	3.4
4.73 (6.34)	774	58.3 (43.0)	251 (185)	3.9	190/49	1671 (376)	2.5
4.72 (6.33)	512 324	88.1 (65.1) 139 (103)	288 (212) 550 (406)	5.9 9.3	2584/441 3445/372	1917 (431) 3834 (862)	1.9 2.3
	322 191	140 (103) 236 (174)	350 (258) 920 (679)	9.3 15.5	3575/384 377/24	2237 (503) 5609 (1261)	1.4 2.2
	190	237 (175)	600 (443)	16	63/4	4576 (1029)	1.5
4.70 (6.30)	128	351 (259)	850 (627)	23	1495/64	6402 (1439)	1.4
4.71 (6.32)	120	375 (277)	1650 (1217)	25	5185/208	8797 (1978)	2.5
4.75 (6.37)	86	527 (389)	2300 (1697)	35	2700/77	13552 (3047)	2.5
4.71 (6.32)	66	682 (503)	1380 (1018)	45	136/3	10737 (2414)	1.2
4.72 (6.33)	64	704 (519)	2300 (1697)	47	515/11	14923 (3355)	1.9
4.77 (6.40)	44	1036 (764)	4140 (3054)	69	620/9	23146 (5203)	2.3

Servomotors

Geared servomotors for SINAMICS S120

1FK7 helical geared motors

Gearbox size	Motor shaft height	1FK7 helical geared motors				Gearbox weight, approx. kg (lb)
		Order No.	Order codes	Gearbox type	Type/gear shaft extension Type of construction/ mounting position/ connector mounting position	
C302	100	1FK7100-5AF71-1 ■■■ 5-Z	D31	G . .	H . .	38.2 (84.2)
C302	100	1FK7100-5AF71-1 ■■■ 5-Z	D32	G . .	H . .	38.2 (84.2)
C302	100	1FK7100-5AF71-1 ■■■ 5-Z	D33	G . .	H . .	38.2 (84.2)
C302	100	1FK7100-5AF71-1 ■■■ 5-Z	D34	G . .	H . .	38.2 (84.2)
C402	100	1FK7100-5AF71-1 ■■■ 5-Z	D44	G . .	H . .	48.4 (107)
C502	100	1FK7100-5AF71-1 ■■■ 5-Z	D55	G . .	H . .	60.0 (132)
C402	100	1FK7100-5AF71-1 ■■■ 5-Z	D45	G . .	H . .	48.4 (107)
C612	100	1FK7100-5AF71-1 ■■■ 5-Z	D66	G . .	H . .	75.3 (166)
C612	100	1FK7100-5AF71-1 ■■■ 5-Z	D67	G . .	H . .	75.3 (166)
C712	100	1FK7100-5AF71-1 ■■■ 5-Z	D77	G . .	H . .	110.6 (244)
C812	100	1FK7100-5AF71-1 ■■■ 5-Z	D88	G . .	H . .	170.2 (375)
C302	100	1FK7101-5AF71-1 ■■■ 5-Z	D31	G . .	H . .	43.8 (96.6)
C302	100	1FK7101-5AF71-1 ■■■ 5-Z	D32	G . .	H . .	43.8 (96.6)
C402	100	1FK7101-5AF71-1 ■■■ 5-Z	D43	G . .	H . .	43.8 (96.6)
C302	100	1FK7101-5AF71-1 ■■■ 5-Z	D33	G . .	H . .	54.0 (119)
C502	100	1FK7101-5AF71-1 ■■■ 5-Z	D54	G . .	H . .	65.6 (145)
C402	100	1FK7101-5AF71-1 ■■■ 5-Z	D44	G . .	H . .	54.0 (119)
C502	100	1FK7101-5AF71-1 ■■■ 5-Z	D55	G . .	H . .	65.6 (145)
C612	100	1FK7101-5AF71-1 ■■■ 5-Z	D65	G . .	H . .	80.9 (178)
C712	100	1FK7101-5AF71-1 ■■■ 5-Z	D76	G . .	H . .	116.2 (256)
C612	100	1FK7101-5AF71-1 ■■■ 5-Z	D67	G . .	H . .	80.9 (178)
C712	100	1FK7101-5AF71-1 ■■■ 5-Z	D77	G . .	H . .	116.2 (256)
C812	100	1FK7101-5AF71-1 ■■■ 5-Z	D88	G . .	H . .	175.8 (388)
Encoder systems for motors without DRIVE-CLiQ interface:	IC2048S/R encoder AM2048S/R encoder AM32S/R encoder Multi-pole resolver 2-pole resolver	A E G S T				
Encoder systems for motors with DRIVE-CLiQ interface:	IC22DQ encoder AM22DQ encoder AM16DQ encoder R15DQ resolver R14DQ resolver	D F K U P				
Holding brake:	Motor without holding brake Motor with holding brake	U V				

Order codes for type/
gear shaft extension and type of
construction/mounting position/
connector mounting position,
see page 4/86.

Servomotors

Geared servomotors for SINAMICS S120

1FK7 helical geared motors

Selection and ordering data

Power at duty type S3-60 %	Output speed at the gear shaft	Rated output torque gearbox at duty type S3-60 %	Acceleration torque, max. gearbox	Nominal ratio	Exact ratio	Cantilever force, perm., gear shaft extension	Overload factor
P_2	n_2	M_2	M_{2max}	i_{nom}	i_{exact}	F_{Tperm}	f_B
kW (HP)	rpm	Nm (lb _f -ft)	Nm (lb _f -ft)			N (lb _f)	
Natural cooling – SH 100							
5.19 (6.96)	644	77 (56.8)	251 (185)	3.9	190/49	1671 (376)	1.9
5.18 (6.95)	423	117 (86.3)	288 (212)	5.9	2584/441	1917 (431)	2.0
5.19 (6.96)	424	117 (86.3)	420 (310)	5.9	377/64	3297 (741)	1.4
5.18 (6.95)	269	184 (136)	350 (258)	9.3	3575/384	2237 (503)	2.5
5.20 (6.97)	241	206 (152)	850 (627)	9.3	3445/372	4886 (1098)	1.1
5.21 (6.99)	159	313 (231)	600 (443)	16	63/4	4576 (1029)	1.1
5.19 (6.96)	154	322 (238)	1650 (1217)	16	1037/64	7620 (1713)	2.9
5.20 (6.97)	107	464 (342)	850 (627)	23	1495/64	6402 (1439)	1.9
5.19 (6.96)	100	496 (366)	1650 (1217)	25	5185/208	8797 (1978)	1.1
5.23 (7.01)	72 71	694 (512) 703 (519)	1380 (1018) 4140 (3054)	35 35	1360/39 106/3	9838 (2212) 18528 (4165)	3.4 1.1
5.17 (6.93)	53	931 (687)	2300 (1697)	47	515/11	14923 (3355)	2.2
5.18 (6.95)	46	1076 (794)	4140 (3054)	54	704/13	21362 (4802)	1.2
5.16 (6.92)	36	1370 (1011)	4140 (3054)	69	620/9	23146 (5203)	1.1
7.92 (10.6)	770	98.2 (72.4)	366 (270)	3.9	841/216	2872 (646)	2.0
7.93 (10.6)	774	97.8 (72.1)	251 (185)	3.9	190/49	1671 (377)	1.4
7.95 (10.7)	513	148 (109)	650 (479)	5.9	117/20	4036 (907)	2.4
7.93 (10.6)	512	148 (109)	288 (212)	5.9	2584/441	1917 (431)	1.1
7.94 (10.7)	324 324	234 (173) 234 (173)	850 (627) 550 (406)	9.3 9.3	3445/372 3445/372	4703 (1057) 3834 (862)	2.0 1.3
7.92 (10.6)	191 185	396 (292) 409 (302)	920 (679) 1650 (1217)	16 16	377/24 1037/64	5609 (1261) 7620 (1713)	1.3 2.2
7.90 (10.6)	129 120	585 (432) 629 (464)	2300 (1697) 1650 (1217)	23 25	255/11 5185/208	11806 (2654) 8797 (1978)	2.1 1.4
7.93 (10.6)	85	891 (657)	4140 (3054)	36	106/3	18528 (4165)	2.5
7.96 (10.7)	86	884 (652)	2300 (1697)	35	2700/77	13552 (3047)	1.4
7.93 (10.6)	66	1148 (847)	4140 (3054)	46	592/13	20163 (4533)	2.0
7.91 (10.6)	64	1181 (871)	2300 (1697)	47	515/11	14923 (3355)	1.1
8.00 (10.7)	44	1737 (1281)	4140 (3054)	69	620/9	23146 (5203)	1.3

Servomotors

Geared servomotors for SINAMICS S120

1FK7 helical geared motors

Gearbox size	Motor shaft height	1FK7 helical geared motors				Gearbox weight, approx. kg (lb)
		Order No.	Order codes	Gearbox type	Type/gear shaft extension Type of construction/ mounting position/ connector mounting position	
SH						
C302	100	1FK7103-5AF71-1 ■■■ 5-Z	D31	G . .	H . .	50.4 (111)
C302	100	1FK7103-5AF71-1 ■■■ 5-Z	D32	G . .	H . .	50.4 (111)
C402	100	1FK7103-5AF71-1 ■■■ 5-Z	D42	G . .	H . .	60.6 (134)
C302	100	1FK7103-5AF71-1 ■■■ 5-Z	D33	G . .	H . .	50.4 (111)
C502	100	1FK7103-5AF71-1 ■■■ 5-Z	D53	G . .	H . .	72.2 (159)
C402	100	1FK7103-5AF71-1 ■■■ 5-Z	D44	G . .	H . .	60.6 (134)
C612	100	1FK7103-5AF71-1 ■■■ 5-Z	D64	G . .	H . .	87.5 (193)
C502	100	1FK7103-5AF71-1 ■■■ 5-Z	D55	G . .	H . .	72.2 (159)
C612	100	1FK7103-5AF71-1 ■■■ 5-Z	D65	G . .	H . .	87.5 (193)
C612	100	1FK7103-5AF71-1 ■■■ 5-Z	D66	G . .	H . .	87.5 (193)
C812	100	1FK7103-5AF71-1 ■■■ 5-Z	D86	G . .	H . .	182.4 (402)
C712	100	1FK7103-5AF71-1 ■■■ 5-Z	D77	G . .	H . .	122.8 (271)
C812	100	1FK7103-5AF71-1 ■■■ 5-Z	D87	G . .	H . .	182.4 (402)
C812	100	1FK7103-5AF71-1 ■■■ 5-Z	D88	G . .	H . .	182.4 (402)
C402	100	1FK7105-5AF71-1 ■■■ 5-Z	D41	G . .	H . .	70.6 (156)
C302	100	1FK7105-5AF71-1 ■■■ 5-Z	D31	G . .	H . .	60.4 (133)
C502	100	1FK7105-5AF71-1 ■■■ 5-Z	D52	G . .	H . .	82.2 (181)
C302	100	1FK7105-5AF71-1 ■■■ 5-Z	D32	G . .	H . .	60.4 (133)
C502	100	1FK7105-5AF71-1 ■■■ 5-Z	D53	G . .	H . .	82.2 (181)
C402	100	1FK7105-5AF71-1 ■■■ 5-Z	D43	G . .	H . .	70.6 (156)
C502	100	1FK7105-5AF71-1 ■■■ 5-Z	D54	G . .	H . .	82.2 (181)
C612	100	1FK7105-5AF71-1 ■■■ 5-Z	D64	G . .	H . .	97.5 (215)
C712	100	1FK7105-5AF71-1 ■■■ 5-Z	D75	G . .	H . .	132.8 (293)
C612	100	1FK7105-5AF71-1 ■■■ 5-Z	D65	G . .	H . .	97.5 (215)
C812	100	1FK7105-5AF71-1 ■■■ 5-Z	D86	G . .	H . .	192.4 (424)
C712	100	1FK7105-5AF71-1 ■■■ 5-Z	D76	G . .	H . .	132.8 (293)
C812	100	1FK7105-5AF71-1 ■■■ 5-Z	D87	G . .	H . .	192.4 (424)
C712	100	1FK7105-5AF71-1 ■■■ 5-Z	D77	G . .	H . .	132.8 (293)
C812	100	1FK7105-5AF71-1 ■■■ 5-Z	D88	G . .	H . .	192.4 (424)
Encoder systems for motors without DRIVE-CLiQ interface:	IC2048S/R encoder AM2048S/R encoder AM32S/R encoder Multi-pole resolver 2-pole resolver			A E G S T		
Encoder systems for motors with DRIVE-CLiQ interface:	IC22DQ encoder AM22DQ encoder AM16DQ encoder R15DQ resolver R14DQ resolver			D F K U P		
Holding brake:	Motor <u>without</u> holding brake Motor <u>with</u> holding brake			U V		

Order codes for type/
gear shaft extension and type of
construction/mounting position/
connector mounting position,
see page 4/86.

Servomotors

Geared servomotors for SINAMICS S120

1FK7 offset-shaft geared motors

Selection and ordering data

Power at duty type S3-60 %	Output speed at the gear shaft	Rated output torque gearbox at duty type S3-60 %	Acceleration torque, max. gearbox	Nominal ratio	Exact ratio	Cantilever force, perm., gear shaft extension	Overload factor
P_2	n_2	M_2	M_{2max}	i_{nom}	i_{exact}	F_{rperm}	f_B
kW (HP)	rpm	Nm (lb _f -ft)	Nm (lb _f -ft)			N (lb _f)	
Natural cooling – SH 36/SH 48/SH 63							
0.30 (0.40)	696	4.07 (3.00)	24 (17.7)	4.3	56/13	1021 (230)	4.7
	464	6.11 (4.51)	33 (24.3)	6.5	84/13	1169 (263)	4.5
	275	10.3 (7.60)	52 (38.4)	11	273/25	1392 (313)	4.1
	221	12.9 (9.52)	62 (45.7)	13.5	231/17	1497 (337)	3.9
	130	21.8 (16.1)	114 (84.1)	23	3185/138	1786 (402)	4.2
	86	33.1 (24.4)	120 (88.5)	35	3575/102	2053 (462)	2.9
0.41 (0.55)	696	5.64 (4.16)	45 (33.2)	4.3	56/13	1021 (230)	6.7
	464	8.46 (6.24)	64 (47.2)	6.5	84/13	1169 (263)	6.3
	275	14.3 (10.5)	99 (73.0)	11	273/25	1392 (313)	5.8
	221	17.8 (13.1)	105 (77.4)	13.5	231/17	1497 (337)	5.0
	130	30.2 (22.3)	120 (88.5)	23	3185/138	1786 (402)	3.4
	86	45.9 (33.9)	120 (88.5)	35	3575/102	2053 (462)	2.2
0.79 (1.06)	696	10.9 (8.00)	45 (33.2)	4.3	56/13	1021 (230)	3.6
	464	16.3 (12.0)	64 (47.2)	6.5	84/13	1169 (263)	3.4
	275	27.5 (20.3)	99 (73.0)	11	273/25	1392 (313)	3.1
	221	34.3 (25.3)	105 (77.4)	13.5	231/17	1497 (337)	2.7
	130	58.2 (42.9)	120 (88.5)	23	3185/138	1786 (402)	1.8
	128	59.1 (43.6)	233 (172)	23	2320/99	2308 (519)	3.4
1.43 (1.92)	86	88.4 (65.2)	120 (88.5)	35	3575/102	2053 (462)	1.2
	85	89.4 (65.9)	270 (199)	35	390/11	2650 (596)	2.6
	696	19.6 (14.5)	80 (59.0)	4.3	56/13	1021 (230)	3.2
	464	29.5 (21.8)	91 (67.1)	6.5	84/13	1169 (263)	2.4
	275	49.8 (36.7)	105 (77.4)	11	273/25	1392 (313)	1.7
	278	49.3 (36.4)	196 (145)	11	7303/676	1783 (402)	3.1
2.22 (2.98)	221	61.9 (45.7)	105 (77.4)	13.5	231/17	1497 (337)	1.3
	220	62.1 (45.8)	210 (155)	13.5	109/8	1927 (433)	2.6
	128	107 (78.9)	270 (199)	23	2320/99	2308 (519)	2.0
	85	162 (120)	270 (199)	35	390/11	2650 (596)	1.3
	86	160 (118)	450 (332)	35	7252/207	3666 (824)	2.2
	696	30.5 (22.5)	80 (59.0)	4.3	56/13	1021 (230)	1.7
464	45.8 (33.8)	91 (67.1)	6.5	84/13	1169 (263)	1.3	
2.22 (2.98)	540	39.3 (29.0)	112 (82.6)	5.6	5341/962	1428 (321)	1.9
	278	76.5 (56.4)	196 (145)	11	7303/676	1783 (401)	1.7
	220	96.5 (71.2)	210 (155)	13.5	109/8	1927 (433)	1.4
	128	166 (122)	270 (199)	23	2320/99	2308 (519)	1.1
	86	248 (183)	450 (332)	35	7252/207	3666 (824)	1.2

Servomotors

Geared servomotors for SINAMICS S120

1FK7 offset-shaft geared motors

Gearbox size	Motor shaft height	1FK7 offset-shaft geared motors				Gearbox weight, approx. kg (lb)
		Order No.	Order codes	Gearbox type	Type/gear shaft extension Type of construction/ mounting position/ connector mounting position	
F102	36	1FK7032-5AK71-1 ■■■ 5-Z	C11	G . .	H . .	13.8 (30.4)
F102	36	1FK7032-5AK71-1 ■■■ 5-Z	C12	G . .	H . .	13.8 (30.4)
F102	36	1FK7032-5AK71-1 ■■■ 5-Z	C13	G . .	H . .	13.8 (30.4)
F102	36	1FK7032-5AK71-1 ■■■ 5-Z	C14	G . .	H . .	13.8 (30.4)
F102	36	1FK7032-5AK71-1 ■■■ 5-Z	C15	G . .	H . .	13.8 (30.4)
F102	36	1FK7032-5AK71-1 ■■■ 5-Z	C16	G . .	H . .	13.8 (30.4)
F102	48	1FK7040-5AK71-1 ■■■ 5-Z	C11	G . .	H . .	14.6 (32.2)
F102	48	1FK7040-5AK71-1 ■■■ 5-Z	C12	G . .	H . .	14.6 (32.2)
F102	48	1FK7040-5AK71-1 ■■■ 5-Z	C13	G . .	H . .	14.6 (32.2)
F102	48	1FK7040-5AK71-1 ■■■ 5-Z	C14	G . .	H . .	14.6 (32.2)
F102	48	1FK7040-5AK71-1 ■■■ 5-Z	C15	G . .	H . .	14.6 (32.2)
F102	48	1FK7040-5AK71-1 ■■■ 5-Z	C16	G . .	H . .	14.6 (32.2)
F102	48	1FK7042-5AF71-1 ■■■ 5-Z	C11	G . .	H . .	15.9 (35.1)
F102	48	1FK7042-5AF71-1 ■■■ 5-Z	C12	G . .	H . .	15.9 (35.1)
F102	48	1FK7042-5AF71-1 ■■■ 5-Z	C13	G . .	H . .	15.9 (35.1)
F102	48	1FK7042-5AF71-1 ■■■ 5-Z	C14	G . .	H . .	15.9 (35.1)
F102	48	1FK7042-5AF71-1 ■■■ 5-Z	C15	G . .	H . .	15.9 (35.1)
F202	48	1FK7042-5AF71-1 ■■■ 5-Z	C25	G . .	H . .	24.1 (53.1)
F102	48	1FK7042-5AF71-1 ■■■ 5-Z	C16	G . .	H . .	15.9 (35.1)
F202	48	1FK7042-5AF71-1 ■■■ 5-Z	C26	G . .	H . .	24.1 (53.1)
F102	63	1FK7060-5AF71-1 ■■■ 5-Z	C11	G . .	H . .	18.6 (41.0)
F102	63	1FK7060-5AF71-1 ■■■ 5-Z	C12	G . .	H . .	18.6 (41.0)
F102	63	1FK7060-5AF71-1 ■■■ 5-Z	C13	G . .	H . .	18.6 (41.0)
F202	63	1FK7060-5AF71-1 ■■■ 5-Z	C23	G . .	H . .	26.8 (59.1)
F102	63	1FK7060-5AF71-1 ■■■ 5-Z	C14	G . .	H . .	18.6 (41.0)
F202	63	1FK7060-5AF71-1 ■■■ 5-Z	C24	G . .	H . .	26.8 (59.1)
F202	63	1FK7060-5AF71-1 ■■■ 5-Z	C25	G . .	H . .	26.8 (59.1)
F202	63	1FK7060-5AF71-1 ■■■ 5-Z	C26	G . .	H . .	26.8 (59.1)
F302	63	1FK7060-5AF71-1 ■■■ 5-Z	C36	G . .	H . .	34.4 (75.9)
F102	63	1FK7063-5AF71-1 ■■■ 5-Z	C11	G . .	H . .	22.3 (49.2)
F102	63	1FK7063-5AF71-1 ■■■ 5-Z	C12	G . .	H . .	22.3 (49.2)
F202	63	1FK7063-5AF71-1 ■■■ 5-Z	C22	G . .	H . .	30.5 (67.3)
F202	63	1FK7063-5AF71-1 ■■■ 5-Z	C23	G . .	H . .	30.5 (67.3)
F202	63	1FK7063-5AF71-1 ■■■ 5-Z	C24	G . .	H . .	30.5 (67.3)
F202	63	1FK7063-5AF71-1 ■■■ 5-Z	C25	G . .	H . .	30.5 (67.3)
F302	63	1FK7063-5AF71-1 ■■■ 5-Z	C36	G . .	H . .	38.1 (84.0)

Encoder systems for motors without DRIVE-CLiQ interface:	IC2048S/R encoder	A E H G J S T
	AM2048S/R encoder (from shaft height 48)	
	AM512S/R encoder (shaft height 36 only)	
	AM32S/R encoder (from shaft height 48)	
	AM16S/R encoder (shaft height 36 only)	
	Multi-pole resolver 2-pole resolver	
Encoder systems for motors with DRIVE-CLiQ interface:	IC22DQ encoder	D F L K V U P
	AM22DQ encoder (from shaft height 48)	
	AM20DQ encoder (shaft height 36 only)	
	AM16DQ encoder (from shaft height 48)	
	AM15DQ encoder (shaft height 36 only)	
	R15DQ resolver R14DQ resolver	
Holding brake:	Motor <u>without</u> holding brake	U V
	Motor <u>with</u> holding brake	

Order codes for type/
gear shaft extension and type of
construction/mounting position/
connector mounting position,
see page 4/86.

Servomotors

Geared servomotors for SINAMICS S120

1FK7 offset-shaft geared motors

Selection and ordering data

Power at duty type S3-60 %	Output speed at the gear shaft	Rated output torque gearbox at duty type S3-60 %	Acceleration torque, max. gearbox	Nominal ratio	Exact ratio	Cantilever force, perm., gear shaft extension	Overload factor
P_2	n_2	M_2	M_{2max}	i_{nom}	i_{exact}	F_{rperm}	f_B
kW (HP)	rpm	Nm (lb _r -ft)	Nm (lb _r -ft)			N (lb _r)	
Natural cooling – SH 80/SH 100							
2.08 (2.79)	540	36.6 (27.0)	173 (128)	5.6	5341/962	1428 (321)	4.0
	278	71.3 (52.6)	210 (155)	11	7303/676	1783 (401)	2.5
	220	89.9 (66.3)	210 (155)	13.5	109/8	1927 (433)	2.0
	128	155 (114)	270 (199)	23	2320/99	2308 (519)	1.5
	128	155 (114)	450 (332)	24	588/25	3210 (722)	2.5
	86	231 (170)	450 (332)	35	7252/207	3666 (824)	1.7
3.20 (4.29)	540	56.5 (41.7)	173 (128)	5.6	5341/962	1428 (321)	2.0
	278	110 (81.1)	210 (155)	11	7303/676	1783 (401)	1.3
	278	110 (81.1)	350 (258)	11	1456/135	2475 (556)	2.1
	224	136 (100)	350 (258)	13.5	7696/575	2660 (598)	1.7
	221	138 (102)	550 (406)	13.5	5984/441	3296 (741)	2.6
	128	240 (177)	450 (332)	24	588/25	3210 (722)	1.2
3.66 (4.91)	129	236 (174)	700 (516)	23	325/14	3942 (886)	1.9
	86	357 (263)	700 (516)	35	2210/63	4523 (1017)	1.3
	85	359 (265)	1100 (811)	35	845/24	6120 (1376)	2.0
	516	67.7 (49.9)	482 (356)	5.8	3784/651	2484 (558)	4.8
	277	126 (92.9)	550 (406)	11	682/63	3057 (687)	2.9
	221	158 (117)	550 (406)	13.5	5984/441	3296 (741)	2.3
4.72 (6.33)	129	270 (199)	700 (516)	23	325/14	3942 (886)	1.7
	129	271 (200)	1100 (811)	23	1885/81	5331 (1198)	2.7
	86	408 (301)	700 (516)	35	2210/63	4523 (1017)	1.1
	516	87.4 (64.5)	482 (356)	5.8	3784/651	2484 (558)	3.2
	277	163 (120)	550 (406)	11	682/63	3057 (687)	1.9
	221	204 (151)	550 (406)	13.5	5984/441	3296 (741)	1.5
5.20 (6.97)	220	205 (151)	1000 (738)	13.5	871/64	4458 (1002)	2.8
	129	349 (257)	700 (516)	23	325/14	3942 (886)	1.2
	85	529 (390)	1100 (811)	35	845/24	6120 (1376)	1.2
	430	115 (84.8)	482 (356)	5.8	3784/651	2484 (558)	2.4
	231	215 (159)	550 (406)	11	682/63	3057 (687)	1.5
	231	215 (159)	991 (731)	11	2077/192	4130 (928)	2.6
7.93 (10.6)	184	269 (198)	550 (406)	13.5	5984/441	3296 (741)	1.2
	183	270 (199)	1000 (738)	13.5	871/64	4458 (1002)	2.1
	108	460 (339)	1100 (811)	23	1885/81	5331 (1198)	1.4
	529	143 (106)	766 (565)	5.7	1407/248	3330 (749)	2.9
	516	147 (108)	482 (356)	6	3784/651	2484 (558)	1.8
	277	273 (201)	991 (731)	11	2077/192	4130 (928)	2.0
7.93 (10.6)	277	273 (201)	550 (406)	11	682/63	3057 (687)	1.1
	220	343 (253)	1000 (738)	13.6	871/64	4458 (1002)	1.6
	129	587 (433)	1100 (811)	24	1885/81	5331 (1198)	1.0

Servomotors

Geared servomotors for SINAMICS S120

1FK7 offset-shaft geared motors

Gearbox size	Motor shaft height	1FK7 offset-shaft geared motors				Gearbox weight, approx. kg (lb)
		Order No.	Order codes	Type/gear shaft extension	Type of construction/ mounting position/ connector mounting position	
F202	80	1FK7080-5AF71-1 ■■■ 5-Z	C22	G . .	H . .	30.2 (66.6)
F202	80	1FK7080-5AF71-1 ■■■ 5-Z	C23	G . .	H . .	30.2 (66.6)
F202	80	1FK7080-5AF71-1 ■■■ 5-Z	C24	G . .	H . .	30.2 (66.6)
F202	80	1FK7080-5AF71-1 ■■■ 5-Z	C25	G . .	H . .	30.2 (66.6)
F302	80	1FK7080-5AF71-1 ■■■ 5-Z	C35	G . .	H . .	37.8 (83.4)
F302	80	1FK7080-5AF71-1 ■■■ 5-Z	C36	G . .	H . .	37.8 (83.4)
F402	80	1FK7080-5AF71-1 ■■■ 5-Z	C46	G . .	H . .	46.1 (102)
F202	80	1FK7083-5AF71-1 ■■■ 5-Z	C22	G . .	H . .	35.4 (78.1)
F202	80	1FK7083-5AF71-1 ■■■ 5-Z	C23	G . .	H . .	35.4 (78.1)
F302	80	1FK7083-5AF71-1 ■■■ 5-Z	C33	G . .	H . .	43.0 (94.8)
F302	80	1FK7083-5AF71-1 ■■■ 5-Z	C34	G . .	H . .	43.0 (94.8)
F402	80	1FK7083-5AF71-1 ■■■ 5-Z	C44	G . .	H . .	51.3 (113)
F302	80	1FK7083-5AF71-1 ■■■ 5-Z	C35	G . .	H . .	43.0 (94.8)
F402	80	1FK7083-5AF71-1 ■■■ 5-Z	C45	G . .	H . .	51.3 (113)
F402	80	1FK7083-5AF71-1 ■■■ 5-Z	C46	G . .	H . .	51.3 (113)
F602	80	1FK7083-5AF71-1 ■■■ 5-Z	C66	G . .	H . .	78.3 (173)
F402	100	1FK7100-5AF71-1 ■■■ 5-Z	C42	G . .	H . .	53.5 (118)
F402	100	1FK7100-5AF71-1 ■■■ 5-Z	C43	G . .	H . .	53.3 (118)
F402	100	1FK7100-5AF71-1 ■■■ 5-Z	C44	G . .	H . .	53.5 (118)
F402	100	1FK7100-5AF71-1 ■■■ 5-Z	C45	G . .	H . .	53.3 (118)
F602	100	1FK7100-5AF71-1 ■■■ 5-Z	C65	G . .	H . .	80.5 (178)
F402	100	1FK7100-5AF71-1 ■■■ 5-Z	C46	G . .	H . .	53.3 (118)
F402	100	1FK7101-5AF71-1 ■■■ 5-Z	C42	G . .	H . .	59.1 (130)
F402	100	1FK7101-5AF71-1 ■■■ 5-Z	C43	G . .	H . .	59.1 (130)
F402	100	1FK7101-5AF71-1 ■■■ 5-Z	C44	G . .	H . .	59.1 (130)
F602	100	1FK7101-5AF71-1 ■■■ 5-Z	C64	G . .	H . .	86.1 (190)
F402	100	1FK7101-5AF71-1 ■■■ 5-Z	C45	G . .	H . .	59.1 (130)
F602	100	1FK7101-5AF71-1 ■■■ 5-Z	C66	G . .	H . .	86.1 (190)
F402	100	1FK7103-5AF71-1 ■■■ 5-Z	C42	G . .	H . .	65.7 (145)
F402	100	1FK7103-5AF71-1 ■■■ 5-Z	C43	G . .	H . .	65.7 (145)
F602	100	1FK7103-5AF71-1 ■■■ 5-Z	C63	G . .	H . .	92.7 (204)
F402	100	1FK7103-5AF71-1 ■■■ 5-Z	C44	G . .	H . .	65.7 (145)
F602	100	1FK7103-5AF71-1 ■■■ 5-Z	C64	G . .	H . .	92.7 (145)
F602	100	1FK7103-5AF71-1 ■■■ 5-Z	C65	G . .	H . .	92.7 (145)
F602	100	1FK7105-5AF71-1 ■■■ 5-Z	C62	G . .	H . .	103 (227)
F402	100	1FK7105-5AF71-1 ■■■ 5-Z	C42	G . .	H . .	75.7 (167)
F602	100	1FK7105-5AF71-1 ■■■ 5-Z	C63	G . .	H . .	103 (227)
F402	100	1FK7105-5AF71-1 ■■■ 5-Z	C43	G . .	H . .	75.7 (167)
F602	100	1FK7105-5AF71-1 ■■■ 5-Z	C64	G . .	H . .	103 (227)
F602	100	1FK7105-5AF71-1 ■■■ 5-Z	C65	G . .	H . .	103 (227)

Encoder systems for motors without DRIVE-CLiQ interface: IC2048S/R encoder
AM2048S/R encoder
AM32S/R encoder
Multi-pole resolver
2-pole resolver

Encoder systems for motors with DRIVE-CLiQ interface: IC22DQ encoder
AM22DQ encoder
AM16DQ encoder
R15DQ resolver
R14DQ resolver

Holding brake: Motor without holding brake
Motor with holding brake

A
E
G
S
T

D
F
K
U
P

U
V

.. ..
Order codes for type/
gear shaft extension and type of
construction/mounting position/
connector mounting position,
see page 4/86.

Servomotors

Geared servomotors for SINAMICS S120

1FK7 bevel geared motors

Selection and ordering data

Power at duty type S3-60 %	Output speed at the gear shaft	Rated output torque gearbox at duty type S3-60 %	Acceleration torque, max. gearbox	Nominal ratio	Exact ratio	Cantilever force, perm., gear shaft extension	Overload factor
P_2	n_2	M_2	M_{2max}	i_{nom}	i_{exact}	F_{rperm}	f_B
kW (HP)	rpm	Nm (lb _f -ft)	Nm (lb _f -ft)			N (lb _f)	
Natural cooling – SH 36/SH 48/SH 63							
0.30 (0.40)	750	3.78 (2.79)	22 (16.2)	4	4/1	1494 (336)	4.7
	500	5.68 (4.19)	31 (22.9)	6	6/1	1710 (384)	4.5
	296	9.59 (7.07)	48 (35.4)	10	507/50	2037 (458)	4.1
	179	15.8 (11.7)	73 (53.8)	16.5	117/7	2406 (541)	3.8
	129	22.0 (16.2)	102 (75.2)	23	1140/49	2686 (604)	3.8
85	33.2 (24.5)	135 (99.6)	35	3686/105	3081 (693)	3.3	
65	43.7 (32.2)	185 (137)	46	1849/40	4053 (911)	3.4	
	43	65.7 (48.5)	159 (117)	69	6665/96	4641 (1043)	2.0
0.41 (0.55)	750	5.24 (3.87)	42 (31.0)	4	4/1	1494 (336)	6.7
	500	7.86 (5.80)	59 (43.5)	6	6/1	1710 (384)	6.3
	296	13.3 (9.81)	92 (67.9)	10	507/50	2037 (458)	5.8
	179	21.9 (16.2)	122 (90.0)	16.5	117/7	2406 (541)	4.7
	129	30.5 (22.5)	135 (99.6)	23	1140/49	2686 (604)	3.7
85	46.0 (33.9)	135 (99.6)	35	3686/105	3081 (693)	2.5	
65	60.5 (44.6)	220 (162)	46	1849/40	4053 (911)	3.1	
0.79 (1.06)	750	10.1 (7.45)	42 (31.0)	4	4/1	1494 (336)	3.6
	500	15.1 (11.1)	59 (43.5)	6	6/1	1710 (384)	3.4
	296	25.6 (18.9)	92 (67.9)	10	507/50	2037 (458)	3.1
	179	42.2 (31.1)	122 (90.0)	16.5	117/7	2406 (541)	2.5
	129	58.7 (43.3)	135 (99.6)	23	1140/49	2686 (604)	2.0
85	88.5 (65.3)	135 (99.6)	35	3686/105	3081 (693)	1.3	
87	87.1 (64.2)	220 (162)	35	1935/56	3678 (1043)	2.2	
1.43 (1.92)	750	18.2 (13.4)	76 (56.1)	4	4/1	1494 (336)	3.3
	500	27.4 (20.2)	87 (64.2)	6	6/1	1710 (384)	2.5
	296	46.2 (34.1)	103 (76.0)	10	507/50	2037 (458)	1.8
	178	76.9 (56.7)	219 (162)	17	2967/176	2895 (651)	2.2
	129	106 (78.2)	220 (162)	23	2967/128	3220 (724)	1.6
	129	106 (78.2)	385 (284)	23	559/24	3762 (846)	2.8
	87	158 (117)	220 (162)	35	1935/56	3678 (1043)	1.1
	86	158 (117)	385 (284)	35	903/26	4298 (966)	1.9
	65	211 (156)	385 (284)	46	1849/40	4728 (1063)	1.4
65	211 (156)	600 (443)	46	602/13	7570 (1702)	2.2	
46	290 (214)	1000 (738)	65	12586/195	10154 (2283)	2.7	

Servomotors

Geared servomotors for SINAMICS S120

1FK7 bevel geared motors

4

Gearbox size	Motor shaft height	1FK7 bevel geared motors					Gearbox weight, approx. kg (lb)
		Order No.	Order codes	Gearbox type	Type/gear shaft extension	Type of construction/ mounting position/ connector mounting position	
K102	36	1FK7032-5AK71-1 ■■■ 5-Z	B11	G . .	H . .	12.3 (27.1)	
K102	36	1FK7032-5AK71-1 ■■■ 5-Z	B12	G . .	H . .	12.3 (27.1)	
K102	36	1FK7032-5AK71-1 ■■■ 5-Z	B13	G . .	H . .	12.3 (27.1)	
K102	36	1FK7032-5AK71-1 ■■■ 5-Z	B14	G . .	H . .	12.3 (27.1)	
K102	36	1FK7032-5AK71-1 ■■■ 5-Z	B15	G . .	H . .	12.3 (27.1)	
K102	36	1FK7032-5AK71-1 ■■■ 5-Z	B16	G . .	H . .	12.3 (27.1)	
K202	36	1FK7032-5AK71-1 ■■■ 5-Z	B27	G . .	H . .	19.8 (43.7)	
K202	36	1FK7032-5AK71-1 ■■■ 5-Z	B28	G . .	H . .	19.8 (43.7)	
K102	48	1FK7040-5AK71-1 ■■■ 5-Z	B11	G . .	H . .	13.1 (28.9)	
K102	48	1FK7040-5AK71-1 ■■■ 5-Z	B12	G . .	H . .	13.1 (28.9)	
K102	48	1FK7040-5AK71-1 ■■■ 5-Z	B13	G . .	H . .	13.1 (28.9)	
K102	48	1FK7040-5AK71-1 ■■■ 5-Z	B14	G . .	H . .	13.1 (28.9)	
K102	48	1FK7040-5AK71-1 ■■■ 5-Z	B15	G . .	H . .	13.1 (28.9)	
K102	48	1FK7040-5AK71-1 ■■■ 5-Z	B16	G . .	H . .	13.1 (28.9)	
K202	48	1FK7040-5AK71-1 ■■■ 5-Z	B27	G . .	H . .	20.6 (45.4)	
K102	48	1FK7042-5AF71-1 ■■■ 5-Z	B11	G . .	H . .	14.4 (31.8)	
K102	48	1FK7042-5AF71-1 ■■■ 5-Z	B12	G . .	H . .	14.4 (31.8)	
K102	48	1FK7042-5AF71-1 ■■■ 5-Z	B13	G . .	H . .	14.4 (31.8)	
K102	48	1FK7042-5AF71-1 ■■■ 5-Z	B14	G . .	H . .	14.4 (31.8)	
K102	48	1FK7042-5AF71-1 ■■■ 5-Z	B15	G . .	H . .	14.4 (31.8)	
K102	48	1FK7042-5AF71-1 ■■■ 5-Z	B16	G . .	H . .	14.4 (31.8)	
K202	48	1FK7042-5AF71-1 ■■■ 5-Z	B26	G . .	H . .	21.9 (48.3)	
K102	63	1FK7060-5AF71-1 ■■■ 5-Z	B11	G . .	H . .	17.1 (37.7)	
K102	63	1FK7060-5AF71-1 ■■■ 5-Z	B12	G . .	H . .	17.1 (37.7)	
K102	63	1FK7060-5AF71-1 ■■■ 5-Z	B13	G . .	H . .	17.1 (37.7)	
K202	63	1FK7060-5AF71-1 ■■■ 5-Z	B24	G . .	H . .	24.6 (54.2)	
K202	63	1FK7060-5AF71-1 ■■■ 5-Z	B25	G . .	H . .	24.6 (54.2)	
K302	63	1FK7060-5AF71-1 ■■■ 5-Z	B35	G . .	H . .	29.6 (65.3)	
K202	63	1FK7060-5AF71-1 ■■■ 5-Z	B26	G . .	H . .	24.6 (54.2)	
K302	63	1FK7060-5AF71-1 ■■■ 5-Z	B36	G . .	H . .	29.6 (65.3)	
K302	63	1FK7060-5AF71-1 ■■■ 5-Z	B37	G . .	H . .	29.6 (65.3)	
K402	63	1FK7060-5AF71-1 ■■■ 5-Z	B47	G . .	H . .	43.1 (95.0)	
K513	63	1FK7060-5AF71-1 ■■■ 5-Z	B58	G . .	H . .	48.9 (108)	

Encoder systems for motors without DRIVE-CLiQ interface:	IC2048S/R encoder	A E H G J S T
	AM2048S/R encoder (from shaft height 48)	
	AM512S/R encoder (shaft height 36 only)	
	AM32S/R encoder (from shaft height 48)	
	AM16S/R encoder (shaft height 36 only)	
Encoder systems for motors with DRIVE-CLiQ interface:	Multi-pole resolver	D F L K V U P
	2-pole resolver	
	IC22DQ encoder	
	AM22DQ encoder (from shaft height 48)	
	AM20DQ encoder (shaft height 36 only)	
Holding brake:	Motor <u>without</u> holding brake	U V
	Motor <u>with</u> holding brake	

Order codes for type/
gear shaft extension and type of
construction/mounting position/
connector mounting position,
see page 4/86.

Servomotors

Geared servomotors for SINAMICS S120

1FK7 bevel geared motors

Selection and ordering data

Power at duty type S3-60 %	Output speed at the gear shaft	Rated output torque gearbox at duty type S3-60 %	Acceleration torque, max. gearbox	Nominal ratio	Exact ratio	Cantilever force, perm., gear shaft extension	Overload factor
P_2	n_2	M_2	M_{2max}	i_{nom}	i_{exact}	F_{Tperm}	f_B
kW (HP)	rpm	Nm (lb _f -ft)	Nm (lb _f -ft)			N (lb _f)	
Natural cooling – SH 63/SH 80/SH 100							
2.22 (2.98)	750	28.3 (20.9)	76 (56.1)	4	4/1	1494 (336)	1.8
	750	28.3 (20.9)	83 (61.2)	4	4/1	1793 (403)	2.0
	500	42.5 (31.3)	87 (64.2)	6	6/1	1710 (384)	1.4
	500	42.5 (31.3)	128 (94.4)	6	6/1	2394 (538)	2.0
	324	65.6 (48.4)	186 (137)	9.3	1075/116	2767 (622)	1.9
	178	119 (87.8)	219 (162)	17	2967/176	2895 (651)	1.2
	129	165 (122)	385 (284)	23	559/24	3762 (846)	1.5
	86	246 (181)	385 (284)	35	903/26	4298 (966)	1.0
	65	328 (242)	600 (443)	46	602/13	7570 (1702)	1.2
2.17 (2.91)	46	450 (332)	1000 (738)	65	12586/195	10154 (2283)	1.5
2.07 (2.78)	750	26.4 (19.5)	135 (99.6)	4	4/1	1793 (403)	4.4
	500	39.6 (29.2)	155 (114)	6	6/1	2052 (461)	3.3
	298	66.4 (49.0)	184 (136)	10	2881/286	2439 (548)	2.4
	177	112 (82.6)	384 (283)	17	559/33	3383 (761)	2.9
	129	153 (113)	220 (162)	23	2967/128	3220 (724)	1.2
	129	154 (114)	385 (284)	23	559/24	3762 (846)	2.1
	86	229 (169)	600 (443)	35	4171/120	6879 (1546)	2.2
2.03 (2.72)	62	313 (231)	1000 (738)	48	2697/56	9210 (2071)	2.7
	39	495 (365)	1600 (1180)	76	126697/1664	12763 (2869)	2.7
3.20 (4.29)	750	40.7 (30.0)	135 (99.6)	4	4/1	1793 (403)	2.2
	500	61.1 (45.1)	155 (114)	6	6/1	2052 (461)	1.7
	500	61.1 (45.1)	271 (200)	6	6/1	2394 (538)	2.9
	298	103 (76.0)	184 (136)	10	2881/286	2439 (548)	1.2
	324	94.4 (69.6)	314 (232)	9.3	1075/116	2767 (622)	2.2
	177	173 (128)	384 (283)	17	559/33	3383 (761)	1.5
	177	173 (128)	575 (424)	17	559/33	5414 (1217)	2.2
	129	237 (175)	385 (284)	23	559/24	3762 (846)	1.1
3.14 (4.21)	123	244 (180)	1000 (738)	24	11687/480	7337 (1649)	2.7
	93	324 (239)	1000 (738)	32	20677/640	8062 (1812)	2.0
	62	483 (356)	1000 (738)	48	2697/56	9210 (2071)	1.4
	63	479 (353)	1600 (1180)	48	39711/832	10923 (2456)	2.2
	46	648 (478)	1000 (738)	65	12586/195	10154 (2283)	1.0
	46	651 (480)	2574 (1899)	65	33201/512	16635 (3740)	2.6
3.19 (4.28)	86	354 (261)	600 (443)	35	4171/120	6879 (1546)	1.1
3.66 (4.91)	750	46.6 (34.4)	356 (263)	4	4/1	3346 (752)	5.1
	500	69.8 (51.5)	407 (300)	6	6/1	3830 (861)	3.9
	297	118 (87.0)	484 (357)	10	1333/132	4556 (1024)	2.7
	177	197 (145)	575 (424)	17	559/33	5414 (1217)	1.9
	129	271 (200)	600 (443)	23	559/24	6020 (1353)	1.5
3.60 (4.83)	123	279 (206)	1000 (738)	24	11687/480	7337 (1649)	2.4
	93	371 (274)	1000 (738)	32	20677/640	8062 (1812)	1.8
	87	397 (293)	1600 (1180)	35	35441/1024	9813 (2206)	2.7
	60	572 (422)	2600 (1918)	50	166005/3328	15242 (3427)	3.0
	46	744 (549)	2600 (1918)	65	33201/512	16635 (3740)	2.3

Servomotors

Geared servomotors for SINAMICS S120

1FK7 bevel geared motors

Gearbox size	Motor shaft height	1FK7 bevel geared motors				Gearbox weight, approx. kg (lb)
		Order No.	Order codes	Type/gear shaft extension	Type of construction/ mounting position/ connector mounting position	
	SH					
K102	63	1FK7063-5AF71-1 ■■■ 5-Z	B11	G . .	H . .	20.8 (45.9)
K202	63	1FK7063-5AF71-1 ■■■ 5-Z	B21	G . .	H . .	28.3 (62.4)
K102	63	1FK7063-5AF71-1 ■■■ 5-Z	B12	G . .	H . .	20.8 (45.9)
K302	63	1FK7063-5AF71-1 ■■■ 5-Z	B32	G . .	H . .	33.3 (73.4)
K302	63	1FK7063-5AF71-1 ■■■ 5-Z	B33	G . .	H . .	33.3 (73.4)
K202	63	1FK7063-5AF71-1 ■■■ 5-Z	B24	G . .	H . .	28.3 (62.4)
K302	63	1FK7063-5AF71-1 ■■■ 5-Z	B35	G . .	H . .	33.3 (73.4)
K302	63	1FK7063-5AF71-1 ■■■ 5-Z	B36	G . .	H . .	33.3 (73.4)
K402	63	1FK7063-5AF71-1 ■■■ 5-Z	B47	G . .	H . .	46.8 (103)
K513	63	1FK7063-5AF71-1 ■■■ 5-Z	B58	G . .	H . .	52.6 (116)
K202	80	1FK7080-5AF71-1 ■■■ 5-Z	B21	G . .	H . .	28.0 (61.7)
K202	80	1FK7080-5AF71-1 ■■■ 5-Z	B22	G . .	H . .	28.0 (61.7)
K202	80	1FK7080-5AF71-1 ■■■ 5-Z	B23	G . .	H . .	28.0 (61.7)
K302	80	1FK7080-5AF71-1 ■■■ 5-Z	B34	G . .	H . .	33.0 (72.8)
K202	80	1FK7080-5AF71-1 ■■■ 5-Z	B25	G . .	H . .	28.0 (61.7)
K302	80	1FK7080-5AF71-1 ■■■ 5-Z	B35	G . .	H . .	33.0 (72.8)
K402	80	1FK7080-5AF71-1 ■■■ 5-Z	B46	G . .	H . .	46.5 (103)
K513	80	1FK7080-5AF71-1 ■■■ 5-Z	B57	G . .	H . .	52.3 (115)
K613	80	1FK7080-5AF71-1 ■■■ 5-Z	B68	G . .	H . .	73.8 (163)
K202	80	1FK7083-5AF71-1 ■■■ 5-Z	B21	G . .	H . .	33.2 (73.2)
K202	80	1FK7083-5AF71-1 ■■■ 5-Z	B22	G . .	H . .	33.2 (73.2)
K302	80	1FK7083-5AF71-1 ■■■ 5-Z	B32	G . .	H . .	38.2 (84.2)
K202	80	1FK7083-5AF71-1 ■■■ 5-Z	B23	G . .	H . .	33.2 (73.2)
K302	80	1FK7083-5AF71-1 ■■■ 5-Z	B33	G . .	H . .	38.2 (84.2)
K302	80	1FK7083-5AF71-1 ■■■ 5-Z	B34	G . .	H . .	38.2 (84.2)
K402	80	1FK7083-5AF71-1 ■■■ 5-Z	B44	G . .	H . .	51.7 (114)
K302	80	1FK7083-5AF71-1 ■■■ 5-Z	B35	G . .	H . .	38.2 (84.2)
K513	80	1FK7083-5AF71-1 ■■■ 5-Z	B55	G . .	H . .	57.5 (127)
K513	80	1FK7083-5AF71-1 ■■■ 5-Z	B56	G . .	H . .	57.5 (127)
K513	80	1FK7083-5AF71-1 ■■■ 5-Z	B57	G . .	H . .	57.5 (127)
K613	80	1FK7083-5AF71-1 ■■■ 5-Z	B67	G . .	H . .	79.0 (174)
K513	80	1FK7083-5AF71-1 ■■■ 5-Z	B58	G . .	H . .	57.5 (127)
K713	80	1FK7083-5AF71-1 ■■■ 5-Z	B78	G . .	H . .	107.3 (237)
K402	80	1FK7083-5AF71-1 ■■■ 5-Z	B46	G . .	H . .	51.7 (114)
K402	100	1FK7100-5AF71-1 ■■■ 5-Z	B41	G . .	H . .	53.9 (119)
K402	100	1FK7100-5AF71-1 ■■■ 5-Z	B42	G . .	H . .	53.9 (119)
K402	100	1FK7100-5AF71-1 ■■■ 5-Z	B43	G . .	H . .	53.9 (119)
K402	100	1FK7100-5AF71-1 ■■■ 5-Z	B44	G . .	H . .	53.9 (119)
K402	100	1FK7100-5AF71-1 ■■■ 5-Z	B45	G . .	H . .	53.9 (119)
K513	100	1FK7100-5AF71-1 ■■■ 5-Z	B55	G . .	H . .	59.7 (132)
K513	100	1FK7100-5AF71-1 ■■■ 5-Z	B56	G . .	H . .	59.7 (132)
K613	100	1FK7100-5AF71-1 ■■■ 5-Z	B66	G . .	H . .	81.2 (179)
K713	100	1FK7100-5AF71-1 ■■■ 5-Z	B77	G . .	H . .	109.5 (241)
K713	100	1FK7100-5AF71-1 ■■■ 5-Z	B78	G . .	H . .	109.5 (241)

Encoder systems for motors without DRIVE-CLiQ interface: IC2048S/R encoder
AM2048S/R encoder
AM32S/R encoder
Multi-pole resolver
2-pole resolver

Encoder systems for motors with DRIVE-CLiQ interface: IC22DQ encoder
AM22DQ encoder
AM16DQ encoder
R15DQ resolver
R14DQ resolver

Holding brake: Motor without holding brake
Motor with holding brake

A
E
G
S
T

D
F
K
U
P

U
V

Order codes for type/
gear shaft extension and type of
construction/mounting position/
connector mounting position,
see page 4/86.

Servomotors

Geared servomotors for SINAMICS S120

1FK7 bevel geared motors

Selection and ordering data

Power at duty type S3-60 %	Output speed at the gear shaft	Rated output torque gearbox at duty type S3-60 %	Acceleration torque, max. gearbox	Nominal ratio	Exact ratio	Cantilever force, perm., gear shaft extension	Overload factor
P_2	n_2	M_2	M_{2max}	i_{nom}	i_{exact}	F_{Tperm}	f_B
kW (HP)	rpm	Nm (lb _F -ft)	Nm (lb _F -ft)			N (lb _F)	
Natural cooling – SH 100							
4.72 (6.33)	750	60.1 (44.3)	356 (263)	4	4/1	3346 (752)	3.4
	500	90.2 (66.5)	407 (300)	6	6/1	3830 (861)	2.6
	297	152 (112)	484 (357)	10	1333/132	4556 (1024)	1.8
	177	255 (188)	575 (424)	17	559/33	5414 (1217)	1.3
4.66 (6.25)	186	238 (176)	1000 (738)	16	26071/1620	6391 (1437)	2.4
	123	361 (266)	1000 (738)	24	11687/480	7337 (1649)	1.6
	125	356 (263)	1584 (1168)	24	24583/1024	8687 (1953)	2.6
	87	513 (378)	1600 (1180)	35	35441/1024	9813 (2206)	1.8
	85	525 (387)	2600 (1918)	35	567/16	13600 (3057)	2.8
4.64 (6.22)	60	739 (545)	2600 (1918)	50	166005/3328	15242 (3427)	2.0
4.63 (6.21)	46	961 (709)	2600 (1918)	65	33201/512	16635 (3740)	1.6
4.67 (6.26)	46	969 (714)	4650 (3430)	65	188387/2880	21991 (4944)	2.8
5.17 (6.93)	625	79 (58.3)	356 (263)	4	4/1	3346 (752)	2.5
5.20 (6.97)	417	119 (87.8)	407 (300)	6	6/1	3830 (861)	1.9
5.19 (6.96)	248	200 (148)	484 (357)	10	1333/132	4556 (1024)	1.4
5.13 (6.88)	246	199 (147)	900 (664)	10	203/20	5481 (1232)	2.6
	155	315 (232)	1000 (738)	16	26071/1620	6391 (1437)	1.8
	158	310 (229)	1380 (1018)	16	54839/3456	7567 (1701)	2.5
	103	477 (352)	1000 (738)	24	11687/480	7337 (1649)	1.2
	104	470 (347)	1584 (1168)	24	24583/1024	8687 (1953)	1.9
	72	678 (500)	1600 (1180)	35	35441/1024	9813 (2206)	1.3
5.16 (6.92)	71	694 (512)	2600 (1918)	35	567/16	13600 (3057)	2.1
5.12 (6.87)	50	978 (721)	2600 (1918)	50	166005/3328	15242 (3427)	1.5
5.13 (6.88)	51	960 (708)	4650 (3430)	49	5487/112	19971 (4490)	2.8
5.19 (6.96)	39	1271 (938)	2600 (1918)	65	33201/512	16635 (3740)	1.2
5.09 (6.83)	38	1280 (944)	4650 (3430)	65	188387/2880	21991 (4944)	2.1
7.93 (10.6)	750	101 (74.5)	356 (263)	4	4/1	3346 (752)	1.9
	500	151 (111)	407 (300)	6	6/1	3830 (861)	1.5
7.81 (10.5)	296	252 (186)	900 (664)	10	203/20	5481 (1232)	1.9
7.93 (10.6)	297	255 (188)	484 (357)	10	1333/132	4556 (1024)	1.0
7.80 (10.5)	189	394 (291)	1380 (1018)	16	54839/3456	7567 (1701)	1.9
	186	400 (295)	1000 (738)	16	26071/1620	6391 (1437)	1.4
	125	597 (440)	1584 (1168)	24	24583/1024	8687 (1953)	1.4
	119	626 (462)	2600 (1918)	25	64449/2560	12135 (2728)	2.3
7.84 (10.5)	85	881 (650)	2600 (1918)	35	567/16	3276 (736)	1.6
7.80 (10.5)	83	898 (662)	4255 (3139)	36	2891/80	18045 (4057)	2.6
	61	1218 (898)	4650 (3430)	49	5487/112	19971 (4490)	2.1
	60	1240 (915)	2600 (1918)	50	166005/3328	15242 (3427)	1.1
7.83 (10.5)	46	1626 (1199)	4650 (3430)	65	188387/2880	21991 (4944)	1.5

Servomotors

Geared servomotors for SINAMICS S120

1FK7 bevel geared motors

Gearbox size	Motor shaft height	1FK7 bevel geared motors				Gearbox weight, approx. kg (lb)
		Order No.	Order codes	Type/gear shaft extension	Type of construction/ mounting position/ connector mounting position	
K402	100	1FK7101-5AF71-1 ■ ■ ■ 5 - Z	B41	G . .	H . .	59.5 (131)
K402	100	1FK7101-5AF71-1 ■ ■ ■ 5 - Z	B42	G . .	H . .	59.5 (131)
K402	100	1FK7101-5AF71-1 ■ ■ ■ 5 - Z	B43	G . .	H . .	59.5 (131)
K402	100	1FK7101-5AF71-1 ■ ■ ■ 5 - Z	B44	G . .	H . .	59.5 (131)
K513	100	1FK7101-5AF71-1 ■ ■ ■ 5 - Z	B54	G . .	H . .	65.3 (144)
K513	100	1FK7101-5AF71-1 ■ ■ ■ 5 - Z	B55	G . .	H . .	65.3 (144)
K613	100	1FK7101-5AF71-1 ■ ■ ■ 5 - Z	B65	G . .	H . .	86.8 (191)
K613	100	1FK7101-5AF71-1 ■ ■ ■ 5 - Z	B66	G . .	H . .	86.8 (191)
K713	100	1FK7101-5AF71-1 ■ ■ ■ 5 - Z	B76	G . .	H . .	115.1 (254)
K713	100	1FK7101-5AF71-1 ■ ■ ■ 5 - Z	B77	G . .	H . .	115.1 (254)
K713	100	1FK7101-5AF71-1 ■ ■ ■ 5 - Z	B78	G . .	H . .	115.1 (254)
K813	100	1FK7101-5AF71-1 ■ ■ ■ 5 - Z	B88	G . .	H . .	168.5 (372)
K402	100	1FK7103-5AF71-1 ■ ■ ■ 5 - Z	B41	G . .	H . .	66.1 (146)
K402	100	1FK7103-5AF71-1 ■ ■ ■ 5 - Z	B42	G . .	H . .	66.1 (146)
K402	100	1FK7103-5AF71-1 ■ ■ ■ 5 - Z	B43	G . .	H . .	66.1 (146)
K513	100	1FK7103-5AF71-1 ■ ■ ■ 5 - Z	B53	G . .	H . .	71.9 (159)
K513	100	1FK7103-5AF71-1 ■ ■ ■ 5 - Z	B54	G . .	H . .	71.9 (159)
K613	100	1FK7103-5AF71-1 ■ ■ ■ 5 - Z	B64	G . .	H . .	93.4 (206)
K513	100	1FK7103-5AF71-1 ■ ■ ■ 5 - Z	B55	G . .	H . .	71.9 (159)
K613	100	1FK7103-5AF71-1 ■ ■ ■ 5 - Z	B65	G . .	H . .	93.4 (206)
K613	100	1FK7103-5AF71-1 ■ ■ ■ 5 - Z	B66	G . .	H . .	93.4 (206)
K713	100	1FK7103-5AF71-1 ■ ■ ■ 5 - Z	B76	G . .	H . .	121.7 (268)
K713	100	1FK7103-5AF71-1 ■ ■ ■ 5 - Z	B77	G . .	H . .	121.7 (268)
K813	100	1FK7103-5AF71-1 ■ ■ ■ 5 - Z	B87	G . .	H . .	175.1 (386)
K713	100	1FK7103-5AF71-1 ■ ■ ■ 5 - Z	B78	G . .	H . .	121.7 (268)
K813	100	1FK7103-5AF71-1 ■ ■ ■ 5 - Z	B88	G . .	H . .	175.1 (386)
K402	100	1FK7105-5AF71-1 ■ ■ ■ 5 - Z	B41	G . .	H . .	76.1 (168)
K402	100	1FK7105-5AF71-1 ■ ■ ■ 5 - Z	B42	G . .	H . .	76.1 (168)
K513	100	1FK7105-5AF71-1 ■ ■ ■ 5 - Z	B53	G . .	H . .	82.0 (181)
K402	100	1FK7105-5AF71-1 ■ ■ ■ 5 - Z	B43	G . .	H . .	76.1 (168)
K613	100	1FK7105-5AF71-1 ■ ■ ■ 5 - Z	B64	G . .	H . .	103 (227)
K513	100	1FK7105-5AF71-1 ■ ■ ■ 5 - Z	B54	G . .	H . .	82.0 (181)
K613	100	1FK7105-5AF71-1 ■ ■ ■ 5 - Z	B65	G . .	H . .	103 (227)
K713	100	1FK7105-5AF71-1 ■ ■ ■ 5 - Z	B75	G . .	H . .	132 (291)
K713	100	1FK7105-5AF71-1 ■ ■ ■ 5 - Z	B76	G . .	H . .	132 (291)
K813	100	1FK7105-5AF71-1 ■ ■ ■ 5 - Z	B86	G . .	H . .	185 (408)
K813	100	1FK7105-5AF71-1 ■ ■ ■ 5 - Z	B87	G . .	H . .	185 (408)
K713	100	1FK7105-5AF71-1 ■ ■ ■ 5 - Z	B77	G . .	H . .	132 (291)
K813	100	1FK7105-5AF71-1 ■ ■ ■ 5 - Z	B88	G . .	H . .	185 (408)

Encoder systems for motors without DRIVE-CLiQ interface:	IC2048S/R encoder AM2048S/R encoder AM32S/R encoder Multi-pole resolver 2-pole resolver	A E G S T
Encoder systems for motors with DRIVE-CLiQ interface:	IC22DQ encoder AM22DQ encoder AM16DQ encoder R15DQ resolver R14DQ resolver	D F K U P
Holding brake:	Motor <u>without</u> holding brake Motor <u>with</u> holding brake	U V

Order codes for type/
gear shaft extension and type of
construction/mounting position/
connector mounting position,
see page 4/86.

Servomotors

Geared servomotors for SINAMICS S120

1FK7 worm geared motors

Selection and ordering data

Power at duty type S3-60 %	Output speed at the gear shaft	Rated output torque gearbox at duty type S3-60 %	Acceleration torque, max. gearbox	Nominal ratio	Exact ratio	Cantilever force, perm., gear shaft extension	Overload factor
P_2	n_2	M_2	M_{2max}	i_{nom}	i_{exact}	F_{rperm}	f_B
kW (HP)	rpm	Nm (lb _f -ft)	Nm (lb _f -ft)			N (lb _f)	
Natural cooling – SH 36/SH 48/SH 63							
0.28 (0.38)	312	8.5 (6.27)	43 (31.7)	9.6	1107/115	1689 (380)	4.1
	172	15.3 (11.3)	73 (53.8)	17.5	297/17	1938 (436)	3.9
0.27 (0.36)	128	20.2 (14.9)	82 (60.5)	23	117/5	2271 (511)	3.3
	86	30.0 (22.1)	125 (92.2)	35	873/25	2441 (549)	3.4
0.24 (0.32)	51	45.6 (33.6)	88 (64.9)	59	117/2	3082 (693)	1.6
	52	45.8 (33.8)	172 (126.9)	58	405/7	2889 (649)	3.1
	40	57.7 (42.6)	96 (70.8)	75	747/10	3343 (752)	1.4
0.38 (0.51)	43	54.8 (40.4)	184 (136)	70	279/4	3075 (691)	2.7
	172	21.2 (15.6)	110 (81.1)	17.5	297/17	1938 (436)	4.4
0.35 (0.47)	86	41.6 (30.7)	150 (111)	35	873/25	2441 (549)	3.0
	52	63.4 (46.8)	172 (127)	58	405/7	2889 (649)	2.3
0.73 (0.98)	43	75.9 (56.0)	184 (136)	70	279/4	3075 (691)	2.0
	172	40.8 (30.1)	110 (81.1)	17.5	297/17	1938 (436)	2.3
0.72 (0.97)	130	53.6 (39.5)	132 (97.4)	23	162/7	2128 (478)	2.1
	86	80.1 (59.1)	150 (111)	35	873/25	2441 (549)	1.6
0.66 (0.89)	86	79.9 (58.9)	252 (186)	35	243/7	3411 (767)	2.7
	52	122 (90.0)	172 (127)	58	405/7	2889 (649)	1.2
0.69 (0.93)	52	126 (92.9)	302 (223)	58	1863/32	4053 (911)	2.1
0.66 (0.89)	43	146 (108)	184 (136)	70	279/4	3075 (691)	1.1
0.68 (0.91)	43	151 (111)	324 (239)	70	351/5	4314 (970)	1.9
1.35 (1.81)	326	39.5 (29.1)	74 (54.6)	9.2	46/5	1565 (352)	1.5
1.33 (1.78)	172	73.7 (54.4)	110 (81.1)	17.5	297/17	1938 (436)	1.2
	171	74.4 (54.9)	217 (160)	17.5	351/20	2717 (611)	2.3
1.31 (1.76)	129	97.9 (72.2)	259 (191)	23	1863/80	2986 (671)	2.1
	86	144 (106)	310 (229)	35	243/7	3411 (767)	1.7
	86	146 (108)	498 (367)	35	2268/65	4881 (1097)	2.7
1.24 (1.66)	52	227 (167)	302 (233)	58	1863/32	4053 (911)	1.0
	51	232 (171)	561 (414)	59	117/2	5799 (1304)	1.9
	43	275 (203)	609 (449)	70	2241/32	6157 (1384)	1.7
	43	277 (204)	791 (583)	70	279/4	7994 (1797)	2.2

Servomotors

Geared servomotors for SINAMICS S120

1FK7 worm geared motors

Gearbox size	Motor shaft height	1FK7 worm geared motors				Gearbox weight, approx. kg (lb)
		Order No.	Order codes	Gearbox type	Type/gear shaft extension Type of construction/ mounting position/ connector mounting position	
S002	36	1FK7032-5AK71-1 ■■■ 5-Z	E03	G . .	H . .	6.6 (14.6)
S102	36	1FK7032-5AK71-1 ■■■ 5-Z	E14	G . .	H . .	12.9 (28.4)
S002	36	1FK7032-5AK71-1 ■■■ 5-Z	E05	G . .	H . .	6.6 (14.6)
S102	36	1FK7032-5AK71-1 ■■■ 5-Z	E16	G . .	H . .	12.9 (28.4)
S002	36	1FK7032-5AK71-1 ■■■ 5-Z	E07	G . .	H . .	6.6 (14.6)
S102	36	1FK7032-5AK71-1 ■■■ 5-Z	E17	G . .	H . .	12.9 (28.4)
S002	36	1FK7032-5AK71-1 ■■■ 5-Z	E08	G . .	H . .	6.6 (14.6)
S102	36	1FK7032-5AK71-1 ■■■ 5-Z	E18	G . .	H . .	12.9 (28.4)
S102	48	1FK7040-5AK71-1 ■■■ 5-Z	E14	G . .	H . .	13.7 (30.2)
S102	48	1FK7040-5AK71-1 ■■■ 5-Z	E16	G . .	H . .	13.7 (30.2)
S102	48	1FK7040-5AK71-1 ■■■ 5-Z	E17	G . .	H . .	13.7 (30.2)
S102	48	1FK7040-5AK71-1 ■■■ 5-Z	E18	G . .	H . .	13.7 (30.2)
S102	48	1FK7042-5AF71-1 ■■■ 5-Z	E14	G . .	H . .	15.0 (33.1)
S102	48	1FK7042-5AF71-1 ■■■ 5-Z	E15	G . .	H . .	15.0 (33.1)
S102	48	1FK7042-5AF71-1 ■■■ 5-Z	E16	G . .	H . .	15.0 (33.1)
S202	48	1FK7042-5AF71-1 ■■■ 5-Z	E26	G . .	H . .	22.5 (49.6)
S102	48	1FK7042-5AF71-1 ■■■ 5-Z	E17	G . .	H . .	15.0 (33.1)
S202	48	1FK7042-5AF71-1 ■■■ 5-Z	E27	G . .	H . .	22.5 (49.6)
S102	48	1FK7042-5AF71-1 ■■■ 5-Z	E18	G . .	H . .	15.0 (33.1)
S202	48	1FK7042-5AF71-1 ■■■ 5-Z	E28	G . .	H . .	22.5 (49.6)
S102	63	1FK7060-5AF71-1 ■■■ 5-Z	E13	G . .	H . .	17.7 (39.0)
S102	63	1FK7060-5AF71-1 ■■■ 5-Z	E14	G . .	H . .	17.7 (39.0)
S202	63	1FK7060-5AF71-1 ■■■ 5-Z	E24	G . .	H . .	25.2 (55.6)
S202	63	1FK7060-5AF71-1 ■■■ 5-Z	E25	G . .	H . .	25.2 (55.6)
S202	63	1FK7060-5AF71-1 ■■■ 5-Z	E26	G . .	H . .	25.2 (55.6)
S302	63	1FK7060-5AF71-1 ■■■ 5-Z	E36	G . .	H . .	34.4 (75.9)
S202	63	1FK7060-5AF71-1 ■■■ 5-Z	E27	G . .	H . .	25.2 (55.6)
S302	63	1FK7060-5AF71-1 ■■■ 5-Z	E37	G . .	H . .	34.4 (75.9)
S302	63	1FK7060-5AF71-1 ■■■ 5-Z	E38	G . .	H . .	34.4 (75.9)
S402	63	1FK7060-5AF71-1 ■■■ 5-Z	E48	G . .	H . .	43.6 (96.1)

Encoder systems for motors without DRIVE-CLiQ interface:	IC2048S/R encoder	A
	AM2048S/R encoder (from shaft height 48)	E
	AM512S/R encoder (shaft height 36 only)	H
	AM32S/R encoder (from shaft height 48)	G
	AM16S/R encoder (shaft height 36 only)	J
	Multi-pole resolver	S
2-pole resolver	T	
Encoder systems for motors with DRIVE-CLiQ interface:	IC22DQ encoder	D
	AM22DQ encoder (from shaft height 48)	F
	AM20DQ encoder (shaft height 36 only)	L
	AM16DQ encoder (from shaft height 48)	K
	AM15DQ encoder (shaft height 36 only)	V
	R15DQ resolver	U
	R14DQ resolver	P
Holding brake:	Motor <u>without</u> holding brake	U
	Motor <u>with</u> holding brake	V

Order codes for type/
gear shaft extension and type of
construction/mounting position/
connector mounting position,
see page 4/86.

Servomotors

Geared servomotors for SINAMICS S120

1FK7 worm geared motors

Selection and ordering data

Power at duty type S3-60 %	Output speed at the gear shaft	Rated output torque gearbox at duty type S3-60 %	Acceleration torque, max. gearbox	Nominal ratio	Exact ratio	Cantilever force, perm., gear shaft extension	Overload factor
P_2 kW (HP)	n_2 rpm	M_2 Nm (lb _f -ft)	M_{2max} Nm (lb _f -ft)	i_{nom}	i_{exact}	F_{Tperm} N (lb _f)	f_B
Natural cooling – SH 63/SH 80/SH 100							
2.11 (2.83)	325	61.9 (45.7)	126 (92.9)	9.2	1431/155	2194 (493)	1.4
2.08 (2.79)	171	116 (85.6)	217 (160)	17.5	351/20	2717 (611)	1.2
2.05 (2.75)	129	152 (112)	259 (191)	23	1863/80	2986 (671)	1.1
	86	227 (167)	498 (367)	35	2268/65	4881 (1097)	1.5
1.92 (2.57)	51	360 (266)	561 (414)	59	117/2	5799 (1304)	1.0
1.94 (2.60)	43	430 (317)	791 (583)	70	279/4	7994 (1797)	1.2
1.93 (2.59)	171	108 (79.7)	217 (160)	17.5	351/20	2717 (611)	1.7
	173	107 (78.9)	373 (275)	17.5	1998/115	3869 (870)	3.0
	129	142 (105)	259 (191)	23	1863/80	2986 (671)	1.6
	128	144 (106)	458 (338)	23	117/5	4273 (961)	2.7
1.79 (2.40)	86	213 (157)	720 (531)	35	873/25	6347 (1427)	2.9
	51	335 (247)	561 (414)	59	117/2	5799 (1304)	1.4
1.79 (2.40)	43	399 (294)	609 (449)	70	2241/32	6157 (1384)	1.3
3.05 (4.09)	322	90.5 (66.8)	216 (159)	9.3	270/29	3143 (707)	1.6
3.01 (4.04)	173	166 (122)	373 (275)	17.5	1998/115	3869 (870)	1.5
3.03 (4.06)	172	168 (124)	557 (411)	17.5	612/35	5040 (1133)	2.2
2.98 (4.00)	128	222 (164)	458 (338)	23	117/5	4273 (961)	1.4
	128	222 (164)	685 (505)	23	117/5	5554 (1249)	2.0
2.95 (3.96)	86	328 (242)	720 (531)	35	873/25	6347 (1427)	1.4
3.47 (4.65)	259	128 (94.4)	371 (274)	11.5	81/7	4392 (987)	1.9
3.44 (4.61)	172	191 (141)	557 (411)	17.5	612/35	5040 (1133)	1.9
4.50 (6.03)	259	166 (122)	371 (274)	11.5	81/7	4392 (987)	1.3
4.45 (5.97)	172	247 (182)	557 (411)	17.5	612/35	5040 (1133)	1.3

Servomotors

Geared servomotors for SINAMICS S120

1FK7 worm geared motors

Gearbox size	Motor shaft height	1FK7 worm geared motors				Gearbox weight, approx. kg (lb)
		Order No.	Order codes	Gearbox type	Type/gear shaft extension Type of construction/ mounting position/ connector mounting position	
S202	63	1FK7063-5AF71-1 ■■■ 5-Z	E23	G . .	H . .	28.9 (63.7)
S202	63	1FK7063-5AF71-1 ■■■ 5-Z	E24	G . .	H . .	28.9 (63.7)
S202	63	1FK7063-5AF71-1 ■■■ 5-Z	E25	G . .	H . .	28.9 (63.7)
S302	63	1FK7063-5AF71-1 ■■■ 5-Z	E36	G . .	H . .	38.1 (84.0)
S302	63	1FK7063-5AF71-1 ■■■ 5-Z	E37	G . .	H . .	38.1 (84.0)
S402	63	1FK7063-5AF71-1 ■■■ 5-Z	E48	G . .	H . .	47.3 (104)
S202	80	1FK7080-5AF71-1 ■■■ 5-Z	E24	G . .	H . .	28.6 (63.1)
S302	80	1FK7080-5AF71-1 ■■■ 5-Z	E34	G . .	H . .	37.8 (83.4)
S202	80	1FK7080-5AF71-1 ■■■ 5-Z	E25	G . .	H . .	28.6 (63.1)
S302	80	1FK7080-5AF71-1 ■■■ 5-Z	E35	G . .	H . .	37.8 (83.4)
S402	80	1FK7080-5AF71-1 ■■■ 5-Z	E46	G . .	H . .	47 (104)
S302	80	1FK7080-5AF71-1 ■■■ 5-Z	E37	G . .	H . .	37.8 (83.4)
S302	80	1FK7080-5AF71-1 ■■■ 5-Z	E38	G . .	H . .	37.8 (83.4)
S302	80	1FK7083-5AF71-1 ■■■ 5-Z	E33	G . .	H . .	43 (94.8)
S302	80	1FK7083-5AF71-1 ■■■ 5-Z	E34	G . .	H . .	43 (94.8)
S402	80	1FK7083-5AF71-1 ■■■ 5-Z	E44	G . .	H . .	52.2 (115)
S302	80	1FK7083-5AF71-1 ■■■ 5-Z	E35	G . .	H . .	43 (94.8)
S402	80	1FK7083-5AF71-1 ■■■ 5-Z	E45	G . .	H . .	52.2 (115)
S402	80	1FK7083-5AF71-1 ■■■ 5-Z	E46	G . .	H . .	52.2 (115)
S402	100	1FK7100-5AF71-1 ■■■ 5-Z	E43	G . .	H . .	54.4 (120)
S402	100	1FK7100-5AF71-1 ■■■ 5-Z	E44	G . .	H . .	54.4 (120)
S402	100	1FK7101-5AF71-1 ■■■ 5-Z	E43	G . .	H . .	60 (132)
S402	100	1FK7101-5AF71-1 ■■■ 5-Z	E44	G . .	H . .	60 (132)
Encoder systems for motors without DRIVE-CLiQ interface:	IC2048S/R encoder AM2048S/R encoder AM32S/R encoder Multi-pole resolver 2-pole resolver	A E G S T				
Encoder systems for motors with DRIVE-CLiQ interface:	IC22DQ encoder AM22DQ encoder AM16DQ encoder R15DQ resolver R14DQ resolver	D F K U P				
Holding brake:	Motor without holding brake Motor <u>with</u> holding brake	U V				

Order codes for type/
gear shaft extension and type of
construction/mounting position/
connector mounting position,
see page 4/86.

Servomotors

Geared servomotors for SINAMICS S120

1FK7 geared servomotors

Order No. supplements – Order codes

When ordering a geared servomotor with options, **-Z** should be added to the order number. The order code should also be specified for each additional required option. The description of the option must not be repeated in plain text in the order.

1st Order code: Gearbox type

- Bevel gearbox K102 to K813
- Offset-shaft gearbox F202 to F602
- Helical gearbox C002 to C812
- Worm gearbox S002 to S402

B..
C..
D..
E..

[Complete order code for gearbox type, refer to selection and ordering data](#)

2nd order code, 1st and 2nd positions: Type

- Foot-mounted
- Tapped hole group
- Flange (round)
- Foot-mounted and flange (round)
- Foot-mounted and tapped hole group

G 1 ■
G 2 ■
G 3 ■
G 5 ■
G 6 ■

2. order code, 3rd position: Gear shaft extension

Helical gearbox:

- Solid shaft with fitted key

Offset-shaft gearbox:

- Solid shaft with fitted key, gearbox side 5
- Hollow shaft with keyway, insertion side 5
- Hollow shaft with clamping element, shrink disk side 6, insertion side 5

Bevel and worm gearboxes:

- Solid shaft with fitted key, gearbox side 4
- Hollow shaft with keyway, insertion side 4
- Hollow shaft with clamping element, shrink disk side 4, insertion side 3
- Solid shaft with fitted key, gearbox side 3
- Hollow shaft with keyway, insertion side 3
- Hollow shaft with clamping element, shrink disk side 3, insertion side 4

1
3
4
5
7
8

3rd order code, 1st and 2nd positions: Type of construction/mounting position

Type of construction for helical gearboxes:

- IM B3 / IM B5 / IM B14 / IM B34 / IM B35
- IM B7
- IM B8
- IM B6
- IM V1
- IM V3 / IM V6 / IM V19
- IM V5
- IM V18

Mounting position for offset-shaft, bevel and worm gearboxes:

- EL 1
- EL 2
- EL 3
- EL 4
- EL 5
- EL 6
-
-

H 1 ■
H 2 ■
H 3 ■
H 4 ■
H 5 ■
H 6 ■
H 7 ■
H 8 ■

3rd order code, 3rd position: Connector mounting position

- Connector position on gearbox side 2, top
- Connector position on gearbox side 4, right
- Connector position on gearbox side 1, below
- Connector position on gearbox side 3, left

1
2
3
4

For a diagram of the connector mounting position, see page 4/88.

Order No. supplements – Order codes

Permissible combinations for option Q.. with G2.

4th Order code: Torque bracket for bevel and worm gearboxes

<u>Torque bracket position</u>	<u>Gearbox type and size</u>			
Side 1, eye side 4	K102/S102	Q12	and	G23 or G28
Side 1, eye side 3	K102/S102	Q13		G27 or G24
Side 5, eye side 4	K102/S102	Q14		G23 or G28
Side 5, eye side 3	K102/S102	Q15		G27 or G24
Side 2, eye side 4	K102	Q16		G23 or G28
Side 2, eye side 3	K102	Q17		G27 or G24
Side 1, eye side 4	K202/S202	Q22		G23 or G28
Side 1, eye side 3	K202/S202	Q23		G27 or G24
Side 5, eye side 4	K202/S202	Q24		G23 or G28
Side 5, eye side 3	K202/S202	Q25		G27 or G24
Side 1, eye side 4	K302/S302	Q32		G23 or G28
Side 1, eye side 3	K302/S302	Q33		G27 or G24
Side 5, eye side 4	K302/S302	Q34		G23 or G28
Side 5, eye side 3	K302/S302	Q35		G27 or G24
Side 1, eye side 4	K402/S402	Q42		G23 or G28
Side 1, eye side 3	K402/S402	Q43		G27 or G24
Side 5, eye side 4	K402/S402	Q44		G23 or G28
Side 5, eye side 3	K402/S402	Q45		G27 or G24
Side 1, eye side 4	K513	Q52		G23 or G28
Side 1, eye side 3	K513	Q53		G27 or G24
Side 5, eye side 4	K513	Q54		G23 or G28
Side 5, eye side 3	K513	Q55		G27 or G24
Side 1, eye side 4	K613	Q62		G23 or G28
Side 1, eye side 3	K613	Q63		G27 or G24
Side 5, eye side 4	K613	Q64		G23 or G28
Side 5, eye side 3	K613	Q65		G27 or G24
Side 1, eye side 4	K713	Q72		G23 or G28
Side 1, eye side 3	K713	Q73		G27 or G24
Side 5, eye side 4	K713	Q74		G23 or G28
Side 5, eye side 3	K713	Q75		G27 or G24
Side 1, eye side 4	K813	Q82		G23 or G28
Side 1, eye side 3	K813	Q83		G27 or G24
Side 5, eye side 4	K813	Q84		G23 or G28
Side 5, eye side 3	K813	Q85		G27 or G24

For a diagram with position of the torque bracket and position of the fixing eye, see page 4/88.

Servomotors

Geared servomotors for SINAMICS S120

1FK7 geared servomotors

Order No. supplements – Order codes

5th order code, other options

Paint finish: Jet black, matt RAL9005
 Paint finish: Cream white RAL 9001
 Paint finish: Reseda green RAL 6011
 Paint finish: Pebble gray RAL 7032
 Paint finish: Sky blue RAL 5015
 Paint finish: Light ivory RAL 1015
 Paint finish: Ash gray RAL 7000
 Paint finish: White aluminum RAL 9006
 Paint finish: Gentian blue RAL 5010
 Paint finish: Pure orange RAL 2004
 Food-grade gear oil

X01
 X02
 X03
 X04
 X05
 X06
 X07
 X08
 X12
 X19
 Q90

For option Q90, the Order No. for the geared servomotor must also be changed in the 16th position from 5 to 7: 1FK7...-5A.71-1..7-Z

4

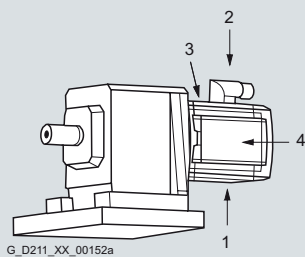

Connector mounting position

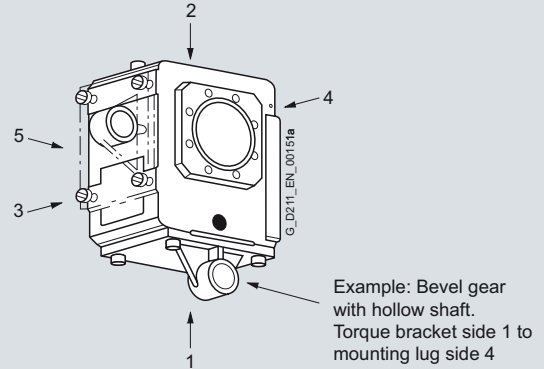

Gearbox sides shown with position of the torque bracket and position of the fixing eye

Order No. supplements – Order codes

Permissible combinations for option G.. with H.. and Q..

Order code	Description	Permissible G options for gearbox type			Permissible H-Q options for gearbox type		
		Helical gear	Offset-shaft	Bevel gear/worm	Helical gear	Offset-shaft	Bevel gear/worm
G11	Foot-mounted, solid shaft with fitted key	✓			H1. to H4. H6./H7.		
G13	Footed-mounted, hollow shaft with keyway (insertion gearbox side 4)						
G14	Footed-mounted, hollow shaft with shrink disk (insertion gearbox side 4)						
G15	Foot-mounted, solid shaft with fitted key (gearbox side 3)						
G17	Footed-mounted, hollow shaft with keyway (insertion gearbox side 3)						
G18	Footed-mounted, hollow shaft with shrink disk (gearbox side 3)						
G21	Tapped hole group, solid shaft with keyway (gearbox side 4 for bevel and worm)	✓		✓ 1)	H1./H6./H8.		H1. to H6.
G23	Tapped hole group, hollow shaft with keyway (insertion gearbox side 5 for offset-shaft gearbox, insertion side 4 for bevel and worm)		✓	✓ 1)		H1. to H6.	H1. to H6. Q..
G24	Tapped hole group, hollow shaft with shrink disk (shrink disk on gearbox side 6 and insertion side 5 for offset-shaft gearbox; shrink disk on gearbox side 4 and insertion side 3 for bevel and worm)		✓	✓ 1)			
G25	Tapped hole group, solid shaft with fitted key (gearbox side 3)			✓ 1)			H1. to H6.
G27	Tapped hole group, hollow shaft with fitted key (insertion gearbox side 3)			✓ 1)			H1. to H6. Q..
G28	Tapped hole group, hollow shaft with clamping element (shrink disk on gearbox side 3 and insertion side 4 for bevel and worm)			✓ 1)			
G31	Flange (round), solid shaft with fitted key (gearbox side 5 for offset-shaft gearbox; side 4 for bevel and worm)	✓	✓	✓ 1)	H1./H5./H6.	H1. to H6.	H1. to H6.
G33	Flange (round), hollow shaft with keyway (insertion gearbox side 4)		✓	✓ 1)			
G34	Flange (round), hollow shaft with shrink disk, shrink disk on gearbox side 6 and insertion side 5 for offset-shaft gearbox; shrink disk on gearbox side 4 and insertion side 3 for bevel and worm)		✓	✓ 1)			
G35	Flange (round), solid shaft with fitted key (gearbox side 3)			✓ 1)			
G37	Flange (round), hollow shaft with keyway (insertion gearbox side 3)			✓ 1)			
G38	Flange (round), hollow shaft with clamping element (shrink disk on gearbox side 3 and insertion side 4 for bevel and worm)			✓			

1) Not for worm gear of gearbox size S002 (gearbox type E0.).

Servomotors

Geared servomotors for SINAMICS S120

1FK7 geared servomotors

Order No. supplements – Order codes

Permissible combinations for option G.. with H..

Order code	Description	Permissible G options for gearbox type		Permissible H options for gearbox type	
		Helical gear	Bevel gear/worm	Helical gear	Bevel gear/worm
G51	Foot-mounted and flange (round), solid shaft with fitted key (gearbox side 4 for bevel and worm)	✓ 1)	✓ 2)	H1./H2.	H1. to H6.
G53	Foot-mounted and flange (round), hollow shaft with keyway (insertion gearbox side 4)		✓ 2)		
G54	Foot-mounted and flange (round), hollow shaft with clamping element (shrink disk on gearbox side 4 and insertion side 4 for bevel and worm)		✓ 2)		
G55	Foot-mounted and flange (round), solid shaft with fitted key (gearbox side 3)		✓ 2)		
G57	Foot-mounted and flange (round), hollow shaft with keyway (insertion gearbox side 3)		✓ 2)		
G58	Foot-mounted and flange (round), hollow shaft with clamping element (shrink disk on gearbox side 3 and insertion side 4 for bevel and worm)		✓ 2)		
G61	Foot-mounted and tapped hole group, solid shaft with fitted key (gearbox side 4 for bevel and worm)	✓	✓	H1./H2.	H1. to H6.
G63	Foot-mounted and tapped hole group, hollow shaft with keyway (insertion gearbox side 4)		✓		
G64	Foot-mounted and tapped hole group, hollow shaft with clamping element (shrink disk on gearbox side 4 and insertion side 4 for bevel and worm)		✓		
G65	Foot-mounted and tapped hole group, solid shaft with fitted key (gearbox side 3)		✓		
G67	Foot-mounted and tapped hole group, hollow shaft with keyway (insertion gearbox side 3)		✓		
G68	Foot-mounted and tapped hole group, hollow shaft with clamping element (shrink disk on gearbox side 3 and insertion side 4 for bevel and worm)		✓		

1) The flange diameter for helical gearboxes with foot mounting and flange is one diameter grade smaller in each case than the diameter for helical gearboxes with flange only (without foot mounting).

2) Only for 1FK706 to 1FK710 with gearbox sizes K513 to K813 (gearbox types B5. to B8.).

Selection guides

Helical geared motors – Types of construction

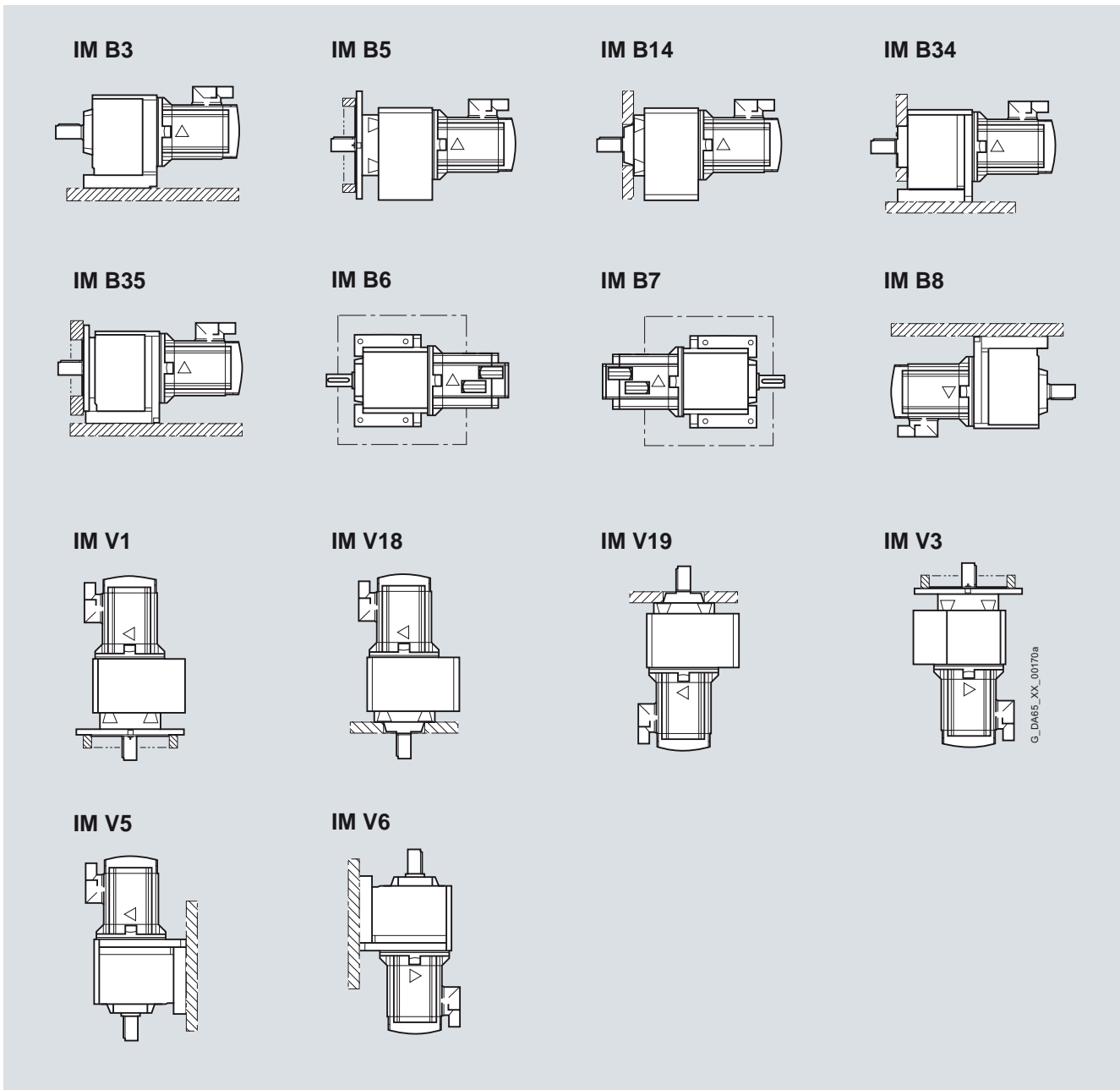

Servomotors

Geared servomotors for SINAMICS S120

1FK7 geared servomotors

Selection guides

Offset-shaft geared motors – Mounting positions EL 1 to EL 6

4

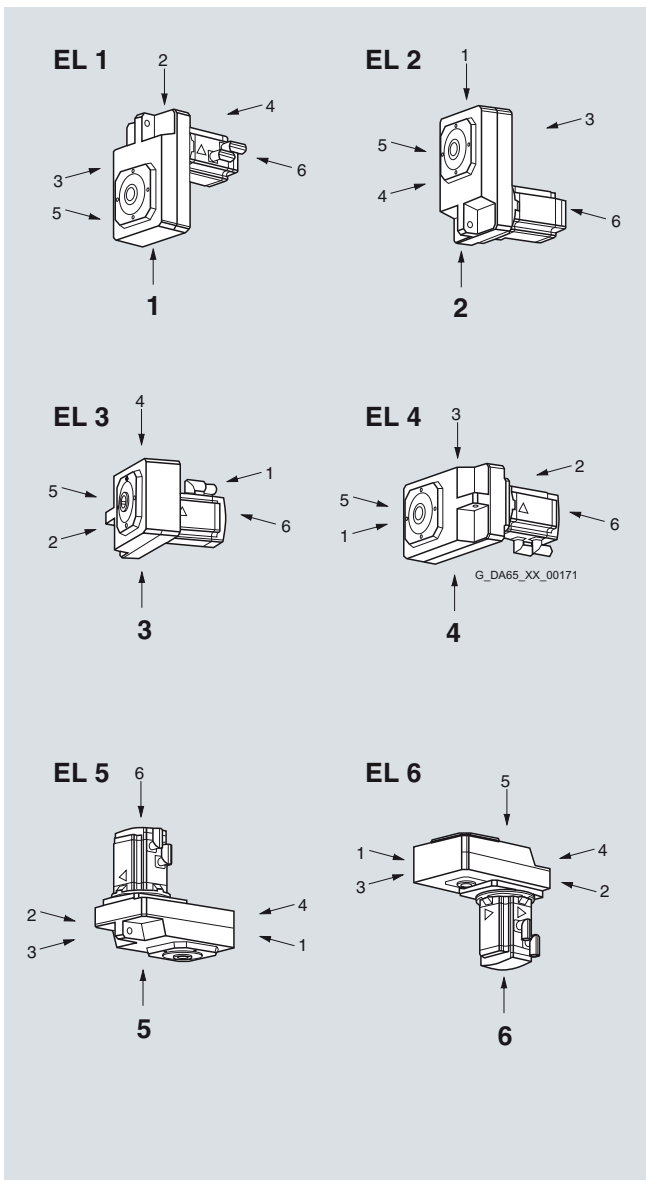

Selection guides

Bevel geared motors – Mounting positions EL 1 to EL 6

Gearbox sizes K102 to K402

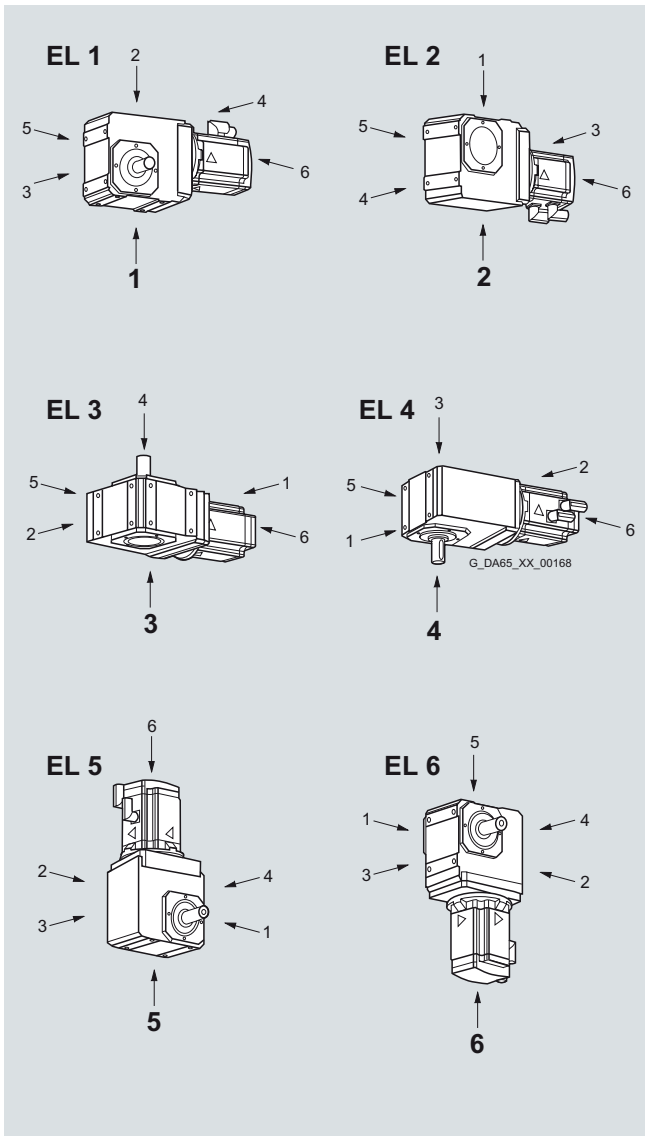

Gearbox sizes K513 to K813

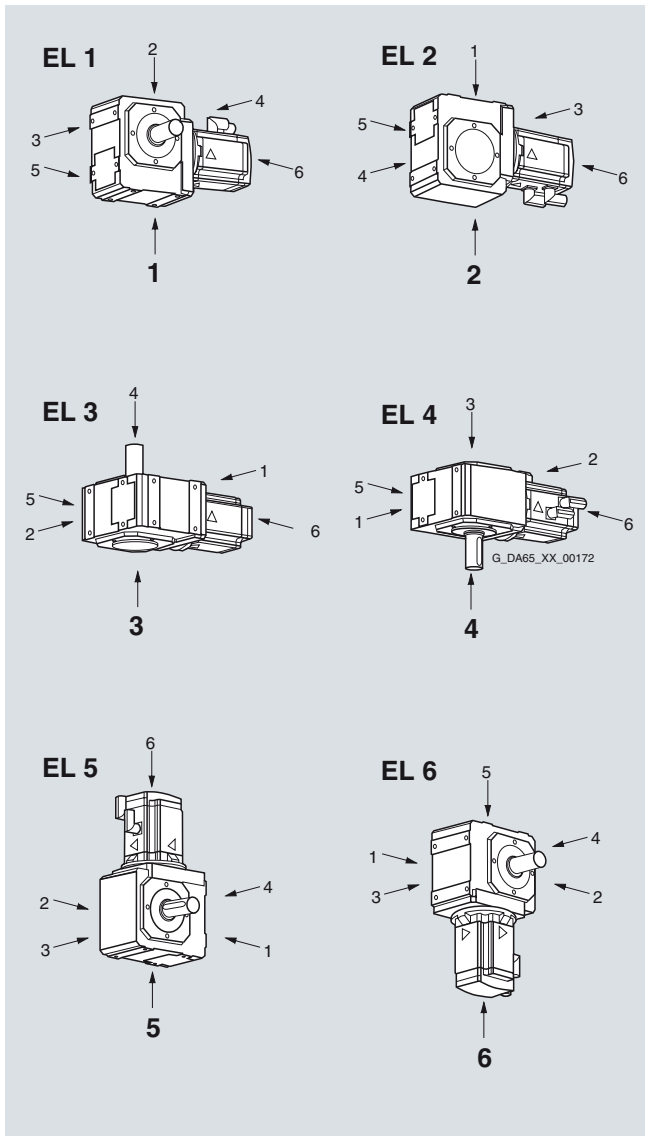

Servomotors

Geared servomotors for SINAMICS S120

1FK7 geared servomotors

Selection guides

Worm geared motors – Mounting positions EL 1 to EL 6

Gearbox size S002

Gearbox sizes S102 to S402

4

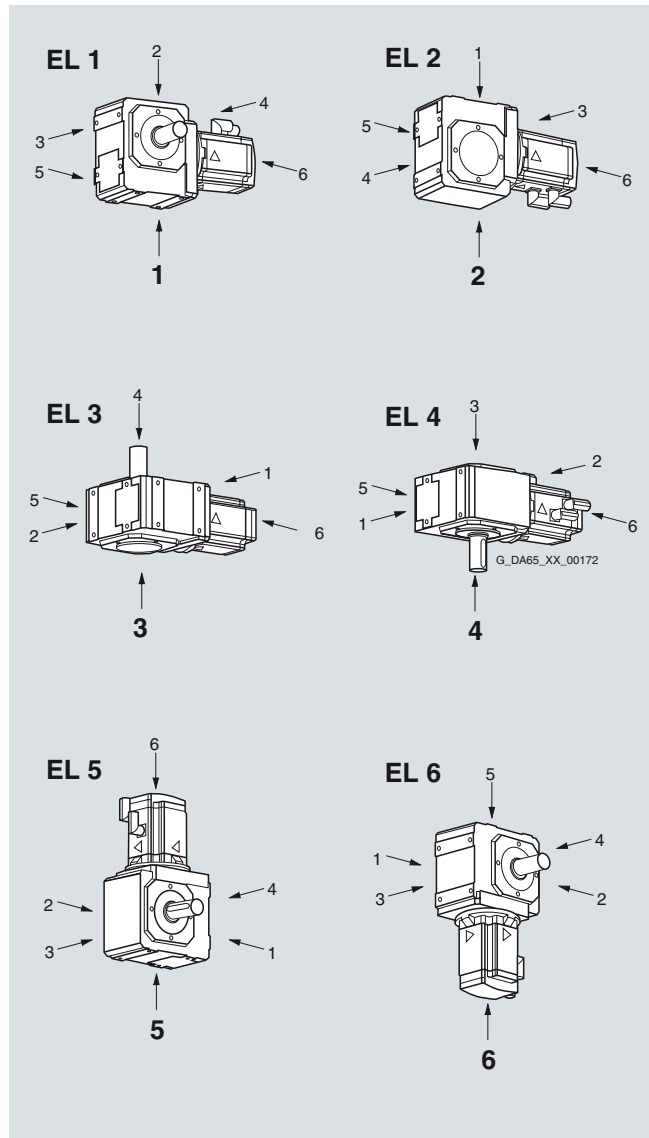
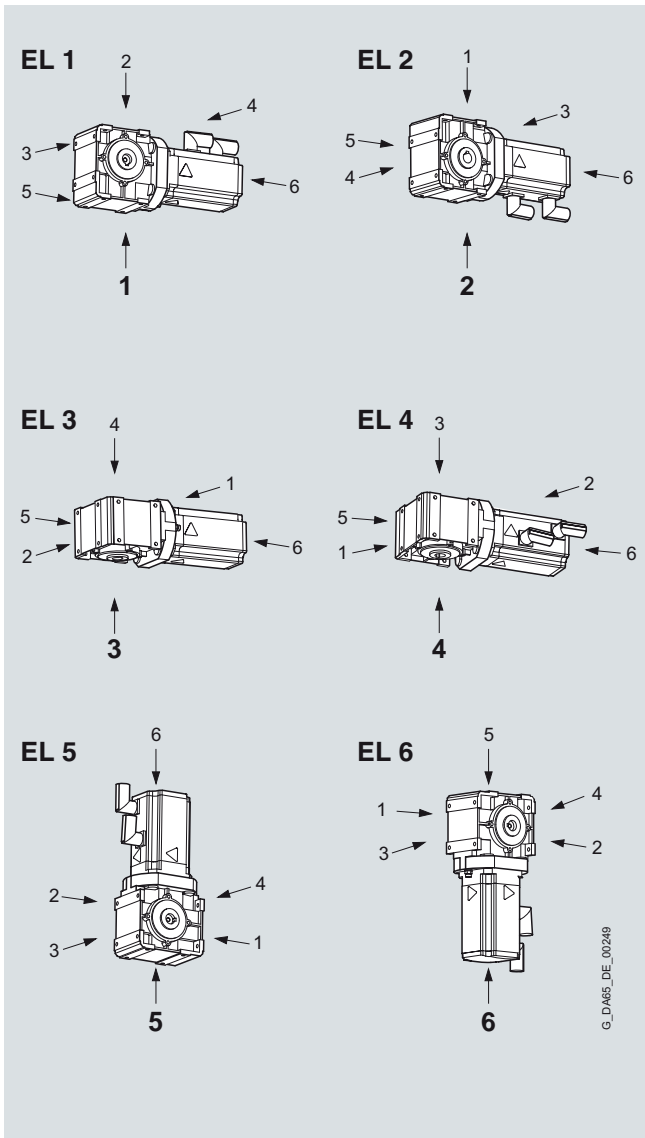

Servomotors

Dimensional drawings

1FT7 Compact motors with/without DRIVE-CLiQ Natural cooling

4

Dimensional drawings

For motor		Dimensions in mm (inches)											Flange 1 (1FT6-compatible)			
Shaft height	Type	DIN IEC	a ₁ P	b ₁ N	c ₁ LA	e ₁ M	f AB	f ₁ T	g ₁ -	o ₁ -	s ₂ S	i ₂ -	without brake		with brake	
													k LB	o -	k LB	o -
1FT7 Compact, type of construction IM B5, natural cooling, with connector, with/without brake																
36	1FT7034		90 (3.54)	60 (2.36)	8 (0.31)	75 (2.95)	72 (2.83)	3 (0.12)	80 (3.15)	48 (1.89)	6.5 (0.26)	30 (1.18)	195 (7.68)	133 (5.24)	222 (8.74)	160 (6.30)
	1FT7036												243 (9.57)	181 (7.13)	270 (10.63)	208 (8.19)
48	1FT7042		120 (4.72)	80 (3.15)	10 (0.39)	100 (3.94)	96 (3.78)	3 (0.12)	93 (3.66)	53 (2.09)	6.5 (0.26)	40 (1.57)	169 (6.65)	102 (4.02)	201 (7.91)	134 (5.28)
	1FT7044												219 (8.62)	152 (5.98)	251 (9.88)	184 (7.24)
	1FT7046												259 (10.20)	192 (7.56)	291 (11.46)	224 (8.82)
63	1FT7062		155 (6.10)	110 (4.33)	10 (0.39)	130 (5.12)	126 (4.96)	3.5 (0.14)	108 (4.25)	53 (2.09)	9 (0.35)	50 (1.97)	173 (6.81)	106 (4.17)	208 (8.19)	141 (5.55)
	1FT7064												205 (8.07)	137 (5.39)	240 (9.45)	173 (6.81)
	1FT7066												236 (9.29)	169 (6.65)	272 (10.71)	204 (8.03)
	1FT7068												284 (11.18)	216 (8.50)	319 (12.56)	252 (9.92)

Shaft height	Type	DIN IEC	Flange 0			Shaft extension DE				d D	d ₆ -	l E	t GA	u F
			b ₂ -	f ₂ -	i ₂ -	without brake		with brake						
			k LB	o -	k LB	o -	k LB	o -						
36	1FT7034		36 (1.42)	5.5 (0.22)	36.5 (1.44)	189 (7.44)	127 (5.00)	216 (8.50)	154 (6.06)	14 (0.55)	M5	30 (1.18)	16 (0.63)	5 (0.20)
	1FT7036					237 (9.33)	175 (6.89)	264 (10.39)	202 (7.95)					
48	1FT7042		46 (1.81)	5.5 (0.22)	46 (1.81)	163 (6.42)	96 (3.78)	195 (7.68)	128 (5.04)	19 (0.75)	M6	40 (1.57)	21.5 (0.85)	6 (0.24)
	1FT7044					213 (8.39)	146 (5.75)	245 (9.65)	178 (7.01)					
	1FT7046					253 (9.96)	186 (7.32)	285 (11.22)	218 (8.58)					
63	1FT7062		51 (2.01)	6 (0.24)	56.5 (2.22)	167 (6.57)	99 (3.90)	202 (7.95)	135 (5.31)	24 (0.94)	M8	50 (1.97)	27 (1.06)	8 (0.31)
	1FT7064					198 (7.80)	131 (5.16)	233 (9.17)	166 (6.54)					
	1FT7066					230 (9.06)	162 (6.38)	265 (10.43)	198 (7.80)					
	1FT7068					277 (10.91)	210 (8.27)	312 (12.28)	245 (9.65)					

Flange 1
(1FT6-compatible)
1FT703
1FT704
1FT706

Shaft design
with fitted key

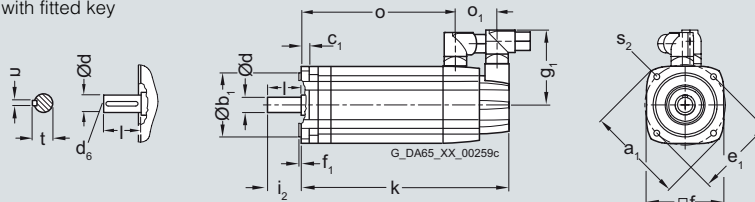

Flange 0
1FT703
1FT704
1FT706

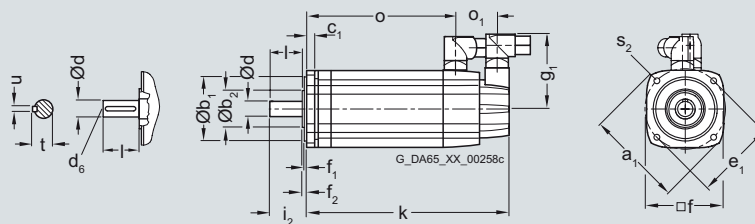

Servomotors

Dimensional drawings

1FT7 Compact motors with/without DRIVE-CLiQ Natural cooling

Dimensional drawings

For motor		Dimensions in mm (inches)											Flange 1 (1FT6-compatible)					
Shaft height	Type	DIN IEC	a ₁ P	b ₁ N	c ₁ LA	e ₁ M	f AB	f ₁ T	Connector				Flange 1 (1FT6-compatible)					
									Size 1		Size 1.5		without brake		with brake			
									g ₁ –	g ₁ –	o ₁ –	s ₂ S	i ₂ –	k LB	o –	k LB	o –	
1FT7 Compact, type of construction IM B5, natural cooling, with connector, with/without brake																		
80	1FT7082		195 (7.68)	130 (5.12)	11.5 (0.45)	165 (6.50)	155 (6.10)	3.5 (0.14)	119 (4.69)	141 (5.55)	51 (2.01)	11 (0.43)	58 (2.28)	196 (7.72)	130 (5.12)	248 (9.76)	183 (7.20)	
	1FT7084													247 (9.72)	182 (7.17)	299 (11.77)	234 (9.21)	
	1FT7086													299 (11.77)	234 (9.21)	351 (13.82)	286 (11.26)	
100	1FT7102		245 (9.65)	180 (7.09)	13 (0.51)	215 (8.46)	196 (7.72)	4 (0.16)	–	161 (6.34)	56 (2.20)	14 (0.55)	80 (3.15)	221 (8.70)	151 (5.94)	273 (10.75)	203 (7.99)	
	1FT7105													307 (12.09)	238 (9.37)	360 (14.17)	290 (11.42)	
	1FT7108													377 (14.84)	307 (12.09)	429 (16.89)	359 (14.13)	

Shaft height	Type	DIN IEC	Flange 0				Shaft extension DE				Shaft extension DE			
			b ₂ –	f ₂ –	i ₂ –	k LB	o –	k LB	o –	d D	d ₆ –	l E	t GA	u F
80	1FT7082		66 (2.60)	6 (0.24)	64.5 (2.54)	189 (7.44)	124 (4.88)	241 (9.49)	176 (6.93)	32 (1.26)	M12	58 (2.28)	35 (1.38)	10 (0.39)
	1FT7084					241 (9.49)	175 (6.89)	293 (11.54)	228 (8.98)					
	1FT7086					292 (11.50)	227 (8.94)	345 (13.58)	279 (10.98)					
100	1FT7102		81 (3.19)	6.5 (0.26)	87 (3.43)	214 (8.43)	144 (5.67)	266 (10.47)	196 (7.72)	38 (1.50)	M12	80 (3.15)	41 (1.61)	10 (0.39)
	1FT7105					301 (11.85)	231 (9.09)	353 (13.90)	283 (11.14)					
	1FT7108					370 (14.57)	300 (11.81)	422 (16.61)	352 (13.86)					

Flange 1
(1FT6-compatible)
1FT708
1FT710

Shaft design
with fitted key

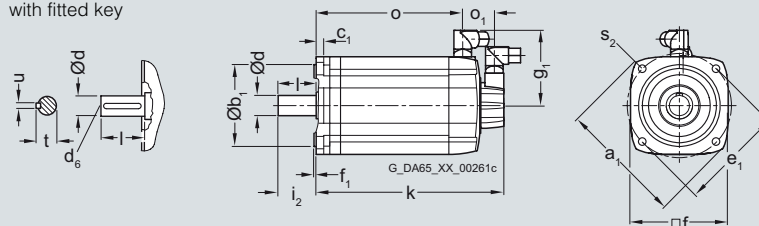

Flange 0
1FT708
1FT710

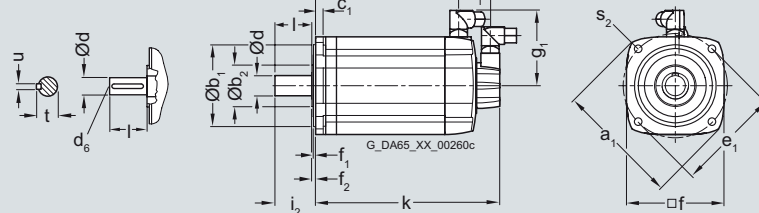

1FT7 Compact motors with/without DRIVE-CLiQ Forced ventilation

Dimensional drawings

For motor Dimensions in mm (inches)

Shaft height	Type	DIN IEC	a ₁ P	b	b ₁ N	c ₁ LA	e ₁ M	f AB	f ₁ T	Connector			h H	h ₁	Fan		s ₂ S
										Size 1.5 g ₁	Size 3 g ₁	g ₃			h ₂	o ₁	
1FT7 Compact, type of construction IM B5, forced ventilation, with connector, with/without brake																	
80	1FT7084		194 (7.64)	186 (7.32)	130 (5.12)	11.5 (0.45)	165 (6.50)	155 (6.10)	3.5 (0.14)	139 (5.47)	-	137.5 (5.41)	27 (1.06)	177 (6.97)	186.5 (7.34)	50 (1.97)	11 (0.43)
	1FT7086																
100	1FT7105		245 (9.65)	224 (8.82)	180 (7.09)	13 (0.51)	215 (8.46)	196 (7.72)	4 (0.16)	159 (6.26)	187 (7.36)	151 (5.94)	27 (1.06)	220 (8.66)	222 (8.74)	55 (2.17)	14 (0.55)
	1FT7108																

Shaft height	Type	DIN IEC	Flange 1 (1FT6-compatible)				Flange 0				Shaft extension DE								
			i ₂	k LB	o	o	k LB	o	b ₂	f ₂	i ₂	k LB	o	k LB	o	d D	d ₆	l E	t GA
80	1FT7084		58 (2.28)	342 (13.46)	182 (7.17)	394 (15.51)	234 (9.21)	66 (2.60)	6 (0.24)	64.5 (2.54)	335.5 (13.21)	175 (6.89)	387.5 (15.26)	228 (8.98)	32 (1.26)	M12	58 (2.28)	35 (1.38)	10 (0.39)
	1FT7086			393.5 (15.49)	234 (9.21)	446 (17.56)	286 (11.26)				387 (15.24)	227 (8.94)	439.5 (17.30)	279 (10.98)					
100	1FT7105		80 (3.15)	403.5 (15.89)	238 (9.37)	455.5 (17.93)	290 (11.42)	81 (3.19)	6.5 (0.26)	87 (3.43)	396.5 (15.61)	231 (9.09)	448.5 (17.66)	283 (11.14)	38 (1.50)	M12	80 (3.15)	41 (1.61)	10 (0.39)
	1FT7108			473 (18.62)	307 (12.09)	525 (20.57)	359 (14.13)				466 (18.35)	300 (11.81)	518 (20.39)	352 (13.86)					

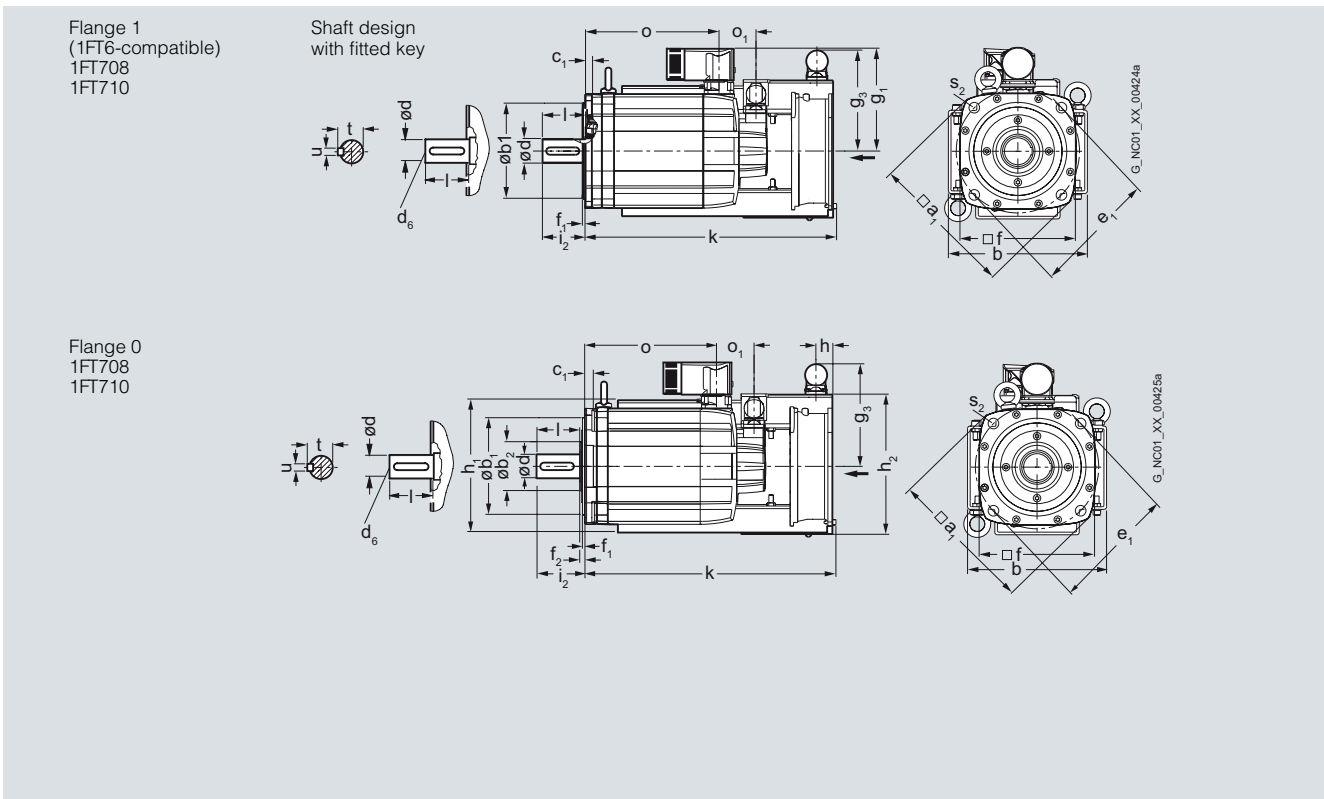

Servomotors

Dimensional drawings

1FT7 Compact motors with/without DRIVE-CLiQ Water cooling

Dimensional drawings

For motor Dimensions in mm (inches)

Shaft height	Type	DIN IEC	a ₁ P	b	b ₁ N	c ₁ LA	e ₁ M	f AB	f ₁ T	Connector			Connector			S ₂ S
										Size 1	Size 1.5	Size 3	Size 1	Size 1.5	Size 3	
										g ₁	g ₁	g ₁	o ₁	o ₁	o ₁	
1FT7 Compact, type of construction IM B5, water cooling, with connector, with/without brake																
63	1FT7062 1FT7064 1FT7066 1FT7068		155 (6.10)	135 (5.31)	110 (4.33)	10 (0.39)	130 (5.12)	126 (4.96)	3.5 (0.14)	108 (4.25)	-	-	52 (2.05)	-	-	9 (0.35)
80	1FT7082 1FT7084 1FT7086		195 (7.68)	165 (6.50)	130 (5.12)	11.5 (0.45)	165 (6.50)	155 (6.10)	3.5 (0.14)	-	140 (5.51)	-	-	50 (1.97)	-	11 (0.43)
100	1FT7102 1FT7105 1FT7108		245 (9.65)	206 (8.11)	180 (7.09)	13 (0.51)	215 (8.46)	196 (7.72)	4 (0.16)	-	160 (6.30)	-	-	55 (2.17)	-	14 (0.55)
												187 (7.36)			72 (2.83)	

Shaft height	Type	DIN IEC	Flange 1 (1FT6-compatible) without/with brake				Flange 0				without/with brake			Shaft extension DE					
			i ₂	k LB	o	o	o	b ₂	f ₂	i ₂	k LB	o	o	o	d D	d ₆	l E	t GA	u F
63	1FT7062 1FT7064 1FT7066 1FT7068		50 (1.97)	208 (8.19)	141 (5.55)	-	-	51 (2.01)	6 (0.24)	56.5 (2.22)	202 (7.95)	135 (5.31)	-	-	24 (0.94)	M8	50 (1.97)	27 (1.06)	8 (0.31)
80	1FT7082 1FT7084 1FT7086		58 (2.28)	248 (9.76)	-	183 (7.20)	-	66 (2.60)	6 (0.24)	64.5 (2.54)	241 (9.49)	-	176 (6.93)	-	32 (1.26)	M12	58 (2.28)	35 (1.38)	10 (0.39)
100	1FT7102 1FT7105 1FT7108		80 (3.15)	273 (10.75)	-	203 (7.99)	-	81 (3.19)	6.5 (0.26)	87 (3.43)	266 (10.47)	-	196 (7.72)	-	38 (1.50)	M12	80 (3.15)	41 (1.61)	10 (0.39)

Flange 1
(1FT6-compatible)
1FT706
1FT708
1FT710

Shaft design
with fitted key

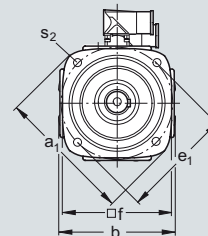
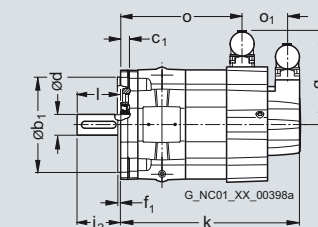
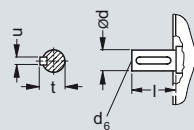

Flange 0
1FT706
1FT708
1FT710

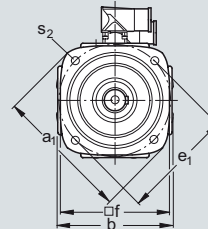
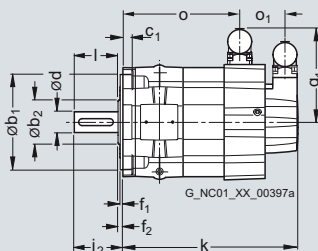
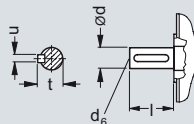

1FT7 High Dynamic motors with/without DRIVE-CLiQ – Forced ventilation

Dimensional drawings

For motor Dimensions in mm (inches)

Shaft height	Type	DIN IEC	a ₁ P	b A	b ₁ N	c ₁ LA	e ₁ M	f AB	f ₁ T	Connector Size 1.5		Fan				
										g ₁ –	g ₃ –	h H	h ₁ –	h ₂ –	o ₁ –	s ₂ S
1FT7 High Dynamic, forced ventilation, with connector, with/without brake																
63	1FT7065		155 (6.10)	158 (6.22)	110 (4.33)	10 (0.39)	130 (5.12)	126 (4.96)	3.5 (0.14)	125 (4.92)	101.5 (4.00)	26 (1.02)	143 (5.63)	135 (5.31)	57 (2.24)	9 (0.35)
	1FT7067															

Shaft height	Type	DIN IEC	Flange 1 (1FT6-compatible)				Flange 0				without brake		with brake		Shaft extension DE				
			i ₂ LB	k LB	o –	o LB	b ₂ –	f ₂ –	i ₂ –	k LB	o –	k LB	o –	d D	d ₆ –	l E	t GA	u F	
63	1FT7065		50 (1.97)	380 (14.96)	220 (8.66)	380 (14.96)	220 (8.66)	51 (2.01)	6 (0.24)	56.5 (2.22)	373.5 (14.70)	214 (8.43)	373.5 (14.70)	214 (8.43)	24 (0.94)	M8	50 (1.97)	27 (1.06)	8 (0.31)
	1FT7067			420 (16.54)	260 (10.24)	420 (16.54)	260 (10.24)				413.5 (16.28)	254 (10.00)	413.5 (16.28)	254 (10.00)					

Flange 1 (1FT6-compatible)
1FT706

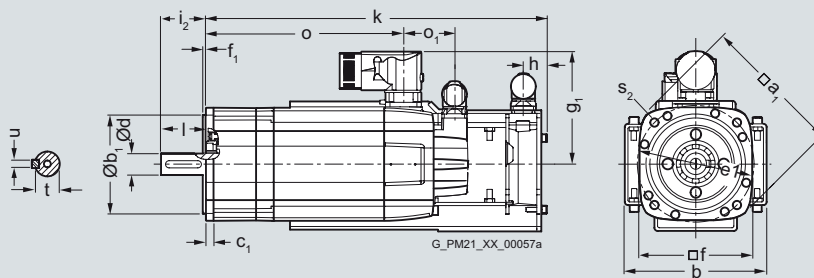

Flange 0 (1FT6-compatible)
1FT706

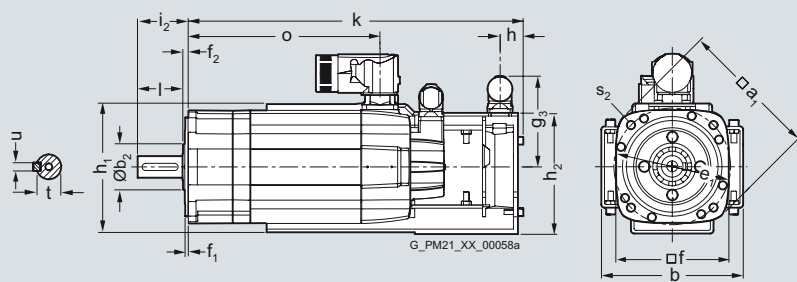

Servomotors

Dimensional drawings

1FT7 High Dynamic motors with/without DRIVE-CLiQ – Forced ventilation

Dimensional drawings

For motor Dimensions in mm (inches)

Shaft height	Type	DIN IEC	a ₁ P	b A	b ₁ N	c ₁ LA	e ₁ M	f AB	f ₁ T	Connector Size		Fan					
										1 g ₁	3 g ₁	g ₃	h H	h ₁	h ₂	o ₁	s ₂ S
1FT7 High Dynamic, forced ventilation, with connector, with/without brake																	
80	1FT7085		194 (7.64)	186 (7.32)	130 (5.12)	11.5 (0.45)	165 (6.50)	155 (6.10)	3.5 (0.14)	139 (5.47)	166.5 (6.56)	137.5 (5.41)	27 (1.06)	177 (6.97)	186.5 (7.34)	50 (1.97)	11 (0.43)
	1FT7087										166.5 (6.56)						

4

Shaft height	Type	DIN IEC	Flange 1 (1FT6-compatible)				Flange 0				Shaft extension DE								
			i ₂	k LB	o	o	k LB	o	b ₂	f ₂	i ₂	k LB	o	k LB	o	d D	d ₆	l E	t GA
80	1FT7085		58 (2.28)	414 (16.30)	254 (10.00)	414 (16.30)	254 (10.00)	66 (2.60)	6 (0.24)	64.5 (2.54)	407.5 (16.04)	247 (9.72)	407.5 (16.04)	247 (9.72)	32 (1.26)	M12	58 (2.28)	35 (1.38)	10 (0.39)
	1FT7087			474 (18.66)	314 (12.36)	474 (18.66)	314 (12.36)				467.5 (18.41)	307 (12.09)	467.5 (18.41)	307 (12.09)					

Flange 1 (1FT6-compatible)
1FT708

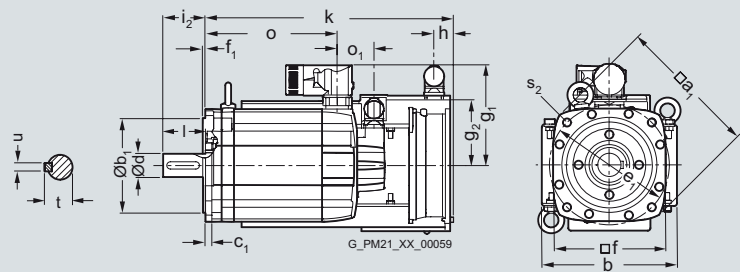

Flange 0
1FT708

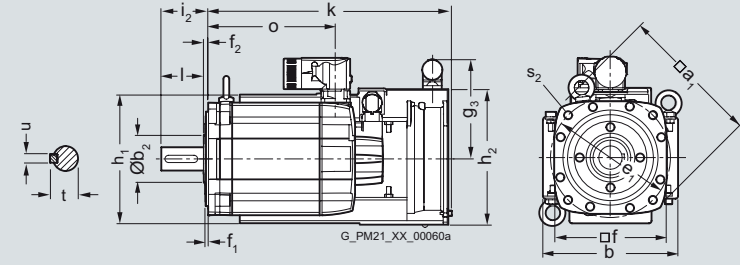

1FT7 High Dynamic motors with/without DRIVE-CLiQ – Water cooling

Dimensional drawings

For motor		Dimensions in mm (inches)											
Shaft height	Type	DIN IEC	a ₁ P	b A	b ₁ N	c ₁ LA	e ₁ M	f AB	f ₁ T	Connector Size		o ₁	s ₂ S
										1.5	3		
1FT7 High Dynamic, water cooling, with connector, with/without brake													
63	1FT7065 1FT7067		155 (6.10)	135 (5.31)	110 (4.33)	10 (0.39)	130 (5.12)	126 (4.96)	3.5 (0.14)	132.5 (5.22)	–	57 (2.24)	9 (0.35)
80	1FT7085 1FT7087		194 (7.64)	165 (6.50)	130 (5.12)	11.5 (0.45)	165 (6.50)	155 (6.10)	3.5 (0.14)	140.5 (5.53)	168.5 (6.63)	50 (1.97)	11 (0.43)

Shaft height	Type	DIN IEC	Flange 1 (1FT6-compatible)				Flange 0				Shaft extension DE								
			without brake		with brake		without brake		with brake		d	d ₆	l	t	u				
			i ₂	k	o	k	o	b ₂	f ₂	i ₂	k	o	k	o	D	–	E	GA	F
63	1FT7065 1FT7067		50 (1.97)	292 (11.50)	220 (8.66)	292 (11.50)	220 (8.66)	51 (2.01)	6 (0.24)	56.5 (2.22)	285.5 (11.24)	214 (8.43)	285.5 (11.24)	214 (8.43)	24 (0.94)	M8	50 (1.97)	27 (1.06)	8 (0.31)
80	1FT7085 1FT7087		58 (2.28)	319 (12.56)	254 (10.00)	319 (12.56)	254 (10.00)	66 (2.60)	6 (0.24)	64.5 (2.54)	312.5 (12.30)	247 (9.72)	312.5 (12.30)	247 (9.72)	32 (1.26)	M12	58 (2.28)	35 (1.38)	10 (0.39)

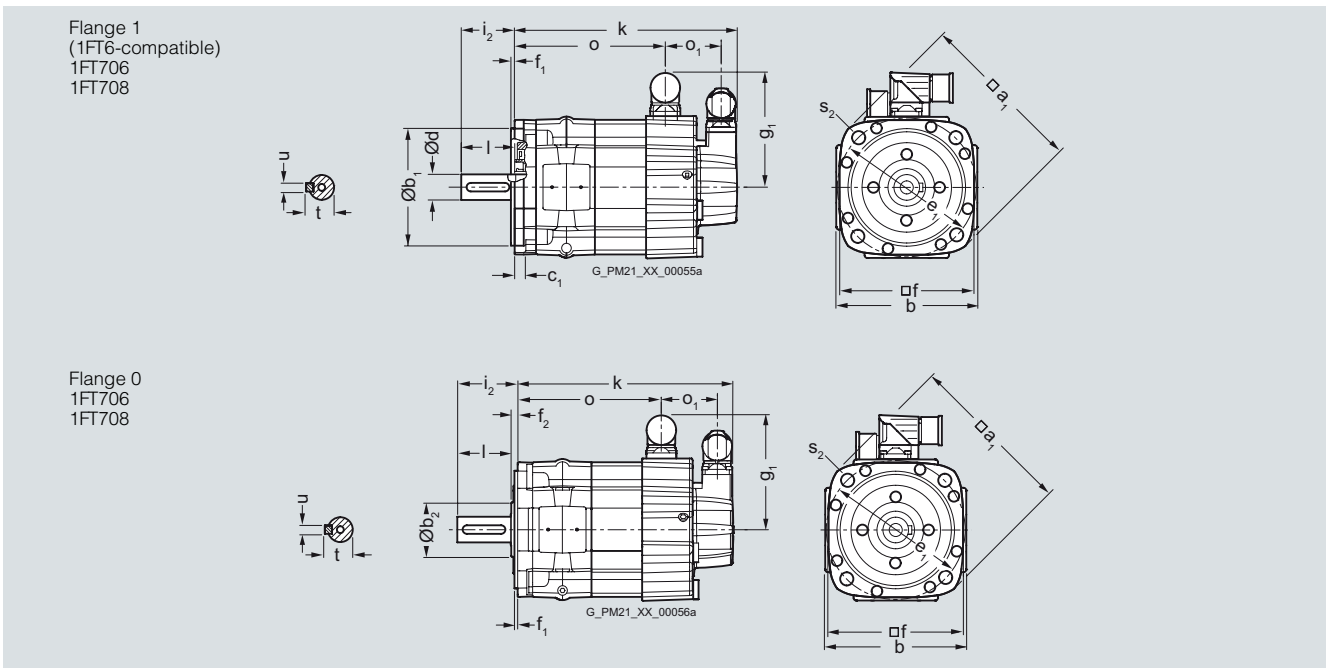

Servomotors

Dimensional drawings

1FK7 Compact motors with/without DRIVE-CLiQ Natural cooling

Dimensional drawings

For motor Dimensions in mm (inches)

Shaft height	Type	DIN IEC	a ₁ P	b ₁ N	c ₁ LA	e ₁ M	f AB	f ₁ T	g ₂ -	h H	i ₂ -	s ₂ S	Encoder system:					
													Resolver Absolute encoder AM16S/R / AM15DQ					
													without brake			with brake		
													k LB	o ₁ -	o ₂ -	k LB	o ₁ -	o ₂ -
1FK7 Compact, type of construction IM B5, natural cooling, with connector, with/without brake																		
20	1FK7011-5		-	30 (1.18)	7 (0.28)	46 (1.81)	40 (1.57)	2.5 (0.10)	65.5 (2.58)	20 (0.79)	18 (0.71)	4.5 (0.18)	140 (5.51)	89 (3.50)	118 (4.65)	140 (5.51)	89 (3.50)	118 (4.65)
	1FK7015-5												165 (6.50)	114 (4.49)	143 (5.63)	165 (6.50)	114 (4.49)	143 (5.63)
28	1FK7022-5		-	40 (1.57)	10 (0.39)	63 (2.48)	55 (2.17)	2.5 (0.10)	75 (2.95)	27.5 (1.08)	20 (0.79)	5.4 (0.21)	153 (6.02)	95 (3.74)	128 (5.04)	175 (6.89)	95 (3.74)	150 (5.91)
36	1FK7032-5	92 (3.62)	60 (2.36)	8 (0.31)	75 (2.95)	72 (2.83)	3 (0.12)	81 (3.19)	36 (1.42)	30 (1.18)	6.5 (0.26)	150 (5.91)	90 (3.54)	125 (4.92)	175 (6.89)	90 (3.54)	149 (5.87)	
	1FK7034-5											175 (6.89)	115 (4.53)	150 (5.91)	200 (7.87)	115 (4.53)	174 (6.85)	
48	1FK7040-5	120 (4.72)	80 (3.15)	10 (0.39)	100 (3.94)	96 (3.78)	3 (0.12)	90 (3.54)	48 (1.89)	40 (1.57)	7 (0.28)	134 (5.28)	73 (2.87)	106 (4.17)	163 (6.42)	73 (2.87)	135 (5.31)	
	1FK7042-5											162 (6.38)	101 (3.98)	134 (5.28)	191 (7.52)	101 (3.98)	163 (6.42)	
63	1FK7060-5	155 (6.10)	110 (4.33)	10 (0.39)	130 (5.12)	126 (4.96)	3.5 (0.14)	105 (4.13)	63 (2.48)	50 (1.97)	9 (0.35)	157 (6.18)	94 (3.70)	126 (4.96)	200 (7.87)	94 (3.70)	169 (6.65)	
	1FK7063-5											202 (7.95)	139 (5.47)	171 (6.73)	245 (9.65)	139 (5.47)	214 (8.43)	

Shaft height	Type	Encoder system:						Shaft extension DE															
		Incremental encoder IC2048S/R / IC22DQ Absolute encoder AM2048S/R / AM22DQ AM512S/R / AM20DQ AM32S/R / AM16DQ																					
												without brake			with brake								
												k LB	o ₁ -	o ₂ -	k LB	o ₁ -	o ₂ -	d D	d ₆ -	l E	t GA	u F	
20	1FK7011-5	155 (6.10)	89 (3.50)	118 (4.65)	155 (6.10)	89 (3.50)	118 (4.65)	8 (0.31)	-	18 (0.71)	8.8 (0.35)	2 (0.08)											
	1FK7015-5	180 (7.09)	114 (4.49)	143 (5.63)	180 (7.09)	114 (4.49)	143 (5.63)																
28	1FK7022-5	178 (7.01)	95 (3.74)	128 (5.04)	200 (7.87)	95 (3.74)	150 (5.91)	9 (0.35)	M3	20 (0.79)	10.2 (0.40)	3 (0.12)											
36	1FK7032-5	175 (6.89)	90 (3.54)	125 (4.92)	200 (7.87)	90 (3.54)	149 (5.87)	14 (0.55)	M5	30 (1.18)	16 (0.63)	5 (0.20)											
	1FK7034-5	200 (7.87)	115 (4.53)	150 (5.91)	225 (8.86)	115 (4.53)	174 (6.85)																
48	1FK7040-5	155 (6.10)	73 (2.87)	106 (4.17)	184 (7.24)	73 (2.87)	135 (5.31)	19 (0.75)	M6	40 (1.57)	21.5 (0.85)	6 (0.24)											
	1FK7042-5	182 (7.17)	101 (3.98)	134 (5.28)	211 (8.31)	101 (3.98)	163 (6.42)																
63	1FK7060-5	180 (7.09)	94 (3.70)	126 (4.96)	223 (8.78)	94 (3.70)	169 (6.65)	24 (0.94)	M8	50 (1.97)	27 (1.06)	8 (0.31)											
	1FK7063-5	225 (8.86)	139 (5.47)	171 (6.73)	268 (10.55)	139 (5.47)	214 (8.43)																

1FK701.-5
1FK702.-5
1FK703.-5
1FK704.-5
1FK706.-5

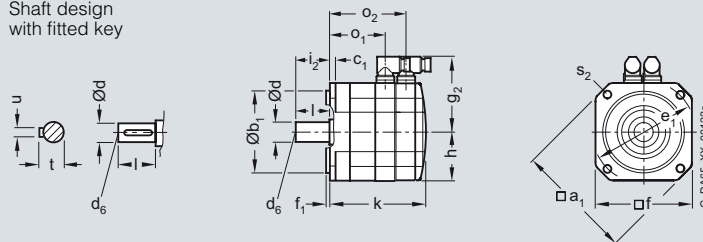
Shaft design
with fitted key

1FK7 Compact motors with/without DRIVE-CLiQ Natural cooling

Dimensional drawings

For motor		Dimensions in mm (inches)											Encoder system: Resolver					
Shaft height	Type	DIN IEC	a ₁ P	b ₁ N	c ₁ LA	e ₁ M	f AB	f ₁ T	g ₂ -	h H	i ₂ -	s ₂ S	without brake			with brake		
													k LB	o ₁ -	o ₂ -	k LB	o ₁ -	o ₂ -
1FK7 Compact, type of construction IM B5, natural cooling, with connector, with/without brake																		
80	1FK7080-5		186 (7.32)	130 (5.12)	13 (0.51)	165 (6.50)	155 (6.10)	3.5 (0.14)	119.5 (4.70)	77.5 (3.05)	58 (2.28)	11 (0.43)	156 (6.14)	91 (3.58)	124 (4.88)	184 (7.24)	91 (3.58)	151 (5.94)
	1FK7083-5												194 (7.64)	129 (5.08)	162 (6.38)	245 (9.65)	129 (5.08)	207 (8.15)
100	1FK7100-5		240 (9.45)	180 (7.09)	13 (0.51)	215 (8.46)	192 (7.56)	4 (0.16)	138 (5.43)	96 (3.78)	80 (3.15)	14 (0.55)	185 (7.28)	113 (4.45)	153 (6.02)	204 (8.03)	113 (4.45)	172 (6.77)
	1FK7101-5												211 (8.31)	139 (5.47)	179 (7.05)	240 (9.45)	139 (5.47)	208 (8.19)
	1FK7103-5												237 (9.33)	165 (6.50)	205 (8.07)	266 (10.47)	165 (6.50)	234 (9.21)
	1FK7105-5												289 (11.38)	217 (8.54)	257 (10.12)	318 (12.52)	217 (8.54)	286 (11.26)

Shaft height	Type	Encoder system: Incremental encoder IC2048S/R / IC22DQ Absolute encoder AM2048S/R / AM22DQ AM32S/R / AM16DQ						Shaft extension DE				
		without brake			with brake			d D	d ₆ -	l E	t GA	u F
		k LB	o ₁ -	o ₂ -	k LB	o ₁ -	o ₂ -					
80	1FK7080-5	179 (7.05)	91 (3.58)	124 (4.88)	206 (8.11)	91 (3.58)	151 (5.94)	32 (1.26)	M12	58 (2.28)	35 (1.38)	10 (0.39)
	1FK7083-5	217 (8.54)	129 (5.08)	162 (6.38)	268 (10.55)	153 (6.02)	213 (8.39)					
100	1FK7100-5	208 (8.19)	113 (4.45)	153 (6.02)	227 (8.94)	113 (4.45)	172 (6.77)	38 (1.50)	M12	80 (3.15)	41 (1.61)	10 (0.39)
	1FK7101-5	234 (9.21)	139 (5.47)	179 (7.05)	263 (10.35)	139 (5.47)	208 (8.19)					
	1FK7103-5	260 (10.24)	165 (6.50)	205 (8.07)	289 (11.38)	165 (6.50)	234 (9.21)					
	1FK7105-5	312 (12.28)	217 (8.54)	257 (10.12)	341 (13.43)	217 (8.54)	286 (11.26)					

1FK708.-5

Shaft design with fitted key

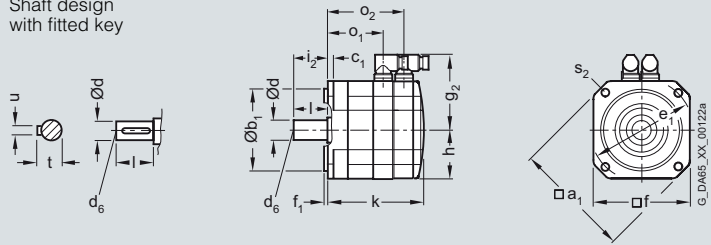

1FK7100-5
1FK7101-5
1FK7103-5
1FK7105-5

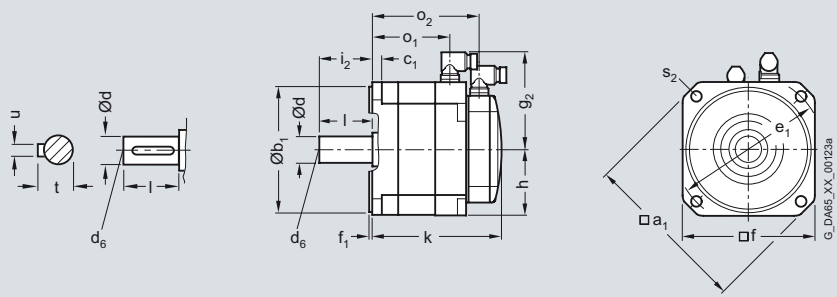

Servomotors

Dimensional drawings

1FK7 High Dynamic motors with/without DRIVE-CLiQ – Natural cooling

Dimensional drawings

For motor Dimensions in mm (inches)

Shaft height	Type	DIN IEC	a ₁ P	b ₁ N	c ₁ LA	e ₁ M	f AB	f ₁ T	g ₂ –	h H	i ₂ –	s ₂ S	Encoder system: Resolver Absolute encoder AM16S/R / AM15DQ without/with brake		
													k LB	o ₁ –	o ₂ –
1FK7 High Dynamic, type of construction IM B5, natural cooling, with connector, with/without brake															
36	1FK7033-7		92 (3.62)	60 (2.36)	8 (0.31)	75 (2.95)	72 (2.83)	3 (0.12)	78 (3.07)	36 (1.42)	30 (1.18)	6.5 (0.26)	170/195 (6.69/7.68)	108/108 (4.25/4.25)	145/170 (5.71/6.69)
48	1FK7043-7		120 (4.72)	80 (3.15)	10 (0.39)	100 (3.94)	96 (3.78)	3 (0.12)	90 (3.54)	48 (1.89)	40 (1.57)	7 (0.28)	191/220 (7.52/8.66)	130/130 (5.12/5.12)	163/192 (6.42/7.56)
	1FK7044-7												216/245 (8.51/9.65)	155/155 (6.10/6.10)	188/217 (7.40/8.54)
63	1FK7061-7		155 (6.10)	110 (4.33)	10 (0.39)	130 (5.12)	126 (4.96)	3.5 (0.14)	105 (4.13)	63 (2.48)	50 (1.97)	9 (0.35)	185/228 (7.28/8.98)	121/121 (4.76/4.76)	153/196 (6.02/7.72)
	1FK7064-7												249/292 (9.80/11.50)	185/185 (7.28/7.28)	217/260 (8.54/10.24)
80	1FK7085-7		186 (7.32)	130 (5.12)	13 (0.51)	165 (6.50)	155 (6.10)	3.5 (0.14)	141.5 (5.57)	77.5 (3.05)	58 (2.28)	11 (0.43)	261/303 (10.28/11.93)	192/192 (7.56/7.56)	229/272 (9.02/10.71)
	1FK7086-7								140.5 (5.53)						

Encoder system:
Incremental encoder IC2048S/R / IC22DQ
Absolute encoder AM2048S/R / AM22DQ
AM512S/R / AM20DQ
AM32S/R / AM16DQ
without/with brake

Shaft extension DE

Shaft height	Type	DIN IEC	k LB	o ₁ –	o ₂ –	Shaft extension DE				
						d D	d ₆ –	l E	t GA	u F
36	1FK7033-7		194/219 (7.64/8.62)	109/109 (4.29/4.29)	144/168 (5.67/6.61)	14 (0.55)	M5	30 (1.18)	16 (0.63)	5 (0.20)
48	1FK7043-7		212/241 (8.35/9.49)	130/130 (5.12/5.12)	163/192 (6.42/7.56)	19 (0.75)	M6	40 (1.57)	21.5 (0.85)	6 (0.24)
	1FK7044-7		237/266 (9.33/10.47)	155/155 (6.10/6.10)	188/217 (7.40/8.54)					
63	1FK7061-7		208/251 (8.19/9.88)	121/121 (4.76/4.76)	154/197 (6.06/7.76)	24 (0.94)	M8	50 (1.97)	27 (1.06)	8 (0.31)
	1FK7064-7		272/315 (10.71/12.40)	185/185 (7.28/7.28)	218/261 (8.58/10.28)					
80	1FK7085-7		283/326 (11.14/12.83)	192/192 (7.56/7.56)	229/272 (9.02/10.71)	32 (1.26)	M12	58 (2.28)	35 (1.38)	10 (0.39)
	1FK7086-7									

1FK703.-7
1FK704.-7
1FK706.-7
1FK708.-7

Shaft design with fitted key

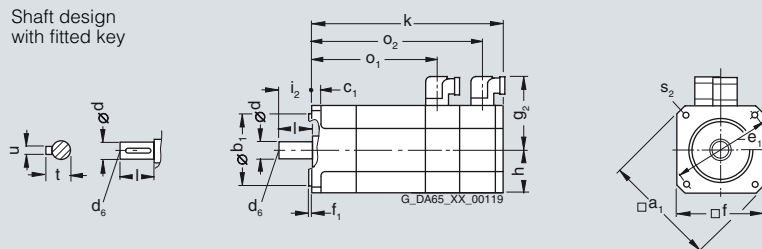

Dimensional drawings

For motor Dimensions in mm (inches)

Shaft height	Type	DIN IEC	a ₁ P	b ₁ N	c ₁ LA	e ₁ M	f AB	f ₁ T	g ₁ –	g ₂ –	i ₂ –	s ₂ S	Encoder system:					
													Incremental encoder			Absolute encoder		
													without brake			with brake		
													k LB	o ₁ –	o ₂ –	k LB	o ₁ –	o ₂ –
1FK7 High Inertia, natural cooling, with connector, with/without brake																		
48	1FK7042-3B		120 (4.72)	80 (3.15)	10 (0.39)	100 (3.94)	96 (3.78)	3 (0.12)	94 (3.7)	90 (3.54)	40 (1.57)	6.5 (0.26)	192 (7.56)	125 (4.92)	177 (6.97)	224 (8.82)	157 (6.18)	209 (8.23)
63	1FK7060-3B		155 (6.1)	110 (4.33)	10 (0.39)	130 (5.12)	126 (4.96)	3.5 (0.14)	102 (4.02)	104 (4.09)	50 (1.97)	9 (0.35)	187 (7.36)	120 (4.72)	172 (6.77)	222 (8.74)	155 (6.1)	207 (8.15)
	1FK7062-3B												221 (8.7)	153 (6.02)	205 (8.07)	256 (10.08)	189 (7.44)	241 (9.49)
80	1FK7081-3B		194 (7.64)	130 (5.12)	11.5 (0.45)	165 (6.5)	155 (6.1)	3.5 (0.14)	94 (3.7)	119 (4.69)	58 (2.28)	11 (0.43)	216 (8.5)	151 (5.94)	201 (7.91)	269 (10.59)	203 (7.99)	253 (9.96)
	1FK7084-3B												275 (10.8)	209 (8.23)	259 (10.2)	327 (12.87)	262 (10.3)	312 (12.28)

Shaft extension DE

Shaft height	Type	d D	d ₆ –	l E	t GA	u F
48	1FK7042-3B	19 (0.75)	M6	40 (1.57)	21.5 (0.85)	6 (0.24)
63	1FK7060-3B	24 (0.94)	M8	50 (1.97)	27 (1.06)	8 (0.31)
	1FK7062-3B					
80	1FK7081-3B	32 (1.26)	M12	58 (2.28)	35 (1.38)	10 (0.38)
	1FK7084-3B					

1FK7042-3B
1FK706.-3B
1FK708.-3B

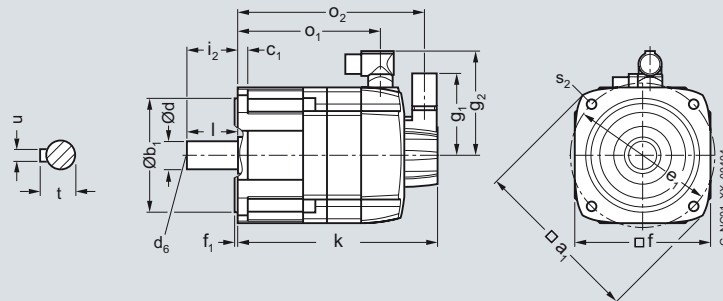

Servomotors

Dimensional drawings

1FT7 Compact motors with/without DRIVE-CLiQ with SP+ planetary gearbox, single-stage

Dimensional drawings

For motors		Dimensions in mm (inches)											Encoder system:	
Shaft height	Type	F4	Planetary gearbox Type	D1	D2	D3	D4	L5	L6	L7	L8	Incremental encoder		
												without brake	with brake	
1FT7 Compact with SP+ planetary gearbox, single-stage, type of construction IM B5, natural cooling, with connector, with/without brake														
36	1FT7034	62 (2.44)	SP060S-MF1	60 (2.36)	16 (0.63)	5.5 (0.22)	68 (2.68)	142 (5.59)	28 (1.10)	20 (0.79)	6 (0.24)	347 (13.66)	374 (14.72)	
	1FT7034	76 (2.99)	SP075S-MF1	70 (2.76)	22 (0.87)	6.6 (0.26)	85 (3.35)	163.8 (6.45)	36 (1.42)	20 (0.79)	7 (0.28)	361 (14.21)	388 (15.28)	
	1FT7036											297 (11.69)	324 (12.76)	
48	1FT7042							167.5 (6.59)				275 (10.83)	307 (12.09)	
	1FT7044											325 (12.80)	357 (14.06)	
	1FT7046											365 (14.37)	397 (15.63)	
	1FT7046	101 (3.98)	SP100S-MF1	90 (3.54)	32 (1.26)	9 (0.35)	120 (4.72)	210 (8.27)	58 (2.28)	30 (1.18)	10 (0.39)	375 (14.76)	407 (16.02)	
63	1FT7062							217 (8.54)				296 (11.65)	331 (13.03)	
	1FT7064											327 (12.87)	362 (14.25)	
	1FT7066											359 (14.13)	394 (15.51)	
	1FT7068											406 (15.98)	441 (17.36)	
	1FT7068	141 (5.55)	SP140S-MF1	130 (5.12)	40 (1.57)	11 (0.43)	165 (6.50)	274.3 (10.80)	82 (3.23)	30 (1.18)	12 (0.47)	439 (17.28)	474 (18.66)	
80	1FT7082							283.3 (11.15)				361 (14.21)	413 (16.26)	
	1FT7084											412 (16.22)	464 (18.27)	
	1FT7086											464 (18.27)	516 (20.31)	
	1FT7086	182 (7.17)	SP180S-MF1	160 (6.30)	55 (2.17)	13.5 (0.53)	215 (8.46)	310 (12.20)	82 (3.23)	30 (1.18)	15 (0.59)	491 (19.33)	543 (21.38)	
100	1FT7102											412 (16.22)	464 (18.27)	
	1FT7105											498 (19.61)	550 (21.65)	
	1FT7108											568 (22.36)	620 (24.41)	
	1FT7105	215 (8.46)	SP210S-MF1	180 (7.09)	75 (2.95)	17 (0.67)	250 (9.84)	385 (15.16)	105 (4.13)	38 (1.50)	17 (0.67)	542 (21.34)	594 (23.39)	
	1FT7108											612 (24.09)	664 (26.14)	

1FT703
1FT704
1FT706
1FT708
1FT710

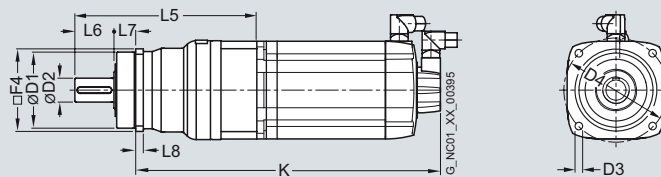

Servomotors

Dimensional drawings

1FT7 Compact motors with/without DRIVE-CLiQ with SP+ planetary gearbox, 2-stage

Dimensional drawings

For motor		Dimensions in mm (inches)										Encoder system:	
Shaft height	Type	F4	Planetary gearbox Type	D1	D2	D3	D4	L5	L6	L7	L8	Incremental encoder	Absolute encoder
												without brake	with brake
1FT7 Compact with SP+ planetary gearbox, 2-stage, type of construction IM B5, natural cooling, with connector, with/without brake													
36	1FT7034	76 (2.99)	SP075S-MF2	70 (2.76)	22 (0.87)	6.6 (0.26)	85 (3.35)	179.4 (7.06)	36 (1.42)	20 (0.79)	7 (0.28)	376 (14.80)	403 (15.87)
	1FT7036											312 (12.28)	339 (13.35)
48	1FT7042							192 (7.56)				331 (13.03)	331 (13.03)
36	1FT7034	101 (3.98)	SP100S-MF2	90 (3.54)	32 (1.26)	9 (0.35)	120 (4.72)	230.3 (9.07)	58 (2.28)	30 (1.18)	10 (0.39)	395 (15.55)	422 (16.61)
	1FT7036											331 (13.03)	358 (14.09)
48	1FT7042							234 (9.21)				341 (13.43)	341 (13.43)
	1FT7044											359 (14.13)	391 (15.39)
	1FT7046											431 (16.97)	431 (16.97)
	1FT7044	141 (5.55)	SP140S-MF2	130 (5.12)	40 (1.58)	11 (0.43)	165 (6.50)	298.3 (11.74)	82 (3.23)	30 (1.18)	12 (0.47)	399 (15.71)	431 (16.97)
1FT7046	471 (18.54)											471 (18.54)	

1FT703
1FT704

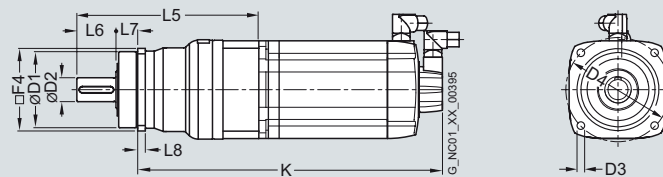

Servomotors

Dimensional drawings

1FT7 Compact motors with/without DRIVE-CLiQ with SP+ planetary gearbox, 2-stage

Dimensional drawings

For motor		Dimensions in mm (inches)										Encoder system:	
Shaft height	Type	F4	Planetary gearbox Type	D1	D2	D3	D4	L5	L6	L7	L8	Incremental encoder	
												without brake K	with brake K
1FT7 Compact with SP+ planetary gearbox, 2-stage, type of construction IM B5, natural cooling, with connector, with/without brake													
63	1FT7062	101 (3.98)	SP100S-MF2	90 (3.54)	32 (1.26)	9 (0.35)	120 (4.72)	252 (9.92)	58 (2.28)	30 (1.18)	10 (0.39)	331 (13.03)	366 (14.41)
	1FT7064											362 (14.25)	397 (15.63)
	1FT7062	141 (5.55)	SP140S-MF2	130 (5.12)	40 (1.57)	11 (0.43)	165 (6.50)	305 (12.01)	82 (3.23)	30 (1.18)	12 (0.47)	360 (14.17)	395 (15.55)
	1FT7064											391 (15.39)	426 (16.77)
	1FT7066											458 (18.03)	458 (18.03)
	1FT7068											505 (19.88)	505 (19.88)
80	1FT7082							332 (13.07)				410 (16.14)	462 (18.19)
	1FT7084											461 (18.15)	513 (20.20)
63	1FT7064	182 (7.17)	SP180S-MF2	160 (6.30)	55 (2.17)	13.5 (0.53)	215 (8.46)	346 (13.62)	82 (3.23)	30 (1.18)	15 (0.59)	432 (17.01)	467 (18.39)
	1FT7066											499 (19.65)	499 (19.65)
	1FT7068											546 (21.50)	546 (21.50)
80	1FT7082							355 (13.98)				433 (17.05)	485 (19.09)
	1FT7084											536 (21.10)	536 (21.10)
	1FT7086											536 (21.10)	588 (23.15)
100	1FT7102										457 (17.99)	509 (20.04)	
80	1FT7084	215 (8.46)	SP210S-MF2	180 (7.09)	75 (2.95)	17 (0.67)	250 (9.84)	415 (16.34)	105 (4.13)	38 (1.50)	17 (0.67)	565 (22.24)	565 (22.24)
	1FT7086											617 (24.29)	617 (24.29)
100	1FT7102											538 (21.18)	538 (21.18)
	1FT7105											572 (22.52)	624 (24.57)
	1FT7108											694 (27.32)	694 (27.32)
80	1FT7086	245 (9.65)	SP240S-MF2	200 (7.87)	85 (3.35)	17 (0.67)	290 (11.42)	467.5 (18.41)	130 (5.12)	40 (1.57)	20 (0.79)	643 (25.31)	643 (25.31)
100	1FT7102											512 (20.16)	564 (22.20)
	1FT7105											598 (23.54)	650 (25.59)
	1FT7108											668 (26.30)	720 (28.35)

1FT706
1FT708
1FT710

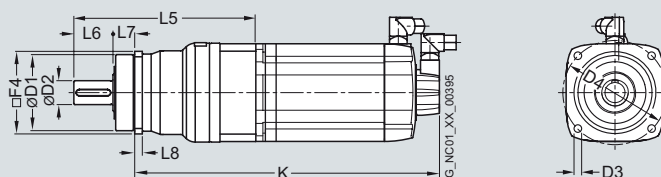

1FK7 Compact motors with/without DRIVE-CLiQ with SP+ planetary gearbox, single-stage

Dimensional drawings

For motor		Dimensions in mm (inches)												Encoder system:			
Shaft height	Type	F4	Planetary gearbox Type	D1	D2	D3	D4	L5	L6	L7	L8	Resolver		Absolute encoder			
												without brake	with brake	without brake	with brake		
												K	K	K	K		
1FK7 Compact with SP+ planetary gearbox, single-stage, type of construction IM B5, natural cooling, with connector, with/without brake																	
28	1FK7022-5	62 (2.44)	SP060S-MF1	60 (2.36)	16 (0.63)	5.5 (0.22)	68 (2.68)	137 (5.39)	28 (1.10)	20 (0.79)	6 (0.24)	242 (9.53)	264 (10.39)	267 (10.51)	289 (11.38)		
36	1FK7032-5	62 (2.44)	SP060S-MF1	60 (2.36)	16 (0.63)	5.5 (0.22)	68 (2.68)	142 (5.59)	28 (1.10)	20 (0.79)	6 (0.24)	244 (9.61)	269 (10.59)	269 (10.59)	294 (11.57)		
	1FK7034-5	269 (10.59)										294 (11.57)	294 (11.57)	319 (12.56)			
48	1FK7040-5	76 (2.99)	SP075S-MF1	70 (2.76)	22 (0.87)	6.6 (0.26)	85 (3.35)	168 (6.61)	36 (1.42)	20 (0.79)	7 (0.28)	246 (9.69)	275 (10.83)	267 (10.51)	296 (11.65)		
	1FK7042-5	274 (10.79)										303 (11.93)	294 (11.57)	323 (12.72)			
63	1FK7060-5	101 (3.98)	SP100S-MF1	90 (3.54)	32 (1.26)	9 (0.35)	120 (4.72)	217 (8.54)	58 (2.28)	30 (1.18)	10 (0.39)	286 (11.26)	329 (12.95)	309 (12.17)	352 (13.86)		
	1FK7063-5	331 (13.03)										374 (14.72)	354 (13.94)	397 (15.63)			
80	1FK7080-5	141 (5.55)	SP140S-MF1	130 (5.12)	40 (1.58)	11 (0.43)	165 (6.50)	283 (11.14)	82 (3.23)	30 (1.18)	12 (0.47)	327 (12.87)	355 (13.98)	350 (13.78)	377 (14.84)		
	1FK7083-5	365 (14.37)										416 (16.38)	388 (15.28)	439 (17.28)			
100	1FK7100-5	182 (7.17)	SP180S-MF1	160 (6.30)	55 (2.17)	13.5 (0.53)	215 (8.47)	310 (12.20)	82 (3.23)	30 (1.18)	15 (0.59)	383 (15.08)	402 (15.83)	406 (15.98)	425 (16.73)		
	1FK7101-5	409 (16.10)										438 (17.24)	432 (17.01)	461 (18.15)			
	1FK7103-5	435 (17.13)										464 (18.27)	458 (18.03)	487 (19.17)			
1FK7105-5	182 (7.17)	SP180S-MF1	160 (6.30)	55 (2.17)	13.5 (0.55)	215 (8.47)	310 (12.20)	82 (3.23)	30 (1.18)	15 (0.59)	487 (19.17)	516 (20.31)	510 (20.08)	539 (21.22)			
1FK7105-5	215 (8.46)	SP210S-MF1	180 (7.09)	75 (2.95)	17 (0.67)	250 (9.84)	385 (15.16)	105 (4.13)	38 (1.50)	17 (0.67)	531 (20.91)	560 (22.05)	554 (21.81)	583 (22.95)			

1FK702-5
1FK703-5
1FK704-5
1FK706-5
1FK708-5
1FK710-5

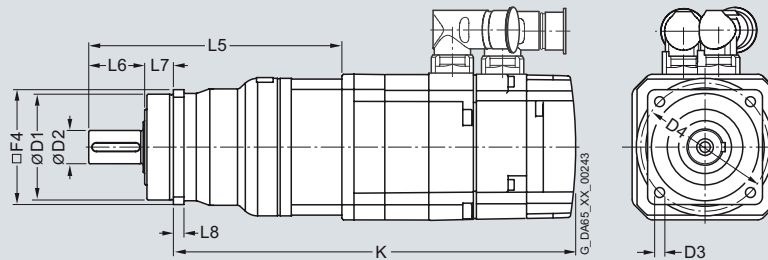

Servomotors

Dimensional drawings

1FK7 High Dynamic motors with/without DRIVE-CLiQ with SP+ planetary gearbox, single-stage

Dimensional drawings

For motor

Dimensions in mm (inches)

Shaft height	Type	F4	Planetary gearbox Type	D1	D2	D3	D4	L5	L6	L7	L8	Encoder system:			
												without brake K	with brake K	without brake K	with brake K
1FK7 High Dynamic with SP+ planetary gearbox, single-stage, type of construction IM B5, natural cooling, with connector, with/without brake													Resolver	Incremental encoder	IC2048S/R
													Absolute encoder	Absolute encoder	AM2048S/R
													AM16S/R		AM22DQ
													AM15DQ		AM512S/R
															AM20DQ
															AM32S/R
															AM16DQ
36	1FK7033-7	62 (2.44)	SP060S-MF1	60 (2.36)	16 (0.63)	5.5 (0.22)	68 (2.68)	142 (5.59)	28 (1.10)	20 (0.79)	6 (0.24)	263 (10.35)	288 (11.34)	288 (11.34)	313 (12.32)
48	1FK7043-7	76 (2.99)	SP075S-MF1	70 (2.76)	22 (0.87)	6.6 (0.26)	85 (3.35)	168 (6.61)	36 (1.42)	20 (0.79)	7 (0.28)	303 (11.93)	332 (13.07)	324 (12.76)	353 (13.90)
	1FK7044-7	328 (12.91)										357 (14.06)	349 (13.74)	378 (14.88)	
63	1FK7061-7	101 (3.98)	SP100S-MF1	90 (3.54)	32 (1.26)	9 (0.35)	120 (4.72)	217 (8.54)	58 (2.28)	30 (1.18)	10 (0.39)	314 (12.36)	357 (14.06)	337 (13.27)	380 (14.96)
	1FK7064-7	378 (14.88)										421 (16.57)	401 (15.79)	444 (17.48)	
80	1FK7085-7	141 (5.55)	SP140S-MF1	130 (5.12)	40 (1.57)	11 (0.43)	165 (6.50)	283 (11.14)	82 (3.23)	30 (1.18)	12 (0.47)	432 (17.01)	474 (18.66)	454 (17.87)	497 (19.57)
	1FK7086-7														

1FK703.-7
1FK704.-7
1FK706.-7
1FK708.-7

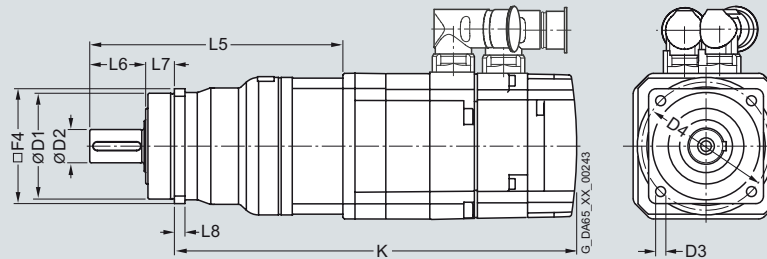

1FK7 Compact motors with/without DRIVE-CLiQ with SP+ planetary gearbox, two-stage

Dimensional drawings

For motor		Dimensions in mm (inches)												Encoder system:			
Shaft height	Type	F4	Planetary gearbox Type	D1	D2	D3	D4	L5	L6	L7	L8	without brake		with brake			
												K	K	K	K		
1FK7 Compact with SP+ planetary gearbox, two-stage, type of construction IM B5, natural cooling, with connector, with/without brake																	
28	1FK7022-5	62	SP060S-MF2	60	16	5.5	68	156	28	20	6	261	283	286	308		
		(2.44)		(2.36)	(0.63)	(0.22)	(2.68)	(6.14)	(1.10)	(0.79)	(0.24)	(10.28)	(11.14)	(11.26)	(12.13)		
		76	SP075S-MF2	70	22	6.6	85	175	36	20	7	272	294	297	319		
		(2.99)		(2.76)	(0.87)	(0.26)	(3.35)	(6.89)	(1.42)	(0.79)	(0.28)	(10.71)	(11.57)	(11.69)	(12.56)		
		101	SP100S-MF2	90	32	9	120	230	58	30	10	295	317	320	342		
		(3.98)		(3.54)	(1.26)	(0.35)	(4.72)	(9.06)	(2.28)	(1.18)	(0.39)	(11.61)	(12.48)	(12.60)	(13.46)		
36	1FK7032-5	62	SP060S-MF2	60	16	5.5	68	164	28	20	6	266	291	291	316		
		(2.44)		(2.36)	(0.63)	(0.22)	(2.68)	(6.46)	(1.10)	(0.79)	(0.24)	(10.47)	(11.46)	(11.46)	(12.44)		
		76	SP075S-MF2	70	22	6.6	85	179	36	20	7	273	298	298	323		
	(2.99)		(2.76)	(0.87)	(0.26)	(3.35)	(7.05)	(1.42)	(0.79)	(0.28)	(10.75)	(11.73)	(11.73)	(12.72)			
			101	SP100S-MF2	90	32	9	120	230	58	30	10	292	317	317	342	
			(3.98)		(3.54)	(1.26)	(0.35)	(4.72)	(9.06)	(2.28)	(1.18)	(0.39)	(11.50)	(12.48)	(12.48)	(13.46)	
	1FK7034-5	76	SP075S-MF2	70	22	6.6	85	179	36	20	7	298	323	323	348		
(2.99)			(2.76)	(0.87)	(0.26)	(3.35)	(7.05)	(1.42)	(0.79)	(0.28)	(11.73)	(12.72)	(12.72)	(13.70)			
101		SP100S-MF2	90	32	9	120	230	58	30	10	317	342	342	367			
		(3.98)		(3.54)	(1.26)	(0.35)	(4.72)	(9.06)	(2.28)	(1.18)	(0.39)	(12.48)	(13.46)	(13.46)	(14.45)		
48	1FK7040-5	76	SP075S-MF2	70	22	6.6	85	192	36	20	7	270	299	291	320		
		(2.99)		(2.76)	(0.87)	(0.26)	(3.35)	(7.56)	(1.42)	(0.79)	(0.28)	(10.63)	(11.77)	(11.46)	(12.60)		
		101	SP100S-MF2	90	32	9	120	234	58	30	10	280	309	301	330		
	(3.98)		(3.54)	(1.26)	(0.35)	(4.72)	(9.21)	(2.28)	(1.18)	(0.39)	(11.02)	(12.17)	(11.85)	(12.99)			
			141	SP140S-MF2	130	40	11	165	298	82	30	12	320	349	341	370	
			(5.55)		(5.12)	(1.57)	(0.43)	(6.50)	(11.73)	(3.23)	(1.18)	(0.47)	(12.60)	(13.74)	(13.43)	(14.57)	
	1FK7042-5	76	SP075S-MF2	70	22	6.6	85	192	36	20	7	298	327	298	347		
(2.99)			(2.76)	(0.87)	(0.26)	(3.35)	(7.56)	(1.42)	(0.79)	(0.28)	(11.73)	(12.87)	(11.73)	(13.66)			
101		SP100S-MF2	90	32	9	120	234	58	30	10	308	337	308	357			
		(3.98)		(3.54)	(1.26)	(0.35)	(4.72)	(9.21)	(2.28)	(1.18)	(0.39)	(12.13)	(13.27)	(12.13)	(14.06)		
		141	SP140S-MF2	130	40	11	165	298	82	30	12	348	377	368	397		
		(5.55)		(5.12)	(1.57)	(0.43)	(6.50)	(11.73)	(3.23)	(1.18)	(0.47)	(13.71)	(14.84)	(14.49)	(15.63)		
63	1FK7060-5	101	SP100S-MF2	90	32	9	120	252	58	30	10	321	364	344	387		
		(3.98)		(3.54)	(1.26)	(0.35)	(4.72)	(9.92)	(2.28)	(1.18)	(0.39)	(12.64)	(14.33)	(13.54)	(15.24)		
			141	SP140S-MF2	130	40	11	165	305	82	30	12	350	393	373	416	
			(5.55)		(5.12)	(1.57)	(0.43)	(6.50)	(12.01)	(3.23)	(1.18)	(0.47)	(13.78)	(15.47)	(14.69)	(16.38)	
	1FK7063-5	141	SP140S-MF2	130	40	11	165	305	82	30	12	395	438	418	461		
(5.55)			(5.12)	(1.57)	(0.43)	(6.50)	(12.01)	(3.23)	(1.18)	(0.47)	(15.55)	(17.24)	(16.46)	(18.15)			
		182	SP180S-MF2	160	55	13.5	215	346	82	30	15	436	479	459	502		
		(7.17)		(6.30)	(2.17)	(0.53)	(8.46)	(13.62)	(3.23)	(1.18)	(0.59)	(17.17)	(18.86)	(18.07)	(19.76)		

1FK702.-5
1FK703.-5
1FK704.-5
1FK706.-5

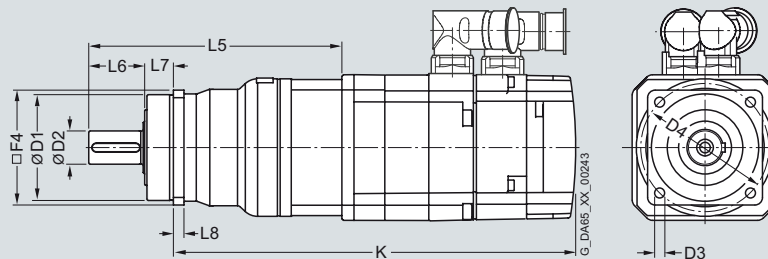

Servomotors

Dimensional drawings

1FK7 Compact motors with/without DRIVE-CLiQ with SP+ planetary gearbox, two-stage

Dimensional drawings

For motor

Dimensions in mm (inches)

Shaft height	Type	F4	Planetary gearbox Type	D1	D2	D3	D4	L5	L6	L7	L8	Encoder system: Resolver			
												without brake K	with brake K	without brake K	with brake K
													Incremental encoder	IC2048S/R IC22DQ AM2048S/R AM22DQ AM32S/R AM16DQ	

1FK7 Compact with SP+ planetary gearbox, two-stage, type of construction IM B5, natural cooling, with connector, with/without brake

80	1FK7080-5	141	SP140S-MF2	130	40	11	165	332	82	30	12	376	404	399	426
		(5.55)		(5.12)	(1.57)	(0.43)	(6.50)	(13.07)	(3.23)	(1.18)	(0.47)	(14.80)	(15.91)	(15.71)	(16.77)
		182	SP180S-MF2	160	55	13.5	215	355	82	30	15	399	427	422	449
	(7.17)		(6.30)	(2.17)	(0.53)	(8.46)	(13.98)	(3.23)	(1.18)	(0.59)	(15.71)	(16.81)	(16.61)	(17.68)	
	215	SP210S-MF2	180	75	17	250	415	105	38	17	428	456	451	478	
	(8.46)		(7.09)	(2.95)	(0.67)	(9.84)	(16.34)	(4.13)	(1.50)	(0.67)	(16.85)	(17.95)	(17.76)	(18.82)	
80	1FK7083-5	141	SP140S-MF2	130	40	11	165	332	82	30	12	414	465	437	488
		(5.55)		(5.12)	(1.57)	(0.43)	(6.50)	(13.07)	(3.23)	(1.18)	(0.47)	(16.30)	(18.31)	(17.20)	(19.21)
		182	SP180S-MF2	160	55	13.5	215	355	82	30	15	437	488	460	511
	(7.17)		(6.30)	(2.17)	(0.53)	(8.46)	(13.98)	(3.23)	(1.18)	(0.59)	(17.20)	(19.21)	(18.11)	(20.12)	
	215	SP210S-MF2	180	75	17	250	415	105	38	17	466	517	489	540	
	(8.46)		(7.09)	(2.95)	(0.67)	(9.84)	(16.34)	(4.13)	(1.50)	(0.67)	(18.35)	(20.35)	(19.25)	(21.26)	
100	1FK7100-5	182	SP180S-MF2	160	55	13.5	215	310	82	30	15	383	402	406	425
		(7.17)		(6.30)	(2.17)	(0.53)	(8.46)	(12.20)	(3.23)	(1.18)	(0.59)	(15.08)	(15.83)	(15.98)	(16.73)
	215	SP210S-MF2	180	75	17	250	415	105	38	17	457	476	480	499	
	(8.46)		(7.09)	(2.95)	(0.67)	(9.84)	(16.34)	(4.13)	(1.50)	(0.67)	(17.99)	(18.74)	(18.90)	(19.65)	
	1FK7101-5	182	SP180S-MF2	160	55	13.5	215	310	82	30	15	409	438	432	461
		(7.17)		(6.30)	(2.17)	(0.53)	(8.46)	(12.20)	(3.23)	(1.18)	(0.59)	(16.10)	(17.24)	(17.01)	(18.15)
215		SP210S-MF2	180	75	17	250	415	105	38	17	483	512	506	535	
(8.46)		(7.09)	(2.95)	(0.67)	(9.84)	(16.34)	(4.13)	(1.50)	(0.67)	(19.02)	(20.16)	(19.92)	(21.06)		
245	SP240S-MF2	200	85	17	290	467.5	130	40	20	509	538	531	561		
(9.65)		(7.87)	(3.35)	(0.67)	(11.42)	(18.41)	(5.12)	(1.57)	(0.79)	(20.04)	(21.18)	(20.91)	(22.09)		
1FK7103-5	182	SP180S-MF2	160	55	13.5	215	310	82	30	15	435	464	458	487	
	(7.17)		(6.30)	(2.17)	(0.53)	(8.46)	(12.20)	(3.23)	(1.18)	(0.59)	(17.13)	(18.27)	(18.03)	(19.19)	
	215	SP210S-MF2	180	75	17	250	415	105	38	17	509	538	532	561	
(8.46)		(7.09)	(2.95)	(0.67)	(9.84)	(16.34)	(4.13)	(1.50)	(0.67)	(20.04)	(21.18)	(20.94)	(22.09)		
245	SP240S-MF2	200	85	17	290	467.5	130	40	20	535	564	557	587		
(9.56)		(7.87)	(3.35)	(0.67)	(11.42)	(18.41)	(5.12)	(1.57)	(0.79)	(21.06)	(22.20)	(21.93)	(23.11)		
1FK7105-5	215	SP210S-MF2	180	75	17	250	415	105	38	17	561	590	584	613	
	(8.46)		(7.09)	(2.95)	(0.67)	(9.84)	(16.34)	(4.13)	(1.50)	(0.67)	(22.09)	(23.23)	(22.99)	(24.13)	
245	SP240S-MF2	200	85	17	290	467.5	130	40	20	587	616	610	639		
(9.65)		(7.87)	(3.35)	(0.67)	(11.42)	(18.41)	(5.12)	(1.57)	(0.79)	(23.11)	(24.25)	(24.02)	(25.16)		

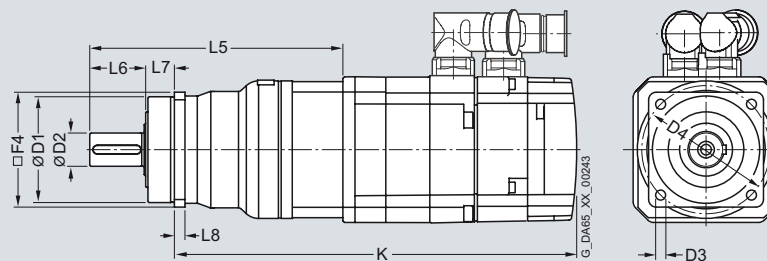
1FK708.-5
1FK710.-5

1FK7 High Dynamic motors with/without DRIVE-CLiQ with SP+ planetary gearbox, two-stage

Dimensional drawings

For motor		Dimensions in mm (inches)												Encoder system:					
Shaft height	Type	F4	Planetary gearbox Type	D1	D2	D3	D4	L5	L6	L7	L8	K	K	K	K	Resolver	Incremental encoder	IC2048S/R	
																Absolute encoder	Absolute encoder	IC22DQ	
																AM16S/R	Absolute encoder	AM2048S/R	
																AM15DQ		AM22DQ	
																		AM512S/R	
																		AM20DQ	
																		AM32S/R	
																		AM16DQ	
																without brake	with brake	without brake	with brake
1FK7 High Dynamic with SP+ planetary gearbox, two-stage, type of construction IM B5, natural cooling, with connector, with/without brake																			
36	1FK7033-7	62	SP060S-MF2	60	16	5.5	68	164	28	20	6	285	310	310	335				
		(2.44)		(2.36)	(0.63)	(0.22)	(2.68)	(6.46)	(1.10)	(0.79)	(0.24)	(11.22)	(12.20)	(12.20)	(13.19)				
		76	SP075S-MF2	70	22	6.6	85	179	36	20	7	292	317	317	342				
		(2.99)		(2.76)	(0.87)	(0.26)	(3.35)	(7.05)	(1.42)	(0.79)	(0.28)	(11.50)	(12.48)	(12.48)	(13.46)				
		101	SP100S-MF2	90	32	9	120	230	58	30	10	311	336	336	361				
		(3.98)		(3.54)	(1.26)	(0.35)	(4.72)	(9.06)	(2.28)	(1.18)	(0.39)	(12.24)	(13.23)	(13.23)	(14.21)				
48	1FK7043-7	76	SP075S-MF2	70	22	6.6	85	192	36	20	7	327	356	348	377				
		(2.99)		(2.76)	(0.87)	(0.26)	(3.35)	(7.56)	(1.42)	(0.79)	(0.28)	(12.87)	(14.02)	(13.70)	(14.84)				
		101	SP100S-MF2	90	32	9	120	234	58	30	10	337	366	358	387				
		(3.98)		(3.54)	(1.26)	(0.35)	(4.72)	(9.21)	(2.28)	(1.18)	(0.39)	(13.27)	(14.41)	(14.09)	(15.24)				
		141	SP140S-MF2	130	40	11	165	298	82	30	12	377	406	398	427				
		(5.55)		(5.12)	(1.57)	(0.43)	(6.50)	(11.74)	(3.23)	(1.18)	(0.47)	(14.84)	(15.98)	(15.67)	(16.81)				
63	1FK7044-7	101	SP100S-MF2	90	32	9	120	234	58	30	10	362	391	383	412				
		(3.98)		(3.54)	(1.26)	(0.35)	(4.72)	(9.21)	(2.28)	(1.18)	(0.39)	(14.25)	(15.39)	(15.08)	(16.22)				
		141	SP140S-MF2	130	40	11	165	298	82	30	12	402	431	432	452				
		(5.55)		(5.12)	(1.57)	(0.43)	(6.50)	(11.73)	(3.23)	(1.18)	(0.47)	(15.83)	(16.97)	(17.01)	(17.80)				
63	1FK7061-7	101	SP100S-MF2	90	32	9	120	252	58	30	10	349	392	372	415				
		(3.98)		(3.54)	(1.26)	(0.35)	(4.72)	(9.92)	(2.28)	(1.18)	(0.39)	(13.74)	(15.43)	(14.65)	(16.34)				
	1FK7064-7	141	SP140S-MF2	130	40	11	165	305	82	30	12	378	421	401	444				
		(5.55)		(5.12)	(1.57)	(0.43)	(6.50)	(12.01)	(3.23)	(1.18)	(0.47)	(14.88)	(16.57)	(15.79)	(17.48)				
											442	485	465	508					
		(7.17)		(6.30)	(2.17)	(0.55)	(8.46)	(13.62)	(3.23)	(1.18)	(0.59)	(19.02)	(20.71)	(19.92)	(21.61)				
80	1FK7064-7	182	SP180S-MF2	160	55	14	215	346	82	30	15	483	526	506	549				
		(7.17)		(6.30)	(2.17)	(0.53)	(8.46)	(13.98)	(3.23)	(1.18)	(0.59)	(19.84)	(21.50)	(20.71)	(22.40)				
	1FK7085-7	215	SP210S-MF2	180	75	17	250	415	105	38	17	533	575	555	598				
		(8.46)		(7.09)	(2.95)	(0.67)	(9.84)	(16.34)	(4.13)	(1.50)	(0.67)	(20.98)	(22.64)	(21.85)	(23.54)				
1FK7086-7	182	SP180S-MF2	160	55	13.5	215	355	82	30	15	504	546	526	569					
	(7.17)		(6.30)	(2.17)	(0.53)	(8.46)	(13.98)	(3.23)	(1.18)	(0.59)	(19.84)	(21.50)	(20.71)	(22.40)					
		215	SP210S-MF2	180	75	17	250	415	105	38	17	533	575	555	598				
		(8.46)		(7.09)	(2.95)	(0.67)	(9.84)	(16.34)	(4.13)	(1.50)	(0.67)	(20.98)	(22.64)	(21.85)	(23.54)				

1FK703.-7
1FK704.-7
1FK706.-7
1FK708.-7

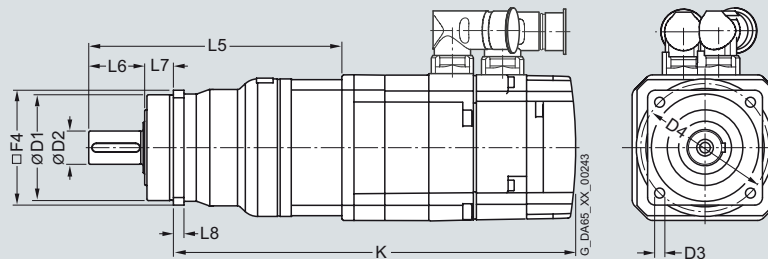

Servomotors

Dimensional drawings

1FK7 Compact motors with/without DRIVE-CLiQ with LP+ planetary gearbox, single-stage

Dimensional drawings

For motor			Dimensions in mm (inches)												
Shaft height	Type	Planetary gearbox Type													
			D ₁	D ₂	D ₃	D ₄	D ₅	L ₂	L ₃	L ₄	L ₅	L ₈	L ₉	L ₁₀	L ₁₆
1FK7 Compact with LP+ planetary gearbox, single-stage, type of construction IM B5, natural cooling, with connector, with/without brake															
28	1FK7022-5	LP050-MO1	50 (1.97)	35 (1.38)	12 (0.47)	44 (1.73)	M4	18 (0.71)	4 (0.16)	7 (0.28)	8 (0.31)	14 (0.55)	4 (0.16)	50 (1.97)	88 (3.46)
	1FK7022-5	LP070-MO1	70 (2.76)	52 (2.05)	16 (0.63)	62 (2.44)	M5	28 (1.10)	5 (0.20)	8 (0.31)	10 (0.39)	18 (0.71)	5 (0.20)	70 (2.76)	119 (4.69)
36	1FK7032-5	LP070-MO1	70 (2.76)	52 (2.05)	16 (0.63)	62 (2.44)	M5	28 (1.10)	5 (0.20)	8 (0.31)	10 (0.39)	18 (0.71)	5 (0.20)	70 (2.76)	126 (4.96)
	1FK7034-5														
48	1FK7040-5	LP090-MO1	90 (3.54)	68 (2.68)	22 (0.87)	80 (3.15)	M6	36 (1.42)	5 (0.20)	10 (0.39)	12 (0.47)	25 (0.98)	6 (0.24)	90 (3.54)	158 (6.22)
	1FK7042-5														
63	1FK7060-5	LP120-MO1	120 (4.72)	90 (3.54)	32 (1.26)	108 (4.25)	M8	58 (2.28)	6 (0.24)	12 (0.47)	16 (0.63)	35 (1.38)	10 (0.39)	120 (4.72)	210 (8.27)
	1FK7063-5														
80	1FK7080-5	LP155-MO1	155 (6.10)	120 (4.72)	40 (1.57)	140 (5.51)	M10	82 (3.23)	8 (0.31)	15 (0.59)	20 (0.79)	43 (1.69)	12 (0.47)	150 (5.91)	266 (10.47)
	1FK7083-5														

Shaft height	Type	DIN IEC	Encoder system:				Incremental encoder IC2048S/R / IC22DQ				l E	d D	a ₁ P
			Resolver		Absolute encoder AM16S/R AM15DQ		Absolute encoder AM2048S/R / AM22DQ		Absolute encoder AM512S/R / AM20DQ AM32S/R / AM16DQ				
			without brake	with brake	without brake	with brake	without brake	with brake					
			k LB	K -	k LB	K -	k LB	K -					
28	1FK7022-5		153 (6.02)	216 (8.50)	175 (6.89)	238 (9.37)	178 (7.01)	241 (9.49)	200 (7.87)	263 (10.35)	20 (0.79)	9 (0.35)	-
	1FK7022-5			236 (9.29)		258 (10.16)		261 (10.28)		283 (11.14)			
36	1FK7032-5		150 (5.91)	240 (9.45)	175 (6.89)	265 (10.43)	175 (6.89)	265 (10.43)	200 (7.87)	290 (11.42)	30 (1.18)	14 (0.55)	92 (3.62)
	1FK7034-5		175 (6.89)	265 (10.43)	200 (7.87)	290 (11.42)	200 (7.87)	290 (11.42)	225 (8.86)	315 (12.40)			
48	1FK7040-5		135 (5.31)	247 (9.72)	164 (6.46)	276 (10.87)	155 (6.10)	267 (10.51)	184 (7.24)	296 (11.65)	40 (1.57)	19 (0.75)	120 (4.72)
	1FK7042-5		162 (6.38)	274 (10.79)	191 (7.52)	303 (11.93)	183 (7.20)	295 (11.61)	212 (8.35)	324 (12.76)			
63	1FK7060-5		157 (6.18)	297 (11.69)	200 (7.87)	340 (13.39)	180 (7.09)	320 (12.60)	223 (8.78)	363 (14.29)	50 (1.97)	24 (0.94)	155 (6.10)
	1FK7063-5		202 (7.95)	342 (13.46)	245 (9.65)	385 (15.16)	225 (8.86)	365 (14.37)	268 (10.55)	408 (16.06)			
80	1FK7080-5		156 (6.14)	325 (12.80)	184 (7.24)	353 (13.90)	179 (7.05)	347 (13.66)	206 (8.11)	375 (14.76)	58 (2.28)	32 (1.26)	186 (7.32)
	1FK7083-5		194 (7.64)	363 (14.29)	245 (9.65)	414 (16.30)	217 (8.54)	385 (15.16)	268 (10.55)	436 (17.17)			

1FK702.-5
1FK703.-5
1FK704.-5
1FK706.-5
1FK708.-5

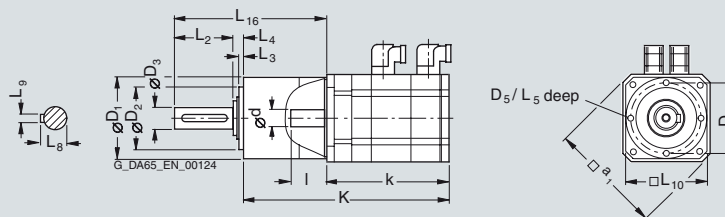

Servomotors

Dimensional drawings

1FK7 Compact motors with/without DRIVE-CLiQ with LP+ planetary gearbox, single-stage

Dimensional drawings

For motor		Dimensions in mm (inches)													
Shaft height	Type	Planetary gearbox Type	D ₁	D ₂	D ₃	D ₄	D ₅	L ₂	L ₃	L ₄	L ₅	L ₈	L ₉	L ₁₀	L ₁₆
			1FK7 Compact with LP+ planetary gearbox, single-stage, type of construction IM B5, natural cooling, with connector, with/without brake												
100	1FK710-5	LP155-MO1	155 (6.10)	120 (4.72)	40 (1.57)	140 (5.51)	M10	82 (3.23)	8 (0.31)	15 (0.59)	20 (0.79)	43 (1.69)	12 (0.47)	150 (5.91)	286 (11.26)

Shaft height	Type	DIN IEC	Encoder system:				Incremental encoder				l E	d D	a ₁ P		
			Resolver		with brake		without brake		with brake						
			k LB	K -	k LB	K -	k LB	K -	k LB	K -					
1FK7100-5															
100	1FK7100-5		185 (7.28)	374 (14.72)	204 (8.03)	393 (15.47)	208 (8.19)	396 (15.59)	227 (8.94)	415 (16.34)	80 (3.15)	38 (1.50)	240 (9.45)		
1FK7101-5															
	1FK7101-5		211 (8.31)	400 (15.75)	240 (9.45)	429 (16.89)	234 (9.21)	422 (16.61)	263 (10.35)	452 (17.80)					
1FK7103-5															
	1FK7103-5		237 (9.33)	426 (16.77)	266 (10.47)	455 (17.91)	260 (10.24)	448 (17.64)	289 (11.38)	478 (18.82)					
1FK7105-5															
	1FK7105-5		289 (11.38)	478 (18.82)	318 (12.52)	507 (19.96)	312 (12.28)	500 (19.69)	341 (13.43)	530 (20.87)					

1FK710-5

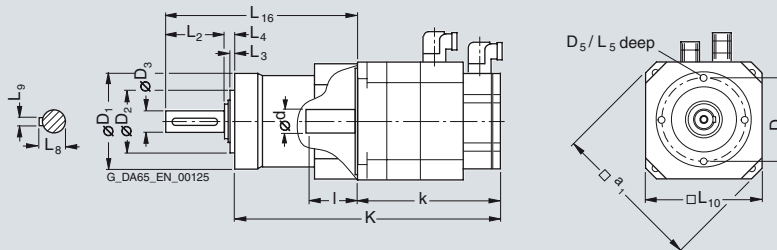

Servomotors

Dimensional drawings

1FK7 High Dynamic motors with/without DRIVE-CLiQ with LP+ planetary gearbox, single-stage

Dimensional drawings

For motor			Dimensions in mm (inches)												
Shaft height	Type	Planetary gearbox													
			D ₁	D ₂	D ₃	D ₄	D ₅	L ₂	L ₃	L ₄	L ₅	L ₈	L ₉	L ₁₀	L ₁₆
1FK7 High Dynamic with LP+ planetary gearbox, single-stage, type of construction IM B5, natural cooling, with connector, with/without brake															
36	1FK7033-7	LP070-MO1	70 (2.76)	52 (2.05)	16 (0.63)	62 (2.44)	M5	28 (1.10)	5 (0.20)	8 (0.31)	10 (0.39)	18 (0.71)	5 (0.20)	70 (2.76)	126 (4.96)
48	1FK7043-7 1FK7044-7	LP090-MO1	90 (3.54)	68 (2.68)	22 (0.87)	80 (3.15)	M6	36 (1.42)	5 (0.20)	10 (0.39)	12 (0.47)	25 (0.98)	6 (0.24)	90 (3.54)	158 (6.22)
63	1FK7061-7 1FK7064-7	LP120-MO1	120 (4.72)	90 (3.54)	32 (1.26)	108 (4.25)	M8	58 (2.28)	6 (0.24)	12 (0.47)	16 (0.63)	35 (1.38)	10 (0.39)	120 (4.72)	210 (8.27)
80	1FK7085-7 1FK7086-7	LP155-MO1	155 (6.10)	120 (4.72)	40 (1.57)	140 (5.51)	M10	82 (3.23)	8 (0.31)	15 (0.59)	20 (0.79)	43 (1.69)	12 (0.47)	150 (5.91)	266 (10.47)

Shaft height	Type	DIN IEC	Encoder system:												l E	d D	a ₁ P
			Resolver				Incremental encoder				Absolute encoder						
			without brake		with brake		without brake		with brake		without brake		with brake				
k LB	K -	k LB	K -	k LB	K -	k LB	K -	k LB	K -	k LB	K -						
36	1FK7033-7		170 (6.69)	260 (10.24)	195 (7.68)	285 (11.22)	195 (7.68)	285 (11.22)	220 (8.66)	310 (12.20)	30 (1.18)	14 (0.55)	92 (3.62)				
48	1FK7043-7 1FK7044-7		191 (7.52)	303 (11.93)	220 (8.66)	332 (13.07)	212 (8.35)	324 (12.76)	240 (9.45)	352 (13.86)	40 (1.57)	19 (0.75)	120 (4.72)				
63	1FK7061-7 1FK7064-7		185 (7.28)	325 (12.80)	228 (8.98)	368 (14.49)	208 (8.19)	348 (13.70)	251 (9.88)	391 (15.39)	50 (1.97)	24 (0.94)	155 (6.10)				
80	1FK7085-7 1FK7086-7		261 (10.28)	430 (16.93)	304 (11.97)	473 (18.62)	284 (11.18)	453 (17.83)	326 (12.83)	495 (19.49)	58 (2.28)	32 (1.26)	186 (7.32)				

1FK7033-7
1FK704-7
1FK706-7
1FK708-7

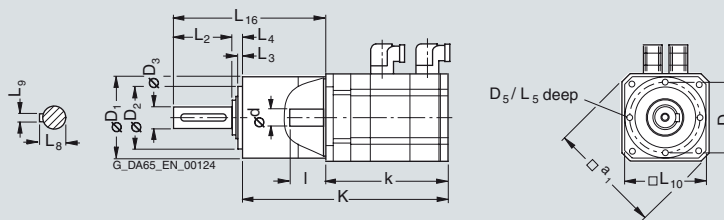

1FK7-DYA motors with/without DRIVE-CLiQ with planetary gearbox, single-stage

Dimensional drawings

For motor		Dimensions in mm (inches)																	
Shaft height	Type	Planetary gearbox																	
			D1	D2	D3	D4	D5	D7	D8	L1	L2	L3	L4	L5	L8	L9	L10	L12	
1FK7-DYA with planetary gearbox, single-stage, type of construction IM B5, natural cooling, with connector, with/without brake																			
36	1FK7032-5	DYA70-10	70 (2.76)	52 (2.05)	16 (0.63)	62 (2.44)	M5	82 (3.23)	5.5 (0.22)	56 (2.20)	28 (1.10)	5 (0.20)	8 (0.31)	10 (0.39)	18 (0.71)	5 (0.20)	20 (0.79)	76 (2.99)	
	1FK7034-5	DYA70-5																	
48	1FK7040-5	DYA90-10	90 (3.54)	68 (2.68)	22 (0.87)	80 (3.15)	M6	105 (4.13)	7 (0.28)	66 (2.60)	36 (1.42)	5 (0.20)	10 (0.39)	12 (0.47)	24.5 (0.96)	6 (0.24)	20 (0.79)	101 (3.98)	
	1FK7042-5	DYA90-5																	
63	1FK7060-5	DYA120-10	120 (4.72)	90 (3.54)	32 (1.26)	108 (4.25)	M8	140 (5.51)	9 (0.35)	95 (3.74)	58 (2.28)	6 (0.24)	12 (0.47)	16 (0.63)	35 (1.38)	10 (0.39)	25 (0.98)	128 (5.04)	
	1FK7063-5	DYA120-5																	
80	1FK7080-5	DYA155-10	155 (6.10)	120 (4.72)	40 (1.57)	140 (5.51)	M10	170 (6.69)	11 (0.43)	127 (5.00)	82 (3.23)	8 (0.31)	15 (0.59)	20 (0.79)	43 (1.69)	12 (0.47)	30 (1.18)	161 (6.34)	
	1FK7083-5	DYA155-5																	

Shaft height	Type	Encoder system:				Incremental encoder				Absolute encoder		AM2048S/R / AM22DQ	
		Resolver		Absolute encoder		Absolute encoder		IC2048S/R / IC22DQ		without brake		with brake	
		K	K1	K	K1	K	K1	K	K1	K	K1	K	K1
36	1FK7032-5	197 (7.76)	177 (6.97)	222 (8.74)	202 (7.95)	222 (8.74)	202 (7.95)	247 (9.72)	227 (8.94)	222 (8.74)	202 (7.95)	247 (9.72)	227 (8.94)
	1FK7034-5	222 (8.74)	202 (7.95)	247 (9.72)	227 (8.94)	247 (9.72)	227 (8.94)	272 (10.71)	252 (9.92)	247 (9.72)	227 (8.94)	272 (10.71)	252 (9.92)
48	1FK7040-5	194 (7.64)	174 (6.85)	223 (8.78)	203 (7.99)	214 (8.43)	194 (7.64)	243 (9.57)	223 (8.78)	223 (8.78)	203 (7.99)	252 (9.92)	232 (9.13)
	1FK7042-5	221 (8.70)	201 (7.91)	250 (9.84)	230 (9.06)	242 (9.53)	222 (8.74)	271 (10.67)	251 (9.88)	250 (9.84)	230 (9.06)	279 (10.98)	259 (10.20)
63	1FK7060-5	233 (9.17)	208 (8.19)	261 (10.28)	236 (9.29)	256 (10.08)	231 (9.09)	284 (11.18)	259 (10.20)	264 (10.39)	239 (9.41)	292 (11.50)	267 (10.51)
	1FK7063-5	278 (10.94)	253 (9.96)	306 (12.05)	281 (11.06)	301 (11.85)	276 (10.87)	329 (12.95)	304 (11.97)	309 (12.17)	284 (11.18)	337 (13.27)	312 (12.28)
80	1FK7080-5	250 (9.84)	220 (8.66)	278 (10.94)	248 (9.76)	273 (10.75)	243 (9.57)	300 (11.81)	270 (10.63)	281 (11.06)	251 (9.88)	309 (12.17)	279 (10.98)
	1FK7083-5	288 (11.34)	258 (10.16)	339 (13.35)	309 (12.17)	311 (12.24)	281 (11.06)	362 (14.25)	332 (13.07)	319 (12.56)	289 (11.38)	370 (14.57)	340 (13.39)

1FK703.-5
1FK704.-5
1FK706.-5
1FK708.-5

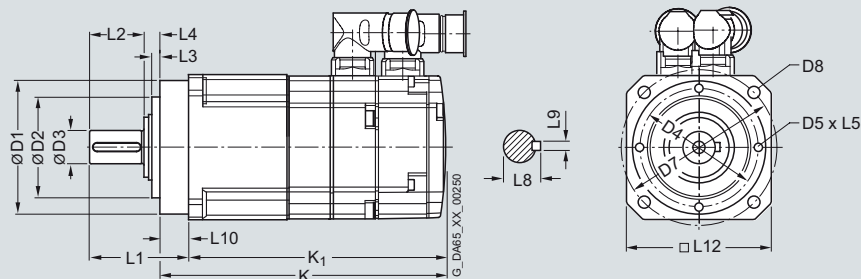

Servomotors

Notes

4