

MAC AC Servo Motors

Project Planning Manual

DOK-MOTOR*-MAC*****-PRJ1-EN-P



Title	MAC AC Servo Motors
Type of Documentation	Project Planning
Document number	209-0040-4356-00
Internal file reference	Mappe 5
Replaces	9.552.136.4-03 9.552.137.4-03 9.552.138.4-03 9.552.140.4-03 9.552.141.4-04 9.552.143.4-02
The purpose of this documentation?	This project planning documentation <ul style="list-style-type: none">• lists the technical data and power features of the motor• offers guidelines on the mechanical integration of the motor into the machine• offers guidelines on the electrical integration of the motor into the machine• outlines the available options• lists the order information for motor and its electrical connecting accessories• offers guidelines on the transport, handling and storage of motors.
Copyright	© INDRAMAT GmbH, 1996 Copying this document, and giving it to others and the use or communication of the contents thereof without express authority, are forbidden. Offenders are liable for the payment of damages. All rights are reserved in the event of the grant of a patent or the registration of a utility model or design (DIN 34-1).
Published by	INDRAMAT GmbH, Dept. ENA
Validity	All rights are reserved with respect to the content of this documentation and the availability of the product.

Table of Contents

Page

1. MAC AC Servo Motors	7
<hr/>	
2. Technical Explanations	12
<hr/>	
2.1. Ambient Conditions	12
2.2. Mechanical Features	15
2.3. Electrical Features	22
2.4. Motor Feedback	25
2.4.1. Tachofeedback	25
2.4.2. Tachofeedback and Second Shaft End	26
2.4.3. Tachofeedback with Mounted Encoder	27
2.4.4. Incremental Encoder	28
2.4.5. Absolute Encoder	34
2.5. Torque-Speed Characteristics	39
3. MAC 063	42
<hr/>	
3.1. Technical Data	42
3.2. Torque-Speed Characteristics	44
3.3. Shaft Load Capacity	47
3.4. Dimensional Data - Natural Convection	48
3.5. Dimensional Data - Radial Cooling	51
3.6. Dimensional Data - Axial Cooling	54
3.7. Available Options	56
3.8. Special Options	57
4. MAC 071	59
<hr/>	
4.1. Technical Data	59
4.2. Torque-Speed Characteristics	61
4.3. Shaft Load Capacity	67
4.4. Dimensional Data - Natural Convection	68
4.5. Dimensional Data - Radial Cooling	71
4.6. Dimensional Data - Axial Cooling	74
4.7. Available Options	77
4.8. Special Options	78
5. MAC 090	80
<hr/>	
5.1. Technical Data	80

5.2.	Torque-Speed Characteristics	82
5.3.	Shaft Load Capacity	85
5.4.	Dimensional Data - Natural Convection	86
5.5.	Dimensional Data - Radial Cooling	89
5.6.	Dimensional Data - Axial Cooling	92
5.7.	Available Options	95
5.8.	Special Options	96
6.	MAC 093	97
6.1.	Technical Data	97
6.2.	Torque-Speed Characteristics	99
6.3.	Shaft load Capacity	105
6.4.	Dimensional Data - Natural convection	106
6.5.	Dimensional Data - Radial Cooling	109
6.6.	Dimensional Data - Axial Cooling	112
6.7.	Available Options	115
6.8.	Special Options	116
7.	MAC 112	118
7.1.	Technical Data	118
7.2.	Torque-Speed Characteristics	120
7.3.	Shaft load Capacity	125
7.4.	Dimensional Data - Natural convection	126
7.5.	Dimensional Data - Radial Cooling	129
7.6.	Dimensional Data - Axial Cooling	132
7.7.	Available Options	135
7.8.	Special Options	136
8.	MAC 115	137
8.1.	Technical Data	137
8.2.	Torque-Speed Characteristics	139
8.3.	Shaft load Capacity	143
8.4.	Dimensional Data - Natural convection	144
8.5.	Dimensional Data - Radial Cooling	147
8.6.	Dimensional Data - Axial Cooling	150
8.7.	Available Options	153
8.8.	Special Options	154

9.	Electrical Power Connection	155
9.1.	Terminal Diagram	155
9.2.	Connector to Cable Allocations	156
9.3.	Power Connector (Motor Power Connector)	162
9.4.	Motor Power Cable	163
9.4.1.	Technical Data	163
9.4.2.	General Data	163
9.4.3.	Ready-made Motor Power Cables	164
9.4.4.	Order guidelines	169
10.	Electrical Connection Tachofeedback	170
10.1.	Terminal Diagram	170
10.2.	Tachofeedback Connector	170
10.3.	Tachofeedback Cable	171
10.3.1.	Technical Data	171
10.3.2.	Ready-Made Tachofeedback Cable	172
10.3.3.	Order guidelines	172
11.	Electrical Connection Incremental Encoder	173
11.1.	Terminal Diagram	173
11.2.	Incremental Encoder Connector	174
11.3.	Incremental Encoder Cable	174
11.3.1.	Technical Data	174
11.3.2.	Ready-Made Incremental Encoder Cable for Encoders with Square-Wave Pulses	175
11.3.3.	Order guidelines	175
12.	Electrical Connection Absolute Encoder	176
12.1.	Terminal Diagram	176
12.2.	Absolute Encoder Connector	176
12.3.	Absolute Encoder Cable	177
12.3.1.	Technical Data	177
12.3.2.	Ready-Made Absolute Encoder Cables	178
12.3.3.	Order guidelines	178
13.	Guidelines on Cable Routing	179
14.	Condition at Delivery	180
15.	Identifying the Merchandise	181

16. Storage, Transport and Handling	183
17. Mounting and Installation Guidelines	186
18. Service Notes	187
18.1. Contacting Customer Service	187
18.2. Repair Card	188

1. MAC AC Servo Motors

Applications AC servo motors of the MAC series are rapid-response servo drives in conjunction with TDM, KDS and DSC drive controllers. They are especially well-suited for use in:

- machine tools,
- textile machines,
- printing presses,
- packaging machinery,
- robotics,
- handling equipment and
- transfer facilities.

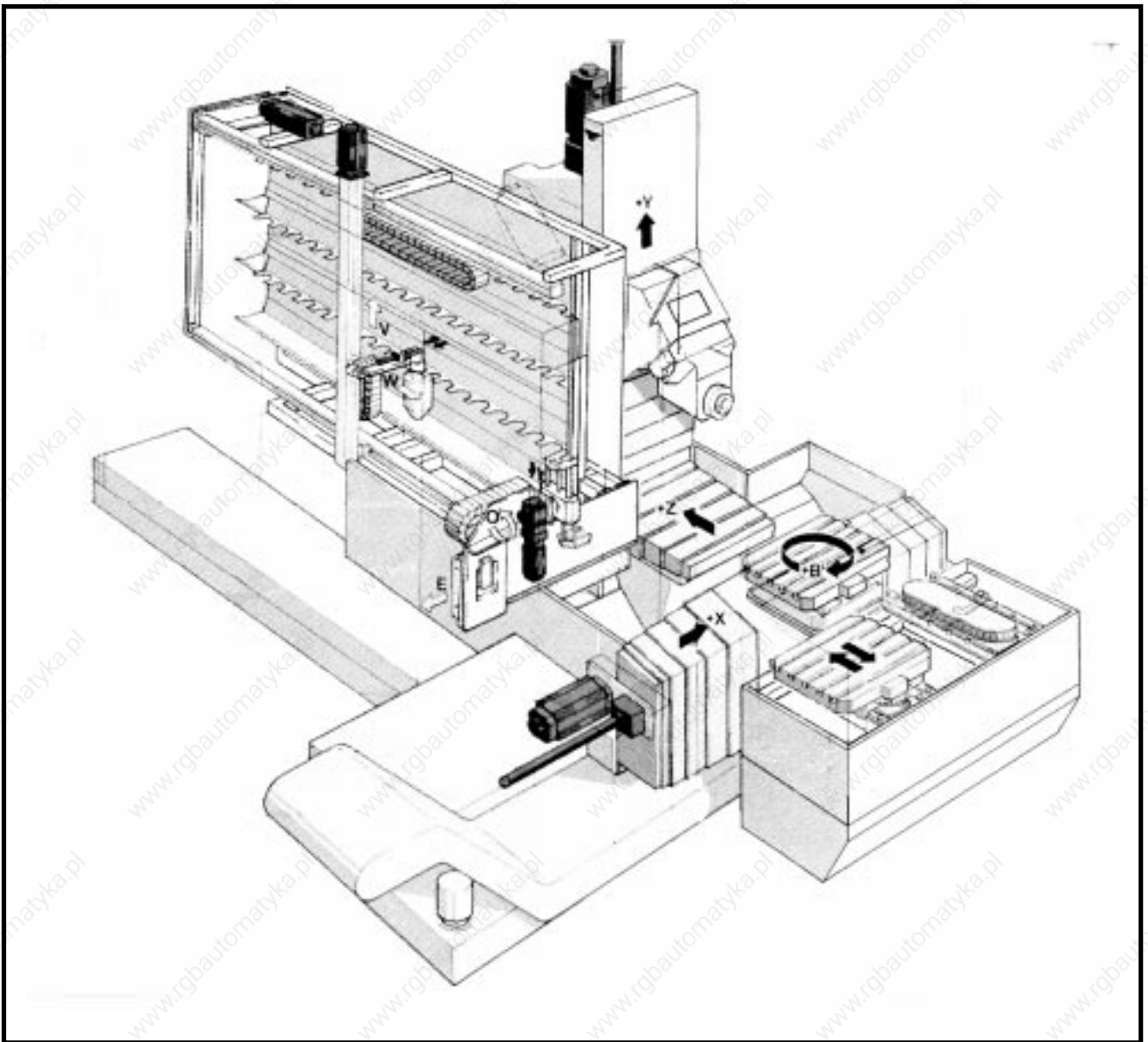

Fig 1.1: Applications example: a machining center with four axes with tool and workpiece handling facilities

Overview of power ratings

Figure 1.2 illustrates the available motor line with the power features, "continuous torque at standstill M_{dN} " and "nominal speed n ".

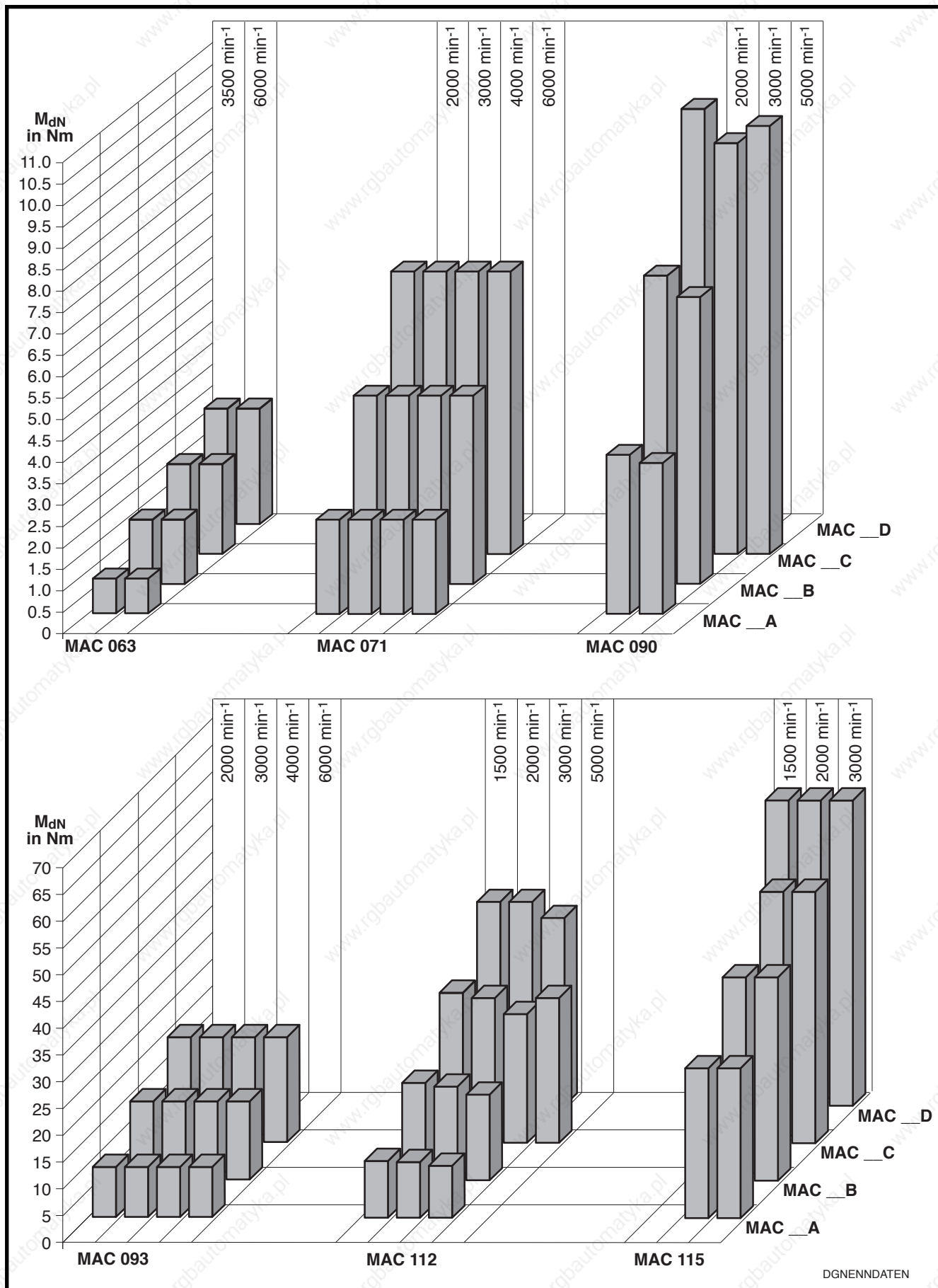

Fig 1.2: Power ratings

Construction and components of the motor

MAC AC servo motors are permanent magnet-excited motors with electronic commutation. The permanent magnets of the rotor are made up of materials which make it possible to construct motors with very low inertia.

Figure 1.3 illustrates the basic construction and components of a MAC AC servo motor.

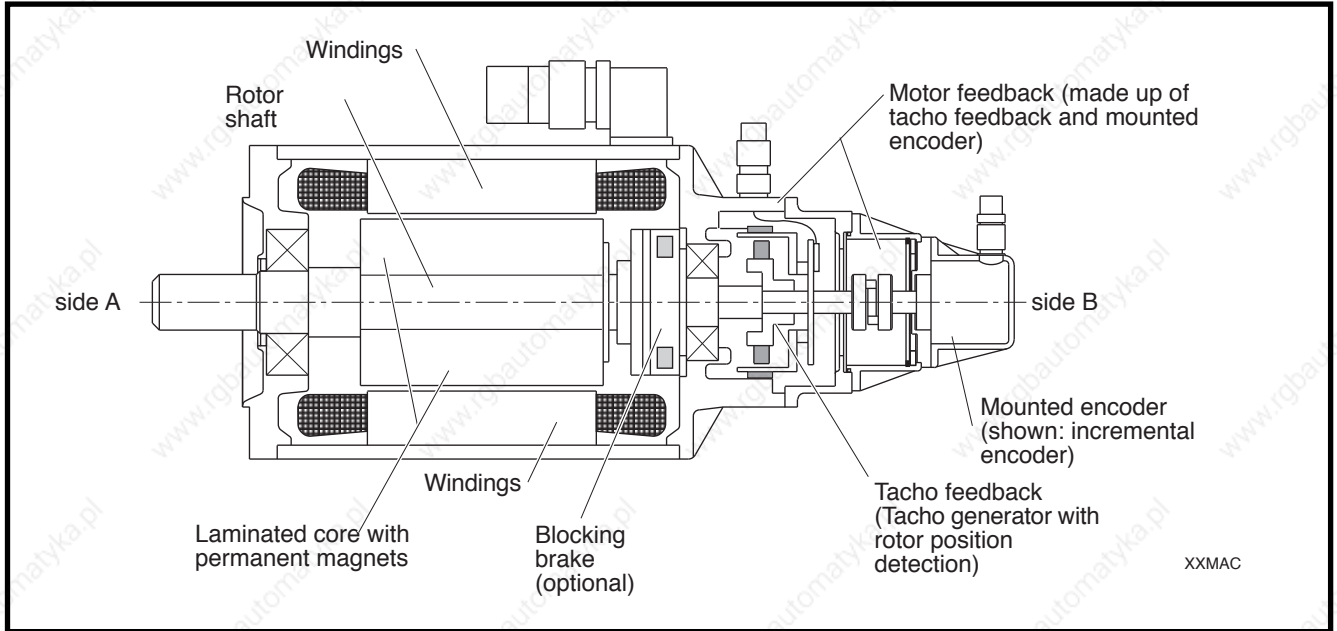

Fig 1.3: The structure of a MAC AC servo motor

Motor feedback

The motor feedback of a MAC AC servo motor is always made up of one tachofeedback. The motor can also be additionally equipped with a mounted encoder for position evaluation.

Tachofeedback

For speed evaluation per tacho-generator and rotor position recognition, the motors are equipped with a tachofeedback especially developed for this series. It is always integrated into the motor.

Mounted encoder

For position evaluation on the motor, the motor can also be equipped with:

- a second shaft end to mount the customer's own encoders,
- an incremental encoder and
- an absolute encoder.

- Operating reliability MAC motors achieve a **high degree of reliability** as a result of the following structural features:
- Maintenance-free operation due to:
 - the brushless design of the motor and
 - the use of life-time lubricated bearings.
 - Can be used directly within the working area of the machine even under poor environmental conditions such as affects of coolants, soluble oil emulsions and so on:
 - because the motor housing is totally enclosed as per protection category IP 65
 - because the motor power and tachofeedback cables as well as the encoder cables are designed to meet IP 65 demands.
 - Motor temperature is monitored with thermo switches integrated into the motor windings and stator housing. This prevents overload damage.
- Output data The **output data of the motor is high**. This is described in detail as follows:
- High dynamic performance due to favorable torque-inertia ratio.
 - A high overload capacity of the motor as the heat is dissipated from the stator windings to the outside wall of the motor housing.
 - Utilization of peak torque over a wide speed range.
 - High power to weight ratio due to compact construction.
 - High cyclic load capacity permits continuous start-stop operations with high repetition rates due to electronic commutation of the motor.
 - Excellent smooth running qualities resulting from the special design of the stator and high-resolution tachofeedback.
- Installation on the machine **Mounting** the motor to the machine **is simple**.
- Pinions and belt pulleys can be directly mounted onto the shaft because the design of the bearing assembly makes the application of high radial loads possible.
 - There is a defined assimilation of outside forces at the motor shaft. This means that the floating bearing of side A of the motor absorbs the radial forces. Side B absorbs the axial forces.
 - Thermal deformations affect side A.
 - The motor can be mounted in any orientation.
 - Flange design with throughholes in the flange makes it possible to mount as per design IM B5 or with windings in the flange as per design IM B14.
 - A variety of ready-made cables is available, eliminating additional installation work.
- Cooling The MAC AC servo motors are available with surface cooling for extreme loads. An overview of the blower options for the individual series is offered in Section 2.2, Figure 2.11.

- Holding brake** MAC motors can be delivered with or without holding brakes.
 The holding brake makes it possible to clamp (hold into place) the output shaft at standstill. This achieves a safe standstill of the axis even when power is off.
- Output shaft** The output shaft is available in two different designs:
- as a plain shaft for non-positive shaft-hub connections and
 - shafts with keyways for form-fitting shaft-hub connections.
- Smooth run** The MAC 090 and 112 AC servo motors are available with a special windings design which achieves a high degree of smooth run. It is particularly well-suited for use in grinding machines and precision lathes.
 It must be designated in type code field 5 with a "G". In this case, the tacho design with increased smooth run should be used as motor feedback (type code field 6 with an "F").
- Electrical connections** The power, tachofeedback and encoder cables are directly connected to the motor with the use of connectors on the corresponding flanged sockets.
- Labelling the sides** To make sure that the sides of the MAC are clearly labelled and that there is no confusion, they have been fixed and illustrated in the figure below.

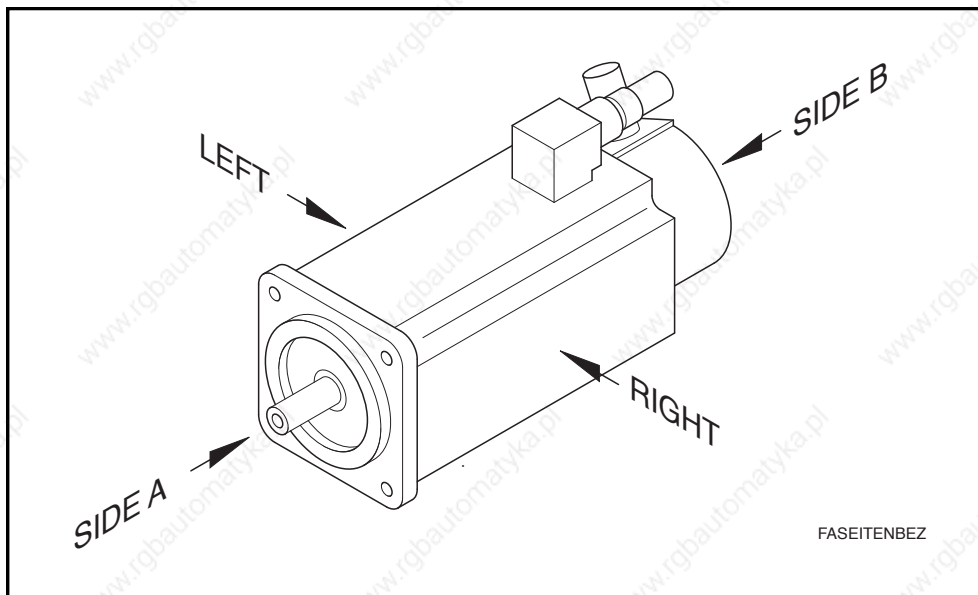

Fig 1.4: Labelling the sides of the MAC servo motor

2. Technical Data

This section outlines a description of the ambient conditions, the mechanical and electrical features of the motor as well as the motor feedback. Section 2.5 offers important details about the torque-speed characteristics which are, in turn, depicted for each motor type in sections 3.2, 4.2 through 8.2.

2.1. Ambient Conditions

Installation elevation
and ambient
temperatures

The output data outlined in the section "Technical Data" are achieved under the following conditions:

Ambient temperature: 0 ... + 45 °C

Installation elevation: 0 ... 1000 meters above sea level

If the conditions deviate from the values, then the output data will decrease as depicted in the diagrams of Figure 2.1. If higher ambient temperatures and higher installation elevations occur simultaneously, then the load factors f_T and f_H must be multiplied.

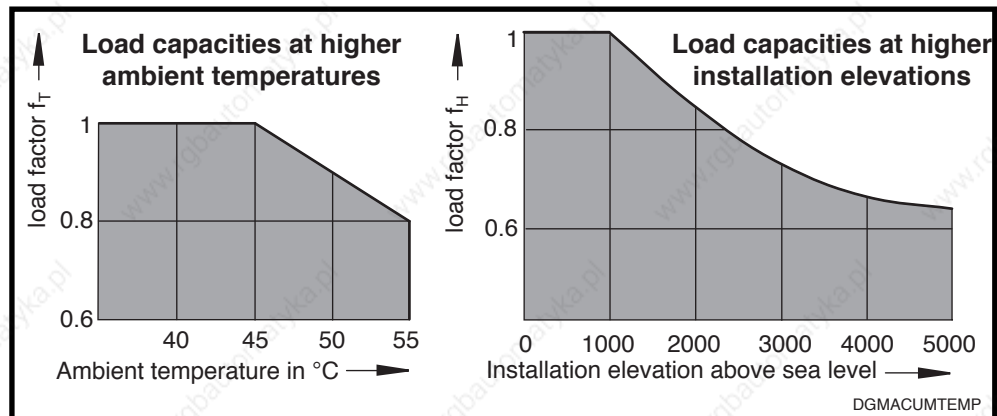

Fig 2.1: Load capacities at higher ambient temperatures and higher installation elevations

Protection category

The MAC motors are protected by their housing and covers which in construction and design adhere to the guidelines found in DIN 40 050 and are, therefore, protected against:

- contact with motor parts either moving or alive (contact guards),
- penetration by extrinsic objects and
- penetration of water.

The protection categories are laid down by the abbreviation IP (International Protection) and two numbers for the type of protection, e.g., IP 65.

The first number represents the degree of protection afforded against contact and penetration by extrinsic objects (see Figure 2.2). The second number represents the degree of protection afforded against the damaging penetration by water (see Figure 2.3).

Figure 2.4 depicts the range of the protection categories as applicable to MAC motors.

First digit	Protection against contact and extrinsic objects
0	Little or no protection.
1	Protection against penetration by extrinsic objects with a diameter exceeding 50 mm. No protection against direct access, e.g., by a hand. Will keep larger body surfaces out, however.
2	Protection against penetration by extrinsic objects with a diameter exceeding 12 mm. Will keep fingers or similar objects out.
3	Protection against penetration by extrinsic objects with a diameter exceeding 2.5 mm. Keeps out tools, wiring or similar objects thicker than 2.5 mm.
4	Protection against penetration by extrinsic objects with a diameter exceeding 1 mm. Keeps out tools, wiring or similar objects thicker than 1 mm.
5	Protection against damaging dust. Complete penetration by dust is not prevented, but the dust may not be permitted to penetrate to the extent that the operation of the electrical equipment is in any way hindered (protected against dust). Complete protection against penetration by extrinsic objects.
6	Protection against the penetration of dust (dust-free). Complete protection against penetration by extrinsic objects.

Fig 2.2: Protection grades - contact and penetration per DIN 40050, sec. 2 (6/72 edition)

Second digit	Protection against Water
0	Little or not protection.
1	Protection against vertically dripping water (dripping or trickling water). It may not have any destructive affects.
2	Protection against vertically dripping water. It may not have any adverse affects on electrical equipment tilted up to 15° in contrast to its normal position (water dripping or trickling at an angle).
3	Protection against water falling at an angle of up to 60°. Does not permit any damaging affects (sprayed water).
4	Protection against water sprayed at the equipment (housing) from all directions. Does not permit any damaging affects (splashwater).
5	Protection against a jet of water sprayed from a nozzle onto the equipment (housing) from all directions. Does not permit any damaging affects (jet of water).

Fig 2.3: Protection grades for water per DIN 40050, sec. 2 (6/72 edition)

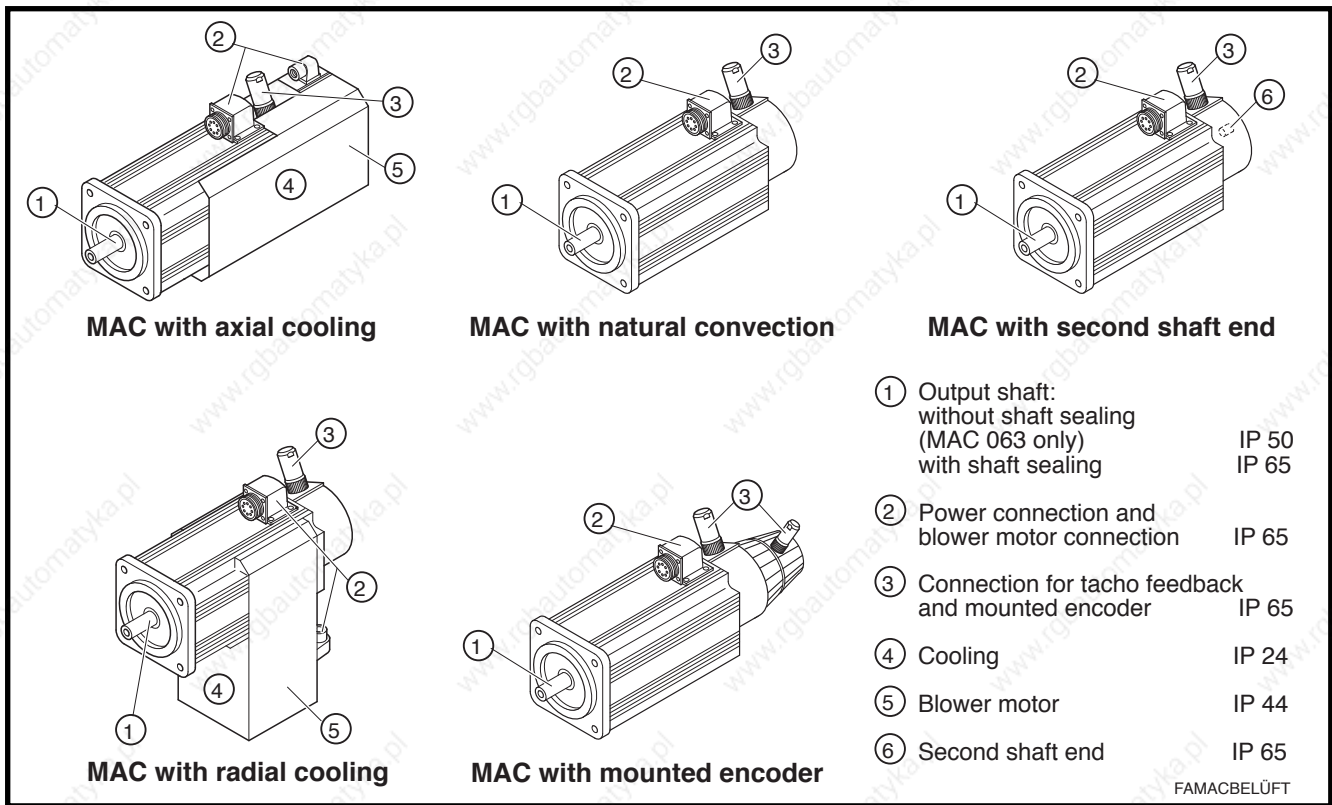

Fig 2.4: Range of protection categories of MAC motors

Ambient mechanical conditions

MAC servo motors can be operated in a stationary manner under weather-proofed conditions as per IEC 721-3-3, the 1987 edition, or EN 60721-3-3 the 6/94 edition:

- as per class 3M1 respective the longitudinal axis of the motor and
- as per class 3M6 respective the lateral axis of the motor.

The maximum values stated in Figure 2.5 thus apply to transportation and operation of MAC servo motors.

Environmental variables		Unit	Maximum values longitudinal axis	Maximum values lateral axis
sinusoidal oscillations	excursion amplitude	mm	0.3	7.0
	frequency range	Hz	2 to 9	2 to 9
	acceleration amplitude	m/s ²	1	20
	frequency range	Hz	9 to 200	9 to 200
shocks	total shock-response spectrum	-	Type L per IEC 721-1 edition of 1990, table 1 section 6	Type II per IEC 721-1 edition of 1990, table 1 section 6
	reference acceleration (in IEC 721-1 peak acceleration)	m/s ²	40	250
	duration	ms	22	6

Fig 2.5: Maximum values of the environmental variables



MAC servo motors are only suited for such extreme demands as is the case with punching, pressing, press feeds and similar applications, if shock-damped mounted or mounted shock decoupled.

We cannot recommend a generally applicable solution for shock-damped mounting. It is dependent on the respective construction of the machine and the results of metrological tests.

A shock-damped variant for incremental encoders is available for the MAC AC servo motors. This has been tested for punching, pressing and press feed applications.

Housing coat The housing of the MAC motors is painted with a black prime coat. An additional layer of paint can cover this prime coat. The thickness of the layer may, however, not exceed 40 µm.

This prime coat is resistant to:

- weathering, yellowing and chalky build-ups as well as
- diluted acids and lyes

The coat can, however, peel if the housing is frequently cleaned with a steam cleaner.

2.2. Mechanical Features

Construction and mounting orientation The mounting flange is designed, in all types of motors, in such a way that mounting as per design B5, i.e., mounting with flange with throughholes, is possible.

Mounting mode as per design B14, i.e., mounting flange with windings, is **additionally** possible in the following motors:

- MAC 090
- MAC 093
- MAC 112
- MAC 115

Figure 2.6 demonstrates the ways that the motors can be mounted to the machine as per DIN 42950, section 1, the 8/77 edition.







Construction	Permissible mounting orientations per DIN IEC 34-7		
B05	 IM B5	 IM V1	 IM V3
B14	 IM B14	 IM V18	 IM V19

Fig 2.6: Permissible mounting orientations



In those cases where the motors are mounted in orientations IM V3 and IM V19, it is necessary to prevent liquids from collecting at the output shaft over extended periods of time. Even the use of a shaft sealing does not absolutely prevent liquids from penetrating, along the output shaft, into the housing of the motor.

Pilot diameter To generate compatibility with the motors of other manufacturers, it is possible to also select a mounting flange with a customized pilot diameter in addition to the standard types. This is possible only with some of the motors. The choices and appropriate dimensions are listed in the table in Figure 2.8.

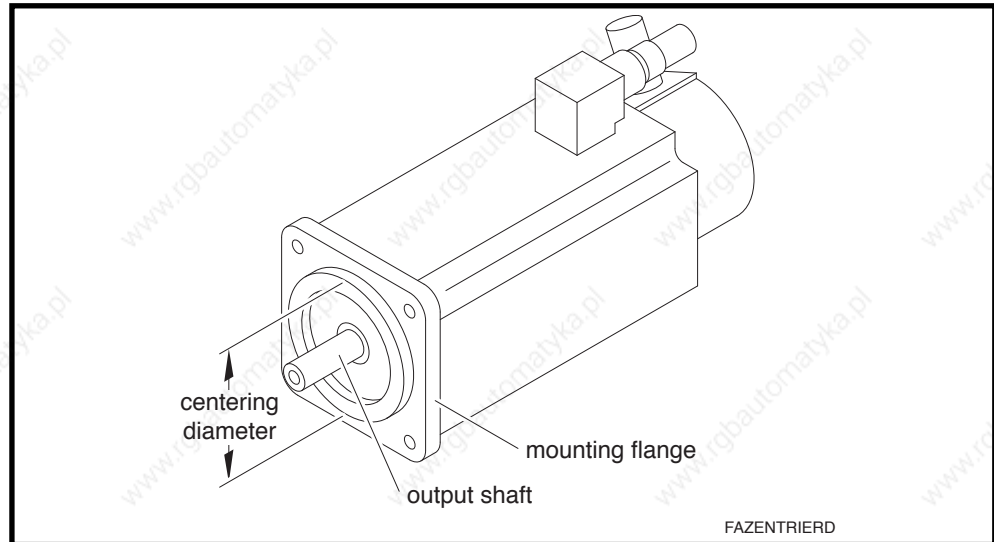

Fig 2.7: Defining the term centering / pilot diameter

Motor Series	Pilot diameter in mm	
	Standard types	Customized types
MAC 063	95	—
MAC 071	95	—
MAC 090	110	130
MAC 093	110	130
MAC 112	130	180
MAC 115	130	180

Fig 2.8: Pilot diameters for the individual motor series

Output shaft The design of the output shaft can be selected by the user. INDRAMAT recommends the use of plain output shafts.

Plain output shaft

A backlash-free and non-positive transmission of torque can be achieved with a plain shaft. Clamping sets, pressure sleeves or similar clamping components can be used for coupling pinions, belt pulleys or similar elements.

Output shaft with keyway

The output shaft with keyway adheres to the requirements specified in DIN 6885, sheet 1, 8/68 edition. This achieves a form-fitting torque transmission. This type of shaft-hub connection is suitable for lesser demands. A multi-

axial stress state occurs at the shaft-hub connection as a result of torsion, bending, radial and axial loads. It is possible, during powerful reverse operations, for the bottom of the key to turn out and reduce the quality of concentricity. Ever-increasing deformations can cause fractures. The use of plain shaft ends with friction-locked connections is therefore recommended.

Shaft sealing The shaft sealing is attached to the flange. It ensures that no liquids can penetrate into the motor housing along the shaft. An output shaft with shaft sealing is required for those applications where dirt or the affects of a jet of water can be present. The protection category in this case is IP 65.

In the MAC 071, 090, 093, 112 and 115, the output shafts are always equipped with a shaft sealing.

In the MAC 063 line, the output shaft can be selected with or without the sealing. The output shaft of this line is generally not equipped with the ring. The protection category in this case is IP 50.

Permissible shaft load Load is applied to the shaft as soon as radial or axial forces affect the motor shaft.

The **permissible radial force** (radial shaft load) is depicted in a diagram in sections "Shaft Load Capacity", i.e., sections 3.3., 4.3 and so on.

The permissible radial force is depicted in terms of

- the average speed
- and the point of application of force.

The **permissible axial force** (axial shaft load) can be calculated with the aid of a formula. It can be found in this section.

Thermal deformations



Thermal deformations in length affect side A of the motor. This means that the A side of the motor shaft end can shift up to 0.6 mm with respect to the motor housing. As a result, there

- **is a shifting of position by using drive pinions with helical teeth mounted to the motor output shaft but not axially fixed to the machine or**
- **thermal stress is occurring by using drive pinions with helical teeth axially fixed to the machine with bevel gear pinions. The latter can lead to damage on side B of the motor.**

Cooling For extreme loads, as is, for example, the case with continuous start-stop operations with a high level of repetitive frequency, it is possible to mount a surface-cooling unit to some of the motors.

Blower motors, operating with 1 x AC 230 V and AC 115 V, are available.

Axial surface cooling

Axial cooling is suited for those applications that need a slender form.

Axial surface-cooling units are not available for motors with a second shaft end. What is available for each line of motor is listed in the table in Figure 2.11.

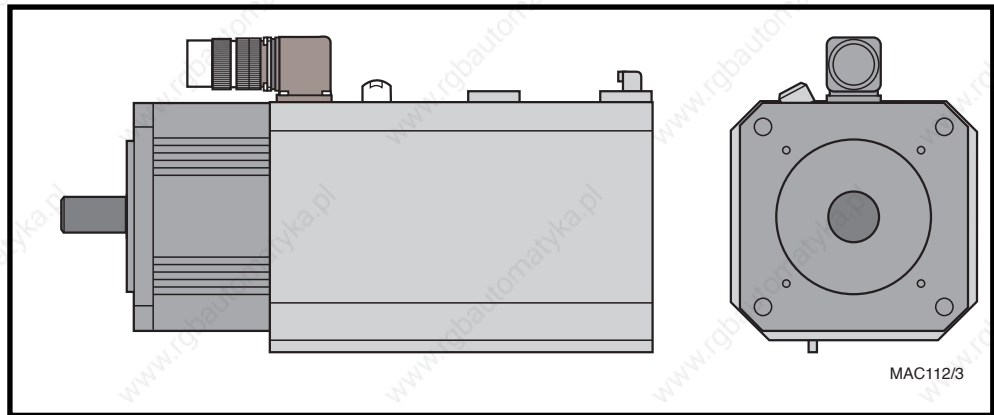

Fig 2.9: An example of a MAC servo motor with axial surface cooling

Radial surface cooling

Radial cooling is suited for those applications that need a short construction.

The use of radial surface-cooling units is recommended in those cases where shock loads are high.

If a radial surface-cooling unit is to be mounted on the motor, then the arrangement of the blower unit on the motor must be determined. The following possibilities are available with every line of motor (looking towards motor shaft):

- the blower is located under the motor shaft,
- the blower is to the left of the motor shaft or
- the blower is to the right of the motor shaft.

Radial surface cooling is not available for the MAC 063 motors with motor length A.

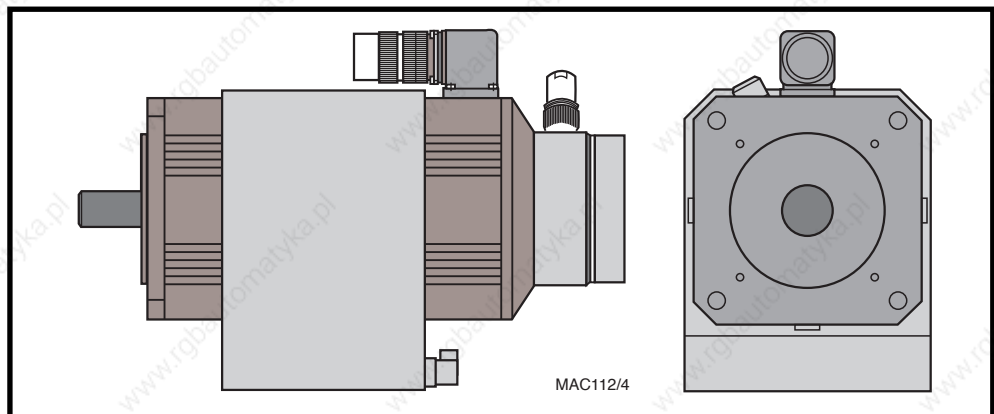

Fig 2.10: An example of a MAC servo motor with radial surface cooling with the blower under the motor shaft

The blower options for the individual motor series are listed in the table found in Figure 2.11.

Motor type	Blower for surface cooling	
	axial	radial
MAC 063	+ 2) 3)	+ 1)
MAC 071	+ 2)	+
MAC 090	+ 2)	+
MAC 093	+ 2)	+
MAC 112	+ 2)	+
MAC 115	+ 2)	+

+ available
 1) not available for motor length A
 2) not available for motors with tachofeedback and second shaft end
 3) not available for motors with tachofeedback and mounted encoder

Fig 2.11: Blower options

Holding brake For a backlash-free holding of the servo axes when the machine is powered off, it is possible to equip them with a holding brake.

The holding brake, especially developed for those motors, works along the closed-circuit principle. At zero current, a magnetic force acts on the brake armature disc. This means that the brake is locked and holding off the axis. With the application of 24 V DC, the electrical field cancels the permanent magnetic field and the brake opens.

The customer is responsible for the control of the holding brake with the use of either a PLC or a hardware switch. Various recommendations are outlined in the Applications Manual for "MAC Servo Drives with Servo Drive Modules TDM and KDS".



The holding brake alone cannot guarantee the safety of personnel as it can fail or wear down. Additional measures must be taken to ensure personnel safety. These must be undertaken by the manufacturer of the machine and can, for example, be the mounting of a second brake.



The holding brake is not a working brake. It can wear down after 20,000 motor revolutions against the closed brake.

If the motor has been stored for any extensive period of time, then the following guidelines should be noted before commissioning it:

If the motor is stored for a period exceeding two years, then it is necessary to grind it in before using it.

To grind it in:

1. Run the motor at a speed of approximately 100 speed.
2. Close the holding brake and keep it closed for approximately 60 seconds.

Note: Open the conductor of the holding brake to the PLC or the hardware circuitry.

3. Shut down the drive after 60 seconds.
4. Reconnect the holding brake to the PLC or the hardware circuitry.

The holding brake is available with the following holding torques for each respective motor series.

Holding torque	MAC ...					
	063	071	090	093	112	115
3 Nm	X	X				
6.5 Nm		X	X	X		
14 Nm			X	X	X	
22 Nm				X		
40 Nm					X ¹⁾	
45 Nm						X
60 Nm					X ¹⁾	X

¹⁾Not available for motor length A.

Fig 2.12: The holding torque of the holding brakes

Power connection

The user must order the output direction of the power connections in accordance with the conditions at the machine. The output direction cannot be altered after delivery.

The following variants are available (also see Figure 2.13):

- connector to side A
- connector to side B
- connector to the right
- connector to the left

Note: With the MAC 063s only the output directions towards side A or side B are available.

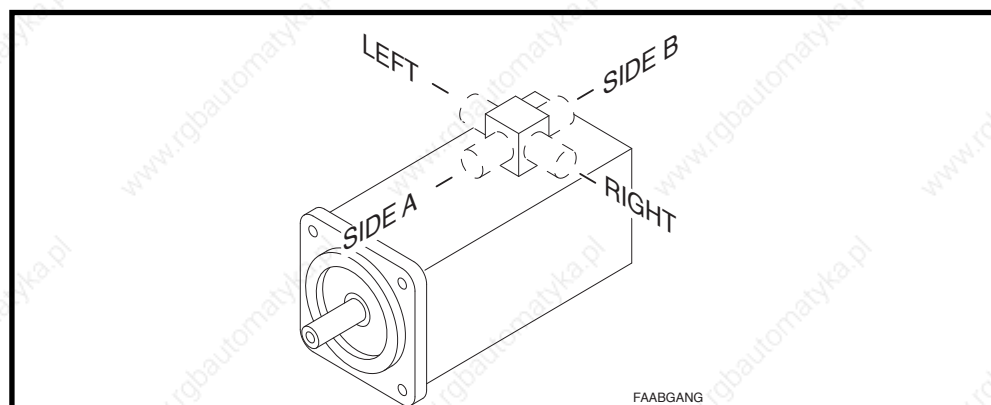

Fig 2.13: Possible output directions of the power connections

- Feedback connector Different types of connectors can be selected for connecting the motor feedback cable depending upon the installation conditions. Available are:
- straight connectors and
 - angle connectors.

Information about the allocation of connector type to motor type can be found in the dimensional data sheets and in section 13.2 "Connector for the Feedback".

Straight connector

Figure 2.14 depicts a motor with tachofeedback and straight encoder connector.

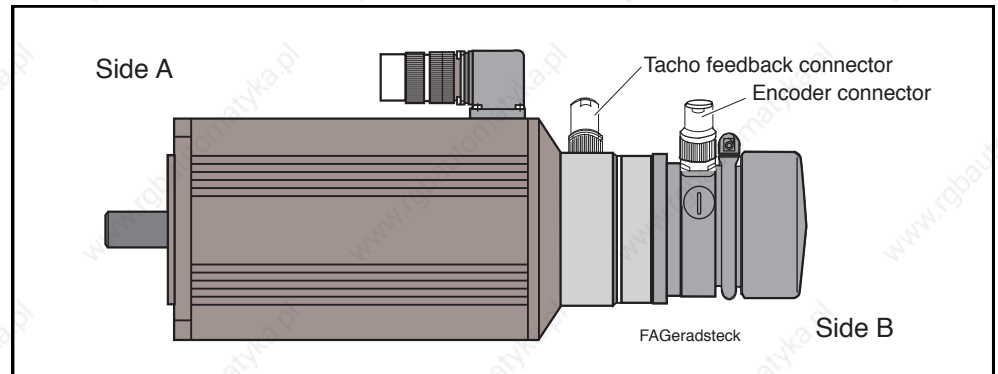

Fig 2.14: A MAC motor with straight tachofeedback and encoder connectors

Angle connector

INDRAMAT supplies and delivers the angle connectors so that the output direction of the cable, once inserted into the flanged socket, is side B of the motor.

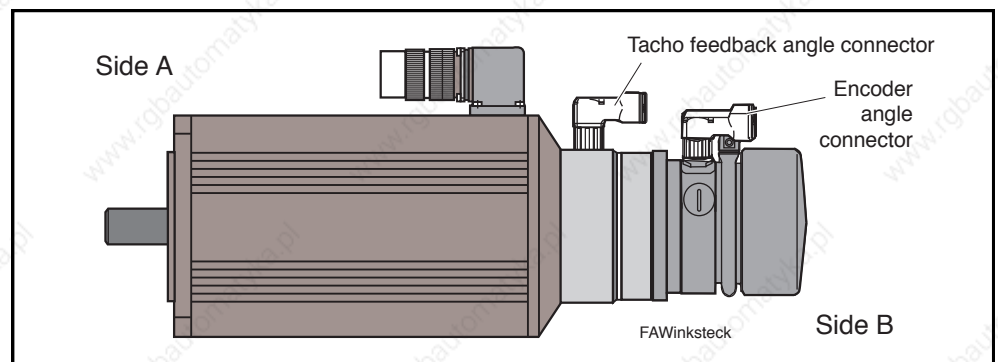

Fig 2.15: A MAC motor with angle connector (side B is output direction at delivery)

The user can change the output direction. Just release the four fixing screws (see Figure 2.16). The connector parts can now be turned in increments of 90° into the position desired.



Make sure that neither the gasket nor the cable cores of the cable are damaged when re-tightening the screws.

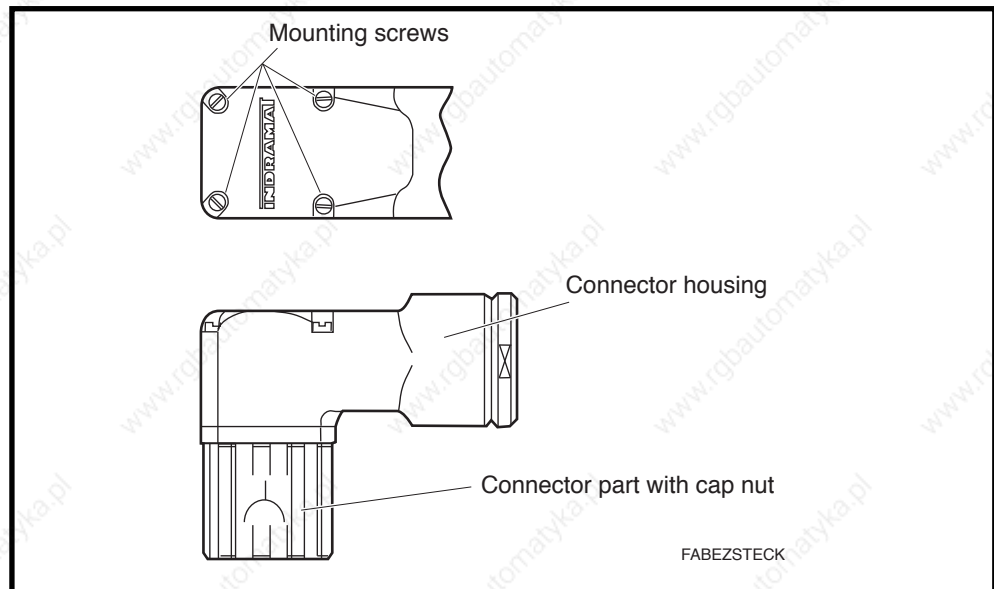

Fig 2.16: Labelling the parts of the connector



Angle connectors cannot be used in conjunction with an axial surface cooling unit.

2.3. Electrical Features

Terminal diagram

The terminal diagram shown in Figure 2.17 is purely schematic. It represents a checklist for all the necessary electrical connections to operate a MAC AC servo motor.

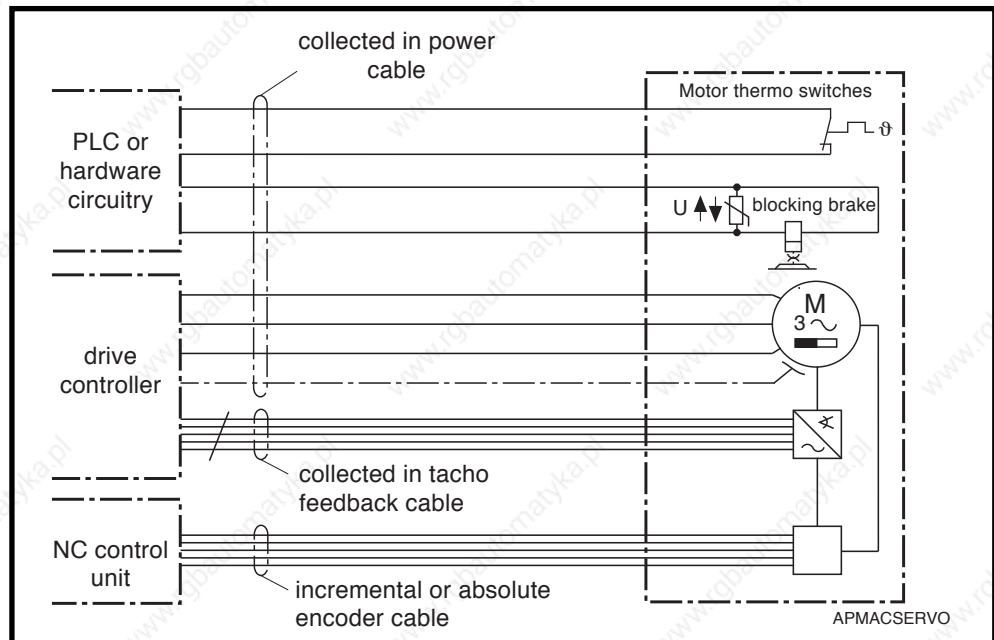

Fig 2.17: Schematic terminal diagram

The following electrical connections are on a MAC motor:

- Power connection (always present)
- Tachofeedback connection (always present)
- Incremental or absolute encoder connection (this depends on the type of motor implemented)

If a blower for surface cooling is mounted to the motor, then a motor blower connection is also there. This is not shown in the terminal diagram.

The electrical connections of INDRAMAT drives have been standardized to minimize cable diversity. Sections 12 and 13 specify the electrical connections for a given application and motor type.

Power connection The following connections are integrated into the power connection:

- power cable,
- connecting cable for the thermo switch(es)
- and the connecting cable for the holding brake.

There are thermo switches built into the windings of the motor and the stator housing. They are electrically connected in series and conducted together at the power connection out of the motor housing. The opening of the thermo switch must be detected either by a superordinate PLC or hardware circuitry, and then an appropriate error reaction generated as quickly as possible.

Motor power connectors for the electrical power connections are available for either:

- crimping or
- soldering.

Power cables with metrical diameters can be either crimped or soldered to the motor power connector. Power cables with inch diameters can only be soldered.

Feedback connection There is a 12-pin flanged socket on the motor for the feedback and encoder connections.

The connection diagram, available feedback cables and connectors are all outlined in section 10.

Motor blower connection The motor blower is integrated into the hardware circuitry as per customer requirements as, for example, via a protective motor switch which would then operate independently of the controller.

The connector cable must have three cores with a diameter of at least 0.75 mm².

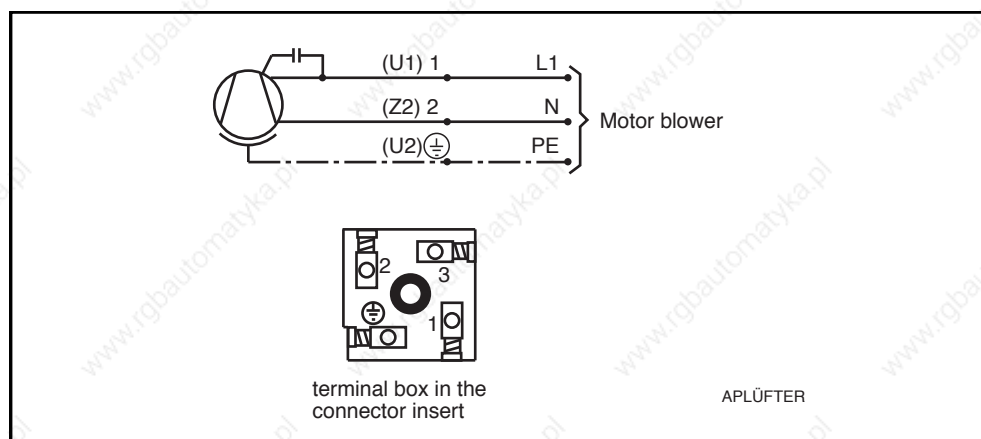

Fig 2.18: How to connect the blower

Connecting the cable to the motor blower

The following steps describe how to connect the cable to the motor blower. The individual parts of the connector are illustrated in Figure 2.19.

Procedure:



The cable may only be connected by either an electrician or trained personnel under the supervision of an electrician.

1. Release conduit thread screw (6) (SW 17).
2. Remove slotted screw (1) with screw driver (5) from flanged socket (4).
3. Remove connector housing (2) with connector insert (3) from flanged socket (4).
4. Pull out slotted screw (1).
5. Pull connector insert (3) out of connector housing (2) with screw driver (5) (see Figure 2.19).
6. Slide conduit thread screwed joint (6), ring (7), gasket (8) and connector housing (2) onto the cable (3x0.75 mm²).
7. Strip cable sheath at a length of approx. 20 mm, strip litz wire for approx. 10 mm. Now connect as per terminal diagram in Figure 2.18 to the terminal box in the connector insert (3).
8. Push connector insert (3) into connector housing (2), attach slotted screw (1) and screw connector onto flanged socket (4).
9. Remount conduit thread screwed joint (6) making sure strain relief is adequate!

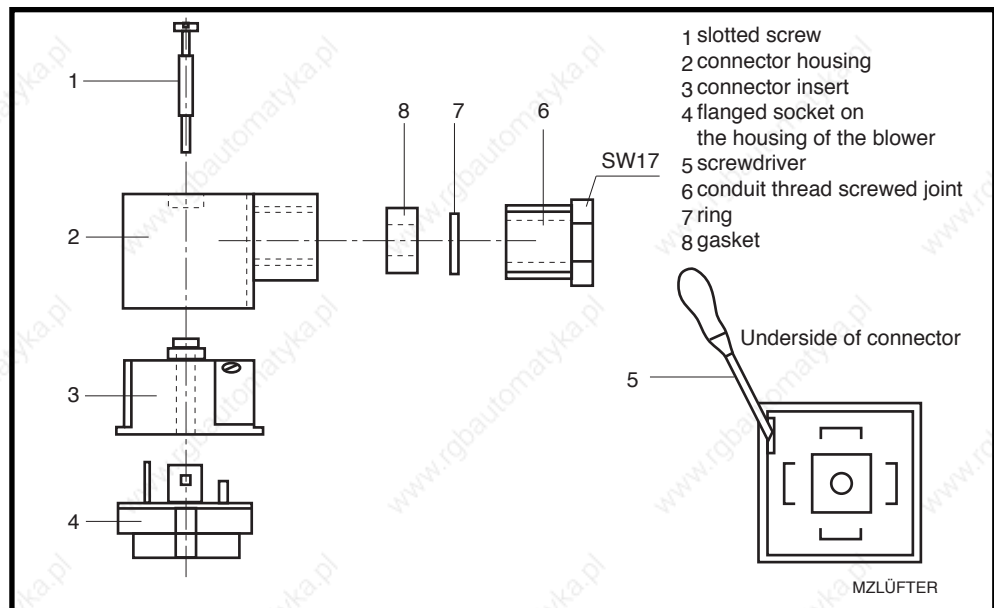

Fig 2.19: The parts of a blower connector

2.4. Motor Feedback

The motors are equipped with a motor feedback for the evaluation of position and speed and for the detection of rotor position. The motors are available in those versions illustrated in Figure 2.20.

Versions The motor feedback is always made up of a tachofeedback and can be additionally fitted with an encoder.

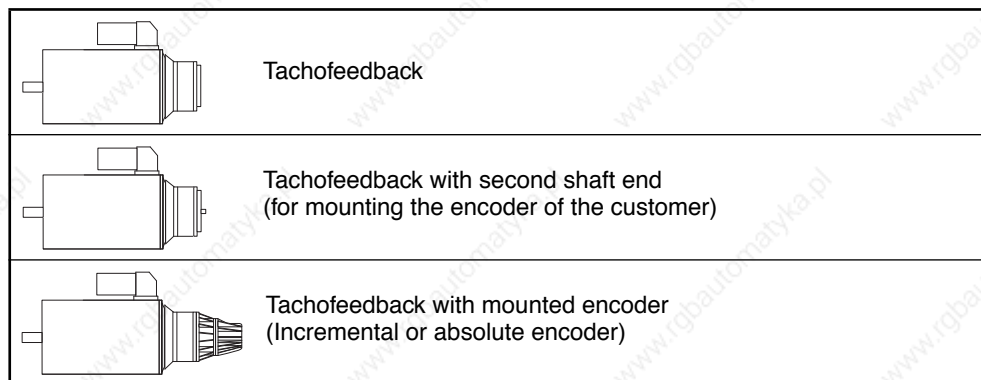

Fig 2.20: Available motor feedback versions

2.4.1. Tachofeedback

This design makes it possible to detect and evaluate both rotor position and velocity. The velocity feedback value is generated with residual ripple in some models and is suited for:

- either standard applications (tacho type „C“; see type code)
- applications with extreme high smooth run qualities (tacho type „F“; see type code)

The "Tachofeedback" version can be used in all machines in which there is, for example, a direct position evaluation via a linear scale or with applications with uniform rotations.

Tacho voltage can be selected to meet the following:

- to match nominal motor speed
With a nominal speed of $> 3000 \text{ min}^{-1}$ tacho voltage equals $1.5\text{V}/1000 \text{ min}^{-1}$.
With a nominal motor speed of $\leq 3000 \text{ min}^{-1}$ tacho voltage equals $3\text{V}/1000 \text{ min}^{-1}$.
- $1.5 \text{ V}/1000 \text{ min}^{-1}$ for speeds exceeding 3200 min^{-1} in motors with a maximum nominal speed of 3000 min^{-1}
- $6 \text{ V}/1000 \text{ min}^{-1}$ for applications making higher demands of the resistance to interference in tachofeedback lines or requiring smooth run qualities at a maximum nominal speed of 1600 min^{-1} .

The options for each line of motor have been compiled in Table 2.21.

Motor Series	Tacho version	Tacho Voltage		
		matches nominal motor speed	$\frac{1.5 \text{ V}}{1000 \text{ min}^{-1}}$	$\frac{6 \text{ V}}{1000 \text{ min}^{-1}}$
063	standard	X		
	higher smooth run quality	X		
071	standard	X	X	
	higher smooth run quality	X	X	
090	standard	X	X	
	higher smooth run quality	X	X	X
093	standard	X	X	
	higher smooth run quality	X	X	
112	standard	X	X	
	higher smooth run quality	X	X	X
115	standard	X	X	
	higher smooth run quality	X	X	

Fig 2.21: Optional tachofeedbacks and allocation to motor series

2.4.2. Tachofeedback and Second Shaft End

This version is identical to the version "Tachofeedback", expanded, however, with an accessible second shaft end on side B of the motor. Additional components, encoders in particular, can be mounted hereto.

The second shaft end has a protection category of IP 65, i.e., the component mounted does not need to be completely sealed.

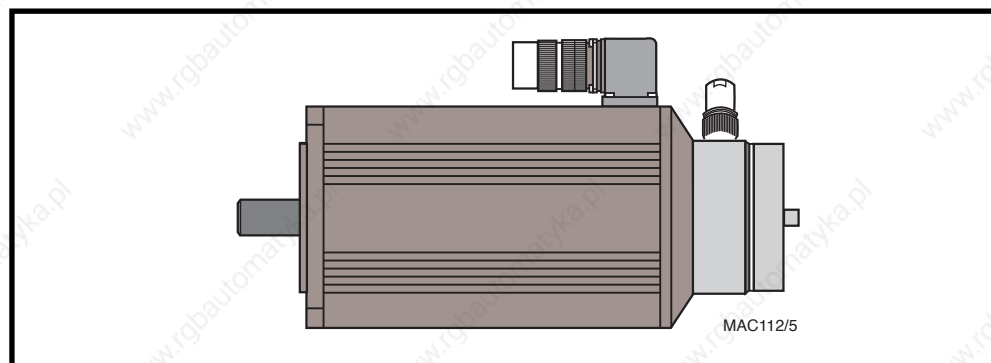

Fig 2.22: MAC servo motor with tachofeedback and a second shaft end

2.4.3. Tachofeedback with Mounted Encoder

This version corresponds to the "Tachofeedback" version with respect to the detection of velocity feedback value and rotor position. Mounted encoders in the following versions are available for position detection and evaluation:

- Standardly mounted incremental encoder for use with machines with lower shock loads.
- Incremental encoders with shock-damped mounting for use in presses, stamping machines and similar machinery
- and an absolute encoder

These mounted encoders have been especially designed for INDRAMAT motors and are extremely resistant to environmental conditions.

These are introduced in greater detail in sections 2.4.4. and 2.4.5.

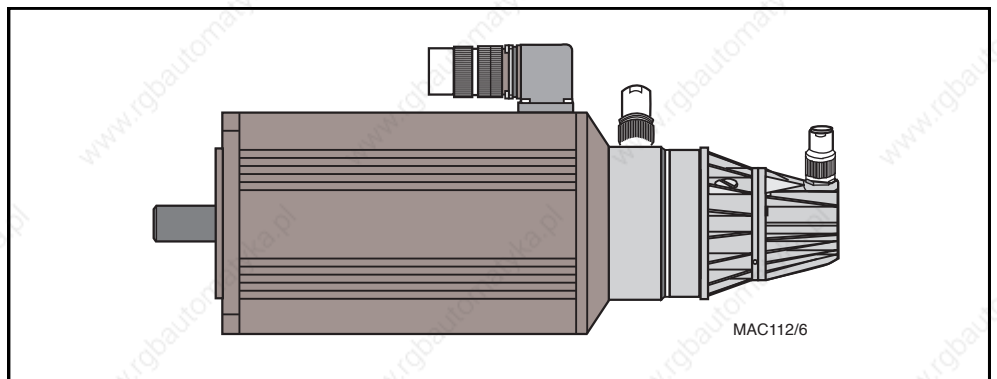

Fig 2.23: MAC servo motor tachofeedback with mounted encoder (ex: incremental encoder)

2.4.4. Incremental Encoders

Incremental encoders work with either square-wave pulses or sinusoidal signals. They are available to accommodate different supply voltages. The available versions are listed in Figure 2.24.

No. of pulses/ no. of lines	Pulse		
	Square-wave signal		Sinusoidal signal
	Supply voltage		Supply voltage
	5V	10 - 16V	5V
50	568LV		
125	542LV		
200	553LV		
250	515LV		527BX
400	516LV	634LX	
500	517LV		
600	572LV		
625	524LV		
900			593BX
1.000	518LV		647BX
1.024	519LV		
1.250	520LV	637LX	
1.500	538LV		
1.800	574LV		
2.000	521LV		
2.500	522LV		
3.600	594LV		
5.000	511LV		

Incremental encoders can only be mounted to MAC 063s with natural convection or radial surface-cooling units.

Fig 2.24: Incremental encoder options

Voltage source:	5 V, ± 5 %
Current consumption:	150 mA
Signal level:	U(high) ≥ 2.5 V; U(low) ≤ 0.5 V; at 20 mA
Load capacity:	20 mA at "high" and "low" signal
Total operating time:	rise and fall times ≤ 200 ns
Maximum sampling frequency:	300 kHz
Incremental encoder signal:	TTL - square wave pulse sequence and its inverted signals with a rotational field towards the right when looking towards the motor shaft

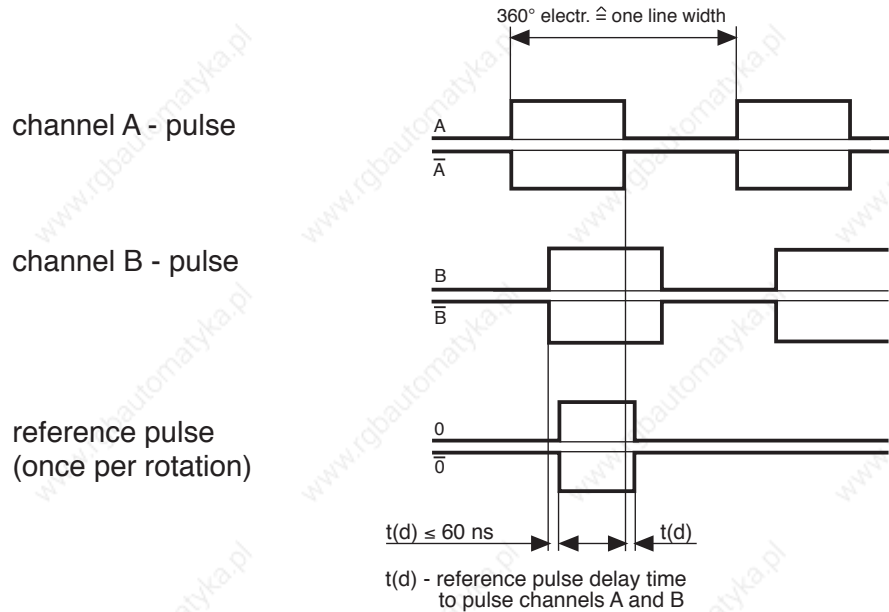

Recommended switching of the secondary electronics:

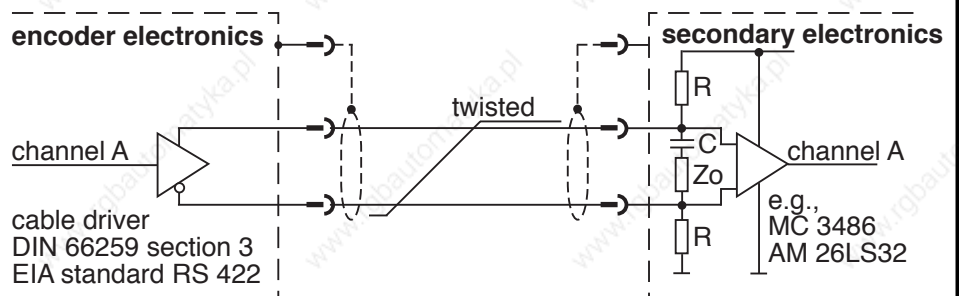

R = 4,7 k Ω ; prevents switching in the event of a break in the line
 C = 1 nF .. 10 nF; decreases the current consumption of the encoder
 Zo = 120 Ω ... 140 Ω ; as per characteristic wave impedance of cable

TDANBAUINKR5V

Fig 2.25: Incremental encoder, technical data, 5V voltage supplied, square-wave pulse

Voltage source:	10-16 V
Current consumption:	220 mA
Signal level:	$U(\text{high}) \geq 7 \text{ V}$; $U(\text{low}) \leq 2 \text{ V}$
Load capacity:	60 mA with "high" and "low" signal
Total operating time:	rise and fall time $\leq 200 \text{ ns}$
Maximum sampling frequency:	75 kHz
Incremental encoder signal:	TTL - square wave pulse sequence and its inverted signals with a rotational field towards the right when looking towards the motor shaft

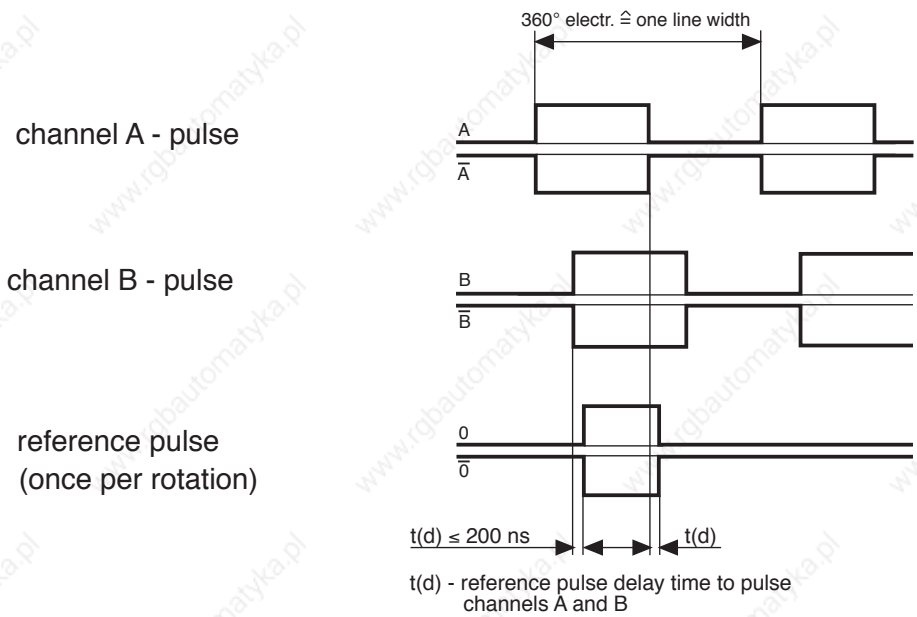

Recommended switching of the secondary electronics:

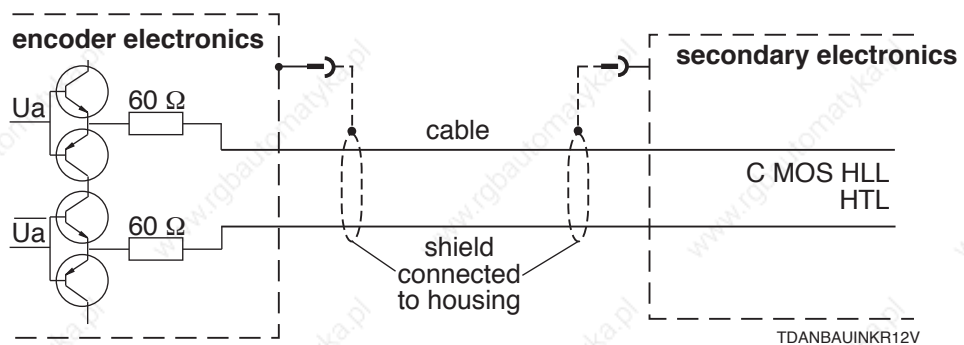

Fig 2.26: Incremental encoder, technical data, 12V voltage supplied, square-wave pulse

Voltage source: 5 V ± 5 %
Current consumption: 120 mA
Signal: two current signals I_{e1} and I_{e2} approaching sinusoidal shape
Signal size with load of 1 kΩ: I_{e1} approx. 11 μA ss
 I_{e2} approx. 11 μA ss
Reference signal: 1 signal I_{e0} per revolution
maximum scanning frequency: depends on slave electronics

Incremental encoder signals:

output signals

I_{e1}

I_{e2}

reference pulse

I_{e0}

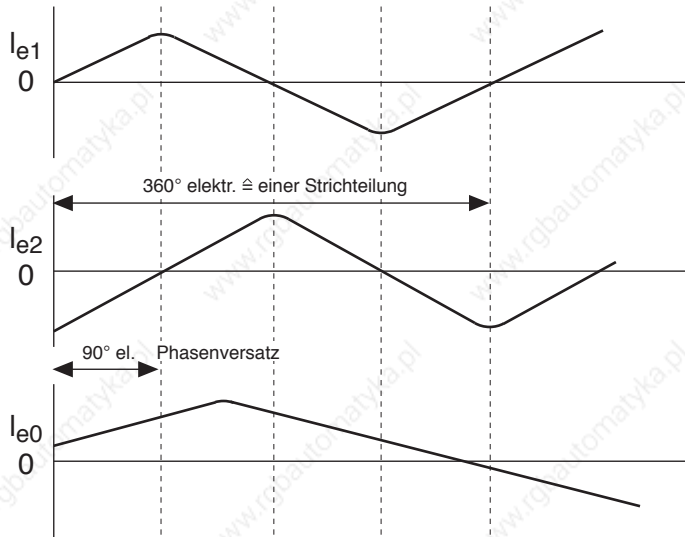

Speed:

$$0 \text{ to } \frac{f_{\max} \text{ (kHz)}}{Z} \cdot 10^3 \cdot 60 \text{ min}^{-1}$$

Z = number of lines

f_{\max} = maximum input frequency of slave electronics

TDInkrSINUS

Fig 2.27: Incremental encoder, technical data, 5V voltage supplied, sinusoidal signals

Setting the reference point

If INDRAMAT MAC servo motors are supplied with mounted incremental encoders and **motor output shafts with keyway**, then the reference point of the encoder is set to a defined angular position. This defined angular position of the reference point to the keyway of the motor output shaft makes it possible, if procedures are followed, to replace drives without adjustment work thus eliminating the risk of unnoticed dimensional displacements.

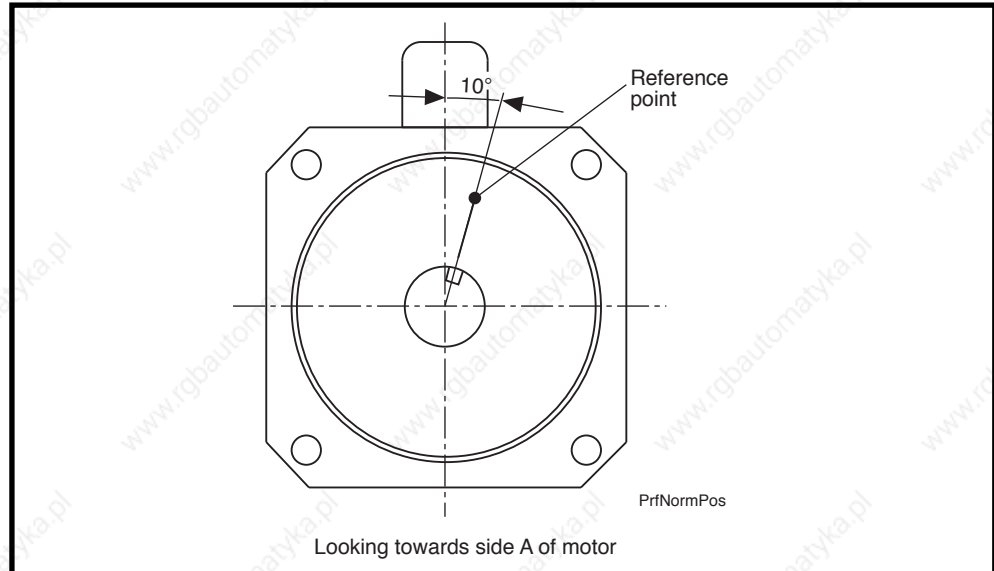

Fig 2.28: Standard position of the output shaft with keyway with encoder reference position in a MAC motor

The reference point can be mechanically changed if incremental encoders are used in MAC AC servo motors.

This is possible with:

- motors without surface cooling (natural convection)
- motors with radial surface cooling

This is not possible with:

- motors with axial surface cooling. The construction of the blower shroud determines the location of the incremental encoder connector with respect to the motor. This allocation changes, however, with the setting of the reference point!



When replacing the drives, changing the reference point setting results in considerable dimensional shifting. It must be checked by someone capable and authorized to do so and the reference point must, then, be reset. To replace a drive without causing this problem, we recommend that the defined reference point not be reset. INDRAMAT instead recommends an adaption of the reference dimension via the control unit.

Changing the
reference point setting



Procedure:

Only an electrician or properly trained personnel under the supervision of an electrician may set the reference point.

1. Switch the power section of the drives off.
2. Lock the motor shaft.

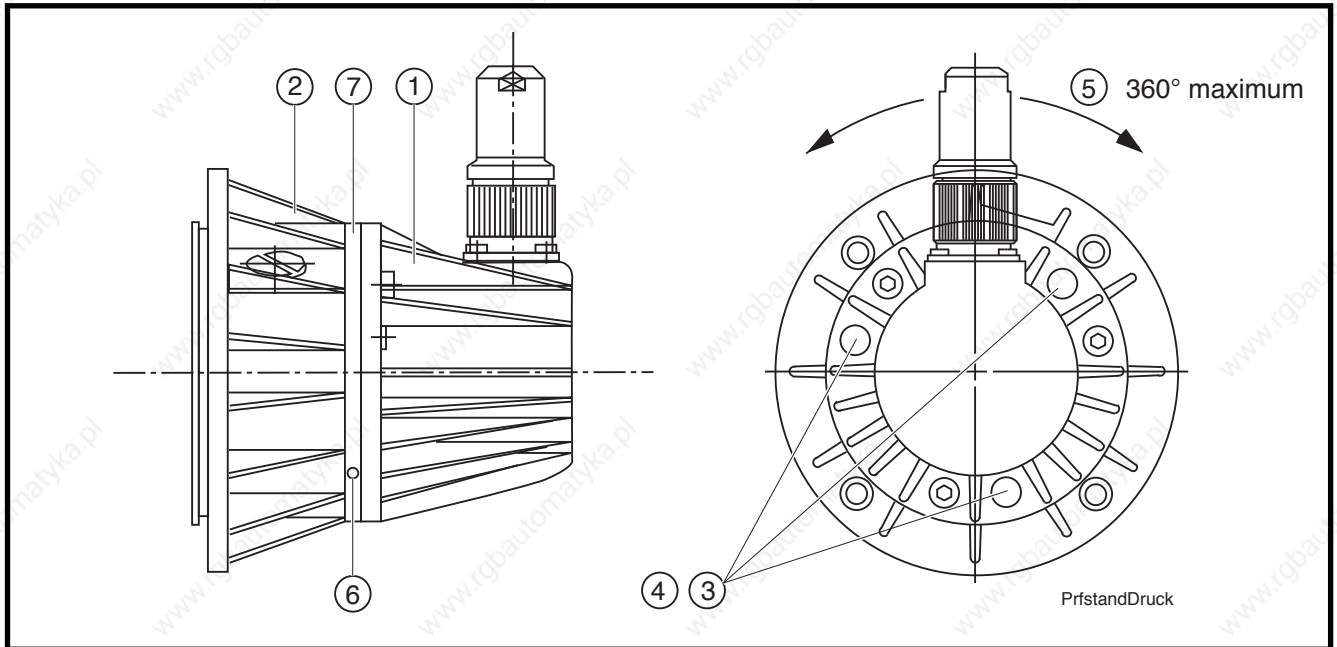

Fig 2.29: Standard die cast housing with mounting flange

3. Remove screw covers (3).
4. Release the allen screws (4) with one-half a turn.
5. Set the desired reference point by turning the encoder housing (1) with respect to the mounting flange (2). The radial drill hole (6), diameter 4 mm, in the plastic flange (7), can be used to assist this procedure. The encoder housing can be turned 360° in both directions. This changes the position of the encoder connector to the motor (interference contour).
6. Tighten allen screw (4) with 3,6 Nm.
7. Press screw covers (3) back into place.
8. Release motor shaft lock.
9. Switch power section of the drive back on.

2.4.5. Absolute Encoder

The absolute encoder supplies an unequivocal (absolute) position value for every position with a change in position.

These values remain available even after there has been an emergency off or a power failure. This eliminates the need for extensive referencing procedures of the individual axes.

The feedback position value remains available after the machine is switched back on even in the event that the axis of the machine were moved when in a currentless state.

In addition to the absolute position represented in terms of 360° , the absolute encoder also represents a defined number of resolutions in terms of absolute units. This resolution equals 24 bit, gray code, 4096 increments / $360^\circ \cdot 4096$ resolutions.

Figure 2.30 lists the designations of the absolute encoder.

Designation	No. of pulses	Supply source in V	MAC...					
			063	071	090	093	112	115
144SG	4096 • 4096	10-32	X					
154SG	4096 • 4096	10-32		X				
164SG	4096 • 4096	10-32			X	X	X	X

Fig 2.30: Designations of the absolute encoder

Voltage source:	5 V - 32 V DC, protected against polarity reversal
Current consumption:	≤ 3 W
Scan code:	Gray Code
Clockwise counting direction looking onto shaft:	rising
Data transmission:	synchronous, serial
Serial data output:	driver per EIA RS 422, secured against short-circuits
Monoflop time t_m:	15 μs < t_m < 25 μs
Clock frequency:	200 kHz
Minimum phase break:	30 μs
Data format:	24 Bit
Protection category in mounted state:	IP 65

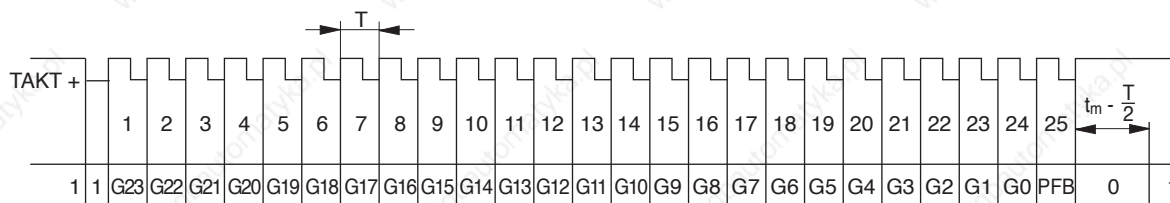

PFB = power failure bit
 T = pulse signal duration
 t_m = monoflop time

Power failure bit

If the power supply (> 5 V) is interrupted for periods exceeding 100 μs then the encoder information can be false.

The power failure bit (PFB) identifies this error. In the event of a voltage interrupt, the PFB in the serial information is set to logical 1 via a comparator.

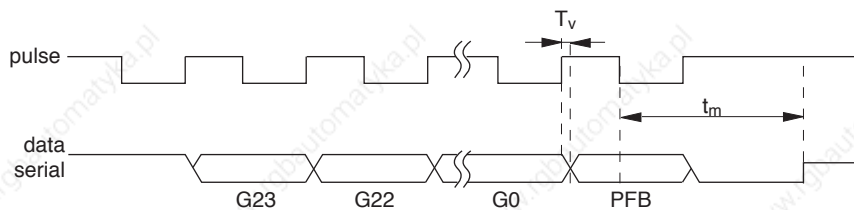

Delay time T_v : max 300 ns (clock (+) to data (+) or data (-))

Clock input circuitry

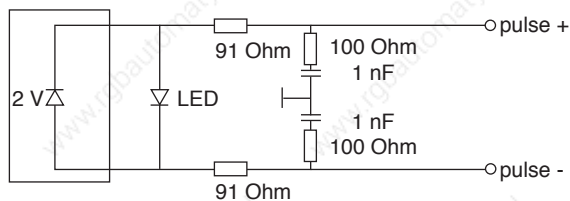

Data output circuitry

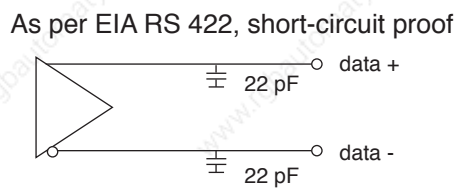

TDABSOLUT

Fig 2.31: Absolute encoder - technical data

Replacing the encoder

The absolute encoders which INDRAMAT mounts represent measuring systems of the highest quality developed for use on production machinery.

If an encoder should, however, at some point need to be replaced, then an entire replacement unit can be installed on site.



Do not use harsh cleansing agents to clean components.

The encoder may only be operated with a screwed on filler cap (10) (see Figure 2.32) as dirt contamination can cause it to fail.

The tools needed to work on the absolute encoder are:

- Allan key, 90° offset, SW3
- Allan key, straight, SW4
- torque key 0 to 5 Nm
- adjusting tool, part no.: 243 044



The absolute encoder may only be mounted or removed by an electrician or by trained personnel under the supervision of an electrician.

Removing the absolute encoder

Procedure:

1. Switch power section of drive off.
2. Switch control voltage off.
3. Pull out encoder.

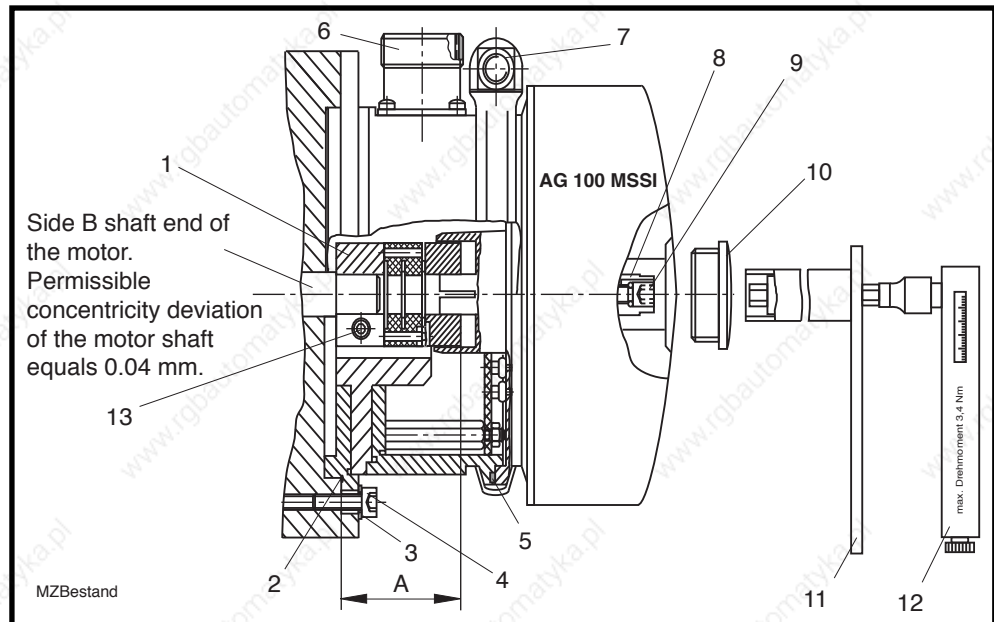

Fig 2.32: Components of an absolute encoder with tools and torque key

4. Remove filler cap (10) (Fig 2.32) out of encoder housing.
5. Place adjusting tool (11) onto the hexagon of the expander (8) and hold in this position.
6. Pull out the expander (9) with the key (SW4) using approximately six turns. **Do not use** the adjusting tool for this task!
7. Release screws (4) with the key (SW4) and pull the mounted encoder unit carefully out.
8. Check the coupling unit for wear and tear.

- If necessary, pull slotted screw out (13) with key (SW3) and pull out the clamped coupling unit of the motor shaft.

Preparing to mount the absolute encoder

Procedure:

- Remove the new unit to be mounted from its packaging.
- Remove the filler cap (10) from the encoder housing.
- Make sure there is no tension in the expander (8).
- Check whether the enclosed coupling unit can easily be slid onto the expander (8). If not, put adjusting tool onto hexagon of the expander (8) and hold. Then, using an Allan key (SW4) turn the expander (9) six turns to the left. There should now be no tension in the expander. This is the prerequisite for correctly mounting the encoder unit.

Mounting the absolute encoder

Procedure:

- Switch power section of drive off.
- Switch control voltage off.
- Remove servo motor cover (see Figure 2.33).
- Remove all grease from side B of the motor.

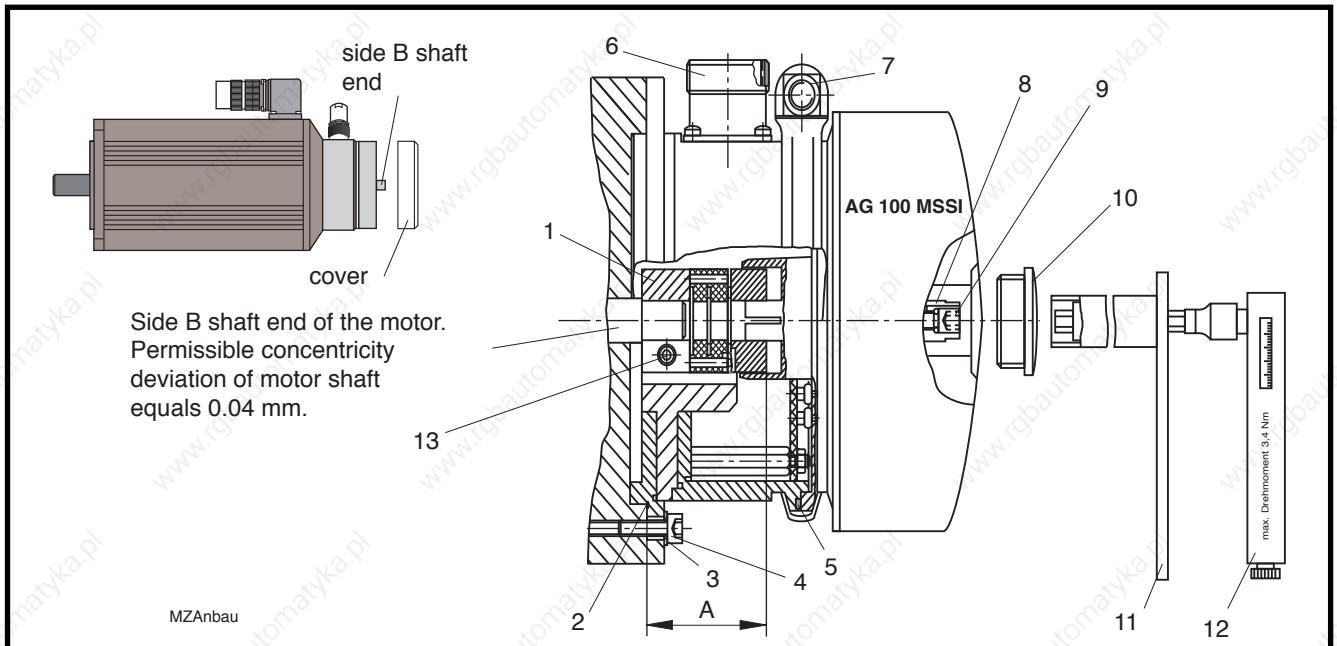

Fig 2.33: Mounting the absolute encoder

- Push the coupling unit (1) onto side B of the shaft end.
- Set dimension A (distance flange mounting surface to the end of the coupling unit). Dimension A: MAC 063: 39.7 ± 0.5 mm
Dimension A: MAC 071 - 115: min. 35.5 mm/max. 37 mm
- Tighten screw (13) with key (SW3) 3.4 Nm.
- Check whether O-ring (2) is properly mounted.
- Place unit carefully onto motor without tipping. Feed expander (8) into coupling unit at the same time.
- Turn connector (6) so that the angle is set for the respective motor (see dimensional data, sections 3 to 8).
- Mount unit with screws (4) and washers (3) to the motor.
Tightening torque: 2.8 Nm for MAC 063
5.7 Nm for MAC 071 - 115
- Place adjusting tool (11) onto expander (8) and hold in this position.

13. Tighten expander (9) with torque key (12). Torque: 3.4 Nm.
14. Screw filler cap (10) into encoder housing.
15. Put absolute encoder connector into place.
16. Apply power.
17. Switch drive on and check whether encoder is functional.
18. Run a homing procedure.

Setting the reference point of the absolute encoder

If INDRAMAT MAC servo motors are delivered with absolute encoders mounted, then it is possible to set the reference point in several different ways.

Procedure 1

Set zero point of absolute encoder to the mechanical reference point.

1. Set servo drive to the reference point (in jog mode).
2. Connect absolute encoder to the control unit.
3. Release the connection absolute encoder to motor shaft (adjusting tool, part no.: 243 044).
4. Turn absolute encoder to zero point; evaluate at control unit.
5. Conduct a test run.

Procedure 2

Set the end of the measuring range of the absolute encoder to the mechanical end of the axis.

1. Run the mechanical system into the end position.
2. Connect the absolute encoder to the control unit.
3. Release the connection absolute encoder to motor shaft (adjusting tool, part no.: 243 044).
4. Turn the absolute encoder to relevant end position.
5. Re-establish absolute encoder - motor shaft connection.
6. Conduct a test run.

Procedure 3

Conduct an electronic zero point displacement in the control unit (depends on the control unit used)

1. Absolute encoder remains clamped to the servo drive.
2. The drive is firmly connected to the mechanical system.
3. Run the servo drive to the reference point (in jog mode).
4. The absolute value of the encoder is read in and interpreted as the zero point by the control unit.

2.5. Torque-Speed Characteristics

This section contains explanations about the torque-speed characteristics. These are depicted for each type of motor in sections 3.2, 4.2 through 8.2.

The curves of some of the motors may deviate from the features described here. These deviations are, however, then relevantly documented

What is depicted The operating curves depict:

- the torque limiting data,
- the speed limiting data and
- the operating curves.

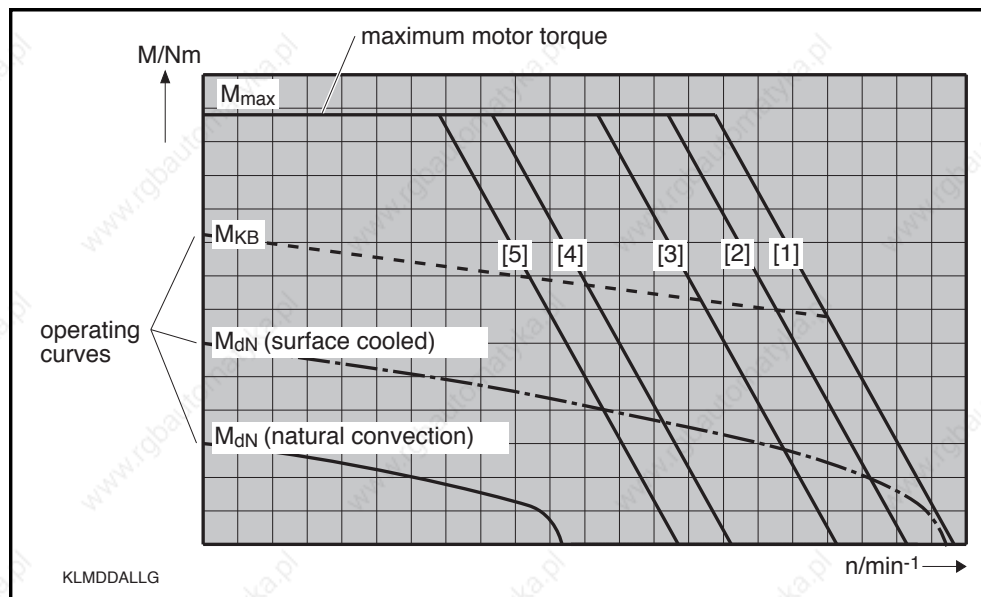

Fig 2.34: The torque-speed characteristics illustrated

Usage The torque-speed characteristics can be used:

- to record information from the selection documentation,
- to determine the possible maximum usable speed for a special application with known torque requirements and
- to check whether the application remains within the thermal limits of the motor. The effective torque for a critical cycle must be below the S1 continuous operating characteristics curve of the arithmetically averaged speed.

Limiting value for torque

The horizontal line M_{max} depicts the theoretically possible maximum torque of the motor. The drive can limit this maximum torque resulting from the various motor-controller combinations. It is outlined in the selection documentation.

Limiting value for speed

Maximum motor speed is determined by the DC bus voltage produced by the supply source at the drive. Depending upon the DC bus voltage at the drive, maximum torque drops at a breaking point

DC bus with a regulated power supply

In the case of those supply modules with a regulated power supply, the power data of the drive-motor combination are not dependent on the fluctuations of the mains voltage.

DC bus voltage with an unregulated power supply

In the case of those supply modules with an unregulated power supply, the power data of the drive-motor combination are dependent on the fluctuations of the mains voltage. Varying power data are achieved under the following conditions at the mains:

- 10 % overvoltage
- nominal voltage
- 10 % undervoltage

The declining lines are numbered. The following allocations apply:

- [1] -DC bus voltage with a regulated power supply (e.g., KDV 4, TVD, KVR, TVR) or an unregulated power supply if AC mains input voltage is 10% higher than the rated 3 x 230 volts AC (e.g., TVM 2, KDV 1, KDV 2, KDV 3, DSC 3)
- [2] -DC bus voltage with an unregulated power supply connected to a three-phase mains rated at 3 x AC 230 V (e.g., TVM 2, KDV 1, KDV 2, KDV 3, DSC 3)
- [3] -DC bus voltage with an unregulated power supply connected to three-phase mains rated at 3 x AC 230 V with 10% undervoltage (e.g., TVM 2, KDV 1, KDV 2, KDV 3, DSC 3)

Furthermore, the speed could be limited by the tacho voltage of the tacho generator.

Allocate the curves determined by the tacho voltage of the tacho generator as follows:

- [4] -tacho generator with 3 V/1000 min⁻¹ tacho voltage
- [5] -tacho generator with 6 V/1000 min⁻¹ tacho voltage
- [6] -tacho generator with 1.5 V/1000 min⁻¹ tacho voltage

Operating curves

The operating curves depict the permissible continuous torque M_{dN} (operating mode S1) and the intermittent operating torque M_{KB} (operating mode S6 per DIN VDE 0530; 7/91 edition).

The following allocations apply:

- S1-continuous curve of the motor with natural convection
- - - - - S1-continuous curve of a motor with surface cooling
- - - - - S6-intermittent operating curve:
at an ON time of 25 % of the motor with natural convection or with the ON time indicated in the curve with surface cooling. Maximum duty cycle time is indicated in Figure 2.35.

Motor series MAC ...	Maximum duty cycle time
063	10 min.
071, 090, 093, 112, 115	15 min.

Fig 2.35: Maximum duty cycle time with intermittent operations

Empty page

3. MAC 063

3.1. Technical Data

Designation	Symbol	Unit	Motor type MAC ...			
			063 A - - - ES	063 B - - - GS	063 C - - - MS	063 D - - - JS
Nominal motor speed ¹⁾	n	min ⁻¹	3500	3500	3500	3500
Continuous torque at standstill ²⁾	M _{dN}	Nm	0.8 (1.0) ⁵⁾	1.5 (1.7) ⁵⁾	2.1(2.7) ⁵⁾	2.7 (3.5) ⁵⁾
Continuous current at standstill	I _{dN}	A	2.2 (2.7) ⁵⁾	3.6 (4.0) ⁵⁾	4.1(5.3) ⁵⁾	5.1 (6.6) ⁵⁾
Rotor moment of inertia ³⁾	J _M	kgm ²	2.4 x 10 ⁻⁴	3.2 x 10 ⁻⁴	4.0 x 10 ⁻⁴	4.8 x 10 ⁻⁴
Torque constant at 20 °C	K _m	Nm/A	0.370	0.42	0.51	0.53
Windings resistance at 20 °C	R _A	Ohm	9.6	4.1	2.8	1.9
Windings inductance	L _A	mH	9.1	3.9	3.2	2.5
Maximum peak of pulse current	I _{peak}	A	12	19	22	27
Thermal time constant	T _{th}	min	30 (15) ⁵⁾	30 (15) ⁵⁾	30 (15) ⁵⁾	30 (15) ⁵⁾
Mass ⁴⁾	m _M	kg	3.2	3.9	4.6	5.3
			063 A - - - RS	063 B - - - JS	063 C - - - HS	063 D - - - FS
Nominal motor speed ¹⁾	n	min ⁻¹	6000	6000	6000	6000
Continuous torque at standstill ²⁾	M _{dN}	Nm	0.8 (1.0) ⁵⁾	1.5 (1.7) ⁵⁾	2.1(2.7) ⁵⁾	2.7 (3.5) ⁵⁾
Continuous current at standstill	I _{dN}	A	3.5 (4.4) ⁵⁾	5.8 (6.6) ⁵⁾	6.8 (8.7) ⁵⁾	8.4 (11.0) ⁵⁾
Rotor moment of inertia ³⁾	J _M	kgm ²	2.4 x 10 ⁻⁴	3.2 x 10 ⁻⁴	4.0 x 10 ⁻⁴	4.8 x 10 ⁻⁴
Torque constant at 20 °C	K _m	Nm/A	0.230	0.26	0.31	0.32
Windings resistance at 20 °C	R _A	Ohm	3.7	1.6	1.1	0.7
Windings inductance	L _A	mH	3.5	1.5	1.2	0.9
Maximum peak of pulse current	I _{peak}	A	19	31	36	46
Thermal time constant	T _{th}	min	30 (15) ⁵⁾	30 (15) ⁵⁾	30 (15) ⁵⁾	30 (15) ⁵⁾
Mass ⁴⁾	m _M	kg	3.2	3.9	4.6	5.3

¹⁾ The usable motor speed is determined by the drive used.
 Only those usable speeds n_{max} found in the selection lists of the motor-drive combinations are binding.
²⁾ With 60K overtemperature at the motor housing.
 Continuous torque can be limited by the drive. See selection data.
³⁾ With tacho-generator, without holding brake
⁴⁾ With tacho-generator, without holding brake, without blower.
⁵⁾ Parenthetical values apply to versions with surface cooling.

Fig 3.1: Type-dependent motor data

Designation	Symbol	Unit	Data
Permissible ambient temperature	T _{um}	°C	0 ... + 45
Permissible storage and transport temperature	T _L	°C	-20 ... +80
Maximum installation elevation		m	1000 meters above sea level
Protection category			IP 65 ¹⁾
Insulation classification			F
Housing coat			Black prime coat (RAL 9005)
Voltage constant of the tacho-generator	C _w	Vs/rad V/min ⁻¹	0,0143 1.5/1000

¹⁾ Except for the shaft leadthrough in drive shafts, without sealing ring. Protection category is then IP 50.

Fig 3.2: General data MAC 063

Designation	Symbol	Unit	Data holding brake
Principle of action			electrically-actuated release
Holding torque	M _H	Nm	3.0
Nominal voltage	U _N	V	DC 24 ± 10%
Nominal current	I _N	A	0.6
Moment of inertia	J _B	kgm ²	0.38 x 10 ⁻⁴
Release delay	t _L	ms	30
Clamping delay	t _K	ms	15
Mass	m _B	kg	0.55

Fig 3.3: Technical data - holding brake

Designation	Symbol	Unit	Data surface cooling	
			Axial cooling	Radial cooling
Power consumption	S _N	VA	20/18	16/14
Nominal voltage	U _N	V	AC 230 or 115 ¹⁾	AC 230 or 115 ¹⁾
Frequency	f	Hz	50/60	50/60
Mass	m _L	kg	approx. 1.1 ²⁾	approx. 1.0 ²⁾
Protection category blower unit			IP 24	IP 24
Protection category blower motor			IP 44	IP 44
¹⁾ 115 V special design ²⁾ Blower shroud for motor with tacho feedback.				

Fig 3.4: Technical data - surface cooling

3.2. Torque-Speed Characteristics

MDD 063 A - - - ES
3500 min⁻¹

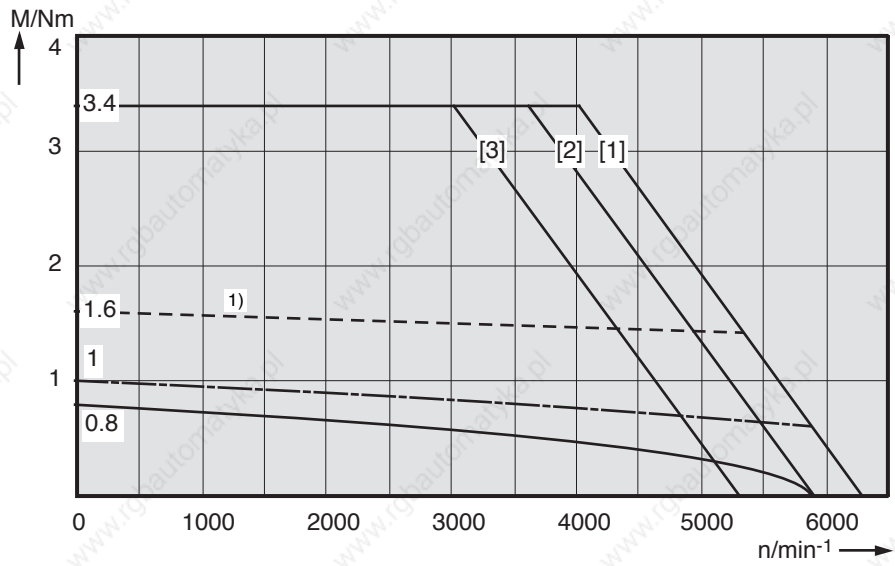

MDD 063 A - - - RS
6000 min⁻¹

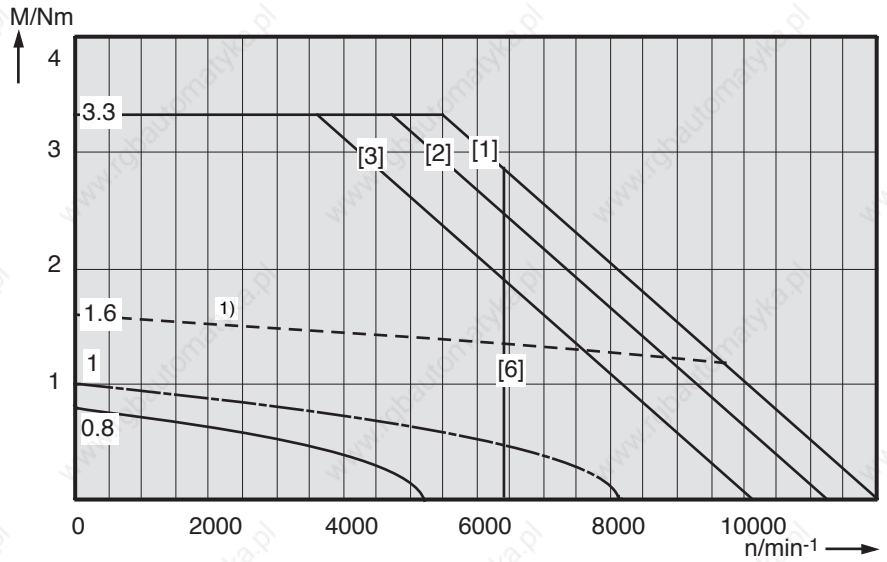

MDD 063 B - - - GS
3500 min⁻¹

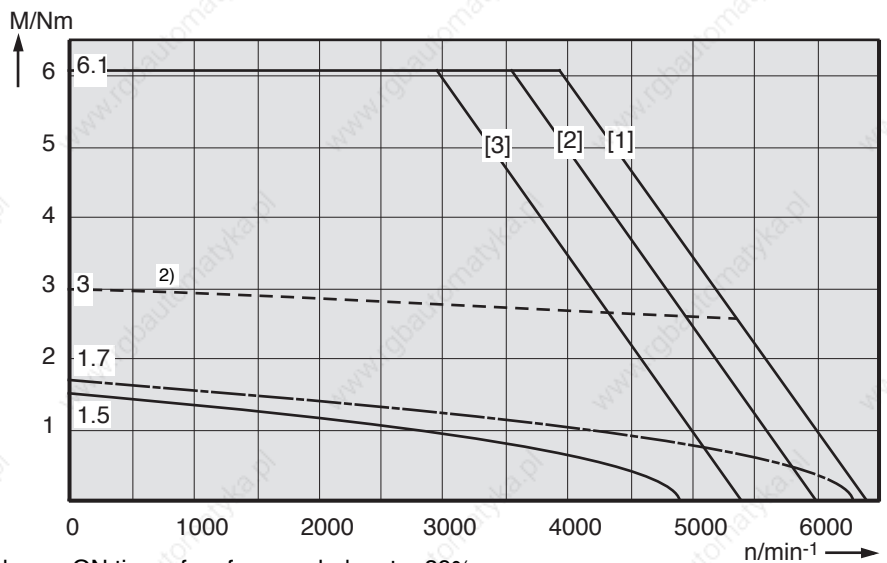

1) shown: ON time of surface-cooled motor 39%
2) shown: ON time of surface-cooled motor 32%

Fig 3.5: Torque-speed Characteristics MAC 063

MDD 063 B - · · - JS
6000 min⁻¹

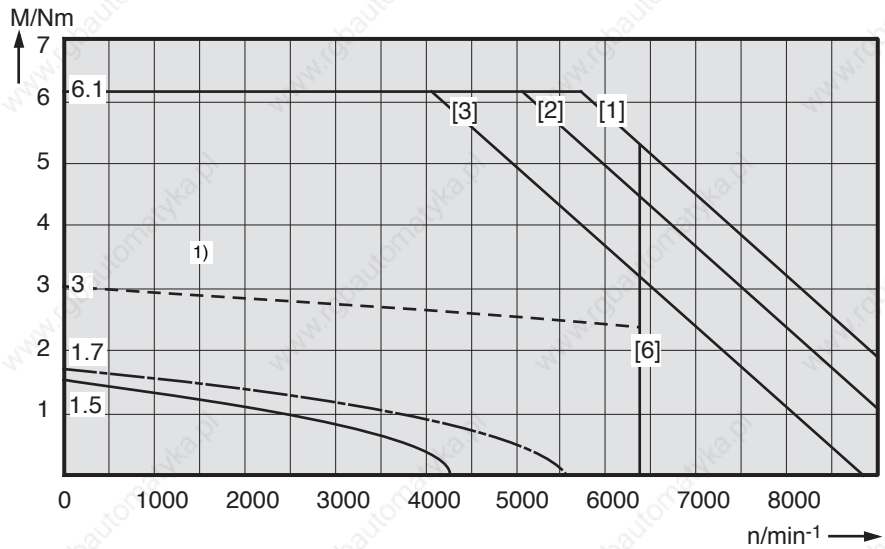

MDD 063 C - · · - MS
3500 min⁻¹

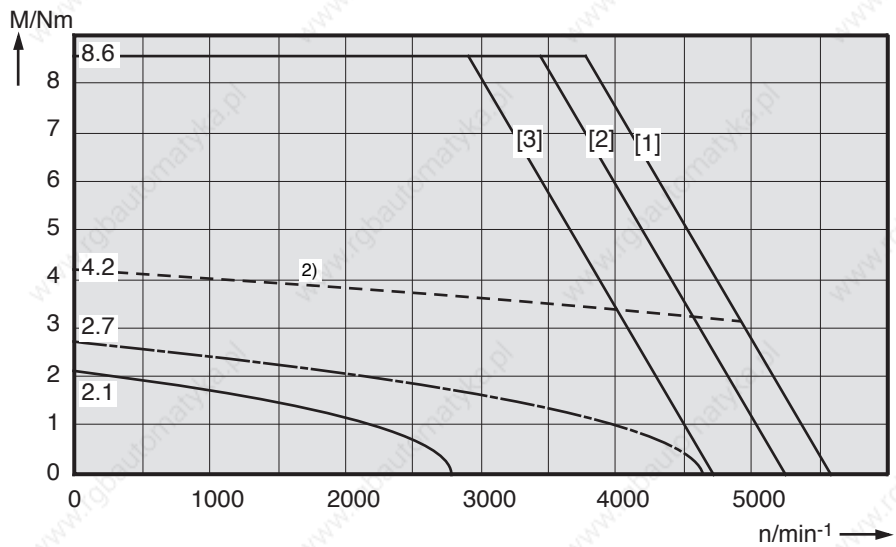

MDD 063 C - · · - HS
6000 min⁻¹

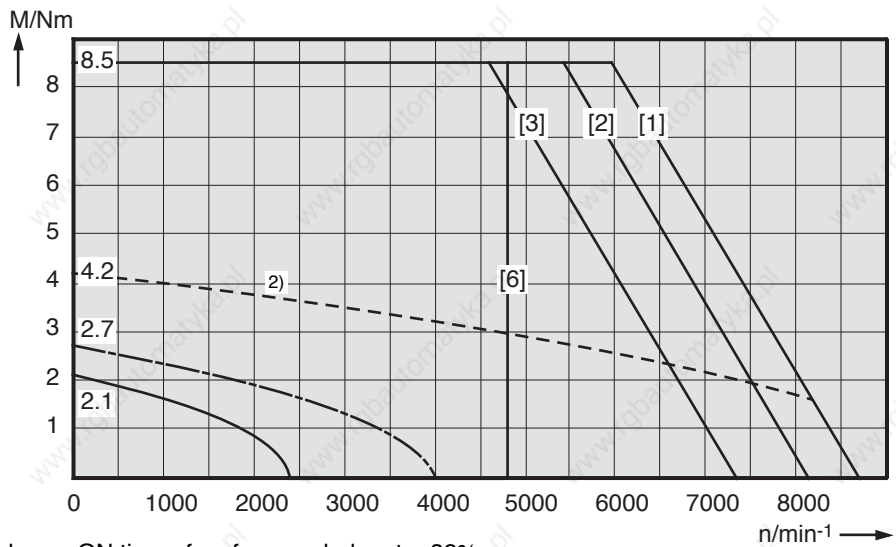

1) shown: ON time of surface-cooled motor 32%
2) shown: ON time of surface-cooled motor 41%

Fig 3.6: Torque-speed characteristics MAC 063

MDD 063 D - - - JS
3500 min⁻¹

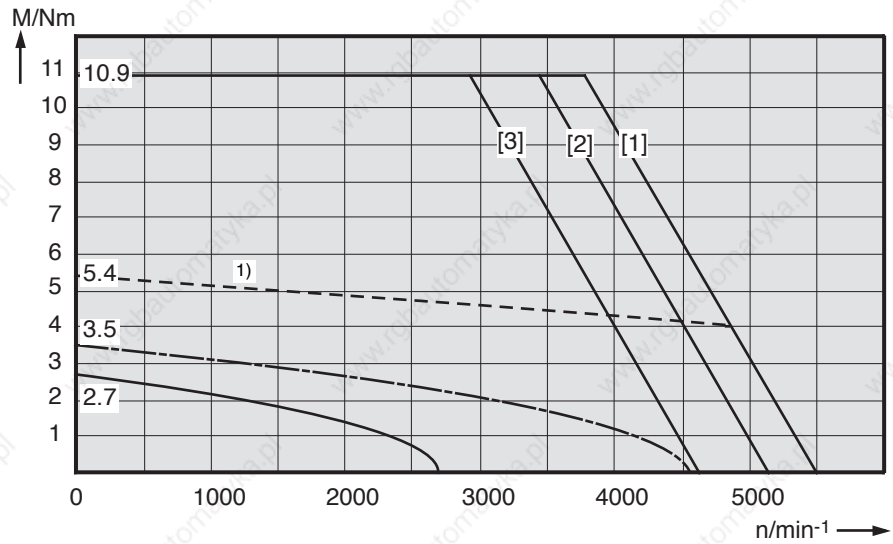

MDD 063 D - - - FS
6000 min⁻¹

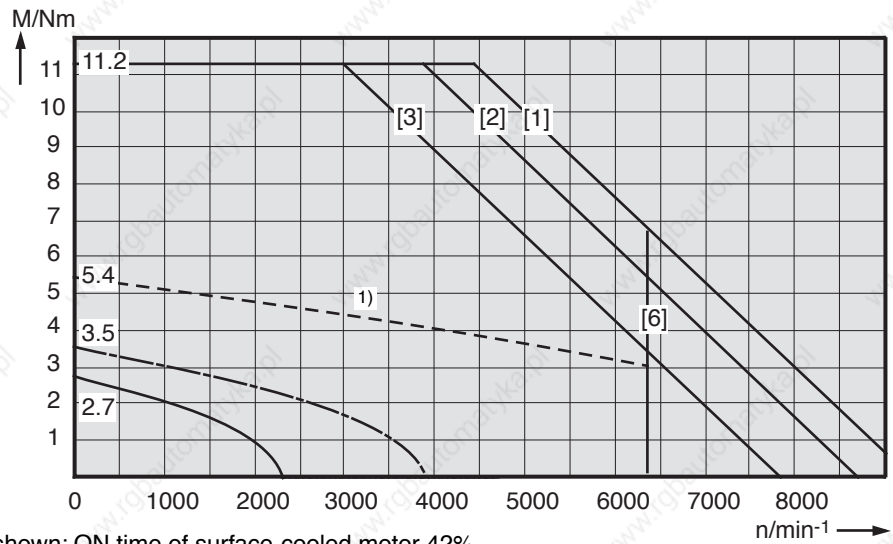

1) shown: ON time of surface-cooled motor 42%

Fig 3.7: Torque-speed characteristics MAC 063

3.3. Shaft Load Capacity

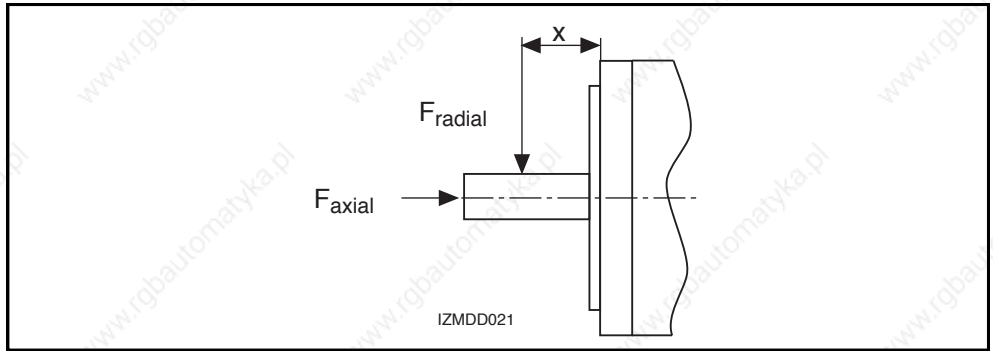

Fig 3.8: Shaft load

Permissible radial force
 F_{radial}

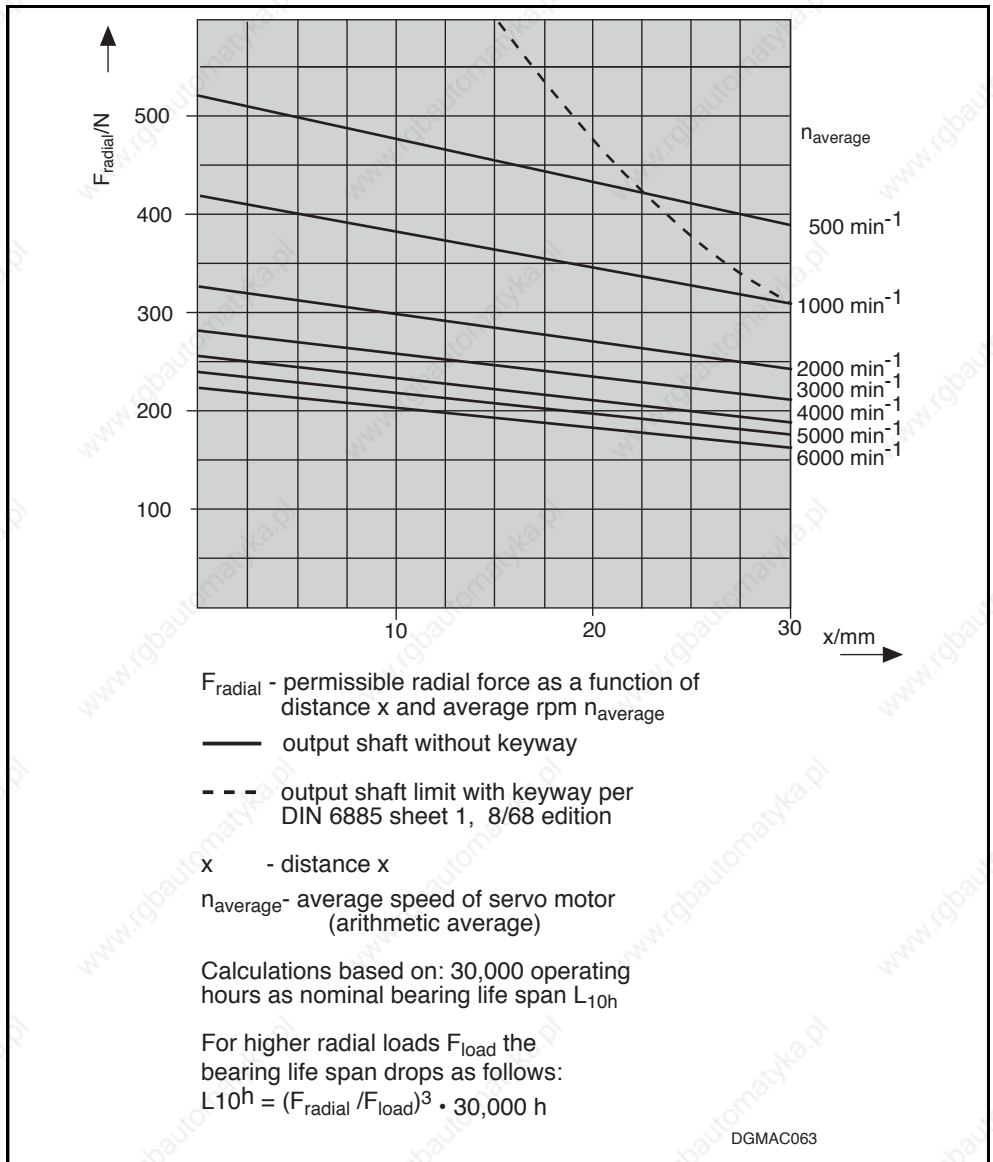

Fig 3.9: Permissible radial force

Permissible axial force
 F_{axial}

$$F_{axial} = 0.57 \cdot F_{radial}$$

F_{axial} - Permissible axial force

F_{radial} - Permissible radial force

3.4. Dimensional Data - Natural Convection

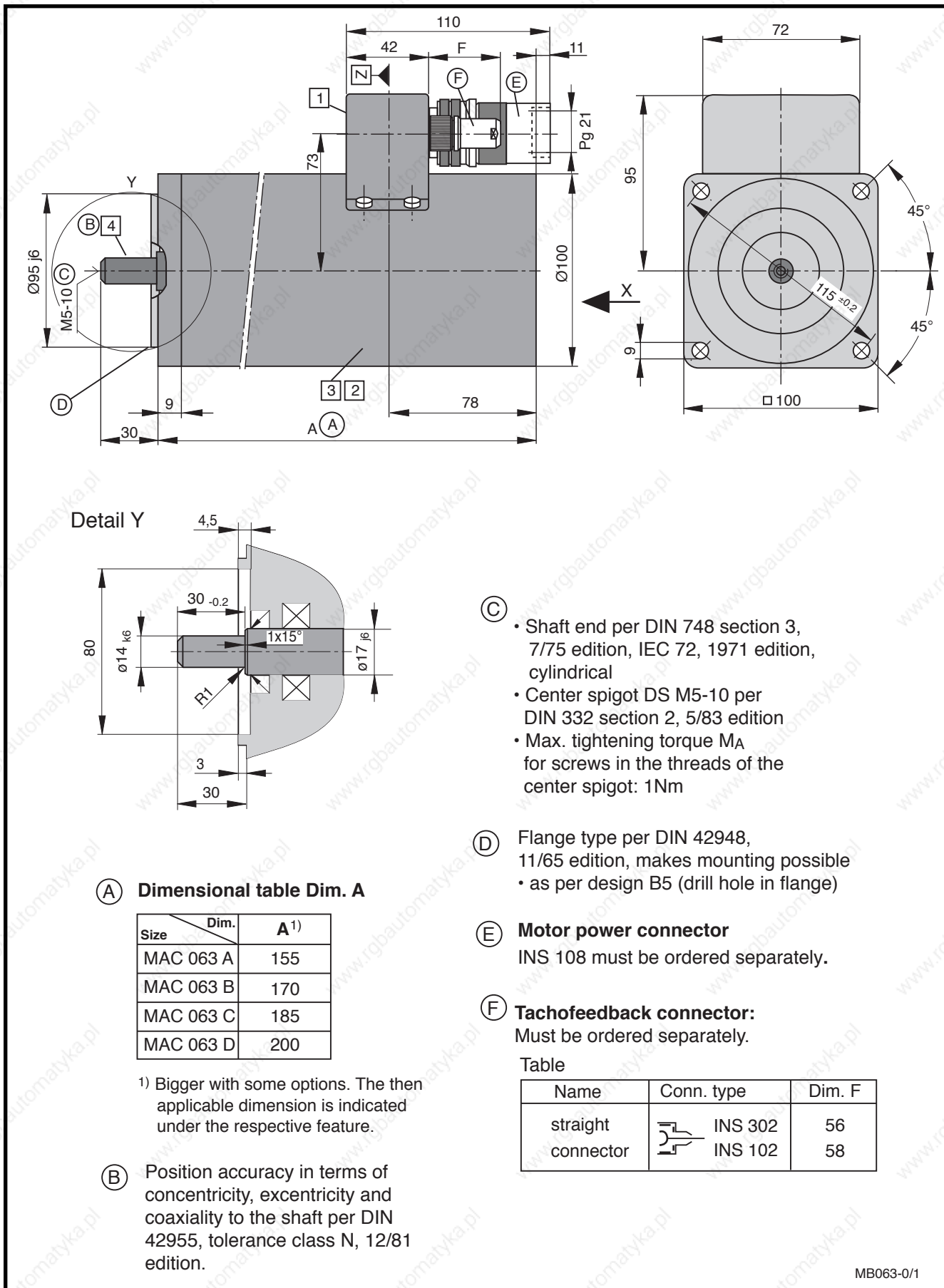

Fig 3.10: Dimensional data - MAC 063 (natural convection)

MB063-0/1

Available options

1 Power connection

The output direction of the electrical power connector is selected at the time the order is placed. Possible output directions are:

- to side A
- to side B

The drawing depicts side B as output direction. The dimensions of any other direction are obtained by a virtual turning of the connector housing around the Z axis.

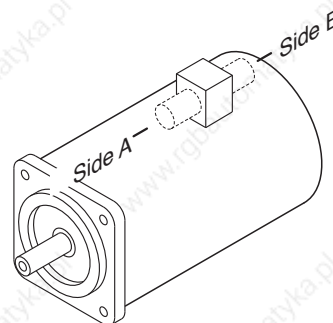

2 Motor version

- Tachofeedback and second shaft end

View X:

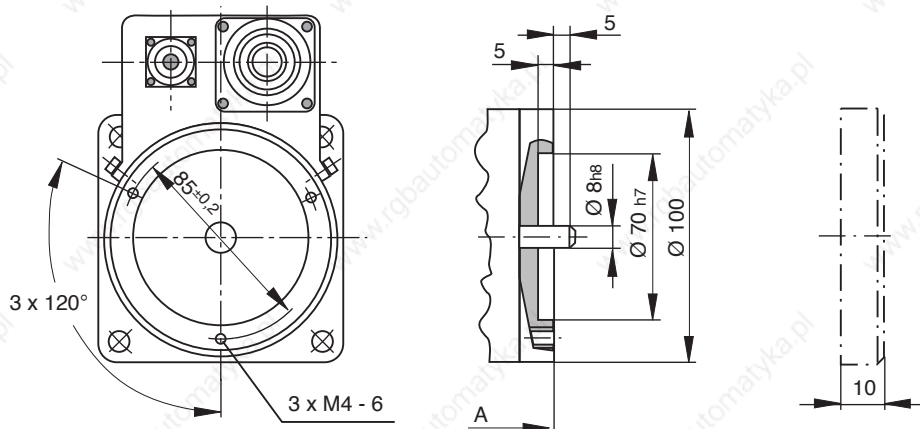

Table	Dim. A
MAC 063 A	162.5
MAC 063 B	177.5
MAC 063 C	192.5
MAC 063 D	207.5

Cover mounted at delivery.

- Tachofeedback and mounted incremental encoder

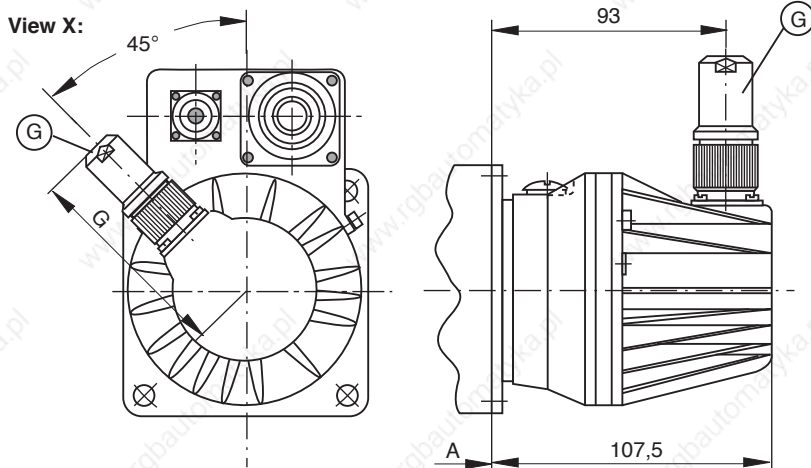

Table	Dim. A
MAC 063 A	162.5
MAC 063 B	177.5
MAC 063 C	192.5
MAC 063 D	207.5

G Incremental encoder connector
Must be ordered separately.

Name	Conn. type	Dim. G
straight conn.	INS 301	88
	INS 101	90
angle conn.	INS 351 INS 311	86

- Tachofeedback and mounted absolute encoder (see following page)

MB063-0/2

Fig 3.11: Dimensional data - MAC 063 - available options - (natural convection)

Available options

- Tachofeedback and mounted absolute encoder

View X:

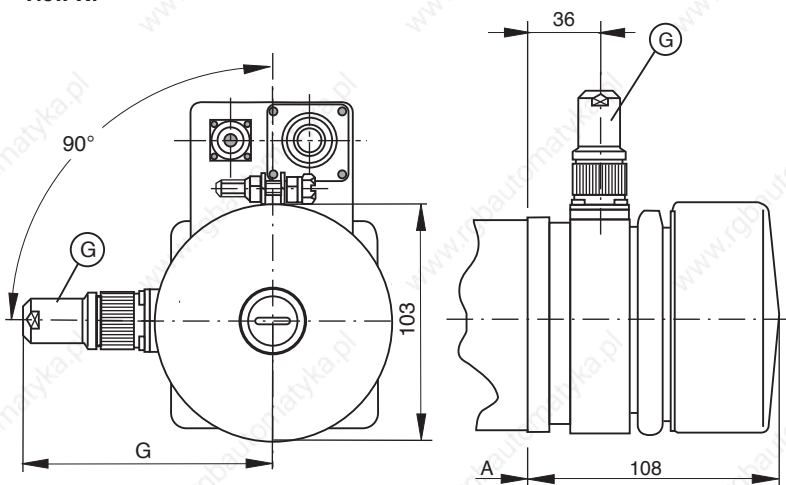

Table	Dim. A
MAC 063 A	162.5
MAC 063 B	177.5
MAC 063 C	192.5
MAC 063 D	207.5

G Absolute encoder conn.
Must be ordered separately.

Name	Conn. type	Dim. G
straight conn.	INS 326	104
	INS 92	106
angle conn.	INS 322	102

3 Blocking brake

- without blocking brake
Dim. A retained
- Standard blocking brake: 3 Nm

Table for blocking brake

Dim. Size	Vers. 2 A	Vers. 3 & 4 A
MAC 063 A	180	187.5
MAC 063 B	195	202.5
MAC 063 C	210	217.5
MAC 063 D	225	232.5

Vers. 2 =
Motor with tachofeedback

Vers. 3 =
Motor with tachofeedback and second shaft end

Vers. 4 =
Motor with tachofeedback and mounted encoder

4 Output shaft

- plain shaft (recommended type)
- with keyway per DIN 6885 sh. 1, 8/68 edition
(Note! balanced with entire key.)

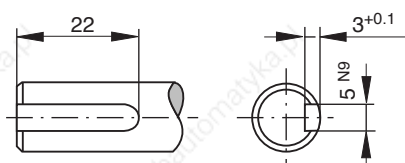

Matching key: DIN 6885-A 5 x 5 x 22
Must be ordered separately.

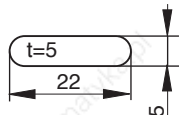

MB063-0/3

Fig 3.12: Dimensional data - MAC 063 - available options - (natural convection)

3.5. Dimensional Data - Radial Cooling

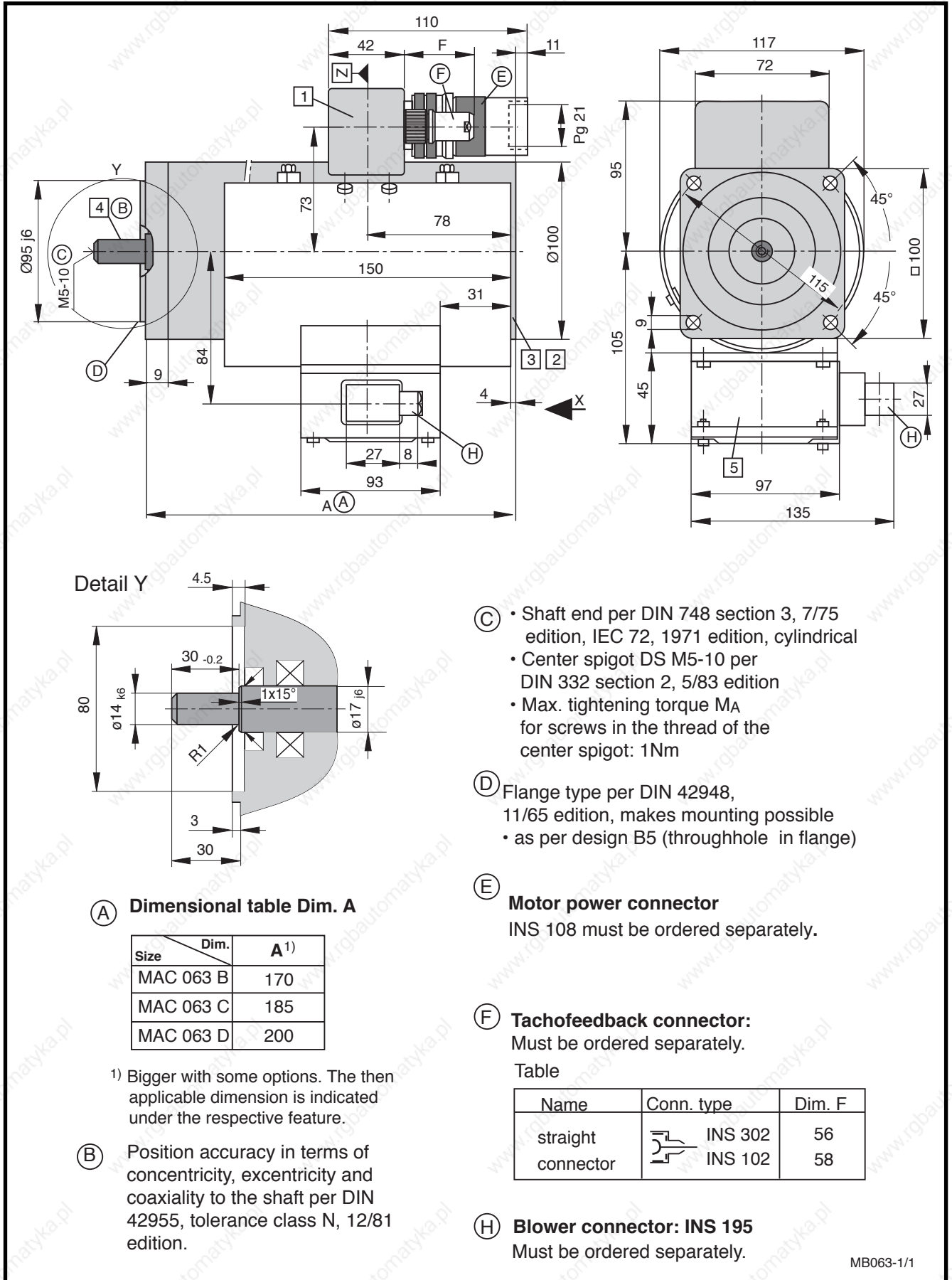

Fig 3.13: Dimensional data - MAC 063 (radial cooling)

Available options

1 Power connection

The output direction of the electrical power connector is selected at the time the order is placed. Possible output directions are:

- to side A
- to side B

The drawing depicts side B as output direction. The dimensions of any other direction are obtained by a virtual turning of the connector housing around the Z axis.

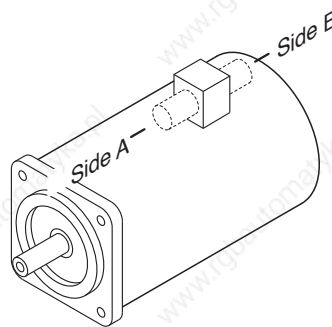

2 Motor version

- Tachofeedback and second shaft end

View X:

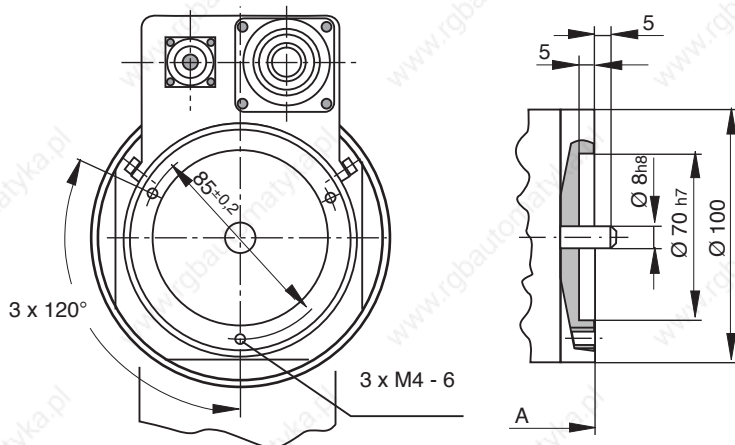

Table	Dim. A
MAC 063 B	177.5
MAC 063 C	192.5
MAC 063 D	207.5

- Tachofeedback and mounted incremental encoder

View X:

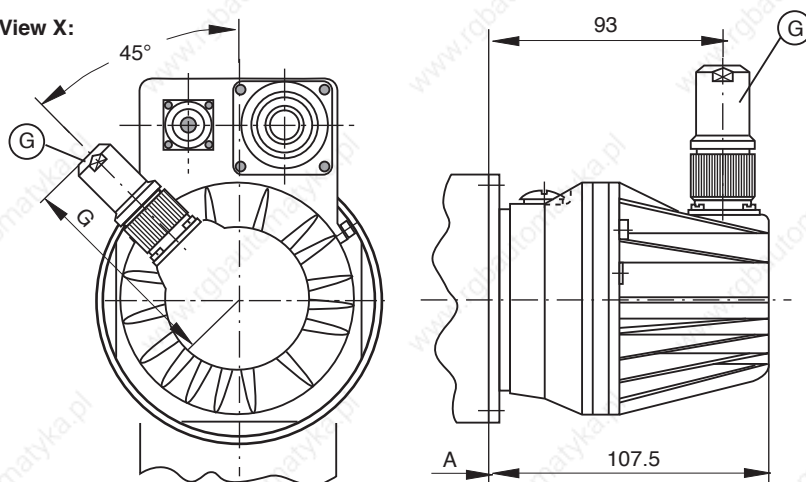

Table	Dim. A
MAC 063 B	177.5
MAC 063 C	192.5
MAC 063 D	207.5

G Incremental encoder connector

Must be ordered separately.

Name	Conn. type	Dim. G
straight conn.	INS 301	88
	INS 101	90
angle conn.	INS 351 INS 311	86

- Tachofeedback and mounted absolute encoder (see following page)

MB063-1/2

Fig 3.14: Dimensional data - MAC 063 - available options - (radial cooling)

Available options

- Tachofeedback and mounted absolute encoder

View X:

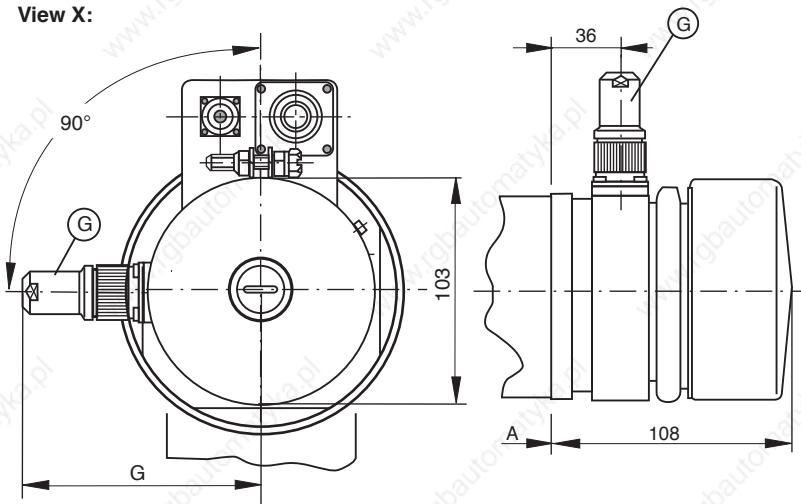

Table	Dim. A
MAC 063 B	177.5
MAC 063 C	192.5
MAC 063 D	207.5

G Absolute encoder conn.
Must be ordered separately.

Name	Conn. type	Dim. G
straight conn.	INS 326	104
	INS 92	106
angle conn.	INS 322	102

3 Blocking brake

- without blocking brake
Dim. A retained
- Standard blocking brake: 3 Nm

Table for blocking brake

Dim. Size	Vers. 2 A	Vers. 3 & 4 A
MAC 063 B	195	202.5
MAC 063 C	210	217.5
MAC 063 D	225	232.5

Vers. 2 = Motor with tachofeedback

Vers. 3 = Motor with tachofeedback and second shaft end

Vers. 4 = Motor with tachofeedback and mounted encoder

4 Output shaft

- plain shaft (recommended type)
- with keyway per DIN 6885 sh. 1, 8/68 edition
(Note! balanced with entire key.)

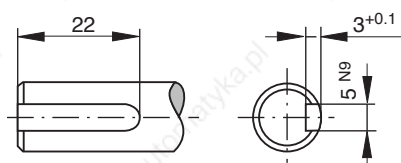

Matching key: DIN 6885-A 5 x 5 x 22
Must be ordered separately.

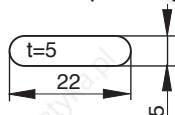

5 Blower arrangement

Looking towards motor shaft.

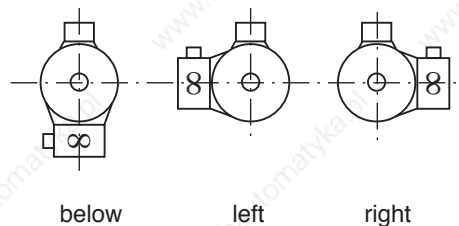

MB063-1/3

Fig 3.15: Dimensional data - MAC 063 - available options - (radial cooling)

3.6. Dimensional Data - Axial Cooling

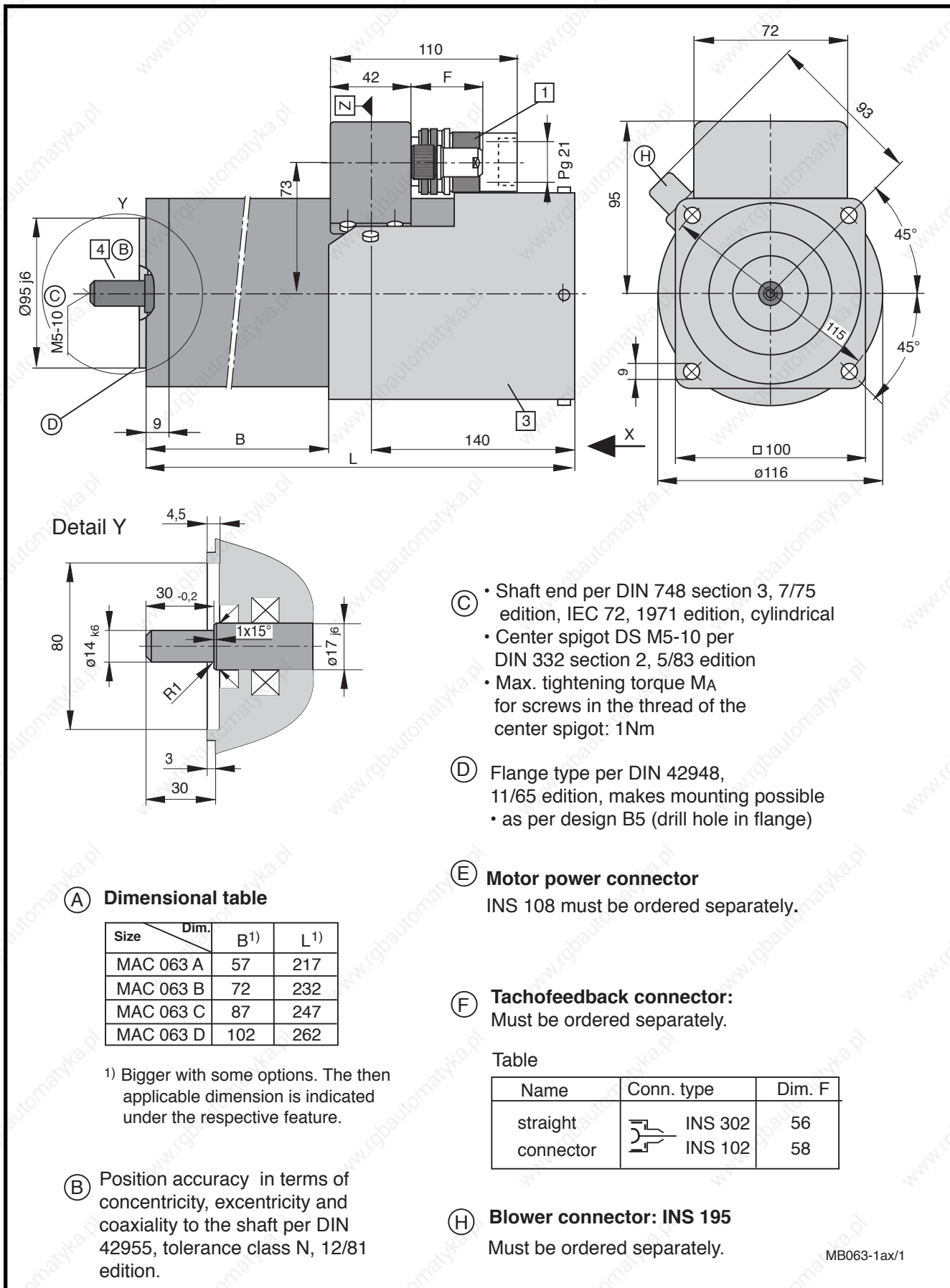

Fig 3.16: Dimensional data - MAC 063 (axial cooling)

MB063-1ax/1

Available options

1 Power connection

The output direction of the electrical power connector is selected at the time the order is placed. Possible output directions are:

- to side A
- to side B

The drawing depicts side B as output direction. The dimensions of any other direction are obtained by a virtual turning of the connector housing around the Z axis.

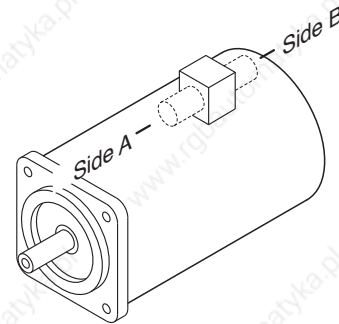

3 Blocking brake

- without brake, dimensions B and L are retained
- Standard blocking brake: 3 Nm

Table with blocking brake
3 Nm holding torque:

Size	Dim.	B	L
MAC 063 A		82	242
MAC 063 B		97	257
MAC 063 C		112	272
MAC 063 D		127	287

4 Output shaft

- plain shaft (preferred type)
- with keyway per DIN 6885 sheet 1, 8/68 edition
(Note! balanced with entire key.)

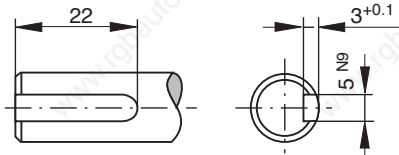

Matching key: DIN 6885-A 5 x 5 x 22
Must be ordered separately.

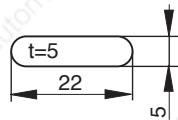

MB063-1ax/2

Fig 3.17: Dimensional data - MAC 063 - available options - (axial cooling)

3.7. Available Options

Type code fields		Example:	MAC 063 A-0-RS-4 - C/095-A-0/WI 520LV/S000	
1. Motor for analogue drives		MAC		
2. Motor size		063		
3. Motor length		A, B, C, D		
4. Type of cooling:				
natural convection		surface cooling		
0	axial		radial	
			blower right blower below blower left	
	AC 230 V 1 ¹⁾	AC 115 V 2 ¹⁾	AC 230 V 6 ³⁾ AC 115 V A ³⁾ AC 230 V 7 ³⁾ AC 115 V B ³⁾ AC 230 V 8 ³⁾ AC 115 V C ³⁾	
5. Type of windings				
Nominal rpm	Motor length			
	A	B	C	D
	3500 min ⁻¹	ES	GS	MS
6000 min ⁻¹	RS	JS	HS	FS
6. Motor feedback				
Motor type				
with tachofeedback			2	
with tachofeedback and second shaft end			3	
with tachofeedback and mounted incremental or absolute encoder			4	
Tacho voltage				
set to nominal motor speed: 1.5 V/1000 min ⁻¹			-	
Tacho type				
standard			C	
increased smooth run quality			F	
7. Centering diameter				
for design B05			095	
8. Power connection				
connector to side A			A	
connector to side B			B	
9. Blocking brake				
without blocking brake			0	
with standard blocking brake (3 Nm)			1	
Mounted encoder	10. Type ²⁾			
	Incremental encoder with standard mounting		WI	
	Absolute encoder		AM	
11. Encoder code ²⁾				
For available types, see section 2.4 "Motor feedback"				
12. Special types				
Fixed and documented by INDRAMAT with special number (see Drawing no.: 106-0105-4301-XX)				
Does not apply to standard motors.				

Fig 3.18: Type codes - MAC 063

3.8. Special options

Specification of Option	S001	S006	S007
with keyway per DIN 6885, sheet 1	X		X
output shaft with shaft sealing		X	X

Fig 3.19: Special options with a MAC 063

Empty page

4. MAC 071

4.1. Technical Data

Designation	Symbol	Unit	Motor type MAC ...		
			071 A - - - HS	071 B - - - FS	071 C - - - US
Nominal motor speed ¹⁾	n	min ⁻¹	2000	2000	2000
Continuous torque at standstill ²⁾	M _{dN}	Nm	2.2 (3.3) ⁵⁾	4.4 (6.6) ⁵⁾	6.6 (9.9) ⁵⁾
Continuous current at standstill	I _{dN}	A	2.6 (4.1) ⁵⁾	5.0 (7.9) ⁵⁾	7.3 (11.8) ⁵⁾
Rotor moment of inertia ³⁾	J _M	kgm ²	5.4 x 10 ⁻⁴	9.9 x 10 ⁻⁴	12.9 x 10 ⁻⁴
Torque constant at 20 °C	K _m	Nm/A	0.860	0.880	0.900
Windings resistance at 20 °C	R _A	Ohm	7.6	2.7	1.6
Windings inductance	L _A	mH	42	22	15
Maximum peak of pulse current	I _{peak}	A	13	25	37
Thermal time constant	T _{th}	min	45 (20) ⁵⁾	45 (20) ⁵⁾	45 (20) ⁵⁾
Mass ⁴⁾	m _M	kg	6.5	8.8	11
			071 A - - - OS	071 B - - - TS	071 C - - - NS
Nominal motor speed ¹⁾	n	min ⁻¹	3000	3000	3000
Continuous torque at standstill ²⁾	M _{dN}	Nm	2.2 (3.3) ⁵⁾	4.4 (6.6) ⁵⁾	6.6 (9.9) ⁵⁾
Continuous current at standstill	I _{dN}	A	3.8 (6.0) ⁵⁾	7.3 (11.7) ⁵⁾	11.0 (17.7) ⁵⁾
Rotor moment of inertia ³⁾	J _M	kgm ²	5.4 x 10 ⁻⁴	9.9 x 10 ⁻⁴	12.9 x 10 ⁻⁴
Torque constant at 20 °C	K _m	Nm/A	0.580	0.600	0.600
Windings resistance at 20 °C	R _A	Ohm	3.5	1.24	0.69
Windings inductance	L _A	mH	20	10	7
Maximum peak of pulse current	I _{peak}	A	19	37	55
Thermal time constant	T _{th}	min	45 (20) ⁵⁾	45 (20) ⁵⁾	45 (20) ⁵⁾
Mass ⁴⁾	m _M	kg	6.5	8.8	11
			071 A - - - ES	071 B - - - PS	071 C - - - JS
Nominal motor speed ¹⁾	n	min ⁻¹	4000	4000	4000
Continuous torque at standstill ²⁾	M _{dN}	Nm	2.2 (3.3) ⁵⁾	4.4 (6.6) ⁵⁾	6.6 (9.9) ⁵⁾
Continuous current at standstill	I _{dN}	A	5.0 (7.9) ⁵⁾	9.6 (15.3) ⁵⁾	15.3 (24.8) ⁵⁾
Rotor moment of inertia ³⁾	J _M	kgm ²	5.4 x 10 ⁻⁴	9.9 x 10 ⁻⁴	12.9 x 10 ⁻⁴
Torque constant at 20 °C	K _m	Nm/A	0.440	0.460	0.430
Windings resistance at 20 °C	R _A	Ohm	2.0	0.72	0.35
Windings inductance	L _A	mH	11	5.9	3.5
Maximum peak of pulse current	I _{peak}	A	25	48	77
Thermal time constant	T _{th}	min	45 (20) ⁵⁾	45 (20) ⁵⁾	45 (20) ⁵⁾
Mass ⁴⁾	m _M	kg	6.5	8.8	11
			071 A - - - VS	071 B - - - KS	071 C - - - GS
Nominal motor speed ¹⁾	n	min ⁻¹	6000	6000	6000
Continuous torque at standstill ²⁾	M _{dN}	Nm	2.2 (3.3) ⁵⁾	4.4 (6.6) ⁵⁾	6.6 (9.9) ⁵⁾
Continuous current at standstill	I _{dN}	A	7.3 (11.7) ⁵⁾	14.2 (22.3) ⁵⁾	22.0 (35.4) ⁵⁾
Rotor moment of inertia ³⁾	J _M	kgm ²	5.4 x 10 ⁻⁴	9.9 x 10 ⁻⁴	12.9 x 10 ⁻⁴
Torque constant at 20 °C	K _m	Nm/A	0.300	0.310	0.300
Windings resistance at 20 °C	R _A	Ohm	0.92	0.34	0.17
Windings inductance	L _A	mH	5.1	2.8	1.7
Maximum peak of pulse current	I _{peak}	A	37	71	110
Thermal time constant	T _{th}	min	45 (20) ⁵⁾	45 (20) ⁵⁾	45 (20) ⁵⁾
Mass ⁴⁾	m _M	kg	6.5	8.8	11

¹⁾ The usable motor speed is determined by the drive used.
 Only those usable speeds n_{max} found in the selection lists of the motor-drive combinations are binding.
²⁾ With 60K overtemperature at the motor housing.
 Continuous torque can be limited by the drive. See selection data.
³⁾ With tacho-generator, without holding brake
⁴⁾ With tacho-generator, without holding brake, without blower.
⁵⁾ Parenthetical values apply to versions with surface cooling.

Fig 4.1: Type-dependent motor data

Designation	Symbol	Unit	Data	
Permissible ambient temperature	T_{um}	°C	0 ... + 45	
Permissible storage and transport temperature	T_L	°C	-20 ... +80	
Maximum installation elevation		m	1000 meters above sea level	
Protection category			IP 65	
Insulation classification			F	
Housing coat			Black prime coat (RAL 9005)	
Voltage constant of the tachogenerator ¹⁾	C_w	Vs/rad V/min ⁻¹	0,0143 1.5/1000	0.0286 3/1000

¹⁾ Tacho voltage can be selected application-related.

Fig 4.2: General data MAC 071

Designation	Symbol	Unit	Data holding brake	
			Standard	heavy-duty
Principle of action				electrically-actuated release
Holding torque	M_H	Nm	3.0	6.5
Nominal voltage	U_N	V		DC 24 ± 10%
Nominal current	I_N	A	0.6	0.7
Moment of inertia	J_B	kgm ²	0.38 x 10 ⁻⁴	1.06 x 10 ⁻⁴
Release delay	t_L	ms	30	60
Clamping delay	t_K	ms	15	20
Mass	m_B	kg	0.3	0.5

Fig 4.3: Technical data - holding brake

Designation	Symbol	Unit	Axial cooling	Radial cooling
Power consumption	S_N	VA	22/22	22/22
Nominal voltage	U_N	V	AC 230 or 115 ¹⁾	AC 230 or 115 ¹⁾
Frequency	f	Hz	50/60	50/60
Mass	m_L	kg	approx. 0.8 ²⁾	approx. 0.7 ²⁾
Protection category blower unit			IP 24	IP 24
Protection category blower motor			IP 44	IP 44

¹⁾ 115 V special design
²⁾ Blower shroud for motor with tacho feedback.

Fig 4.4: Technical data - surface cooling

4.2. Torque-Speed Characteristics

MAC 071 A - - - HS
2000 min⁻¹

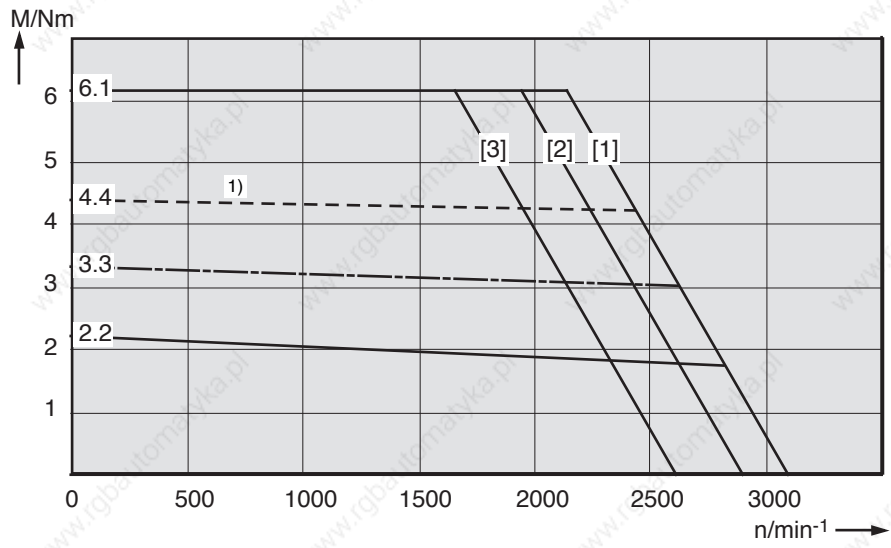

MAC 071 A - - - OS
3000 min⁻¹

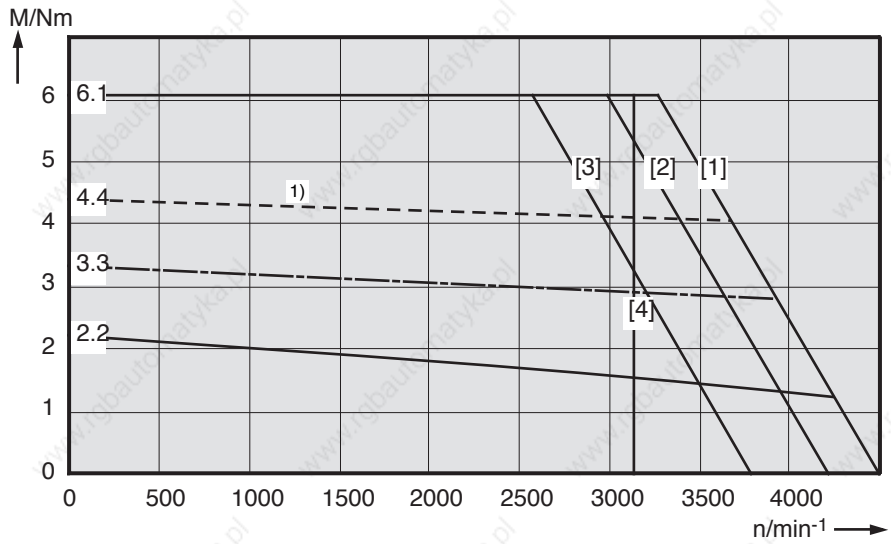

¹⁾ shown: ON time of surface-cooled motor 56%

Fig 4.5: Torque-speed characteristics MAC 071

MAC 071 A - - - ES
4000 min⁻¹

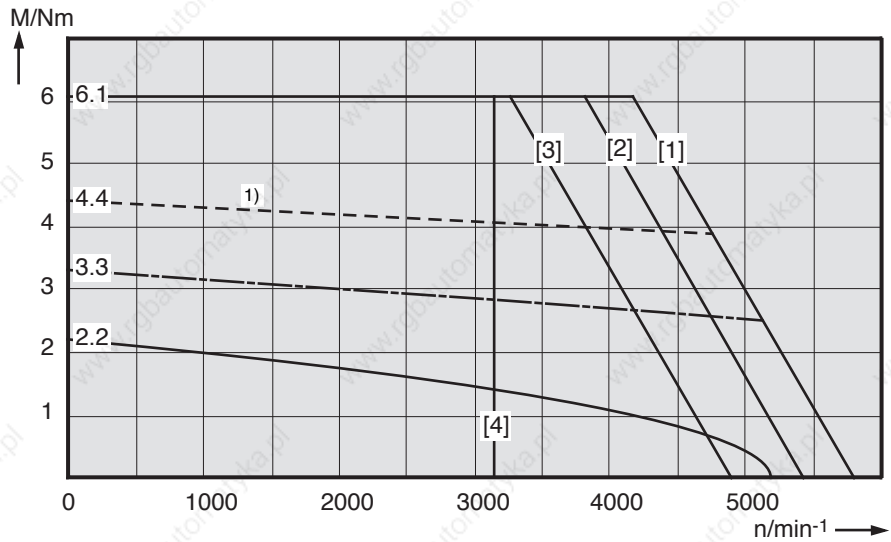

MAC 071 A - - - VS
6000 min⁻¹

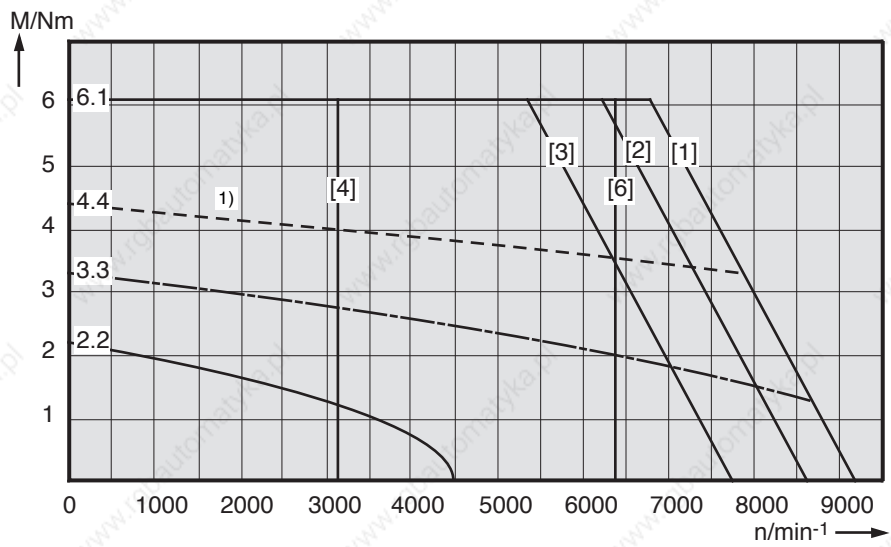

1) shown: ON time of surface-cooled motor 56%

Fig 4.6: Torque-speed characteristics MAC 071

MAC 071 B - • - FS
2000 min⁻¹

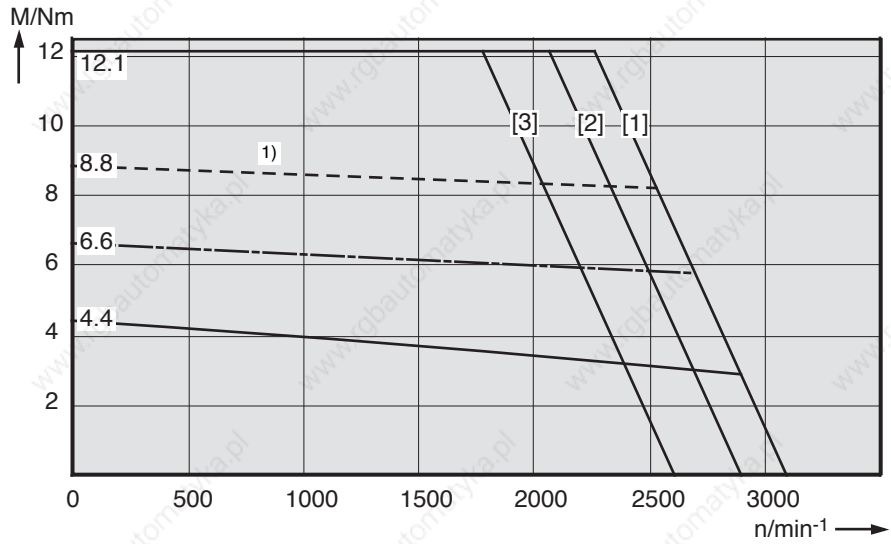

MAC 071 B - • - TS
3000 min⁻¹

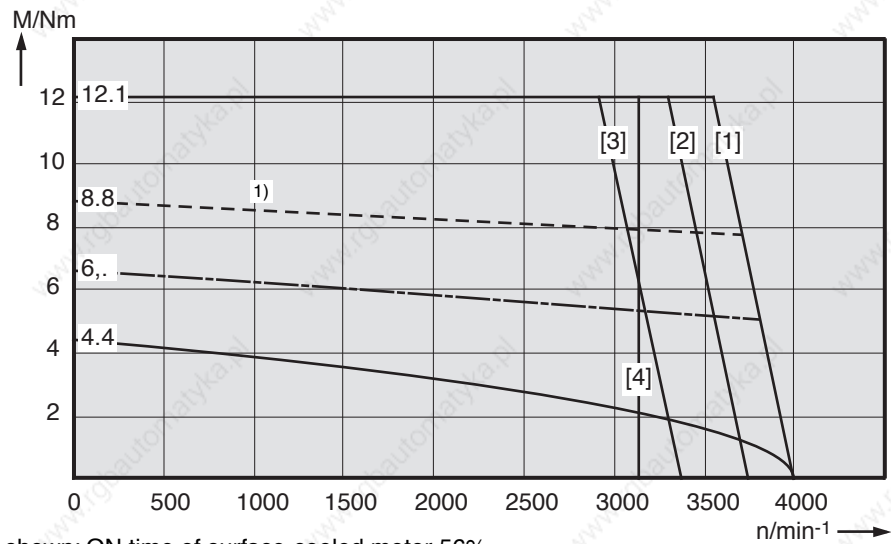
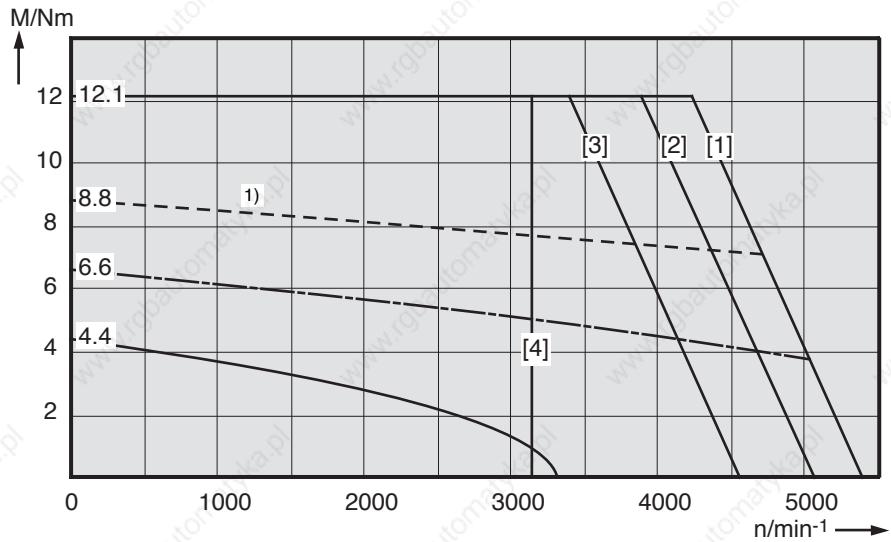
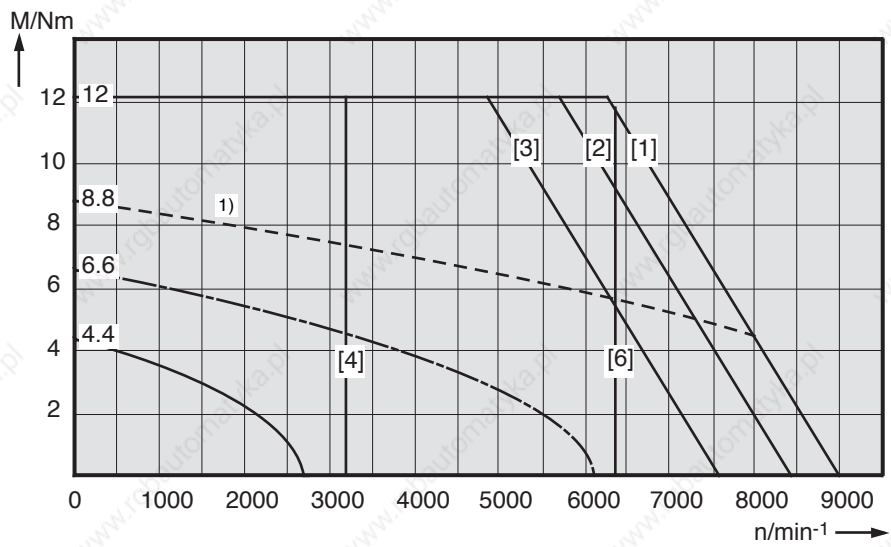

Fig 4.7: Torque-speed characteristics MAC 071

MAC 071 B - - - PS
4000 min⁻¹



MAC 071 B - - - KS
6000 min⁻¹



1) shown: ON time of surface-cooled motor 56%

Fig 4.8: Torque-speed characteristics MAC 071

MAC 071 C - - - US
2000 min⁻¹

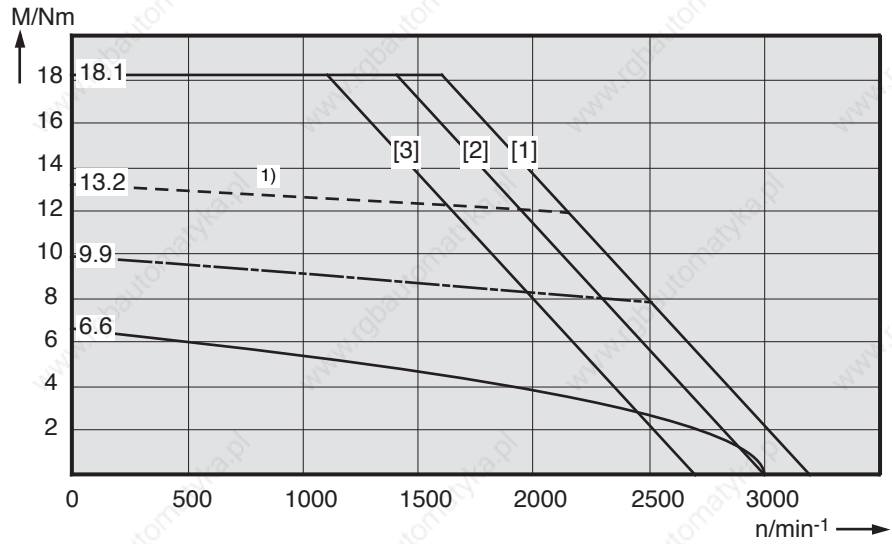

MAC 071 C - - - NS
3000 min⁻¹

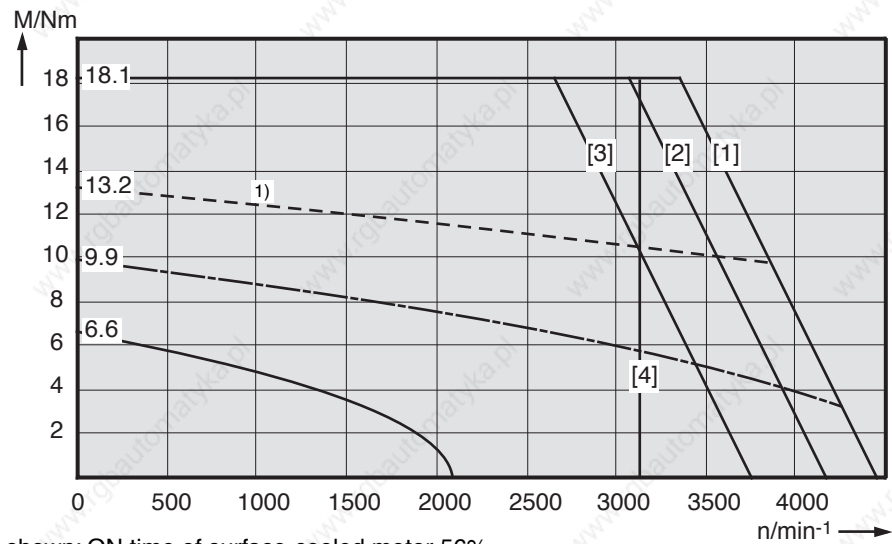

¹⁾ shown: ON time of surface-cooled motor 56%

Fig 4.9: Torque-speed characteristics MAC 071

MAC 071 C - - - JS
4000 min⁻¹

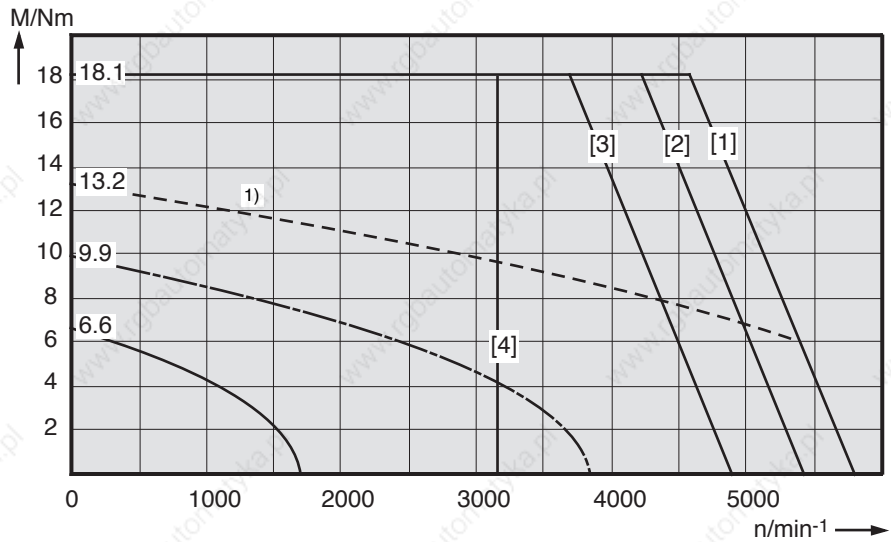

MAC 071 C - - - GS
6000 min⁻¹

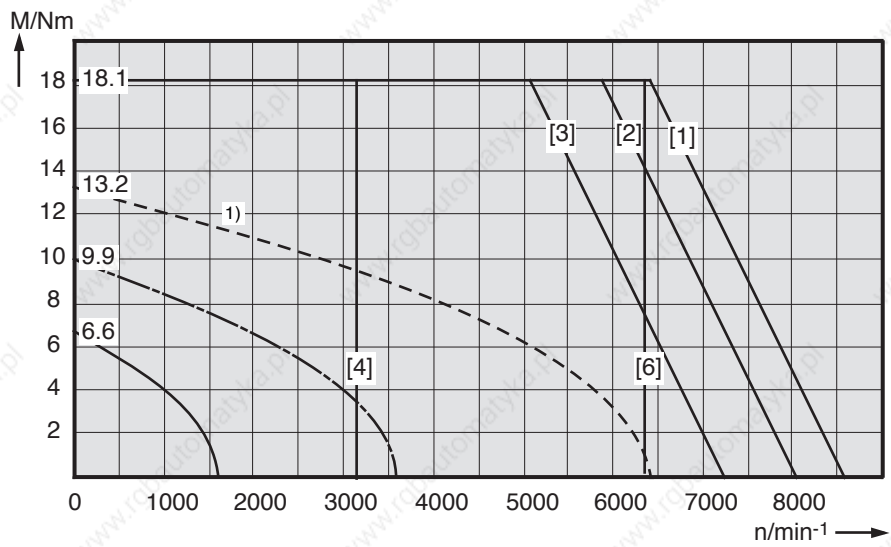

1) shown: ON time of surface-cooled motor 56%

Fig 4.10: Torque-speed characteristics characteristics MAC 071

4.3. Shaft Load Capacity

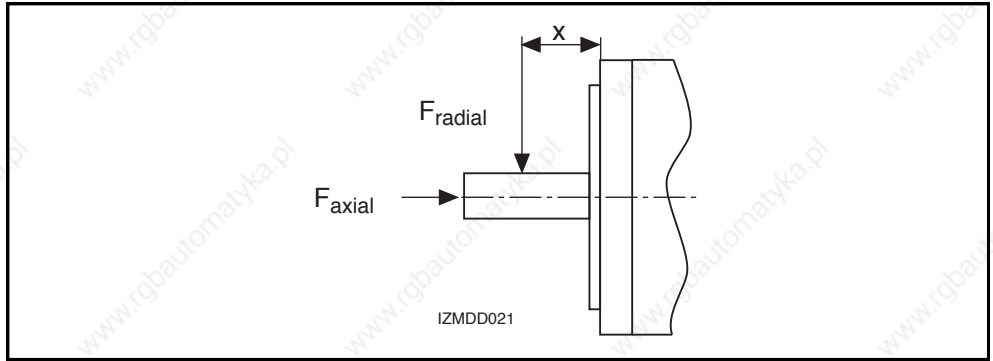

Fig 4.11: Shaft load

Permissible radial force

F_{radial}

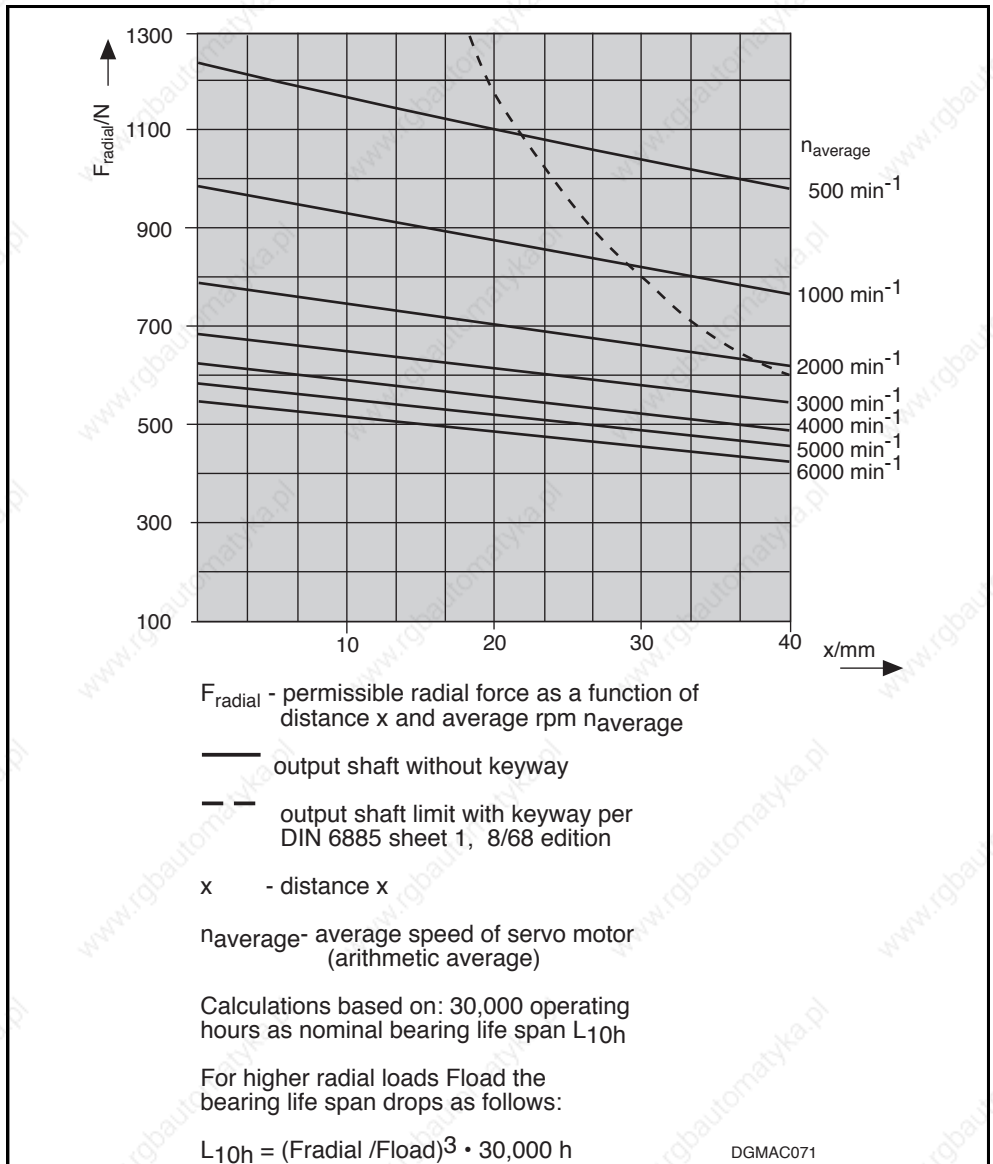

Fig 4.12: Permissible radial force

Permissible axial force

F_{axial}

$$F_{axial} = 0.50 \cdot F_{radial}$$

F_{axial} - Permissible axial force

F_{radial} - Permissible radial force

4.4. Dimensional Data - Natural Convection

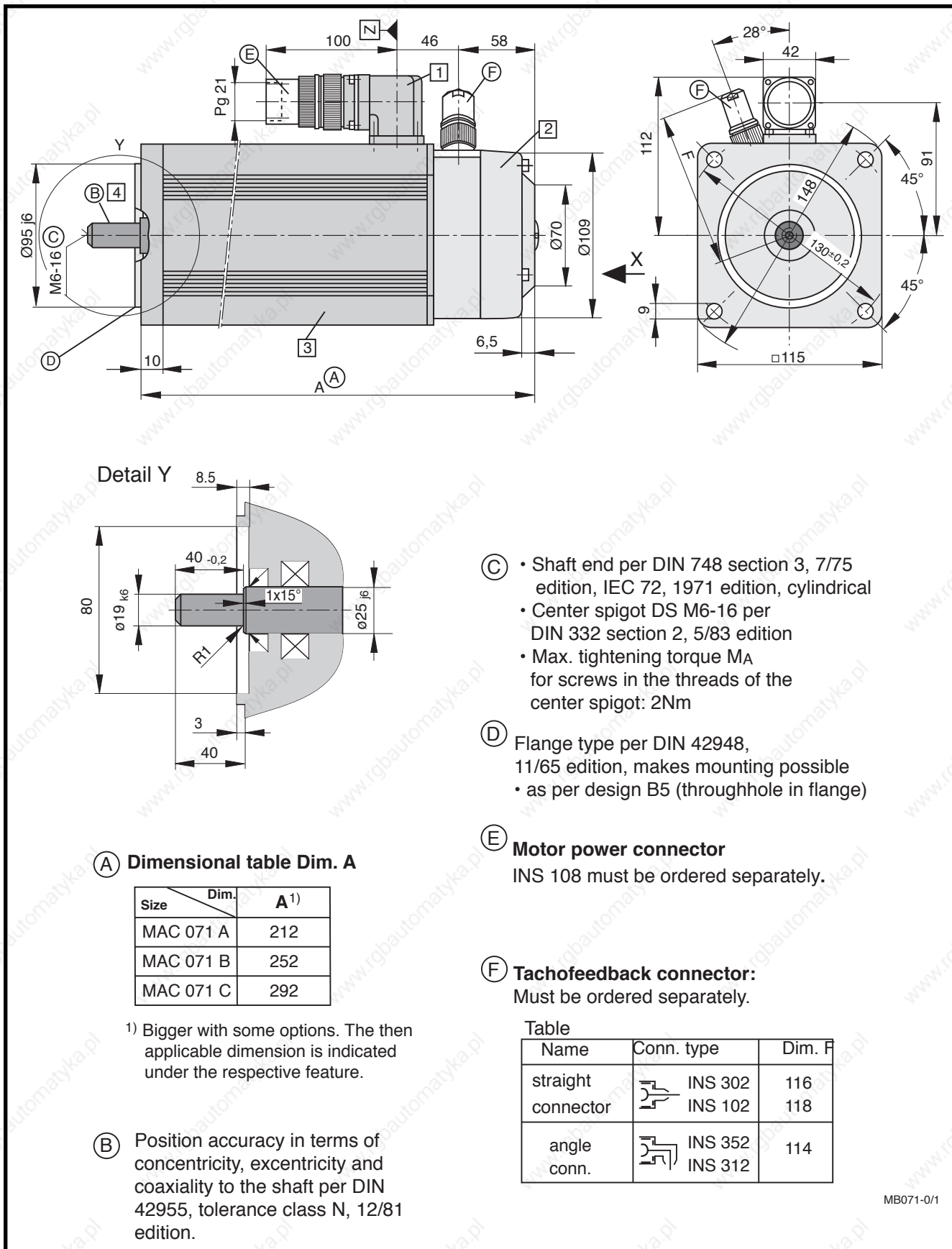

Fig 4.13: Dimensional data - MAC 071 (natural convection)

Available options

1 Power connection

The output direction of the electrical power connector is selected at the time the order is placed. Possible output directions are:

- to side A
- to side B
- to the right
- to the left

The drawing depicts side A as output direction. The dimensions of any other direction are obtained by a virtual turning of the connector housing around the Z axis.

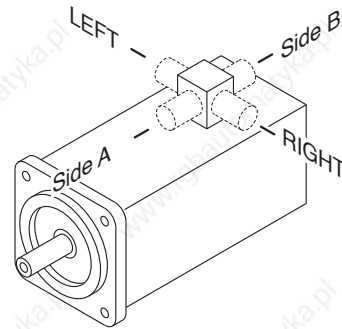

2 Motor version

- Tachofeedback and second shaft end

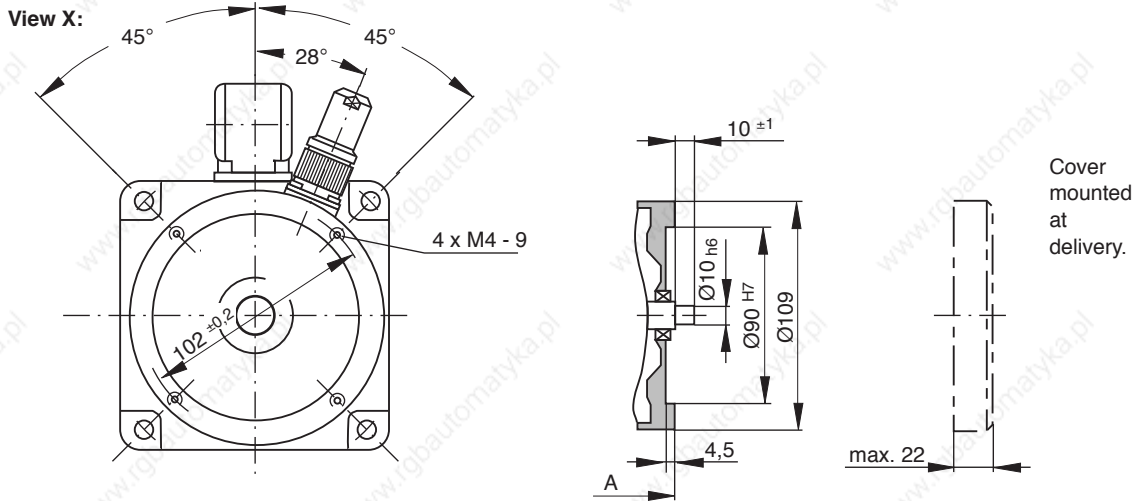

- Tachofeedback and mounted incremental encoder

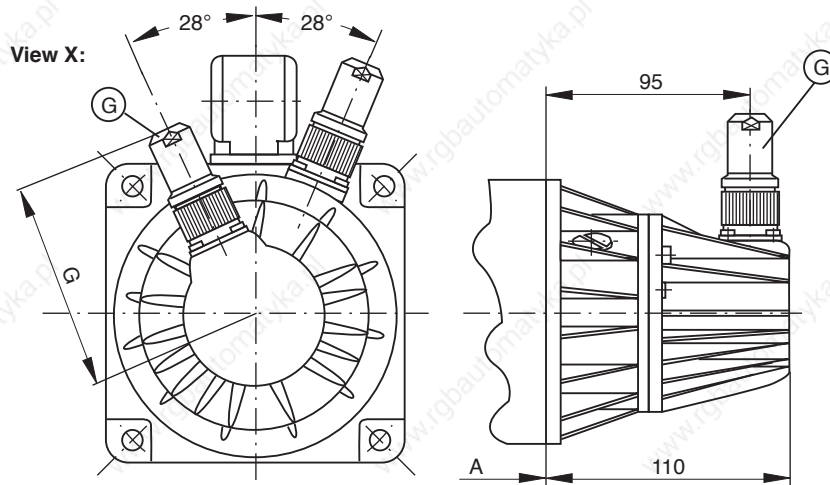

Incremental encoder connector
Must be ordered separately.

Name	Conn. type	Dim. G
straight conn.	INS 301	88
	INS 101	90
angle conn.	INS 351	86
	INS 311	

- Tachofeedback and mounted absolute encoder (see following page)

MB071-0/2

Fig 4.14: Dimensional data - MAC 071 - available options - (natural convection)

Available options

- Tachofeedback and mounted absolute encoder

View X:

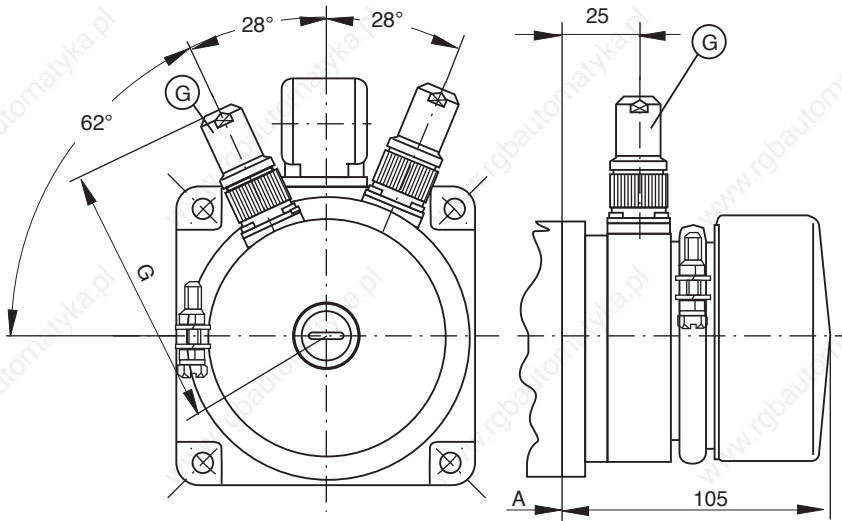

G Absolute encoder conn.
Must be ordered separately.

Name	Conn. type	Dim. G
straight conn.	INS 326	104
	INS 92	
angle conn.	INS 322	102

3 Blocking brake

- without blocking brake
Dim. A retained
- Standard blocking brake: 3 Nm
Dim. A retained
- heavy-duty blocking brake: 6.5 Nm

Table for blocking brake with 6.5Nm holding torque

Size	Dim.	A
MAC 071 A		240
MAC 071 B		280
MAC 071 C		320

4 Output shaft

- plain shaft (recommended type)
- with keyway per DIN 6885 sh. 1, 8/68 edition
(Note! balanced with entire key.)

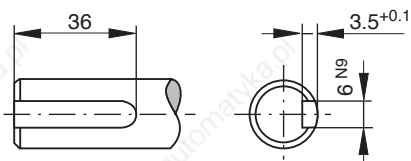

Matching key: DIN 6885-A 6 x 6 x 36
Must be ordered separately.

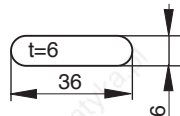

MB071-0/3

Fig 4.15: Dimensional data - MAC 071 - available options - (natural convection)

4.5. Dimensional Data - Radial Cooling

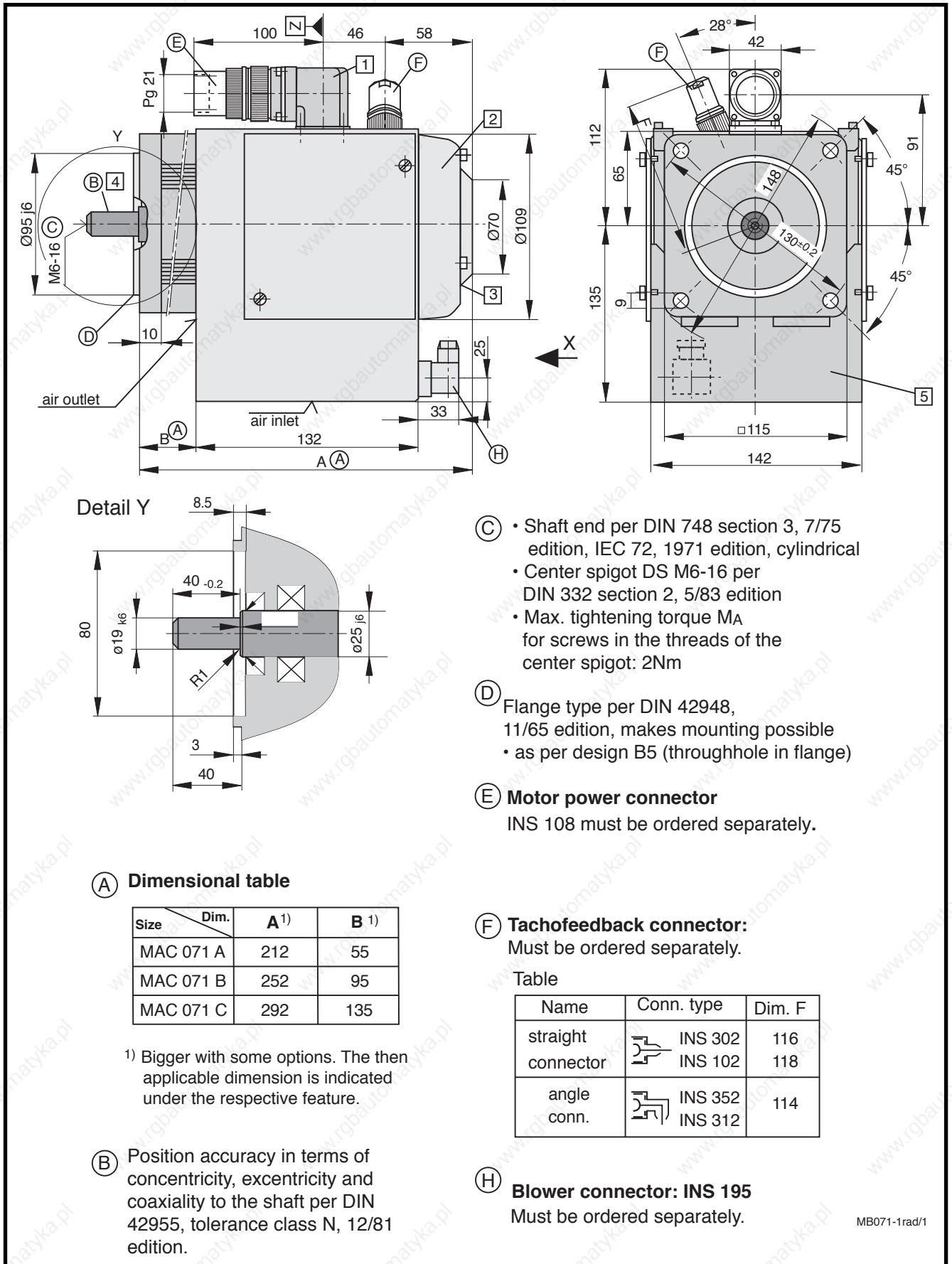

Fig 4.16: Dimensional data - MAC 071 (radial cooling)

MB071-1rad/1

Available options

1 Power connection

The output direction of the electrical power connector is selected at the time the order is placed. Possible output directions are:

- to side A
- to side B
- to the right
- to the left

The drawing depicts side A as output direction. The dimensions of any other direction are obtained by a virtual turning of the connector housing around the Z axis.

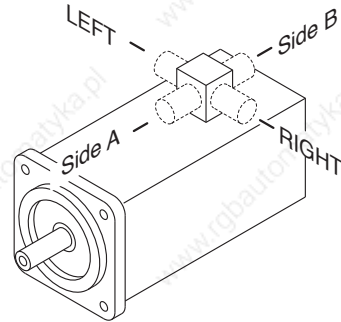

2 Motor version

- Tachofeedback and second shaft end

View X:

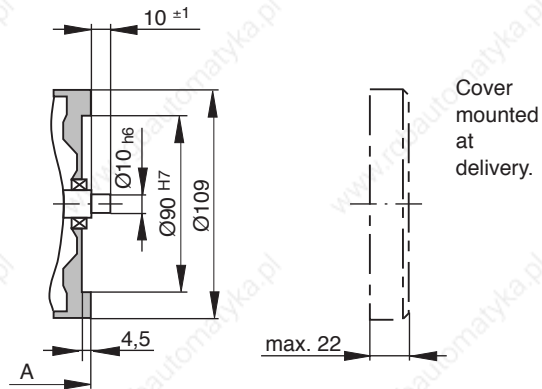
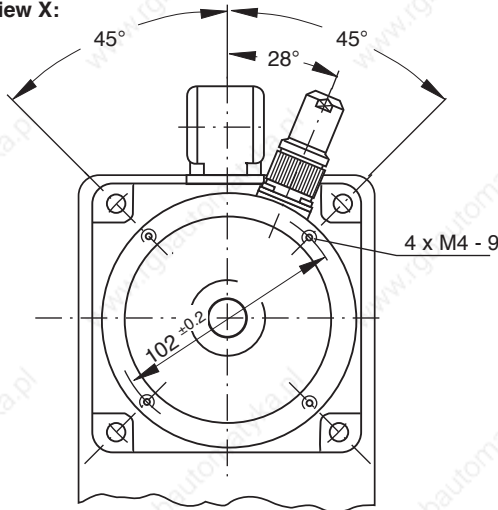

- Tachofeedback and mounted incremental encoder

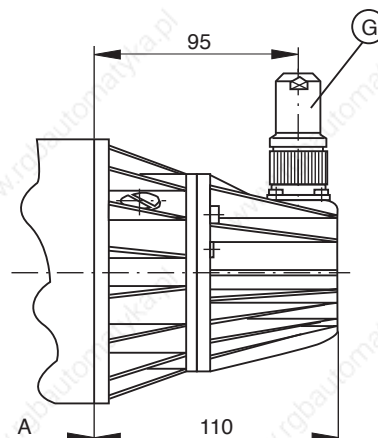
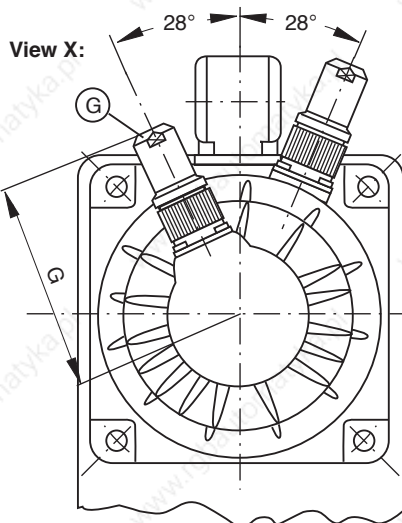

G Incremental encoder connector

Must be ordered separately.

Name	Conn. type	Dim. G
straight conn.	INS 301	88
	INS 101	90
angle conn.	INS 351 INS 311	86

- Tachofeedback and mounted absolute encoder (see following page)

MB071-1rad/2

Fig 4.17: Dimensional data - MAC 071 - available options - (radial cooling)

Available options

- Tachofeedback and mounted absolute encoder

View X:

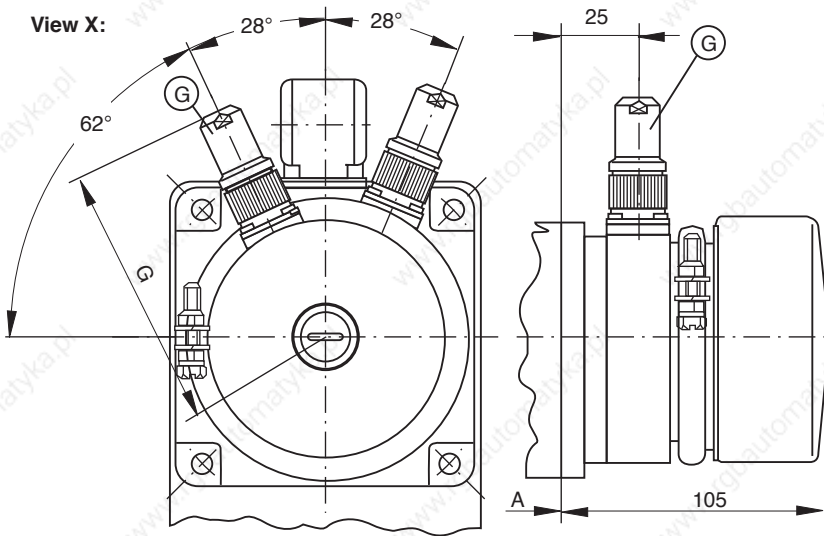

G Absolute encoder conn.
Must be ordered separately.

Name	Conn. type	Dim. G
straight conn.	INS 326	104
	INS 92	
angle conn.	INS 322	102

3 Blocking brake

- without blocking brake
Dim. A and B retained
- Standard blocking brake: 3 Nm
Dim. A and B retained
- heavy-duty blocking brake: 6.5 Nm

Table for blocking brake with 6.5 Nm holding torque

Size \ Dim.	A	B
MAC 071 A	240	83
MAC 071 B	280	123
MAC 071 C	320	163

4 Output shaft

- plain shaft (recommended type)
- with keyway per DIN 6885 sh. 1, 8/68 edition
(Note! balanced with entire key.)

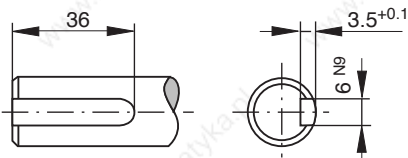

Matching key: DIN 6885-A 5 x 5 x 22
Must be ordered separately.

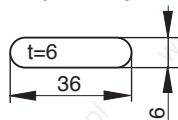

5 Blower arrangement

Looking towards motor shaft.

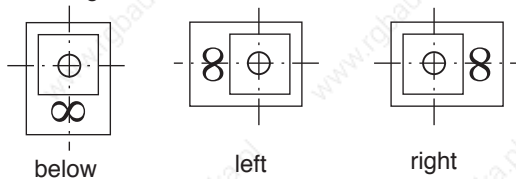

MB071-1rad/3

Fig 4.18: Dimensional data - MAC 071 - available options - (radial cooling)

4.6. Dimensional Data - Axial Cooling

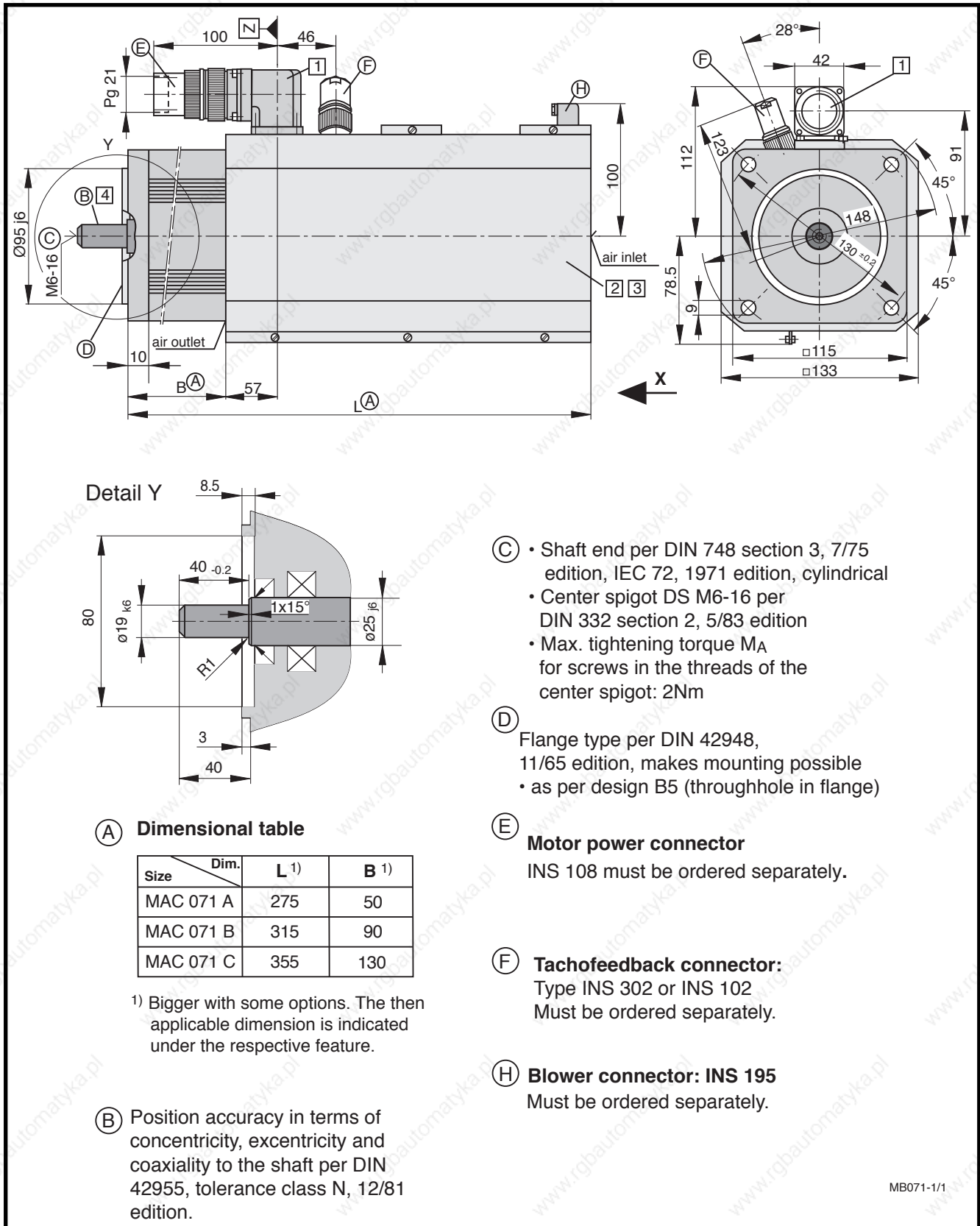

Fig 4.19: Dimensional data - MAC 071 (axial cooling)

Available options

1 Power connection

The output direction of the electrical power connector is selected at the time the order is placed. Possible output directions are:

- to side A
- to side B
- to the right
- to the left

The drawing depicts side A as output direction. The dimensions of any other direction are obtained by a virtual turning of the connector housing around the Z axis.

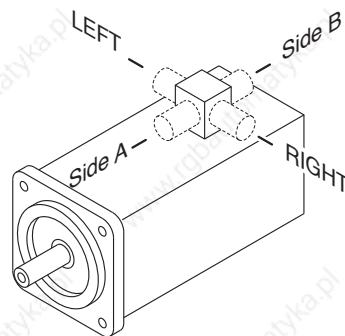

2 Motor version

- Tachofeedback and mounted incremental encoder

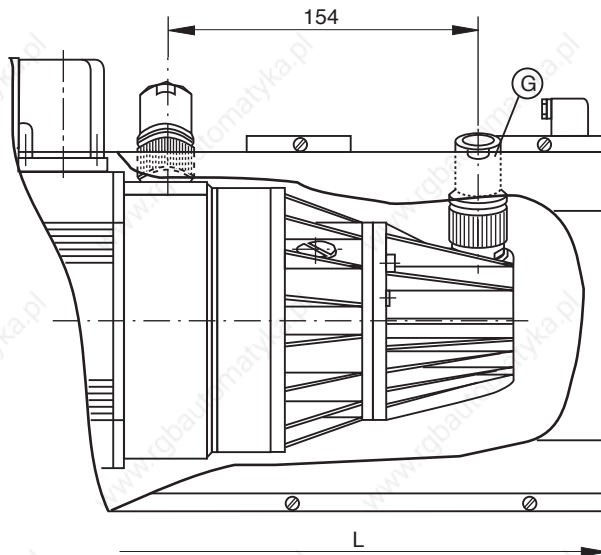
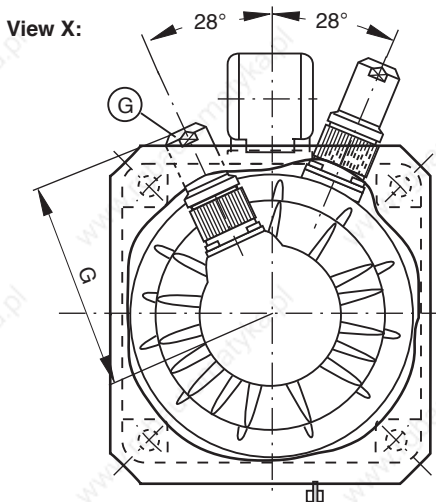

G Incremental encoder connector

Must be ordered separately.

Name	Conn. type	Dim. G
straight	INS 302	88
conn.	INS 102	90

Table:

Size	Dim.	L	B
MAC 071 A		395	78
MAC 071 B		435	118
MAC 071 C		475	158

- Tachofeedback and mounted absolute encoder (see following page)

MB071-1/2

Fig 4.20: Dimensional data - MAC 071 -available options - (axial cooling)

Available options

- Tachofeedback and mounted absolute encoder

View X:

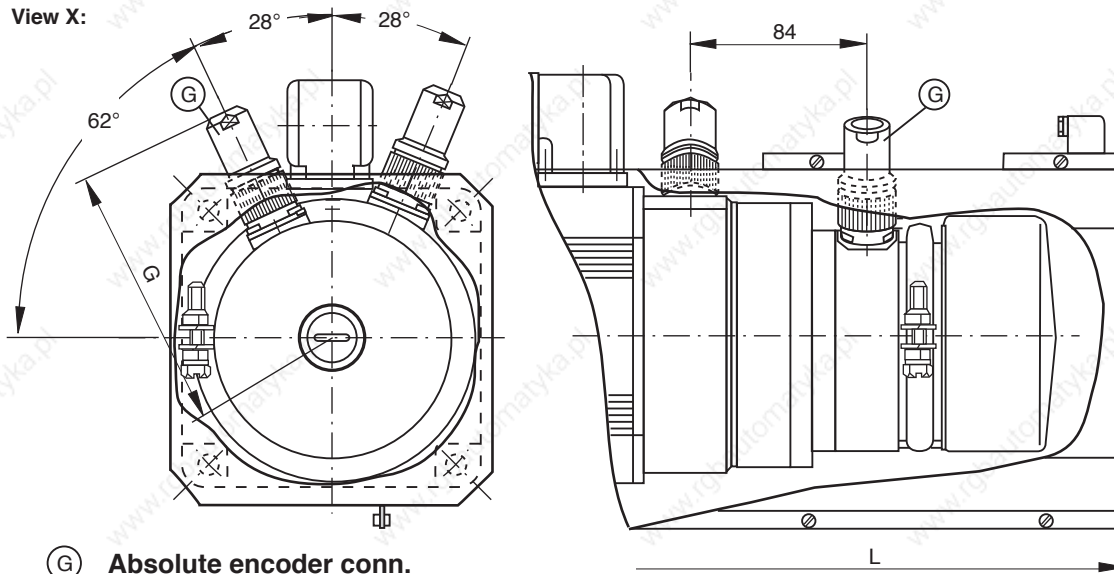

G Absolute encoder conn.
Must be ordered separately.

Name	Conn. type	Dim. G
straight conn.	INS 326 INS 92	104 106

Table

Size	Dim.	L	B
MAC 071 A		395	78
MAC 071 B		435	118
MAC 071 C		475	158

3 Blocking brake

- without blocking brake
Dim. L and B retained
- Standard blocking brake: 3 Nm
Dim. L and B retained
- heavy-duty blocking brake: 6.5 Nm

Table for blocking brake
with 6.5Nm holding torque

Size	Dim.	Vers. 2		Vers. 4	
		L	B	L	B
MAC 071 A		303	78	423	106
MAC 071 B		343	118	463	146
MAC 071 C		383	158	503	186

Vers. 2 =
Motor with tachofeedback

Vers. 4 =
Motor with tachofeedback and
mounted encoder

4 Output shaft

- plain shaft (recommended type)
- with keyway per DIN 6885 sh. 1, 8/68 edition
(Note! balanced with entire key.)

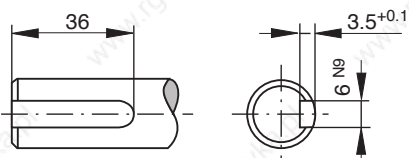

Matching key: DIN 6885-A 5 x 5 x 22
Must be ordered separately.

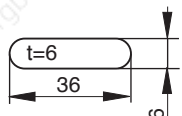

MB071-1/3

Fig 4.21: Dimensional data - MAC 071 - available options - (axial cooling)

4.7. Available Options

Type code fields		Example:	MAC 071 A-0-ES-4 - C/095-A-0/WI 520LV/S000							
1. Motor for analogue drives		MAC								
2. Motor size		071								
3. Motor length		A, B, C								
4. Type of cooling:										
natural convection			surface cooling							
			axial				radial			
					blower right		blower below		blower left	
			AC 230 V	AC 115 V	AC 230 V	AC 115 V	AC 230 V	AC 115 V	AC 230 V	AC 115 V
0			1 ¹⁾	2 ¹⁾	6	A	7	B	8	C
5. Type of windings										
Nominal rpm	Motor length		A		B		C			
2000 min ⁻¹	HS		FS		US					
3000 min ⁻¹	OS		TS		NS					
4000 min ⁻¹	ES		PS		JS					
6000 min ⁻¹	VS		KS		GS					
6. Motor feedback										
Motor type										
with tachofeedback		2								
with tachofeedback and second shaft end		3								
with tachofeedback and mounted incremental or absolute encoder		4								
Tacho voltage										
set to nominal motor speed		-								
(nominal rpm > 3000 min ⁻¹ : 1.5 V/1000 min ⁻¹)										
(nominal rpm ≤ 3000 min ⁻¹ : 3 V/1000 min ⁻¹)										
1.5 V/1000 min ⁻¹		H								
Tacho type										
Standard		C								
increased smooth run quality		F								
7. Centering diameter										
for design B05 and B14		095								
8. Power connection										
connector to side A		A								
connector to side B		B								
connector to right (looking onto output shaft)		R								
connector to left (looking onto output shaft)		L								
9. Blocking brake										
without blocking brake		0								
with standard blocking brake (3 Nm)		1								
with heavy-duty blocking brake (6.5 Nm)		2								
Mounted encoder	10. Type ²⁾									
	Incremental encoder with standard mounting	WI								
	Incremental encoder with shock-damped mounting	DI								
	Absolute encoder	AM								
	11. Encoder code ²⁾									
	For available types, see section 2.4 "Motor feedback"									
12. Special types										
Fixed and documented by INDRAMAT with special number (see Drawing no.: 106-0105-4301-XX)										
Does not apply to standard motors.										

Fig 4.22: Type codes MAC 071

TLMAC071

4.8. Special Options

Specification of Option	S001
with keyway per DIN 6885, sheet 1	X

Fig 4.23: Special options with a MAC 071

Empty page

5. MAC 090

5.1. Technical Data

Designation	Symbol	Unit	Motor type MAC ...			
			090 A - - - Z •	090 B - - - P •	090 C - - - K •	090 C - - - ED
Nominal motor speed ¹⁾	n	min ⁻¹	2000	2000	2000	5000
Continuous torque at standstill ²⁾	M _{dN}	Nm	3.7 (5.0) ⁵⁾	7.2 (10.5) ⁵⁾	10.4 (16.0) ⁵⁾	10.0 (16.0) ⁵⁾
Continuous current at standstill	I _{dN}	A	8.1(10.9) ⁵⁾	11.9 (17.4) ⁵⁾	17.0 (26.1) ⁵⁾	35.0 (52.0) ⁵⁾
Rotor moment of inertia ³⁾	J _M	kgm ²	20 x 10 ⁻⁴	36 x 10 ⁻⁴	53 x 10 ⁻⁴	53 x 10 ⁻⁴
Torque constant at 20 °C	K _m	Nm/A	0.51	0.67	0.68	0.31
Windings resistance at 20 °C	R _A	Ohm	1.85	0.97	0.60	0.12
Windings inductance	L _A	mH	1.9	5.1	3.6	0.8
Maximum peak of pulse current	I _{peak}	A	53	86	125	270
Thermal time constant	T _{th}	min	45 (30) ⁵⁾	60 (45) ⁵⁾	60 (45) ⁵⁾	60 (45) ⁵⁾
Mass ⁴⁾	m _M	kg	12.5	18	23	23
			090 A - - - R •	090 B - - - N •	090 B - - - J •	090 C - - - G •
Nominal motor speed ¹⁾	n	min ⁻¹	3000	3000	3000	3000
Continuous torque at standstill ²⁾	M _{dN}	Nm	3.5 (5.0) ⁵⁾	6.7 (10.5) ⁵⁾	6.7 (10.5) ⁵⁾	9.6 (16.0) ⁵⁾
Continuous current at standstill	I _{dN}	A	11.4 (16.3) ⁵⁾	13.0 (20.0) ⁵⁾	18.2 (28.5) ⁵⁾	24.8 (41.3) ⁵⁾
Rotor moment of inertia ³⁾	J _M	kgm ²	20 x 10 ⁻⁴	36 x 10 ⁻⁴	36 x 10 ⁻⁴	53 x 10 ⁻⁴
Torque constant at 20 °C	K _m	Nm/A	0.34	0.58	0.41	0.43
Windings resistance at 20 °C	R _A	Ohm	0.56	0.75	0.38	0.24
Windings inductance	L _A	mH	3.2	3.9	2.0	1.5
Maximum peak of pulse current	I _{peak}	A	76	98	137	196
Thermal time constant	T _{th}	min	45 (30) ⁵⁾	60 (45) ⁵⁾	60 (45) ⁵⁾	60 (45) ⁵⁾
Mass ⁴⁾	m _M	kg	12.5	18	18	23

¹⁾ The usable motor speed is determined by the drive used.
 Only those usable speeds n_{max} found in the selection lists of the motor-drive combinations are binding.
²⁾ With 60K overtemperature at the motor housing.
 Continuous torque can be limited by the drive. See selection data.
³⁾ With tacho-generator, without holding brake
⁴⁾ With tacho-generator, without holding brake, without blower.
⁵⁾ Parenthetical values apply to versions with surface cooling.

Fig 5.1: Type-dependent motor data

Designation	Symbol	Unit	Data		
Permissible ambient temperature	T _{um}	°C	0 ... + 45		
Permissible storage and transport temperature	T _L	°C	-20 ... +80		
Maximum installation elevation		m	1000 m. above sea level		
Protection category			IP 65		
Insulation classification			F		
Housing coat			Black prime coat (RAL 9005)		
Voltage constant of the tachogenerator ¹⁾	C _w	Vs/rad V/min ⁻¹	0.0143 1.5/1000	0.0286 3/1000	0.0572 6/1000 ²⁾

¹⁾ Tachovoltage can be selected application-related.
²⁾ If the 6 V/1000 min⁻¹ tachometer is used, then the maximum usable speed is limited to 1600 min⁻¹.

Fig 5.2: General data MAC 090

Designation	Symbol	Unit	Data holding brake	
			Standard	heavy-duty
Principle of action				electrically-actuated release
Holding torque	M_H	Nm	6.5	14
Nominal voltage	U_N	V		DC 24 ± 10%
Nominal current	I_N	A	0.7	0.7
Moment of inertia	J_B	kgm ²	1.06×10^{-4}	3.6×10^{-4}
Release delay	t_L	ms	60	70
Clamping delay	t_K	ms	20	30
Mass	m_B	kg	0.5	0.5

Fig 5.3: Technical data - holding brake

Designation	Symbol	Unit	Data surface cooling	
			Axial cooling	Radial cooling
Power consumption	S_N	VA	40/42	40/42
Nominal voltage	U_N	V	AC 230 or 115 ¹⁾	AC 230 or 115 ¹⁾
Frequency	f	Hz	50/60	50/60
Mass	m_L	kg	approx. 3.3 ²⁾	approx. 3.2 ²⁾
Protection category blower unit			IP 24	IP 24
Protection category blower motor			IP 44	IP 44

¹⁾ 115 V special design
²⁾ Blower shroud for motor with tacho feedback.

Fig 5.4: Technical data - surface cooling

5.2. Torque-Speed Characteristics

MAC 090 A - - - Z •
2000 min⁻¹

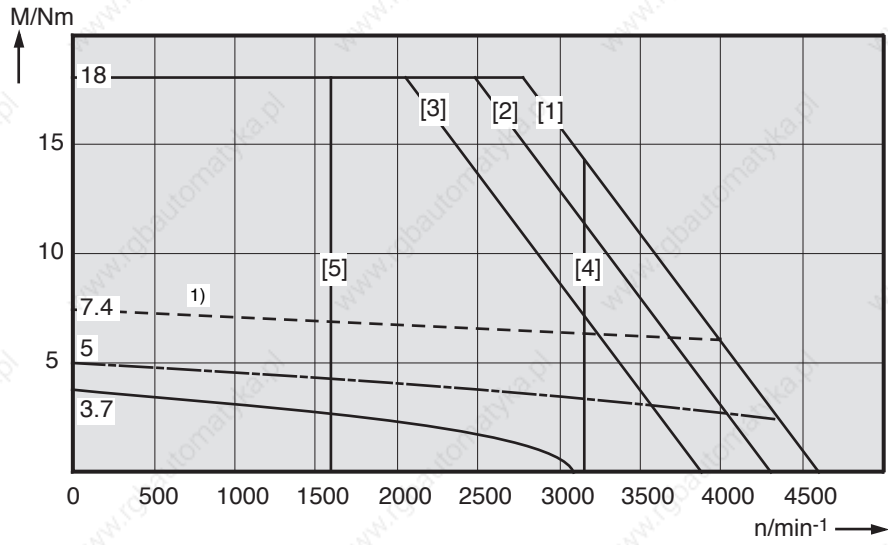

MAC 090 A - - - R •
3000 min⁻¹

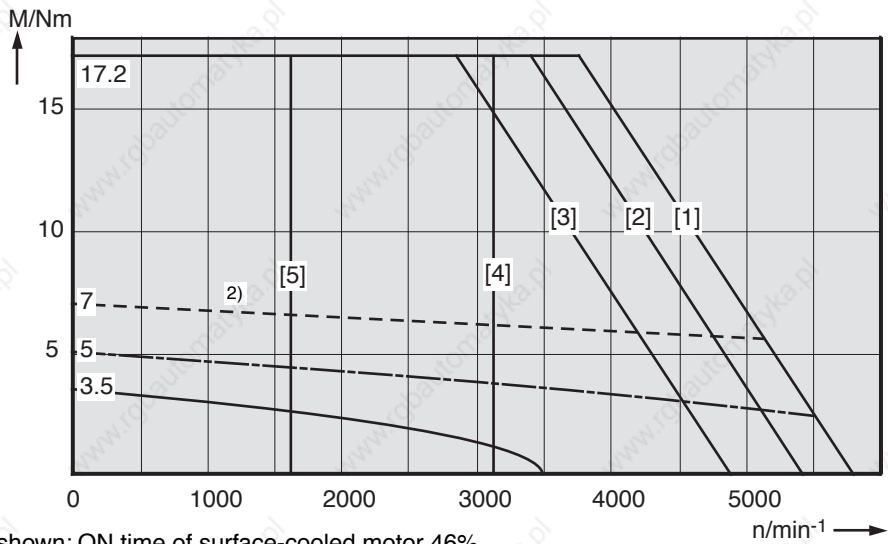

1) shown: ON time of surface-cooled motor 46%
2) shown: ON time of surface-cooled motor 51%

Fig 5.5: Torque-speed characteristics MAC 090

MAC 090 B - - - P •
2000 min⁻¹

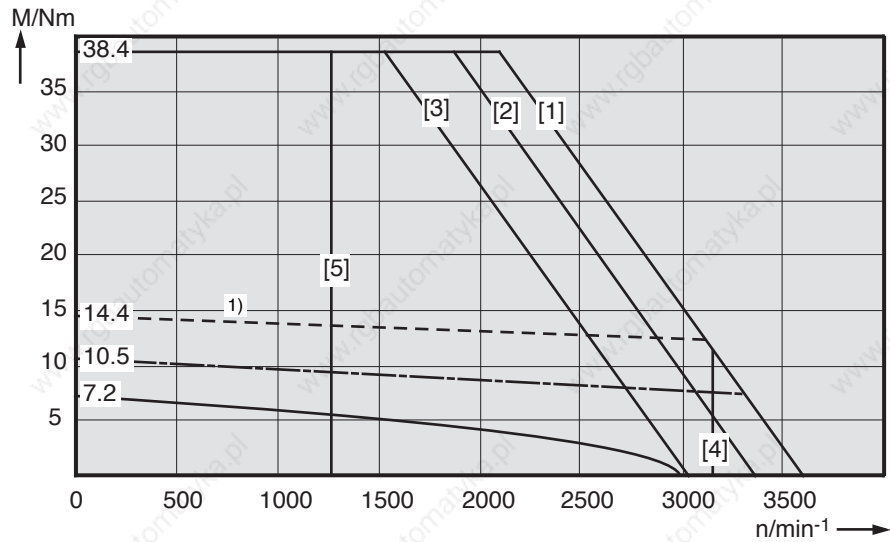

MAC 090 B - - - N •
3000 min⁻¹

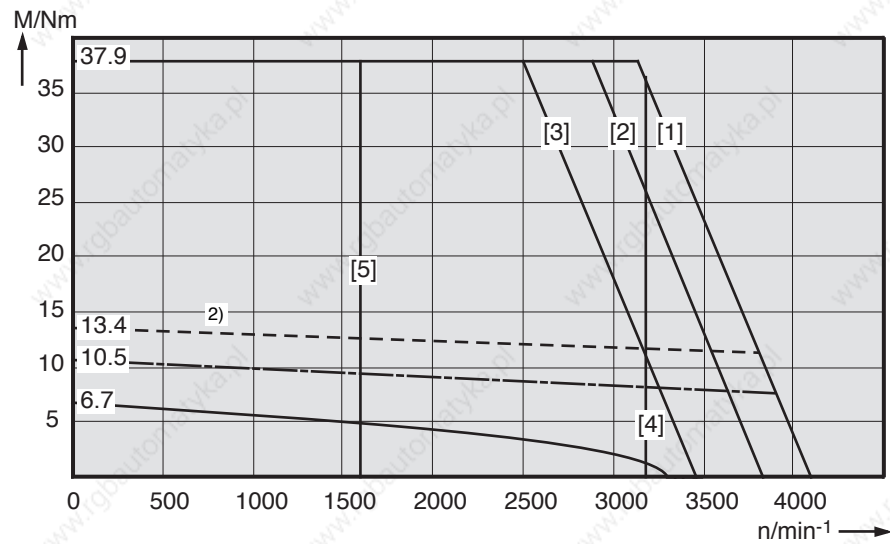

MAC 090 B - - - J •
3000 min⁻¹

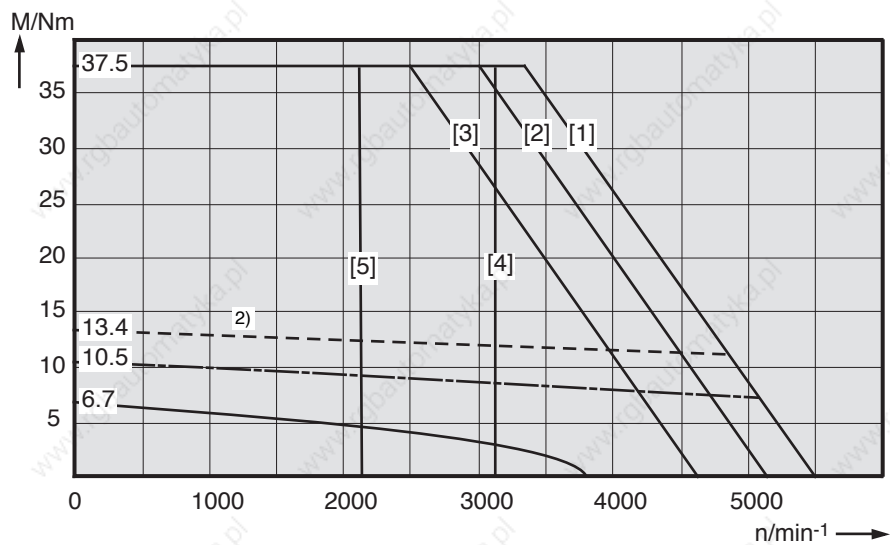

1) shown: ON time of surface-cooled motor 53%
2) shown: ON time of surface-cooled motor 61%

Fig 5.6: Torque-speed characteristics MAC 090

MAC 090 C - - - K •
2000 min⁻¹

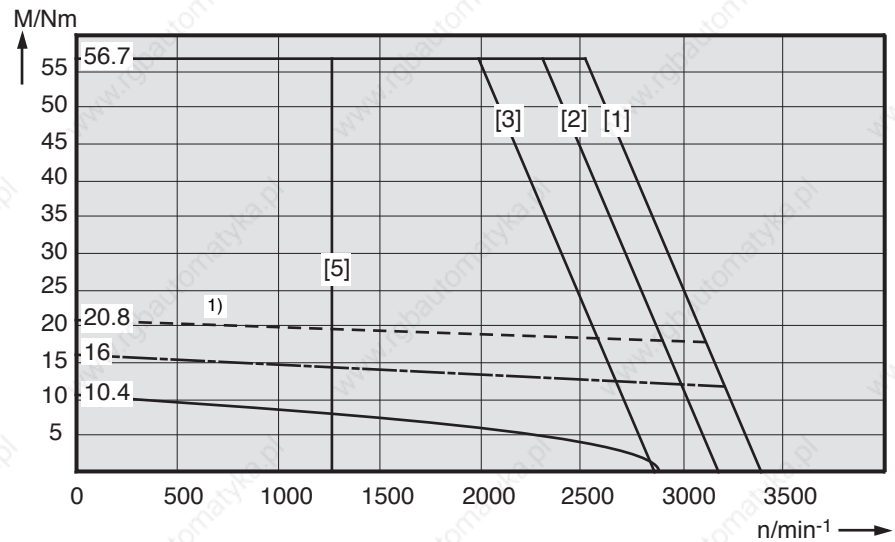

MAC 090 C - - - G •
3000 min⁻¹

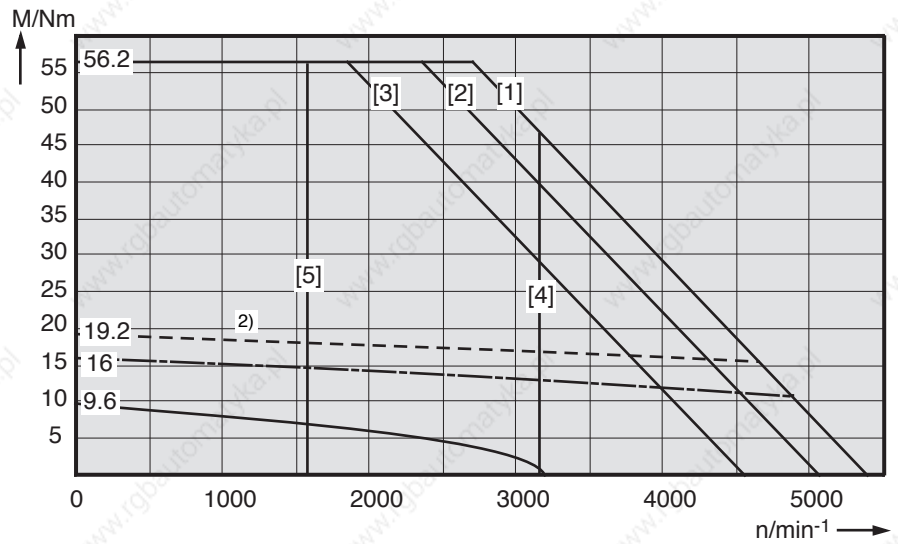

MAC 090 C - - - E •
5000 min⁻¹

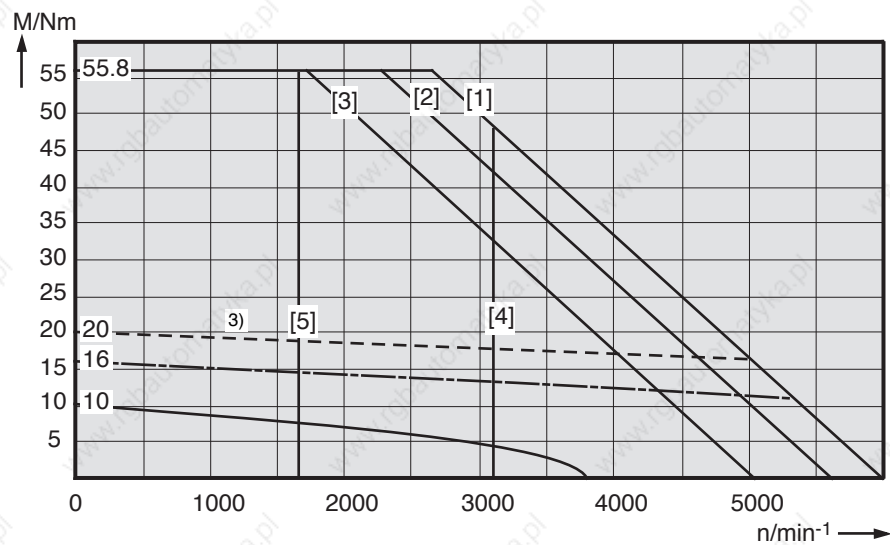

- 1) shown: ON time of surface-cooled motor 59%
- 2) shown: ON time of surface-cooled motor 69%
- 3) shown: ON time of surface-cooled motor 64%

Fig 5.7: Torque-speed characteristics MAC 090

5.3. Shaft load capacity

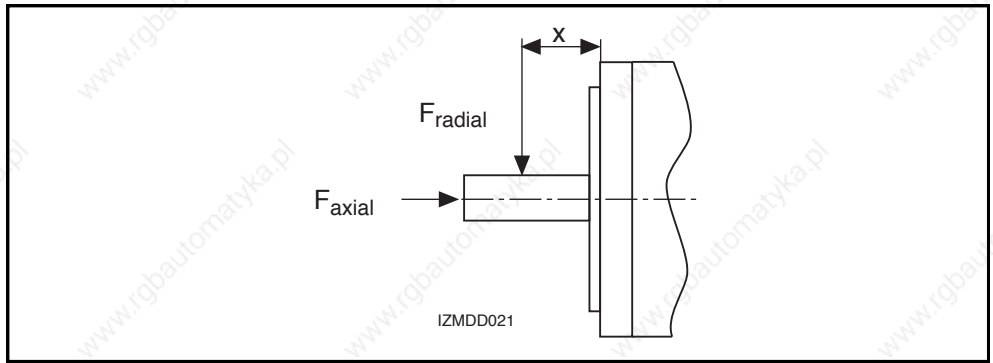

Fig 5.8: Shaft load

Permissible radial force
 F_{radial}

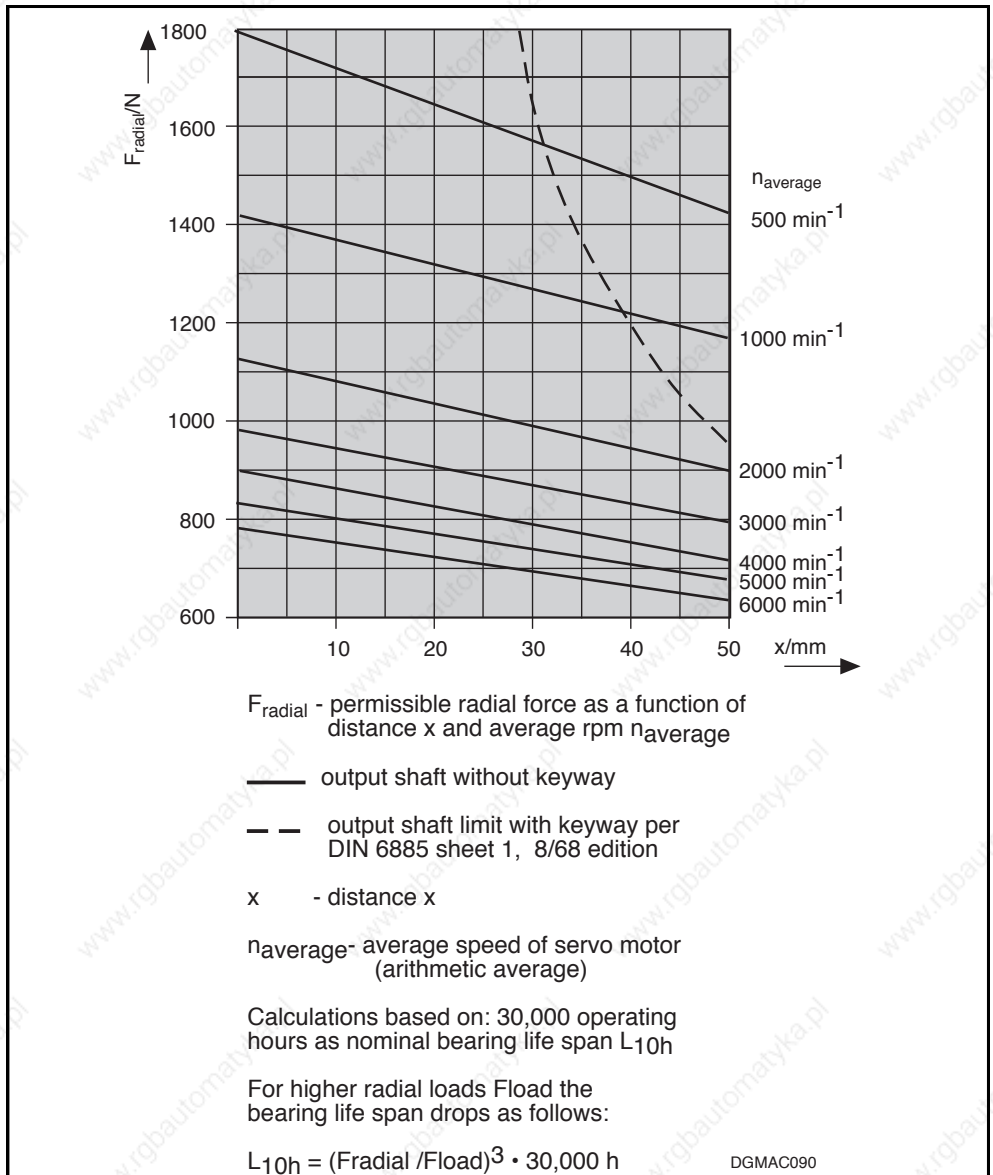

Fig 5.9: Permissible radial force

Permissible axial force
 F_{axial}

$$F_{axial} = 0.34 \cdot F_{radial}$$

F_{axial} - Permissible axial force
 F_{radial} - Permissible radial force

5.4. Dimensional data - natural convection

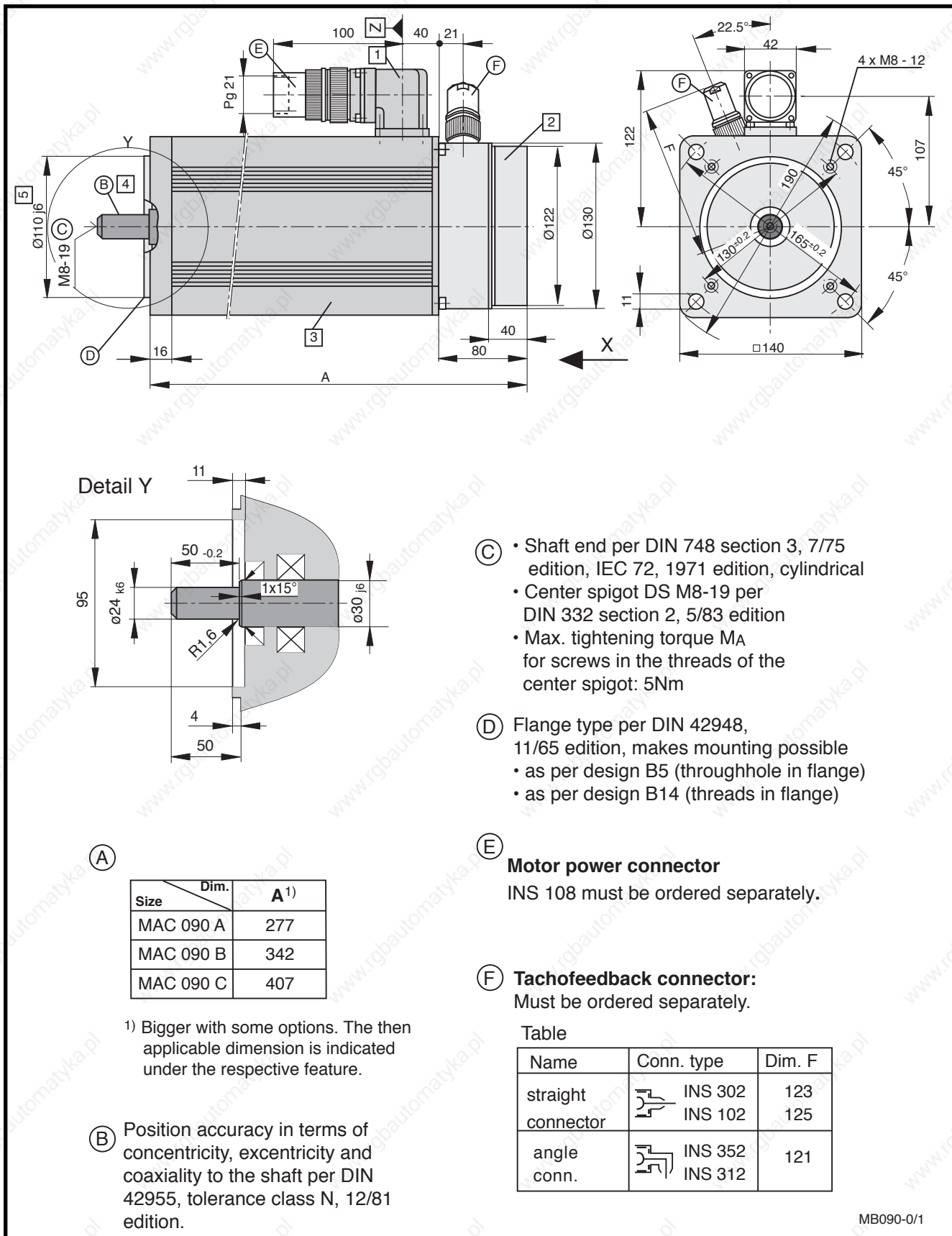

Fig 5.10: Dimensional data - MAC 090 (natural convection)

MB090-0/1

Available options

1 Power connection

The output direction of the electrical power connector is selected at the time the order is placed. Possible output directions are:

- to side A
- to side B
- to the right
- to the left

The drawing depicts side A as output direction. The dimensions of any other direction are obtained by a virtual turning of the connector housing around the Z axis.

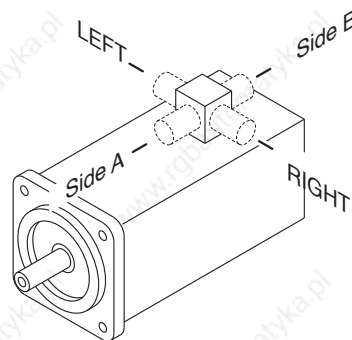

2 Motor version

- Tachofeedback and second shaft end

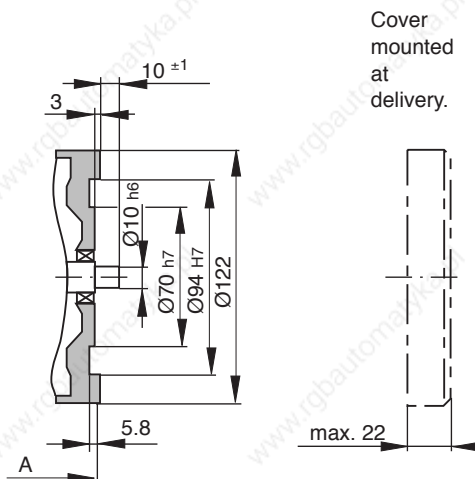
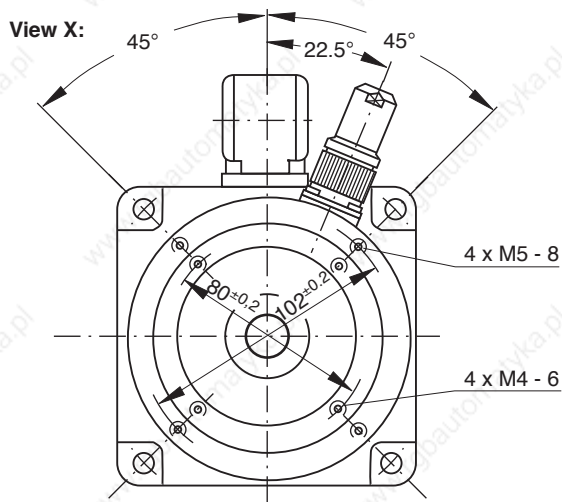

- Tachofeedback and mounted incremental encoder

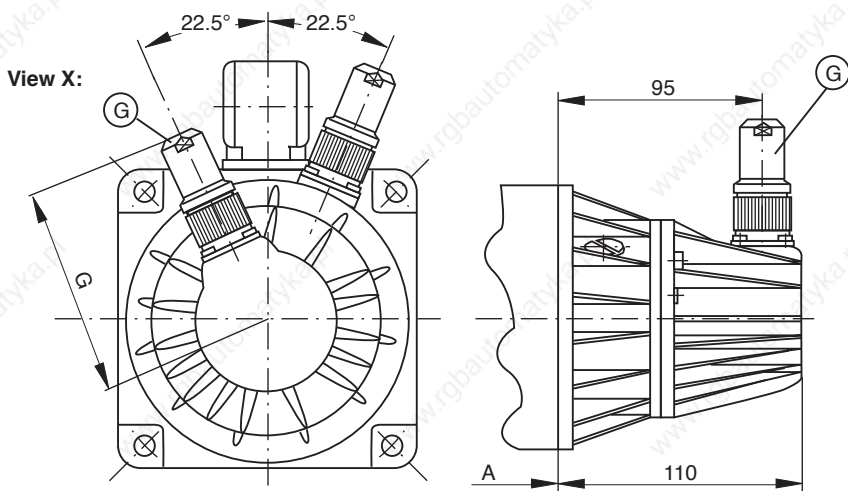

G Incremental encoder connector

Must be ordered separately.

Name	Conn. type	Dim. G
straight conn.	INS 301	88
	INS 101	90
angle conn.	INS 351	86
	INS 311	

- Tachofeedback and mounted absolute encoder (see following page)

MB090-0/2

Fig 5.11: Dimensional data - MAC 090 - available options - (natural convection)

Available options

- Tachofeedback and mounted absolute encoder

View X:

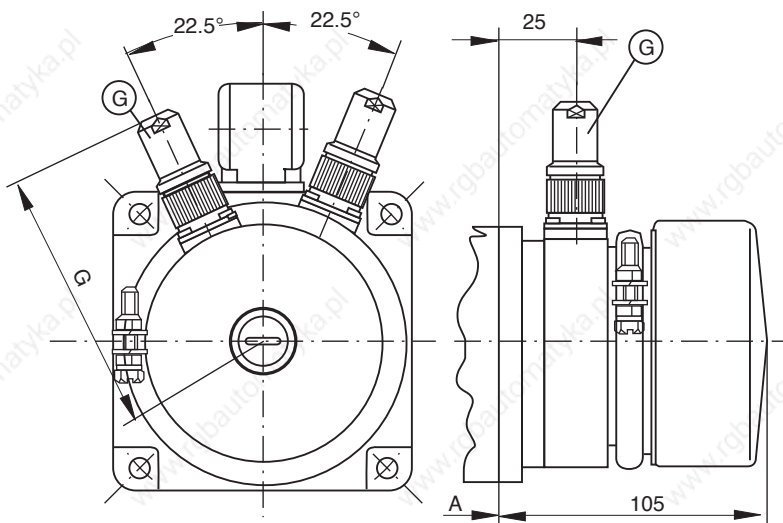

G Absolute encoder conn.
Must be ordered separately.

Name	Conn. type	Dim. G
straight conn.	INS 326	104
	INS 92	106
angle conn.	INS 322	102

3 Blocking brake

- without blocking brake
Dim. A retained
- Standard blocking brake: 6.5 Nm
Dim. A retained
- heavy-duty blocking brake: 14.0 Nm

Table for 14 Nm blocking brake

Size	Dim.	A
MAC 090 A		327
MAC 090 B		392
MAC 090 C		457

4 Output shaft

- plain shaft (recommended type)
- with keyway per DIN 6885 sh. 1, 8/68 edition
(Note! balanced with entire key.)

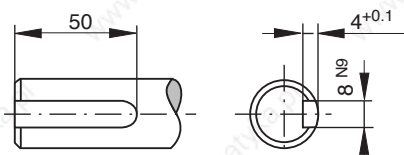

Matching key: DIN 6885-A 5 x 5 x 22
Must be ordered separately.

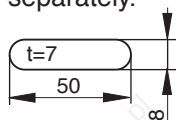

5 Special centering diameter

- Ø130 j6

MB090-0/3

Fig 5.12: Dimensional data - MAC 090 - available options - (natural convection)

5.5. Dimensional data - radial cooling

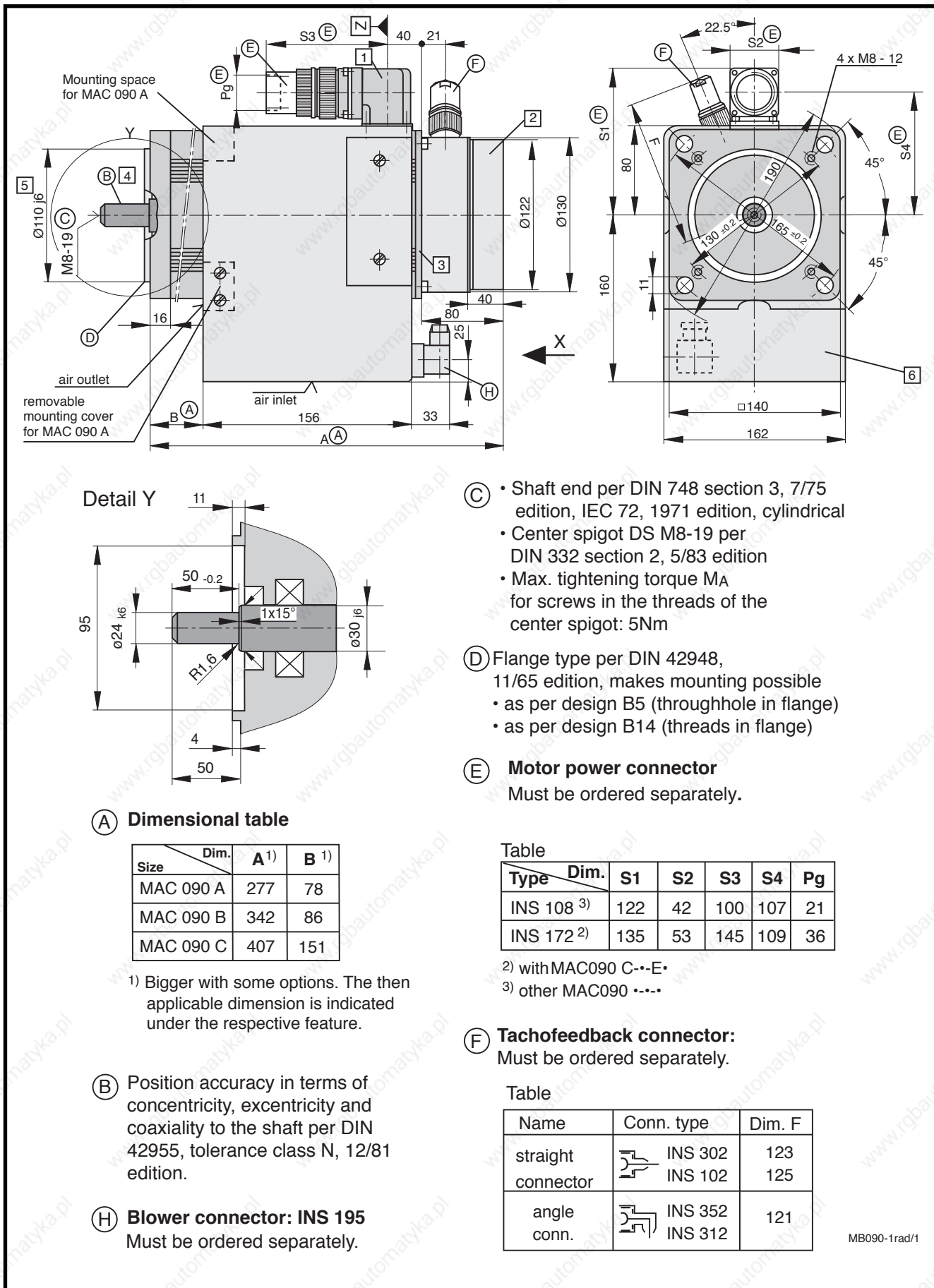

Fig 5.13: Dimensional data - MAC 090 (radial cooling)

Available options

1 Power connection

The output direction of the electrical power connector is selected at the time the order is placed. Possible output directions are:

- to side A
- to side B
- to the right
- to the left

The drawing depicts side A as output direction. The dimensions of any other direction are obtained by a virtual turning of the connector housing around the Z axis.

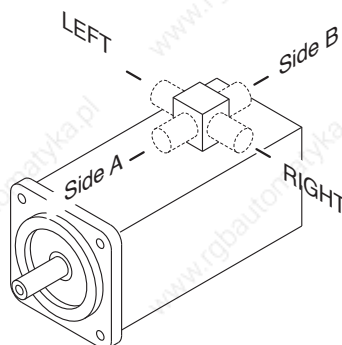

2 Motor version

- Tachofeedback and second shaft end

View X:

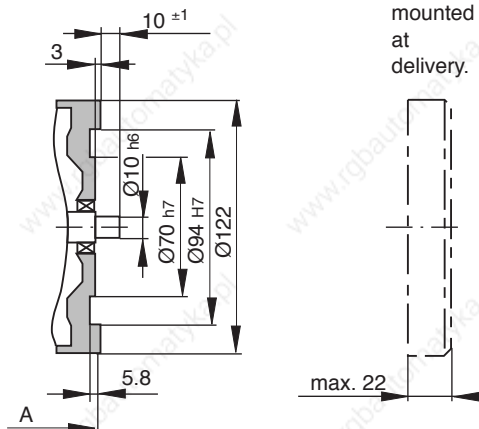
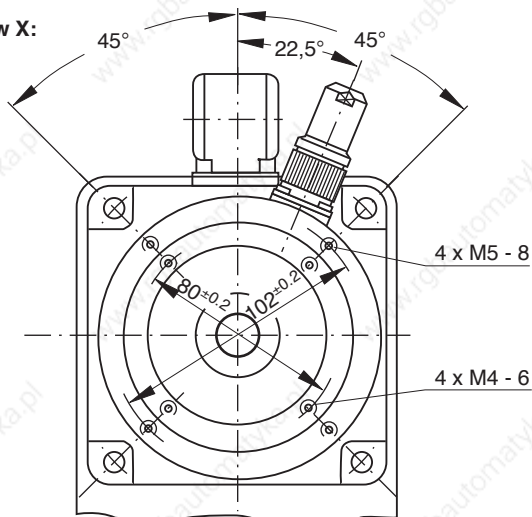

- Tachofeedback and mounted incremental encoder

View X:

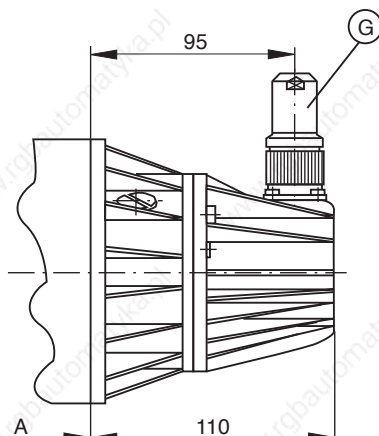
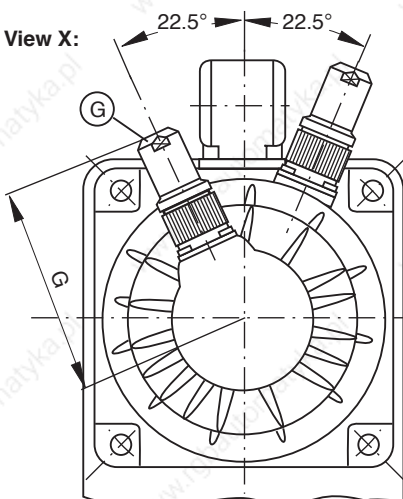

G Incremental encoder connector

Must be ordered separately.

Name	Conn. type	Dim. G
straight conn.	INS 301	88
	INS 101	90
angle conn.	INS 351 INS 311	86

- Tachofeedback and mounted absolute encoder (see following page)

MB090-1rad/2

Fig 5.14: Dimensional data - MAC 090 - available options - (radial cooling)

Available options

- Tachofeedback and mounted absolute encoder

View X:

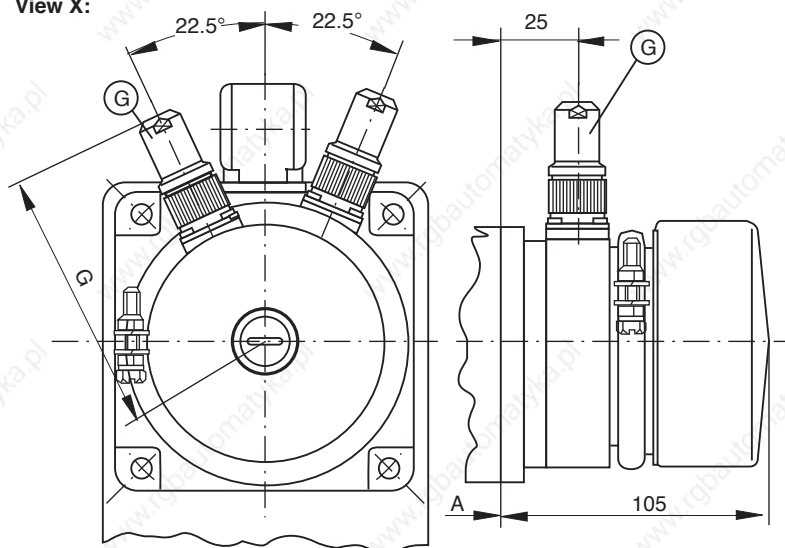

Ⓒ **Absolute encoder conn.**
Must be ordered separately.

Name	Conn. type	Dim. G
straight conn.	INS 326	104
	INS 92	
angle conn.	INS 322	102

3 Blocking brake

- without blocking brake
Dim. A and B retained
- Standard blocking brake: 6.5 Nm
Dim. A and B retained
- heavy-duty blocking brake: 14.0 Nm

Table for 14 Nm blocking brake

Size	Dim.	A	B
MAC 090 A		327	128
MAC 090 B		392	136
MAC 090 C		457	185

4 Output shaft

- plain shaft (recommended type)
- with keyway per DIN 6885 sh. 1, 8/68 edition
(Note! balanced with entire key.)

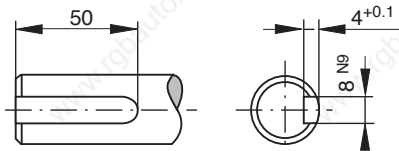

Matching key: DIN 6885-A 5 x 5 x 22
Must be ordered separately.

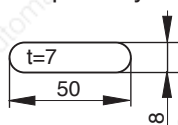

5 Special centering diameter

- $\varnothing 130 j6$

6 Blower arrangement

Looking towards motor shaft.

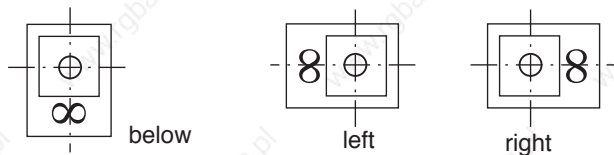

MB090-1rad/3

Fig 5.15: Dimensional data - MAC 090 - available options - (radial cooling)

5.6. Dimensional data - axial cooling

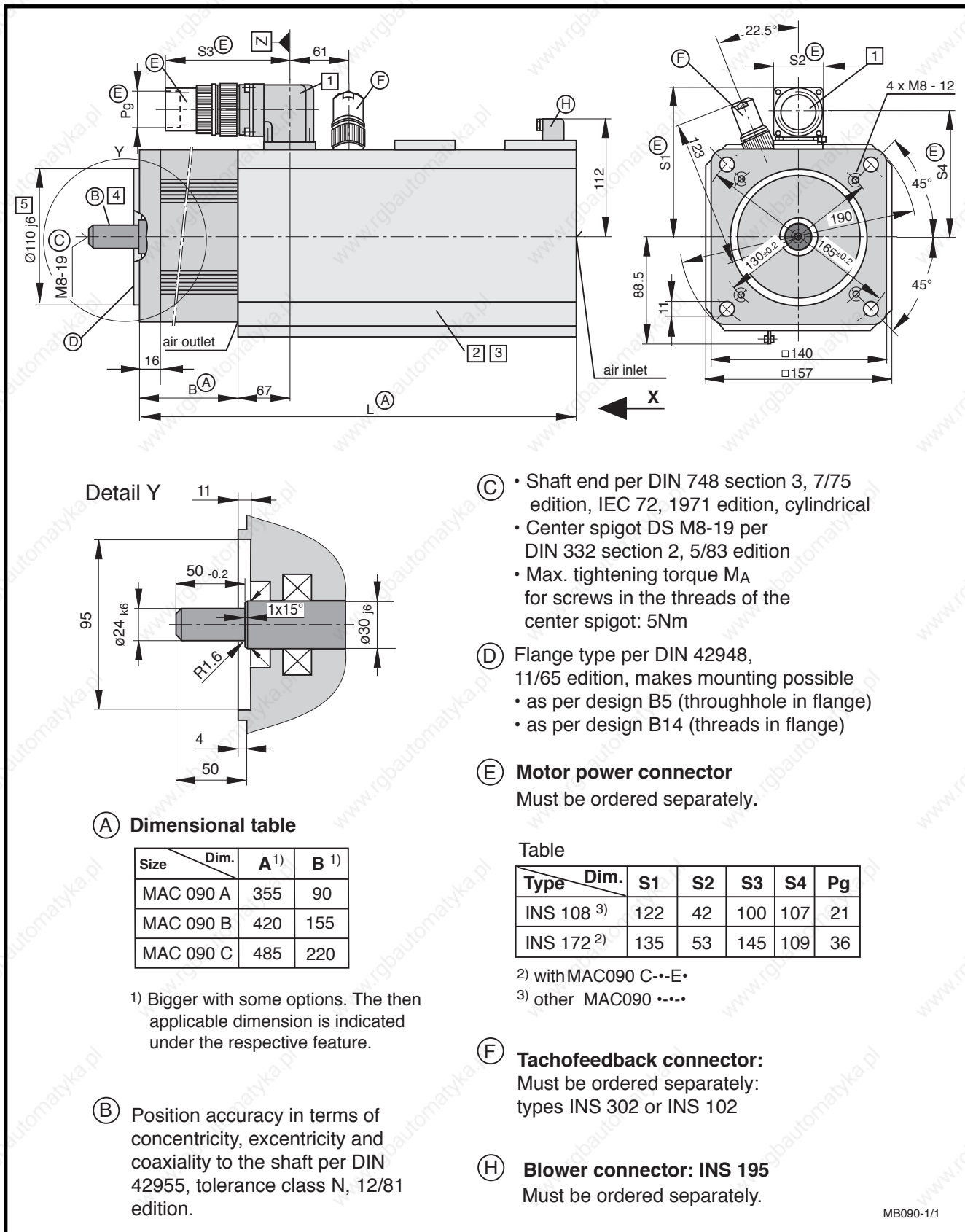

Fig 5.16: Dimensional data - MAC 090 (axial cooling)

Available options

1 Power connection

The output direction of the electrical power connector is selected at the time the order is placed. Possible output directions are:

- to side A
- to side B
- to the right
- to the left

The drawing depicts side A as output direction. The dimensions of any other direction are obtained by a virtual turning of the connector housing around the Z axis.

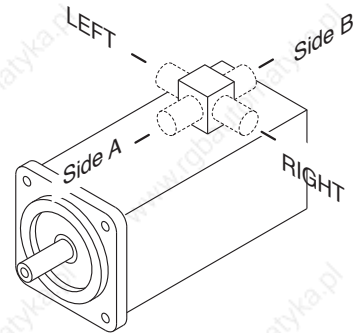

2 Motor version

- Tachofeedback and mounted incremental encoder

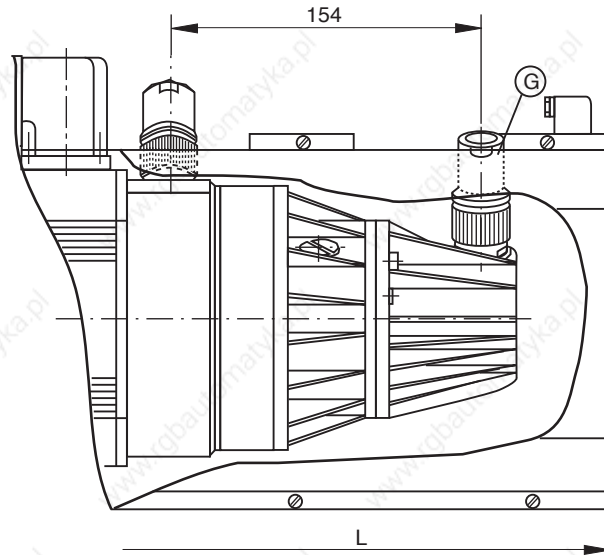
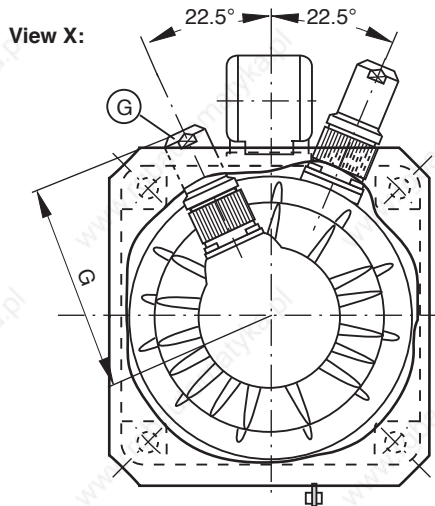

G Incremental encoder connector

Must be ordered separately.



Name	Conn. type	Dim. G
straight	 INS 301	123
conn.	 INS 101	125

Table:

Size	Dim.	L	B
MAC 090 A		455	90
MAC 090 B		520	155
MAC 090 C		585	220

- Tachofeedback and mounted absolute encoder (see following page)

MB090-1/2

Fig 5.17: Dimensional data - MAC 090 - available options - (axial cooling)



Available options

- Tachofeedback and mounted absolute encoder

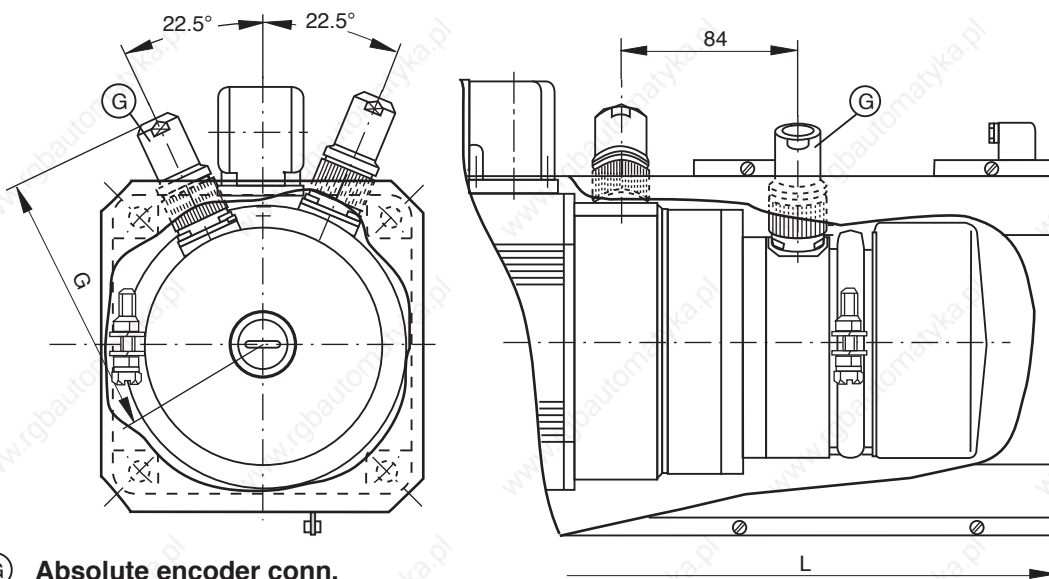
View X:



Ⓒ **Absolute encoder conn.**
Must be ordered separately.

Name	Conn. type	Dim. G
straight conn.	INS 326 	104
	INS 92 	106

Size	Dim.	L	B
MAC 090 A		455	90
MAC 090 B		520	155
MAC 090 C		585	220

3 Blocking brake

- without blocking brake
Dim. L and B retained
- Standard blocking brake: 6.5 Nm
Dim. L and B retained
- heavy-duty holding brake: 14.0 Nm

Table for blocking brake with 14.0 Nm holding torque

Size	Dim.	Vers. 2		Vers. 4	
		L	B	L	B
MAC 090 A		405	140	505	140
MAC 090 B		470	205	570	205
MAC 090 C		535	270	635	270

Vers. 2 = Motor with tachofeedback

Vers. 4 = Motor with tachofeedback and mounted encoder

4 Output shaft

- plain shaft (recommended type)
- with keyway per DIN 6885 sh. 1, 8/68 edition
(Note! balanced with entire key.)

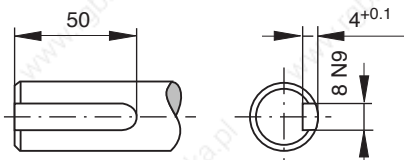

Matching key: DIN 6885-A 8 x 7 x 50
Must be ordered separately.

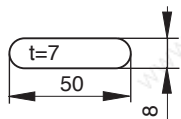

5 Special centering diameter

- Ø130 j6

MB090-1/3

Fig 5.18: Dimensional data - MAC 090 -available options - (axial cooling)

5.7. Available Options

Type code fields		Example:	MAC 090 A-0-ES-4 - C/110-A-0/WI 520LV/S000								
1. Motor for analogue drives	MAC										
2. Motor size	090										
3. Motor length	A, B, C										
4. Type of cooling:											
natural convection		surface cooling									
		axial				radial					
				blower right		blower below		blower left			
		AC 230 V	AC 115 V	AC 230 V	AC 115 V	AC 230 V	AC 115 V	AC 230 V	AC 115 V		
0		1 ¹⁾	2 ¹⁾	6	A	7	B	8	C		
5. Type of windings											
Nominal rpm	Standard applications				with increased smooth run quality						
	motor length				motor length						
	A	B	B	C	A	B	B	C			
2000 min ⁻¹	ZD	PD	--	KD	ZG	PG	--	KG			
3000 min ⁻¹	RD	ND	JD	GD	RG	NG	JG	GG			
5000 min ⁻¹	--	--	--	ED	--	--	--	EG			
6. Motor feedback											
Motor type											
with tachofeedback										2	
with tachofeedback and second shaft end										3	
with tachofeedback and mounted incremental or absolute encoder										4	
Tacho voltage											
set to nominal motor speed										-	
(nominal rpm > 3000 min ⁻¹)		: 1,5 V/1000 min ⁻¹									
(nominal rpm ≤ 3000 min ⁻¹)		: 3 V/1000 min ⁻¹									
1,5 V/1000 min ⁻¹										H	
6 V/1000 min ⁻¹										L	
Tacho type											
Standard										C	
increased smooth run quality										F	
7. Centering diameter											
for design B05 and B14										110	
for design B05 and B14										130 ²⁾	
8. Power connection											
connector to side A										A	
connector to side B										B	
connector to right (looking onto output shaft)										R	
connector to left (looking onto output shaft)										L	
9. Blocking brake											
without blocking brake										0	
with standard blocking brake (6.5 Nm)										1	
with heavy-duty blocking brake (14 Nm)										2	
Mounted encoder	10. Type ³⁾										
	Incremental encoder with standard mounting										WI
	Incremental encoder with shock-damped mounting										DI
	11. Encoder code ³⁾										
										For available types, see section 2.4 "Motor feedback"	
12. Special types											
Fixed and documented by INDRAMAT with special number (see Drawing no.: 106-0105-4301-XX)											
Does not apply to standard motors.											
<p>1) For type 3 motors (with 2nd shaft end and tachofeedback). Not available with axial surface cooling.</p> <p>2) additional S0 no. required (see Fig. 5.20)</p> <p>3) type code fields 10 and 11 do not apply to motor types 2 and 3</p>											

Fig 5.19: Type codes - MAC 090

TLMAC090

5.8. Special Options

Specification of Option	S003	S005	S012	S013	S019	S023	S031
Special centering diameter 130	X		X		X		X
Heavy-duty blocking brake				X	X	X	X
output shaft with shaft sealing		X	X			X	X

Fig 5.20: Special options with a MAC 090

6. MAC 093

6.1. Technical Data

Designation	Symbol	Unit	Motor type MAC ...		
			093 A - - - WS	093 B - - - OS	093 C - - - KS
Nominal motor speed ¹⁾	n	min ⁻¹	2000	2000	2000
Continuous torque at standstill ²⁾	M _{dN}	Nm	9.2 (12.0) ⁵⁾	14.5 (20.0) ⁵⁾	19.5 (28.0) ⁵⁾
Continuous current at standstill	I _{dN}	A	11(14) ⁵⁾	18 (25) ⁵⁾	22 (32) ⁵⁾
Rotor moment of inertia ³⁾	J _M	kgm ²	22 x 10 ⁻⁴	29 x 10 ⁻⁴	42 x 10 ⁻⁴
Torque constant at 20 °C	K _m	Nm/A	0.875	0.831	0.910
Windings resistance at 20 °C	R _A	Ohm	1.313	0.625	0.433
Windings inductance	L _A	mH	16.0	9.0	7.0
Maximum peak of pulse current	I _{peak}	A	54	89	110
Thermal time constant	T _{th}	min	50 (30) ⁵⁾	50 (45) ⁵⁾	50 (45) ⁵⁾
Mass ⁴⁾	m _M	kg	13.0	16.5	22.0
			093 A - - - PS	093 B - - - JS	093 C - - - FS
Nominal motor speed ¹⁾	n	min ⁻¹	3000	3000	3000
Continuous torque at standstill ²⁾	M _{dN}	Nm	9.2 (12.0) ⁵⁾	14.5 (18.3) ⁵⁾	19.5 (28.0) ⁵⁾
Continuous current at standstill	I _{dN}	A	15 (20) ⁵⁾	27 (34) ⁵⁾	35 (50) ⁵⁾
Rotor moment of inertia ³⁾	J _M	kgm ²	22 x 10 ⁻⁴	29 x 10 ⁻⁴	42 x 10 ⁻⁴
Torque constant at 20 °C	K _m	Nm/A	0.620	0.554	0.579
Windings resistance at 20 °C	R _A	Ohm	0.659	0.227	0.175
Windings inductance	L _A	mH	8.0	4.0	2.9
Maximum peak of pulse current	I _{peak}	A	76	134	173
Thermal time constant	T _{th}	min	50 (45) ⁵⁾	50 (45) ⁵⁾	50 (45) ⁵⁾
Mass ⁴⁾	m _M	kg	13.0	16.5	22.0
			093 A - - - LS	093 B - - - GS	093 C - - - DS
Nominal motor speed ¹⁾	n	min ⁻¹	4000	4000	4000
Continuous torque at standstill ²⁾	M _{dN}	Nm	9.2 (12.0) ⁵⁾	14.5 (20.0) ⁵⁾	19.5 (28.0) ⁵⁾
Continuous current at standstill	I _{dN}	A	22 (28) ⁵⁾	38 (53) ⁵⁾	48 (69) ⁵⁾
Rotor moment of inertia ³⁾	J _M	kgm ²	22 x 10 ⁻⁴	29 x 10 ⁻⁴	42 x 10 ⁻⁴
Torque constant at 20 °C	K _m	Nm/A	0.438	0.388	0.413
Windings resistance at 20 °C	R _A	Ohm	0.328	0.136	0.089
Windings inductance	L _A	mH	4.0	2.0	1.5
Maximum peak of pulse current	I _{peak}	A	108	192	242
Thermal time constant	T _{th}	min	50 (45) ⁵⁾	50 (45) ⁵⁾	50 (45) ⁵⁾
Mass ⁴⁾	m _M	kg	13.0	16.5	22.0
			093 A - - - HS	093 B - - - ES	093 C - - - CS
Nominal motor speed ¹⁾	n	min ⁻¹	6000	6000	6000
Continuous torque at standstill ²⁾	M _{dN}	Nm	9.2 (9.8) ⁵⁾	14.5 (20.0) ⁵⁾	19.5 (28.0) ⁵⁾
Continuous current at standstill	I _{dN}	A	32 (34) ⁵⁾	54 (74) ⁵⁾	60 (87) ⁵⁾
Rotor moment of inertia ³⁾	J _M	kgm ²	22 x 10 ⁻⁴	29 x 10 ⁻⁴	42 x 10 ⁻⁴
Torque constant at 20 °C	K _m	Nm/A	0.292	0.277	0.331
Windings resistance at 20 °C	R _A	Ohm	0.146	0.069	0.057
Windings inductance	L _A	mH	1.8	1.0	0.9
Maximum peak of pulse current	I _{peak}	A	162	268	302
Thermal time constant	T _{th}	min	50 (45) ⁵⁾	50 (45) ⁵⁾	50 (45) ⁵⁾
Mass ⁴⁾	m _M	kg	13.0	16.5	22.0

¹⁾ The usable motor speed is determined by the drive used.
 Only those usable speeds n_{max} found in the selection lists of the motor-drive combinations are binding.
²⁾ With 60K overtemperature at the motor housing.
 Continuous torque can be limited by the drive. See selection data.
³⁾ With tacho-generator, without holding brake
⁴⁾ With tacho-generator, without holding brake, without blower.
⁵⁾ Parenthetical values apply to versions with surface cooling.

Fig 6.1: Type-dependent motor data

Designation	Symbol	Unit	Data	
Permissible ambient temperature	T_{um}	°C	0 ... + 45	
Permissible storage and transport temperature	T_L	°C	-20 ... +80	
Maximum installation elevation		m	1000 m. above sea level	
Protection category			IP 65	
Insulation classification			F	
Housing coat			Black prime coat (RAL 9005)	
Voltage constant of the tachogenerator ¹⁾	C_w	Vs/rad V/min ⁻¹	0.0143 1.5/1000	0.0286 3/1000

¹⁾ Tachovoltage can be selected application-related.

Fig 6.2: General data MAC 093

Designation	Symbol	Unit	Data holding brake		
			Standard	heavy-duty electrically actuated release	extra heavy-duty
Principle of action					
Holding torque	M_H	Nm	6.5	14	22
Nominal voltage	U_N	V		DC 24 ± 10%	
Nominal current	I_N	A	0.7	0.7	0.7
Moment of inertia	J_B	kgm ²	1.06 x 10 ⁻⁴	3.6 x 10 ⁻⁴	3.6 x 10 ⁻⁴
Release delay	t_L	ms	60	70	70
Clamping delay	t_K	ms	20	30	30
Mass	m_B	kg	0.6	1.1	1.1

Fig 6.3: Technical data - holding brake

Designation	Symbol	Unit	Axial cooling	Radial cooling
Power consumption	S_N	VA	40/42	40/42
Nominal voltage	U_N	V	AC 230 or 115 ¹⁾	AC 230 or 115 ¹⁾
Frequency	f	Hz	50/60	50/60
Mass	m_L	kg	approx. 3.3 ²⁾	approx. 3.2 ²⁾
Protection category blower unit			IP 24	IP 24
Protection category blower motor			IP 44	IP 44

¹⁾ 115 V special design
²⁾ Blower shroud for motor with tachofeedback.

Fig 6.4: Technical data - surface cooling

6.2. Torque-Speed Characteristics

MAC 093 A - - - WS
2000 min⁻¹

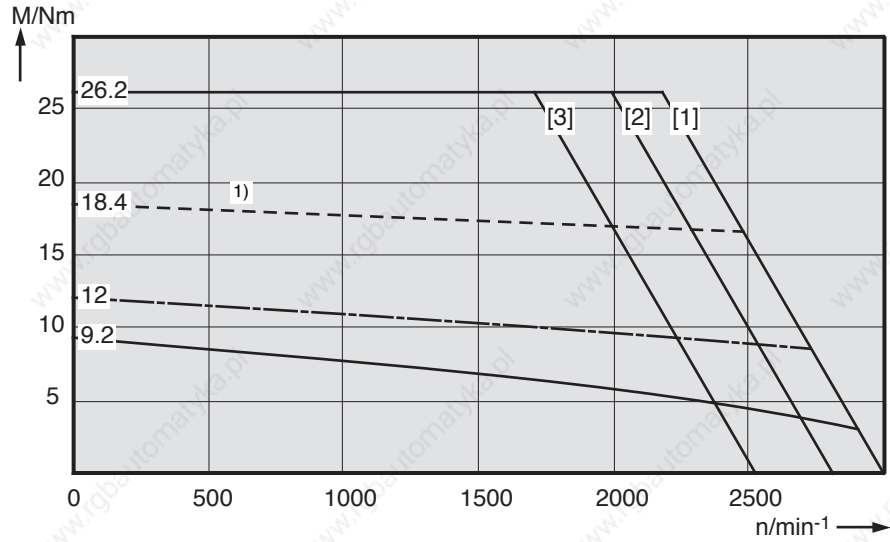

MAC 093 A - - - PS
3000 min⁻¹

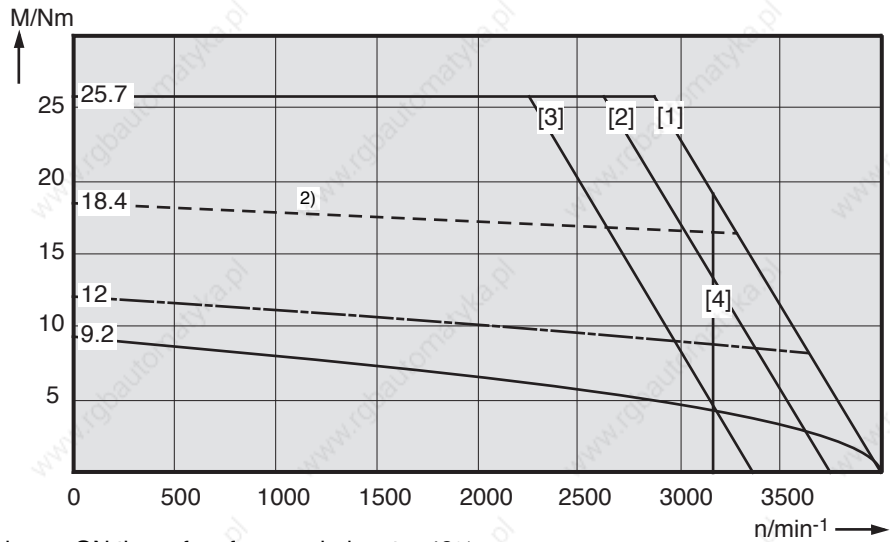

1) shown: ON time of surface-cooled motor 48%
2) shown: ON time of surface-cooled motor 40%

Fig 6.5: Torque-speed characteristics MAC 093

MAC 093 A - - - LS
4000 min⁻¹

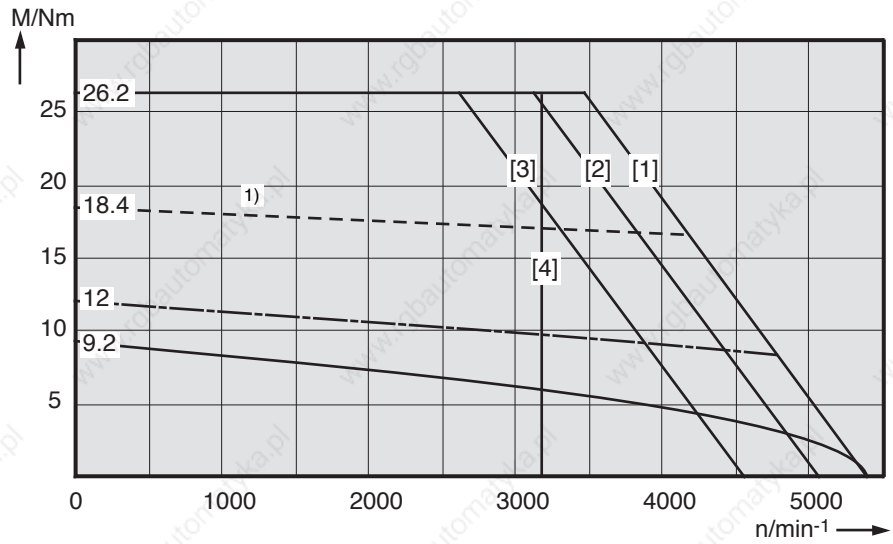

MAC 093 A - - - HS
6000 min⁻¹

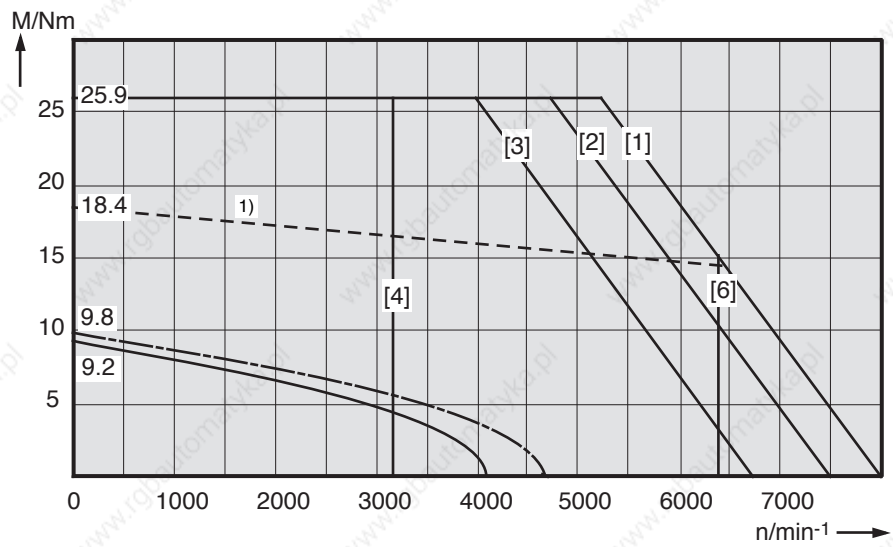

1) shown: ON time of surface-cooled motor 48%

Fig 6.6: Torque-speed characteristics MAC 093

MAC 093 B - • - OS
2000 min⁻¹

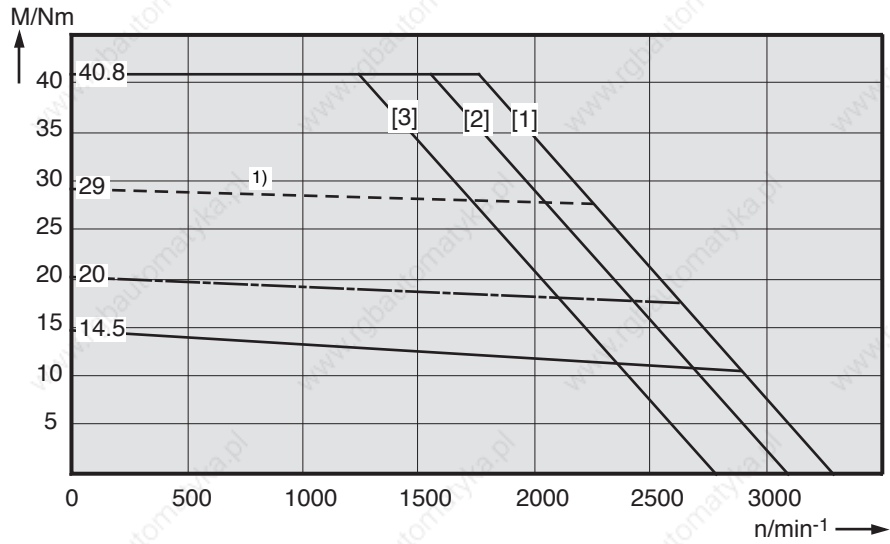

MAC 093 B - • - JS
3000 min⁻¹

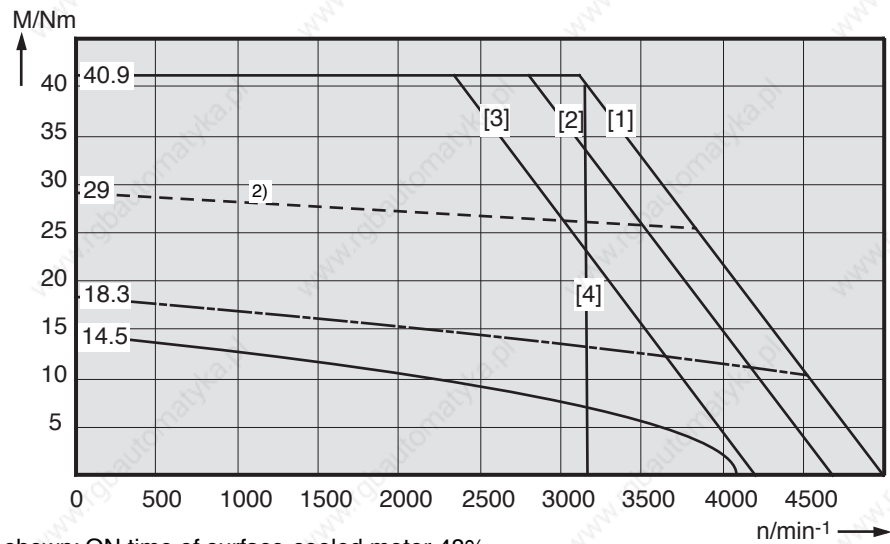

1) shown: ON time of surface-cooled motor 48%
1) shown: ON time of surface-cooled motor 40%

Fig 6.7: Torque-speed characteristics MAC 093

MAC 093 B - - - GS
4000 min⁻¹

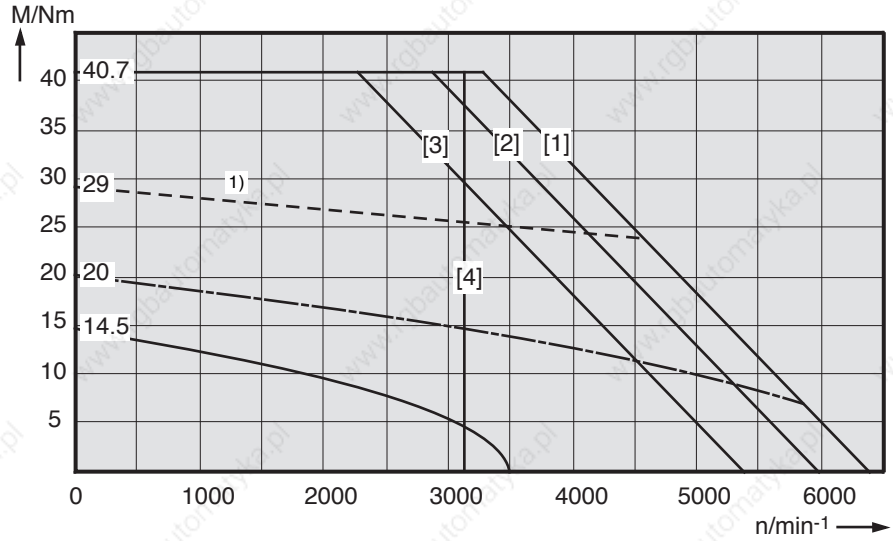

MAC 093 B - - - ES
6000 min⁻¹

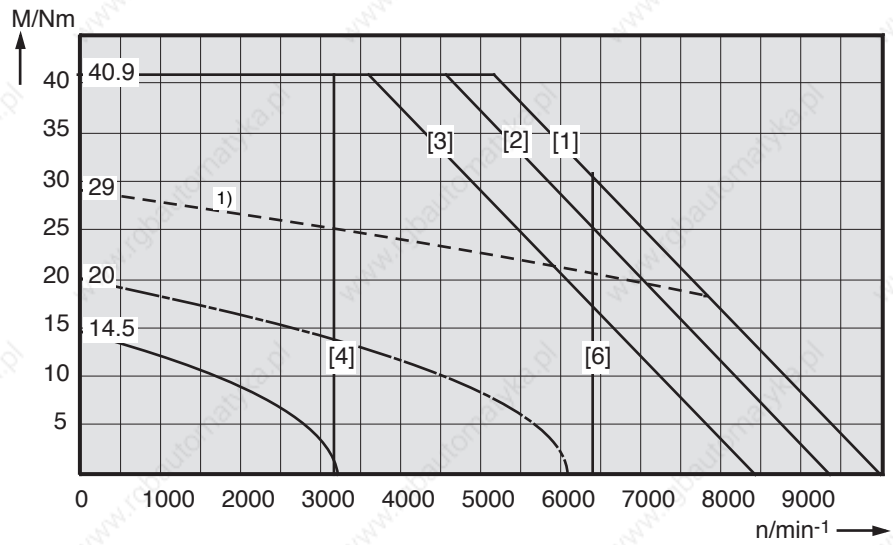

1) shown: ON time of surface-cooled motor 48%

Fig 6.8: Torque-speed characteristics MAC 093

MAC 093 C - - - KS
2000 min⁻¹

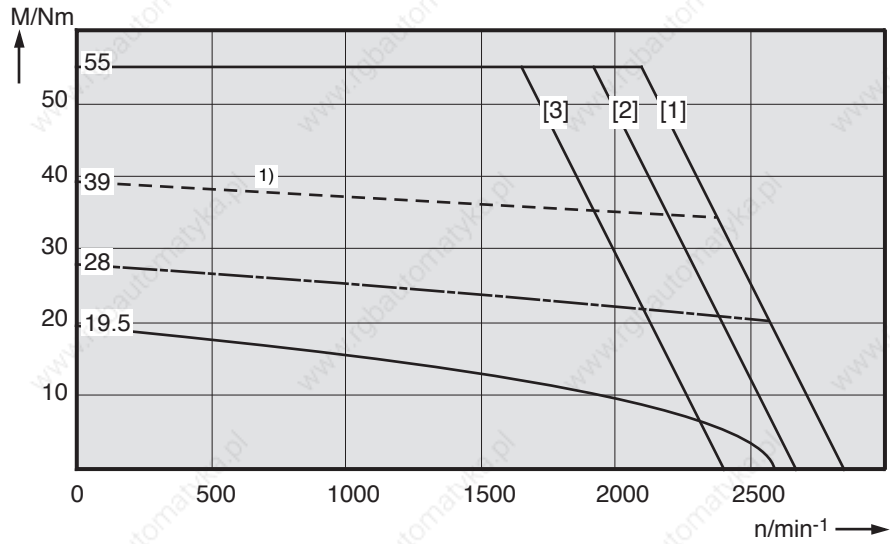

MAC 093 C - - - FS
3000 min⁻¹

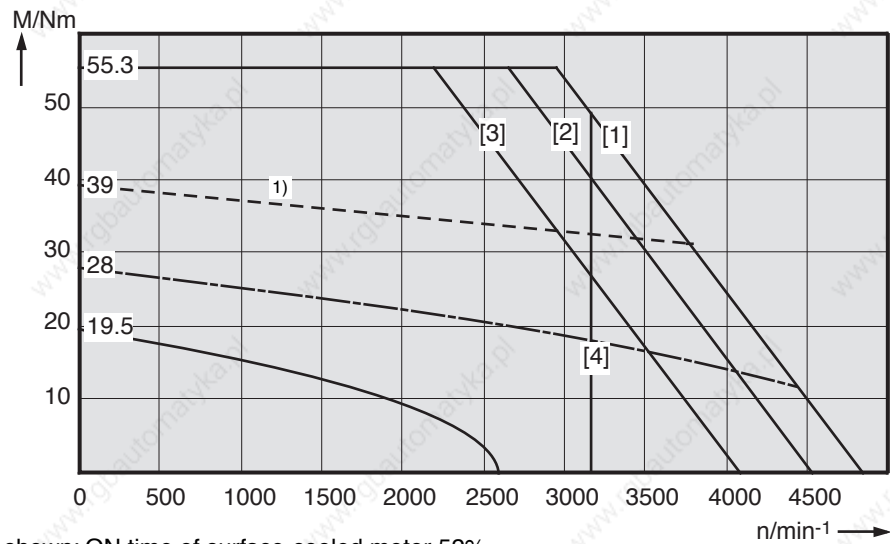

¹⁾ shown: ON time of surface-cooled motor 52%

Fig 6.9: Torque-speed characteristics MAC 093

MAC 093 C - - - DS
4000 min⁻¹

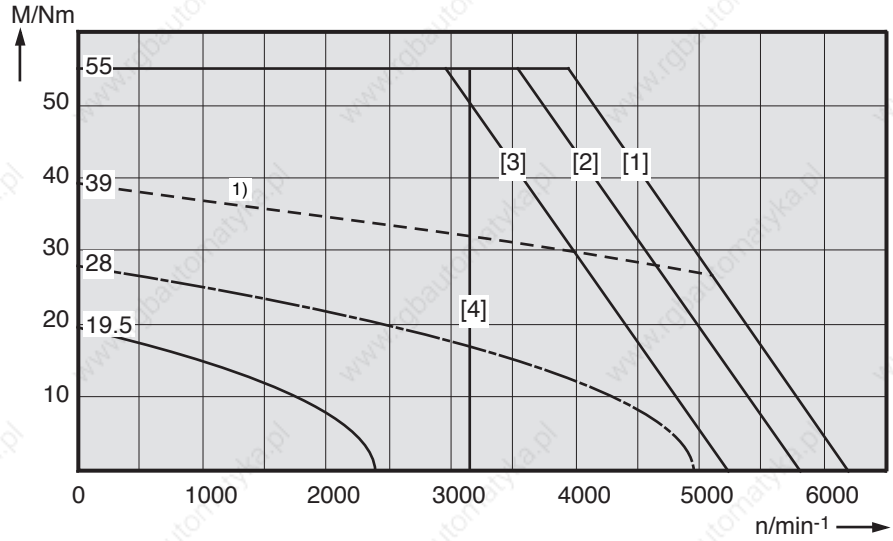

MAC 093 C - - - CS
6000 min⁻¹

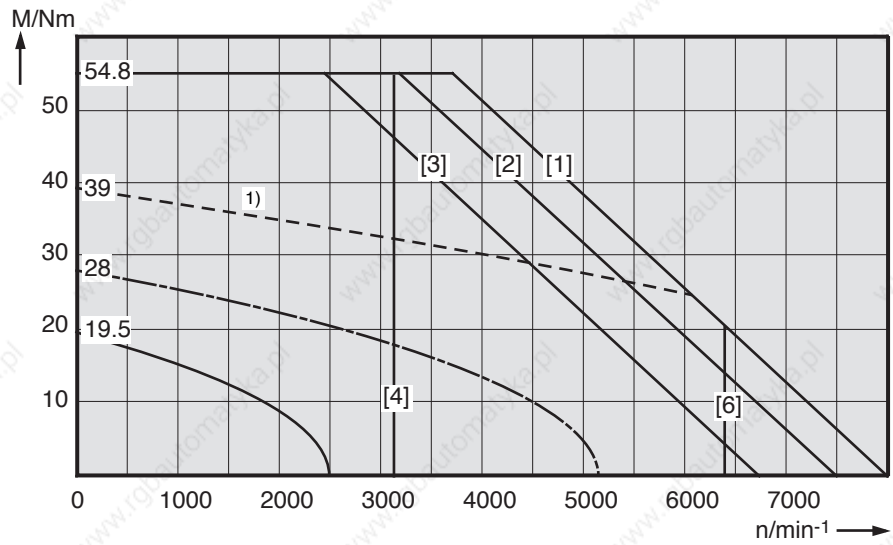

1) shown: ON time of surface-cooled motor 52%

Fig 6.10: Torque-speed characteristics MAC 093

6.3. Shaft load capacity

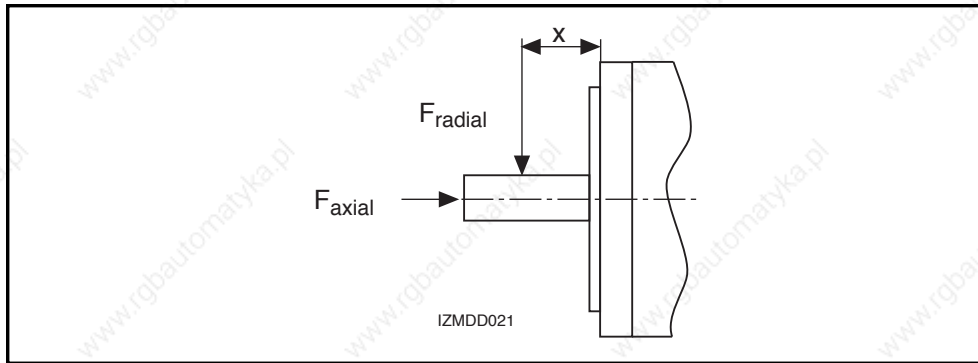

Fig 6.11: Shaft load

Permissible radial force
 F_{radial}

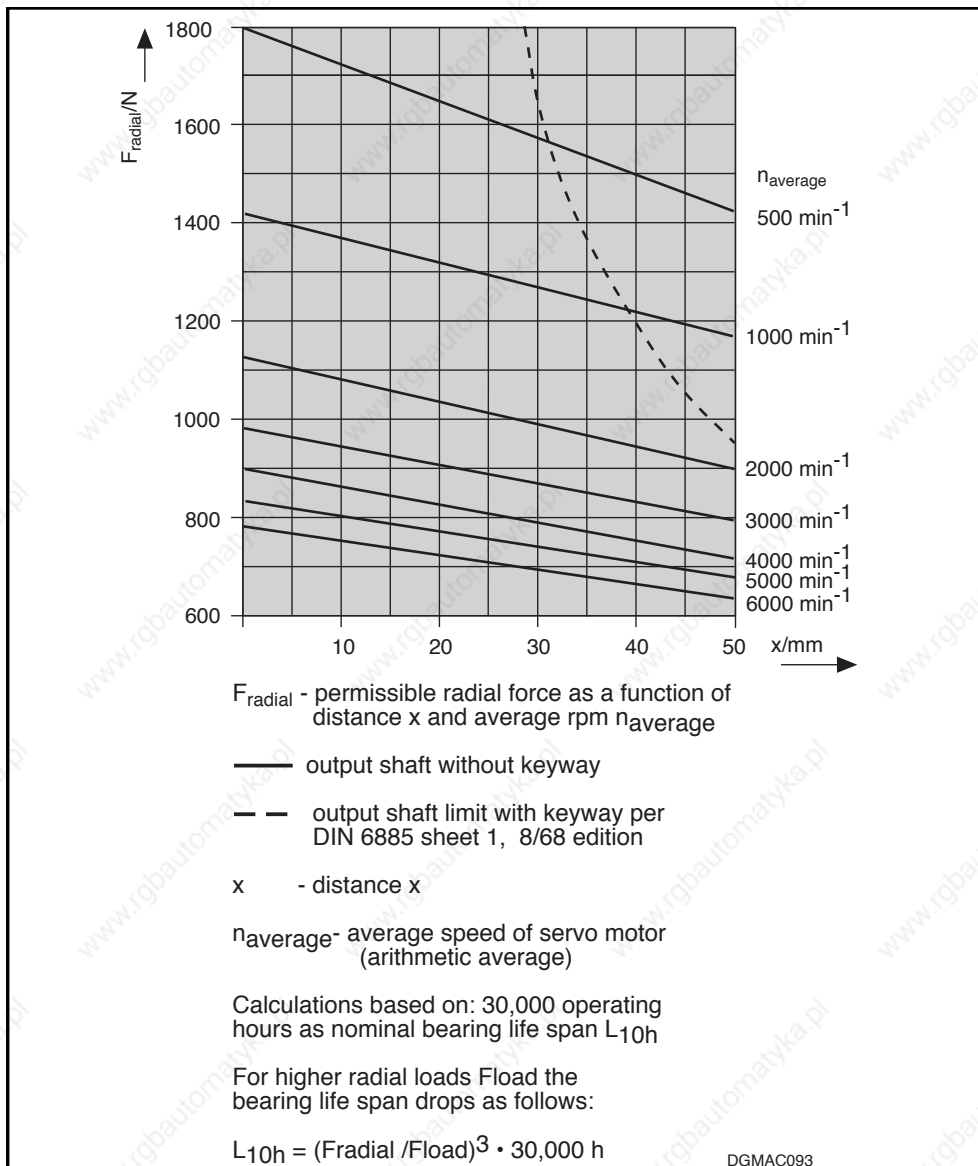

Fig 6.12: Permissible radial force

Permissible axial force
 F_{axial}

$$F_{axial} = 0.34 \cdot F_{radial}$$

F_{axial} - Permissible axial force
 F_{radial} - Permissible radial force

6.4. Dimensional data - natural convection

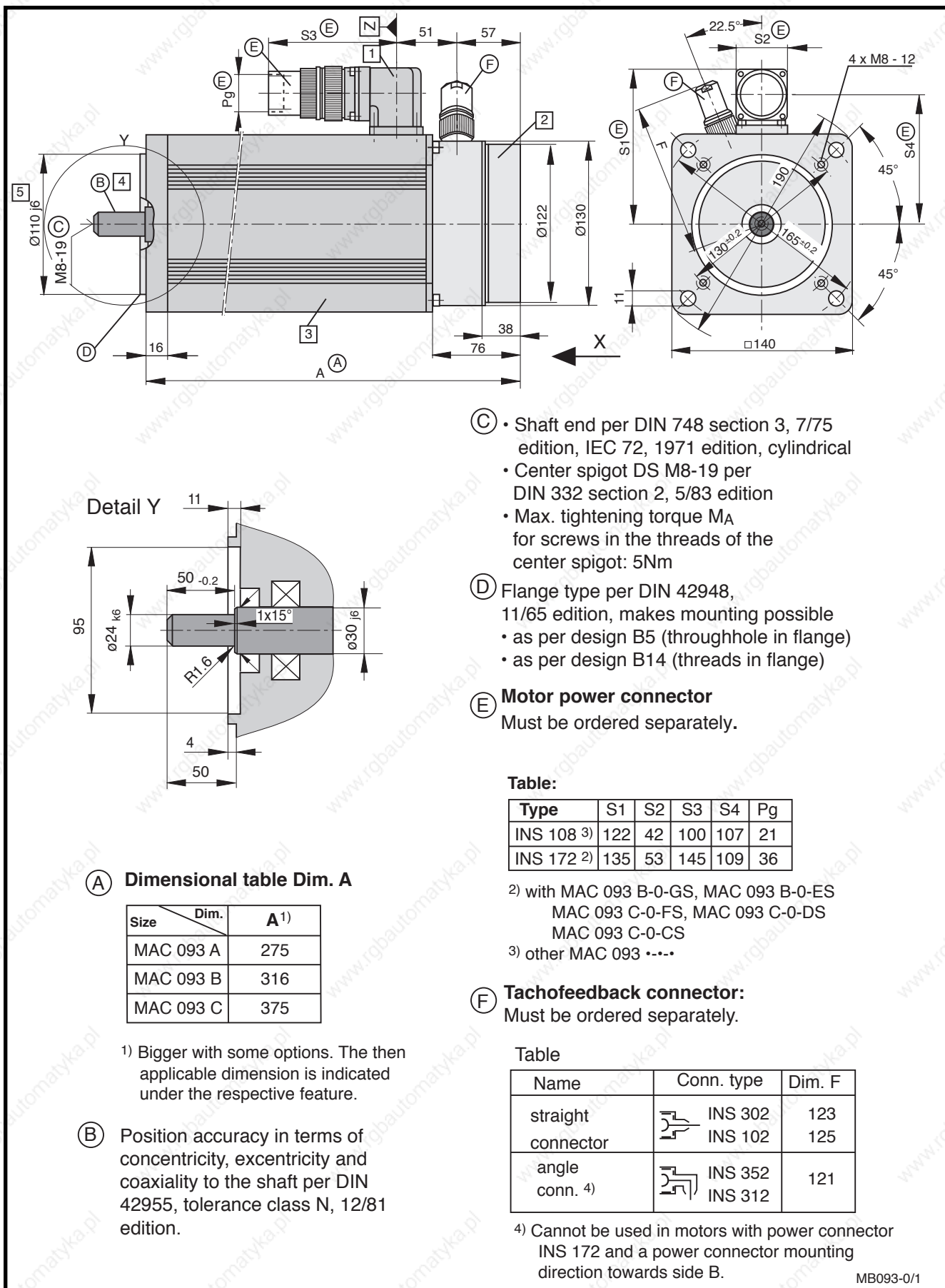

Fig 6.13: Dimensional data - MAC 093 (natural convection)

Available options

1 Power connection

The output direction of the electrical power connector is selected at the time the order is placed. Possible output directions are:

- to side A
- to side B
- to the right
- to the left

The drawing depicts side A as output direction. The dimensions of any other direction are obtained by a virtual turning of the connector housing around the Z axis.

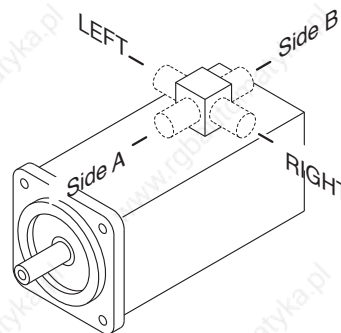

2 Motor version

- Tachofeedback and second shaft end

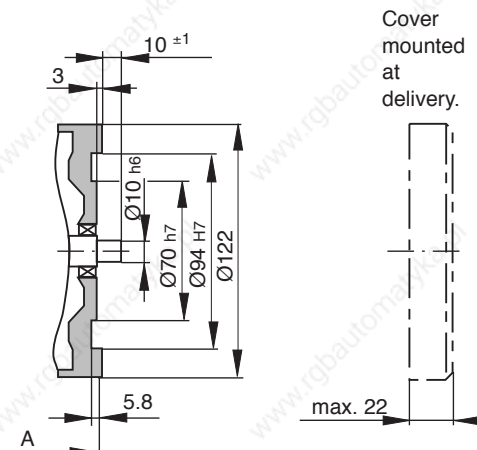
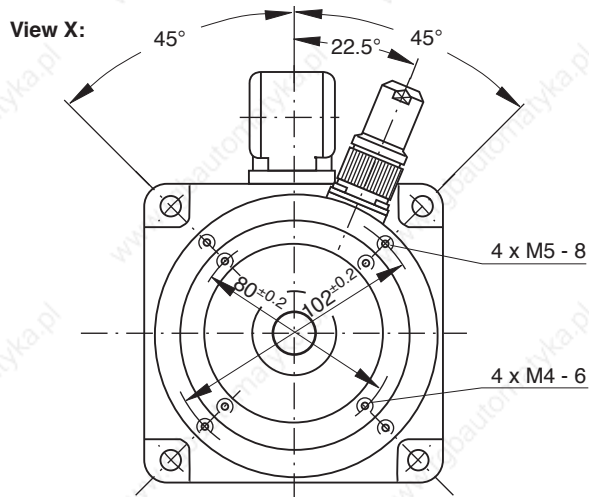

- Tachofeedback and mounted incremental encoder

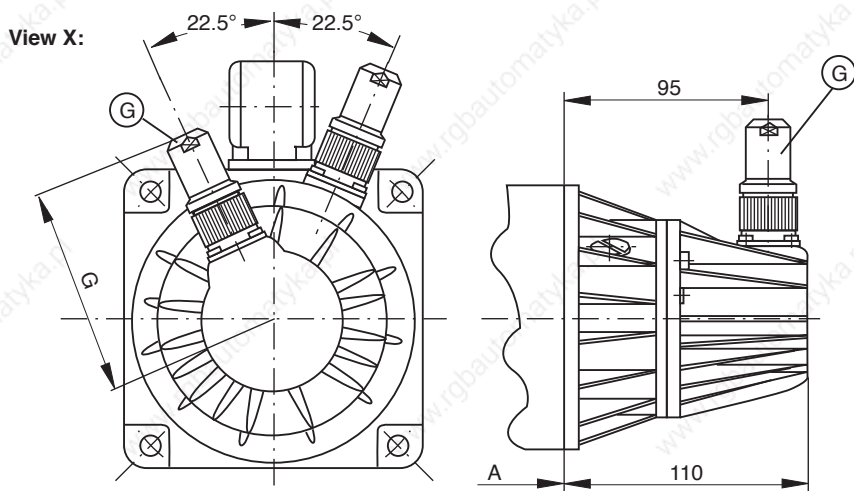

G Incremental encoder connector

Must be ordered separately.

Name	Conn. type	Dim. G
straight conn.	INS 301	88
	INS 101	90
angle conn.	INS 351	86
	INS 311	

- Tachofeedback and mounted absolute encoder (see following page)

MB093-0/2

Fig 6.14: Dimensional data - MAC 093 - available options - (natural convection)

Available options

- Tachofeedback and mounted absolute encoder

View X:

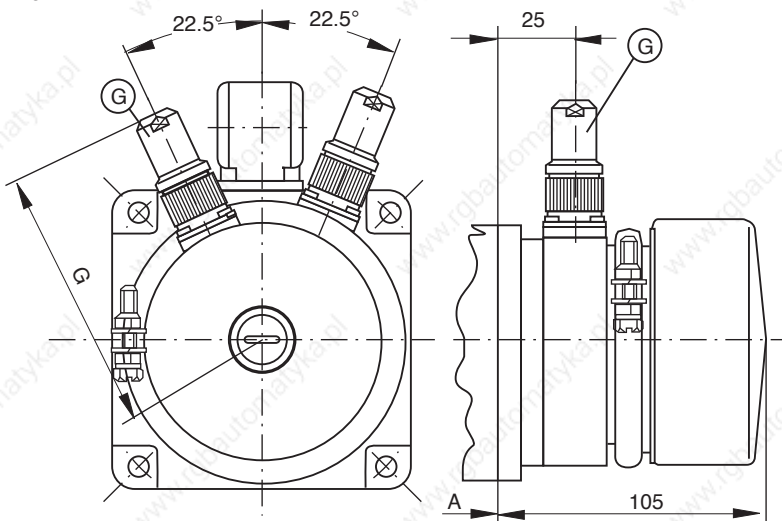

Ⓒ **Absolute encoder conn.**
Must be ordered separately.

Name	Conn. type	Dim. G
straight conn.	INS 326	104
	INS 92	106
angle conn.	INS 322	102

3 Blocking brake

- without blocking brake
Dim. A retained
- Standard blocking brake: 6.5 Nm
Dim. A. retained
- heavy-duty blocking brake: 14.0 Nm
- extra heavy-duty blocking brake: 22.0 Nm

Table for blocking brake with 14 and 22 Nm

Size	Dim. A
MAC 093 A	305
MAC 093 B	346
MAC 093 C	405

4 Output shaft

- plain shaft (recommended type)
- with keyway per DIN 6885 sh. 1, 8/68 edition
(Note! balanced with entire key.)

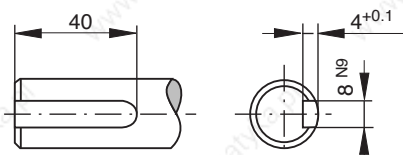

Matching key: DIN 6885-A 8 x 7 x 40
Must be ordered separately

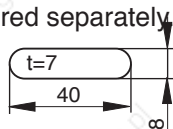

5 Special centering diameter

- $\varnothing 130 j6$

MB093-0/3

Fig 6.15: Dimensional data - MAC 093 - available options - (natural convection)

6.5. Dimensional data - radial cooling

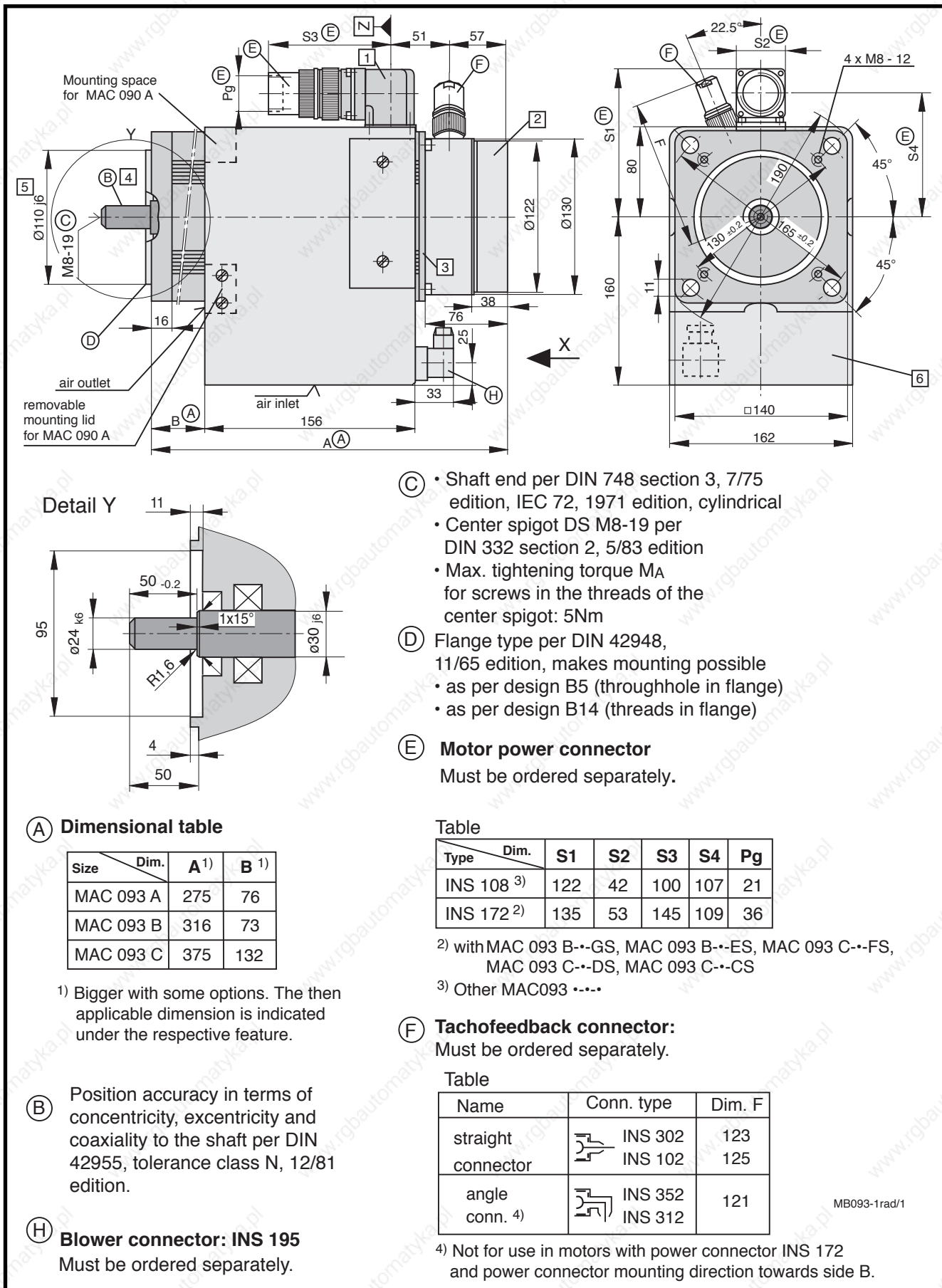

Fig 6.16: Dimensional data - MAC 093 (radial cooling)

Available options

1 Power connection

The output direction of the electrical power connector is selected at the time the order is placed. Possible output directions are:

- to side A
- to side B
- to the right
- to the left

The drawing depicts side A as output direction. The dimensions of any other direction are obtained by a virtual turning of the connector housing around the Z axis.

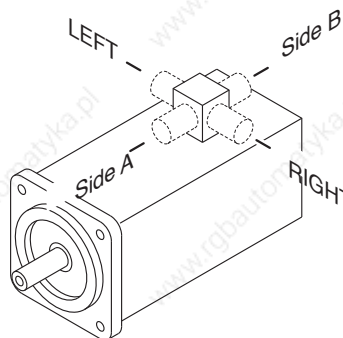

2 Motor version

- Tachofeedback and second shaft end

View X:

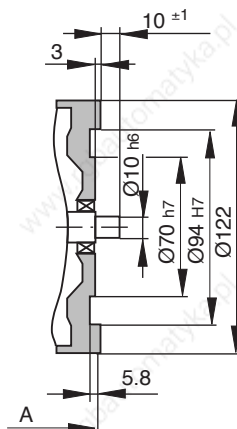
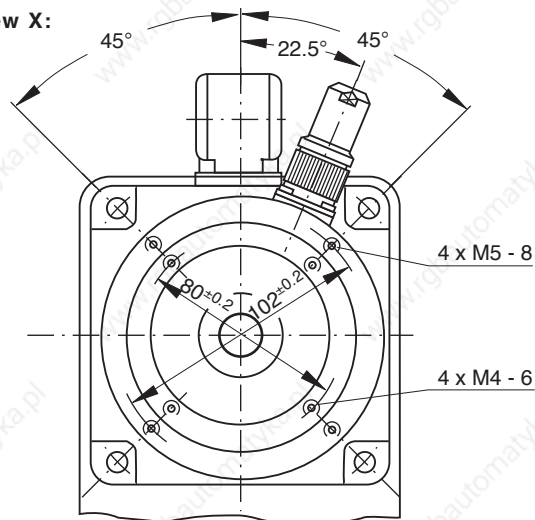

Cover mounted at delivery.

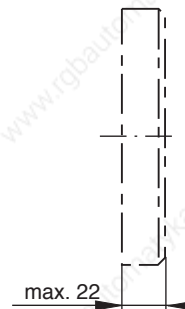

- Tachofeedback and mounted incremental encoder

View X:

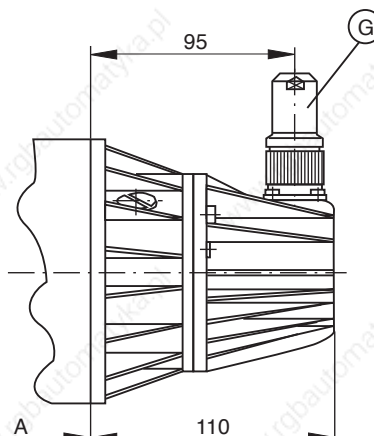
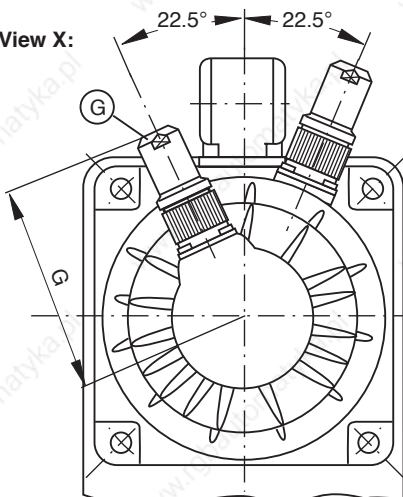

G Incremental encoder connector

Must be ordered separately.

Name	Conn. type	Dim. G
straight conn.	INS 301	88
	INS 101	90
angle conn.	INS 351 INS 311	86

- Tachofeedback and mounted absolute encoder (see following page)

MB090-1rad/2

Fig 6.17: Dimensional data - MAC 093 - available options - (radial cooling)

Available options

- Tachofeedback and mounted absolute encoder

View X:

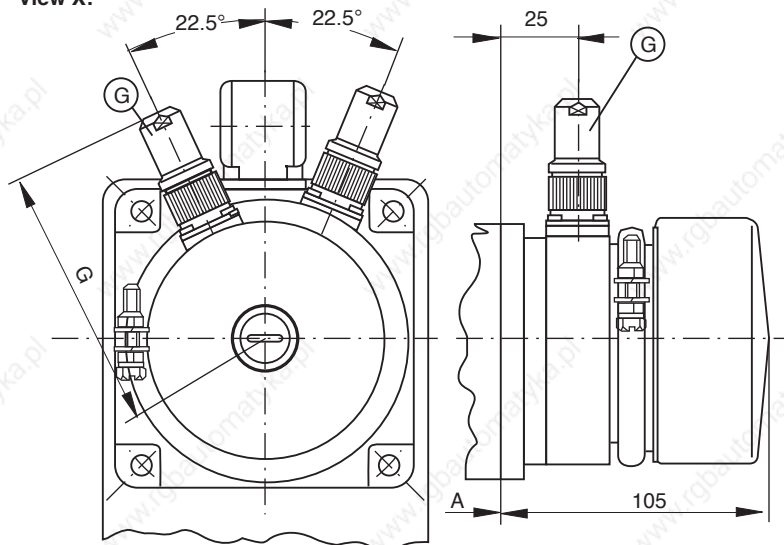

G Absolute encoder conn.
Must be ordered separately.

Name	Conn. type	Dim. G
straight conn.	INS 326	104
	INS 92	106
angle conn.	INS 322	102

3 Blocking brake

- without blocking brake
Dim. A and B retained
- Standard blocking brake: 6.5 Nm
Dim. A and B retained
- heavy-duty blocking brake: 14.0 Nm
- extra heavy-duty blocking brake: 22.0 Nm

Table for blocking brake with 14 and 22 Nm

Size \ Dim.	A	B
MAC 093 A	305	106
MAC 093 B	346	103
MAC 093 C	405	162

4 Output shaft

- plain shaft (recommended type)
- with keyway per DIN 6885 sh. 1, 8/68 edition
(Note! balanced with entire key.)

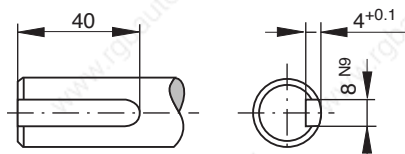

Matching key: DIN 6885-A 8 x 7 x 40
Must be ordered separately.

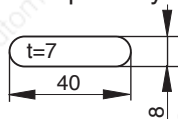

5 Special centering diameter

- $\varnothing 130 j6$

6 Blower arrangement

Looking towards motor shaft.

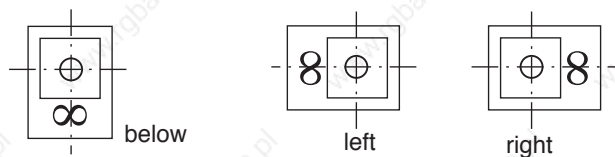

MB093-1rad/3

Fig 6.18: Dimensional data - MAC 093 - available options - (radial cooling)

6.6. Dimensional Data - Axial Cooling

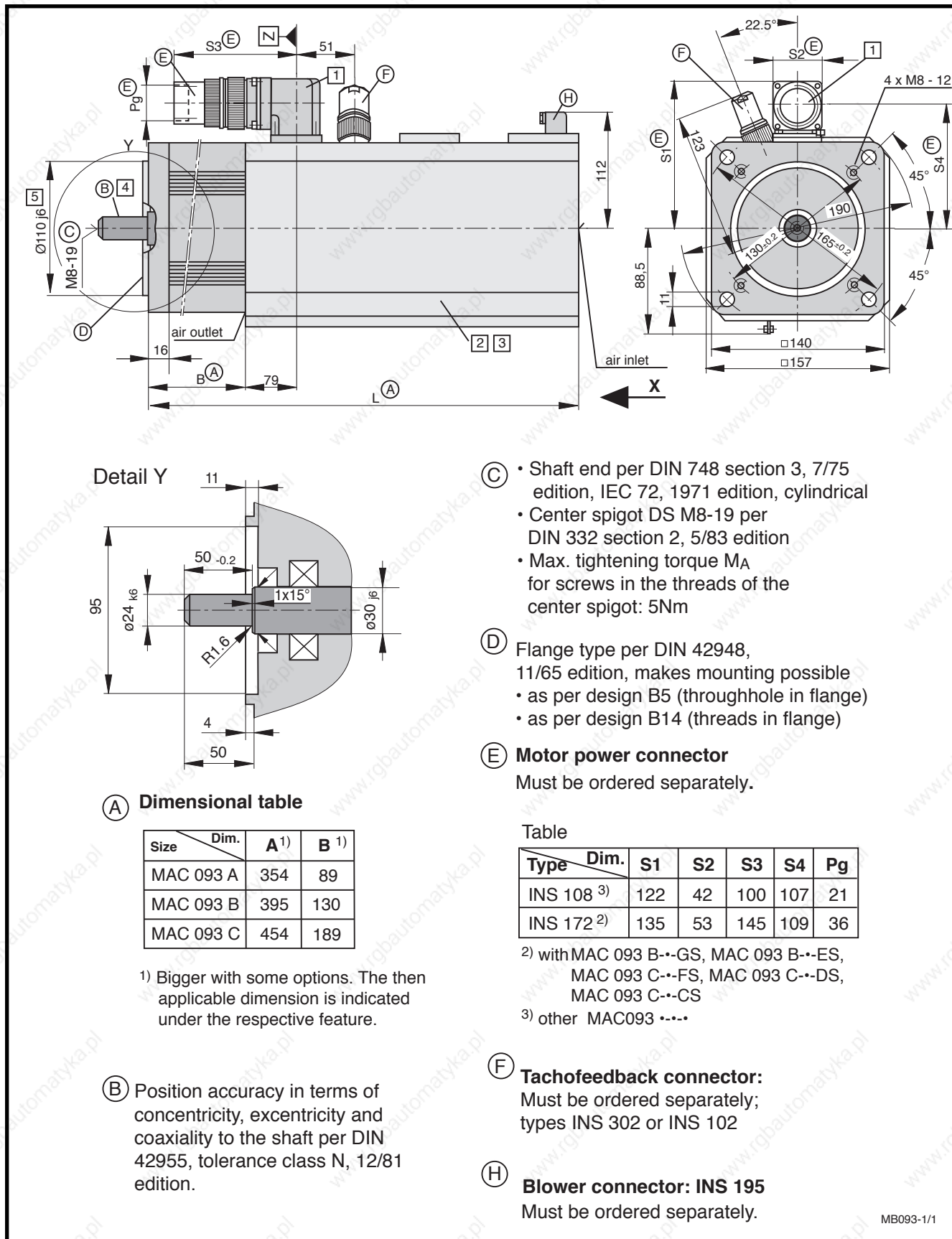

Fig 6.19: Dimensional data - MAC 093 (axial cooling)

Available options

1 Power connection

The output direction of the electrical power connector is selected at the time the order is placed. Possible output directions are:

- to side A
- to side B
- to the right
- to the left

The drawing depicts side A as output direction. The dimensions of any other direction are obtained by a virtual turning of the connector housing around the Z axis.

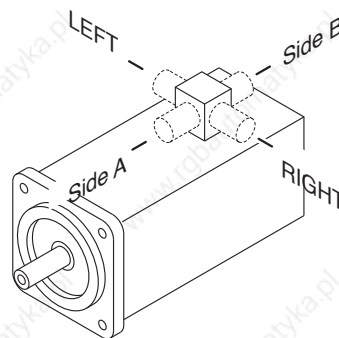

2 Motor version

- Tachofeedback and mounted incremental encoder

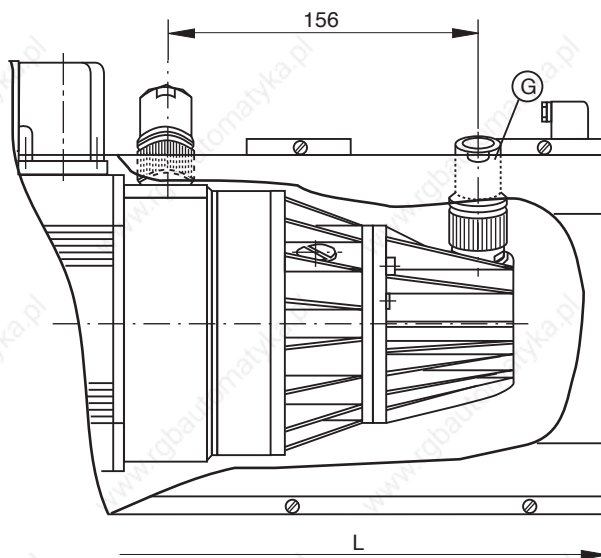
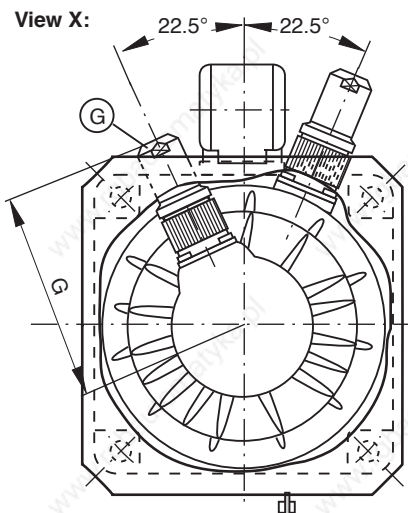

(G) Incremental encoder connector

Must be ordered separately.



Name	Conn. type	Dim. G
straight	 INS 301	123
conn.	 INS 101	125

Table:

Size	Dim.	L	B
MAC 093 A		454	89
MAC 093 B		495	130
MAC 093 C		554	189

MB093-1/2

Fig 6.20: Dimensional data - MAC 093 - available options - (axial cooling)

Available options

- Tachofeedback and mounted absolute encoder

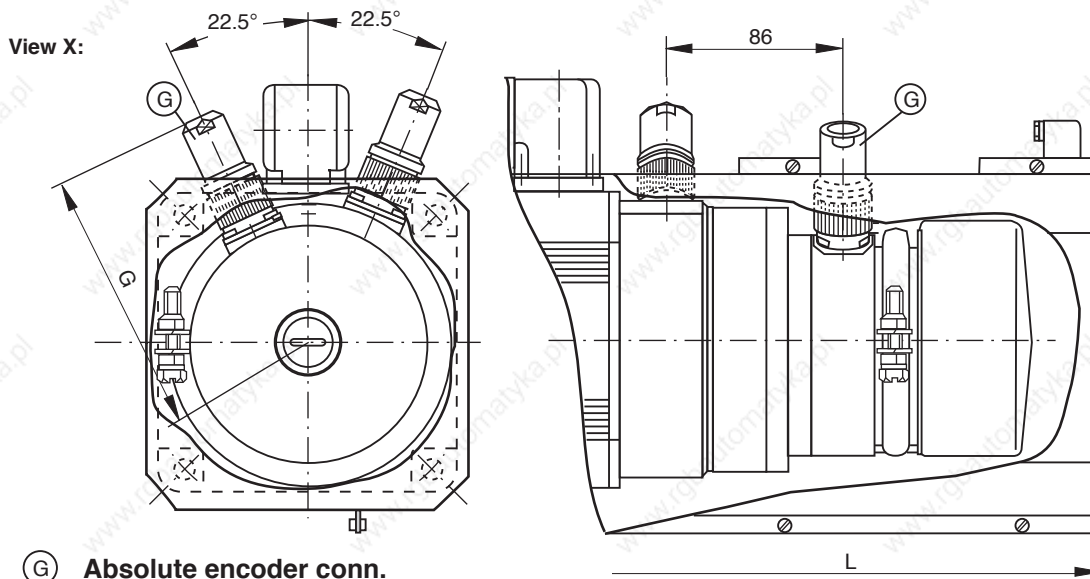

G Absolute encoder conn.
Must be ordered separately.

Name	Conn. type	Dim. G
straight conn.	INS 326	104
	INS 92	106

Size	Dim.	L	B
MAC 093 A		454	89
MAC 093 B		495	130
MAC 093 C		554	189

3 Blocking brake

- without blocking brake
Dim. L and B retained
- Standard blocking brake: 6.5 Nm
Dim. L and B retained
- heavy-duty blocking brake: 14.0 Nm
- extra heavy-duty blocking brake: 22.0 Nm

Table for blocking brake with 14 and 20 Nm

Size	Dim.		Vers. 4	
	L	B	L	B
MAC 093 A	384	119	484	119
MAC 093 B	425	160	525	160
MAC 093 C	484	219	584	219

Vers. 2 = Motor with tachofeedback
Vers. 4 = Motor with tachofeedback and mounted encoder

4 Output shaft

- plain shaft (recommended type)
- with keyway per DIN 6885 sh. 1, 8/68 edition
(Note! balanced with entire key.)

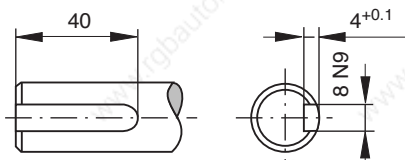

Matching key: DIN 6885-A 8 x 7 x 50
Must be ordered separately.

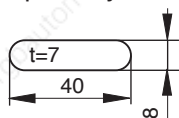

5 Special centering diameter

- Ø130 j6

MB093-1/3

Fig 6.21: Dimensional data - MAC 093 - available options - (axial cooling)

6.7. Available Options

Type code fields		Example:	MAC 093 A-0-LS-4 - C/110-A-0/WI 520LV/S000							
1. Motor for analogue drives	MAC									
2. Motor size	093									
3. Motor length	A, B, C									
4. Type of cooling:										
natural convection			surface cooling							
			axial				radial			
					blower right		blower below		blower left	
			AC	AC	AC	AC	AC	AC	AC	AC
			230 V	115 V	230 V	115 V	230 V	115 V	230 V	115 V
0			1 ¹⁾	2 ¹⁾	6	A	7	B	8	C
5. Type of windings			Motor length							
Nominal rpm		A		B		C				
2000 min ⁻¹		WS		OS		KS				
3000 min ⁻¹		PS		JS		FS				
4000 min ⁻¹		LS		GS		DS				
6000 min ⁻¹		HS		ES		CS				
6. Motor feedback										
Motor type										
with tachofeedback			2							
with tachofeedback and second shaft end			3							
with tachofeedback and mounted incremental or absolute encoder			4							
Tacho voltage										
set to nominal motor speed			-							
(nominal rpm > 3000 min ⁻¹)			: 1,5 V/1000 min ⁻¹)							
(nominal rpm ≤ 3000 min ⁻¹)			: 3 V/1000 min ⁻¹)							
1,5 V/1000 min ⁻¹			H							
Tacho type										
Standard			C							
increased smooth run quality			F							
7. Centering diameter										
for design B05 and B14			110							
for design B05 and B14			130							
8. Power connection										
connector to side A			A							
connector to side B			B							
connector to right (looking onto output shaft)			R							
connector to left (looking onto output shaft)			L							
9. Blocking brake										
without blocking brake			0							
with standard blocking brake (6.5 Nm)			1							
with heavy-duty blocking brake (14 Nm)			2							
with extra heavy-duty blocking brake (22 Nm)			3							
10. Type ²⁾										
Incremental encoder with standard mounting			WI							
Incremental encoder with shock-damped mounting			DI							
Absolute encoder			AM							
Mounted encoder										
11. Encoder code ²⁾										
For available types, see section 2.4 "Motor feedback"										
12. Special types										
Fixed and documented by INDRAMAT with special number (see Drawing no.: 106-0105-4301-XX)										
Does not apply to standard motors.										

1) For type 3 motors (with 2nd shaft end and tachofeedback).
Not available with axial surface cooling.

2) Type code fields 10 and 11 do not apply to motor types 2 and 3.

TLMAC093

Fig 6.22: Type codes - MAC 093

6.8. Special Options

Specification of Option	S005
with keyway per DIN 6885, sheet 1	X

Fig 6.23: Special options with a MAC 093

Empty page

7. MAC 112

7.1. Technical Data

Designation	Symbol	Unit	Motor type MAC ...			
			112 A - - - Z •	112 B - - - P •	112 C - - - K •	112 D - - - H •
Nominal motor speed ¹⁾	n	min ⁻¹	1500	1500	1500	1500
Continuous torque at standstill ²⁾	M _{dN}	Nm	10.7 (13.0) ⁵⁾	18.2 (29) ⁵⁾	28.0 (44.0) ⁵⁾	38.0 (57.0) ⁵⁾
Continuous current at standstill	I _{dN}	A	14.5 (17.2) ⁵⁾	21.0 (33.0) ⁵⁾	31.0 (49.0) ⁵⁾	42.0 (63) ⁵⁾
Rotor moment of inertia ³⁾	J _M	kgm ²	61 x 10 ⁻⁴	120 x 10 ⁻⁴	170 x 10 ⁻⁴	230 x 10 ⁻⁴
Torque constant at 20 °C	K _m	Nm/A	0.820	0.910	1.000	1.010
Windings resistance at 20 °C	R _A	Ohm	0.990	0.450	0.270	0.176
Windings inductance	L _A	mH	10.0	6.3	4.5	3.2
Maximum peak of pulse current	I _{peak}	A	54	97	141	195
Thermal time constant	T _{th}	min	100 (75) ⁵⁾	90 (60) ⁵⁾	100 (75) ⁵⁾	120 (90) ⁵⁾
Mass ⁴⁾	m _M	kg	25	36	48	59
			112 A - - - V •	112 B - - - L •	112 C - - - H •	112 D - - - F •
Nominal motor speed ¹⁾	n	min ⁻¹	2000	2000	2000	2000
Continuous torque at standstill ²⁾	M _{dN}	Nm	10.5 (13.0) ⁵⁾	17.5 (29) ⁵⁾	27.0 (44.0) ⁵⁾	38.0 (57.0) ⁵⁾
Continuous current at standstill	I _{dN}	A	18.5 (22.9) ⁵⁾	26.3 (43.5) ⁵⁾	41.0 (67.0) ⁵⁾	56.0 (83) ⁵⁾
Rotor moment of inertia ³⁾	J _M	kgm ²	61 x 10 ⁻⁴	120 x 10 ⁻⁴	170 x 10 ⁻⁴	230 x 10 ⁻⁴
Torque constant at 20 °C	K _m	Nm/A	0.630	0.740	0.730	0.760
Windings resistance at 20 °C	R _A	Ohm	0.650	0.260	0.150	0.110
Windings inductance	L _A	mH	6.0	3.5	2.5	1.8
Maximum peak of pulse current	I _{peak}	A	71	130	195	260
Thermal time constant	T _{th}	min	100 (75) ⁵⁾	90 (60) ⁵⁾	100 (75) ⁵⁾	120 (90) ⁵⁾
Mass ⁴⁾	m _M	kg	25	36	48	59
			112 A - - - L •	112 B - - - G •	112 C - - - E •	112 D - - - E •
Nominal motor speed ¹⁾	n	min ⁻¹	3000	3000	3000	3000
Continuous torque at standstill ²⁾	M _{dN}	Nm	9.8 (13.0) ⁵⁾	16.0 (29) ⁵⁾	24.0 (44.0) ⁵⁾	35.0 (57.0) ⁵⁾
Continuous current at standstill	I _{dN}	A	31.0 (41.3) ⁵⁾	41.0 (75.0) ⁵⁾	57.0 (104) ⁵⁾	63.0 (102) ⁵⁾
Rotor moment of inertia ³⁾	J _M	kgm ²	61 x 10 ⁻⁴	120 x 10 ⁻⁴	170 x 10 ⁻⁴	230 x 10 ⁻⁴
Torque constant at 20 °C	K _m	Nm/A	0.350	0.430	0.470	0.620
Windings resistance at 20 °C	R _A	Ohm	0.180	0.090	0.060	0.070
Windings inductance	L _A	mH	1.9	1.2	1.0	1.3
Maximum peak of pulse current	I _{peak}	A	130	223	312	312
Thermal time constant	T _{th}	min	100 (75) ⁵⁾	90 (60) ⁵⁾	100 (75) ⁵⁾	120 (90) ⁵⁾
Mass ⁴⁾	m _M	kg	25	36	48	59
					112 C - - - C •	
Nominal motor speed ¹⁾	n	min ⁻¹			5000	
Continuous torque at standstill ²⁾	M _{dN}	Nm			27.0	
Continuous current at standstill	I _{dN}	A			87.5	
Rotor moment of inertia ³⁾	J _M	kgm ²			170 x 10 ⁻⁴	
Torque constant at 20 °C	K _m	Nm/A			0.330	
Windings resistance at 20 °C	R _A	Ohm			0.030	
Windings inductance	L _A	mH			0.5	
Maximum peak of pulse current	I _{peak}	A			400	
Thermal time constant	T _{th}	min			100	
Mass ⁴⁾	m _M	kg			48	

1) The usable motor speed is determined by the drive used.
Only those usable speeds n_{max} found in the selection lists of the motor-drive combinations are binding.

2) With 60K overtemperature at the motor housing.
Continuous torque can be limited by the drive. See selection data.

3) With tacho-generator, without holding brake

4) With tacho-generator, without holding brake, without blower.

5) Parenthetical values apply to versions with surface cooling.

Fig 7.1: Type-dependent motor data

Designation	Symbol	Unit	Data		
Permissible ambient temperature	T_{um}	°C	0 ... + 45		
Permissible storage and transport temperature	T_L	°C	-20 ... +80		
Maximum installation elevation		m	1000 m. above sea level		
Protection category			IP 65		
Insulation classification			F		
Housing coat			Black prime coat (RAL9005)		
Voltage constant of the tachogenerator ¹⁾	C_w	Vs/rad V/min ⁻¹	0.0143 1.5/1000	0.0286 3/1000	0.0572 6/1000 ²⁾

¹⁾ Tachovoltage can be selected application-related.
²⁾ If 6 V/1000 min⁻¹ tachometer is used, then usable speed is limited to 1600 min⁻¹.

Fig 7.2: General data MAC 112

Designation	Symbol	Unit	Data holding brake		
			Standard	heavy-duty ¹⁾ electrically released	extra heavy-duty ¹⁾
Principle of action					
Holding torque	M_H	Nm		40	
Nominal voltage	U_N	V	14	DC 24 ± 10%	60
Nominal current	I_N	A	0.75	1.35	1.35
Moment of inertia	J_B	kgm ²	3.6×10^{-4}	32×10^{-4}	32×10^{-4}
Release delay	t_L	ms	70	150	150
Clamping delay	t_K	ms	30	30	30
Mass	m_B	kg	1.1	3.5	3.5

¹⁾ Not available with MAC 112A .

Fig 7.3: Technical data - holding brake

Designation	Symbol	Unit	Axial cooling	Radial cooling
Power consumption	S_N	VA	40/42	40/42
Nominal voltage	U_N	V	AC 230 or 115 ¹⁾	AC 230 or 115 ¹⁾
Frequency	f	Hz	50/60	50/60
Mass	m_L	kg	approx.. 3.3 ²⁾	approx.. 3.2 ²⁾
Protection category blower unit			IP 24	IP 24
Protection category blower motor			IP 44	IP 44

¹⁾ 115 V special design
²⁾ Blower shroud for motor with tacho feedback.

Fig 7.4: Technical data - surface cooling

7.2. Torque-Speed Characteristics

MAC 112 A - - - Z •
1500 min⁻¹

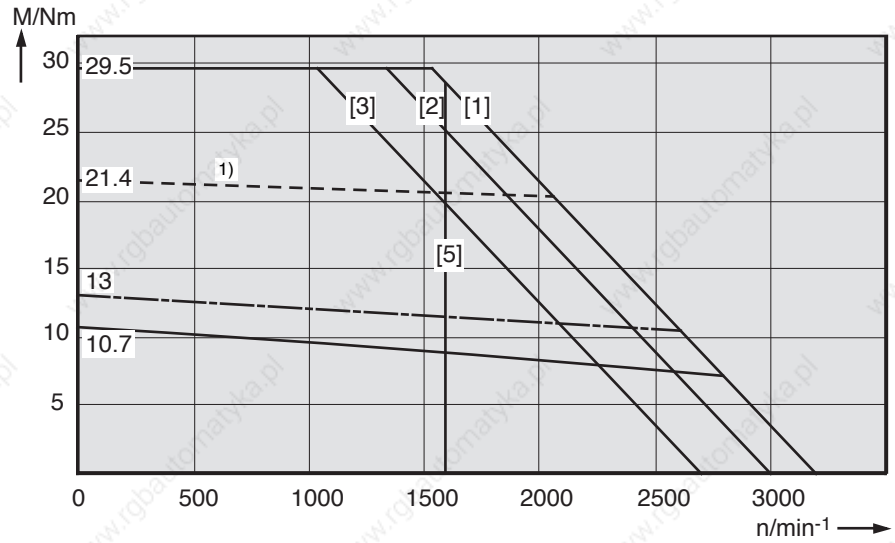

MAC 112 A - - - V •
2000 min⁻¹

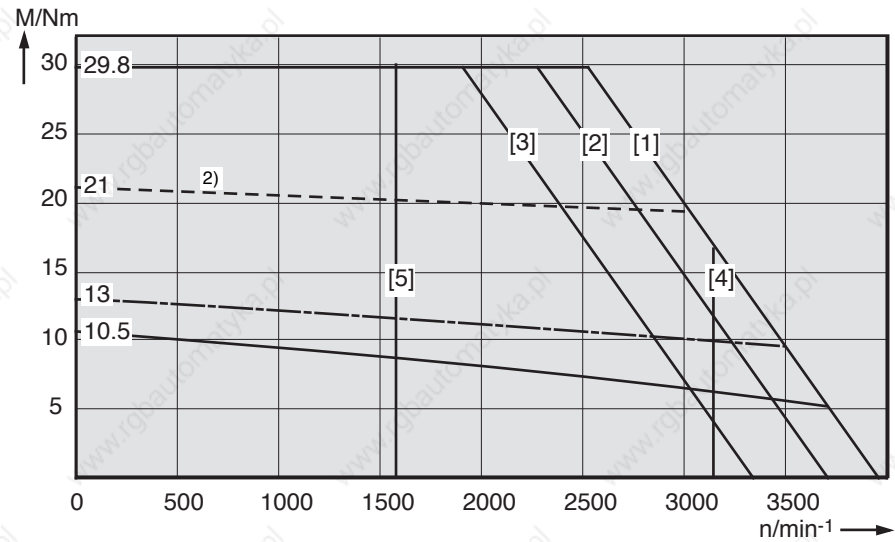

MAC 112 A - - - L •
3000 min⁻¹

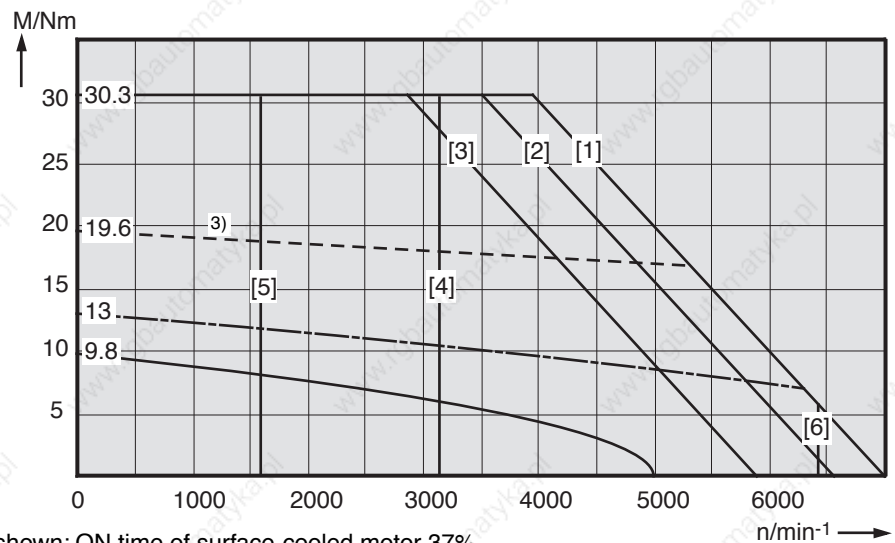

- 1) shown: ON time of surface-cooled motor 37%
- 2) shown: ON time of surface-cooled motor 38%
- 3) shown: ON time of surface-cooled motor 44%

Fig 7.5: Torque-speed characteristics MAC 112

MAC 112 B - - - P •
1500 min⁻¹

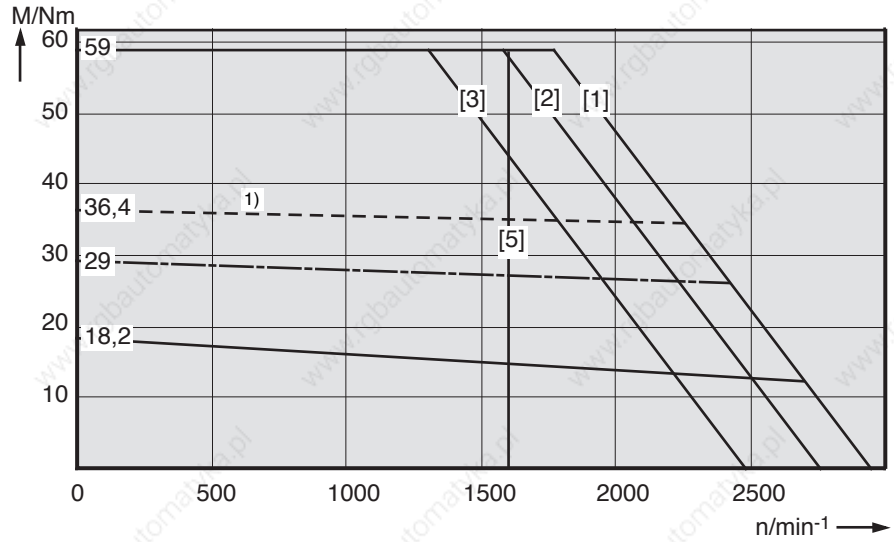

MAC 112 B - - - L •
2000 min⁻¹

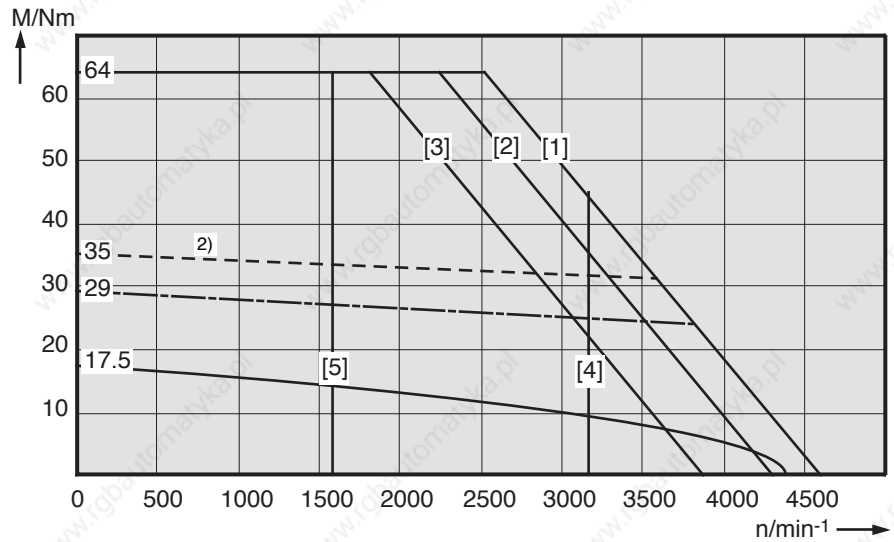

MAC 112 B - - - G •
3000 min⁻¹

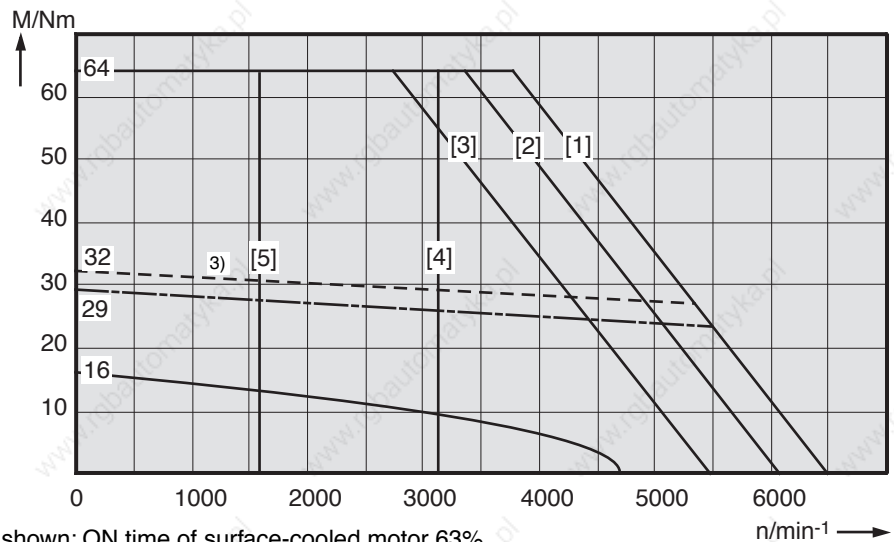

- 1) shown: ON time of surface-cooled motor 63%
- 2) shown: ON time of surface-cooled motor 69%
- 3) shown: ON time of surface-cooled motor 82%

Fig 7.6: Torque-speed characteristics MAC 112

MAC 112 C - - - K •
1500 min⁻¹

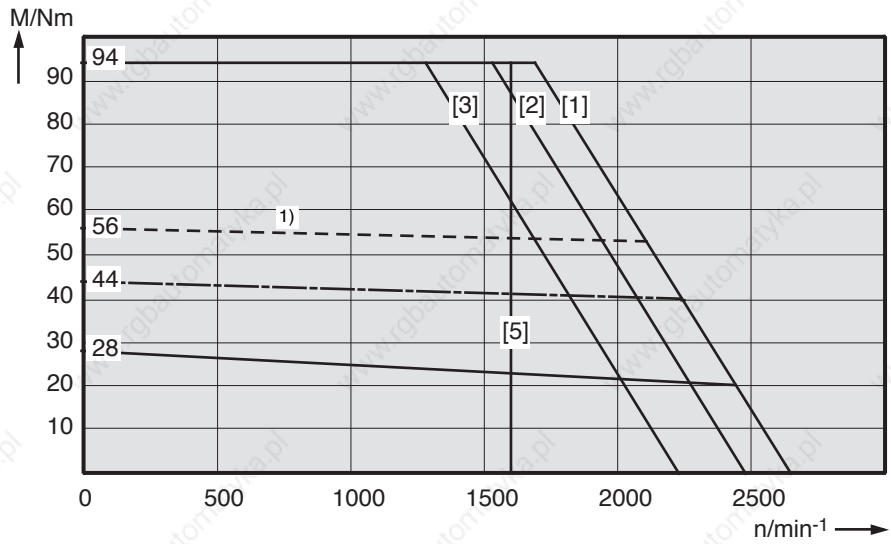

MAC 112 C - - - H •
2000 min⁻¹

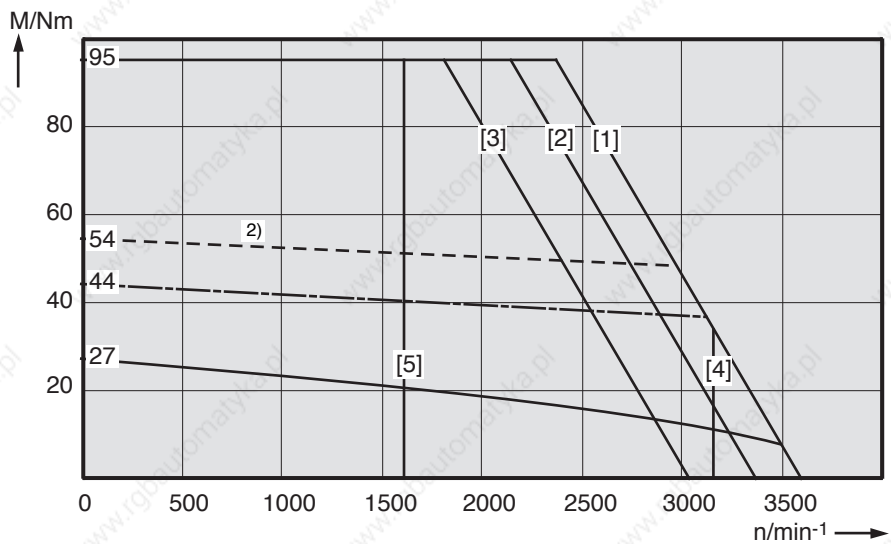

1) shown: ON time of surface-cooled motor 62%
2) shown: ON time of surface-cooled motor 66%

Fig 7.7: Torque-speed characteristics MAC 112

MAC 112 C - - - E •
3000 min⁻¹

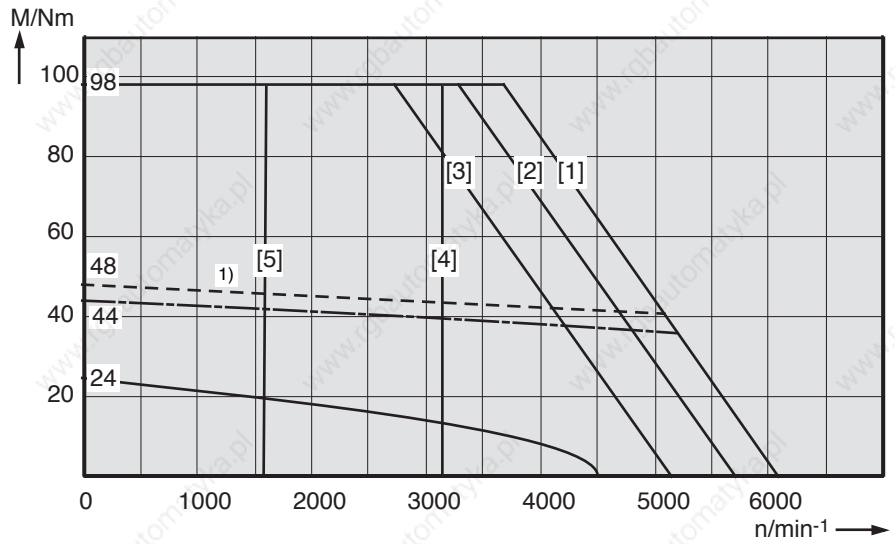

MAC 112 C - - - C •
5000 min⁻¹

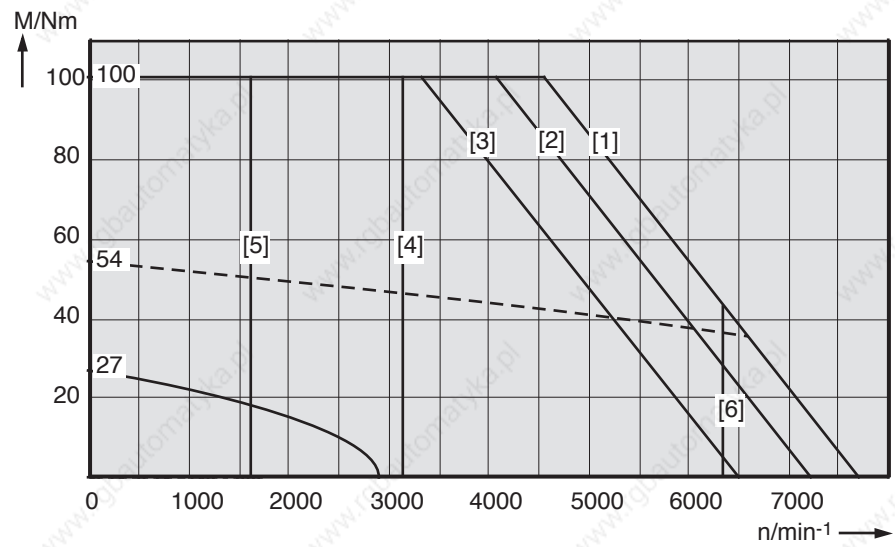

1) shown: ON time of surface-cooled motor 87%

Fig 7.8: Torque-speed characteristics MAC 112

MAC 112 D - - - H •
1500 min⁻¹

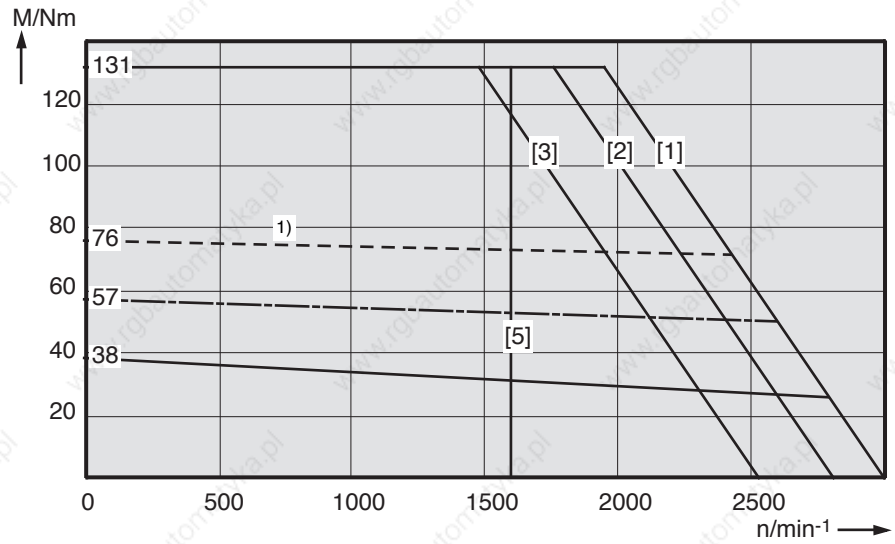

MAC 112 D - - - F •
2000 min⁻¹

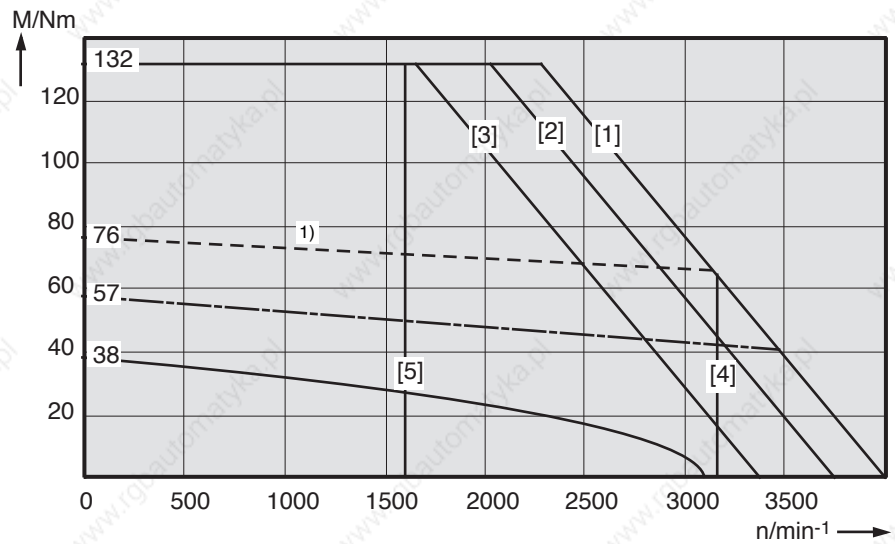

MAC 112 D - - - E •
3000 min⁻¹

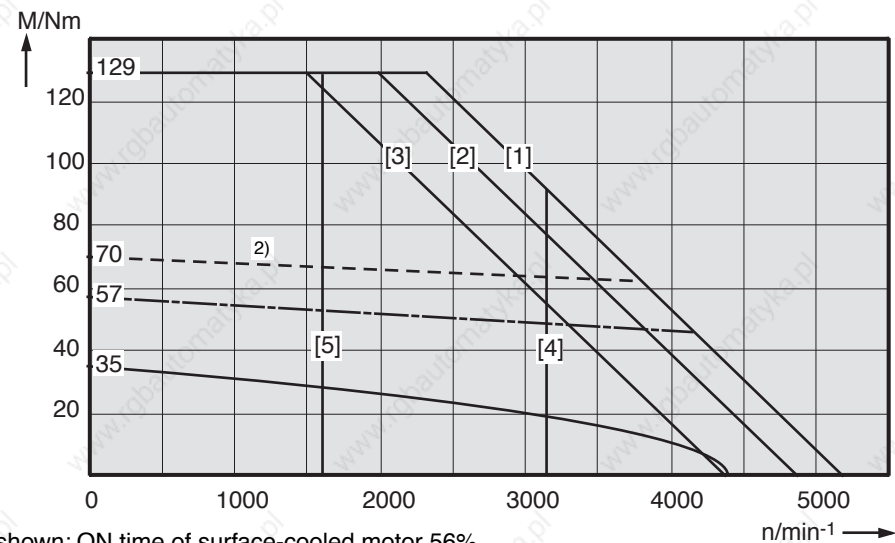

1) shown: ON time of surface-cooled motor 56%
2) shown: ON time of surface-cooled motor 66%

Fig 7.9: Torque-speed characteristics MAC 112

7.3. Shaft load capacity

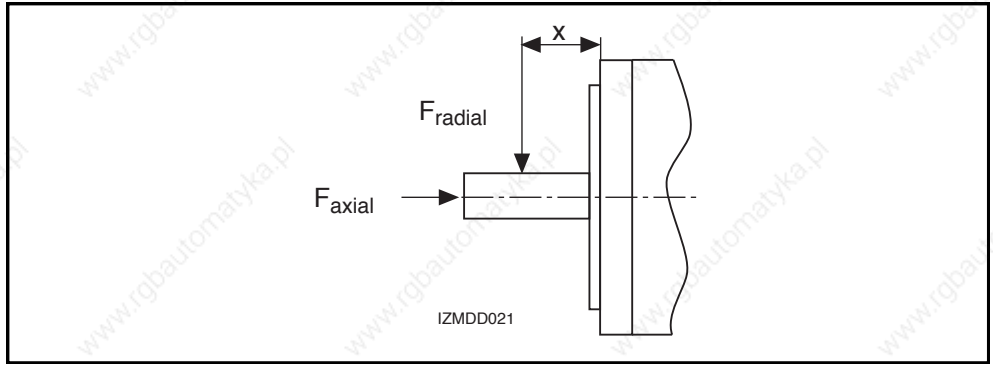

Fig 7.10: Shaft load

Permissible radial force
 F_{radial}

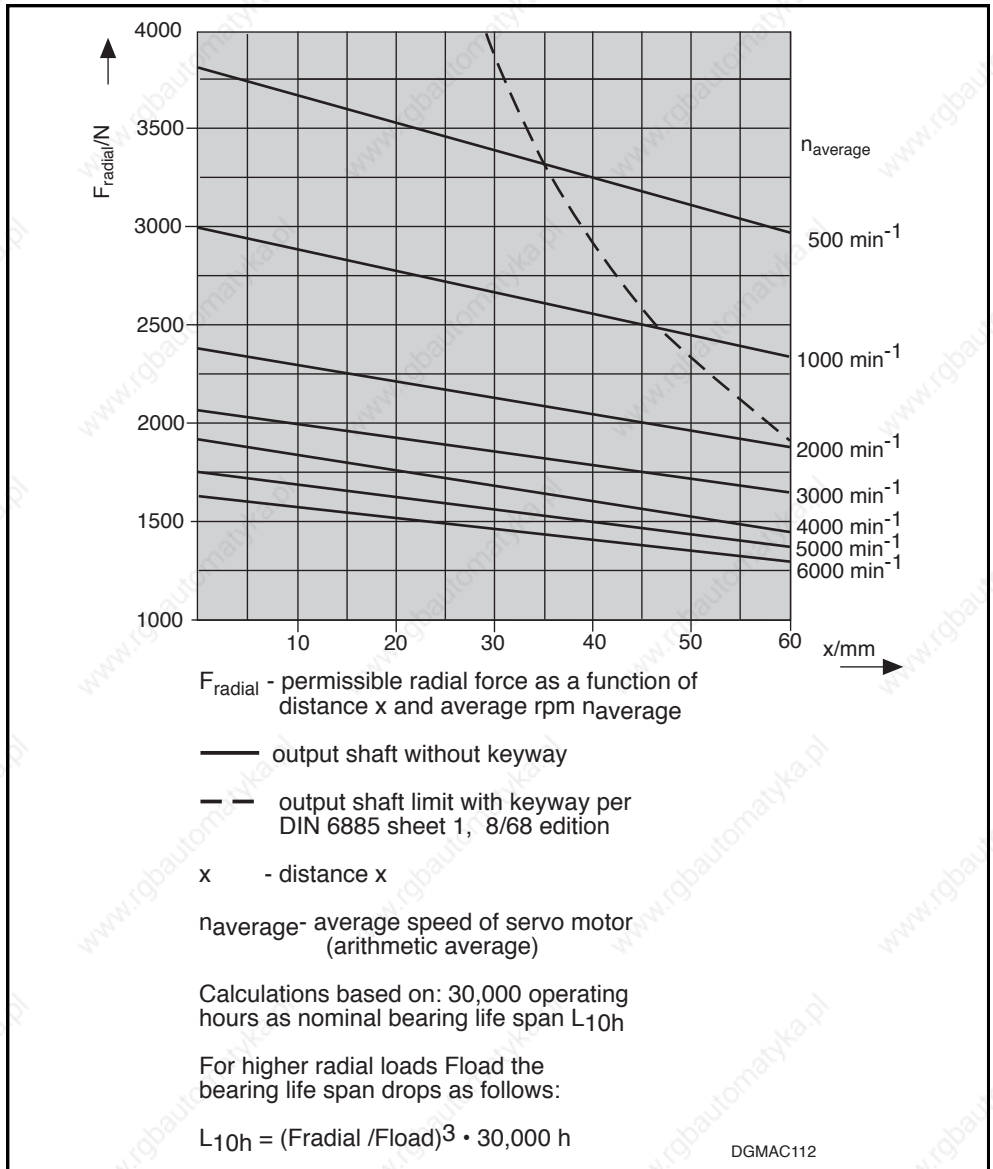

Fig 7.11: Permissible radial force

Permissible axial force
 F_{axial}

$$F_{axial} = 0.35 \cdot F_{radial}$$

F_{axial} - Permissible axial force

F_{radial} - Permissible radial force

7.4. Dimensional data - natural convection

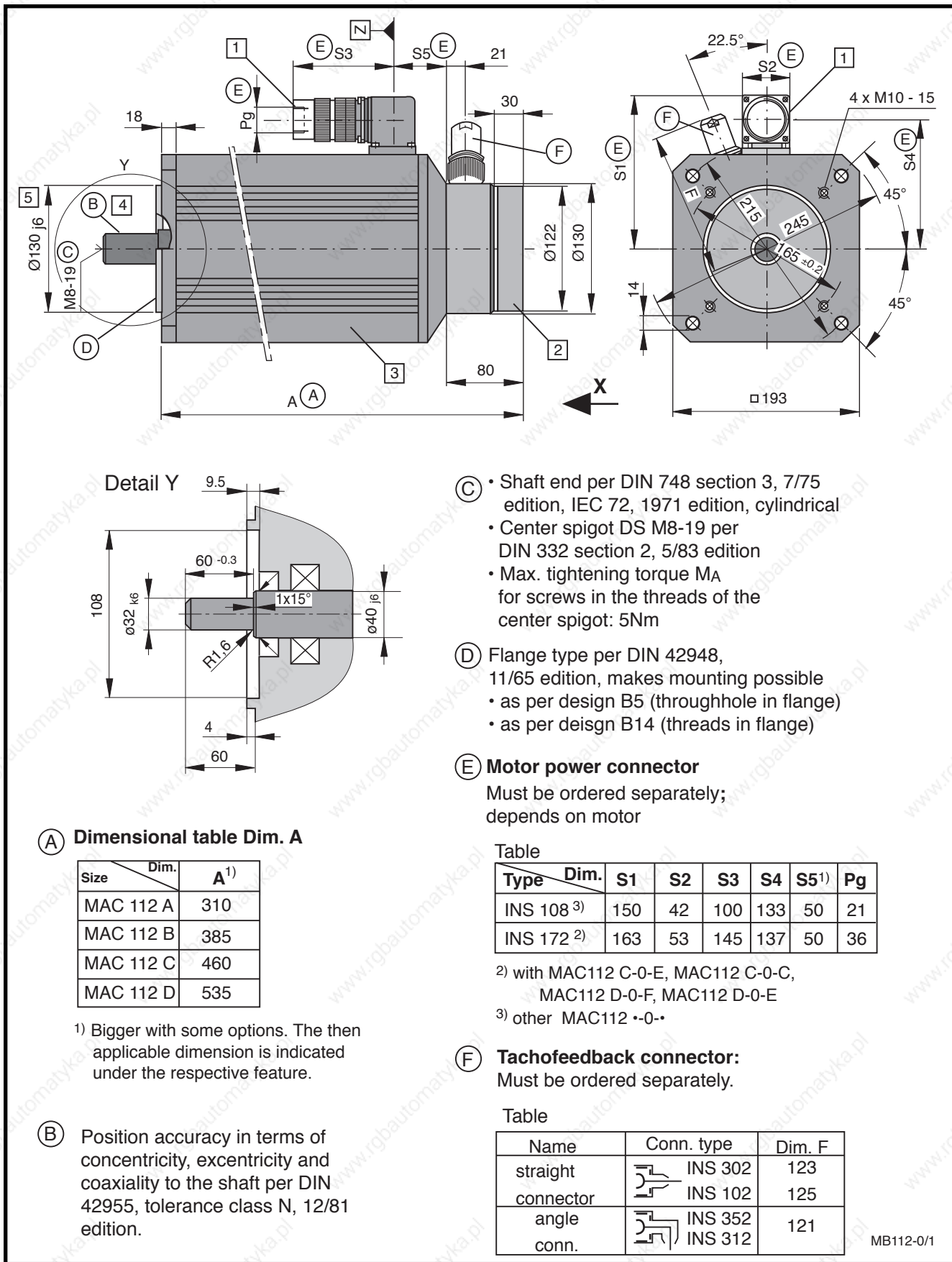

Fig 7.12: Dimensional data - MAC 112 (natural convection)

Available options

1 Power connection

The output direction of the electrical power connector is selected at the time the order is placed. Possible output directions are:

- to side A
- to side B
- to the right
- to the left

The drawing depicts side A as output direction. The dimensions of any other direction are obtained by a virtual turning of the connector housing around the Z axis.

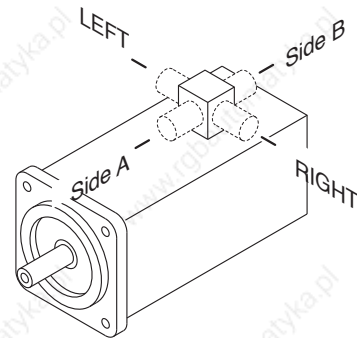

2 Motor version

- Tachofeedback and second shaft end

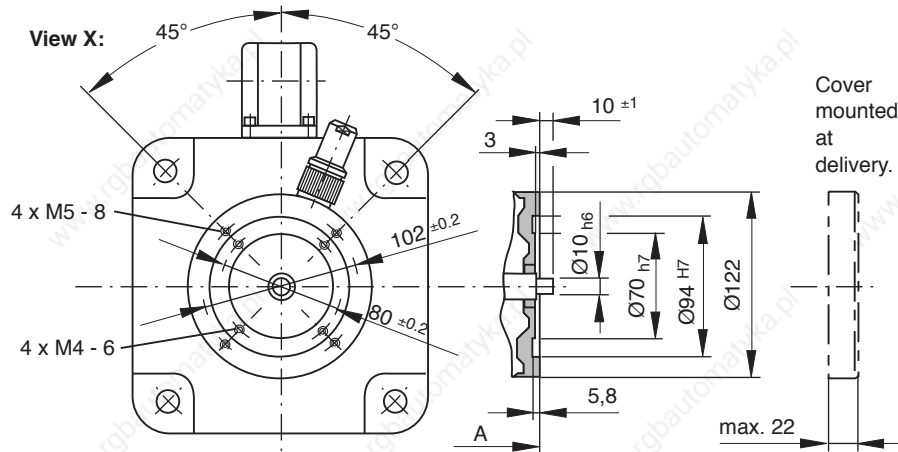

- Tachofeedback and mounted incremental encoder

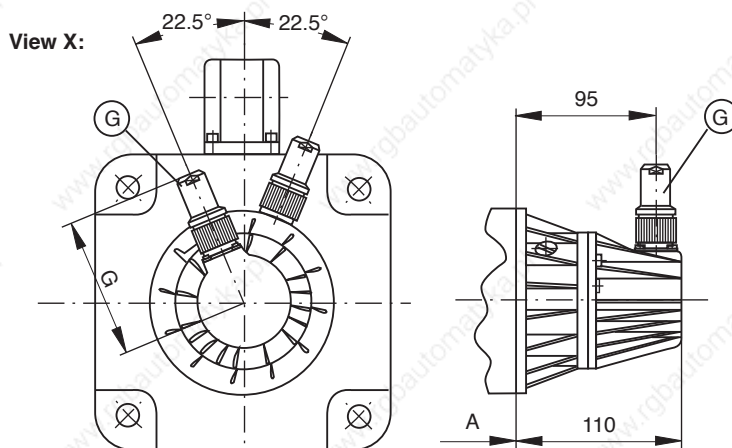

G Incremental encoder connector

Must be ordered separately.

Name	Conn. type	Dim. G
straight conn.	INS 301	88
	INS 101	90
angle conn.	INS 351 INS 311	86

- Tachofeedback and mounted absolute encoder (see following page)

MB112-0/2

Fig 7.13: Dimensional data - MAC 112 - available options - (natural convection)

Available options

- Tachofeedback and mounted absolute encoder

View X:

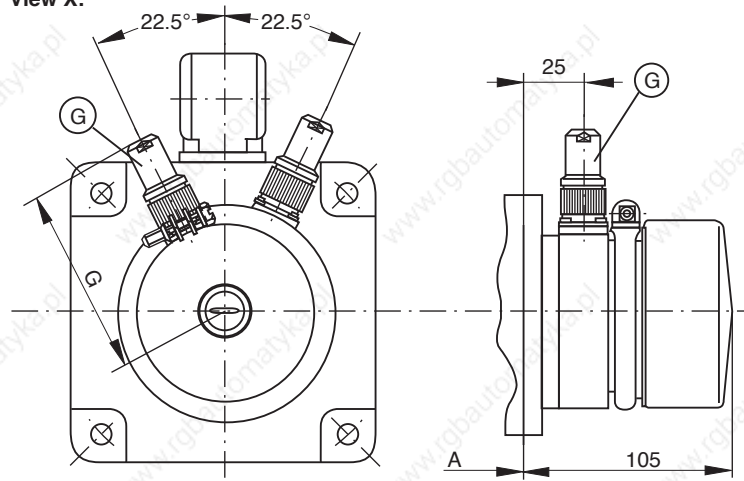

G Absolute encoder conn.
Must be ordered separately.

Name	Conn. type	Dim. G
straight conn.	INS 326	104
	INS 92	106
angle conn.	INS 322	102

3 Blocking brake

- without blocking brake
Dim. A and S5 retained
- Standard blocking brake: 14 Nm
Dim. A and S5 retained
- heavy-duty blocking brake: 40 Nm
(not available with MAC 112 A ...)
- extra heavy-duty blocking brake: 60 Nm
(not available with MAC 112 A ...)

Table for blocking brake
with 40 and 60 Nm

Size	Dim.	A	S5
MAC 112 B		435	98
MAC 112 C		510	98
MAC 112 D		585	98

4 Output shaft

- plain shaft (recommended type)
- with keyway per DIN 6885 sh. 1, 8/68 edition
(Note! balanced with entire key.)

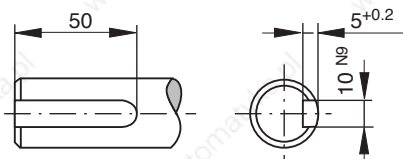

Matching key: DIN 6885-A 10 x 8 x 40
Must be ordered separately.

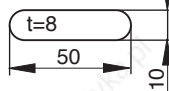

5 Special centering diameter

- $\varnothing 180 \text{ j6}$

MB112-0/3

Fig 7.14: Dimensional data - MAC 112 - available options - (natural convection)

7.5. Dimensional data - radial cooling

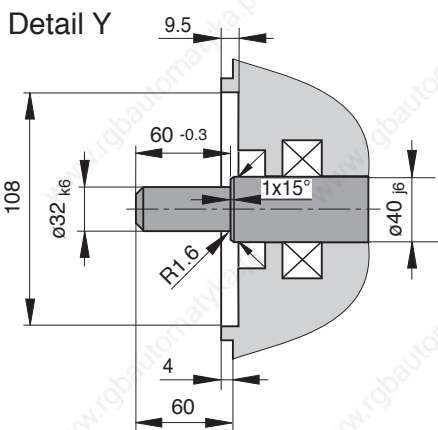
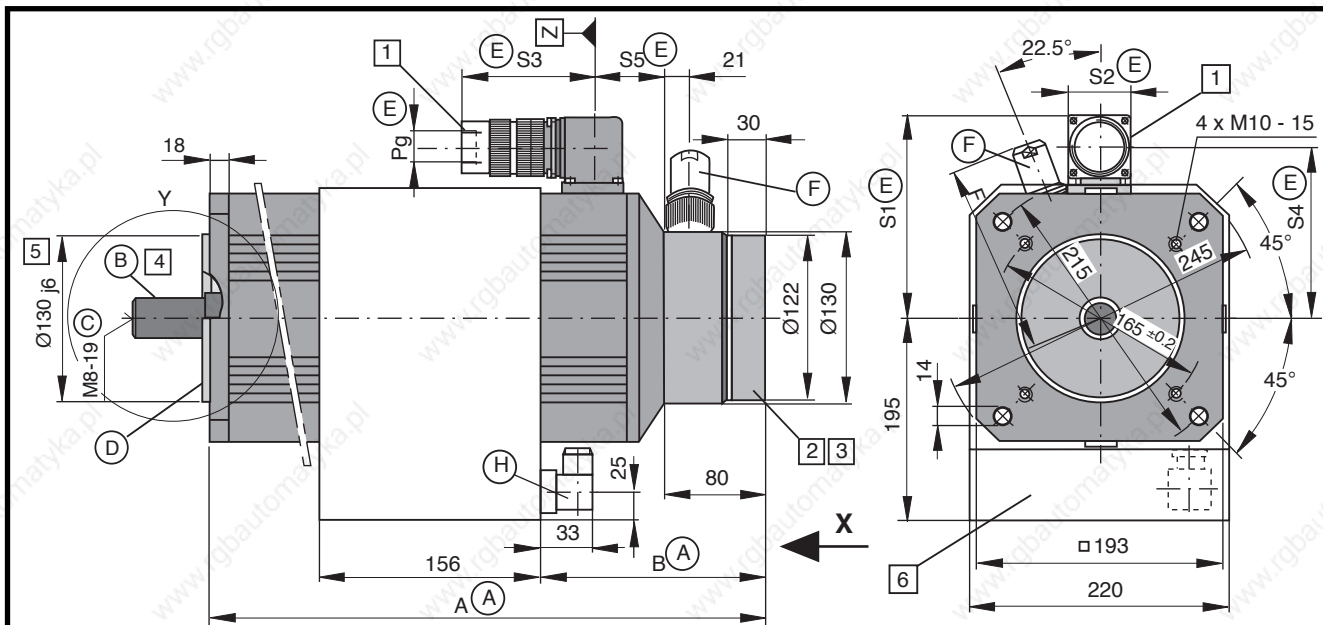

- (C) • Shaft end per DIN 748 section 3, 7/75 edition, IEC 72, 1971 edition, cylindrical
- Center spigot DS M8-19 per DIN 332 section 2, 5/83 edition
- Max. tightening torque MA for screws in the threads of the center spigot: 5 Nm
- (D) Flange type per DIN 42948, 11/65 edition, makes mounting possible
 - as per design B5 (throughhole in flange)
 - as per design B14 (threads in flange)
- (E) **Motor power connector**
Must be ordered separately.

(A) Dimensional table Dim. A and B

Size	Dim.	A ¹⁾	B ¹⁾
MAC 112 A		310	110
MAC 112 B		385	110
MAC 112 C		460	205
MAC 112 D		535	205

¹⁾ Bigger with some options. The then applicable dimension is indicated under the respective feature.

(B) Position accuracy in terms of concentricity, excentricity and coaxiality to the shaft per DIN 42955, tolerance class N, 12/81 edition.

Table

Type	Dim.	S1	S2	S3	S4	S5 ¹⁾	Pg
INS 108 ²⁾		150	42	100	133	50	21
INS 172 ³⁾		163	53	145	137	50	36

²⁾ with MAC112 A--Z, MAC112 A--V, MAC112 A--C, MAC112 B--P, MAC112 B--L

³⁾ other MAC112

(F) **Tachofeedback connector:**
Must be ordered separately.

Table

Name	Conn. type	Dim. F
straight connector	INS 302	123
angle conn.	INS 352 INS 312	121

(H) **Blower connector: INS 195**
Must be ordered separately.

MB112-1rad/1

Fig 7.15: Dimensional data - MAC 112 (radial cooling)

Available options

1 Power connection

The output direction of the electrical power connector is selected at the time the order is placed. Possible output directions are:

- to side A
- to side B
- to the right
- to the left

The drawing depicts side A as output direction. The dimensions of any other direction are obtained by a virtual turning of the connector housing around the Z axis.

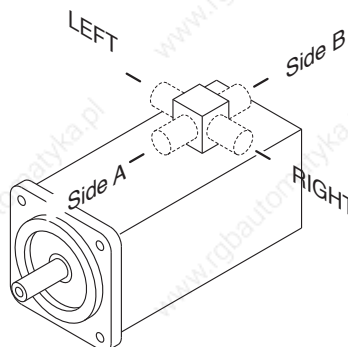

2 Motor version

- Tachofeedback and second shaft end

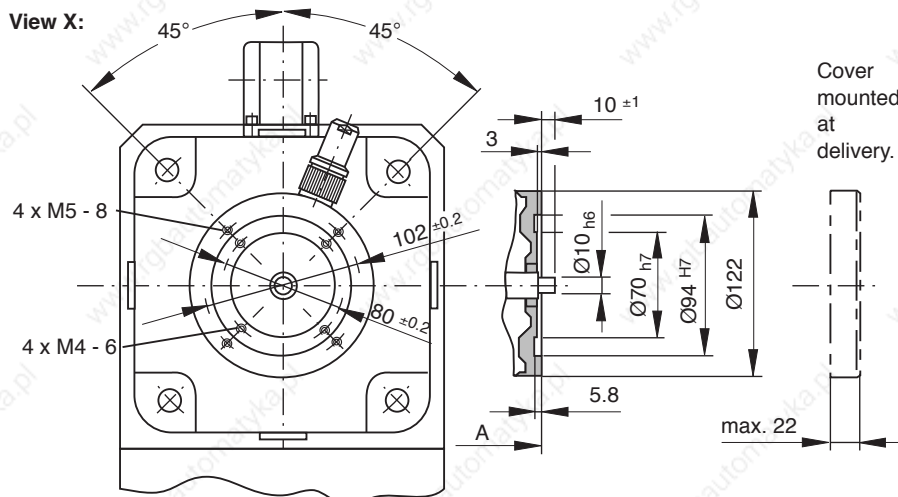

- Tachofeedback and mounted incremental encoder

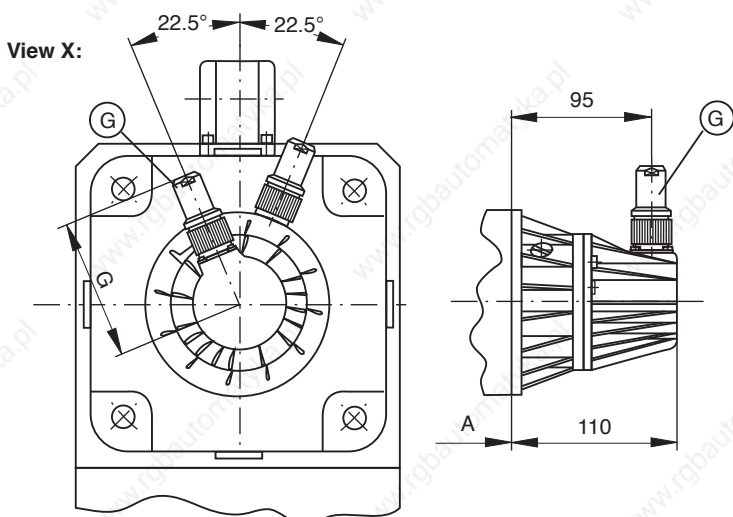

G Incremental encoder connector

Must be ordered separately.

Name	Conn. type	Dim. G
straight conn.	INS 301	88
	INS 101	90
angle conn.	INS 351 INS 311	86

- Tachofeedback and mounted absolute encoder (see following page)

MB112-1rad/2

Fig 7.16: Dimensional data - MAC 112 - available options - (radial cooling)

Available options

- Tachofeedback and mounted absolute encoder

View X:

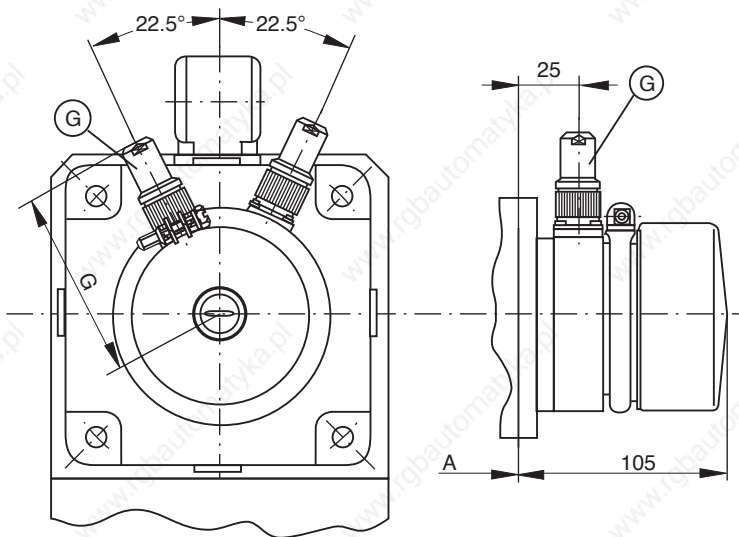

G Absolute encoder conn.
Must be ordered separately.

Name	Conn. type	Dim. G
straight conn.	INS 326	104
	INS 92	106
angle conn.	INS 322	102

3 Blocking brake

- without blocking brake
Dim. A, B and S5 retained
- Standard blocking brake: 14 Nm
Dim. A, B and S5 retained
- heavy-duty blocking brake: 40 Nm
(not available with MAC 112 A ...)
- extra heavy-duty blocking brake: 60 Nm
(not available with MAC 112 A ...)

Table for blocking brake with 40 and 60 Nm

Size \ Dim.	A	S5	B
MAC 112 B	435	98	160
MAC 112 C	510	98	255
MAC 112 D	585	98	255

4 Output shaft

- plain shaft (recommended type)
- with keyway per DIN 6885 sh. 1, 8/68 edition
(Note! balanced with entire key.)

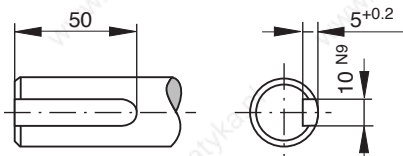

Matching key: DIN 6885-A 10 x 8 x 50
Must be ordered separately.

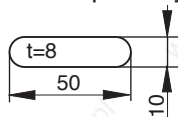

5 Special centering diameter

- $\varnothing 180 j6$

6 Blower arrangement

Looking towards motor shaft.

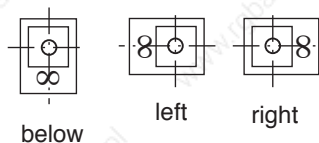

MB112-1rad/3

Fig 7.17: Dimensional data - MAC 112 - available options - (radial cooling)

7.6. Dimensional data - axial cooling

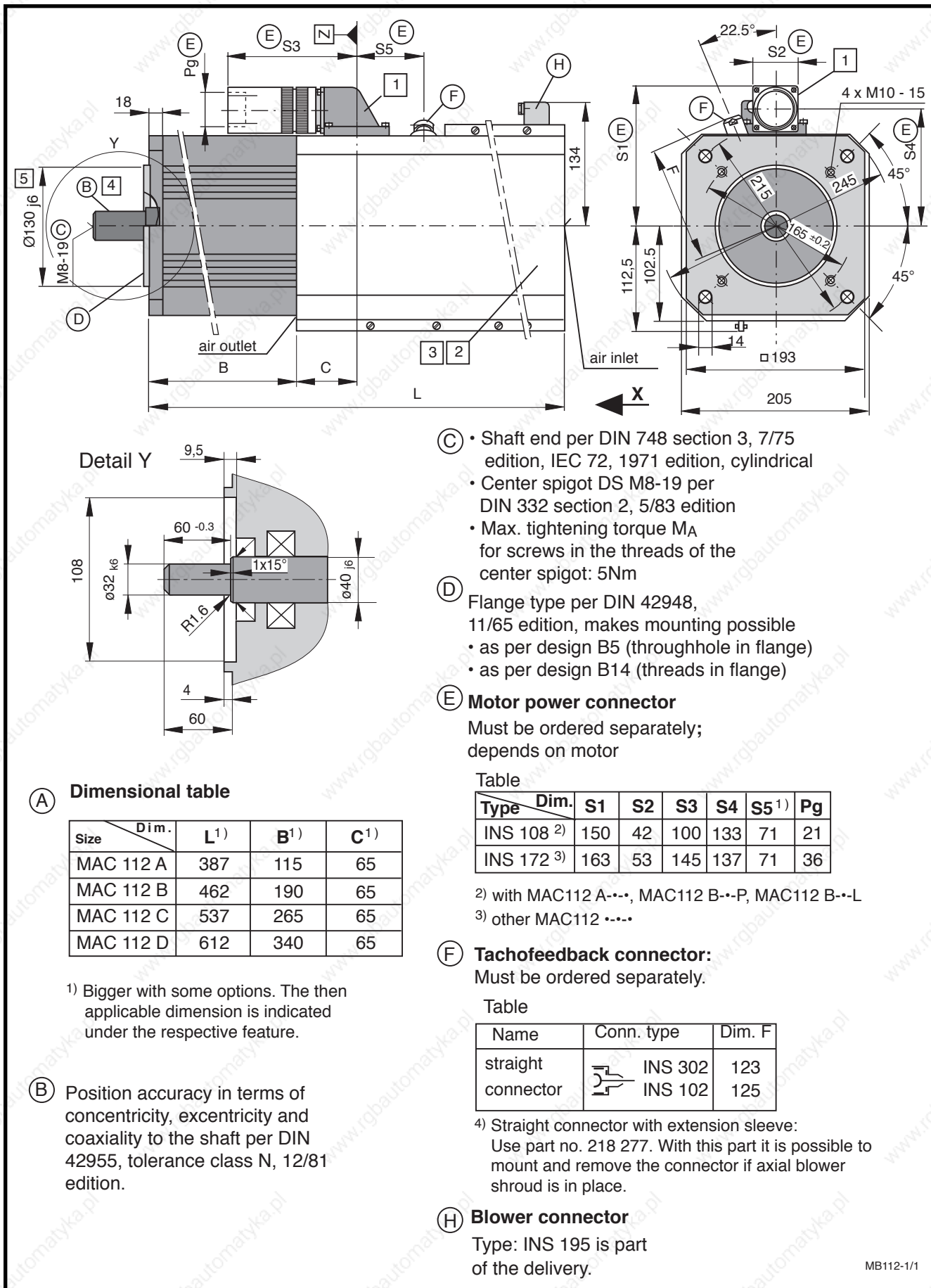

Fig 7.18: Dimensional data - MAC 112 (axial cooling)

Available options

1 Power connection

The output direction of the electrical power connector is selected at the time the order is placed. Possible output directions are:

- to side A
- to side B
- to the right
- to the left

The drawing depicts side A as output direction. The dimensions of any other direction are obtained by a virtual turning of the connector housing around the Z axis.

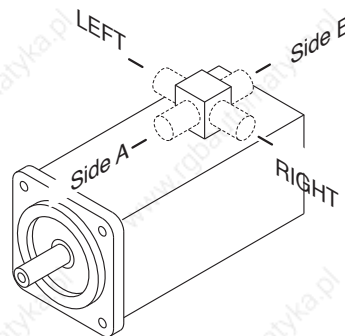

2 Motor version

- Tachofeedback and incremental encoder

Table

Size	Dim.	L	B	C	S5	S6
MAC 112 A		497	115	65	71	154
MAC 112 B		572	190	65	71	154
MAC 112 C		647	265	65	71	154
MAC 112 D		722	340	65	71	154

Table for motors with blocking brakes of 40 Nm and 60 Nm

Size	Dim.	L	B	C	S5	S6
MAC 112 B		622	192	17	119	154
MAC 112 C		697	267	17	119	154
MAC 112 D		772	342	17	119	154

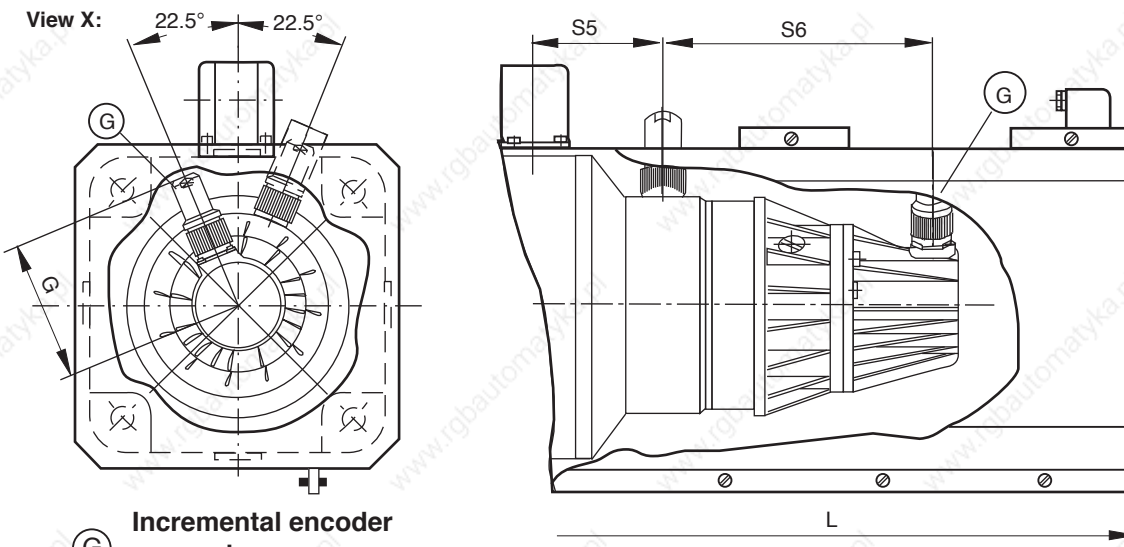

G Incremental encoder connector

Must be ordered separately.

Name	Conn. type	Dim. G
straight		INS 301 123
conn. 1)		INS 101 125

1) Straight connector with extending sleeve:
part no.: 218 277

- Tachofeedback and mounted absolute encoder (see following page)

MB112-1/2

Fig 7.19: Dimensional data - MAC 112 - available options - (axial cooling)

Available options

- Tachofeedback and mounted absolute encoder

Table

Size	Dim.	L	B	C	S5	S6
MAC 112 A		497	115	65	71	84
MAC 112 B		572	190	65	71	84
MAC 112 C		647	265	65	71	84
MAC 112 D		722	340	65	71	84

Table with blocking brake with 40 and 60 Nm holding torque

Size	Dim.	L	B	C	S5	S6
MAC 112 B		622	192	65	119	84
MAC 112 C		697	267	65	119	84
MAC 112 D		772	342	65	119	84

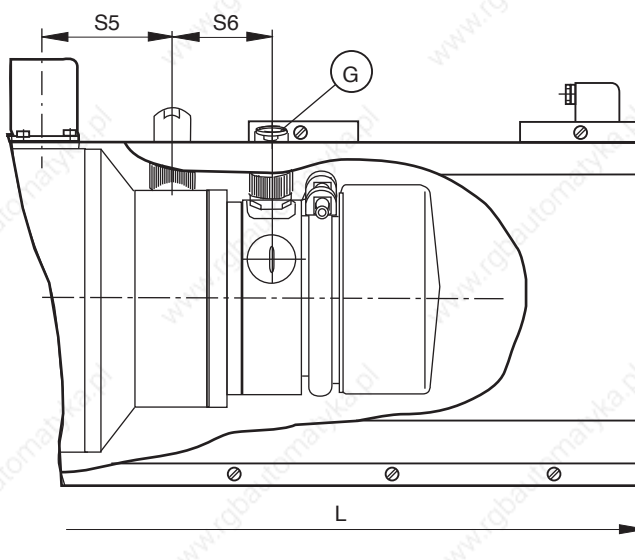
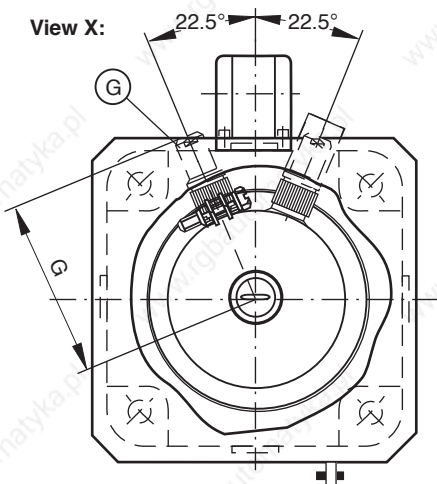

- G Absolute encoder conn.**
Must be ordered separately.

Name	Conn. type	Dim. G
straight conn.	INS 326	104
	INS 92	106

3 Blocking brake

- without blocking brake
Dim. L and B retained
- Standard blocking brake: 14 Nm
Dim. L and B retained
- heavy-duty blocking brake: 40 Nm
(not available with MAC 112A ...)
- extra heavy-duty blocking brake: 60 Nm
(not available with MAC 112A ...)

Table for blocking brake with 40 and 60 Nm

Size	Dim.	Vers. 2		Vers. 4	
		L	B	L	B
MAC 112 B		512	240	622	240
MAC 112 C		587	315	697	315
MAC 112 D		662	390	772	390

Vers. 2 = Motor with tachofeedback
Vers. 4 = Motor with tachofeedback and mounted encoder

4 Output shaft

- plain shaft (recommended type)
- with keyway per DIN 6885 sh. 1, 8/68 edition
(Note! balanced with entire key.)

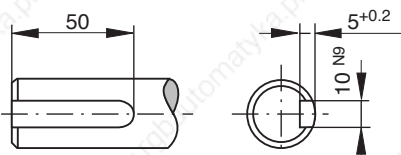

Matching key: DIN 6885-A 10 x 8 x 50
Must be ordered separately.

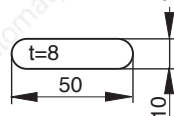

5 Special centering diameter

- $\varnothing 180 j6$

MB112-1/3

Fig 7.20: Dimensional data - MAC 112 - available options - (axial cooling)

7.7. Available Options

Type code fields		Example:	MAC 112 A-0-LD-4 - C/130-A-0/WI 520LV/S000							
1. Motor for analogue drives		MAC								
2. Motor size		112								
3. Motor length		A, B, C, D								
4. Type of cooling:										
natural convection			surface cooling							
			axial				radial			
					blower right		blower below		blower left	
			AC 230 V	AC 115 V	AC 230 V	AC 115 V	AC 230 V	AC 115 V	AC 230 V	AC 115 V
0			1 ¹⁾	2 ¹⁾	6	A	7	B	8	C
5. Type of windings										
Nominal rpm	Standard applications				with increased smooth run quality					
	motor length				motor length					
	A	B	C	D	A	B	C	D		
1500 min ⁻¹	ZD	PD	KD	HD	ZG	PG	KG	HG		
2000 min ⁻¹	VD	LD	HD	FD	VG	LG	HG	FG		
3000 min ⁻¹	LD	GD	ED	ED	LG	GG	EG	EG		
5000 min ⁻¹	--	--	CD ⁶⁾	--	--	--	CG ⁶⁾	--		
6. Motor feedback										
Motor type										
with tachofeedback		2								
with tachofeedback and second shaft end		3								
with tachofeedback and mounted incremental or absolute encoder		4								
Tacho voltage										
set to nominal motor speed		-								
(nominal rpm > 3000 min ⁻¹ : 1,5 V/1000 min ⁻¹)										
(Nennzahl ≤ 3000 min ⁻¹ : 3 V/1000 min ⁻¹)										
1,5 V/1000 min ⁻¹		H								
6 V/1000 min ⁻¹ 3)		L								
Tacho type										
Standard		C								
increased smooth run quality		F								
7. Centering diameter										
for design B05 and B14		130								
for design B05 and B14		180 ²⁾								
8. Power connection										
connector to side A		A								
connector to side B		B								
connector to right (looking onto output shaft)		R								
connector to lefth (looking towards output shaft)		L								
9. Blocking brake										
without blocking brake		0								
with standard blocking brake (45 Nm)		1								
with heavy-duty blocking brake (60 Nm)		2 2) 5)								
extra heavy-duty blocking brake (60 Nm)		3 2) 5)								
Mounted encoder	10. Type ⁴⁾									
	Incremental encoder with standard mounting		WI							
	Incremental encoder with shock-damped mounting		DI							
Absolute encoder		AM								
11. Encoder code ⁴⁾										
For available types, see section 2.4 "Motor feedback"										
12. Special types										
Fixed and documented by INDRAMAT with special number (see Drawing no.: 106-0105-4301-XX)										
Does not apply to standard motors.										

1) For type 3 motors (with 2nd shaft end and tachofeedback). Not available with axial surface cooling.
 2) Type code fields 10 and 11 do not apply to motor types 2 and 3.
 3) only with tacho type "F"
 4) type code fields 10 and 11 do not apply to motor types 2 and 3
 5) not available with motor length A
 6) not available with surface cooling

TLMAC112

Fig 7.21: Type codes - MAC 112

7.8. Special Options

Specification of Option	S003	S005	S011	S013	S018	S019	S029
Special centering diameter 180	X		X			X	X
heavy-duty blocking brake				X	X	X	X
with keyway per DIN 6885, sheet 1	X	X			X		X

Fig 7.22: Special options with a MAC 112

8. MAC 115

8.1. Technical Data

Designation	Symbol	Unit	Motor type MAC ...			
						115 D - - - ES
Nominal motor speed ¹⁾	n	min ⁻¹				1500
Continuous torque at standstill ²⁾	M _{dN}	Nm				57 (88) ⁵⁾
Continuous current at standstill	I _{dN}	A				54 (84) ⁵⁾
Rotor moment of inertia ³⁾	J _M	kgm ²				271 x 10 ⁻⁴
Torque constant at 20 °C	K _m	Nm/A				1.08
Windings resistance at 20 °C	R _A	Ohm				0.084
Windings inductance	L _A	mH				2.4
Maximum peak of pulse current	I _{peak}	A				270
Thermal time constant	T _{th}	min				90 (60) ⁵⁾
Mass ⁴⁾	m _M	kg				60
			115 A - - - HS	115 B - - - GS	115 C - - - ES	115 D - - - DS
Nominal motor speed ¹⁾	n	min ⁻¹	2000	2000	2000	2000
Continuous torque at standstill ²⁾	M _{dN}	Nm	28 (42) ⁵⁾	38 (61) ⁵⁾	47 (75) ⁵⁾	57 (88) ⁵⁾
Continuous current at standstill	I _{dN}	A	32.5 (48.8) ⁵⁾	40.9 (66) ⁵⁾	55 (87) ⁵⁾	68 (104) ⁵⁾
Rotor moment of inertia ³⁾	J _M	kgm ²	123 x 10 ⁻⁴	172 x 10 ⁻⁴	222 x 10 ⁻⁴	271 x 10 ⁻⁴
Torque constant at 20 °C	K _m	Nm/A	0.882	0.952	0.880	0.864
Windings resistance at 20 °C	R _A	Ohm	0.170	0.123	0.074	0.054
Windings inductance	L _A	mH	3.6	3.0	2.0	1.6
Maximum peak of pulse current	I _{peak}	A	163	205	274	338
Thermal time constant	T _{th}	min	90 (60) ⁵⁾	90 (60) ⁵⁾	90 (60) ⁵⁾	90 (60) ⁵⁾
Mass ⁴⁾	m _M	kg	33	41	52	60
			115 A - - - FS	115 B - - - DS	115 C - - - CS	115 D - - - CS
Nominal motor speed ¹⁾	n	min ⁻¹	3000	3000	3000	3000
Continuous torque at standstill ²⁾	M _{dN}	Nm	28 (42) ⁵⁾	38 (56) ⁵⁾	47	57
Continuous current at standstill	I _{dN}	A	48.8 (73.2) ⁵⁾	72 (109) ⁵⁾	91	90
Rotor moment of inertia ³⁾	J _M	kgm ²	123 x 10 ⁻⁴	172 x 10 ⁻⁴	222 x 10 ⁻⁴	271 x 10 ⁻⁴
Torque constant at 20 °C	K _m	Nm/A	0.588	0.544	0.528	0.648
Windings resistance at 20 °C	R _A	Ohm	0.076	0.040	0.027	0.030
Windings inductance	L _A	mH	1.6	1.0	0.7	0.9
Maximum peak of pulse current	I _{peak}	A	244	358	456	451
Thermal time constant	T _{th}	min	90 (60) ⁵⁾	90 (60) ⁵⁾	90 (60) ⁵⁾	90 (60) ⁵⁾
Mass ⁴⁾	m _M	kg	33	41	52	60

¹⁾ The usable motor speed is determined by the drive used.
 Only those usable speeds n_{max} found in the selection lists of the motor-drive combinations are binding.
²⁾ With 60K overtemperature at the motor housing.
 Continuous torque can be limited by the drive. See selection data.
³⁾ With tachogenerator, without holding brake
⁴⁾ With tachogenerator, without holding brake, without blower.
⁵⁾ Parenthetical values apply to versions with surface cooling.

Fig 8.1: Type-dependent motor data

Designation	Symbol	Unit	Data	
Permissible ambient temperature	T_{um}	°C	0 ... + 45	
Permissible storage and transport temperature	T_L	°C	-20 ... +80	
Maximum installation elevation		m	1000 m above sea level	
Protection category			IP 65	
Insulation classification			F	
Housing coat			Black prime coat (RAL 9005)	
Voltage constant of the tachogenerator ¹⁾	C_w	Vs/rad V/min ⁻¹	0.0143 1.5/1000	0.0286 3/1000

¹⁾ Tachovoltage can be selected application-related.

Fig 8.2: General data MAC 115

Designation	Symbol	Unit	Data holding brake	
			Standard	heavy-duty
Principle of action				electrically actuated release
Holding torque	M_H	Nm	45	60
Nominal voltage	U_N	V		DC 24 ± 10%
Nominal current	I_N	A	1.0	1.5
Moment of inertia	J_B	kgm ²	9.5×10^{-4}	32×10^{-4}
Release delay	t_L	ms	55	150
Clamping delay	t_K	ms	18	30
Mass	m_B	kg	1.9	3.5

Fig 8.3: Technical data -holding brake

Designation	Symbol	Unit	Axial cooling	Radial cooling
Power consumption	S_N	VA	40/42	40/42
Nominal voltage	U_N	V	AC 230 or 115 ¹⁾	AC 230 or 115 ¹⁾
Frequency	f	Hz	50/60	50/60
Mass	m_L	kg	approx. 3.3 ²⁾	approx. 3.2 ²⁾
Protection category blower unit			IP 24	IP 24
Protection category blower motor			IP 44	IP 44

¹⁾ 115 V special design
²⁾ Blower shroud for motor with tachofeedback.

Fig 8.4: Technical data - surface cooling

8.2. Torque-Speed Characteristics

MAC 115 A - • - HS
2000 min⁻¹

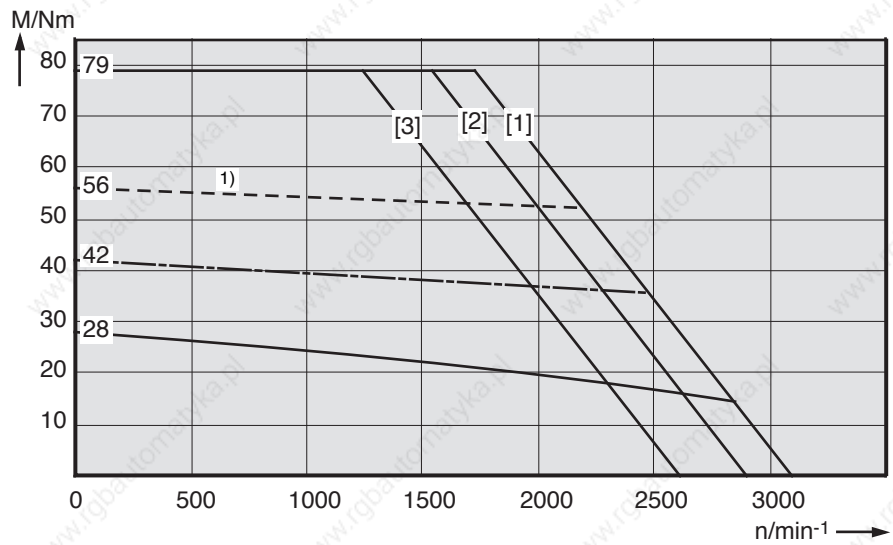

MAC 115 A - • - FS
3000 min⁻¹

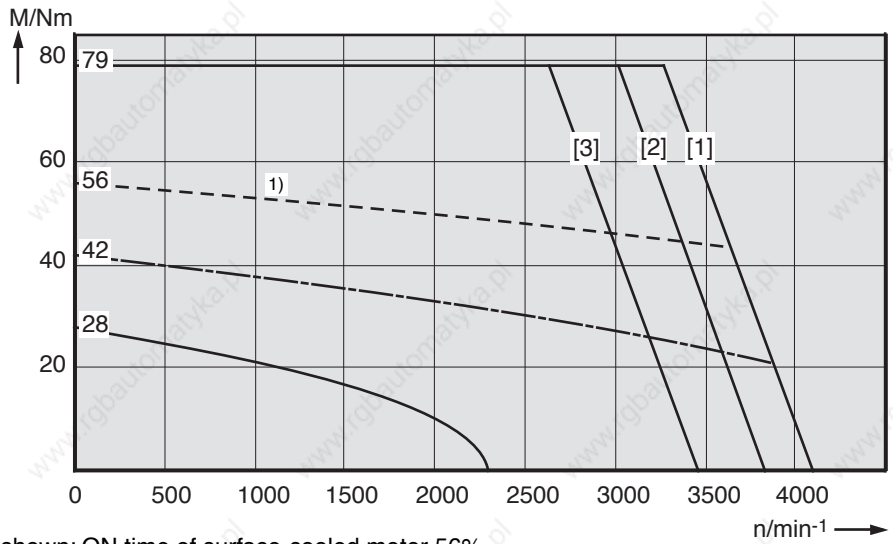

1) shown: ON time of surface-cooled motor 56%

Fig 8.5: Torque-speed characteristics MAC 115

MAC 115 B - - - GS
2000 min⁻¹

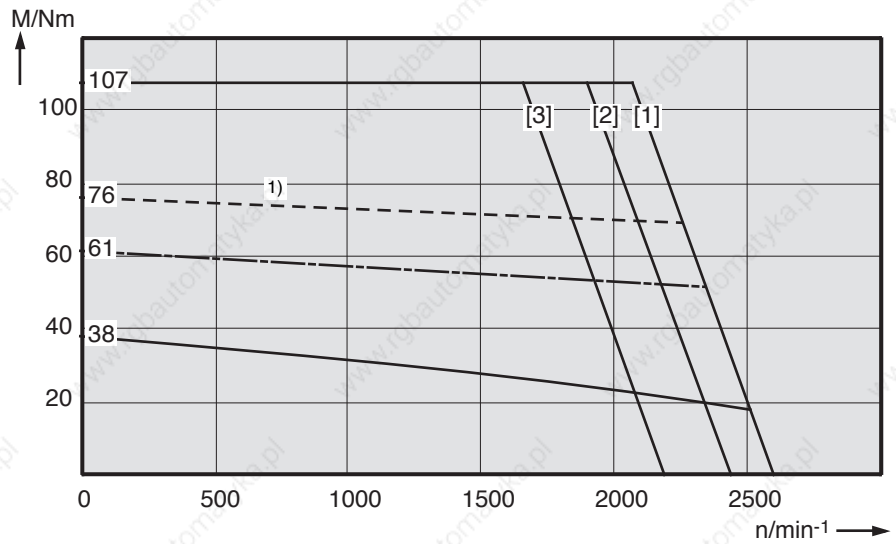

MAC 115 B - - - DS
3000 min⁻¹

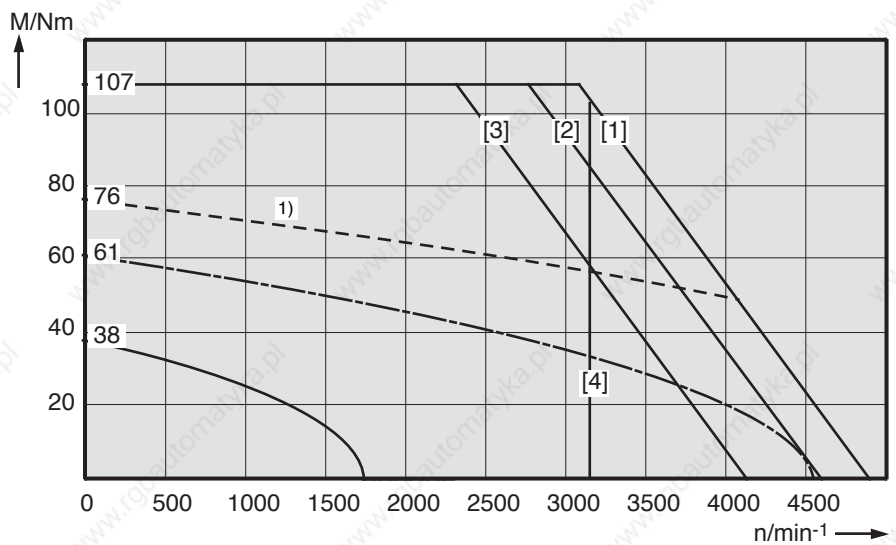

¹⁾ shown: ON time of surface-cooled motor 64%

Fig 8.6: Torque-speed characteristics MAC 115

MAC 115 C - - - ES
2000 min⁻¹

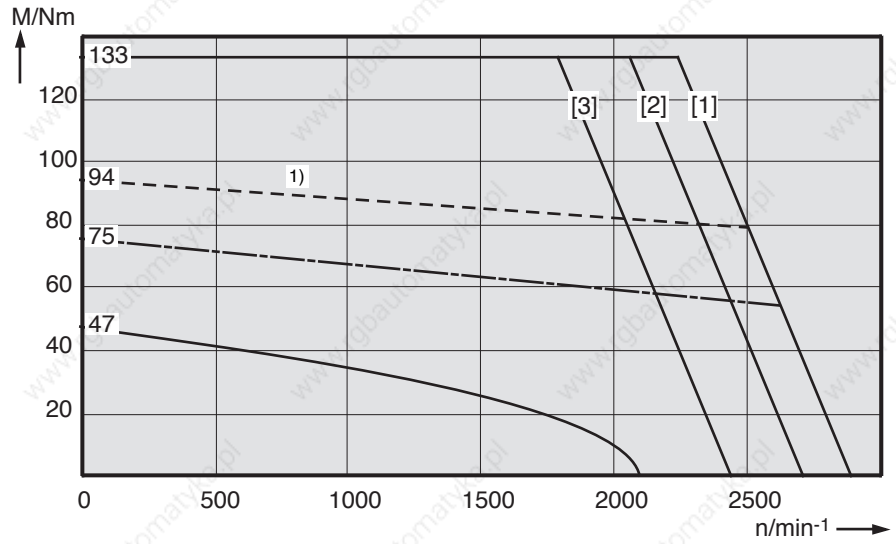

MAC 115 C - - - CS
3000 min⁻¹

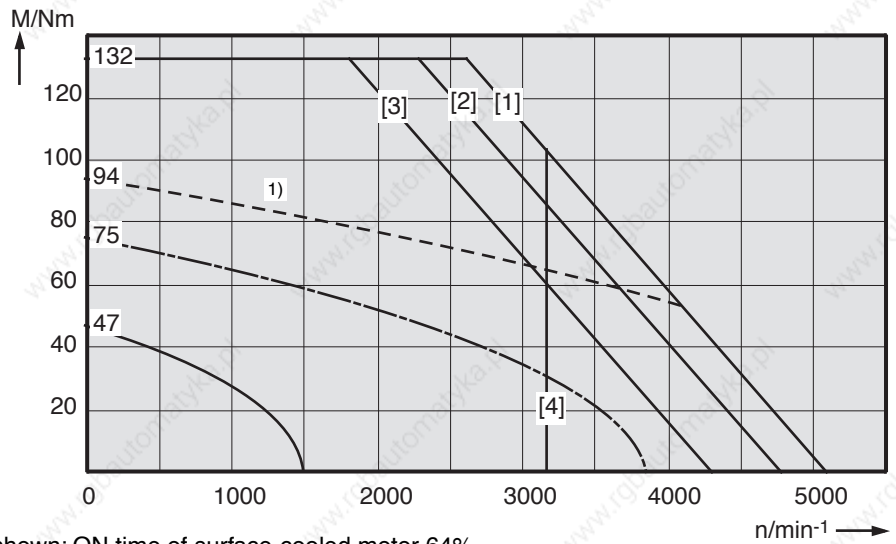

1) shown: ON time of surface-cooled motor 64%

Fig 8.7: Torque-speed characteristics MAC 115

MAC 115 D - - - ES
1500 min⁻¹

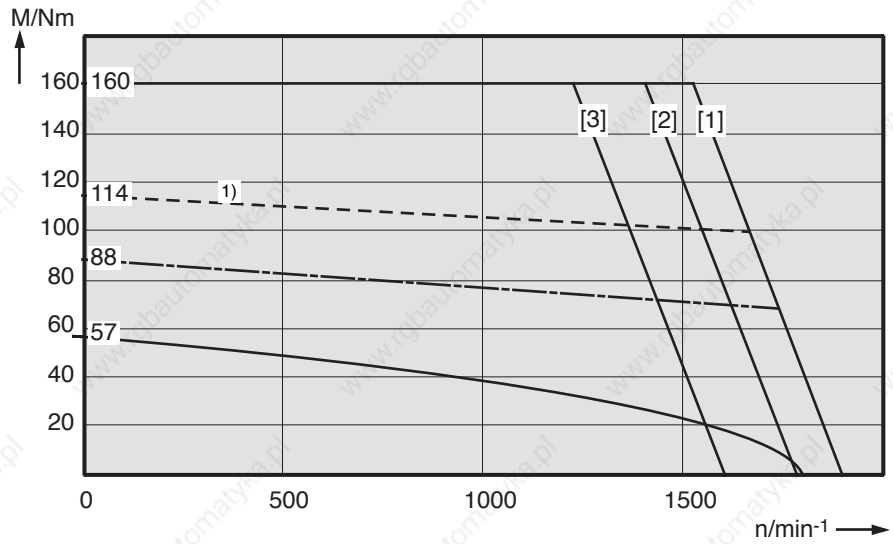

MAC 115 D - - - DS
2000 min⁻¹

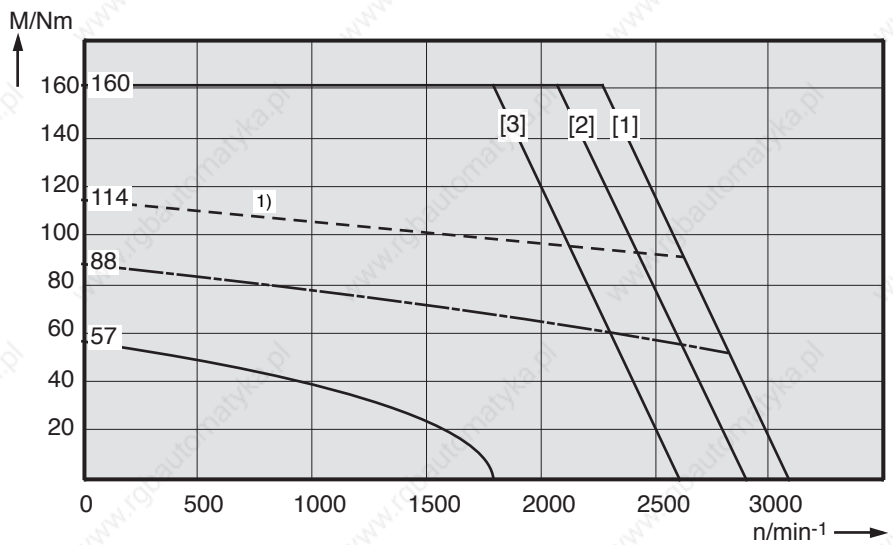

MAC 115 D - - - CS
3000 min⁻¹

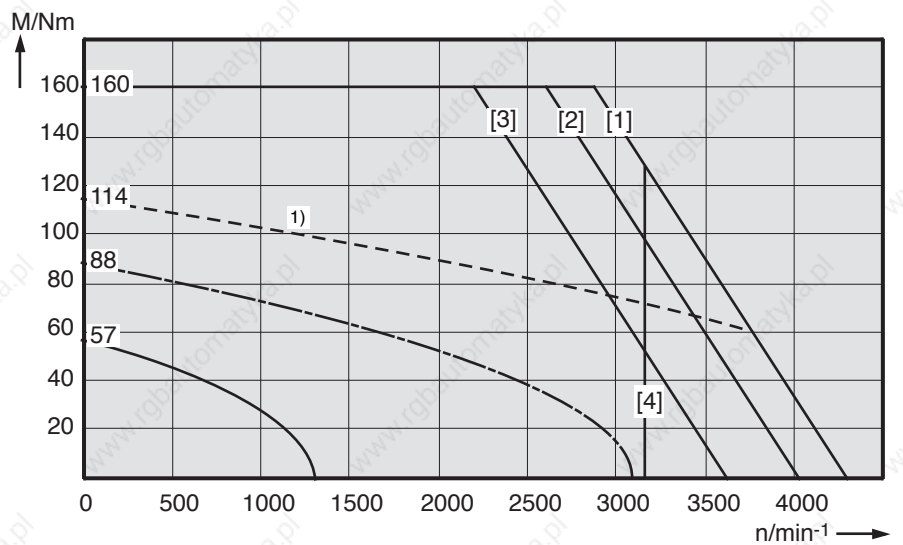

¹⁾ shown: ON time of surface-cooled motor 60%

Fig 8.8: Torque-speed characteristics MAC 115

8.3. Shaft load capacity

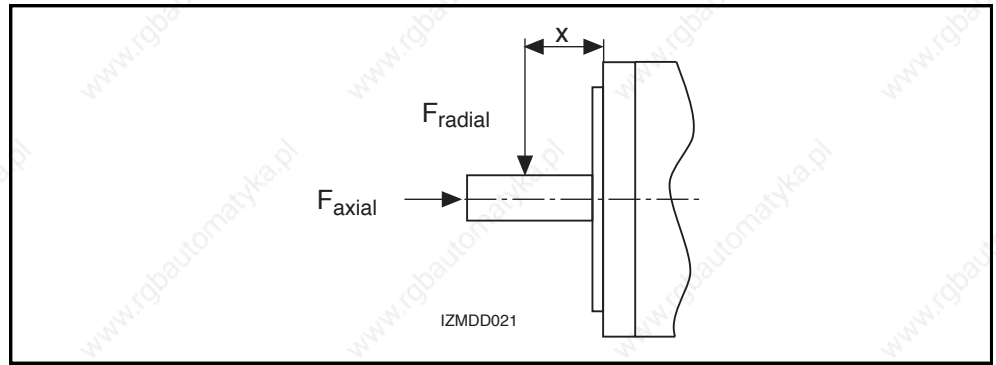

Fig 8.9: Shaft load

Permissible radial force
 F_{radial}

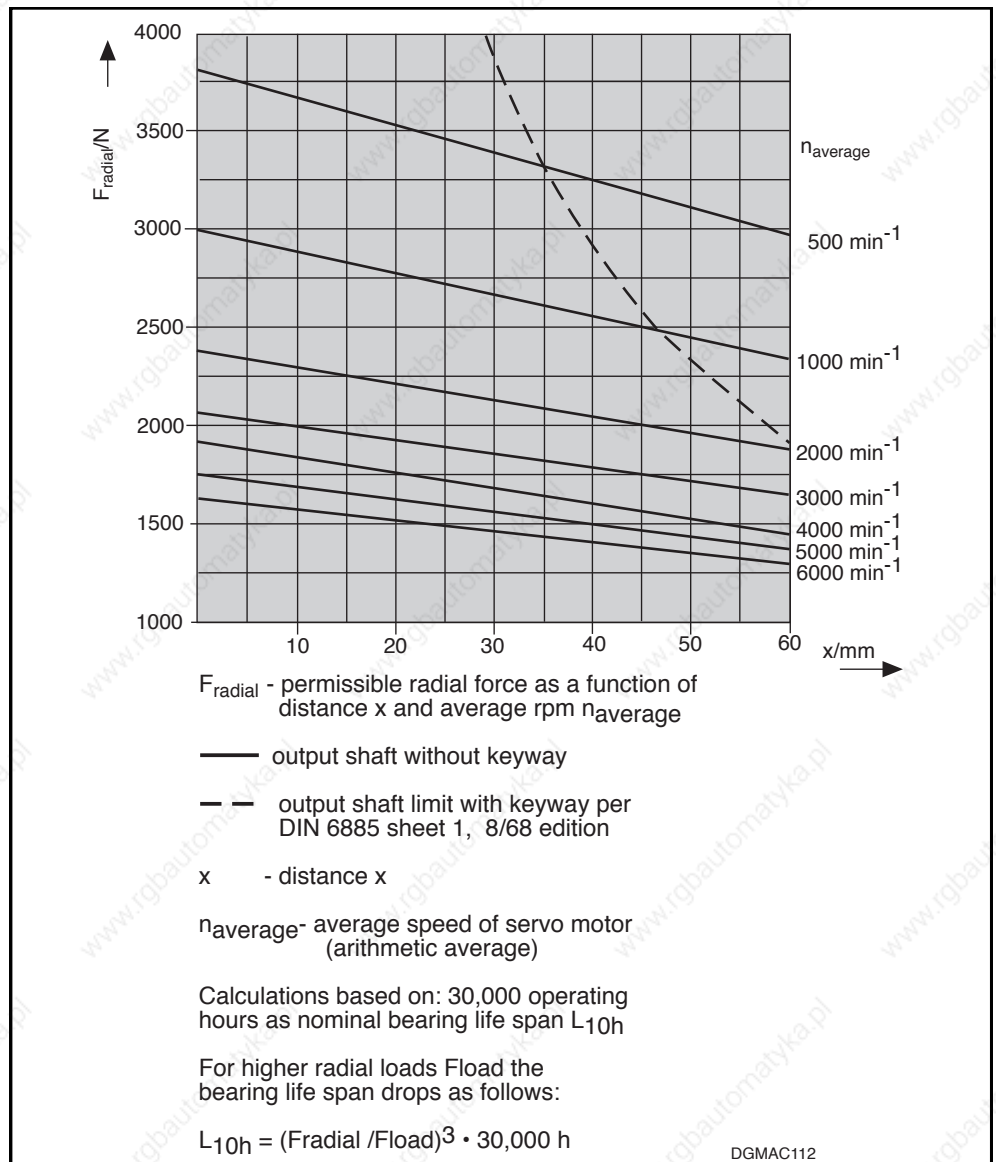

Fig 8.10: Permissible radial force

Permissible axial force
 F_{axial}

$$F_{axial} = 0.35 \cdot F_{radial}$$

F_{axial} - Permissible axial force
 F_{radial} - Permissible radial force

8.4. Dimensional data - natural convection

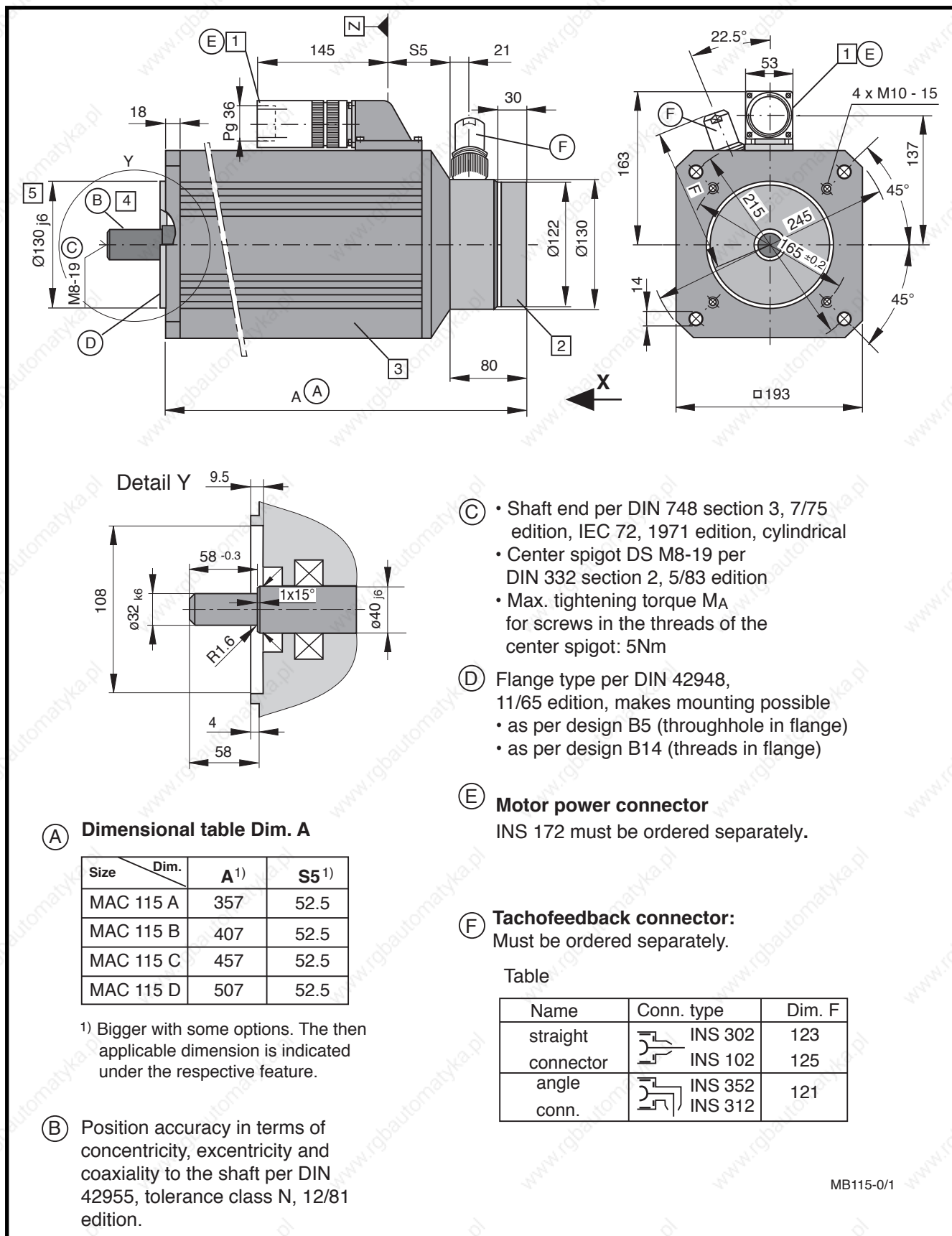

Fig 8.11: Dimensional data - MAC 115 (natural convection)

Available options

1 Power connection

The output direction of the electrical power connector is selected at the time the order is placed. Possible output directions are:

- to side A
- to side B
- to the right
- to the left

The drawing depicts side A as output direction. The dimensions of any other direction are obtained by a virtual turning of the connector housing around the Z axis.

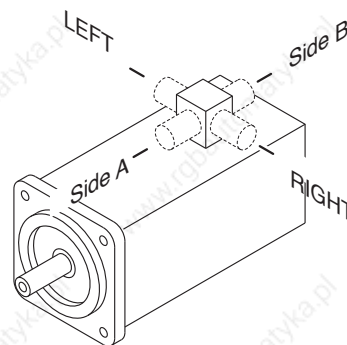

2 Motor version

- Tachofeedback and second shaft end

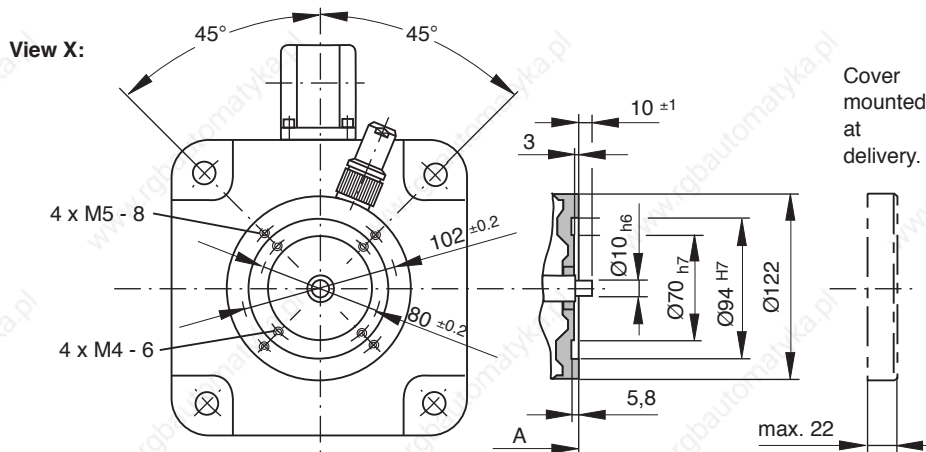

- Tachofeedback and mounted incremental encoder

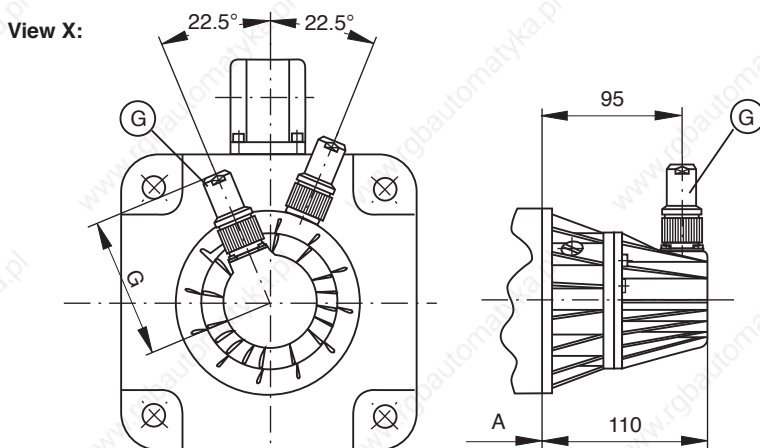

G Incremental encoder connector

Must be ordered separately.

Name	Conn. type	Dim. G
straight conn.	INS 301	88
	INS 101	90
angle conn.	INS 351 INS 311	86

- Tachofeedback and mounted absolute encoder (see following page)

MB115-0/2

Fig 8.12: Dimensional data - MAC 115 - available options - (natural convection)



Available options

- Tachofeedback and mounted absolute encoder

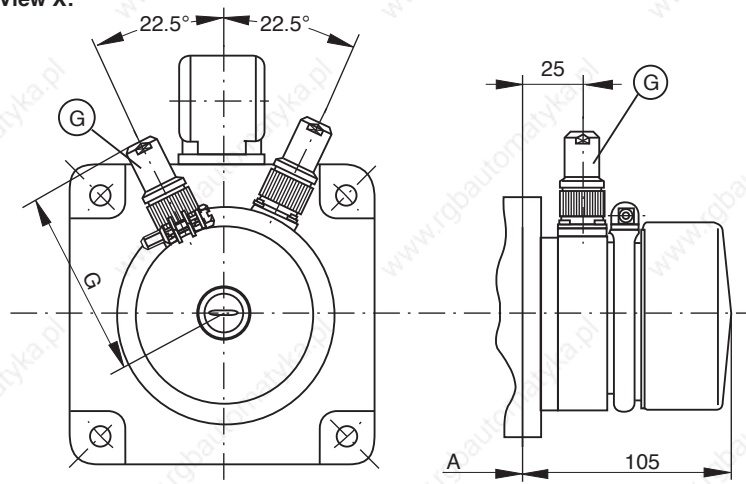
View X:



G Absolute encoder connector
Must be ordered separately.

Name	Connector	Dim. G
straight conn.	 INS 326	104
	 INS 92	106
angle conn.	 INS 322	102

3 Blocking brake

- without blocking brake
Dim. A and S5 are retained.
- Standard blocking brake: 45 Nm
Dim. A and S5 are retained.
- heavy-duty blocking brake: 60 Nm

Table for motors with 60 Nm blocking brakes

Size \ Dim.	A	S5
MAC 115 A	417	95.5
MAC 115 B	467	95.5
MAC 115 C	517	95.5
MAC 115 D	567	95.5

4 Output shaft

- plain shaft (preferred)
- with keyway as per DIN 6885 sheet 1, 8/68 edition
(Note! Balanced with entire key.)

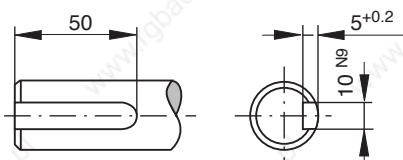

Matching key: DIN 6885-A 10 x 8 x 50
Must be ordered separately.

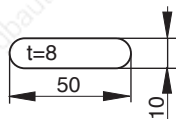

5 Special centering diameter

- $\varnothing 180 j6$

MB115-0/3

Fig 8.13: Dimensional data - MAC 115 -available options - (natural convection)

8.5. Dimensional data - radial cooling

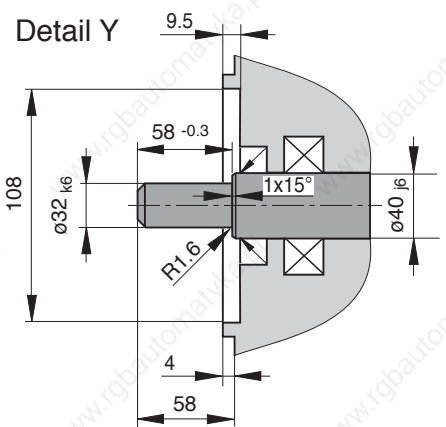
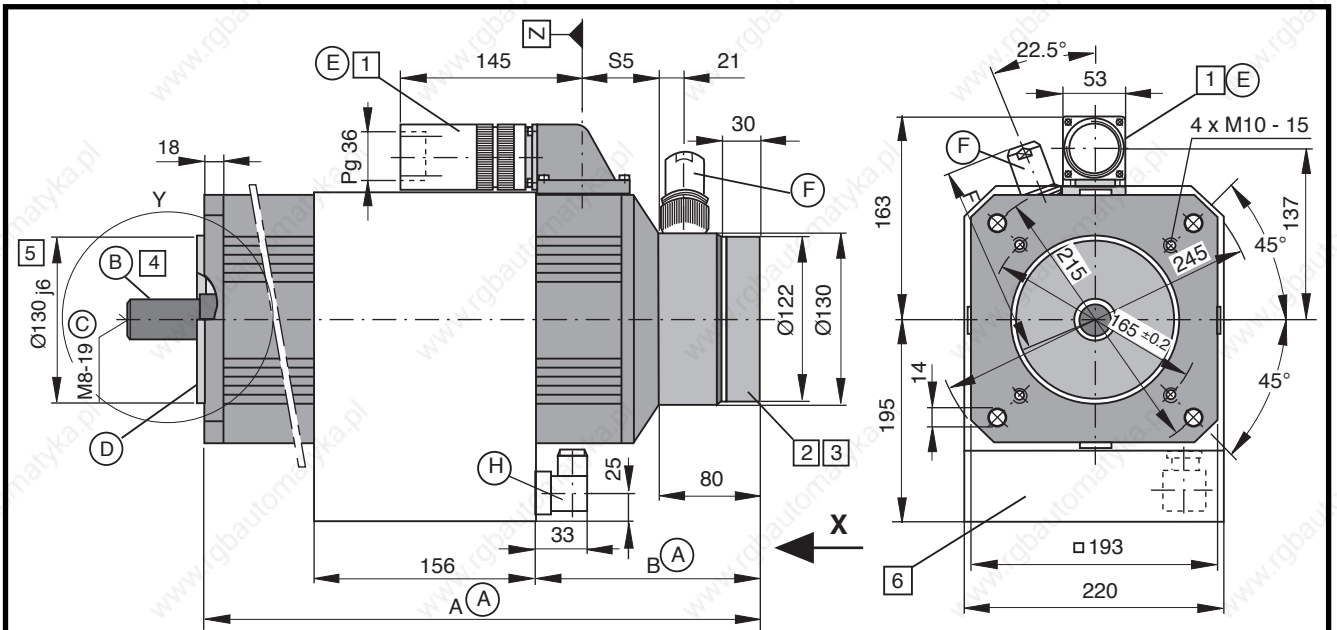

- (C) • Shaft end per DIN 748 section 3, 7/75 edition, IEC 72, 1971 edition, cylindrical
- Center spigot DS M8-19 per DIN 332 section 2, 5/83 edition
- Max. tightening torque M_A for screws in the threads of the center spigot: 5 Nm
- (D) Flange type per DIN 42948, 11/65 edition, makes mounting possible
- as per design B5 (throughhole in flange)
- as per design B14 (threads in flange)
- (E) **Motor power connector**
INS 172 must be ordered separately.

(A) Dimensional table Dim. A and B

Size	Dim.	A ¹⁾	B ¹⁾	S5 ¹⁾
MAC 115 A		357	110	52.5
MAC 115 B		407	170	52.5
MAC 115 C		457	205	52.5
MAC 115 D		507	205	52.5

1) Bigger with some options. The then applicable dimension is indicated under the respective feature.

(B) Position accuracy in terms of concentricity, excentricity and coaxiality to the shaft per DIN 42955, tolerance class N, 12/81 edition.

(F) **Tachofeedback connector:**
Must be ordered separately.

Table

Name	Conn. type	Dim. F
straight connector	INS 302	123
	INS 102	125
angle conn.	INS 352	121
	INS 312	

(H) **Blower connector: INS 195**
Part of general delivery.

MB115-1rad/1

Fig 8.14: Dimensional data - MAC 115 (radial cooling)

Available options

1 Power connection

The output direction of the electrical power connector is selected at the time the order is placed. Possible output directions are:

- to side A
- to side B
- to the right
- to the left

The drawing depicts side A as output direction. The dimensions of any other direction are obtained by a virtual turning of the connector housing around the Z axis.

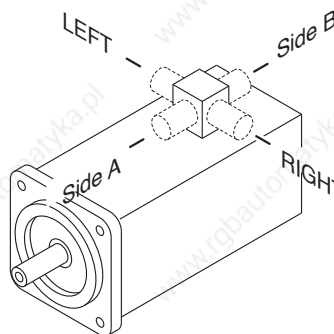

2 Motor version

- Tachofeedback and second shaft end

View X:

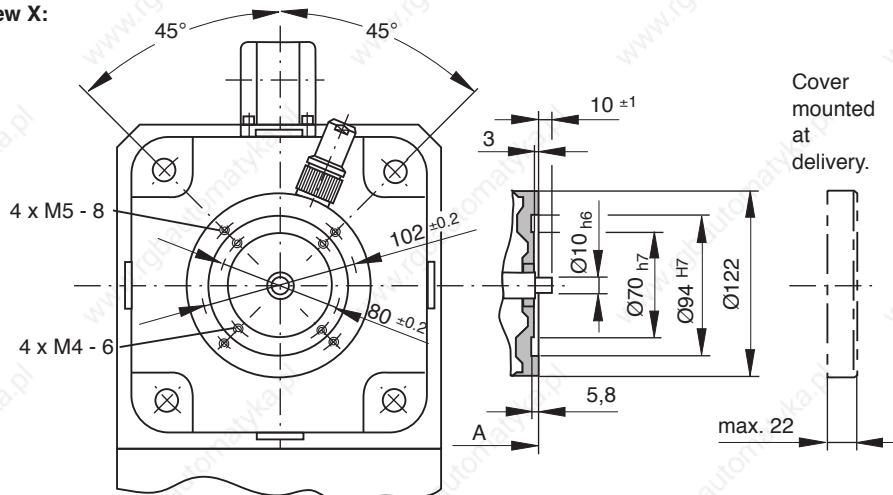

- Tachofeedback and mounted incremental encoder

View X:

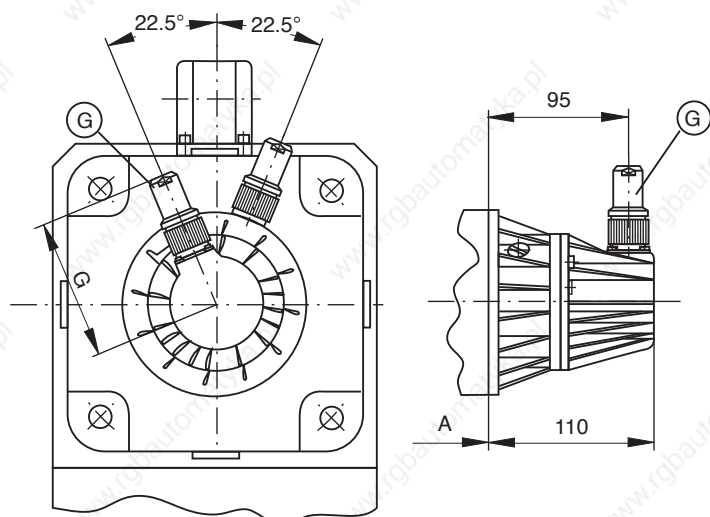

G Incremental encoder connector

Must be ordered separately.

Name	Conn. type	Dim. G
straight conn.	INS 301	88
	INS 101	90
angle conn.	INS 351 INS 311	86

- Tachofeedback and mounted absolute encoder (see following page)

MB115-1rad/2

Fig 8.15: Dimensional data - MAC 115 - available options - (radial cooling)

Available options

- Tachofeedback and mounted absolute encoder

View X:

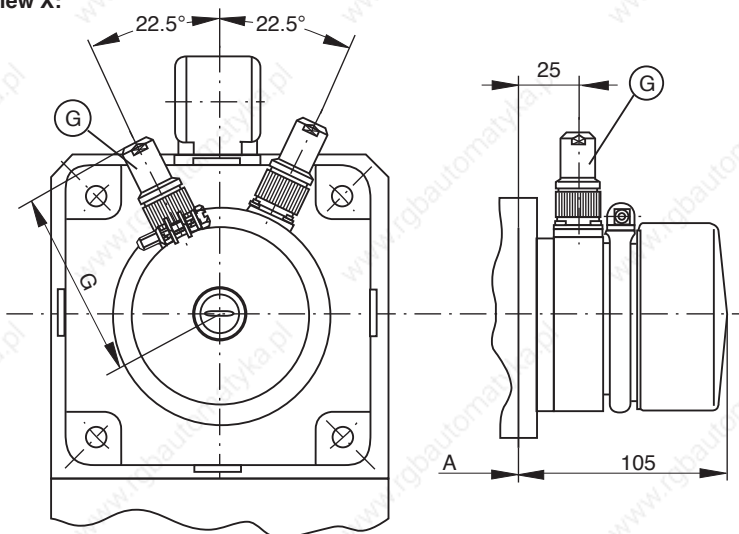

Ⓒ **Absolute encoder conn.**
Must be ordered separately.

Name	Conn. type	Dim. G
straight conn.	INS 326	104
	INS 92	106
angle conn.	INS 322	102

3 Blocking brake

- without blocking brake
Dim. A, B and S5 retained
- Standard blocking brake: 45 Nm
Dim. A, B and S5 retained
- heavy-duty blocking brake: 60 Nm

Table for blocking brake with 60 Nm

Size \ Dim.	A	B	S5
MAC 115 A	417	155	95.5
MAC 115 B	467	225	95.5
MAC 115 C	517	255	95.5
MAC 115 D	567	255	95.5

4 Output shaft

- plain shaft (recommended type)
- with keyway per DIN 6885 sh. 1, 8/68 edition
(Note! balanced with entire key.)

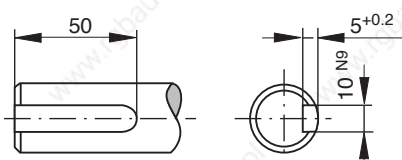

Matching key: DIN 6885-A 10 x 8 x 50
Must be ordered separately.

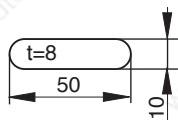

5 Special centering diameter

- $\varnothing 180 j6$

6 Blower arrangement

Looking towards motor shaft.

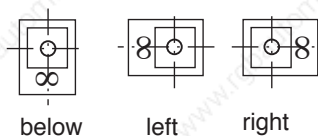

MB115-1rad/3

Fig 8.16: Dimensional data - MAC 115 - available options - (radial cooling)

8.6. Dimensional data - axial cooling

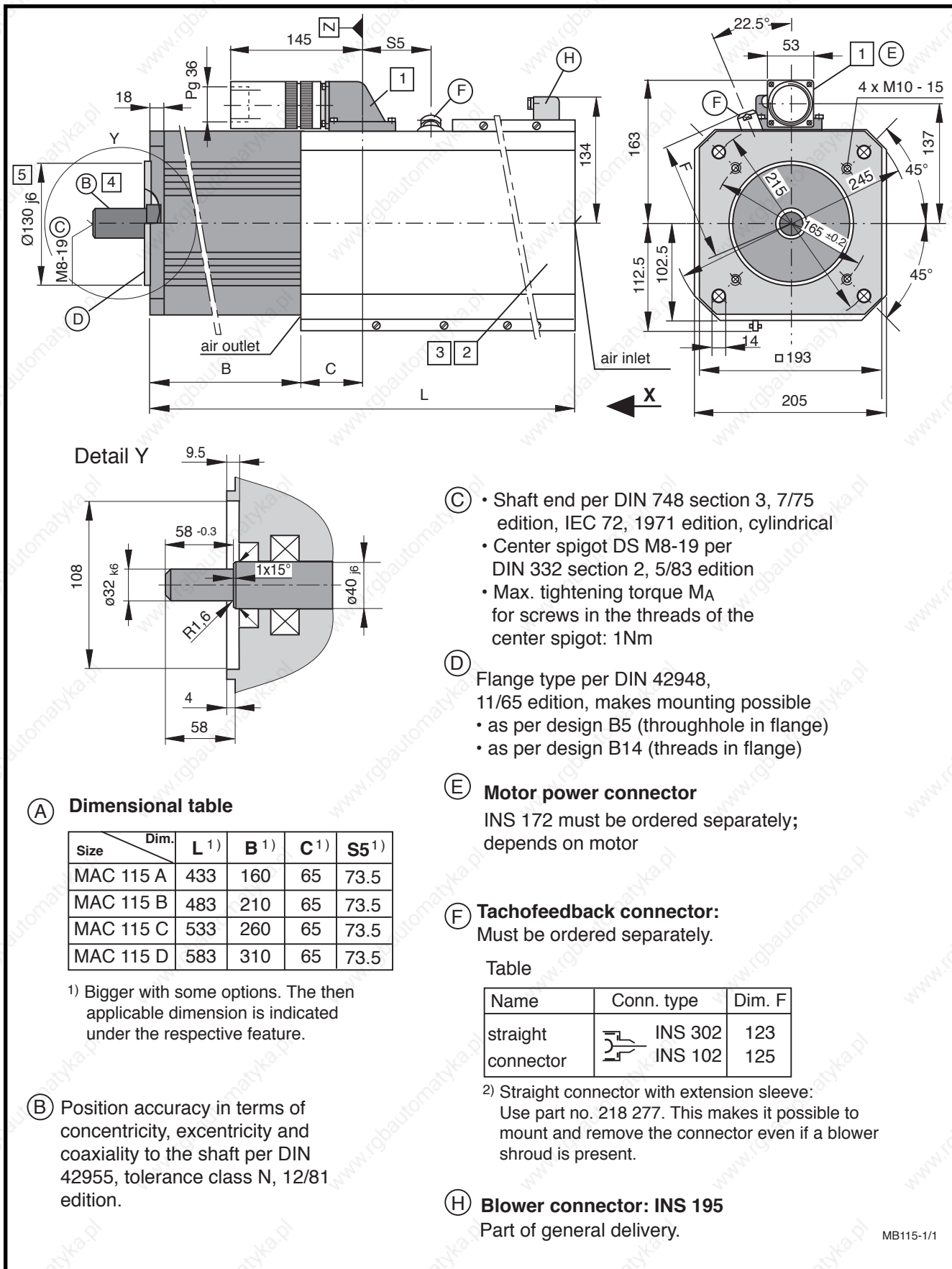

Fig 8.17: Dimensional data - MAC 115 (axial cooling)

Available options

1 Power connection

The output direction of the electrical power connector is selected at the time the order is placed. Possible output directions are:

- to side A
- to side B
- to the right
- to the left

The drawing depicts side A as output direction. The dimensions of any other direction are obtained by a virtual turning of the connector housing around the Z axis.

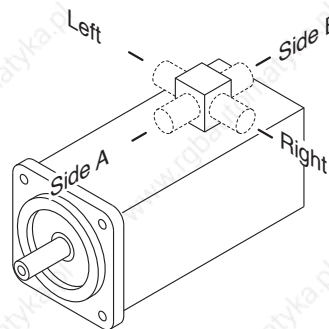

2 Motor type

- Tachofeedback and mounted incremental encoder

Table

Size	Dim.	L	B	C	S5	S6
MAC 115 A		543	160	65	73.5	154
MAC 115 B		593	210	65	73.5	154
MAC 115 C		643	260	65	73.5	154
MAC 115 D		693	310	65	73.5	154



Table for motor with 60 Nm blocking brake

Size	Dim.	L	B	C	S5	S6
MAC 115 A		603	220	22	116.5	154
MAC 115 B		653	270	22	116.5	154
MAC 115 C		703	320	22	116.5	154
MAC 115 D		753	370	22	116.5	154

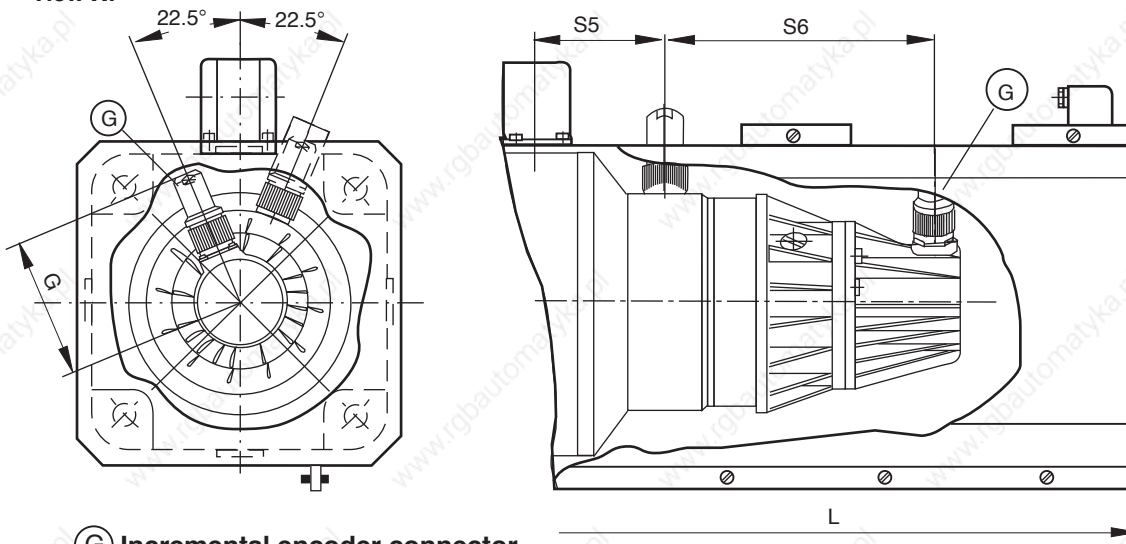
View X:



G Incremental encoder connector
Must be ordered separately.

Name	Connector	Dim. G
gerader Stecker 1)	 INS 302	123
	 INS 102	125

1) Straight connector with extension sleeve:
part no.: 218 277

- Tachofeedback and mounted absolute encoder (see next page)

MB115-1/2

Fig 8.18: Dimensional data - MAC 115 - available options - (axial cooling)

Available options

- Tachofeedback and mounted absolute encoder

Table

Size	Dim.	L	B	C	S5	S6
MAC 115 A		543	160	65	73.5	84
MAC 115 B		593	210	65	73.5	84
MAC 115 C		643	260	65	73.5	84
MAC 115 D		693	310	65	73.5	84

Table of blocking brake with 60 Nm holding torque

Size	Dim.	L	B	C	S5	S6
MAC 115 A		603	220	22	116.5	84
MAC 115 B		653	270	22	116.5	84
MAC 115 C		703	320	22	116.5	84
MAC 115 D		753	370	22	116.5	84

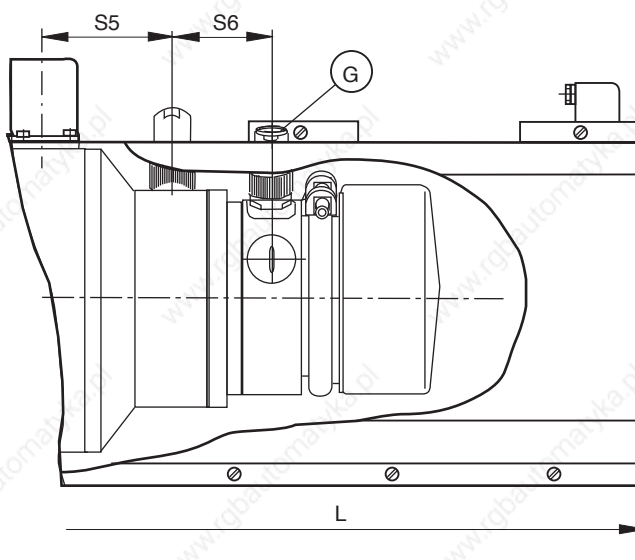
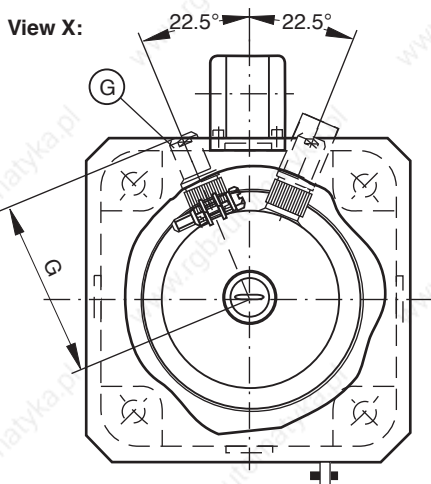

G Absolute encoder conn.
Must be ordered separately.

Name	Conn. type	Dim. G
straight conn.	INS 326	104
	INS 92	106

3 Blocking brake

- without blocking brake
Dim. L and B retained
- Standard blocking brake: 45 Nm
Dim. L and B retained
- heavy-duty blocking brake: 60 Nm

Table for blocking brake with 60 Nm

Size	Dim.	Vers. 2			Vers. 4		
		L	B	S5	L	B	S5
MAC 115 A		543	160	116.5	603	222	116.5
MAC 115 B		593	210	116.5	653	270	116.5
MAC 115 C		643	260	116.5	703	320	116.5
MAC 115 D		693	310	116.5	753	370	116.5

Vers. 2 = Motor with tachofeedback
Vers. 4 = Motor with tachofeedback and mounted encoder

4 Output shaft

- plain shaft (recommended type)
- with keyway per DIN 6885 sh. 1, 8/68 edition
(Note! balanced with entire key.)

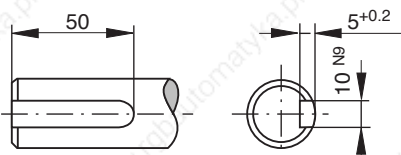

Matching key: DIN 6885-A 10 x 8 x 50
Must be ordered separately.

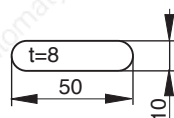

5 Special centering diameter

- $\varnothing 180 j6$

MB115-1/3

Fig 8.19: Dimensional data - MAC 115 - available options - (axial cooling)

8.7. Available Options

Type code fields		Example: MAC 115 A-0-HS-4 - C/130-A-0/WI 520LV/S000	
1. Motor for analogue drives	MAC		
2. Motor size	115		
3. Motor length	A, B, C, D		
4. Type of cooling:			
natural convection		surface cooling	
		axial	
		radial	
		blower right	
		blower below	
		blower left	
		AC 230 V	
		AC 115 V	
		AC 230 V	
		AC 115 V	
		AC 230 V	
		AC 115 V	
0	1 ¹⁾	2 ¹⁾	6 A 7 B 8 C
5. Type of windings			
Nominal rpm		Motor length	
		A B C D	
1500 min ⁻¹	--	--	ES
2000 min ⁻¹	HS	GS	DS
3000 min ⁻¹	FS	DS	CS
6. Motor feedback			
Motor type			
with tachofeedback		2	
with tachofeedback and second shaft end		3	
with tachofeedback and mounted incremental or absolute encoder		4	
Tacho voltage			
set to nominal motor speed		-	
(nominal rpm > 3000 min ⁻¹)		- ¹ : 1.5 V/1000 min ⁻¹)	
(nominal rpm ≤ 3000 min ⁻¹)		- ¹ : 3 V/1000 min ⁻¹)	
1.5 V/1000 min ⁻¹		H	
Tacho type			
Standard		C	
increased smooth run quality		F	
7. Centering diameter			
for design B05 and B14		130	
for design B05 and B14		180	
8. Power connection			
connector to side A		A	
connector to side B		B	
connector to right (looking onto output shaft)		R	
connector to left (looking onto output shaft)		L	
9. Blocking brake			
without blocking brake		0	
with standard blocking brake (45 Nm)		1	
with heavy-duty blocking brake (60 Nm)		2	
Mounted encoder	10. Type ²⁾		
	Incremental encoder with standard mounting		WI
Incremental encoder with shock-damped mounting		DI	
Absolute encoder		AM	
11. Encoder code ²⁾			
For available types, see section 2.4 "Motor feedback"			
12. Special types			
Fixed and documented by INDRAMAT with special number (see Drawing no.: 106-0105-4301-XX)			
Does not apply to standard motors.			

TLMAC115

Fig 8.20: Type codes MAC 115

8.8. Special Options

Specification of Option	S001
with keyway per DIN 6885, sheet 1	X

Fig 8.21: Special options with a MAC 115

9. Electrical Power Connection

9.1. Terminal Diagram

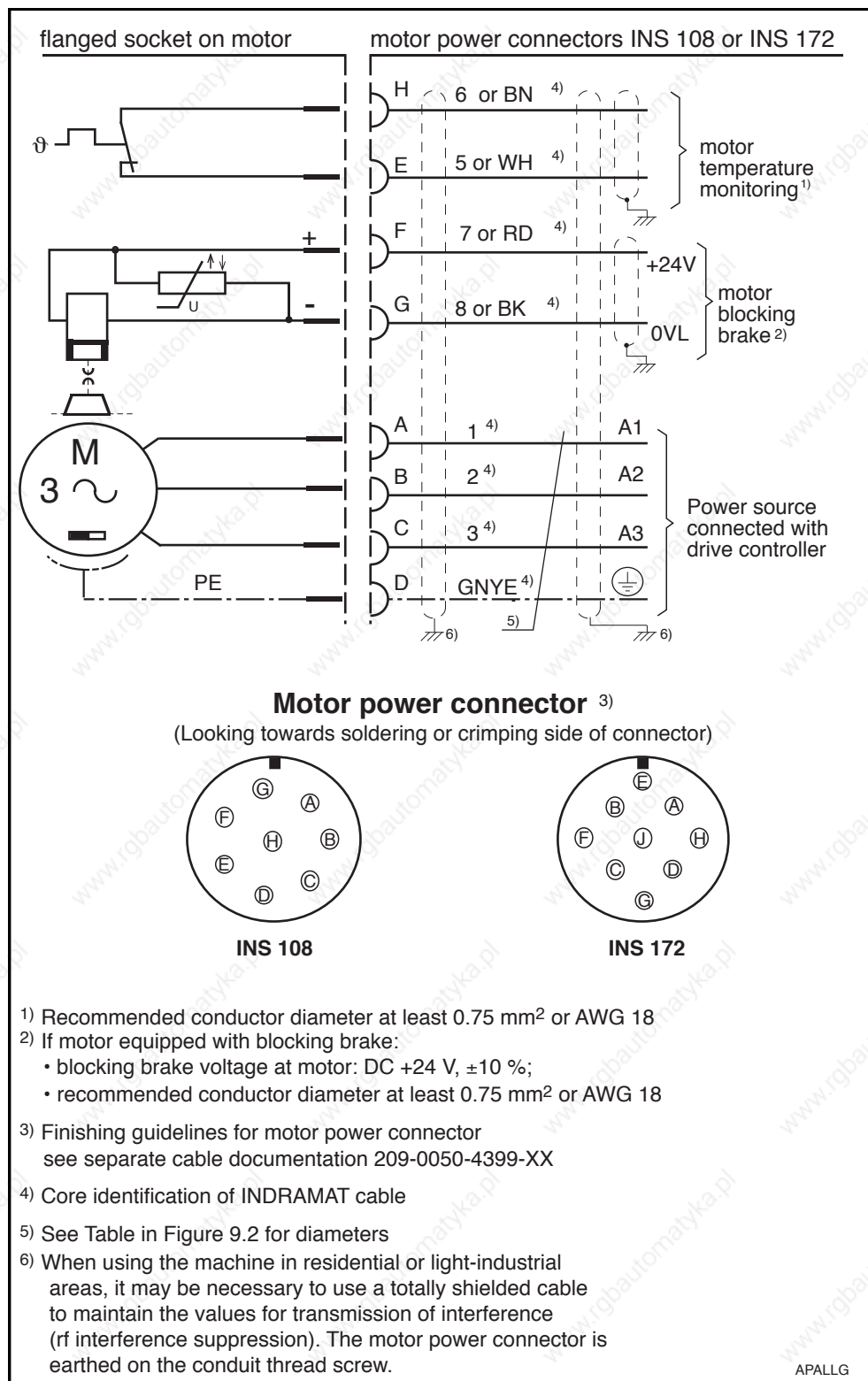

Fig 9.1: Power connection

9.2. Connector-Cable Allocations

Servo motor MAC ...	Cooling	Motor phase current ¹⁾	Power conn. Min. cross section ¹⁾		Motor power connector		INDRAMAT Motor power cable			
			mm ²	AWG ²⁾	Crimping Type ³⁾	Soldering type ³⁾	w/o total shield	with total shield	cross section mm ²	
		A								
063 A-0-ES	natural convection	1.8	0.75	18	---	INS 108/06	INK 253	INK 653	0.75	
063 A-0-RS		2.9	0.75	18	---	INS 108/06	INK 253	INK 653	0.75	
063 B-0-GS		3.0	0.75	18	---	INS 108/06	INK 253	INK 653	0.75	
063 B-0-JS		4.7	0.75	18	---	INS 108/06	INK 253	INK 653	0.75	
063 C-0-MS		3.3	0.75	18	---	INS 108/06	INK 253	INK 653	0.75	
063 C-0-HS		5.6	0.75	18	---	INS 108/06	INK 253	INK 653	0.75	
063 D-0-JS		4.2	0.75	18	---	INS 108/06	INK 253	INK 653	0.75	
063 D-0-FS		6.9	0.75	18	---	INS 108/06	INK 253	INK 653	0.75	
063 A--ES		surface cooling	2.2	0.75	18	---	INS 108/06	INK 253	INK 653	0.75
063 A--RS			3.6	0.75	18	---	INS 108/06	INK 253	INK 653	0.75
063 B--GS	3.3		0.75	18	---	INS 108/06	INK 253	INK 653	0.75	
063 B--JS	5.4		0.75	18	---	INS 108/06	INK 253	INK 653	0.75	
063 C--MS	4.3		0.75	18	---	INS 108/06	INK 253	INK 653	0.75	
063 C--HS	7.1		0.75	16	---	INS 108/06	INK 253	INK 653	0.75	
063 D--JS	5.4		0.75	18	---	INS 108/06	INK 253	INK 653	0.75	
063 D--FS	9.0		0.75	16	---	INS 108/06	INK 253	INK 653	0.75	
Continued on next page										
<p>¹⁾ Motor phase currents and connection cross sections apply to S1 continuous operation or S6 intermittent operation with those limit values (respective ON time and duty cycle time) given in the torque-speed operating curves.</p> <p>²⁾ Minimum cross section of power connection per EN 60 204, sec. 1, table 5, cols. C or E or UL 508 table 50.2, but at least 0.75 mm² or AWG 18. Cables per UL 508 may only be soldered not crimped to the motor power connector.</p> <p>³⁾ Data following the slash identify the type of bushing contact as either for crimping or soldering.</p>										

Servo motor MAC ...	Cooling	Motor phase current ¹⁾	Power conn. Min. cross section ¹⁾		Motor power connector		INDRAMAT Motor power cable			
			mm ²	AWG ²⁾	Crimping Type ³⁾	Soldering type ³⁾	w/o total shield	with total shield	cross section mm ²	
										A
071 A-0-HS	natural convection	2.1	0.75	18	---	INS 108/06	INK 253	INK 653	0.75	
071 A-0-OS		3.1	0.75	18	---	INS 108/06	INK 253	INK 653	0.75	
071 A-0-ES		4.1	0.75	18	---	INS 108/06	INK 253	INK 653	0.75	
071 A-0-VS		6.0	0.75	18	---	INS 108/06	INK 253	INK 653	0.75	
071 B-0-FS		4.2	0.75	18	---	INS 108/06	INK 253	INK 653	0.75	
071 B-0-TS		6.0	0.75	18	---	INS 108/06	INK 253	INK 653	0.75	
071 B-0-PS		7.8	0.75	16	---	INS 108/06	INK 253	INK 653	0.75	
071 B-0-KS		11.6	1.0	14	---	INS 108/06	INK 250	INK 650	1.5	
071 C-0-US		6.0	0.75	18	---	INS 108/06	INK 253	INK 653	0.75	
071 C-0-NS		9.0	0.75	16	---	INS 108/06	INK 253	INK 653	0.75	
071 C-0-JS		12.5	1.5	14	INS 108/02	INS 108/06	INK 250	INK 650	1.5	
071 C-0-GS		18.0	2.5	12	INS 108/03	INS 108/06	INK 202	INK 602	2.5	
071 A--HS		surface cooling	3.3	0.75	18	---	INS 108/06	INK 253	INK 653	0.75
071 A--OS			4.9	0.75	18	---	INS 108/06	INK 253	INK 653	0.75
071 A--ES			6.4	0.75	18	---	INS 108/06	INK 253	INK 653	0.75
071 A--VS			9.5	1.0	16	---	INS 108/06	INK 250	INK 650	1.5
071 B--FS	6.4		0.75	18	---	INS 108/06	INK 253	INK 653	0.75	
071 B--TS	9.5		1.0	16	---	INS 108/06	INK 250	INK 650	1.5	
071 B--PS	12.4		1.5	14	INS 108/02	INS 108/06	INK 250	INK 650	1.5	
071 B--KS	18.2		2.5	12	INS 108/03	INS 108/06	INK 202	INK 602	2.5	
071 C--US	9.6		1.0	16	---	INS 108/06	INK 253	INK 653	1.5	
071 C--NS	14.4		2.5	14	INS 108/03	INS 108/06	INK 202	INK 602	2.5	
071 C--JS	20.2		4.0	10	INS 108/04	INS 108/06	INK 203	INK 603	4.0	
071 C--GS	28.9		6.0	10	INS 108/06	INS 108/06	INK 204	INK 604	6.0	

Continued on next page

1) Motor phase currents and connection cross sections apply to S1 continuous operation or S6 intermittent operation with those limit values (respective ON time and duty cycle time) given in the torque-speed operating curves.

2) Minimum cross section of power connection per EN 60 204, sec. 1, table 5, cols. C or E or UL 508 table 50.2, but at least 0.75 mm² or AWG 18. Cables per UL 508 may only be soldered not crimped to the motor power connector.

3) Data following the slash identify the type of bushing contact as either for crimping or soldering.

Servo motor MAC ...	Cooling	Motor phase current ¹⁾ A	Power conn. Min. cross section ¹⁾		Motor power connector		INDRAMAT Motor power cable		
			mm ²	AWG ²⁾	Crimping Type ³⁾	Soldering type ³⁾	w/o total shield	with total shield	cross section mm ²
090 A-0-Z•	natural convection	6.6	0.75	18	---	INS 108/06	INK 253	INK 653	0.75
090 A-0-R•		9.3	1.0	16	INS 108/02	INS 108/06	INK 250	INK 650	1.5
090 B-0-P•		9.7	1.0	16	INS 108/02	INS 108/06	INK 250	INK 650	1.5
090 B-0-N•		10.6	1.0	14	INS 108/02	INS 108/06	INK 250	INK 650	1.5
090 B-0-J•		14.8	1.5	14	INS 108/02	INS 108/06	INK 250	INK 650	1.5
090 C-0-K•		13.9	1.5	14	INS 108/02	INS 108/06	INK 250	INK 650	1.5
090 C-0-G•		20.2	2.5	10	INS 108/03	INS 108/06	INK 202	INK 602	2.5
090 C-0-E•		28.6	6.0	10	---	INS 108/06	INK 204	INK 604	6.0
090 A--Z•		surface cooling	8.9	0.75	16	---	INS 108/06	INK 253	INK 653
090 A--R•	13.3		1.5	14	INS 108/02	INS 108/06	INK 250	INK 650	1.5
090 B--P•	14.2		1.5	14	INS 108/02	INS 108/06	INK 250	INK 650	1.5
090 B--N•	16.3		2.5	12	INS 108/03	INS 108/06	INK 202	INK 602	2.5
090 B--J•	23.2		4.0	10	INS 108/04	INS 108/06	INK 203	INK 603	4.0
090 C--K•	21.3		4.0	10	INS 108/04	INS 108/06	INK 203	INK 603	4.0
090 C--G•	33.7		6.0	8	---	INS 108/06	INK 204	INK 604	6.0
090 C--E•	42.5		10.0	6	INS 172/10	INS 172/25	INK 205	INK 605	10.0
Continued on next page									
¹⁾ Motor phase currents and connection cross sections apply to S1 continuous operation or S6 intermittent operation with those limit values (respective ON time and duty cycle time) given in the torque-speed operating curves. ²⁾ Minimum cross section of power connection per EN 60 204, sec. 1, table 5, cols. C or E or UL 508 table 50.2, but at least 0.75 mm ² or AWG 18. Cables per UL 508 may only be soldered not crimped to the motor power connector. ³⁾ Data following the slash identify the type of bushing contact as either for crimping or soldering.									

Servo motor MAC ...	Cooling	Motor phase current ¹⁾	Power conn. Min. cross section ¹⁾		Motor power connector		INDRAMAT Motor power cable			
					Crimping Type ³⁾	Soldering type ³⁾	w/o total shield	with total shield	cross section mm ²	
		A	mm ²	AWG ²⁾						
093 A-0-WS	natural convection	9.0	1.0	16	INS 108/02	INS 108/06	INK 250	INK 650	1.5	
093 A-0-PS		12.3	1.5	14	INS 108/02	INS 108/06	INK 250	INK 650	1.5	
093 A-0-LS		18.0	2.5	12	INS 108/03	INS 108/06	INK 202	INK 602	2.5	
093 A-0-HS		26.2	4.0	10	INS 108/04	INS 108/06	INK 203	INK 603	4.0	
093 B-0-OS		14.8	1.5	14	INS 108/02	INS 108/06	INK 250	INK 650	1.5	
093 B-0-JS		22.1	4.0	10	INS 108/04	INS 108/06	INK 203	INK 603	4.0	
093 B-0-GS		31.2	6.0	8	INS 172/06	INS 172/25	INK 204	INK 604	6.0	
093 B-0-ES		44.3	10.0	6	INS 172/10	INS 172/25	INK 205	INK 605	10.0	
093 C-0-KS		18.0	2.5	12	INS 108/03	INS 108/06	INK 202	INK 602	2.5	
093 C-0-FS		28.7	6.0	10	INS 172/06	INS 172/25	INK 204	INK 604	6.0	
093 C-0-DS		39.4	10.0	8	INS 172/10	INS 172/25	INK 205	INK 605	10.0	
093 C-0-CS		49.2	10.0	6	INS 172/10	INS 172/25	INK 205	INK 605	10.0	
093 A--WS		surface cooling	15.1	1.5	12	INS 108/02	INS 108/06	INK 250	INK 650	1.5
093 A--PS			16.4	2.5	12	INS 108/03	INS 108/06	INK 202	INK 602	2.5
093 A--LS			23.0	4.0	10	INS 108/04	INS 108/06	INK 203	INK 603	4.0
093 A--HS			28.0	4.0	10	INS 108/04	INS 108/06	INK 203	INK 603	4.0
093 B--OS	20.5		2.5	10	INS 108/03	INS 108/06	INK 202	INK 602	2.5	
093 B--JS	28.0		4.0	10	INS 108/04	INS 108/06	INK 203	INK 603	4.0	
093 B--GS	43.5		10.0	6	INS 172/10	INS 172/25	INK 205	INK 605	10.0	
093 B--ES	60.7		16.0	4	INS 172/16	INS 172/25	INK 206	INK 606	16.0	
093 C--KS	26.2		4.0	10	INS 108/04	INS 108/06	INK 203	INK 603	4.0	
093 C--FS	41.0		10.0	6	INS 172/10	INS 172/25	INK 205	INK 605	10.0	
093 C--DS	56.6		16.0	4	INS 172/16	INS 172/25	INK 206	INK 606	16.0	
093 C--CS	71.3		25.0	3	INS 172/25	INS 172/25	INK 207	INK 607	25.0	

Continued on next page

¹⁾ Motor phase currents and connection cross sections apply to S1 continuous operation or S6 intermittent operation with those limit values (respective ON time and duty cycle time) given in the torque-speed operating curves.
²⁾ Minimum cross section of power connection per EN 60 204, sec. 1, table 5, cols. C or E or UL 508 table 50.2, but at least 0.75 mm² or AWG 18. Cables per UL 508 may only be soldered not crimped to the motor power connector.
³⁾ Data following the slash identify the type of bushing contact as either for crimping or soldering.

Servo motor MAC ...	Cooling	Motor phase current ¹⁾	Power conn. Min. cross section ¹⁾		Motor power connector		INDRAMAT Motor power cable			
			mm ²	AWG ²⁾	Crimping Type ³⁾	Soldering type ³⁾	w/o total shield	with total shield	cross section mm ²	
										A
112 A-0-Z•	natural convection	11.8	1.5	14	INS 108/02	INS 108/06	INK 250	INK 650	1.5	
112 A-0-V•		15.1	1.5	12	INS 108/02	INS 108/06	INK 250	INK 650	1.5	
112 A-0-L•		25.3	4.0	10	INS 108/04	INS 108/06	INK 203	INK 603	4.0	
112 B-0-P•		17.1	2.5	10	INS 108/03	INS 108/06	INK 202	INK 602	2.5	
112 B-0-L•		21.5	4.0	10	INS 108/04	INS 108/06	INK 203	INK 603	4.0	
112 B-0-G•		33.5	6.0	8	---	INS 108/06	INK 204	INK 604	6.0	
112 C-0-K•		25.3	4.0	10	INS 108/04	INS 108/06	INK 203	INK 603	4.0	
112 C-0-H•		33.5	6.0	8	---	INS 108/06	INK 204	INK 604	6.0	
112 C-0-E•		46.5	10.0	6	INS 172/10	INS 172/25	INK 205	INK 605	10.0	
112 C-0-C•		71.4	25.0	3	---	INS 172/25	INK 207	INK 607	25.0	
112 D-0-H•		34.3	6.0	8	---	INS 108/06	INK 204	INK 604	6.0	
112 D-0-F•		45.7	10.0	6	INS 172/10	INS 172/25	INK 205	INK 605	10.0	
112 D-0-E•		51.4	16.0	4	INS 172/16	INS 172/25	INK 206	INK 606	16.0	
112 A--Z•		surface cooling	14.0	1.5	14	INS 108/02	INS 108/06	INK 250	INK 650	1.5
112 A--V•			18.7	2.5	10	INS 108/03	INS 108/06	INK 202	INK 602	2.5
112 A--L•	33.7		6.0	8	---	INS 108/06	INK 204	INK 604	6.0	
112 B--P•	26.9		4.0	10	INS 108/04	INS 108/06	INK 203	INK 603	4.0	
112 B--L•	35.5		6.0	8	---	INS 108/06	INK 204	INK 604	6.0	
112 B--G•	61.2		16.0	4	INS 172/16	INS 172/25	INK 206	INK 606	16.0	
112 C--K•	40.0		10.0	6	INS 172/10	INS 172/25	INK 205	INK 605	10.0	
112 C--H•	54.7		16.0	4	INS 172/16	INS 172/25	INK 206	INK 606	16.0	
112 C--E•	85.0		25.0	3	---	INS 172/25	INK 207	INK 607	25.0	
112 D--H•	51.4		16.0	4	INS 172/16	INS 172/25	INK 206	INK 606	16.0	
112 D--F•	67.8		16.0	4	INS 172/16	INS 172/25	INK 206	INK 606	16.0	
112 D--E•	83.3		25.0	3	---	INS 172/25	INK 207	INK 607	25.0	

Continued on next page

¹⁾ Motor phase currents and connection cross sections apply to S1 continuous operation or S6 intermittent operation with those limit values (respective ON time and duty cycle time) given in the torque-speed operating curves.

²⁾ Minimum cross section of power connection per EN 60 204, sec. 1, table 5, cols. C or E or UL 508 table 50.2, but at least 0.75 mm² or AWG 18. Cables per UL 508 may only be soldered not crimped to the motor power connector.

³⁾ Data following the slash identify the type of bushing contact as either for crimping or soldering.

Servo motor MAC ...	Cooling	Motor phase current ¹⁾ A	Power conn. Min. cross section ¹⁾		Motor power connector		INDRAMAT Motor power cable			
			mm ²	AWG ²⁾	Crimping Type ³⁾	Soldering type ³⁾	w/o total shield	with total shield	cross section mm ²	
115 A-0-HS	natural convection	21.8	4.0	10	---	INS 172/25	INK 203	INK 603	4.0	
115 A-0-FS		40.0	10.0	8	INS 172/10	INS 172/25	INK 205	INK 605	10.0	
115 B-0-GS		33.5	6.0	8	INS 172/06	INS 172/25	INK 204	INK 604	6.0	
115 B-0-DS		59.0	16.0	4	INS 172/16	INS 172/25	INK 206	INK 606	16.0	
115 C-0-ES		45.1	10.0	6	INS 172/10	INS 172/25	INK 205	INK 605	10.0	
115 C-0-CS		74.6	25.0	3	---	INS 172/25	INK 207	INK 607	25.0	
115 D-0-ES		44.1	10.0	6	INS 172/10	INS 172/25	INK 205	INK 605	10.0	
115 D-0-DS		55.7	16.0	4	INS 172/16	INS 172/25	INK 206	INK 606	16.0	
115 D-0-CS		73.8	25.0	3	---	INS 172/25	INK 207	INK 607	25.0	
115 A--HS		surface cooling	40.0	10.0	8	INS 172/10	INS 172/25	INK 205	INK 605	10.0
115 A--FS			60.0	16.0	4	INS 172/16	INS 172/25	INK 206	INK 606	16.0
115 B--GS			54.1	16.0	6	INS 172/16	INS 172/25	INK 206	INK 606	16.0
115 B--DS	89.0		25.0	2	---	INS 172/25	INK 207	INK 607	25.0	
115 C--ES	71.3		25.0	3	---	INS 172/25	INK 207	INK 607	25.0	
115 D--ES	68.6		25.0	4	---	INS 172/25	INK 207	INK 607	25.0	
115 D--DS	85.3		25.0	2	---	INS 172/25	INK 207	INK 607	25.0	

1) Motor phase currents and connection cross sections apply to S1 continuous operation or S6 intermittent operation with those limit values (respective ON time and duty cycle time) given in the torque-speed operating curves.
2) Minimum cross section of power connection per EN 60 204, sec. 1, table 5, cols. C or E or UL 508 table 50.2, but at least 0.75 mm² or AWG 18. Cables per UL 508 may only be soldered not crimped to the motor power connector.
3) Data following the slash identify the type of bushing contact as either for crimping or soldering.

Fig 9.2: Connector to cable assignment of the power connection

9.3. Power Connector (Motor Power Connector)

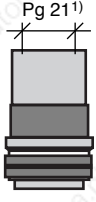
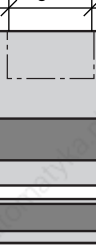
	Crimping types					Soldering types				
	Connector type	Maximum conn. cross section		Strain relief ¹⁾		Connector type	Maximum conn. cross section		Strain relief ¹⁾	
		Power core mm ²	Control core mm ²	Cable type INK	Mat. Nr.		Power core	Control core ²⁾ max.	Cable type INK	Mat. Nr.
INS 108 	INS 108/02	1.5	1.5	250 650	225 404 225 404	INS 108/06	0.75 - 6.0 mm ²	1.5 mm ²	253	260 097
INS 108/03	2.5	1.5	202 602	219 857 227 526	250 202 203 204 653 650 602				225 404 219 857 218 767 218 767 225 404 225 404	
INS 108/04	4.0	1.5	203 603	218 767 218 767	602 603 604				227 526 218 767 218 767	
INS 172 	INS 172/06	6.0	1.5	204 604	220 874 ³⁾ 220 874 ³⁾	INS 172/25	4.0 - 25.0 mm ²	1.5 mm ²	203	220 874 ³⁾
INS 172/10	10.0	1.5	205 605	220 472 ³⁾ 221 554 ³⁾	204 205 206 207 603 604				220 874 ³⁾ 220 472 ³⁾ 220 472 ³⁾ 220 473 220 874 ³⁾	
INS 172/16	16.0	1.5	206 606	220 472 ³⁾ 220 473	605 606 607				220 874 ³⁾ 221 554 ³⁾ 220 473 220 473	

¹⁾ Strain reliefs must be mounted in the conduit thread screws of the motor power connector to ensure a problem-free operation. These are not automatically delivered. The suitable strain reliefs must be ordered from Indramat using the relevant Mat.-Nr. .

²⁾ For motor blocking brake and motor temperature monitoring.

³⁾ Further reduction requires Mat. Nr. 220 474.

Fig 9.3: Motor power connector

9.4. Motor Power Cable

9.4.1. Technical data

Type	Power core cross section mm ²	Control core ¹⁾ cross section mm ²	Total shield	Power cable cross section mm	Minimum bending radius		Weight kg/m
					fixed routing mm	flexible routing mm ²⁾	
INK 253	1.0	0.5	—	10.3 ± 0.3	65	105	0.11
INK 250	1.5	0.75	—	11.4 ± 0.4	90	140	0.19
INK 202	2.5	1.5	—	17.8 ± 0.5	120	200	0.47
INK 203	4.0	1.5	—	18.6 ± 0.5	120	270	0.57
INK 204	6.0	1.5	—	19.8 ± 0.5	120	300	0.67
INK 205	10.0	1.5	—	25.4 ± 0.7	200	380	1.10
INK 206	16.0	1.5	—	26.8 ± 0.7	220	390	1.33
INK 207	25.0	1.5	—	30.5 ± 0.7	240	430	1.70
INK 653	1.0	0.75	+	11.5 ± 0.3	75	100 ²⁾	0.25
INK 650	1.5	0.75	+	12.2 ± 0.4	80	120 ²⁾	0.39
INK 602	2.5	0.75	+	14.8 ± 0.5	85	140 ²⁾	0.59
INK 603	4.0	0.75 or 1.0	+	17.8 ± 0.6	110	180 ²⁾	0.60
INK 604	6.0	0.75 or 1.0	+	19.8 ± 0.6	120	200 ²⁾	0.81
INK 605	10.0	0.75 or 1.0	+	23.8 ± 0.6	150	240 ²⁾	1.10
INK 606	16.0	1.0	+	28.2 ± 0.6	160	280 ²⁾	1.40
INK 607	25.0	1.5	+	31.8 ± 0.8	180	300 ²⁾	1.73

1) For motor blocking brake and motor temperature monitoring.
2) Service life equals 1 000 000 bending loads

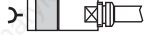

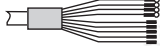
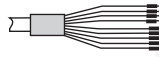

Fig 9.4: Type code dependent data of the motor power cable

9.4.2. General data



Designation	Data
Prot. cat. transition cable to connector	IP 65
Chemical features	absolute resistance to mineral oils and greases, hydrolysis resistant, silicone and halogen free
Permissible ambient temperature range for operation and storage	-30 to + 80 °C
Cable surface	poor adhesion, prevents sticking in drag chains
Cable length	maximum 75 meters

Fig 9.5: General data of the motor power cable

9.4.3. Ready-Made Motor Power Cables

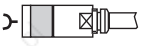
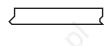
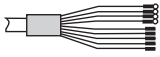
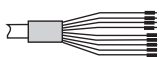
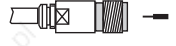
Servo motor MAC ...	Cooling of the motor	Motor power connector 	Motor power cable Type mm ² 		Cable ends for ...			
					Direct connection to drives 	Intermediate terminals to terminal strip 	Intermediate plug- in connection with coupling ¹⁾ 	
063 A-0-ES 063 A-0-RS	natural convection	INS 108/06	INK 253	0.75	IK• 011	IK• 012	IK• 003	
		INS 108/06	INK 253	0.75	IK• 011	IK• 012	IK• 003	
063 B-0-GS 063 B-0-JS		INS 108/06	INK 253	0.75	IK• 011	IK• 012	IK• 003	
		INS 108/06	INK 253	0.75	IK• 011	IK• 012	IK• 003	
063 C-0-MS 063 C-0-HS		INS 108/06	INK 253	0.75	IK• 011	IK• 012	IK• 003	
		INS 108/06	INK 253	0.75	IK• 011	IK• 012	IK• 003	
063 D-0-JS 063 D-0-FS		INS 108/06	INK 253	0.75	IK• 011	IK• 012	IK• 003	
		INS 108/06	INK 253	0.75	IK• 011	IK• 012	IK• 003	
063 A-•-ES 063 A-•-RS		surface cooling	INS 108/06	INK 253	0.75	IK• 011	IK• 012	IK• 003
			INS 108/06	INK 253	0.75	IK• 011	IK• 012	IK• 003
063 B-•-GS 063 B-•-JS			INS 108/06	INK 253	0.75	IK• 011	IK• 012	IK• 003
			INS 108/06	INK 253	0.75	IK• 011	IK• 012	IK• 003
063 C-•-MS 063 C-•-HS	INS 108/06		INK 253	0.75	IK• 011	IK• 012	IK• 003	
	INS 108/06		INK 253	0.75	IK• 011	IK• 012	IK• 003	
063 D-•-JS 063 D-•-FS	INS 108/06		INK 253	0.75	IK• 011	IK• 012	IK• 003	
	INS 108/06		INK 253	0.75	IK• 011	IK• 012	IK• 003	
Continued on next page								
1) For coupling suitable mate: motor power connector								

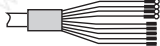
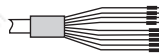
Servo motor MAC ...	Cooling of the motor	Motor power connector 	Motor power cable Type mm ² 		Cable ends for ...			
					Direct connection to drives 	Intermediate terminals to terminal strip 	Intermediate plug- in connection with coupling ¹⁾ 	
071 A-0-HS	natural convection	INS 108/06	INK 253	0.75	IK• 011	IK• 012	IK• 003	
071 A-0-OS		INS 108/06	INK 253	0.75	IK• 011	IK• 012	IK• 003	
071 A-0-ES		INS 108/06	INK 253	0.75	IK• 011	IK• 012	IK• 003	
071 A-0-VS		INS 108/06	INK 253	0.75	IK• 011	IK• 012	IK• 003	
071 B-0-FS		INS 108/06	INK 253	0.75	IK• 011	IK• 012	IK• 003	
071 B-0-TS		INS 108/06	INK 253	0.75	IK• 011	IK• 012	IK• 003	
071 B-0-PS		INS 108/06	INK 253	0.75	IK• 011	IK• 012	IK• 003	
071 B-0-KS		INS 108/02	INK 250	1.5	IK• 021	IK• 022	IK• 023	
071 C-0-US		INS 108/06	INK 253	0.75	IK• 011	IK• 012	IK• 003	
071 C-0-NS		INS 108/06	INK 253	0.75	IK• 011	IK• 012	IK• 003	
071 C-0-JS		INS 108/02	INK 250	1.5	IK• 021	IK• 022	IK• 023	
071 C-0-GS		INS 108/03	INK 202	2.5	IK• 041	IK• 042	IK• 043	
071 A--HS		surface cooling	INS 108/06	INK 253	0.75	IK• 011	IK• 012	IK• 003
071 A--OS			INS 108/06	INK 253	0.75	IK• 011	IK• 012	IK• 003
071 A--ES			INS 108/06	INK 253	0.75	IK• 011	IK• 012	IK• 003
071 A--VS			INS 108/02	INK 250	1.5	IK• 021	IK• 022	IK• 023
071 B--FS	INS 108/06		INK 253	0.75	IK• 011	IK• 012	IK• 003	
071 B--TS	INS 108/02		INK 250	1.5	IK• 021	IK• 022	IK• 023	
071 B--PS	INS 108/02		INK 250	1.5	IK• 021	IK• 022	IK• 023	
071 B--KS	INS 108/03		INK 202	2.5	IK• 041	IK• 042	IK• 043	
071 C--US	INS 108/02		INK 250	1.5	IK• 021	IK• 022	IK• 023	
071 C--NS	INS 108/03		INK 202	2.5	IK• 041	IK• 042	IK• 043	
071 C--JS	INS 108/04		INK 203	4.0	IK• 061	IK• 062	IK• 063	
071 C--GS	INS 108/06		INK 204	6.0	IK• 081	IK• 082	IK• 089	
Continued on next page								
1) For coupling suitable mate: motor power connector								

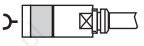
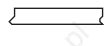
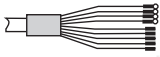
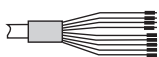
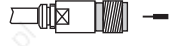

Servo motor MAC ...	Cooling of the motor	Motor power connector 	Motor power cable Type mm ² 		Cable ends for ...		
					Direct connection to drives 	Intermediate terminals to terminal strip 	Intermediate plug- in connection with coupling ¹⁾ 
090 A-0-Z• 090 A-0-R•	natural convection	INS 108/06	INK 253	0,75	IK• 011	IK• 012	IK• 003
		INS 108/02	INK 250	1,5	IK• 021	IK• 022	IK• 023
090 B-0-P•		INS 108/02	INK 250	1,5	IK• 021	IK• 022	IK• 023
090 B-0-N•		INS 108/02	INK 250	1,5	IK• 021	IK• 022	IK• 023
090 B-0-J•		INS 108/02	INK 250	1,5	IK• 021	IK• 022	IK• 023
090 C-0-K•		INS 108/02	INK 250	1,5	IK• 021	IK• 022	IK• 023
090 C-0-G•		INS 108/03	INK 202	2,5	IK• 041	IK• 042	IK• 043
090 C-0-E•		INS 108/06	INK 204	6,0	IK• 081	IK• 082	IK• 089
090 A--Z• 090 A--R•		surface cooling	INS 108/06	INK 253	0,75	IK• 011	IK• 012
	INS 108/02		INK 250	1,5	IK• 021	IK• 022	IK• 023
090 B--P•	INS 108/02		INK 250	1,5	IK• 021	IK• 022	IK• 023
090 B--N•	INS 108/03		INK 202	2,5	IK• 041	IK• 042	IK• 043
090 B--J•	INS 108/04		INK 203	4,0	IK• 061	IK• 062	IK• 063
090 C--K•	INS 108/04		INK 203	4,0	IK• 061	IK• 062	IK• 063
090 C--G•	INS 108/06		INK 204	6,0	IK• 081	IK• 082	IK• 089
090 C--E•	INS 172/10		INK 205	10,0	IK• 121	IK• 122	IK• 128
Continued on next page							
1) For coupling suitable mate: motor power connector							

9. Electrical Power Connection

Servo motor MAC ...	Cooling of the motor	Motor power connector 	Motor power cable Type mm ² 		Cable ends for ...			
					Direct connection to drives 	Intermediate terminals to terminal strip 	Intermediate plug- in connection with coupling ¹⁾ 	
093 A-0-WS	natural convection	INS 108/02	INK 250	1,5	IK• 021	IK• 022	IK• 023	
093 A-0-PS		INS 108/02	INK 250	1,5	IK• 021	IK• 022	IK• 023	
093 A-0-LS		INS 108/03	INK 202	2,5	IK• 041	IK• 042	IK• 043	
093 A-0-HS		INS 108/04	INK 203	4,0	IK• 061	IK• 062	IK• 063	
093 B-0-OS		INS 108/02	INK 250	1,5	IK• 021	IK• 022	IK• 023	
093 B-0-JS		INS 108/04	INK 203	4,0	IK• 061	IK• 062	IK• 063	
093 B-0-GS		INS 172/06	INK 204	6,0	IK• 101	IK• 102	IK• 108	
093 B-0-ES		INS 172/10	INK 205	10,0	IK• 121	IK• 122	IK• 128	
093 C-0-KS		INS 108/03	INK 202	2,5	IK• 041	IK• 042	IK• 043	
093 C-0-FS		INS 172/06	INK 204	6,0	IK• 101	IK• 102	IK• 108	
093 C-0-DS		INS 172/10	INK 205	10,0	IK• 121	IK• 122	IK• 128	
093 C-0-CS		INS 172/10	INK 205	10,0	IK• 121	IK• 122	IK• 128	
093 A--WS		surface cooling	INS 108/02	INK 250	1,5	IK• 021	IK• 022	IK• 023
093 A--PS			INS 108/03	INK 202	2,5	IK• 041	IK• 042	IK• 043
093 A--LS			INS 108/04	INK 203	4,0	IK• 061	IK• 062	IK• 063
093 A--HS			INS 108/04	INK 203	4,0	IK• 061	IK• 062	IK• 063
093 B--OS	INS 108/03		INK 202	2,5	IK• 041	IK• 042	IK• 043	
093 B--JS	INS 108/04		INK 203	4,0	IK• 061	IK• 062	IK• 063	
093 B--GS	INS 172/10		INK 205	10,0	IK• 121	IK• 122	IK• 128	
093 B--ES	INS 172/16		INK 206	16,0	IK• 141	IK• 142	IK• 148	
093 C--KS	INS 108/04		INK 203	4,0	IK• 061	IK• 062	IK• 063	
093 C--FS	INS 172/10		INK 205	10,0	IK• 121	IK• 122	IK• 128	
093 C--DS	INS 172/16		INK 206	16,0	IK• 141	IK• 142	IK• 148	
093 C--CS	INS 172/25		INK 207	25,0	IK• 161	IK• 162	IK• 168	

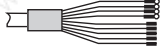
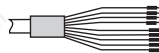

Continued on next page

¹⁾ For coupling suitable mate: motor power connector

Servo motor MAC ...	Cooling of the motor	Motor power connector 	Motor power cable		Cable ends for ...			
			Type	mm ²	Direct connection to drives 	Intermediate terminals to terminal strip 	Intermediate plug- in connection with coupling ¹⁾ 	
112 A-0-Z•	natural convection	INS 108/02	INK 250	1,5	IK• 021	IK• 022	IK• 023	
112 A-0-V•		INS 108/02	INK 250	1,5	IK• 021	IK• 022	IK• 023	
112 A-0-L•		INS 108/04	INK 203	4,0	IK• 061	IK• 062	IK• 063	
112 B-0-P•		INS 108/03	INK 202	2,5	IK• 041	IK• 042	IK• 043	
112 B-0-L•		INS 108/04	INK 203	4,0	IK• 061	IK• 062	IK• 063	
112 B-0-G•		INS 108/06	INK 204	6,0	IK• 081	IK• 082	IK• 089	
112 C-0-K•		INS 108/04	INK 203	4,0	IK• 061	IK• 062	IK• 063	
112 C-0-H•		INS 108/06	INK 204	6,0	IK• 081	IK• 082	IK• 089	
112 C-0-E•		INS 172/10	INK 205	10,0	IK• 121	IK• 122	IK• 128	
112 C-0-C•		INS 172/25	INK 207	25,0	IK• 161	IK• 162	IK• 168	
112 D-0-H•		INS 108/06	INK 204	6,0	IK• 081	IK• 082	IK• 089	
112 D-0-F•		INS 172/10	INK 205	10,0	IK• 121	IK• 122	IK• 128	
112 D-0-E•		INS 172/16	INK 206	16,0	IK• 141	IK• 142	IK• 148	
112 A--Z•		surface cooling	INS 108/02	INK 250	1,5	IK• 021	IK• 022	IK• 023
112 A--V•			INS 108/03	INK 202	2,5	IK• 041	IK• 042	IK• 043
112 A--L•	INS 108/06		INK 204	6,0	IK• 081	IK• 082	IK• 089	
112 B--P•	INS 172/25		INK 203	4,0	IK• 061	IK• 062	IK• 063	
112 B--L•	INS 108/06		INK 204	6,0	IK• 081	IK• 082	IK• 089	
112 B--G•	INS 172/16		INK 206	16,0	IK• 141	IK• 142	IK• 148	
112 C--K•	INS 172/10		INK 205	10,0	IK• 121	IK• 122	IK• 128	
112 C--H•	INS 172/16		INK 206	16,0	IK• 141	IK• 142	IK• 148	
112 C--E•	INS 172/25		INK 207	25,0	IK• 161	IK• 162	IK• 168	
112 D--H•	INS 172/16		INK 206	16,0	IK• 141	IK• 142	IK• 148	
112 D--F•	INS 172/16		INK 206	16,0	IK• 141	IK• 142	IK• 148	
112 D--E•	INS 172/25		INK 207	25,0	IK• 161	IK• 162	IK• 168	

Continued on next page

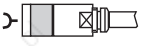
¹⁾ For coupling suitable mate: motor power connector

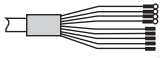
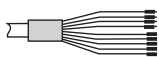
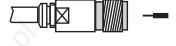
Servo motor MAC ...	Cooling of the motor	Motor power connector 	Motor power cable Type mm ² 		Cable ends for ...			
					Direct connection to drives 	Intermediate terminals to terminal strip 	Intermediate plug- in connection with coupling ¹⁾ 	
115 A-0-HS	natural convection	INS 172/06	INK 204	6,0	IK• 101	IK• 102	IK• 108	
115 A-0-FS		INS 172/10	INK 205	10,0	IK• 121	IK• 122	IK• 128	
115 B-0-GS		INS 172/06	INK 204	6,0	IK• 101	IK• 102	IK• 108	
115 B-0-DS		INS 172/16	INK 206	16,0	IK• 141	IK• 142	IK• 148	
115 C-0-ES		INS 172/10	INK 205	10,0	IK• 121	IK• 122	IK• 128	
115 C-0-CS		INS 172/25	INK 207	25,0	IK• 161	IK• 162	IK• 168	
115 D-0-ES		INS 172/10	INK 205	10,0	IK• 121	IK• 122	IK• 128	
115 D-0-DS		INS 172/16	INK 206	16,0	IK• 141	IK• 142	IK• 148	
115 D-0-CS		INS 172/25	INK 207	25,0	IK• 161	IK• 162	IK• 168	
115 A--HS		surface cooling	INS 172/10	INK 205	10,0	IK• 121	IK• 122	IK• 128
115 A--FS			INS 172/16	INK 206	16,0	IK• 141	IK• 142	IK• 148
115 B--GS			INS 172/16	INK 206	16,0	IK• 141	IK• 142	IK• 148
115 B--DS	INS 172/25		INK 207	25,0	IK• 161	IK• 162	IK• 168	
115 C--ES	INS 172/25		INK 207	25,0	IK• 161	IK• 162	IK• 168	
115 D--ES	INS 172/25		INK 207	25,0	IK• 161	IK• 162	IK• 168	
115 D--DS	INS 172/25		INK 207	25,0	IK• 161	IK• 162	IK• 168	

¹⁾ For coupling suitable mate: motor power connector

Fig 9.6: Types of ready-made motor power cable differentiated by cable end

9.4.4. Order guidelines

Example: IKL 041 / 12.0

Length in meters

L... Standard cable without total shield

G... Cable with total shield

The cable are available in 0.5 meter increments from a length of 5 meters. Shorter lengths available upon request.

10. Electrical Connection Tachofeedback

10.1. Terminal Diagram

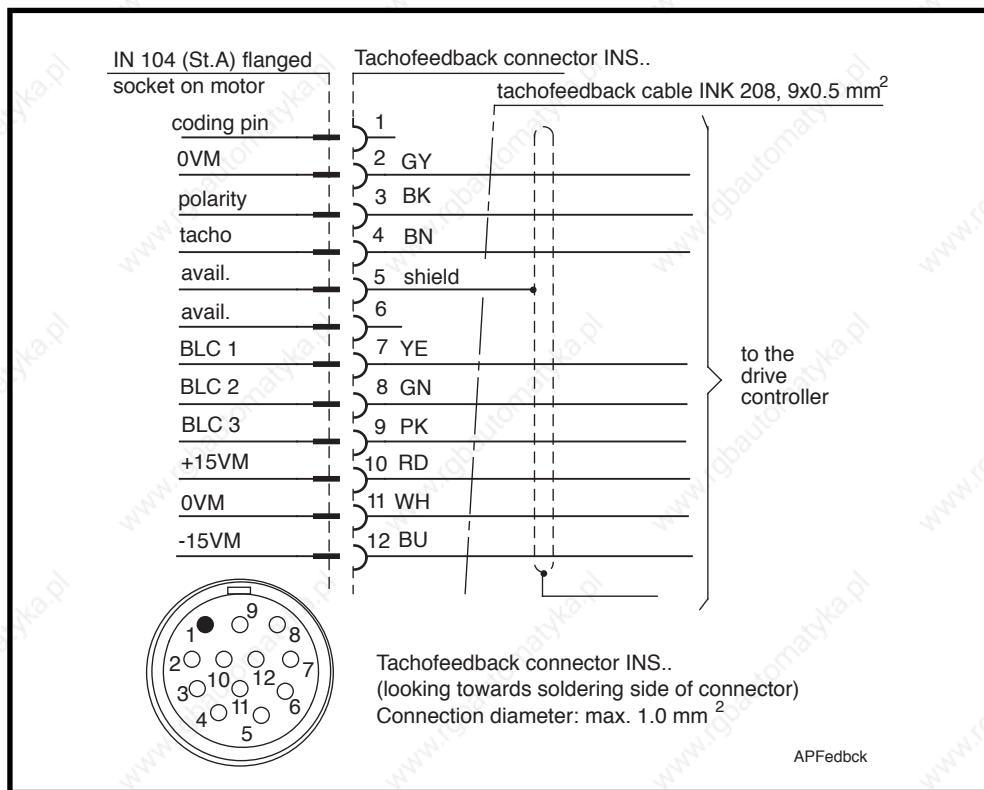

Fig 10.1: Tachofeedback connection

10.2. Tachofeedback Connector

Motor type MAC...	Types of connectors for INDRAMAT cable INK 208		Connector types suitable for cable with external diameter ...	
	straight connector	angle connector	(...6.5 - 9.5 mm) straight connector	(...7.0 - 10.5 mm) angle connector
063...	INS 302 	—	INS 102 	—
071... ¹⁾ 090... ¹⁾ 093... ¹⁾ 112... ²⁾ 115... ²⁾	INS 302 	INS 352 ³⁾ 	INS 102 	INS 312 ³⁾

¹⁾ With axial surface cooling, use straight connectors only.
²⁾ With axial surface cooling, use straight connectors with extension sleeves only (part no. 218277).
³⁾ Do not use with MAC 093 in connection with power connector INS 172, if power connector mounted towards side B.

Fig 10.2: Available tachofeedback connectors











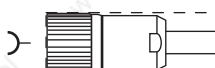

10.3. Tachofeedback Cable

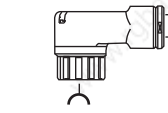
10.3.1. Technical Data

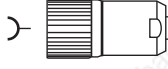
Type designation	INK 208
Prot. cat. transition cable to conn.	IP 65
Cable diameter	8.8 ± 0.3 mm
Minimum bending radius fixed routing	40 mm
Minimum bending radius flexible routing (Service life equals 1,000,000 bend loads)	90 mm
Weight	0.103 kg/m
Permissible ambient temperature for operation and storage	-30 °C to +80 °C
Cable surface	adhesion poor, prevents sticking in drag chains
Chemical characteristics	absolute resistance to mineral oils and greases, hydrolysis resistant, silicone and halogen free
Maximum cable length	75 m

Fig 10.3: Technical data tachofeedback cable INK 208

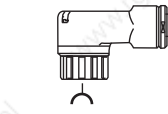
10.3.2. Ready-Made Tachofeedback Cable

Order codes for ready-made tachofeedback cable	Type codes of tachofeedback connector	INDRAMAT tachofeedback cable	Type of cable end
IKS 255	INS 302 	INK 208	INS 317 
IKS 256 ¹⁾	INS 302 with extension sleeve 	INK 208	INS 317  with coupling unit for connecting matching mate INS 302
IKS 261 ^{2) 3)}	INS 352 	INK 208	INS 317 
IKS 251	INS 302 	INK 208	
IKS 252 ¹⁾	INS 302 with extension sleeve 	INK 208	 with ferrules for connecting to terminal strip of drive controller
IKS 259 ^{2) 3)}	INS 352 	INK 208	

¹⁾ with MAC 112 and 115 with axial surface cooling
²⁾ do not use in motors with axial surface cooling
³⁾ do not use in MAC 093 together with INS 172 and mounting orientation side B

MZFEEDBACK

Fig 10.4: Ready-made feedback cable

10.3.3. Order guidelines

Example: IKS 255 / 12.0

length in meters

The ready-made cables are available in increments of 0.5 meters from five meters. Shorter lengths available upon request.

11. Electrical Connection Incremental Encoder

11.1. Terminal Diagram

Encoder with square-wave pulse

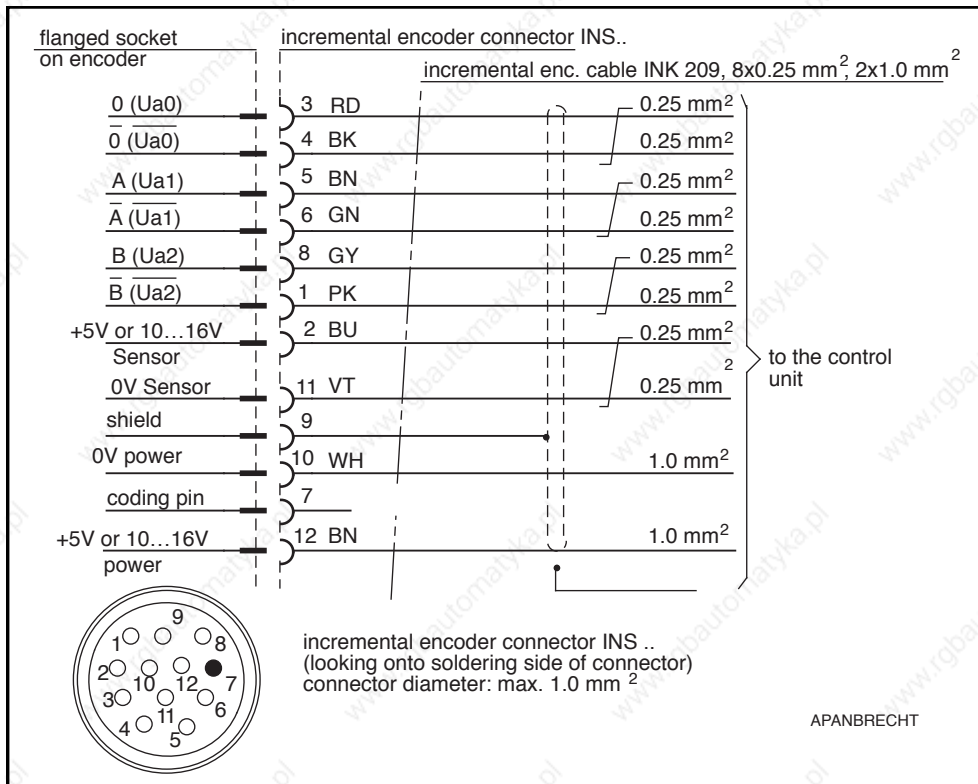

Fig 11.1: Incremental encoder terminal diagram - 5V and 10-16V, square-wave pulse

Encoder with sinusoidal signal

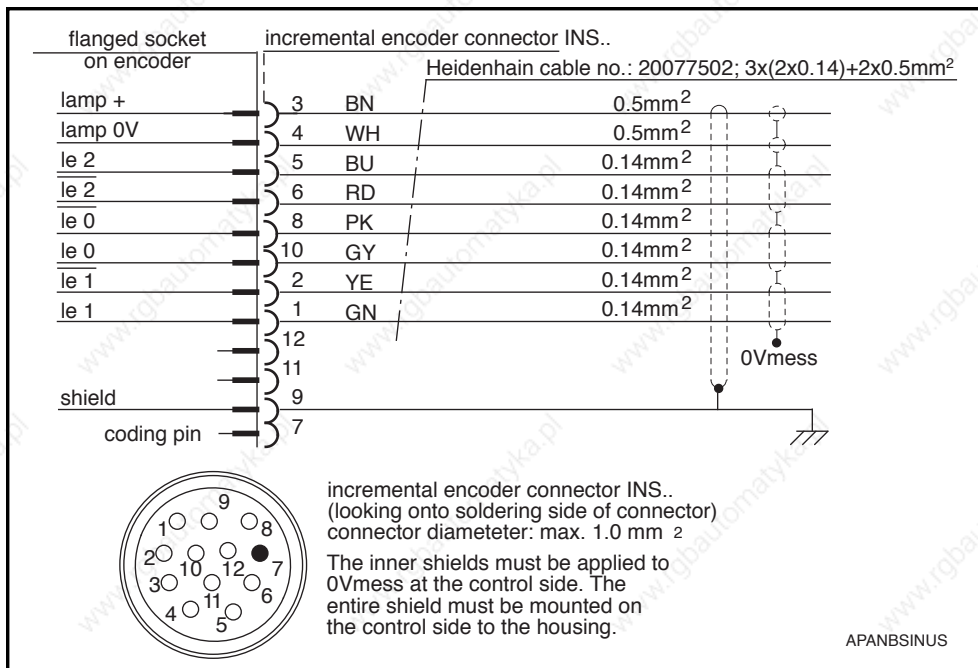

Fig 11.2: Incremental encoder - terminal diagram - sinus signals

11.2. Incremental Encoder Connector





Mototyp MAC...	Types of connectors for INDRAMAT cable INK 209		Connector types suitable for Heidenhain cable or cable with external diameter ...	
	straight connector	angle connector	(...6.5 - 9.5 mm) straight connector	(...7.0 - 10.5 mm) angle connector
063... 071... ¹⁾ 090... ¹⁾ 093... ¹⁾ 112... ²⁾ 115... ²⁾	INS 301 	INS 351 	INS 101 	INS 311 
¹⁾ With axial surface cooling use straight connector only. ²⁾ With axial surface cooling use straight connector with extension sleeve only (part no. 218277).				

Fig 11.3: Available incremental encoder connectors

11.3. Incremental Encoder Cable

11.3.1. Technical Data

INDRAMAT cable



Type designation	INK 209
Prot. cat. transition cable to conn.	IP 65
Cable diameter	8.8 ± 0.3 mm
Minimum bending radius fixed routing	40 mm
Minimum bending radius flexible routing (Service life equals 1,000,000 bend loads)	90 mm
Weight	0.102 kg/m
Permissible ambient temperature for operation and storage	-30 °C to +80 °C
Cable surface	adhesion poor, prevents sticking in drag chains
Chemical characteristics	resistant to mineral oils and greases, hydrolysis resistant, silicone and halogen free
Maximum cable length	50 m

Fig 11.4: Technical data - incremental encoder cable - INK 209

Heidenhain cable

For technical data on the Heidenhain cable, please see the Heidenhain documentation. Maximum cable length equals 50 meters.

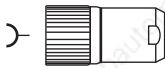
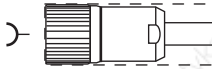
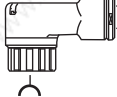
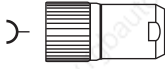
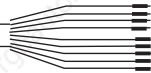
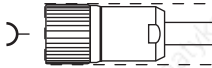
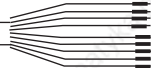
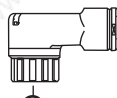
11.3.2. Ready-Made Incremental Encoder Cable for Encoders with Square-Wave Pulses

Order code for ready-made incremental encoder cables	Type codes for incremental encoder connectors	INDRAMAT incremental encoder cable	Type of cable end
IKS 303		INK 209	INS 318
IKS 304 ¹⁾	INS 301 with extension sleeve 	INK 209	INS 318 with coupling unit to connect matching connector INS 301
IKS 309 ²⁾	INS 351 	INK 209	INS 318
IKS 301	INS 301 	INK 209	
IKS 302 ¹⁾	INS 301 with extension sleeve 	INK 209	 with ferrules for connecting to terminal strip ³⁾
IKS 307 ²⁾	INS 351 	INK 209	

¹⁾ in MAC 112 and 115 with axial surface cooling
²⁾ do not use in motors with axial surface cooling
³⁾ avoid because of interference in shield

KonfiNk

Fig 11.5: Ready-made incremental encoder cable for encoders with square-wave pulses

11.3.3. Order guidelines

Example : IKS 301 / 12.0

Length in meters

The ready-made cables are available in increments of 0.5 meters from five meters. Shorter lengths available upon request.

12. Electrical Connection Absolute Encoder

12.1. Terminal Diagram

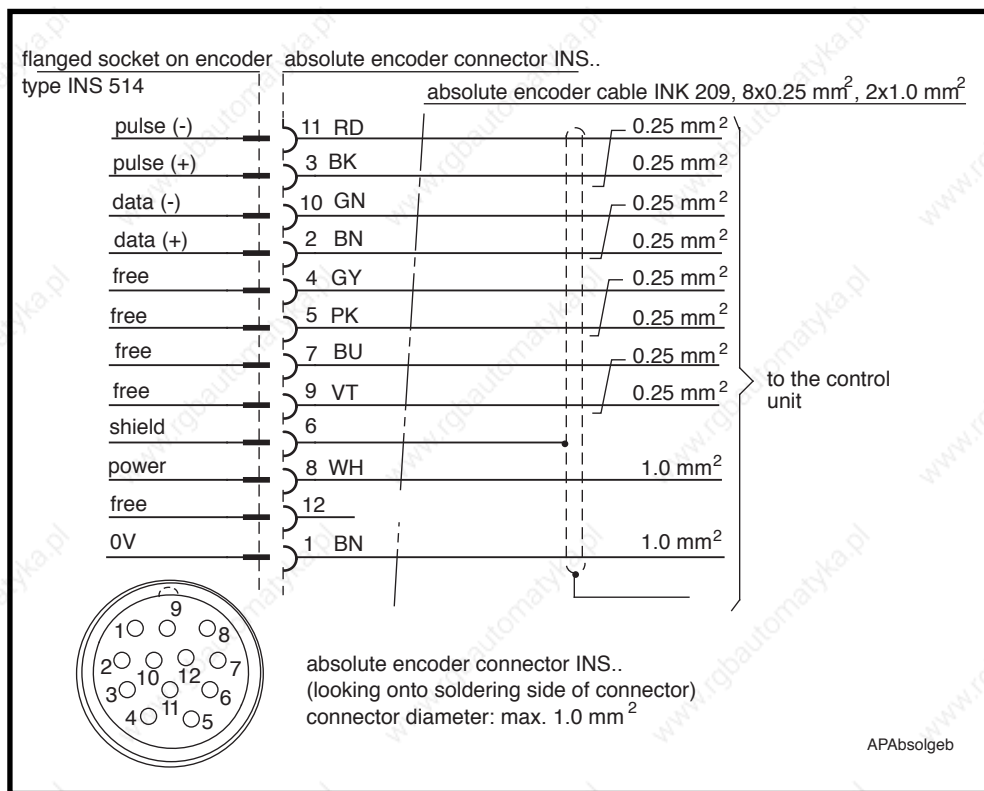

Fig 12.1: Terminal diagram - absolute encoder

12.2. Absolute Encoder Connector

Motor type MAC...	Types of connectors for INDRAMAT cable INK 209		Connector types suitable for cable with external diameter of 6.5 - 9.5 mm
	straight connector	angle connector	straight connector
063... 071... ¹⁾ 090... ¹⁾ 093... ¹⁾ 112... ¹⁾ 115... ¹⁾	INS 326 	INS 322 	INS 092
¹⁾ Can be used with axial surface cooling straight connector.			

Fig 12.2: Available absolute encoder connectors

12.3. Absolute Encoder Cable

12.3.1. Technical Data

Type designation	INK 209
Prot. cat. transition cable to connector	IP 65
Cable cross section	8.8 ± 0.3 mm
Minimum bending radius fixed routing	40 mm
Minimum bending radius flexible routing (Service life equals 1,000,000 bend loads)	90 mm
Weight	0.102 kg/m
Permissible ambient temperature for operation and storage	-30 °C to +80 °C
Cable surface	adhesion poor, prevents sticking in drag chains
Chemical characteristics	resistant to mineral oils and greases, hydrolysis resistant, silicone and halogen free
Maximum cable length	100 m

Fig 12.3: Technical data absolute encoder cable INK 209

12.3.2. Ready-Made Absolute Encoder Cables

Order code for ready-made absolute encoder cable	Type code of absolute encoder connector	INDRAMAT absolute encoder cable	Type of cable end
IKS 724	INS 326	INK 209	INS 292
IKS 729 ¹⁾	INS 322	INK 209	INS 292
IKS 806	INS 326	INK 209	INS 327
IKS 807 ¹⁾	INS 322	INK 209	INS 327
IKS 801	INS 326	INK 209	with ferrules to connect to terminal strip ²⁾
IKS 805 ¹⁾	INS 322	INK 209	with ferrules to connect to terminal strip ²⁾

plug-in connector 25-pin D-Sub to connect to CLM

with coupling unit for connecting to matching connector INS 326

with ferrules to connect to terminal strip ²⁾

¹⁾ do not use in motors with axial surface cooling
²⁾ avoid due to interference in shield

MZFEEBACK

Fig 12.4: Ready-made absolute encoder cables

12.3.3. Order guidelines

Example : IKS 801 / 12.0

Length in meters

The ready-made cables are available in increments of 0.5 meters from five meters. Shorter lengths available upon request.

13. Guidelines on Routing Encoder Cables

Past experiences in the industry have shown that the design of an installation can be of significant importance for the interference-free transmission of encoder signals. The following should be noted with respect to the routing of the cables:

- Route the cables with shielding and separately of the load voltage lines and mains control lines.
- If the encoder cables are routed parallel to the motor cables, then maintain a minimum distance of 100 mm or equip with a metallic partition to the service cable.
- The shield of the encoder cable should be applied to the NC in the encoder connector.
- The shield may not be applied on the housing but on the motor. The encoders are insulated against the servo motor. This prevents earth loops.
- Neither pull out nor insert the connector while voltage is being applied.

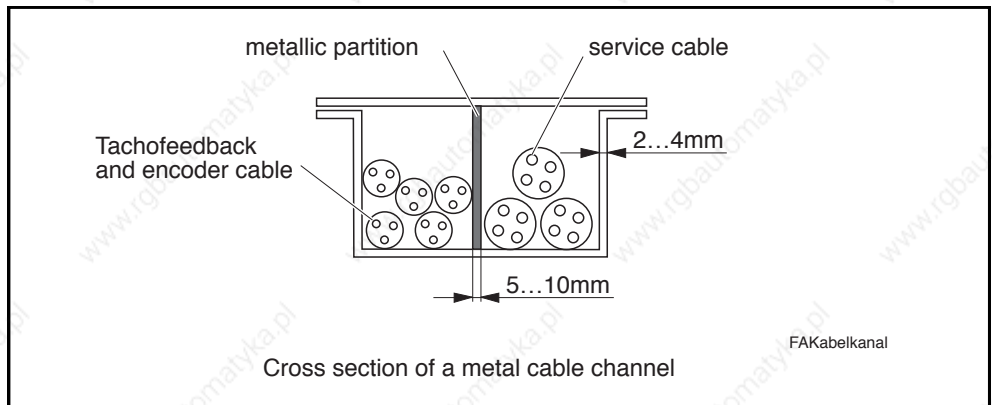

Fig 13.1: Example of a metallic partition of the control cables to prevent interference from power cables.

14. Condition at Delivery

The motors are packed onto a palette or in cartons at the time of delivery. The way they are packed depends upon the numbers and/or sizes of the motor.

If a single motor is packed on a palette, then it is secured against sliding and movement by means of a squared timbers, and then tightly lashed into place with taut metal bands. If several motors are simultaneously delivered, then up to three motors will be on one palette. Pieces of styrofoam or cartons are then used to prevent them from damaging each other.

To prevent damage from inclement weather, a carton is palced over a palette and then affixed to the palette with the use of taut bands.

To unpack without damaging the items, simply cut through the taut bands.



Caution! There is tension in the taut bands!

There exists the danger of injury from uncontrolled lashing out of the taut bands!

Maintain sufficient distance! Cut taught bands open carefully!

There is an envelope containing the delivery slip attached to the carton.

There is also a barcode sticker, or stickers depending on the extent of the delivery, listing the following information:

- type designation of the motor
- customer
- delivery slip number
- consignment
- name of delivering agent

For additional information, please see section 15, "Identifying the Merchandise".

There is no further documentation accompanying the delivery unless specifically requested.

15. Identifying the Merchandise

Only one delivery slip accompanies the entire delivery. This slip lists the merchandise in terms of its name and order designations. In the event that some of the listed items are distributed over several cartons or transport containers, then this will be noted in the delivery or freight slip.

Barcode Sticker There is a barcode sticker on the packaging of the motor. If several motors are in one carton or container, then there is a sticker for each motor.

The sticker helps to identify the contents of the cartons and is required to complete the order procedure at Indramat.

The following information is on the sticker:

- type designation of the motor
- customer
- delivery slip number
- consignment
- name of the delivering agent



Fig 15.1: An example of a barcode sticker

Rating Plate The motor is delivered with a rating plate which is attached to the motor housing.

If a second rating plate is ordered, then it is placed over the original one with double-sided tape. Both are on the housing of the motor.

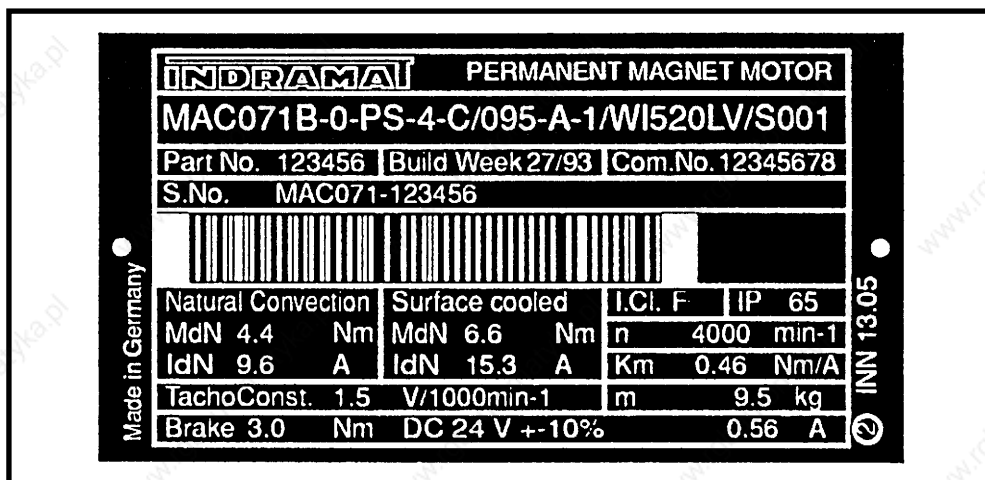

Fig 15.2: Example of a rating plate of a MAC AC servo motor per DIN 42961

16. Storage, Transport and Handling

There are guidelines on storage and transportation printed on the carton. These must be followed.



Fig 16.1: Guidelines on storage and transport on packaging

Storing the Motors

The motors must be stored in a dry, dust-free and shock-free environment.

Permissible ambient temperature range: -25 °C to + 85 °C.

There are protective covers on the connector housing as well as the output shaft. These are made of plastic and protect the parts they cover against moisture and damage. Do not remove the protective covers until shortly prior to mounting into the machine.

Transport and Handling

Avoid impacts to the output shaft and heavy loads as otherwise the bearings in the motor could be damaged.

Note the different weights and sizes of the individual types of motors when selecting both the transport and lifting devices.



Do not pick up the motor at the blower. This will damage and possibly tear the blower off of the motor housing.

Figure 16.2 depicts how the heavy motors should be picked up with the help of a crane and belts. It is important that no load be applied to either output shaft or blower housing during this procedure!

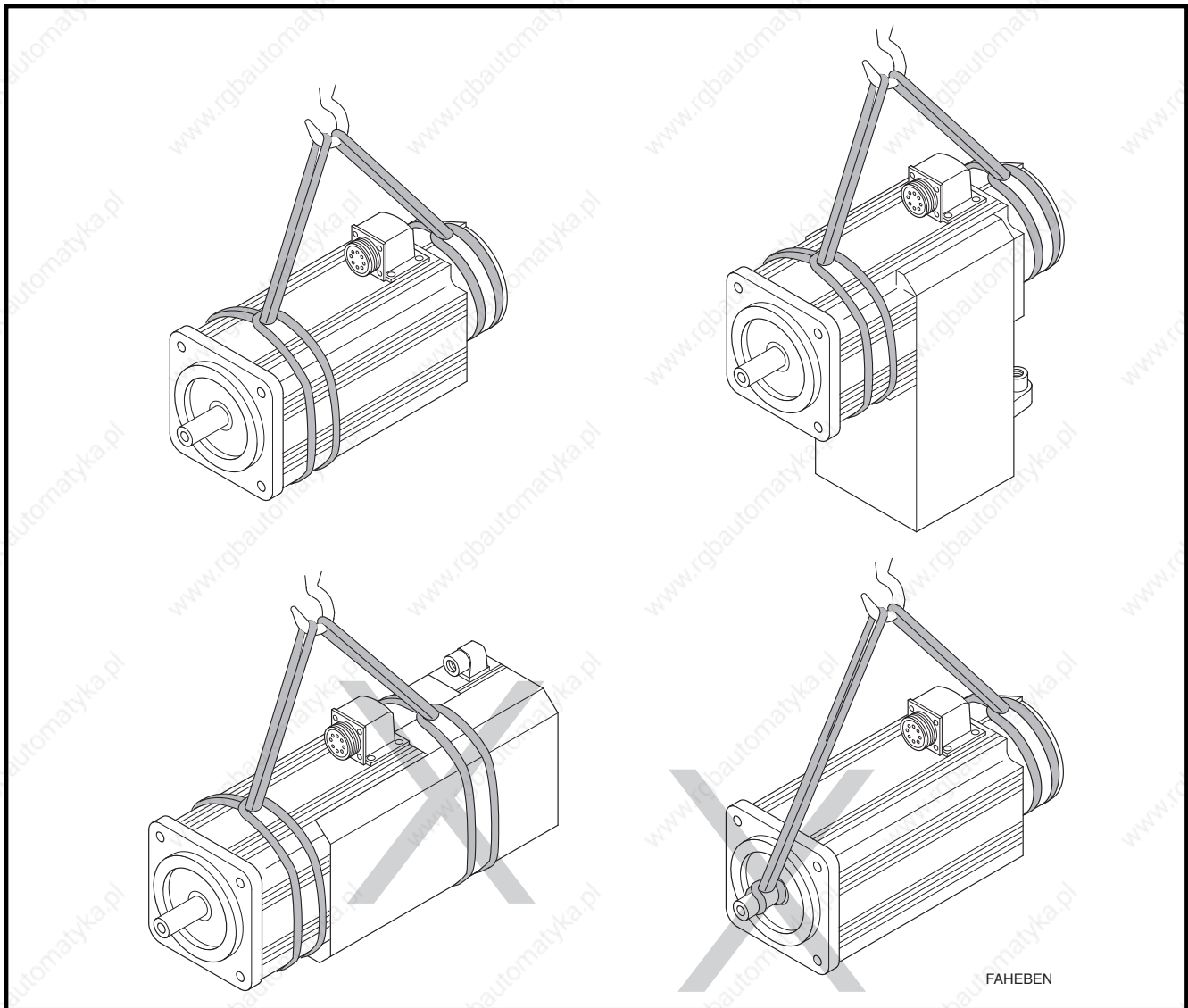

Fig 16.2: Picking up and transporting the motors with the help of the crane belts

There are two M8 tapped holes in the housing of the MAC 112 and MAC 115 line of motors. Lifting screws, per DIN 580, can be screwed into place here. These can then be used for holding the motor in place by a suitable lifting device. The hooks of a chain tackle can, for example, be hooked into place here. See Figure 16.3 for illustration.

INDRAMAT does not automatically deliver these lifting hooks with the motor. The user must, therefore, supply them.



If an axial surface cooling blower is mounted to MAC 112 or 115 motors, then these may only be picked up by the lifting hooks.

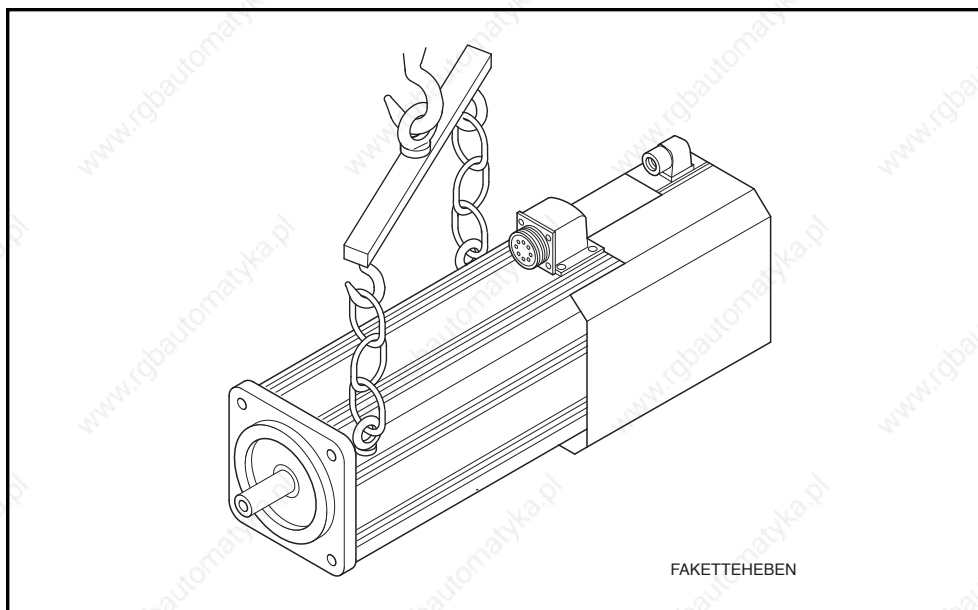

Fig 16.3: Picking up and transporting the MAC 112 and 115 series with chain tackle

17. Mounting and Installation Guidelines

The following guidelines must be followed to avoid damaging the machine when mounting or commissioning:

- The bigger and thus heavier motors may only be transported with the use of suitable lifting devices as described in the guidelines of section 16.
- Avoid impacts to the output shaft and heavy loads at the shaft as otherwise the bearings within the motor could be damaged.
- The motors should only be mounted to the machine by fully trained personnel.
- The spigot nuts on the connectors, e.g., motor power and feedback connectors, must be tightly screwed into place when connecting.
- The motor must be grounded to the drive amplifier.
- The terminal diagrams of the machine manufacturer should be followed when wiring the motor!
- Check the reference point settings when replacing motors (see section 2.4, "Motor feedback").
- The guidelines on cable routing are outlined in section 1.3.
- The guidelines on connecting the motor blower are outlined in section 2.3.

18. Service Notes

18.1. Contacting Customer Service

INDRAMAT customer service can be contacted at the following Service Hotline numbers during the times listed:

Service Hotline Phone number: 0172-6600406 or 0171-3338826

Monday - Friday 7.00 a.m. to 11.00 p.m. MET

Saturday 8.00 a.m. to 8.00 p.m. MET

Sundays and holidays 9.00 a.m. to 7.00 p.m. MET

We would appreciate your noting the following information prior to contacting Indramat customer service:

- type data of motor and drive
- the problem
- all fault and diagnostics displays

This will make it possible to quickly and definitively locate the problem.

When returning a motor, please include a copy of the repair card on the next page. Fill it out and send it in. This will enable us to locate the problem caused by their particular application.

18.2. Repair Card

Repair Card for INDRAMAT equipment and components			
Name:		Company/Location:	
Date:			
Part number for exchange of single parts		SN:	Consignment no.:
		SN:	Delivery date:
Machine manufacturer/co.:	Type:	Machine no.:	Commissioning date:
Failure in axis:	<input type="checkbox"/> horizontal <input type="checkbox"/> vertical <input type="checkbox"/>	Operating time:	Date fault occurred:
Fault: Fault _____ _____ <input type="checkbox"/> constantly present <input type="checkbox"/> occurs sporadically <input type="checkbox"/> occurs after _____ hrs. <input type="checkbox"/> occurs with shocks <input type="checkbox"/> depends on temperature <input type="checkbox"/> other _____ _____ _____	Additional data: (e.g., LED diagnosis, error in display) _____ _____ _____ _____ _____ _____ _____	Cause of fault: <input type="checkbox"/> unknown <input type="checkbox"/> connection fault <input type="checkbox"/> external short circuit <input type="checkbox"/> mechanical damage <input type="checkbox"/> loose cable(s) <input type="checkbox"/> other _____ _____ _____	
Additional Data			
General data: <input type="checkbox"/> no function <input type="checkbox"/> drive not running smoothly <input type="checkbox"/> uncontrolled drive motions <input type="checkbox"/> error in one direction only <input type="checkbox"/> supply unit short-circuit fault <input type="checkbox"/> other	Concomitant phenomena: <input type="checkbox"/> Problems in mechanical sys. <input type="checkbox"/> Mains failure <input type="checkbox"/> Control failure <input type="checkbox"/> Motor failure <input type="checkbox"/> Break in cable <input type="checkbox"/> other	Drive, supply unit, amplifier, power section <input type="checkbox"/> control voltage faulty <input type="checkbox"/> power sect. circuit breaker F ____ <input type="checkbox"/> blower defective <input type="checkbox"/> bleeder resistor defective <input type="checkbox"/> power voltage faulty <input type="checkbox"/> connecting bolt broke <input type="checkbox"/> other	
Control: <input type="checkbox"/> no function <input type="checkbox"/> display failed <input type="checkbox"/> no command value output <input type="checkbox"/> diagnosis <input type="checkbox"/> dim. offset in _____ direction <input type="checkbox"/> E-stop loop interrupted <input type="checkbox"/> position control loop won't close <input type="checkbox"/> program sequence fault <input type="checkbox"/> interior auxiliary function faulty (outputs) <input type="checkbox"/> acknowledgements not accepted (inputs) <input type="checkbox"/> other _____ _____	Motor: <input type="checkbox"/> thermo switch defective <input type="checkbox"/> brake defective <input type="checkbox"/> blower defective <input type="checkbox"/> feedback defective <input type="checkbox"/> tachometer signal faulty <input type="checkbox"/> BLC-signal faulty <input type="checkbox"/> short-circuit to ground <input type="checkbox"/> thermal overload <input type="checkbox"/> other _____ _____ _____	Comments: _____ _____ _____ _____ _____ _____	

PIRepBegI

Fig 18.1: Repair card

19. Index

A

Absolute Encoder 34
Absolute Encoder Cable 177
Absolute Encoder Connector 176
Ambient mechanical conditions 14
Ambient temperatures 12
Angle connector 21
Applications 7
Axial surface cooling 17

B

Barcodesticker 181

C

Centering / pilot diameter 16
Condition at Delivery 180
Connection Incremental Encoder 173
Connection Tachofeedback 170
Connector-Cable Allocations 156
Construction 15
Cooling 10, 17

E

Electrical Connection Absolute Encoder 176
Electrical connections 11
Electrical Power Connection 155

F

Feedback 21
Feedback connection 23

G

Guidelines on Cable Routing 179

H

Holding brake 11, 19
Housing coat 15
How to order 169

I

Identifying the Merchandise 181
Incremental Encoder Cable 174
Incremental Encoder Connector 174
Incremental Encoders 28
Installation 10
Installation elevation 12

L

Limiting value for speed 39
Limiting value for torque 39

M

MAC 063 42
MAC 071 59

MAC 090 80
MAC 093 97
MAC 112 118
MAC 115 137
Motor 25
Motor blower connection 23
Motor feedback 9
Motor Power Cable 163
Motor Power Connector 162
Motor power connectors 23
Mounted Encoder 27
Mounted encoder 9
Mounting and Installation Guidelines 186
Mounting orientation 15
Mounting the absolute encoder 37

O

Operating reliability 10
Output shaft 11, 16
Output shaft with keyway 16

P

Performance data 10
Permissible shaft load 17
Plain output shaft 16
Power connection 20, 23
Power levels 8
Protection category 12

R

Radial surface cooling 18
Rating Plate 182
Ready-Made Absolute Encoder Cables 178
Ready-Made Incremental Encoder Cable for Encoders with Square-Wave
Pulses 175
Ready-Made Motor Power Cables 164
Ready-Made Tachofeedback Cable 172
Repair Report Card 188
Replacing the encoder 36

S

Second Shaft End 26
Service Notes 187
Service-Hotline 187
Setting the reference point 32
Setting the reference point of the absolute encoder 38
Shaft sealing 17
Smooth run qualities 11
Storage, Transport and Handling 183
Straight connector 21
Structure 9

T

Tachofeedback 9, 25, 26
Tachofeedback Cable 171
Tachofeedback Connector 170

Terminal Diagram	155
Terminal diagram	22
Thermal deformations	17
Torque-Speed Characteristics	39

