

YH 10

Series Plum Flexible Spring Coupling

YH 10 series plum flexible spring coupling, which adopt the expansion sleeve connection, is of zero backlash and high density. It can transfer big torque. Furthermore, the characteristics are quite same when it run in a clock-wise or anti clock-wise rotation. so it can absorb the vibration, compensate for radial, angle and axial deviation, it usually used in the connection of servo motor, stepper motor, etc.

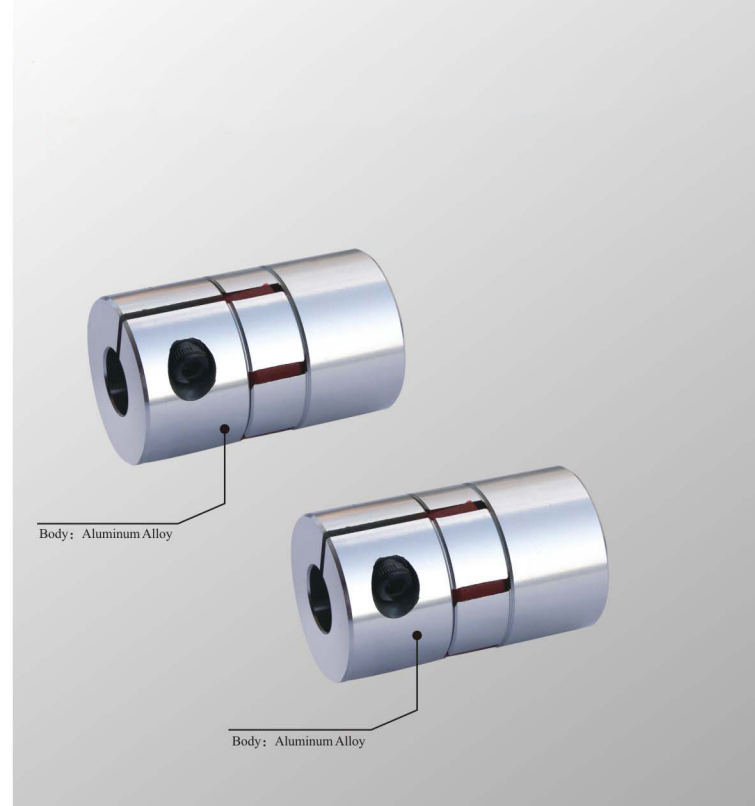

For example: YH10-55-19-24-78 (mm)

YH 10 series no, Aluminum material

Outside diam: $\phi D=55\text{mm}$

d1 bore: $\phi d1=19\text{mm}$

d2 bore: $\phi d2=24\text{mm}$

Length $L=78\text{mm}$



Size of coupling

Parameters of coupling

Model	$\phi d1$ $\phi d2$ Bore	ϕD	L	L1	W	M	Tighten torque (N. m)
YH10-20 □□□□	4 5 6 8 9 10	20	30	10	10	M3	1.1
YH10-30 □□□□	8 9 10 12 14	30	50	18.5	13	M4	1.3
YH10-40 □□□□	11 12 14 16 19 20	40	66	25	16	M5	2.7
YH10-46 □□□□	16 18 20 22 24 25	46	70	28	17	M6	4.5
YH10-55 □□□□	14 16 19 24 25 28	55	78	30	18	M8	6.0
YH10-65 □□□□	19 20 24 28 30 35 38	65	90	35	20	M8	6.0
YH10-80 □□□□	24 28 30 35 38 40 45	80	114	45	24	M8	10.0
YH10-95 □□□□	30 35 38 40 45 50	95	126	50	26	M8	35
YH10-105 □□□□	35 40 45 50 55 60	105	140	56	28	M8	35

Model	Rated torque (N.m)	Max torque (N.m)	Max speed (rpm)	Inertia torque (kg.m ²)	Static torque rigidity (n.m/rad)	Radial deviation (mm)	Angular deviation ($^{\circ}$)	Axial deviation (mm)	Weight (g)
YH10-20 □□□□	7.4	14.8	20000	8.7×10^{-4}	510	0.02	1	± 0.06	50
YH10-30 □□□□	7.4	14.8	20000	8.7×10^{-4}	510	0.02	1	± 0.06	50
YH10-40 □□□□	9.5	19.0	15000	1.12×10^{-3}	550	0.02	1	± 0.08	120
YH10-46 □□□□	20	40	14000	3.2×10^{-3}	1510	0.02	1	± 0.08	280
YH10-55 □□□□	34	68	13000	4.5×10^{-3}	1510	0.02	1	± 0.08	280
YH10-65 □□□□	95	190	10500	9.1×10^{-3}	2800	0.02	1	± 0.08	450
YH10-80 □□□□	135	270	8600	1.9×10^{-2}	3600	0.02	1	± 0.08	960
YH10-95 □□□□	230	460	7500	2.2×10^{-1}	4700	0.02	1	± 1.00	2310
YH10-95 □□□□	380	760	6000	3.3×10^{-1}	5800	0.02	1	± 1.00	3090

note: The calculation of Inertia torque and weight is based on the max bore.