

Re-engineered AC SERVOPACK USER'S MANUAL

CACR-SR□□BF SERVOPACK



YASKAWA

YASKAWA ELECTRIC ENGINEERING CORPORATION

MANUAL NO. KG22E

Copyright © 2004 YASKAWA ELECTRIC ENGINEERING CORPORATION

All rights reserved. No part of this publication may be reproduced, stored in a retrieval system, or transmitted, in any form, or by any means, mechanical, electronic, photocopying, recording, or otherwise, without the prior written permission of Yaskawa Electric Engineering. No patent liability is assumed with respect to the use of the information contained herein. Moreover, because Yaskawa Electric Engineering is constantly striving to improve its high-quality products, the information contained in this manual is subject to change without notice. Every precaution has been taken in the preparation of this manual. Nevertheless, Yaskawa Electric Engineering assumes no responsibility for errors or omissions. Neither is any liability assumed for damages resulting from the use of the information contained in this publication.

About this manual

■ Description of Technical Terms

The terms in this manual are defined as follows:

- Re-engineered AC SERVOPACK:
The SERVOPACKs that have been developed to be used for replacement of the conventional SERVOPACK models prior to Σ series.
- CACR-SR□□BF1□:
The re-engineered AC SERVOPACK model designation. The code in □ differs depending on the SERVOPACK capacity and specifications. Refer to 2.2 *SERVOPACK Model Designations*.

■ Quick access to your required information

Read the chapters marked with ✓ to get the information required for your purpose.

Chapter	SERVOPACKs, Servomotors, and Peripheral Devices	Ratings and Characteristics	Panel Configuration and Wiring	Trial Operation	Maintenance and Inspection
Chapter 1 Outline	✓				
Chapter 2 Specifications and Dimensional Drawings	✓	✓	✓		
Chapter 3 Wiring	✓	✓	✓	✓	
Chapter 4 Settings and Display				✓	
Chapter 5 Maintenance, Inspection, and Alarm/Warning Display					✓

■ Related Manuals

Refer to the following manuals as required.

Manual Name	Manual Number	Contents
Σ -III Series SGM□S/SGDS Digital Operator Operation Manual	TOBPS80000001	Provides detailed information on the operation of the JUSP-OP05A Digital Operator.
Σ -III Series SGM□S/SGDS User's Manual	SIEPS80000000	Describes the following items of Σ -III Series SERVOPACKs and Servomotors. <ul style="list-style-type: none"> • Selection of model and capacity • Ratings, characteristics, and dimensional drawings • Cables and peripheral devices • Panel configuration and wiring • Trial operation, servo adjustment, and functions • Inspection, maintenance, and troubleshooting

Safety Information

The following conventions are used to indicate precautions in this manual. Failure to heed precautions provided in this manual can result in serious or possibly even fatal injury or damage to the products or to related equipment and systems.



Indicates precautions that, if not heeded, could possibly result in loss of life or serious injury.



Indicates precautions that, if not heeded, could result in relatively serious or minor injury, damage to the product, or faulty operation.

In some situations, the precautions indicated could have series consequences if not heeded.





Indicates prohibited actions that must not be performed. For example, this symbol would be used to indicate that fire is prohibited as follows: .



Indicates compulsory actions that must be performed. For example, this symbol would be used as follows to indicate that grounding is compulsory: .

The warning symbols for ISO and JIS standards are different, as shown below.

ISO	JIS
	

The ISO symbol is used in this manual.

Both of these symbols appear on warning labels on Yaskawa Electric Engineering products. Please abide by these warning labels regardless of which symbol is used.

Notes for Safe Operation

Read this manual thoroughly before checking products on delivery, storage and transportation, installation, wiring, operation and inspection, and disposal of the AC servo drives.

WARNING

- Never touch any rotating motor parts while the motor is running.
Failure to observe this warning may result in injury.
- Before starting operation with a machine connected, make sure that an emergency stop can be applied at any time.
Failure to observe this warning may result in injury.
- Never touch the inside of the SERVOPACKs.
Failure to observe this warning may result in electric shock.
- Do not touch terminals for five minutes after the power is turned OFF.
Residual voltage may cause electric shock.
- Do not touch terminals for five minutes after voltage resistance test.
Residual voltage may cause electric shock.
- Follow the procedures and instructions for trial operation precisely as noted in this Manual.
- Follow the procedures and instructions for the trial operation as noted in the applicable manual for that product.
Malfunctions that occur after the servomotor is connected to the equipment not only damage the equipment, but may also cause an accident resulting in death or injury.
- Do not remove the front cover, cables, connectors, or optional items while the power is ON.
Failure to observe this warning may result in electric shock.
- Installation, disassembly, or repair must be performed only by authorized personnel.
Failure to observe this warning may result in electric shock or injury.
- Do not damage, press, exert excessive force or place heavy objects on the cables.
Failure to observe this warning may result in electric shock, stopping operation of the product, or burning.
- Provide an appropriate stopping device on the machine side to ensure safety. A holding brake for a servomotor with brake is not a stopping device for ensuring safety.
Failure to observe this warning may result in injury.
- Do not come close to the machine immediately after resetting momentary power loss to avoid an unexpected restart. Take appropriate measures to ensure safety against an unexpected restart.
Failure to observe this warning may result in injury.
- Do not modify the product.
Failure to observe this warning may result in injury or damage to the product.
- Connect the ground terminal to electrical codes (ground resistance: 100 Ω or less).
Improper grounding may result in electric shock or fire.



■ Checking on Delivery

CAUTION

- Always use the servomotor and SERVOPACK in one of the specified combinations.
Failure to observe this caution so may result in fire or malfunction.

■ Storage and Transportation

CAUTION

- Do not store or install the product in the following places.
 - Locations subject to direct sunlight.
 - Locations subject to temperatures outside the range specified in the storage/installation temperature conditions.
 - Locations subject to humidity outside the range specified in the storage/installation humidity conditions.
 - Locations subject to condensation as the result of extreme changes in temperature.
 - Locations subject to corrosive or flammable gases.
 - Locations subject to dust, salts, or iron dust.
 - Locations subject to exposure to water, oil, or chemicals.
 - Locations subject to shock or vibration.Failure to observe this caution may result in fire, electric shock, or damage to the product.
- Do not hold the product by the cables or motor shaft while transporting it.
Failure to observe this caution may result in injury or malfunction.
- Do not place any load exceeding the limit specified on the packing box.
Failure to observe this caution may result in injury or malfunction.

■ Installation

CAUTION

- Never use the products in an environment subject to water, corrosive gases, inflammable gases, or combustibles.
Failure to observe this caution may result in electric shock or fire.
- Do not step on or place a heavy object on the product.
Failure to observe this caution may result in injury.
- Do not cover the inlet or outlet ports and prevent any foreign objects from entering the product.
Failure to observe this caution may cause internal elements to deteriorate resulting in malfunction or fire.
- Be sure to install the product in the correct direction.
Failure to observe this caution may result in malfunction.
- Provide the specified clearances between the SERVOPACK and the control panel or with other devices.
Failure to observe this caution may result in fire or malfunction.
- Do not apply any strong impact.
Failure to observe this caution may result in malfunction.

■ Wiring

CAUTION

- Do not connect a three-phase power supply to the U, V, or W output terminals.
Failure to observe this caution may result in injury or fire.
- Securely connect the power supply terminal screws and motor output terminal screws.
Failure to observe this caution may result in fire.
- Do not bundle or run power and signal lines together in the same duct. Keep power and signal lines separated by at least 30 cm (11.81 in).
- Use twisted-pair shielded wires or multi-core twisted pair shielded wires for signal and encoder (PG) feedback lines.
The maximum length is 3 m (118.11 in) for reference input lines and is 20 m (787.40 in) for PG feedback lines.
- Do not touch the power terminals for 5 minutes after turning power OFF because high voltage may still remain in the SERVOPACK.
Make sure the charge indicator is out first before starting an inspection.
- Avoid frequently turning power ON and OFF. Do not turn power ON or OFF more than once per minute.
Since the SERVOPACK has a capacitor in the power supply, a high charging current flows for 0.2 seconds when power is turned ON. Frequently turning power ON and OFF causes main power devices like capacitors and fuses to deteriorate, resulting in unexpected problems.
- Be sure to wire correctly and securely.
Failure to observe this caution may result in motor overrun, injury, or malfunction.
- Always use the specified power supply voltage.
An incorrect voltage may result in burning.
- Take appropriate measures to ensure that the input power supply is supplied within the specified voltage fluctuation range. Be particularly careful in places where the power supply is unstable.
An incorrect power supply may result in damage to the product.
- Install external breakers or other safety devices against short-circuiting in external wiring.
Failure to observe this caution may result in fire.
- Take appropriate and sufficient countermeasures for each when installing systems in the following locations.
Failure to observe this caution may result in damage to the product.
 - Locations subject to static electricity or other forms of noise.
 - Locations subject to strong electromagnetic fields and magnetic fields.
 - Locations subject to possible exposure to radioactivity.
 - Locations close to power supplies.
- Do not reverse the polarity of the battery when connecting it.
Failure to observe this caution may damage the battery or cause it to explode.

■ Operation

CAUTION

- Conduct trial operation on the servomotor alone with the motor shaft disconnected from machine to avoid any unexpected accidents.
Failure to observe this caution may result in injury.
- Before starting operation with a machine connected, change the settings to match the parameters of the machine.
Starting operation without matching the proper settings may cause the machine to run out of control or malfunction.
- Forward run prohibited (P-OT) and reverse run prohibited (N-OT) signals are not effective during JOG mode operation using parameter Fn002 and zero point search mode using parameter Fn003.
- When using the servomotor for a vertical axis, install the safety devices to prevent workpieces to fall off due to occurrence of alarm or overtravel. Set the servomotor so that it will stop in the zero clamp state at occurrence of overtravel.
Failure to observe this caution may cause workpieces to fall off due to overtravel.
- When not using the normal autotuning, set to the correct moment of inertia ratio.
Setting to an incorrect moment of inertia ratio may cause vibration.
- Do not touch the SERVOPACK heatsinks, regenerative resistor, or servomotor while power is ON or soon after the power is turned OFF.
Failure to observe this caution may result in burns due to high temperatures.
- Do not make any extreme adjustments or setting changes of parameters.
Failure to observe this caution may result in injury due to unstable operation.
- When an alarm occurs, remove the cause, reset the alarm after confirming safety, and then resume operation.
Failure to observe this caution may result in injury.
- Do not use the servo brake of the servomotor for ordinary braking.
Failure to observe this caution may result in malfunction.

■ Maintenance and Inspection

CAUTION

- When replacing the SERVOPACK, resume operation only after resetting the potentiometers, pins, and parameters to their original settings.
Failure to observe this caution may result in damage to the product.
- Do not attempt to change wiring while the power is ON.
Failure to observe this caution may result in electric shock or injury.
- Do not disassemble the SERVOPACK.
Failure to observe this caution may result in electric shock or injury.

■ Disposal

 CAUTION
• When disposing of the products, treat them as ordinary industrial waste.

■ General Precautions

The following describes general precautions. Note the following to ensure safe application.

- The drawings presented in this manual are sometimes shown without covers or protective guards. Always replace the cover or protective guard as specified first, and then operate the products in accordance with the manual.
- The drawings presented in this manual are typical examples and may not match the product you received.
- This manual is subject to change due to product improvement, specification modification, and manual improvement. When this manual is revised, the manual code is updated and the new manual is published as a next edition. The edition number appears on the front and back covers.
- If the manual must be ordered due to loss or damage, inform your nearest Yaskawa Electric Engineering representative or one of the offices listed on the back of this manual.
- Yaskawa Electric Engineering will not take responsibility for the results of unauthorized modifications of this product. Yaskawa Electric Engineering shall not be liable for any damages or troubles resulting from unauthorized modification.

CONTENTS

About this manual-	iii
SAFETY INFORMATION-	iv
Notes for Safe Operation-	v

1 Outline

1.1 Outline-	1-2
1.2 Features	1-2
1.2.1 Compatible with SERVOPACK Operating Environments Prior to Σ -Series	1-2
1.2.2 Updated with the Latest Technologies-	1-2
1.2.3 Wide Range of Applicable Servomotors	1-2
1.3 Applicable Servomotors and Encoders	1-3
1.4 SERVOPACK Part Names-	1-4

2 Specifications and Dimensional Drawings

2.1 Ratings and Specifications	2-2
2.2 SERVOPACK Model Designations	2-4
2.3 Re-engineered AC SERVOPACK Selection	2-5
2.4 Dimensional Drawings	2-7
2.4.1 Re-engineered AC SERVOPACKs for CACR-SR02B□ to SR44B□	2-7
2.4.2 Re-engineered AC SERVOPACK Models for CACR-SR60BB, 60BZ, 60BE, and 60BY	2-9

3 Wiring

3.1 Wiring for Re-engineered AC SERVOPACKs CACR-SR□□BF1□□□	3-2
3.1.1 Connection Diagram	3-2
3.1.2 Names and Description of Main Circuit Terminals	3-2
3.1.3 Connector Receptacle Specifications	3-3
3.1.4 CN1 I/O Signal Connector Terminal Layout	3-3
3.1.5 CN2 Optical Encoder (PG) Connector Terminal Layout	3-5
3.2 I/O Signal Connector Terminals	3-6
3.2.1 Re-engineered SERVOPACKs for CACR-SR□□BE (for Multiplexed Incremental Encoder)	3-6
3.2.2 Re-engineered SERVOPACKs for CACR-SR□□BB (for Conventional Incremental Encoder)	3-8
3.2.3 Re-engineered SERVOPACKs for CACR-SR□□BY (for Absolute Encoder)	3-10
3.2.4 Re-engineered SERVOPACKs for CACR-SR□□BZ (for Absolute Encoder)-	3-12

4 Settings and Display

4.1 Setting Switches	4-2
4.1.1 Setting Fixed Switches (User's Modification Prohibited)	4-3
4.1.2 Switches To Be Set According to Application	4-3
4.1.3 Potentiometers VR and RH	4-3
4.1.4 Alarm Reset Button	4-4
4.1.5 LED Display	4-4
4.1.6 Monitoring Pins	4-4
4.1.7 Digital Operator Connector	4-4
4.2 Factory Settings	4-5
4.2.1 Pin Settings	4-5
4.2.2 List of Parameters	4-11

5 Maintenance, Inspection and Alarm/Warning Display

5.1 Status Display	5-2
5.2 Alarm Display Table	5-3
5.3 Warning Displays	5-6
5.4 Inspection and Maintenance	5-7
5.4.1 Servomotor Inspection	5-7
5.4.2 SERVOPACK Inspection	5-7
5.4.3 SERVOPACK's Parts Replacement Schedule	5-7



Outline

- 1.1 Outline -----1-2
- 1.2 Features -----1-2
 - 1.2.1 Compatible with SERVOPACK Operating Environments Prior to Σ -Series ----- 1-2
 - 1.2.2 Updated with the Latest Technologies ----- 1-2
 - 1.2.3 Wide Range of Applicable Servomotors ----- 1-2
- 1.3 Applicable Servomotors and Encoders -----1-3
- 1.4 SERVOPACK Part Names -----1-4

1.1 Outline

The re-engineered AC SERVOPACK model CACR-SR□□BF has been developed to be used for replacement of the conventional SERVOPACK models that had been introduced before Σ -series, using the latest technologies in its circuit configuration.

The re-engineered AC SERVOPACK supports all the types of encoders for AC servodrives: serial encoders and encoders older than serial encoders

The re-engineered AC SERVOPACK provides the operating environment of the following conventional SERVOPACK models.

CACR-SR□□BA

(Speed control/analog control, incremental encoder applicable, base-mounted type)

CACR-SR□□BB

(Speed control/analog control, incremental encoder applicable, base-mounted type)

CACR-SR□□BZ

(Speed control/analog control, absolute encoder applicable, base-mounted type)

CACR-SR□□BE

(Speed control/digital control, incremental encoder applicable, base-mounted type)

CACR-SR□□BY

(Speed control/digital control, absolute encoder applicable, base-mounted type)

1.2 Features

1.2.1 Compatible with SERVOPACK Operating Environments Prior to Σ -Series

Operating Environments:

- External dimensions/installation
(Some models require attachments.)
- Main circuit terminals
- Control connector and signal layout
- Recognizes the encoder type prior to Σ series by the switch setting
(An encoder signal converter is built in.)
- Important adjustments such as speed gain adjustment can be made using the potentiometers VR.
(In the same way as of the conventional models CACR-SR□□BB and BZ)



1.2.2 Updated with the Latest Technologies

- The basic functions and performance are equivalent to those of Σ -III series SERVOPACK
- The parameters of Σ -III series SERVOPACK are applied.
(Parameter setting using a digital operator.)

1.2.3 Wide Range of Applicable Servomotors

The re-engineered AC SERVOPACKs can be combined with various models of servomotors by setting the internal parameters: C series, M series, F series, G series, D series, S series, Σ -series, Σ -II series, and Σ -III series Servomotors.

1.3 Applicable Servomotors and Encoders

The following servomotors besides Σ series, Σ -II series, Σ -III series are applicable.

Applicable Servomotor Models Prior to Σ Series

C Series	M Series	F Series	G Series	D Series	S Series
USACED-03A	USAMED-03	USAFED-02	USAGED-02A	USADED-05E	USASEM-02A
USACED-05A	USAMED-06	USAFED-03	USAGED-03A	USADED-10E	USASEM-03A
USACED-12A	USAMED-09	USAFED-05	USAGED-05A	USADED-15E	USASEM-05A
USACED-20A	USAMED-12	USAFED-09	USAGED-09A	USADED-22E	USASEM-08A
USACED-30A	USAMED-20	USAFED-13	USAGED-13A	USADED-37E	USASEM-15A
USACED-44A	USAMED-30	USAFED-20	USAGED-20A	USAGED-44A	USASEM-30A
USACED-60A	USAMED-44	USAFED-30	USAGED-30A		
	USAMED-60	USAFED-44	USAGED-44A		

Applicable Encoders

Conventional Incremental Encoders	1000 p/r, 1500 p/r, 2500 p/r, 4000 p/r, 5000 p/r, 6000 p/r
Multiplexed Incremental Encoders	2048 p/r, 8192 p/r
Absolute Encoders	1024 p/r, 8192 p/r

1.4 SERVOPACK Part Names



Specifications and Dimensional Drawings

2.1 Ratings and Specifications	2-2
2.2 SERVOPACK Model Designations	2-4
2.3 Re-engineered AC SERVOPACK Selection	2-5
2.4 Dimensional Drawings	2-7
2.4.1 Re-engineered AC SERVOPACKs for CACR-SR02B□ to SR44B□	2-7
2.4.2 Re-engineered AC SERVOPACK Models for CACR-SR60BB, 60BZ, 60BE, and 60BY	2-9

2.1 Ratings and Specifications

Re-engineered SERVOPACK Model CACR-		SR03BF	SR05BF	SR07BF	SR10BF	SR15BF	SR20BF	SR30BF	SR44BF	SR60BF		
Max. Applicable Servomotor Capacity [kW]		0.3	0.5	0.7	1.0	1.5	2.0	3.0	4.4	6.0		
Basic Specifications	Input Power Supply	Main Circuit	Three-phase 200 to 230 VAC +10 to -15 %, 50/60 Hz									
		Control Circuit	Single-phase 200 to 230 VAC +10 to -15 %, 50/60 Hz									
	Continuous Output Current [Arms]		3.0	4.2	5.8	7.6	11.7	19.0	26.0	33.0	45.0	
	Max. Output Current [Arms]		8.5	11.0	13.9	17.0	28.0	42.0	56.6	70.0	80.6	
	Control Method		Three-phase full-wave rectification IGBT-PWM (sine-wave driven)									
	Feedback		Incremental encoder/Absolute encoder (8192 p/r, 2048 p/r, 1024 p/r, 6000 p/r, 5000 p/r, 4000 p/r, 2500 p/r, 1500 p/r, 1000 p/r, etc.)									
	Operating Conditions	Ambient Temperature		0 to 55 °C								
		Storage Temperature		-20 to 85 °C								
		Ambient/Storage Humidity		90 % RH or less (with no condensation)								
		Vibration/Shock Resistance		5 m/s ² / 20 m/s ² (0.5G/2G)								
Configuration		Base-mounted										
Approx. Mass		10 kg										
Performance	Speed Control	Speed Control Range		1:3000								
		Speed Regulation	Load Regulation		0 to 100 % load: 0.01 % max. (at rated speed)							
			Voltage Regulation		0 %							
			Temperature Regulation		25±25 °C: 0.1% max. (at rated speed)							
	Frequency Characteristics		100 Hz									
	Torque Control (Repeatability)		±2 %									
Acceleration Time Setting		0 to 10 s										

(cont'd)

I/O Signals	Speed/Torque References	Rated Reference Voltage	Speed control mode	± 6 VDC (forward rotation with positive reference) at rated speed
			Torque control mode	± 3 VDC (forward rotation with positive reference) at rated torque
		Input Impedance	About 30 k Ω	
		Circuit Time Constant	About 70 μ s	
	Auxiliary Inputs	Rated Reference Voltage	± 2 V to ± 10 VDC (forward rotation with positive reference) at rated speed.	
			Input Impedance	About 30 k Ω
		Circuit Time Constant	About 70 μ s	
	Built-in Reference Power Supply		± 12 VDC ± 5 %, ± 30 mA	
	Position Output (PG pulses)	Form	Line-driver or open-collector (phase A, phase B, phase C)	
		Frequency Dividing Ratio	Any setting ratio	
Sequence Input		Servo ON, P control, forward run prohibited, reverse run prohibited, and alarm reset		
Sequence Output		Servo alarm, servo ready, TG ON, current limit, and alarm code (3-bit output)		
External Current Limits		± 0 V to ± 9 VDC, forward rotation: -3 VDC/rated current, reverse rotation: 3 VDC/rated current		
Built-in Functions	Dynamic Brake (DB)		Operated at main power OFF, servo alarm, servo OFF.	
	Regenerative Processing		Built-in	
	Allowable Load Moment of Inertia		5 times of rotor moment of inertia	
	Overtravel Prevention		Operated at P-OT and N-OT	
	Protection		Overcurrent, regeneration error, overvoltage, input overvoltage, overspeed, insufficient voltage, overload, zero-point pulse error, A/D error, overrun detection, open-phase, and CPU error	
	LED Display		7-segment LED (status and alarm display)	
	Monitor		Speed monitor 1000 r/min ⁻¹ and torque monitor 3V/rated torque	

2.2 SERVOPACK Model Designations

This section explains how to check the SERVOPACK model.

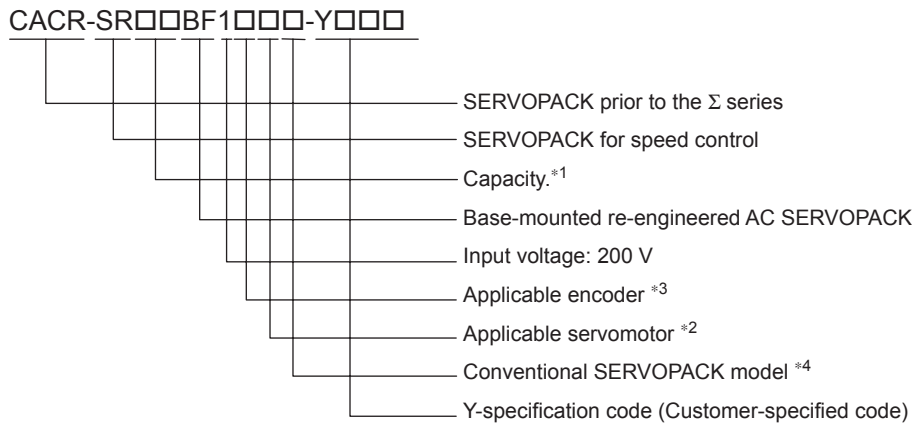

(1) SERVOPACK Capacity and Applicable Servomotors (*1, *2)

Unit: kW

*1 Capacity code \ *2 Applicable servomotor code	M	F	G	S	D	C
02	—	0.15	0.15	0.15	—	—
03	0.3	0.3	0.3	0.31	—	0.25
05	—	0.45	0.45	0.46	0.5	0.5
07	0.6	—	—	—	—	—
10	0.9	0.85	0.85	0.77	—	—
15	1.2	1.3	1.3	1.54	1.0	1.2
20	2.0	1.8	1.8	—	1.5	1.8
30	3.0	2.9	2.9	3.08	2.2	2.9
44	4.4	4.4	4.4	—	3.7	4.4
60	6.0	—	—	—	—	6.0

(2) Encoders (*3)

Type	Pulse	Code
Conventional incremental	1000	F
	1440	H
	1500	E
	2000	K
	2500	C
	4000	D
	5000	B
6000	A	

Type	Pulse	Code
Multiplexed incremental	2048	3
	8192	2
	2500	4

Type	Pulse	Code
Absolute	1024	W
	8192	S

(3) Conventional SERVOPACKs (*4)

Model	Code
CACR-SR□□BB	B
CACR-SR□□BZ	Z
CACR-SR□□BE	E
CACR-SR□□BY	Y
CACR-SR□□BA	A

2.3 Re-engineered AC SERVOPACK Selection

Applicable Servomotors		Conventional SERVOPACK Model SR□□BB and Re-engineered SERVOPACK Model		Conventional SERVOPACK Model SR□□BZ and Re-engineered SERVOPACK Model	
		Conventional Model SR□□BB	Re-engineered Model SR□□BF	Conventional Model SR□□BZ	Re-engineered Model SR□□BF
M	USAMED-03	CACR-SR03BB1□M	CACR-SR03BF1□MB	CACR-SR03BZ1□M	CACR-SR03BF1□MZ
	USAMED-06	CACR-SR07BB1□M	CACR-SR07BF1□MB	CACR-SR07BZ1□M	CACR-SR07BF1□MZ
	USAMED-09	CACR-SR10BB1□M	CACR-SR10BF1□MB	CACR-SR10BZ1□M	CACR-SR10BF1□MZ
	USAMED-12	CACR-SR15BB1□M	CACR-SR15BF1□MB	CACR-SR15BZ1□M	CACR-SR15BF1□MZ
	USAMED-20	CACR-SR20BB1□M	CACR-SR20BF1□MB	CACR-SR20BZ1□M	CACR-SR20BF1□MZ
	USAMED-30	CACR-SR30BB1□M	CACR-SR30BF1□MB	CACR-SR30BZ1□M	CACR-SR30BF1□MZ
	USAMED-44	CACR-SR44BB1□M	CACR-SR44BF1□MB	CACR-SR44BZ1□M	CACR-SR44BF1□MZ
	USAMED-60	CACR-SR60BB1□M	CACR-SR60BF1□MB	CACR-SR60BZ1□M	CACR-SR60BF1□MZ
F	USAFED-02	CACR-SR03BB1□F	CACR-SR03BF1□FB	CACR-SR03BZ1□F	CACR-SR03BF1□FZ
	USAFED-03	CACR-SR03BB1□F	CACR-SR03BF1□FB	CACR-SR03BZ1□F	CACR-SR03BF1□FZ
	USAFED-05	CACR-SR05BB1□F	CACR-SR05BF1□FB	CACR-SR05BZ1□F	CACR-SR05BF1□FZ
	USAFED-09	CACR-SR10BB1□F	CACR-SR10BF1□FB	CACR-SR10BZ1□F	CACR-SR10BF1□FZ
	USAFED-13	CACR-SR15BB1□F	CACR-SR15BF1□FB	CACR-SR15BZ1□F	CACR-SR15BF1□FZ
	USAFED-20	CACR-SR20BB1□F	CACR-SR20BF1□FB	CACR-SR20BZ1□F	CACR-SR20BF1□FZ
	USAFED-30	CACR-SR30BB1□F	CACR-SR30BF1□FB	CACR-SR30BZ1□F	CACR-SR30BF1□FZ
	USAFED-44	CACR-SR44BB1□F	CACR-SR44BF1□FB	CACR-SR44BZ1□F	CACR-SR44BF1□FZ
G	USAGED-02A				
	USAGED-03A				
	USAGED-05A				
	USAGED-09A				
	USAGED-13A				
	USAGED-20A				
	USAGED-30A				
	USAGED-44A				
D	USADED-05E	CACR-SR05BB1□D	CACR-SR05BF1□DB	CACR-SR05BZ1□D	CACR-SR05BF1□DZ
	USADED-10E	CACR-SR10BB1□D	CACR-SR10BF1□DB	CACR-SR10BZ1□D	CACR-SR10BF1□DZ
	USADED-15E	CACR-SR20BB1□D	CACR-SR20BF1□DB	CACR-SR20BZ1□D	CACR-SR20BF1□DZ
	USADED-22E	CACR-SR30BB1□D	CACR-SR30BF1□DB	CACR-SR30BZ1□D	CACR-SR30BF1□DZ
	USADED-37E	CACR-SR44BB1□D	CACR-SR44BF1□DB	CACR-SR44BZ1□D	CACR-SR44BF1□DZ
S	USASEM-02A	CACR-SR02BB1□S	CACR-SR02BF1□SB	CACR-SR02BZ1□S	CACR-SR02BF1□SZ
	USASEM-03A	CACR-SR03BB1□S	CACR-SR03BF1□SB	CACR-SR03BZ1□S	CACR-SR03BF1□SZ
	USASEM-05A	CACR-SR05BB1□S	CACR-SR05BF1□SB	CACR-SR05BZ1□S	CACR-SR05BF1□SZ
	USASEM-08A	CACR-SR10BB1□S	CACR-SR10BF1□SB	CACR-SR10BZ1□S	CACR-SR10BF1□SZ
	USASEM-15A	CACR-SR15BB1□S	CACR-SR15BF1□SB	CACR-SR15BZ1□S	CACR-SR15BF1□SZ
	USASEM-30A	CACR-SR30BB1□S	CACR-SR30BF1□SB	CACR-SR30BZ1□S	CACR-SR30BF1□SZ

Applicable Servomotors		Conventional SERVOPACK Model SR□□BE and Re-engineered SERVOPACK Model		Conventional SERVOPACK Model SR□□BY and Re-engineered SERVOPACK Model	
		Conventional Model	Re-engineered Model SR□□BF	Conventional Model	Re-engineered Model SR□□BF
M	USAMED-03	CACR-SR03BE1□M	CACR-SR03BF1□ME	CACR-SR03BY1□M	CACR-SR03BF1□MY
	USAMED-06	CACR-SR07BE1□M	CACR-SR07BF1□ME	CACR-SR07BY1□M	CACR-SR07BF1□MY
	USAMED-09	CACR-SR10BE1□M	CACR-SR10BF1□ME	CACR-SR10BY1□M	CACR-SR10BF1□MY
	USAMED-12	CACR-SR15BE1□M	CACR-SR15BF1□ME	CACR-SR15BY1□M	CACR-SR15BF1□MY
	USAMED-20	CACR-SR20BE1□M	CACR-SR20BF1□ME	CACR-SR20BY1□M	CACR-SR20BF1□MY
	USAMED-30	CACR-SR30BE1□M	CACR-SR30BF1□ME	CACR-SR30BY1□M	CACR-SR30BF1□MY
	USAMED-44	CACR-SR44BE1□M	CACR-SR44BF1□ME	CACR-SR44BY1□M	CACR-SR44BF1□MY
	USAMED-60	CACR-SR60BE1□M	CACR-SR60BF1□ME	CACR-SR60BY1□M	CACR-SR60BF1□MY
F	USAFED-02	CACR-SR03BE1□F	CACR-SR03BF1□FE	CACR-SR03BY1□F	CACR-SR03BF1□FY
	USAFED-03	CACR-SR03BE1□F	CACR-SR03BF1□FE	CACR-SR03BY1□F	CACR-SR03BF1□FY
	USAFED-05	CACR-SR05BE1□F	CACR-SR05BF1□FE	CACR-SR05BY1□F	CACR-SR05BF1□FY
	USAFED-09	CACR-SR10BE1□F	CACR-SR10BF1□FE	CACR-SR10BY1□F	CACR-SR10BF1□FY
	USAFED-13	CACR-SR15BE1□F	CACR-SR15BF1□FE	CACR-SR15BY1□F	CACR-SR15BF1□FY
	USAFED-20	CACR-SR20BE1□F	CACR-SR20BF1□FE	CACR-SR20BY1□F	CACR-SR20BF1□FY
	USAFED-30	CACR-SR30BE1□F	CACR-SR30BF1□FE	CACR-SR30BY1□F	CACR-SR30BF1□FY
	USAFED-44	CACR-SR44BE1□F	CACR-SR44BF1□FE	CACR-SR44BY1□F	CACR-SR44BF1□FY
G	USAGED-02A	CACR-SR02BE1□G	CACR-SR02BF1□GE	CACR-SR02BY1□G	CACR-SR02BF1□GY
	USAGED-03A	CACR-SR03BE1□G	CACR-SR03BF1□GE	CACR-SR03BY1□G	CACR-SR03BF1□GY
	USAGED-05A	CACR-SR05BE1□G	CACR-SR05BF1□GE	CACR-SR05BY1□G	CACR-SR05BF1□GY
	USAGED-09A	CACR-SR10BE1□G	CACR-SR10BF1□GE	CACR-SR10BY1□G	CACR-SR10BF1□GY
	USAGED-13A	CACR-SR15BE1□G	CACR-SR15BF1□GE	CACR-SR15BY1□G	CACR-SR15BF1□GY
	USAGED-20A	CACR-SR20BE1□G	CACR-SR20BF1□GE	CACR-SR20BY1□G	CACR-SR20BF1□GY
	USAGED-30A	CACR-SR30BE1□G	CACR-SR30BF1□GE	CACR-SR30BY1□G	CACR-SR30BF1□GY
	USAGED-44A	CACR-SR44BE1□G	CACR-SR44BF1□GE	CACR-SR44BY1□G	CACR-SR44BF1□GY
D	USADED-05E	CACR-SR05BE1□D	CACR-SR05BF1□DE	CACR-SR05BY1□D	CACR-SR05BF1□DY
	USADED-10E	CACR-SR10BE1□D	CACR-SR10BF1□DE	CACR-SR10BY1□D	CACR-SR10BF1□DY
	USADED-15E	CACR-SR20BE1□D	CACR-SR20BF1□DE	CACR-SR20BY1□D	CACR-SR20BF1□DY
	USADED-22E	CACR-SR30BE1□D	CACR-SR30BF1□DE	CACR-SR30BY1□D	CACR-SR30BF1□DY
	USADED-37E	CACR-SR44BE1□D	CACR-SR44BF1□DE	CACR-SR44BY1□D	CACR-SR44BF1□DY
S	USASEM-02A	CACR-SR02BE1□S	CACR-SR02BF1□SE	CACR-SR02BY1□S	CACR-SR02BF1□SY
	USASEM-03A	CACR-SR03BE1□S	CACR-SR03BF1□SE	CACR-SR03BY1□S	CACR-SR03BF1□SY
	USASEM-05A	CACR-SR05BE1□S	CACR-SR05BF1□SE	CACR-SR05BY1□S	CACR-SR05BF1□SY
	USASEM-08A	CACR-SR10BE1□S	CACR-SR10BF1□SE	CACR-SR10BY1□S	CACR-SR10BF1□SY
	USASEM-15A	CACR-SR15BE1□S	CACR-SR15BF1□SE	CACR-SR15BY1□S	CACR-SR15BF1□SY
	USASEM-30A	CACR-SR30BE1□S	CACR-SR30BF1□SE	CACR-SR30BY1□S	CACR-SR30BF1□SY

2.4 Dimensional Drawings

2.4.1 Re-engineered AC SERVOPACKs for CACR-SR02B□ to SR44B□

(1) Re-engineered AC SERVOPACK Models for Conventional Models CACR-SR□□BB and -SR□□BZ

Note: □ at the end of the model codes of the re-engineered AC SERVOPACK for CACR-SR□□BB is “B”, and that for CACR-SR□□BZ is “Z” .

For Conventional M-series	For Conventional F-series	For Conventional D-series	For Conventional S-series
Models for which no mounting attachment is required			
CACR-SR03BF1□M□	CACR-SR03BF1□F□	CACR-SR05BF1□D□	CACR-SR02BF1□S□
CACR-SR07BF1□M□	CACR-SR05BF1□F□	CACR-SR10BF1□D□	CACR-SR03BF1□S□
CACR-SR10BF1□M□	CACR-SR10BF1□F□		CACR-SR05BF1□S□
CACR-SR15BF1□M□	CACR-SR15BF1□F□		CACR-SR10BF1□S□
			CACR-SR15BF1□S□
			CACR-SR30BF1□S□
Models for which the mounting attachment F352086-A is required			
CACR-SR20BF1□M□	CACR-SR20BF1□F□	CACR-SR20BF1□D□	CACR-SR30BF1□S□
CACR-SR30BF1□M□	CACR-SR30BF1□F□	CACR-SR30BF1□D□	
CACR-SR44BF1□M□	CACR-SR44BF1□F□	CACR-SR44BF1□D□	

(2) Re-engineered AC SERVOPACK Models for Conventional Models CACR-SR□□BE and -SR□□BY

Note: □ at the end of the model codes of the re-engineered AC SERVOPACK for CACR-SR□□BE is “E”, and that for CACR-SR□□BY is “Y”.

For Conventional M-series	For Conventional F-series	For Conventional D-series	For Conventional S-series	For Conventional G-series
No mounting attachment is required for SERVOPACKs 4.4 kW or less.				
CACR-SR03BF1□M□	CACR-SR03BF1□F□	CACR-SR05BF1□D□	CACR-SR02BF1□S□	CACR-SR02BF1□G□
CACR-SR07BF1□M□	CACR-SR05BF1□F□	CACR-SR10BF1□D□	CACR-SR03BF1□S□	CACR-SR03BF1□G□
CACR-SR10BF1□M□	CACR-SR10BF1□F□	CACR-SR20BF1□D□	CACR-SR05BF1□S□	CACR-SR05BF1□G□
CACR-SR15BF1□M□	CACR-SR15BF1□F□	CACR-SR30BF1□D□	CACR-SR10BF1□S□	CACR-SR10BF1□G□
CACR-SR20BF1□M□	CACR-SR20BF1□F□	CACR-SR44BF1□D□	CACR-SR15BF1□S□	CACR-SR15BF1□G□
CACR-SR30BF1□M□	CACR-SR30BF1□F□		CACR-SR30BF1□S□	CACR-SR20BF1□G□
CACR-SR44BF1□M□	CACR-SR44BF1□F□			CACR-SR30BF1□G□
CACR-SR44BF1□M□	CACR-SR44BF1□F□			CACR-SR44BF1□G□



2.4.2 Re-engineered AC SERVOPACK Models for CACR-SR60BB, 60BZ, 60BE, and 60BY

(1) Re-engineered AC SERVOPACK Models for CACR-SR60BB, 60BZ, 60BE, and 60BY

CACR-SR60BF1□MB
CACR-SR60BF1□MZ
CACR-SR60BF1□ME
CACR-SR60BF1□MY

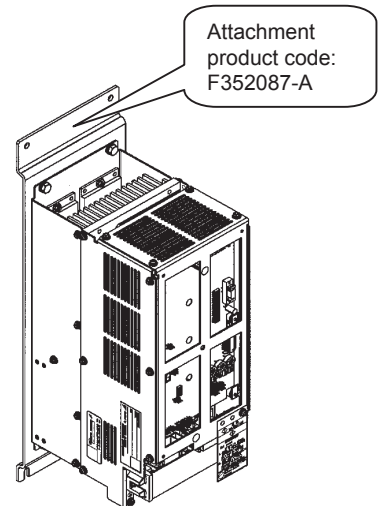
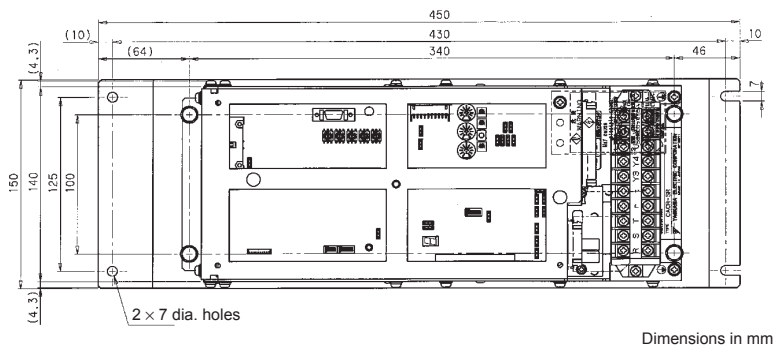

2

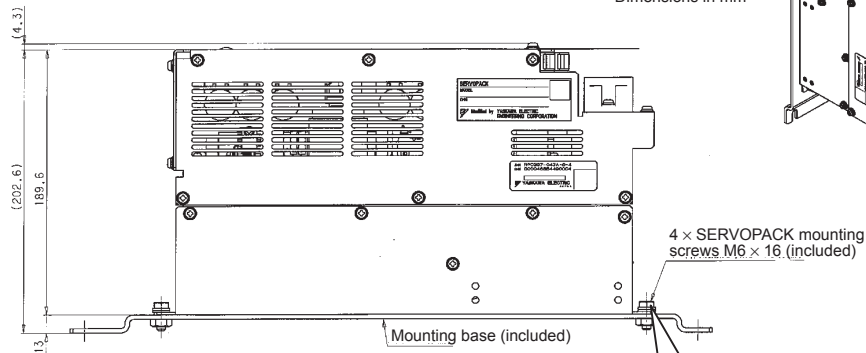

- F352087-A includes:
- Attachment
 - SERVOPACK mounting bolts

Attachment product code: F352087-A

3.1 Wiring for Re-engineered AC SERVOPACKs CACR-SR□□BF1□□□	---	3-2
3.1.1 Connection Diagram	-----	3-2
3.1.2 Names and Description of Main Circuit Terminals	-----	3-2
3.1.3 Connector Receptacle Specifications	-----	3-3
3.1.4 CN1 I/O Signal Connector Terminal Layout	-----	3-3
3.1.5 CN2 Optical Encoder (PG) Connector Terminal Layout	-----	3-5
3.2 I/O Signal Connector Terminals	-----	3-6
3.2.1 Re-engineered SERVOPACKs for CACR-SR□□BE (for Multiplexed Incremental Encoder)	-----	3-6
3.2.2 Re-engineered SERVOPACKs for CACR-SR□□BB (for Conventional Incremental Encoder)	-----	3-8
3.2.3 Re-engineered SERVOPACKs for CACR-SR□□BY (for Absolute Encoder)	-----	3-10
3.2.4 Re-engineered SERVOPACKs for CACR-SR□□BZ (for Absolute Encoder)	-----	3-12

3.1 Wiring for Re-engineered AC SERVOPACKs CACR-SR□□BF1□□□

3.1.1 Connection Diagram

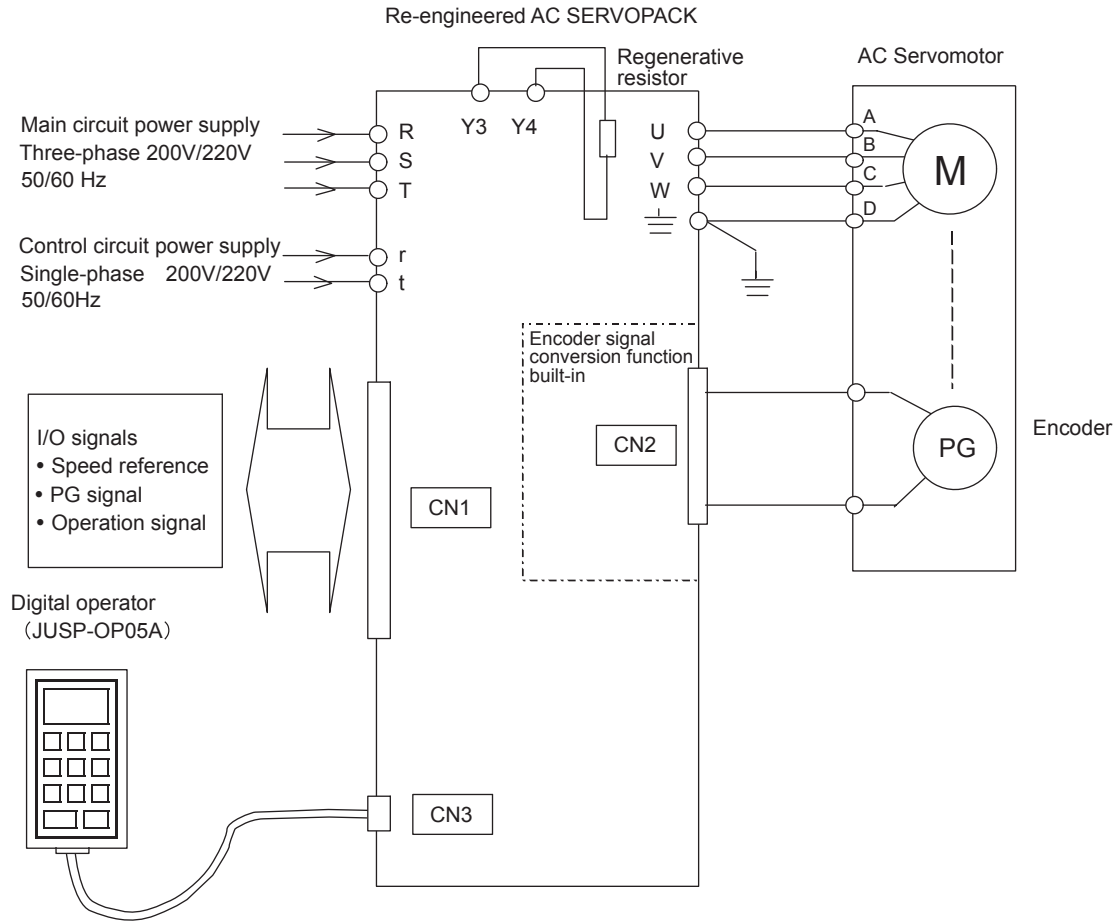

3.1.2 Names and Description of Main Circuit Terminals

Terminal Symbol	Name	Description
(R) (S) (T)	Main circuit input terminals	Three-phase 200 to 230 VAC +10 to -15 %, 50/60 Hz
(U) (V) (W)	Servomotor connection terminals	Connect (U) to the terminal A, (V) to the terminal B, (W) to the terminal C of Servomotor.
(r) (t)	Control circuit input terminals	Single-phase 200 to 230 VAC +10 to -15 %, 50/60 Hz
⊕	Ground terminal	Connect to the power supply ground terminal and the Servomotor D terminal.
(Y3) (Y4)	Regenerative resistor terminals	Regenerative resistor connection terminals (normally not to be connected externally.)

3.1.3 Connector Receptacle Specifications

CN1: For I/O signals

Applicable Receptacle Model

Inside SERVOPACK	Soldered Type	Caulking Type	Case	Manufacturer
MR-50RMA	MR-50F	MRP-50F01	MR-50L	Honda Communication Industries Co., Ltd.

CN2: For connecting the optical encoder (PG)

Applicable Receptacle Model

Inside SERVOPACK	Soldered Type	Caulking Type	Case	Manufacturer
MR-20RMA	MR-20F	MRP-20F01	MR-20L	Honda Communication Industries Co., Ltd.

CN3: For connecting the digital operator

Half-pitch Connector

Plug	Shell	Manufacturer
10114-3000VE	10314-52A0-008	SUMITOMO 3M Limited

3.1.4 CN1 I/O Signal Connector Terminal Layout

Re-engineered AC SERVOPACK Model Pin No.	CACR-SR□□BF1□□□			
	Model No. ended with B (Model for SR□□BB)	Model No. ended with Z (Model for SR□□BZ)	Model No. ended with E (Model for SR□□BE)	Model No. ended with Y (Model for SR□□BY)
1	SG	SG	SG	SG
2	SG	SG	SG	SG
3	SG	SG	SG	SG
4	PHA	SEN	PHA	SEN
5	/V-CMP+	/V-CMP+	/V-CMP+	/V-CMP+
6	/V-CMP-	/V-CMP-	/V-CMP-	/V-CMP-
7	+24V-IN	+24V-IN	+24V-IN	+24V-IN
8	/S-ON	/S-ON	/S-ON	/S-ON
9	TMON	TMON	TMON	TMON
10	VTG	VTG	VTG	VTG
11	SG	SG	SG	SG
12	IN-A	IN-A	V-REF	V-REF
13	SG	SG	SG	SG
14	IN-B	IN-B	T-REF	T-REF
15	SG	SG	SG	SG
16	+12V	+12V	+12V	+12V
17	SG	SG	SG	SG
18	FG	FG	FG	FG
19	PCO	PCO	PCO	PCO
20	/PCO	/PCO	/PCO	/PCO
21	PHC	BAT+	PHC	BAT+
22	/TGON+	/TGON+	/TGON+	/TGON+
23	/TGON-	/TGON-	/TGON-	/TGON-

(cont'd)

Re-engineered AC SERVOPACK Model Pin No.	CACR-SR□□BF1□□			
	Model No. ended with B (Model for SR□□BB)	Model No. ended with Z (Model for SR□□BZ)	Model No. ended with E (Model for SR□□BE)	Model No. ended with Y (Model for SR□□BY)
24	/P-CON	/P-CON	/P-CON	/P-CON
25	OL-	OL-	AL01	empty *2
26	N-OT	N-OT	N-OT	N-OT
27	/S-RDY-	/S-RDY-	/S-RDY-	/S-RDY-
28	/S-RDY+	/S-RDY+	/S-RDY+	/S-RDY+
29	N-CL	N-CL	N-CL	N-CL
30	SG	SG	SG	SG
31	-12V	-12V	-12V	-12V
32	SG	SG	SG	SG
33	PAO	PAO	PAO	PAO
34	/PAO	/PAO	/PAO	/PAO
35	PBO	PBO	PBO	PBO
36	/PBO	/PBO	/PBO	/PBO
37	PHB	BAT-	PHB	BAT-
38	ALM+	ALM+	ALM+	ALM+
39	ALM-	ALM-	ALM-	ALM-
40	OL+	OL+	AL02	empty *2
41	P-OT	P-OT	P-OT	P-OT
42	empty *1	empty *1	AL03	empty
43	empty *1	empty *1	/ALM-RST	/ALM-RST
44	P-CL	P-CL	P-CL	P-CL
45	SG	SG	SG	SG
46	-12V	-12V	-12V	-12V
47	SG	SG	SG	SG
48	+12V	+12V	+12V	+12V
49	SG	SG	SG	SG
50	FG	FG	FG	FG

* 1. The MCB trip signal output function is not provided for SR□□BB and SR□□BZ.

* 2. The PG signal output phase S is not provided for SR□□BY.

3.1.5 CN2 Optical Encoder (PG) Connector Terminal Layout

Pin No.	For Conventional Incremental Encoder	For Multiplexed Type Incremental Encoder	For Absolute Encoder
1	0 V	0 V	0 V
2	0 V	0 V	0 V
3	0 V	0 V	0 V
4	PG5 V	PG5 V	PG5 V
5	PG5 V	PG5 V	PG5 V
6	PG5 V	PG5 V	PG5 V
7	DIR	DIR	DIR
8	PU	–	– *
9	/PU	–	– *
10	PV	Absolute RST	Absolute RST
11	/PV	–	–
12	PW	BAT	BAT
13	/PW	BAT0	BAT0
14	PC	PC	PC
15	/PC	/PC	/PC
16	PA	PA	PA
17	/PA	/PA	/PA
18	PB	PB	PB
19	/PB	/PB	/PB
20	FG	FG	FG

* The phase S rotation amount serial data of 12-bit absolute PG is not processed.

3.2 I/O Signal Connector Terminals

3.2.1 Re-engineered SERVOPACKs for CACR-SR□□BE (for Multiplexed Incremental Encoder)

Example: CACR-SR20BF12FE that have replaced CACR-SR20BE12F

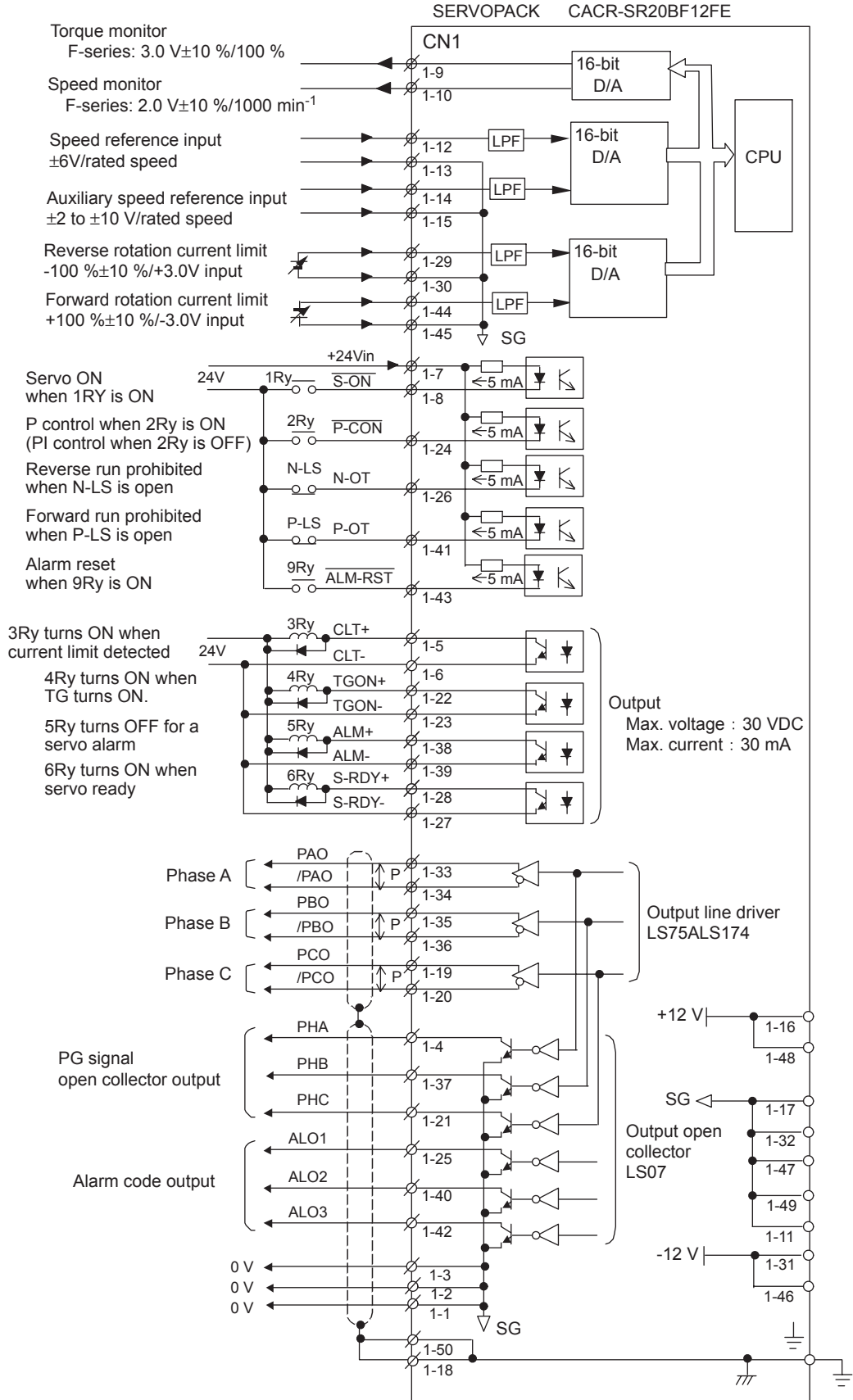

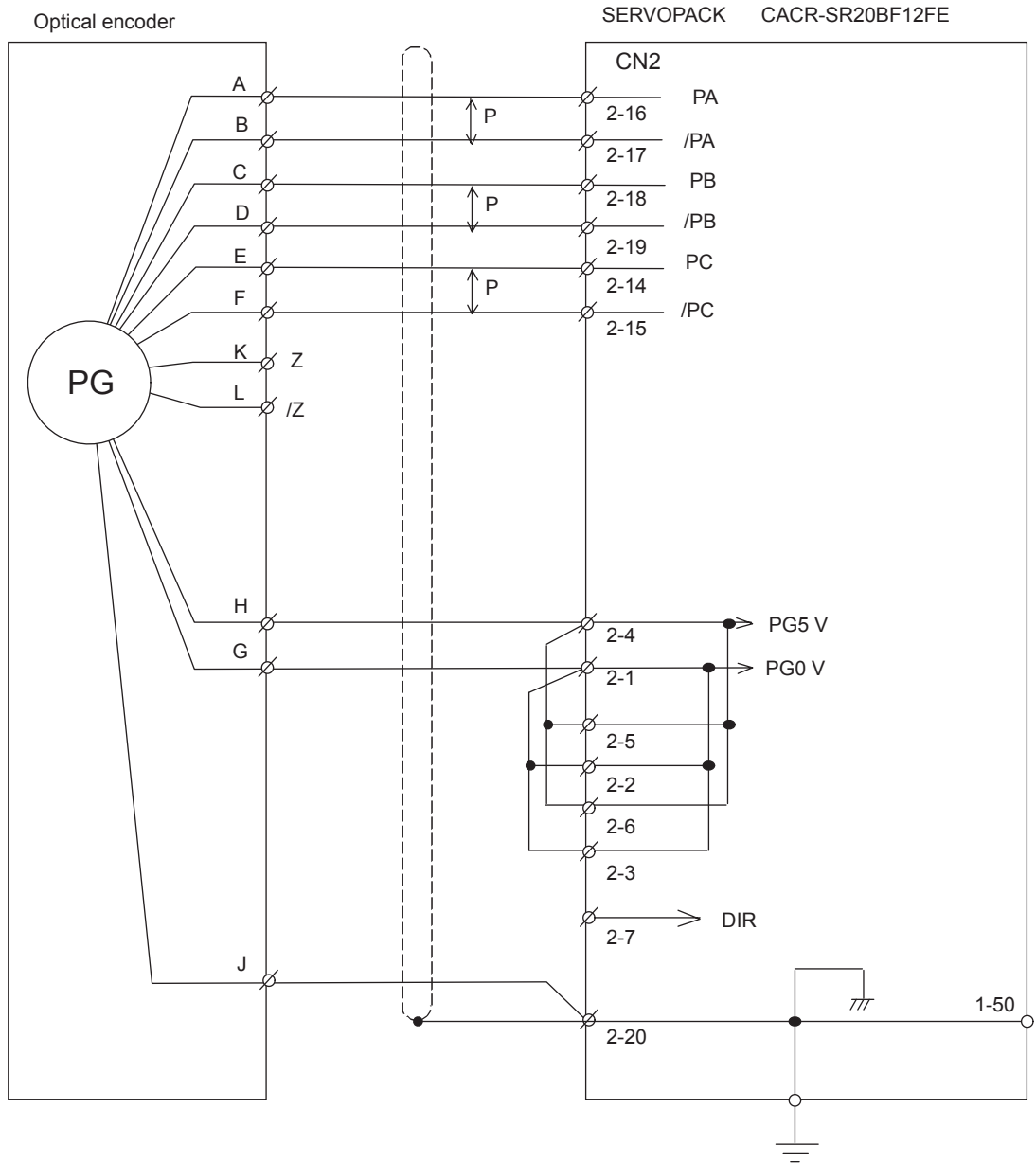

3.2.2 Re-engineered SERVOPACKs for CACR-SR□□BB (for Conventional Incremental Encoder)

Example: CACR-SR20BF1AMB that have replaced CACR-SR20BB1AM

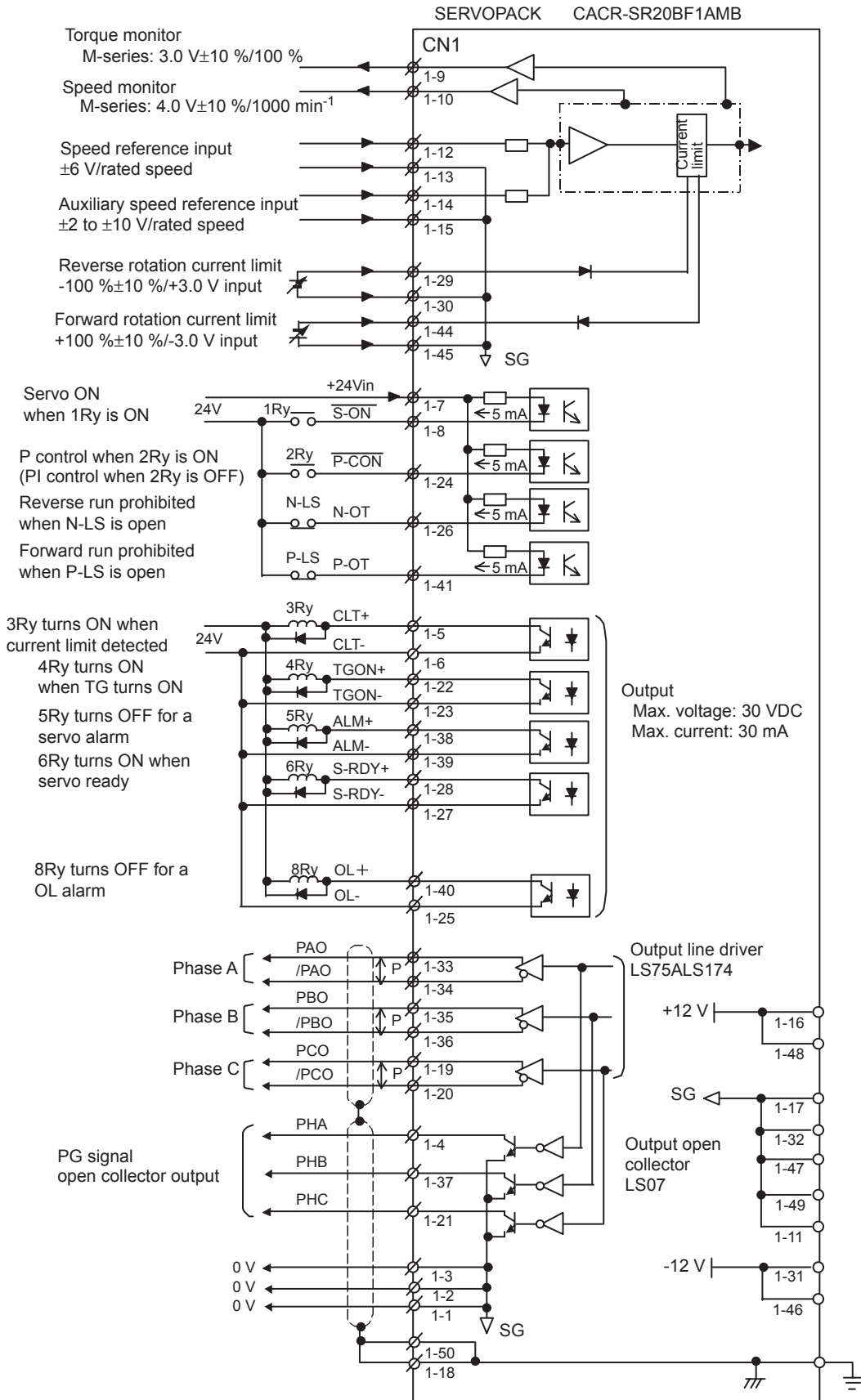

Note: MCB trip (CN1-43 and -42) outputs are not provided.



3

3.2.3 Re-engineered SERVOPACKs for CACR-SR□□BY (for Absolute Encoder)

Example: CACR-SR20BF1SFY that have replaced CACR-SR20BY1SF

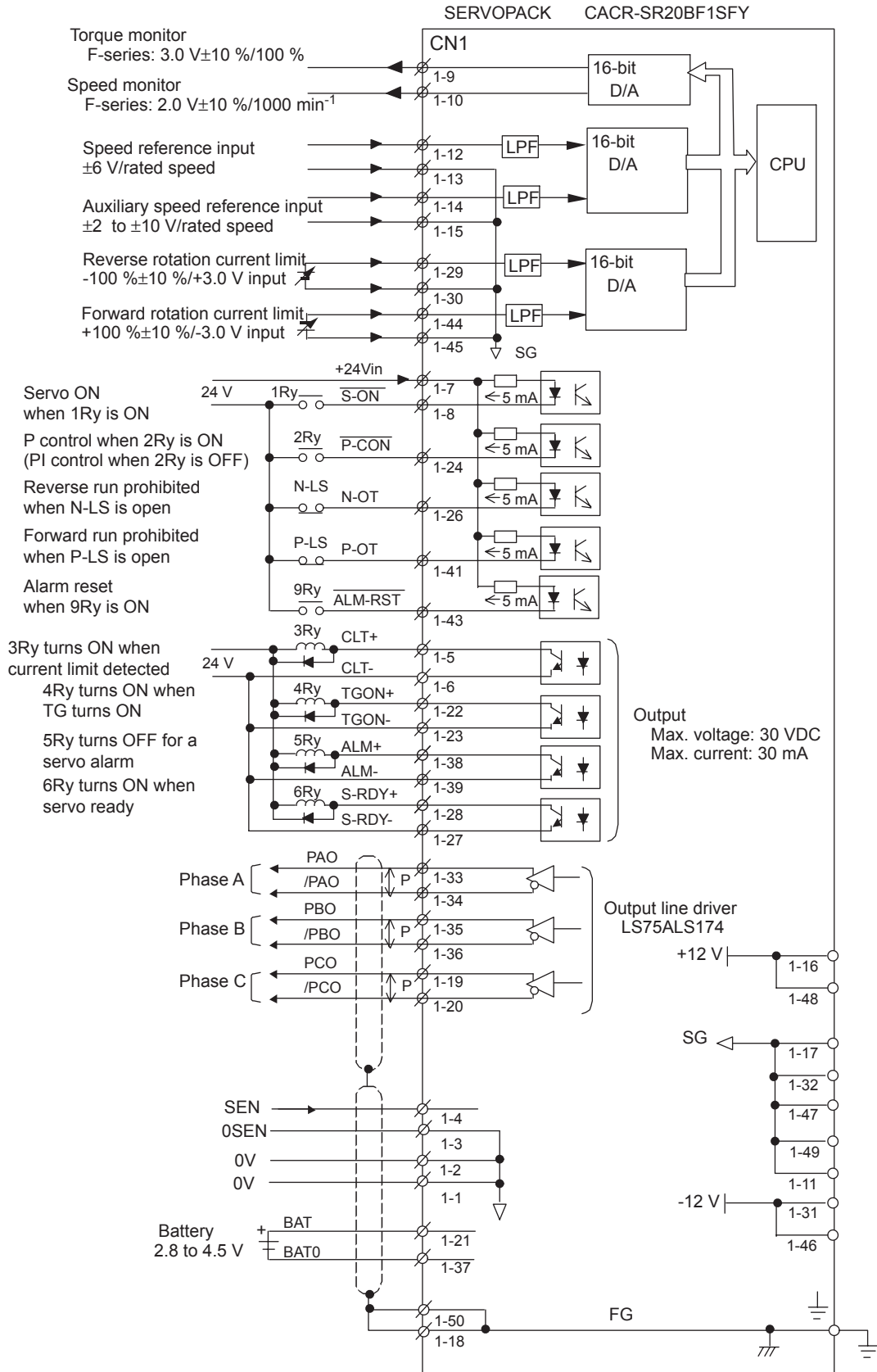

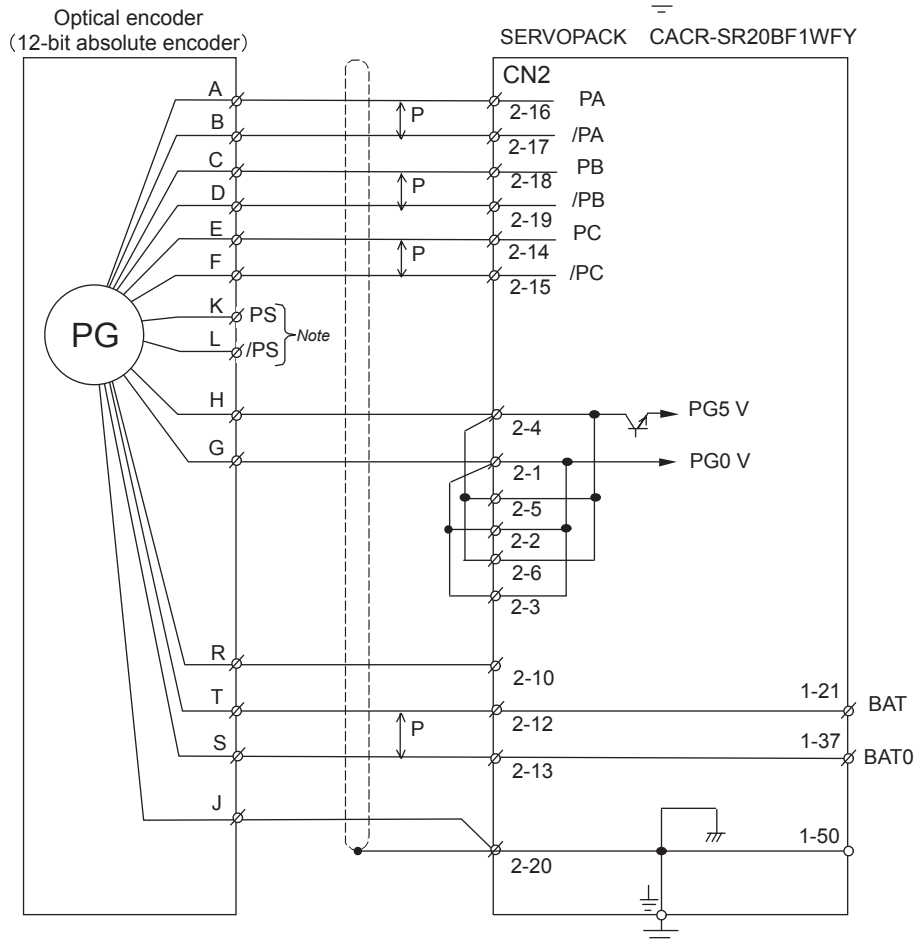
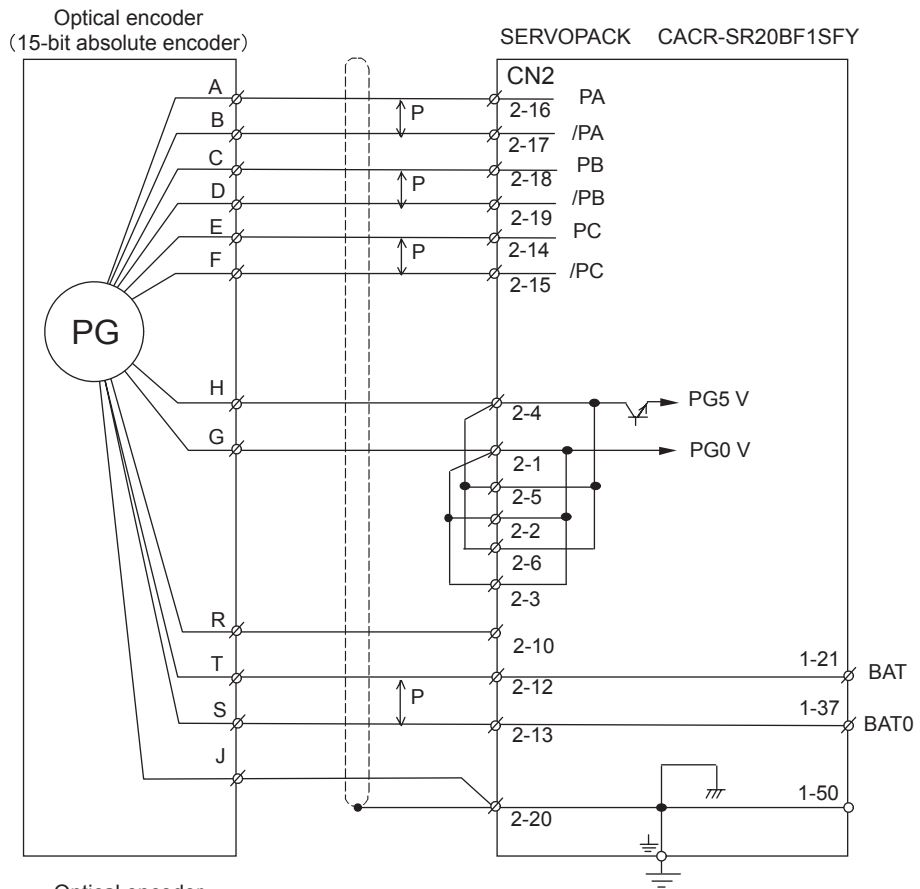

Note: Cut the rotation amount data signal line on the Servomotor encoder cable side.

3.2.4 Re-engineered SERVOPACKs for CACR-SR□□BZ (for Absolute Encoder)

Example: CACR-SR20BF1SMZ that have replaced CACR-SR20BZ1SM



Note: MCB trip (CN1-43 and -42) outputs are not provided.

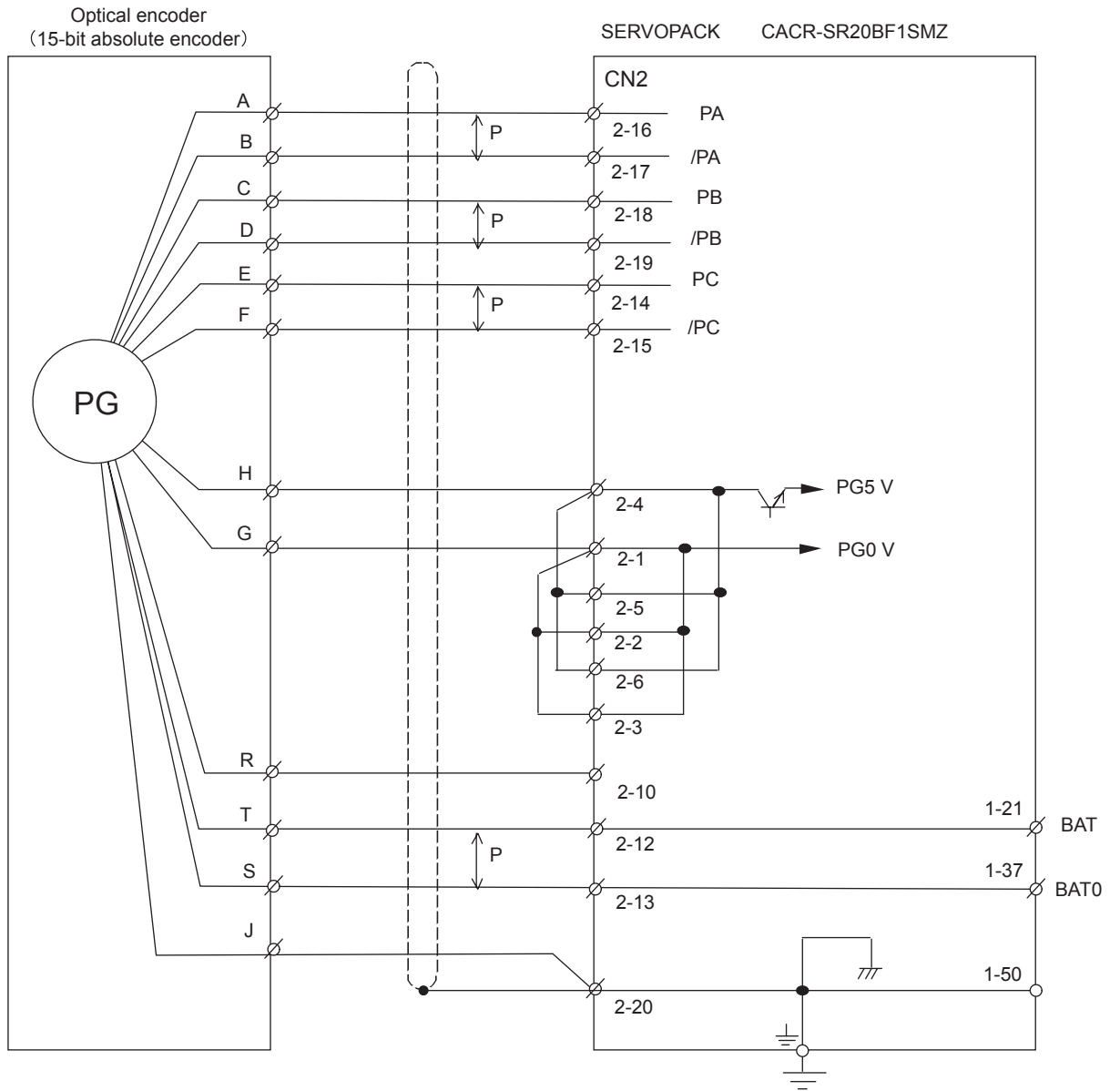

Settings and Display

4.1 Setting Switches	4-2
4.1.1 Setting Fixed Switches (User's Modification Prohibited)	4-3
4.1.2 Switches To Be Set According to Application	4-3
4.1.3 Potentiometers VR and RH	4-3
4.1.4 Alarm Reset Button	4-4
4.1.5 LED Display	4-4
4.1.6 Monitoring Pins	4-4
4.1.7 Digital Operator Connector	4-4
4.2 Factory Settings	4-5
4.2.1 Pin Settings	4-5
4.2.2 List of Parameters	4-11

4.1 Setting Switches

The setting switches are provided on the board inside the re-engineered AC SERVOPACK CACR-SR□□BF to ensure the operating environment of the corresponding conventional model.

There are two types of switches: The switches that have been set and fixed according to the corresponding conventional model before shipment, and the switches that need to be set by users according to the application.

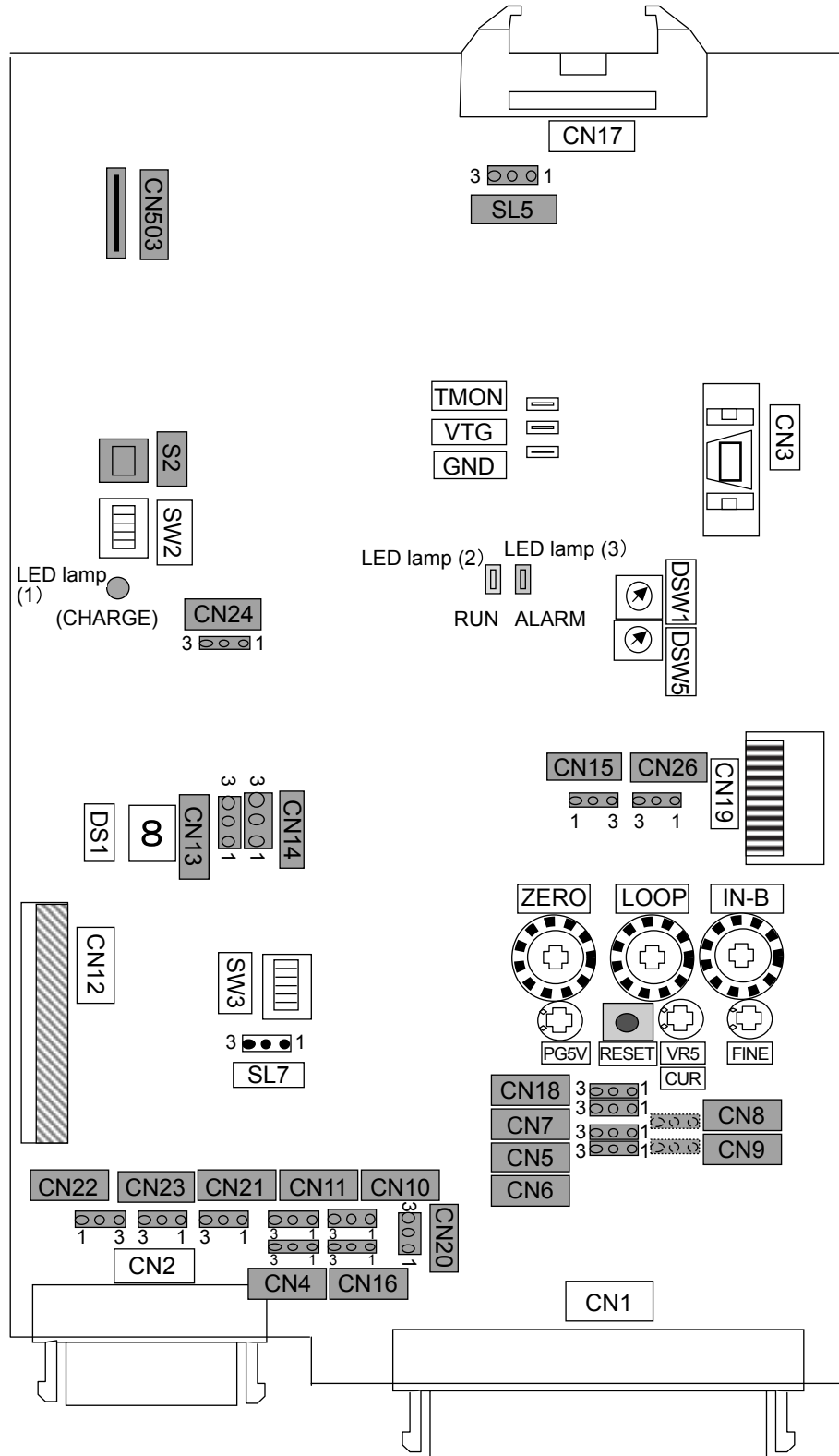

4.1.1 Setting Fixed Switches (User's Modification Prohibited)

The switches listed in the table below have been set to the appropriate values before shipment.

Do not change the settings of these switches. Doing so will cause motor runaway or SERVOPACK failure.

Switch No.	Name	Remarks
CN4	Model depended function selection switch	
CN5	Model depended function selection switch	
CN6	Model depended function selection switch	
CN7	Model depended function selection switch	
CN8	Model depended function selection switch	Not mounted
CN9	Model depended function selection switch	Not mounted
CN10	Model depended function selection switch	
CN11	Model depended function selection switch	
CN13	Model depended function selection switch	
CN14	Model depended function selection switch	
CN15	Model depended function selection switch	
CN16	Model depended function selection switch	
CN18	Model depended function selection switch	
CN20	Model depended function selection switch	
CN21	Model depended function selection switch	
CN22	Model depended function selection switch	
CN23	Model depended function selection switch	
CN24	Model depended function selection switch	
CN26	Model depended function selection switch	
S2	Model depended function selection switch	
SL5	Speed feedback gain switching	
SW3-7	Speed feedback gain switching	
CN503	PC connection connector	Connector for personal computer cable

4.1.2 Switches To Be Set According to Application

The switches listed in the table below need to be set by users according to the application.

Switch No.	Name	Remarks
SL7	Torque filter switching	
SW2	Frequency dividing ratio setting	
SW3	Setting for CACR-SR□□BB/BZ	
DSW1	Encoder setting	
DSW5	Encoder setting	

4.1.3 Potentiometers VR and RH

Set the following potentiometers to the same scale positions as those of your conventional SERVOPACK to obtain the same performance as before replacement.

VR1	IN-B	IN-B input gain
VR6	LOOP	Speed loop gain
VR3	ZERO	Speed amplifier zero adjustment
VR4	FINE	IN-B fine adjustment
VR5	CUR	Starting current adjustment
RH2	PG5V	PG voltage adjustment

4.1.4 Alarm Reset Button

When a SERVOPACK alarm occurs, eliminate the cause and then press the RESET Button to reset the servo alarm.

If the cause has not been eliminated, the alarm will occur again.

RESET	Alarm reset button
-------	--------------------

4.1.5 LED Display

There are four LEDs on the board as follows.

DS1	7-Segment LED	SERVOPACK status and alarm display
LED lamp (1)	Main circuit CHARGE LED	Main circuit with high-voltage
LED lamp (2)	Encoder conversion function	Lit in yellow during normal operation
LED lamp (3)	Encoder conversion alarm	Lit in red at alarm occurrence

4.1.6 Monitoring Pins

The monitoring pins listed in the table below are provided for monitor signals.

The levels are the same as the conventional models.

TMON	For torque monitor	
VTG	For speed monitor	
GND	GND for monitor signal line	

4.1.7 Digital Operator Connector

When using the re-engineered SERVOPACK as the replacement of the conventional model CACR-SR□□BE or CACR-SR□□BY, the connector CN3 is used to connect the digital operator JUSP-OP05A.

CN3	Connector for Σ -III series digital operator	Cable connector
-----	---	-----------------

4.2 Factory Settings

4.2.1 Pin Settings

Switch No.	Setting	Applicable Conventional SERVOPACK Model				Remarks
		SR□□BA SR□□BB	SR□□BE	SR□□BZ	SR□□BY	
CN4	Short-circuited Pins	1-2	2-3	1-2	open	
CN5	Short-circuited Pins	1-2	1-2	2-3	2-3	
CN6	Short-circuited Pins	1-2	1-2	2-3	2-3	
CN7	Short-circuited Pins	1-2	1-2	2-3	2-3	
CN8	Short-circuited Pins	Not mounted				
CN9	Short-circuited Pins					
CN10	Short-circuited Pins	1-2	2-3	1-2	2-3	
CN11	Short-circuited Pins	1-2	2-3	1-2	2-3	
CN13	Short-circuited Pins	1-2	1-2	1-2	1-2	
CN14	Short-circuited Pins	1-2	1-2	1-2	1-2	
CN15	Short-circuited Pins	Set to the defaults at factory depending on re-engineered AC SERVOPACK model				See Table 4.1
CN16	Short-circuited Pins	1-2	2-3	1-2	open	
CN18	Short-circuited Pins	1-2	1-2	1-2	1-2	
CN20	Short-circuited Pins	1-2	2-3	1-2	2-3	
CN21	Short-circuited Pins	1-2	1-2	2-3	2-3	
CN22	Short-circuited Pins	1-2	1-2	2-3	2-3	
CN23	Short-circuited Pins	1-2	1-2	2-3	2-3	
CN24	Short-circuited Pins	1-2	2-3	1-2	1-2	
CN26	Short-circuited Pins	Set to the defaults at factory depending on re-engineered AC SERVOPACK model				See Table 4.1
S2	6-digit ON/OFF	Set to the defaults at factory depending on re-engineered AC SERVOPACK model				See Table 4.1
SL5	Short-circuited Pins	Set to the defaults at factory depending on re-engineered AC SERVOPACK model				See Table 4.3
SL7	Short-circuited Pins	These switches are set to the defaults at factory. Change the setting according to the application.				See Table 4.5
SW2	8-digit ON/OFF					See Table 4.6
SW3	8-digit ON/OFF					See Table 4.4
DSW1	Hexadecimal switching	Set to the defaults at factory depending on encoder type				See Table 4.2
DSW5	Hexadecimal switching					

Table 4.1

Model CACR-	S2-1	S2-2	S2-3	S2-4	S2-5	S2-6	CN15	CN26
SR03BF	OFF	ON	ON	ON	ON	ON	OPEN	OPEN
SR05BF	OFF	ON	ON	ON	ON	OFF	2-3	2-3
SR07BF to 10BF	OFF	ON	ON	ON	OFF	ON	1-2	1-2
SR15BF	OFF	ON	ON	OFF	ON	ON	1-2	1-2
SR20BF	OFF	ON	ON	OFF	OFF	OFF	1-2	1-2
SR30BF	OFF	ON	OFF	ON	ON	OFF	1-2	1-2
SR44BF	OFF	ON	OFF	ON	OFF	ON	1-2	1-2
SR60BF	OFF	ON	OFF	OFF	ON	ON	1-2	1-2

Table 4.2

Servomotor Encoder Specifications			Setting		SW2						
Encoder Type	Model Code	No. of Pulses	DSW1	DSW5	Status						
					1	2	3	4	5	6	7
Conventional incremental	F	1000 P/R	0	0	ON	ON	ON	ON	OFF	OFF	OFF
	H	1440 P/R		1	ON	ON	ON	ON	OFF	ON	OFF
	E	1500 P/R		2	OFF	OFF	ON	ON	OFF	OFF	OFF
	K	2000 P/R		3	OFF	ON	OFF	ON	OFF	OFF	OFF
	C	2500 P/R		4	ON	ON	ON	OFF	OFF	OFF	OFF
	D	4000 P/R		5	ON	OFF	ON	OFF	OFF	OFF	OFF
	B	5000 P/R		6	ON	ON	OFF	OFF	OFF	OFF	OFF
	A	6000 P/R		7	OFF	ON	OFF	OFF	OFF	OFF	OFF
	M	30000 P/R		9	ON	ON	ON	ON	ON	ON	ON
Multiplexed incremental	3	2048 P/R	1	0	ON	OFF	OFF	ON	OFF	OFF	OFF
	2	8192 P/R		1	OFF	OFF	OFF	OFF	OFF	OFF	OFF
Absolute	W	1024 P/R	2	0	OFF	ON	ON	ON	OFF	OFF	OFF
	S	8192 P/R		1	OFF	OFF	OFF	OFF	OFF	OFF	OFF

Set according to the number of encoder pulses.

When the SERVOPACK output dividing ratio is set to 1/1
Pn212 is enabled when SW2-8 is ON.

The settings shown in Tables 4.3, 4.4 and 4.5 are valid on the re-engineered AC SERVOPACKs for CACR-SR□□BB and -SR□□BZ, but invalid for the re-engineered AC SERVOPACK for CACR-SR□□BE and -SR□□BY.

Table 4.3 Motor Rated Speed
(Valid for CACR-SR□□BB and -SR□□BZ)

Servomotor Rated Speed	SL5	SW3-7
1000 r/min ⁻¹	1-2	ON
1500 r/min ⁻¹	2-3	ON
2000 r/min ⁻¹	2-3	OFF
3000 r/min ⁻¹	2-3	ON

Table 4.4 Speed Amplifier Gain (Valid for CACR-SR□□BB and -SR□□BZ)

SW3 Specifications				Factory Settings			
Pin No.	Functions	OFF	ON	M-series F-series	S-series 1 kW and 1.5 kW	S-series 0.5 kW or less, and 3.0 kW	D-series
1	Proportional gain 100 kΩ	Valid	Invalid	ON	OFF	OFF	OFF
2	Proportional gain 220 kΩ	Valid	Invalid	OFF	ON	ON	OFF
3	Imperfect integration 6.6 MΩ	Valid	Invalid	OFF	OFF	OFF	OFF
4	Integration 0.033 uF	Invalid	Valid	ON	OFF	ON	ON
5	Integration 0.033 uF	Invalid	Valid	OFF	OFF	OFF	OFF
6	Integration 0.22 uF	Invalid	Valid	OFF	ON	OFF	OFF
7	For servomotor rated speed			ON	ON	ON	OFF
8	Mode selection switch	Valid	Invalid	OFF	OFF	OFF	OFF

Table 4.5 Torque Filter Switching
(Valid for CACR-SR□□BB and -SR□□BZ)

SL7 Specifications		Factory Setting
Connection	Selected Capacitor	
Short-circuited between 1-2	3200 pF	
Short-circuited between 2-3	2000 pF	Factory setting
Open	1000 pF	

The PG pulse outputs from the SERVOPACK can be set using SW2 pins 1 through 8.

Caution: The maximum number of output pulses that can be set is the number of encoder pulses.

Table 4.6 SW2: No. of Dividing Output Pulses
Settings for Re-engineered AC SERVOPACKs CACR-SR□□BF

1	2	3	4	5	6	7	8	No. of Dividing Output Pulses
OFF	OFF	OFF	OFF	OFF	OFF	OFF	OFF	8192
ON	OFF	OFF	OFF	OFF	OFF	OFF	OFF	8000
OFF	ON	OFF	OFF	OFF	OFF	OFF	OFF	6000
ON	ON	OFF	OFF	OFF	OFF	OFF	OFF	5000
OFF	OFF	ON	OFF	OFF	OFF	OFF	OFF	4096
ON	OFF	ON	OFF	OFF	OFF	OFF	OFF	4000
OFF	ON	ON	OFF	OFF	OFF	OFF	OFF	3000
ON	ON	ON	OFF	OFF	OFF	OFF	OFF	2500
OFF	OFF	OFF	ON	OFF	OFF	OFF	OFF	2400
ON	OFF	OFF	ON	OFF	OFF	OFF	OFF	2048
OFF	ON	OFF	ON	OFF	OFF	OFF	OFF	2000
ON	ON	OFF	ON	OFF	OFF	OFF	OFF	1600
OFF	OFF	ON	ON	OFF	OFF	OFF	OFF	1500
ON	OFF	ON	ON	OFF	OFF	OFF	OFF	1250
OFF	ON	ON	ON	OFF	OFF	OFF	OFF	1024
ON	ON	ON	ON	OFF	OFF	OFF	OFF	1000
OFF	OFF	OFF	OFF	ON	OFF	OFF	OFF	800
ON	OFF	OFF	OFF	ON	OFF	OFF	OFF	750
OFF	ON	OFF	OFF	ON	OFF	OFF	OFF	625
ON	ON	OFF	OFF	ON	OFF	OFF	OFF	600
OFF	OFF	ON	OFF	ON	OFF	OFF	OFF	512
ON	OFF	ON	OFF	ON	OFF	OFF	OFF	500
OFF	ON	ON	OFF	ON	OFF	OFF	OFF	480
ON	ON	ON	OFF	ON	OFF	OFF	OFF	400
OFF	OFF	OFF	ON	ON	OFF	OFF	OFF	375
ON	OFF	OFF	ON	ON	OFF	OFF	OFF	300
OFF	ON	OFF	ON	ON	OFF	OFF	OFF	256
ON	ON	OFF	ON	ON	OFF	OFF	OFF	250
OFF	OFF	ON	ON	ON	OFF	OFF	OFF	240
ON	OFF	ON	ON	ON	OFF	OFF	OFF	200
OFF	ON	ON	ON	ON	OFF	OFF	OFF	160
ON	ON	ON	ON	ON	OFF	OFF	OFF	150
OFF	OFF	OFF	OFF	OFF	ON	OFF	OFF	128
ON	OFF	OFF	OFF	OFF	ON	OFF	OFF	125
OFF	ON	OFF	OFF	OFF	ON	OFF	OFF	120
ON	ON	OFF	OFF	OFF	ON	OFF	OFF	100
OFF	OFF	ON	OFF	OFF	ON	OFF	OFF	80
ON	OFF	ON	OFF	OFF	ON	OFF	OFF	64
OFF	ON	ON	OFF	OFF	ON	OFF	OFF	60

Table 4.6 SW2: No. of Dividing Output Pulses
Settings for Re-engineered AC SERVOPACKs CACR-SR□□BF (cont'd)

1	2	3	4	5	6	7	8	No. of Dividing Output Pulses
ON	ON	ON	OFF	OFF	ON	OFF	OFF	50
OFF	OFF	OFF	ON	OFF	ON	OFF	OFF	40
ON	OFF	OFF	ON	OFF	ON	OFF	OFF	32
OFF	ON	OFF	ON	OFF	ON	OFF	OFF	30
ON	ON	OFF	ON	OFF	ON	OFF	OFF	25
OFF	OFF	ON	ON	OFF	ON	OFF	OFF	20
ON	OFF	ON	ON	OFF	ON	OFF	OFF	16
OFF	ON	ON	ON	OFF	ON	OFF	OFF	1200
ON	ON	ON	ON	OFF	ON	OFF	OFF	1440
OFF	OFF	OFF	OFF	ON	ON	OFF	OFF	360
ON	OFF	OFF	OFF	ON	ON	OFF	OFF	720
OFF	ON	OFF	OFF	ON	ON	OFF	OFF	2880
ON	ON	OFF	OFF	ON	ON	OFF	OFF	6000
OFF	OFF	ON	OFF	ON	ON	OFF	OFF	6000
ON	OFF	ON	OFF	ON	ON	OFF	OFF	6000
OFF	ON	ON	OFF	ON	ON	OFF	OFF	6000
ON	ON	ON	OFF	ON	ON	OFF	OFF	6000
OFF	OFF	OFF	ON	ON	ON	OFF	OFF	6000
ON	OFF	OFF	ON	ON	ON	OFF	OFF	6000
OFF	ON	OFF	ON	ON	ON	OFF	OFF	10000
ON	ON	OFF	ON	ON	ON	OFF	OFF	12500
OFF	OFF	ON	ON	ON	ON	OFF	OFF	15000
ON	OFF	ON	ON	ON	ON	OFF	OFF	20000
OFF	ON	ON	ON	ON	ON	OFF	OFF	25000
ON	ON	ON	ON	ON	ON	OFF	OFF	30000
-	-	-	-	-	-	-	ON	Pn212

Settings for Conventional SERVOPACK SR□□BB with Incremental Encoder for Reference

Check the number of dividing output pulses on the SR□□BB in the following table.

1	2	3	4	5	6	7	Dividing Ratio	(A) 6000	(B) 5000	(D) 4000	(C) 2500	(E) 1500	(F) 1000
○	○	○	○	○	○	○	1/1	6000	5000	4000	2500	1500	1000
	○	○	○	○	○	○	1/2	3000	2500	2000	1250	750	500
○		○	○	○	○	○	1/3	2000	—	—	—	500	—
		○	○	○	○	○	1/4	1500	1250	1000	625	375	250
○	○		○	○	○	○	1/5	1200	1000	800	500	300	200
	○		○	○	○	○	1/6	1000	—	—	—	250	—
			○	○	○	○	1/8	750	625	500	—	—	125
	○	○		○	○	○	1/10	600	500	400	250	150	100
		○		○	○	○	1/12	500	—	—	—	125	—
○				○	○	○	1/15	400	—	—	—	100	—
				○	○	○	1/16	375	—	250	—	—	—
		○	○		○	○	1/20	300	250	200	125	75	50
			○		○	○	1/24	250	—	—	—	—	—
○	○	○			○	○	1/25	240	200	160	100	60	40
	○				○	○	1/30	200	—	—	—	50	—
			○	○		○	1/40	150	125	100	—	—	25
				○		○	1/48	125	—	—	—	—	—
	○	○	○			○	1/50	120	100	80	50	30	20
		○				○	1/60	100	—	—	—	25	—
	○	○	○	○	○		2/2	6000	5000	4000	2500	1500	1000
○		○	○	○	○		2/3	4000	—	—	—	1000	—
		○	○	○	○		2/4	3000	2500	2000	1250	750	500
○	○		○	○	○		2/5	2400	2000	1600	1000	600	400
	○		○	○	○		2/6	2000	—	—	—	500	—
			○	○	○		2/8	1500	1250	1000	625	—	250
	○	○		○	○		2/10	1200	1000	800	500	300	200
		○		○	○		2/12	1000	—	—	—	250	—
○				○	○		2/15	800	—	—	—	200	—
				○	○		2/16	750	—	500	—	—	125
		○	○		○		2/20	600	500	400	250	150	100
			○		○		2/24	500	—	—	—	125	—
○	○	○			○		2/25	480	400	320	200	120	80
	○				○		2/30	400	—	—	—	100	—
			○	○			2/40	300	250	200	125	75	50
				○			2/48	250	—	—	—	—	—
	○	○	○				2/50	240	200	160	100	60	40
		○					2/60	200	—	—	—	50	—

Note: The pin SW2-8 is reserved. The pins marked with ○ are short-circuited.

Settings for Conventional SERVOPACK SR□□BZ with Absolute Encoder for Reference

Check the number of dividing output pulses on the SR□□BZ in the following table.

1	2	3	4	5	6	(s) 8192	1	2	3	4	5	6	(s) 8192
○	○	○	○	○	○	6000	○	○	○	○	○		60
	○	○	○	○	○	5000		○	○	○	○		50
○		○	○	○	○	4000	○		○	○	○		40
		○	○	○	○	3000			○	○	○		30
○	○		○	○	○	2500	○	○		○	○		25
	○		○	○	○	2400		○		○	○		20
○			○	○	○	2000	○			○	○		8192
			○	○	○	1600				○	○		4096
○	○	○		○	○	1500	○	○	○		○		2048
	○	○		○	○	1250		○	○		○		1024
○		○		○	○	1200	○		○		○		512
		○		○	○	1000			○		○		256
○	○			○	○	800	○	○			○		128
	○			○	○	750		○			○		64
○				○	○	625	○				○		3600
				○	○	600					○		2160
○	○	○	○		○	500	○	○	○	○			1800
	○	○	○		○	480		○	○	○			1440
○		○	○		○	400	○		○	○			1080
		○	○		○	375			○	○			720
○	○		○		○	320	○	○		○			360
	○		○		○	300		○		○			180
○			○		○	250	○			○			90
			○		○	240				○			45
○	○	○			○	200	○	○	○				(15)
	○	○			○	160		○	○				(12)
○		○			○	150	○		○				(9)
		○			○	125			○				(8)
○	○				○	120	○	○					(5)
	○				○	100		○					(4)
○					○	80	○						(3)
					○	75							(2)

Note: The pins SW2-7 and -8 are reserved. The pins marked with ○ are short-circuited.

4.2.2 List of Parameters

Parameter No.	Name	Setting Range	Unit	Factory Setting	Setting Validation	Conventional Model SR□□BE/BY Constant No.
Pn000	Function Selection Basic Switch 0		–	0	After restart	–
Pn001	Function Selection Application Switch 1		–	0	After restart	–
Pn002	Function Selection Application Switch 2		–	0	After restart	–
Pn100	Speed Loop Gain	1.0 to 2000.0 Hz	0.1 Hz	40.0 Hz	Immediately	Cn-04
Pn101	Speed Loop Integral Time Constant	0.15 to 512.00 ms	0.01 ms	20.00 ms	Immediately	Cn-05
Pn102	Position Loop Gain	1.0 to 2000.0/s	0.1/s	40.0/s	Immediately	–
Pn107	Bias	0 to 450 min ⁻¹	1 min ⁻¹	0 min ⁻¹	Immediately	–
Pn108	Bias Addition Width	0 to 250 reference units	Reference unit	7 reference units	Immediately	–
Pn109	Feed Forward Gain	0 to 100 %	1%	0 %	Immediately	–
Pn10B	Gain-related Application Switch	–	–	0	Immediately	–
Pn10C	Mode Switch (torque reference)	0 to 800 %	1%	200%	Immediately	Cn-0C
Pn10D	Mode Switch (speed reference)	0 to 10000 min ⁻¹	1 min ⁻¹	0 min ⁻¹	Immediately	Cn-0D
Pn10E	Mode Switch (acceleration)	0 to 30000 r/min/s	1 r/min/s	0 r/min/s	Immediately	Cn-0E
Pn10F	Mode Switch (position error pulse)	0 to 10000 reference units	Reference unit	0 reference unit	Immediately	–
Pn200	Position Control Reference Form Selection Switch		–	0	After restart	–
Pn209	Position Reference Acceleration/Deceleration Bias	0 to 65535 reference units/s	1 reference unit/s	0	Immediately	–
Pn20E	Electronic Gear Ratio (Numerator)	1 to 1073741824 (2 ³⁰)	–	4	After restart	–
Pn210	Electronic Gear Ratio (Denominator)	1 to 1073741824 (2 ³⁰)	–	1	After restart	–
Pn212	PG Dividing Pulse (pulse unit) Enabled when SW2-8 is ON	16 to 1073741824 (2 ³⁰) P/Rev	1 P/Rev	2048 P/Rev	After restart	Cn-0A
Pn300	Speed Reference Input Gain	1.50 to 10.00 V/ rated speed	0.01 V/ rated speed	6.00 V/ rated speed	Immediately	–
Pn304	JOG Speed	0 to 10000 min ⁻¹	1 min ⁻¹	500 min ⁻¹	Immediately	Cn-10
Pn305	Soft Start Acceleration Time	0 to 10000 ms	1 ms	0 ms	Immediately	Cn-07
Pn306	Soft Start Deceleration Time	0 to 10000 ms	1 ms	0 ms	Immediately	Cn-23
Pn30A	Auxiliary Speed Reference Input Gain	1.50 to 10.00 V/ rated speed	0.01 V/ rated speed	10.00 V/ rated speed	Immediately	Cn-03
Pn400	Torque Reference Input Gain	1.0 to 10.0 V/ rated torque	0.1 V/ rated torque	3.0 V/ rated torque	Immediately	Cn-13
Pn401	1st Step 1st Torque Reference Filter Time Constant	0.00 to 655.35 ms	0.01 ms	1.00 ms	Immediately	Cn-17
Pn402	Forward Torque Limit	0 to 800 %	1 %	800 %	Immediately	Cn-08
Pn403	Reverse Torque Limit	0 to 800 %	1 %	800 %	Immediately	Cn-09
Pn406	Emergency Stop Torque	0 to 800 %	1 %	800 %	Immediately	Cn-06
Pn407	Speed Limit during Torque Control	0 to 10000 min ⁻¹	1 min ⁻¹	10000 min ⁻¹	Immediately	Cn-14
Pn408	Torque Related Function Switch	–	–	0	After restart	–
Pn415	External Current Limit Input Gain	1.0 to 10.0V/ rated torque	0.1V/ rated torque	3.0V/ rated torque	Immediately	–

Note: The parameters in shaded area have been set according to the SERVOPACK model before shipment. Contact Yaskawa service division when changing the settings of these parameters.

(cont'd)

Parameter No.	Name	Setting Range	Unit	Factory Setting	Setting Validation	Conventional Model SR□□BE/BY Constant No.
Pn501	Zero Clamp Level	0 to 10000 min ⁻¹	1 min ⁻¹	10 min ⁻¹	Immediately	Cn-0F
Pn502	Zero Speed Level	1 to 10000 min ⁻¹	1 min ⁻¹	20 min ⁻¹	Immediately	Cn-0B
Pn503	Speed Coincidence Signal Output Width	0 to 100 min ⁻¹	1 min ⁻¹	10 min ⁻¹	Immediately	–
Pn506	Brake Reference - Servo OFF Delay Time	(0 to 50) × 10 ms	10 ms	0 ms	Immediately	Cn-12
Pn507	Brake Reference Output Speed Level	0 to 10000 min ⁻¹	1 min ⁻¹	100 min ⁻¹	Immediately	Cn-15
Pn508	Waiting Time for Brake Signal When Motor Running	(10 to 100) × 10 ms	10 ms	500 ms	Immediately	Cn-16
Pn509	Instantaneous Power Cut Hold Time	20 to 1000 ms	1 ms	20 ms	Immediately	–
Pn50A	Input Signal Selection 1	–	–	2100	After restart	–
Pn50B	Input Signal Selection 2	–	–	6543	After restart	–
Pn50C	Input Signal Selection 3	–	–	8888	After restart	–
Pn50D	Input Signal Selection 4	–	–	8888	After restart	–
Pn50E	Output Signal Selection 1	–	–	3211	After restart	–
Pn50F	Output Signal Selection 2	–	–	0	After restart	–
Pn510	Output Signal Selection 3	–	–	0	After restart	–
Pn512	Output Signal Reversal Setting	–	–	0	After restart	–
Pn520	Excessive Position Error Alarm Level	1 to 1073741824 (2 ³⁰) reference units	1 reference unit	262144 reference units	Immediately	–
Pn522	Positioning Completed Width	0 to 1073741824 (2 ³⁰) reference units	1 reference unit	7 reference units	Immediately	–

Note: The parameters in shaded area have been set according to the SERVOPACK model before shipment.
Contact Yaskawa service division when changing the settings of these parameters.

Maintenance, Inspection and Alarm/Warning Display

5.1 Status Display	-----	5-2
5.2 Alarm Display Table	-----	5-3
5.3 Warning Displays	-----	5-6
5.4 Inspection and Maintenance	-----	5-7
5.4.1 Servomotor Inspection	-----	5-7
5.4.2 SERVOPACK Inspection	-----	5-7
5.4.3 SERVOPACK's Parts Replacement Schedule	-----	5-7

5.1 Status Display

The 7-segment LED (DS1) on the re-engineered AC SERVOPACK indicates the SERVOPACK status.

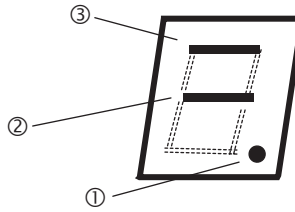

- When no alarm occurs, the bits are lit as shown in the table below.

Bit Data Indication

Item	Bit Data	Indication
①	Control Power ON	Lights when the control power to the SERVOPACK turns ON.
②	Baseblock	Lights when baseblocked (the servo turns OFF.) Goes out when the servo turns ON.
③	Rotation Detection (TGON)	Lights when the motor speed is higher than the value specified in Pn502. (Factory setting: 20 min ⁻¹)

- When an alarm occurs, the corresponding alarm code is displayed and blinks digit by digit for 250 msec.

5.2 Alarm Display Table

The re-engineered SERVOPACK model CACR-SR□□BF has the same alarm function as that of Σ -III series SERVOPACK.

If an alarm occurs, the servomotor can be stopped by doing either of the following operations.

- DB stop: Stops the servomotor immediately using the dynamic brake.
- Zero-speed stop: Stops the servomotor by setting the speed reference to “0.”

Table 5.1 Alarm Display Table

Alarm Display	Alarm Name	Meaning	Servomotor Stop Method	Alarm Reset	Alarm Code Output			Servo Alarm (ALM) Output
					ALO1	ALO2	ALO3	
A.020	Parameter Checksum Error	The data of the parameter in the SERVOPACK is incorrect.	DB stop	N/A	H	H	H	H
A.021	Parameter Format Error	The data of the parameter in the SERVOPACK is incorrect.	DB stop	N/A				
A.022	System Checksum Error	The data of the parameter in the SERVOPACK is incorrect.	DB stop	N/A				
A.023	Parameter Password Error	The data of the parameter in the SERVOPACK is incorrect.	DB stop	N/A				
A.030	Main Circuit Detector Error	Detection data for power circuit is incorrect.	DB stop	Available				
A.031	Main Circuit (Power Pack) Alarm	The switch S2 is set incorrectly	DB stop	N/A				
A.040	Parameter Setting Error	The parameter setting is outside the allowable setting range.	DB stop	N/A				
A.041	Dividing Pulse Output Setting Error	The PG dividing pulse setting (Pn212) is outside the allowable setting range or not satisfies the setting conditions. This alarm may occur when using-SR□□BF1□□E or -SR□□BF1□□Y.	DB stop	N/A				
A.042	Parameter Combination Error	Combination of some parameters exceeds the setting range.	DB stop	N/A				
A.050	Combination Error	SERVOPACK and servomotor capacities do not match each other.	DB stop	Available				
A.051	Unsupported Product Alarm	The serial converter unit unsupported was connected.	DB stop	N/A				
A.0b0	Servo ON reference Invalid Alarm	The Host controller reference was sent to turn the Servo ON after the Servo ON function was used with the Digital Operator or SigmaWin+.	DB stop	Available				
A.100	Overcurrent or Heat Sink Overheated	An overcurrent flowed through the IGBT. Heat sink of SERVOPACK was overheated.	DB stop	N/A	L	H	H	H
A.300	Regeneration Error Detected	Regenerative circuit or regenerative resistor is faulty.	DB stop	Available	L	L	H	H
A.320	Regenerative Overload	Regenerative energy exceeds regenerative resistor capacity.	Zero speed stop	Available				
A.330	Main Circuit Power Supply Wiring Error	The power supply to the main circuit does not match the parameter Pn001 setting.	DB stop	Available				
A.400	Overvoltage	Main circuit DC voltage is excessively high.	DB stop	Available	H	H	L	H
A.410	Undervoltage	Main circuit DC voltage is excessively low.	Zero speed stop	Available				

Table 5.1 Alarm Display Table (cont'd)

Alarm Display	Alarm Name	Meaning	Servomotor Stop Method	Alarm Reset	Alarm Code Output			Servo Alarm (ALM) Output
					ALO1	ALO2	ALO3	
A.510	Overspeed	The servomotor speed is excessively high.	DB stop	Available				
A.511	Dividing Pulse Output Overspeed	The motor speed upper limit of the set PG dividing pulse (Pn212) is exceeded.	DB stop	Available	L	H	L	H
A.520	Vibration Alarm	Vibration at the motor speed was detected.	DB stop	Available				
A.521	Autotuning Alarm	The moment of inertia ratio calculation error occurred.	DB stop	Available				
A.710	Overload: High Load	The motor was operating for several seconds to several tens of seconds under a torque largely exceeding ratings.	Zero speed stop	Available				
A.720	Overload: Low Load	The motor was operating continuously under a torque largely exceeding ratings.	DB stop	Available				
A.730	Dynamic Brake Overload	When the dynamic brake was applied, rotational energy exceeded the capacity of dynamic brake resistor.	DB stop	Available	L	L	L	H
A.740	Overload of Surge Current Limit Resistor	The main circuit power was frequently turned ON and OFF.	DB stop	Available				
A.7A0	Heat Sink Overheated	The heat sink of SERVOPACK overheated.	Zero speed stop	Available				
A.810	Encoder Backup Error	All the power supplies for the absolute encoder have failed and position data was cleared.	DB stop	N/A				
A.820	Encoder Checksum Error	The checksum results of encoder memory is incorrect.	DB stop	N/A				
A.830	Absolute Encoder Battery Error	Battery voltage for the absolute encoder has dropped.	DB stop	Available				
A.840	Encoder Data Error	Data in the encoder is incorrect.	DB stop	N/A				
A.850	Encoder Overspeed	The encoder was rotating at high speed when the power was turned ON.	DB stop	N/A				
A.860	Encoder Overheated	The internal temperature of encoder is too high.	DB stop	N/A	H	H	H	H
A.b10	Reference Speed Input Read Error	The A/D converter for reference speed input is faulty.	Zero speed stop	Available				
A.b11	Speed Reference A/D Data Error	A/D conversion data of speed reference is incorrect.	Zero speed stop	Available				
A.b20	Reference Torque Input Read Error	The A/D converter for reference torque input is faulty.	Zero speed stop	Available				
A.b31	Current Detection Error 1	Phase-U current sensor is faulty.	DB stop	N/A				
A.b32	Current Detection Error 2	Phase-V current sensor is faulty.	DB stop	N/A				
A.b33	Current Detection Error 3	Phase-W current sensor is faulty.	DB stop	N/A				

Table 5.1 Alarm Display Table (cont'd)

Alarm Display	Alarm Name	Meaning	Servomotor Stop Method	Alarm Reset	Alarm Code Output			Servo Alarm (ALM) Output
					ALO1	ALO2	ALO3	
A.bF0	System Alarm 0 (Internal program processing error)	“Internal program error 0” of SERVOPACK occurred.	DB stop	N/A	H	H	H	H
A.bF1	System Alarm 1 (Internal program error)	“Internal program error 1” of SERVOPACK occurred.	DB stop	N/A				
A.bF2	System Alarm 2 (Current control processing program error)	“Internal program error 2” of SERVOPACK occurred.	DB stop	N/A				
A.bF3	System Alarm 3 (Encoder interface processing error)	“Internal program error 3” of SERVOPACK occurred.	DB stop	N/A				
A.bF4	System Alarm 4 (CPU watchdog timer error)	“Internal program error 4” of SERVOPACK occurred.	DB stop	N/A				
A.C10	Servo Overrun Detected	The servomotor ran out of control.	DB stop	Available	L	H	L	H
A.C80	Absolute Encoder Clear Error and Multi-turn Limit Setting Error	The multi-turn for the absolute encoder was not properly cleared or set.	DB stop	N/A				
A.C90	Encoder Communications Error	Communications between SERVOPACK and encoder is not possible.	DB stop	N/A				
A.C91	Encoder Communications Position Data Error	An encoder position data calculation error occurred.	DB stop	N/A				
A.C92	Encoder Communications Timer Error	An error occurs in the communications timer between the encoder and the SERVOPACK.	DB stop	N/A				
A.CA0	Encoder Parameter Error	Encoder parameters are faulty.	DB stop	N/A				
A.Cb0	Encoder Echoback Error	Contents of communications with encoder is incorrect.	DB stop	N/A				
A.CC0	Multi-turn Limit Disagreement	Different multi-turn limits have been set in the encoder and SERVOPACK.	DB stop	N/A				
A.d00	Position Error Pulse Overflow	Position error pulse exceeded parameter (Pn520).	DB stop	Available	L	L	H	H
A.d01	Position Error Pulse Overflow Alarm at Servo ON	When the servo turns ON, the position error pulses exceeded the parameter setting (Pn526).	DB stop	Available				
A.d02	Position Error Pulse Overflow Alarm by Speed Limit at Servo ON	If the servo turns ON with position error pulses accumulated, the speed is limited by Pn529. In this state, the reference pulse was input without resetting the speed limit, and the position error pulses exceeds the value set for the parameter Pn520.	Zero speed stop	Available				
A.F10	Power Line Open Phase	One phase is not connected in the main power supply.	Zero speed stop	Available	H	L	H	H
A.F20	AC Overvoltage Alarm	A voltage higher than 200 VAC is supplied	DB stop	N/A				
CPF00	Digital Operator Transmission Error	Digital operator (JUSP-OP05A) fails to communicate with SERVOPACK (e.g., CPU error).	–	N/A	Not decided			
CPF01			–	N/A				
A.–	Not an error	Normal operation status	–	–	H	H	H	L

5.3 Warning Displays

The relation between warning displays and warning code outputs are shown in table 5.2.

Table 5.2 Warning Displays and Outputs

Warning Display	Warning Name	Meaning	Warning Code Output		
			ALO1	ALO2	ALO3
A.910	Overload	This warning occurs before the overload alarms (A.710 or A.720) occur. If the warning is ignored and operation continues, an overload alarm may occur.	L	H	H
A.911	Vibration	Abnormal vibration at the motor speed was detected. The detection level is the same as A.520. Set whether to output an alarm or warning by "Vibration Detection Switch" of Pn310.	L	H	H
A.920	Regenerative Overload	This warning occurs before the regenerative overload alarm (A.320) occurs. If the warning is ignored and operation continues, a regenerative overload alarm may occur.	H	L	H
A.930	Absolute Encoder Battery Voltage Lowered	This warning occurs when the absolute encoder battery voltage is lowered.	L	L	H
A.941	Change of Parameters Requires Setting Validation	The change of the parameters can be validated only after turning the power ON from OFF.	L	H	H

5.4 Inspection and Maintenance

5.4.1 Servomotor Inspection

The AC servomotors are brushless. Simple daily inspection is sufficient. The inspection and maintenance frequencies in the table are only guidelines. Increase or decrease the frequency to suit the operating conditions and environment.

IMPORTANT

During inspection and maintenance, do not disassemble the servomotor.

Item	Frequency	Procedure	Comments
Vibration and Noise	Daily	Touch and listen.	Levels higher than normal?
Exterior	According to degree of contamination	Clean with cloth or compressed air.	–
Insulation Resistance Measurement	At least once a year	Disconnect SERVOPACK and test insulation resistance at 500 V. Must exceed 10 MΩ.*	Contact the Yaskawa service division if the insulation resistance is below 10 MΩ.
Replacing Oil Seal	At least once every 5000 hours	Remove the servomotor and replace the oil seal.	Applies only to servomotors with oil seals.
Overhaul	At least once every 20000 hours or 5 years	Contact the Yaskawa service division.	Do not disassemble and clean the servomotor by yourself.

* Measure across the servomotor's FG and the phase-U, phase-V, or phase-W power line.

5.4.2 SERVOPACK Inspection

Item	Frequency	Procedure	Comments
Exterior and Boards	At least once a year	Check for dust, dirt, and oil on the surfaces.	Clean with compressed air.
		Check for discoloration, damage, and disconnected wires on the surfaces.	Contact the Yaskawa service division.
Loose Screws		Check for loose terminal block and connector screws.	Tighten any loose screws.

5.4.3 SERVOPACK's Parts Replacement Schedule

The following electric or electronic parts are subject to mechanical wear or deterioration over time. To avoid failure, replace these parts at the frequency indicated.

The parameters of any SERVOPACKs overhauled by Yaskawa service division are reset to the factory settings before shipping. Be sure to confirm that the parameters are properly set before starting operation.

Part	Standard Replacement Period	Recommendations	Operating Conditions
Cooling Fan	4 to 5 years	Replace with a new SERVOPACK.	<ul style="list-style-type: none"> • Ambient Temperature: Annual average of 30°C • Load Factor: 80% max. • Operation Rate: 20 hours/day max.
Smoothing Capacitor	7 to 8 years	Replace with a new SERVOPACK. (Depending on results of investigation.)	
Relays	–	Replace with a new SERVOPACK. (Depending on results of investigation.)	
Fuses	10 years	Replace with a new SERVOPACK.	
Aluminum Electrolytic Capacitor on Circuit Board	5 years	Replace with a new SERVOPACK. (Depending on results of investigation.)	

Applications and Inquiries

YASKAWA ENGINEERING Global Office



<Japan>

YASKAWA ENGINEERING CORPORATION

480 Kamifujisawa, Iruma, Saitama 358-0013, Japan
Phone +81-4-2966-1862 Fax +81-4-2966-2766
<http://www.yaskawa-eng.co.jp>

<North & South America>

YASKAWA ELECTRIC AMERICA, INC.

2121 Norman Drive South, Waukegan, IL 60085, USA
Phone +1-874-887-7000
Phone +1-800-YASKAWA(1-800-927-5292)
from U.S.A. and Canada
Fax +1-874-887-7440
<http://www.yaskawa.com>

Yaskawa Eléctrico do Brasil Ltda.

Av. Fagundes Filho, 620-Saúde
São Paulo, SP 04304-000, Brasil
Phone +55-11-5071-2552 Fax +55-11-5581-8795
<http://www.yaskawa.com.br>

<Europe>

YASKAWA ENGINEERING EUROPE GmbH

Am kronberger Hang 2, 65824 Schwalbach, Germany
Phone +49-6196-569-520 Fax +49-6196-888-598
<http://www.yaskawa.de>

<Asia>

YASKAWA ENGINEERING ASIA-PACIFIC PTE. LTD.

151 Lorong Chuan, #04-01B,
New Tech Park, Singapore 556741, SINGAPORE
Phone +65-6282-1601 Fax +65-6382-3668
<http://www.yaskawa.com.sg>

YASKAWA ELECTRIC (SHANGHAI) CO., LTD.

No.18 Aona Road, Waigaoqiao Free
Trade Zone, Pudong New Area
Shanghai 200131, P.R. China
Phone +86-21-5385-2200 Fax +86-21-5385-3299

YASKAWA ENGINEERING KOREA CORPORATION

KFPA Bldg. #1201, 35-4, Youido-Dong
Yeongdungpo-Ku, Seoul 150-010, Korea
Phone +82-2-3775-0337 Fax +82-2-784-8495
<http://www.yaskawa.co.kr>

YASKAWA ELECTRIC TAIWAN CORPORATION

9F, 16, Nanking E.Rd., Sec. 3, Taipei, Taiwan
Phone +886-2-2502-5003 Fax +886-2-2505-1280

YASKAWA ELECTRIC (THAILAND) CO., LTD.

252/101 20th floor, Muang Thai-phatra Office Tower
2, Rachadaphisek Road, Huaykwang,
Bangkok 10320, THAILAND
Phone +662-693-2200 Fax +662-693-2204



YASKAWA

YASKAWA ELECTRIC ENGINEERING CORPORATION

In the event that the end user of this product is to be the military and said product is to be employed in any weapons systems or the manufacture thereof, the export will fall under the relevant regulations as stipulated in the Foreign Exchange and Foreign Trade Regulations. Therefore, be sure to follow all procedures and submit all relevant documentation according to any and all rules, regulations and laws that may apply.

Specifications are subject to change without notice for ongoing product modifications and improvements.

© 2004 YASKAWA ELECTRIC CORPORATION. All rights reserved.

MANUAL NO. KG22E

Printed in Japan October 2004 04-10