

Varispeed-626MTIII Drives

AC ADJUSTABLE SPEED DRIVES FOR MACHINE TOOL SPINDLES

3.7 TO 30 kW (5 TO 40 HP), 30-MINUTE OPERATION RATING

2.2 TO 22 kW (3 TO 60 HP), CONTINUOUS OPERATION RATING

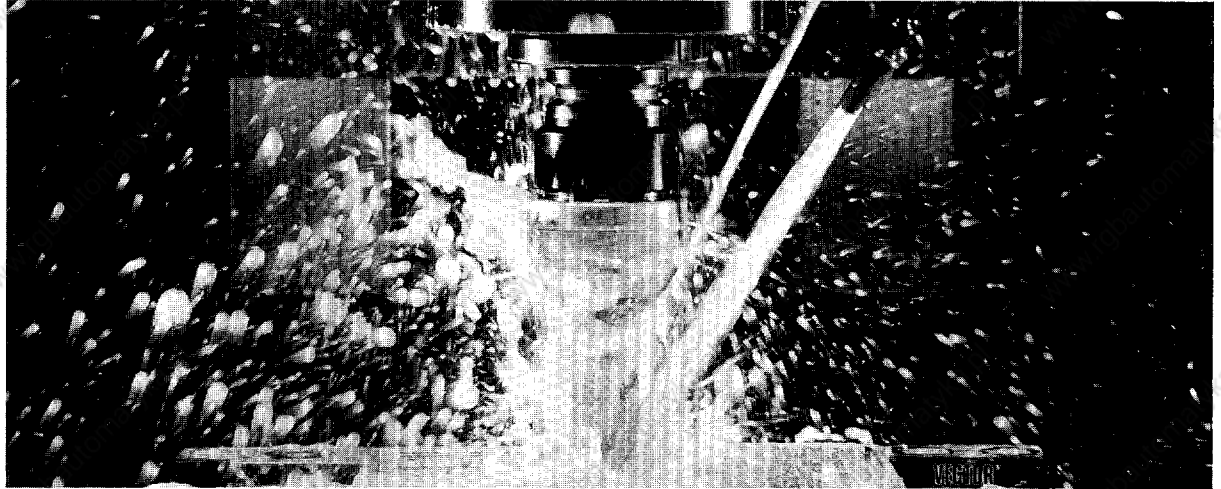

YASKAWA

Varispeed-626MTⅢ Drives (VS-626MTⅢ) are highly reliable adjustable speed AC spindle motor drives for NC machine tools. VS-626MTⅢ drives combine a compact, high speed AC spindle drive motor with a digital vector-controlled, high performance transistor inverter (controller).

The VS-626MTⅢ drives achieve high speed operation and heavy duty machining even while operating under adverse environmental conditions. The VS-626MTⅢ is an ideal spindle drive for machining centers, lathes, milling machines, etc.

The features of the VS-626MTⅢ are as follows:

- **8000 r/min max and constant power range (1 : 5.3) (for 7.5kW or below)**
- **Constant power (1 : 12) with winding selection**
- **Enhanced performance through digital vector control**
- **Compact and lightweight**
- **Low vibration/low noise operation**
- **Improved machining due to unique motor cooling system**
- **Reliable functions for improved maintainability**

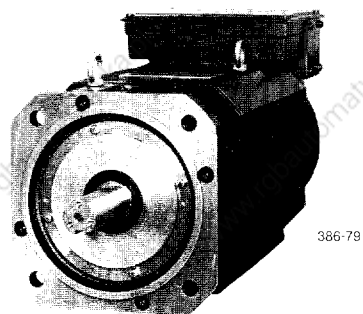

AC Spindle Motor
Flange-mounted Model UAASKA-08CA1

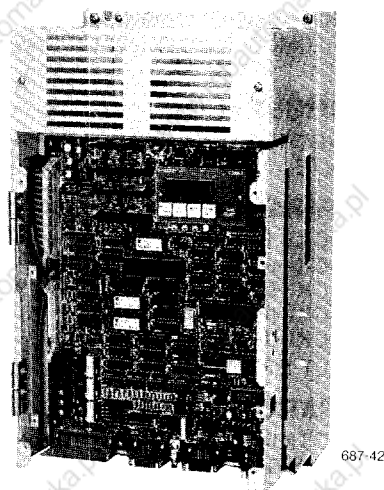

VS-626MTⅢ Controller
Model CIMR-MTⅢ-7.5K

CONTENTS

1. RATINGS AND SPECIFICATIONS	1
1.1 STANDARD SPECIFICATIONS	1
1.2 STATUS MONITORING FUNCTIONS	3
1.3 PROTECTION FUNCTIONS	4
2. CHARACTERISTICS	5
2.1 OUTPUT POWER–SPEED CHARACTERISTICS	5
2.2 TORQUE–SPEED CHARACTERISTICS	6
2.3 MOTOR MECHANICAL CHARACTERISTICS	7
3. BLOCK DIAGRAM	8
4. WIRING	9
4.1 INTERCONNECTIONS	9
4.2 CONNECTOR SIGNAL LIST	10
4.3 LEAD SPECIFICATIONS	12
4.4 WIRING INSTRUCTIONS	13
5. CONTROL SIGNAL	16
5.1 SEQUENCE INPUT SIGNAL	16
5.2 SPEED REFERENCE	20
5.3 SEQUENCE OUTPUT SIGNAL	23
5.4 OPTICAL ENCODER (PG) PULSE OUTPUT CIRCUIT	26
5.5 ANALOG OUTPUT SIGNAL	27
6. DIMENSIONS AND INSTALLATION	28
6.1 AC SPINDLE MOTOR DIMENSIONS	28
6.2 VS-626MT ^{III} CONTROLLER DIMENSIONS	29
6.3 INSTALLATION	30
7. CONFIGURATION	32
7.1 CONSTRUCTION OF VS-626MT ^{III} CONTROLLER	32
7.2 PRINTED CIRCUIT BOARD LAYOUT	33
8. PREPARATION FOR OPERATION	34
8.1 CHECKS BEFORE TEST RUN	34
8.2 CHECKING POWER UNIT AND PRINTED CIRCUIT BOARDS	34
8.3 CHECKING POTENTIOMETER SETTING	34
8.4 CHECKING POWER SUPPLY VOLTAGE	34
8.5 CHECKING SPEED COMMAND INPUT SELECTION	35
8.6 FAULT DETECTION IN ISOLATION AMPLIFIER IN BASE DRIVE	36
9. OPERATION ON THE SETTING PANEL	37
9.1 FUNCTIONS OF THE SETTING PANEL	37
9.2 LED DISPLAY AND OPERATION KEYS	37
9.3 KEY OPERATION AND LED DISPLAY	38
9.4 ALARM DISPLAY	40
9.5 CONTROL SIGNALS	41
10. TEST RUN	42
10.1 CHECKING AFTER POWER ON	42
10.2 STATE DISPLAY	43
10.3 CONTROL CONSTANTS	43
10.4 OPERATION	45
11. SETTING AND ADJUSTMENT	46
11.1 SETTING	46
11.2 ADJUSTMENT	48
12. VS-626MT^{III} CHECK TERMINALS AND THEIR SIGNALS	51
13. MAINTENANCE	52
13.1 DAILY INSPECTION ITEMS	52
13.2 PERIODIC CLEANING	52
13.3 PERIODIC INSPECTION	53
13.4 CHECKING SEMICONDUCTOR ELEMENTS FOR MAIN CIRCUIT	54
13.5 REPLACEMENT OF PRINTED CIRCUIT BOARDS	56
14. TROUBLESHOOTING	60
15. SPARE PARTS	66

CONTENTS (Cont'd)

Features of Winding Selection	67
16. SPECIFICATIONS	68
17. CHARACTERISTICS	69
17.1 OUTPUT POWER, TORQUE VS MOTOR SPEED	69
17.2 MOTOR MECHANICAL SPECIFICATIONS	71
18. MOTOR DIMENSIONS AND MOUNTING CONDITIONS in mm	72
18.1 MOTOR DIMENSIONS mm	72
18.2 AC SPINDLE MOTOR MOUNTING CONDITIONS	73
19. WIRING	74
19.1 INTERCONNECTIONS	74
19.2 CONNECTORS	75
20. CONTROL SIGNALS	76
21. OPERATION	78
21.1 MOTOR CHARACTERISTICS	78
21.2 WINDING SELECTION OPERATION	79
21.3 WINDING SELECTION PROCEDURES	79
21.4 NOTES	82
22. MAGNETIC CONTACTOR FOR WINDING SELECTION	83
22.1 RATING AND SPECIFICATIONS	83
22.2 DIMENSIONS	83
22.3 OPERATION	83
23. TROUBLESHOOTING	84
Magnetic Sensor Type Spindle Orientation	85
24. SPECIFICATIONS	85
24.1 SPINDLE ORIENTATION SPECIFICATIONS	85
24.2 DETECTOR SPECIFICATIONS	86
25. SYSTEM CONFIGURATION	87
26. OUTLINE OF OPERATION	88
26.1 ORIENTATION CONTROL	88
26.2 ORIENTATION OPERATION	89
27. WIRING SPECIFICATIONS	90
27.1 INTERCONNECTIONS BETWEEN DEVICES	90
27.2 DESCRIPTION OF CONTROL SIGNALS	91
28. DIMENSIONS AND INSTALLATION	93
28.1 DIMENSIONS	93
28.2 INSTALLING MAGNETO AND MAGNETIC SENSOR	95
28.3 PRECAUTIONS IN MOUNTING	96
29. COMPONENTS OF ORIENTATION CARD	97
30. ADJUSTMENT	98
30.1 FUNCTION OF POTENTIOMETERS AND SHUNT CONNECTOR	98
30.2 ADJUSTING PROCEDURES	100
30.3 ADJUSTMENT OF POTENTIOMETERS	103
31. LED DISPLAY	106
32. CHECK TERMINALS AND THEIR SIGNALS	107
33. REPLACEMENT OF ORIENTATION BOARD	107
34. TROUBLESHOOTING FOR SPINDLE ORIENTATION SYSTEM	108
Encoder Type Spindle Orientation	109
35. SPECIFICATIONS	109
35.1 SPINDLE ORIENTATION SPECIFICATIONS	109
35.2 ENCODER SPECIFICATIONS	110

CONTENTS (Cont'd)

36. CONFIGURATION	111
37. ORIENTATION OUTLINE	112
37.1 ORIENTATION CONTROL OUTLINE	112
37.2 ORIENTATION OPERATION	113
38. WIRING DIAGRAM	116
38.1 INTERCONNECTION DIAGRAM	116
38.2 CONNECTOR PIN ARRANGMENT	117
38.3 PRECAUTIONS ON WIRING	118
39. DESCRIPTION OF CONTROL SIGNALS	119
40. DIMENSIONS AND INSTALLATION	123
40.1 ORIENTATION CARD (JPAC-C346)	123
40.2 ENCODER (PC-1024LH□K-68)	123
41. ADJUSTMENT	124
41.1 FUNCTIONS OF DIP SWITCHES AND SELECT CONNECTORS	124
41.2 SETTING OF CONTROL CONSTANTS MONITORING CONTROL SIGNALS	125
41.3 ADJUSTING PROCEDURE	129
41.4 SETTING EACH PART	131
42. TROUBLESHOOTING	134
APPENDIX A HOW TO CALCULATE ACCELERATION AND DECELERATION TIME	136
APPENDIX B HOW TO CALCULATE GD²	138

INDEX

Subject	Section No.	Page
A Absolute Positioning	37. 2. 2	113
AC Spindle Motor	10. 1. 1	42
AC SPINDLE MOTOR DIMENSIONS	6. 1	28
AC SPINDLE MOTOR MOUNTING CONDITIONS	18. 2	73
Adjustable Potentiometers	30. 1. 1	98
ADJUSTING PROCEDURE	41. 3	129
ADJUSTING PROCEDURES	30. 2	100
ADJUSTMENT	11. 2	48
ADJUSTMENT	30	98
ADJUSTMENT	41	124
Adjustment of Load Meter	11. 2. 3	49
Adjustment of Loop Gain of Speed Control System	11. 2. 4	50
Adjustment of Motor Speed	11. 2. 1	48
ADJUSTMENT OF POTENTIOMETERS	30. 3	103
Adjustment of Speedometer	11. 2. 2	49
ALARM DISPLAY	9. 4	40
Allowable Radial Load	2. 3. 1	7
ANALOG OUTPUT SIGNAL	5. 5	27
Auto Winding Change Method	21. 3. 2	81
B BCD Command Resolution	41. 4. 3	132
BIAS Adjustment	30. 3. 2	103
BLOCK DIAGRAM	3	8
C CHARACTERISTICS	2	5
CHARACTERISTICS	17	69
CHECK TERMINALS AND THEIR SIGNALS	32	107
CHECKING AFTER POWER ON	10. 1	42
CHECKING POTENTIOMETER SETTING	8. 3	34
CHECKING POWER SUPPLY VOLTAGE	8. 4	34
CHECKING POWER UNIT AND PRINTED CIRCUIT BOARDS	8. 2	34
CHECKING SEMICONDUCTOR ELEMENTS FOR MAIN CIRCUIT	13. 4	54
CHECKING SPEED COMMAND INPUT SELECTION	8. 5	35
CHECKS BEFORE TEST RUN	8. 1	34
COMPONENTS OF ORIENTATION CARD	29	97
CONFIGURATION	7	32
CONFIGURATION	36	111
CONNECTORS	19. 2	75
CONNECTOR PIN ARRANGEMENT	38. 2	117
CONNECTOR SIGNAL LIST	4. 2	10
CONSTRUCTION OF VS-626MTIII CONTROLLER	7. 1	32
CONTROL CONSTANTS	10. 3	43
CONTROL SIGNAL	5	16
Control Signal Display	9. 3. 2	38
CONTROL SIGNALS	9. 5	41
CONTROL SIGNALS	20	76
Control Signals and Control Constants	41. 2. 2	127
D DAILY INSPECTION ITEMS	13. 1	52
DESCRIPTION OF CONTROL SIGNALS	27. 2	91
DESCRIPTION OF CONTROL SIGNALS	39	119
DETECTOR SPECIFICATIONS	24. 2	86
DIMENSIONS	22. 2	83

INDEX (Cont'd)

Subject	Section No.	Page
D DIMENSIONS	28. 1	93
DIMENSIONS AND INSTALLATION	6	28
DIMENSIONS AND INSTALLATION	28	93
DIMENSIONS AND INSTALLATION	40	123
Diode Module	13. 4. 3	56
Display and Setting of Control Constants	9. 3. 4	38
Display of Alarm	41. 2. 3	128
E Encoder Type Spindle Orientation		109
ENCODER	40. 2	123
ENCODER SPECIFICATIONS	35. 2	110
External Torque Limit Level Setting	11. 1. 2	46
F FAULT DETECTION IN ISOLATION AMPLIFIER IN BASE DRIVE	8. 6	36
Features of Winding Selection		67
For Type FS-1378C	27. 1. 1	90
For Type FS-200A	27. 1. 2	91
FUNCTION OF POTENTIOMETERS AND SHUNT CONNECTOR	30. 1	98
FUNCTIONS OF DIP SWITCHES AND SELECT CONNECTORS	41. 1	124
FUNCTIONS OF THE SETTING PANEL	9. 1	37
G Gear Ratio Setting	11. 1. 8	48
H H-G, M-G, L-G Adjustment	30. 3. 3	103
H-SPD, L-SPD Adjustment	30. 3. 6	105
H-T Adjustment	30. 3. 4	104
Home Mode Display	9. 3. 1	38
HOW TO CALCULATE ACCELERATION AND DECELERATION TIME	APPENDIX A	136
HOW TO CALCULATE GD ²	APPENDIX B	138
I Incremental Positioning	37. 2. 3	115
INSTALLATION	6. 3	30
INSTALLING MAGNETO AND MAGNETIC SENSOR	28. 2	95
Installing Spindle AC Motor	6. 3. 1	30
Installing Controller	6. 3. 2	30
INTERCONNECTIONS	4. 1	9
INTERCONNECTIONS	19. 1	74
INTERCONNECTIONS BETWEEN DEVICES	27. 1	90
INTERCONNECTION DIAGRAM	38. 1	116
K KEY OPERATION AND LED DISPLAY	9. 3	38
L L-T Adjustment	30. 3. 5	104
LEAD SPECIFICATIONS	4. 3	12
LED DISPLAY	31	106
LED DISPLAY AND OPERATION KEYS	9. 2	37
List of Connector Signal Pins	27. 1. 3	91
Load Meter Full Scale Setting	11. 1. 1	46
LVL Adjustment	30. 3. 1	103
M M-code Method	12. 3. 1	80
MAGNETIC CONTACTOR FOR WINDING SELECTION	22	83
Magnetic Sensor	28. 1. 3	94
Magnetic Sensor Type Spindle Orientation		85
Magneto	28. 1. 2	94
MAINTENANCE	13	52

INDEX (Cont'd)

Subject	Section No.	Page
M Mechanical Specifications	2.3.2	7
MOTOR CHARACTERISTICS	21.1	78
MOTOR DIMENSIONS AND MOUNTING CONDITIONS	18	72
MOTOR DIMENSIONS mm	18.1	72
MOTOR MECHANICAL CHARACTERISTICS	2.3	7
MOTOR MECHANICAL SPECIFICATIONS	17.2	71
M-SPD Adjustment	30.3.7	105
N Normal Mode	26.2.1	89
NOTES	21.4	82
O OPERATION	10.4	45
OPERATION	21	78
OPERATION	22.3	83
Operation of Switches and Displays	41.2.1	125
OPERATION ON THE SETTING PANEL	9	37
OPERATION OUTLINE	37	112
OPTICAL ENCODER (PG) PULSE OUTPUT CIRCUIT	5.4	26
Orientation Card	28.1.1	93
ORIENTATION CARD	40.1	123
ORIENTATION CONTROL	26.1	88
ORIENTATION CONTROL OUTLINE	37.1	112
ORIENTATION OPERATION	26.2	89
ORIENTATION OPERATION	37.2	113
Orientation Speed	41.4.5	132
OUTLINE OF OPERATION	26	88
OUTPUT POWER–SPEED CHARACTERISTICS	2.1	5
OUTPUT POWER, TORQUE VS MOTOR SPEED	17.1	69
P PERIODIC CLEANING	13.2	52
PERIODIC INSPECTION	13.3	53
Position Control Proportional Gain	41.4.4	132
Positioning End Detection Width and Cancellation Width	41.4.2	131
Potentiometers Adjusted before Shipment	30.1.2	98
PRINTED CIRCUIT BOARD LAYOUT	7.2	33
PRECAUTIONS IN MOUNTING	28.3	96
PRECAUTIONS ON WIRING	38.3	118
PREPARATION FOR OPERATION	8	34
Prolonged Storage	13.3.1	54
PROTECTION FUNCTIONS	1.3	4
R Rated Speed Setting	11.1.4	46
RATINGS AND SPECIFICATIONS	1	1
RATINGS AND SPECIFICATIONS	22.1	83
Replacement of Base Drive Board	13.5.2	58
Replacement of Control Circuit Board	13.5.1	56
REPLACEMENT OF ORIENTATION BOARD	33	107
REPLACEMENT OF PRINTED CIRCUIT BOARDS	13.5	56
Return to the Home Mode	9.3.5	39
S Selection of Connector Setting	30.1.3	99
SEQUENCE INPUT SIGNAL	5.1	16
SEQUENCE OUTPUT SIGNAL	5.3	23
SETTING	11.1	46
SETTING AND ADJUSTMENT	11	46

INDEX (Cont'd)

Subject	Section No.	Page
S SETTING EACH PART	41. 4	131
SETTING OF CONTROL CONSTANTS MONITORING OF CONTROL SIGNALS	41. 2	125
Soft Start Time Setting	11. 1. 3	46
SPARE PARTS	15	66
SPECIFICATIONS	16	68
SPECIFICATIONS	24	85
SPECIFICATIONS	35	109
Speed Coincidence Range Setting	11. 1. 7	47
SPEED REFERENCE	5. 2	20
Speed Detection Level	11. 1. 5	47
SPINDLE ORIENTATION SPECIFICATIONS	24. 1	85
SPINDLE ORIENTATION SPECIFICATIONS	35. 1	109
Spindle Origin	41. 4. 1	131
STANDARD SPECIFICATIONS	1. 1	1
STATE DISPLAY	10. 2	43
STATUS MONITORING FUNCTIONS	1. 2	3
SYSTEM CONFIGURATION	25	87
T Test Mode	26. 2. 2	90
Test Mode	37. 2. 1	113
TEST RUN	10	42
Thyristor Module	13. 4. 2	55
Torque Detection Level Setting	11. 1. 6	47
TORQUE--SPEED CHARACTERISTICS	2. 2	6
Trace-back Display	9. 3. 3	38
Transistor Module	13. 4. 1	54
TROUBLESHOOTING	14	60
TROUBLESHOOTING	23	84
TROUBLESHOOTING	42	134
TROUBLESHOOTING FOR SPINDLE ORIENTATION SYSTEM	34	108
V VS-626MT ^{III} CHECK TERMINALS AND THEIR SIGNALS	12	51
VS-626MT ^{III} Controller	10. 1. 2	42
VS-626MT ^{III} CONTROLLER DIMENSIONS	6. 2	29
W WINDING SELECTION OPERATION	21. 2	79
WINDING SELECTION PROCEDURES	21. 3	79
WIRING	4	9
WIRING	19	74
WIRING DIAGRAM	38	116
WIRING INSTRUCTIONS	4. 4	13
WIRING SPECIFICATIONS	27	90

1. RATINGS AND SPECIFICATIONS

1.1 STANDARD SPECIFICATIONS

Table 1.1 Standard Specifications of AC Spindle Motor

Model		UAASKA-□CA1 (Flange-mounted Type), UAASKA-□CA3 (Foot-mounted Type)							*
		04†	06	08	11	15	19	22	30
Rated† Output Power kW (HP)	30-minute Rating [50% ED] (HP) [Current]	3.7 (5) [32]	5.5 (7.5) [39]	7.5 (10) [46]	11 (15) [62]	15 (20) [90]	18.5 (25) [96]	22 (30) [112]	30 (40) [166]
	Continuous Rating (HP) [Current]	2.2 (3) [23]	3.7 (5) [29]	5.5 (7.5) [37]	7.5 (10) [46]	11 (15) [71]	15 (20) [82]	18.5 (25) [99]	22 (30) [131]
Rated Speed r/min	Base Speed	1500 (40 to 1500 r/min : constant torque)							1150 (40 to 1150 r/min : constant torque)
	Maximum Speed	8000 (1500 r/min or more : constant torque)			6000 (1500 r/min or more : constant torque)				4500 (1500 r/min or more : constant torque)
Output Torque at Base Speed (Continuous Rated Current)	N·m	14.0	23.5	35.0	47.7	70.0	95.0	117.6	182.4
	kgf·m lb·ft	1.43 10.4	2.40 17.4	3.57 25.8	4.87 35.8	7.14 51.7	9.74 70.6	12.0 86.9	18.6 134
Rotor Inertia (J)	kg·m ²	0.0095	0.021	0.03	0.055	0.0725	0.10	0.12	0.3375
	lb·ft ²	0.90	1.99	2.85	5.22	6.88	9.49	11.4	32.1
Overload Capacity	120%, 60 s of 30-minute rating (50%ED)								
Cooling Method	Single-phase, 200VAC, 50 or 60 Hz; 220VAC, 50 or 60 Hz; 230VAC, 60 Hz								
Insulation	Class F								
Ambient Temperature, Humidity	0 to +40°C, 32 to 104°F, 95% RH or below								
Vibration	V-5							V-10	
Noise Level	75 dB (A) or below					80 dB (A) or below			
Paint Color	Munsell notation N1.5								
Speed Detector	Magnetic encoder								
Approx. Mass kg (lb)	35 (77)	55 (121)	67 (148)	90 (199)	105 (232)	130 (287)	150 (331)	260 (574)	

* UAASKJ-□CA1 (Flange-mounted type), UAASKJ-□CA3 (Foot-mounted type)

† Rated output power is guaranteed when input voltage is 200 V 50/60Hz, 220 V 50/60Hz, or 230 V 60Hz.

‡ If input voltage is lower than 200 V, rated output power is not guaranteed.

§ 15-minute rating (50% ED)/continuous rating for 3.7/2.2 kW

MODEL DESIGNATION

• AC SPINDLE MOTOR

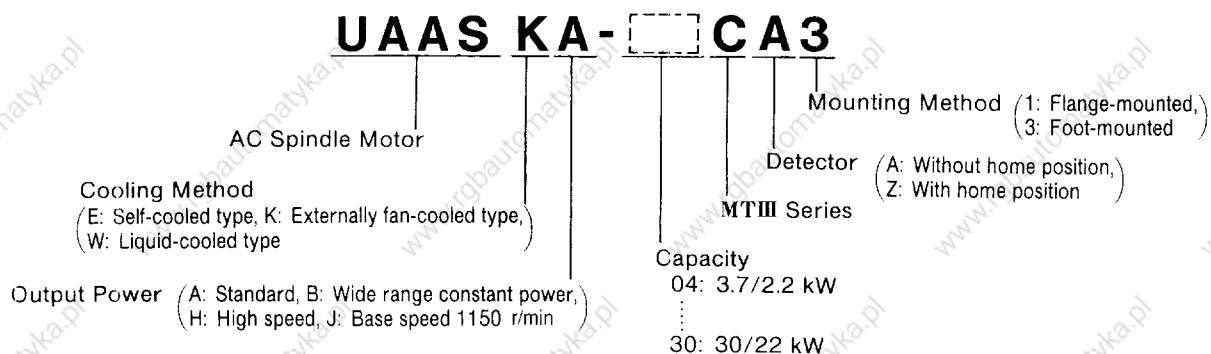

1. 1 STANDARD SPECIFICATIONS (Cont'd)

Table 1. 2 Standard Specifications of VS-626MTIII Controller

Type CIMR-MTIII-□		3.7 K	5.5 K	7.5 K	11 K	15 K	18.5 K	22 K	30 K
Power Supply		Three-phase, 200VAC, 50 or 60Hz; 220VAC, 50 or 60Hz; 230VAC, 60Hz (Voltage fluctuation: +10 to -15%)							
Max Required Power Supply (at 30-minute Rating)	kVA	7	9	12	19	24	30	36	48
Dissipated Power (Continuous Rating/30-minute Rating)	W	230/330	320/400	400/520	530/750	780/1030	900/1080	1120/1320	1440/1970
Circuit		PWM transistor inverter control							
Control Method		Vector control							
Braking Method		Regenerative braking							
Speed Adjustable Range		40 to 8000 r/min (1 : 200)			40 to 6000 r/min (1 : 150)			40 to 4500 r/min (1 : 112)	
Speed Regulation		0.2% maximum speed or below (load variation: 10 to 100%)							
Overload Capacity		120%, 1 minute of 30-minute rating (50% ED)							
Speed Command Input	Analog	±10VDC (+ forward and - reverse) or +10VDC (forward and reverse signals)							
	Digital	Binary 12-bit, BCD 2-digit or 3-digit							
Ambient Temperature	At Operation	0 to +55°C (32 to 131°F)							
	At Storage #	-20 to +60°C (-4 to 140°F)							
Humidity		95% RH or below (non-condensing)							
Allowable Vibration		1G at 20Hz or below, 0.2G at 20 to 50Hz							
Finish in Munsell Notation		5Y 7/1							
Installation		Indoor-use, free from dirt, dust, liquid, harmful gases, etc.							
Standards		Comply with JIS*, JEM†, JEC‡							
Approx Mass kg (lb)	Self-cooled Type for Totally-enclosed Panel	16 (35.3)	32 (70.5)	36 (79.4)	51 (112.5)	55 (121.3)	80 (176.4)		
	Panel-installed Type	19 (41.9)	36 (79.4)	40 (88.2)	57 (125.7)	61 (134.5)	87 (191.8)		

*JIS: Japanese Industrial Standard

†JEM: The Standard of Japan Electrical Manufacturers' Association

‡JEC: Standard of Japanese Electrotechnical Committee

: Temperature during shipping

MODEL DESIGNATION

• CONTROLLER

CIMR-MTIII-□K

Inverter

VS-626MTIII
Series Name

Max Applicable Motor Output
3.7: 3.7 kW

⋮
30: 30 kW

1.2 STATUS MONITORING FUNCTIONS

The VS-626MTIII has many status monitoring functions to monitor the operation status of the spindle drive (Table 1.3). Each operation status is displayed by the LEDs on the setting panel of the control printed circuit board by operation of the key switches on the setting panel.

Table 1.3 Status Monitoring Functions

LED Display	Code	Name	Unit	Display at Power ON
<i>Un-01</i>	NFB	Motor speed	r/min	0
<i>Un-02</i>	NREF	Speed command	%	000
<i>Un-03</i>	TREF	Torque command	%	00
<i>Un-04</i>	MTEMP	Motor temperature	°C	Approx. ambient temperature
<i>Un-05</i>	STATUS	Internal state	Hexadecimal	Varies depending on internal state
<i>Un-06</i>	ALM	Alarm state	Hexadecimal	0000
<i>Un-07</i>	DIDSP	Interface input state	Bit	Varies depending on input signal state
<i>Un-08</i>	DODSP	Interface output state	Bit	000000
<i>Un-09</i>	NFBS	Spindle speed	r/min	0
<i>Un-10</i>	FLUX	Magnetic flux command	%	250

Note: *Un-01* to *-08* are trace-back data. (Refer to Par. 9.3.3 "Trace-back Display.")

1.3 PROTECTION FUNCTIONS

In case a malfunction occurs during operation, the malfunction state is displayed by the LEDs of the setting panel according to the malfunction, as shown in Table 1.4, and operation puts on hold. In case multiple malfunctions occur, the malfunctions are recorded in the order they occurred. This will be useful for analysis of the cause of malfunction.

Table 1.4 Protection Functions

No.	LED * Display	Code	Name	Alarm Cord			
				AC3	AC2	AC1	AC0
1	ESP	EMGSTP	Emergency stop error	1	1	1	1
2	OC	OC	Overcurrent	1	1	1	0
3	MCCB	MCCB	MCCB trip	1	1	0	1
4	RGOC	RGOC	Regenerative overcurrent	1	1	0	0
5	OV	OV	Overvoltage	1	0	1	1
6	OS	OS	Overspeed	1	0	1	0
7	UV	UV	Undervoltage	1	0	0	1
8	OL	OL	Overload	1	0	0	0
9	DEV	DEV	Excessive speed deviation	0	1	1	1
10	MOH	MOH	Motor overheat				
11	THMSTA	THMSTA	Thermo detector disconnection	0	1	1	0
12	FOH	FOH	Controller overheat				
13	FU	DCFU	DC circuit fuse blown	0	1	1	0
		ISO.AMP	Base drive ISO.AMP error.				
14	AD	AD	16-bit AD defective	0	1	0	0
15	CPU-AD	CPU-AD	CPU AD defective				
16	PG	PG	PG disconnection*	0	0	1	1
17	PGC	PGC	PG counter defective				
18	PROM	PROM	PROM error	0	0	1	0
19	RAM-I	RAM-I	Internal RAM error				
20	RAM-E	RAM-E	External RAM error	0	0	0	1
21	RAM-N	RAM-N	NV-RAM error				
22	· · · · ·	CPF	Control function failure	0	0	0	0
23	CHE	CHE	Winding selection error†	1	1	1	1

*Trouble indication, "—" , is shown as the first malfunction.

*When motor does not move during operation (e.g. motor rock, disconnecting of motor side, fuse blown inside base driver), PG indication (PG disconnection) appears.

*If control function failure (CPF) occurs, shut off the power, and then turn on the power again. If CPF still continues, replace control board.

† This function is only winding selection system.

2. CHARACTERISTICS (COMBINATION WITH STANDARD MOTOR)

2.1 OUTPUT POWER—SPEED CHARACTERISTICS

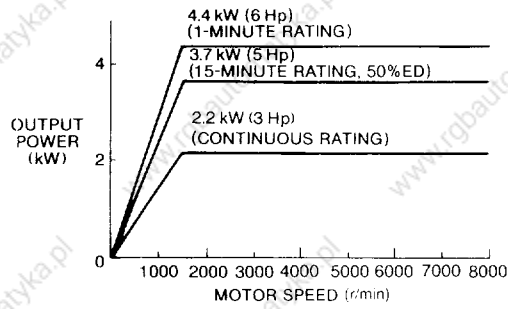

(a) 3.7/2.2 kW (5/3 HP)

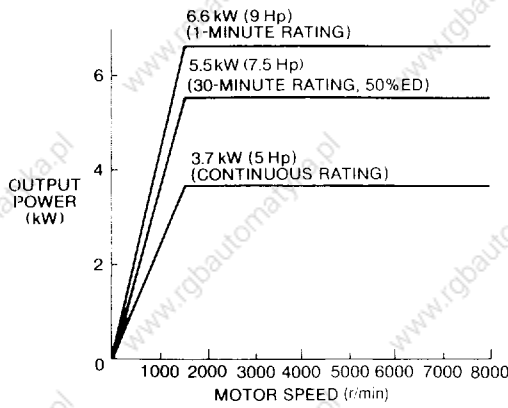

(b) 5.5/3.7 kW (7.5/5 HP)

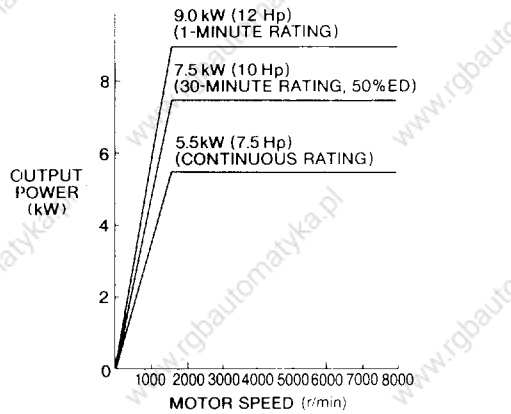

(c) 7.5/5.5 kW (10/7.5 HP)

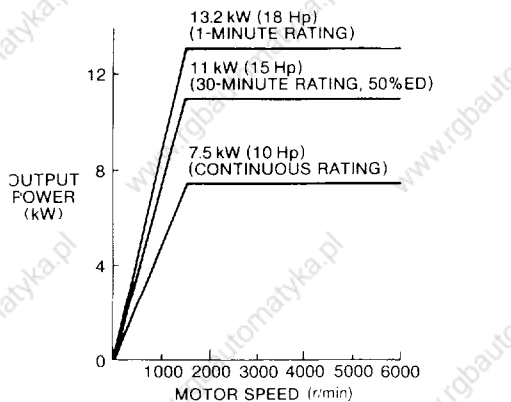

(d) 11/7.5 kW (15/10 HP)

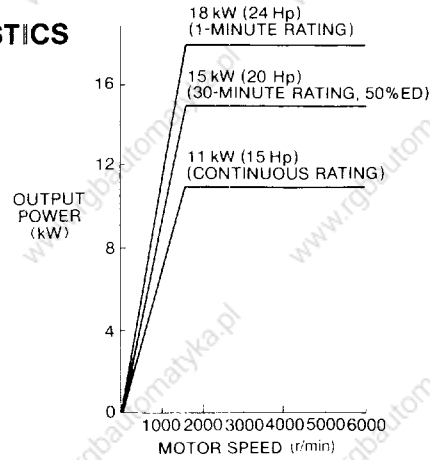

(e) 15/11 kW (20/15 HP)

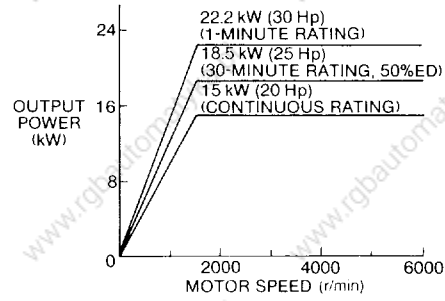

(f) 18.5/15 kW (25/20 HP)

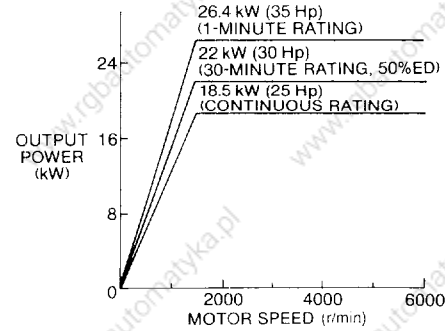

(g) 22/18.5 kW (30/25 HP)

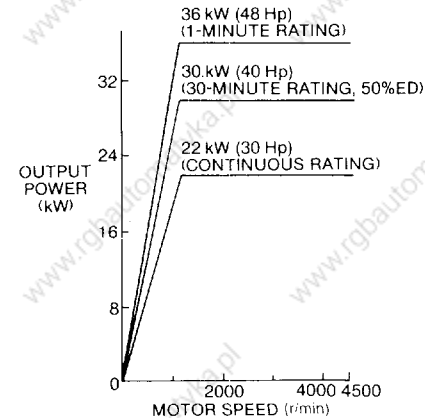

(h) 30/22 kW (40/30 HP)

Fig. 2.1 Output Power—Speed Characteristics

2.2 TORQUE—SPEED CHARACTERISTICS

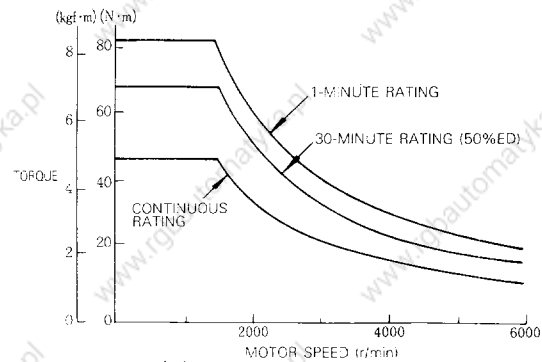
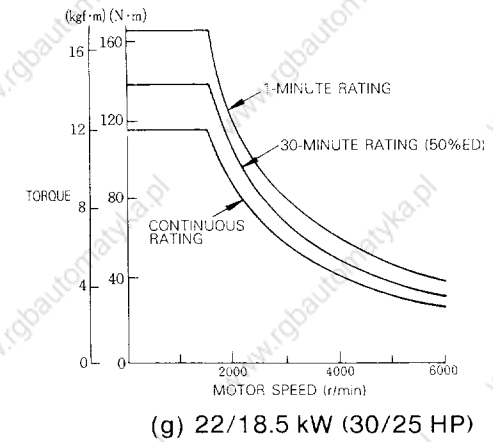
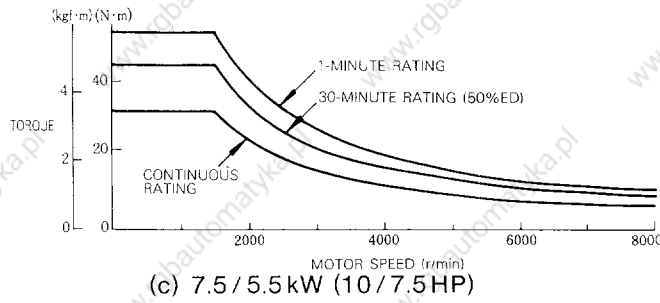
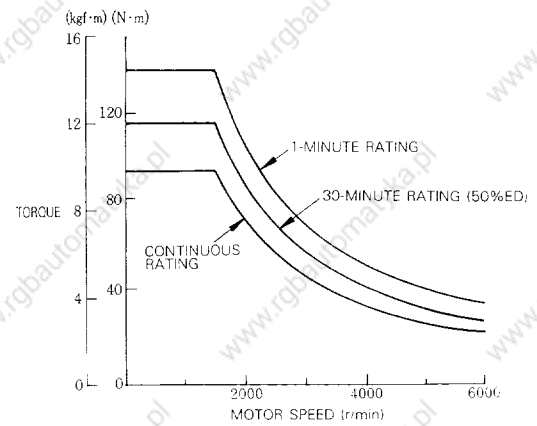
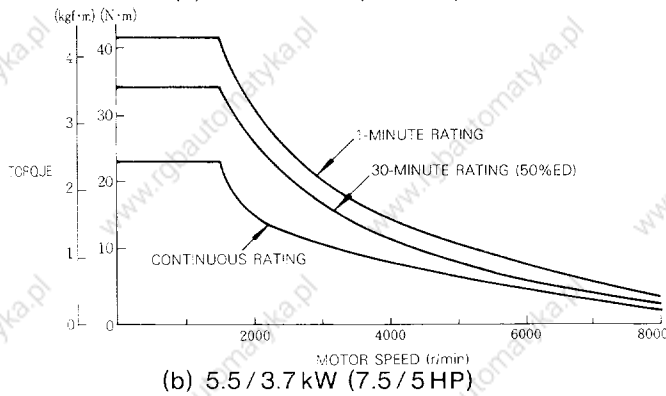
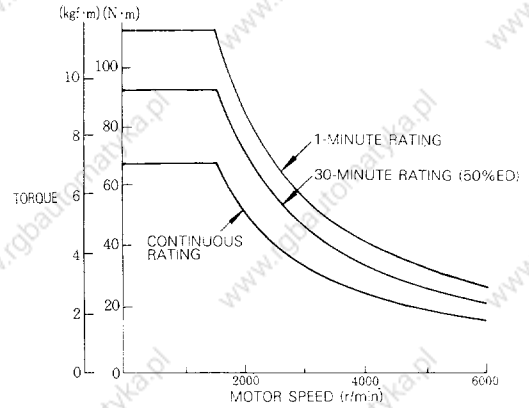
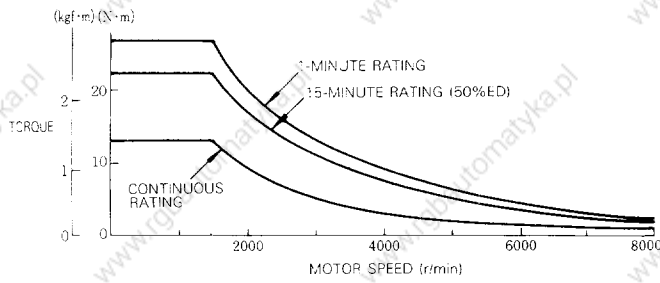

(h) 30/22 kW (40/30 HP)

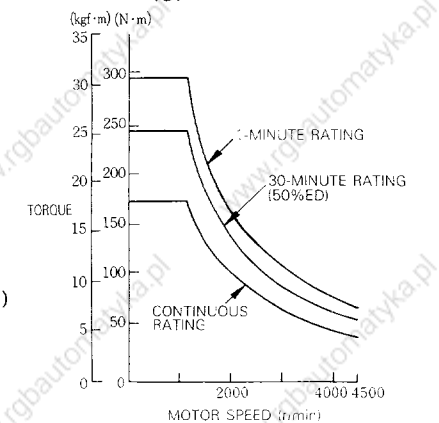

Fig. 2.2 Torque-Speed Characteristics

2.3 MOTOR MECHANICAL CHARACTERISTICS

2.3.1 Allowable Radial Load

Table 2.1 shows allowable radial load according to AC spindle motor types. Allowable radial load means maximum values of the load applying to the shaft extension.

Table 2.1 Allowable Radial Load

Motor Model UAASK-□CA1, -□CA3	Rated Output kW (Hp)	Allowable Radial Load kg (lb)
04	3.7/2.2 (5/3)	90 (198)
06	5.5/3.7 (7.5/5)	180 (397)
08	7.5/5.5 (10/7.5)	
11	11/7.5 (15/10)	270 (595)
15	15/11 (20/10)	
19	18.5/15 (25/20)	270 (595)
22	22/18.5 (30/25)	340 (750)
30*	30/22 (40/30)	500 (1103)

* The model of 30 is UAASKJ.

2.3.2 Mechanical Specifications

Table 2.2 Foot-Mounted Type

	Accuracy (T.I.R)* (Rated Output)
Parallel to Shaft	0.03 mm (Less than 7.5/5.5 kW)
	0.033 mm (11/7.5 to 22/18.5 kW)
	0.042 mm (30/22 kW)
Shaft Run Out	0.02 mm (Less than 7.5/5.5 kW)
	0.022 mm (11/7.5 to 22/18.5 kW)
	0.028 mm (30/22 kW)

*T.I.R (Total Indicator Reading)

Table 2.3 Flange-Mounted Type

	Accuracy (T.I.R)* (Rated Output)
Flange Surface Perpendicular to Shaft	0.04 mm (Less than 22/18.5 kW)
	0.06 mm (30/22 kW)
Flange Diameter Concentric to Shaft	0.04 mm (Less than 7.5/5.5 kW)
	0.046 mm (11/7.5 to 22/18.5 kW)
	0.048 mm (30/22 kW)
Shaft Run Out	0.02 mm (Less than 7.5/5.5 kW)
	0.022 mm (11/7.5 to 22/18.5 kW)
	0.028 mm (30/22 kW)

*T.I.R (Total Indicator Reading)

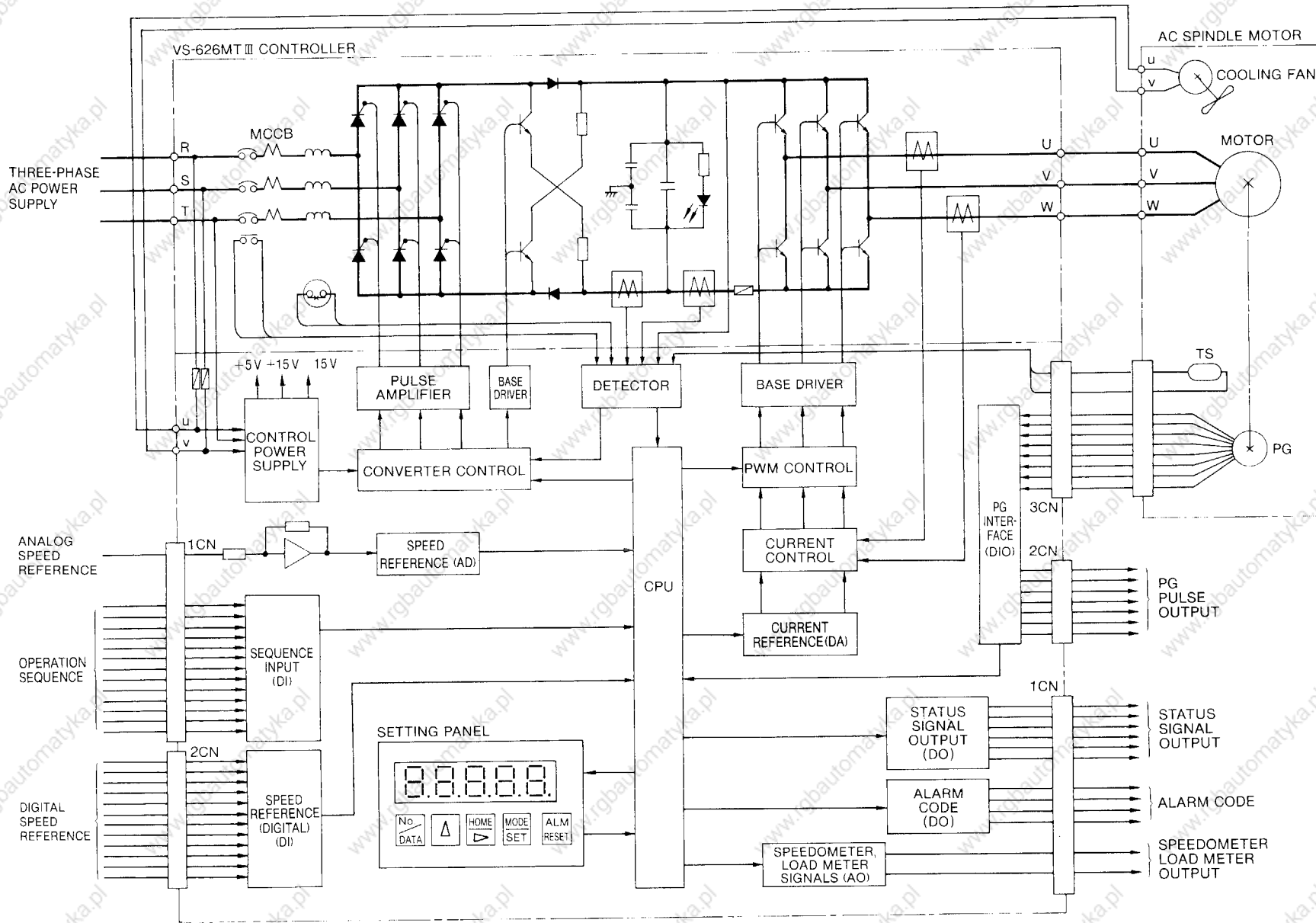

3. BLOCK DIAGRAM

Fig. 3.1 Block Diagram of VS-626MT III

4. WIRING

4.1 INTERCONNECTIONS

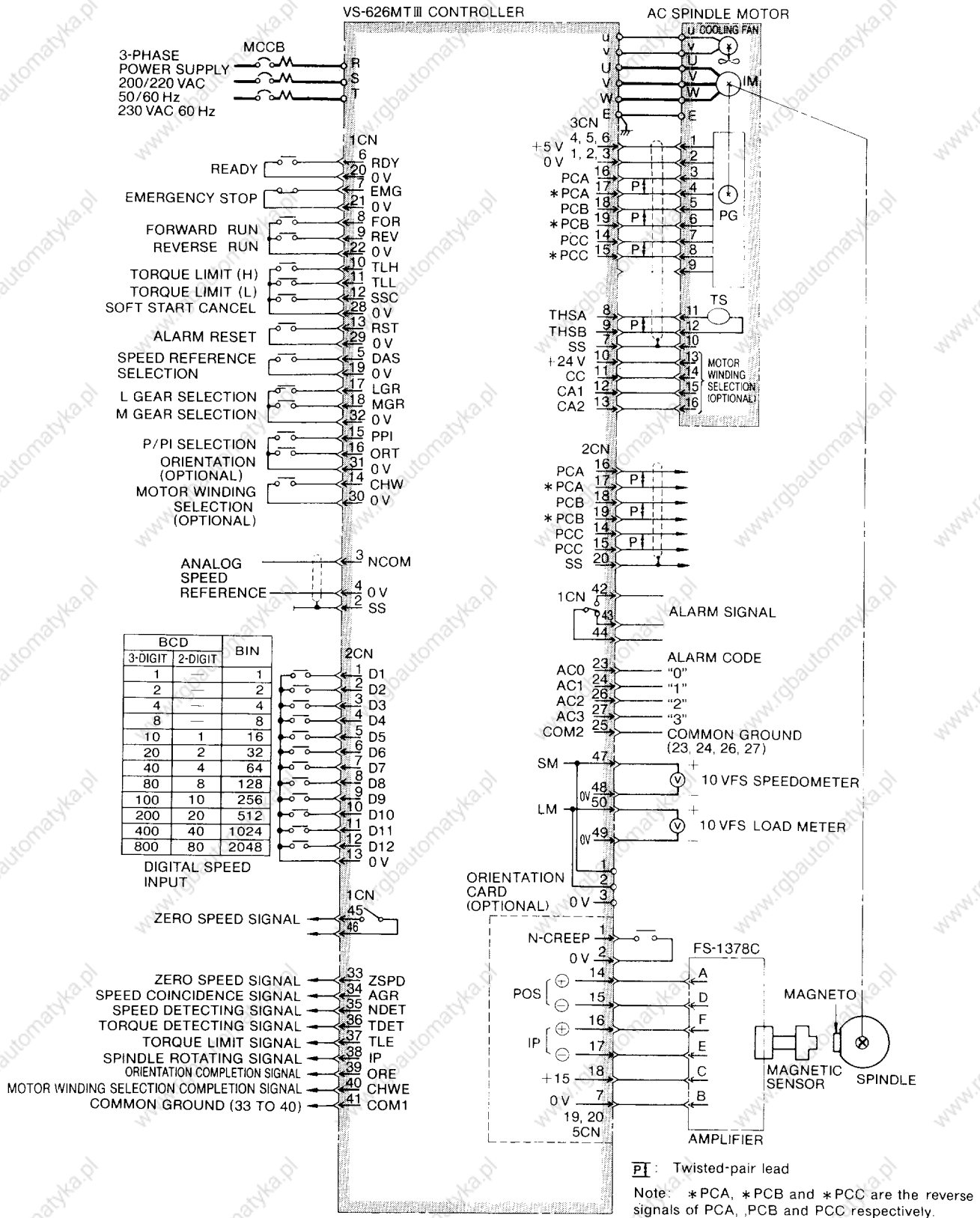

Fig. 4.1 Wiring Diagram of VS-626MT III Drive

4.2 CONNECTOR SIGNAL LIST

Table 4.1 1 CN Signal List

Pin No.	Signal	Pin No.	Signal
1	+ 15 V	26	Alarm code output bit 2
2	SS	27	Alarm code output bit 3
3	Analog speed reference (N COM)	28	0 V
4	0 V	29	
5	Speed reference selection (DAS)	30	
6	Ready (RDY)	31	
7	Emergency stop (EMG)	32	
8	Forward run (FOR)	33	Zero speed (ZSPD)
9	Reverse run (REV)	34	Speed coincidence (AGR)
10	Torque limit signal H (TLH)	35	Speed detecting (NDET)
11	Torque limit signal L (TLL)	36	Torque detecting (TDET)
12	Soft start cancel (SSC)	37	Torque limit (TLE)
13	Alarm reset (RST)	38	Spindle rotating signal
14	Motor winding selection (CHW)	39	Orientation completion (ORE)
15	P/PI selection (PPI)	40	Motor winding selection completion (CHWE)
16	Orientation command (ORT)	41	Common ground Pin No (33 to 40)
17	L gear selection (LGR)	42	Alarm signal contact output
18	M gear selection (MGR)	43	
19	0 V	44	
20		45	Zero speed contact output
21		46	
22		47	Speedometer signal
23	Alarm code output bit 0	48	0 V
24	Alarm code output bit 1	49	0 V
25	Alarm code output common	50	Load meter signal

Table 4.2 2 CN Signal List

Pin No.	Signal	Pin No.	Signal
1	Digital speed reference (D1)	11	Digital speed reference (D11)
2	Digital speed reference (D2)	12	Digital speed reference (D12)
3	Digital speed reference (D3)	13	0 V
4	Digital speed reference (D4)	14	Pulse generator output (PCC)
5	Digital speed reference (D5)	15	Pulse generator output (*PCC)
6	Digital speed reference (D6)	16	Pulse generator output (PCA)
7	Digital speed reference (D7)	17	Pulse generator output (*PCA)
8	Digital speed reference (D8)	18	Pulse generator output (PCB)
9	Digital speed reference (D9)	19	Pulse generator output (*PCB)
10	Digital speed reference (D10)	20	Shield sheath (SS)

Table 4.3 3 CN Signal List

Pin No.	Signal	Pin No.	Signal
1	0 V	11	Motor winding selection (optional) (CC)
2		12	Motor winding selection (optional) (CA1)
3		13	Motor winding selection (optional) (CA2)
4	+ 5 V	14	Pulse generator input (PCC)
5		15	Pulse generator input (*PCC)
6		16	Pulse generator input (PCA)
7	Shield sheath (SS)	17	Pulse generator input (*PCA)
8	Thermo detector input (THSA)	18	Pulse generator input (PCB)
9	Thermo detector input (THSB)	19	Pulse generator input (*PCB)
10	+ 24 V	20	Frame ground (FG)

* Shows the reverse signals.

4.3 LEAD SPECIFICATIONS

Power lead type, size and terminal screw are listed in Table 4.4. Cooling fan motor power leads are shown in Table 4.5. Control signal lead and connectors are listed in Table 4.6.

Table 4.4 Power Lead Specifications

VS-626MTIII Type CIMR-MTIII-[]	Lead		VS-626MTIII Controller		Motor	
	Type	Size mm ² (AWG)	Terminal	Terminal Screw	Terminal	Terminal Screw
3.7 K	600 V cabtyre cable	5.5 (10)	Input: R, S, T, E Output: U, V, W, E	M 5	Input: U, V, W, E	M 4
5.5 K						M 5
7.5 K		8 (8)				M 8
11 K		14 (6)				M 8
15 K		22 (4)		M 8		
18.5 K		30 (2)		M 8		
22 K		38 (1)		M 8		
30 K		50 (1/0)		M 8		

Table 4.5 Cooling Fan Motor Power Lead Specifications

Application	Lead		Terminal	Terminal Screw
	Type	Size mm ² (AWG)		
Cooling fan power lead	600 V vinyl-insulated lead	2 (14)	U, V	M 4

Table 4.6 Control Signal Lead and Connector Specifications

Connector Code	Application	Connector		Lead
		Type MR-	Manufacturer	Size
1CN	I/O interface (1)	50LF	Honda Tsushin Kogyo Co., Ltd.	0.3 mm ² coaxial 50-core* (22 AWG)
2CN	I/O interface (2)	20LM		0.3 mm ² twisted lead 4-pairs (22 AWG)
3CN	Motor interface	20LF		0.3 mm ² twisted lead* (22 AWG)

*Except for analog signal lines, signal line 1CN may also be in conventional vinyl lead [0.5 mm² (20 AWG)] for electric appliances, provided the following are observed.

- To minimize adverse effects of noise, the signal lead and the power lead should be separately run through as short a passage as possible. The signal lead should be 20 meters or below.
- The outer diameter of the cable bundle must be smaller than the size of the connector outlet opening given below.

Type MR-50LF: 16 mm (0.636 inches) diameter

Type MR-20LF: 11 mm (0.433 inches) diameter

* Use the composite cables KQVV-SW (22 AWG × 3 cores, 26 AWG × 6 pairs) made by Fujikura Cable Works, Ltd.

4. 4 WIRING INSTRUCTIONS

Complete VS-626MTIII interconnections, following the instructions given below.

(1) Control signal leads (1CN to 3CN) must be separated from main circuit leads (R, S, T, U, V, W) and other power lines and power supply lines to prevent erroneous operation caused by noise interference.

(2) Use the twisted shielded lead for the control signal line, and connect the shield sheath to any of the controller terminals. See Fig. 4.2. It is recommended that the wiring distance of the signal leads be 20 meters or below.

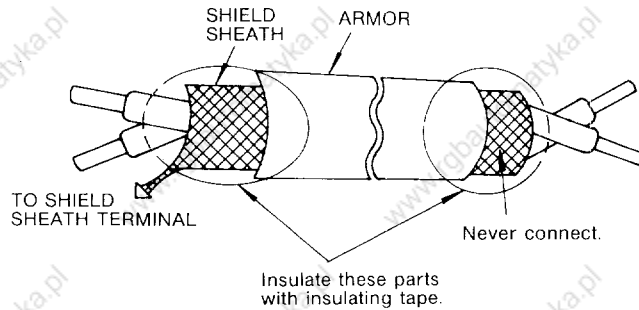

Fig. 4.2 Shielded Lead Termination

(3) Make a positive grounding using ground terminal E on the casing of VS-626MTIII.

- Ground resistance should be 100Ω or less.
- Never ground VS-626MTIII in common with welding machines, motors, and other large-current electrical equipment, or ground pole. Run the ground lead in a separate conduit from leads for large-current electrical equipment.
- Use ground lead listed in Table 4.4 and make the length as short as possible.
- Even when VS-626MTIII is grounded through its mountings such as channel base or steel plate, be sure to ground VS-626MTIII using the ground terminal E.
- Where several VS-626MTIII units are used side by side, all the units should preferably be grounded directly to the ground poles. However, connecting all the ground terminals of VS-626MTIII in parallel, and ground only one of VS-626MTIII to the ground pole is also permissible (Fig. 4.3). However, do not form a loop with the ground leads.

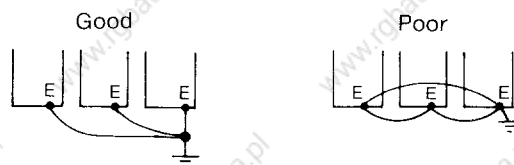

Fig. 4.3 Grounding of Three VS-626MTIII Units

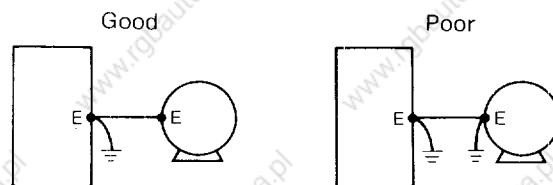

Fig. 4.4 Grounding of Motor and VS-626MTIII

4. 4 WIRING INSTRUCTIONS (Cont'd)

(4) Phase rotation of input terminals (R, S, T) is available to each direction, clockwise and counterclockwise.

(5) Never connect power supply to output terminals (U, V, W).

(6) Connect VS-626MTIII controller output terminals (U, V, W) to motor terminals (U, V, W).

(7) Care should be taken to prevent contact of wiring leads with VS-626MTIII cabinet, for short-circuit may result.

(8) Never connect power factor correction capacitor between the VS-626MTIII controller and motor.

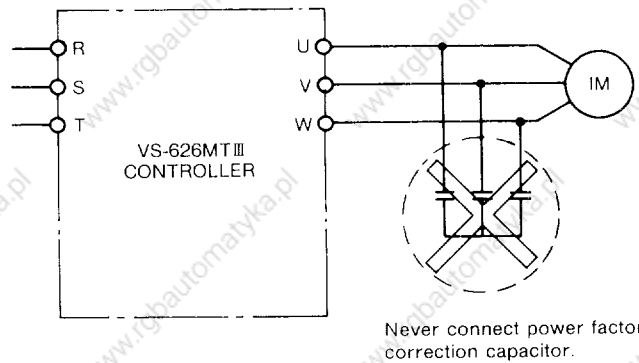

Fig. 4.5 Removal of Power Factor Correction Capacitor

(9) When applying a ground fault interrupter or relay, it should have good balance characteristics and be connected on the power supply side as shown in Fig. 4.6. Since the output from the VS-626MTIII controller contains higher-level harmonic components, a zero-phase current flows through the stray capacitor (C1) of the cable between VS-626MTIII controller and motor or through the stray capacitor (C2) of the motor, sometimes resulting in erroneous operation of the ground fault interrupter. Because of this, they must be installed in accordance with the following:

- Make the cable between the VS-626MTIII controller and motor as short as possible and reduce the steady state zero-phase current.
- Set the ground fault interrupter to a value larger than the rated current.
- Use a ground fault interrupter which is designed for inverter or is not operated by impulse waves.

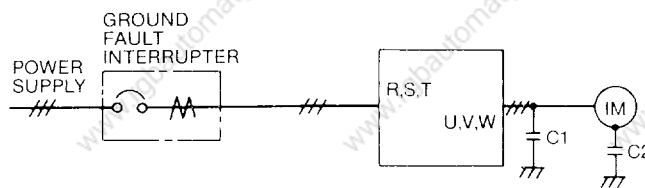

Fig. 4.6 Installation of Ground Fault Interrupter

(10) If both the VS-626MTIII controller and magnetic contactor are placed in the same control panel, the controller may sometimes operate erroneously due to the noise generated from the coil of the magnetic contactor. Connect a surge absorber in parallel with the coil of the magnetic contactor. The surge absorber will absorb the energy stored in the coil of magnetic contactor and thus must have a capacity suited to the coil. Yaskawa's magnetic contactors and surge absorbers are shown in Table 4.7.

CAUTION

Never connect surge absorbers to the output terminals (U, V, W) of the controller.

Table 4.7 Surge Absorbers

Magnetic Contactor and Control Relay Type		Surge Absorber*		
		Type	Specifications	Code No.
200 V Class	Magnetic-contactor† HI-10E, -20E, -25E, -35E, -50E, -65E ₂ , -80E ₂ , -125E ₂	DCR2-50A22E	250 VAC 0.5 μF + 200 Ω	C002417
	Control Relay RA-6E ₂ , RL-33E†			
	Control Relay LY-2, -3† HH-22, -23‡ MM-2, -4‡	DCR2-10A25C	250 VAC 0.1 μF + 200 Ω	C002482

*Made by MARCON Electronics. Co., Ltd.

For contactors other than those listed above, use the following surge absorbers:

- For 200 V class: Type DCR 2—50A22E

†Made by Yaskawa Controls Co., Ltd.

‡Made by Omron Corporation.

‡Made by Fuji Electric Co., Ltd.

5. CONTROL SIGNAL

5.1 SEQUENCE INPUT SIGNAL

When designing input signals, take the following conditions into consideration.

- When relay contacts, etc. are used, the contact capacity must be 30 V or above (15 mA or above).
- The filter in the level shifter circuit in the input section causes approximately 5 ms delay in the signals.
- Since a pull-up resistor is incorporated in the circuit, contactless signals can also be inputted. In this case, input signals 20 V or above for the HIGH level, and 2 V or below for LOW level.
- Fig. 5.1 shows the input interface circuit, and Table 5.1 gives the signal functions.

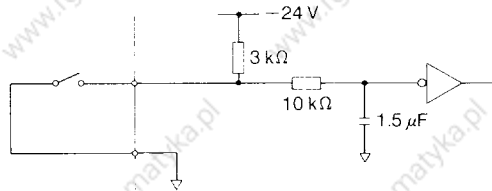
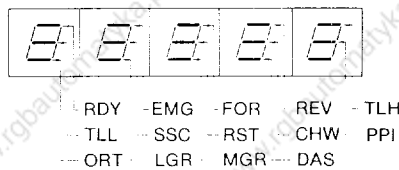

Fig. 5.1 Input Interface Circuit

- The ON/OFF state of the input signal can be checked by the LED display on the setting panel (Use mode $\text{U}_n\text{-}\square\square$). See Fig. 5.2 for the display. See par. 9 for operation.



Note: ON status-input signal lights.

Fig. 5.2 Display of Input State

Table 5.1 Functions of Sequence Input Signals

Signal	Connector No.	Pin No.	On Signal	Function
Ready $\overline{\text{RDY}}$	1 CN	6	CLOSE	<ul style="list-style-type: none"> • The main circuit is established with $\overline{\text{RDY}}$ closed, so the base block reset conditions are satisfied approximately 2.5 seconds after $\overline{\text{RDY}}$ is closed. • When $\overline{\text{RDY}}$ is opened during run, base is blocked instantly, and the motor current is interrupted. • When $\overline{\text{RDY}}$ is opened, the motor cannot be re-started if $\overline{\text{FOR}}$ or $\overline{\text{REV}}$ is not opened once. • Where $\overline{\text{RDY}}$ is not used, connect ICN-pin No.6 to pin No. 20 (0 V). • In 2.5 seconds after $\overline{\text{EMG}}$, $\overline{\text{RDY}}$ are closed, the system becomes ready for operation.

Table 5.1 Functions of Sequence Input Signals (Cont'd)

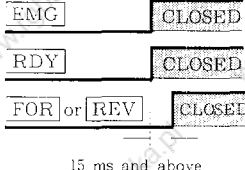
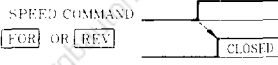
Signal	Connector No.	Pin No.	On Signal	Function												
Forward Run FOR Reverse Run REV	1 CN	8 9	CLOSE CLOSE	<p>With RDY and EMG closed and the speed reference positive, when FOR is closed, the motor runs CCW as viewed from drive end; and when REV is closed, the motor runs CW. Therefore, when speed reference and run signals are combined, the motor runs in the directions shown below.</p>  <p>386-76</p> <table border="1" data-bbox="811 655 1252 783"> <thead> <tr> <th colspan="2">Speed reference</th> <th>+</th> <th>-</th> </tr> </thead> <tbody> <tr> <td>Run Signal</td> <td>FOR</td> <td>CCW</td> <td>CW</td> </tr> <tr> <td></td> <td>REV</td> <td>CW</td> <td>CCW</td> </tr> </tbody> </table> <ul style="list-style-type: none"> When the signal is opened during run, the motor is stopped by the regenerative braking and when the motor speed reaches to zero, the motor current is interrupted by base blocking. The acceleration and deceleration time is set with the accel/decel constants (τ_{a-d} TSFS). The time between halt and 100 % rated speed can be set between 0.1 and 30 seconds. However, for some load GD^2 values, the set accel/decel time may be exceeded. FOR and REV should be closed at least 15 ms after EMG and RDY are closed. FOR and REV should not be closed ahead of EMG and RDY. When both FOR and REV are closed, the motor stops. In this case, if whichever of them becomes open, the motor resumes running, so that care must be taken to avoid accident.  <p>15 ms and above</p> <ul style="list-style-type: none"> When FOR or REV is closed, the motor runs at the speed specified by a speed reference.  <p>Be sure to first set a speed when running the motor. When a trouble occurs during run, base is blocked immediately to interrupt the motor current. </p>	Speed reference		+	-	Run Signal	FOR	CCW	CW		REV	CW	CCW
Speed reference		+	-													
Run Signal	FOR	CCW	CW													
	REV	CW	CCW													
Emergency stop EMG	1 CN	7	OPEN	<ul style="list-style-type: none"> When EMG is opened during run, the motor is quickly stopped by regenerative braking, and then, the current is interrupted. Even when the motor is not stopped, the current is automatically interrupted within the preset time (τ_{a-d}). When EMG is depressed, the motor cannot be restarted if FOR, REV or ORT with orientation card is not open once. When EMG is not to be used connect pin No.7 to pin No.21 (0V). 												

5. 1 SEQUENCE INPUT SIGNAL (Cont'd)

Table 5.1 Functions of Sequence Input Signals (Cont'd)

Signal	Connector No.	Pin No.	On Signal	Function
Torque Limit [TLH] [TLL]	1 CN	10 11	CLOSE CLOSE	<ul style="list-style-type: none"> This signal is for temporarily limiting the motor torque with a mechanically oriented spindle or gear shift. When [TLH] or [TLL] is closed, the torque is limited and the torque limit signal is output. Even if [TLH] and [TLL] are simultaneously closed, [TLL] will close before [TLH]. The torque limit level, [TLM] is preset by torque limit constant ([E0-09] EXTLIM) between 5 and 100 % of 30-minute rating. [TLL] level is a half of [TLH].  <ul style="list-style-type: none"> When [TLH] or [TLL] is not be used, leave pin Nos. 10 and 11 open.
Soft-start Cancel [SSC]	1 CN	12	CLOSE	<ul style="list-style-type: none"> This signal is for cancelling the soft start function so that speed reference is changed by speed command without delay, for inching or other special control modes. When [SSC] is closed, the accel/decel set time is neglected, and the motor is accelerated or decelerated in short time by the current limit accel/decel function. When [SSC] is not to be used, leave pin No.12 open.
Soft-start Cancel [SSC] [Servo Mode Signal]	1 CN	12	CLOSE	<ul style="list-style-type: none"> Selecting "1" on bit 10 of SELCD 1 ([E0-25]) permits change to servo mode. <p>SELCD 1</p> 
Speed Regulator P/PI Selection [PPI]	1 CN	15	CLOSE (P) OPEN (P I)	<ul style="list-style-type: none"> This signal is for selecting P/PI control of speed regulator. When [PPI] is closed, the speed controller swithes to P control, regardless of the operation state. When not performing P control, leave pin No.15 open.

Table 5.1 Functions of Sequence Input Signals (Cont'd)

Signal	Connector No.	Pin No.	On Signal	Function
Speed Reference Selection Signal DAS	1 CN	5	OPEN (analog) CLOSE (digital)	<ul style="list-style-type: none"> The type of speed reference input [analog input (10 V/100 %) or digital input] is selected with this signal. When DAS is opened, it is analog speed reference, and when it is closed, it is digital speed input during base blocking. The following four can be selected for digital speed input (preset at the factory before delivery). <ul style="list-style-type: none"> 12-bit binary 3-digit BCD 2-digit BCD Internal speed setting These selections are determined by SELCD 1 (50-25)
Alarm Reset RST	1 CN	13	CLOSE ↓ OPEN	<ul style="list-style-type: none"> This signal is for restoring the run ready state after eliminating the cause of the tripping of the protective circuit, as the result of overload. RST is effective only after the tripping of a protecting circuit. While FOR or REV is closed, or ORT is closed, with orientation card resetting is not possible. The RST switch incorporated in the controller is equivalent to this signal in function. Resetting is effected at the edge of RST. Therefore, open RST if closed. In the protective circuit sequence, malfunction has priority. An example of the timing chart for resetting is given below. <p>The timing chart shows the sequence of events for resetting after a protective circuit trip. It includes signals for OVERLOAD PROTECTION (OL), FOR, RST, RUN, OL, MALFUNCTION SIGNAL, PROTECTIVE CIRCUIT TRIP, and RESET END. The chart illustrates how the RST signal is used to reset the system after a trip, even in the presence of other signals like FOR or OL.</p>

In addition, there are orientation command, L-gear selection and M-gear selection as sequence input signals. For details, see "Magnetic Sensor Type Spindle Orientation" on page 83.

5.2 SPEED REFERENCE

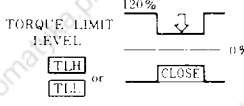
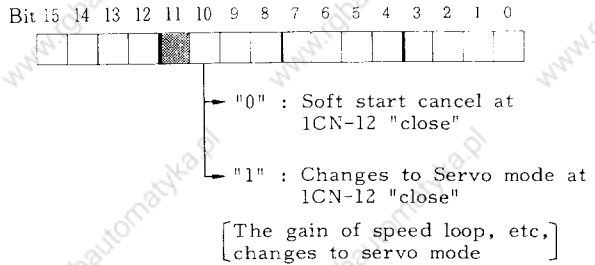
Table 5.2 Speed Reference Input

Signal	Connector No.	Pin No.	Function																																																																
Analog Reference [NCOM]	1 CN	3	<ul style="list-style-type: none"> Rated input voltage is ± 10 VDC. The allowable input voltage is ± 12 VDC. However, since the controller limits it at 105 % of rated value, the maximum speed of the motor is limited at 105 % of the rated speed. The input impedance of [NCOM] is 50 kΩ. With various combinations of [NCOM] and run signals, speeds and directions of rotation shown below are obtained. [NCOM] is effective and the motor runs when run signal [FOR] or [REV] is closed. While [FOR] or [REV] is on, sometimes the motor will not stop completely even when [NCOM] is set to 0 V. To stop the motor completely, open [FOR] or [REV] whichever is closed. (While either is closed, current flows.) To improve noise resistance, use shielded lead for the [NCOM] circuit. When setting [NCOM] manually, the reference voltage of the controller can be used, provided the current is kept up to 10 mA.  																																																																
Digital Speed Input (D1 to D12)	2 CN	1 to 12	<ul style="list-style-type: none"> Two types of speed settings (Internal speed setting and external digital speed setting) can be selected. The following three can be selected for digital speed inputs (preset at the factory before delivery). <ul style="list-style-type: none"> 12-bit binary 3-digit BCD 2-digit BCD 																																																																
		1 to 8	<p>Speed setting method is changed by the control constants (ξ_{0-25}) SELCD 1 bit.</p> <p style="text-align: center;">SELCD 1 Bit 15 14 13 12 11 10 9 8 7 6 5 4 3 2 1 0</p> <div style="text-align: center;"> <table border="1" style="margin: auto;"> <tr> <td style="width: 15px; height: 15px;"></td> <td style="width: 15px; height: 15px;"></td> <td style="width: 15px; height: 15px;"></td> <td style="width: 15px; height: 15px;"></td> <td style="width: 15px; height: 15px;"></td> <td style="width: 15px; height: 15px;"></td> <td style="width: 15px; height: 15px;"></td> <td style="width: 15px; height: 15px;"></td> <td style="width: 15px; height: 15px;"></td> <td style="width: 15px; height: 15px;"></td> <td style="width: 15px; height: 15px;"></td> <td style="width: 15px; height: 15px;"></td> <td style="width: 15px; height: 15px;"></td> <td style="width: 15px; height: 15px;"></td> <td style="width: 15px; height: 15px;"></td> <td style="width: 15px; height: 15px;"></td> </tr> </table> </div> <p style="text-align: center;">SELCD 1 is selected in hexadecimal.</p> <ul style="list-style-type: none"> Selecting method of speed setting <table border="1" style="width: 100%; border-collapse: collapse;"> <thead> <tr> <th>ICN-5, 19</th> <th colspan="4">SELCD 1 (ξ_{0-25})</th> <th>Speed Setting</th> </tr> <tr> <th>DAS</th> <th>Bit 3</th> <th>Bit 2</th> <th>Bit 1</th> <th>Bit 0</th> <th></th> </tr> </thead> <tbody> <tr> <td>OFF</td> <td>—</td> <td>—</td> <td>—</td> <td>0</td> <td>Analog speed setting</td> </tr> <tr> <td>ON</td> <td>—</td> <td>—</td> <td>1</td> <td>0</td> <td>Internal speed setting</td> </tr> <tr> <td>ON</td> <td>0</td> <td>0</td> <td>0</td> <td>0</td> <td>2-digit BCD</td> </tr> <tr> <td>ON</td> <td>0</td> <td>1</td> <td>0</td> <td>0</td> <td>Binary</td> </tr> <tr> <td>ON</td> <td>1</td> <td>0</td> <td>0</td> <td>0</td> <td>3-digit BCD</td> </tr> <tr> <td>ON</td> <td>1</td> <td>1</td> <td>0</td> <td>0</td> <td>Binary</td> </tr> </tbody> </table>																	ICN-5, 19	SELCD 1 (ξ_{0-25})				Speed Setting	DAS	Bit 3	Bit 2	Bit 1	Bit 0		OFF	—	—	—	0	Analog speed setting	ON	—	—	1	0	Internal speed setting	ON	0	0	0	0	2-digit BCD	ON	0	1	0	0	Binary	ON	1	0	0	0	3-digit BCD	ON	1	1	0	0	Binary
ICN-5, 19	SELCD 1 (ξ_{0-25})				Speed Setting																																																														
DAS	Bit 3	Bit 2	Bit 1	Bit 0																																																															
OFF	—	—	—	0	Analog speed setting																																																														
ON	—	—	1	0	Internal speed setting																																																														
ON	0	0	0	0	2-digit BCD																																																														
ON	0	1	0	0	Binary																																																														
ON	1	0	0	0	3-digit BCD																																																														
ON	1	1	0	0	Binary																																																														

Table 5.2 Speed Reference Input (Cont'd)

Signal	Connector No.	Pin No.	Function																																																																	
Digital Speed Input (D1 to D12)	2 CN	1 to 12	<p>For digital speed (binary BCD) and internal speed setting, forward and reverse run are selected by contact signal of FOR·REV from outside.</p> <ul style="list-style-type: none"> Internal speed setting Speed setting number : 8 steps Setting value : % setting for N 100 (rated speed) is input in [n-41 to 48 (0.00 to 100.00) <table border="1"> <thead> <tr> <th>Control Constants</th> <th>Symbol</th> <th>Internal Speed Setting</th> <th>2 CN Input</th> </tr> </thead> <tbody> <tr> <td>[n-41</td> <td>SPD 1</td> <td>1</td> <td>D 1</td> </tr> <tr> <td>[n-42</td> <td>SPD 2</td> <td>2</td> <td>D 2</td> </tr> <tr> <td>[n-43</td> <td>SPD 3</td> <td>3</td> <td>D 3</td> </tr> <tr> <td>[n-44</td> <td>SPD 4</td> <td>4</td> <td>D 4</td> </tr> <tr> <td>[n-45</td> <td>SPD 5</td> <td>5</td> <td>D 5</td> </tr> <tr> <td>[n-46</td> <td>SPD 6</td> <td>6</td> <td>D 6</td> </tr> <tr> <td>[n-47</td> <td>SPD 7</td> <td>7</td> <td>D 7</td> </tr> <tr> <td>[n-48</td> <td>SPD 8</td> <td>8</td> <td>D 8</td> </tr> </tbody> </table> <ul style="list-style-type: none"> When the plural speed selecting contacts turn ON simultaneously, lower speed setting No. is available. When all speed selecting contacts turn OFF, speed setting is 0. During operation setting constants ([n-41 to 48) cannot be selected. This function is not applicable to PROM for winding selection. 	Control Constants	Symbol	Internal Speed Setting	2 CN Input	[n-41	SPD 1	1	D 1	[n-42	SPD 2	2	D 2	[n-43	SPD 3	3	D 3	[n-44	SPD 4	4	D 4	[n-45	SPD 5	5	D 5	[n-46	SPD 6	6	D 6	[n-47	SPD 7	7	D 7	[n-48	SPD 8	8	D 8																													
		Control Constants	Symbol	Internal Speed Setting	2 CN Input																																																															
[n-41	SPD 1	1	D 1																																																																	
[n-42	SPD 2	2	D 2																																																																	
[n-43	SPD 3	3	D 3																																																																	
[n-44	SPD 4	4	D 4																																																																	
[n-45	SPD 5	5	D 5																																																																	
[n-46	SPD 6	6	D 6																																																																	
[n-47	SPD 7	7	D 7																																																																	
[n-48	SPD 8	8	D 8																																																																	
		1 to 12	<ul style="list-style-type: none"> 12-bit binary, 2-digit BCD or 3-digit BCD can be selected for the digital speed input (preset at the factory before delivery). External digital speed setting. <table border="1"> <thead> <tr> <th>Signal</th> <th>Pin No.</th> <th>12-bit Binary</th> <th>3-digit BCD</th> <th>2-digit BCD</th> </tr> </thead> <tbody> <tr> <td>D 1</td> <td>1</td> <td>1</td> <td>1</td> <td>—</td> </tr> <tr> <td>D 2</td> <td>2</td> <td>2</td> <td>2</td> <td>—</td> </tr> <tr> <td>D 3</td> <td>3</td> <td>4</td> <td>4</td> <td>—</td> </tr> <tr> <td>D 4</td> <td>4</td> <td>8</td> <td>8</td> <td>—</td> </tr> <tr> <td>D 5</td> <td>5</td> <td>16</td> <td>10</td> <td>1</td> </tr> <tr> <td>D 6</td> <td>6</td> <td>32</td> <td>20</td> <td>2</td> </tr> <tr> <td>D 7</td> <td>7</td> <td>64</td> <td>40</td> <td>4</td> </tr> <tr> <td>D 8</td> <td>8</td> <td>128</td> <td>80</td> <td>8</td> </tr> <tr> <td>D 9</td> <td>9</td> <td>256</td> <td>100</td> <td>10</td> </tr> <tr> <td>D 10</td> <td>10</td> <td>512</td> <td>200</td> <td>20</td> </tr> <tr> <td>D 11</td> <td>11</td> <td>1024</td> <td>400</td> <td>40</td> </tr> <tr> <td>D 12</td> <td>12</td> <td>2048</td> <td>800</td> <td>80</td> </tr> </tbody> </table> <ul style="list-style-type: none"> 12-bit Binary becomes the rated speed input when all signals are closed. 3-digit BCD becomes the rated speed input at 999. 2-digit BCD becomes the rated speed input at 99. 	Signal	Pin No.	12-bit Binary	3-digit BCD	2-digit BCD	D 1	1	1	1	—	D 2	2	2	2	—	D 3	3	4	4	—	D 4	4	8	8	—	D 5	5	16	10	1	D 6	6	32	20	2	D 7	7	64	40	4	D 8	8	128	80	8	D 9	9	256	100	10	D 10	10	512	200	20	D 11	11	1024	400	40	D 12	12	2048	800	80
Signal	Pin No.	12-bit Binary	3-digit BCD	2-digit BCD																																																																
D 1	1	1	1	—																																																																
D 2	2	2	2	—																																																																
D 3	3	4	4	—																																																																
D 4	4	8	8	—																																																																
D 5	5	16	10	1																																																																
D 6	6	32	20	2																																																																
D 7	7	64	40	4																																																																
D 8	8	128	80	8																																																																
D 9	9	256	100	10																																																																
D 10	10	512	200	20																																																																
D 11	11	1024	400	40																																																																
D 12	12	2048	800	80																																																																

5.2 SPEED REFERENCE (Cont'd)

Table 5.2 Speed Reference Input (Cont'd)

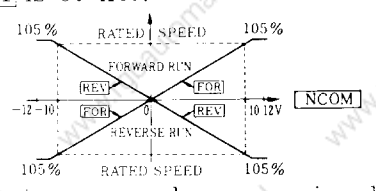
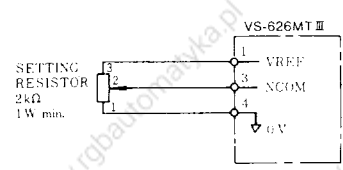
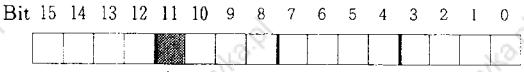
Signal	Connector No.	Pin No.	On Signal	Function
Base Block Signal CHW (Winding Selection Signal)	1CN	14	CLOSED	<ul style="list-style-type: none"> Base block signal activates by selecting 1 for bit 11 of SELCD1 (57-28).  <p>Bit 15 14 13 12 11 10 9 8 7 6 5 4 3 2 1 0</p> <p> → "0" : CHW (1CN-14) signal is unavailable → "1" : Baseblock at 1CN-14 "closed" (Motor coasting to a stop) </p> <p>This signal is originally used for winding selection. Therefore winding selection PROM is not used for base block.</p>

5.3 SEQUENCE OUTPUT SIGNAL

Use these output signals under the following conditions.

- For output signals, photo-couplers and reed relays are used. Capacity of reed relay is 24 VDC, 0.1 ADC and capacity of photo-couplers is 0.05 ADC.
- The contact chattering time is within 1 ms.
- To switch external relays or other inductive loads, be sure to connect a spark-killer in parallel to the load. Maximum allowable voltage of output circuit is 48 V.
- Where a capacitive load is to be controlled, connect a protective resistor in series to the load to limit current.
- Fig. 5.3 shows the output circuit, and Table 5.3 gives functions of the output signals.

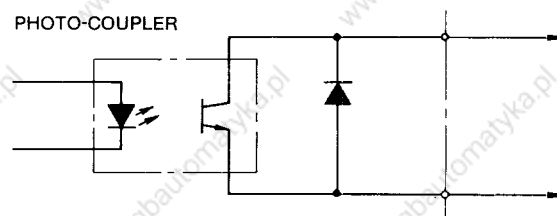

Note : The emitter terminals of the photo-coupler are all common. (1CN 41)

Fig. 5.3 Output Interface Circuit

The ON/OFF state of the output signal can be checked by the LED display on the setting panel (Use mode $\text{U}_n\text{-}00$). See Fig. 5.4 for the display.

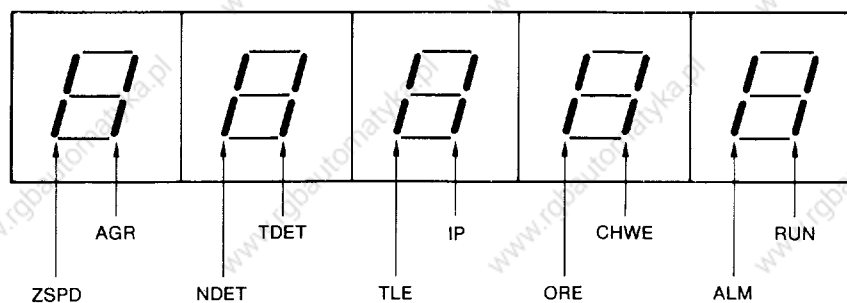

Fig. 5.4 Display of Output State

5.3 SEQUENCE OUTPUT SIGNAL (Cont'd)

Table 5.3 Functions of Sequence Output Signals



Signal	Connector No.	Contact and Pin No.	Function
Zero Speed Speed Z SPD	ICN	<p>Z SPD</p>  	<ul style="list-style-type: none"> When the motor speed drops below the set level (30 r/min), Z SPD closes. Once Z SPD is closed, it continues closed for 50 ms.  <ul style="list-style-type: none"> Since Z SPD is output irrespective of FOR and REV, it can be used as a safety run interlock signal. For Z SPD signal, photo-coupler output and contact output are used.
Speed Coincidence AGR	ICN		<ul style="list-style-type: none"> When the motor speed enters the preset range of NCOM, AGR closes. However, in baseblock status, it is not outputted. Once AGR is closed, it remains closed for 50 ms. When this signal is used as an answer to S command in NC program operation, the program is advanced to the next step. Speed coincidence signal setting range of $\pm 10\%$ to $\pm 50\%$ of rated speed is selected with speed coincidence range constants (α_0-39). 
Speed Detection N DET	ICN		<ul style="list-style-type: none"> When the motor speed drops below a preset level, N DET closes. The speed detection level is set between 0 and 100% speed with the preset constants (α_0-45 NDETL). Hysteresis width is set in (α_0-47). N DET operates regardless of the run direction signals. N DET can be used as the detection signal for the speed suitable for clutch actuation or gear shifting. 
Torque Detection T DET	ICN		<ul style="list-style-type: none"> When torque decreases below a specified level, T DET closes. The torque detection level can be set between 5 and 120% of 30-minute rating with the control constants (α_0-48 TDET). T DET can be used as a signal for checking the torque limit function, and for determining the load conditions.
Torque Limit TLE			<ul style="list-style-type: none"> When external torque limit TLL or TLH is input, TLE will be closed. TLE can be used as check signal for TLL and TLH.

Table 5.3 Functions of Sequence Output Signals (Cont'd)

Signal	Connector No.	Contact and Pin No.	Function																																																																																																																										
Alarm [ALM]	1 CN		<ul style="list-style-type: none"> When protective circuit for overcurrent or overload tripped, the motor current is instantly interrupted, and the motor stops after running by inertia. Upon current interruption, [ALM] is output. The [ALM] relay is normally-open mode. The contact is "C" type. While [ALM] is output, the motor cannot run. When [ALM] is used to reset [NCOM], [FOR] or [REV], displays a spindle alarm visual signal. [ALM] is displayed on the setting panel. For these, refer to the alarm code shown below. For the relationship between [ALM] and [RST], refer to Item "Alarm Reset" in Table 5.1. 																																																																																																																										
Spindle One Rotation Signal [IP]	1 CN		<ul style="list-style-type: none"> This signal is only for the unit with magnetic type orientation card (JPAC-C 345 and FS-1378 type). During the [ORT] input, [IP] is closed by sensor signal. The signal may not be output at a spindle speed of 300 r/min or above. 																																																																																																																										
Alarm Code [AC 1] [AC 2] [AC 4] [AC 8]	1 CN		<ul style="list-style-type: none"> The contents of the alarm is output by the alarm code signal. The contents of the alarm codes are as below. <table border="1"> <thead> <tr> <th>No.</th> <th>LED Display</th> <th>Code</th> <th>Name</th> <th>Alarm Code AC3AC2AC1AC0</th> </tr> </thead> <tbody> <tr> <td>1</td> <td>ESP</td> <td>EMGSTP</td> <td>Emergency stop error</td> <td>1 1 1 1</td> </tr> <tr> <td>2</td> <td>IDC</td> <td>OC</td> <td>Overcurrent</td> <td>1 1 1 0</td> </tr> <tr> <td>3</td> <td>MCC</td> <td>MCCB</td> <td>MCCB trip</td> <td>1 1 0 1</td> </tr> <tr> <td>4</td> <td>COC</td> <td>RGOC</td> <td>Regenerative overcurrent</td> <td>1 1 0 0</td> </tr> <tr> <td>5</td> <td>OU</td> <td>OV</td> <td>Overvoltage</td> <td>1 0 1 1</td> </tr> <tr> <td>6</td> <td>OS</td> <td>OS</td> <td>Overspeed</td> <td>1 0 1 0</td> </tr> <tr> <td>7</td> <td>UU</td> <td>UV</td> <td>Undervoltage</td> <td>1 0 0 1</td> </tr> <tr> <td>8</td> <td>OL</td> <td>OL</td> <td>Overload</td> <td>1 0 0 0</td> </tr> <tr> <td>9</td> <td>DEU</td> <td>DEV</td> <td>Excessive speed deviation</td> <td>0 1 1 1</td> </tr> <tr> <td>10</td> <td>OH</td> <td>MOH</td> <td>Motor overheat</td> <td></td> </tr> <tr> <td>11</td> <td>OHL</td> <td>THMSTA</td> <td>Thermo detector disconnection</td> <td>0 1 1 0</td> </tr> <tr> <td>12</td> <td>OHF</td> <td>FOH</td> <td>Controller overheat</td> <td></td> </tr> <tr> <td rowspan="2">13</td> <td rowspan="2">FU</td> <td>DCFU</td> <td>DC circuit fuse blown</td> <td rowspan="2">0 1 0 1</td> </tr> <tr> <td>ISO AMP</td> <td>Isolation amplifier defective</td> </tr> <tr> <td>14</td> <td>Ad</td> <td>AD</td> <td>16-bit AD defective</td> <td>0 1 0 0</td> </tr> <tr> <td>15</td> <td>AdC</td> <td>CPU-AD</td> <td>CPU AD defective</td> <td></td> </tr> <tr> <td>16</td> <td>PG</td> <td>PG</td> <td>PG disconnection</td> <td></td> </tr> <tr> <td>17</td> <td>PCC</td> <td>PGC</td> <td>PG counter defective</td> <td>0 0 1 1</td> </tr> <tr> <td>18</td> <td>ICP</td> <td>ROM</td> <td>PROM error</td> <td>0 0 1 0</td> </tr> <tr> <td>19</td> <td>ICAI</td> <td>RAM-I</td> <td>Internal RAM error</td> <td></td> </tr> <tr> <td>20</td> <td>ICRE</td> <td>RAM-E</td> <td>External RAM error</td> <td>0 0 0 1</td> </tr> <tr> <td>21</td> <td>ICAN</td> <td>RAM-N</td> <td>NV-RAM error</td> <td></td> </tr> <tr> <td>22</td> <td>•••••</td> <td>CPF</td> <td>Controller function defective</td> <td>0 0 0 0</td> </tr> <tr> <td>23</td> <td>CHE</td> <td>CHE</td> <td>Winding selection error</td> <td>1 1 1 1</td> </tr> </tbody> </table>	No.	LED Display	Code	Name	Alarm Code AC3AC2AC1AC0	1	ESP	EMGSTP	Emergency stop error	1 1 1 1	2	IDC	OC	Overcurrent	1 1 1 0	3	MCC	MCCB	MCCB trip	1 1 0 1	4	COC	RGOC	Regenerative overcurrent	1 1 0 0	5	OU	OV	Overvoltage	1 0 1 1	6	OS	OS	Overspeed	1 0 1 0	7	UU	UV	Undervoltage	1 0 0 1	8	OL	OL	Overload	1 0 0 0	9	DEU	DEV	Excessive speed deviation	0 1 1 1	10	OH	MOH	Motor overheat		11	OHL	THMSTA	Thermo detector disconnection	0 1 1 0	12	OHF	FOH	Controller overheat		13	FU	DCFU	DC circuit fuse blown	0 1 0 1	ISO AMP	Isolation amplifier defective	14	Ad	AD	16-bit AD defective	0 1 0 0	15	AdC	CPU-AD	CPU AD defective		16	PG	PG	PG disconnection		17	PCC	PGC	PG counter defective	0 0 1 1	18	ICP	ROM	PROM error	0 0 1 0	19	ICAI	RAM-I	Internal RAM error		20	ICRE	RAM-E	External RAM error	0 0 0 1	21	ICAN	RAM-N	NV-RAM error		22	•••••	CPF	Controller function defective	0 0 0 0	23	CHE	CHE	Winding selection error	1 1 1 1
No.	LED Display	Code	Name	Alarm Code AC3AC2AC1AC0																																																																																																																									
1	ESP	EMGSTP	Emergency stop error	1 1 1 1																																																																																																																									
2	IDC	OC	Overcurrent	1 1 1 0																																																																																																																									
3	MCC	MCCB	MCCB trip	1 1 0 1																																																																																																																									
4	COC	RGOC	Regenerative overcurrent	1 1 0 0																																																																																																																									
5	OU	OV	Overvoltage	1 0 1 1																																																																																																																									
6	OS	OS	Overspeed	1 0 1 0																																																																																																																									
7	UU	UV	Undervoltage	1 0 0 1																																																																																																																									
8	OL	OL	Overload	1 0 0 0																																																																																																																									
9	DEU	DEV	Excessive speed deviation	0 1 1 1																																																																																																																									
10	OH	MOH	Motor overheat																																																																																																																										
11	OHL	THMSTA	Thermo detector disconnection	0 1 1 0																																																																																																																									
12	OHF	FOH	Controller overheat																																																																																																																										
13	FU	DCFU	DC circuit fuse blown	0 1 0 1																																																																																																																									
		ISO AMP	Isolation amplifier defective																																																																																																																										
14	Ad	AD	16-bit AD defective	0 1 0 0																																																																																																																									
15	AdC	CPU-AD	CPU AD defective																																																																																																																										
16	PG	PG	PG disconnection																																																																																																																										
17	PCC	PGC	PG counter defective	0 0 1 1																																																																																																																									
18	ICP	ROM	PROM error	0 0 1 0																																																																																																																									
19	ICAI	RAM-I	Internal RAM error																																																																																																																										
20	ICRE	RAM-E	External RAM error	0 0 0 1																																																																																																																									
21	ICAN	RAM-N	NV-RAM error																																																																																																																										
22	•••••	CPF	Controller function defective	0 0 0 0																																																																																																																									
23	CHE	CHE	Winding selection error	1 1 1 1																																																																																																																									

In addition, there is an orientation completion signal as a sequence output signal. For details, See "Magnetic Sensor Type Spindle Orientation" on page 83.

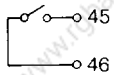
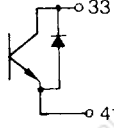
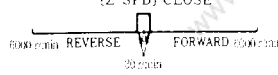
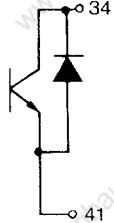
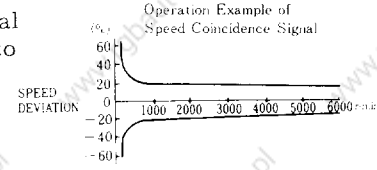
5. 4 OPTICAL ENCODER (PG) PULSE OUTPUT CIRCUIT [PCA, * PCA, PCB, * PCB, PCC, * PCC] * Reverse signals

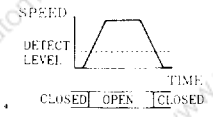
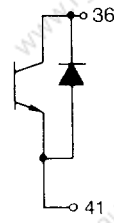
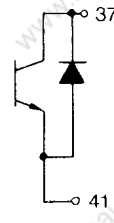
Phases A, B, and C(original point) signals for the optical encoder, PG(1024 pulses/rev) are output.

Use these signals as the positioning signals. The output signal specifications are as follows:

(1) Signal form

- Two-phase pulse with 90° pulse difference (phase A and B)
- Original point pulse(phase C)

(2) Output circuit and receiver circuit

Line driver output is provided as output circuit. Fig. 5.5 shows the connecting example of output circuit and receiver circuit.

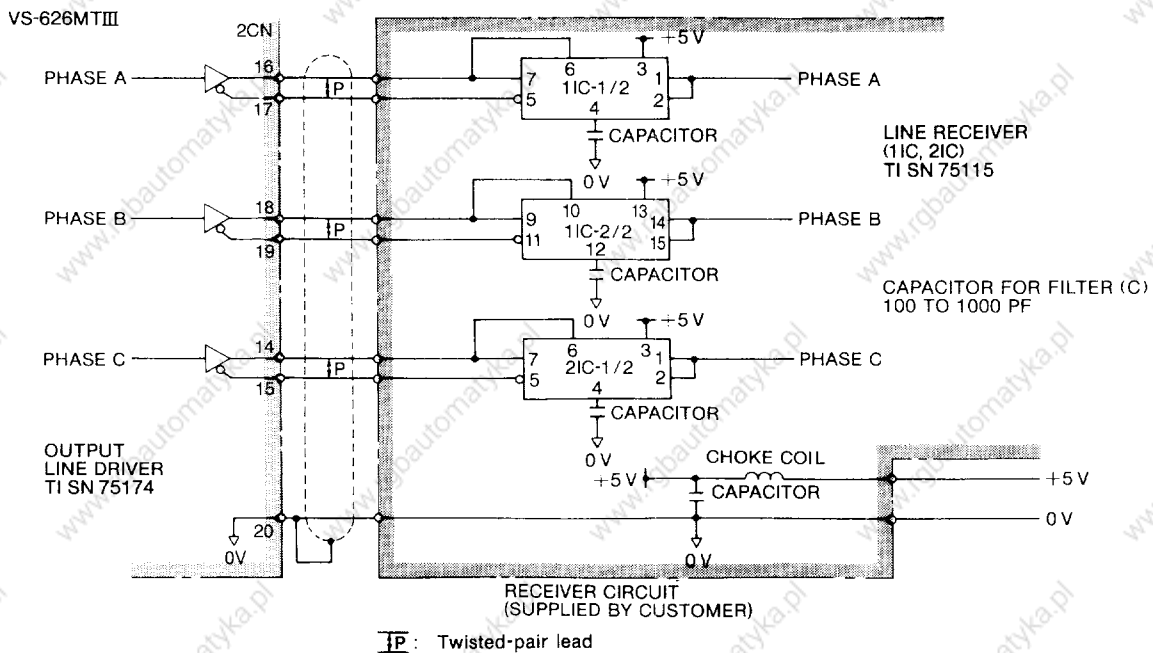

Fig. 5.5 Output Circuit and Receiver Circuit

(3) Output phase

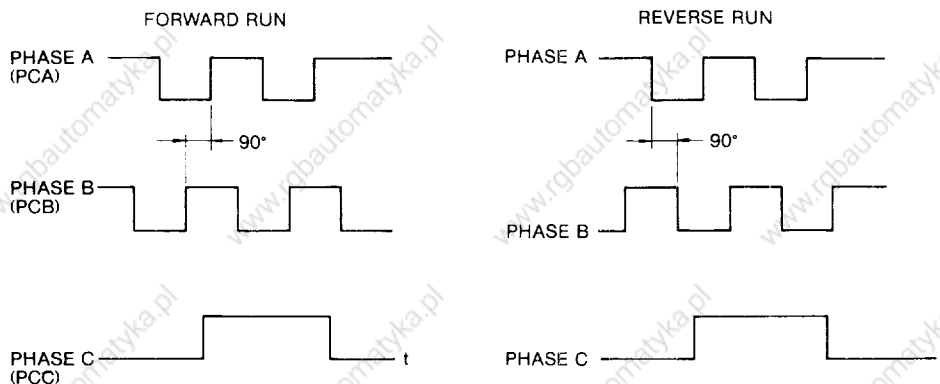

Fig. 5.6 Output Phase

5. 5 ANALOG OUTPUT SIGNAL

Use the analog output signals in the following conditions.

Table 5. 4 Function of Analog Output Signal

Signal	Connector No.	Pin No.	Function												
Speed-ometer SM	1CN or Screw Terminal No.1	47	<ul style="list-style-type: none"> When an external speedometer is connected, the motor speed can be monitored. Speedometer signal terminal outputs DC voltage signal proportional to the motor speed, regardless of the run direction. Select a voltmeter as a speedometer which satisfies the following specifications. <table border="1"> <thead> <tr> <th>Item</th> <th>Specifications</th> </tr> </thead> <tbody> <tr> <td>Speedometer</td> <td>Voltmeter</td> </tr> <tr> <td>Activation</td> <td>Moving coil type</td> </tr> <tr> <td>Rating</td> <td>10 V full-scale</td> </tr> <tr> <td>Internal Resistance</td> <td>10 kΩ</td> </tr> <tr> <td>Class</td> <td>2.5 class or above</td> </tr> </tbody> </table> <ul style="list-style-type: none"> The level of speedometer signal is adjustable with the control constant (C_{n-06} SMADJ). Since SMADJ is only for adjusting the speedometer, the actual speed is not influenced by it. The forward and reverse run speed accuracy is $\pm 2\%$ max. of the rated speed. 	Item	Specifications	Speedometer	Voltmeter	Activation	Moving coil type	Rating	10 V full-scale	Internal Resistance	10 k Ω	Class	2.5 class or above
Item	Specifications														
Speedometer	Voltmeter														
Activation	Moving coil type														
Rating	10 V full-scale														
Internal Resistance	10 k Ω														
Class	2.5 class or above														
Load Meter Signal LM	1CN or Screw Terminal No. 2	50	<ul style="list-style-type: none"> The load meter indicates the percentage of the actual load to the rated output of the motor. Select a load meter conforming to the same specifications as the speedometer. Load meter signal can be adjusted with the control constants (C_{n-07} LMADJ and C_{n-08} LMFS). 												

Note: For the meter 0V, use pin Nos. 48 and 49 of 1CN or screw terminal No.3.

6. DIMENSIONS AND INSTALLATION

6.1 AC SPINDLE MOTOR DIMENSIONS in mm (in inches)

● FOOT-MOUNTED TYPE

● FLANGE-MOUNTED TYPE

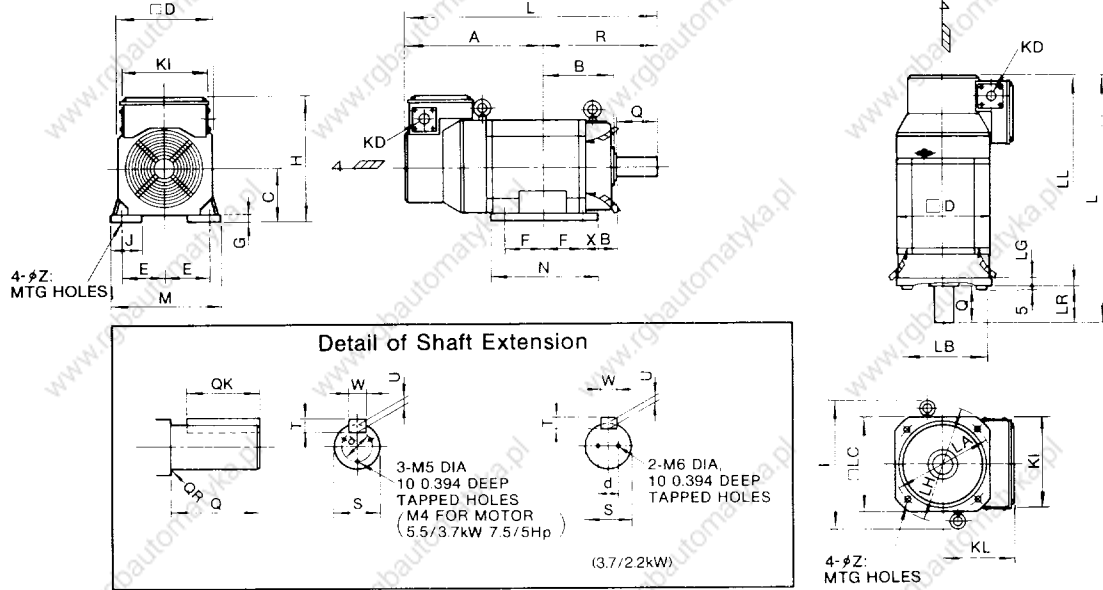

FOOT-MOUNTED TYPE

	Rated Output ^{kW} / _{HP}		A	B	C ⁰ / _{0.5}	D	E	F	G	H	J	KD	L	M	N	R	XB	Z	KI	Shaft Extension							
	30-min Rating	Continuous Rating																		Q	QK	QR	S	T	U	W	d
Standard	3.7 (5)	2.2* (3)	251 (9.88)	93 (3.66)	100 (3.94)	174 (6.85)	80 (3.15)	50 (1.97)	9 (0.35)	241 (9.49)	34 (1.34)	34 (1.34)	406 (15.98)	188 (7.40)	125 (4.92)	155 (6.10)	45 (1.77)	12 (0.47)	174 (6.85)	60 (2.36)	45 (1.77)	1 (0.04)	28 (1.1024)	7 (0.28)	4 (0.16)	8 (0.31)	16 (0.63)
	5.5 (7.5)	3.7 (5)	262 (10.31)	117 (4.61)	112 (4.41)	204 (8.03)	95 (3.74)	50 (1.97)	10 (0.39)	267 (10.51)	75 (2.95)	42.5 (1.67)	442 (17.40)	220 (8.66)	129 (5.08)	180 (7.09)	70 (2.76)	12 (0.47)	204 (8.03)	60 (2.36)	45 (1.77)	1 (0.04)	28 (1.1024)	7 (0.28)	4 (0.16)	8 (0.31)	16 (0.63)
	7.5 (10)	5.5 (7.5)	290 (11.42)	137 (5.39)	112 (4.41)	204 (8.03)	95 (3.74)	70 (2.76)	10 (0.39)	267 (10.51)	75 (2.95)	42.5 (1.67)	510 (20.08)	220 (8.66)	177 (6.97)	220 (8.66)	70 (2.76)	12 (0.47)	204 (8.03)	60 (2.36)	45 (1.77)	1 (0.04)	32 (1.2598)	8 (0.31)	5 (0.20)	10 (0.39)	22 (0.87)
	11 (15)	7.5 (10)	230 (9.06)	176 (6.93)	160 (6.30)	250 (9.84)	127 (5.00)	70 (2.76)	16 (0.63)	340 (13.39)	50 (1.97)	42.5 (1.67)	518 (20.39)	290 (11.42)	206 (8.11)	288 (11.34)	108 (4.25)	15 (0.59)	250 (9.84)	110 (4.33)	90 (3.54)	0 (0.02)	48 (1.8898)	9 (0.35)	5.5 (0.22)	14 (0.55)	40 (1.57)
	15 (20)	11 (15)	249 (9.80)	195 (7.68)	160 (6.30)	250 (9.84)	127 (5.00)	89 (3.50)	16 (0.63)	340 (13.39)	50 (1.97)	42.5 (1.67)	556 (21.89)	290 (11.42)	244 (9.61)	307 (12.09)	108 (4.25)	15 (0.59)	250 (9.84)	110 (4.33)	90 (3.54)	0 (0.02)	48 (1.8898)	9 (0.35)	5.5 (0.22)	14 (0.55)	40 (1.57)
	18.5 (25)	15 (20)	304 (11.97)	211 (8.31)	160 (6.30)	250 (9.84)	127 (5.00)	105 (4.13)	16 (0.63)	360 (14.17)	55 (2.17)	42.5 (1.67)	627 (24.69)	290 (11.42)	278 (10.94)	323 (12.72)	108 (4.25)	15 (0.59)	250 (9.84)	110 (4.33)	90 (3.54)	0 (0.02)	48 (1.8898)	9 (0.35)	5.5 (0.22)	14 (0.55)	40 (1.57)
	22 (30)	18.5 (25)	318 (12.52)	233 (9.17)	160 (6.30)	250 (9.84)	127 (5.00)	127 (5.00)	16 (0.63)	360 (14.17)	55 (2.17)	42.5 (1.67)	663 (26.10)	290 (11.42)	320 (12.60)	345 (13.58)	108 (4.25)	15 (0.59)	250 (9.84)	110 (4.33)	90 (3.54)	0 (0.02)	55 (2.1654)	10 (0.39)	6 (0.24)	16 (0.63)	45 (1.77)
	30 (40)	22 (30)	455 (17.91)	246 (9.69)	180 (7.09)	310 (12.20)	139.5 (5.49)	127 (5.00)	16 (0.63)	432 (17.22)	55 (2.17)	42.5 (1.67)	843 (33.19)	320 (12.60)	350 (13.78)	388 (15.28)	121 (4.76)	19 (0.75)	310 (12.20)	140 (5.51)	110 (4.33)	0 (0.02)	60 (2.3622)	11 (0.43)	7 (0.28)	18 (0.71)	50 (1.97)

* 15-minute rating (50% ED) /continuous rating. Not furnished with eyebolts for 3.7/2.2 kW unit.

FLANGE-MOUNTED TYPE

	Rated Output ^{kW} / _{HP}		L	LA	LB	LC	LG	LH	LL	LR	Z	D	I	KD	KL	KI	Shaft Extension							
	30-min Rating	Continuous Rating															Q	QK	QR	S	T	U	W	d
Standard	3.7 (5)	2.2 (3)	424 (16.70)	183 (7.28)	150 (5.9055)	174 (6.85)	15 (0.59)	220 (8.66)	364 (14.33)	60 (2.36)	11 (0.43)	174 (6.85)	134 (5.28)	141 (5.55)	174 (6.85)	60 (2.36)	45 (1.77)	1 (0.04)	28 (1.1024)	7 (0.28)	4 (0.16)	8 (0.31)	16 (0.63)	
	5.5 (7.5)	3.7 (5)	459 (18.07)	215 (8.46)	180 (7.0866)	204 (8.03)	17 (0.67)	250 (9.84)	399 (15.41)	60 (2.36)	15 (0.59)	204 (8.03)	270 (10.63)	204 (8.03)	155 (6.10)	204 (8.03)	60 (2.36)	45 (1.77)	1 (0.04)	28 (1.1024)	7 (0.28)	4 (0.16)	8 (0.31)	16 (0.63)
	7.5 (10)	5.5 (7.5)	527 (20.75)	215 (8.46)	180 (7.0866)	204 (8.03)	17 (0.67)	250 (9.84)	447 (17.60)	80 (3.15)	15 (0.59)	204 (8.03)	270 (10.63)	204 (8.03)	155 (6.10)	204 (8.03)	60 (2.36)	45 (1.77)	1 (0.04)	32 (1.2598)	8 (0.31)	5 (0.20)	10 (0.39)	22 (0.87)
	11 (15)	7.5 (10)	514 (20.24)	265 (10.43)	230 (9.0551)	250 (9.84)	18 (0.71)	300 (11.81)	404 (15.91)	110 (4.33)	15 (0.59)	250 (9.84)	335 (13.19)	250 (9.84)	180 (7.09)	250 (9.84)	110 (4.33)	90 (3.54)	0 (0.02)	48 (1.8898)	9 (0.35)	5.5 (0.22)	14 (0.55)	40 (1.57)
	15 (20)	11 (15)	552 (21.73)	265 (10.43)	230 (9.0551)	250 (9.84)	18 (0.71)	300 (11.81)	442 (17.40)	110 (4.33)	15 (0.59)	250 (9.84)	335 (13.19)	250 (9.84)	180 (7.09)	250 (9.84)	110 (4.33)	90 (3.54)	0 (0.02)	48 (1.8898)	9 (0.35)	5.5 (0.22)	14 (0.55)	40 (1.57)
	18.5 (25)	15 (20)	626 (24.65)	265 (10.43)	230 (9.0551)	250 (9.84)	18 (0.71)	300 (11.81)	516 (20.31)	110 (4.33)	15 (0.59)	250 (9.84)	335 (13.19)	200 (7.87)	250 (9.84)	110 (4.33)	90 (3.54)	0 (0.02)	48 (1.8898)	9 (0.35)	5.5 (0.22)	14 (0.55)	40 (1.57)	
	22 (30)	18.5 (25)	674 (26.34)	265 (10.43)	230 (9.0551)	250 (9.84)	20 (0.79)	300 (11.81)	564 (22.20)	110 (4.33)	15 (0.59)	250 (9.84)	335 (13.19)	200 (7.87)	250 (9.84)	110 (4.33)	90 (3.54)	0 (0.02)	55 (2.1654)	10 (0.39)	6 (0.24)	16 (0.63)	45 (1.77)	
	30 (40)	22 (30)	886 (34.88)	350 (13.78)	300 (11.8110)	320 (12.60)	20 (0.79)	385 (15.16)	746 (29.37)	140 (5.51)	19 (0.75)	310 (12.20)	432 (17.00)	252 (9.92)	310 (12.20)	140 (5.51)	110 (4.33)	0 (0.02)	60 (2.3622)	11 (0.43)	7 (0.28)	18 (0.71)	50 (1.97)	

* 15-minute rating (50% ED) /continuous rating. Not furnished with eyebolts for 3.7/2.2 kW unit.

6.2 VS-626MT^{III} CONTROLLER DIMENSIONS in mm (in inches)

● TOTALLY-ENCLOSED TYPE

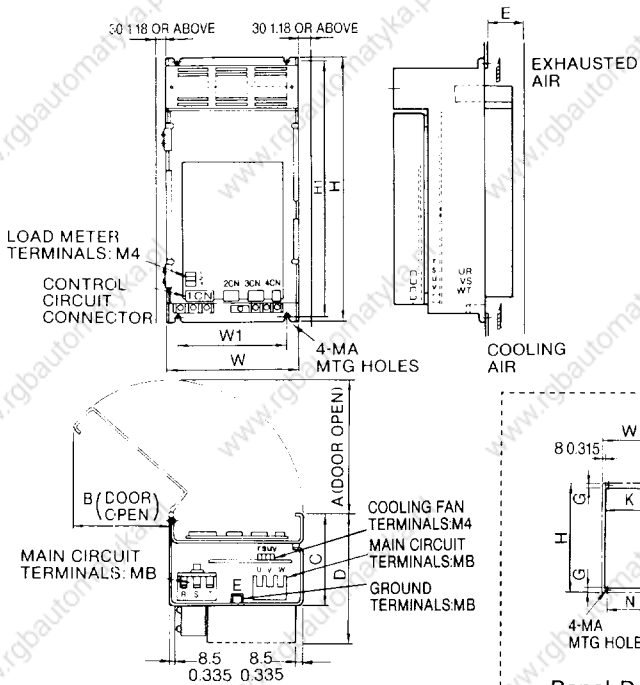

● OPEN CHASSIS TYPE

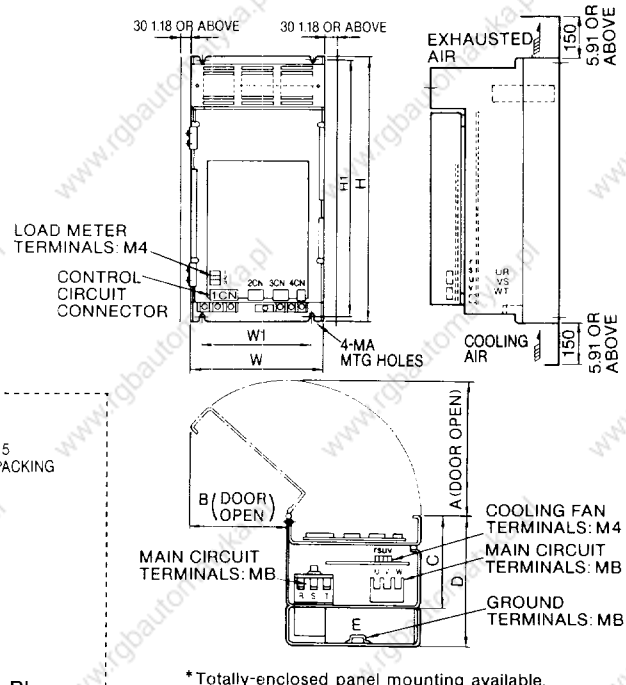

*Totally-enclosed panel mounting available.

Model CIMR-MT ^{III} -	Construction	W	H	D	W1	H1	A	B	C	E	G	I	J	K	N	MA	MB
3.7K 5.5K	Totally-enclosed	250	470	268 (10.55)	200	455	251	192	204	70 to 75 (2.76 to 2.95)	15 (0.59)	455 (17.91)	440 (17.32)	234 (9.21)	200 (7.87)	M6	M5
	Open chassis			270 (10.63)						—	—	—	—	—			
7.5K	Totally-enclosed	(9.84)	(18.50)	287 (11.30)	(7.87)	(17.91)	(9.88)	(7.56)	(8.03)	85 to 90 (3.35 to 3.54)	15 (0.59)	455 (17.91)	440 (17.32)	234 (9.21)	200 (7.87)	M6	M5
	Open chassis	—	—	289 (11.38)	—	—	—	—	—	—	—	—	—	—	—		
11K	Totally-enclosed	300	600	288 (11.34)	250	580	300	228	207	85 to 90 (3.35 to 3.54)	20 (0.79)	580 (22.83)	560 (22.05)	284 (11.18)	250 (9.84)	M8	M8
	Open chassis			—						—	290 (11.42)	—	—	—	—		
15K	Totally-enclosed	(11.81)	640 (25.20)	288 (11.34)	(9.84)	620 (24.41)	(11.81)	(8.98)	(8.15)	85 to 90 (3.35 to 3.54)	20 (0.79)	620 (24.41)	600 (23.62)	284 (11.18)	250 (9.84)	M8	M8
	Open chassis	—	—	290 (11.42)	—	—	—	—	—	—	—	—	—	—	—		
18.5K 22K	Totally-enclosed	300	850 (33.46)	292 (11.50)	250	830 (32.68)	310 (12.20)	228 (8.98)	207 (8.15)	90 to 95 (3.54 to 3.74)	20 (0.79)	830 (32.68)	810 (31.89)	284 (11.18)	250 (9.84)	M8	M8
	Open chassis			—						—	294 (11.57)	—	—	—	—		
30K	Totally-enclosed	420 (16.54)	850 (33.46)	294 (11.57)	380 (14.96)	830 (32.68)	410 (16.14)	240 (9.45)	224 (8.82)	105 to 110 (4.13 to 4.33)	25 (0.98)	830 (32.68)	800 (31.50)	400 (15.75)	380 (14.96)	M8	M8
	Open chassis			—						—	331 (13.03)	—	—	—	—		

6.3 INSTALLATION

6.3.1 Installing Spindle AC Motor

(1) Location

- See that air flow through the cooling fan is completely free from obstruction. Maintain a minimum of 100 mm from the near of motor.
- See that the motor is free from direct splashing of cutting oil from the machine tool.
- Mounting base, bed or frame must be solid and rigid enough to sustain the motor or its dynamic load during operation so as to minimize vibration.

(2) Mounting

- The spindle motor permits mountings at any angle from horizontal to drive-end-down.

(3) Connection with machine

- For V-belt drive, the shafts of the motor and driven machine are parallel to each other, and align the sheaves.
- For a gear drive, install the motor with the shaft paralleled with the machine spindle, and the gear meshing centrally.
- Since AC spindle motor is rotated at a high-speed, even a small imbalance will cause vibration. The rotor is dynamically balanced with half-keys with a thickness 1/2 the key size indicated in the dimension drawing (shaft). Special care must be taken of the gear, pulley, etc. when designing machine tools.

6.3.2 Installing Controller

To install the VS-626MTIII controller in a power control panel or the like, take the following into consideration.

(1) Heat dissipation

- Incorporate heat dissipating features into the design, in due consideration of the heat generating rate.
- For the heat generation rates of the different types, refer to Table 1.1, Standard Specifications.
- Maintain the operating temperature of the controller between 0 to + 55°C.
- To maintain the cooling performance of the controllers, be sure to secure at least 100 mm above (discharge side) and 50 mm below (suction side) spaces the controller respectively.

(2) Maintenance

- In designing the panel housing, take the convenience of maintenance work into consideration. Be sure to allow sufficient space to fully open the front panel.
- For mounting and replacing the controller, secure at least 30 mm space on both the right and left sides between controller and the side walls.
- The I/O terminals and the control signal connectors are located at the lowermost part of the controller. Be sure to allow space below the controller so that cables can be easily connected to the terminals and connectors.

Fig. 6.1 shows the mounting space.

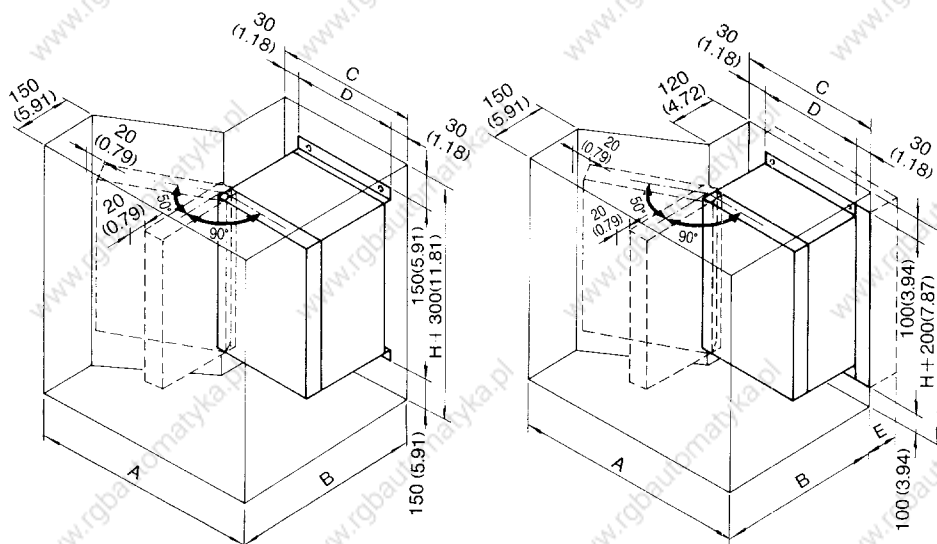

(a) Open Chassis Type

(b) Totally-enclosed Type

Note:

1. Be sure to provide the rear panel of the controller with a cooling air flow space.
2. The cooling air velocity must be 3 m/s in air duct.
3. Insert packings under the units when installing them to avoid clearance.

Dimensions in mm (in inches)

Type CIMR-MTIII-	Enclosure	A	B	C	D	E
3.7 K, 5.5 K	Open chassis Type	550 (21.65)	535 (21.06)	310 (12.20)	250 (9.84)	—
	Totally-enclosed Type		470 (18.50)			70 to 75 (2.76 to 2.95)
7.5 K	Open chassis Type	550 (21.65)	555 (21.85)	310 (12.20)	250 (9.84)	—
	Totally-enclosed Type		470 (18.50)			85 to 90 (3.35 to 3.54)
11 K 15 K	Open chassis Type	600 (23.62)	584 (22.99)	360 (14.17)	300 (11.81)	—
	Totally-enclosed Type		500 (19.69)			85 to 90 (3.35 to 3.54)
18.5 K 22 K	Open chassis Type	600 (23.62)	588 (23.15)	360 (14.17)	300 (11.81)	—
	Totally-enclosed Type		500 (19.69)			90 to 95 (3.54 to 3.74)
30 K	Open chassis Type	786 (30.94)	755 (29.72)	480 (18.90)	420 (16.54)	—
	Totally-enclosed Type		650 (25.60)			105 to 110 (4.13 to 4.33)

7. CONFIGURATION

7.1 CONSTRUCTION OF VS-626MT^{III} CONTROLLER

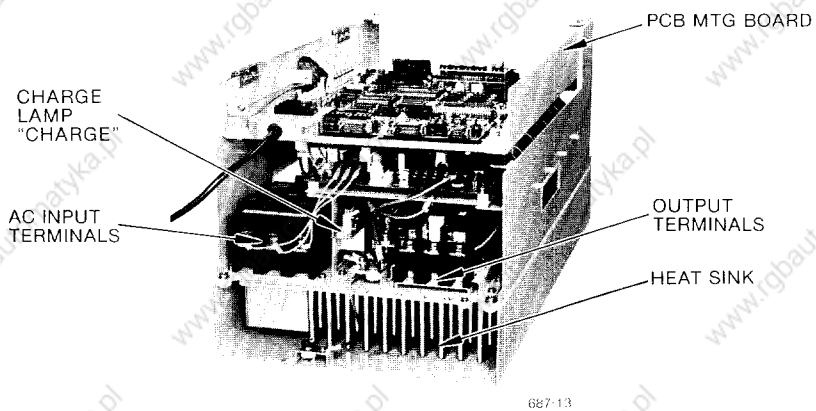
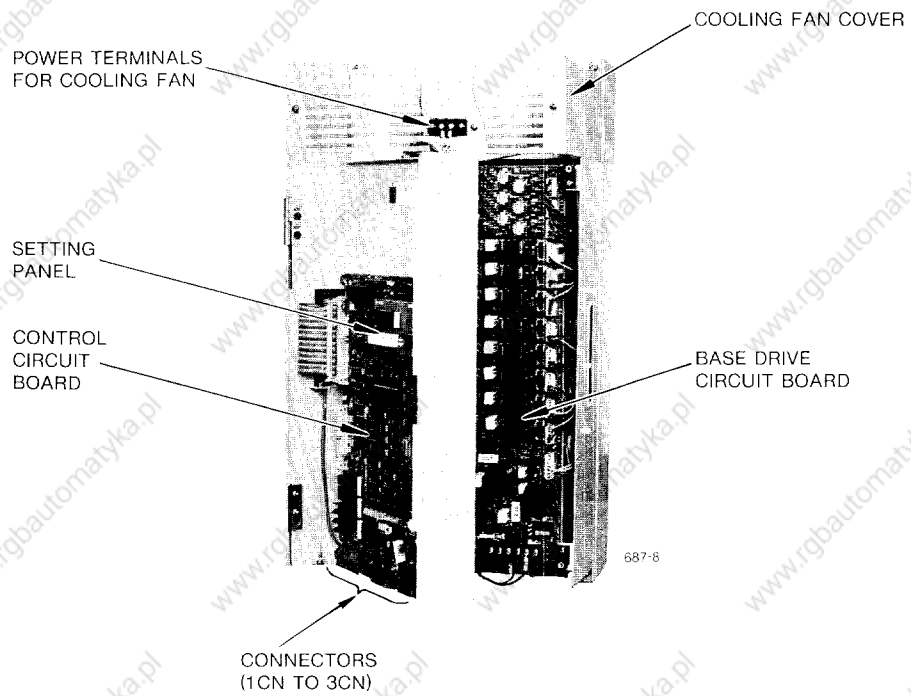
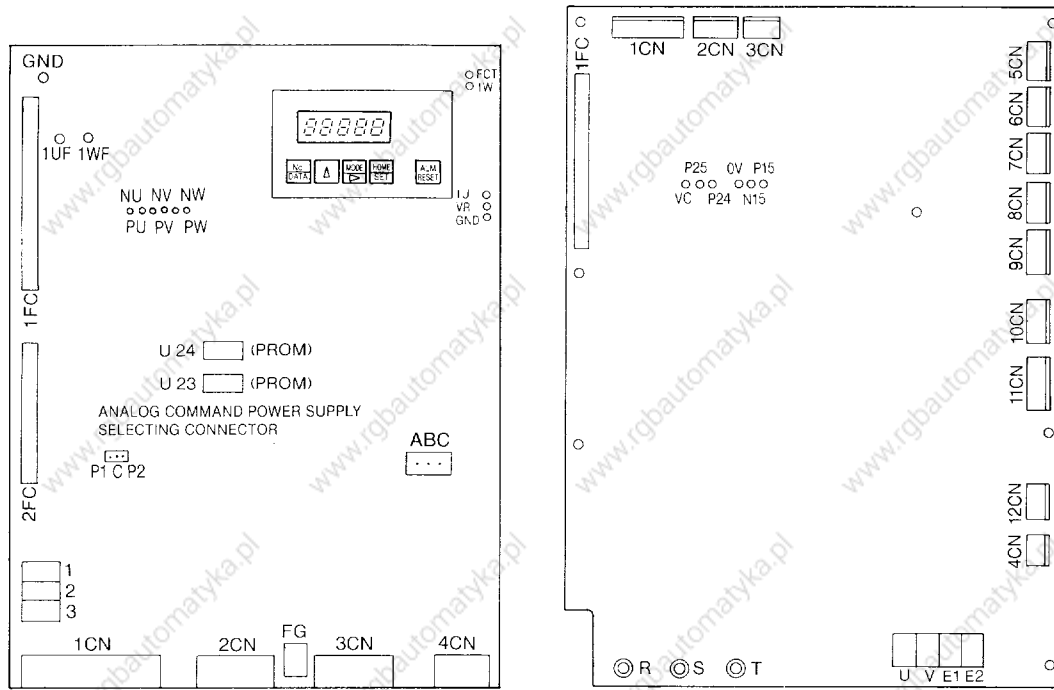

Fig. 7.1 Construction of VS-626MT^{III} Controller
Type CIMR-MT^{III}-11K

7.2 PRINTED CIRCUIT BOARD LAYOUT



(a) CIMR-MTIII Models -3.7K, -5.5K and -7.5K

Fig. 7.2 Controller Layout

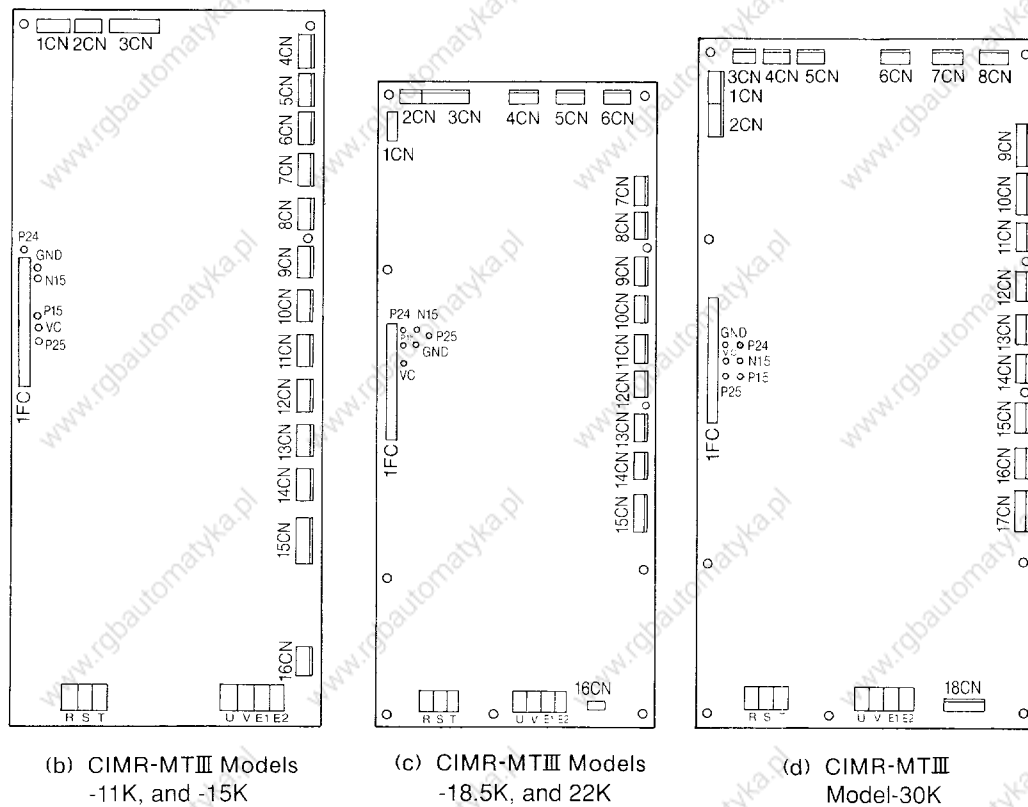

(b) CIMR-MTIII Models -11K, and -15K

(c) CIMR-MTIII Models -18.5K, and 22K

(d) CIMR-MTIII Model-30K

Fig. 7.3 Base Driver Layout

8. PREPARATION FOR OPERATION

8.1 CHECKS BEFORE TEST RUN

After completing mounting and connection of units, check for:

- Correct connections. Never use control circuit buzzer check.
- No loose screw terminals. (Input/output terminals, fuses, parts in main circuits)
- Connectors are firmly connected to proper terminals, etc.
- No short-circuit conditions
- Operable condition of the motor, spindle and machines.

8.2 CHECKING POWER UNIT AND PRINTED CIRCUIT BOARDS

Check for appropriate types of the power unit and printed circuit boards in accordance with Table 8.1. If the type is incorrect, the specifications cannot be met. In this case, contact your Yaskawa representative.

Table 8.1 Models of Power Unit and Printed Circuit Board

Name	Model						
Power Unit*	CIMR-MTIII-□□						
	3.7K (3.7kW, 5HP)	5.5K (5.5kW, 7.5HP)	7.5K (7.5kW, 10HP)	11K (11kW, 15HP)	15K (15kW, 20HP)	18.5K (18.5kW, 25HP)	22K (22kW, 30HP)
Control Circuit Board	JPAC-C341			JPAC-C341-A	JPAC-C341	JPAC-C341-A	
Base Drive Circuit Board	JPAC-C342		JPAC-C343		JPAC-C371		JPAC-C372

*Parenthesis shows motor capacity for 30-minute operation rating.

8.3 CHECKING POTENTIOMETER SETTING

The potentiometers have been adjusted to appropriate level at the factory. The potentiometers are paint-locked. Be sure that the lock positions are not slided from the paint.

8.4 CHECKING POWER SUPPLY VOLTAGE

Confirm that the input power supply voltage is within the allowable range shown in Table 8.2.

Table 8.2 Allowable Range of Power Supply Voltage

Rated Voltage V	Frequency Hz	Allowable Range V
200	50 / 60	170 – 220
220	50 / 60	187 – 242
230	60	195 – 253

Note: Spindle drive system can normally operate within a range of 170 to 253V and has been set in such a manner that the optimum characteristics can be obtained between 200 and 240V. Therefore, if the input voltage can be changed by switching the transformer taps, operation with the most desirable characteristics can be obtained by setting the input voltage within the 200 to 240V range.

8.5 CHECKING SPEED COMMAND INPUT SELECTION

Shunt connectors are selected by speed command input as shown in Table 8.3. For analog command input, see Fig. 7.3 for the location of analog command power supply selector.

Table 8.3 Shunt Connector Selection

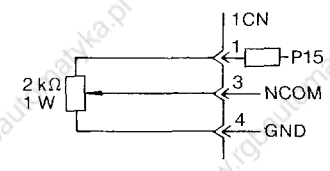
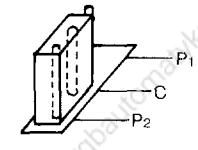
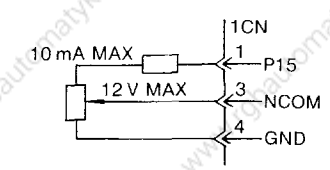
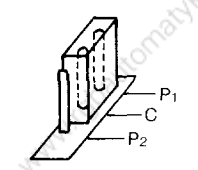
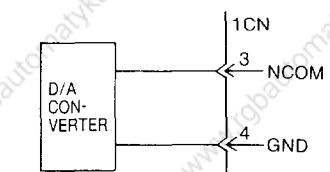
Speed Command Input	Analog Command Power Supply Selector	Speed Command Selection DAS
<p>When 2kΩ potentiometer is used.</p> 	<p>Select P2 and C pins.</p> 	
<p>When a potentiometer other than 2kΩ is used.</p> <p>Analog Command</p> 	<p>Select P1 and C pins.</p> 	Open
<p>When D/A converter is used.</p> 	<p>Select any of P1 and C or P2 and C.</p>	
<p>Digital Command</p> <p>12-bit binary</p> <p>3-digit BCD</p> <p>2-digit BCD</p>		Closed

8. 6 FAULT DETECTION IN ISOLATION AMPLIFIER IN BASE DRIVE

- Faults in the isolation amplifier in the base drive can be made with the control PCB, base drive PCB and the new version PROM.
- Selection is made with the ABC selection connectors in the center of the control PCB.

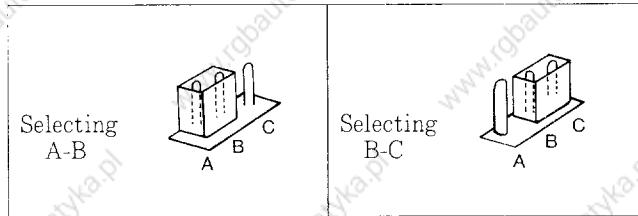

How to select shunt connectors

The fault detection function is available with only the new version controller, new version base driver and the new version software used in conjunction. When some of them are in the conventional version, selection must be made as shown below: Wrong selection will result in Adc and FU alarms.

		Base driver Version		Capacity	Conventional	New
				Controller Version	P-ROM Version	3.7k~7.5k
11k~15k	ETC-8590 -8591 -8592	ETC-8593 and subsequent				
18.5k~22k	—	ETC-8570 and subsequent				
30k	—	ETC-8880 and subsequent				
Conventional	ETC -8570 -8570·1 -8571 (Base Type)	Irrelevant		No selection connector	No selection connector	
New	Conventional	NSN -151 and earlier NSN -1005 and earlier	A-B Selection of B-C results in Adc alarm	A-B Selection of B-C results in Adc alarm		
	New	NSN -152 and subsequent NSN -1006 and subsequent	A-B Selection of B-C results in FU alarm	B-C Selection of A-B results in loss of fault detection function		

Note : When the selection connectors are set to A-B, the ISO-AMP fault detection functions are all lost.

9. OPERATION ON THE SETTING PANEL

9.1 FUNCTIONS OF THE SETTING PANEL

The following operations can be performed on the setting panel.

- LED display of control signal
- Display of trace-back data
- Display and setting of control constants
- Display of malfunctions

9.2 LED DISPLAY AND OPERATION KEYS

The LED display and the operation keys are shown in Fig. 9.1.

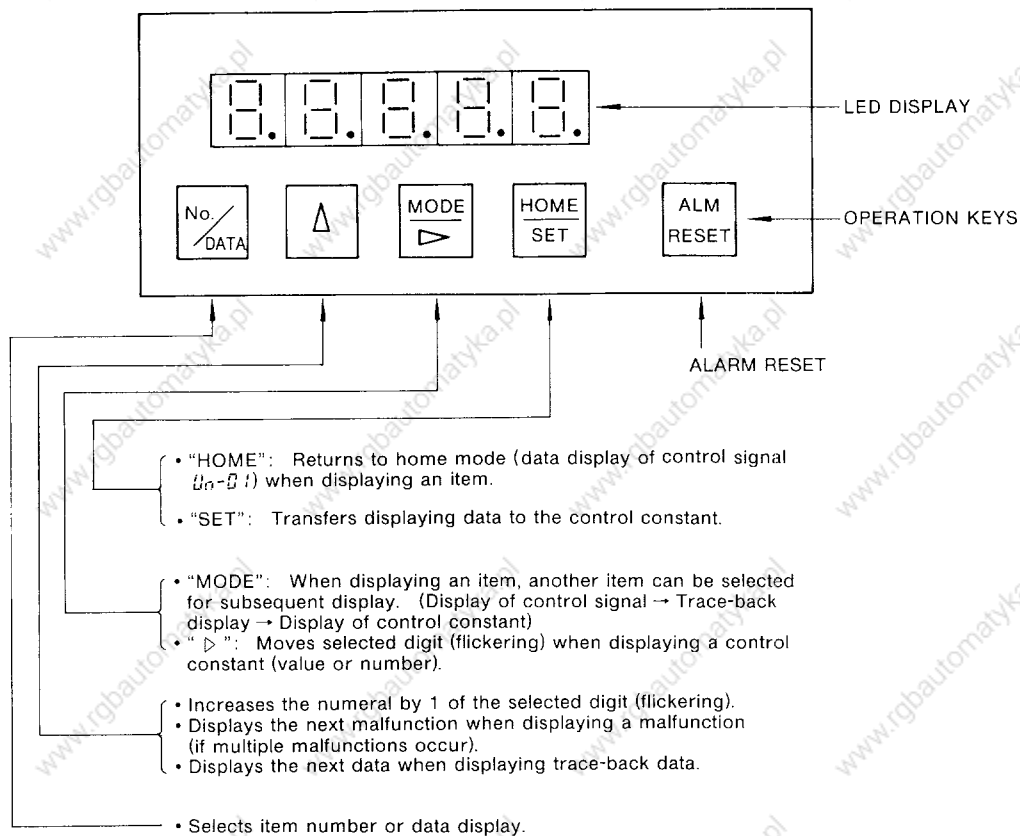

Fig. 9.1 LED Display and Operation Keys of the Setting Panel

9. 3 KEY OPERATION AND LED DISPLAY (EXAMPLE OF OPERATION)

Operation of the functions described in par. 9.1 is as follows:

9. 3. 1 Home Mode Display (Immediately after Power ON)

- Data display of control signal U_n-01

9. 3. 2 Control Signal Display

- Display of the control signal item number

Depress  key.

- Selection of control signal item U_n-2

Depress  key.

- Display of the contents

Depress  key.

- Return to display of the item number

Depress  key.

9. 3. 3 Trace-back Display

- Display trace-back item number

Depress  key.

Note: Trace-back data display is performed by the same operation as control signal data display.

- Control constant item display

Depress  key.

9. 3. 4 Display and Setting of Control Constants

- Display contents

Depress  key.

- Selection of the digit of the control constant to be changed

Depress  key twice.

(The selected digit blinks.)

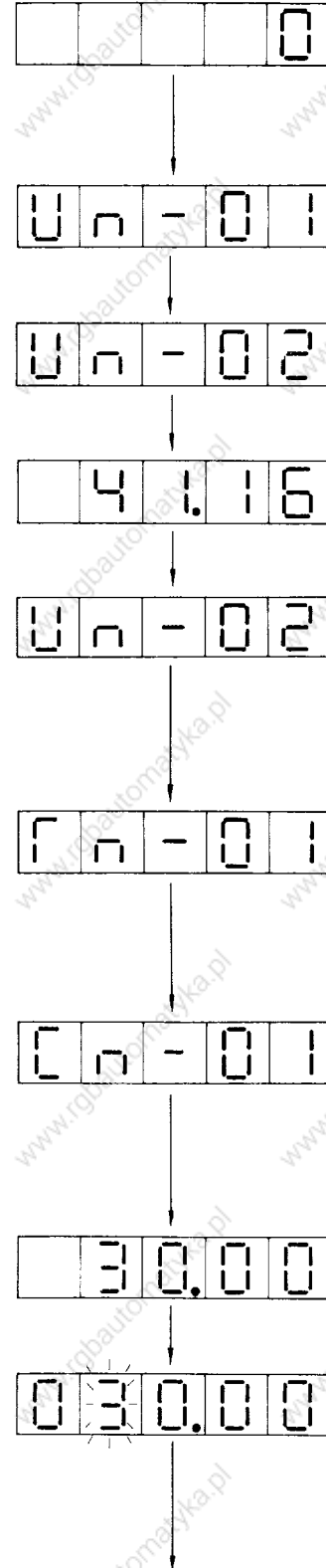

- Data change from 30.00 to 50.00

Depress  key twice.

- Setting of the changed constant

Depress  key.

- Depress  key for 1.5 seconds

- * When setting the data other than setting range of constants, all digits blink.

• Depress  key.

- Setting of the data other than setting range of [n-0].

On this status be sure to display item.

Depress  key.

9. 3. 5 Return to the Home Mode

- Return to display of the item number.

Depress  key.

Home mode display

Depress the  key.

Note: The return to the home mode can be accomplished any time during item number display, provided there is no failure.

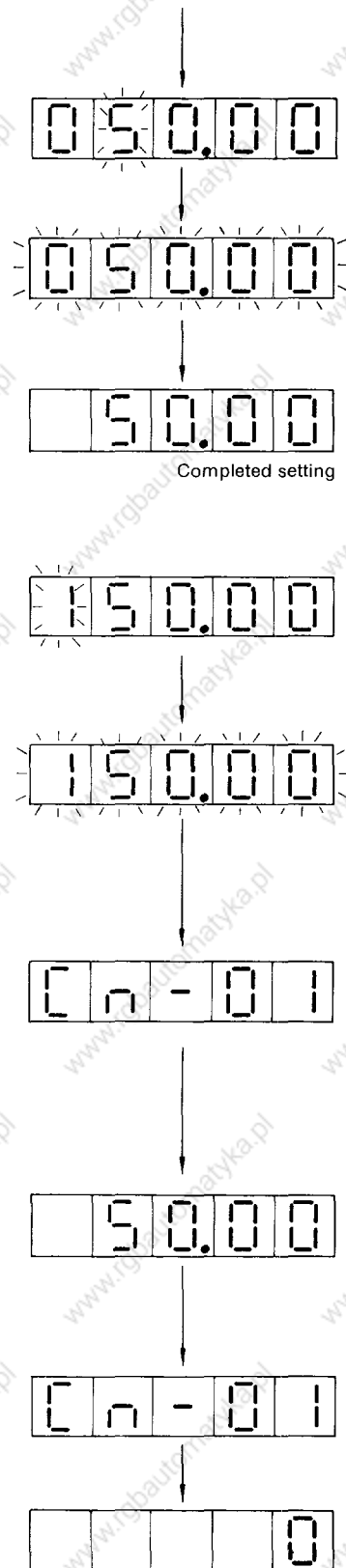

9.4 ALARM DISPLAY

Even if multiple malfunctions occur, a maximum of four malfunctions as well as the order of occurrence are stored, for later information. The following is an example of the sequence in case of a malfunction.

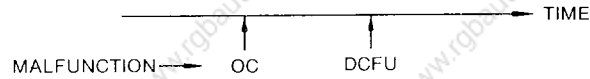

- Data display of home mode (control signal 00-00)



If a malfunction is detected, it is automatically displayed.

- -IOC display

Depress  key.

- FU display

Depress  key.

Note: Depress  key when malfunction is displayed, to select trace-back display. Then, depress  key during trace display to display the malfunction again.

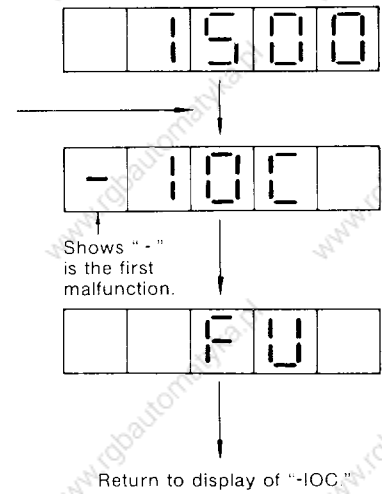

9.5 CONTROL SIGNALS

The actual contents of the control signals of par. 9.1 are shown in Table 9.1. U_n-05 , 07 and 08 are bit information. Figs. 9.2 and 9.3 are the contents of each bit.

Table 9.1 List of Control Signals

LED Display	Code	Name	Unit	Display at Power ON
U_n-01	NFB	Motor speed	r/min	0
U_n-02	NREF	Speed command	%	000
U_n-03	TREF	Torque command	%	00
U_n-04	MTEMP	Motor temperature	°C	Motor temperature
U_n-05	STATUS	Internal state	Hexadecimal	Varies depending on internal state
U_n-06	ALM	Alarm state	Hexadecimal	0000
U_n-07	DIDSP	Interface input state	Bit	See Fig. 9.2.
U_n-08	DODSP	Interface output state	Bit	See Fig. 9.3.
U_n-09	NFBS	Spindle speed	r/min	0
U_n-10	FLUX	Magnetic flux command	%	250

Note: U_n-01 to -08 are trace-back data. Refer to Par. 9.3.3 "Trace-back Display"

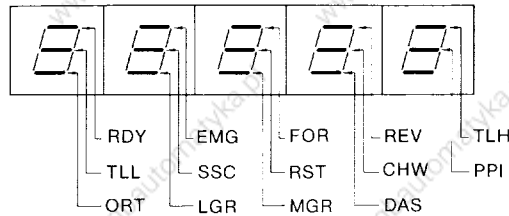

Fig. 9.2 Bit Display of DIDSP (U_n-07)

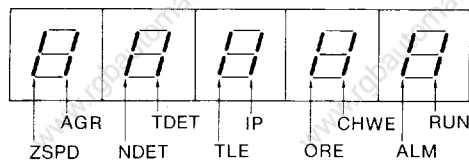

Fig. 9.3 Bit Display of DODSP (U_n-08)

10. TEST RUN

CAUTION

Observe the following precautions before turning on the power:

- Check to be sure that there is no obstacle interrupting operations.
- Warn the personnel nearby before starting operation.

Turn on the power for VS-626MTⅢ after securing safety around the equipment.

10.1 CHECKING AFTER POWER ON

When the power is turned on, the cooling fans of VS-626MTⅢ controller and motor begin to rotate. Check the following:

10.1.1 AC Spindle Motor

Check that the direction of cooling air is as shown in Fig. 10.1. If the reverse direction of cooling air in Fig. 10.1 is required, contact your Yaskawa representative.

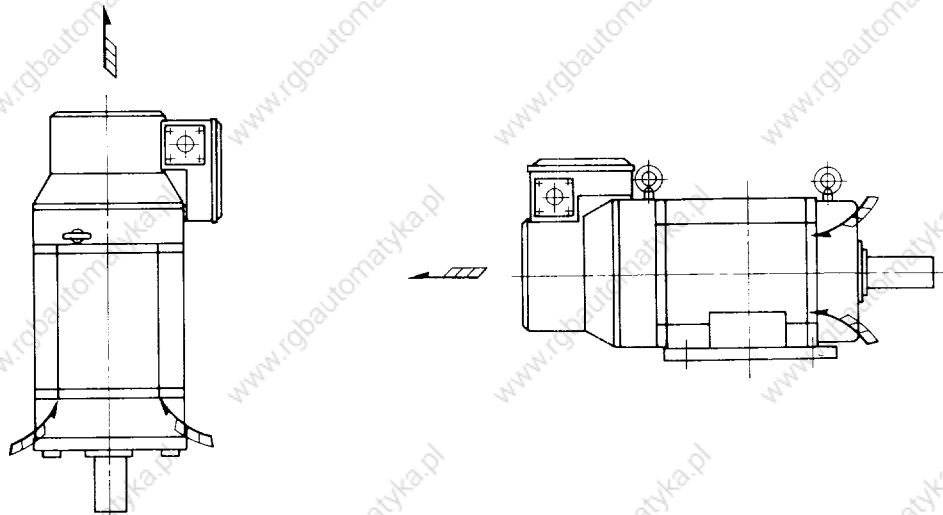

(a) Flange-mounted Type

(b) Foot-mounted Type

Fig. 10.1 Flow of Cooling Air of AC Spindle Motor

10.1.2 VS-626MTⅢ Controller

After turning on the power, "0" is displayed on the LEDs of the setting panel, and "CHARGE" will light dimly (red). If the emergency stop signal (EMG) and the ready signal (RDY) are closed, "CHARGE" will light brightly (red). But in case of any malfunction, or in case the above normal display is not made, investigate in accordance with par. 14.

10.2 STATE DISPLAY

The states of the VS-626MTIII controller and the motor can be monitored by displaying the contents of U_{n-01} to -10. Immediately after turning on the power, the motor speed (U_{n-01}) is displayed. Check that other state displays are as shown in Table 9.1.

10.3 CONTROL CONSTANTS

Control constants are set at the factory before delivery according to the constant setting table. Before turning power ON, check the setting panel to assure that the constants which can be referred to are the same as the initial setting value. If they do not correspond to the constants of the constant setting table, reset the constants using the setting panel. Refer to the constant setting value list (provided under separate cover) for the preset values other.

Table 10.1 Setting Range and Initial Setting Value of Constants

Code No.	Code	Description	Lower* Limit	Upper* Limit	Unit
01	PNORH	Speed control P (H gear)	1.00	100.00	
02	PNORL	Speed control P (L gear)	1.00	100.00	
03	PORTH	Speed control P (H gear, ORT)	1.00	100.00	
04	PORTL	Speed control P (L gear, ORT)	1.00	100.00	
05	NADJ	Motor speed adjustment	0.9000	1.5600	
06	SMADJ	Speedometer signal level adjustment	0.90	1.50	
07	LMADJ	Load meter signal level adjustment	0.90	1.10	
08	LMFS	Load meter full scale	120	350	%
09	EXTLIM	External operation torque limit	5	150	%
10	TSFS	Soft start time of speed reference	0.1	30.0	s
11	EMGTIM	Emergency stop monitoring supervisory timer	1	15	s
12	INORH	Speed control I (H gear)	100	1000	ms
13	INORL	Speed control I (L gear)	100	1000	ms
14	IORTH	Speed control I (H gear, ORT)	10	1000	ms
15	IORTL	Speed control I (L gear, ORT)	10	1000	ms
16	NDETL	Operation level of speed detection signal	0	100	%
17	DNDTL	Hysteresis width of speed detection signal	0.00	10.00	%
18	TDETL	Operation level of torque detection signal	5	120	%
19	PTAP	Speed control P (Servo mode)	1.00	100.00	
20	ITAP	Speed control I (Servo mode)	50	1000	ms
21	N 100	Motor rated speed	3500	N MAX†	r/min
22	HGEAR	H-gear ratio (Spindle speed/Motor speed)	0.050	1.500	
23	MGEAR	M-gear ratio (Spindle speed/Motor speed)	0.050	1.500	
24	LGEAR	L-gear ratio (Spindle speed/Motor speed)	0.050	1.500	
25	MOTOR	Motor code selection	0000	00FF	
26	SELCD 1	Selection code 1 (operation condition)	0000	FFFF	
27	SELCD 2	Selection code 2 (operation condition)	0000	FFFF	
28	ACCTLI	Torque limit level (motor side)	50	150	%
29	DECTLI	Torque limit level (brake side)	50	150	%
30	DI2LIM	I 2 rate limit	1.0	20.0	ms
31	IWLVL	Magnetic flux lower level	15	100	%
32	IWGAIN	Magnetic flux compensation level	25	50	%
33	PHAIWE	Magnetic flux level at orientation	15	100	%
34	PHAILM	Magnetic flux upper level	50	120	%
35	PHITAP	Magnetic flux lower level of servo mode	50	100	%
36	CNB TAP	Base speed of servo mode	1.00	3.00	
37	NORT	Orientation speed	1.00	5.00	V
38	NCRP	Creep speed	0.05	2.00	V
39	AGREE	Speed agreement signal width	10	50	%
40	OFFSET	Analog speed reference offset adjustment	-10.00	10.00	%
41†	SPD1	Speed setting 1	0.00	100.00	%
42†	SPD2	Speed setting 2	0.00	100.00	%
43†	SPD3	Speed setting 3	0.00	100.00	%
44†	SPD4	Speed setting 4	0.00	100.00	%
45†	SPD5	Speed setting 5	0.00	100.00	%
46†	SPD6	Speed setting 6	0.00	100.00	%
47†	SPD7	Speed setting 7	0.00	100.00	%
48*	SPD8	Speed setting 8	0.00	100.00	%

* Lower-and-upper limit of the constant depends on enhancing PROM.

† The maximum speed of the motor.

* Code 41 to 48 do not exist for the winding selection system.

10.3 CONTROL CONSTANTS (Cont'd)

Applied PROM Software No.: NSN0001 × × ×

Table 10.2 VS-626MTIII Standard Constants Settings

Co-No.	Code	Lower Limit	Upper Limit	Unit	Motor Controller 37/22 kW 5.5/3.7 kW	Motor Controller 5.5/3.7 kW 5.5/3.7 kW	Motor Controller 7.5/5.5 kW 7.5/5.5 kW	Motor Controller 11/7.5 kW 11/7.5 kW	Motor Controller 15/11 kW 15/11 kW	Motor Controller 18.5/15 kW 18.5/15 kW	Motor Controller 22/18.5 kW 22/18.5 kW	Motor Controller 30/22 kW 30/22 kW
1	PNORH	1.00	100.00		20 (30)	20 (30)	20 (30)	20 (15)	20 (15)	20 (15)	20 (15)	20
2	PNORL	1.00	100.00		20 (30)	20 (30)	20 (30)	20 (15)	20 (15)	20 (15)	20 (15)	20
3	FORHL	1.00	100.00		30	30	30 (20)	30 (20)	30 (20)	30 (20)	30 (20)	30
4	FORLL	1.00	100.00		30	30	30 (20)	30 (20)	30 (20)	30 (20)	30 (20)	30
5	NADJ	0.9000	1.5000		1	1	1	1	1	1	1	1
6	SMADI	0.90	1.50		1	1	1	1	1	1	1	1
7	LMAID	0.90	1.10		1	1	1	1	1	1	1	1
8	LMPFS	120	350	%	200	200	200	200	200	200	200	200
9	EXTLJM	5	150	%	5	5	5	5	5	5	5	5
10	TSRPS	0.1	30.0	s	0.1	0.1	0.1	0.1	0.1	0.1	0.1	0.1
11	EMGTTM	1	15	s	10	10	10	10	10	10	10	10
12	INORH	100	1000	ms	600	600	600	600	600	600	600	600
13	INORL	100	1000	ms	600	600	600	600	600	600	600	600
14	IOFTH	10	1000	ms	200	200	200	200	200	200	200	200
15	IOFTL	10	1000	ms	200	200	200	200	200	200	200	200
16	NDETL	0	100	%	10	10	10	10	10	10	10	10
17	DNDTL	0.00	10.00	%	1	1	1	1	1	1	1	1
18	TDETL	5	120	%	30	30	30	30	30	30	30	30
19	PTAP	1.00	100.00		20	20	20	20	20	20	20	20
20	ITAP	50	1000	ms	100	100	100	100	100	100	100	100
21	N100	3500	MAX RPM	r/min	6000 (8000)	6000 (8000)	6000 (8000)	6000 (<4500>)	6000 (<4500>)	6000 (<4500>)	6000 (<4500>)	4500
22	HGEAR	0.05	1.50		1.0	1.0	1.0	1.0	1.0	1.0	1.0	1.0
23	MGEAR	0.05	1.50		0.6	0.6	0.6	0.6	0.6	0.6	0.6	0.6
24	LGEAR	0.05	1.50		0.2	0.2	0.2	0.2	0.2	0.2	0.2	0.2
25	MOTOR	0000	00 FF		0002	0003	0004	0005	0006	0007	0008	0008
26	SELCD1	0000	FFFF		22 A 4 * 26 A 4	02 A 4 * 06 A 4	02 A 4 * 06 A 4	22 A 4 * 26 A 4	02 A 4 * 06 A 4	22 A 4 * 26 A 4	22 A 4 * 26 A 4	22 A 4 * 26 A 4
27	SELCD2	0000	FFFF		0007	0007	0007	0007	0007	0007	0007	0007
28	ACCTLI	50	150	%	120	120	120	120	120	120	120	120
29	DECTLI	50	150	%	120	120	110	120	120	120	120	120
30	DI2LJM	1.0	20.0	ms	4	4	4	4	4	4	4	4
31	TWVLL	15	100	%	30	30	30	30	30	30	30	30
32	WVAIN	25	50	%	30	30	30	30	30	30	30	30
33	PHAIWE	15	100	%	50	50	50	50	50	50	50	50
34	PHAILM	60	120	%	100	100	100	100	100	100	100	100
35	PHITAP	50	100	%	70	70	70	70	70	70	70	70
36	CABTAP	1.00	3.00		2.0	2.0	2.0	2.0	2.0	2.0	2.0	2.0
37	NORT	1.00	5.00	V	2.5	2.5	2.5	2.5	2.5	2.5	2.5	2.5
38	NCRP	0.05	2.00	V	0.2	0.2	0.2	0.2	0.2	0.2	0.2	0.2
39	AGREF	10	50	%	15	15	15	15	15	15	15	15
40	OPFSET	10.00	100.00	%	Individually set	Individually set	Individually set	Individually set	Individually set	Individually set	Individually set	Individually set
41	SPD1	0.00	100.00	%	0	0	0	0	0	0	0	0
42	SPD2	0.00	100.00	%	0	0	0	0	0	0	0	0
43	SPD3	0.00	100.00	%	0	0	0	0	0	0	0	0
44	SPD4	0.00	100.00	%	0	0	0	0	0	0	0	0
45	SPD5	0.00	100.00	%	0	0	0	0	0	0	0	0
46	SPD6	0.00	100.00	%	0	0	0	0	0	0	0	0
47	SPD7	0.00	100.00	%	0	0	0	0	0	0	0	0
48	SPD8	0.00	100.00	%	0	0	0	0	0	0	0	0
Applied Controller Code No.					ETC 008572	ETC 008572	ETC 008572	ETC 008572	ETC 502852	ETC 008572	ETC 502852	ETC 502852
Tap Selection for Mounting Positional Stop Orientation Card					FS 200	AUTO	M	DIA	FS 200	AUTO	M	DIA

Notes: 1. () indicates the settings for 8000 r/min specifications.
 2. (< >) indicates the settings for 4500 r/min specifications.
 3. * indicates the solid tap specifications.

10.4 OPERATION

After checking with power on, supply a running signal to operate. Gradually increasing the speed reference from 0% starts the motor. Check that the direction of motor rotation is proper. The proper direction is counterclockwise as viewed from the motor shaft end when forward run signal (FORRN) is closed and the speed reference has a positive polarity.

A wrong phase sequence of the power cable between VS-626MTIII controller and motor or the PG signal can be considered if the direction of rotation is reverse, or if the motor creates excessive noise or vibrates, without rotating, during operation. Turn off the power and check the wiring.

Check that the motor smoothly accelerates and decelerates in both forward and reverse directions by changing the speed reference. At the same time, check that the motor is not vibrating or emitting noise excessively. The sound of the motor constantly audible at several thousand hertz is caused by the control system and presents no problem.



Speed Reference	+	-
Signal	FOR	REV
	CCW	CW
	CW	CCW

Fig. 10.2 Direction of Motor Rotation

CAUTION

- Start the motor after confirming that the motor is completely stopped. If the motor is started during coasting, overvoltage (OV) or overcurrent (OC) may occur.
- Do not turn on MCCB in the VS-626MTIII controller after turning on the power. Tripping may occur due to the charging current to capacitors.
(Power supply OFF → MCCB ON → Power supply ON)

11. SETTING AND ADJUSTMENT

VS-626MTIII controller is preadjusted at the factory. Normally, readjustment is not required. However, the setting value shown in Table 10.1 can be changed, depending on operation specifications.

11.1 SETTING

11.1.1 Load Meter Full Scale Setting (LMFS... [0-08])

The load meter indicates the output ratio(%) with the maximum output of the motor during operation. Write the load meter full scale value(% of continuous rating) in control constant [0-08].

11.1.2 External Torque Limit Level Setting (EXTLIM... [0-09])

This constant is used to operate the torque limit externally. It can be set in the range of 5% to 150% of the 30-minute rating output.

11.1.3 Soft Start Time Setting (TSFS... [0-10])

The soft start time is the time required for an acceleration/deceleration command to be reached from 0 r/min to rated speed or from the rated speed to 0 r/min. The soft start time can be set in the range of 0.1 to 30.0 seconds. The command and the time are related as follows.

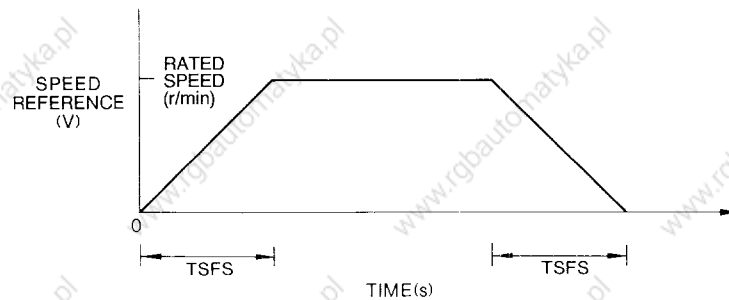

Fig. 11.1 Soft Start Time Setting

11.1.4 Rated Speed Setting (N100... [0-2])

Set the rated speed according to the specifications of the machine tool. The motor rotates at this rated speed when 100% is input as the speed command value.

The rated speed can be set in the range from 3500 r/min up to maximum motor speed.

11.1.5 Speed Detection Level (NDETL ... [n-15])

The external output signal **NDET** will be closed when the motor speed falls below this setting value. The LEDs on the setting panel will display the following when control signal U_{n-09} is called up.

The speed detection level can be set in the range of 0% to 100%.

Hysteresis width can be set to 0 to 10 % in [n-17].

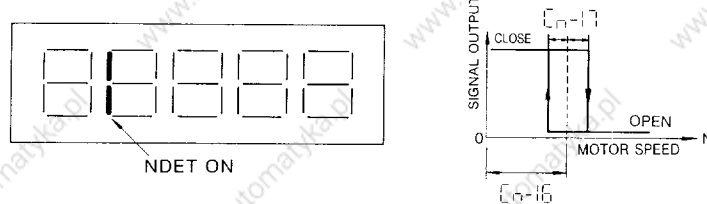

11.1.6 Torque Detection Level Setting (TDETL ... [n-18])

This signal is used to set the operation level of the torque detection signal **TDET** (**TDET** closes when torque decreases below a specified level). When **TDET** is closed, the LEDs on the setting panel will display the following when control signal U_{n-08} is called up. The torque detection level can be set in the range of 5% to 150% of the 30-minute rating output.

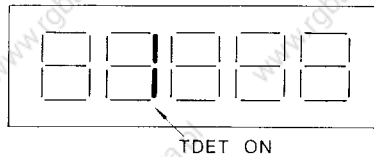

11.1.7 Speed Coincidence Range Setting (AGREE ... [n-19])

This signal is used to set the operating range of the speed coincidence signal **AGREE** (**AGREE** closes when speed coincides.) The speed coincidence range can be set in the range of 10% to 50%.

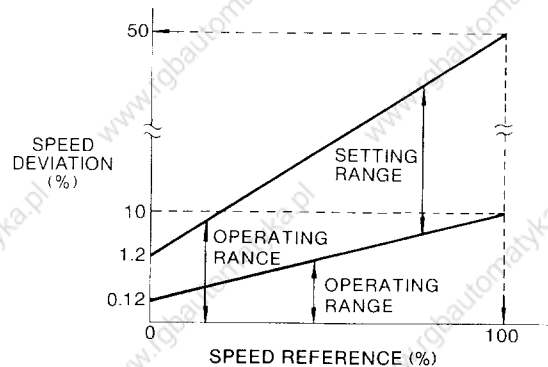

Note: Speed deviation is expressed as a percentage of 100% speed reference.

Fig. 11.2 Speed Coincidence Range Setting

11. 1. 8 Gear Ratio Setting

H-gear ... [n-22]
M-gear ... [n-23]
L-gear ... [n-24]

The gear ratio should be set to suit gear ratio(or pulley ratio) which is determined according to the specifications of the machine tool. The spindle speed is operated and displayed by this constant.

This gear ratio is also used as constants at orientation operation.

The gear ratio can be set in the following range:

H-gear ... 0.050 to 1.500
M-gear ... 0.050 to 1.500
L-gear ... 0.050 to 1.500

$$\left(\text{Gear ratio} = \frac{\text{Spindle speed}}{\text{Motor speed}} \right)$$

NOTE

H-gear, M-gear, or L-gear is selected by the external signal as shown in the following table.

External Signal	M-gear	L-gear
H-gear	OFF	OFF
M-gear	ON	OFF
L-gear	OFF	ON

11. 2 ADJUSTMENT

11. 2. 1 Adjustment of Motor Speed (NADJ ... [n-05])

Readjust as follows, when a fine adjustment of the absolute value of the spindle speed (motor speed) is required.

1. Rotate the motor in the forward direction, measure the speed reference voltage with a voltmeter and set it to the reference voltage of the desired speed.
2. Measure the speed with a speedometer after the reference voltage is adjusted.
3. Set the NADJ value larger than the current value if the speed does not reach the desired speed. Adjust NADJ until the desired speed is obtained.
4. Set the NADJ value smaller than the current value if the speed exceeds the desired speed.

NOTE

If there is no speedometer available, the speed can also be set using the setting panel ([n-0]). In that case, the speed cannot be monitored while setting the NADJ.

11.2.2 Adjustment of Speedometer (SMADJ... [0-05])

For fine adjustments of the speedometer, the potentiometer is set to output 10V at the rated speed at the factory. Adjust as follows, if the output deviates.

1. Set the speed command at the rated speed.
2. When the speedometer shows a lower value than the rated speed, set the SMADJ value larger than the current value, so that it indicates the rated speed.
3. When it shows a higher value than the rated speed, set the SMADJ value smaller than the current value, so that it indicates the rated speed.

11.2.3 Adjustment of Load Meter (LMADJ... [0-07])

For fine adjustments of the load meter, the LMADJ is preset at the factory to output the voltage shown in Table 11.1 at 120% of 30-minute rating. Adjust as follows, if the output deviates.

1. Display the constant [0-07] (for adjusting load meter) on the setting panel.
2. Depress

HOME
SET

 and

ALM
RESET

 keys simultaneously.
Then the voltage equivalent to 120% output of 30-minute rating is output from load meter output (1CN or screw terminal ②).
3. If the load meter indicator indicates a larger value than the % setting value of Table 11.1, set the LMADJ smaller than the current value, so that it becomes the prescribed %.
4. If it is smaller than the % setting value, adjust the LMADJ to a larger value so that it becomes the prescribed %.
5. Change the display of load meter adjustment (LMADJ... [0-07]) to another display on the setting panel. Then the load meter outputs the regular value.

Table 11.1 Load Meter Output Voltage on 30-minute Rating at 120% Output

30-minute Rating/Continuous Rating kW (HP)	Load Meter Full Scale	170%	180%	200%
		Load Meter Output V	Load Meter Output V	Load Meter Output V
3.7/2.2 (5/3)		*	*	10.0 [200%]
5.5/3.7 (7.5/5)		*	10.0 [180%]	9.0 [180%]
7.5/5.5 (10/7.5)		9.6/ [163%]	9.0 [162%]	8.1 [162%]
11/7.5 (15/10)		*	9.8 [177%]	8.8 [176%]
15/11 (20/15)		9.6/ [163%]	9.0 [162%]	8.1 [162%]
18.5/15 (25/20)		8.7/ [148%]	8.2 [148%]	7.4 [148%]
22/18.5 (30/25)		8.4/ [143%]	7.9 [142%]	7.1 [142%]
30/22 (40/30)		9.6/ [163%]	9.0 [162%]	8.1 [162%]

* Cannot be set.

Note: % in [] is meter indication.

11.2.4 Adjustment of Loop Gain of Speed Control System (Cn-01 to -04)

PNORH ... Speed gain (H-gear)	Cn-01
PNORL ... Speed gain (L-gear)	Cn-02
PORTH ... Orientation speed gain (H-gear)	Cn-03
PORTL ... Orientation speed gain (L-gear)	Cn-04
PTAP ... Solid tap speed gain	Cn-19

This is used for adjustment of loop gain of speed control system. The five constants listed above can be adjusted respectively, depending on the operation mode. The closer the setting is brought to 0, the lower and more stable the gain becomes, but the response becomes slower. The larger the setting is adjusted, the quicker becomes the response, but the control system tends to become unstable. Adjust it to the optimum gain, taking into consideration the load conditions.

Adjusting range of the constants is as follows:

- Speed gain(H-gear) 1 to 100
- Speed gain(L-gear) 1 to 100
- Orientation speed gain(H-gear).... 1 to 100
- Orientation speed gain(L-gear).... 1 to 100
- Solid tap speed gain 1 to 100

NOTE

Loop gain of speed control drives changes depending on rated speed settings (N100-Cn-21). It is determined through speed setting ratio for motor maximum speed.

$$\text{Internal Speed Gain} = \text{Speed Gain Set Point} \times \left(\frac{\text{Motor Maximum Speed}}{\text{Rated Speed Setting } Cn-21} \right)^2$$

(Cn-01, 02, 03, 04, 19)

ex.) 5.5kW motor standard type (maximum speed 8000 r/min)
Cn-21 setting ... 8000 r/min Cn-01 setting ... 30

$$\text{Internal Speed Gain} = 30 \times \left(\frac{8000}{8000} \right)^2 = 30$$

Gain has no change.

ex.) 5.5kW motor standard type (maximum speed 8000 r/min)
Cn-21 setting ... 3500 r/min Cn-01 setting ... 30

$$\text{Internal Speed Gain} = 30 \times \left(\frac{8000}{3500} \right)^2 \approx 157$$

Very high gain and not stabilized.

If internal speed gain is standard at approx. 30,

$$30 \div \left(\frac{8000}{3500} \right)^2 \approx 6$$

Cn-01 setting 6 shall be approx. 30 and be stable. Cn-02, 03, 04, -19 are the same.

Maximum speed of standard type motors is shown in the table below.

Motor Capacity (kW)	3.7/2.2	5.5/3.7	7.5/5.5	11/7.5	15/11	18.5/15	22/18.5	30/22
Maximum Speed (r/min)	8000	8000	8000	6000	6000	6000	6000	4500

12. VS-626MTⅢ CHECK TERMINALS AND THEIR SIGNALS

Table 12.1 VS-626MTⅢ Check Terminals and Their Signals

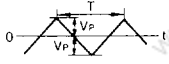
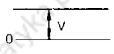
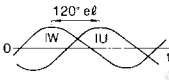
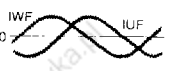
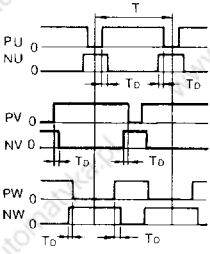
	Check Terminal	Signal	Description	Note	
Control Circuit Board	FCT	PWM carrier signal	 $V_p = 6\text{ V} \pm 0.5\text{ V}$ $T = 300\mu\text{s} \pm 30\mu\text{s}$	Check at motor stop	
	VR	Current reference		V becomes large under load and small under no load.	0 V at motor stop
	IU	Phase U current reference	 $120^\circ \text{ e}\ell$	IW is led at forward run.	0 V at motor stop
	IW	Phase W current reference		IU is led at reverse run.	
	IUF	Phase U current		IWF is led at forward run.	0 V at motor stop
	IWF	Phase W current		IUF is led at reverse run.	
	PU	PWM signals		$T = 300\mu\text{s} \pm 30\mu\text{s}$ $T_p = 20 \text{ to } 30\mu\text{s}$	Example of low speed operation
	NU				
	PV				
	NV				
PW					
NW					
GND	Signal ground		0 V		
Base Drive Circuit Board	VC	+5 V		+5 V \pm 0.25 V	
	P15	+15 V		+15 V \pm 0.15 V	
	N15	-15 V		-15 V \pm 0.15 V	
	P25	+25 V		+25 V \pm 2 V	
	P24	+24 V		+24 V \pm 2 V	
	GND	Signal ground		0 V	

Note:

1. The check terminals allow oscilloscope connection for measurement.
2. During measurement, do not short the adjacent two check terminals, as the connected elements may be destroyed.
3. IUF, IWF current conversion ratio is shown in the table below.

Inverter Capacity	3.7kW	5.5kW	7.5kW	11kW	15kW	18.5kW	22kW	30kW
Current Conversion Ratio	6V/100A		6V/200A		6V/300A		6V/400A	

13. MAINTENANCE

VS-626MTIII requires very few routine checks, but regular periodical maintenance is necessary to maintain normal and smooth operating conditions. Formulate a maintenance schedule after studying the maintenance items shown below.

CAUTION

Do not touch the inside components of VS-626MTIII for 5 minutes after turning off the power supply. Before servicing inspection, check that the smoothing capacitors have been completely discharged. This can be verified by the "CHARGE" lamp being off.

13.1 DAILY INSPECTION ITEMS

For the spindle motor, daily inspection of the following items should be performed:

- Rated speed is correct.
- Cooling fan rotates smoothly.
- Cooling air circulates normally.
- No abnormal vibration
- No abnormal sound
- No abnormal odor

VS-626MTIII controller requires almost no routine checks since it has been designed with highly reliable circuit technology and is comprised mostly of semiconductors, such as ICs and power transistors.

13.2 PERIODIC CLEANING

The VS-626MTIII controller must be cleaned periodically as follows.

- If the controller has air filters, these must be cleaned once a month.
- Dust and dirt on the electric parts will deteriorate the insulation or cause over-heat. These must also be cleaned periodically. The radiating efficiency of the regenerative resistor and the heat sink at the rear of the controller will also deteriorate and cause malfunctions if coated with dust. Clean these once every 6 months with an air blower or wiping with a dry cloth. Clean them more often if conditions require.

13.3 PERIODIC INSPECTION

To maintain the AC spindle motor and VS-626MTⅢ controller in good operating order, perform periodical inspection and maintenance referring to Table 13.1.

Table 13.1 Periodic Inspection Items and Description

Item	Check	Corrective Action	
AC Spindle Motor	Cooling Fan	<ul style="list-style-type: none"> Abnormal sound or vibration. Cumulative operating time exceeds 20,000 hours. 	Replace cooling fan.
	Motor Bearing	<ul style="list-style-type: none"> Abnormal sound High temperature 	Contact Yaskawa representative.
	Cooling Air, Inlet Port, Exhaust Port, Air Passage	<ul style="list-style-type: none"> Coating of dust or oil. 	Clean approximately once every 6 months or more frequently, depending on operation conditions. Coating of dust or oil in air passage may decrease cooling efficiency and cause malfunctions.
VS-626MTⅢ Controller	External Terminals, Unit Mtg Bolts, Connectors, etc.	Loosened screws / bolts.	Tighten.
	Cooling Fan	<ul style="list-style-type: none"> Abnormal sound or vibration. Cumulative operating time exceeds 20,000 hours. 	Replace cooling fan.
	Printed Circuit Board	Discoloration—brown color	Replace the board.
	Smoothing Capacitor	Discoloration or unusual odor	Replace the capacitor or inverter unit, as necessary.
	Air Filter (Control panel)	Coating of dust	Clean once a month.
	Electronic Parts	Coating of dust	Remove dust periodically.
	Regenerative Resistors, Heat Sink (on the Rear of VS-626MTⅢ Controller)	Coating of dust	Remove dust with air blower or a dry cloth once every 6 months or more frequently, depending on operation conditions. Dust accumulated on regenerative resistors or heat sink may decrease radiating efficiency and cause malfunctions.

13.3.1 Prolonged Storage

If VS-626MTIII controller is installed as a standby unit, or is kept out of operation for a long period of time, check its operation at least once every six months by turning on the power supply.

Reformation is necessary for electrolytic capacitors if they have not been used for a long time (more than 1 year). Reformation can be accomplished in the following way:

1. Turn off the Ready signal, then turn on the power. "CHARGE" lamp (red) lights dimly.
2. After 5 minutes, turn on the Ready signal. "CHARGE" lamp (red) lights brightly.
3. Let the controller stand for 30 minutes.

13.4 CHECKING SEMICONDUCTOR ELEMENTS FOR MAIN CIRCUIT

When checking semiconductor elements for main circuit, remove the base drive circuit board (See par. 13.5). When remounting the base drive circuit board, connect the connector leads to the specified connector terminals and screws correctly and tighten them firmly. If only one screw is loose, or missing the VS-626MTIII system will not operate properly.

13.4.1 Transistor Module

Checking Method

Measure the resistance value at the terminals shown in Tables 13.2, 13.3 and 13.4, with an ohmmeter.

Table 13.2 Resistance of Power Transistor Module for Main Circuit

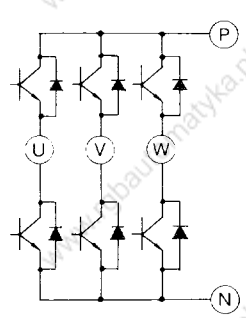
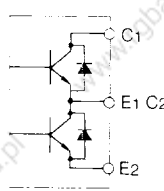
VS-626MTIII Controller Model CIMR-MTIII-	Ohmmeter Terminal ⊖	Ohmmeter Terminal ⊕	Reference Resistance	Abnormal Resistance	Transistor Module Terminals	
3.7K 5.5K 7.5K	P	U	∞	0 Ω		
		V				
		W				
	U	N	Several Ω to approximate multiple of 10 Ω	0 Ω or ∞		
						V
						W
11K 15K 18.5K 22K 30K	C ₁	E ₁ , C ₂	∞	0 Ω		
	E ₁ , C ₂	E ₂	Several Ω to approximate multiple of 10 Ω	0 Ω or ∞		
	E ₁ , C ₂	C ₁				
	E ₂	E ₁ , C ₂				

Note : Use the ohmmeter set at $\times 1 \Omega$ range.

Table 13.3 Resistance of Power Transistor Module for Regenerative Circuit

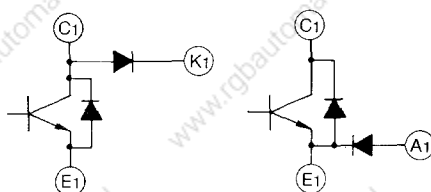
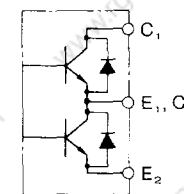
VS-626MTIII Controller Model CIMR-MTIII-	Ohmmeter Terminal ⊖	Ohmmeter Terminal ⊕	Reference Resistance	Abnormal Resistance	Power Transistor Module for Regenerative Circuit
3.7K 5.5K 7.5K 11K 15K	C ₁	E ₁	∞	0Ω	
	K ₁	C ₁			
	E ₁	C ₁	Approximate multiple of 10Ω	0Ω or ∞	
	C ₁	K ₁			
	C ₁	E ₁	∞	0Ω	
	E ₁	A ₁			
	E ₁	C ₁	Several Ω to approximate multiple of 10Ω	0Ω or ∞	
A ₁	E ₁				
18.5K 22K 30K	C ₁	E ₁ , C ₂	∞	0Ω	
	E ₁ , C ₂	E ₂			
	E ₁ , C ₂	C ₁	Several Ω to approximate multiple of 10Ω	0Ω or ∞	
	E ₂	E ₁ , C ₂			

Note: Use the ohmmeter set at × 1Ω range.

13.4.2 Thyristor Module

Checking Method

Measure the resistance value at the terminals shown in Table 13.4.

Table 13.4 Resistance of Diode Module

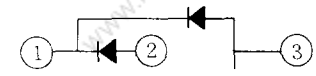
VS-626MTIII Controller Model CIMR-MTIII-	Tester Terminal	⊖	⊕	Reference Resistance	Abnormal Resistance
18.5 K 22 K 30 K	DIODE MODULE TERMINAL 	①	②	∞	Less than Approximate multiple of 10Ω
		①	③		
		②	①	Less than Approximate multiple of 10Ω	∞ or 0Ω
		③	①		

Note: Use the ohmmeter set at × 1Ω range.

13.4.3 Diode Module

Checking Method

Measure the resistance value the terminals shown in Table 13.5.

Table 13.5 Resistance of Thyristor Module

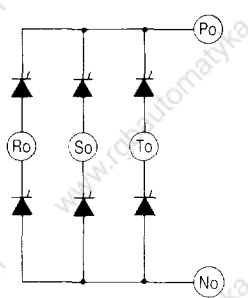
Ohmmeter Terminal ⊖	Ohmmeter Terminal ⊕	Reference Resistance	Abnormal resistance	Thyristor Module for Regenerative Circuit
P _o	R _o	∞	Approximate multiple of 10Ω or below	
	S _o			
	T _o			
R _o	N _o			
S _o				
T _o				
R _o	P _o			
S _o				
T _o				
N _o	R _o			
	S _o			
	T _o			

Note: Use the ohmmeter set at $\times 1\Omega$ range.

13.5 REPLACEMENT OF PRINTED CIRCUIT BOARDS

If the printed circuit boards are replaced, see Table 15.1, contact Yaskawa representative with parts name, parts code No. and quantity.

CAUTION

Do not replace the printed circuit boards or remove the connectors when power supply is ON since the parts of the circuit may be damaged.

13.5.1 Replacement of Control Circuit Board

(1) Removal Procedures (Fig. 13.1)

1. Turn off the power supply and disconnect the connectors (1CN to 3CN, 1FC, 2FC) and the ground lead from the control circuit board (PCB).
2. Remove the five PCB mounting screws (M4).
3. Hold each head of the PCB supports with round-nose pliers and remove the supports from the guide holes in the PCB (Fig. 13.2).

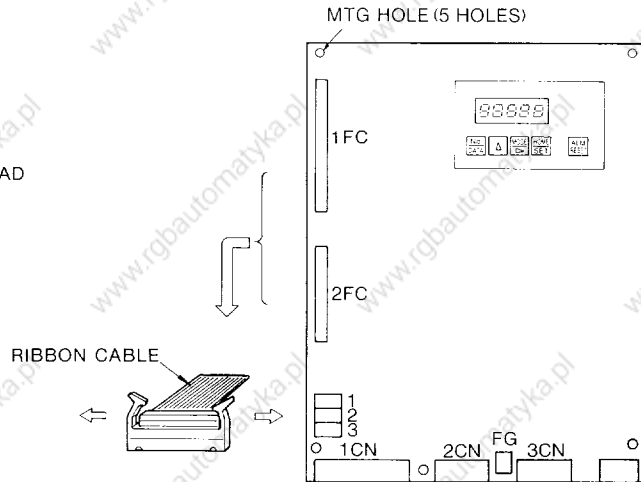
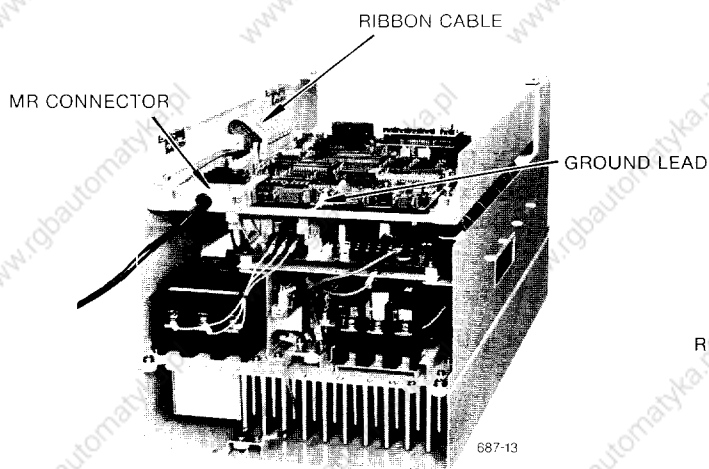

Fig. 13.1 Removal of Control Circuit Board

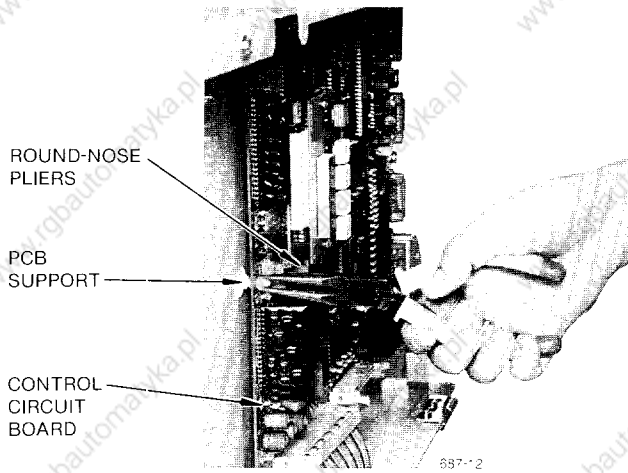

Fig. 13.2 Holding Head of PCB Support with Round-nose Pliers

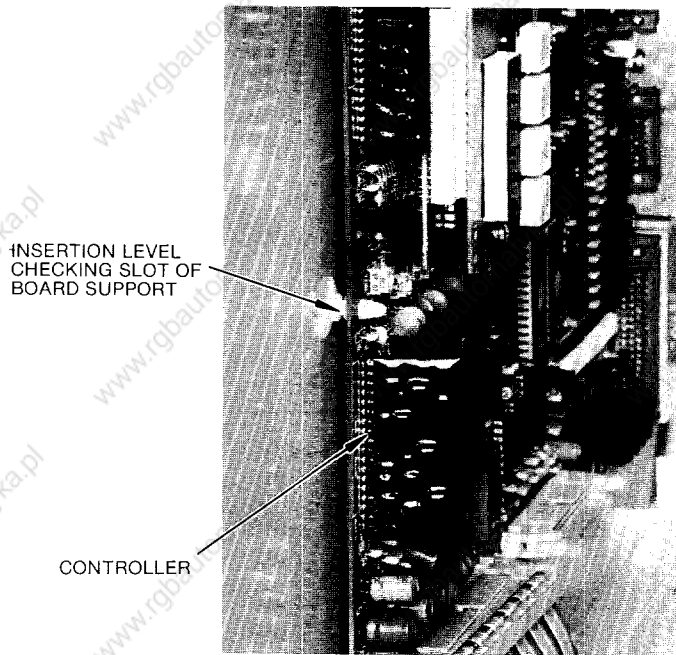

Fig 13.3 Controller Mounting

(2) Mounting Procedures

1. Insert the control circuit board in PCB supports until it comes fully to the checking groove in the supports. (See Fig. 13.3.)
2. Secure the PCB to the PCB mounting board with screws at five positions.
3. Connect the cables to the connectors.
4. Check the setting of the PCB and start operation.

13.5.2 Replacement of Base Drive Board

The board is mounted at the rear side of the PCB mounting board.

(1) Removal Procedures (Fig. 13.3).

1. Turn off the power supply, open the control circuit PCB mounting board and disconnect the connectors (1 to 12CN for 7.5K and below, to 16CN for 11 to 22K, 1 to 18CN for 30K), the ground lead and the power lead for cooling fan (u, v) from the base drive board.
2. Remove the PCB mounting screws and three power connecting screws.
3. Hold each head of the PCB supports with round-nose pliers and remove the supports from the guide holes in the PCB.

(2) Mounting Procedures

1. Insert the base drive board in PCB supports until it comes fully to the checking groove in the supports.
2. Secure the PCB to the PCB mounting board with screws at four or nine positions.
3. Connect the cables to the connectors.
4. Check the setting of the PCB and start operation.

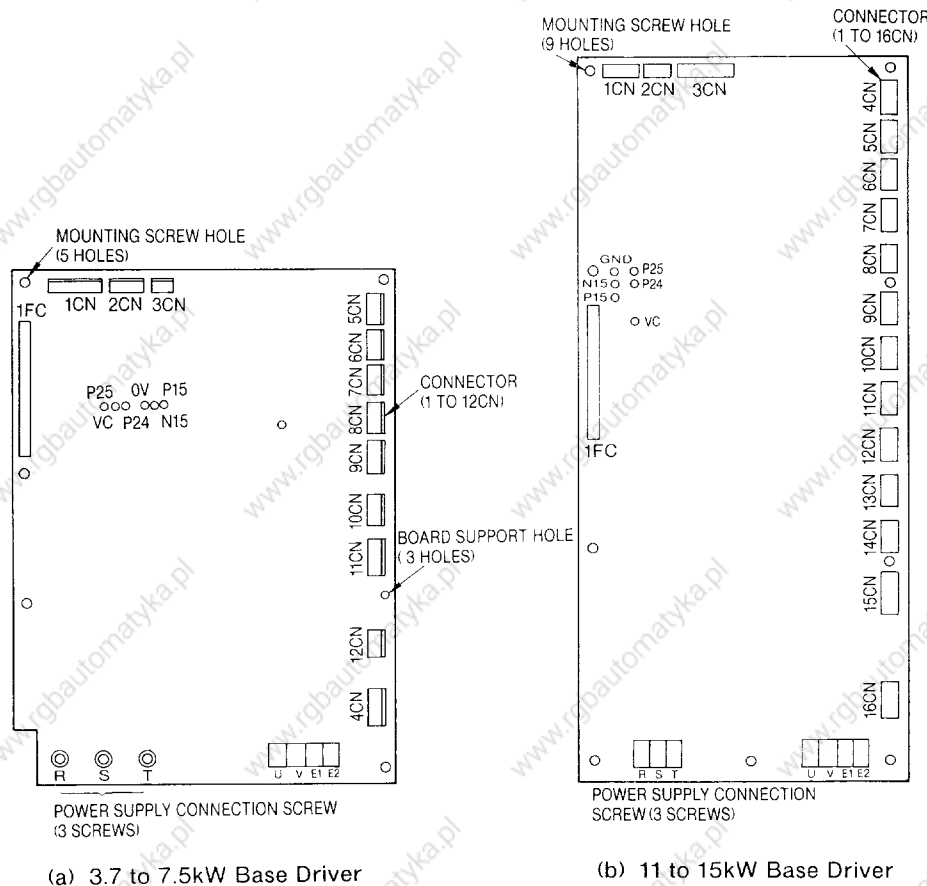
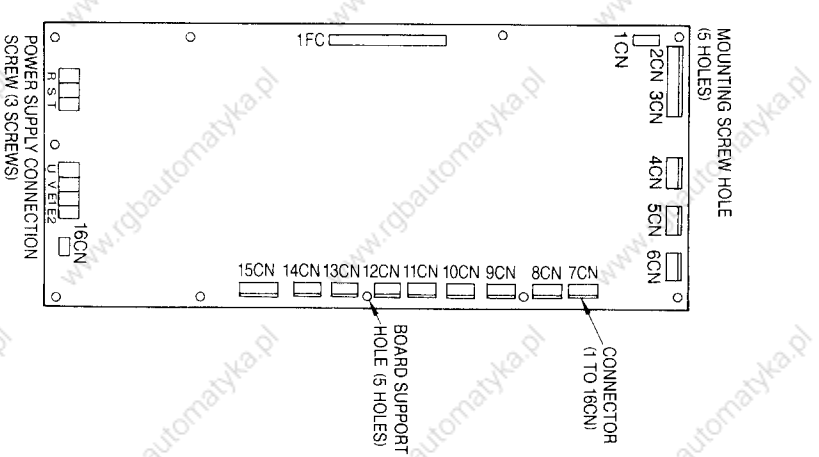
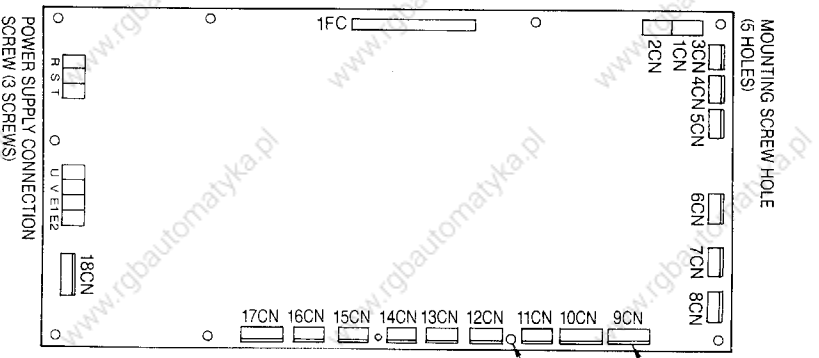

Fig 13.4 Removing Base Driver



(c) 18.5 to 22 kW Base Driver



(d) 30 kW Base Driver



(e) How to Remove Connector

Fig 13.4 Removing Base Driver (Cont'd)

14. TROUBLESHOOTING

If the VS-626MTIII malfunctions, find the cause and take corrective action following Table 14. 1. If any other problem occurs, contact your Yaskawa representative.

Table 14.1

Detection (LED Display)	Condition when Problem Occurs					Probable Cause	Check Method	Corrective Action	
	Power ON	Starting Operation	Stop	Acceleration	Deceleration				Cutting
Overcurrent (LOC)	○			○	○	○	· Defective controller	· Contact Yaskawa representative.	· Replace the controller.
		○					· Main circuit Connection error	· Check the main Circuit wiring.	· Correct the main circuit connection.
							· Load shorting	· Measure the resistance between motor terminals and check for shorts.	· Replace the motor.
							· Ground fault	· Check the short between output terminals and ground of the controller.	· Correct grounding.
							· Defective transistor module	· Check the resistance between terminals of transistor module.	· Replace the transistor module.
			○	○	○		· Wrong setting of control constants	· Verify the control constants by the list of settings for machines.	· Correct the control constants.
MCCB trips. (PEC)	○						· MCCB off	· Check that MCCB is off.	· Turn off the power and turn on the MCCB.
							· Defective controller	· Check that MCCB is on.	· Replace the controller.
							· Defective thyristor module or power transistor module for regenerative circuit.	· Check the resistance of the module.	· Replace the module.
	○		○	○	○		· Open phase in power supply	· Check the voltage between input terminals.	· Repair power supply connections.
Regenerative Overcurrent (EOC)	○				○		· Defective thyristor module or power transistor module for regenerative circuit.	· Check the resistance of the module.	· Replace the module.
					○		· Open phase in power supply; power failure	· Check the voltage between input terminals.	· Repair power supply connections.

Table 14.1 (Cont'd)

Detection (LED Display)	Condition when Problem Occurs						Probable Cause	Check Method	Corrective Action
	Power ON	Starting Operation	Stop	Acceleration	Deceleration	Cutting			
Regenerative Overcurrent (CO) (Cont'd)					○		<ul style="list-style-type: none"> Wrong setting of control constants 	<ul style="list-style-type: none"> Verify the control constants by the list of settings for machines. 	<ul style="list-style-type: none"> Correct the control constants.
							<ul style="list-style-type: none"> Excessive braking torque 	<ul style="list-style-type: none"> Contact Yaskawa representative. 	<ul style="list-style-type: none"> Reduce torque limit level.
	○	○		○		○	<ul style="list-style-type: none"> Defective controller 	<ul style="list-style-type: none"> Contact Yaskawa representative. 	<ul style="list-style-type: none"> Replace the controller.
Overvoltage (OU)					○		<ul style="list-style-type: none"> High supply voltage 	<ul style="list-style-type: none"> Check the voltage between input terminals. 	<ul style="list-style-type: none"> Change the supply voltage within the specified range by changing taps of transformer.
							<ul style="list-style-type: none"> Low supply voltage (due to decrease of regenerative capacity by decrease of supply voltage) 	<ul style="list-style-type: none"> Contact Yaskawa representative. 	<ul style="list-style-type: none"> Reduce the deceleration torque limit level.
							<ul style="list-style-type: none"> Open phase in power supply; power failure. 	<ul style="list-style-type: none"> Check the voltage between input terminals. 	<ul style="list-style-type: none"> Repair power supply connections.
							<ul style="list-style-type: none"> Wrong setting of control constants 	<ul style="list-style-type: none"> Verify the control constants by the list of settings for machines. 	<ul style="list-style-type: none"> Correct the control constants.
							<ul style="list-style-type: none"> Excessive braking torque 	<ul style="list-style-type: none"> Contact Yaskawa representative. 	<ul style="list-style-type: none"> Reduce torque limit level.
	○	○		○	○	○	<ul style="list-style-type: none"> Defective controller 		<ul style="list-style-type: none"> Replace the controller.
Overspeed (OS)		○		○	○	○	<ul style="list-style-type: none"> Improper characteristics of PG cable 	<ul style="list-style-type: none"> Check the specifications of PG cable. 	<ul style="list-style-type: none"> Replace the PG cable (use Fujikura Cable KQVV-SW).
				○		○	<ul style="list-style-type: none"> Wrong setting of control constants. 	<ul style="list-style-type: none"> Verify the control constants by the list of settings for machines. 	<ul style="list-style-type: none"> Correct the control constants.
	○	○	○	○	○	○	<ul style="list-style-type: none"> Defective controller 	<ul style="list-style-type: none"> Contact Yaskawa representative. 	<ul style="list-style-type: none"> Replace the controller
Undervoltage (LU)	○	○	○	○	○	○	<ul style="list-style-type: none"> Large waveform distortion of power supply. 	<ul style="list-style-type: none"> Check the voltage between input terminals. 	<ul style="list-style-type: none"> Repair power supply connections, etc.
							<ul style="list-style-type: none"> Open phase in power supply; power failure. 		

14. TROUBLESHOOTING (Cont'd)

Table 14.1 (Cont'd)

Detection (LED Display)	Condition when Problem Occurs						Probable Cause	Check Method	Corrective Action
	Power ON	Starting Operation	Stop	Acceleration	Deceleration	Cutting			
Undervoltage (UU) (Cont'd)	○	○	○	○	○	○	• Low supply voltage	• Check the voltage between input terminals.	• Change the supply voltage within the specified range by changing taps of transformer.
							• Defective base drive or control circuit board.	• Contact Yaskawa representative.	• Replace the base drive or control circuit board.
Overload (OL)						○	• Motor overload	• Check the load with load meter.	• Reduce the load.
				○	○		• Frequent acceleration/deceleration operation.		• Reduce the frequency of acceleration/deceleration operation.
		○		○			• Main circuit lead broken, wrong connection.	• Check the connection between controller and motor.	• Correct main circuit wiring.
							• PG cable broken, wrong connection.	• Check the PG cable.	• Correct PG cable wiring.
Excessive Speed Deviation (DEU)	○	○	○	○	○	○	• Defective controller.	• Contact Yaskawa representative.	• Replace the controller.
							• Motor overload	• Check the load condition.	• Reduce the load.
						○	• Torque limit operation.	• Check if external torque limit signals (TLL, TLH) are input.	• Release torque limit.
							• Wrong setting of control constants	• Verify the control constants by the list of settings for machines.	• Correct the control constants.
		○		○	○	○	• Main circuit lead broken, wrong connection.	• Check the connection between controller and motor.	• Correct main circuit wiring.
							• PG cable broken, wrong connection.	• Check the PG cable.	• Correct PG cable wiring.
Motor Overheat (OH)							• Defective controller.	• Contact Yaskawa representative.	• Replace the controller.
							• Motor overload	• Check the motor temperature using the setting panel.	• Stop the operation and cool the motor. • Lighten the load.
				○	○	○	• Motor cooling fan stops.	• Check the operation of motor cooling fan. • Check for breaking of cooling fan power lead.	• Replace the cooling fan. • Repair the cooling fan power lead.

Table 14.1 (Cont'd)

Detection (LED Display)	Condition when Problem Occurs						Probable Cause	Check Method	Corrective Action
	Power ON	Starting Operation	Stop	Acceleration	Deceleration	Cutting			
Motor Overheat (OH) (Cont'd)				○	○	○	• Defective motor cooling function.	• Check for coating of dust, oil, etc. in air passage.	• Clean the motor.
	○	○	○	○	○	○	• Thermo detector signal lead shorted.	• Check the wiring of thermistor signal lead.	• Repair the thermo detector signal lead.
							• Defective controller.	Contact your Yaskawa representative.	• Replace the controller.
Motor Temperature Too Low (OHL)	○		○				• Low motor temperature.	• Check the motor ambient temperature.	• Raise the ambient temperature to the specified range.
	○		○	○	○	○	• Thermo detector signal lead shorted.	• Check the motor temperature using the setting panel (Approx. 14°C at lead breaking.)	• Repair the thermo detector signal lead.
Controller Overheat (OHF)							• Controller ambient temperature high	• Check the controller ambient temperature.	• Reduce the temperature within the specified range.
				○	○	○	• Cooling fin dirty.	• Check for coating of dust, cutting oil, etc. on cooling fin.	• Clean the cooling fin.
							• Controller cooling fan stops.	• Check the operation of controller cooling fan.	• Replace the cooling fan or the controller.
Fuse Disconnection (FU)		○		○	○	○	• Fuse disconnection. (Check for the cause referring to overcurrent column)	• Fuse disconnection check.	• Replace fuse
							• Base drive fault (See Par. 8.6)	• Contact your Yaskawa representative.	• Replace base drive board.
PG Signal Fault (PG)		○		○			• PG cable disconnection	• Check wires of PG cable.	• Correct PG wiring
							• Main circuit disconnection.	• Check wiring between controller and motor.	• Correct the main circuit wiring
							• Base drive fault.	• Check fuse in base drive board.	• Replace base drive board
AD Error (Ad, AdC)							• Defective control circuit.	• Turn off the power and after the display on the setting panel is off, return on the power again	• If normal, resume operation.
PG Counter Error (PCC)							• Defective controller.		• If a failure display appears again, replace the controller.
Memory Error (ICP, ICRI, ICRE, ICAN)	○	○	○	○	○	○			
CPF (....)	○	○	○	○	○	○	• Controller fault.	• Contact your Yaskawa representative.	• Replace controller.
Coil Change Error (CHE)	○	○		○	○	○	• Coil change contactor fault.	• Contact your Yaskawa representative.	• Replace contactor.

14. TROUBLESHOOTING (Cont'd)

Table 14.1 (Cont'd)

Detection (LED Display)	Condition when Problem Occurs					Probable Cause	Check Method	Corrective Action
	Power ON	Starting Operation	Stop	Acceleration	Deceleration Cutting			
Motor will not Rotate.						<ul style="list-style-type: none"> Protective function operates. 	<ul style="list-style-type: none"> Check the cause according to the LED display on the setting panel. 	<ul style="list-style-type: none"> Take appropriate corrective actions.
						<ul style="list-style-type: none"> Control fuse blown. 	<ul style="list-style-type: none"> Check for blown fuse. 	<ul style="list-style-type: none"> Replace the control fuse.
						<ul style="list-style-type: none"> Torque limit operation 	<ul style="list-style-type: none"> Check if external torque limit signals (TLL, TLH) are input. 	<ul style="list-style-type: none"> Release torque limit.
		○			○	<ul style="list-style-type: none"> Control signals are not input. 	<ul style="list-style-type: none"> Check the control signal using the setting panel. <ul style="list-style-type: none"> Ready (RDY) Emergency stop (EMG) Forward (FOR) or reverse (REV) running. Speed command (NREF) 	<ul style="list-style-type: none"> Correct the control constants.
						<ul style="list-style-type: none"> Defective base drive circuit board. 	<ul style="list-style-type: none"> Contact Yaskawa representative. 	<ul style="list-style-type: none"> Replace the base drive circuit.
Motor does not Rotate at Reference Speed.						<ul style="list-style-type: none"> Incomplete adjustment of speed. 	<ul style="list-style-type: none"> Check for speed using the setting panel. 	<ul style="list-style-type: none"> Adjust the speed according to par. 11.2.1.
						<ul style="list-style-type: none"> Torque limit operation. 	<ul style="list-style-type: none"> Check if external torque limit signals (TLL, TLH) are input. 	<ul style="list-style-type: none"> Release torque limit.
				○	○	<ul style="list-style-type: none"> Speed command signal error. 	<ul style="list-style-type: none"> Check for speed command (NREF) using the setting panel. 	<ul style="list-style-type: none"> Adjust the speed command voltage.
						<ul style="list-style-type: none"> Wrong setting of control constants. 	<ul style="list-style-type: none"> Verify the control constants by the list of settings for machines. 	<ul style="list-style-type: none"> Correct the control constants.

Table 14.1 (Cont'd)

Detection (LED Display)	Condition when Problem Occurs						Probable Cause	Check Method	Corrective Action
	Power ON	Starting Operation	Stop	Acceleration	Deceleration	Cutting			
Acceleration or Deceleration Time Too Long							<ul style="list-style-type: none"> • Torque limit operation. 	<ul style="list-style-type: none"> • Check if external torque limit signals (TLL, TLH) are input. 	<ul style="list-style-type: none"> • Release torque limit.
							<ul style="list-style-type: none"> • Setting time of soft start too long. 	<ul style="list-style-type: none"> • Check for time of soft start ($t_{\tau-10}$) using the setting panel. 	<ul style="list-style-type: none"> • Change the setting time.
		○		○	○		<ul style="list-style-type: none"> • Abnormal load conditions. 	<ul style="list-style-type: none"> • Check for load conditions with load meter. • Check for loss and GD^2 of load. 	<ul style="list-style-type: none"> • Reduce the load, if necessary.
							<ul style="list-style-type: none"> • Wrong setting of control constants. 	<ul style="list-style-type: none"> • Verify the control constants by the list of settings for machines. 	<ul style="list-style-type: none"> • Correct the control constants.
							<ul style="list-style-type: none"> • Defective controller. 	<ul style="list-style-type: none"> • Contact your Yaskawa representative. 	<ul style="list-style-type: none"> • Replace the controller.
Excessive Motor Vibration or Noise							<ul style="list-style-type: none"> • Improper mounting of motor. 	<ul style="list-style-type: none"> • Check for loose screws, misalignment and imbalance. 	<ul style="list-style-type: none"> • Correct. (Tighten screws, balance coupling, etc.)
							<ul style="list-style-type: none"> • Vibration of load. 	<ul style="list-style-type: none"> • Check for foreign matter, damage or deformation of moving parts of machines. 	<ul style="list-style-type: none"> • Remove foreign matter, repair or replace damaged parts.
		○		○	○	○	<ul style="list-style-type: none"> • Improper characteristics of PG cable. 	<ul style="list-style-type: none"> • Check for the specifications of PG Cable. 	<ul style="list-style-type: none"> • Replace the PG cable.
							<ul style="list-style-type: none"> • Motor or controller not grounded. 	<ul style="list-style-type: none"> • Perform conductive test of grounding. 	<ul style="list-style-type: none"> • Correct grounding cables, terminals, etc. as necessary.
							<ul style="list-style-type: none"> • Main circuit lead broken. 	<ul style="list-style-type: none"> • Check the connection between controller and motor. 	<ul style="list-style-type: none"> • Correct main circuit wiring.
							<ul style="list-style-type: none"> • Speed control gain too high. 	<ul style="list-style-type: none"> • Contact your Yaskawa representative. 	<ul style="list-style-type: none"> • Reduce the speed control gain using the setting panel.
							<ul style="list-style-type: none"> • Defective motor bearing. 		<ul style="list-style-type: none"> • Replace the motor.
						<ul style="list-style-type: none"> • Defective controller. 		<ul style="list-style-type: none"> • Replace the controller. 	

15. SPARE PARTS

Table 15.1 shows the number of pieces of the main parts used in a VS-626MTⅢ controller. At least one set of fuses should be stored.

To order spare parts, refer to Yaskawa Control Co., Ltd.

Table 15.1 Part Quantity Table

Part name		Type	Q'ty Code No.	VS-626 MTⅢ Model							
				3.7 K	5.5 K	7.5 K	11 K	15 K	18.5 K	22 K	30 K
Transistor Module	Main Circuit	6DI-75-050	STR000253	1	1						
		6DI-100-050	STR000254			1					
		2DI-150-050	STR000260				3				9
		2DI-200-050	STR000266					3			
		EVL31-055	STR000143						9	9	
	Regenerative Circuit	QM50E ₂ Y-HD	STR000304	1	1						
		QM50E ₃ Y-HD	STR000305	1	1						
		QM75E ₂ Y-HD	STR000306			1					
		QM75E ₃ Y-HD	STR000307			1					
		QM100E ₂ Y-HD	STR000308				1				
		QM100E ₃ Y-HD	STR000309				1				
		QM150E ₂ Y-HD	STR000310					1			
		QM150E ₃ Y-HD	STR000311					1			
	Thyristor Module	EVK71-050	STR000142						3	3	
EVL32-055		STR000225								3	
MSG60L41A		SCR000242	3	3	3						
MSG100L41		SCR000243				3	3				
Diode Module	TM90DZ-H	SCR000198						3	3		
	TM130DZ-H	SCR000238								3	
Diode Module	RM60C2Z-H	SID000304						4	4	6	
Fuse	DC Circuit	25SH100	FU000697				1				
		25SH125	FU000698					1			
		25SH150	FU000699								
		25SH200	FU000700						1	1	
		25SH260	FU000780								1
	Control Circuit	GTX-5	FU000592	2	2	2	2	2	2	2	2
Cooling Fan*	4715PS-22T-B30-07	FAN000121	1	1							
	5915PC-22T-B30-04	FAN000123			1	1	1				2
	7556MUX	FAN000111						1	1		
Base Driver	JPAC-C342	ETC00858X	1	1	1						
	JPAC-C343	ETC00859X				1	1				
	JPAC-C371	ETC00887X						1	1		
	JPAC-C372	ETC00888X									1
Controller	JPAC-C341	ETC00857X	1	1	1	1	1				
	JPAC-C341-A	ETC50285X					1			1	1
Fower Board	—	ETX00245X	1	1							
	—	ETX00246X			1						
	—	ETX00255X				1	1				
	—	ETX00260X						1	1		
	—	ETX00261X									1

*Only open chassis type

Features of Winding Selection

Winding Selection method is an effective way to expand the constant power range of spindle drives. This method has features as below.

(1) Wide Range Constant Power

Wide range constant power, with a ratio of 1:12, is available without gears.

(2) Small Inverter Capacity

A larger size inverter is required to expand the constant power range with an ordinary methods because motor current increases at low speed range. In this method, a standard size inverter is available to expand a constant power range.

(3) High Control Stability

Winding selection method has both a low speed winding and high speed winding. Each winding is used in each speed range. Therefore, control stability increases as high loop gain can be used.

(4) Magnetic Contactor for Winding Selection.

This magnetic contactor was developed for winding selection and the size is small.

The contact arrangement of this contactor is transfer type and it can be directly driven by the inverter. The mechanical life is more than 5 millions contacts.

16. SPECIFICATIONS

Table 16.1 Standard Specifications

Model		UAASKB-CA1 (Flang-mounted Type)			UAASKB-CA3 (Foot-mounted Type)		
		06	08	11*	15	19	22
Note:	30-minute Rating kW (50% ED) [Current Value]	5.5 [34]	7.5 [47]	11 (11) [68] (65)	15 [88]	18.5 [103]	22 [132]
Output	Continuous Rating kW [Current Value]	3.7 [25]	5.5 [37]	7.5 (7.5) [59] (48)	11 [67]	15 [86]	18.5 [114]
Rated speed	Base Speed r/min	500			500 (600)		400
	Max. Speed r/min	6000			6000 (6000)		4800
Output Torque at Base Speed (Continuous Rated Current)	N·m	70.6	104.9	143.0 (119)	262.2	357.6	441.0
	kgf·m lb·ft	7.21 52.3	10.7 77.6	14.6 (12.2) 105.9 (88.5)	26.7 193.6	36.5 264.6	45.0 326.2
Rotor Inertia (J)	kg·m ² lb·ft ²	0.0725 6.88	0.10 9.49	0.1375 (0.12) 13.1 (11.4)	0.3375 32.1	0.4725 44.9	0.5475 52.0
Overload Capacity		120% of 30-minute rating (50% ED) for 1 minute					
Cooling Fan		Single-phase 200V, 50/60Hz, 220V 50/60Hz, 230V 60Hz					
Insulation		Class F					
Ambient Temperature, Humidity		0 ~ 3 + 40°C 95% RH, max					
Vibration		V 5			V 10		
Noise		75 dB (A) max			80 dB (A) max		
Paint Color		Munsell N 1.5					
Detector		Magnetic encoder					
Approx. Mass	kg [lb]	105 [232]	120 [265]	170 (140) [375] (309)	260 [574]	355 [784]	405 [894]
Applicable Controller ^{Note 2}		CIMR-MTIII-5.5K	CIMR-MTIII-7.5K	CIMR-MTIII-11K	CIMR-MTIII-15K	CIMR-MTIII-18.5K	CIMR-MTIII-22K
Applicable Magnetic Contactor		HV-75AP (Manufactured by Yaskawa Controls Co., Ltd)				HV-150AP2 (Manufactured by Yaskawa Controls Co., Ltd)	

* Values in parentheses are for flange-mounted type.

Notes 1: The rated output is guaranteed when the current is in 3-phase 200V 50/60Hz, 220V 50/60Hz, or 230V 60Hz.

For input power voltage below 200V, the rated output may not be obtained, even if the voltage is within the permissible range.

2: The controller ROM memory must be of the coil switchover type.

17. CHARACTERISTICS

17.1 OUTPUT POWER, TORQUE VS MOTOR SPEED

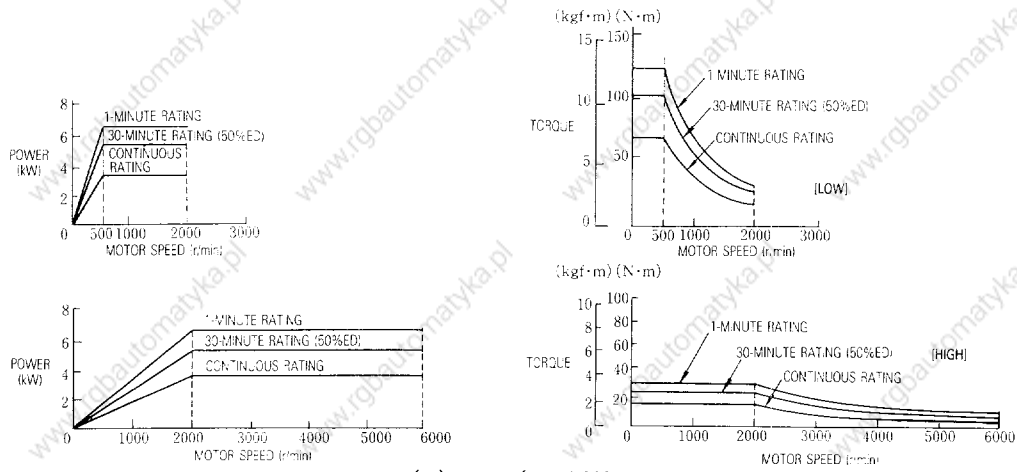

(a) 5.5/3.7 kW

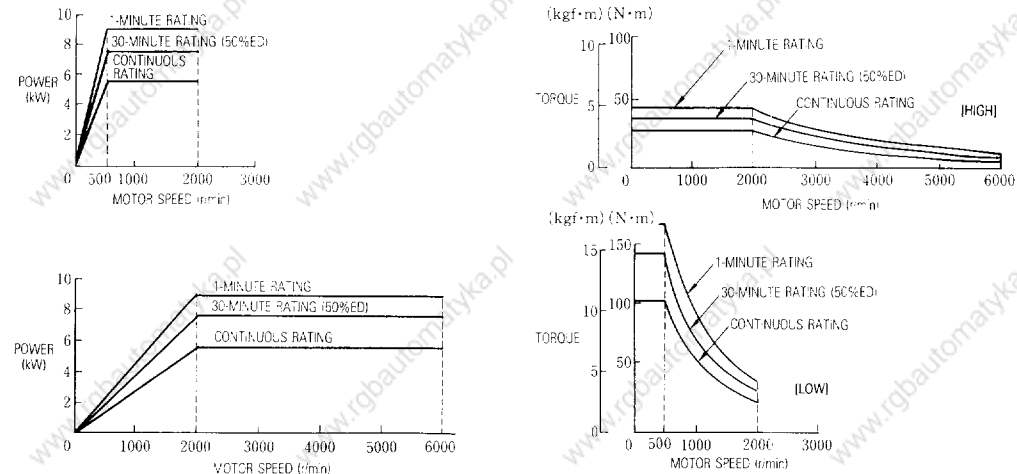

(b) 7.5/5.5 kW

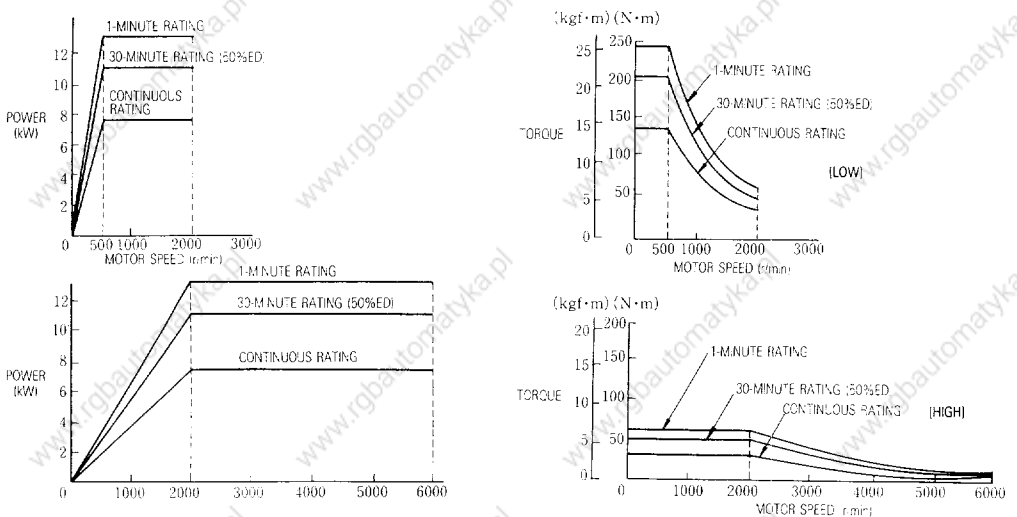

(c) 11/7.5kW (Foot-Mounted Type)

Fig 17.1 Output Power, Torque vs Motor Speed

17.1 OUTPUT POWER, TORQUE VS MOTOR SPEED (Cont'd)

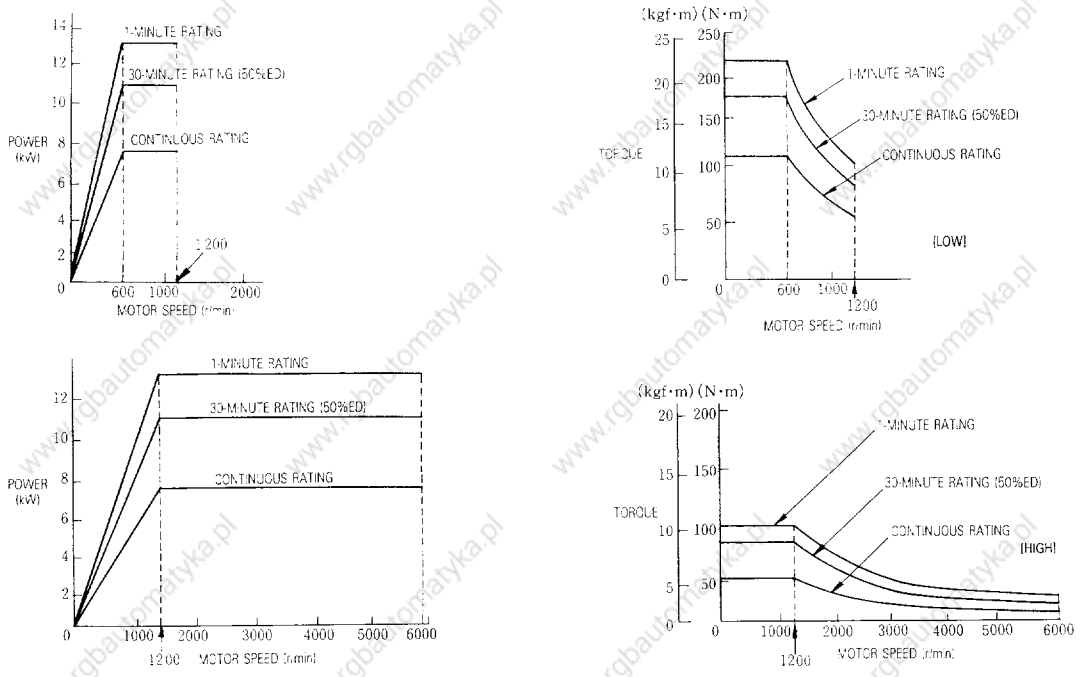

(d) 11/7.5 kW (Flange-Mounted Type)

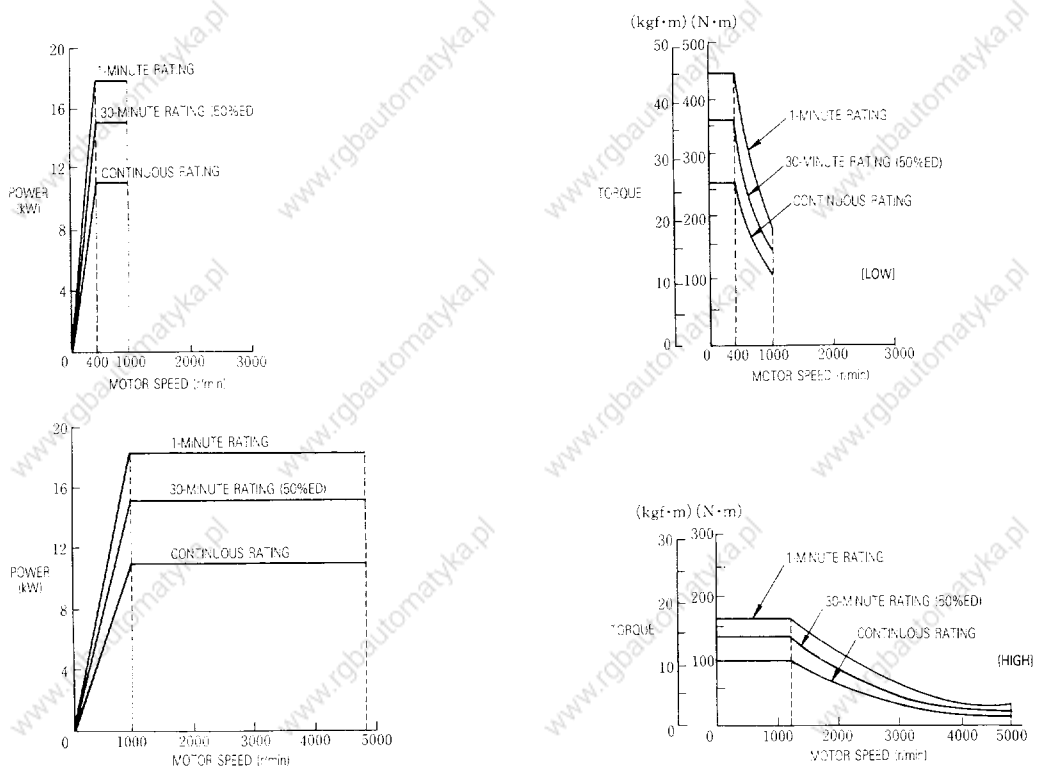

(e) 15/11 kW

Fig. 17.1 Output Power, Torque vs Motor Speed (Cont'd)

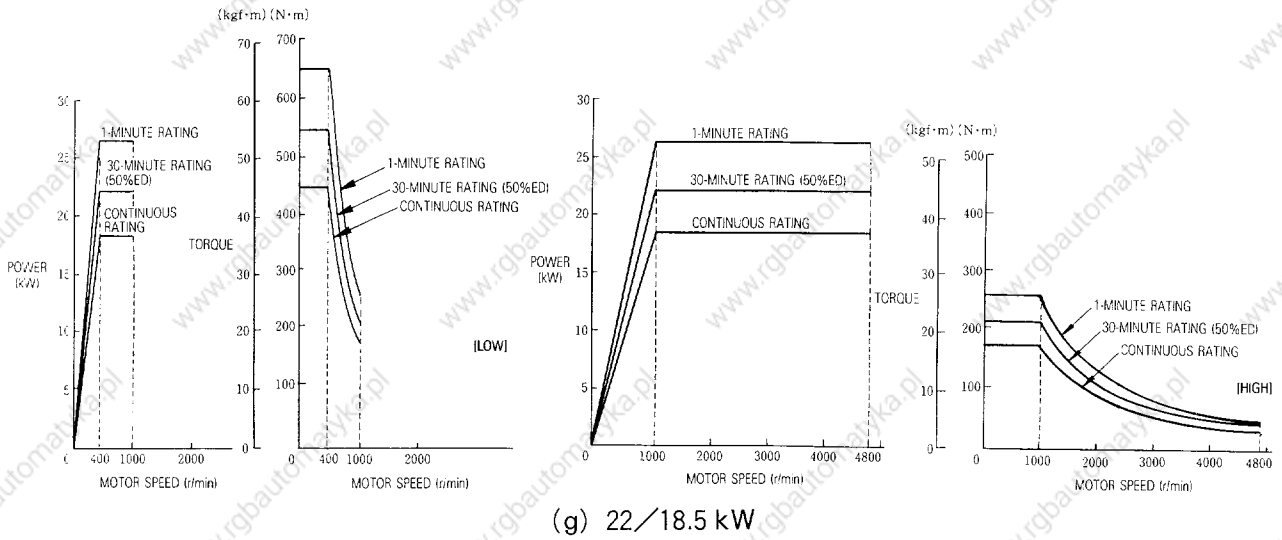
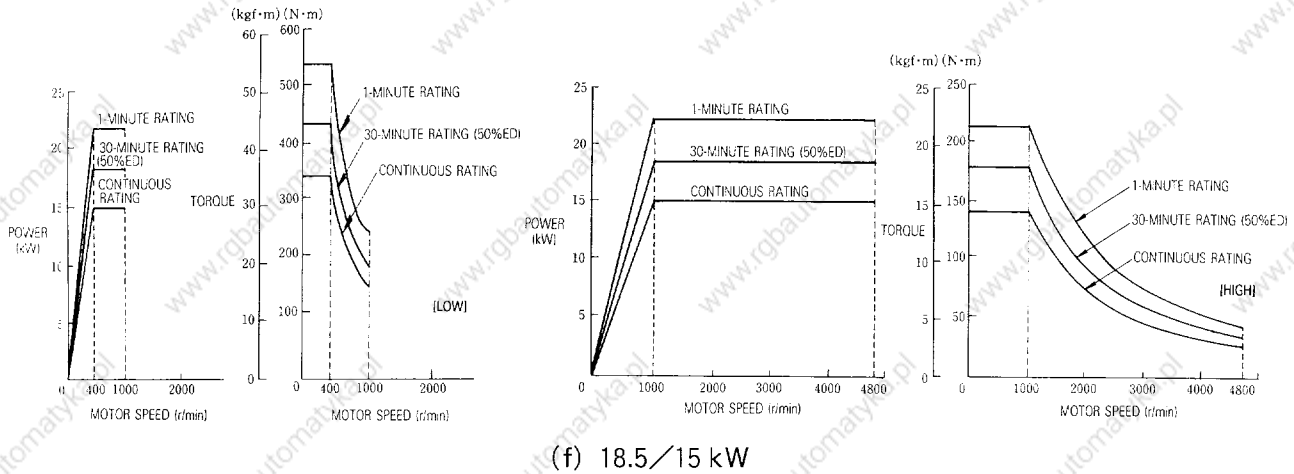

Fig. 17.1 Output Power, Torque vs Motor Speed (Cont'd)

17.2 MOTOR MECHANICAL SPECIFICATIONS

Maximum shaft radial load of each motor is shown in Table 17.1. Load point is at shaft end.

Table 17.1 Max shaft radial load

Motor Model	UAASKB					
	06 CA	08 CA	11 CA	15 CA	19 CA	22 CA
Rated Output Power (30 min/cont.)	5.5/3.7 kW	7.5/5.5 kW	11/7.5 kW	15/11 kW	18.5/5 kW	22/18.5 kW
Radial Load	270 kg			450 kg		

18.2 AC SPINDLE MOTOR MOUNTING CONDITIONS

When mounting the AC main spindle motor, observe the following:

(1) Mounting Location

- Ensure that there is adequate air flow to and from the cooling fan. Provide at least 100 mm space on the motor rear (exhaust side).
- Ensure that no cutting fluid splashes directly on the motor.
- Ensure that the bed, foundation and base, which are subject to dynamic loads, in addition to the motor weight, are sufficiently sturdy to prevent vibration.

(2) Mounting orientation

- Mount the motor on the floor with the foot down.

(3) Linking with machine

- To install belts, align the motor shaft and machine shaft parallel, and direct the shafts perpendicular to the line connecting the two pulleys.
- Since the motor runs at high speeds, even a slight imbalance causes vibration. Be sure to balance the pulley, etc. carefully.

19.2 CONNECTORS

WINDING SELECTION END SIGNAL																SPEED DETECTION SIGNAL			
50	49	48	47	46	45	44	43	42	41	40	39	38	37	36	35	34	33		
LM	OV	OV	SM	ZSPD C	NO	C	NC	NO	COM 1	CHWE	ORE	IP	TLE	TDET	NDET	AGR	ZSPD		
			32	31	30	29	28	27	26	25	24	23	22	21	20	19			
			OV	OV	OV	OV	OV	AC3	AC2	COM2	AC1	ACO	OV	OV	OV	OV			
18	17	16	15	14	13	12	11	10	9	8	7	6	5	4	3	2	1		
MGR	LGR	ORT	PPI	CHW	RST	SSC	TLL	TLH	REV	FOR	EMG	RDY	DAS	OV	NCOM	SS	+15V		

WINDING SELECTION
COMMAND

PCB Side; MR-50 RMAG
Cable Side MR-50 LF(G) or MR-50 LWF(G)

(a) Controller 1 CN

20	19	18	17	16	15	14
FG	*PCB	PCB	*PCA	PCA	*PCC	PCC
13	12	11	10	9	8	
CA2	CA1	CC	-24V	THSB	THSA	
7	6	5	4	3	2	1
SS	+5V	+5V	+5V	OV	OV	OV

PCB Side; MR-20RMAG
Cable Side MR-20 LF(G)
or
MR-20 LWF(G)

(b) Controller 3CN

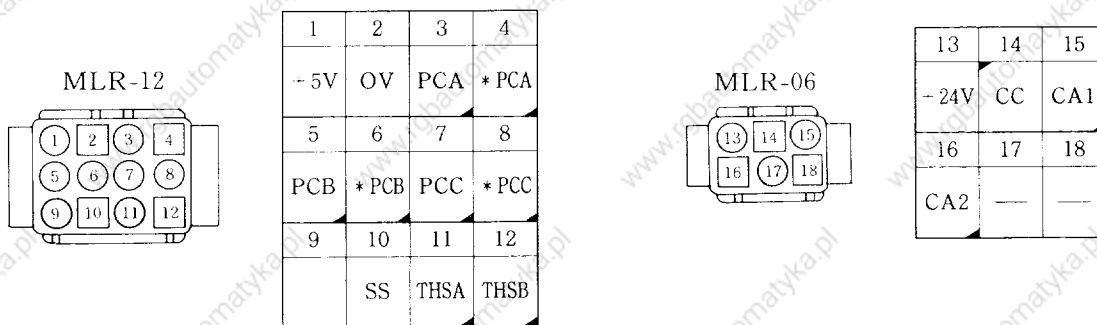

(c) Motor Connector



- Note : 1. The layout of pins is for the case where the connectors on the circuit board are viewed from the fitted part.
2. In the diagram, the symbol  represents an input signal and  an output signal.

Fig. 19.2 Connector Pin Location

20. CONTROL SIGNALS

I/O signals used for motor winding selection control must be in accordance with Par. 5.1 "SEQUENCE INPUT SIGNAL" and Par. 5.3 "SEQUENCE OUTPUT SIGNAL".

Table 20.1 Input/Output Signal

Signal	Connector No.	Pin No.	Level	Function
<p>Motor Winding Selection</p> <p>CHW</p> <p>Input Signal</p>	1 CN	14		<p>Close: Low Speed Winding Open: High Speed Winding</p> <p>CHW is available while EMG is closed. When EHG is open, CHW is unavailable, therefore, current winding is used continuously.</p> <p>Inverter is commanded as coasting stop until motor winding selection is completed once CHW comes to inverter.</p> <p>When actual winding is different from CHW signal at power ON, winding of CHW is selected automatically.</p> <p>Do not use this function while in position control loop, such as orientation operation.</p>
<p>Motor Winding Selection Completion</p> <p>Output Signal</p>	1 CN		Close	<p>This output is open while motor winding is changed.</p> <p>Prepare external circuit to detect winding change alarm which CHWE is not output within setting time after CHW comes to inverter.</p> <p>When the function is used in AGR condition which is speed coincidence, AGR signal is opened.</p>

VS - 626 MT III Standard Constant Settings (Winding Selection Type)

Applied PROM Software No. : NSN 01 × × ×

£ - No.	Code	Lower Limit	Upper Limit	Unit	Motor 5.5/3.7 kW Controller 5.5/3.7 kW	Motor 7.5/5.5 kW Controller 7.5/5.5 kW	Motor (foot-mounted type) 11/7.5kW Controller 11/7.5kW	Motor (flange-mounted type) 11/7.5kW Controller 11/7.5 kW	Motor 15/11 kW Controller 15/11 kW	Motor 18.5/15 kW Controller 18.5/15 kW
1	PNORH	1.00	100.00		30	30	30	20	30	30
2	PNORL	1.00	100.00		30	30	30	20	30	30
3	PORTH	1.00	100.00		30	30	30	30	30	30
4	PORTL	1.00	100.00		30	30	30	30	30	30
5	NADJ	0.9000	1.5600		1	1	1	1	1	1
6	SMADJ	0.90	1.50		1	1	1	1	1	1
7	LMADJ	0.90	1.10		1	1	1	1	1	1
8	LMFS	120	350	%	200	200	200	200	200	200
9	EXTLIM	5	150	%	5	5	5	5	5	5
10	TSPS	0.1	30.0	s	0.1	0.1	0.1	0.1	0.1	0.1
11	EMGTIM	1	15	s	10	10	10	10	10	10
12	INORH	100	1000	ms	600	600	600	600	600	600
13	INORL	100	1000	ms	600	600	600	600	600	600
14	IORTH	10	1000	ms	200 (50)	200 (50)	200 (50)	200 (50)	200 (50)	200 (50)
15	IORTL	10	1000	ms	200 (50)	200 (50)	200 (50)	200 (50)	200 (50)	200 (50)
16	NDETL	0	100	%	29	29	29	10	21	21
17	DNDTL	0.00	10.00	%	1	1	1	1	1.3	1
18	TDETL	5	120	%	30	30	30	30	30	30
19	PTAP	1.00	100.00		20	20	20	20	20	30
20	ITAP	50	1000	ms	100	100	100	100	100	100
21	N 100	3500	MAX RPM	r/min	6000	6000	6000	6000	4800	4800
22	HGEAR	0.05	1.50		1.0	1.0	1.0	1.0	1.0	1.00
23	MGEAR	0.05	1.50		0.6	0.6	0.6	0.6	0.6	0.60
24	LGEAR	0.05	1.50		0.2	0.2	0.2	0.2	0.2	0.20
25	MOTOR	0000	00 FF		0039	0033	0036	0038	0031	0044
26	SELCD 1	0000	FFFF		06 A 4	06 A 4	06 A 4	02 A 4	06 A 4	02 A 4
27	SELCD 2	0000	FFFF		0007	0007	0007	0007	0007	0007
28	ACCTLI	50	150	%	120	120	120	120	125	120
29	DECTLI	50	150	%	120	120	120	120	125	120
30	DI 2 LIM	1.0	20.0	ms	1.0	1.0	1.0	1.0	1.0	1.0
31	IWLVL	15	100	%	30	30	30	30	30	30
32	IWGAIN	25	50	%	30	30	30	30	30	30
33	PHAIWE	15	100	%	70	70	70	50	70	70
34	PHAILM	60	120	%	100	100	100	100	100	100
35	PHITAP	50	100	%	70	70	70	70	70	70
36	CNBTAP	1.00	3.00		1.0	1.0	1.0	2.0	1.0	1.0
37	NORT	1.00	5.00	V	2.5	2.5	2.5	2.5	2.5	2.5
38	NCRP	0.05	2.00	V	0.2	0.2	0.2	0.2	0.2	0.2
39	AGREE	10	50	%	15	15	15	15	15	15
40	OFFSET	-10.00	10.00	%	Individually set	Individually set	Individually set	Individually set	Individually set	Individually set
Applied Controller Code No.					ETC 00857 X	ETC 50285 X	ETC 50285 X	ETC 00857 X	ETC 00857 X	ETC 00857 X

Note: () indicates the settings for models with encoder type spindle orientation.

21. OPERATION

21.1 MOTOR CHARACTERISTICS

This Motor has both low speed windings and high speed windings with a constant horse-power range of 1:12 for each winding of 1:4, as follows.

$$\frac{N_{ML}}{N_{BL}} = \frac{N_{MH}}{N_{BH}} = 4$$

Also base speed ratio and maximum speed ratio between low speed winding and high speed winding are designed to obtain the best motor characteristics follows.

$$\frac{N_{BH}}{N_{BL}} = \frac{N_{MH}}{N_{ML}} = 3$$

Motor winding is switched between N_{BH} and N_{ML} because both windings can generate the rated power of the motor between N_{BH} and N_{ML} .

Indications of Load meter of each winding include $\pm 10\%$ error when each winding generates the same power between N_{BH} and N_{ML} .

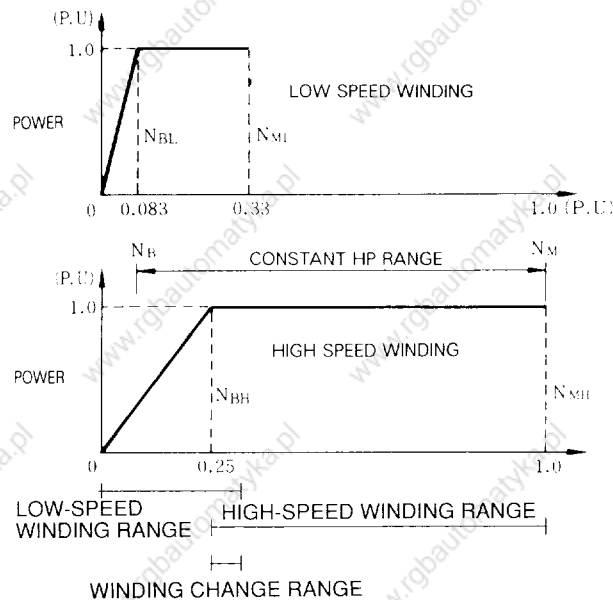

Do not use the low speed winding at speeds more than N_{ML} because motor characteristics are not guaranteed.

Fig. 21.1 Motor Output Characteristics

21.2 WINDING SELECTION OPERATION

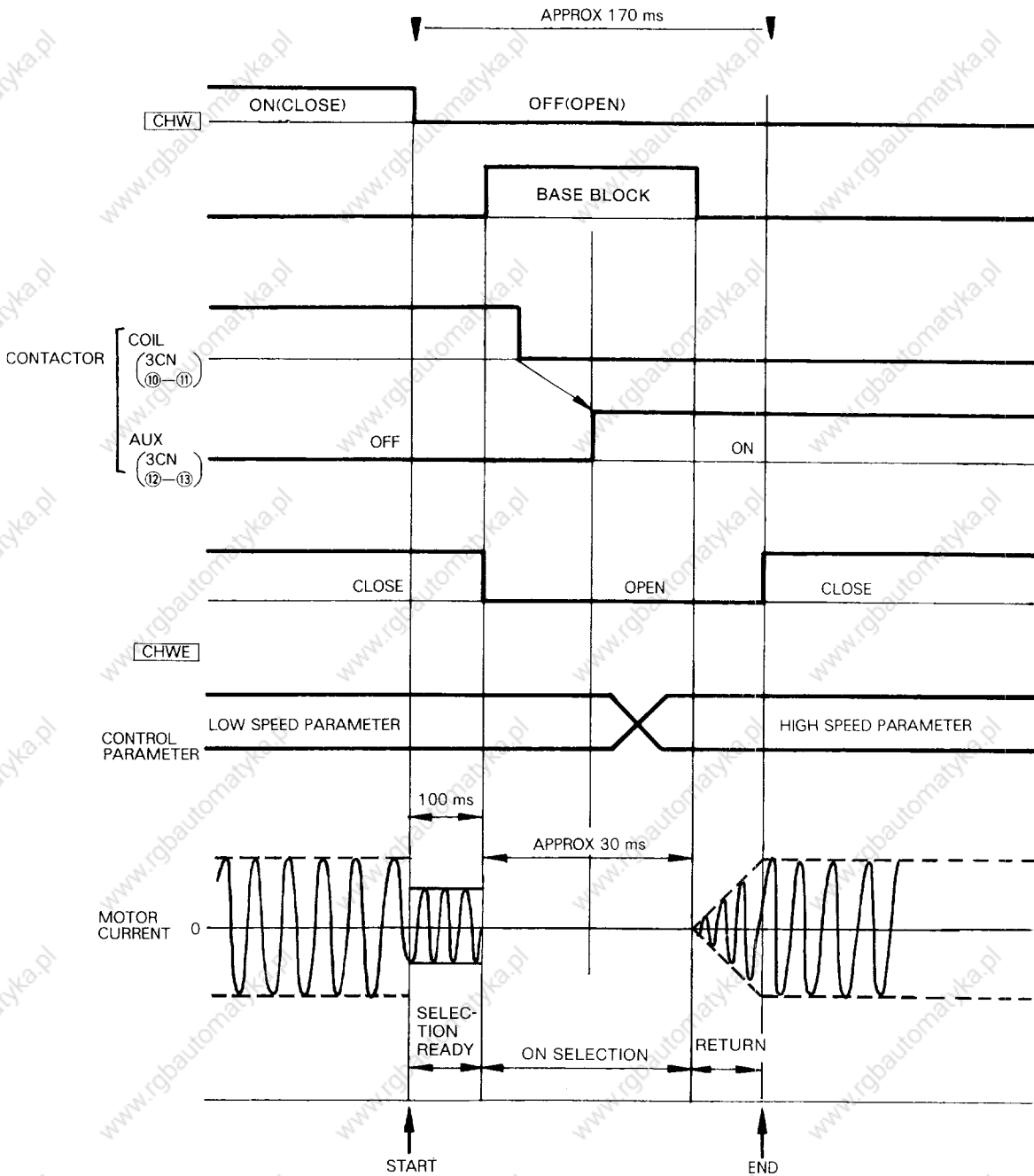

Fig. 21.2 Winding Selection Timing Chart

21.3 WINDING SELECTION PROCEDURES

Two methods of winding change procedures are described below. Refer to these ways when designing a sequence circuit of winding change.

21.3.1 M-code Method

Winding can be changed by using M-code. M41 is a low speed winding and M42 is a high speed winding. Flow chart is shown in Fig. 21.3 and timing chart is shown in Fig. 21.4.

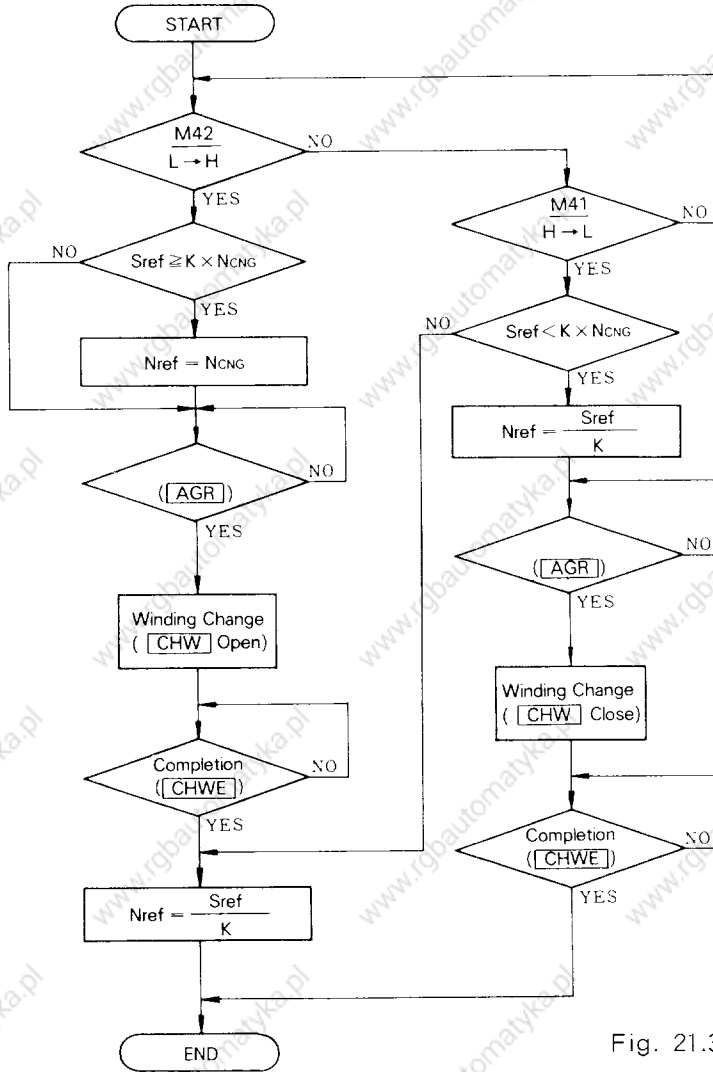

L : Low Speed
 H : High Speed
 M41: Low Speed Winding
 M42: High Speed Winding
 Sref: Spindle Speed Reference
 Ncng: Threshold Speed
 ($N_{BH} \leq N_{cng} \leq N_{ML}$)
 K : Gear Ratio
 [K is 0.8 when spindle speed is
 4000 r/min and Motor Speed is 5000 r/min]
 Nref: Motor Speed Reference

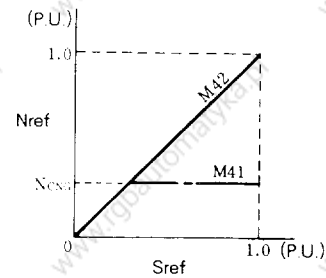

Fig. 21.3 Flow Chart

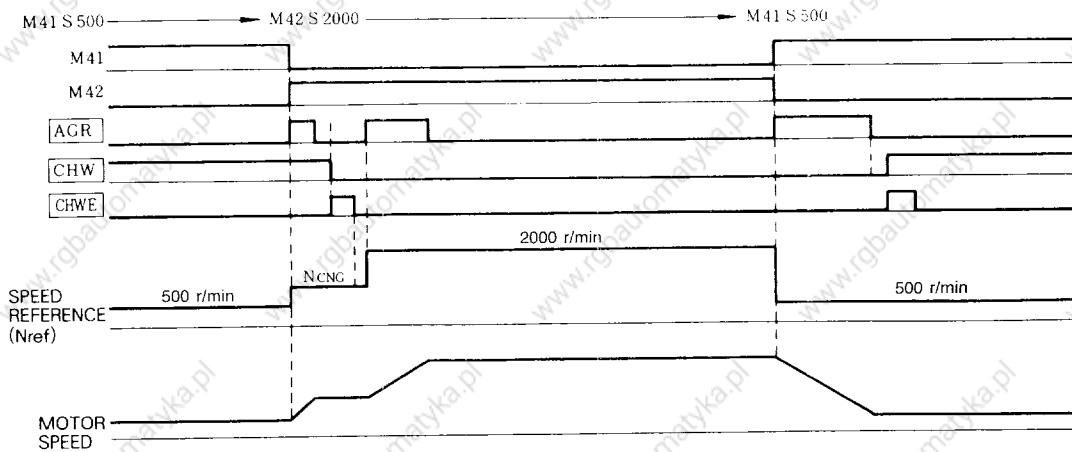

Fig. 21.4 Timing Chart

21. 3. 2 Auto Winding Change Method

Motor winding is automatically switched by using a speed detect signal [NDET] and watching the actual motor speed. Flow chart is shown in Fig. 21.5 and timing chart in Fig. 21.6.

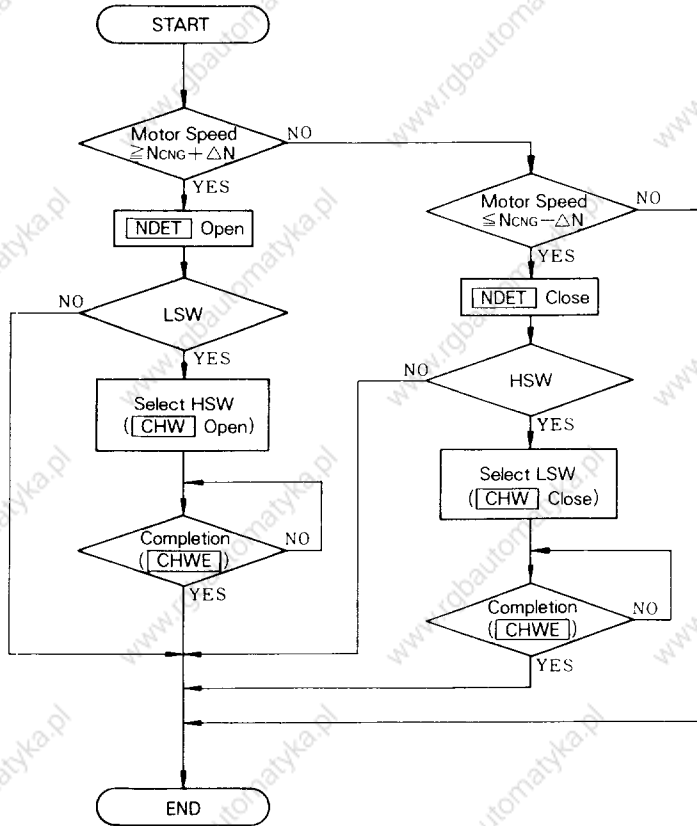

Fig. 21.5 Flow Chart

LSW : Low Speed Winding

HSW : High Speed Winding

N_{CNG} : Threshold Speed

[Set Cn-16 of Control Parameter]

ΔN : Band width of N_{CNG}
[Set Cn-17 of Control Parameter]

Setting value of Cn-16 and Cn-17 under Fig. are calculated as below.

$$N_{CNG} - \Delta N \geq N_{BH}$$

$$N_{CNG} + \Delta N \leq N_{HL}$$

$$Cn-16 = \frac{N_{CNG}}{N_{100}} \times 100 \%$$

$$Cn-17 = \frac{\Delta N}{N_{100}} \times 100$$

[N_{100} is Cn-21
 ΔN is from 100 through 200 r/min]

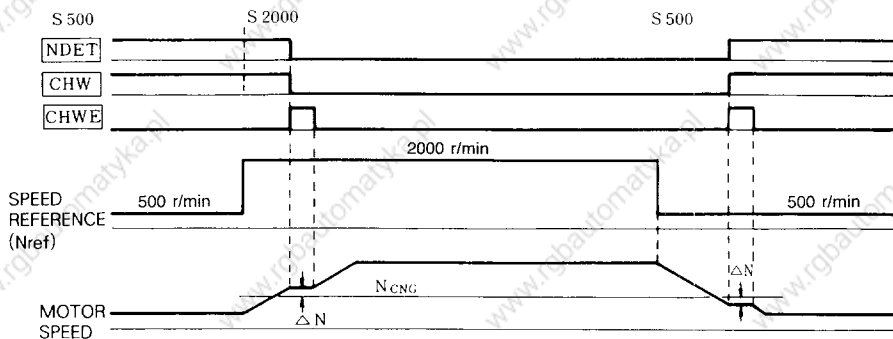
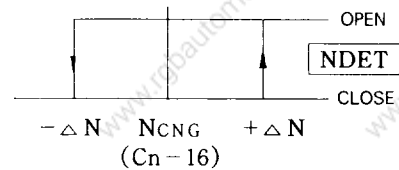
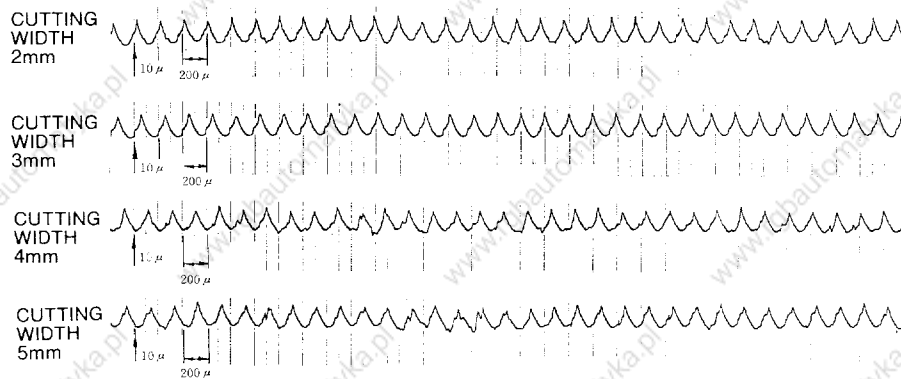

Fig. 21.6 Timing Chart

21.4 NOTES

- If the magnetic contactor for motor winding selection is damaged or the signal leads are disconnected, the spindle stops and operation program does not proceed.
Check time and output alarm signal by using motor winding selection signal and motor winding selection completion signal to inform worker of this condition.
- The frequency of operation of magnetic contactor for motor winding selection increases with this method, because motor winding is switched whenever actual motor speed exceeds N_{CNG} Which is threshold speed.
- Automatic winding selection is performed when the selection speed is reached even during cutting. As shown in Fig. 21.7, some roughness is seen in rough-cutting, however, the closer to finishing, the smaller the error becomes. Therefore, sufficient characteristics can be obtained for actual application. When further accuracy is required, check cutting face accuracy.



(a) Cutting Face Accuracy

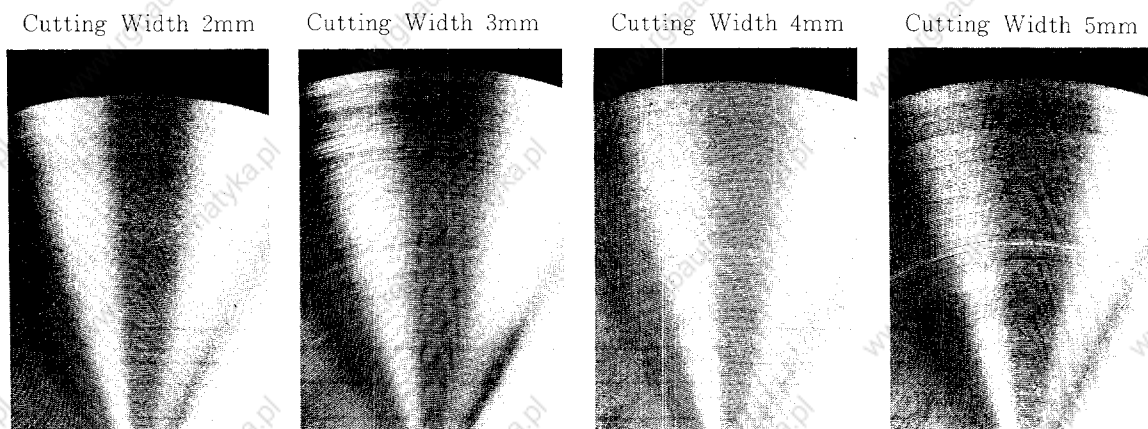

(b) Cutting Face State

Test conditions

- Workpiece : S45C ($\phi 100$ rounded bar)
- Bite : Super hard bite
- Cutting speed : $150\text{m}/\text{min}$
- Feeding : $0.2\text{mm}/\text{rev}$

Fig 21.7 Face Accuracy Data at End Face Cutting by Lathe

22. MAGNETIC CONTACTOR FOR WINDING SELECTION

22.1 RATING AND SPECIFICATIONS

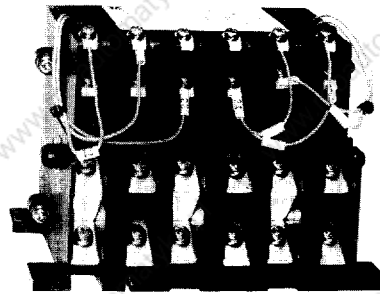

HV - 75 AP 2

688 - 42

Table 22.1 Standard Specification

Model No.	HV-75AP	HV-150AP2
Contact Arrangement	Main 3NO 3NC Aux 1NO	
Rated Isolation Voltage	600V	
Rated Operational Current	75A (Cont.) 87A (30min, 33%ED)	150A (Cont.), 175A (30min, 33%ED)
Maximum Braking Current	200A	400A
Maximum Operational Frequency	600 operations/hour	
Mechanical Life	5,000,000 operations	
Rated Operational Voltage	200V 50/60Hz, 220V 50/60Hz, 230V 60Hz	
Weight	2.5kg	5.0kg
Ambient Temperature	-10 to +55°C	
Humidity	10 ~ 95% RH (non-condensing)	

22.2 DIMENSIONS (in mm)

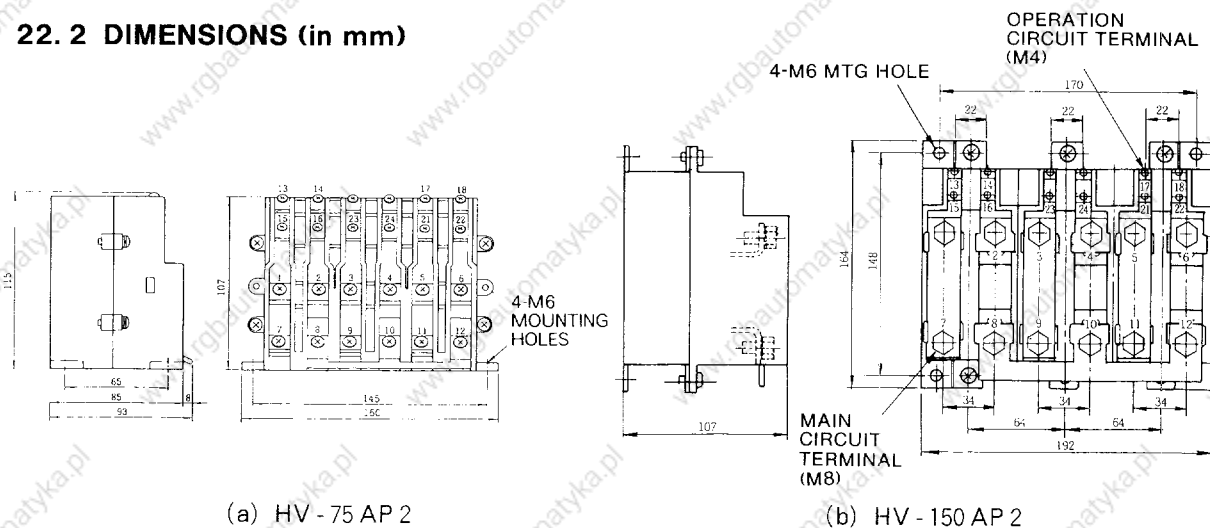

(a) HV - 75 AP 2

(b) HV - 150 AP 2

Fig. 22.1 Dimension Diagram

22.3 OPERATION

Table 22.2 Operation

Operation ⑬-⑭	Main Contacts						Aux ⑮-⑯
	①-②	③-④	⑤-⑥	⑦-⑧	⑨-⑩	⑪-⑫	
+24V	Open			Close			Open
0V	Close			Open			Close

23. TROUBLESHOOTING

If VS-626MTIII malfunctions, find the cause and take corrective action in the following Table in addition to Table 14.1.

Table 23.1 Causes and Check

Problem	Condition when Problem Occurs					Problem Cause	Check Method	Corrective Action
	Start	Stop	Acceleration	Deceleration	Winding change			
Overcurrent (IOC)				○		Deceleration from motor speed more than N_{M1} with low speed winding	Check winding selection command and Speed reference.	Changes sequence for winding selection.
Regenerative Overcurrent (COC)						Wrong connection of motor main circuit	Check connection.	Correct connection of main circuit.
Overvoltage (OV)	○		○	○	○	Bad magnetic contactor for winding selection	Check conduction of main contacts.	Replace magnetic contactor.
Motor does not rotate.	○					No power supply for MC	Check the voltage between ⑰ and ⑱ of MC.	Connect cable to MC.
						Wrong connection or disconnection of MC signal leads	Check connection.	Correct connection.
						Bad magnetic contactor	Check magnetic contactor.	Replace magnetic contactor.
						Wrong connection or disconnection of main circuit cable	Check connection	Correct connection.
Winding Selection does not Complete. { Motor coasts to stop. }			○	○	○	No power supply for MC	Check the voltage between ⑰ and ⑱ of MC.	Connect cable to MC.
						Wrong connection or disconnection of MC signal leads	Check connection.	Correct connection.
						Bad magnetic contactor	Check magnetic contactor.	Replace magnetic contactor.
Large Vibration and Noise { Abnormal Indication of Load Meter }	○		○	○	○	Wrong connection of main circuit cable	Check connection.	Correct connection.
						Bad magnetic contactor	Check conduction of main contactor.	Replace magnetic contactor.

Magnetic Sensor Type Spindle Orientation

Magnetic sensor type spindle orientation system is used to stop the machine tool spindle at a specified position by an electrical method. This system has the following features:

(1) Simple mechanism

The spindle specified position stop functions are accomplished just by mounting a magnetic unit on the spindle and a magnetic sensor on the stationary member.

(2) Short orientation time

The position detection signal from the magnetic sensor forms a servo loop for accurate positioning in a short period of time even when the spindle is running at maximum speed.

(3) Reliability and service life improvement

Substantial reduction of positioning shock leads to higher reliability and longer service life.

(4) Economical advantage

Simplified mechanism and power control sequence make for substantial reduction in cost.

24. SPECIFICATIONS

24.1 SPINDLE ORIENTATION SPECIFICATIONS

Table 24.1 Standard Specifications

Item	Function
Position Detection Mode	Displacement detection based on the detection of magnetic flux generated by a magneto and a magnetic sensor.
Stop Position*	Position corresponding to the center-to-center alignment of the magneto body and the magnetic sensor head. Adjustable within $\pm 1^\circ$ with a potentiometer.
Accuracy of Stop Position Repeating*	$\pm 0.2^\circ$ or below
Reaction Torque*	Continuous rated torque / $\pm 0.1^\circ$ displacement †
Orientation Card	Type JPAC-C345
Magneto	Types MG-137BS (standard) or MG-4555S
Magnetic Sensor	Types FS-1378C (standard) or FS-200A

*When the magneto body is mounted on a 120mm diameter outer surface, excluding mechanical error and error caused by external magnetic fields.

† Reaction torque may be reach continuous rated torque on the setting method of gain.

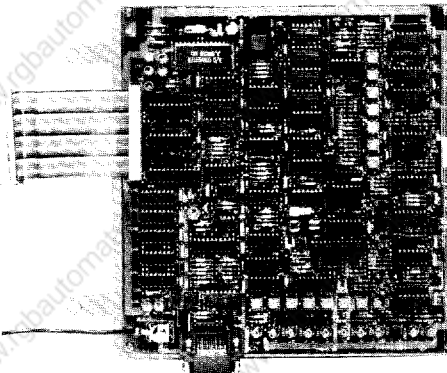

24. 2 DETECTOR SPECIFICATIONS

Table 24. 2 Magnetic Sensor Specifications

Item		Specifications	
		FS-1378C	FS-200A
Power Supply	Voltage	15VDC \pm 5%	12 VDC \pm 10%
	Current	100 mA max	50 mA max
Output	Position Signal (level) (for control) (offset) (output impedance)	\pm 4 V min. \pm 0.2 V max 1.5 k Ω	\pm 8 V min. \pm 0.2 V max 1.5 k Ω
	Position Signal (range) (for monitor) (offset)	30° min.* (+2.4 V min.) \pm 0.5 V max	
Service Temperature Range		-10°C to +50°C	
Output Terminal		With round connector (Made by Tajimi Musen Denki K.K.) (Terminal arrangement) A: Position signal + B: SG C: +15 V D: Position signal - E: Range signal - F: Range signal +	With 5 meter cable 6 mm dia, 4-core rubber-sheathed cable [Wiring] Red: +12 V Black: SG Green: Output + White: Output -
Maker		MAKOME Corporation	

*When magneto is mounted on 120 mm dia. outer surface on spindle.

Table 24. 3 Magneto Specifications

Item	Specifications	
	MG-1378BS	MG-1444S
Detection Range mm (inches)	\pm 15 (\pm 0.59)	\pm 7 (\pm 0.28)
Allowable Speed r/min (Mounted on 200 mm dia. outer surface)	6700	10000
Mass g (lb)	33 (0.073)	14.8 (0.033)
Maker	Makome Corporation	

25. SYSTEM CONFIGURATION

The spindle orientation system is composed of spindle AC motor, a VS-626MT III controller, an orientation card, a spindle position detector magneto and a magnetic sensor. See Fig. 25.1.

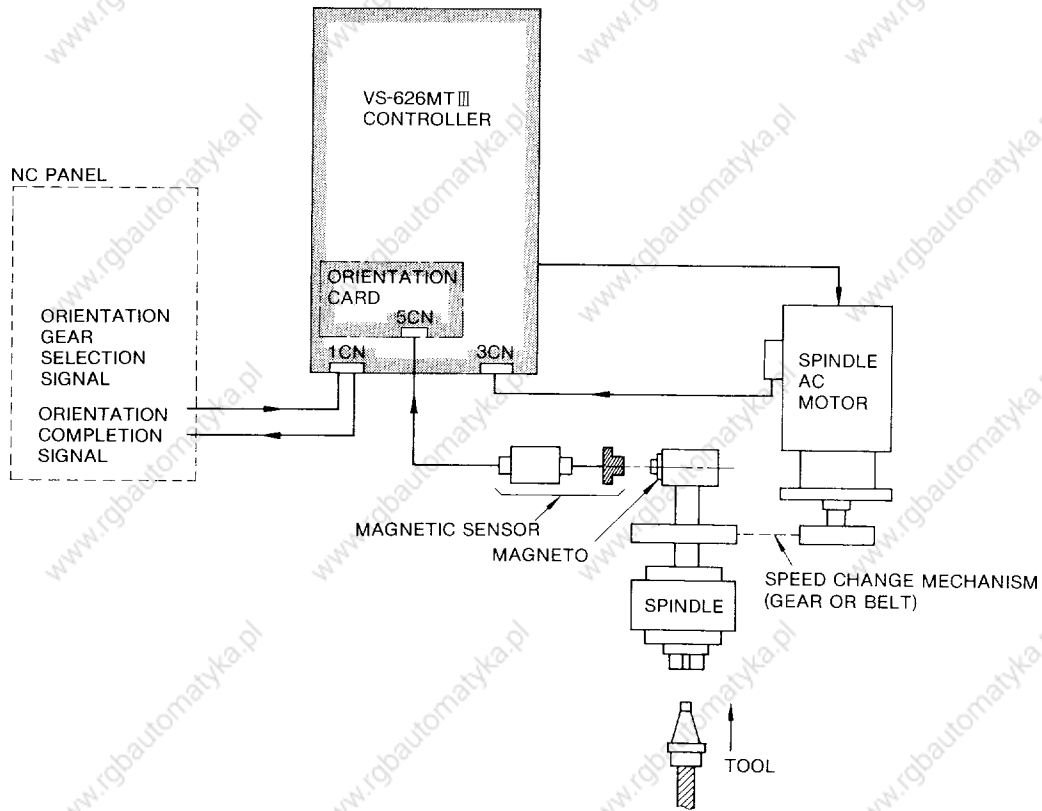

Fig. 25.1 Spindle Orientation System Configuration

26. OUTLINE OF OPERATION

26.1 ORIENTATION CONTROL

Fig. 26.1 is an outline of the orientation control.

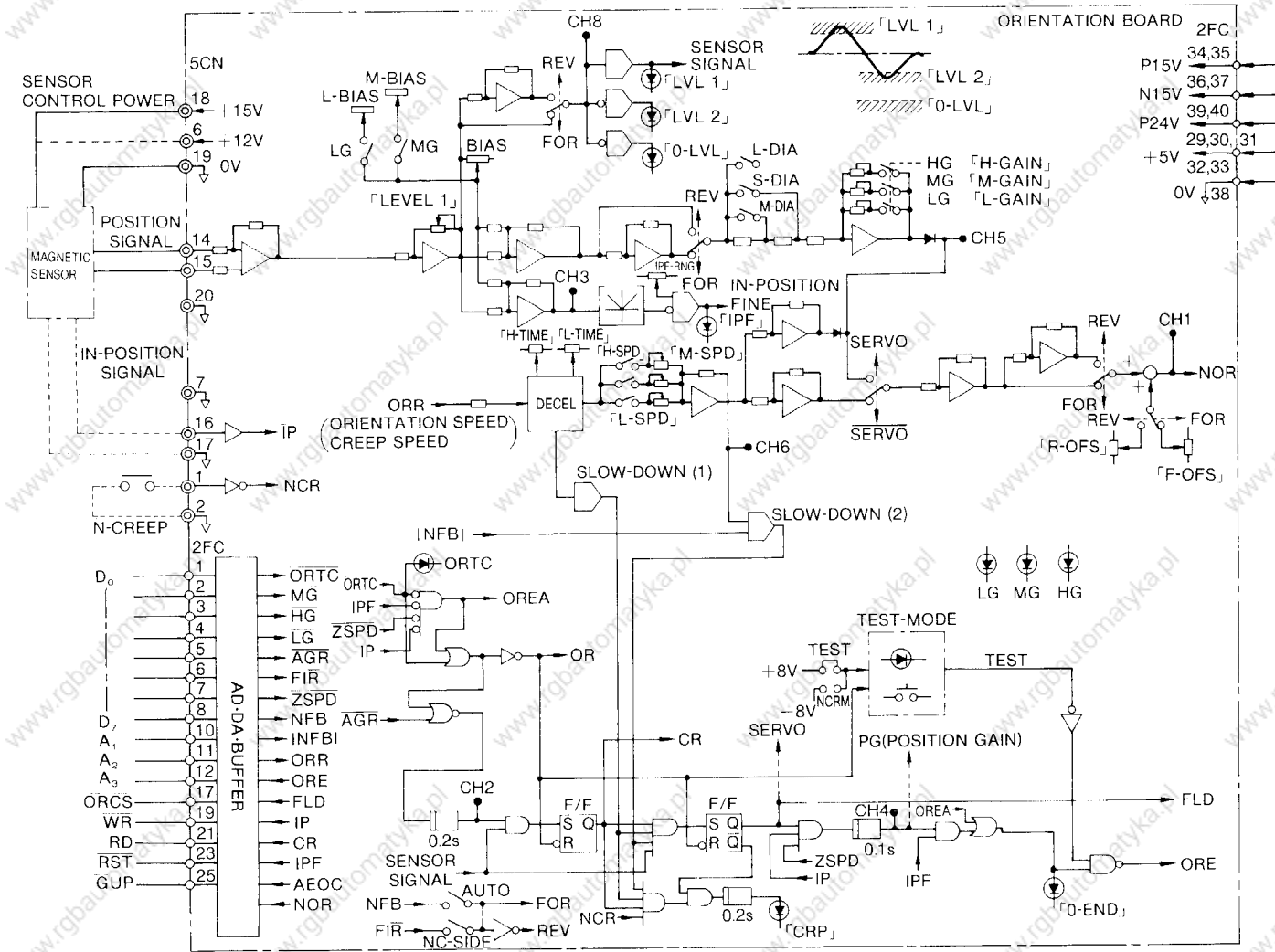

Fig. 26.1 Outline of Orientation Control

26.2 ORIENTATION OPERATION

The VS-626MTIII has two operating modes: the normal mode in which the spindle is controlled by external orientation signals, and the test mode in which the spindle is controlled by card test signals for adjustment.

26.2.1 Normal Mode

When an orientation signal is received while the spindle is in motion (or standing still), the spindle immediately decelerates (or accelerates) to the preset orientation speed.

When the spindle passes the target stop position first time after attaining the preset speed, the soft start function incorporated in the orientation card is started, and the spindle is first decelerated to the preset creep speed, and then, as the magneto comes into alignment with the magnetic sensor, it is stopped by the servo loop.

Thereupon, the O-END LED (green) lights, and an ORE signal is output (contact CLOSE).

After stopping at the specified angular position, the spindle is under control to remain in the position until the command is cleared, so that it resists any external force exerted to displace it from the stop position.

Fig. 26.2 shows the time chart for normal mode orientation operation.

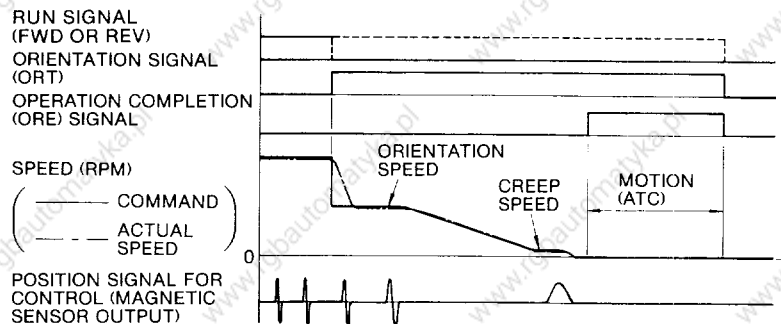

(a) Orientation when Spindle is Running

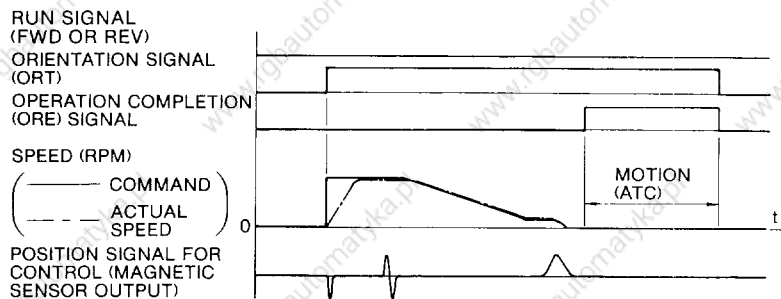

(b) Orientation when Spindle is at Standstill

Fig. 26.2 Time Chart for Normal Mode Orientation

26. 2. 2 Test Mode

When the selection connector on the orientation card (JPAC-C345) is connected in the test mode, the LED (red) built into the test button [TPB] lights.

With ORT (orientation signal) input, when TPB is pushed, the spindle starts to run at the orientation speed. When the spindle passes the stop position for the first time after TPB is released, the spindle stopping sequence, same as in the normal mode, is started to shortly stop the spindle at the specified angular position.

Upon stopping the spindle, the O-END LED (green) lights, but no ORE signal is output, so that the spindle can be repeatedly tested for the orientation motion with the TPB button.

Fig. 26.3 shows the time chart for the test mode orientation operation.

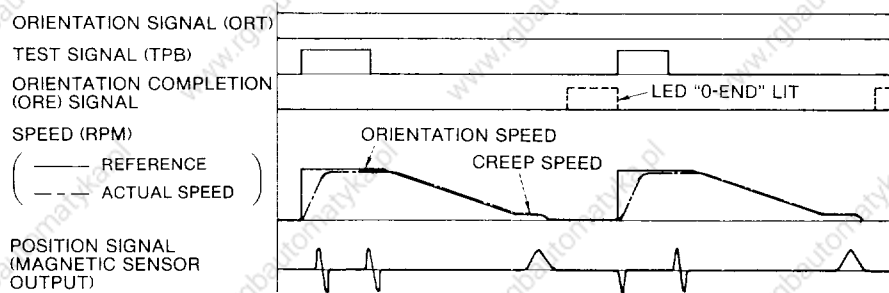

Note: Since no ORE signal is output in the test mode, a time-error state may be created with a system in which an orientation time monitoring arrangement is incorporated. With these systems, the relevant parameter or timer setting should be changed for the intended orientation test in advance.

Fig. 26.3 Time Chart for Test Mode Orientation

27 WIRING SPECIFICATIONS

27.1 INTERCONNECTIONS BETWEEN DEVICES

27.1.1 For Type FS-1378C

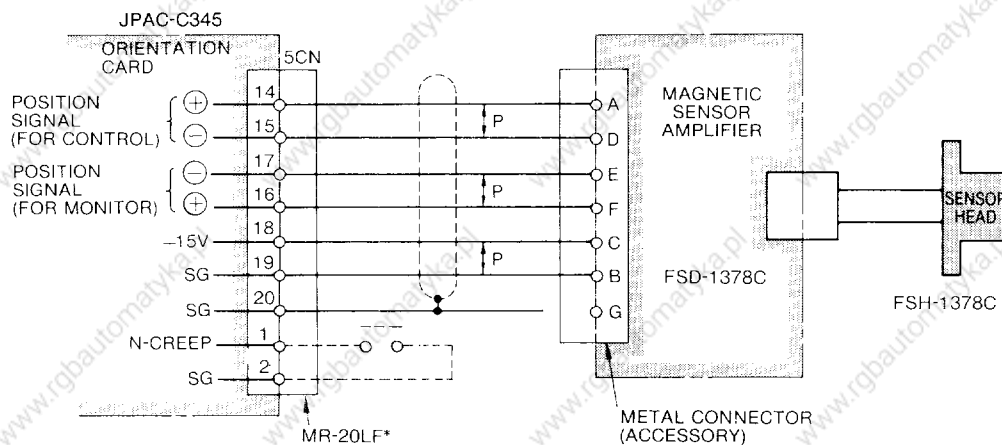

*Made by Honda Tsushin Kogyo K.K.

Note

1. Connection lead should be vinyl cable with braided copper shield (0.3mm² twisted-pair 3-P), and the distance should be within 20m.
2. shows twisted-pair leads.

27.1.2 For Type FS-200A

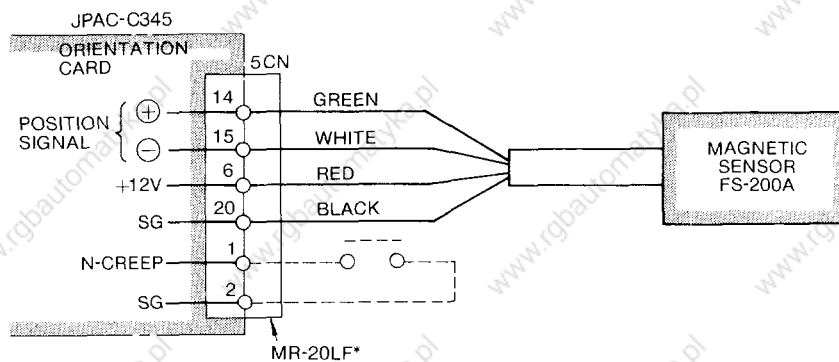

*Made by Honda Tsushin Kogyo K.K.

27.1.3 List of Connector Signal Pins

Table 27.1 List of 5CN Connector Signal Pins

Pin No.	Signal	Pin No.	Signal	Pin No.	Signal
1	N-CREEP	8	—	14	Position signal ⊖
2	SG	9	—	15	Position signal ⊖
3	—	10	—	16	Range signal ⊕
4	—	11	—	17	Range signal ⊖
5	—	12	—	18	+15V
6	+12V	13	Blind pin (Blank)	19	SG
7	SG			20	SG

27.2 DESCRIPTION OF CONTROL SIGNALS

The input/output signals used for the orientation system must be in accordance with the input signals (Fig. 5.1) and output signals (Fig. 5.3) of the VS-626MT III controller.

27.2 DESCRIPTION OF CONTROL SIGNALS (Cont'd)

Table 27.2 Description of Input/Output Signals

Signal Name	Connector No.	Pin No.	On Level	Description
Input Signal	1CN	16	L (CLOSE)	<ul style="list-style-type: none"> • Command signal for use with the electric orientation system. • When [ORT] is input, the spindle immediately decelerates and comes to a stop at the specified position. • When the operation, such as tool changing, for which spindle orientation is required is completed, clear the run signal and [ORT]. • When the system is to be energized with the power supply switch, [ORT] must be opened in advance. • If the spindle is stopped in the EMERGENCY mode during the orientation process, clear [ORT] once and then restart.
		18	L (CLOSE)	<ul style="list-style-type: none"> • This signal is for selectively engaging gears between the spindle and the spindle drive motor to obtain proper spindle speeds to shorten the time spent in the orientation process. • For the speed ratios and the gears, refer to Table 27.3. • To engage the H gear, open both [MG] and [LG]. • If [MG] and [LG] are input simultaneously, the orientation time and accuracy are adversely influenced. Never input them together.
		17		
Output Signal	1CN	39		<ul style="list-style-type: none"> • [ORE] is output (contact CLOSE) when the spindle has been stopped at the specified position within $\pm 0.2^\circ$ after receiving [ORT]. • Perform work such as tool replacement after [ORE] is output. • While [ORE] is being output, the spindle displacement is compensated exerting a reaction torque against an external torque. However, if the spindle has been obviously displaced by a strong external torque, stop operation, and clear [ORT], [FOR] and [REV]. • Connect an external sequence circuit for outputting an alarm signal when [ORE] is not output within a preset time after receiving [ORT].
Spindle Rotating [IP]		38		<ul style="list-style-type: none"> • [IP] outputs 1 pulse per spindle rotation, regardless of the [ORT].

Note: When the FS-1378C magnetic sensor is used, a monitoring position signal can be used to open **[ORE]** if the spindle is displaced after the end of an orientation process. When the FS-200A is used, **[ORE]** cannot be opened once the spindle has been oriented, unless **[ORT]** is opened, because FS-200A has no monitoring position signal.

Table 27.3 Gear Select and Gear Ratio

Gear Stage	Gear	Gear Ratio (= $\frac{\text{Spindle Speed}}{\text{Motor Speed}}$)	Gear Select	
			M Gear	L Gear
1	—	1.5 0.6 —————	×	×
	—	0.8 0.15 —————	○	×
	—	0.6 0.05 —————	×	○
2	HIGH	1.5 0.6 —————	×	×
	LOW	0.8 0.6 —————	○	×
	HIGH	1.5 0.6 —————	×	×
	LOW	0.6 0.05 —————	×	○
	HIGH	0.6 0.15 —————	○	×
	LOW	0.2 0.05 —————	×	○
3	HIGH	1.5 0.6 —————	×	×
	MEDIUM	0.8 0.15 —————	○	×
	LOW	0.6 0.05 —————	×	○

Note: For gear ratio other than value in the table above, contact Yaskawa representative.

○ ... ON, contact closed
 × ... OFF, contact open

28. DIMENSIONS AND INSTALLATION

28.1 DIMENSIONS in mm (in inches)

28.1.1 Orientation Card (Type JPAC-C345)

Dimensions in mm (in inches)

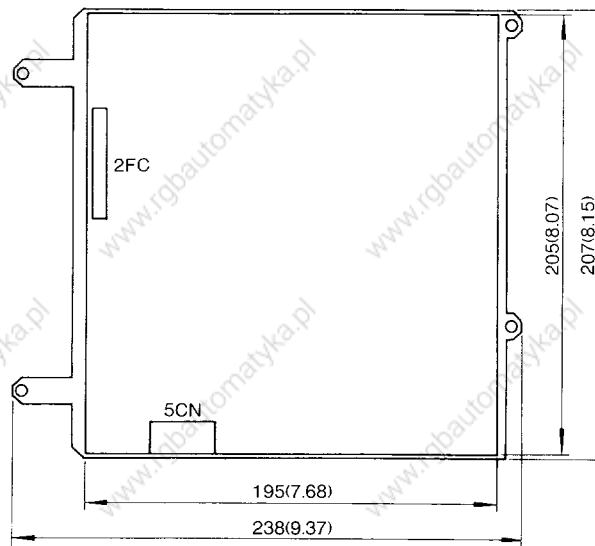

Note: When orientation card is ordered, it is mounted in VS-626MT III controller before shipment.

28. 1. 2 Magneto

(1) MG-1378BS

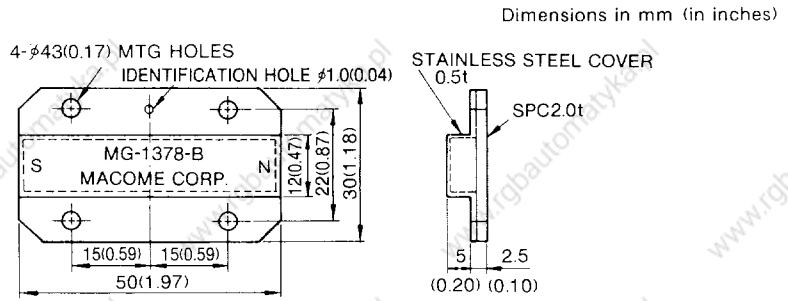

(2) MG-1444S

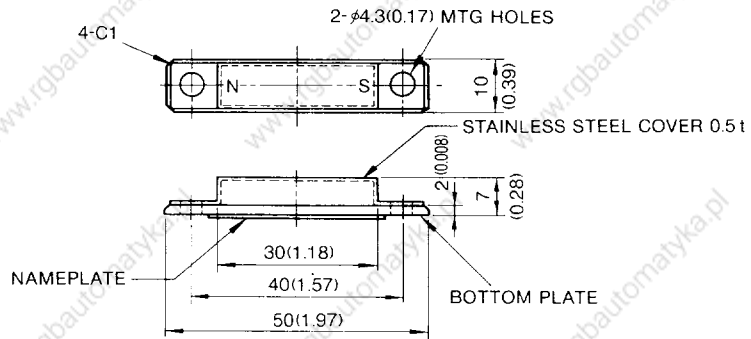

28. 1. 3 Magnetic Sensor

(1) Type FS-1378C

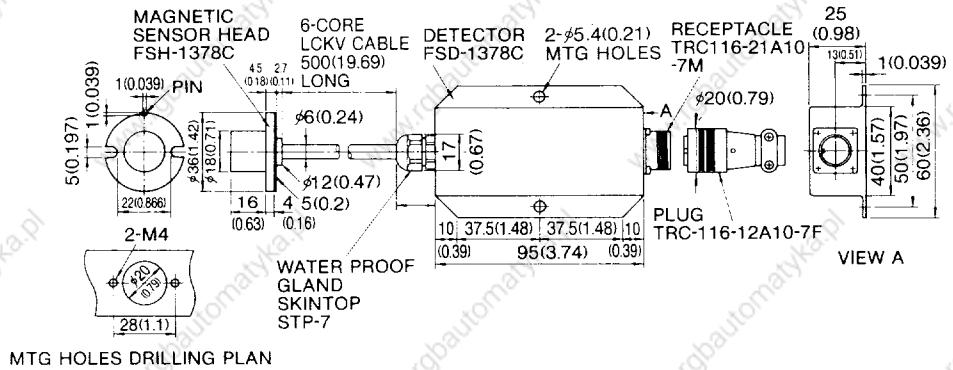

(2) Type FS-200A

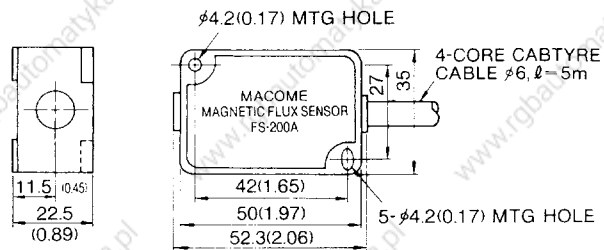

28.2 INSTALLING MAGNETO AND MAGNETIC SENSOR

The magneto is installed on the spindle, and the magnetic sensor is installed on a stationary part. Their relative position must be such that when the spindle is in the intended stop position, the magneto and the magnetic sensor are aligned center-to-center.

Fig. 28.1 shows the installing method, and Table 28.1 gives the required mounting accuracy.

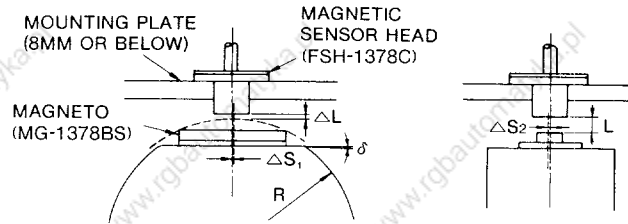

(a) MG-1378BS/FSH-1378C

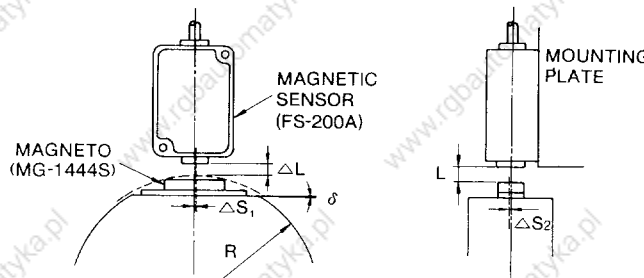

(b) MG-1444S/FS-200A

Fig. 28.1 Installing Magneto and Magnetic Sensor

Table 28.1 Mounting Accuracy

Code	Dimensions	MG-1378BS/FSH-1378C	MG-1444S/FS-200A
R	Radius of spindle member*	60 to 70 mm (2.36 to 2.76 inches)	60 to 70 mm (2.36 to 2.76 inches)
L	Gap (center of magneto to magnetic sensor†)	6 mm (0.24 inches) [6 to 8 mm (0.24 to 0.31 inches)]	5 mm (0.197 inches) [3 to 7 mm (0.12 to 0.28 inches)]
ΔL	Gap (end of magneto to magnetic sensor†)	1 to 2 mm (0.04 to 0.08 inches)	1 to 2 mm (0.04 to 0.08 inches)
ΔS1, ΔS2	Center position error of magneto and magnetic sensor‡	0.5 mm max (0.02 inches)	0.5 mm max (0.02 inches)
δ	Angular displacement error from datum plane‡	0.2° max	0.2° max

*In determining the diameter of the spindle member for installing the magneto take the permissible maximum centrifugal force of the magneto into consideration.

†The L value is a recommended value. Adjust the gap so as to satisfy the ΔL requirement.

‡In aligning magneto to the mechanical center line of the system such as the spindle nose key of a machining center, observe the specified mounting accuracy standards for the center position and angular position of the magneto.

28.3 PRECAUTIONS IN MOUNTING

- (1) Although the sensor head is designed to be resistant to oil and water, seal the bushes with silicone adhesive or the like where the sensor is subject to frequent splashing from oil or water.

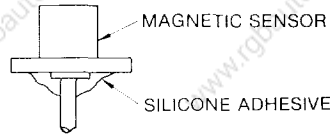

- (2) In designing the mounting arrangement for the sensor amplifier and connecting cables, avoid exposing them to water and oil splashes.
 - (3) Avoid bringing units generating magnetic fields such as solenoids and magnets near the magneto and the magnetic sensor.
 - (4) In installing the magnetic sensor head and the magneto, take care not to mechanically damage them.
 - (5) Take care to prevent iron powder or the like from depositing on the magneto.
 - (6) Install the magneto on the spindle, in order to avoid stopping position deviations due to backlash.
 - (7) Make the cable connecting the magnetic sensor amplifier and the orientation card not more than 20 meters in length.
 - (8) In installing the magneto and the magnetic sensor, pay attention to their polarity. If they are mounted with the wrong polarity, operation will be malfunctioned.
- (a) For MG-1378BS/FS-1378C

Install the magneto so that the identification hole is to the left of the center line when the motor runs in forward direction. The magnetic sensor must be installed so that the head pin groove on the sensor and the identification hole on magneto are on the same side of the center line.

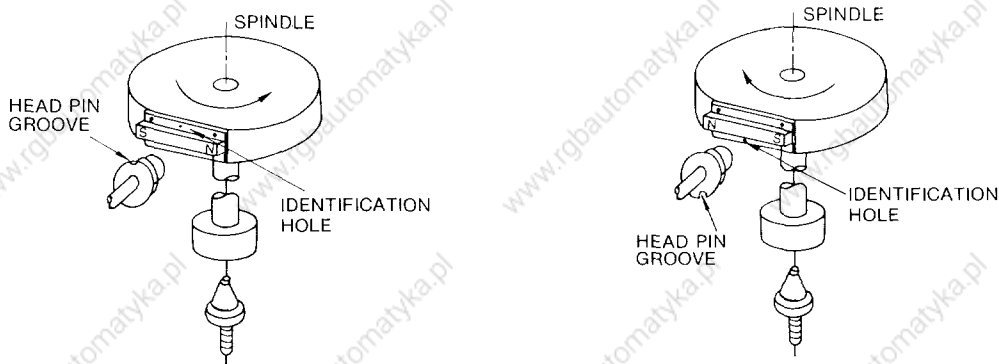

Note: The running direction of the spindle is shown in the case of the motor running in forward direction.

Fig. 28.2 Magneto and Magnetic Sensor Mounting Direction

(b) For MG-1444S/FS-200A

As shown in Fig. 28.3, where the spindle turns forward in the CCW direction, install the magneto so that its N comes on the right and S left as viewed from a stationary position, and install the magnetic sensor with the nameplate up.

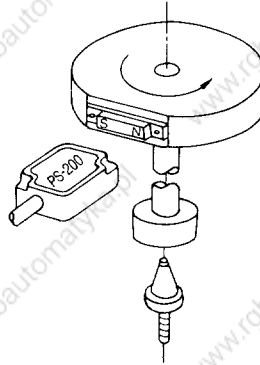

Fig. 28.3 Magneto and Magnetic Sensor Mounting Direction

29. COMPONENTS OF ORIENTATION CARD

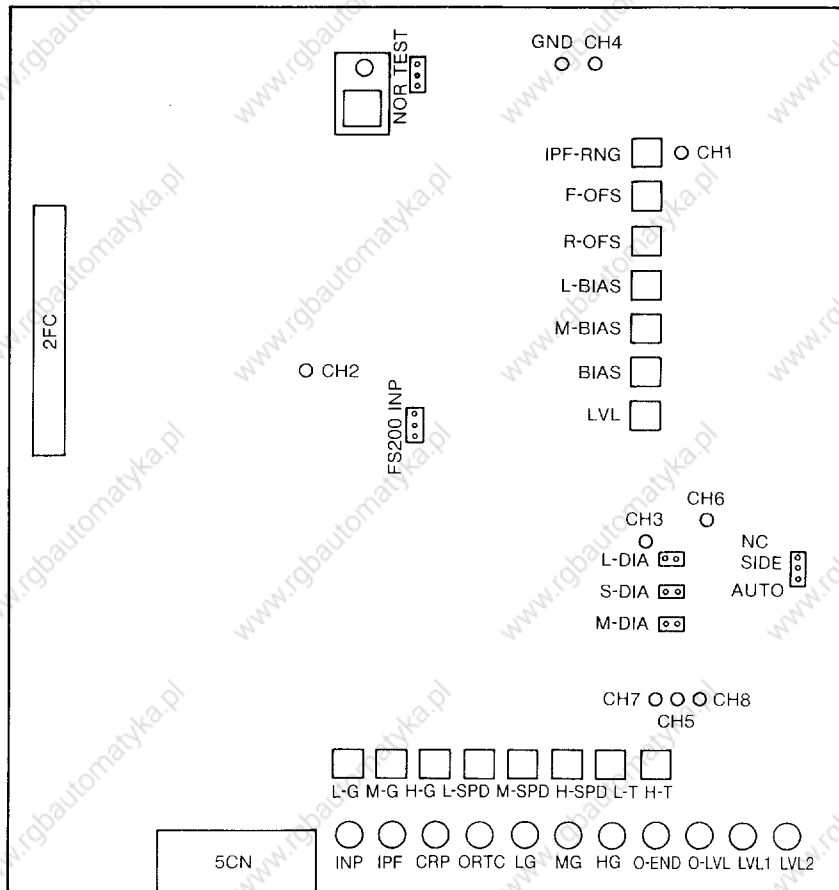

Fig. 29.1 Component Layout of Orientation Card

30. ADJUSTMENT

30.1 FUNCTION OF POTENTIOMETERS AND SHUNT CONNECTOR

30.1.1 Adjustable Potentiometers

Table 30.1 shows the potentiometers. Adjust them when adjusting the orientation performance.

Table 30.1 Adjustable Potentiometers

Code	Description	Adjusting Method and Characteristics
LVL	Adjustment of magnetic sensor output detection level	See Par. 30.3.1.
BIAS	Adjustment of stop position (H gear)	See Par. 30.3.2.
L-BIAS	Adjustment of stop position (L gear)	
M-BIAS	Adjustment of stop position (M gear)	
H-G	Adjustment of loop gain at H gear	See Par. 30.3.3.
M-G	Adjustment of loop gain at M gear	
L-G	Adjustment of loop gain at L gear	
H-T	Adjustment of deceleration time from orientation speed to creep speed at H-gear	See Par. 30.3.4.
L-T	Adjustment of deceleration time from orientation speed to creep speed at L gear	See Par. 30.3.5.

30.1.2 Potentiometers Adjusted before Shipment

Table 30.2 shows the potentiometers which are adjusted before shipment. Do not tamper with these potentiometers as their adjustment require special instruments.

Table 30.2 Potentiometers Adjusted Before Shipment

Code	Description	Standard Setting Value	Condition
F-OFS	Forward run offset adjustment	Orientation card CH1 voltage $\cong 0$ V	Magnetic sensor output = 0 V BIAS = 0 V
R-OFS	Reverse run offset adjustment		
IPF-RNG	Adjustment of orientation completion range after orientation completion		

30.1.3 Selection of Connector Setting

Table 30.3 shows the selectable connectors. Set them to the setting positions which are selected to suit the specifications.

Table 30.3 Selectable Shunt Connector

Function	Description
Run-Test Selection	TEST: At testing NORM: At running
Selection of Forward-reverse Detection	AUTO: Switching by the direction of the spindle rotation. NC SIDE: Switching by a command from the NC.
Selection of Magneto Mounting Diameter	L-DIA: ϕ 145 to ϕ 220 mm (5.71 to 8.66 inches) M-DIA: ϕ 95 to ϕ 145 mm (3.74 to 5.71 inches) S-DIA: ϕ 60 to ϕ 95 mm (2.36 to 3.74 inches)
Magnetic Sensor Selection	INP: When FS-1378C is used FS200: When FS-200A is used

30.2 ADJUSTING PROCEDURES

Adjust the system in accordance with the flow chart below.

Adjusting Procedures	Remarks				
<pre> graph TD Start([Initial setting]) --> RunSpindle[Run the spindle forward at approx. 100rpm by an NC command and run forward at 50 to 70rpm after speed coincides.] RunSpindle --> AdjustLVL[Adjust LVL potentiometer. (See Par. 30.3.1.)] AdjustLVL --> MagDir{Magneto mounting direction good?} MagDir -- NO --> CorMag[Correct the magneto mounting direction. [See Par. 28.3]] CorMag --> MagDir MagDir -- YES --> SenDir{Magnetic sensor mounting direction good?} SenDir -- NO --> CorSen[Correct the magnetic sensor mounting direction. [See Par. 28.3]] CorSen --> SenDir SenDir -- YES --> SelHG[Select H gear.] SelHG --> SetConn[Set the selectable connector to TEST and send an orientation command from NC.] SetConn --> PerfOp[Perfrom orientation operation with "TEST" bottun.] PerfOp --> CRP{Lighting interval of LED "CRP" short?} CRP -- YES --> AdjHT[Adjust H-T potentiometer.] AdjHT --> PerfOp CRP -- NO --> AdjHG[Adjust gain with H-G potentiometer. [See Par. 30.3.3.]] AdjHG --> Unstable{Spindle unstable when stopping at specified angular position?} Unstable -- YES --> AdjHG Unstable -- NO --> End((A)) </pre>	<ul style="list-style-type: none"> Initial Setting <table border="1" data-bbox="797 443 1458 674"> <tr> <td>Potentiometers</td> <td> <ul style="list-style-type: none"> “BIAS”, “M-BIAS”, “L-BIAS”: 5th graduation “LVL”, “HG”, “M-G”, “L-G”, “H-T”, “L-T”: 0 graduation </td> </tr> <tr> <td>Shunt Connector (Standard)</td> <td> <ul style="list-style-type: none"> TEST-NOR NCSIDE-AUTO* L-DIA-M-DIA* -S-DIA INP -ES200* </td> </tr> </table> <p>□ : Standard setting position *Select to suit the machine specifications.</p> <ul style="list-style-type: none"> LVL Adjustment Check that “O-LVL” is not lit. Check of Magneto Mounting Direction Check for the lighting order of LEDs “LVL-1” and “LVL-2” <ul style="list-style-type: none"> Check of Magnetic Sensor Mounting Direction Check for the lighting state of LED “INP”. <ul style="list-style-type: none"> Check of H-gear Selection Check that LED “HG” is lit. H-T Adjustment See H-T Adjustment on Par. 30.3.4. H-G Adjustment See H-G Adjustment on Par. 30.3.3 	Potentiometers	<ul style="list-style-type: none"> “BIAS”, “M-BIAS”, “L-BIAS”: 5th graduation “LVL”, “HG”, “M-G”, “L-G”, “H-T”, “L-T”: 0 graduation 	Shunt Connector (Standard)	<ul style="list-style-type: none"> TEST-NOR NCSIDE-AUTO* L-DIA-M-DIA* -S-DIA INP -ES200*
Potentiometers	<ul style="list-style-type: none"> “BIAS”, “M-BIAS”, “L-BIAS”: 5th graduation “LVL”, “HG”, “M-G”, “L-G”, “H-T”, “L-T”: 0 graduation 				
Shunt Connector (Standard)	<ul style="list-style-type: none"> TEST-NOR NCSIDE-AUTO* L-DIA-M-DIA* -S-DIA INP -ES200* 				

Adjusting Procedures	Remarks
<pre> graph TD A((A)) --> D1{Stop position correct?} D1 -- NO --> B1[Adjust BIAS potentiometer.] B1 --> D1 D1 -- YES --> P1[Return the shunt connector to NOR and check for orientation operation by an NC command.] P1 --> P2[Select M-gear.] P2 --> P3[Set the shunt connector to TEST and send an orientation command from NC.] P3 --> P4[Perform orientation operation using "TEST" button.] P4 --> D2{Lighting interval of LED "CRP" short?} D2 -- NO --> P5[Adjust gain with M-G potentiometer.] D2 -- YES --> B2[Adjust M-SPD potentiometer.] B2 --> D2 P5 --> D3{Spindle unstable when stopping at specified angular position?} D3 -- YES --> P5 D3 -- NO --> D4{Stop position correct?} D4 -- NO --> B3[Adjust M-BIAS potentiometer.] B3 --> D4 D4 -- YES --> B((B)) </pre>	<ul style="list-style-type: none"> • BIAS Adjustment See BIAS Adjustment on Par. 30.3.2. <div style="border: 1px solid black; padding: 5px; margin: 10px 0;"> <p style="text-align: center;">NOTE</p> <p>When there is no M-gear selection in machine specifications, adjusting procedures for M-gear selection should be omitted.</p> </div> <ul style="list-style-type: none"> • Check of M-gear Selection Check that LED "M-G" is lit. • M-SPD Adjustment See M-SPD Adjustment on Par. 30.3.6. • M-G Adjustment See H-G Adjustment on Par. 30.3.3. • M-BIAS Adjustment See M-BIAS Adjustment on Par. 30.3.2.

30.2 ADJUSTING PROCEDURES (Cont'd)

Adjusting Procedures	Remarks
<pre> graph TD B((B)) --> Step1[Return the shunt connector to NOR and check for orientation operation by an NC command.] Step1 --> Step2[Select L-gear.] Step2 --> Step3[Set the shunt connector to TEST and send an orientation command from NC.] Step3 --> Step4[Perform orientation operation using "TEST" button.] Step4 --> Dec1{Lighting time of LED "CRP" short?} Dec1 -- YES --> Step5[Adjust L-T potentiometer.] Dec1 -- NO --> Step6[Adjust gain with L-G potentiometer.] Step5 --> Step6 Step6 --> Dec2{Spindle unstable when stopping at specified angular position?} Dec2 -- YES --> Step6 Dec2 -- NO --> Dec3{Stop position correct?} Dec3 -- YES --> Step7[Adjust L-BIAS potentiometer.] Dec3 -- NO --> Step8[Return the shunt connector to NOR and check for orientation operation by an NC command.] Step7 --> Step8 Step8 --> End([END]) End --> Step9[Check the reverse side] </pre>	<p style="text-align: center;">NOTE</p> <p>When there is no L-gear selection in machine specifications, adjusting procedures for L-gear selection should be omitted.</p> <ul style="list-style-type: none"> • Check of L-gear Selection Check that LED "L-G" is lit. • L-T Adjustment See L-T Adjustment on Par. 30.3.5. • L-G Adjustment See L-G Adjustment on Par. 30.3.3. • L-BIAS Adjustment See L-BIAS Adjustment on Par. 30.3.2.

30.3 ADJUSTMENT OF POTENTIOMETERS

Orientation speed [n-37] (5V/300 r/min spindle speed)
 Creep speed [n-38]

Adjust at test mode.

30.3.1 LVL Adjustment

Adjustment Objective: Adjusting magnetic sensor output detection level

Adjustment Procedure: Set the LVL potentiometer to the 0 graduation. With the spindle running at orientation speed, turn the LVL potentiometer clockwise and set it where both LVL 1 and LVL 2 LEDs start to light distinctly.

If LVL potentiometer is turned further clockwise, it will cause overadjustment and "O-LVL" will light. If the LVL 1 and LVL 2 LEDs do not light in this sequence, reverse the mounting direction of the magneto.

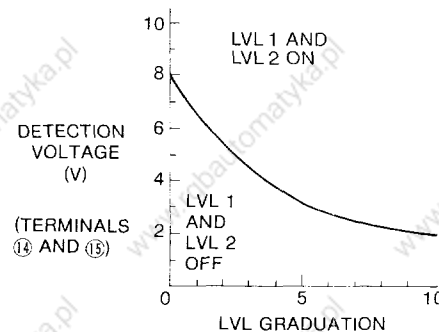

Fig. 30.1 LVL Characteristics

30.3.2 BIAS Adjustment

Adjustment Objective: Stop position fine adjustment

Adjustment Procedure: See Fig. 30.2. M-BIAS should be adjusted after setting BIAS.

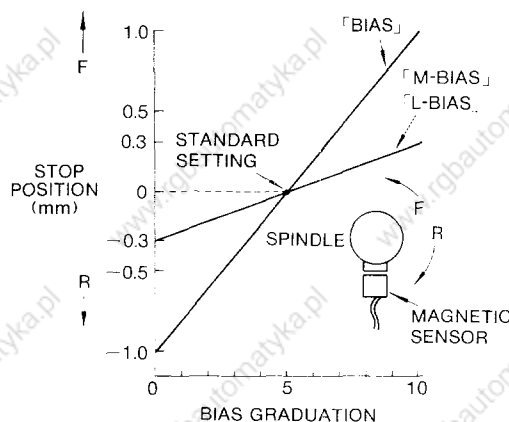

Fig. 30.2 BIAS Characteristics

30.3.3 H-G, M-G, L-G Adjustment

Adjustment Objective: Adjustment of loop gain for orientation control

Adjustment Procedure: If "O-END" does not output near stop position, raise the gain by turning the potentiometer clockwise. If spindle is hunting when "O-END" outputs, decrease the gain by turning the potentiometer count clockwise.

30.3.4 H-T Adjustment

Adjustment Objective: Adjustment of orientation time with VS-626MTⅢ gear set to H or M.

Adjustment Procedure: Set the H-T potentiometer to 0 graduation. Push the button for approximately 3 seconds in the test mode, and then release it, While turning the H-T potentiometer clockwise, repeat the orientation operation until the CRP LED lights distinctly and the lighting time becomes shortest. (Fig. 30.3). The relationship between H-T graduation and deceleration time is shown in Fig.30.4.

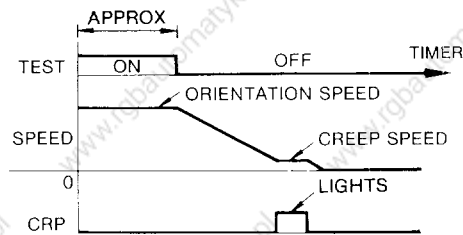

Fig. 30.3 Orientation Operation on Test Mode and lighting of CRP

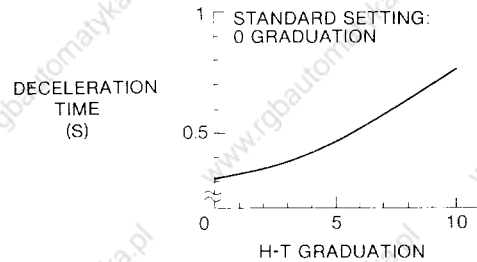

Fig. 30.4 H-T Adjusting Characteristics

30.3.5 L-T Adjustment

Adjustment Objective: Adjustment of orientation time when VS-626MTⅢ is set to L gear.

Adjustment Procedure: Set the L-T potentiometer to 0 graduation. While turning the L-T potentiometer clockwise in the test mode, push the button for approximately 3 seconds, and release, and repeat the orientation operation until the CRP LED lights distinctly, and the lighting time becomes shortest. The relationship between L-T graduation and deceleration time is shown in Fig.30.5.

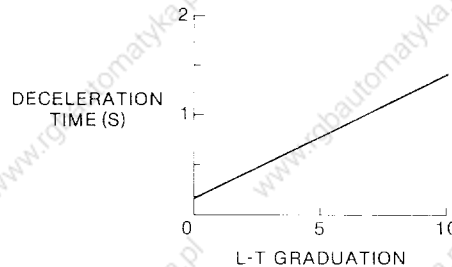

Fig. 30.5 L-T Characteristics

30.3.6 H-SPD, L-SPD Adjustment

Adjustment Objective: Orientation speed adjustment for the H or L gear selection of VS-626MTIII controller.

Adjustment Procedure: H-SPD or L-SPD potentiometer is normally set to 10 calibration.

Orientation speed [n-37]
Creep speed [n-38] } settings become
Spindle speed 5V/300 r/min when H-SPD, L-SPD
potentiometer is set to 10 graduation.

30.3.7 M-SPD Adjustment

Adjustment Objective: Orientation speed adjustment for the M gear selection of VS-626MTIII controller.

Adjustment Procedure: Adjust the "H-T" at H gear, then "M-SPD" set the M-SPD potentiometer to 10 graduation.



Select M gear in VS-626MTIII while turning the M-SPD potentiometer counter clockwise in the test mode, depress the button for approximately 3 seconds, and release, then repeat the orientation to light the CRP LED, and minimize the lighting time.

Note: When there is no M-gear selection in machine specifications, adjustment can be omitted.

31. LED DISPLAY

Table 31.1 shows the information displayed by the LEDs.

Table 31.1 LED Display

Code	Color	Information
TEST MODE	Red	Lights during test mode.
LVL 1	Green	Lights when magnetic sensor signal (CH8) exceeds the setting value (+8V). 
LVL 2	Green	Lights when magnetic sensor signal (CH8) is below the setting value (-8V). 
O-LVL	Red	Lights when magnetic sensor signal (CH8) is below the setting value (-10V). 
CRP	Green	Lights after running at creep speed until LVL 1 lights.
O-END	Green	Lights at orientation completion.
IPF	Green	Lights when the spindle enters into IN POSITION FINE (for approx $\pm 100\mu\text{m}$).
INP	Green	Lights when the spindle is in the IN POSITION.
ORTC	Green	Lights when an orientation command is given.
LG	Green	Lights when L-gear is selected.
MG	Green	Lights when M-gear is selected.
HG	Green	Lights when H-gear is selected.

Note: $\pm 100\mu\text{m}$ is measured on 120mm dia circumference.

32. CHECK TERMINALS AND THEIR SIGNALS

Table 32.1 Orientation Card Check Terminals

Check Terminal No.	Content	Signal Level
CH 1	Spindle speed reference	5V/300r/min
CH 2	Speed coincidence signal	H: +5V L: 0V
CH 3	Position deviation	0.15V/0.1mm (on 120mm diameter circumference)
CH 4	Position gain switching	H: +5V L: 0V
CH 5	Spindle speed reference (position control)	Peak: $\pm 5V$
CH 6	Spindle speed reference (Switching from orientation speed to creep speed)	10V/300r/min
CH 7	IN POSITION FINE level	0.26V
CH 8	Sensor position signal	$\pm 8V$
G	Signal ground	0V

Note: For check terminal positions, see Fig. 29.1.

33. REPLACEMENT OF ORIENTATION BOARD

(1) Removal Procedures

1. Turn off the power supply and disconnect the leads from the orientation board.
2. Remove the four PCB mounting screws.

(2) Mounting Procedures

1. Mount the board reversing the procedures described in (1) Removal Procedures.
2. Check the setting of the potentiometers, shunt connectors, etc. and start operation.

(3) Type of Orientation Board

Type: JPAC-C345

Code No.: ETC00861X

34. TROUBLESHOOTING FOR SPINDLE ORIENTATION SYSTEM

Trouble	Probable Cause	Check Method	Corrective Action
Spindle does not stop.	• Orientation command not received	• Verify the orientation command using the setting panel.	• Correct the orientation command.
	• Improper adjustment of magnetic sensor detection signal level	• Run the spindle at 100 r/min, check that LEDs "LVL1" and "LVL2" light.	• Adjust LVL potentiometer.
	• Improper adjustment of orientation card offset	• Contact Yaskawa representative.	• Adjust FOFS and ROFS potentiometers.
	• Defective orientation card		• Replace the orientation card.
Deviation from prescribed Stop Position	• Mounting direction of magnetic sensor and magneto reversed.	• Run the spindle at 100 r/min, check that LEDs "LVL1" and "LVL2" light in this order.	• Correct mounting direction of magnetic sensor and magneto.
	• Improper adjustment of position compensation signal.		• Adjust BIAS potentiometer.
	• Defective orientation card	• Contact Yaskawa representative.	• Replace the orientation card.
O-END does not light.	• Position control gain too low.		• Adjust H-G, M-G and L-G potentiometers.
	• Control signals (LGR, MGR) not received.	• Check for lighting conditions of LEDs H-G, M-G and L-G on the orientation card.	• Input appropriate control signal for selected gear.
	• Wrong setting of control constants.	• Verify the control constants by the list of settings for machines.	• Correct the control constants.
	• Position control gain too high.	• Check for any vibration when reaching stop position.	• Adjust H-G, M-G and L-G potentiometers.
	• Defective orientation card.	• Contact Yaskawa representative.	• Replace the orientation card.

Encoder Type Spindle Orientation

Encoder type spindle orientation system is used to stop the machine tool spindle at a specified position by an electrical method. This system has the following features:

(1) Simple mechanism

The specified stop position function is accomplished by mounting an encoder unit on the spindle and a magnetic sensor on the stationary member.

(2) Short orientation time

The position detection signal from the encoder forms a servo loop for accurate positioning in a short period of time, even when the spindle is running at maximum speed.

(3) Reliability and service life improvement

Substantial reduction of positioning shock by using an all electric drive, leads to higher reliability and longer service life.

(4) Economical advantage

Simplified mechanism and power control sequence result in a substantial cost reduction.

35. SPECIFICATIONS

35.1 SPINDLE ORIENTATION SPECIFICATIONS

Table 35.1 Standard Specifications

Item	Functions
Positioning Mode	Absolute/incremental programming
Position Detection Mode	Spindle angle detection by A, B and C phase pulses of encoder*
Stop Position	Position corresponding to the external command or internal setting based on spindle home position† Angle resolution: 0.088° (= 360° / 4096)
Accuracy of Stop Position Repeating	± 0.2° or below
Reaction Torque	Continuous rated torque / ±0.1° displacement‡
Orientation Card	Model JPAC-C346
Encoder	Model PC-1024ZLH (Spindle-mounted type) UTMSI-10AAB (Built-in moter type)

* It removes the mechanical errors including backlash and eccentricity.

† Spindle home position can be obtained by setting the number of offset pulses from the rising of C-phase pulse of encoder during clockwise rotation.

‡ As a result of setting a gain, continuous rated torque may not be outputted. And, sudden load variation will increase displacement.

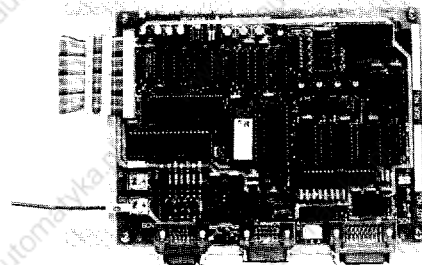

35. 2 ENCODER SPECIFICATIONS

Table 35. 2 Encoder Specification

Item	Description		
Type	PC-1024ZLH-4K-68	PC-1024ZLH-6K-68	UTMSI-10AAB
Max. Speed*	4000	6000	10000
Power Supply	+5 VDC ±5 % 350 mA.		
No. of Pulses	A, B-phase 1024 pulses/rev. C-phase 1 pulse/rev.		
Output	Each phase is of parallel output by line driver. SN75113 SN75158		
Max. Response Frequency	A, B-phase 80 kHz C-phase 78 Hz (4690 r/min)	A, B-phase 120 kHz C-phase 117 Hz (7000 r/min)	A, B-phase 188 kHz C-phase 183 Hz (11000 r/min)
Accumulated Pitch Error	Within 33 % of A-, B-phase signal frequency		Within 50 % of A-, B-phase signal frequency.
Pitch Error	Within 25 % of A-, B-phase signal frequency		
Input Shaft Inertia	Max. 1×10^{-3} kgf·cm·sec ²		58.7×10^{-3} kgf·cm·sec ²
Input Shaft Torque	Max. 1 kgf·cm		
Input Shaft Allowable Load (Thrust) (Radial)	At standstill Max. 10 kg Max. 20 kg	At running Max. 4 kg Max. 6 kg	
Structure	Dustproof, dripproof (With oil seal)		Main shaft mounting
Output Connector (Main Unit Side) (Cable Side) (Manufacturer)	MS3102A20-29P MS3106A20-29S		MLR-12 MLP-12 (Nippon Pressure Terminal Co.)
Weight	1.5 kg		0.33 kg (Encoder disk)
Applicable Temp. Range	0 to +60°C		
Humidity	10 to 95 % RH (Non-condensing)		

* Shows upper limit speed in practical use.

36. CONFIGURATION

Fig. 36.1 shows a system configuration of encoder type orientation 2-spaces. In the case of a spindle drive utilizing a built-in motor, 1-space the encoder signal of the spindle motor is used as a position detecting signal.

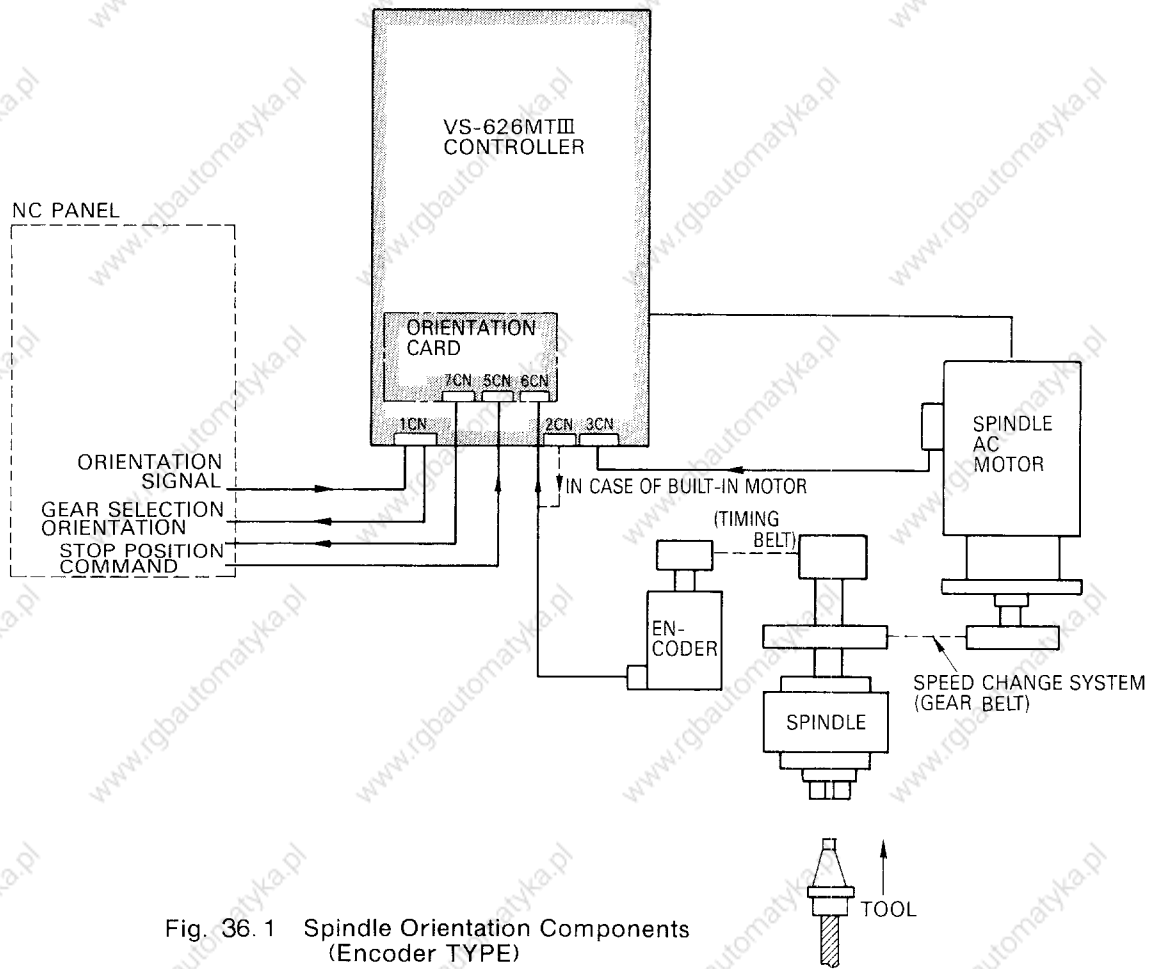

Fig. 36.1 Spindle Orientation Components (Encoder TYPE)

37. OPERATION OUTLINE

37.1 ORIENTATION CONTROL OUTLINE

Fig. 37.1 Shows encoder type Orientation Control block diagram.

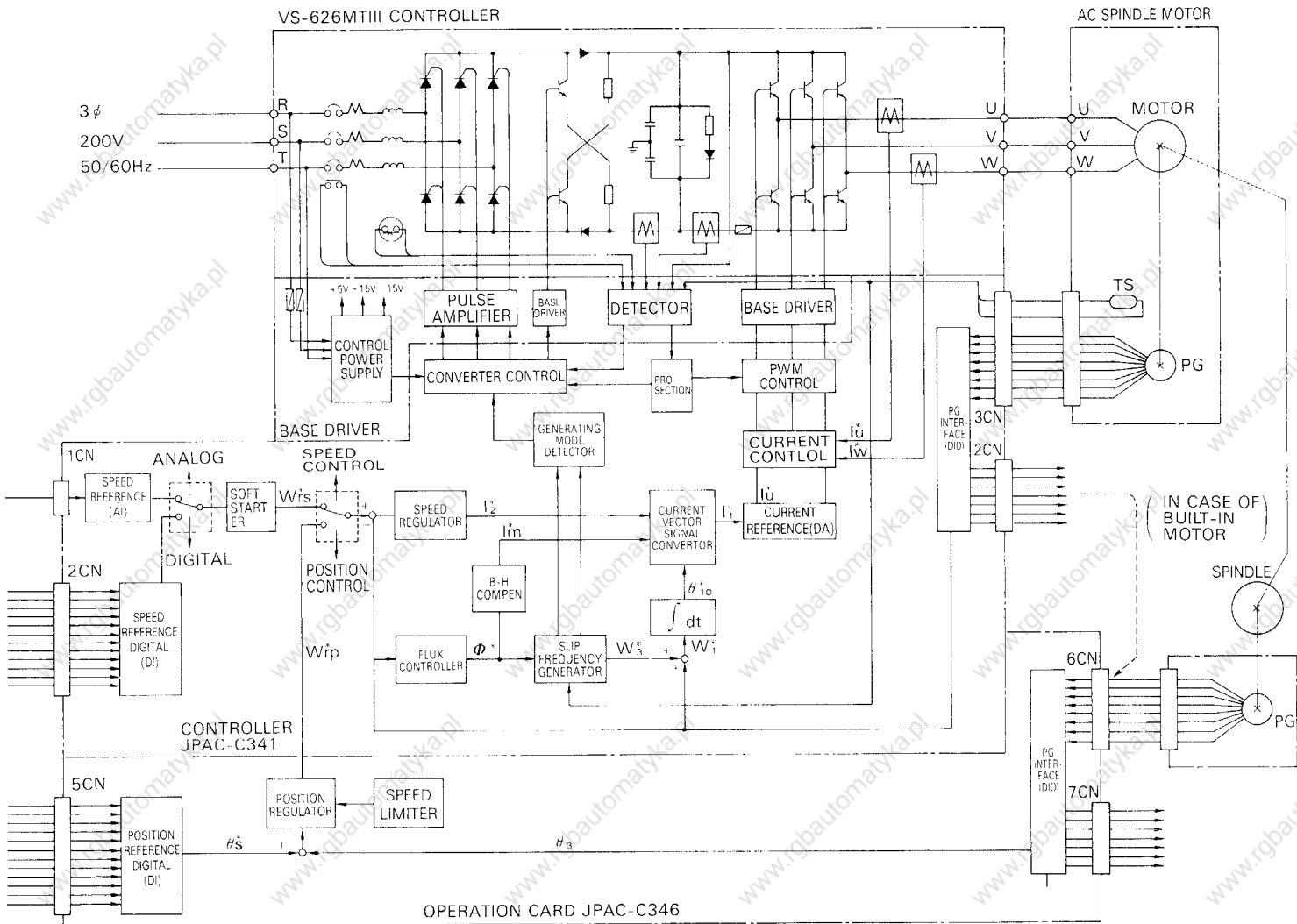
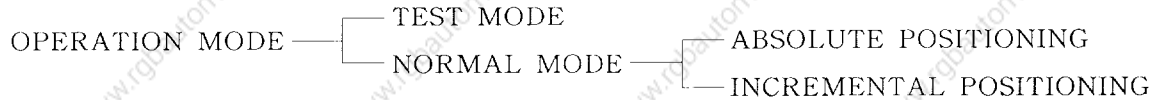

Fig. 37.1 Control Block Diagram at Orientation

37.2 ORIENTATION OPERATION

The VS-626 MTIII encoder type orientation has the following two modes. There are also two kinds of positioning operations. Select any for your application.



37.2.1 Test Mode

Test mode is designed to set the spindle home position when setting up a machine tool. 2-spaces if spindle home position is not set up, the stop position accuracy during orientation may not conform to the specification value. To prevent this trouble, checking must be made using the test mode during setup of the machine tool, or during replacement of encoder.

During test mode the Orientation Completion signal (ORE) will not be outputted, even if the motions of orientations are completed.

37.2.2 Absolute Positioning

Absolute positioning is used to position the tool at a specified stop position based on the spindle home position as the reference. Consequently, if the specified stop position is "0°", the tool will stop at the spindle home position, and if it is "90°", the tool will stop at the position 90° advanced clockwise.

When the Orientation signal is inputted during rotation (or stoppage) of the spindle, the spindle decelerates (or accelerates) promptly to the setup orientation speed.

After achieving the setup speed, the spindle stops at the position specified by servo loop after checking the C-phase signal of the encoder, and at the same time this function puts the Orientation Completion signal (ORE).

After completion of the orientation, the servo loop will continue to function. While the Orientation signal remains on, the spindle will not easily deviate from the stop position, even if an external force is applied.

Fig. 37.2 shows a time chart of absolute positioning motions.

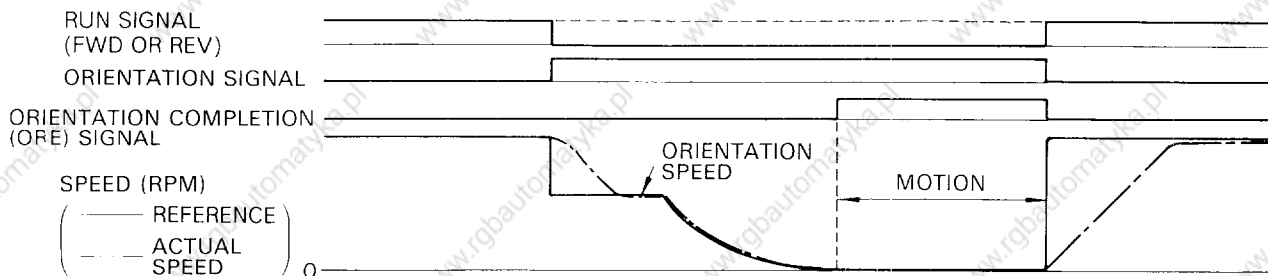

(a) Orientation when Spindle is Running

37.2.2 Absolute Positioning (Cont'd)

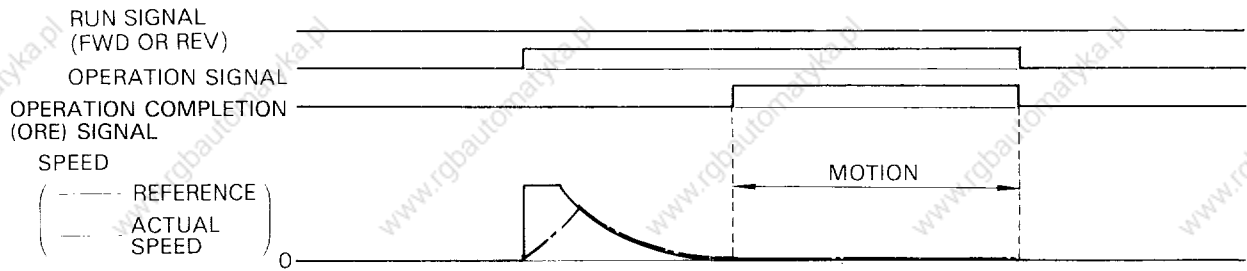

(b) Orientation when Spindle is at Standstill

Fig. 37.2 Absolute Positioning

37. 2. 3 Incremental Positioning

This function is used to move the machine table or spindle to a new stop position with a specified rotational movement amount (angle) added to the present stop position.

After completion of orientation, the incremental signal is inputted, and the machine table or spindle will stop at the new position and output an ORE signal.

While in this mode, each time the orientation signal is inputted, the spindle will advance the incremental amount.

Fig. 37.3 shows a time chart of incremental positioning motions.

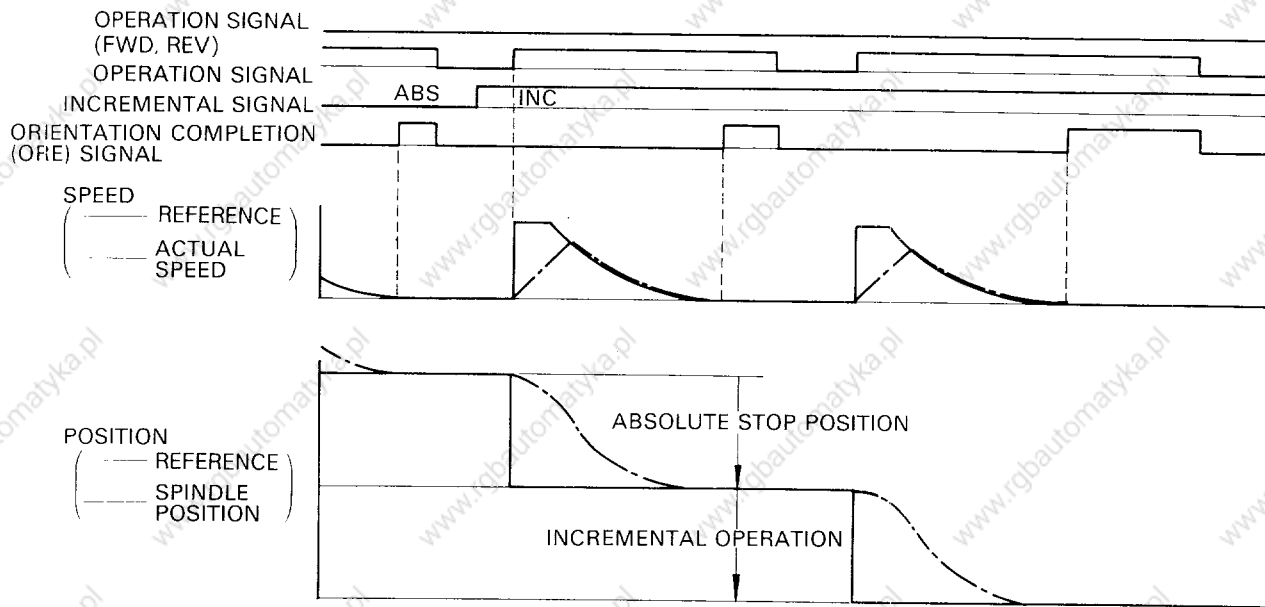

Fig. 37. 3 Incremental Positioning

Note: In performing incremental positioning, take care not to allow occurrence of positional deviation during the time when Orientation signal is in the OFF state.

When positional deviation occurs, precision of stop position may not be obtained.

38. WIRING DIAGRAM

38.1 INTERCONNECTION DIAGRAM

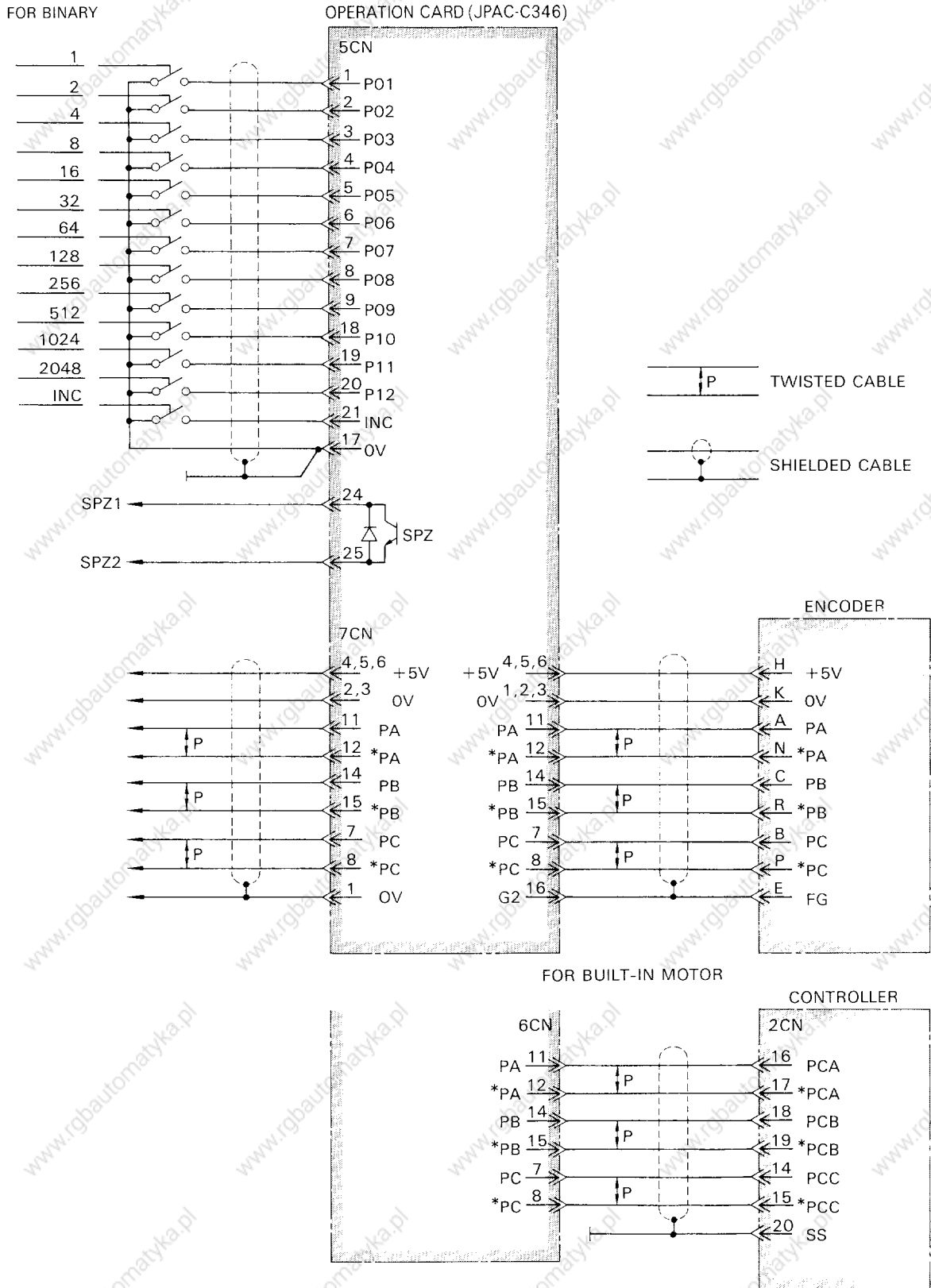

Fig. 38.1 Interconnection Diagram

38.2 CONNECTOR PIN ARRANGEMENT

17	18	19	20	21	22	23	24	25
0V	P10	P11	P12	INC			SPZ1	SPZ2
	10	11	12	13	14	15	16	
1	2	3	4	5	6	7	8	9
P01	P02	P03	P04	P05	P06	P07	P08	P09

PC-Board Connector MR-25RFAG
 Cable Connector MR-25LM (G) or MR-25LWM (G)

(a) 5CN

11	12	13	14	15	16
PA	* PA		PB	* PB	G2
	7	8	9	10	
	PC	* PC			
1	2	3	4	5	6
0V	0V	0V	+5V	+5V	+5V

PC-Board Connector MR-16RFAG
 Cable Connector MR-16LM (G) or MR-16LWM (G)

(b) 6CN

16	15	14	13	12	11
G2	* PB	PB		* PA	PA
		10	9	8	7
				* PC	PC
6	5	4	3	2	1
+5V	+5V	+5V	0V	0V	0V

PC-Board Connector MR-16RMAG
 Cable Connector MR-16LF (G) or MR-16LWF (G)

(c) 7CN

*: Reverse signals



- Note:
1. The layout of pins is for the case where the connectors on the circuit board are viewed from the fitted part.
 2. In the diagram, the symbol  represents an input signal and  an output signal.

Fig. 38.2 Connector pin Arrangement (Orientation Card)

38.2 CONNECTOR PIN ARRANGEMENT (Cont'd)

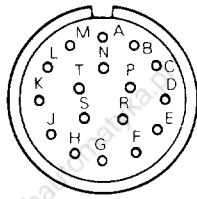

Main unit side MS3102A20-29P
 Cable side MS3108B20-29S (Angle plug)
 MS3106B20-29S (Straight plug)
 MS3057-12A (Cable clamp)

A	B	C	D	E	F	G	H	J
PA	PC	PB		FG			+5V	
K	L	M	N	P	R	S	T	
0V			* PA	* PC	* PB			

*: Reverse signals

Fig. 38.3 Connector pin Arrangement (Encoder)

38.3 PRECAUTIONS ON WIRING

- (1) Limit the length of signal cable between orientation card and encoder to less than 20 meters.
- (2) We have available the signal cable described in the specification shown in Table 38.1 You can purchase this optional item in the standard lengths according to your requirement.
- (3) During installation, keep the power cable and signal cable apart from each other to prevent interference from electrical noise.
- (4) During normal rotation of spindle, if the encoder rotates clockwise as viewed from the spindle, or if the encoder rotates counter clockwise as viewed from the spindle end, interchange A – and B – phases as shown in Fig. 38.4

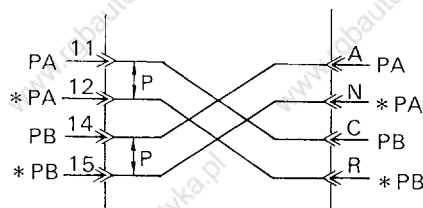

Fig. 38.4 Signal Lead Change

Table 38.1 Details of Specifications of Applicable Cables

Connection	Soldered Type	Caulking Type																																						
Yaskawa Drawing No.	DP 8409123	DE 8400093																																						
Manufacturer	Fujikura Cable Co.																																							
Approx Specifications	Double, KQVV-SW AWG 22 × 3 C AWG 26 × 6 P	KQVV-SB AWG 26 × 10 P																																						
	For Soldered Type	For Caulking Type																																						
Internal Composition and Lead Color	<table border="1"> <tr><td>A₁</td><td>Red</td></tr> <tr><td>A₂</td><td>Black</td></tr> <tr><td>A₃</td><td>Green yellow</td></tr> <tr><td>B₁</td><td>Blue White blue</td></tr> <tr><td>B₂</td><td>Yellow White yellow</td></tr> <tr><td>B₃</td><td>Green White green</td></tr> <tr><td>B₄</td><td>orange White orange</td></tr> <tr><td>B₅</td><td>Purple White purple</td></tr> <tr><td>B₆</td><td>Gray White grey</td></tr> </table>	A ₁	Red	A ₂	Black	A ₃	Green yellow	B ₁	Blue White blue	B ₂	Yellow White yellow	B ₃	Green White green	B ₄	orange White orange	B ₅	Purple White purple	B ₆	Gray White grey	<table border="1"> <tr><td>1</td><td>Blue-White</td></tr> <tr><td>2</td><td>Yellow-White</td></tr> <tr><td>3</td><td>Green-White</td></tr> <tr><td>4</td><td>Red-White</td></tr> <tr><td>5</td><td>Purple-White</td></tr> <tr><td>6</td><td>Blue-Brown</td></tr> <tr><td>7</td><td>Yellow-Brown</td></tr> <tr><td>8</td><td>Green-Brown</td></tr> <tr><td>9</td><td>Red-Brown</td></tr> <tr><td>10</td><td>Purple-Brown</td></tr> </table>	1	Blue-White	2	Yellow-White	3	Green-White	4	Red-White	5	Purple-White	6	Blue-Brown	7	Yellow-Brown	8	Green-Brown	9	Red-Brown	10	Purple-Brown
A ₁	Red																																							
A ₂	Black																																							
A ₃	Green yellow																																							
B ₁	Blue White blue																																							
B ₂	Yellow White yellow																																							
B ₃	Green White green																																							
B ₄	orange White orange																																							
B ₅	Purple White purple																																							
B ₆	Gray White grey																																							
1	Blue-White																																							
2	Yellow-White																																							
3	Green-White																																							
4	Red-White																																							
5	Purple-White																																							
6	Blue-Brown																																							
7	Yellow-Brown																																							
8	Green-Brown																																							
9	Red-Brown																																							
10	Purple-Brown																																							
Yaskawa Standard Specifications	Standard length: 5 m, 10 m, 20 m Terminal ends are not provided (with connectors)																																							

39. DESCRIPTION OF CONTROL SIGNALS

The input/output signals used for the orientation system must be in accordance with the control signals of the VS-626MTIII controller (See the descriptive information on page 17).

Table 39.1 Input Signal

	Signal Name	Connector No.	Pin No.	On Level	Description														
Controller	Orientation <input type="checkbox"/> ORT	1CN	16	L (Close)	<ul style="list-style-type: none"> • Command signal for use with the electric orientation system. • When <input type="checkbox"/> ORT is input, the spindle immediately decelerates and comes to a stop at the specified position. • When an operation, such as tool changing, for which spindle orientation is required is completed, clear the run signal and <input type="checkbox"/> ORT . • When the system is to be energized with the power supply switch, <input type="checkbox"/> ORT must be opened in advance . • If the spindle is stopped in the EMERGENCY mode during the orientation process, clear <input type="checkbox"/> ORT once and then restart. 														
	M-Gear Slection <input type="checkbox"/> MG L-Gear Selection <input type="checkbox"/> LG		18 17	L (Close) L (Close)	<ul style="list-style-type: none"> • This signal is designed to change such parameters as gear ratio and gain so that the optimum control can be performed according to the gear selection by the spindle. • Use the Gear Select signal as shown in the following cable. <table border="1"> <thead> <tr> <th>MG</th> <th>LG</th> <th>Description</th> </tr> </thead> <tbody> <tr> <td>H</td> <td>H</td> <td>H Gear Selection</td> </tr> <tr> <td>L</td> <td>H</td> <td>M Gear Selection</td> </tr> <tr> <td>H</td> <td>L</td> <td>L Gear Selection</td> </tr> <tr> <td>L</td> <td>L</td> <td>M Gear Selection</td> </tr> </tbody> </table> <ul style="list-style-type: none"> • For information regarding gear ratio and gear selection see Table 39.2 	MG	LG	Description	H	H	H Gear Selection	L	H	M Gear Selection	H	L	L Gear Selection	L	L
MG	LG	Description																	
H	H	H Gear Selection																	
L	H	M Gear Selection																	
H	L	L Gear Selection																	
L	L	M Gear Selection																	
Orientation Card	External Stop Positon Reference	5CN	1 to 9 18 to 20	L (Close)	<ul style="list-style-type: none"> • This is a Stop Position reference which is input from outside with the spindle home position assumed as 0 (zero). • For position reference, either a 12-bit binary or 3-digit BCD may be selected. <table border="1"> <tbody> <tr> <td rowspan="2">Absolute</td> <td>Binary</td> <td>Data 12 bit</td> <td>0° to 359.9° (000_H to FFF_H)</td> </tr> <tr> <td>BCD</td> <td>Code 1 bit Data 3 digit (11 bit)</td> <td>- θ to + θ (-799_D to +799_D)</td> </tr> <tr> <td rowspan="2">Incremental</td> <td>Binary</td> <td>Code 1 bit Data 11 bit</td> <td>-180° to 179.9° (-000_H to +7FF_H)</td> </tr> <tr> <td>BCD</td> <td>Code 1 bit Data 3 digit (11 bit)</td> <td>- θ to + θ (-799_D to +799_D)</td> </tr> </tbody> </table>	Absolute	Binary	Data 12 bit	0° to 359.9° (000 _H to FFF _H)	BCD	Code 1 bit Data 3 digit (11 bit)	- θ to + θ (-799 _D to +799 _D)	Incremental	Binary	Code 1 bit Data 11 bit	-180° to 179.9° (-000 _H to +7FF _H)	BCD	Code 1 bit Data 3 digit (11 bit)	- θ to + θ (-799 _D to +799 _D)
Absolute	Binary	Data 12 bit	0° to 359.9° (000 _H to FFF _H)																
	BCD	Code 1 bit Data 3 digit (11 bit)	- θ to + θ (-799 _D to +799 _D)																
Incremental	Binary	Code 1 bit Data 11 bit	-180° to 179.9° (-000 _H to +7FF _H)																
	BCD	Code 1 bit Data 3 digit (11 bit)	- θ to + θ (-799 _D to +799 _D)																



Table 39.2 Gear Select and Gear Ratio

Gear Stage	Gear	Gear Ratio (= $\frac{\text{Spindle Speed}}{\text{Motor Speed}}$)	Gear Select	
			M Gear	L Gear
1	—	1.5 / 0.6	×	×
	—	0.8 / 0.15	○	×
	—	0.6 / 0.05	×	○
2	HIGH	1.5 / 0.6	×	×
	LOW	0.8 / 0.6	○	×
	HIGH	1.5 / 0.6	×	×
	LOW	0.6 / 0.05	×	○
	HIGH	0.6 / 0.15	○	×
	LOW	0.2 / 0.05	×	○
3	HIGH	1.5 / 0.6	×	×
	MEDIUM	0.8 / 0.15	○	×
	LOW	0.6 / 0.05	×	○

Note: For gear ratio other than value in the table, contact a Yaskawa representative.

○ ... ON, contact closed
 × ... OFF, contact open

Table 39.3 Output Signal

	Signal Name	Connector No.	Pin No.	On Level	Description
Orientation Card	Orientation Completion	1CN	39  41	L (Close)	<ul style="list-style-type: none"> • [ORE] will turn on when [ORT] is inputted and the spindle arrives at the stop position. • So long as [ORE] is in the ON state, this function compensates the positional deviation by generating a counter torque against any external forces. So, such operations as tool change and work change should be performed during this period. • When positional deviation increases due to a large external force, [ORE] will turn off, causing an orientation sequence alarm.
	Spindle Position	5CN	24  25	L (Close)	<ul style="list-style-type: none"> • This function performs the same motions as [ORE], and it turns on only when orientation is completed at the spindle home position.

39. DESCRIPTION OF CONTROL SIGNALS (Cont'd)

Encoder (PG) pulse output circuit

PA *PA PB *PB PC *PC Asterisk (*) represents a reverse signal.

This circuit outputs A-phase, B-phase and C-phase (origin) signals of PG (1024 pulses/rev).

Please use them as position signals. The specifications of output signals are as follows.

(1) Signal type

Two-phase pulse (A-phase, B-phase) with 90° phase difference and origin pulse (C-phase)

(2) Output circuit and receiver circuit

As an output circuit, we have available a line drive system output circuit. Fig. 39.1 shows an example of connecting circuit.

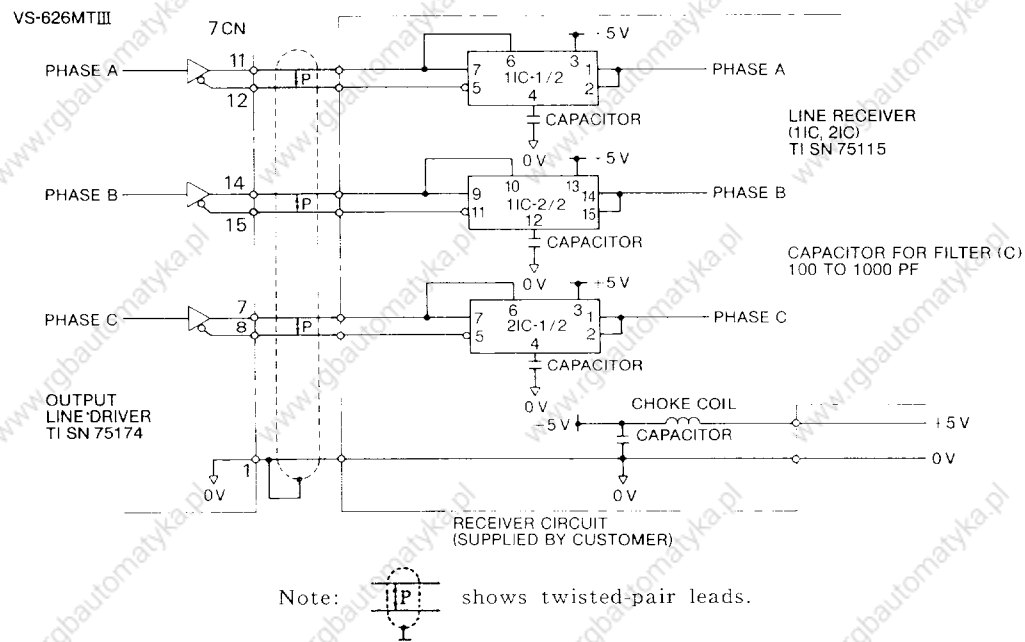

Fig. 39.1 Output and Receiver Circuits Example

(3) Output phases

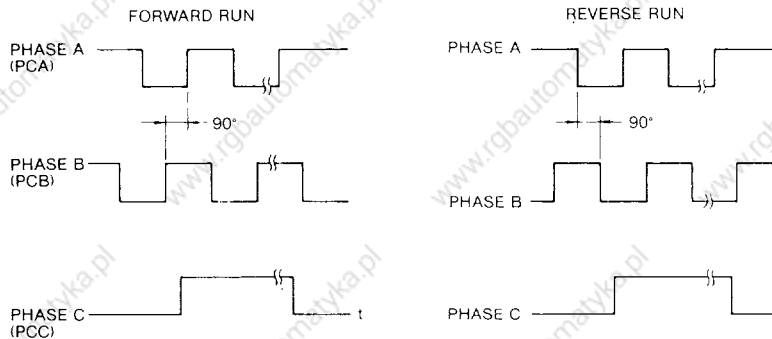
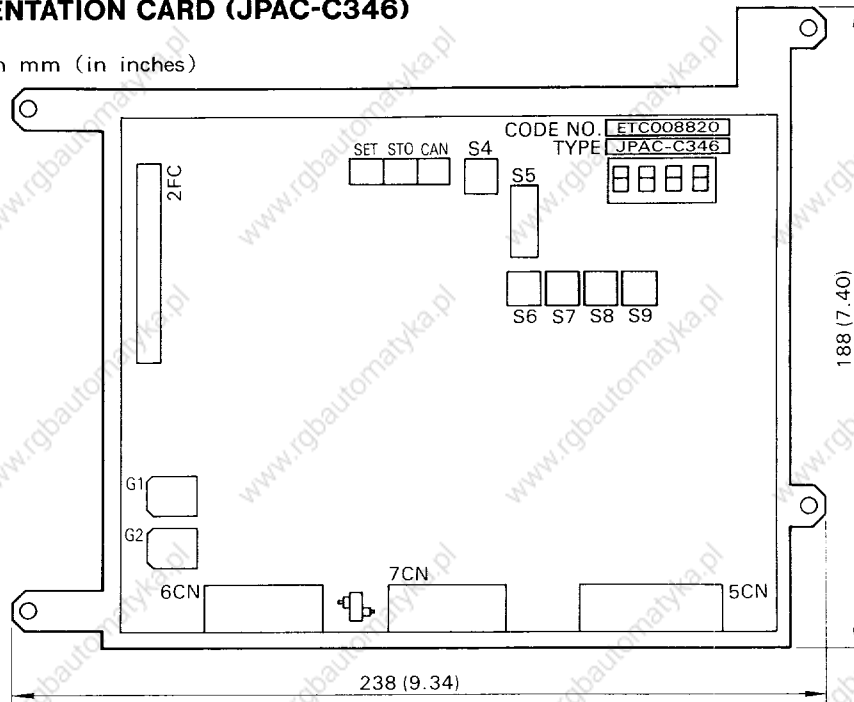

Fig. 39.2 Output Phases

40. DIMENSIONS AND INSTALLATION

40.1 ORIENTATION CARD (JPAC-C346)

Dimensions in mm (in inches)



Note: Orientation card is mounted to the proper unit at time of shipment from factory.

40.2 ENCODER (PC-1024ZLH-□K-68)

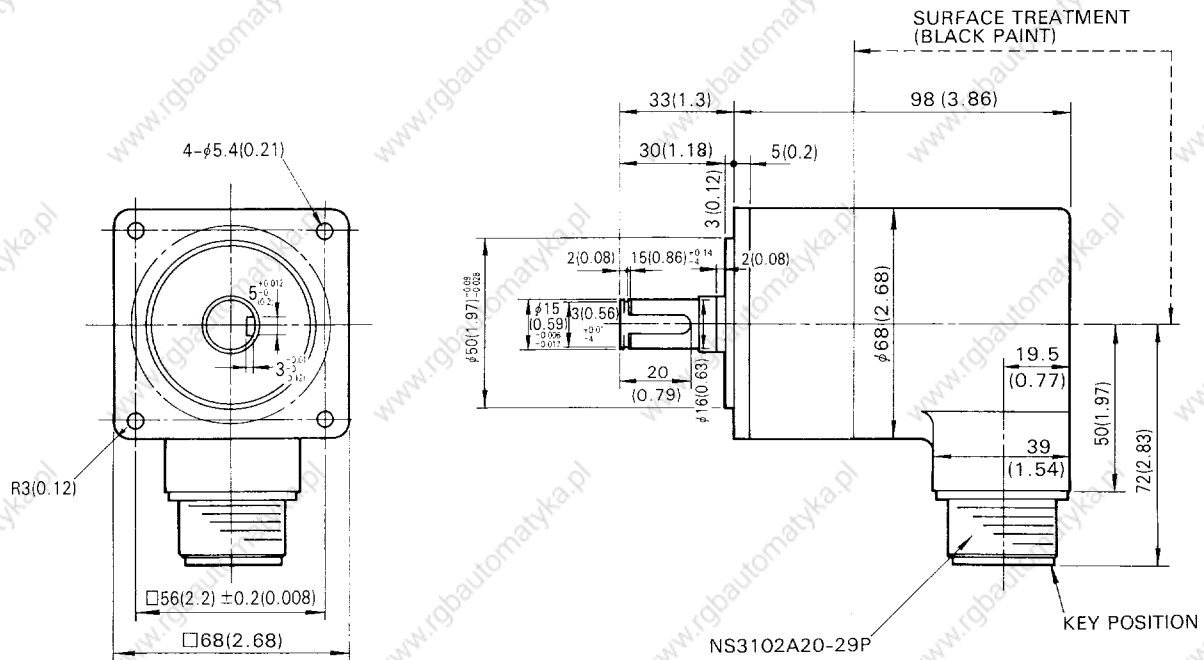

Note :

1. Install the encoder with the greatest possible care, so as not to generate backlash, because it will lead to a positional deviation.
2. Besides this type of encoder, there is one without a flange and another with a 160 mm flange.
3. Please contact us for information about built-in motor type encoder.

41. ADJUSTMENT

41.1 FUNCTIONS OF DIP SWITCHES AND SELECT CONNECTORS

DIP switches and select connectors and their contents are shown in Table 41.1.

Table 41.1 Dip Switches and Select Connectors

	Selection of orientation action mode	ON	Test mode (This is used for setting spindle origin.)
		OFF	Normal mode
	Selection for determining ABS positioning direction	ON	Fixed (Rotational direction is selected by switch 3.)
		OFF	Automatic (Rotational direction is determined when spindle speed is higher than 10 rpm, and position is determined when spindle speed is lower than 10 rpm.)
	Designation of ABS positioning direction	ON	Spindle rotation CCW
		OFF	Spindle rotation CW
	Selection of stop position commanding method.	ON	3-digit BCD(Resolution is set with control constant F_{-08})
		OFF	12-bit binary
	Selection of reference point during incremental positioning(Note)	ON	Present stop position
		OFF	Previous stop command position
Selection of control signal and constant items.	ON	Item Nos. 10 to 1F.	
	OFF	Item Nos. 0 to 1F.	
Selection of control constant protect	ON	Changing of constant allowable.	
	OFF	Changing of constant not allowable.	
	A	A	It is supplied from the NC side.
	B	B	It is supplied from orientation card.

Note : Selects the reference point where incremental motions are performed.

In case of S 5-6 OFF (90° setting)

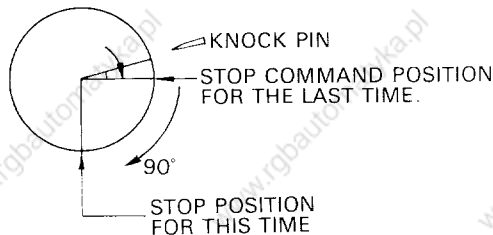

θ : Deviation angle caused by knock pin

Fig. 41.1

In case of S 5-6 ON (90° setting)

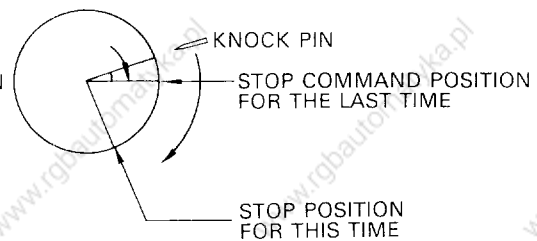

θ : Deviation angle caused by knock pin

Fig. 41.2

41. 2 SETTING OF CONTROL CONSTANTS MONITORING OF CONTROL SIGNALS

Using the DIP rotary switches, pushbutton switches, and data display (shown in Table 41.2) on the orientation card, the following operations are available.

- (1) Display of control signals
- (2) Display and setting of constants
- (3) Display of alarm contents

Table 41. 2 Setting Part and Display Part on Orientation Card

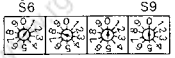
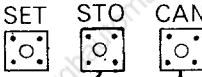
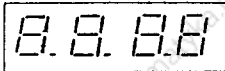
Function	Name	Form	Content
Setting Part	Item No. select switch	 (Hexadecimal 1-digit)	Select switch for control constant and control signal (This select switch combined with switch 7 of S5 allows selection in the range 0~F, 10~1F.)
	Data setting switch	 (Decimal 4-digit)	Control constant data setting switch (Programmable range: 0000 - 9999 ^(Note))
	SET		Data setting change switch
	STORE		Data memory (nonvolatile) rewrite switch
CANCEL	Test mode Starts setup motion. Normal mode Cancels the setting of control constant.		
Display Part	Data display		Display of control signal, control constant and alarm content

Note: An actual programmable range may be narrower for some data settings.

41. 2. 1 Operation of Switches and Displays

(a) After charging power source:

- Check LED _____
- Check PROM. _____
- Displays set item No. _____
(S4 is set to "0" at factory.)
- Displays control signal _____
and control constants selected.

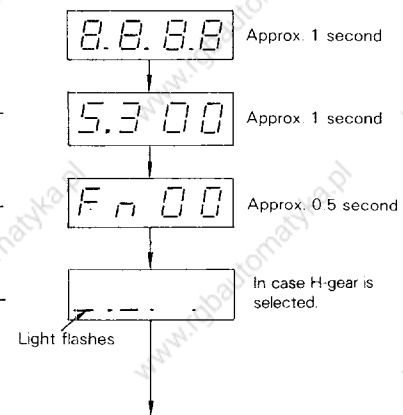

41.2.1 Operation of Switches and Displays (Cont'd)

(b) Display of control signals

- Select the control signal that is required to be monitored by operating item No. setting switch.
- Displays the item. No. that is set up. —
- Displays the data of control signal. —

(c) Setting of control constant

- Select the control constant that is required to be set up by operating the item No. setting switch.
- Displays the item No. that is selected. —
- Displays the data of control constant. —
- Set up new data by operating the data setting switches.

- Set the data that is set up. (Push the "SET" switch.)

Note: Data cannot be set during running (including orientation), except Fn-02-04.

- Cancel the set data, if it is set incorrectly. (Push the "CAN" switch.)
- If the setup data is correct, store it in the data memory.

Depress the "STO" switch for approximately 1.5 seconds, until the data light stops flashing.

- End of setting of control constant —

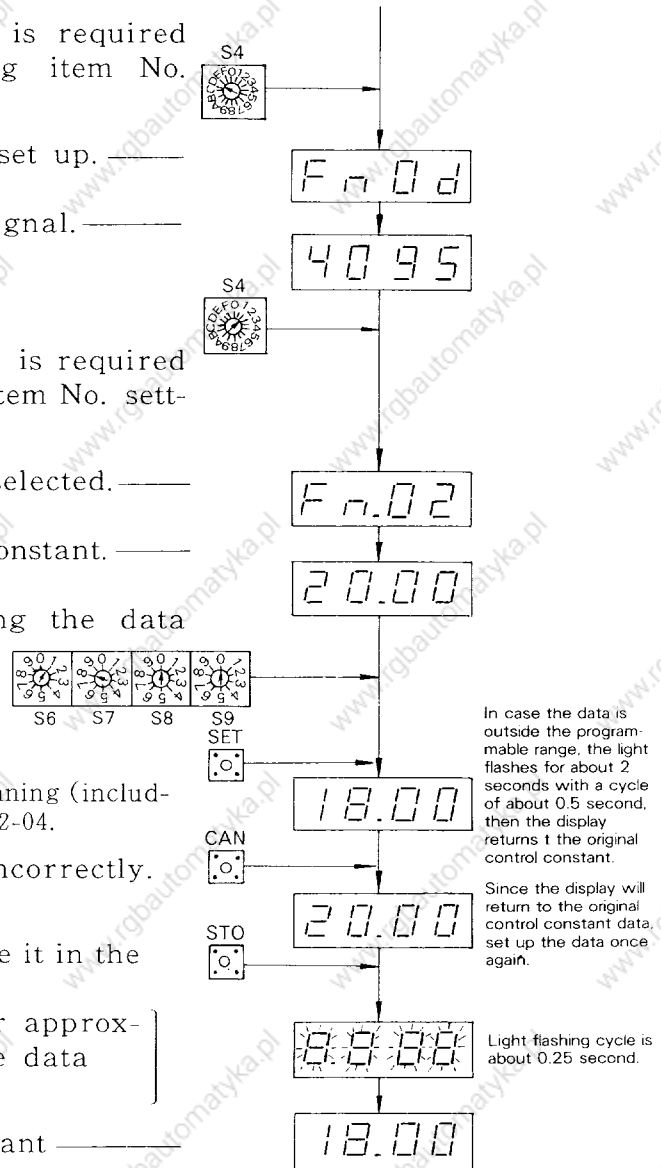

Note: Once the data is stored in the data memory, it cannot be cancelled by pushing the "CAN" switch. In this case, set up a new data, then depress the "SET" switch. If the data is set correctly, depress the "STO" switch to store the data in the data memory. Unless you depress the "STO" switch, the control constant data will not change.

(d) Alarm display

- Occurrence of an alarm causes the mode to change over to alarm display mode.
- To reset the alarm, depress the "ALM RESET" switch on the controller.

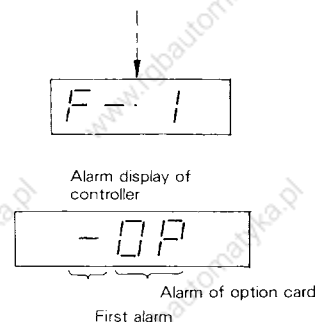

41.2.2 Control Signals and Control Constants

Table 41.3 Control Signals and Control Constants

F ₁₁ - No.	Switch Setting		Name	Control Constant			Control Signal		
	S5 ⑦	S4		Lower Limit Value	Upper Limit Value	Unit	Displayed at Power ON.	Unit	
0	OFF	0	I/O signal state				(Note)		
1		1	Spindle origin	0	4095	Pulse			
2		2	Position control, proportional gain.	H-gear	1.00	99.99			
3		3			M-gear	1.00	99.99		
4		4			L-gear	1.00	99.99		
5		5	Positioning end detection width	0	200	Pulse			
6		6	Positioning end cancellation width	0	200	Pulse			
7		7	Orientation speed	30	600	rpm			
8		8	BCD command resolution	0.5	180.0				
9		9	Stop position bias width	0	100	Pulse			
A		A							
B		B							
C		C							
D		D	Spindle position monitor				According to stop position	Pulse	
E		E	Spindle stop position command				According to stop position	Pulse	
F		F	Spindle speed monitor				0	r/min	
10		ON	0						
11			1						
12			2						
13	3								
14	4		Decel rate of orientation speed	0	100				
15	5								
16	6		Reducing rate of orientation speed	0	9999				
17	7		For internal monitor						
18	8		Spindle origin width				According to encoder	Pulse	
19	9								
1 A	A								
1 B	B								
1 C	C		For internal monitor						
1 D	D								
1 E	E								
1 F	F								

Note: Correspondence between I/O signal state and display LED is as follows:

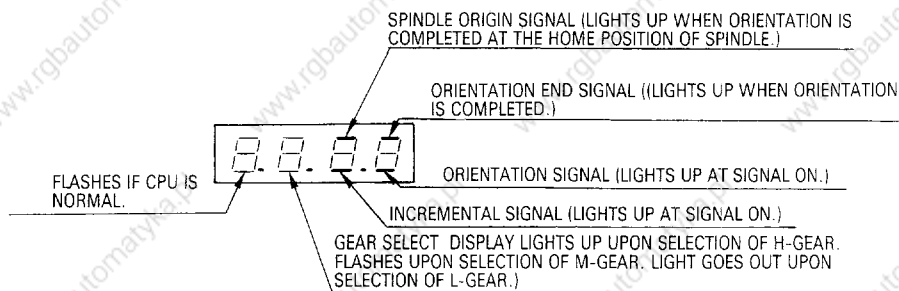

41. 2. 3 Display of Alarm

Table 41. 4 Alarm Indication

No.	Display	Setting Panel Display	Detection	Probable Cause
1	No alarm displayed	Note: -OP	CPU trouble	Defective circuitry in orientation card.
2	F-1		Internal RAM error.	
3	F-2		External RAM error.	
4	F-3		PROM error.	
5	F-4		NVRAM error.	
6	F-8	-OP	Encoder signal abnormal.	Signal cable disconnected, etc.
7	F-82		A-, B- and C-phase pulses of encoder defective.	
8	F-83		C-phase pulse width abnormal.	Wide fluctuation of C-phase edge.
9	F-84		C-phase polarity error.	PC and *PC are connected inversely.
10	dR-0	-OP	NV RAM contents data zero.	Defective circuitry in orientation card.
11	dFAL		NV RAM contents default error.	
12	bCC.E		NV RAM bcc check error.	
13	INC.E	No alarm displayed.	Incremental command error.	Timing error of incremental command.

Note: Alarm display of controller is "OP" (Option error), and alarm code is "0010"

41.3 ADJUSTING PROCEDURE

Adjust the system according to the flow chart below.

Adjusting item and procedure	Content
	<p>Initial setting (Be sure to carry out before turning on the power).</p> <ul style="list-style-type: none"> • S5...Switch 1 and 8 ON, Switch 2 ~ 7 OFF. • Select connector ... "B", if not specified. • S4 ... "F", S6 ~ 9 ... All "0" <p>Gear ratio constant ... Change the constant by the setting panel of controller (J P A C - C 341).</p> <ul style="list-style-type: none"> • C n - 2 2 ... H-gear ratio • C n - 2 3 ... M-gear ratio • C n - 2 4 ... L-gear ratio <p>0.050 1.500</p> <ul style="list-style-type: none"> • See section 11.1.8 of the System Information • When gear ratio was selected, the changed constant is effective with turning off and on the power. <p>Three-axis speed monitor check</p> <ul style="list-style-type: none"> • During normal run ... $\square \square \square \square$ (r/min) • During reverse run ... $\square \square \square \square$ (r/min) <p>Identifying input signal</p> <ul style="list-style-type: none"> • S4 ... "0" <p>Setup motions</p> <p>Note: Normal, if End LED lights up, after S4 is set at "0"</p> <p>Spindle origin setup</p>

41.3 ADJUSTING PROCEDURE (Cont'd)

Adjusting item and procedure	Content
<pre> graph TD Start((1)) --> S1[Setup end. (Orientation signal OFF).] S1 --> S2[According to equipment specifications, select DIP switch and specify constant.] S2 --> S3[Turn orientation signal on.] S3 --> D1{Does it stop smoothly?} D1 -- NO --> A1[Adjust stop position bias also. (Fn-9)] A1 --> S3 D1 -- YES --> D2{Is positional accuracy insufficient or is hunting condition present?} D2 -- YES --> A2[Adjust position control proportional gain. (Fn-2)] A2 --> S4[Select M-gear.] S4 --> S5[Turn orientation signal on.] S5 --> D3{Is positional accuracy insufficient or is hunting condition present?} D3 -- YES --> A3[Adjust position control proportional gain. (Fn-3)] A3 --> S6[Select L-gear.] S6 --> S7[Turn orientation signal on.] S7 --> D4{Is positional accuracy insufficient or is hunting condition present?} D4 -- YES --> A4[Adjust position control proportional gain. (Fn-4)] A4 --> S8[End of adjustment] D4 -- NO --> S8 </pre>	<ul style="list-style-type: none"> In case of occurrence of abnormality during setup, carry out setup operations once again, after resetting. <p><u>Selecting DIP switch</u></p> <ul style="list-style-type: none"> S1, 7...OFF, S8...ON, S2, 3, 4, 6...Conform to equipment specification. <p><u>Setting control constant</u></p> <ul style="list-style-type: none"> Fn-5~8... Conform to equipment specifications. <p><u>Adjusting stop position bias (Fn-9)</u></p> <ul style="list-style-type: none"> Adjust so that the last advancing is not slow and that there is no overshoot. <ul style="list-style-type: none"> Identify the characteristics from H-, M-, and L-gear, because the characteristics vary with load inertia. <p><u>Adjusting proportional gain (Fn-2)</u></p> <ul style="list-style-type: none"> If ORE is not outputted in the region near the stop position, increase the gain. If the spindle is unsteady even if ORE is outputted, reduce the gain. <p>* If M-Gear selection is not covered by the equipment specifications, omit the adjustment.</p> <p><u>Identifying gear selection.</u></p> <ul style="list-style-type: none"> S4... "0" <p><u>Adjusting proportional gain (Fn-3)</u></p> <ul style="list-style-type: none"> See the above description "Adjustment of Fn-2" <p>* If L-gear selection is not covered by equipment specifications, omit adjustment.</p> <p><u>Identifying selection of L-gear.</u></p> <ul style="list-style-type: none"> S4... "0" <p><u>Adjusting proportional gain (Fn-4)</u></p> <ul style="list-style-type: none"> See the above description "Adjustment of Fn-2".

41.4 SETTING EACH PART

Setting method of the main control constants is described below.

41.4.1 Spindle Origin (Fn01)

Setting of spindle origin is performed in the Test mode. Setting of the position of spindle origin is performed with the number of pulses from the rising of C-phase pulse during normal rotation of spindle to the spindle origin. Programmable range is $0 (0^\circ) \sim 4095 (359.9^\circ)$.

41.4.2 Positioning End Detection Width (Fn05) and Positioning End Cancellation Width (Fn06)

Setting of positioning end detection width and cancellation width should be performed during stoppage. Orientation end signal turns on when the difference between stop command position and stop position is less than value of Fn05, for more than 60ms. If after the orientation end signal is outputted, the difference becomes more than the end cancellation width, the orientation end signal will turn off.

Both positioning end detection width (Fn05) and cancellation width (Fn06) can be programmed in the range from $0 (0^\circ)$ to $200 (17.6^\circ)$, but any value smaller than end detection width cannot be set in the end cancellation width. When a wide end detection width is set after setting an end cancellation width, the end cancellation width will automatically become the same value as the end detection width. $F_{n06} \cong F_{n05}$

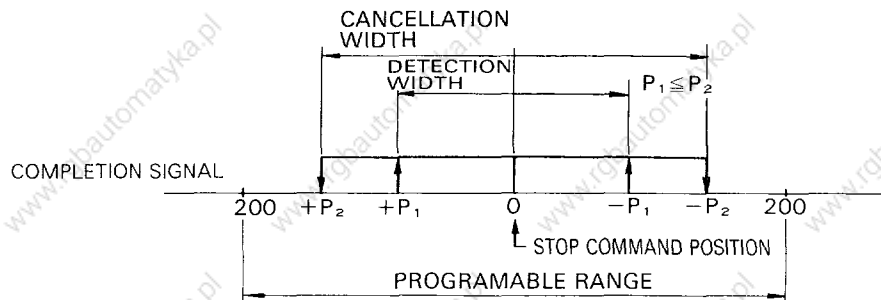

Fig. 41.3 End Signal Detecting Position

41. 4. 3 BCD Reference Resolution (Fn08)

Setting of BCD reference resolution should be performed during stoppage. BCD reference resolution can be set in the range from 0.5° to 180.0° , but the stop position reference is within 360° .

For example, when the set value is 90° , the BCD reference resolution is 90° if stop position reference is "1", 180° if stop position reference is "2", 0° if stop position reference is "4" and 90° if stop position reference is "5"

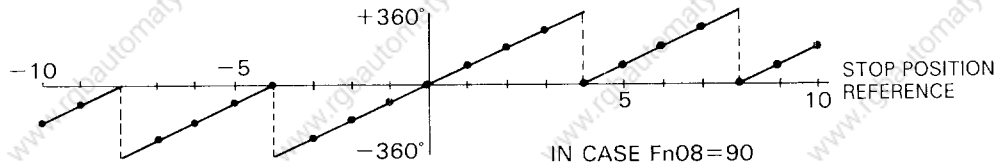

Fig. 41. 4 Stop Position Reference and Stop Position

41. 4. 4 Position Control Proportional Gain (Fn02, 03, 04)

Proportional gain can be set during orientation.

Proportional gain should be set high when in the region near the stop position. If the orientation end signal is not outputted or if it is late, being outputted. And it should be set low when vibration is present in the region near the stop position.

Positional loop gain, K_p ($1/\text{sec}$) is about one half the proportional gain constant.

41. 4. 5 Orientation Speed (Fn07)

Setting of orientation speed should be performed during stoppage of the system.

Orientation speed is dependent on spindle inertia (including motor shaft, etc.) and spindle torque.

Therefore, calculate the spindle inertia and spindle torque for the case of H-gear for each machine, and obtain the orientation speed from Fig. 41.5. Since this speed is the upper limit value, orientation speed may be set lower than the value shown in Fig. 41.5.

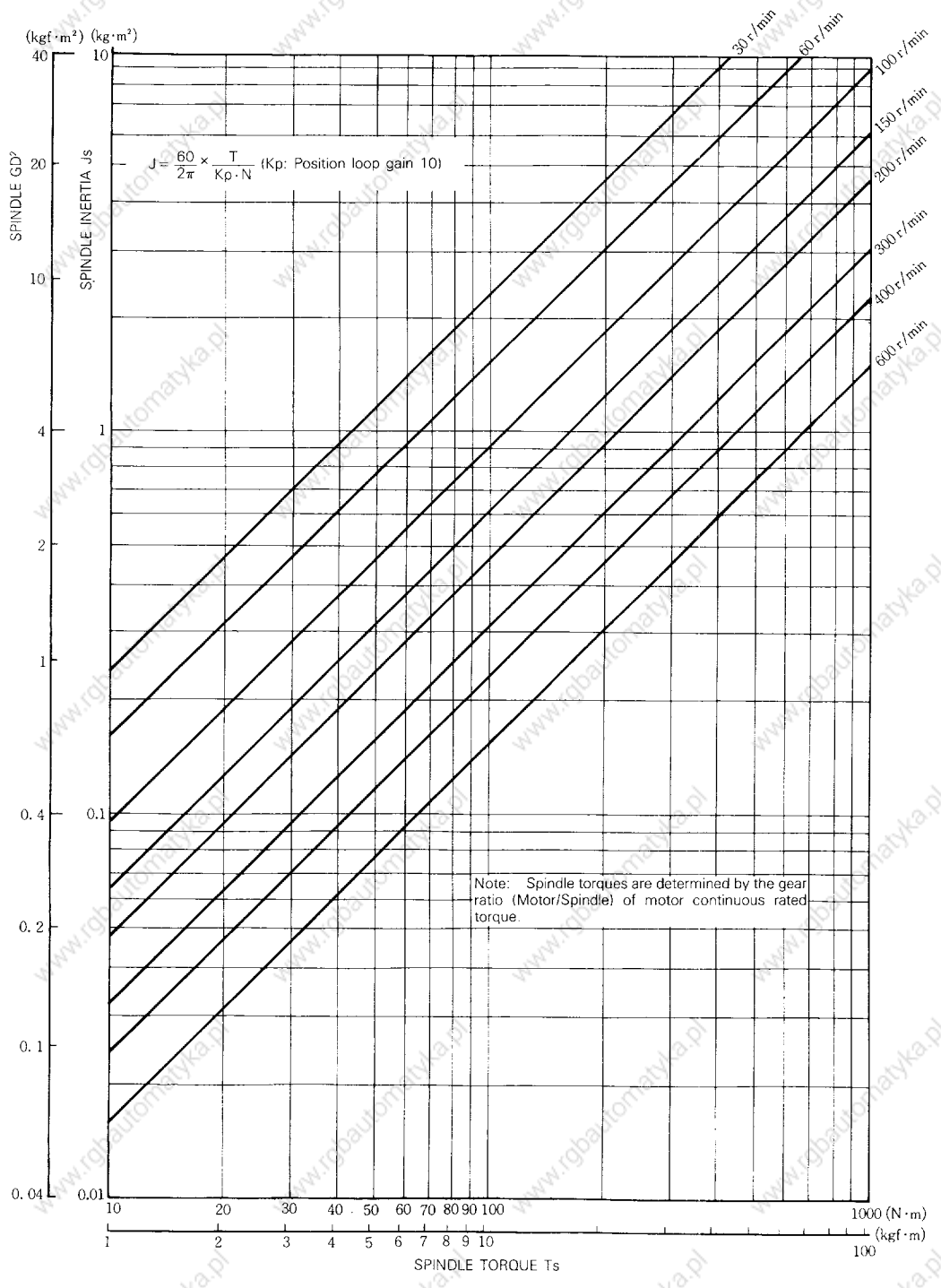

Fig. 41.5 Orientation Speed Setting

42. TROUBLESHOOTING

Should any trouble occur during operation, take appropriate measures after checking according to the procedure described in Table 42.1. Should the system fail to be restored, despite these measures taken, please contact our agent or our business office.

Table 42.1 Troubleshooting Method

Trouble Display and Trouble Condition	State		Probable Cause	Check Method	Corrective Action
	At Power ON	Test Mode Normal Mode			
Internal RAM error (F-1) External RAM error (F-2), PROM error (F-3),	○		Malfunction of control circuit.	Shut off the power supply, and after display LED has gone out charge the power source again.	If normal, restart the system.
			Orientation card defective.	(If you have any question, contact our agent or our business office.)	If an error is displayed again, change the orientation card.
NVRAM error (F-4), dA-0 dFAL bcc.E	○	○	Orientation card defective.	Contact our representative.	Replace the orientation card.
Encoder signal abnormal (F-8) (F-82),	○	○	Wrong setting of select connector.	Check the setting of connector against the list of setting classified by machine.	Change the setting of select connector.
			Encoder signal cable either disconnected or wrongly connected.	Check the encoder cable wiring.	Correct the wiring.
			Encoder defective.	Check the A-, B- and C-phase signals of encoder.	Replace the encoder.
C-phase pulse width abnormal (F-83)	○		Encoder C-phase signal defective.	Check the C-phase signal of encoder. 	Replace the encoder.
			Encoder signal cable characteristics defective.	Check the cable specifications.	Replace the encoder signal cable.
C-phase polarity error (F-84),	○		C-phase signal (PC,*PC) connected inversely.	Check the wiring of encoder signal cable.	Correct the wiring.
Incremental command error (Inc. F),	○	○	Power was charged with INC left in the ON state.	Carry out the same operation once again, and check the operating method from the setting panel and the LED of the orientation card.	After charging the power source to the system, change the operation sequence in such manner that the INC command is inputted only during stoppage.
			INC was turned on during spindle rotation (at 10 rpm or higher).		Either turn on switch (6) or carry out absolute positioning before inputting INC .
Spindle does not stop.	○	○	No orientation signal is inputted.	Identify the input signal from the controller setting panel. (Vn-07)	Input the orientation signal.
			Gear is selected incorrectly.		Correct selection of gear. (MGR. LGR).
	○	○	Setting of gear proportion is defective.	Identify the control constant from the setting panel. (Ln 22 to 24)	Change the control constants.
			A-and B-phase of encoder are inverse.	Run the spindle clockwise, and check from the spindle speed monitor. (See Par. 31.3.)	Interchange the A-and B-phase wiring.
	○	○	Encoder defective.	Check the A-, B- and C-phase signals of encoder.	Replace the encoder.

Table 42.1 Troubleshooting Method (Cont'd)

Trouble Display and Trouble Condition	State		Probable Cause	Check Method	Corrective Action
	At Power ON	Test Mode			
Orientation end signal is not outputted. (End of orientation is late.)		<input type="radio"/>	No orientation single is inputted.	Identify the input signal from the setting panel. (Fn-07)	Input the orientation signal.
		<input type="radio"/>	Switch (1) of S5 is in the ON (Test mode) state.	Identify the setting of S5.	Turn switch (1) off.
		<input type="radio"/>	Position control proportional gain is high.	Check for presence of vibration in the region near the stop position.	Adjust the proportional gain (Fn-02 to 04).
			Position control proportional gain is low.	Check if spindle is at a standstill in the region near the stop position.	
		Orientation card is defective.	Contact our agent or our business office.	Replace the orientation card.	
Stop Position Deviates		<input type="radio"/>	Wrong setting of external stop position command.	Check the position command data from data display. (Fn-0E)	Change the position command.
			Wrong setting of BCD and binray.	Check the setting on switch (4) of S5 against the setting list classified by machine.	Change the setting on switch (4).
			Wrong setting of BCD command resolution.	Check the control constant against the setting list classified by machine. (Fn-08)	Change the control constant.
			Wrong setting of reference point during incremental setting.	Check the setting on switch (6) of S5 against the setting list classified by machine.	Change the setting on switch (6).
		<input type="radio"/>	Wrong setting of the position of spindle origin.	Carry out positioning at the spindle origin, and measure the precision of the position.	Set the spindle origin all over again by carrying out setup operations.
		<input type="radio"/>	A-phase and B-phase of encoder are inverse to each other.	Run the spindle clockwise and check it from the spindle speed monitor. (See Par. 41.3.)	Replace the wirings between A-phase and B-phase.
		<input type="radio"/>	No setup operations are performed.	Check if stop position differs between the orientation from CW run and the orientation from CCW run.	Set the spindle origin all over again by carrying out setup operations.
	<input type="radio"/>	Characteristics of encoder signal cable defective.	Check the cable specifications.	Replace the encoder signal cable.	
		<input type="radio"/>	Motor and or controller are not grounded.	Carry out current continuity test to check if they are grounded.	Ground them correctly.

APPENDIX A HOW TO CALCULATE ACCELERATION AND DECELERATION TIME

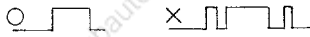
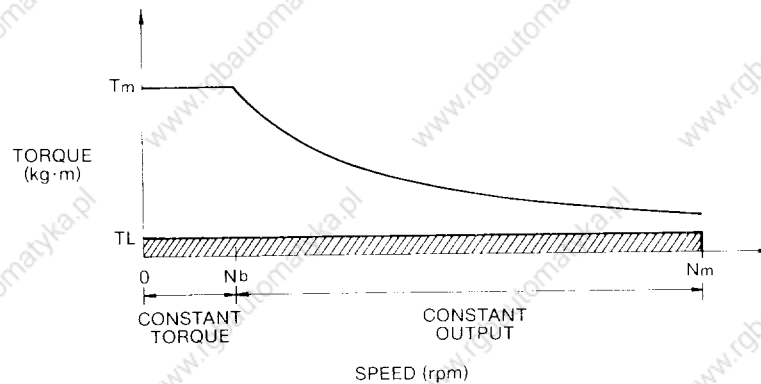

The spindle motor torque characteristics are as shown in the above figure.

When;

T_m : Maximum torque = 30-minute rated torque $\times 1.2$ (kg·m)

N_b : Base speed (r/min)

N_m : Maximum speed (r/min)

GD^2 : Motor GD^2 + Load GD^2 converted into motor shaft (kg·m²)

TL : Mechanical loss torque (kg·m)

can be calculated as follows.

(1) When $TL \cong 0$

(a) Acceleration and deceleration time for $0 \leftrightarrow N_b$

$$t_{ob} = \frac{GD^2 \cdot N_b}{375} \cdot \frac{1}{T_m} \text{ (sec)}$$

(b) Acceleration and deceleration time for $N_b \leftrightarrow N_m$

$$t_{bm} = \frac{GD^2}{750 \cdot T_m} \cdot \frac{N^2m - N^2b}{N_b} \text{ (sec)}$$

(c) Acceleration and deceleration time for $N_m \leftrightarrow 0$

$$t_{om} = \frac{GD^2}{750 \cdot T_m} \cdot \frac{N^2m + N^2b}{N_b} \text{ (sec)}$$

(2) When $T_L \neq 0$

(a) Acceleration time for $0 \rightarrow N_b$

$$t_{ob} = \int_0^{N_b} \frac{GD^2}{375 \times (T_m - T_L)} dN = \frac{GD^2 \times N_b}{375} \times \frac{1}{T_m - T_L} \text{ (sec)}$$

(b) Acceleration time for $N_b \rightarrow N_m$

$$t_{bm} = \int_{N_b}^{N_m} \frac{GD^2}{375 \left(\frac{N_b}{N} \cdot T_m - T_L \right)} dN$$
$$= \frac{GD^2}{375} \left\{ - \frac{N_m - N_b}{T_L} + N_b \cdot \frac{T_m}{T_L^2} \ln \frac{N_b (T_m - T_L)}{N_b \cdot T_m - N_m \cdot T_L} \right\} \text{ (sec)}$$

(c) Deceleration time for $N_m \rightarrow N_b$

$$t_{mb} = \frac{GD^2}{375} \left\{ \frac{N_m - N_b}{T_L} + N_b \cdot \frac{T_m}{T_L^2} \ln \frac{N_b (T_m + T_L)}{N_b \cdot T_m + N_m \cdot T_L} \right\} \text{ (sec)}$$

(d) Deceleration time for $N_b \rightarrow 0$

$$t_{bo} = \frac{GD^2 \cdot N_b}{375} \cdot \frac{1}{T_m + T_L} \text{ (sec)}$$

APPENDIX B HOW TO CALCULATE GD²

• GD² and Equivalent GD²

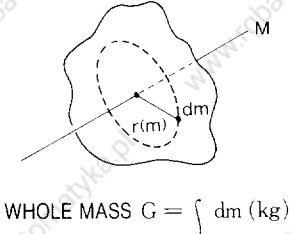
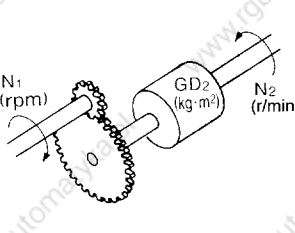
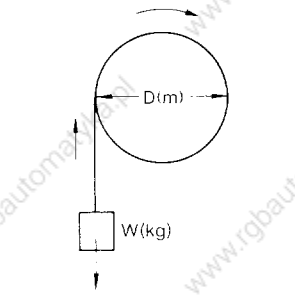
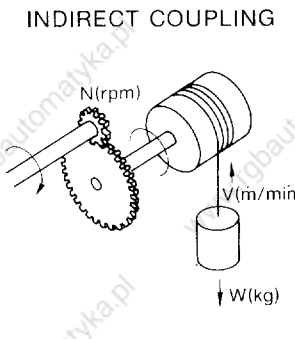
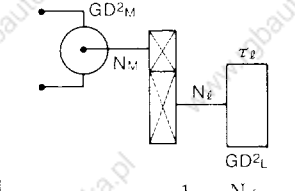
Item	Reference Figure	Formula
<p>Definition</p> <p>General</p>	 <p>WHOLE MASS $G = \int dm$ (kg)</p>	<ul style="list-style-type: none"> • Moment J of inertia about axis M. $J = \int r^2 dm$ [kg·m²] r: Distance from axis of rotation to infinitely small mass dm (m) • Moment J of inertia when whole mass G(kg) concentrates at radius k(m) of rotation. $J = Gk^2$ [kg·m²] $GD^2 = G(2k)^2 = 4J$ [kg·m²]
<p>Rotating Motion</p>		<ul style="list-style-type: none"> • Load GD² converted into shaft N₁ $GD^2_1 = GD^2_2 \times \left(\frac{N_2}{N_1}\right) = \frac{1}{a^2} GD^2_2$ GD²₁ = Equivalent GD² which is converted load GD² (GD²₂) into motor shaft (kg·m²) N₁ : Motor speed (r/min) N₂ : Load speed (r/min) $\frac{1}{a}$: Speed ratio = $\frac{N_2}{N_1}$
<p>Equivalent GD²</p> <p>Linear Motion</p>	<p>DIRECT COUPLING</p>  <p>INDIRECT COUPLING</p> 	<p>$GD^2 = WD^2$</p> <p>GD² : Equivalent GD² converted into axis of rotation (kg·m²) W : Weight of object (kg) D : Pulley diameter (m)</p> <p>$GD^2 = \left(\frac{1}{\pi}\right)^2 W \left(\frac{V}{N}\right)^2$ $= 0.101 \times W \left(\frac{V}{N}\right)^2$</p> <p>W : Weight of object (kg) V : Line speed (m/min) N : Motor speed (r/min)</p>
<p>Gear Ratio to minimize Starting Torque</p>	 <p>SPEED RATIO $\frac{1}{R} = \frac{N_L}{N_M}$</p>	<p>$R_0 = \sqrt{\frac{GD^2_M \cdot N_L}{375 t} + \tau_L}$</p> <p>GD²_M : Motor GD² (kg·m²) GD²_L : Load GD² (kg·m²) N_M : Motor speed (r/min) N_L : Load speed (r/min) τ_L : Load Torque (kg·m) t : Acceleration time (s)</p>

Note: When calculating equivalent GD² exactly, efficiency should be considered according to the direction of exerted force. (In the above table, $\eta=1$)

• **GD² of Simple Forms**

Diameter of rotation of simple forms*

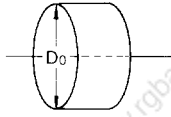
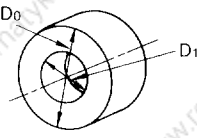
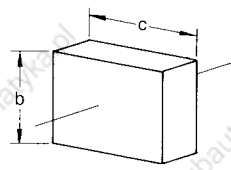
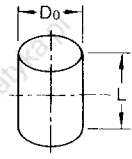
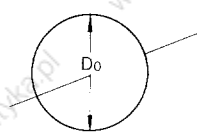
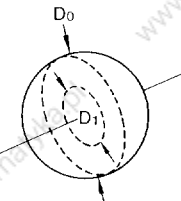
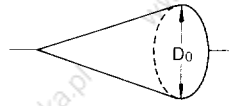
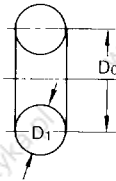
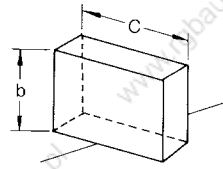
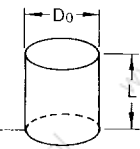
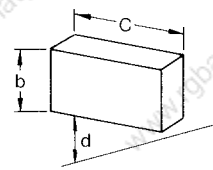
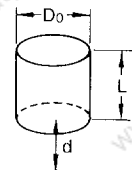
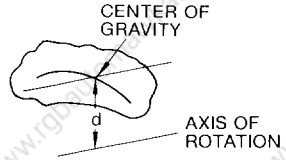
<ul style="list-style-type: none"> When axis of rotation equals center line of cylinder. 	<p>SOLID CYLINDER</p> $(D^2 = D_0^2 / 2)$ 	<p>HOLLOW CYLINDER</p> $D^2 = (D_0^2 + D_1^2) / 2$ 
	<p>RECTANGULAR PARALLELOPIPED</p> $D^2 = (b^2 + c^2) / 3$ 	<p>CYLINDER</p> $D^2 = L^2 / 3 + D_0^2 / 4$ 
<ul style="list-style-type: none"> When axis of rotation goes through the center of gravity. 	<p>SPHERE</p> $D^2 = \frac{2}{5} D_0^2$ 	<p>HOLLOW SPHERE</p> $D^2 = \frac{2}{5} \cdot \frac{D_0^5 - D_1^5}{D_0^3 - D_1^3}$ 
	<p>CONE</p> $D^2 = \frac{3}{10} D_0^2$ 	<p>CIRCLE</p> $D^2 = D_0^2 + \frac{3}{4} D_1^2$ 
<ul style="list-style-type: none"> When axis of rotation is at one end of body of rotation. 	<p>RECTANGULAR PARALLELOPIPED</p> $D^2 = (4b^2 + C^2) / 3$ 	<p>CYLINDER</p> $D^2 = \frac{4}{3} L^2 + \frac{D_0^2}{4}$ 
<ul style="list-style-type: none"> When axis of rotation is outside body of rotation. 	<p>RECTANGULAR PARALLELOPIPED</p> $D^2 = \frac{4b^2 + C^2}{3} + 4(bd + d^2)$ 	<p>CYLINDER</p> $D^2 = \frac{4}{3} L^2 + \frac{D_0^2}{4} + 4(dL + d^2)$ 
<ul style="list-style-type: none"> General formula when axis of rotation is outside body of rotation. 	<p>How to calculate diameter of rotation when axis of rotation is outside body of rotation.</p> $D_2^2 = D_1^2 + 4d^2$ <p>D_1 : Diameter of rotation when axis of rotation is temporarily considered to be the axis which is parallel to axis of rotation and goes through the center of gravity.</p> 	

*GD² = (Weight) × (Diameter of Rotation)²

Varispeed-626MTIII Drives

AC ADJUSTABLE SPEED DRIVES FOR MACHINE TOOL SPINDLES

3.7 TO 30 kW (5 TO 40 HP), 30-MINUTE OPERATION RATING

2.2 TO 22 kW (3 TO 60 HP), CONTINUOUS OPERATION RATING

TOKYO OFFICE Ontemachi Bldg, 1-6-1 Ontemachi, Chiyooa-ku, Tokyo, 100 Japan
Phone (03) 3284-9111 Telex YASKAWA J33530 Fax (03) 3284-9034

SEOUL OFFICE 8th Floor Seoul Center Bldg, 91-1, Sogong-Dong, Chung-ku, Seoul, Korea 100-070
Phone (02) 776-7844 Fax (02) 753-2639

TAIPEI OFFICE Shen Hsiang Tang Sung Chiang Building 10F 146 Sung Chiang Road, Taipei, Taiwan
Phone (02) 563-0010, -7732 Fax (02) 567-4677

YASKAWA ELECTRIC AMERICA, INC.

Chicago-Corporate Headquarters 2942 MacArthur Blvd, Northbrook, IL 60062-2028, U.S.A.
Phone (708) 291-2340 Fax (708) 498-2430

Chicago-Technical Center 3160 MacArthur Blvd, Northbrook, IL 60062-1917, U.S.A.

Phone (708) 291-0411 Fax (708) 291-1018

MOTOMAN INC.

805 Liberty Lane West Carrollton, OH 45449, U.S.A.

Phone (513) 847-6200 Fax (513) 847-6277

YASKAWA ELECTRIC EUROPE GmbH

Niederhöchstädter Straße 73, 61476 Kronberg-Oberhöchstädt, Germany

Phone (06173) 9380 Telex 415660 YASE D Fax (06173) 68421

YASKAWA ELÉTRICO DO BRASIL COMÉRCIO LTDA.

Rua Conde Do Pinhal 8-5, Andar Sala 51 CEP 01501-São Paulo-SP, Brasil

Phone (011) 35-1911 Fax (011) 37-7375

YASKAWA ELECTRIC (SINGAPORE) PTE. LTD.

Head Office : CPF Bldg, 79 Robinson Road # 13-05, Singapore 0106, SINGAPORE

Phone 221-7530 Telex (87) 24890 YASKAWA RS Fax 224-5854

Service Center : 221 Henderson Road, # 07-20 Henderson Building Singapore 0315, SINGAPORE

Phone 276-7407 Fax 276-7406

YATEC ENGINEERING CORPORATION

Shen Hsiang Tang Sung Chiang Building 10F 146 Sung Chiang Road, Taipei, Taiwan

Phone (02) 563-0010 Fax (02) 567-4677



YASKAWA

YASKAWA ELECTRIC CORPORATION