

Gear Units
R..7, F..7, K..7, S..7 Series, Spiroplan® W

Edition

05/2001

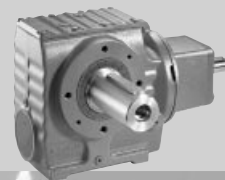

Operating Instructions



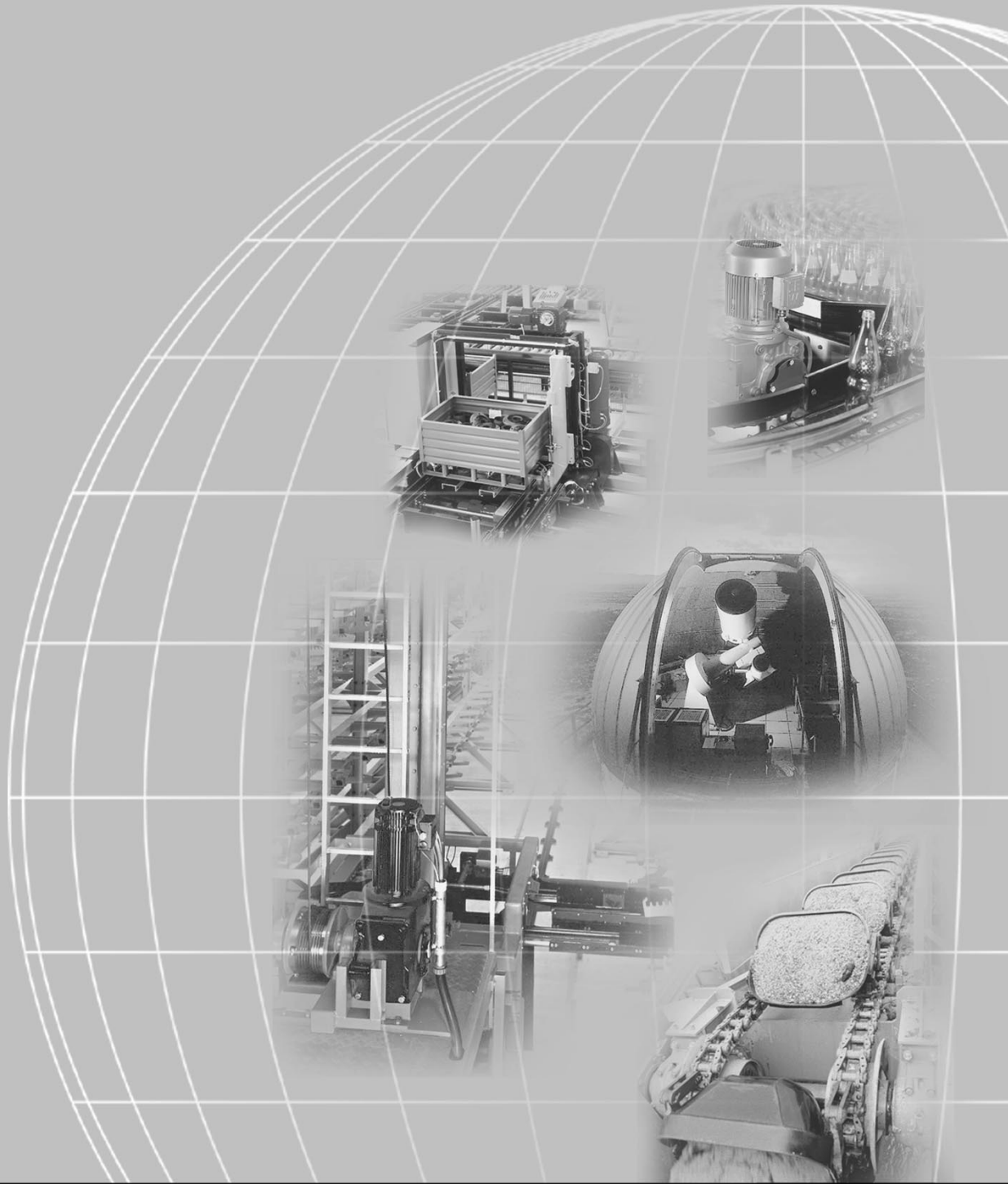



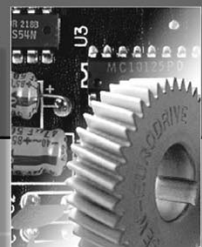

10503013 / EN



SEW-EURODRIVE





	1	Important Notes	4
	2	Safety Notes	5
	3	Gear Unit Design	7
	3.1	Basic design of a helical gear unit	7
	3.2	Basic design of a parallel shaft helical gear unit	8
	3.3	Basic design of a helical-bevel gear unit.....	9
	3.4	Base design of a helical-worm gear unit	10
	3.5	Basic design of a Spiroplan® gear unit	11
	4	Mechanical Installation	12
	4.1	Required tools / material	12
	4.2	Before you begin.....	12
	4.3	Preliminary work	12
	4.4	Installing the gear unit.....	13
	4.5	Gear units with solid shaft.....	15
	4.6	Installation of torque arms for shaft-mounted gear units.....	17
	4.7	Installation/removal of shaft-mounted gear units with key or splines.....	19
	4.8	Installation/removal of shaft-mounted gear units with shrink disc.....	23
	4.9	Installation of the AM adapter coupling.....	25
	4.10	Installation of the AQ adapter coupling.....	27
	4.11	Installation on the AD input shaft assembly	28
	5	Startup	30
	5.1	Startup of helical-worm and Spiroplan® W gear units.....	30
	5.2	Startup of helical, parallel shaft helical and helical-bevel gear units.....	30
	6	Troubleshooting	31
	6.1	Gear unit problems	31
	7	Inspection and Maintenance	32
	7.1	Inspection and maintenance periods	32
	7.2	Lubricant replacement schedule	32
	7.3	Inspection/maintenance of gear units	33
	8	Mounting Positions	34
	8.1	General comments on mounting positions.....	34
	8.2	Legend for mounting position pages.....	36
	8.3	Mounting positions, helical gear units	37
	8.4	Mounting positions, parallel shaft helical gear units.....	42
	8.5	Mounting positions, helical-bevel gear units	45
	8.6	Mounting positions, helical-worm gear units	50
	9	Lubricants	56
		Address List	62



1 Important Notes

Safety and warning notes

Please note the safety and warning notes in this publication!



Electrical hazard

Could result in: death or severe injuries.



Imminent danger

Could result in: death or severe injuries.



Dangerous situation

Could result in: slight or minor injuries.



Damaging situation

Could result in: damage of drive and operating environment.



Operating hints and useful information.



Close adherence to the Operating Instructions is the prerequisite for fault-free operation and fulfillment of any rights to claim under guarantee. Please start reading the Operating Instructions prior to operating the drive!

Keep Operating Instructions in vicinity of unit since it contains important information on service procedures.



- **Adjust lubricant fill amount and position of breather valve when changing mounting position (see section "Lubricants" and "Mounting Positions").**
- **Please see notes in section "Setup" / "Setup of Gear Unit!"**

Disposal



(please observe the most current regulations):

- Dispose of housing parts, gears, shafts and anti-friction bearing of gear units as steel scrap. The same applies to gray cast iron parts unless there is separate collection service.
- Some worm gears are made of non-ferrous metals and must be disposed of accordingly.
- Collect waste oil and dispose according to local guidelines.

Changes to edition 04/2000 are indicated by gray bars in the margin

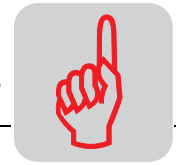

2 Safety Notes

Preliminary remarks

The following safety notes are principally concerned with the use of gear units.

If using **geared motors**, please also refer to the safety notes for motors in the corresponding operating instructions.

Please also take account of the supplementary safety notes in the individual chapters of these operating instructions.

General

During and after operation, geared motors and gear units have live and moving parts and their surfaces may be hot.

All work related to transport, putting into storage, setting up/mounting, connection, startup, maintenance and repair may only be carried out by qualified specialists in accordance with

- the corresponding detailed operating instructions booklet(s) and wiring diagrams
- the warning and safety signs on the gear unit/geared motor
- the specific regulations and requirements for the system and
- national/regional regulations governing safety and the prevention of accidents

Severe injuries and damage to property may result from

- incorrect use
- incorrect installation or operation
- removal of required protective covers or the housing when this is not permitted

Designated use

These geared motors/gear units are intended for industrial systems. They correspond to the applicable standards and regulations.

The technical data and the information about permitted conditions are to be found on the nameplate and in the documentation.

It is essential for all specified information to be observed!

Transportation / Storage

Inspect the delivered goods for any shipping damage as soon as you receive the delivery. Inform the shipping company immediately. It may be necessary to preclude startup.

Tighten installed transportation lugs firmly. They are only designed for the weight of the geared motor/gear unit; do not attach any additional loads.

The installed lifting eyebolts meet DIN 580. The loads and guidelines listed in the standard have to be observed. If there are two transportation or lifting eyebolts installed on the geared motor, you have to use both of them for transportation. The direction of the tensile force is not to exceed an angle of 45° to meet the guidelines set forth in DIN 580.

Use suitable, sufficiently rated handling equipment if necessary. Remove any transport fixtures prior to startup.

**Setup /
Installation**

See notes in sections "Setup" and "Installation/Removal!"

**Startup /
Operation**

Check whether the direction of rotation is correct in **decoupled** status (also listen out for unusual grinding noises as the shaft rotates).

Secure the shaft keys for test mode without output elements. Do not render monitoring and protection equipment inoperative even for test mode.

Switch off the geared motor if in doubt whenever changes occur in relation to standard operation (e.g. increased temperature, noise, vibration). Determine the cause; contact SEW if necessary.

**Inspection /
Maintenance**

See notes in section "Inspection/Maintenance!"



3 Gear Unit Design



The following illustrations represent design principles. They are merely reference tools for the spare parts lists. Deviations according to gear unit size and design are possible!

3.1 Basic design of a helical gear unit

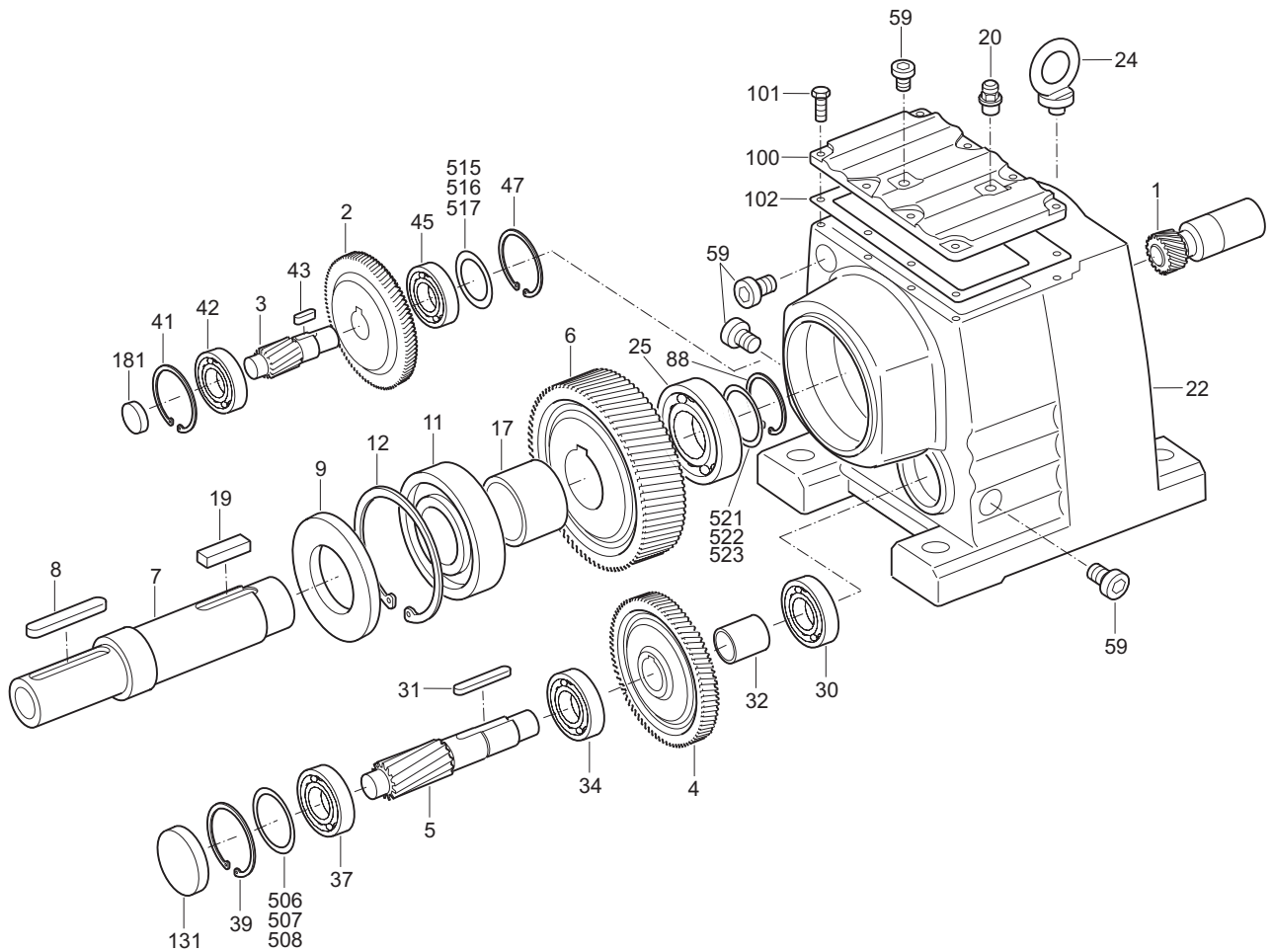

03438AXX

Fig. 1: Basic structure of helical gear units

Legend

1 Pinion	19 Key	42 Deep groove ball bearing	507 Shim
2 Gear	20 Breather valve	43 Key	508 Shim
3 Pinion shaft	22 Gear unit housing	45 Deep groove ball bearing	515 Shim
4 Gear	24 Lifting eyebolt	47 Circlip	516 Shim
5 Pinion shaft	25 Cylinder ball bearing	59 Screw plug	517 Shim
6 Gear	30 Deep groove ball bearing	88 Circlip	521 Shim
7 Output shaft	31 Key	100 Cover	522 Shim
8 Key	32 Spacer tube	101 Hex head screw	523 Shim
9 Oil seal	34 Cylinder ball bearing	102 Gasket	
11 Deep groove ball bearing	37 Deep groove ball bearing	131 Cap	
12 Circlip	39 Circlip	181 Cap	
17 Spacer tube	41 Circlip	506 Shim	



3.2 Basic design of a parallel shaft helical gear unit

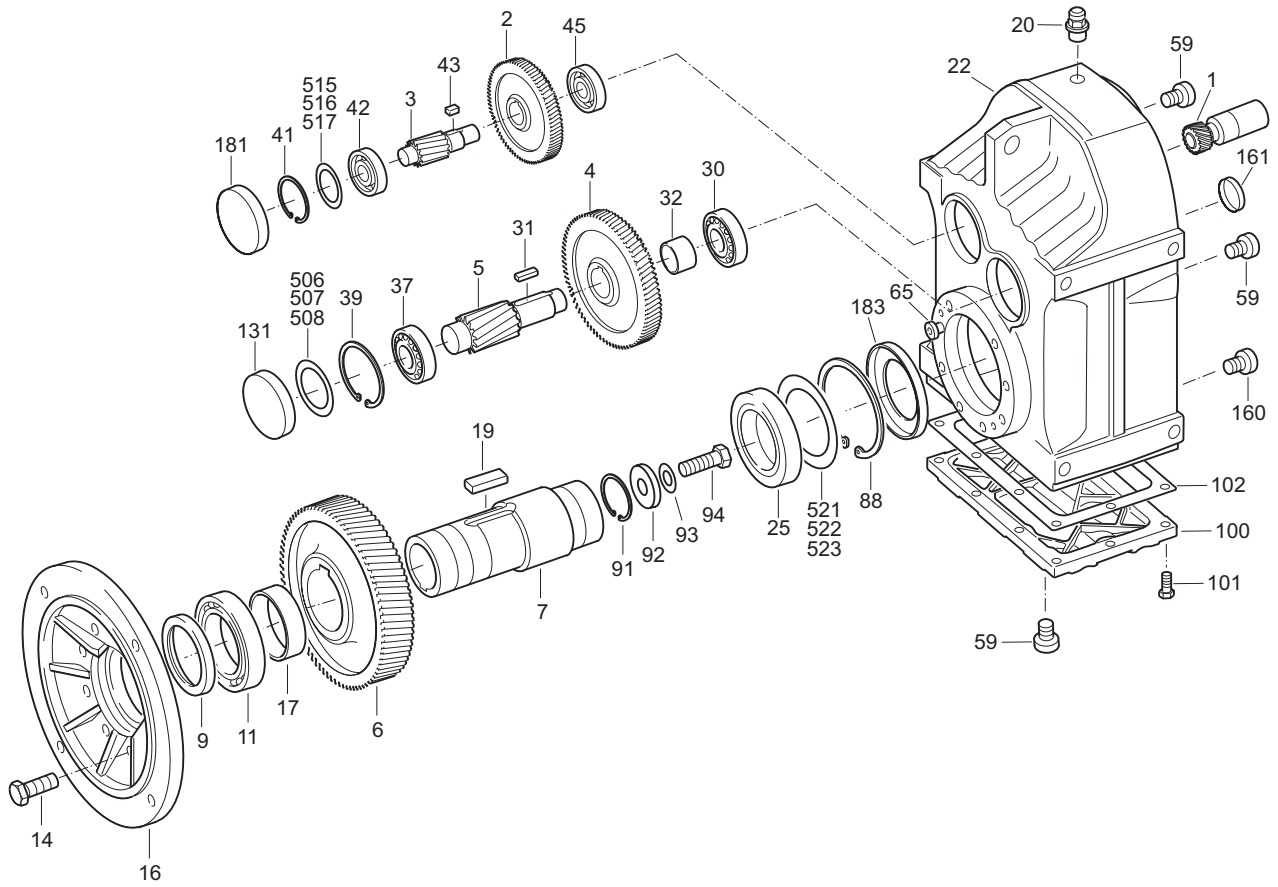

Fig. 2: Basic design of a parallel shaft helical gear unit

03469AXX

Legend

1 Pinion	22 Gear unit housing	91 Circlip	184 Oil seal
2 Gear	25 Deep groove ball bearing	92 Disc	506 Shim
3 Pinion shaft	30 Tapered roller bearing	93 Lock washer	507 Shim
4 Gear	31 Lockwasher	94 Hex head screw	508 Shim
5 Pinion shaft	32 Spacer tube	100 Cover	515 Shim
6 Gear	37 Tapered roller bearing	101 Hex head screw	516 Shim
7 Hollow shaft	39 Circlip	102 Gasket	517 Shim
9 Oil seal	41 Circlip	131 Cap	521 Shim
11 Deep groove ball bearing	42 Deep groove ball bearing	160 Plug	522 Shim
14 Hex head screw	43 Key	161 Cap	523 Shim
16 Output flange	45 Deep groove ball bearing	165 Plug	
17 Spacer tube	59 Screw plug	168 Protection cap	
19 Key	81 O-ring	181 Cap	
20 Breather valve	88 Circlip	183 Oil seal	



3.3 Basic design of a helical-bevel gear unit

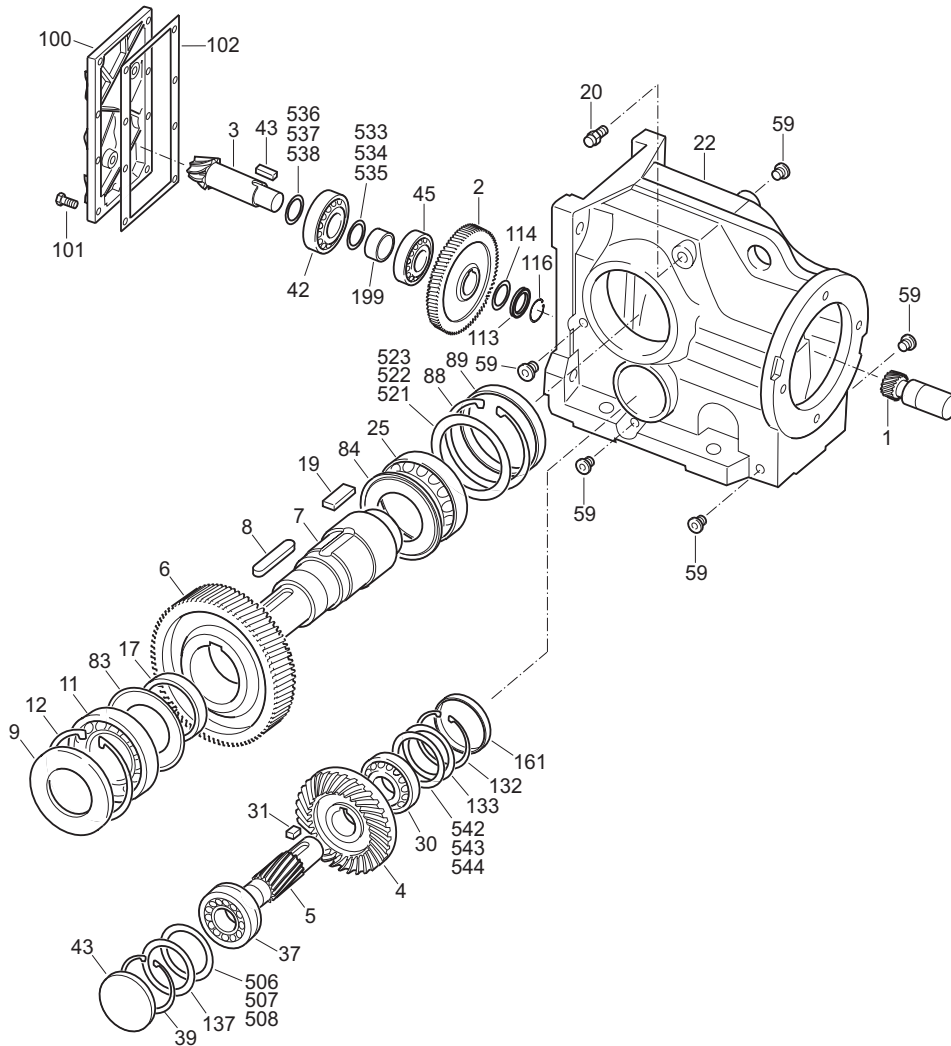

Fig.3: Basic design of a helical-bevel gear unit

03486AXX

Legend

1 Pinion	25 Tapered roller bearing	102 Adhesive and sealant	523 Shim
2 Gear	30 Tapered roller bearing	113 Wing nut	533 Shim
3 Pinion shaft	31 Key	114 Locking plate	534 Shim
4 Gear	37 Tapered roller bearing	116 Thread retention	535 Shim
5 Pinion shaft	39 Circlip	119 Spacer tube	536 Shim
6 Gear	42 Tapered roller bearing	131 Cap	537 Shim
7 Output shaft	43 Key	132 Circlip	538 Shim
8 Key	45 Tapered roller bearing	133 Spacer	542 Shim
9 Oil seal	59 Screw plug	137 Spacer	543 Shim
11 Tapered roller bearing	83 Nilos ring	161 Cap	544 Shim
12 Circlip	84 Nilos ring	506 Shim	
17 Spacer tube	88 Circlip	507 Shim	
19 Key	89 Cap	508 Shim	
20 Breather valve	100 Gear unit cover	521 Shim	
22 Gear unit housing	101 Hex head screw	522 Shim	



3.4 Base design of a helical-worm gear unit

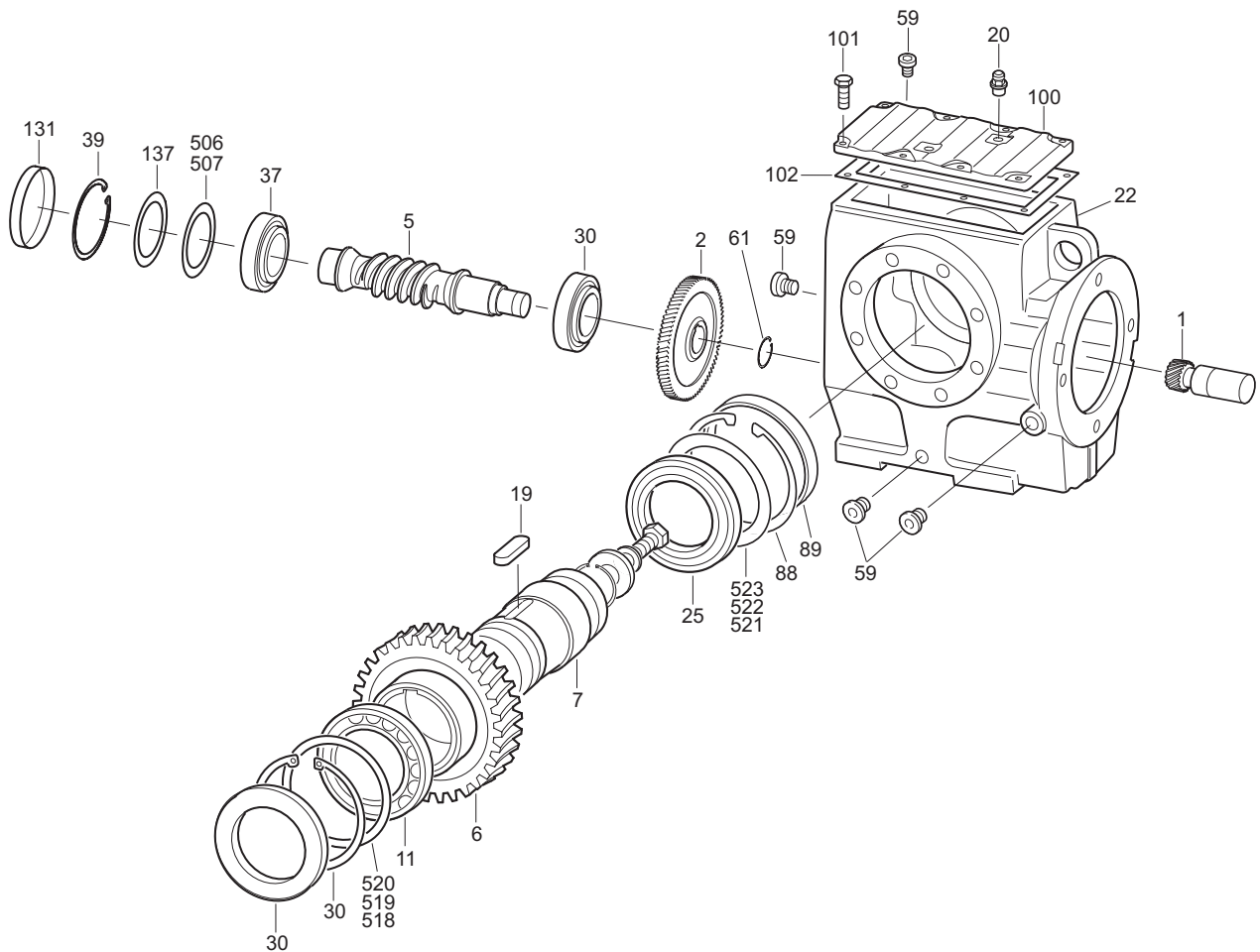

Fig. 4: Basic design of a helical-worm gear unit

03487AXX

Legend

1	Pinion	19	Key	61	Circlip	507	Shim
2	Gear	20	Breather valve	88	Circlip	518	Shim
5	Worm	22	Gear unit housing	89	Cap	519	Shim
6	Worm gear	25	Tapered roller bearing	100	Gear unit housing	520	Shim
7	Output shaft	30	Tapered roller bearing	101	Hex head screw	521	Shim
9	Oil seal	37	Tapered roller bearing	131	Cap	522	Shim
11	Tapered roller bearing	39	Circlip	137	Spacer	523	Shim
12	Circlip	59	Screw plug	506	Shim		



3.5 Basic design of a SPIROPLAN® gear unit

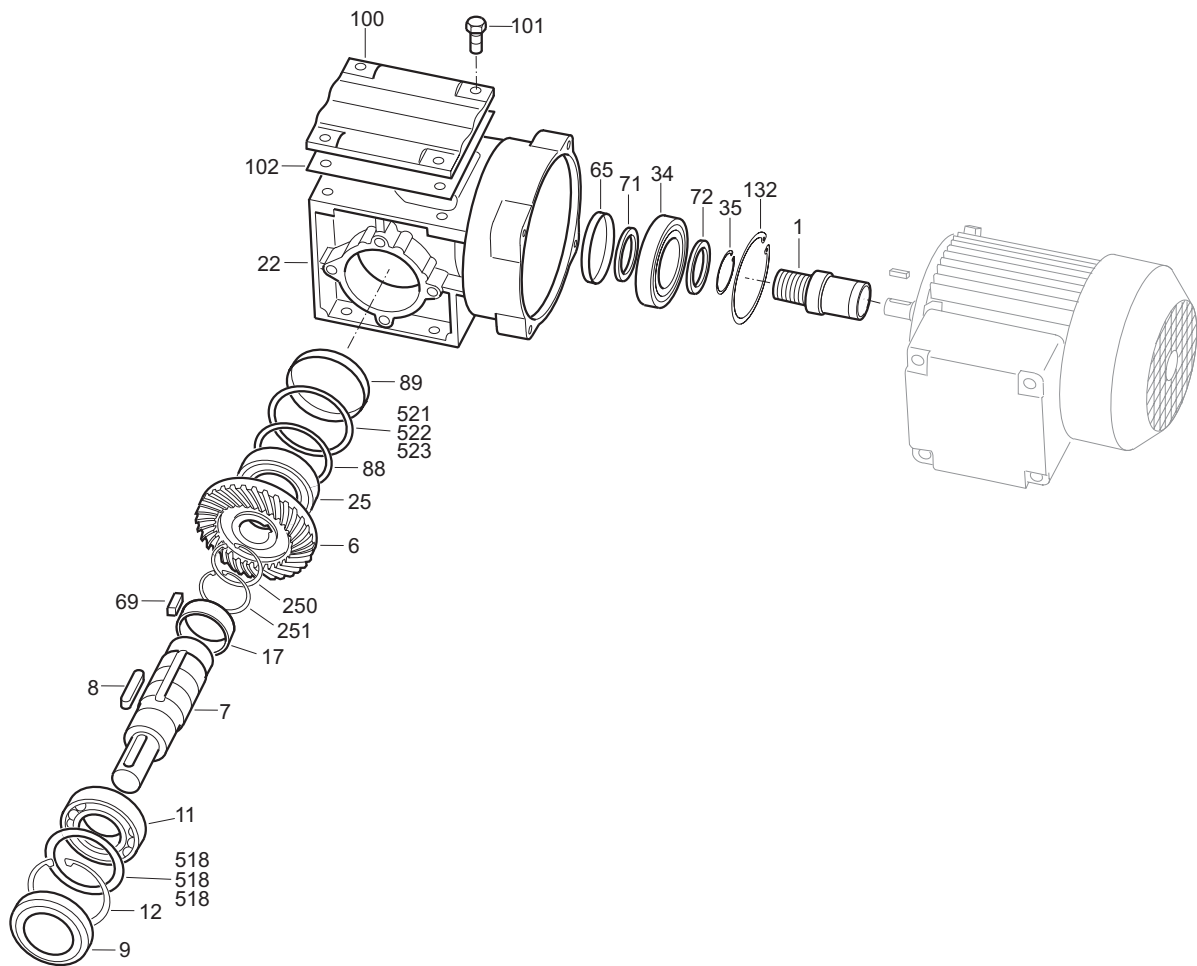

Fig. 5: Basic design of a SPIROPLAN® gear unit

03488AXX

Legend

1	Pinion	19	Key	88	Circlip	251	Circlip
6	Gear	22	Gear unit housing	89	Cap	518	Shim
7	Output shaft	25	Deep groove ball bearing	100	Gear unit cover	519	Shim
8	Key	34	Deep groove ball bearing	101	Hex head screw	520	Shim
9	Oil seals	35	Circlip	102	Gasket	521	Shim
11	Deep groove ball bearing	65	Oil seal	132	Circlip	522	Shim
12	Circlip	71	Spacer	183	Oil ring	523	Shim
17	Spacer tube	72	Spacer	250	Circlip		



4 Mechanical Installation

4.1 Required tools / material

- Set of spanners
- Torque wrench (for shrink discs, AQ motor adapter, input shaft assembly with centering shoulder)
- Mounting device
- Shims and distance rings, if necessary
- Fastening devices for input and output elements
- Lubricant (e.g. NOCO[®] fluid)
- Agent for securing screws, e.g. Loctite 243 (for input shaft assembly with centering shoulder)

Mounting tolerances

Shaft end	Flanges
Diameter tolerance according to DIN 748 <ul style="list-style-type: none"> • ISO k6 for solid shafts with $\varnothing \leq 50$ mm • ISO m6 for solid shafts with $\varnothing > 50$ mm • ISO H7 for hollow shafts • Center hole according to DIN 332, shape DR.. 	Centering shoulder tolerance according to DIN 42948 <ul style="list-style-type: none"> • ISO j6 with $b1 \leq 230$ mm • ISO h6 with $b1 > 230$ mm

4.2 Before you begin

The drive may only be installed if

- the entries on the name plate of the drive match the mains power supply,
- the drive is undamaged (no damage caused by transport or storage) and
- it is certain that the following requirements have been fulfilled:
 - **with standard gear units:**
ambient temperature according to lubricant table in section lubricants (see standard), no oil, acid, gas, vapors, radiation, etc.
 - **with special versions:**
drive configured in accordance with the ambient conditions
 - **with helical worm/Spiroplan[®] W gear units:**
no large external mass moments of inertia which could exert a retrodriving load on the gear unit
[where h' (retrodriving) = $2 - 1/\eta < 0.5$ self-locking]

4.3 Preliminary work

The output shafts and flange surfaces must be thoroughly cleaned of anti-corrosion agents, contamination or such like (use a commercially available solvent). Do not let the solvent come into contact with the sealing lips of the oil seals – material damage!

Long-term storage of gear units

Gear units of the “extended storage” type have

- a mineral oil fill (CLP) or synthetic oil fill (CLPHC) suitable for the mounting position so the unit is ready to run. However, you should still check the oil level prior to startup (see section "Inspection/Maintenance" / "Inspection/Maintenance work").
- a higher oil level with synthetic oil CLP PG). Correct the oil level prior to startup (see section "Inspection/Maintenance" / "Inspection/Maintenance work").

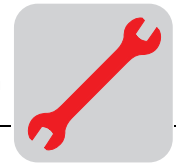

4.4 Installing the gear unit

The gear unit or geared motor must be mounted/installed in the specified mounting position on a level¹, vibration-absorbing and torsionally rigid support structure (Spiroplan® gear units are not dependent on mounting position). Do not tighten housing legs and mounting flanges against each other and pay attention to the approved overhung and axial loads

Use only bolts of 8.8 quality for installation of the geared motors

Use bolts of **10.9 quality** for fastening of flanges to transmit the rated torques listed in the catalog for the following helical geared motors in flange design (RF..) and in foot/flange version (R..F):

- RF37, R37F with flange-Ø 120 mm
- RF47, R47F with flange-Ø 140 mm
- RF57, R57F with flange-Ø 160 mm



Oil check screws, drain screws and breather valves have to be freely accessible!

At this point of assembly, please check that the oil filling is as prescribed for the mounting position (see "Lubricants" / "Lubricant fill levels" or data on nameplate). **In case of mounting position change, adjust lubricant filling quantities accordingly.**

Please consult our service department, if the mounting position for K gear units is changed to M5 or M6 or within these mounting positions.

Please consult our service department, if the mounting position of S units in sizes S47 ... S97 is to be changed to mounting position M2.

Use plastic inserts (2 – 3 mm thick) if there is a risk of electrochemical corrosion between the gear unit and the driven machine (connection between different metals such as cast iron and high-grade steel)! Also fit the bolts with plastic washers! Ground the housing additionally – use the grounding bolts on the motor.

Gear units are supplied in corrosion-resistant versions for use in damp areas or in the open air. Any damage to the paintwork (e.g. on the breather valve) must be repaired.

Installation in damp areas or in the open

1. Maximum permitted flatness error for flange mounting (approximate values with reference to DIN ISO 1101): with → flange 120...600 mm max. error 0.2...0.5 mm

**Gear unit venting**

No ventilation is required for R17, R27 and F27 gear units in mounting positions M1, M3, M5 and M6 as well as Spiroplan® W gear units.

All other gear units are delivered by SEW ready for the mounting position with the breather valve and transport fixture fitted.

Exceptions:

Gear units for long-term storage, in pivoting or inclined mounting positions are supplied with a screw plug installed in the provided vent hole. Prior to startup, the customer must replace screw plug at the highest location by the supplied breather valve.

- **With geared motors** for long-term storage, pivoting or inclined mounting positions, the supplied breather valve is located in the **motor terminal box**.
- **With gear head units** that have to be vented on the input side, the breather valve is supplied in a plastic bag.
- **No breather valve** will be supplied **for gear units in enclosed design**.

Activating the breather valve

Usually the breather valve is activated in the plant. Should this not be the case, the transport fixture must be removed from the breather valve prior to the startup of the gear unit!

1. Breather valve with transport fixture
2. Remove transport fixture
3. Activate breather valve

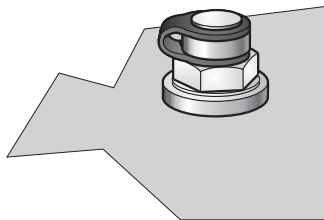

02053BXX

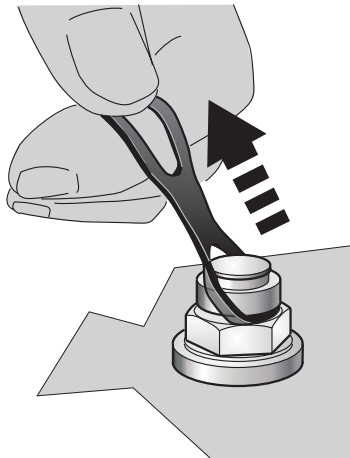

02054BXX

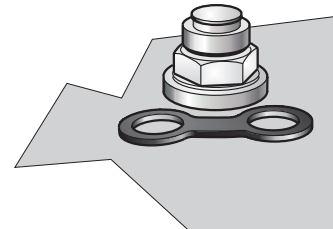

02055BXX

Painting the gear unit

Cover breather valve and oil seals with protective tape prior to painting or partly repainting the drive. Remove adhesive strips when the paint job is finished.



4.5 Gear units with solid shaft

Installation of input and output elements

The following illustration is an example of a mounting device for mounting couplings or hubs onto gear unit or motor shaft ends. It may be possible to dispense with the thrust bearing on the mounting device.

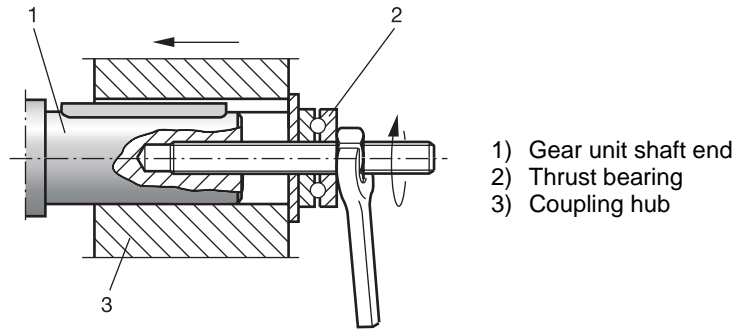

- 1) Gear unit shaft end
- 2) Thrust bearing
- 3) Coupling hub

03371BXX

The following illustration displays the correct mounting arrangement **B** of a gear wheel or sprocket to prevent excessively high overhung loads.

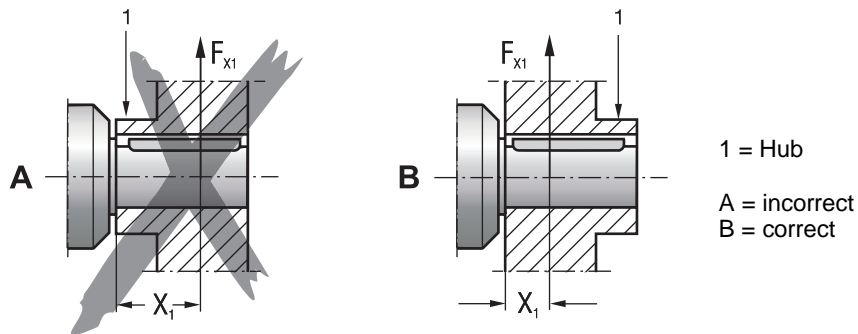

03369BXX

- Only use a mounting device (see Fig. 1) for installing input and output elements. Use the center bore and the thread on the shaft end for positioning purposes.
- **Never drive belt pulleys, couplings, pinions, etc. onto the shaft end by hitting them with a hammer (damage to bearings, housing and the shaft!).**
- **In the case of belt pulleys, make sure the belt is tensioned correctly (in accordance with the manufacturer's instructions).**
- Power transmission elements should be balanced after fitting and must not give rise to any impermissible radial or axial forces (see Fig. 2 / permitted values see the "Geared Motors" catalog).



Note:

Assembly is easier if you first apply lubricant to the output element or heat it up briefly (to 80-100 °C).

**Installation of couplings**

Harmonize the following factors according to the manufacturer's recommendation when installing couplings:

- a) maximum and minimum distance
- b) axial misalignment
- c) angular misalignment

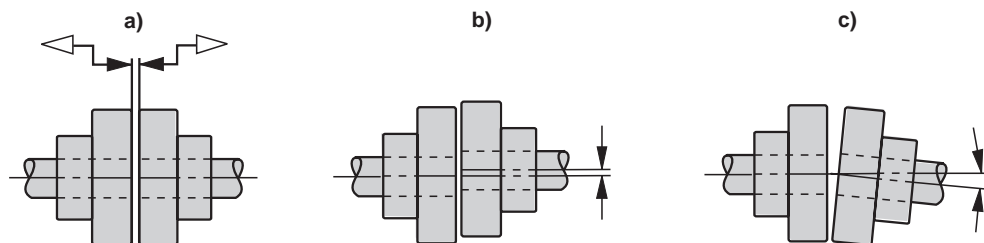
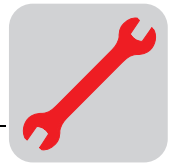

Fig. 6: Distance and misalignment with coupling installation

03356AXX



Drive and output elements such as belt pulleys, couplings, etc. must be equipped with a touchguard!



4.6 Installation of torque arms for shaft-mounted gear units

Do not strain torque arms during installation!

Parallel shaft helical gear units

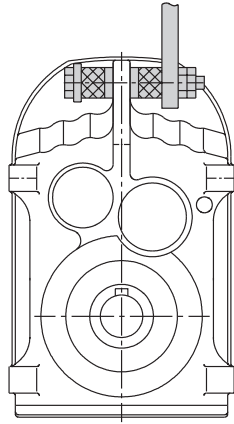

01029BXX

Fig. 7: Torque arm for parallel shaft gear units

Helical-bevel gear units

- Bushing with bearings on both ends → (1)
- Install connection end B as a mirror image of A

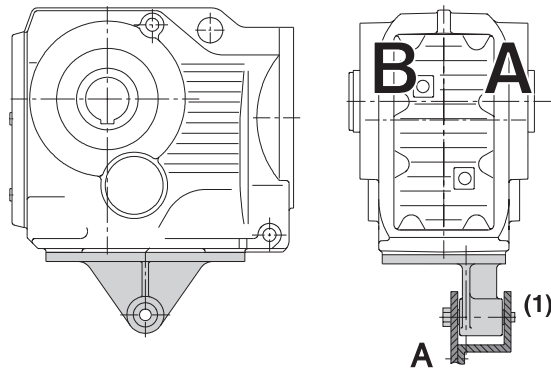

01030CXX

Fig. 8: Torque arm for helical-bevel gear units



Helical-worm gear units

- Bushing with bearings on both ends → (1)

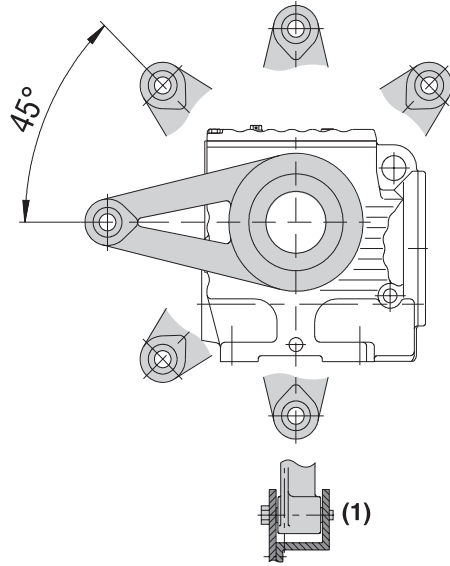

01031CXX

Fig. 9: Torque arm for helical-worm gear units

SPIROPLAN® W gear units

- Bushing with bearings on both ends → (1)

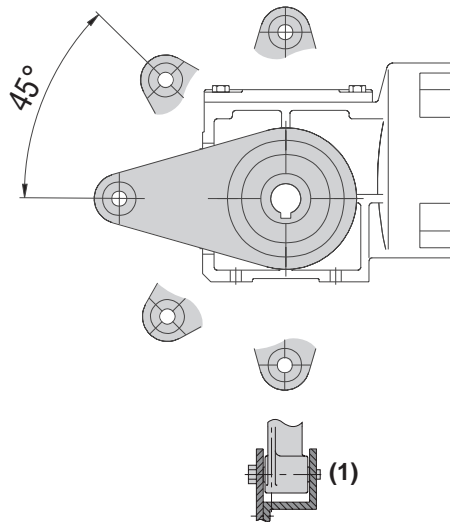

02050CXX

Fig. 10: Torque arm for SPIROPLAN® W gear units



4.7 Installation/removal of shaft-mounted gear units with key or splines



Note the construction notes in the Geared Motors catalog when designing the customer shaft!

Installation notes

1. Apply NOCO® fluid

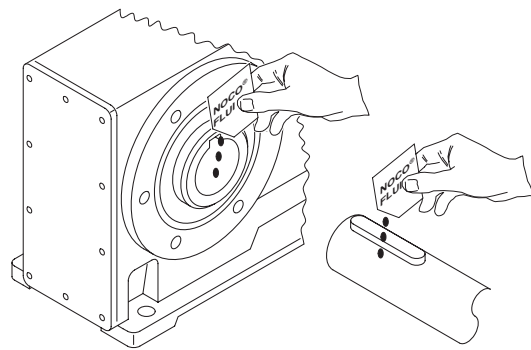

02042BXX

2. Distribute NOCO® fluid evenly

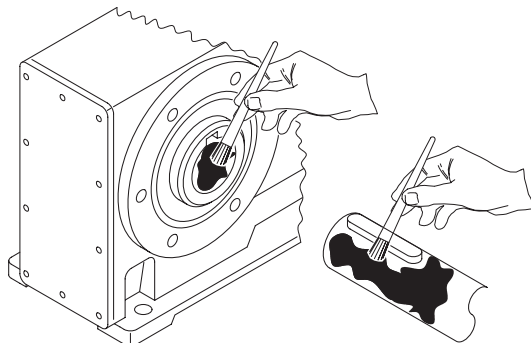

02043AXX

3. Install shaft and secure axially
(installation will be made easier by using a mounting device)

3A: Installation with standard components

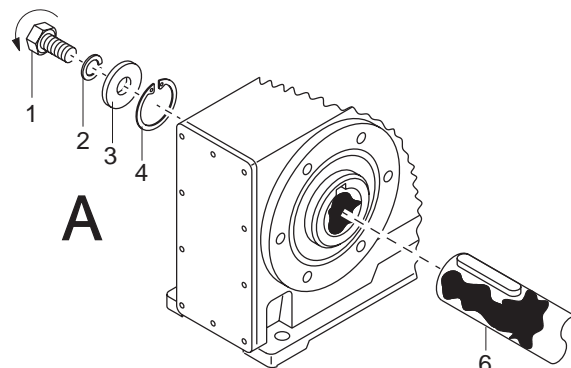

- 1 short retaining screw
(standard components)
- 2 lock washer
- 3 washer
- 4 circlip
- 6 customer shaft

03361BXX



3B: Installation with SEW installation/removal kit (→ page 22)

– Customer shaft **with** contact shoulder

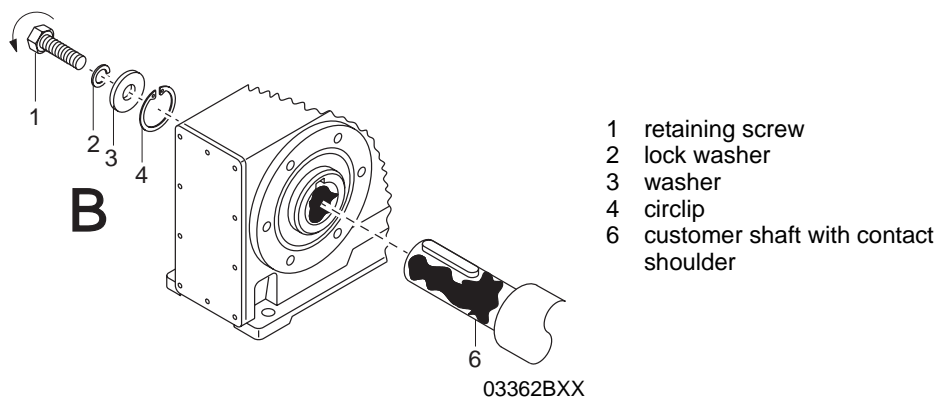

3C: Installation with SEW installation/removal kit (→ page 22)

– Customer shaft **without** contact shoulder

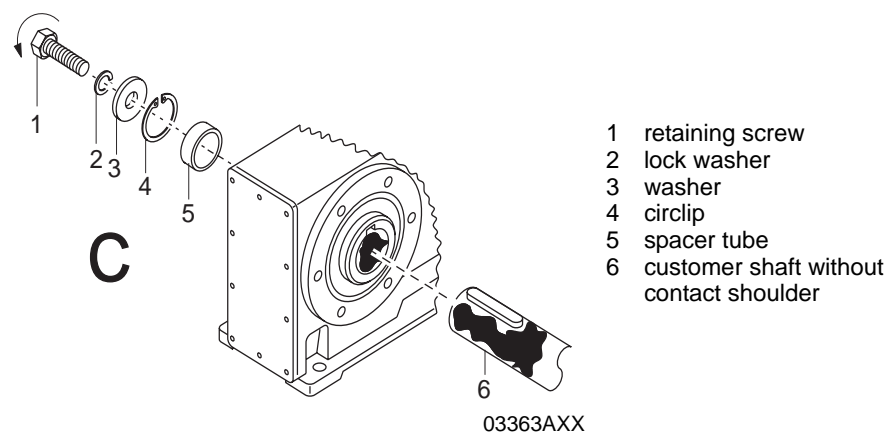

4. Tighten retaining screw with corresponding torque (see table).

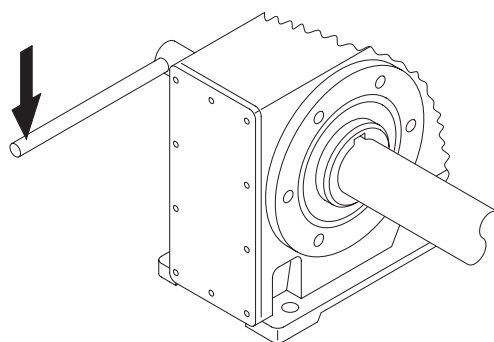

Screw	Torque [Nm]
M5	5
M6	8
M10/12	20
M16	40
M30	80
M24	200



Note:

We recommend you also loosen the customer shaft between the two contact surfaces to prevent contact corrosion!



Removal notes

The description applies only to gear units that were installed with the SWE mounting/removal kit (→ page 22) (see previous description, points 3B or 3C)

1. Loosen the retaining screw 1.
2. Remove parts 2 to 4 and the spacer tube 5, if installed.

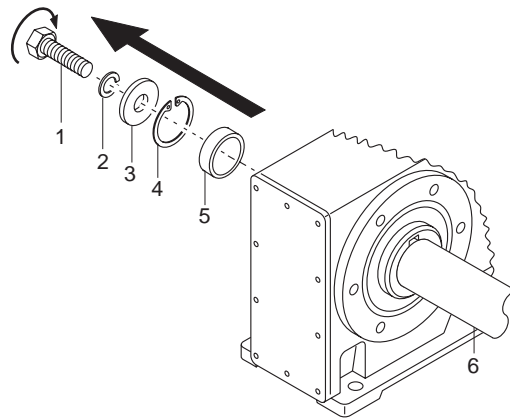

- 1 retaining screw
- 2 lock washer
- 3 washer
- 4 circlip
- 5 spacer tube
- 6 customer shaft

03366AXX

3. Install the removal washer 8 and the locknut 7 from the SEW installation/removal kit between customer shaft 6 and circlip 4.
4. Reinstall the circlip 4.
5. Reinstall the retaining screw 1. You can now remove the gear unit from the shaft by tightening the screw.

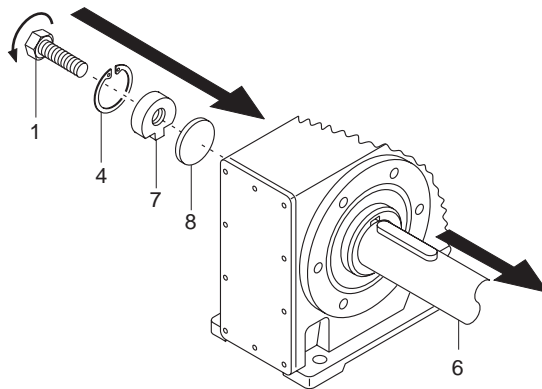

- 1 retaining screw
- 4 circlip
- 6 customer shaft
- 7 locknut
- 8 removal washer

03367AXX

**SEW installation/
removal kit**

The SEW installation/removal kit is available with the indicated part number.

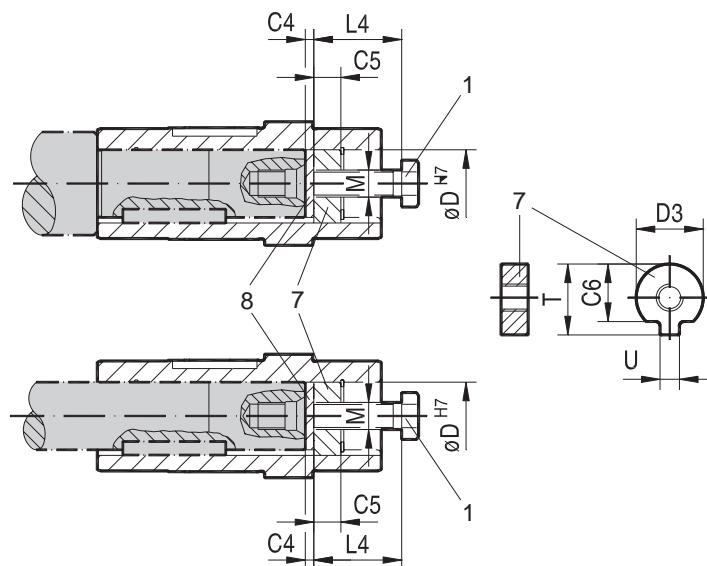

Fig. 11: SEW installation/removal kit

03394CXX

- 1 retaining screw
- 7 locknut for removal
- 8 removal washer

Type	D ^{H7} [mm]	M ¹⁾	C4 [mm]	C5 [mm]	C6 [mm]	U ^{-0.5} [mm]	T ^{-0.5} [mm]	D ^{3-0.5} [mm]	L4 [mm]	Part number installation/ removal kit
WA..10	16	M5	5	5	12	4.5	18	15.7	50	643 712 5
WA..20	18	M6	5	6	13.5	5.5	20.5	17.7	25	643 682 X
WA..20, WA..30, SA..37	20	M6	5	6	15.5	5.5	22.5	19.7	25	643 683 8
FA..27, SA..47	25	M10	5	10	20	7.5	28	24.7	35	643 684 6
FA..37, KA..37, SA..47, SA..57	30	M10	5	10	25	7.5	33	29.7	35	643 685 4
FA..47, KA..47, SA..57	35	M12	5	12	29	9.5	38	34.7	45	643 686 2
FA..57, KA..57, FA..67, KA..67, SA..67	40	M16	5	12	34	11.5	41.9	39.7	50	643 687 0
SA..67	45	M16	5	12	38.5	13.5	48.5	44.7	50	643 688 9
FA..77, KA..77, SA..77	50	M16	5	12	43.5	13.5	53.5	49.7	50	643 689 7
FA..87, KA..87, SA..77, SA..87	60	M20	5	16	56	17.5	64	59.7	60	643 690 0
FA..97, KA..97, SA..87, SA..97	70	M20	5	16	65.5	19.5	74.5	69.7	60	643 691 9
FA..107, KA..107, SA..97	90	M24	5	20	80	24.5	95	89.7	70	643 692 7
FA..127, KA..127	100	M24	5	20	89	27.5	106	99.7	70	643 693 5
FA..157, KA..157	120	M24	5	20	107	31	127	119.7	70	643 694 3

1) retaining screw



4.8 Installation/removal of shaft-mounted gear units with shrink disc

Installation notes

- Do not tighten locking screws unless shaft is installed - hollow shaft could be deformed!

1. Thoroughly remove grease from hollow shaft bore and drive shaft.
2. Degreased hollow shaft/drive shaft

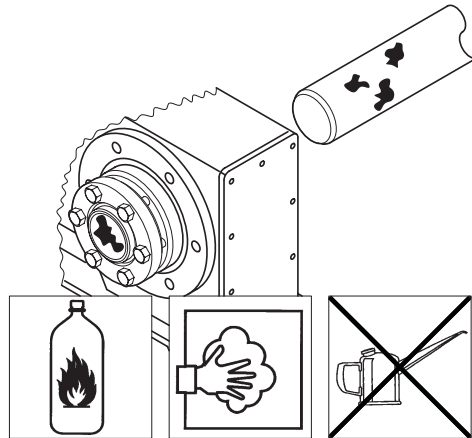

01815AXX

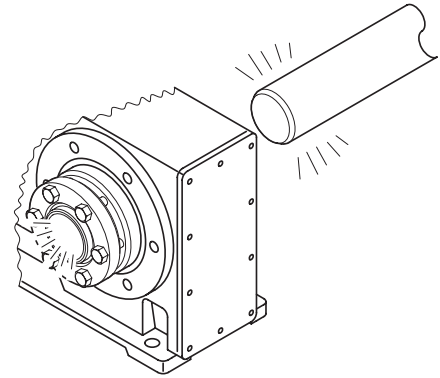

01816AXX

3. Apply NOCO® fluid in the bushing area onto the input shaft¹⁾.
4. Install shaft, making sure that the locking collars of the shrink disc are evenly spaced²⁾.

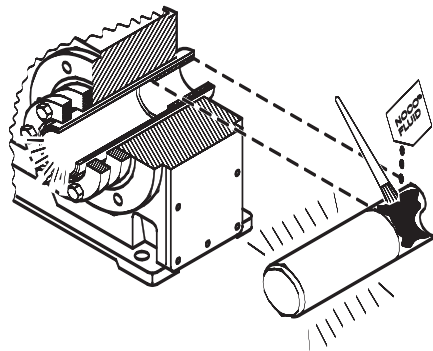

01817AXX

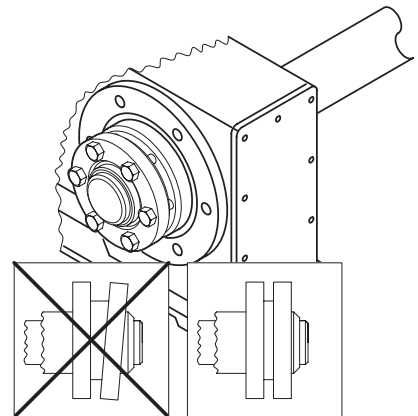

01818AXX



- 1) **The clamping area of the shrink disc must always be kept free from grease! Therefore, never apply NOCO® fluid directly onto the bushing, since the paste can enter the clamping area of the shrink disc when installing the input shaft.**
- 2) **After installation**, grease the outer surface of the hollow shaft in the shrink disc area to protect the shaft against corrosion.



5. Tighten the locking screws by working round several times from one screw to the next (not diagonally). See table for tightening torques.

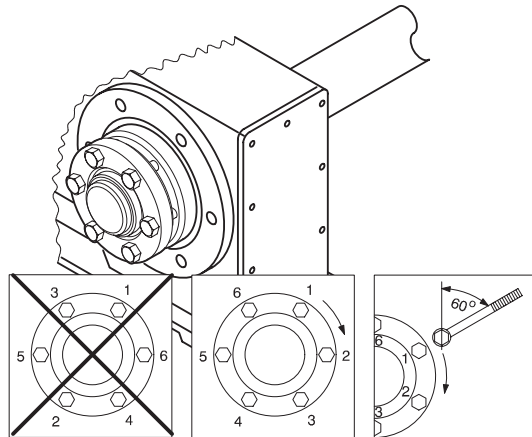

01819AXX

Gear unit type			Screw	Nm	max. ¹⁾	
	FH27	SH37	M5	5	60°	
	KH37...77	FH37...77	SH47...77	M6		12
	KH87/97	FH87/97	SH87/97	M8		30
	KH107	FH107	M10	59		
	KH127/157	FH127	M12	100		

1) maximum tightening angle per cycle

Notes on removal of shrink disc

1. Unscrew the locking screws evenly one after the other. To avoid tilting and jamming of the locking collars, each locking screw may only be unscrewed by about one quarter turn in the initial cycle. Do not fully unscrew the locking screws!
2. Remove the shaft or pull the hub off the shaft (it is necessary to remove any rust which may have formed between the hub and the end of the shaft).
3. Pull the shrink disc off the hub..



Caution!

There is a risk of injuries if the shrink disc is not removed correctly!

Cleaning and lubricating the shrink disc

There is no need to take apart and re-grease disassembled shrink discs before they are screwed back on.

The shrink disc only needs to be cleaned and re-greased if it is contaminated.

Use one of the following solid lubricants for the tapered surfaces.

Lubricant (Mo S2)	Available as
Molykote 321 (lube coat)	spray
Molykote Spray (powder spray)	spray
Molykote G Rapid	spray or paste
Aemasol MO 19P	spray or paste
AemasolDIO-sétral 57 N (lube coat)	spray

Grease the locking screws with a multipurpose grease such as Molykote BR 2 or similar.



4.9 Installation of the AM adapter coupling

IEC adapters
AM63 - 225 /
NEMA adapters
AM56 - 365

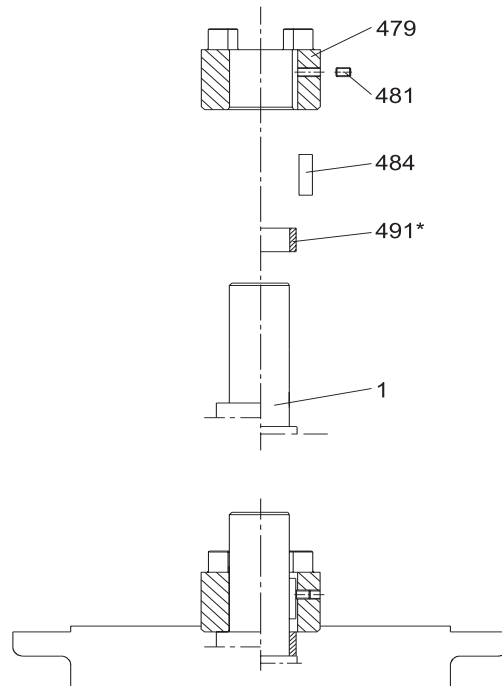

* = NEMA adapters only
 1 = motor shaft

04469AXX

1. Clean motor shaft and flange surfaces of motor and adapter.
2. **IEC adapters:** Remove motor shaft key and replace with supplied key (484).
NEMA adapters: Remove motor shaft key, slide spacer tube (491) on motor shaft and install supplied key (484).
3. Heat coupling half (479) to approx. 80 - 100°C; slide coupling half on motor shaft.
IEC adapters: until rest on motor shaft shoulder.
NEMA adapters: until rest on spacer tube.
4. Secure key and coupling half with setscrew (481) on motor shaft .
5. Mount motor to adapter; the gearing of the coupling half and the geared adapter shaft must enmesh.



Note: We recommend applying Noco[®] fluid on the motor shaft prior to installation of the coupling half to prevent contact corrosion.



**IEC adapters
AM250/AM280**

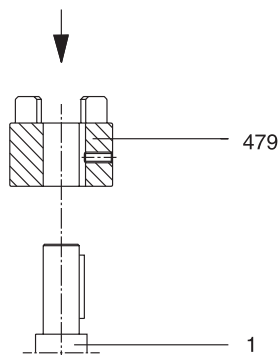

1 = Motor shaft
2 = Setscrew

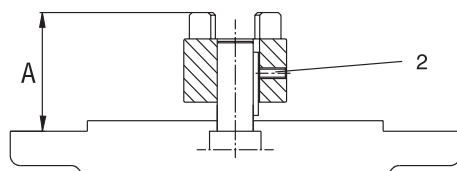

02047CXX

1. Clean motor shaft and flange surfaces of motor and adapter.
2. Remove motor shaft key and replace with supplied key (**size AM280 only**).
3. Heat coupling half (479) (to 80 °C - 100 °C) and slide on motor shaft (A = 139 mm).
4. Fasten coupling half with setscrew and check position (distance "A").
5. Mount motor on adapter; the gearing of the coupling half and the geared adapter shaft must enmesh.



Note: We recommend applying Noco[®] fluid on the motor shaft prior to installation of the coupling half to prevent contact corrosion.

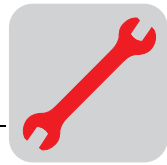

4.10 Installation of the AQ adapter coupling

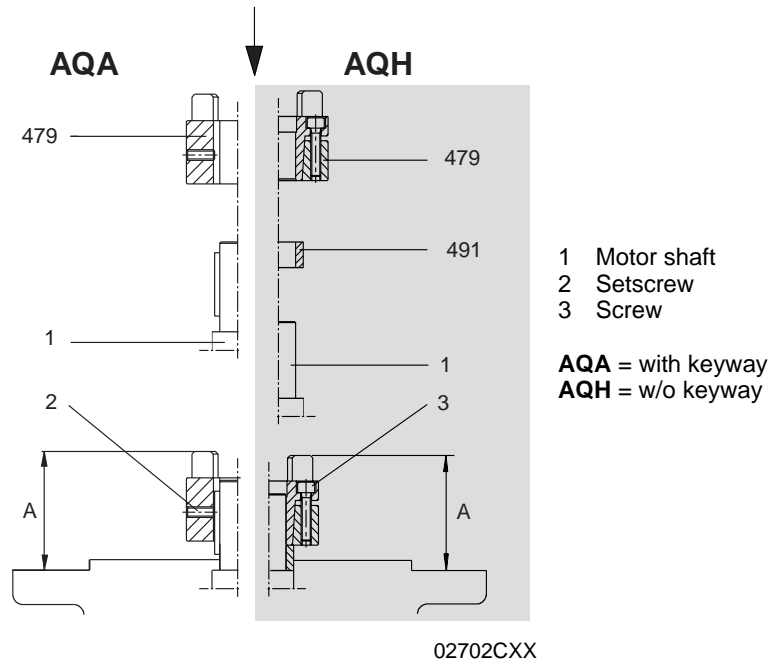

1. Clean motor shaft and flange surfaces of motor and adapter.
2. **AQH design:** Slide spacer tube (491) on motor shaft.
3. **AQH design:** Loosen screws of coupling half (479) and conical connection.
4. Heat coupling half (80° C - 100° C) and slide on motor shaft.
 - AQH design:** until rest on spacer tube (491).
 - AQA design:** until distance "A" (see table)
5. **AQH design:** Fasten screws of coupling half evenly by working round several times in sequence until all screws have been tightened to the TT tightening torque.
 - AQA design:** Secure coupling half with setscrew.
6. Check position of coupling half (distance "A" see table).

Mount motor to adapter; the jaws of both coupling halves must enmesh. The insertion force required to join the coupling halves. The insertion force required to join the coupling halves is suspended after final assembly thereby causing danger of axial load on the adjacent bearing.

Setting dimensions, tightening torques

Type	Coupling size	Distance "A" [mm]	Bolts DIN 912 ¹⁾	Tightening torque TT ¹⁾ [Nm]
AQA /AQH 80 /1/2/3	19/24	44.5	M4	3
AQA /AQH 100 /1/2		39		
AQA /AQH 100 /3/4		53		
AQA /AQH 115 /1/2		62		
AQA /AQH 115 /3	24/28	62	M5	6
AQA /AQH 140 /1/2		62		
AQA /AQH 140 /3	28/38	74.5	M5	6
AQA /AQH 190 /1/2		76.5		
AQA /AQH 190 /3	38/45	100	M6	10

1) in versions without keyway only (AQH)



4.11 Installation on the AD input shaft assembly

See section "Installation of input and output shafts" for installation of input elements.

**Version with
motor mounting
platform AD../P**

Installation of motor and adjustment of motor mounting platform

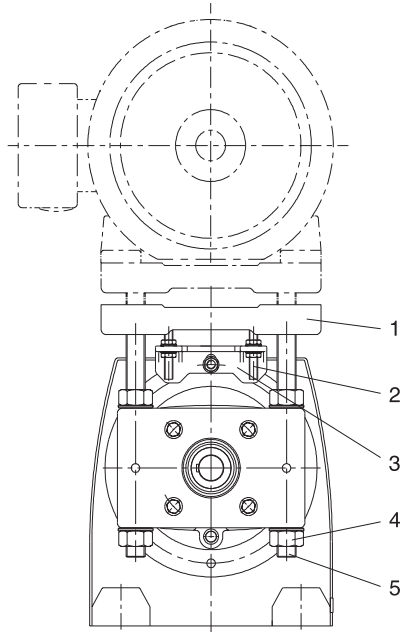

- 1 Motor mounting platform
- 2 Setscrew (AD6/P / AD7/P only)
- 3 Support (AD6/P / AD7/P only)
- 4 Nut
- 5 Threaded column

03519BXX

1. Adjust motor mounting platform to required mounting position by evenly tightening the adjusting nuts. For the lowest possible adjustment position of helical gear units, remove eyebolts/transport lugs if there are any; touch up any damage to protective coating.
2. Align motor on motor mounting plate (shaft extensions must be aligned) and secure it.
3. Mount drive elements onto input shaft extension and install motor shaft, align these to each other; correct motor position where necessary.
4. Install traction mechanisms (V-belts, chains, ...) and tighten by evenly adjusting the motor mounting plate. The motor mounting plate and columns must not be tightened against each other.
5. Secure threaded columns with the nuts not used for adjustment purposes.

**AD6/P and AD7/P
only:**

Loosen nuts and stud bolts before readjustment so that the stud bolts can be moved freely in the support axially. Tighten nuts after the final position has been accomplished. Do not adjust the motor mounting platform by using the support.

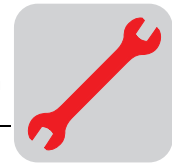

AD../ZR design with centering shoulder

Installing components on the input shaft assembly with centering shoulder

1. The bolts must be available in the correct length to fasten the installed components.
The length of the new bolts results from:

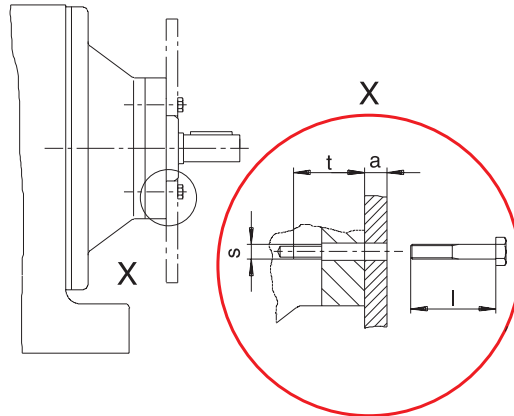

$l = t + a$
 t screw depth (see table)
 a thickness of application
 s retaining thread (see table)

02725CXX

The calculated screw length must be rounded down to the next smallest standard length.

2. Remove retaining screw from centering shoulder.
3. Clean contact surface and centering shoulder.
4. Clean the threads of the new screws and apply an adhesive agent (e.g. Loctite 243) to the first turns on the screw.
5. Set component onto centering shoulder and fasten retaining screws with indicated tightening torque T_t (see table).

Type	Depth of screw t	Retaining thread s	Tightening torque T_A [Nm]
AD2/ZR	25.5	M8	25
AD3/ZR	31.5	M10	48
AD4/ZR	36	M12	86
AD5/ZR	44	M12	86
AD6/ZR	48.5	M16	210
AD7/ZR	49	M20	410
AD8/ZR	42	M12	86

AD../RS version with backstop

Check the direction of rotation prior to installation or startup. In case of the wrong direction of rotation, please consult our technical department.

The backstop is maintenance-free and does not require any additional maintenance work.



5 Startup

5.1 Startup of helical-worm and Spiroplan® W gear units



Note: The direction of rotation for the output shaft has been changed from CW to CCW for helical-worm gear units S..7 series compared to the S..2 series. Switch two motor feeder cables to change the direction of rotation.

Running-in period

Spiroplan® and helical-worm gear units require a running-in period of at least 24 hours before reaching their maximum efficiency. A separate running-in period is required for each direction of rotation if the gear unit is operated in both directions of rotation. The table displays the average power reduction during the running-in period.

No. of starts	Helical-worm		Spiroplan®	
	power reduction	i range	power reduction	i range
1 start	approx. 12%	app. 50...280	approx. 15%	approx. 40...75
2 starts	approx. 6%	app. 20...75	approx. 10%	approx. 20...30
3 starts	approx. 3%	app. 20...90	approx. 8%	approx. 15
4 starts	-	-	approx. 8%	approx. 10
5 starts	approx. 3%	app. 6...25	approx. 5%	approx. 8
6 starts	approx. 2%	app. 7...25	-	-

5.2 Startup of helical, parallel shaft helical and helical-bevel gear units

There are no special startup notes that have to be observed for helical gear units, parallel shaft helical gear units and helical-bevel gear units, if the gear units have been mounted according to the section "Mechanical Installation."



6 Troubleshooting

6.1 Gear unit problems

Problem	Possible cause	Remedy
Unusual, regular running noise	A Meshing/grinding noise: bearing damage B Knocking noise: irregularity in the gearing	A Check oil (see Inspection and Maintenance), replace bearing B Call customer service
Unusual, irregular running noise	Foreign bodies in the oil	<ul style="list-style-type: none"> Check oil (see Inspection and Maintenance) Stop the drive, call customer service
Oil leaking ¹⁾ <ul style="list-style-type: none"> from the gear unit cover from the motor flange from motor oil seal from gear unit flange from the output end oil seal 	A Defective rubber gasket on gear unit cover B Defective gasket C Gear unit not vented	A Retighten screws on gear unit cover and observe gear unit. Oil still leaking: Call customer service B Call customer service C Vent the gear unit (see Mounting Positions)
Oil leaking from the breather valve	A Too much oil B Drive installed in incorrect mounting position C Frequent cold starts (oil foaming) and / or high oil level	A Correct oil level (see Inspection and Maintenance) B Fit the breather valve correctly (see Mounting Positions) and adjust oil level (see Lubricants)
Output shaft is not rotating although the motor is running or the input shaft is rotating	Shaft hub connection interrupted in the gear unit	Send in gear unit/geared motor for repair

1) It is normal for small amounts of oil/grease to leak out of the oil seal during the running-in period (24 hour running time) (also see DIN 3761).

Please have the following information available if you require assistance of our customer service:

- Nameplate data (complete)
- Type and extent of problem
- Time and circumstances of problem
- Possible cause



7 Inspection and Maintenance

7.1 Inspection and maintenance periods

Time period	What to do?
<ul style="list-style-type: none"> every 3000 operating hours, at least every six months 	<ul style="list-style-type: none"> Check oil
<ul style="list-style-type: none"> depending on operating conditions (see following illustration), at least every three years 	<ul style="list-style-type: none"> Replace mineral oil Replace bearing grease
<ul style="list-style-type: none"> depending on operating conditions (see following illustration), at least every five years 	<ul style="list-style-type: none"> Replace synthetic oil Replace bearing grease
<ul style="list-style-type: none"> R17, R27, F27 and Spiroplan® gear units are lubricated for life and do not require maintenance 	
<ul style="list-style-type: none"> different (depending on external influences) 	<ul style="list-style-type: none"> Touch up or replace surface/corrosion protection coat

7.2 Lubricant replacement schedule

Change oil more often in special version and under more demanding/aggressive ambient conditions!

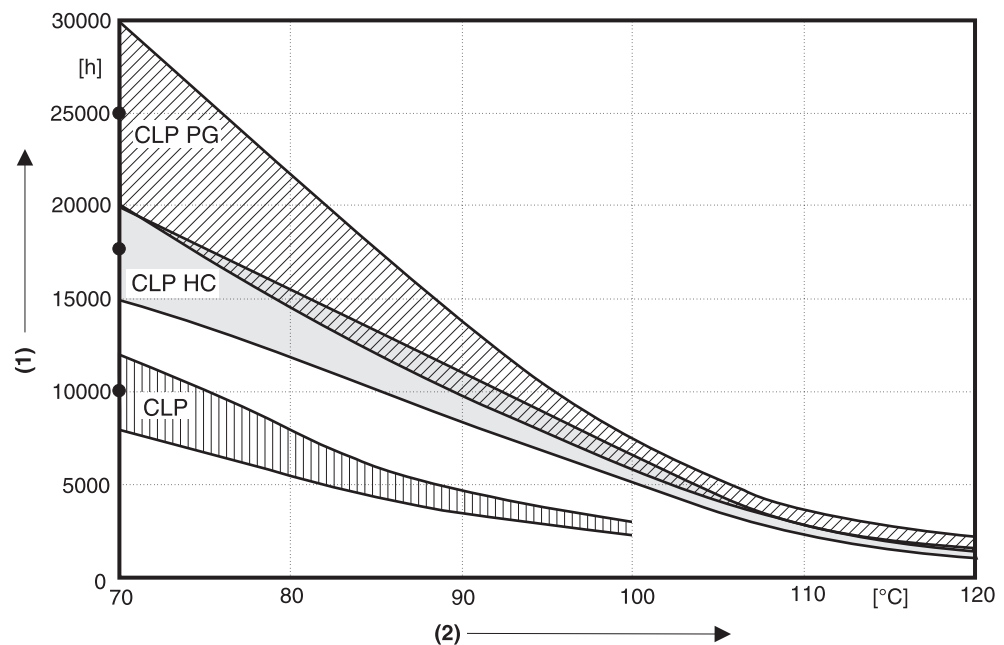

04640AXX

Fig. 12: Replacement schedule for standard gear units operating under normal ambient conditions.

- (1) Operating hours
 (2) Oil bath steady-state temperature
- Average value depending on oil type at 70° C



7.3 Inspection/maintenance of gear units

Do not mix synthetic lubricants with each other nor with mineral lubricants!
Mineral oil is the standard lubricant.

The position of the oil level plug, oil drain plug and the breather valve is dependent on the mounting position.

Checking the oil level



1. **De-energize the drive and secure against unintentional switch-on!**
Wait until the gear unit has cooled down – Danger of burns!
2. See section "Setup of gear unit" for change in mounting position!
3. For gear units with oil level plug: remove oil level plug, check fill level and correct if necessary, install oil level plug

Check oil



1. **De-energize the drive and secure against unintentional switch-on!**
Wait until gear unit has cooled down - Danger of burns!
2. Remove some oil from the oil drain plug
3. Check oil consistency
 - viscosity
 - if the oil is visibly contaminated, it is recommended to change it sooner than recommended by the maintenance intervals listed under the heading "Inspection and maintenance periods" on page 32
4. For gear units with an oil level plug: remove oil level plug, check oil fill level and correct if necessary, install oil level plug

Changing the oil



- Only change the oil when the gear unit is at operating temperature.
1. **De-energize the drive and secure against unintentional switch-on!**
Wait until the gear unit has cooled down – Danger of burns!
Note: Gear unit must still be warm, otherwise the high viscosity of excessively cold oil will make it harder to drain the oil correctly.
 2. Place a container underneath the oil drain plug
 3. Remove oil level plug, breather plug/valve and oil drain plug
 4. Drain oil completely
 5. Install oil drain plug
 6. Fill new oil of the same type through the breather hole, otherwise consult our service department
 - amount in accordance with the mounting position (see section "Lubricant fill levels") on the nameplate
 - check at the oil level plug
 7. Install oil level plug
 8. Install breather plug/valve

8 Mounting Positions

8.1 General comments on mounting positions

Mounting position designation

SEW has six mounting positions M1 ... M6 for gear units (see illustration).

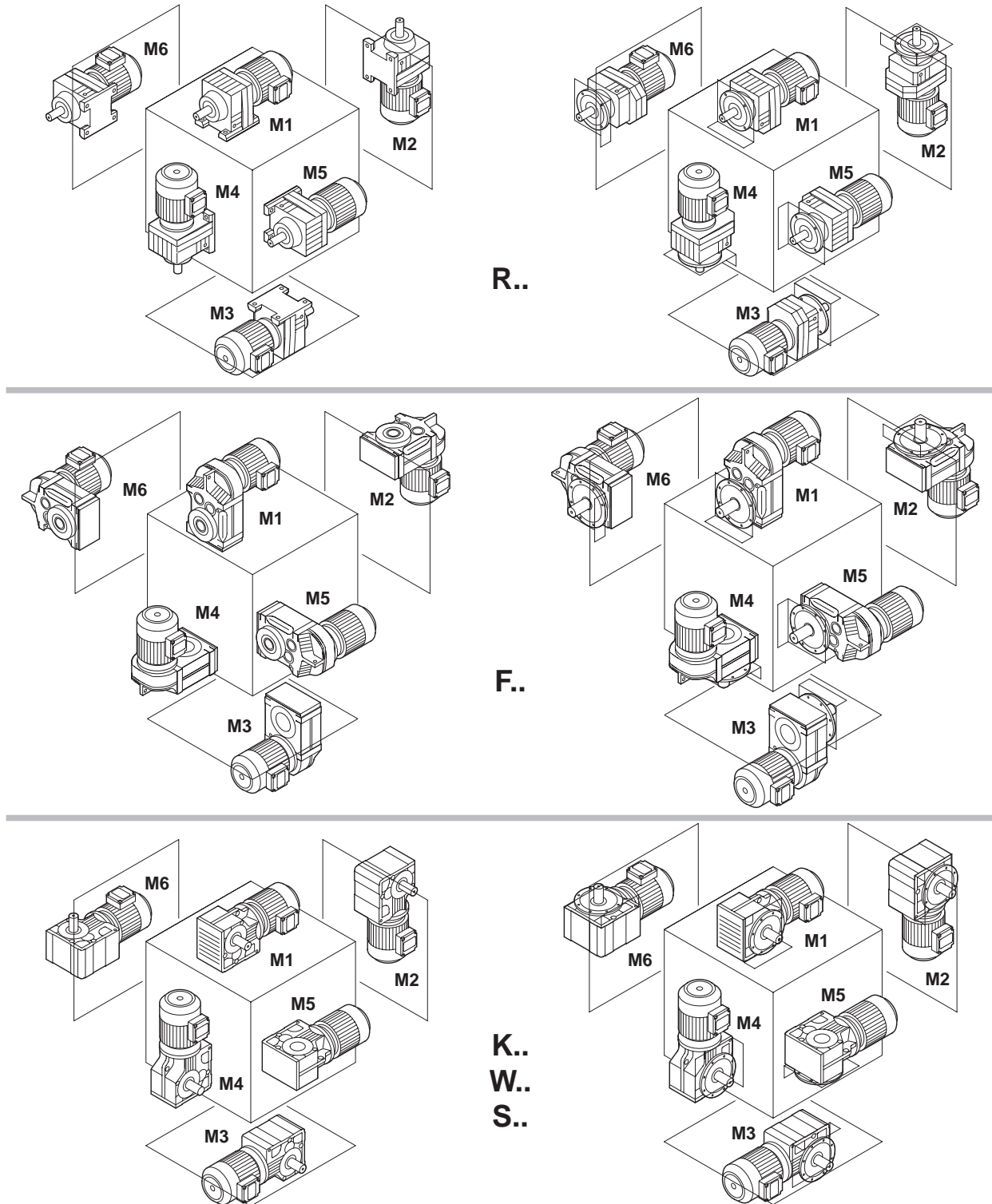

Fig. 13: Mounting positions M1 ... M6

03203AXX

**Comparison
old/new**

The following table indicates in which way the old SEW mounting position designations are integrated into the new system:

	M1	M2	M3	M4	M5	M6
R, RX	B3	V6	B8	V5	B6	B7
R..F	B35	V36	B85	V15	B65	B75
RF, RXF	B5	V3	B5II	V1	B5I	B5III
F FA..B FH..B FV..B	B6	V6	B6II	V5	B3 B8	B3I B8I
FF	B5	V3	B5II	V1	B5I	B5III
FA FHF FVF FH FAZ FV FHZ FAF FVZ	H1	H6	H2	H5	H4	H3
K KA..B KH..B KV..B	B3 B6I	B6 B8I	B8	B3I B6II	V5 V5I	V6 V6I
K/KH 166/167 186/187	B3 B5/I			B3I B5/II	V1/	V1/I
KF	B5I B3/B5I	B5 B65	B5III B8/B5III	B5II B6/B5II	V1 V15	V1I V6/V1I
KA KHF KVF KH KAZ KV KHZ KAF KVZ	H1	H4	H2	H3	H5	H6
S	B3 B6I B8II (S37)	B6 B8I	B8 B3II	B3I B6II	V5 V5I	V6 V6I V5II (S37)
SF	B5I	B5	B5III	B5II	V1	V1I
SA SH SAF SHF SAZ SHZ	H1	H4	H2	H3	H5	H6

04464AXX



Example

A KA77B helical-bevel gear unit with the old mounting position B3I or B6II, is now referred to with mounting position designation M4.

8.2 Legend for mounting position pages

Used symbols

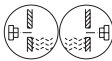
The following table contains all symbols used in the mounting position pages as well as their meaning:

Symbol	Meaning
	Breather valve
	Oil level check plug
	Oil drain plug

Churning losses



There is a possibility of increased churning losses with some mounting positions. Please contact SEW when dealing with the following combinations:

Mounting position	Gear unit type	Gear unit size	Input speed [1/min]
M2, M4	R	97 ... 107	> 2500
		> 107	> 1500
M2, M3, M4, M5, M6	F	97 ... 107	> 2500
		> 107	> 1500
	K	77 ... 107	> 2500
		> 107	> 1500
S	77 ... 97	> 2500	

8.3 Mounting positions, helical gear units

R17-R167

04 040 100

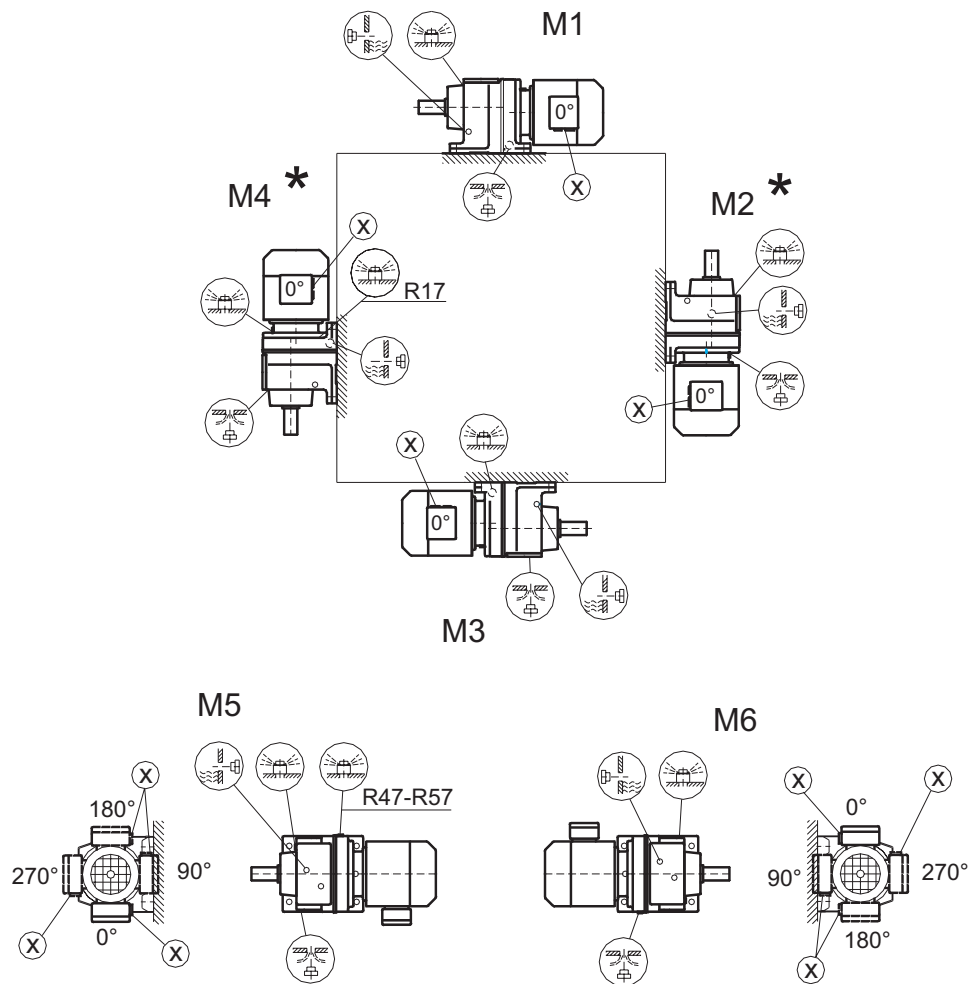
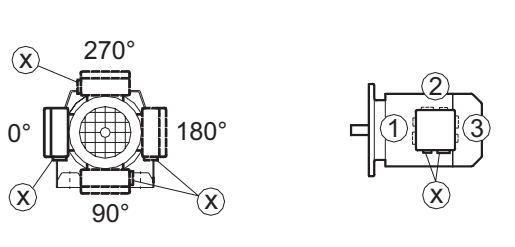

- R17, R27 M1, M3, M5, M6
- R47, R57 M5
- R17, R27

* → page 36

RF17-RF167

04 041 100

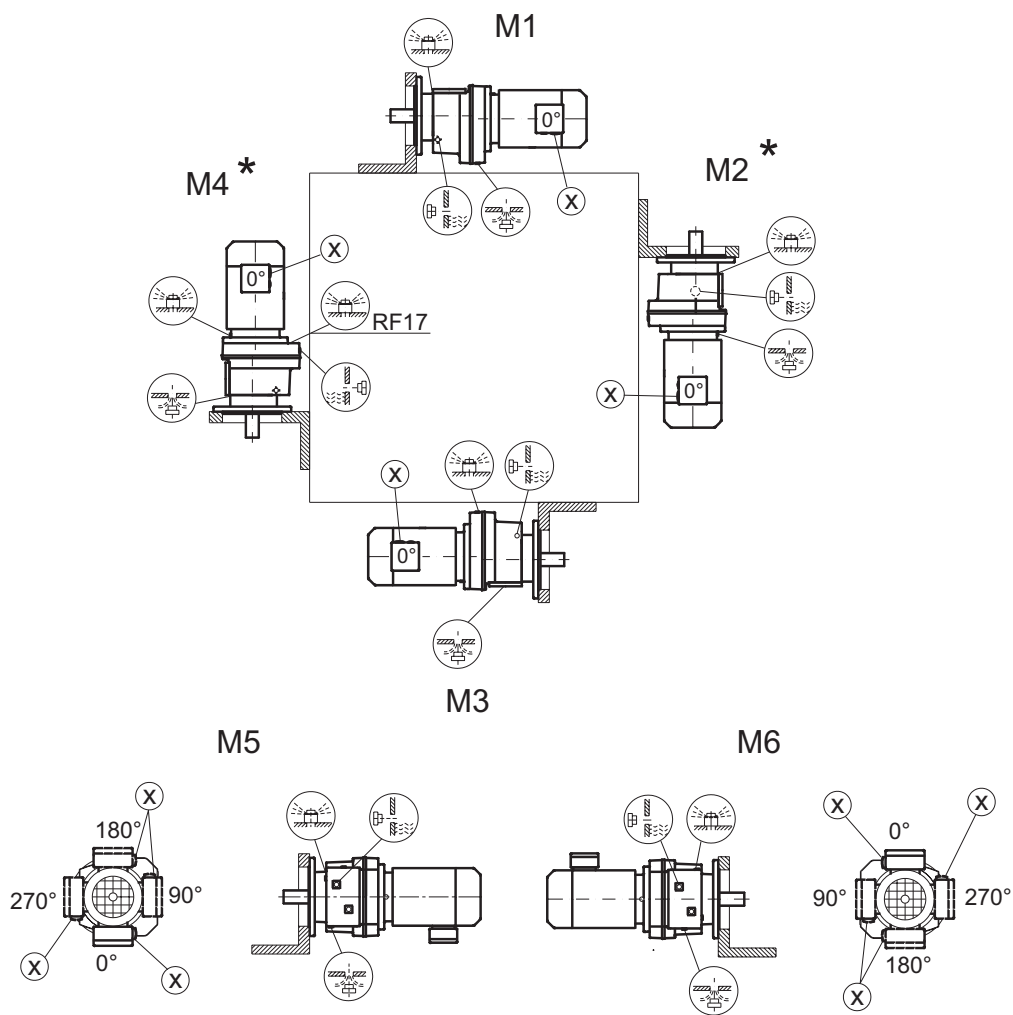
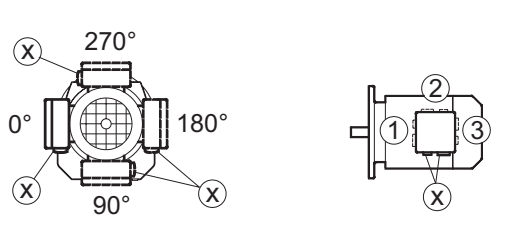





- RF17, RF27 M1, M3, M5, M6
- RF47, RF57 M5
- RF17, RF27

* → page 36

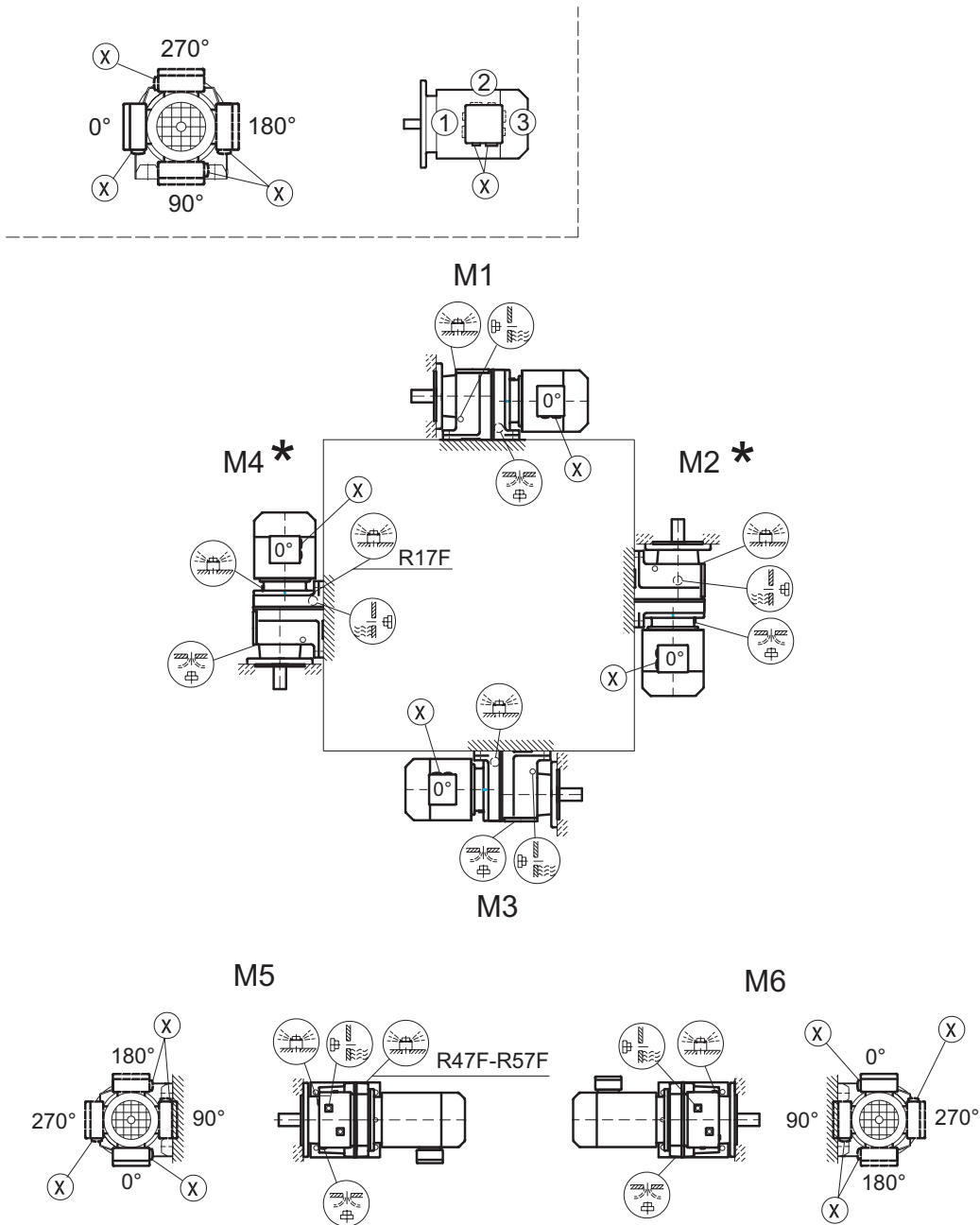
R17F-R87F

04 042 100



- R17F, R27F  M1, M3, M5, M6
- R47F, R57F  M5
- R17F, R27F  

* → page 36

Caution: Note the  notes in the "Geared Motors" catalog, section "Project Planning Gear Units/Overhung and axial loads."

RX57-RX107

04 043 100

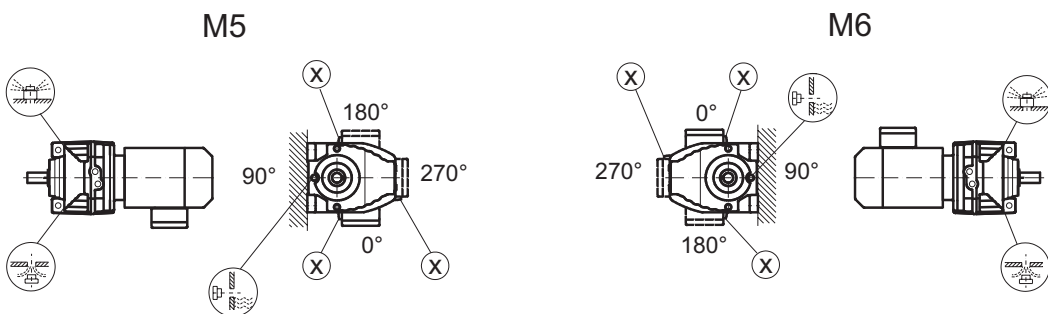
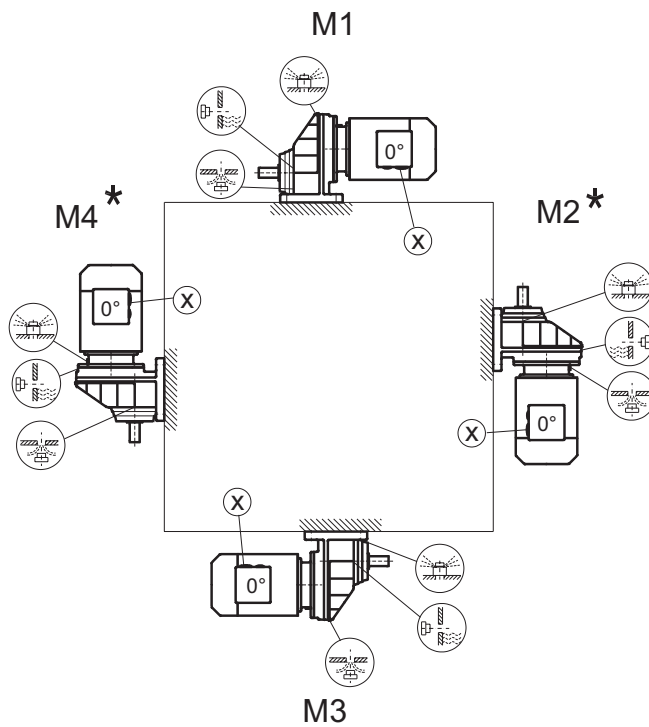
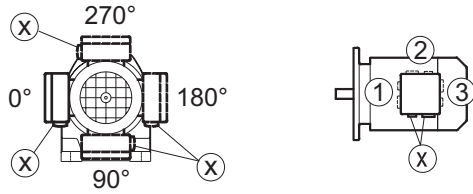

* → page 36

RXF57-RXF107

04 044 100

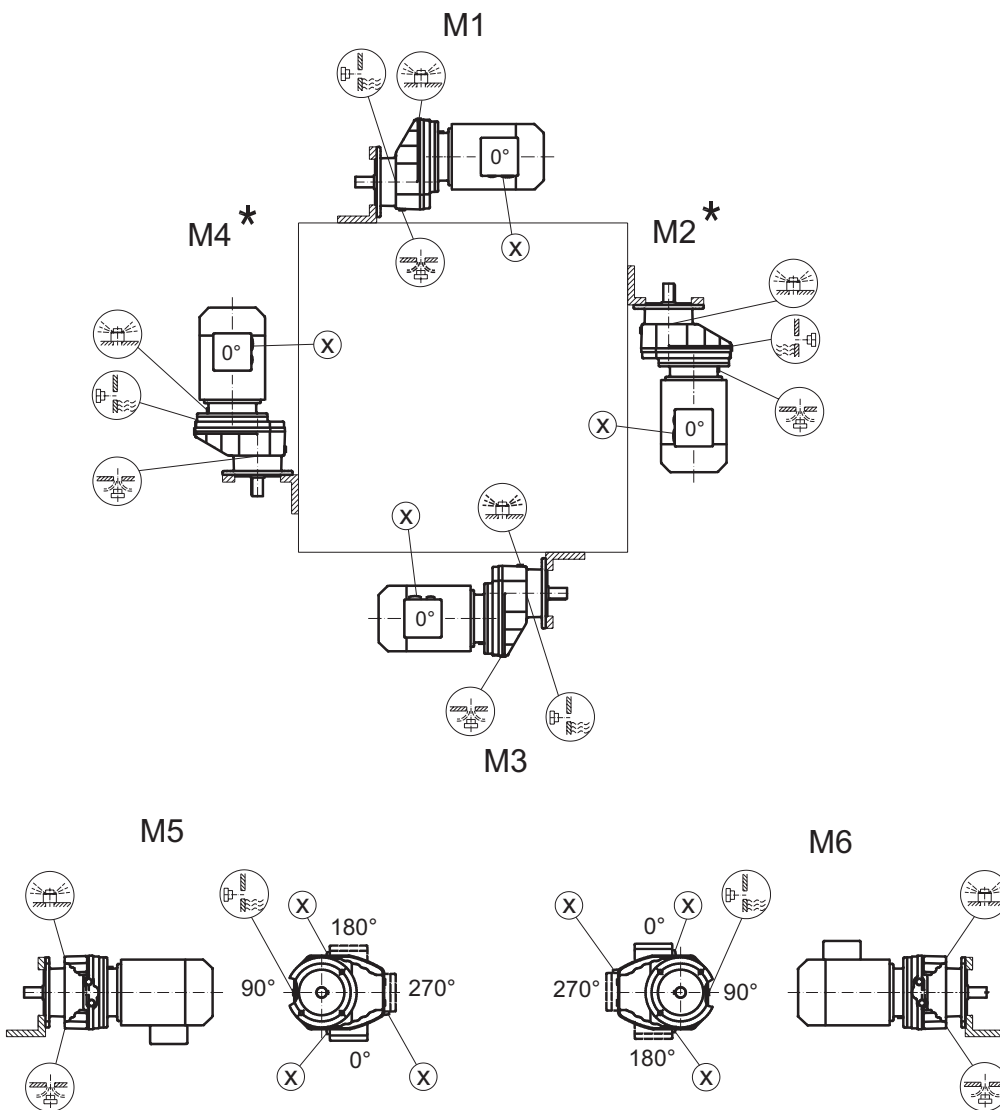
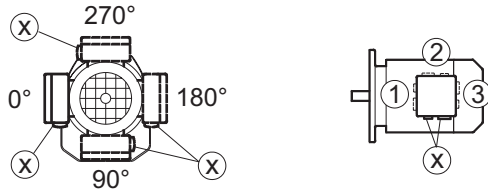





* → page 36

8.4 Mounting positions, parallel shaft helical gear units

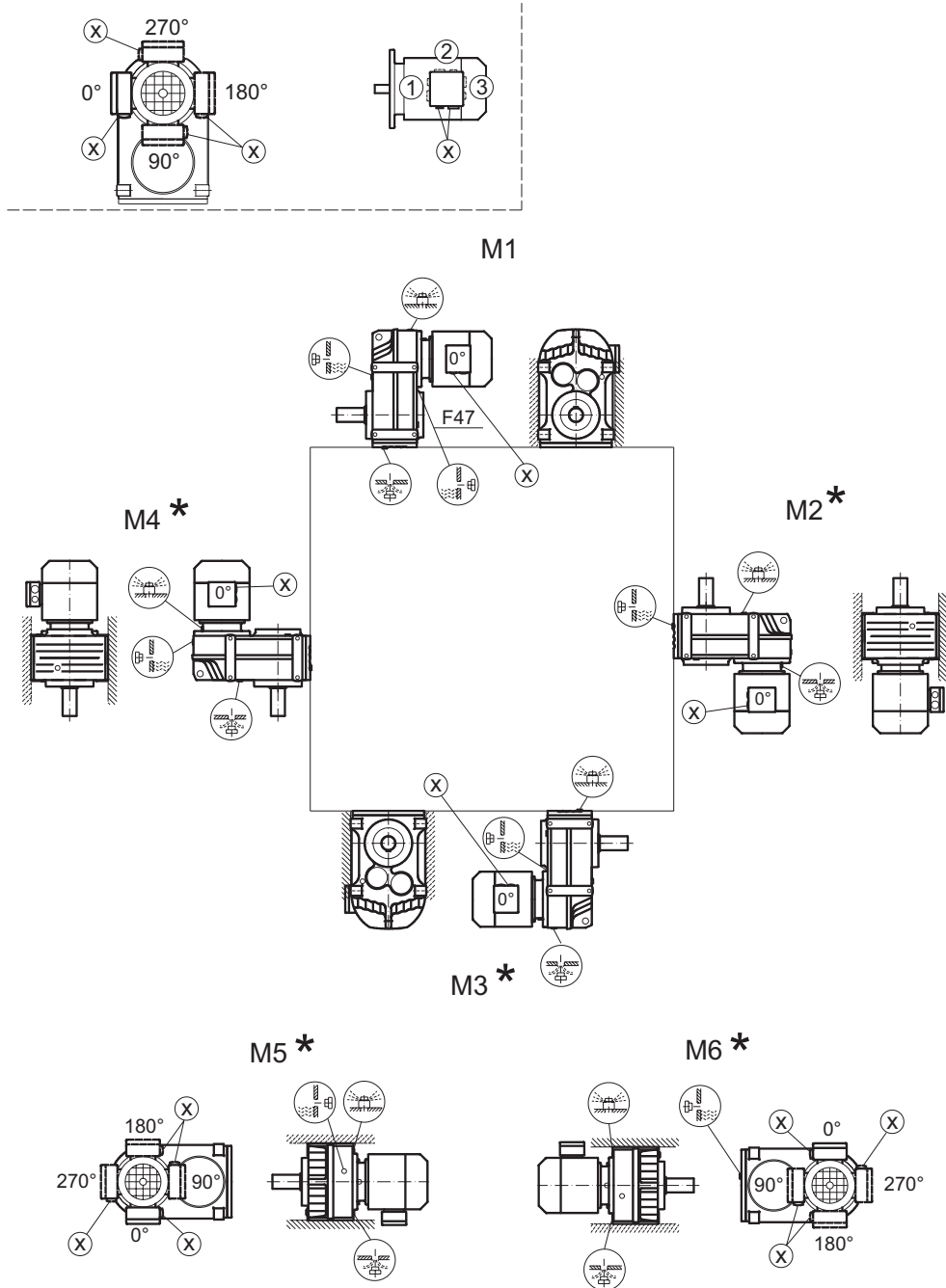
F/FA..B/FH27B-157B, FV27B-107B

42 042 100



- F..27  M1, M3, M5, M6
- F..27  M1 - M6
- F..27  M1, M3, M5, M6

* → page 36

FF/FAF/FHF/FAZ/FHZ27-157, FVF/FVZ27-107

42 043 100

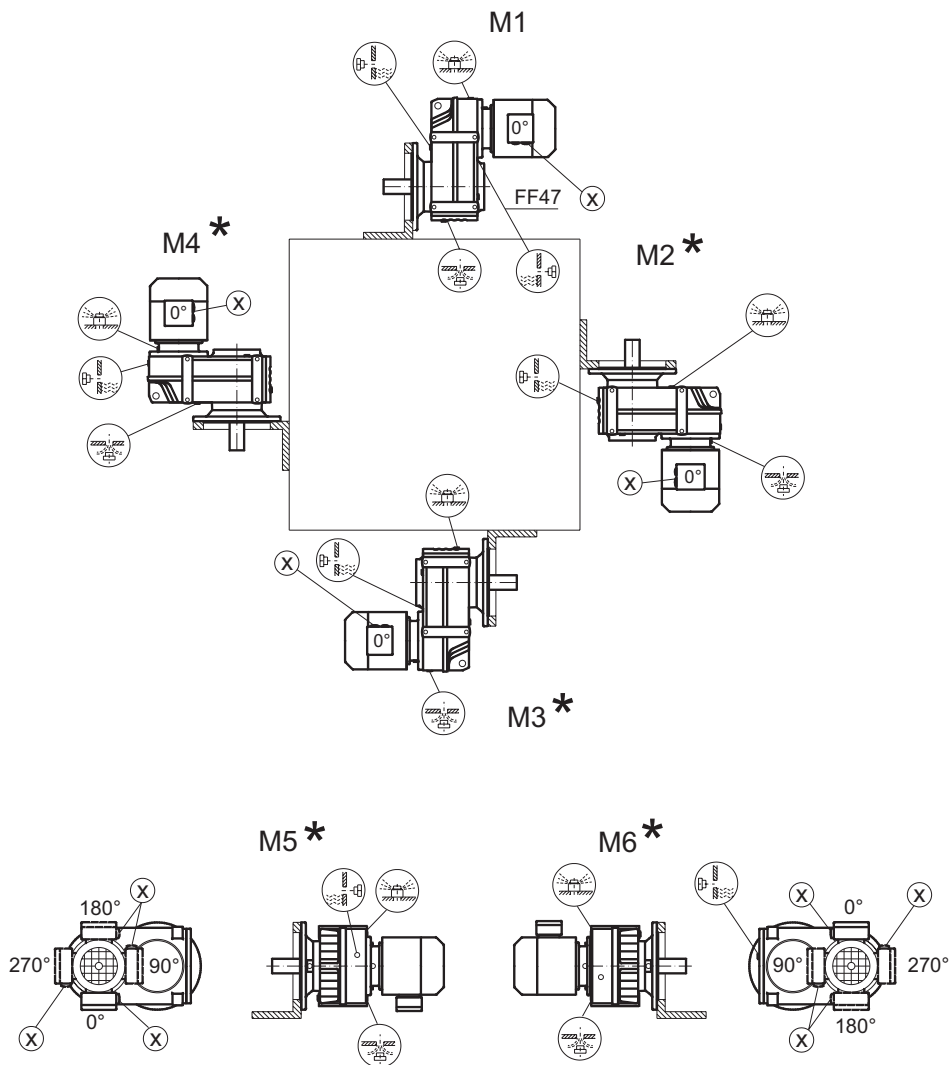
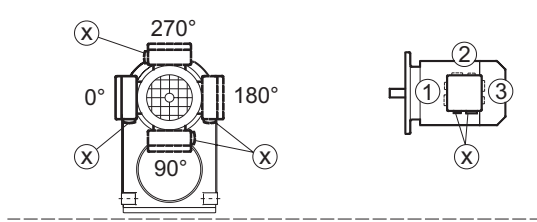

- F..27 M1, M3, M5, M6
- F..27 M1 - M6
- F..27 M1, M3, M5, M6

* → page 36

FA/FH27-157, FV27-107

42 044 100

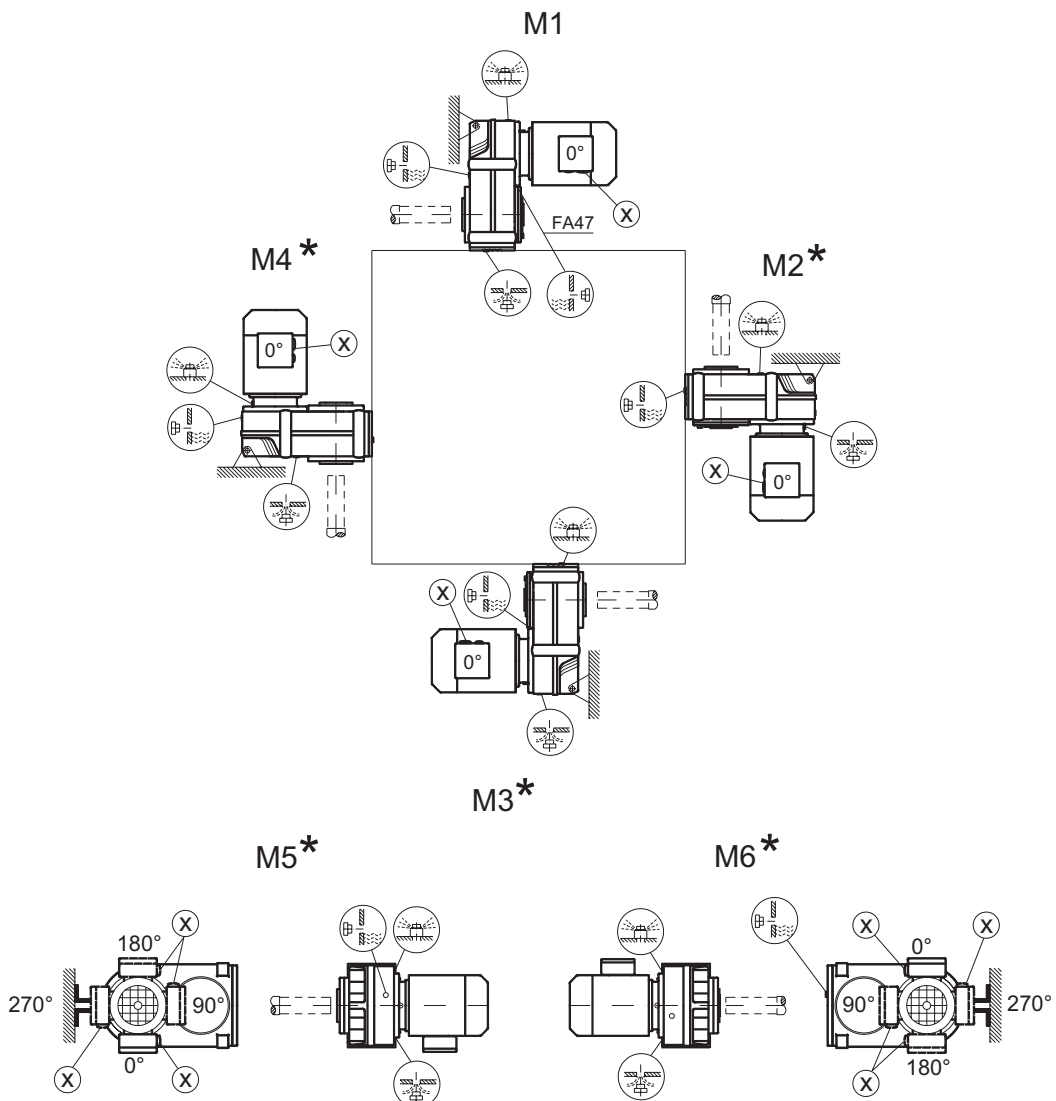
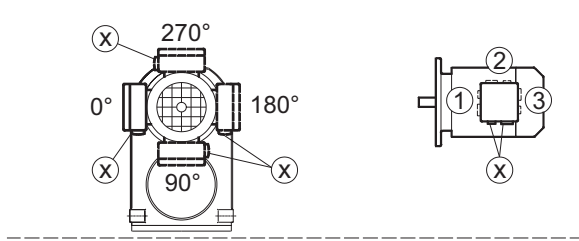

F..27  M1, M3, M5, M6

F..27  M1 - M6

F..27  M1, M3, M5, M6

* → page 36

8.5 Mounting positions, helical-bevel gear units

K/KA..B/KH37B-157B, KV37B-107B

34 025 100

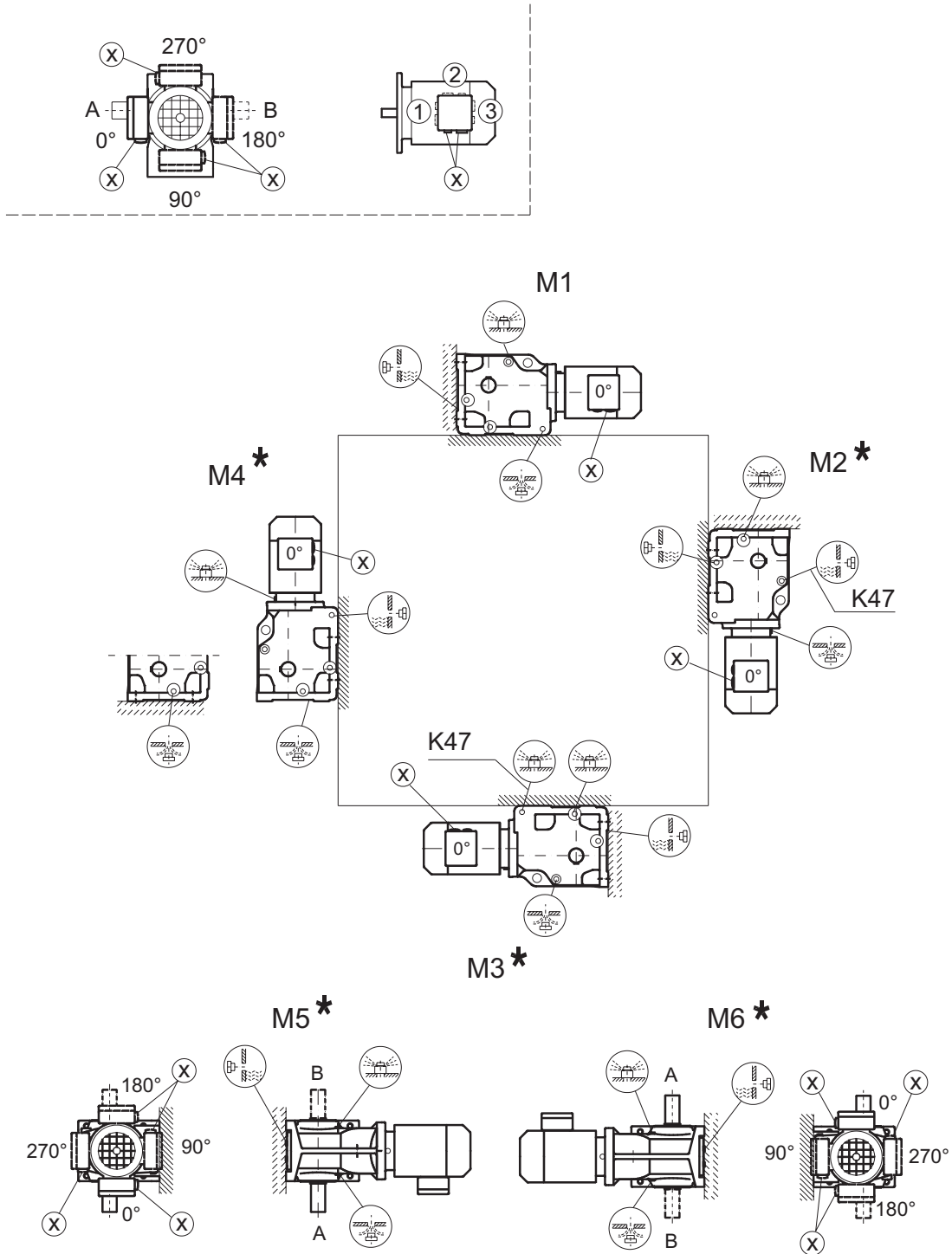

* → page 36

Caution: Note the ⓘ notes in the "Geared Motors" catalog, section "Project Planning Gear Units/Overhung and axial loads."

K167-187, KH167B-187B

34 026 100

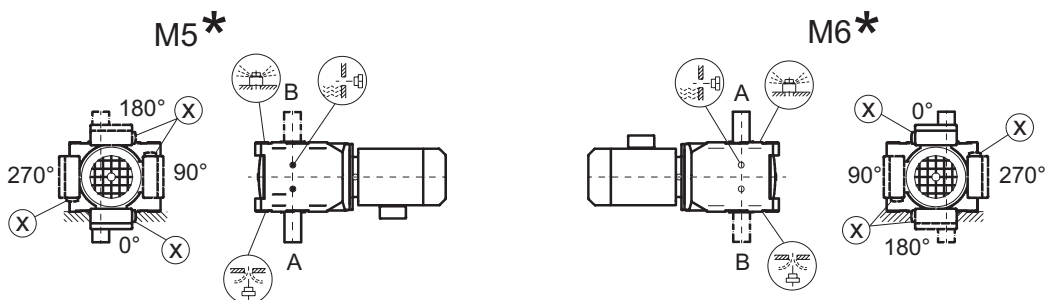
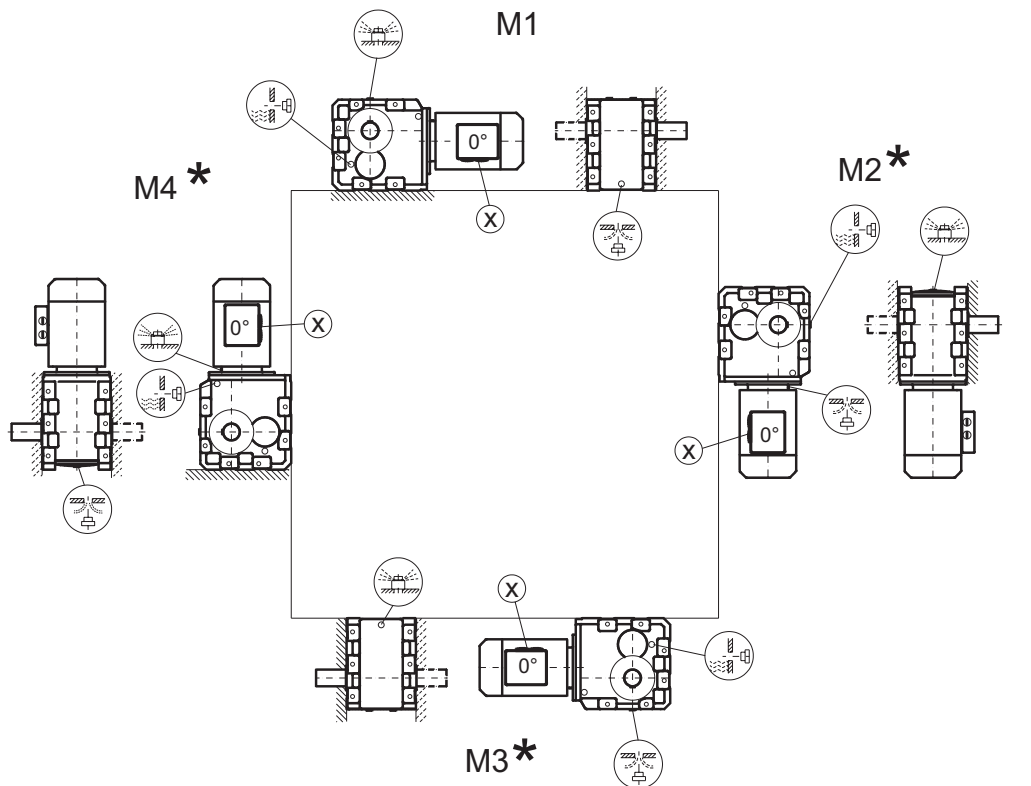
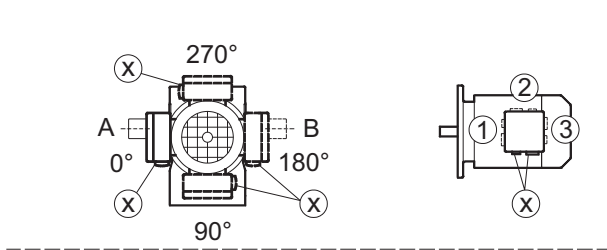

* → page 36

Caution: Note the ⓘ notes in the "Geared Motors" catalog, section "Project Planning Gear Units/Overhung and axial loads."

KF/KAF/KHF/KAZ/KHZ37-157, KVF/KVZ37-107

34 027 100

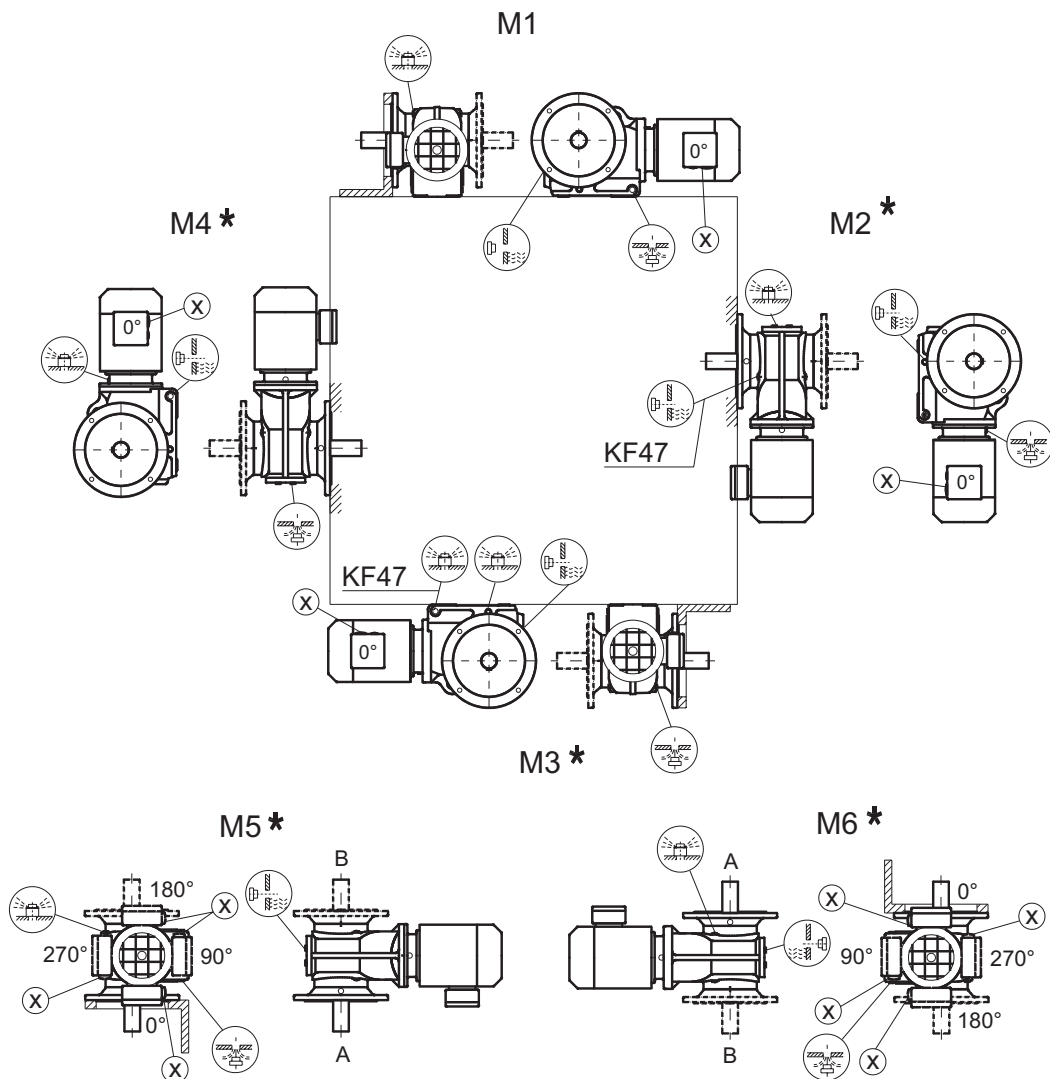
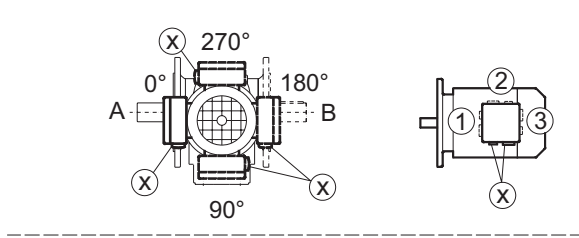

* → page 36

KA/KH37-157, KV37-107

39 025 100

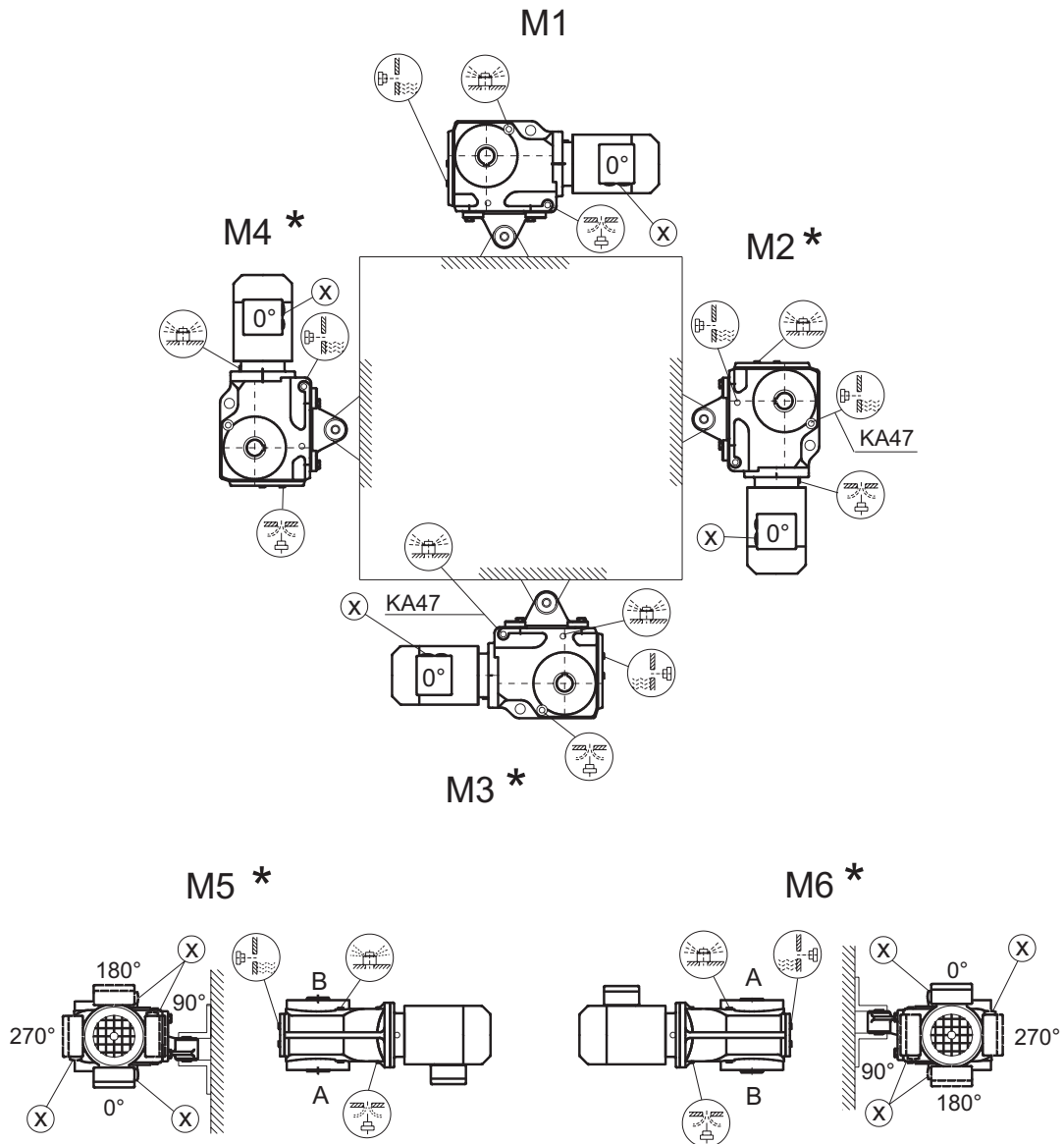
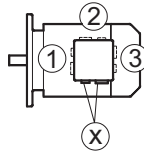
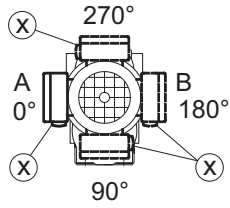

* → page 36

KH167-187

39 026 100

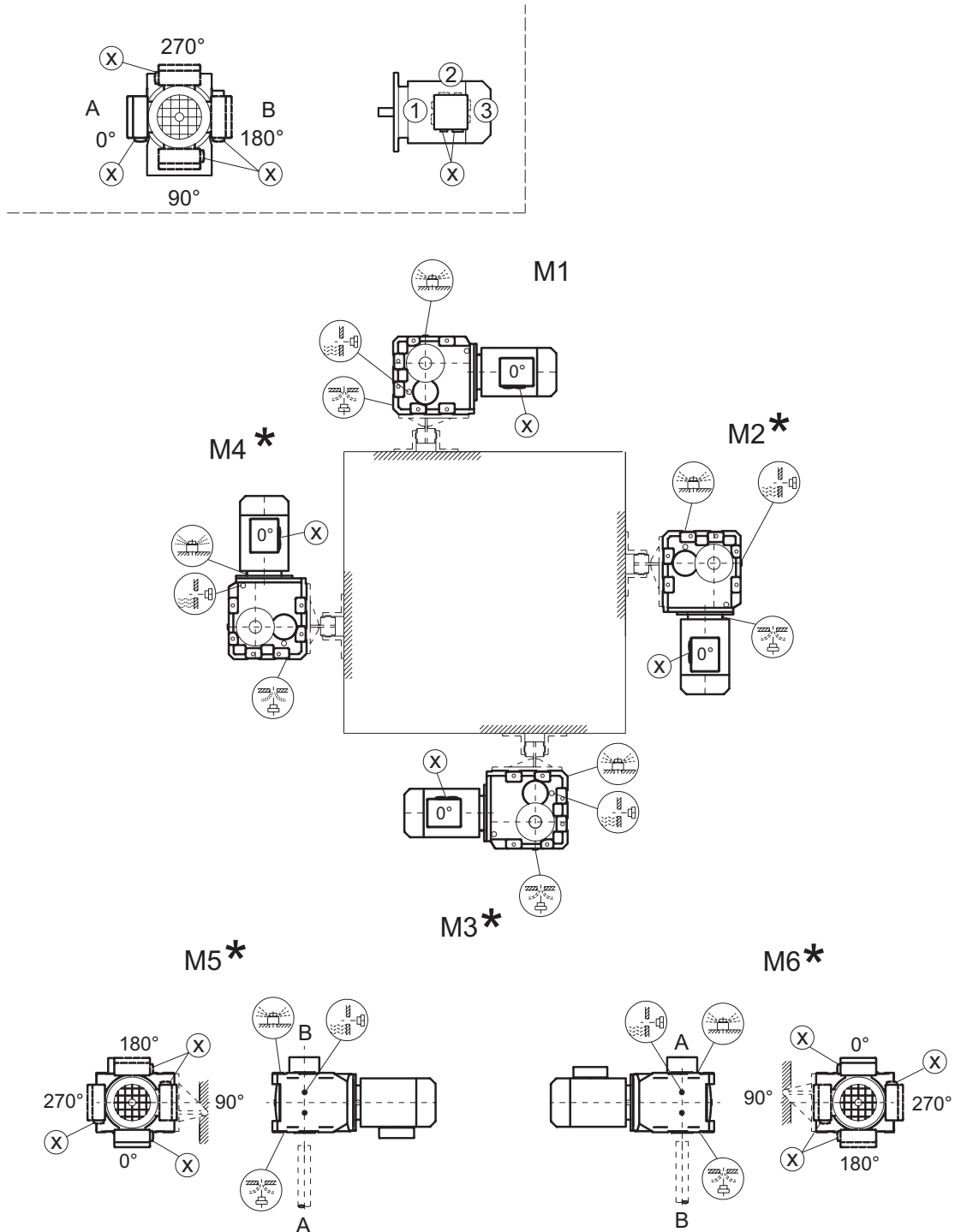

* → page 36

8.6 Mounting positions, helical-worm gear units

S37

05 025 100

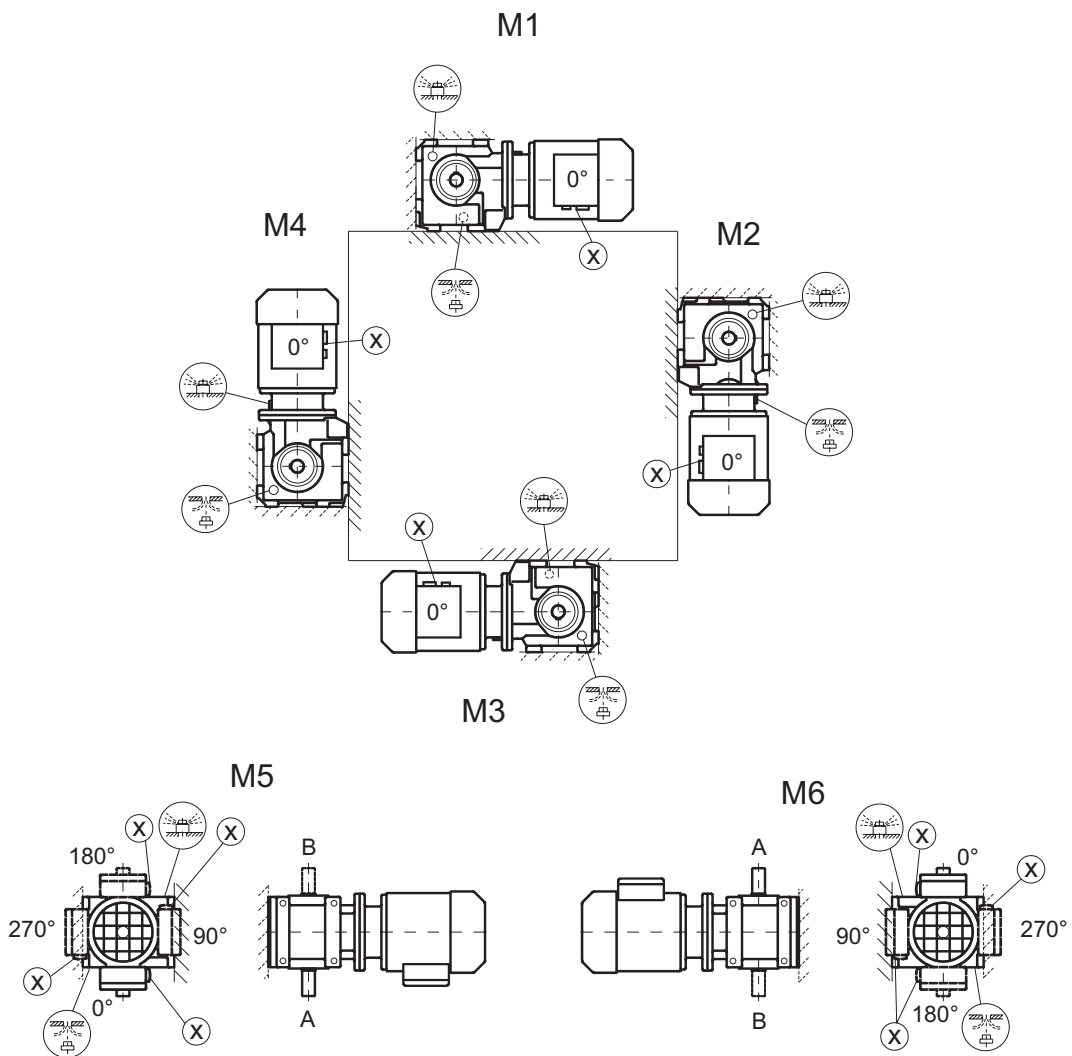
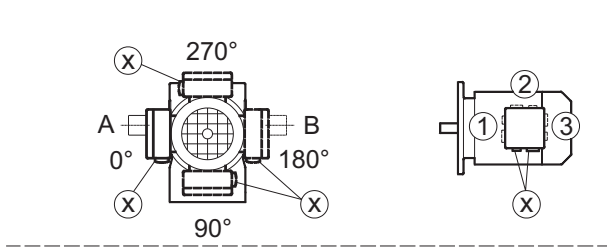

Caution: Note the ⓘ notes in the "Geared Motors" catalog, section "Project Planning Gear Units/Overhung and axial loads."

S47-S97

05 026 100

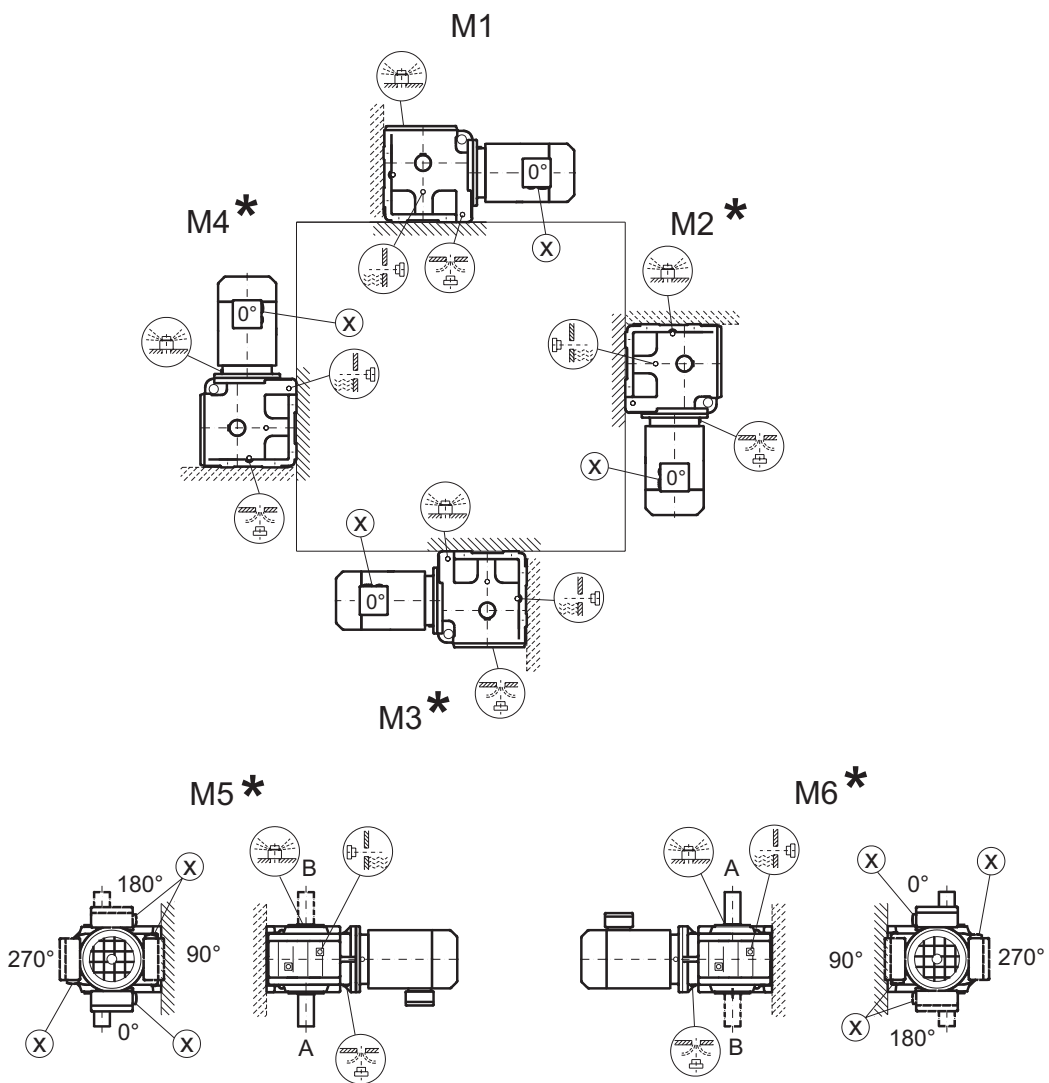
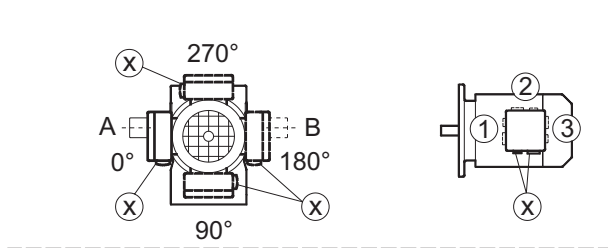

* → page 36

Caution: Note the notes in the "Geared Motors" catalog, section "Project Planning Gear Units/Overhung and axial loads."

SF/SAF/SHF37

05 027 100

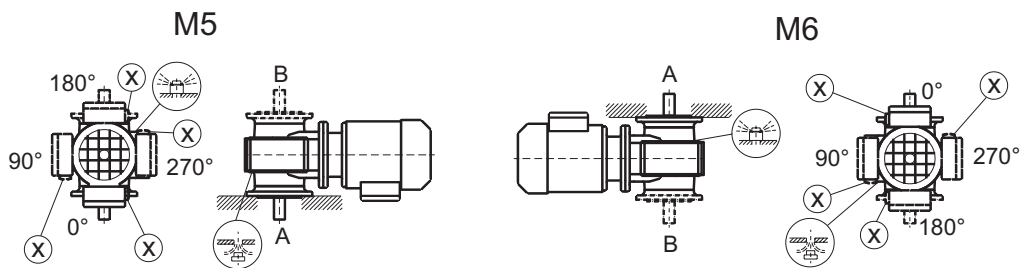
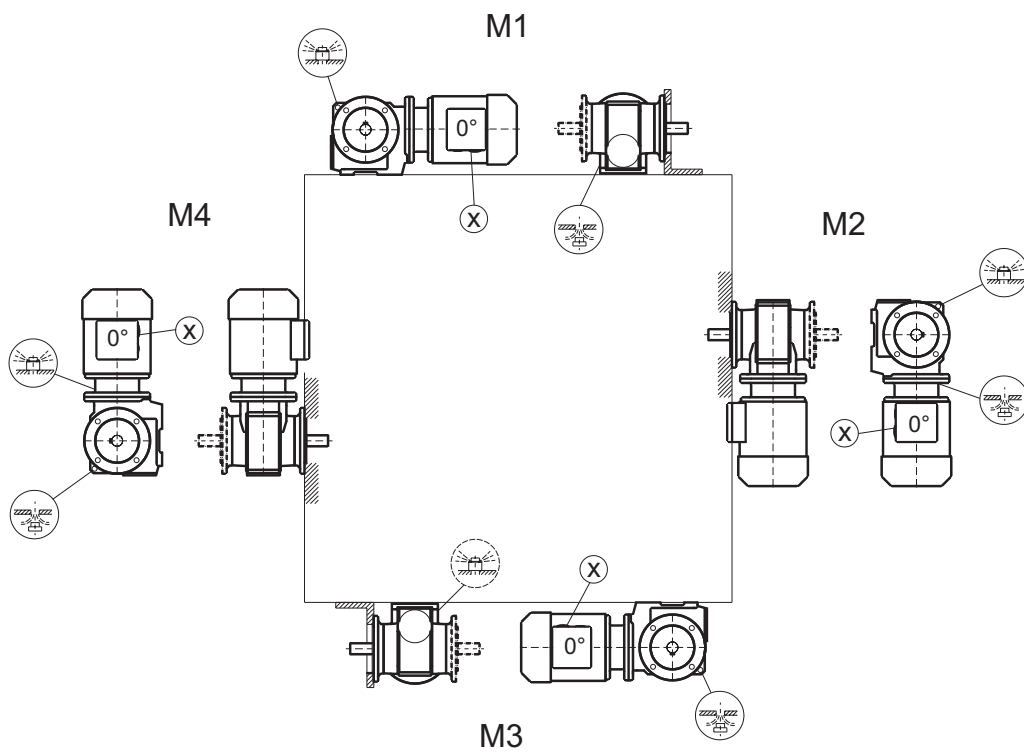

SF/SAF/SHF/SAZ/SHZ47-97

05 028 100

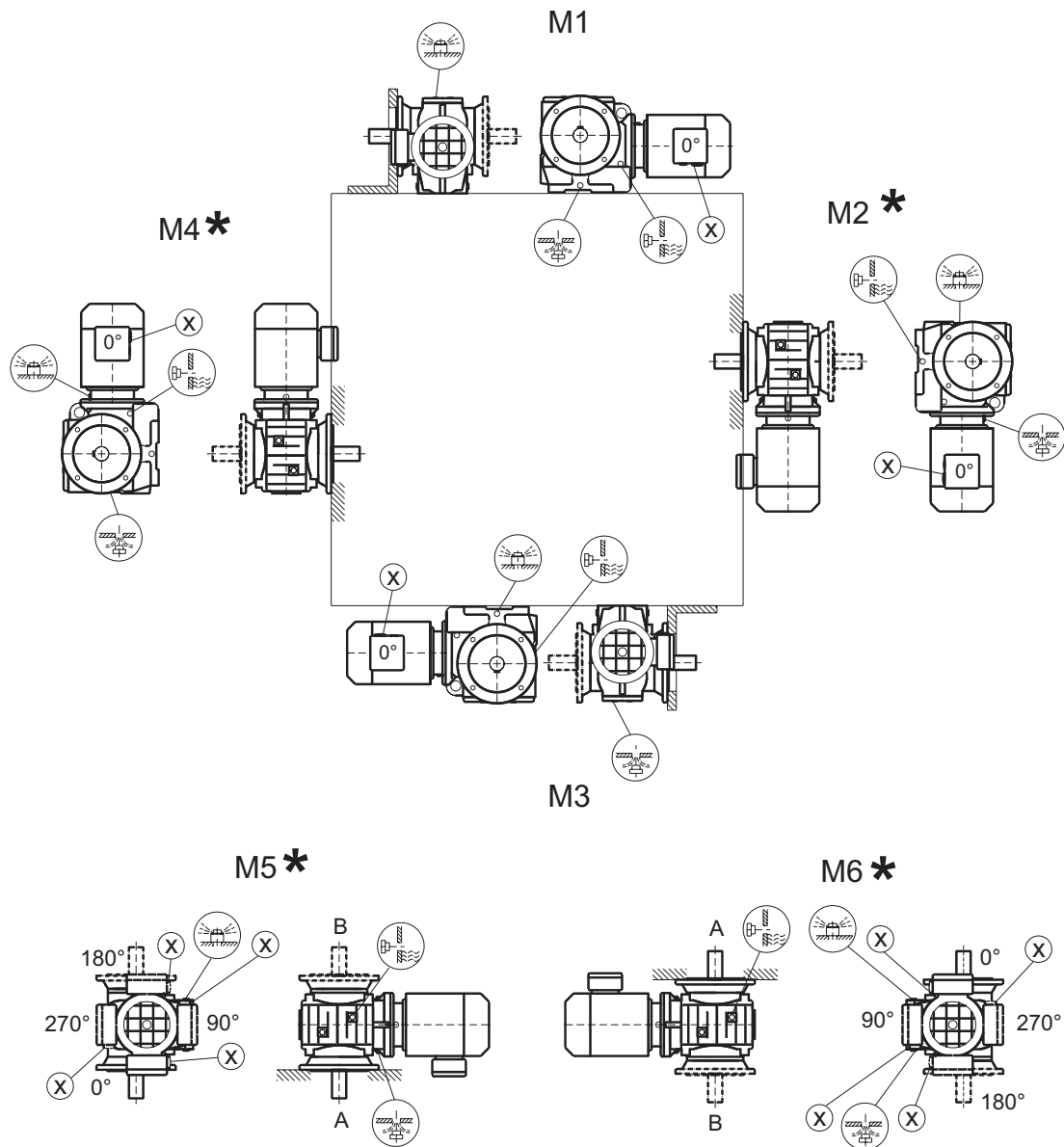
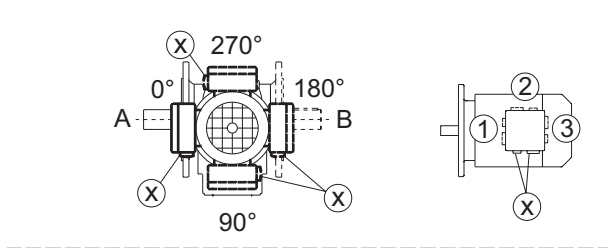

* → page 36

SA/SH37

28 020 100

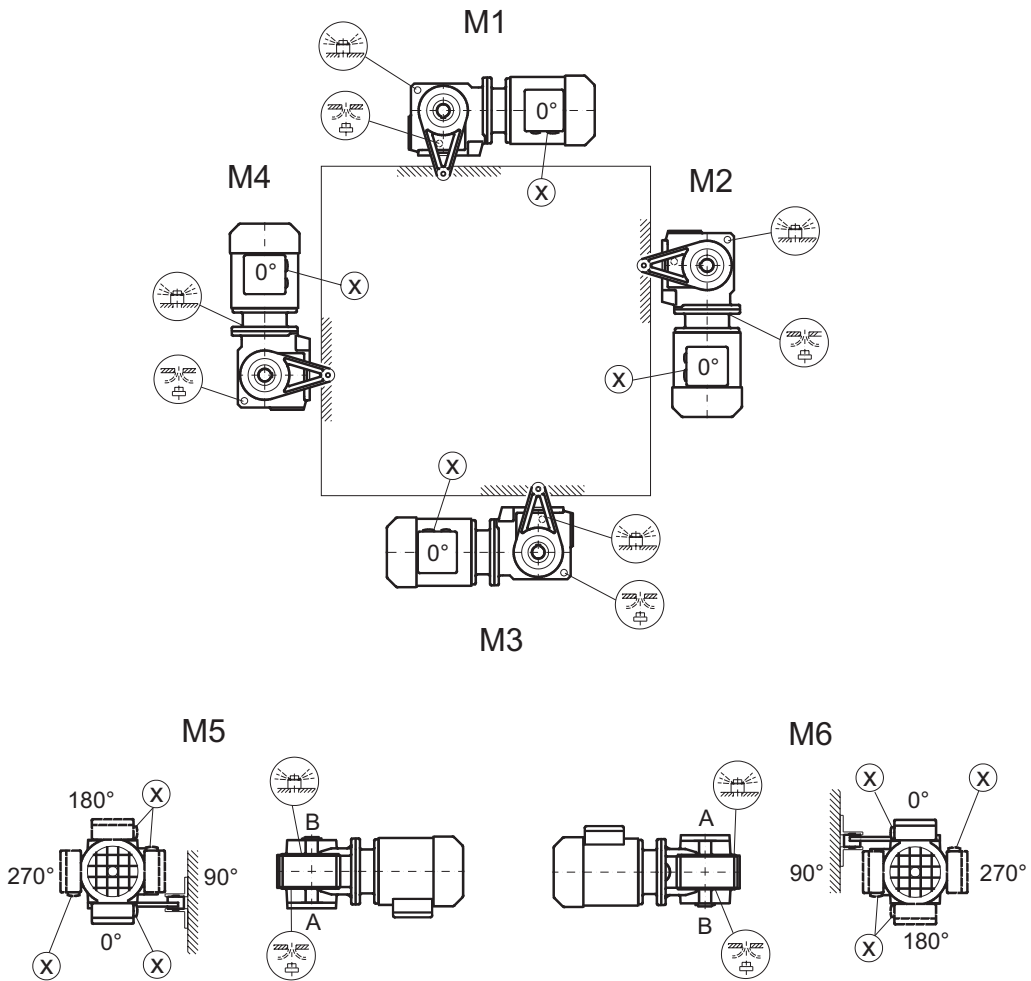
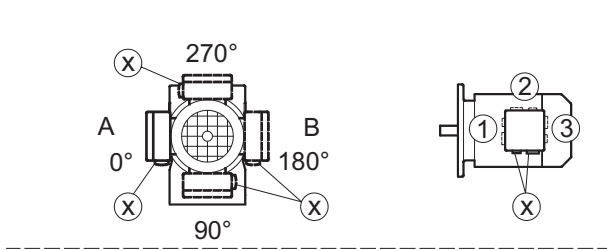

SA/SH47-97

28 021 100

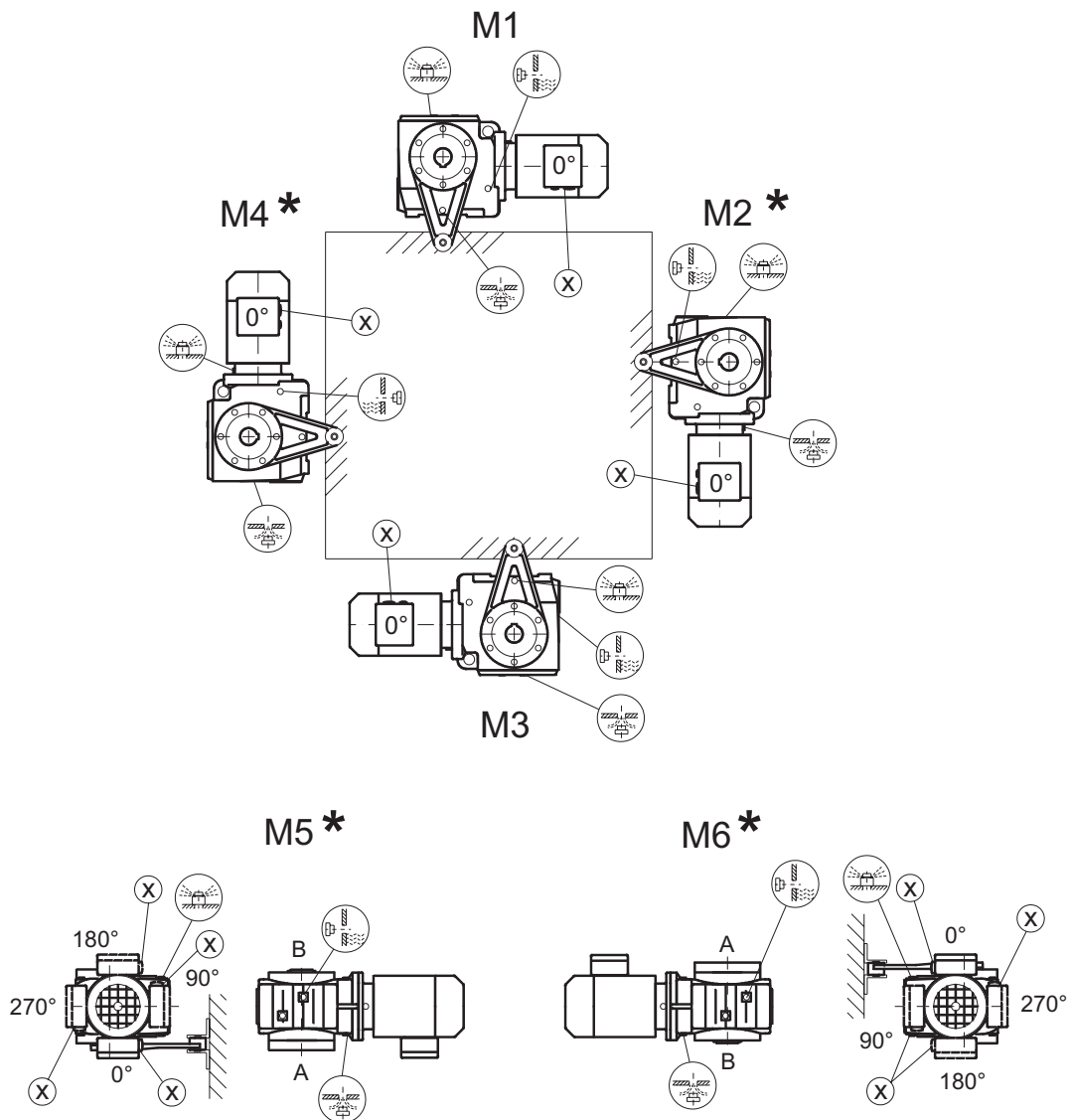
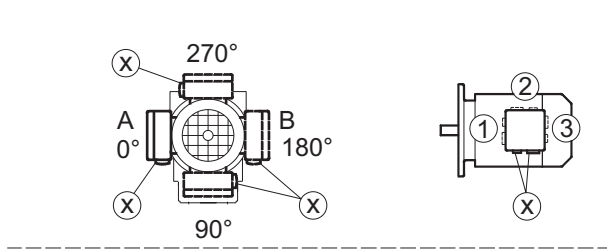

* → page 36



9 Lubricants

General



SEW supplies the drives filled with a lubricant appropriate for the specific gear unit and mounting position. The decisive factor is the indicated mounting position (M1...M6, → section "Mounting positions and important order information") when ordering the drive. The lubricant fill amounts for subsequent changes in the mounting position will have to be adjusted for the specific mounting position (→ Lubricant fill quantities).

Lubricant table

The lubricant table for SEW drives on the following page is a list of all approved lubricants for SEW drives. Please note the following legend for the lubricant table.

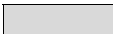
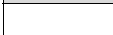

Legend for lubricant table

Abbreviations, meaning of shading and notes:

CLP	= Mineral oil
CLP PG	= Polyglykol (W gear unit, meeting USDA-H1 standard)
CLP HC	= Synthetic hydrocarbons
E	= Diester oil (water pollution class WGK 1)
HCE	= Synthetic hydrocarbons + diester oil (USDA - H1 approval)
HLP	= Hydraulic oil
	= Synthetic lubricant (= anti-friction bearing grease on synthetic base)
	= Mineral lubricant (= anti-friction bearing grease on mineral base)
1)	Helical-worm gear unit with PG oil: Please consult SEW
2)	Special lubricant for Spiroplan® gear units only
3)	Recommendation: Select SEW $f_B \geq 1.2$
4)	Note critical starting performance at low temperatures!
5)	Low-viscosity grease
6)	Ambient temperature
	Lubricant for the food industry
	Biological oil (lubricant for agricultural, forestry and water industry)

Anti-friction bearing greases

The anti-friction bearings in SEW gear units and motors will be filled with the following greases at the factory. SEW recommends to change the grease when replacing the oil in anti-friction bearings with grease filling.

	Ambient temperature	Manufacturer	Type
Gear unit anti-friction bearing	-30°C ... +60°C	Mobil	Mobilux EP 2
	-40°C ... +80°C	Mobil	Mobiltemp SHC 100
Motor anti-friction bearing	-25°C ... +80°C	Esso	Unirex N3
	-25°C ... +60°C	Shell	Alvania R3
	+80°C ... +100°C	Klüber	Barrierta L55/2
	-45°C ... -25°C	Shell	Aero Shell Grease 16
Special greases for gear unit anti-friction bearings:			
	-30°C ... +40°C	Aral	Aral Eural Grease EP 2
	-20°C ... +40°C	Aral Klüber	Aral Aralub BAB EP 2 Klüberbio M32-82



You need the following grease amounts:

- For fast-running bearings (motor and gear unit input side): Fill one third of the hollow spaces between the actual roller bodies with grease.
- For slow-running bearings (in gear unit and gear unit output side): Fill two thirds of the spaces between the actual roller bodies with grease.



Table of lubricants

01 805 692

	6)	DIN (ISO)	ISO, NLGI	Mobil®	Shell	KLÜBER LUBRICANTEN	ARAL	BP	Tribol	TEJACO	Optimal	FUCHS
R...	Standard -10 +40	CLP (CC)	VG 220	Mobilgear 630	Shell Omala 220	Klüberoil GEM 1-220	Aral Degol BG 220	BP Energol GR-XP 220	Tribol 1100/220	Meropa 220	Optigear BM 220	Renolin CLP 220
K... (HK...)	-25 +80	CLP PG	VG 220	Mobil Glygolye 30	Shell Tivela WB	Klüberoil GEM 1-220	Aral Degol GS 220	BP Energol SG-XP 220	Tribol 800/220	Synlube CLP 220	Optiflex A 220	
F...	-40 +40	CLP HC	VG 220	Mobilgear SHC 630	Shell Omala 220 HD	Klüberoil GEM 1-220	Aral Degol PAS 220		Tribol 1510/220	Pinnacle EP 220	Optigear Synthetic A 220	Renolin Unisyn CLP 220
	-40 +40		VG 150	Mobil SHC 629		Klüberoil GEM 4-150				Pinnacle EP 150		
	-20 +25	CLP (CC)	VG 150	Mobilgear 629	Shell Omala 100	Klüberoil GEM 1-150	Aral Degol BG 100	BP Energol GR-XP 100	Tribol 1100/100	Meropa 150	Optigear BM 100	Renolin CLP 150
	-30 +10	HLP (HM)	VG 68-46	Mobil D.T.E. 15M	Shell Tellus T 32	Klüberoil GEM 1-68	Aral Degol BG 46		Tribol 1100/68	Rando EP Ashless 46	Optigear 32	Renolin B 46 HVI
	-40 +10	CLP HC	VG 32	Mobil SHC 624		Klüber-Summit HySyn FG-32				Cetus PAO 46		
	-40 +20	HLP (HM)	VG 22	Mobil D.T.E. 11M	Shell Tellus T 15	Isoteflex MT 30 ROT		BP Energol HLP-HM 10		Rando HDZ 15		
	Standard 0 +40	CLP (CC)	VG 680	Mobilgear 636	Shell Omala 680	Klüberoil GEM 1-680	Aral Degol BG 680	BP Energol GR-XP 680	Tribol 1100/680	Meropa 680	Optigear BM 680	Renolin CLP 680
S... (HS...)	-20 +60	CLP PG	VG 680 ¹⁾	Mobil Glygolye HE 680		Klüberoil GEM 6-680		BP Energol SG-XP 680	Tribol 800/680	Synlube CLP 680		
	-30 +80	CLP HC	VG 460	Mobil SHC 634	Shell Omala 460 HD	Klüberoil GEM 4-460				Pinnacle EP 460		
	-40 +10		VG 150	Mobil SHC 629		Klüberoil GEM 4-150				Pinnacle EP 150		
	-20 +10	CLP (CC)	VG 150	Mobil D.T.E. 18M	Shell Omala 100	Klüberoil GEM 1-150	Aral Degol BG 100	BP Energol GR-XP 100	Tribol 1100/100	Meropa 100	Optigear BM 100	Renolin CLP 150
	-25 +20	HLP (HM)	VG 100	Mobil Glygolye 30		Klüberoil GEM 6-220			Tribol 800/220	Synlube CLP 220	Optiflex A 220	
	-40 0	CLP PG	VG 220 ¹⁾			Klüber-Summit HySyn FG-32				Cetus PAO 46		
	-40 0	CLP HC	VG 32	Mobil SHC 624		Klüber-Summit HySyn FG-32						
R..., K... (HK...), F..., S... (HS...)	-30 +40	HCE	VG 460		Shell Cassida Fluid GL 460	Klüberoil 4UH1-460	Aral Eural Gear 460				Optileb GT 460	
	-20 +40	E	VG 460			Klüberoil CA2-460	Aral Degol BAB 460				Optisynth BS 460	
W... (HW...)	Standard -20 +40	SEW PG	VG 460 ²⁾			Klüber SEW HT-460-5						
	-40 +10	API GL5	SAE 75W90 (-VG 100)	Mobilube SHC 75 W90-LS								
	-20 +40	CLP PG	VG 460 ³⁾			Klüberoil UH1 6-460						
R32 R302	-25 +60	DIN 51 818 ⁵⁾	00	Glygolye Grease 00	Shell Tivela Compound A	Klüberoil GE 46-1200				Multifak 6833 EP 00		Renolin SF 7 - 041
	Standard -15 +40		000 - 0	Mobilux EP 004	Shell Alvania GL 00	Klüberoil GE 46-1200	Aralub MFL 00	BP Energol LS-EP 00		Multifak EP 000	Longtime PD 00	Renolin SF 7 - 041

50258AXX



Lubricant fill quantities

The indicated fill quantities are **recommended values**. The specific values vary depending on number of stages and ratio. Pay close attention to the **oil level plug to serve as indicator for the correct amount of oil**.

The following tables list the recommended values for the lubricant fill quantities in reference to mounting positions M1...M6.

Helical (R-) gear units

Gear units R.., R..F	Fill quantity in liters					
	M1 ¹⁾	M2 ¹⁾	M3	M4	M5	M6
R17/R17F	0.25	0.6	0.35	0.6	0.35	0.35
R27/R27F	0.25/0.4	0.7	0.4	0.7	0.4	0.4
R37/R37F	0.3/1	0.9	1	1.1	0.8	1
R47/R47F	0.7/1.5	1.6	1.5	1.7	1.5	1.5
R57/R57F	0.8/1.7	1.9	1.7	2.1	1.7	1.7
R67/R67F	1.1/2.3	2.6/3.5	2.8	3.2	1.8	2
R77/R77F	1.2 / 3	3.8 / 4.3	3.6	4.3	2.5	3.4
R87/R87F	2.3 / 6	6.7 / 8.4	7.2	7.7	6.3	6.5
R97	4.6/9.8	11.7/14	11.7	13.4	11.3	11.7
R107	6/13.7	16.3	16.9	19.2	13.2	15.9
R137	10/25	28	29.5	31.5	25	25
R147	15.4/40	46.5	48	52	39.5	41
R167	27/70	82	78	88	66	69

Gear units RF..	Fill quantity in liters					
	M1 ¹⁾	M2 ¹⁾	M3	M4	M5	M6
RF17	0.25	0.6	0.35	0.6	0.35	0.35
RF27	0.25/0.4	0.7	0.4	0.7	0.4	0.4
RF37	0.4/1	0.9	1	1.1	0.8	1
RF47	0.7/1.5	1.6	1.5	1.7	1.5	1.5
RF/RM57	0.8/1.7	1.8	1.7	2	1.7	1.7
RF/RM67	1.2/2.5	2.7/3.6	2.7	3.1	1.9	2.1
RF/RM77	1.2 / 2.6	3.8/4.1	3.3	4.1	2.4	3
RF/RM87	2.4 / 6	6.8/7.9	7.1	7.7	6.3	6.4
RF/RM97	5.1/10.2	11.9/14	11.2	14	11.2	11.8
RF/RM107	6.3/14.9	15.9	17	19.2	13.1	15.9
RF/RM137	9.5/25	27	29	32.5	25	25
RF/RM147	16.4/42	47	48	52	42	42
RF/RM167	26/70	82	78	88	65	71

1) The larger gear unit in multi-stage gear units must be filled with the larger oil quantity.

Gear units RX..	Fill quantity in liters					
	M1	M2	M3	M4	M5	M6
RX57	0.6	0.8	1.3	1.3	0.9	0.9
RX67	0.8	0.8	1.7	1.9	1.1	1.1
RX77	1.1	1.5	2.6	2.7	1.6	1.6
RX87	1.7	2.5	4.8	4.8	2.9	2.9
RX97	2.1	3.4	7.4	7	4.8	4.8
RX107	3.9	5.6	11.6	11.9	7.7	7.7

Gear units RXF..	Fill quantity in liters					
	M1	M2	M3	M4	M5	M6
RXF57	0.5	0.8	1.1	1.1	0.7	0.7
RXF67	0.7	0.8	1.5	1.7	1	1
RXF77	0.9	1.5	2.4	2.5	1.6	1.6
RXF87	1.6	2.5	4.9	4.7	2.9	2.9
RXF97	2.1	3.6	7.1	7	4.8	4.8
RXF107	3.1	5.9	11.2	10.5	7.2	7.2



Parallel shaft heli-
cal (F-) gear units

F..., FA..B, FH..B, FV..B:

Gear units	Fill quantity in liters					
	M1	M2	M3	M4	M5	M6
F..27	0.6	0.8	0.7	0.7	0.6	0.6
F..37	1	1.2	0.7	1.2	1	1.1
F..47	1.5	1.8	1.1	1.9	1.5	1.7
F..57	2.6	3.7	2.1	3.5	2.8	2.9
F..67	2.7	3.8	1.9	3.8	2.9	3.2
F..77	5	7.3	4.3	8	6	6.3
F..87	10	13.0	7.7	13.8	10.8	11
F..97	18.5	22.5	12.6	25.2	18.5	20
F..107	24.5	32	19.5	37.5	27	27
F..127	40.5	55	34	61	46.5	47
F..157	69	104	63	105	86	78

FF...:

Gear units	Fill quantity in liters					
	M1	M2	M3	M4	M5	M6
FF27	0.6	0.8	0.7	0.7	0.6	0.6
FF37	1	1.2	0.7	1.3	1	1.1
FF47	1.6	1.9	1.1	1.9	1.5	1.7
FF57	2.8	3.8	2.1	3.7	2.9	3
FF67	2.7	3.8	1.9	3.8	2.9	3.2
FF77	5.1	7.3	4.3	8.1	6	6.3
FF87	10.3	13.2	7.8	14.1	11	11.2
FF97	19	22.5	12.6	25.5	18.9	20.5
FF107	25.5	32	19.5	38.5	27.5	28
FF127	41.5	56	34	63	46.5	49
FF157	72	105	64	106	87	79

FA..., FH..., FV..., FAF..., FHF..., FVF..., FAZ..., FHZ..., FVZ...:

Gear units	Fill quantity in liters					
	M1	M2	M3	M4	M5	M6
F..27	0.6	0.8	0.7	0.7	0.6	0.6
F..37	1	1.2	0.7	1.2	1	1.1
F..47	1.5	1.8	1.1	1.9	1.5	1.7
F..57	2.7	3.8	2.1	3.6	2.9	3
F..67	2.7	3.8	1.9	3.8	2.9	3.2
F..77	5	7.3	4.3	8	6	6.3
F..87	10	13.0	7.7	13.8	10.8	11
F..97	18.5	22.5	12.6	25.0	18.5	20
F..107	24.5	32	19.5	37.5	27	27
F..127	39	55	34	61	45	46.5
F..157	68	103	62	104	85	77



Helical-bevel (K-) gear units

K.., KA..B, KH..B, KV..B:

Gear units	Fill quantity in liters					
	M1	M2	M3	M4	M5	M6
K..37	0.5	1	1	1.3	1	1
K..47	0.8	1.3	1.5	2	1.6	1.6
K..57	1.2	2.3	2.5	3	2.6	2.4
K..67	1.1	2.4	2.6	3.4	2.6	2.6
K..77	2.2	4.1	4.4	5.9	4.2	4.4
K..87	3.7	8	8.7	10.9	7.8	8
K..97	7	14	15.7	20	15.7	15.5
K..107	10	21	25.5	33.5	24	24
K..127	21	41.5	44	54	40	41
K..157	31	62	65	90	58	62
K..167	35	100	100	125	85	85
K..187	60	170	170	205	130	130

KF..:

Gear units	Fill quantity in liters					
	M1	M2	M3	M4	M5	M6
KF37	0.5	1.1	1.1	1.5	1	1
KF47	0.8	1.3	1.7	2.2	1.6	1.6
KF57	1.3	2.3	2.7	3	2.9	2.7
KF67	1.1	2.4	2.8	3.6	2.7	2.7
KF77	2.1	4.1	4.4	6	4.5	4.5
KF87	3.7	8.2	9	11.9	8.4	8.4
KF97	7	14.7	17.3	21.5	15.7	16.5
KF107	10	22	26	35	25	25
KF127	21	41.5	46	55	41	41
KF157	31	66	69	92	62	62

KA.., KH.., KV.., KAF.., KHF.., KVF.., KAZ.., KHZ.., KVZ..:

Gear units	Fill quantity in liters					
	M1	M2	M3	M4	M5	M6
K..37	0.5	1	1	1.4	1	1
K..47	0.8	1.3	1.6	2.1	1.6	1.6
K..57	1.3	2.3	2.7	3	2.9	2.7
K..67	1.1	2.4	2.7	3.6	2.6	2.6
K..77	2.1	4.1	4.6	6	4.4	4.4
K..87	3.7	8.2	8.8	11.1	8	8
K..97	7	14.7	15.7	20	15.7	15.7
K..107	10	20.5	24	32	24	24
K..127	21	41.5	43	52	40	40
K..157	31	66	67	87	62	62
KH167	35	100	100	125	85	85
KH187	60	170	170	205	130	130



*Spiroplan® (W-)
gear units*

The Spiroplan® gear units always have the same fill quantity, independent of the mounting position:

Gear units	Mounting position independent fill quantity in liters
W..10	0.16
W..20	0.26
W..30	0.5

*Helical-worm (S-)
gear units*

S...:

Gear units	Fill quantity in liters					
	M1	M2	M3 ¹⁾	M4	M5	M6
S37	0.25	0.4	0.5	0.6	0.4	0.4
S47	0.35	0.8	0.7/0.9	1.1	0.8	0.8
S57	0.5	1.2	1/1.2	1.5	1.3	1.3
S67	1	2.0	2.2/3.1	3.2	2.6	2.6
S77	1.9	4.2	3.7/5.4	6	4.4	4.4
S87	3.3	8.1	6.9/10.4	12	8.4	8.4
S97	6.8	15	13.4/18	22.5	17	17

1) The larger gear unit in multi-stage gear units must be filled with the larger oil quantity.

SF...:

Gear units	Fill quantity in liters					
	M1	M2	M3 ¹⁾	M4	M5	M6
SF37	0.25	0.4	0.5	0.6	0.4	0.4
SF47	0.4	0.9	0.9/1.1	1.2	1.0	1
SF57	0.5	1.2	1/1.5	1.6	1.4	1.4
SF67	1	2.2	2.3/3	3.2	2.7	2.7
SF77	1.9	4.1	3.9/5.8	6.5	4.9	4.9
SF87	3.8	8	7.1/10.1	12	9.1	9.1
SF97	7.4	15	13.8/18.8	23.6	18	18

1) The larger gear unit in multi-stage gear units must be filled with the larger oil quantity.

SA..., SH..., SAF..., SHF..., SAZ..., SHZ...:

Gear units	Fill quantity in liters					
	M1	M2	M3 ¹⁾	M4	M5	M6
S..37	0.25	0.4	0.5	0.6	0.4	0.4
S..47	0.4	0.8	0.7/0.9	1.1	0.8	0.8
S..57	0.5	1.1	1/1.5	1.6	1.2	1.2
S..67	1	2	1.8/2.6	2.9	2.5	2.5
S..77	1.8	3.9	3.6/5	5.9	4.5	4.5
S..87	3.8	7.4	6/8.7	11.2	8	8
S..97	7	14	11.4/16	21	15.7	15.7

1) The larger gear unit in multi-stage gear units must be filled with the larger oil quantity.



Addresses

Germany			
Headquarters Production Sales Service	Bruchsal	SEW-EURODRIVE GmbH & Co Ernst-Blickle-Straße 42 D-76646 Bruchsal P.O. Box Postfach 3023 · D-76642 Bruchsal	Tel. (0 72 51) 75-0 Fax (0 72 51) 75-19 70 http://www.SEW-EURODRIVE.de sew@sew-eurodrive.de
Production	Graben	SEW-EURODRIVE GmbH & Co Ernst-Blickle-Straße 1 D-76676 Graben-Neudorf P.O. Box Postfach 1220 · D-76671 Graben-Neudorf	Tel. (0 72 51) 75-0 Fax (0 72 51) 75-29 70 Telex 7 822 276
Assembly Service	Garbsen (near Hannover)	SEW-EURODRIVE GmbH & Co Alte Ricklinger Straße 40-42 D-30823 Garbsen P.O. Box Postfach 110453 · D-30804 Garbsen	Tel. (0 51 37) 87 98-30 Fax (0 51 37) 87 98-55
	Kirchheim (near München)	SEW-EURODRIVE GmbH & Co Domagkstraße 5 D-85551 Kirchheim	Tel. (0 89) 90 95 52-10 Fax (0 89) 90 95 52-50
	Langenfeld (near Düsseldorf)	SEW-EURODRIVE GmbH & Co Siemensstraße 1 D-40764 Langenfeld	Tel. (0 21 73) 85 07-30 Fax (0 21 73) 85 07-55
	Meerane (near Zwickau)	SEW-EURODRIVE GmbH & Co Dänkritzer Weg 1 D-08393 Meerane	Tel. (0 37 64) 76 06-0 Fax (0 37 64) 76 06-30
Additional addresses for service in Germany provided on request!			
France			
Production Sales Service	Hagenau	SEW-USOCOME SAS 48-54, route de Soufflenheim B. P. 185 F-67506 Hagenau Cedex	Tel. 03 88 73 67 00 Fax 03 88 73 66 00 http://www.usocomme.com sew@usocomme.com
Assembly Sales Service	Bordeaux	SEW-USOCOME SAS Parc d'activités de Magellan 62, avenue de Magellan - B. P. 182 F-33607 Pessac Cedex	Tel. 05 57 26 39 00 Fax 05 57 26 39 09
	Lyon	SEW-USOCOME SAS Parc d'Affaires Roosevelt Rue Jacques Tati F-69120 Vaulx en Velin	Tel. 04 72 15 37 00 Fax 04 72 15 37 15
	Paris	SEW-USOCOME SAS Zone industrielle 2, rue Denis Papin F-77390 Verneuil l'Etang	Tel. 01 64 42 40 80 Fax 01 64 42 40 88
Additional addresses for service in France provided on request!			
Argentina			
Assembly Sales Service	Buenos Aires	SEW EURODRIVE ARGENTINA S.A. Centro Industrial Garin, Lote 35 Ruta Panamericana Km 37,5 1619 Garin	Tel. (3327) 45 72 84 Fax (3327) 45 72 21 sewar@sew-eurodrive.com.ar
Australia			
Assembly Sales Service	Melbourne	SEW-EURODRIVE PTY. LTD. 27 Beverage Drive Tullamarine, Victoria 3043	Tel. (03) 99 33 10 00 Fax (03) 99 33 10 03
	Sydney	SEW-EURODRIVE PTY. LTD. 9, Sleigh Place, Wetherill Park New South Wales, 2164	Tel. (02) 97 25 99 00 Fax (02) 97 25 99 05
Austria			
Assembly Sales Service	Wien	SEW-EURODRIVE Ges.m.b.H. Richard-Strauss-Strasse 24 A-1230 Wien	Tel. (01) 6 17 55 00-0 Fax (01) 6 17 55 00-30 sew@sew-eurodrive.at



Belgium			
Assembly Sales Service	Brüssel	CARON-VECTOR S.A. Avenue Eiffel 5 B-1300 Wavre	Tel. (010) 23 13 11 Fax (010) 2313 36 http://www.caron-vector.be info@caron-vector.be
Brazil			
Production Sales Service	Sao Paulo	SEW DO BRASIL Motores-Redutores Ltda. Rodovia Presidente Dutra, km 208 CEP 07210-000 - Guarulhos - SP	Tel. (011) 64 60-64 33 Fax (011) 64 80 33 28 sew@sew.com.br
Additional addresses for service in Brazil provided on request!			
Bulgaria			
Sales	Sofia	BEVER-DRIVE GMBH Bogdanovetz Str.1 BG-1606 Sofia	Tel. (92) 9 53 25 65 Fax (92) 9 54 93 45 bever@mbox.infotel.bg
Canada			
Assembly Sales Service	Toronto	SEW-EURODRIVE CO. OF CANADA LTD. 210 Walker Drive Bramalea, Ontario L6T3W1	Tel. (905) 7 91-15 53 Fax (905) 7 91-29 99
	Vancouver	SEW-EURODRIVE CO. OF CANADA LTD. 7188 Honeyman Street Delta. B.C. V4G 1 E2	Tel. (604) 9 46-55 35 Fax (604) 946-2513
	Montreal	SEW-EURODRIVE CO. OF CANADA LTD. 2555 Rue Leger Street LaSalle, Quebec H8N 2V9	Tel. (514) 3 67-11 24 Fax (514) 3 67-36 77
Additional addresses for service in Canada provided on request!			
Chile			
Assembly Sales Service	Santiago de Chile	SEW-EURODRIVE CHILE Motores-Reductores LTDA. Panamericana Norte No 9261 Casilla 23 - Correo Quilicura RCH-Santiago de Chile	Tel. (02) 6 23 82 03+6 23 81 63 Fax (02) 6 23 81 79
China			
Production Assembly Sales Service	Tianjin	SEW-EURODRIVE (Tianjin) Co., Ltd. No. 46, 7th Avenue, TEDA Tianjin 300457	Tel. (022) 25 32 26 12 Fax (022) 25 32 26 11
Colombia			
Assembly Sales Service	Bogotá	SEW-EURODRIVE COLOMBIA LTDA. Calle 22 No. 132-60 Bodega 6, Manzana B Santafé de Bogotá	Tel. (0571) 5 47 50 50 Fax (0571) 5 47 50 44 sewcol@andinet.com
Croatia			
Sales Service	Zagreb	KOMPEKS d. o. o. PIT Erdödy 4 II HR 10 000 Zagreb	Tel. +385 14 61 31 58 Fax +385 14 61 31 58
Czech Republic			
Sales	Praha	SEW-EURODRIVE S.R.O. Business Centrum Praha Luná 591 16000 Praha 6	Tel. 02/20 12 12 34 + 20 12 12 36 Fax 02/20 12 12 37 sew@sew-eurodrive.cz
Denmark			
Assembly Sales Service	Kopenhagen	SEW-EURODRIVEA/S Geminivej 28-30, P.O. Box 100 DK-2670 Greve	Tel. 4395 8500 Fax 4395 8509 http://www.sew-eurodrive.dk sew@sew-eurodrive.dk
Estonia			
Sales	Tallin	ALAS-KUUL AS Paldiski mnt.125 EE 0006 Tallin	Tel. 6 59 32 30 Fax 6 59 32 31



Address list

Finland			
Assembly Sales Service	Lahti	SEW-EURODRIVE OY Vesimäentie 4 FIN-15860 Hollola 2	Tel. (3) 589 300 Fax (3) 780 6211
Great Britain			
Assembly Sales Service	Normanton	SEW-EURODRIVE Ltd. Beckbridge Industrial Estate P.O. Box No.1 GB-Normanton, West- Yorkshire WF6 1QR	Tel. 19 24 89 38 55 Fax 19 24 89 37 02
Greece			
Sales Service	Athen	Christ. Boznos & Son S.A. 12, Mavromichali Street P.O. Box 80136, GR-18545 Piraeus	Tel. 14 22 51 34 Fax 14 22 51 59 Boznos@otenet.gr
Hong Kong			
Assembly Sales Service	Hong Kong	SEW-EURODRIVE LTD. Unit No. 801-806, 8th Floor Hong Leong Industrial Complex No. 4, Wang Kwong Road Kowloon, Hong Kong	Tel. 2-7 96 04 77 + 79 60 46 54 Fax 2-7 95-91 29 sew@sewhk.com
Hungary			
Sales Service	Budapest	SEW-EURODRIVE Kft. H-1037 Budapest Kunigunda u. 18	Tel. +36 1 437 06 58 Fax +36 1 437 06 50
India			
Assembly Sales Service	Baroda	SEW-EURODRIVE India Pvt. Ltd. Plot No. 4, Gidc Por Ramangamdi · Baroda - 391 243 Gujarat	Tel. 0 265-83 10 86 Fax 0 265-83 10 87 sew.baroda@gecsl.com
Ireland			
Sales Service	Dublin	Alperon Engineering Ltd. 48 Moyle Road Dublin Industrial Estate Glasnevin, Dublin 11	Tel. (01) 8 30 62 77 Fax (01) 8 30 64 58
Italy			
Assembly Sales Service	Milano	SEW-EURODRIVE di R. Blickle & Co.s.a.s. Via Bernini,14 I-20020 Solaro (Milano)	Tel. (02) 96 98 01 Fax (02) 96 79 97 81
Japan			
Assembly Sales Service	Toyoda-cho	SEW-EURODRIVE JAPAN CO., LTD 250-1, Shimoman-no, Toyoda-cho, Iwata gun Shizuoka prefecture, P.O. Box 438-0818	Tel. (0 53 83) 7 3811-13 Fax (0 53 83) 7 3814
Korea			
Assembly Sales Service	Ansan-City	SEW-EURODRIVE KOREA CO., LTD. B 601-4, Banweol Industrial Estate Unit 1048-4, Shingil-Dong Ansan 425-120	Tel. (031) 4 92-80 51 Fax (031) 4 92-80 56
Luxembourg			
Assembly Sales Service	Brüssel	CARON-VECTOR S.A. Avenue Eiffel 5 B-1300 Wavre	Tel. (010) 23 13 11 Fax (010) 2313 36 http://www.caron-vector.be info@caron-vector.be
Macedonia			
Sales	Skopje	SGS-Skopje / Macedonia "Teodosij Sinactaski" 6691000 Skopje / Macedonia	Tel. (0991) 38 43 90 Fax (0991) 38 43 90
Malaysia			
Assembly Sales Service	Johore	SEW-EURODRIVE SDN BHD No. 95, Jalan Seroja 39, Taman Johor Jaya 81000 Johor Bahru, Johor West Malaysia	Tel. (07) 3 54 57 07 + 3 54 94 09 Fax (07) 3 5414 04



Netherlands			
Assembly Sales Service	Rotterdam	VECTOR Aandrijftechniek B.V. Industrieweg 175 NL-3044 AS Rotterdam Postbus 10085 NL-3004 AB Rotterdam	Tel. +31 10 44 63 700 Fax +31 10 41 55 552 http://www.vector.nu info@vector.nu
New Zealand			
Assembly Sales Service	Auckland	SEW-EURODRIVE NEW ZEALAND LTD. P.O. Box 58-428 82 Greenmount drive East Tamaki Auckland	Tel. 0064-9-2 74 56 27 Fax 0064-9-2 74 01 65 sales@sew-eurodrive.co.nz
	Christchurch	SEW-EURODRIVE NEW ZEALAND LTD. 10 Settlers Crescent, Ferrymead Christchurch	Tel. (09) 3 84 62 51 Fax (09) 3 84 64 55 sales@sew-eurodrive.co.nz
Norway			
Assembly Sales Service	Moss	SEW-EURODRIVE A/S Solgaard skog 71 N-1599 Moss	Tel. (69) 2410 20 Fax (69) 2410 40 sew@sew-eurodrive.no
Peru			
Assembly Sales Service	Lima	SEW DEL PERU MOTORES REDUCTORES S.A.C. Los Calderos # 120-124 Urbanizacion Industrial Vulcano, ATE, Lima	Tel. (511) 349-52 80 Fax (511) 349-30 02 sewperu@terra.com.pe
Poland			
Sales	Lodz	SEW-EURODRIVE Polska Sp.z.o.o. ul. Pojezierska 63 91-338 Lodz	Tel. (042) 6 16 22 00 Fax (042) 6 16 22 10 sew@sew-eurodrive.pl
Portugal			
Assembly Sales Service	Coimbra	SEW-EURODRIVE, LDA. Apartado 15 P-3050-901 Mealhada	Tel. (0231) 20 96 70 Fax (0231) 20 36 85 infosew@sew-eurodrive.pt
Romania			
Sales Service	Bucuresti	Sialco Trading SRL str. Madrid nr.4 71222 Bucuresti	Tel. (01) 2 30 13 28 Fax (01) 2 30 71 70 sialco@mediasat.ro
Russia			
Sales	St. Petersburg	ZAO SEW-EURODRIVE P.O. Box 193 193015 St. Petersburg	Tel. (812) 3 26 09 41 + 5 35 04 30 Fax (812) 5 35 22 87 sewrus@post.spbnit.ru
Singapore			
Assembly Sales Service		SEW-EURODRIVE PTE. LTD. No 9, Tuas Drive 2 Jurong Industrial Estate Singapore 638644	Tel. 8 62 17 01-705 Fax 8 61 28 27 Telex 38 659
Slovenia			
Sales Service	Celje	Pakman - Pogonska Tehnika d.o.o. Ul. XIV. divizije 14 SLO – 3000 Celje	Tel. 00386 3 490 83 20 Fax 00386 3 490 83 21 pakman@siol.net



Address list

South Africa			
Assembly Sales Service	Johannesburg	SEW-EURODRIVE (PROPRIETARY) LIMITED Eurodrive House Cnr. Adcock Ingram and Aerodrome Roads Aeroton Ext. 2 Johannesburg 2013 P.O.Box 90004 Bertsham 2013	Tel. + 27 11 248 70 00 Fax +27 11 494 23 11
	Capetown	SEW-EURODRIVE (PROPRIETARY) LIMITED Rainbow Park Cnr. Racecourse & Omuramba Road Montague Gardens Cape Town P.O.Box 36556 Chempet 7442 Cape Town	Tel. +27 21 552 98 20 Fax +27 21 552 98 30 Telex 576 062
	Durban	SEW-EURODRIVE (PROPRIETARY) LIMITED 2 Monaceo Place Pinetown Durban P.O. Box 10433, Ashwood 3605	Tel. +27 31 700 34 51 Fax +27 31 700 38 47
Spain			
Assembly Sales Service	Bilbao	SEW-EURODRIVE ESPAÑA, S.L. Parque Tecnológico, Edificio, 302 E-48170 Zamudio (Vizcaya)	Tel. 9 44 31 84 70 Fax 9 44 31 84 71 sew.spain@sew-eurodrive.es
Sweden			
Assembly Sales Service	Jönköping	SEW-EURODRIVE AB Gnejsvägen 6-8 S-55303 Jönköping Box 3100 S-55003 Jönköping	Tel. (036) 34 42 00 Fax (036) 34 42 80 www.sew-eurodrive.se
Switzerland			
Assembly Sales Service	Basel	Alfred Imhof A.G. Jurastrasse 10 CH-4142 Münchenstein bei Basel	Tel. (061) 4 17 17 17 Fax (061) 4 17 17 00 http://www.imhof-sew.ch info@imhof-sew.ch
Thailand			
Assembly Sales Service	Chon Buri	SEW-EURODRIVE (Thailand) Ltd. Bangpakong Industrial Park 2 700/456, Moo.7, Tambol Donhuaroh Muang District Chon Buri 20000	Tel. 0066-38 21 40 22 Fax 0066-38 21 45 31
Turkey			
Assembly Sales Service	Istanbul	SEW-EURODRIVE Hareket Sistemleri San. ve Tic. Ltd. Sti Bagdat Cad. Koruma Cikmazi No. 3 TR-81540 Maltepe ISTANBUL	Tel. (0216) 4 41 91 63 + 4 41 91 64 + 3 83 80 14 + 3 83 80 15 Fax (0216) 3 05 58 67 seweurodrive@superonline.com.tr
USA			
Production Assembly Sales Service	Greenville	SEW-EURODRIVE INC. 1295 Old Spartanburg Highway P.O. Box 518 Lyman, S.C. 29365	Tel. (864) 4 39 75 37 Fax Sales (864) 439-78 30 Fax Manuf. (864) 4 39-99 48 Fax Ass. (864) 4 39-05 66 Telex 805 550
Assembly Sales Service	San Francisco	SEW-EURODRIVE INC. 30599 San Antonio St. Hayward, California 94544-7101	Tel. (510) 4 87-35 60 Fax (510) 4 87-63 81
	Philadelphia/PA	SEW-EURODRIVE INC. Pureland Ind. Complex 200 High Hill Road, P.O. Box 481 Bridgeport, New Jersey 08014	Tel. (856) 4 67-22 77 Fax (856) 8 45-31 79
	Dayton	SEW-EURODRIVE INC. 2001 West Main Street Troy, Ohio 45373	Tel. (9 37) 3 35-00 36 Fax (9 37) 4 40-37 99
	Dallas	SEW-EURODRIVE INC. 3950 Platinum Way Dallas, Texas 75237	Tel. (214) 3 30-48 24 Fax (214) 3 30-47 24



USA			
Additional addresses for service in the USA provided on request!			
Venezuela			
Assembly Sales Service	Valencia	SEW-EURODRIVE Venezuela S.A. Av. Norte Sur No. 3, Galpon 84-319 Zona Industrial Municipal Norte Valencia	Tel. +58 (241) 8 32 98 04 Fax +58 (241) 8 38 62 75 sewventas@cantr.net sewfinanzas@cantr.net

SEW-EURODRIVE GmbH & Co · P.O. Box 3023 · D-76642 Bruchsal/Germany · Phone +49-7251-75-0
Fax +49-7251-75-1970 · <http://www.sew-eurodrive.com> · sew@sew-eurodrive.com

SEW
EURODRIVE

