

SIEMENS

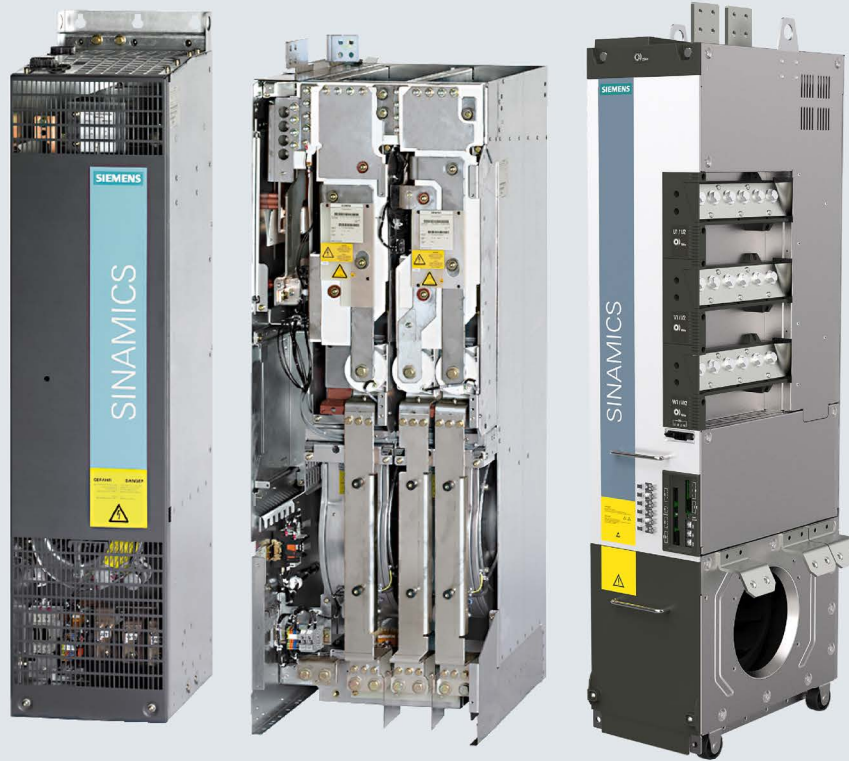

Equipment Manual

SINAMICS

S120

Air-cooled chassis power units

Edition

03/2018

www.siemens.com/drives

SIEMENS

SINAMICS

S120 Air-cooled chassis power units

Manual

Preface

Fundamental safety instructions **1**

System overview **2**

Line-side power components **3**

Line Modules **4**

Motor Modules **5**

Motor Modules Chassis-2 **6**

DC link components **7**

Motor-side power components **8**

Cabinet design and EMC **9**

Maintenance and Servicing **10**

Appendix **A**

Legal information

Warning notice system

This manual contains notices you have to observe in order to ensure your personal safety, as well as to prevent damage to property. The notices referring to your personal safety are highlighted in the manual by a safety alert symbol, notices referring only to property damage have no safety alert symbol. These notices shown below are graded according to the degree of danger.

 DANGER

indicates that death or severe personal injury will result if proper precautions are not taken.
--

 WARNING
--

indicates that death or severe personal injury may result if proper precautions are not taken.

 CAUTION
--

indicates that minor personal injury can result if proper precautions are not taken.
--

NOTICE

indicates that property damage can result if proper precautions are not taken.
--

If more than one degree of danger is present, the warning notice representing the highest degree of danger will be used. A notice warning of injury to persons with a safety alert symbol may also include a warning relating to property damage.

Qualified Personnel

The product/system described in this documentation may be operated only by **personnel qualified** for the specific task in accordance with the relevant documentation, in particular its warning notices and safety instructions. Qualified personnel are those who, based on their training and experience, are capable of identifying risks and avoiding potential hazards when working with these products/systems.

Proper use of Siemens products

Note the following:

 WARNING
--

Siemens products may only be used for the applications described in the catalog and in the relevant technical documentation. If products and components from other manufacturers are used, these must be recommended or approved by Siemens. Proper transport, storage, installation, assembly, commissioning, operation and maintenance are required to ensure that the products operate safely and without any problems. The permissible ambient conditions must be complied with. The information in the relevant documentation must be observed.
--

Trademarks

All names identified by ® are registered trademarks of Siemens AG. The remaining trademarks in this publication may be trademarks whose use by third parties for their own purposes could violate the rights of the owner.

Disclaimer of Liability

We have reviewed the contents of this publication to ensure consistency with the hardware and software described. Since variance cannot be precluded entirely, we cannot guarantee full consistency. However, the information in this publication is reviewed regularly and any necessary corrections are included in subsequent editions.

Preface

SINAMICS documentation

The SINAMICS documentation is organized in the following categories:

- General documentation/catalogs
- User documentation
- Manufacturer/service documentation

Additional information

Using the following link, you can find information on the topics:

- Ordering documentation / overview of documentation
- Additional links to download documents
- Using documentation online (find and search in manuals/information)

<http://www.siemens.com/motioncontrol/docu>

Please send any questions about the technical documentation (e.g. suggestions for improvement, corrections) to the following e-mail address:

docu.motioncontrol@siemens.com

My Documentation Manager

Using the following link, you can find information on how to create your own individual documentation based on Siemens' content, and adapt it for your own machine documentation:

<http://www.siemens.com/mdm>

Training

Using the following link, you can find information on SITRAIN – training from Siemens for products, systems and drive technology solutions:

<http://www.siemens.com/sitrain>

FAQs

You can find Frequently Asked Questions in the Service&Support pages under **Product Support**:

<https://support.industry.siemens.com/cs>

SINAMICS

You can find information on SINAMICS under:

<http://www.siemens.com/sinamics>

Usage phases and the available tools/documents

Table 1 Usage phases and the available tools/documents

Usage phase	Tools
Orientation	SINAMICS S sales documentation
Planning/engineering	<ul style="list-style-type: none"> • SIZER engineering tool • SINAMICS Low Voltage Configuration Manual • Configuration manuals, motors
Decision making/ordering	SINAMICS S120 catalogs <ul style="list-style-type: none"> • SINAMICS S120 and SIMOTICS (Catalog D 21.4) • SINAMICS S120 Chassis Format Units and Cabinet Modules, SINAMICS S150 Converter Cabinet Units (Catalog D 21.3)
Configuring/installation	<ul style="list-style-type: none"> • SINAMICS S120 Manual for Control Units and Additional System Components • SINAMICS S120 Manual for Booksize Power Units • SINAMICS S120 Manual for Air-Cooled Chassis Power Units • SINAMICS S120 Manual for Liquid-Cooled Chassis Power Units • SINAMICS S120 Equipment Manual water-cooled chassis power units for common cooling circuits • SINAMICS S120 Manual for AC Drives • SINAMICS S120M Manual for Distributed Drive Technology
Commissioning	<ul style="list-style-type: none"> • STARTER Commissioning Tool • SINAMICS S120 Getting Started • SINAMICS S120 Commissioning Manual • SINAMICS S120 CANopen Commissioning Manual • SINAMICS S120 Drive Functions Function Manual • SINAMICS S120 Safety Integrated Function Manual • SINAMICS S120/S150 List Manual
Using/operating	<ul style="list-style-type: none"> • SINAMICS S120 Commissioning Manual • SINAMICS S120 Drive Functions Function Manual • SINAMICS S120/S150 List Manual
Maintenance/Service	<ul style="list-style-type: none"> • SINAMICS S120 Manual for Control Units and Additional System Components • SINAMICS S120 Manual for Booksize Power Units • SINAMICS S120 Manual for Air-Cooled Chassis Power Units • SINAMICS S120 Manual for Liquid-Cooled Chassis Power Units • SINAMICS S120 Equipment Manual water-cooled chassis power units for common cooling circuits • SINAMICS S120 Commissioning Manual • SINAMICS S120/S150 List Manual
List of references	<ul style="list-style-type: none"> • SINAMICS S120/S150 List Manual

Target group

This documentation is intended for machine manufacturers, commissioning engineers, and service personnel who use the SINAMICS drive system.

Benefits

This manual provides all the information, procedures and operational instructions required for commissioning and servicing SINAMICS S120.

Standard scope

The scope of the functionality described in this document can differ from the scope of the functionality of the drive system that is actually supplied.

- Other functions not described in this documentation might be able to be executed in the drive system. This does not, however, represent an obligation to supply such functions with a new controller or when servicing.
- The documentation can also contain descriptions of functions that are not available in a particular product version of the drive system. The functionalities of the supplied drive system should only be taken from the ordering documentation.
- Extensions or changes made by the machine manufacturer must be documented by the machine manufacturer.

For reasons of clarity, this documentation does not contain all of the detailed information on all of the product types. This documentation cannot take into consideration every conceivable type of installation, operation and service/maintenance.

Technical support

Country-specific telephone numbers for technical support are provided in the Internet under **Contact:**

<https://support.industry.siemens.com/sc/ww/en/sc/2090>

EC declaration of conformity

The EC Declaration of Conformity for the EMC Directive can be found on the Internet at:
<https://support.industry.siemens.com/cs/ww/en/ps/13231/cert>

Alternatively, you can contact the Siemens office in your region in order to obtain the EC Declaration of Conformity.

Note

Complying with the low-voltage directive

In the operational state – and when installed in dry electrical rooms – SINAMICS S devices are in compliance with 2014/35/EU.

Note

Fulfilling the EMC Directive

SINAMICS S units fulfill EMC Directive 2014/30/EU in the configuration specified in the associated EC Declaration of Conformity for EMC and when the EMC installation guideline provided in the Configuration Manual with Article No. 6FC5297-0AD30-0AP3 is implemented.

Note

Machinery directive

The devices satisfy the requirements according to Machinery Directive 2006/42/EC for the Safety Integrated safety functions.

Note

Ensuring reliable operation

The manual describes a desired state. The required reliable operation and the compliance with EMC limit values can only be ensured when this is maintained.

EMC limit values for South Korea

<p>이 기기는 업무용(A급) 전자파적합기기로서 판매자 또는 사용자는 이 점을 주의하시기 바라며, 가정외의 지역에서 사용하는 것을 목적으로 합니다. For sellers or other user, please keep in mind that this device in an A-grade electromagnetic wave device. This device is intended to be used in areas other than home.</p>
--

The mandatory EMC limits for Korea correspond to the limits of EN 61800-3 (EMC product standard for adjustable speed electrical drive systems) for category C2 or to limit class A, Group 1 according to EN 55011.

Compliance with the limits according to category C2 or class A, group 1 is achieved with suitable additional measures. Furthermore, additional measures such as the use of an additional radio interference suppression filter (EMC filter) may be required.

In addition, measures for proper plant design to meet EMC requirements are described in detail in this manual and the "SINAMICS Low Voltage Configuration Manual".

Spare parts

Spare parts are available on the Internet at:
<https://support.industry.siemens.com/sc/de/en/sc/2110>

Test certificates

Test certificates for functional safety functions ("Safety Integrated") can be found at:
<https://support.industry.siemens.com/cs>

An up-to-date list of currently certified components is also available on request from your local Siemens office. If you have any questions relating to certifications that have not yet been completed, please ask your Siemens contact.

Note on the installation of a UL-approved system

Note

Installation of a UL-approved system

For a UL-approved system use 60/75 °C copper conductors only.

Table of contents

	Preface	3
1	Fundamental safety instructions	15
1.1	General safety instructions	15
1.2	Handling electrostatic sensitive devices (ESD)	20
1.3	Industrial security	21
1.4	Residual risks of power drive systems.....	22
2	System overview.....	23
2.1	The SINAMICS range of drives	23
2.2	SINAMICS S120 drive system	26
2.3	Technical specifications.....	30
2.4	Derating factors as a function of installation altitude and ambient temperature.....	33
2.5	Standards.....	35
2.6	Basic structure of a drive system with SINAMICS S120	38
2.6.1	Structure of a drive system with SINAMICS S120 and regulated infeed.....	38
2.6.2	Structure of a drive system with SINAMICS S120 and uncontrolled infeed/regenerative feedback unit.....	39
2.6.3	Structure of a drive system with SINAMICS S120 and unregulated infeed.....	40
3	Line-side power components	41
3.1	General	41
3.2	Line filters for Basic Line Modules	41
3.2.1	Description	41
3.2.2	Safety information	42
3.2.3	Dimension drawing	45
3.2.4	Technical data.....	47
3.3	Line filters for Smart Line Modules and Active Line Modules.....	49
3.3.1	Description	49
3.3.2	Safety information	49
3.3.3	Dimension drawing	52
3.3.4	Technical data.....	55
3.4	Line reactors for Basic Line Modules.....	56
3.4.1	Description	56
3.4.2	Safety information	56
3.4.3	Dimension drawing	58
3.4.4	Technical data.....	60
3.5	Line reactors for Smart Line Modules.....	62
3.5.1	Description	62
3.5.2	Safety information	62

3.5.3	Dimension drawing	64
3.5.4	Technical data.....	70
3.6	Active Interface Modules.....	71
3.6.1	Description	71
3.6.2	Safety information	72
3.6.3	Interface description.....	73
3.6.3.1	Overview	73
3.6.3.2	Connection example	77
3.6.3.3	Line/load connection	79
3.6.3.4	DRIVE-CLiQ interface X500	79
3.6.3.5	X530 neutral point grounding.....	80
3.6.3.6	X609 terminal strip	81
3.6.3.7	Meaning of the LED on the Voltage Sensing Module (VSM) in the Active Interface Module	82
3.6.4	Dimension drawing	83
3.6.5	Electrical connection	87
3.6.6	Technical data.....	93
4	Line Modules	97
4.1	Introduction	97
4.2	Basic Line Modules.....	98
4.2.1	Description	98
4.2.2	Safety information	100
4.2.3	Interface description.....	102
4.2.3.1	Overview	102
4.2.3.2	Connection example	104
4.2.3.3	Line/load connection	106
4.2.3.4	X9 terminal strip	107
4.2.3.5	X41 EP terminal / temperature sensor connection	108
4.2.3.6	X42 terminal strip	109
4.2.3.7	DRIVE-CLiQ interfaces X400, X401, X402.....	110
4.2.3.8	Meaning of the LEDs on the Control Interface Module in the Basic Line Module	111
4.2.4	Dimension drawing	112
4.2.5	Electrical connection	114
4.2.6	Precharging circuit for the Basic Line Modules, frame size GD	118
4.2.7	Technical data.....	121
4.3	Smart Line Modules	130
4.3.1	Description	130
4.3.2	Safety information	133
4.3.3	Interface description.....	136
4.3.3.1	Overview	136
4.3.3.2	Connection example	139
4.3.3.3	Line/load connection	140
4.3.3.4	X9 terminal strip	141
4.3.3.5	X41 EP terminal / temperature sensor connection	141
4.3.3.6	X42 terminal strip	143
4.3.3.7	DRIVE-CLiQ interfaces X400, X401, X402.....	143
4.3.3.8	Meaning of the LEDs on the Control Interface Module in the Smart Line Module	144
4.3.4	Dimension drawing	145
4.3.5	Electrical connection	148
4.3.6	Technical data.....	154

4.4	Active Line Modules	161
4.4.1	Description	161
4.4.2	Safety information	164
4.4.3	Interface description.....	167
4.4.3.1	Overview	167
4.4.3.2	Connection example	171
4.4.3.3	Line/load connection	172
4.4.3.4	X9 terminal strip	173
4.4.3.5	X41 EP terminal / temperature sensor connection	173
4.4.3.6	X42 terminal strip	175
4.4.3.7	DRIVE-CLiQ interfaces X400, X401, X402	175
4.4.3.8	Meaning of the LEDs on the Control Interface Module in the Active Line Module	176
4.4.4	Dimension drawing	177
4.4.5	Electrical connection.....	181
4.4.6	Technical specifications.....	183
5	Motor Modules.....	193
5.1	Description	193
5.2	Safety information	195
5.3	Interface description.....	197
5.3.1	Overview	197
5.3.2	Connection example	201
5.3.3	DC link/motor connection.....	202
5.3.4	X9 terminal strip	203
5.3.5	DCPS, DCNS connection for a dv/dt filter	203
5.3.6	X41 EP terminal / temperature sensor connection	204
5.3.7	X42 terminal strip	205
5.3.8	X46 Brake control and monitoring	206
5.3.9	DRIVE-CLiQ interfaces X400, X401, X402	206
5.3.10	Meaning of the LEDs on the Control Interface Module in the Motor Module	207
5.4	Dimension drawing	208
5.5	Electrical connection	212
5.6	Technical specifications.....	214
5.6.1	Motor Modules, 510 ... 720 V DC (line voltage 3 AC 380 ... 480 V)	214
5.6.2	Motor Modules, 675 ... 1035 V DC (line voltage 3 AC 500 ... 690 V)	220
5.6.3	Overload capability	227
5.6.4	Current de-rating depending on the pulse frequency	229
5.6.5	Parallel connection of Motor Modules.....	231
6	Motor Modules Chassis-2	233
6.1	Description	233
6.2	Safety information	235
6.3	Interface description.....	237
6.3.1	Overview	237
6.3.2	Connection example	238
6.3.3	DC link/motor connection.....	239
6.3.4	X51 connection, fan power supply.....	240
6.3.5	X9 terminal strip	241
6.3.6	X41 EP terminal / temperature sensor connection	242

6.3.7	X42 terminal strip	244
6.3.8	X46 Brake control and monitoring.....	244
6.3.9	X47 contactor feedback signal.....	245
6.3.10	X49 terminal block	246
6.3.11	DRIVE-CLiQ interfaces X400, X401, X402.....	246
6.3.12	Meaning of the LEDs on the Motor Module	247
6.4	Dimension drawing	248
6.5	Installation	249
6.6	Electrical connection	250
6.7	Technical data.....	253
6.7.1	Motor Modules, 510 ... 720 V DC (line voltage 3 AC 380 ... 480 V).....	253
6.7.2	Overload capability	254
6.7.3	Current de-rating depending on the pulse frequency	257
6.7.4	Parallel connection of Motor Modules.....	258
7	DC link components.....	259
7.1	Braking Module	259
7.1.1	Description	259
7.1.2	Safety information	261
7.1.3	Interface description.....	262
7.1.3.1	Braking Module for frame sizes FX, FB.....	262
7.1.3.2	Braking Module for frame sizes GX, GB, GD	263
7.1.3.3	Braking Module for frame sizes HX, JX	264
7.1.3.4	Connection example	265
7.1.3.5	Braking resistor connection.....	265
7.1.3.6	X21 digital inputs/outputs.....	266
7.1.3.7	S1 Threshold switch.....	267
7.1.4	Installation.....	269
7.1.4.1	Installing the Braking Module in an Active Line Module / Motor Module, frame size FX.....	269
7.1.4.2	Installing the Braking Module in a Smart Line Module / Active Line Module / Motor Module, frame size GX	272
7.1.4.3	Installing the Braking Module in a Smart Line Module / Active Line Module / Motor Module, frame size HX.....	275
7.1.4.4	Installing the Braking Module in a Smart Line Module / Active Line Module / Motor Module, frame size JX	276
7.1.4.5	Installing the Braking Module in a Basic Line Module, frame size FB.....	277
7.1.4.6	Installing the Braking Module in a Basic Line Module, frame size GB, GD.....	279
7.1.5	Technical specifications	281
7.2	Braking resistors	284
7.2.1	Description	284
7.2.2	Safety information	285
7.2.3	Dimension drawing	287
7.2.4	Electrical connection	288
7.2.5	Technical data.....	288

8	Motor-side power components	291
8.1	Sine-wave filter	291
8.1.1	Description	291
8.1.2	Safety information	292
8.1.3	Dimension drawing	294
8.1.4	Technical data	295
8.2	Motor reactors	296
8.2.1	Description	296
8.2.2	Safety information	298
8.2.3	Dimension drawing	300
8.2.4	Technical data	304
8.3	dV/dt filter plus Voltage Peak Limiter	308
8.3.1	Description	308
8.3.2	Safety information	310
8.3.3	Interface description	313
8.3.4	Connecting the dV/dt filter plus Voltage Peak Limiter	315
8.3.5	Dimension drawing, dV/dt reactor	318
8.3.6	Dimension drawing of the Voltage Peak Limiter	321
8.3.7	Technical data	324
8.4	dV/dt filter compact plus Voltage Peak Limiter	328
8.4.1	Description	328
8.4.2	Safety information	330
8.4.3	Interface description	333
8.4.4	Connecting the dV/dt filter compact plus Voltage Peak Limiter	335
8.4.5	Dimension drawing for dV/dt filter compact plus Voltage Peak Limiter	338
8.4.6	Technical data	343
9	Cabinet design and EMC	349
9.1	Information	349
9.1.1	General	349
9.1.2	Safety information	350
9.1.3	Directives	351
9.2	EMC-compliant design and control cabinet configuration	352
9.3	Cabinet air conditioning	352
9.3.1	General	352
9.3.2	Ventilation	353
10	Maintenance and Servicing	365
10.1	Chapter content	365
10.2	Maintenance	366
10.3	Maintenance	367
10.3.1	Installation device	368
10.3.2	Using crane lifting lugs to transport power blocks	369
10.4	Replacing components	373
10.4.1	Safety information	373
10.4.2	Messages after replacement of DRIVE-CLiQ components	373
10.4.3	Replacing the power block, Active Line Module, and Motor Module, frame size FX	375

10.4.4	Replacing the power block, Smart Line Module, Active Line Module, and Motor Module, frame size GX	378
10.4.5	Replacing the power block, Smart Line Module, Active Line Module, and Motor Module, frame size HX.....	381
10.4.6	Replacing the power block, Smart Line Module, Active Line Module, and Motor Module, frame size JX	386
10.4.7	Replacing the power block, Basic Line Module, frame size FB.....	388
10.4.8	Replacing the power block, Basic Line Module GB, GD.....	391
10.4.9	Replacing the Control Interface Module, Active Line Module and Motor Module, frame size FX	394
10.4.10	Replacing the Control Interface Module, Smart Line Module, Active Line Module, and Motor Module, frame size GX	396
10.4.11	Replacing the Control Interface Module, Smart Line Module, Active Line Module, and Motor Module, frame size HX	398
10.4.12	Replacing the Control Interface Module, Smart Line Module, Active Line Module, and Motor Module, frame size JX	400
10.4.13	Replacing the Control Interface Module, Motor Module Chassis-2, frame size FS4.....	402
10.4.14	Replacing the Control Interface Module, Basic Line Module, frame size FB	405
10.4.15	Replacing the Control Interface Module, Basic Line Module, frame size GB, GD	407
10.4.16	Replacing the fan, Smart Line Module, Active Line Module, and Motor Module, frame sizes FX, GX.....	409
10.4.17	Replacing the fan, Smart Line Module, Active Line Module, and Motor Module, frame size HX.....	411
10.4.18	Replacing the fan, Smart Line Module, Active Line Module, and Motor Module, frame size JX.....	415
10.4.19	Replacing the fan, Motor Module Chassis-2, frame size FS4	417
10.4.20	Replacing the electronic fan, Motor Module Chassis-2, frame size FS4.....	419
10.4.21	Replacing the fan, Active Interface Module, frame size FI	422
10.4.22	Replacing the fan, Active Interface Module, frame size GI.....	424
10.4.23	Replacing the fan, Active Interface Module, frame size HI.....	426
10.4.24	Replacing the fan, Active Interface Module, frame size JI.....	428
10.4.25	Replacing the fan, Basic Line Module, frame sizes FB, GB, GD.....	430
10.4.26	Replacing the DC fuses, Smart Line Module, Active Line Module, and Motor Module, frame size HX.....	432
10.4.27	Replacing the DC fuses, Smart Line Module, Active Line Module, and Motor Module, frame size JX	435
10.4.28	Replacing the fan fuses (-F10/-F11)	437
10.5	Forming the DC link capacitors.....	437
A	Appendix.....	443
A.1	Cable lugs	443
A.2	List of abbreviations	444
	Index.....	449

Fundamental safety instructions

1.1 General safety instructions



! WARNING

Electric shock and danger to life due to other energy sources

Touching live components can result in death or serious injury.

- Only work on electrical devices when you are qualified for this job.
- Always observe the country-specific safety rules.

Generally, the following steps apply when establishing safety:

1. Prepare for disconnection. Notify all those who will be affected by the procedure.
2. Isolate the drive system from the power supply and take measures to prevent it being switched back on again.
3. Wait until the discharge time specified on the warning labels has elapsed.
4. Check that there is no voltage between any of the power connections, and between any of the power connections and the protective conductor connection.
5. Check whether the existing auxiliary supply circuits are de-energized.
6. Ensure that the motors cannot move.
7. Identify all other hazardous energy sources, e.g. compressed air, hydraulic systems, water. Switch the energy sources to a safe state.
8. Check that the correct drive system is completely locked.

After you have completed the work, restore the operational readiness in the inverse sequence.



! WARNING

Electric shock due to connection to an unsuitable power supply

When equipment is connected to an unsuitable power supply, exposed components may carry a hazardous voltage that might result in serious injury or death.

- Only use power supplies that provide SELV (Safety Extra Low Voltage) or PELV (Protective Extra Low Voltage) output voltages for all connections and terminals of the electronics modules.



 WARNING
Electric shock due to equipment damage
Improper handling may cause damage to equipment. For damaged devices, hazardous voltages can be present at the enclosure or at exposed components; if touched, this can result in death or severe injury.
<ul style="list-style-type: none">• Ensure compliance with the limit values specified in the technical data during transport, storage and operation.• Do not use any damaged devices.



 WARNING
Electric shock due to unconnected cable shield
Hazardous touch voltages can occur through capacitive cross-coupling due to unconnected cable shields.
<ul style="list-style-type: none">• As a minimum, connect cable shields and the cores of power cables that are not used (e.g. brake cores) at one end at the grounded housing potential.



 WARNING
Electric shock if there is no ground connection
For missing or incorrectly implemented protective conductor connection for devices with protection class I, high voltages can be present at open, exposed parts, which when touched, can result in death or severe injury.
<ul style="list-style-type: none">• Ground the device in compliance with the applicable regulations.



 WARNING
Arcing when a plug connection is opened during operation
Opening a plug connection when a system is in operation can result in arcing that may cause serious injury or death.
<ul style="list-style-type: none">• Only open plug connections when the equipment is in a voltage-free state, unless it has been explicitly stated that they can be opened in operation.



 WARNING
Electric shock due to residual charges in power components
Because of the capacitors, a hazardous voltage is present for up to 5 minutes after the power supply has been switched off. Contact with live parts can result in death or serious injury.
<ul style="list-style-type: none">• Wait for 5 minutes before you check that the unit really is in a no-voltage condition and start work.

NOTICE**Property damage due to loose power connections**

Insufficient tightening torques or vibration can result in loose power connections. This can result in damage due to fire, device defects, or malfunctions.

- Tighten all power connections to the prescribed torque.
- Check all power connections at regular intervals, particularly after equipment has been transported.

 **WARNING****Spread of fire from built-in devices**

In the event of fire outbreak, the enclosures of built-in devices cannot prevent the escape of fire and smoke. This can result in serious injury or property damage.

- Install built-in units in a suitable metal cabinet in such a way that personnel are protected against fire and smoke, or take other appropriate measures to protect personnel.
- Ensure that smoke can only escape via controlled and monitored paths.

 **WARNING****Failure of pacemakers or implant malfunctions due to electromagnetic fields**

Electromagnetic fields (EMF) are generated by the operation of electrical power equipment, such as transformers, converters, or motors. People with pacemakers or implants in the immediate vicinity of this equipment are at particular risk.

- If you have a heart pacemaker or implant, maintain a minimum distance of 2 m from electrical power equipment.

 **WARNING****Unexpected movement of machines caused by radio devices or mobile phones**

When radio devices or mobile phones with a transmission power > 1 W are used in the immediate vicinity of components, they may cause the equipment to malfunction.

Malfunctions may impair the functional safety of machines and can therefore put people in danger or lead to property damage.

- If you come closer than around 2 m to such components, switch off any radio devices or mobile phones.
- Use the "SIEMENS Industry Online Support App" only on equipment that has already been switched off.

 WARNING
Motor fire in the event of insulation overload
<p>There is a greater load on the motor insulation through a ground fault in an IT system. If the insulation fails, it is possible that death or severe injury can occur as a result of smoke and fire.</p>
<ul style="list-style-type: none">• Use a monitoring device that signals an insulation fault.• Correct the fault as quickly as possible so the motor insulation is not overloaded.

 WARNING
Fire due to inadequate ventilation clearances
<p>Inadequate ventilation clearances can cause overheating of components with subsequent fire and smoke. This can cause severe injury or even death. This can also result in increased downtime and reduced service lives for devices/systems.</p>
<ul style="list-style-type: none">• Ensure compliance with the specified minimum clearance as ventilation clearance for the respective component.

 WARNING
Unrecognized dangers due to missing or illegible warning labels
<p>Dangers might not be recognized if warning labels are missing or illegible. Unrecognized dangers may cause accidents resulting in serious injury or death.</p>
<ul style="list-style-type: none">• Check that the warning labels are complete based on the documentation.• Attach any missing warning labels to the components, where necessary in the national language.• Replace illegible warning labels.

NOTICE
Device damage caused by incorrect voltage/insulation tests
<p>Incorrect voltage/insulation tests can damage the device.</p>
<ul style="list-style-type: none">• Before carrying out a voltage/insulation check of the system/machine, disconnect the devices as all converters and motors have been subject to a high voltage test by the manufacturer, and therefore it is not necessary to perform an additional test within the system/machine.

 **WARNING**

Unexpected movement of machines caused by inactive safety functions

Inactive or non-adapted safety functions can trigger unexpected machine movements that may result in serious injury or death.

- Observe the information in the appropriate product documentation before commissioning.
- Carry out a safety inspection for functions relevant to safety on the entire system, including all safety-related components.
- Ensure that the safety functions used in your drives and automation tasks are adjusted and activated through appropriate parameterizing.
- Run a function test.
- Only put your plant into live operation once you have guaranteed that the functions relevant to safety are running correctly.

Note

Important safety instructions for Safety Integrated functions

If you want to use Safety Integrated functions, you must observe the safety instructions in the Safety Integrated manuals.

1.2 Handling electrostatic sensitive devices (ESD)

Electrostatic sensitive devices (ESD) are individual components, integrated circuits, modules or devices that may be damaged by either electric fields or electrostatic discharge.



NOTICE

Damage through electric fields or electrostatic discharge

Electric fields or electrostatic discharge can cause malfunctions through damaged individual components, integrated circuits, modules or devices.

- Only pack, store, transport and send electronic components, modules or devices in their original packaging or in other suitable materials, e.g. conductive foam rubber or aluminum foil.
- Only touch components, modules and devices when you are grounded by one of the following methods:
 - Wearing an ESD wrist strap
 - Wearing ESD shoes or ESD grounding straps in ESD areas with conductive flooring
- Only place electronic components, modules or devices on conductive surfaces (table with ESD surface, conductive ESD foam, ESD packaging, ESD transport container).

1.3 Industrial security

Note

Industrial security

Siemens provides products and solutions with industrial security functions that support the secure operation of plants, systems, machines and networks.

In order to protect plants, systems, machines and networks against cyber threats, it is necessary to implement – and continuously maintain – a holistic, state-of-the-art industrial security concept. Siemens products and solutions represent only one component of such a concept.

The customer is responsible for preventing unauthorized access to its plants, systems, machines and networks. Systems, machines and components should only be connected to the company's network or the internet if and to the extent necessary and with appropriate security measures (e.g. use of firewalls and network segmentation) in place.

Additionally, Siemens' guidance on appropriate security measures should be taken into account. For more information about industrial security, please visit:

Industrial security (<http://www.siemens.com/industrialsecurity>).

Siemens' products and solutions undergo continuous development to make them more secure. Siemens expressly recommends that updates are carried out as soon as they become available and that only the current product versions are used. Use of product versions that are no longer supported, and failure to apply latest updates may increase customer's exposure to cyber threats.

To stay informed about product updates, subscribe to the Siemens Industrial Security RSS Feed at: Industrial security (<http://www.siemens.com/industrialsecurity>).

WARNING

Unsafe operating states resulting from software manipulation

Software manipulation (e.g. viruses, trojans, malware or worms) can cause unsafe operating states in your system that may lead to death, serious injury, and property damage.

- Keep the software up to date.
- Incorporate the automation and drive components into a state-of-the-art, integrated industrial security concept for the installation or machine.
- Make sure that you include all installed products into the integrated industrial security concept.
- Protect files stored on exchangeable storage media from malicious software by with suitable protection measures, e.g. virus scanners.

Note

Industrial security Configuration Manual

You can find a Configuration Manual on the topic of industrial security at this address (<https://support.industry.siemens.com/cs/ww/en/view/108862708>).

1.4 Residual risks of power drive systems

When assessing the machine or system-related risk in accordance with the respective local regulations (e.g. EC Machinery Directive), the machine manufacturer or system installer must take into account the following residual risks emanating from the control and drive components of a drive system:

1. Unintentional movements of the driven machine or system components during commissioning, operation, maintenance, and repairs caused by, for example:
 - Hardware and/or software errors in the sensors, control system, actuators and cables and connections
 - Response times of the controller and drive
 - Operation and/or environmental conditions outside the specification
 - Condensation/conductive pollution
 - Parameterization, programming, cabling, and installation errors
 - Use of wireless devices/mobile phones in the immediate vicinity of electronic components
 - External influence/damage
 - X-ray, ionizing radiation and cosmic radiation
2. Unusually high temperatures - including open flames - as well as the emission of light, noise, particles, gases, etc. can occur inside and outside the components under fault conditions caused by, for example:
 - Component malfunctions
 - Software errors
 - Operation and/or environmental conditions outside the specification
 - External influence/damage
3. Hazardous shock voltages caused by, for example:
 - Component malfunctions
 - Influence of electrostatic charging
 - Induction of voltages in moving motors
 - Operation and/or environmental conditions outside the specification
 - Condensation/conductive pollution
 - External influence/damage
4. Electrical, magnetic and electromagnetic fields generated in operation that can pose a risk to people with a pacemaker, implants or metal replacement joints, etc. if they are too close.
5. Release of environmental pollutants or emissions as a result of improper operation of the system and/or failure to dispose of components safely and correctly
6. Influence of network-connected communication systems, e.g. ripple-control transmitters or data communication via the network

For more information about residual risks of the components in a drive system, see the relevant sections in the technical user documentation.

System overview

2.1 The SINAMICS range of drives

Field of application

SINAMICS is the comprehensive family of drives from Siemens designed for machine and plant engineering applications. SINAMICS offers solutions for all drive tasks:

- Simple pump and fan applications in the process industry
- Complex single drives in centrifuges, presses, extruders, elevators, as well as conveyor and transport systems
- Drive line-ups in textile, plastic film, and paper machines as well as in rolling mill plants.
- High-precision servo drives for the manufacture of wind turbines
- Servo drives with a high dynamic performance for machine tools, as well as packaging and printing machines



Figure 2-1 SINAMICS as part of the Siemens modular automation system

Variants

Depending on the application, the SINAMICS range offers the ideal variant for any drive task.

- **SINAMICS V**
From both the hardware perspective as well as the functionality, these converters focus on the essential issues. The result is a high degree of ruggedness with low investment costs.
Operation is directly at the converter without requiring any additional engineering tools. SINAMICS V is especially suitable for applications where no special drive-related know-how is required.
- **SINAMICS G**
In operation, SINAMICS G converters fully leverage their technological strength. Users benefit from a standard but at the same time straightforward operating concept. This minimizes training and service costs. Another impressive feature of the SINAMICS G range is its optimum price-performance ratio.
- **SINAMICS S**
SINAMICS S converters have been specially developed for use in complex machine and plant engineering applications – and to meet the demands of a broad range of motion control tasks. One essential feature is especially: The highest level of standardized engineering.

Platform concept

All SINAMICS versions are based on a platform concept. Common hardware and software components, as well as standardized tools for design, configuration and commissioning tasks, ensure high-level integration across all components. SINAMICS handles a wide variety of drive tasks without system gaps.

The different SINAMICS versions can be easily combined with each other.

Totally Integrated Automation and communication

SINAMICS is an integral component of Siemens Totally Integrated Automation. The integrated and seamless SINAMICS system covering engineering, data management, and communication at the automation level ensures solutions with low associated costs in conjunction with the SIMATIC, SIMOTION, and SINUMERIK control systems.

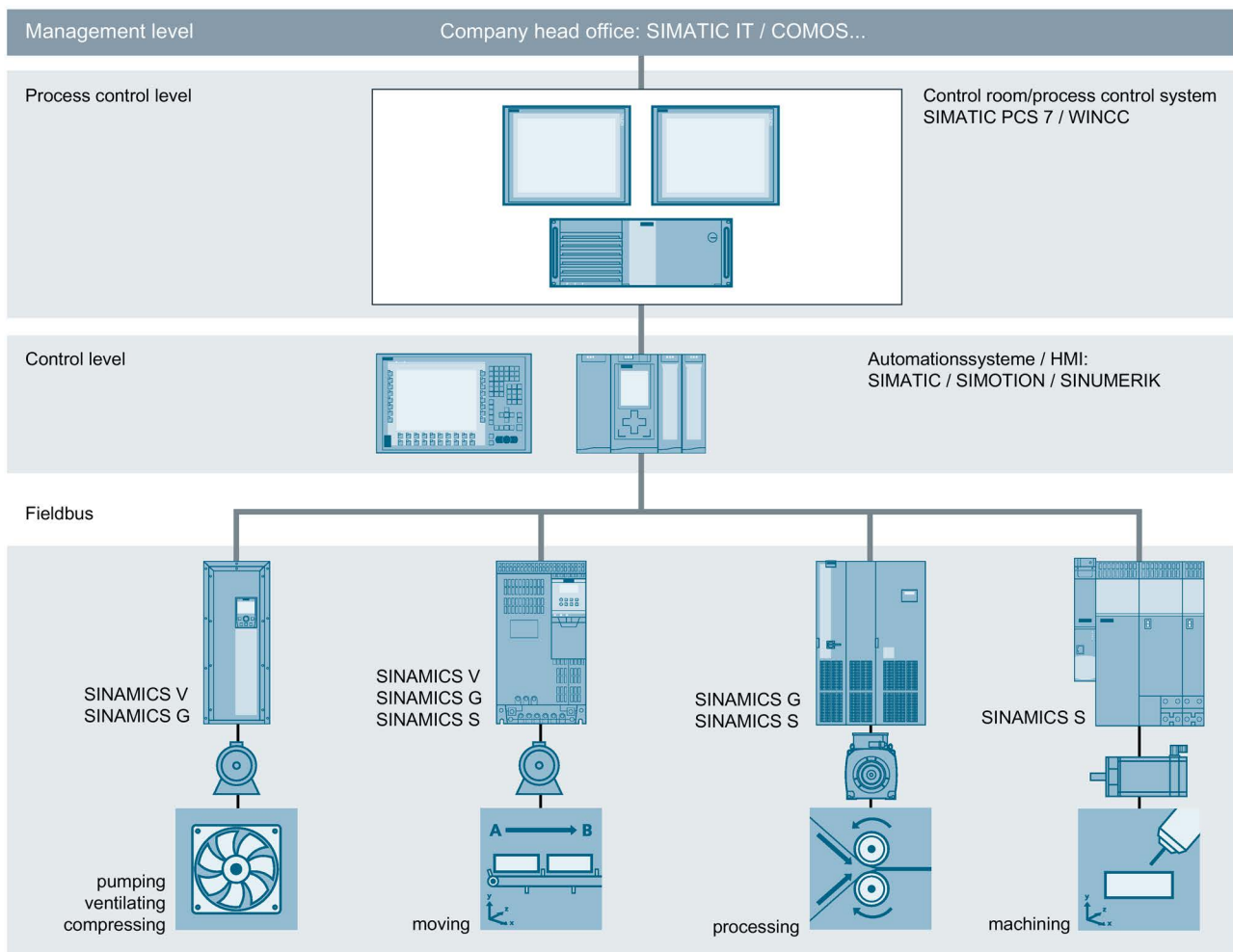

Figure 2-2 SINAMICS in the automation environment

Depending on the application, the appropriate converter can be selected and incorporated in the automation concept. With this in mind, the converters are clearly subdivided into their different applications. A wide range of communication options (depending on the drive type) are available for establishing a communication link to the automation system:

- PROFINET
- EtherNet/IP
- PROFIBUS
- AS-interface
- USS
- CANopen
- Modbus RTU
- BacNet MS/TP

Quality management according to DIN EN ISO 9001

SINAMICS is able to meet the highest requirements in terms of quality. Comprehensive quality assurance measures in all development and production processes ensure a consistently high level of quality.

It goes without saying that our quality management system is certified by an independent authority in accordance with EN ISO 9001.

Universal applications

SINAMICS meets the requirements of relevant international standards and regulations – from the EN European standards through IEC to UL and cULus.

System properties

The SINAMICS range is characterized by the following system properties:

- Standard and seamless functionality based on a platform concept
- Standardized engineering
- High degree of flexibility and combination capability
- Wide range of power ratings
- Designed for global use
- SINAMICS Safety Integrated
- Higher economic efficiency and effectiveness
- High energy efficiency
- Wide range of coupling options to higher-level control systems
- Totally Integrated Automation

2.2 SINAMICS S120 drive system

Modular system for sophisticated drive tasks

SINAMICS S120 solves demanding drive tasks for a wide range of industrial applications and is, therefore, designed as a modular system. Users can choose from many different harmonized components and functions to create a solution that best meets their requirements. SIZER, a high-performance engineering tool, makes it easier to choose and determine the optimum drive configuration. SINAMICS S120 is enhanced by a wide range of motors. Whether synchronous or induction, all motor types are supported by SINAMICS S120.

Particularly suitable for multi-axis applications

Coordinated drives that carry out drive tasks together are used in many mechanical and plant engineering applications, including running gears in gantry cranes, stretching systems in the textile industry, or paper machines and rolling mills. These require drives with a connected DC link which allows cost-saving energy balancing between braking and driving axes.

SINAMICS S120 features Line Modules (infeed modules) and Motor Modules (inverter modules) covering a wide power range which, having been designed for seamless integration, pave the way for compact multi-axis drive configurations.

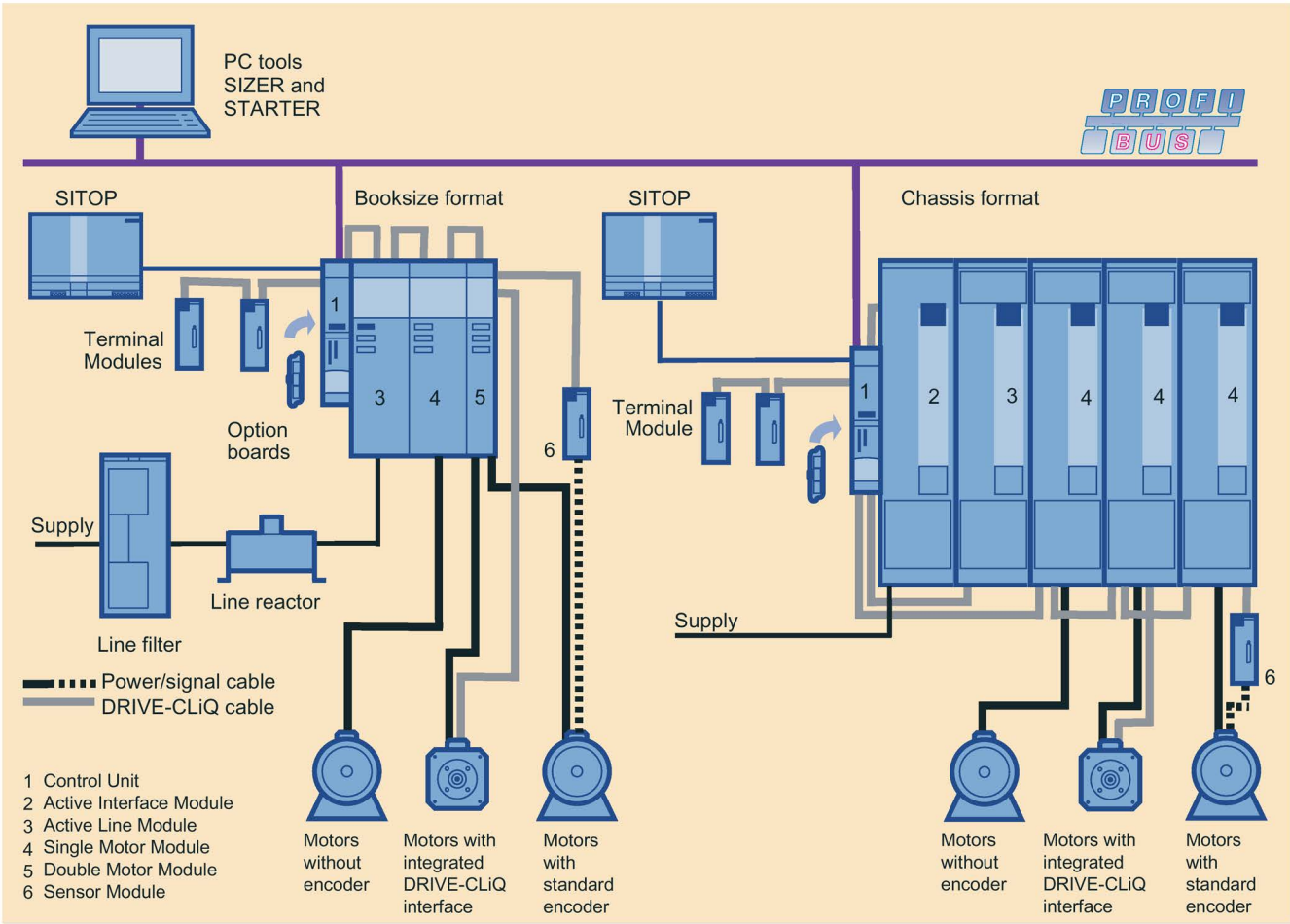

Figure 2-3 SINAMICS S120 system overview

New system architecture with a central Control Unit

Electronically coordinated individual drives work together to perform your drive tasks. Higher-level controllers operate the drives to achieve the required coordinated movement. This requires cyclic data exchange between the controller and all the drives. This exchange usually took place via a field bus, which required a great deal of time and effort for installation and configuration. SINAMICS S120 takes a different approach. A central Control Unit controls the drive for all connected axes and also establishes the technological links between the drives and/or axes. Since all the required data is stored in the central Control Unit, it does not need to be transferred. Inter-axis connections can be established within a Control Unit and easily configured in the STARTER commissioning tool using a mouse.

The SINAMICS S120 Control Unit solves basic technological tasks autonomously. For complex numerical or motion-control tasks, high-performance SIMOTION D modules are used instead.

DRIVE-CLiQ – the digital interface between all components

All SINAMICS S120 components, including the motors and encoders, are interconnected by a shared serial interface called DRIVE-CLiQ. The standardized cables and connectors reduce the variety of different parts and cut storage costs.

Converter boards (Sensor Modules) for converting standard encoder signals to DRIVE-CLiQ are available for third-party motors or retrofit applications.

Electronic rating plates in all components

All SINAMICS S120 components with a DRIVE-CLiQ interface have an electronic rating plate. This electronic rating plate contains all the relevant technical data about that particular component. For motors, for example, this data includes the parameters of the electric equivalent circuit diagram and characteristic values for the built-in motor encoder. The Control Unit records this data automatically via DRIVE-CLiQ so that it does not need to be entered during commissioning or when the equipment is replaced.

In addition to the technical data, the rating plate includes logistical data (manufacturer ID, article number, and globally unique ID). Since this data can be called up electronically on site or remotely, all the components used in a machine can always be individually identified, which helps simplify servicing.

SINAMICS S120 components

The SINAMICS S120 components are primarily used for multi-axis drive tasks.

The following power components are available:

- **Line-side power components**, such as fuses, contactors, line reactors and line filters for switching the power supply and complying with EMC regulations.
- **Line Modules**, which supply power centrally to the DC link.
- **DC-link components** which are used optionally to stabilize the DC-link voltage.
- **Motor Modules**, which act as inverters, receive power from the DC link, and supply the connected motors.
- **Motor-side components**, such as sine-wave filters, motor reactors, and dV/dt filters for reducing the voltage loads on the motor windings.

To carry out the required functions, SINAMICS S120 is equipped with:

- A **Control Unit** that carries out all drive and technological functions across all axes.
- **Additional system components** that enhance functionality and offer different interfaces for encoders and process signals.

SINAMICS S120 components were developed for installation in cabinets. They have the following features and characteristics:

- Easy to handle, simple installation and wiring
- Practical connection system, cable routing according to EMC requirements
- Standardized design, seamless integration.

2.3 Technical specifications

Technical data

Unless specified otherwise, the following technical data is valid for all the following components of the SINAMICS S120 drive system.

Table 2- 1 General technical data

Electrical data	
Line supply voltage	<ul style="list-style-type: none"> • 3 AC 380 V -10% (-15% < 1 min) ... 3 AC 480 V +10% • 3 AC 500 V -10% (-15% < 1 min) ... 3 AC 690 V +10%
Line frequency	47 ... 63 Hz
Output voltage	0 to line connection voltage, depending on the type of infeed. With an Active Line Module, it is also possible to achieve a higher output voltage.
Output frequency	Vector control: 0 ... 550 Hz ¹⁾ Servo control: 0 ... 550 Hz ¹⁾ U/f control: 0 ... 550 Hz ¹⁾
Electronic power supply	24 V DC (20.4 V ... 28.8 V) implemented as PELV circuit according to EN 61800-5-1 Ground = Negative polarity grounded via the electronics
Rated short-circuit current according to IEC, in conjunction with the specified fuses and circuit breakers	<ul style="list-style-type: none"> • 1.1 ... 447 kW: 65 kA • 448 ... 671 kW: 84 kA • 672 ... 1193 kW: 170 kA • >1194 kW: 200 kA
Rated short-circuit current SCCR (Short-Circuit Current Rating) according to UL508C (up to 600 V), in conjunction with the specified fuses or circuit breakers	<ul style="list-style-type: none"> • 1.1 ... 447 kW: 65 kA • 448 ... 671 kW: 84 kA • 672 ... 1193 kW: 170 kA • >1194 kW: 200 kA
Frequency with which the DC link is pre-charged	Max. 1 precharge every 3 minutes
Interference suppression	
<ul style="list-style-type: none"> • Standard • With line filter 	<ul style="list-style-type: none"> • Category C3 (second environment) according to EN 61800-3 • Category C2 (first environment) according to EN 61800-3
Overvoltage category	Class III according to EN 61800-5-1
Mechanical data	
Vibratory load <ul style="list-style-type: none"> • Transport ²⁾ • Operation 	<ul style="list-style-type: none"> • EN 60721-3-2, class 2M2 • Test values according to EN 60068-2-6 test Fc: <ul style="list-style-type: none"> – 10 ... 58 Hz: Constant deflection = 0.075 mm – 58 ... 150 Hz: Constant acceleration = 9.81 m/s² (1 g)
Shock stressing <ul style="list-style-type: none"> • Transport ²⁾ • Operation 	<ul style="list-style-type: none"> • EN 60721-3-2, class 2M2 • Test values according to EN 60068-2-27 test Ea: 98 m/s² (10 g) / 20 ms

Ambient conditions	
Degree of protection	IP00 or IP20 according to EN 60529
Protection class	Class I (with protective conductor system) and class III (PELV) according to EN 61800-5-1
Shock protection	EN 50274 and DGUV regulation 3 when used for the intended purpose
Permissible ambient and coolant temperature (air) during operation for line-side components, Line Modules and Motor Modules	0 ... +40 °C without derating, >40 ... +55 °C see derating characteristics
Permissible ambient and/or coolant temperature (air) when operating Motor Modules Chassis-2	-10 ... +35 °C for installation altitudes ≤ 2000 m above sea level without derating -10 ... +45 °C for installation altitudes ≤ 1000 m above sea level without derating >45 ... +60 °C for installation altitudes ≤ 2000 m above sea level, see the derating characteristics
Permissible ambient and coolant temperature (air) during operation for DC-link and motor-side power components	0 ... +55 °C up to 2000 m above sea level
Cooling method according to EN 60146-1-1	<ul style="list-style-type: none"> • Active Interface Modules, Basic Line Modules, Smart Line Modules, Active Line Modules, Motor Modules: AF <ul style="list-style-type: none"> – A: Air cooling – F: Forced cooling, drive unit inside the device • Line reactors, sine-wave filters, motor reactors, dV/dt filters with Voltage Peak Limiter: AN <ul style="list-style-type: none"> – A: Air cooling – N : Natural cooling (convection)
Climatic ambient conditions	
<ul style="list-style-type: none"> • Storage ²⁾ • Transport ²⁾ • Operation 	<ul style="list-style-type: none"> • Class 1K4 acc. to EN 60721-3-1, temperature -25 ... +55 °C • Class 2K4 according to EN 60721-3-2, temperature -40 ... +70 °C, max. air humidity 95% at +40 °C • Better than Class 3K3 according to EN 60721-3-3, relative humidity: 5 ... 95% (no condensation) Oil mist, salt mist, ice formation, condensation, dripping water, spraying water, splashing water and water jets are not permitted
Environmental class / harmful chemical substances	
<ul style="list-style-type: none"> • Storage ²⁾ • Transport ²⁾ • Operation 	<ul style="list-style-type: none"> • Class 1C2 acc. to EN 60721-3-1 • Class 2C2 acc. to EN 60721-3-2 • Class 3C2 acc. to EN 60721-3-3
Environmental class /mechanically active substances	
<ul style="list-style-type: none"> • Storage ²⁾ • Transport ²⁾ • Operation 	<ul style="list-style-type: none"> • Class 1S1 according to EN 60721-3-1 • Class 2S1 according to EN 60721-3-2 • Class 3S1 according to EN 60721-3-3
Organic/biological influences	
<ul style="list-style-type: none"> • Storage ²⁾ • Transport ²⁾ • Operation 	<ul style="list-style-type: none"> • Class 1B1 acc. to EN 60721-3-1 • Class 2B1 acc. to EN 60721-3-2 • Class 3B1 acc. to EN 60721-3-3

2.3 Technical specifications

Degree of pollution	2 according to EN 61800-5-1 The devices may be operated only in environments with degree of pollution 2 and without condensation. On control cabinets with forced air cooling, foreign particles must be filtered out of the inflow air through filter mats. To prevent condensation, the devices can be warmed constantly by heaters.
<p>The Safety Integrated safety function:</p> <p>The components must be protected against conductive contamination (e.g. by installing them in a cabinet with degree of protection IP54B according to EN 60529). Provided that conducted interference can be prevented at the installation site, the degree of protection for the cabinet can be decreased accordingly.</p>	
Installation altitude	<ul style="list-style-type: none"> • > 2000 m above sea level without derating • > 2000 ... 4000 m above sea level, see derating characteristics
Certificates	
Conformity	<ul style="list-style-type: none"> - EMC Directive No. 2014/30/EU - Low-Voltage Directive No. 2014/35/EU - Machinery Directive No. 2006/42/EC for functional safety
Standards	EN 61800-5-1, EN 60204-1, EN 61800-3, EN 60146-1-1
Approvals (only up to 3 AC 600 V)	cULus (File Nos.: E192450, E214113 and E253831) being prepared: 6SL3321-1TE41-2AA0

- 1) Depending on the system configuration, higher output frequencies are possible.
- 2) In transport packaging

2.4 Derating factors as a function of installation altitude and ambient temperature

Chassis format units

At installation altitudes > 2000 m above sea level, it must be taken into account that the air pressure, and therefore air density, decreases as the height increases. This reduces the cooling effect as well as the insulating strength of the air.

As a result of the lower cooling effect, on the one hand, the ambient temperature must be reduced, and on the other hand, the power loss in the chassis unit must also be reduced by decreasing the output current; whereby ambient temperatures less than 40 °C can be factored in as countermeasure for compensation.

The following table shows the permissible output currents as a function of installation altitude and ambient temperature (the permissible compensation between installation altitude and ambient temperatures of < 40 °C – inlet air temperature at the air inlet of the chassis unit – is taken into account in the specified values).

The values apply under the precondition that a cooling air flow through the units as stated in the technical data is ensured.

As a further measure at installation altitudes of 2000 m and 5000 m, the use of an isolating transformer is required to reduce transient overvoltages according to EN 61800-5-1.

Chassis units and the associated system components are rated for an ambient temperature of 40 °C and installation altitudes up to 2000 m above sea level.

At ambient temperatures > 40 °C, the output current must be reduced. Ambient temperatures above 55 °C are not permissible.

Table 2- 2 Current derating for chassis units as a function of ambient temperature (air intake temperature at the air inlet of the chassis unit) and installation altitude

Installation altitude above sea level in m	Current derating factor (in % of rated current)							
	at an ambient temperature (air intake temperature) of							
	20 °C	25 °C	30 °C	35 °C	40 °C	45 °C	50 °C	55 °C
0 ... 2000	100%	100%	100%	100%	100%	93.3%	86.7%	80.0%
... 2500	100%	100%	100%	100%	96.3%			
... 3000	100%	100%	100%	98.7%				
... 3500	100%	100%	100%					
... 4000	100%	100%	96.3%					
... 4500	100%	97.5%						
... 5000	98.2%							

Built-in devices, Chassis-2 format

At installation altitudes > 2000 m above sea level, it must be taken into account that the air pressure, and therefore air density, decreases as the height increases. As a consequence, in addition to the reduced cooling effect, the insulating capability of the air is also reduced.

As a result of the lower cooling effect, on one hand, the ambient temperature must be reduced, and on the other hand, the power loss in the chassis unit must also be reduced by decreasing the output current; whereby ambient temperatures less than 35 °C can be factored in as countermeasure for compensation.

The following table shows the permissible output currents as a function of installation altitude and ambient temperature (the permissible compensation between installation altitude and ambient temperatures of < 35 °C – inlet air temperature at the air inlet of the chassis unit – is taken into account in the specified values).

The values apply under the precondition that a cooling air flow through the devices is ensured as specified in the technical specifications.

As a further measure at installation altitudes of 2000 m and 5000 m, the use of an isolating transformer is required to reduce transient overvoltages in accordance with EN 61800-5-1.

Built-in devices in the Chassis-2 format and the associated system components are rated for an ambient temperature of 45 °C and installation altitudes up to 1000 m above sea level.

The output current must be reduced for ambient temperatures > 45 °C. Ambient temperatures above 60 °C are not permissible.

Table 2-3 Current derating for built-in units Chassis-2 as a function of ambient temperature (air intake temperature at the air inlet of the built-in devices) and installation altitude

Installation altitude above sea level in m	Current derating factor (in % of rated current) at an ambient temperature (air inlet temperature) of								
	20 °C	25 °C	30 °C	35 °C	40 °C	45 °C	50 °C	55 °C	60 °C
0 ... 1000	100%	100%	100%	100%	100%	100%	83%	69%	54%
... 1500	100%	100%	100%	100%	100%	98%	81%	67%	52%
... 2000	100%	100%	100%	100%	100%	93%	78%	65%	50%
... 2500	100%	100%	100%	100%	96%				
... 3000	100%	100%	100%	99%					
... 3500	100%	100%	100%						
... 4000	100%	100%	96%						
... 4500	100%	97%							
... 5000	98%								

2.5 Standards

Note

Information on the listed standards

The standards listed in the table below are non-binding and do not in any way claim to be complete. The standards listed do not represent a guaranteed property of the product.

Only the statements made in the Declaration of Conformity shall be deemed binding.

Table 2- 4 Fundamental, application-relevant standards in succession: EN, IEC/ISO, DIN, VDE

Standards*	Title
EN ISO 3744	Acoustics – Determination of sound power levels and sound energy levels of noise sources using sound pressure – Engineering methods for an essentially free acoustic field over a reflecting plane
EN 1037 ISO 14118 DIN EN 1037	Safety of machinery; avoiding unexpected starting
EN ISO 9001 ISO 9001 DIN EN ISO 9001	Quality management systems – Requirements
EN ISO 12100-x ISO 12100-x DIN EN ISO 12100-x	Safety of Machinery; General Design Guidelines; Part 1: Basic Terminology, Methodology Part 2: Technical Principles and Specifications
EN ISO 13849-x ISO 13849-x DIN EN ISO 13849-x	Safety of Machinery; Safety-Related Parts of Control Systems; Part 1: General Basic Design Principles Part 2: Validation
EN ISO 14121-1 ISO 14121-1 DIN EN ISO 14121-1	Safety of Machinery – Risk Assessment; Part 1: Guidelines
EN 55011 CISPR 11 DIN EN 55011 VDE 0875-11	Industrial, scientific and medical high-frequency devices (ISM devices) - Radio interference – Limit values and measuring techniques
EN 60146-1-1 IEC 60146-1-1 DIN EN 60146-1-1 VDE 0558-11	Semiconductor converters; general requirements and line-commutated converters; Part 1-1: Defining the basic requirements
EN 60204-1 IEC 60204-1 DIN EN 60204-1 VDE 0113-1	Electrical equipment of machines; Part 1: General definitions
EN 60228 IEC 60228 DIN EN 60228 VDE0295	Conductors for cables and insulated leads

2.5 Standards

Standards*	Title
EN 60269-1 IEC 60269-1 DIN EN 60269-1 VDE 0636-1	Low-voltage fuses; Part 1: General requirements
IEC 60287-1 to -3	Cables – Calculation of the current carrying capacity Part 1: Current carrying capacity equations (100% load factor) and calculating the losses Part 2: Thermal resistance Part 3: Main sections for operating conditions
HD 60364-x-x IEC 60364-x-x DIN VDE 0100-x-x VDE 0100-x-x	Erection of power installations with nominal voltages up to 1000 V; Part 200: Definitions Part 410: Protection for safety, protection against electric shock Part 420: Protection for safety, protection against thermal effects Part 430: Protection of cables and conductors for overcurrent Part 450: Protection for safety, protection against undervoltage Part 470: Protection for safety; use of protection for safety Part 5xx: Selecting and erecting electrical equipment Part 520: Cables, conductors, busbars Part 540: Grounding, protective conductor, potential bonding conductor Part 560: Electrical equipment for safety purposes
EN 60439 IEC 60439 DIN EN 60439 VDE 0660-500	Low-voltage switchgear assemblies; Part 1: Type-tested and partially type-tested assemblies
EN 60529 IEC 60529 DIN EN 60529 VDE 0470-1	Degrees of protection provided by enclosures (IP code)
EN 60721-3-x IEC 60721-3-x DIN EN 60721-3-x	Classification of environmental conditions Part 3-0: Classification of environmental parameters and their severities; Introduction Part 3-1: Classification of environmental parameters and their severities; Long-term storage Part 3-2: Classification of environmental parameters and their severities; Transport Part 3-3: Classification of environmental parameters and their severities; stationary use, weather protected
EN 60947-x-x IEC 60947 -x-x DIN EN 60947-x-x VDE 0660-x	Low-voltage switchgear
EN 61000-6-x IEC 61000-6-x DIN EN 61000-6-x VDE 0839-6-x	Electromagnetic compatibility (EMC) Part 6-1: Generic standard; Immunity for residential, commercial and light-industrial environments Part 6-2: Generic standards; Immunity for industrial environments Part 6-3: Generic standards; Generic standard emission for residential, commercial and light-industrial environments Part 6-4: Generic standards; Generic standard noise emission for industrial environments
EN 61140 IEC 61140 DIN EN 61140 VDE 0140-1	Protection against electric shock; Common aspects for installation and equipment
EN 61800-2 IEC 61800-2 DIN EN 61800-2 VDE 0160-102	Adjustable-speed electrical power drive systems; Part 2: General requirements – Rating specifications for low-voltage adjustable frequency a.c. power drive systems

Standards*	Title
EN 61800-3 IEC 61800-3 DIN EN 61800-3 VDE 0160-103	Adjustable-speed electrical power drive systems; Part 3: EMC requirements and specific test methods
EN 61800-5-x IEC 61800-5-x DIN EN 61800-5-x VDE 0160-105-x	Adjustable-speed electrical power drive systems; Part 5: Safety requirements; Main section 1: Electrical, thermal and energy requirements Main section 2: Functional safety requirements
EN 62061 IEC 62061 DIN EN 62061 VDE 0113-50	Safety of machinery; Functional safety of safety-related electrical, electronic and programmable electronic control systems
UL 50 CSA C22.2 No. 94.1	Enclosures for Electrical Equipment
UL 508 CSA C22.2 No. 142	Industrial Control Equipment Process Control Equipment
UL 508C CSA C22.2 No. 14	Power Conversion Equipment Industrial Control Equipment
UL61800-5-1 CSA 22.2 No. 274-13	Standard for Adjustable Speed Electrical Power Drive Systems – Part 5-1: Safety requirements – Electrical, thermal and energy

* The technical requirements in the standards listed are not necessarily identical.

2.6 Basic structure of a drive system with SINAMICS S120

2.6.1 Structure of a drive system with SINAMICS S120 and regulated infeed

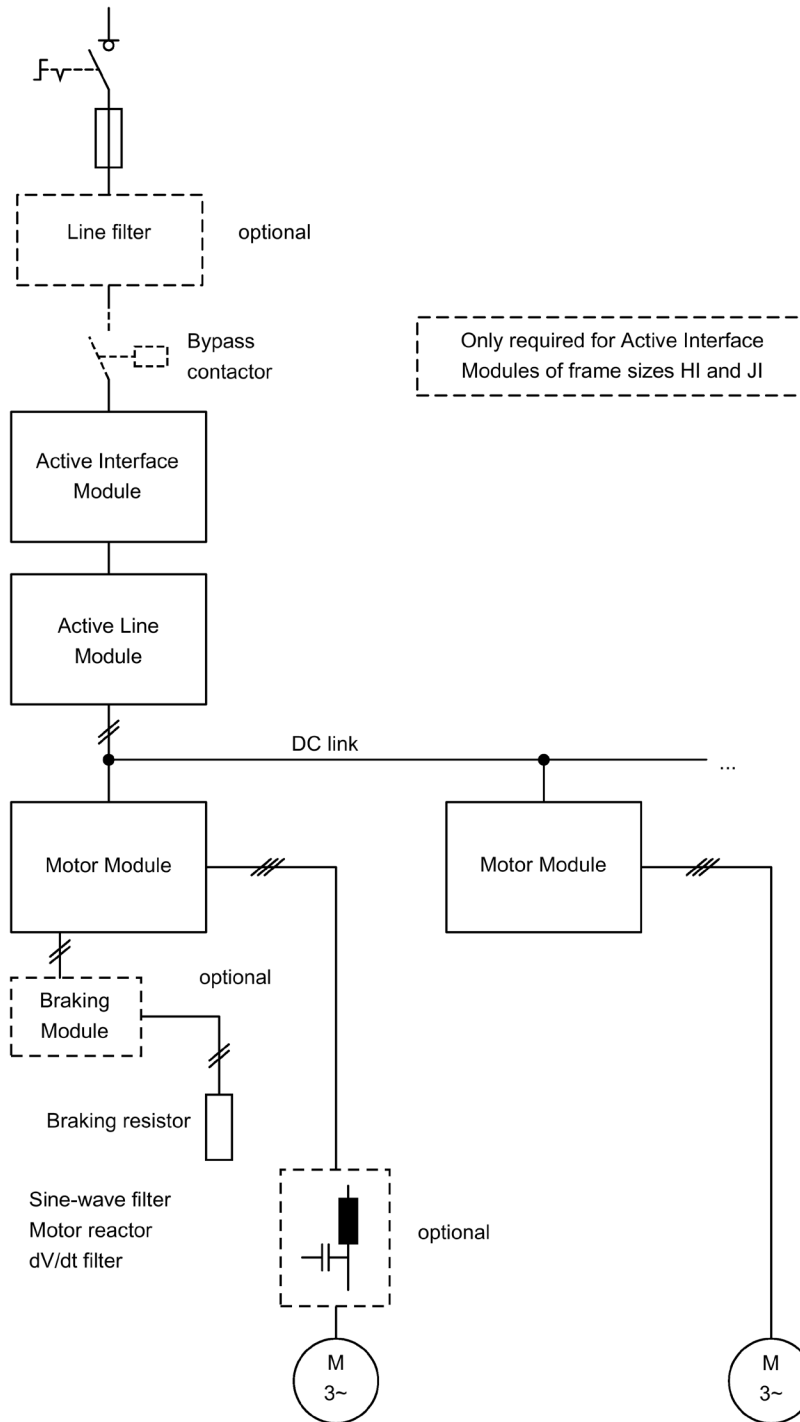

Figure 2-4 Basic structure of a drive system with SINAMICS S120 and regulated infeed

2.6.2 Structure of a drive system with SINAMICS S120 and uncontrolled infeed/regenerative feedback unit

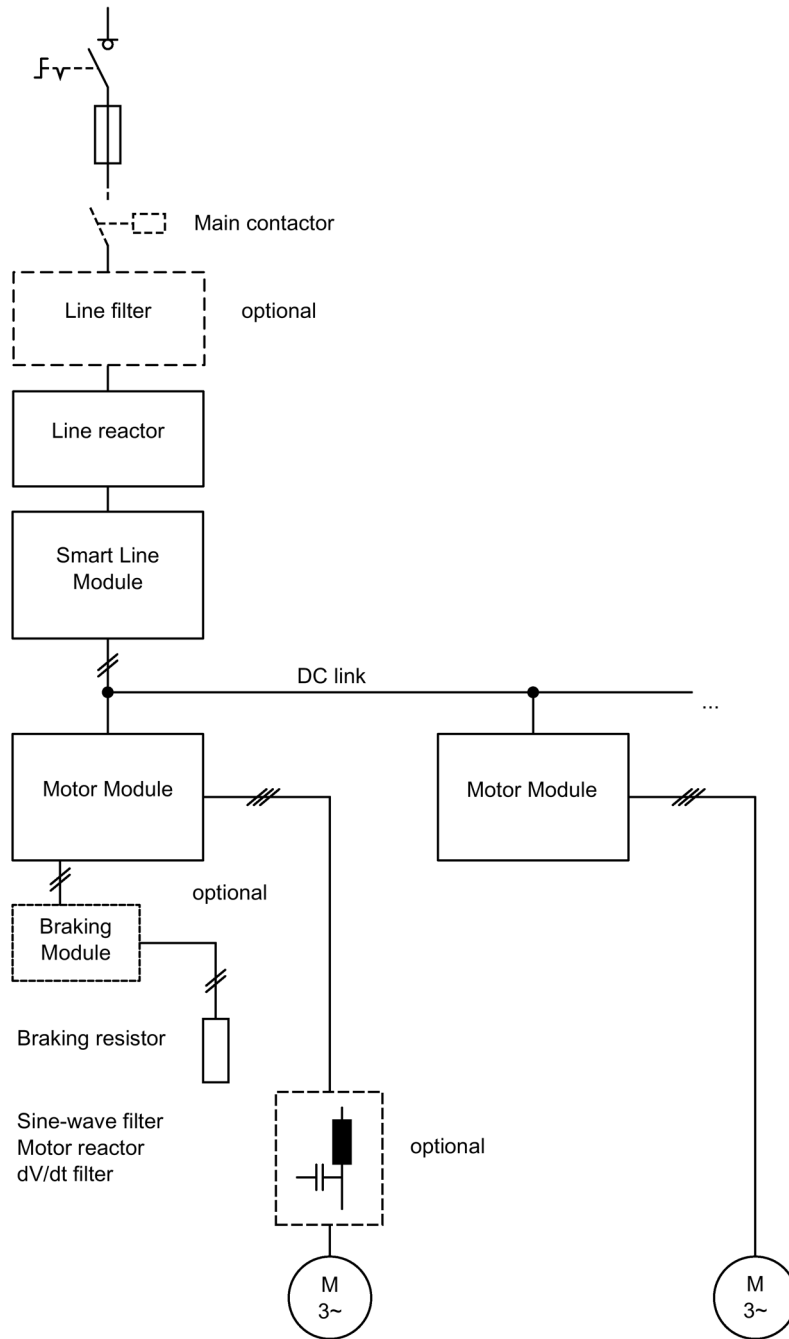

Figure 2-5 Basic structure of a drive system with SINAMICS S120 and uncontrolled infeed/regenerative feedback

2.6.3 Structure of a drive system with SINAMICS S120 and unregulated infeed

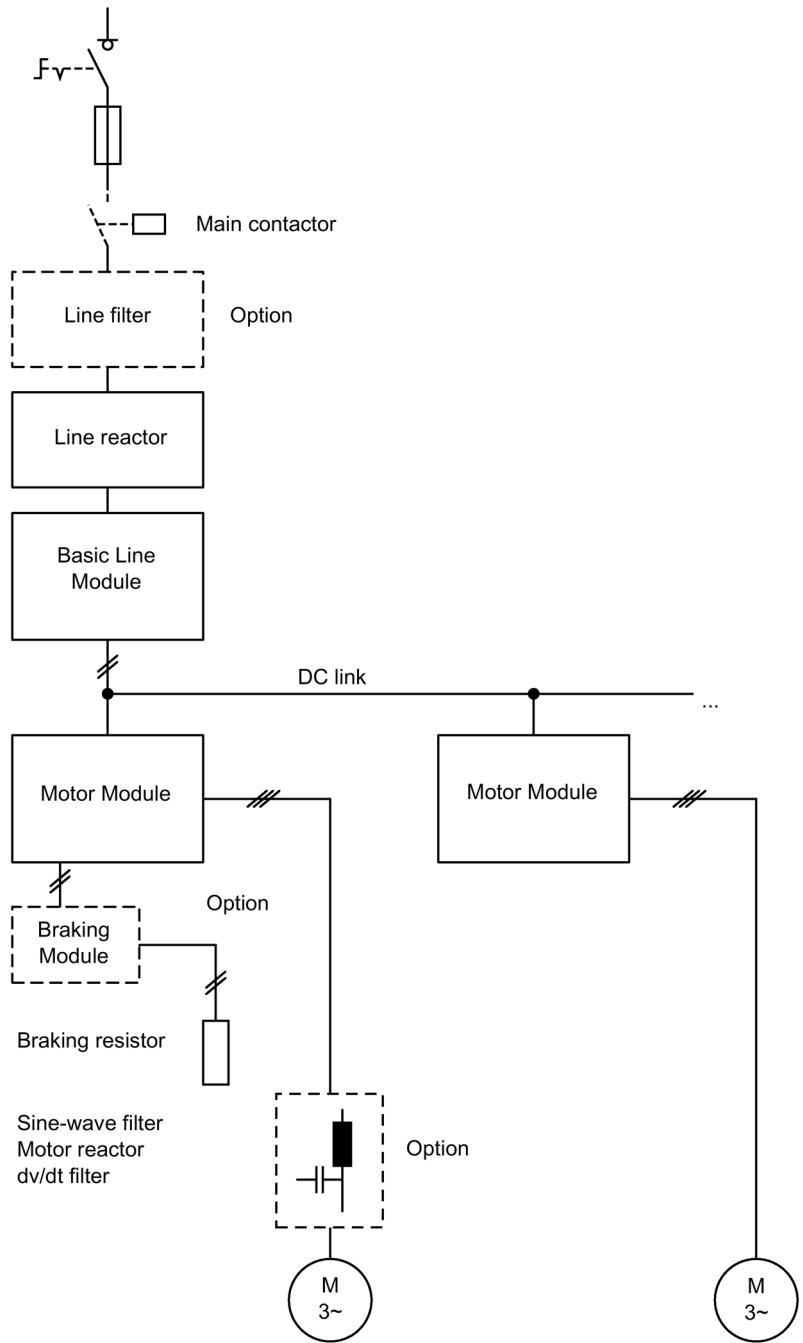

Figure 2-6 Basic structure of a drive system with SINAMICS S120 and unregulated infeed

Line-side power components

3.1 General

Line-side power components are used to protect the connected components against transient or continuous overvoltages and ensure that prescribed limit values are adhered to.

3.2 Line filters for Basic Line Modules

3.2.1 Description

The line filters limit the conducted interference emitted by the Power Modules to permissible values.

To reduce emissions, the Line Modules are equipped as standard with a line filter in accordance with the limit values defined in category C3 (second environment). The additional line filters described here can be fitted for use in the first environment (category C2).

In conjunction with line reactors, line filters limit the conducted interference emitted by the Power Modules to the limit values defined in product standard EN 61800-3. Provided that the system has been set up in accordance with the EMC installation guidelines, the limit values at the installation location will be in accordance with the requirements for the first environment.

The line filters are suitable for TN and TT supply systems grounded at the neutral point.

Table 3- 1 Assignment of line filter and Basic Line Module

Basic Line Module	Rated power of the Basic Line Module	Suitable line filter
Line voltage 380 – 480 V 3 AC		
6SL3330-1TE34-2AA3	200 kW	6SL3000-0BE34-4AA0
6SL3330-1TE35-3AA3	250 kW	6SL3000-0BE36-0AA0
6SL3330-1TE38-2AA3	400 kW	6SL3000-0BE41-2AA0
6SL3330-1TE41-2AA3	560 kW	6SL3000-0BE41-2AA0
6SL3330-1TE41-5AA3	710 kW	6SL3000-0BE41-6AA0 ¹⁾
6SL3330-1TE41-5AA3	710 kW	6SL3760-0MR00-0AA0 ²⁾
6SL3330-1TE41-8AA3	900 kW	6SL3000-0BE41-6AA0
Line voltage 500 – 690 V 3 AC		
6SL3330-1TG33-3AA3	250 kW	6SL3000-0BG34-4AA0
6SL3330-1TG34-3AA3	355 kW	6SL3000-0BG34-4AA0
6SL3330-1TG36-8AA3	560 kW	6SL3000-0BG36-0AA0
6SL3330-1TG41-1AA3	900 kW	6SL3000-0BG41-2AA0
6SL3330-1TG41-4AA3	1100 kW	6SL3000-0BG41-2AA0
6SL3330-1TG41-8AA3	1500 kW	6SL3000-0BG41-6AA0

¹⁾ The 6SL3000-0BE41-6AA0 line filter can be used if a Motor Module Chassis-2 is not connected to the DC link.

²⁾ The 6SL3760-0MR00-0AA0 line filter must be used if a Motor Module Chassis-2 is connected to the DC link.

3.2.2 Safety information

 WARNING
Not observing fundamental safety instructions and residual risks
Not observing fundamental safety instructions and residual risks listed in Chapter 1 can result in accidents with severe injuries or death.
<ul style="list-style-type: none"> • Comply with the fundamental safety instructions. • When assessing the risk, take into account remaining risks.

 CAUTION
Burns resulting from high surface temperature
The line filter can become very hot. You can get seriously burnt when touching the surface.
<ul style="list-style-type: none"> • Mount the line filter so that contact is not possible. If this is not possible, attach a clearly visible and understandable warning notice at hazardous positions. • To prevent adjacent components from suffering damage due to these high temperatures, maintain a clearance of 100 mm on all sides of the line filter.

NOTICE**Line filter damage by connecting to impermissible line supplies**

The line filters are only suitable for direct connection to TN or TT systems with grounded neutral point. Line filters are designed for connection to systems with a continuous level to voltage harmonics in accordance with EN 61000-2-4, Class 3. Connection of the line filter to other line systems may result in damage.

- Only connect the line filter to TN or TT systems with grounded neutral point and a continuous level of voltage harmonics in accordance with EN 61000-2-4, Class 3.

NOTICE**Line filter damage due to interchanged connections**

The line filter will be damaged if the input and output connections are interchanged.

- Connect the incoming line cable to LINE/NETZ L1, L2, L3.
- Connect the outgoing cable to the line reactor to LOAD/LAST L1', L2', L3'.

 **WARNING****Fire due to inadequate ventilation clearances**

Inadequate ventilation clearances can cause overheating of components with subsequent fire and smoke. This can cause serious injury or even death. This can also result in increased failures and shorter service lives for devices/systems.

- For this reason, maintain the 100 mm clearances above and below the line filter.

 **WARNING****High leakage currents when the protective conductor in the line feeder cable is interrupted**

The drive components conduct a high leakage current via the protective conductor. Touching conductive parts when the protective conductor is interrupted can result in death or serious injury.

- Ensure that the external protective conductor satisfies at least one of the following conditions:
 - It has been installed so that it is protected against mechanical damage. ¹⁾
 - For an individual core, it has a cross-section of at least 10 mm² Cu.
 - If it is a conductor of a multi-conductor cable, it has a cross-section of at least 2.5 mm² Cu.
 - It has a second protective conductor in parallel with the same cross-section.
 - It complies with the local regulations for equipment with increased leakage current.
- ¹⁾ Cables laid within control cabinets or closed machine housings are considered to be adequately protected from mechanical damage.

 **CAUTION**

Overheating when the total length of the power cables is exceeded

Overheating of the line filter and therefore overheating and fire can result when the total length of the motor cables is exceeded.

- Ensure that the total length of the motor cables does not exceed 100 m.

NOTICE

Damage to additional loads as a result of undesirable line harmonics

Line harmonics can occur if line filters that differ from those listed in this Manual are used. These can disturb or damage other loads connected to the line supply.

- Only use line filters that are listed in this Manual.

NOTICE

Damage to components by incorrectly connecting the line filter

When incorrectly connecting the line filter, these components can be destroyed or damaged.

- Only connect the Line Module to the SINAMICS line filter via the associated line reactor.
- Connect additional loads upstream of the SINAMICS line filter (if required, via a separate line filter).

Note

Disconnect the line filter for a high-voltage test

If a high-voltage test is conducted with alternating voltage in the system, the existing line filters must be disconnected in order to obtain accurate measurements.

If a high-voltage test is carried out with DC, the connection clip to the basic interference suppression module in the Basic Line Module must also be removed, refer to Chapter "Electrical connection" (Page 114).

3.2.3 Dimension drawing

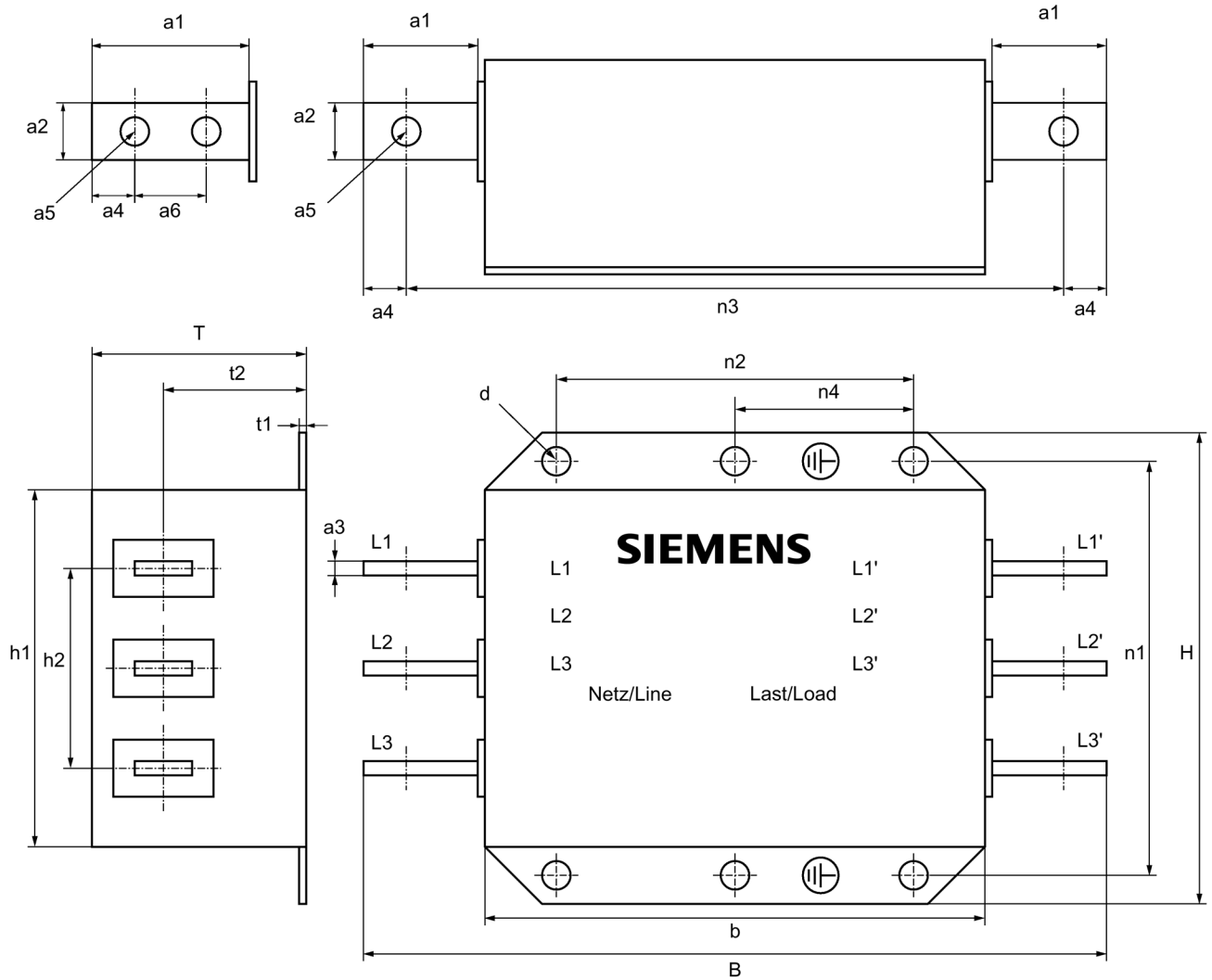

Figure 3-1 Dimension drawing of line filters for Basic Line Modules

3.2 Line filters for Basic Line Modules

Table 3- 2 Dimensions of line filters for Basic Line Modules (all data in mm)

	6SL3000-0BE34-4AA0 6SL3000-0BG34-4AA0	6SL3000-0BE36-0AA0 6SL3000-0BG36-0AA0	6SL3000-0BE41-2AA0 6SL3000-0BG41-2AA0	6SL3000-0BE41-6AA0 6SL3000-0BG41-6AA0	6SL3760-0MR00-0AA0
W	360	400	425	505	425
H	240	265	265	265	265
D	116	140	145	145	148
a1	40	40	50	90	49.5
a2	25	25	50	50	50
a3	5	8	10	15	10
a4	15	15	20	20	20
a5	11	11	14	14	14
a6	-	-	-	40	-
b	270	310	315	315	315
h1	200	215	215	215	215
h2	100	120	142	142	142
t1	2	3	2.5	2.5	2.5
t2	78.2	90	91	91	94
n1 ¹⁾	220	240	240	240	240
n2 ¹⁾	210	250	255	255	255
n3	330	370	385	465	385
n4	-	125	127.5	127.5	127.5
d	9	12	12	12	12

¹⁾ Lengths n1 and n2 correspond to the distance between holes

3.2.4 Technical data

Table 3- 3 Technical data of line filters for Basic Line Modules, 3 AC 380 ... 480 V, Part I

Article number	6SL3000-	OBE34-4AA0	OBE36-0AA0	OBE41-2AA0	OBE41-6AA0
Suitable for Basic Line Module	6SL3330-	1TE34-2AA3	1TE35-3AA3	1TE38-2AA3 1TE41-2AA3	1TE41-5AA3 ¹⁾ 1TE41-8AA3
Rated power of the Basic Line Module	kW	200	250	400 560	710 900
Rated voltage	V	3 AC 380 -10% (-15% < 1 min) ... 3 AC 480 +10%			
Rated current	A	440	600	1200	1600
Power loss	kW	0.047	0.053	0.119	0.153
Line supply/load connection L1, L2, L3/L1', L2', L3'		M10 connecting lugs	M10 connecting lugs	M12 connecting lugs	M12 connecting lugs
PE connection		M8	M10	M10	M10
Degree of protection		IP00	IP00	IP00	IP00
Dimensions					
Width	mm	360	400	425	505
Height	mm	240	265	265	265
Depth	mm	116	140	145	145
Weight	kg	12.3	19.0	25.8	28.8

¹⁾ The 6SL3000-OBE41-6AA0 line filter can be used upstream of the 6SL33301TE41-5AA3 Basic Line Module if a Motor Module Chassis-2 is not connected to the DC link.

Table 3- 4 Technical data of line filters for Basic Line Modules, 3 AC 380 ... 480 V, Part II

Article number		6SL3760-0MR00-0AA0			
Suitable for Basic Line Module	6SL3330-	1TE41-5AA3 ¹⁾			
Rated power of the Basic Line Module	kW	710			
Rated voltage	V	3 AC 380 -10% (-15% < 1 min) ... 3 AC 480 +10%			
Rated current	A	1200			
Power loss	kW	0.106			
Line supply/load connection L1, L2, L3, L1', L2', L3'		M12 connecting lugs			
PE connection		M10			
Degree of protection		IP00			
Dimensions					
Width	mm	425			
Height	mm	265			
Depth	mm	145			
Weight	kg	25			

¹⁾ The 6SL3760-0MR00-0AA0 line filter must be used upstream of the 6SL33301TE41-5AA3 Basic Line Module if a Motor Module Chassis-2 is connected to the DC link.

3.2 Line filters for Basic Line Modules

Table 3- 5 Technical data of line filters for Basic Line Modules, 500 ... 690 V 3 AC

Article number	6SL3000-	0BG34-4AA0	0BG36-0AA0	0BG41-2AA0	0BG41-6AA0
Suitable for Basic Line Module	6SL3330-	1TG33-3AA3 1TG34-3AA3	1TG36-8AA3	1TG41-1AA3 1TG41-4AA3	1TG41-8AA3
Rated power of the Basic Line Module	kW	250 355	560	900 1100	1500
Rated voltage	V	3 AC 500 -10% (-15% < 1 min) ... 3 AC 690 +10%			
Rated current	A	440	600	1200	1600
Power loss	kW	0.047	0.053	0.119	0.182
Line supply/load connection L1, L2, L3/L1', L2', L3'		M10 connecting lugs	M10 connecting lugs	M12 connecting lugs	M12 connecting lugs
PE connection		M8	M10	M10	M10
Degree of protection		IP00	IP00	IP00	IP00
Dimensions					
Width	mm	360	400	425	505
Height	mm	240	265	265	265
Depth	mm	116	140	145	145
Weight	kg	12.3	19.0	25.2	28.8

3.3 Line filters for Smart Line Modules and Active Line Modules

3.3.1 Description

The line filters limit the conducted interference emitted by the Power Modules to permissible values.

To reduce emissions, the Line Modules are equipped as standard with a line filter in accordance with the limit values defined in category C3 (second environment). The additional line filters described here can be fitted for use in the first environment (category C2).

In conjunction with line reactors and/or the Active Interface Modules limit the conducted interference emitted by the Power Modules to the limit values defined in product standard EN 61800-3. Provided that the system has been set up in accordance with the EMC installation guidelines, the limit values at the installation location will be in accordance with the requirements for the first environment.

The line filters are suitable for TN and TT supply systems grounded at the neutral point.

3.3.2 Safety information

WARNING

Not observing fundamental safety instructions and residual risks

Not observing fundamental safety instructions and residual risks listed in Chapter 1 can result in accidents with severe injuries or death.

- Comply with the fundamental safety instructions.
- When assessing the risk, take into account remaining risks.

CAUTION

Burns resulting from high surface temperature

The line filter can become very hot. You can get seriously burnt when touching the surface.

- Mount the line filter so that contact is not possible. If this is not possible, attach a clearly visible and understandable warning notice at hazardous positions.
- To prevent adjacent components from suffering damage due to these high temperatures, maintain a clearance of 100 mm on all sides of the line filter.

NOTICE

Line filter damage by connecting to impermissible line supplies

The line filters are only suitable for direct connection to TN or TT systems with grounded neutral point. Line filters are designed for connection to systems with a continuous level to voltage harmonics in accordance with EN 61000-2-4, Class 3. Connection of the line filter to other line systems may result in damage.

- Only connect the line filter to TN or TT systems with grounded neutral point and a continuous level to voltage harmonics in accordance with EN 61000-2-4, Class 3.

NOTICE

Line filter damage due to interchanged connections

The line filter will be damaged if the input and output connections are interchanged.

- Connect the incoming line cable to LINE/NETZ L1, L2, L3.
- Connect the outgoing cable to the line reactor to LOAD/LAST L1', L2', L3'.

 **WARNING**

Fire due to inadequate ventilation clearances

Inadequate ventilation clearances can cause overheating of components with subsequent fire and smoke. This can cause serious injury or even death. This can also result in increased failures and shorter service lives for devices/systems.

- For this reason, maintain the 100 mm clearances above and below the line filter.



 **WARNING**

High leakage currents when the protective conductor in the line feeder cable is interrupted

The drive components conduct a high leakage current via the protective conductor. Touching conductive parts when the protective conductor is interrupted can result in death or serious injury.

- Ensure that the external protective conductor satisfies at least one of the following conditions:
 - It has been installed so that it is protected against mechanical damage. ¹⁾
 - For an individual core, it has a cross-section of at least 10 mm² Cu.
 - If it is a conductor of a multi-conductor cable, it has a cross-section of at least 2.5 mm² Cu.
 - It has a second protective conductor in parallel with the same cross-section.
 - It complies with the local regulations for equipment with increased leakage current.

¹⁾ Cables laid within control cabinets or closed machine housings are considered to be adequately protected against mechanical damage.

⚠ CAUTION**Overheating when the total length of the power cables is exceeded**

Overheating and fire can result when the total length of the motor cables is exceeded.

- Ensure that the total length of the motor cables does not exceed 300 m.

NOTICE**Damage to additional loads as a result of undesirable line harmonics**

Line harmonics can occur if line filters that differ from those listed in this Manual are used. These can disturb or damage other loads connected to the line supply.

- Only use line filters that are listed in this Manual.

NOTICE**Damage to components by incorrectly connecting the line filter**

When incorrectly connecting the line filter, these components can be destroyed or damaged.

- Only connect the Line Module to the SINAMICS line filter via the associated line reactor or the associated Active Interface Module.
- Connect additional loads upstream of the SINAMICS line filter (if required, via a separate line filter).

Note**Disconnect the line filter for a high-voltage test**

If a high-voltage test is conducted with alternating voltage in the system, the existing line filters must be disconnected in order to obtain accurate measurements.

If a high-voltage test is carried out with DC, the connection clip to the basic interference suppression module must also be removed in the Smart Line Module (see Chapter "Electrical connection" (Page 148)) or in the Active Interface Module (see Chapter "Electrical connection" (Page 87)).

3.3.3 Dimension drawing

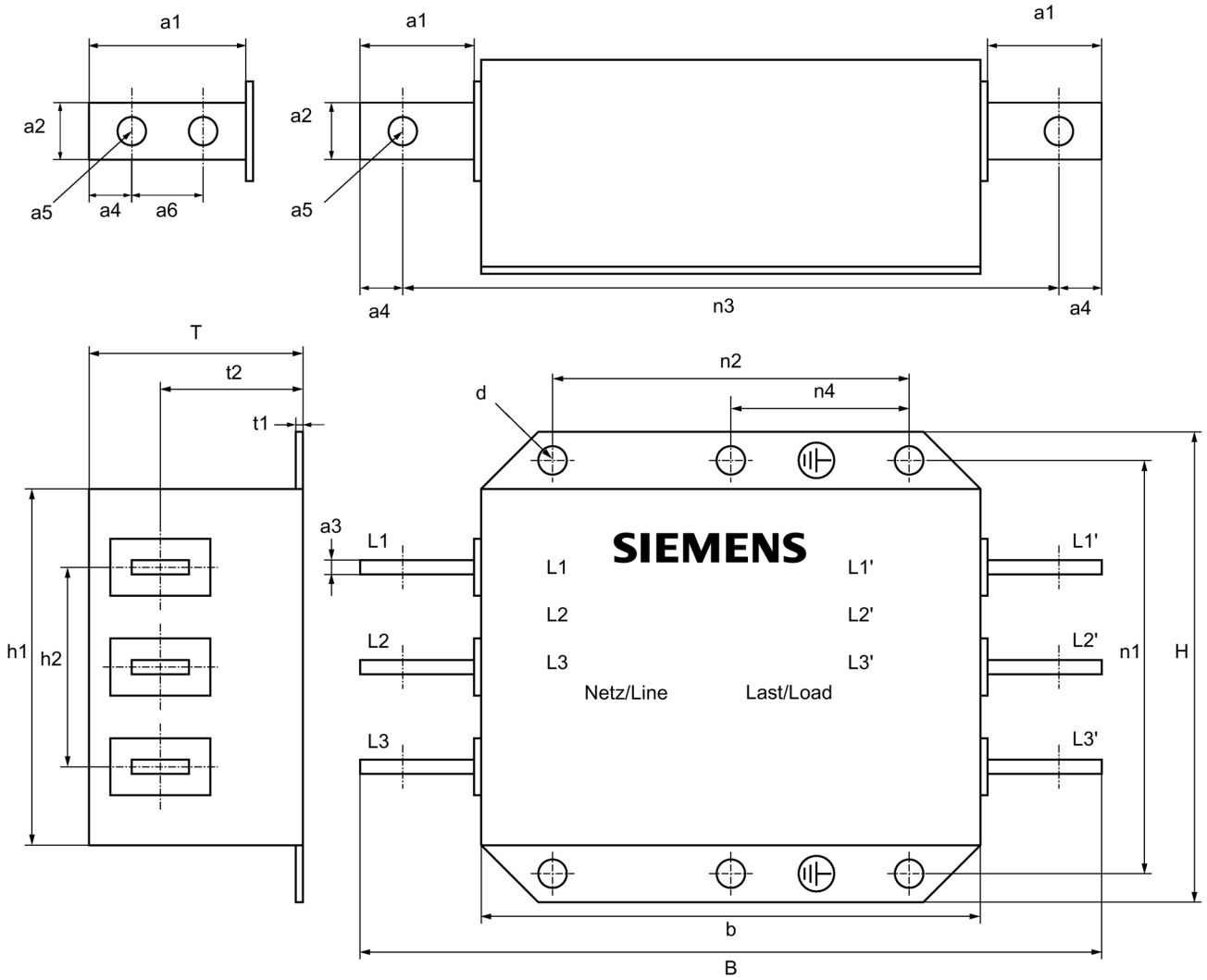

Figure 3-2 Dimension drawing for Line filters for Smart Line Modules and Active Line Modules

3.3 Line filters for Smart Line Modules and Active Line Modules

Table 3- 6 Dimensions of the line filters for Smart Line Modules and Active Line Modules, 380 V ... 480 V 3 AC (all specifications in mm)

	6SL3000- 0BE33-1AA0	6SL3000- 0BE35-0AA0	6SL3760- 0MB00-0AA0	6SL3760- 0MC00-0AA0
W	360	390	425	505
H	240	265	265	265
D	116	140	145	145
a1	40	40	50	90
a2	25	30	50	50
a3	5	8	10	15
a4	15	15	20	20
a5	11	11	14	14
a6	-	-	-	40
b	270	310	315	315
h1	200	215	215	215
h2	100	120	142	142
t1	2	2.5	2.5	2.5
t2	78.2	90	91	91
n1 ¹⁾	220	240	240	240
n2 ¹⁾	210	250	255	255
n3	330	370	385	465
n4	-	-	127.5	127.5
d	9	12	12	12

¹⁾ Lengths n1 and n2 correspond to the distance between holes

3.3 Line filters for Smart Line Modules and Active Line Modules

Table 3- 7 Dimensions of the line filters for Smart Line Modules and Active Line Modules, 500 V ... 690 V 3 AC (all specifications in mm)

	6SL3760-0ME00-0AA0	6SL3760-0MN00-0AA0	6SL3760-0MG00-0AA0	
W	400	425	505	
H	365	365	365	
D	140	145	145	
a1	38	50	90	
a2	30	50	50	
a3	8	15	15	
a4	15	20	20	
a5	11	14	14	
a6	-	-	40	
b	310	315	315	
h1	315	315	315	
h2	120	142	142	
t1	3	2.5	2.5	
t2	90	91	91	
n1 ¹⁾	340	340	310	
n2 ¹⁾	250	255	255	
n3	370	385	465	
n4	125	127.5	127.5	
d	12	12	12	

¹⁾ Lengths n1 and n2 correspond to the distance between holes

3.3.4 Technical data

Table 3- 8 Technical data of the line filters for the Smart Line Modules and Active Line Modules, 3 AC 380 V ... 480 V

Article number		6SL3000- 0BE33-1AA0	6SL3000- 0BE35-0AA0	6SL3760- 0MB00-0AA0	6SL3760- 0MC00-0AA0
Suitable for Smart Line Module	6SL3330-	-	6TE35-5AA3	6TE37-3AA3	6TE41-1AA3 6TE41-3AA3 6TE41-7AA3
Suitable for Active Line Module	6SL3330-	7TE32-1AA3 7TE32-6AA3	7TE33-8AA3 7TE35-0AA3	7TE36-1AA3 7TE37-5AA3	7TE38-4AA3 7TE41-0AA3 7TE41-2AA3 7TE41-4AA3
Rated voltage	V	3 AC 380 -10% (-15% < 1 min) ... 3 AC 480 +10%			
Rated current	A	400	600	840	1405
Power loss	kW	0.042	0.06	0.058	0.111
Line supply/load connection L1, L2, L3/L1', L2', L3'		M10 connecting lugs	M10 connecting lugs	M12 connecting lugs	M12 connecting lugs
PE connection		M8	M10	M10	M10
Degree of protection		IP00	IP00	IP00	IP00
Dimensions					
Width	mm	360	390	425	505
Height	mm	240	265	265	265
Depth	mm	116	140	145	145
Weight	kg	12.7	19.9	25.9	28.9

Table 3- 9 Technical data of the line filters for the Smart Line Modules and Active Line Modules, 3 AC 500 V ... 690 V

Article number		6SL3760- 0ME00-0AA0	6SL3760- 0MN00-0AA0	6SL3760- 0MG00-0AA0	
Suitable for Smart Line Module	6SL3330-	6TG35-5AA3	6TG38-8AA3 6TG41-2AA3	6TG41-7AA3	
Suitable for Active Line Module	6SL3330-	7TG35-8AA3	7TG37-4AA3 7TG41-0AA3	7TG41-3AA3	
Rated voltage	V	3 AC 500 -10% (-15% < 1 min) ... 3 AC 690 +10%			
Rated current	A	600	1025	1270	
Power loss	kW	0.063	0.063	0.097	
Line supply/load connection L1, L2, L3/L1', L2', L3'		M10 connecting lugs	M12 connecting lugs	M12 connecting lugs	
PE connection		M10	M10	M10	
Degree of protection		IP00	IP00	IP00	
Dimensions					
Width	mm	400	425	505	
Height	mm	365	365	365	
Depth	mm	140	145	145	
Weight	kg	27.0	36.7	36.7	



3.4 Line reactors for Basic Line Modules

3.4.1 Description

Line reactors limit low-frequency line harmonics and reduce the load on the semiconductors in the Basic Line Modules. A line reactor must be used in connection with a line filter or if several Basic Line Modules are operated in parallel.

If a Basic Line Module is operated singly and no line filter is used, and with an effective line impedance $u_k > 3\%$, the line reactor is not necessary.

3.4.2 Safety information

 WARNING
Not observing fundamental safety instructions and residual risks Not observing fundamental safety instructions and residual risks listed in Chapter 1 can result in accidents with severe injuries or death. <ul style="list-style-type: none">• Comply with the fundamental safety instructions.• When assessing the risk, take into account remaining risks.
 CAUTION
Burns resulting from high surface temperature The line reactors can become very hot. You can get seriously burnt when touching the surface. <ul style="list-style-type: none">• Mount the line reactors so that contact is not possible. If this is not possible, attach clearly visible and understandable warning notices at hazardous positions.• To prevent adjacent components from suffering damage due to these high temperatures, maintain a clearance of 100 mm on all sides of the line reactors.
NOTICE
Damage to the system caused by the use of inappropriate and not approved line reactors Inappropriate line reactors that have not been approved can damage the Line Modules. Line harmonics that damage/disturb other loads connected to the same line supply can also occur. <ul style="list-style-type: none">• Only use line reactors which are listed in this Manual.

Note

Malfunctions through magnetic fields

Reactors produce magnetic fields that can disturb or damage components and cables.

- Arrange the components and cables at a suitable distance (at least 200 mm) or shield the magnetic fields appropriately.
-

Note

Length of connection cables

The connection cables between line reactor and Line Module, as well as between line reactor and line filter, must be kept as short as possible (max. 5 m).

You must use shielded connection cables, whose cable shields are attached at both ends.

Shielding can only be omitted if the following conditions are met:

- The cables do not exceed 1 m in length.
- The cables are laid flush with the rear metal wall of the control cabinet.
- The cables are laid in a way that keeps them physically separate from signal cables.

Do not route any cables near the line reactor. If this cannot be avoided, observe a minimum distance of 200 mm.

3.4.3 Dimension drawing

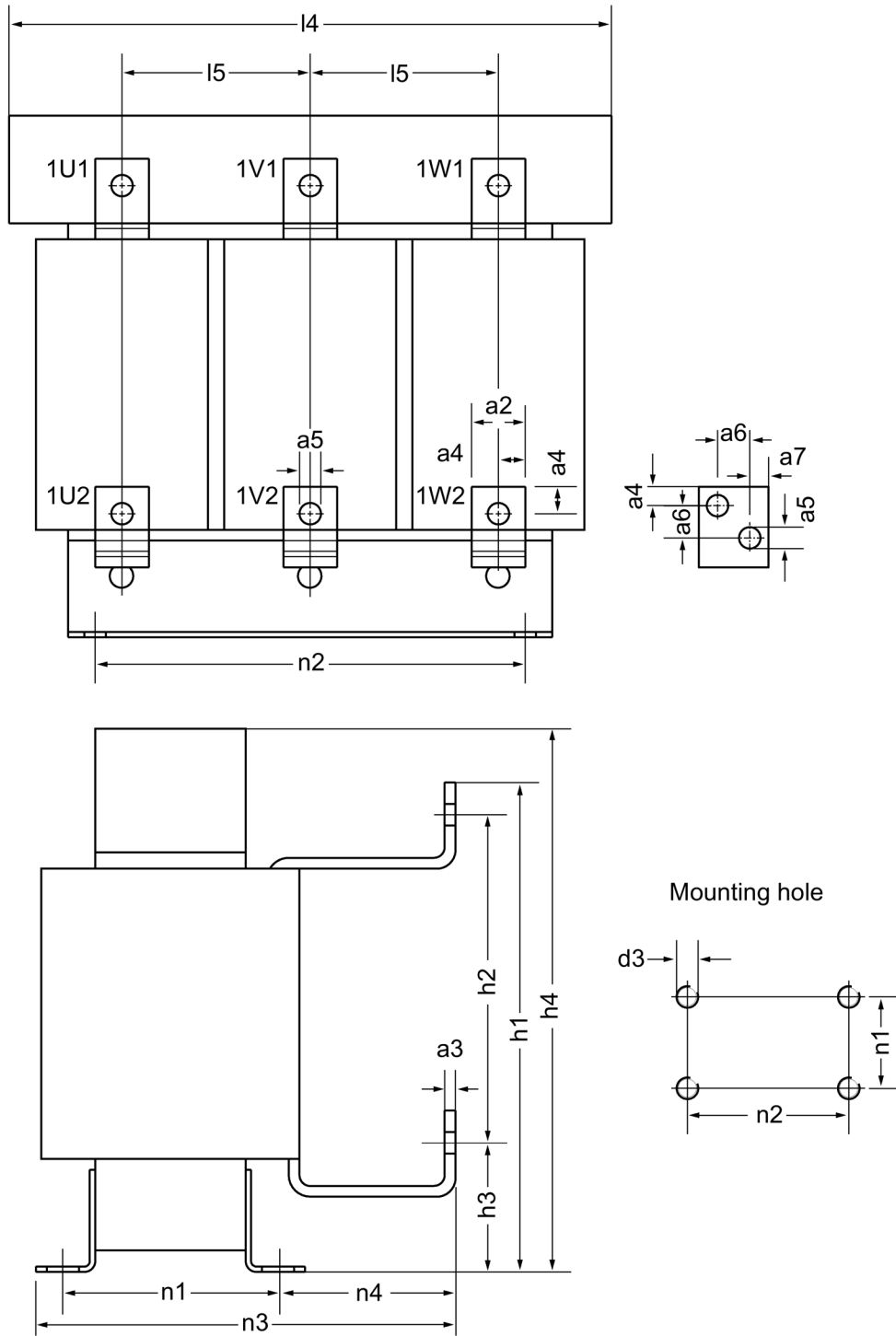

Figure 3-3 Dimension drawing of line reactors for Basic Line Modules

Table 3- 10 Dimensions of line reactors for Basic Line Modules, 3 AC 380 V ... 480 V (all values in mm)

6SL3000-	OCE35-1AA0	OCE37-7AA0	OCE41-0AA0	OCE41-5AA0	OCE41-6AA0
a2	30	30	50	60	60
a3	6	6	8	12	12
a4	15	15	25	25	25
a5	14	14	14	14	14
a6	-	-	-	26	26
a7	-	-	-	17	17
l4	300	300	350	460	410
l5	100	100	120	152.5	152.5
h1	-	-	397	-	-
h2	180	180	252	278	278
h3	60	60	120	120	120
h4	269	269	321	435	419
n1 ¹⁾	118	118	138	155	155
n2 ¹⁾	224	224	264	356	356
n3	212.5	212.5	211.5	235	235
n4	81	81	60	60	60.5
d3	M8	M8	M8	M12	M12

¹⁾ Lengths n1 and n2 correspond to the distance between holes

Table 3- 11 Dimensions of line reactors for Basic Line Modules, 3 AC 500 V ... 690 V (all values in mm)

6SL3000-	OCH32-7AA0	OCH34-8AA0	OCH36-0AA0	OCH41-2AA0	OCH41-6AA0
a2	25	30	30	60	60
a3	5	6	6	12	12
a4	12.5	15	15	25	25
a5	11	14	14	14	14
a6	-	-	-	26	26
a7	-	-	-	17	17
l4	270	350	350	460	410
l5	88	120	120	152.5	152.5
h1	-	-	-	-	-
h2	150	198	198	278	278
h3	60	75	75	120	120
h4	248	321	321	435	422
n1 ¹⁾	101	138	138	155	170
n2 ¹⁾	200	264	264	356	356
n3	200	232.5	232.5	235	247
n4	84.5	81	81	60.5	60.5
d3	M8	M8	M8	M12	M12

¹⁾ Lengths n1 and n2 correspond to the distance between holes

3.4.4 Technical data

Table 3- 12 Technical data of line reactors for Basic Line Modules, 3 AC 380 ... 480 V, Part 1

Article number	6SL3000-	OCE35-1AA0	OCE37-7AA0	OCE41-0AA0	OCE41-5AA0
Suitable for Basic Line Module	6SL3330-	1TE34-2AA3 1TE35-3AA3	1TE38-2AA3	1TE41-2AA3	1TE41-5AA3
Rated power of the Basic Line Module	kW	200 250	400	560	710
Rated voltage	V	3 AC 380 -10% (-15% < 1 min) ... 3 AC 480 +10%			
I _{thmax}	A	508	773	1060	1458
Power loss	kW	0.365	0.351	0.498	0.776
Line/load connection 1U1, 1V1, 1W1, 1U2, 1V2, 1W2		M12 connecting lugs	M12 connecting lugs	M12 connecting lugs	M12 connecting lugs
PE connection		M6 screw	M6 screw	M6 screw	M6 screw
Degree of protection		IP00	IP00	IP00	IP00
Dimensions					
Width	mm	300	300	350	460
Height	mm	269	269	321	435
Depth	mm	212.5	212.5	211.5	235
Weight	kg	38	51.3	69.6	118

Table 3- 13 Technical data of line reactors for Basic Line Modules, 3 AC 380 ... 480 V, Part 2

Article number	6SL3000-	OCE41-6AA0			
Suitable for Basic Line Module	6SL3330-	1TE41-8AA3			
Rated power of the Basic Line Module	kW	900			
Rated voltage	V	3 AC 380 -10% (-15% < 1 min) ... 3 AC 480 +10%			
I _{thmax}	A	1600			
Power loss	kW	0.606			
Line/load connection 1U1, 1V1, 1W1, 1U2, 1V2, 1W2		M12 connecting lugs			
PE connection		M6 screw			
Degree of protection		IP00			
Dimensions					
Width	mm	416			
Height	mm	435			
Depth	mm	235			
Weight	kg	123			

Table 3- 14 Technical data of line reactors for Basic Line Modules, 3 AC 500 ... 690 V, Part 1

Article number	6SL3000-	0CH32-7AA0	0CH34-8AA0	0CH36-0AA0	0CH41-2AA0
Suitable for Basic Line Module	6SL3330-	1TG33-0AA3	1TG34-3AA3	1TG36-8AA3	1TG41-1AA3 1TG41-4AA3
Rated power of the Basic Line Module	kW	250	355	560	900 1100
Rated voltage	V	3 AC 500 -10% (-15% < 1 min) ... 3 AC 690 +10%			
I _{thmax}	A	270	482	597	1167
Power loss	kW	0.277	0.48	0.485	0.783
Line/load connection 1U1, 1V1, 1W1, 1U2, 1V2, 1W2		M10 connecting lugs	M12 connecting lugs	M12 connecting lugs	M12 connecting lugs
PE connection		M6 screw	M6 screw	M6 screw	M6 screw
Degree of protection		IP00	IP00	IP00	IP00
Dimensions					
Width	mm	270	350	350	460
Height	mm	248	321	321	435
Depth	mm	200	232.5	232.5	235
Weight	kg	27.9	55.6	63.8	147

Table 3- 15 Technical data of line reactors for Basic Line Modules, 3 AC 500 ... 690 V, Part 2

Article number	6SL3000-	0CH41-6AA0			
Suitable for Basic Line Module	6SL3330-	1TG41-8AA3			
Rated power of the Basic Line Module	kW	1500			
Rated voltage	V	3 AC 500 -10% (-15% < 1 min) ... 3 AC 690 +10%			
I _{thmax}	A	1600			
Power loss	kW	0.977			
Line/load connection 1U1, 1V1, 1W1, 1U2, 1V2, 1W2		M12 connecting lugs			
PE connection		M6 screw			
Degree of protection		IP00			
Dimensions					
Width	mm	416			
Height	mm	435			
Depth	mm	250			
Weight	kg	134			

3.5 Line reactors for Smart Line Modules

3.5.1 Description

Line reactors limit low-frequency line harmonics and reduce the load on the semiconductors in the Smart Line Modules. For this reason, line reactors must always be provided when Smart Line Modules are used.

3.5.2 Safety information

 WARNING
Not observing fundamental safety instructions and residual risks
Not observing fundamental safety instructions and residual risks listed in Chapter 1 can result in accidents with severe injuries or death.
<ul style="list-style-type: none">• Comply with the fundamental safety instructions.• When assessing the risk, take into account remaining risks.

 CAUTION
Burns resulting from high surface temperature
The line reactors can become very hot. You can get seriously burnt when touching the surface.
<ul style="list-style-type: none">• Mount the line reactors so that contact is not possible. If this is not possible, attach clearly visible and understandable warning notices at hazardous positions.• To prevent adjacent components from suffering damage due to these high temperatures, maintain a clearance of 100 mm on all sides of the line reactors.

NOTICE
Damage to the system caused by the use of inappropriate and not approved line reactors
Inappropriate line reactors that have not been approved can damage the Line Modules.
Line harmonics that damage/disturb other loads connected to the same line supply can also occur.
<ul style="list-style-type: none">• Only use line reactors which are listed in this Manual.

Note

Malfunctions through magnetic fields

Reactors produce magnetic fields that can disturb or damage components and cables.

- Arrange the components and cables at a suitable distance (at least 200 mm) or shield the magnetic fields appropriately.
-

Note

Length of connection cables

The connection cables between line reactor and Line Module, as well as between line reactor and line filter, must be kept as short as possible (max. 5 m).

You must use shielded connection cables, whose cable shields are attached at both ends.

Shielding can only be omitted if the following conditions are met:

- The cables do not exceed 1 m in length.
- The cables are laid flush with the rear metal wall of the control cabinet.
- The cables are laid in a way that keeps them physically separate from signal cables.

Do not route any cables near the line reactor. If this cannot be avoided, observe a minimum distance of 200 mm.

3.5.3 Dimension drawing

Line reactor 6SL3000-0EE36-2AA0

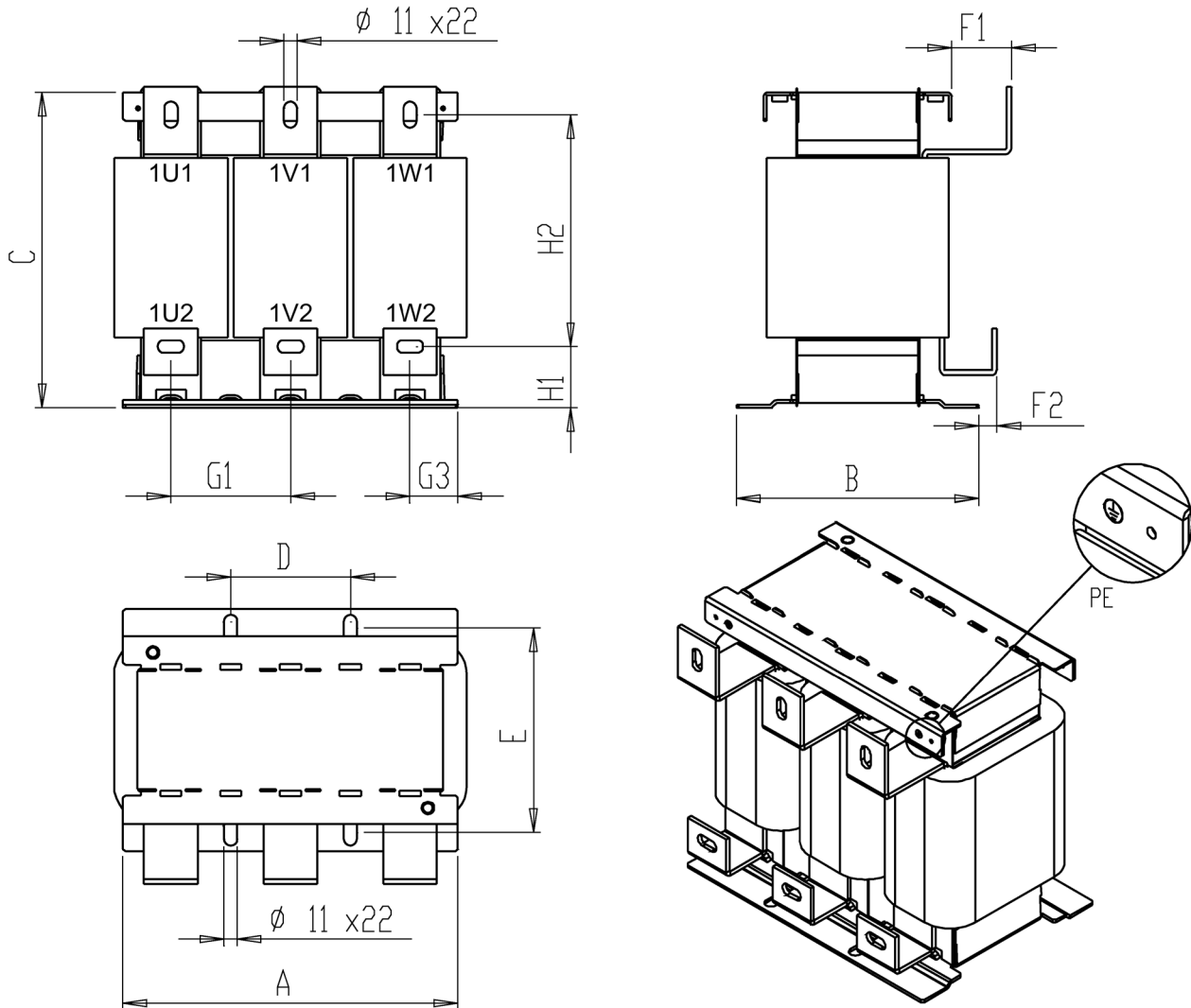

Figure 3-4 Dimension drawing of line reactor 6SL3000-0EE36-2AA0

Table 3- 16 Dimensions (all dimensions in mm)

A	B	C	D ¹	E ¹	F1	F2	G1
280	203	264	100	171	50	15	100
G2	G3	H1	H2	H3			
-	40	51	194	-			

1) Lengths D and E correspond to the distance between holes

Line reactor 6SL3000-0EE38-8AA0

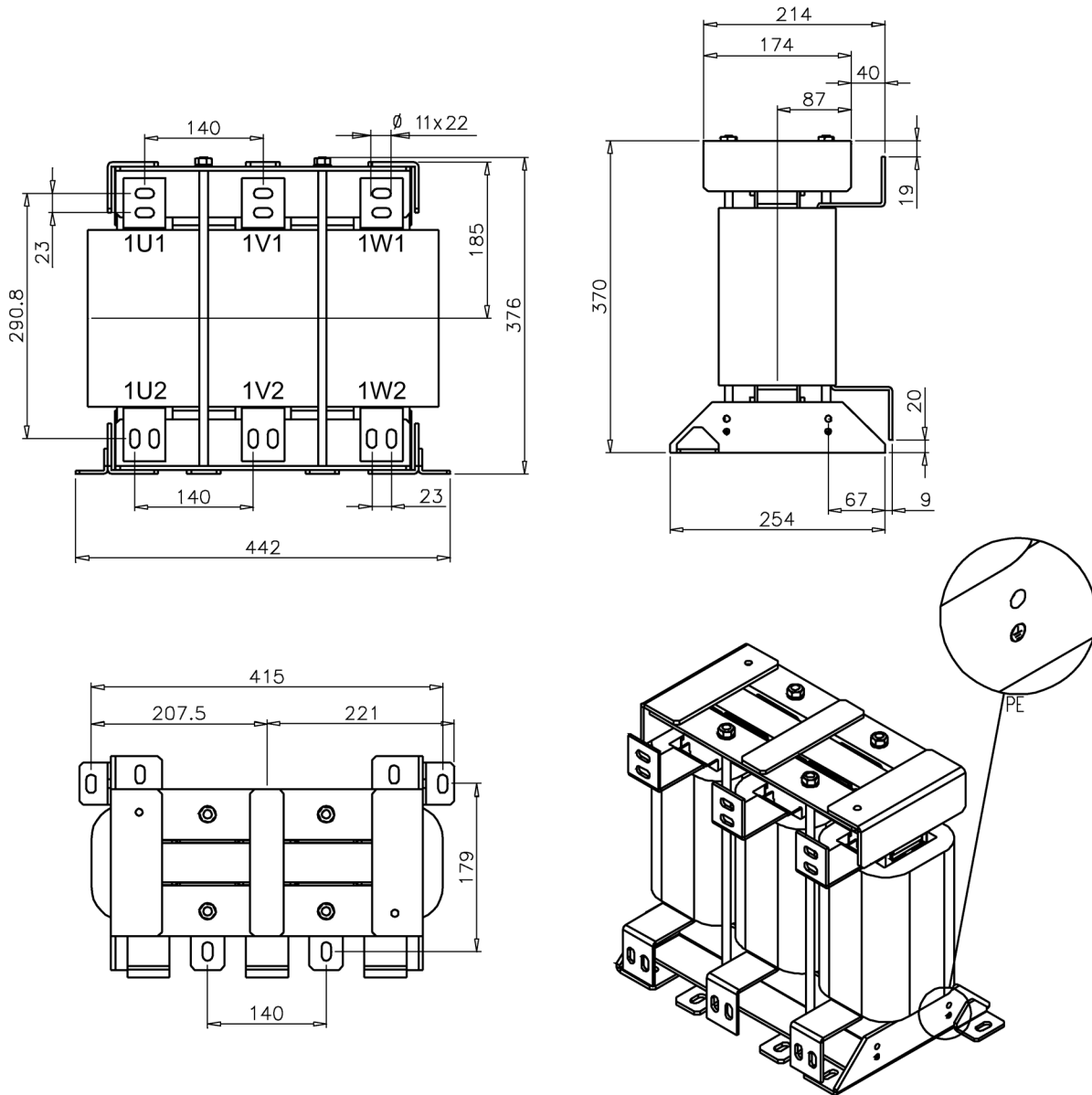

Figure 3-5 Dimension drawing of line reactor 6SL3000-0EE38-8AA0, all dimensions in mm

Line reactor 6SL3000-0EE41-4AA0

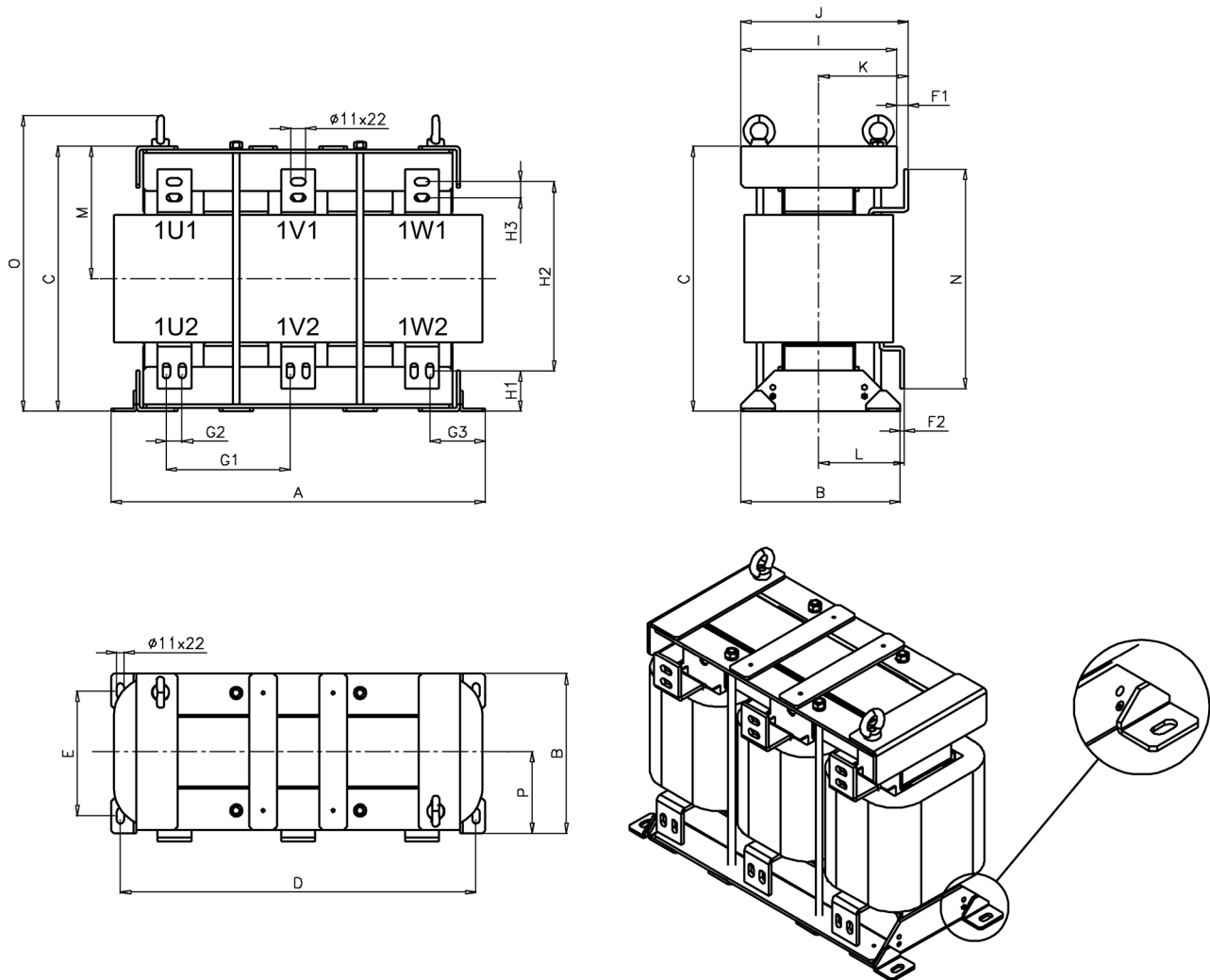

Figure 3-6 Dimension drawing of line reactor 6SL3000-0EE41-4AA0

Table 3- 17 Dimensions (all dimensions in mm)

A	B	C	D ¹	E ¹	F1	F2	G1
544	232	386	517	182	17	6	180
G2	G3	H1	H2	H3	I	J	K
23	80.5	59	276	23	227	244	130.5
L	M	N	O	P			
122	193	320	431	116			

1) Lengths D and E correspond to the distance between holes

Note

Remove the crane lifting eyes

The crane lifting eyes can be removed after installation.

Line reactor 6SL3000-0EH34-7AA0

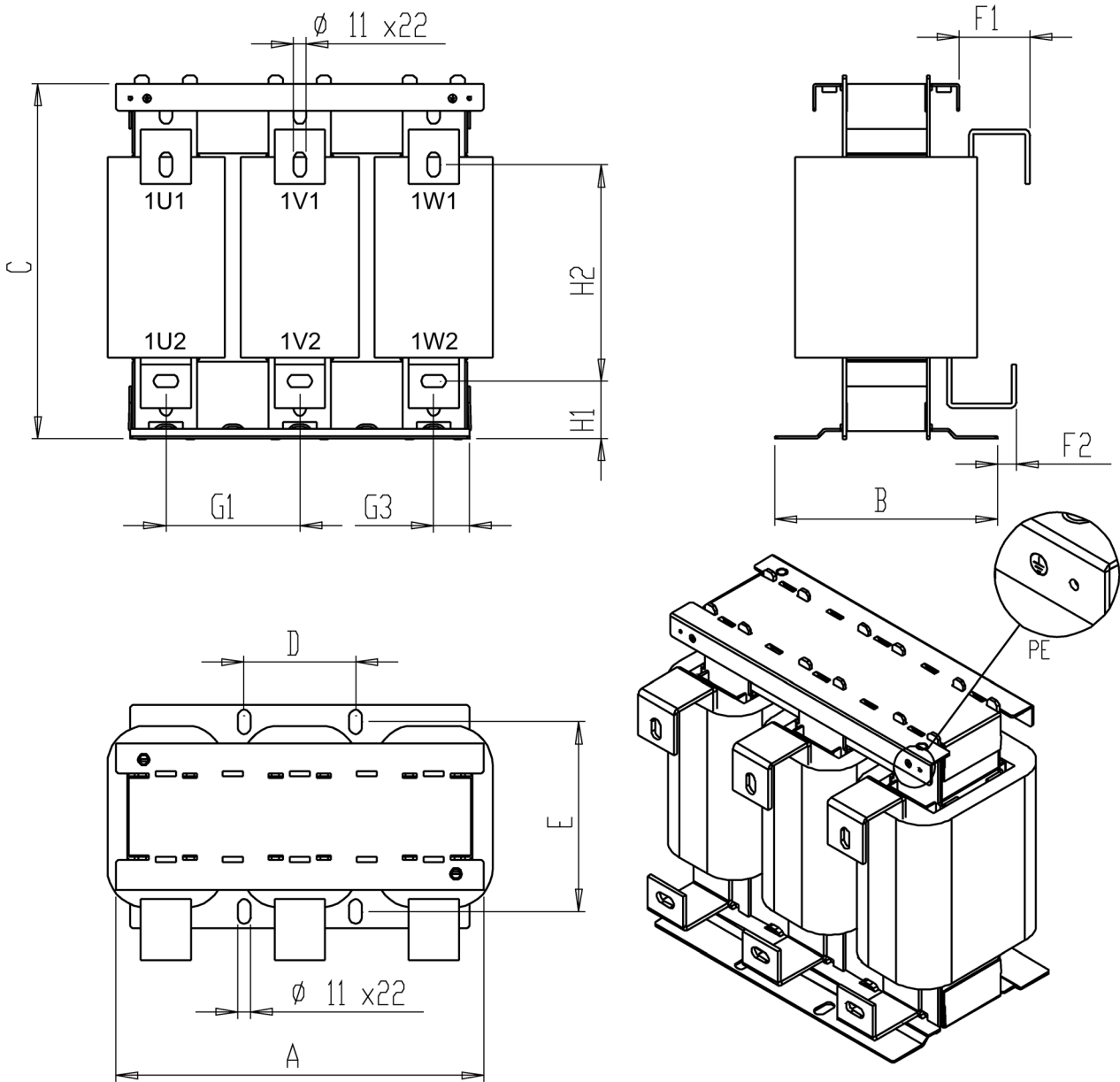

Figure 3-7 Dimension drawing of line reactor 6SL3000-0EH34-7AA0

Table 3- 18 Dimensions (all dimensions in mm)

A	B	C	D ¹⁾	E ¹⁾	F1	F2	G1
330	200	318	100	170	63	16.5	120
G2	G3	H1	H2	H3			
-	32	51	194	-			

1) Lengths D and E correspond to the distance between holes

Line reactor 6SL3000-0EH37-6AA0

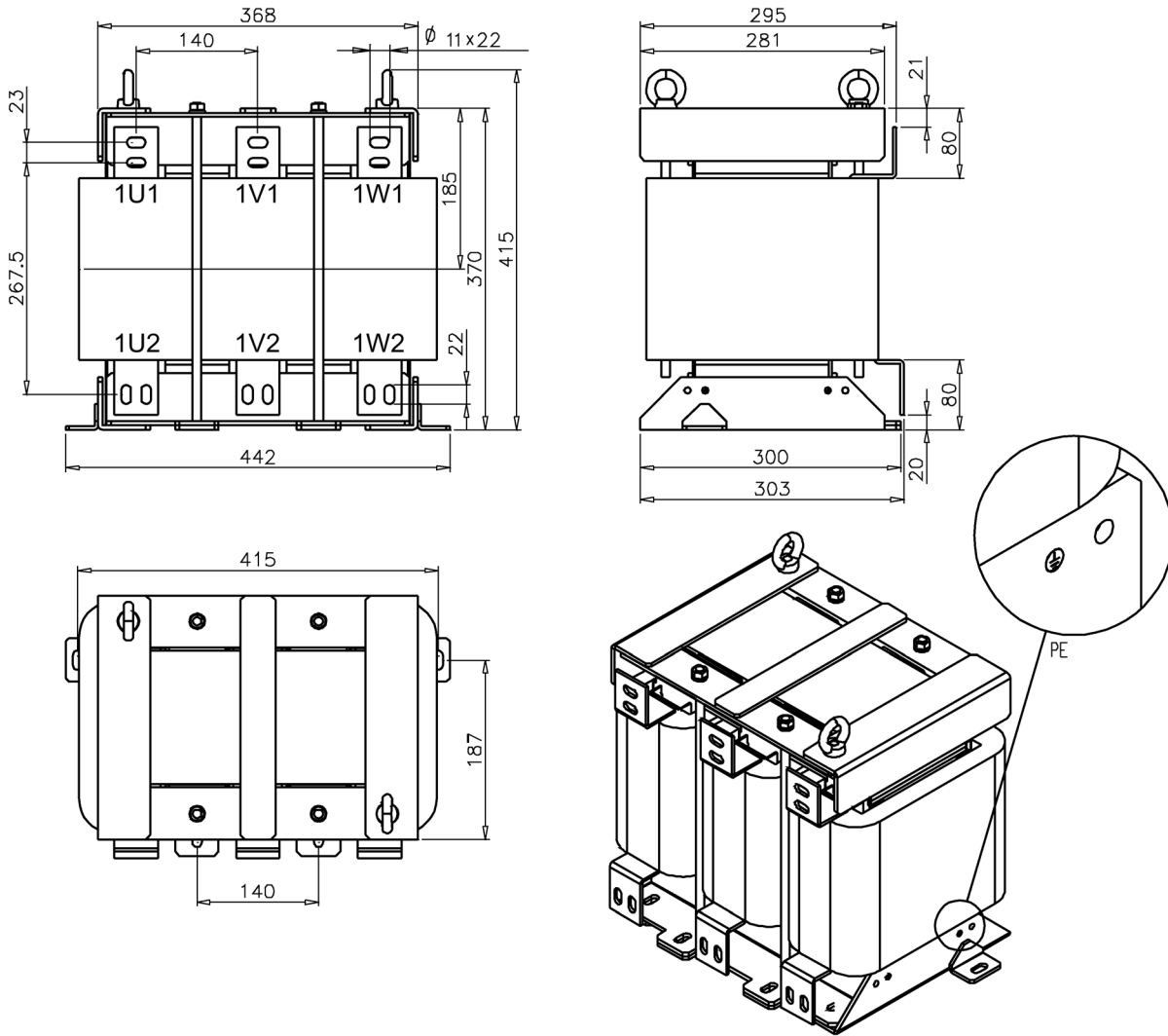

Figure 3-8 Dimension drawing of line reactor 6SL3000-0EE37-6AA0, all dimensions in mm

Note

Remove the crane lifting eyes

The crane lifting eyes can be removed after installation.

Line reactor 6SL3000-0EE41-4AA0

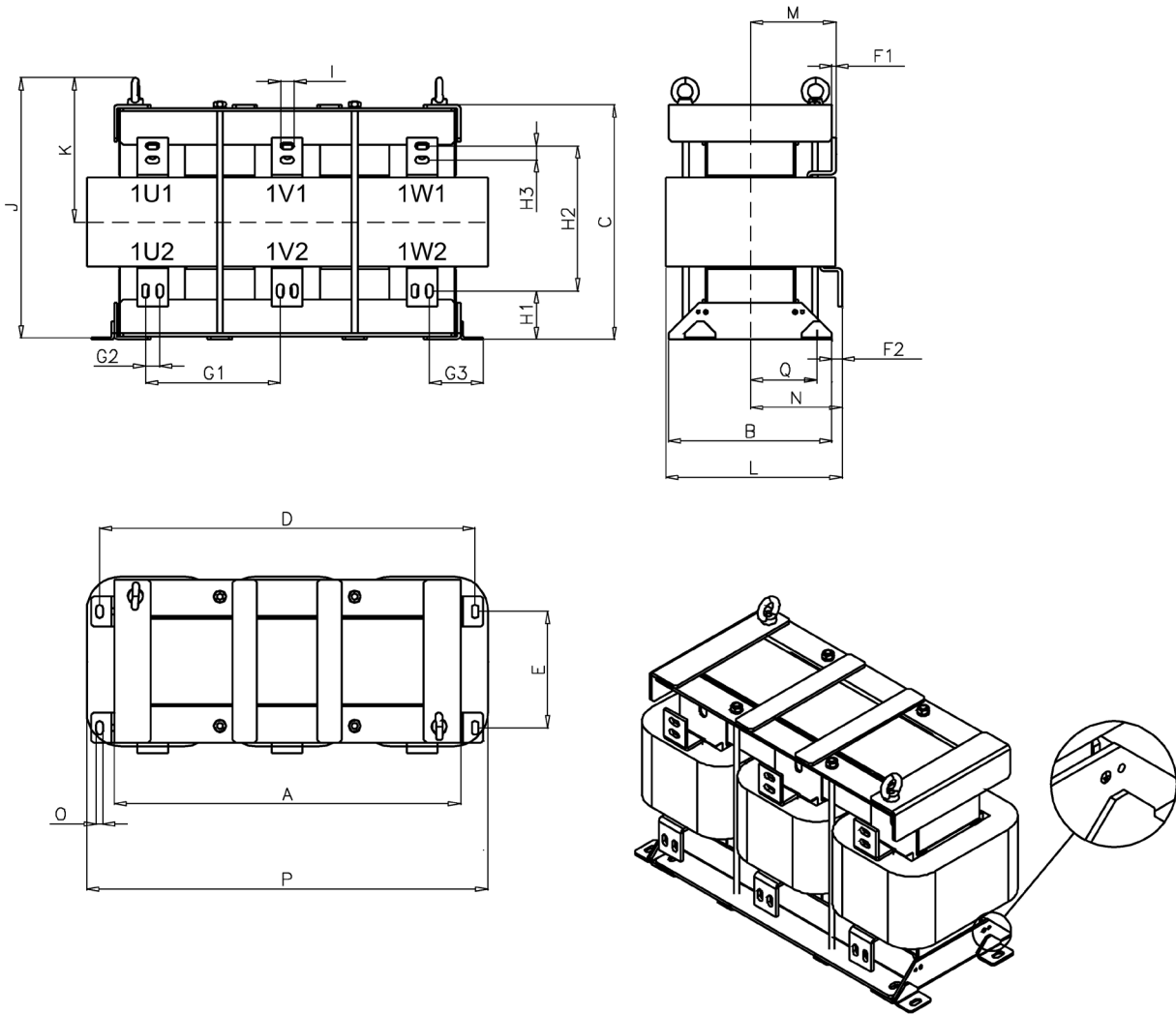

Figure 3-9 Dimension drawing of line reactor 6SL3000-0EH41-4AA0

Table 3- 19 Dimensions (all dimensions in mm)

A	B	C	D ¹⁾	E ¹⁾	F1	F2	G1
566	267	383	613	190	6	16	220
G2	G3	H1	H2	H3	I	J	K
23	88.5	79.5	236.5	23	22	426	213
L	M	N	O	P	Q		
288	139.5	149.5	11	655	108.5		

1) Lengths D and E correspond to the distance between holes

Note

Remove the crane lifting eyes

The crane lifting eyes can be removed after installation.

3.5.4 Technical data

Table 3- 20 Technical data, line reactors for Smart Line Modules, 3 AC 380 ... 480 V

Article number	6SL3000-	0EE36-2AA0	0EE38-8AA0	0EE41-4AA0	
Suitable for Smart Line Module	6SL3330-	6TE35-5AA3 6TE37-3AA3	6TE41-1AA3	6TE41-3AA3 6TE41-7AA3	
Rated power of the Smart Line Module	kW	250 355	500	630 800	
Rated voltage	V	3 AC 380 -10% (-15% < 1 min) ... 3 AC 480 +10%			
I _{thmax}	A	615	885	1430	
Power loss 50/60 Hz	kW	0.500/0.560	0.725/0.810	0.925/1.080	
Line/load connection 1U1, 1V1, 1W1, 1U2, 1V2, 1W2		M10 connecting lugs	M10 connecting lugs	M10 connecting lugs	
PE connection		M6, 4x	M6, 4x	M6, 4x	
Degree of protection		IP00	IP00	IP00	
Dimensions					
Width	mm	300	442	544	
Height	mm	264	376	386	
Depth	mm	203	263	232	
Weight	kg	57	85.5	220	

Table 3- 21 Technical data, line reactors for Smart Line Modules, 3 AC 500 ... 690 V

Article number	6SL3000-	0EH34-7AA0	0EH37-6AA0	0EH41-4AA0	
Suitable for Smart Line Module	6SL3330-	6TG35-5AA3	6TG38-8AA3	6TG41-7AA3 6TG41-2AA3	
Rated power of the Smart Line Module	kW	450	710	1000 1400	
Rated voltage	V	3 AC 500 -10% (-15% < 1 min) ... 3 AC 690 +10%			
I _{thmax}	A	465	760	1430	
Power loss 50/60 Hz	kW	0.720/0.820	0.840/0.950	1.680/1.850	
Line/load connection 1U1, 1V1, 1W1, 1U2, 1V2, 1W2		M10 connecting lugs	M10 connecting lugs	M10 connecting lugs	
PE connection		M6, 4x	M6, 4x	M6, 4x	
Degree of protection		IP00	IP00	IP00	
Dimensions					
Width	mm	360	442	655	
Height	mm	325	370	383	
Depth	mm	229	303	288	
Weight	kg	58	145	239	

3.6 Active Interface Modules

3.6.1 Description

Active Interface Modules are used in conjunction with the Active Line Modules in chassis format. The Active Interface Modules contain a Clean Power Filter with basic RI suppression, the precharging circuit for the Active Line Module, the line voltage sensing circuit and monitoring sensors.

The bypass contactor is an integral component in frame sizes FI and GI, which ensures a highly compact design. The bypass contactor must be provided separately for frame sizes HI and JI.

The vast majority of line harmonics are suppressed by the Clean Power Filter.

The Active Interface Module contains:

- Clean Power Filter
- Line reactor
- Precharging circuit
- Bypass contactor (frame sizes FI/GI)
- Voltage Sensing Module VSM10
- Fan

Table 3- 22 Active Interface Module

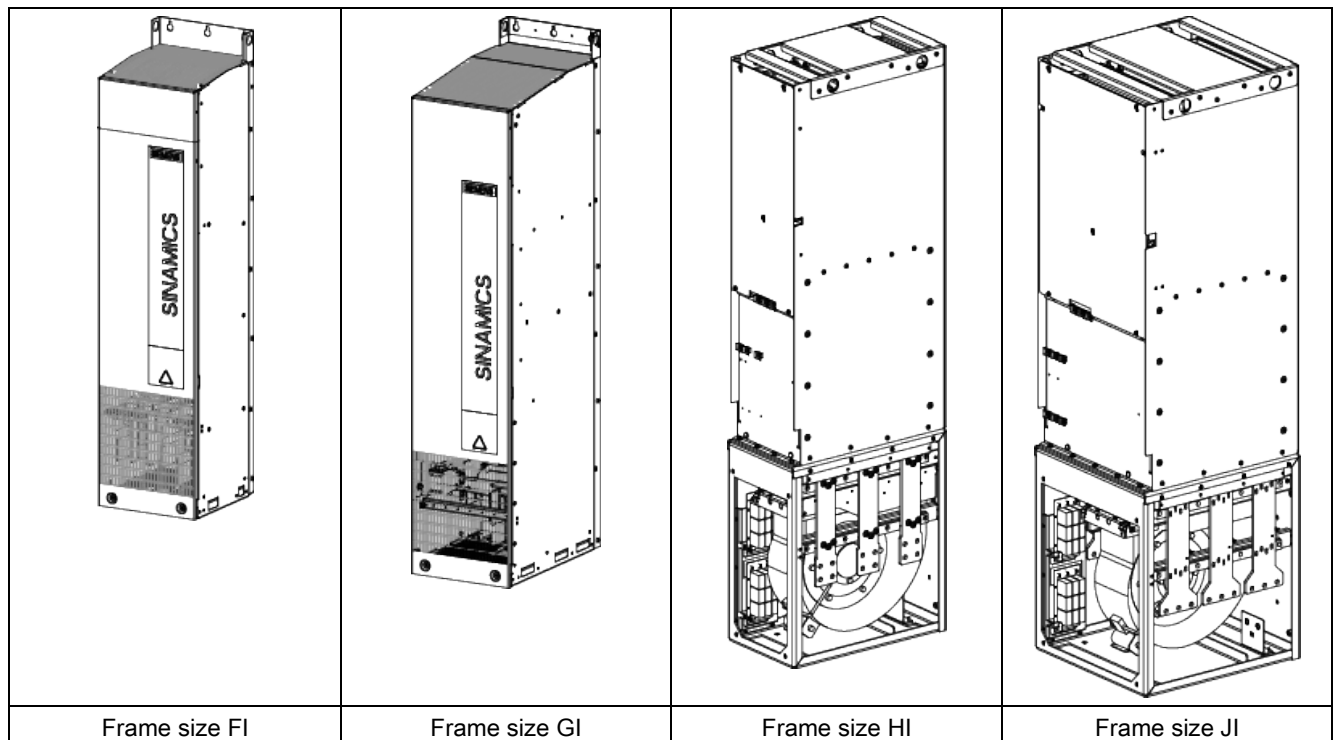

3.6.2 Safety information

 WARNING
Not observing fundamental safety instructions and residual risks
Not observing fundamental safety instructions and residual risks listed in Chapter 1 can result in accidents with severe injuries or death.
<ul style="list-style-type: none">• Comply with the fundamental safety instructions.• When assessing the risk, take into account remaining risks.



 WARNING
Electric shock due to unconnected cable shields
Hazardous touch voltages can occur through capacitive cross-coupling due to unconnected cable shields.
<ul style="list-style-type: none">• Connect cable shields to a grounded housing potential on both sides.



 WARNING
High leakage currents when the protective conductor in the line feeder cable is interrupted
The drive components conduct a high leakage current via the protective conductor. Touching conductive parts when the protective conductor is interrupted can result in death or serious injury.
<ul style="list-style-type: none">• Ensure that the external protective conductor satisfies at least one of the following conditions:<ul style="list-style-type: none">– It has been installed so that it is protected against mechanical damage. ¹⁾– For an individual core, it has a cross-section of at least 10 mm² Cu.– If it is a conductor of a multi-conductor cable, it has a cross-section of at least 2.5 mm² Cu.– It has a second protective conductor in parallel with the same cross-section.– It complies with the local regulations for equipment with increased leakage current.
¹⁾ Cables laid within control cabinets or closed machine housings are considered to be adequately protected against mechanical damage.

 WARNING
Fire due to inadequate ventilation clearances
Inadequate ventilation clearances can cause overheating of components with subsequent fire and smoke. This can cause serious injury or even death. This can also result in increased failures and shorter service lives for devices/systems.
<ul style="list-style-type: none">• Observe the ventilation clearances above, below, and in front of the component, which are specified in the dimension drawings.

3.6.3 Interface description

3.6.3.1 Overview

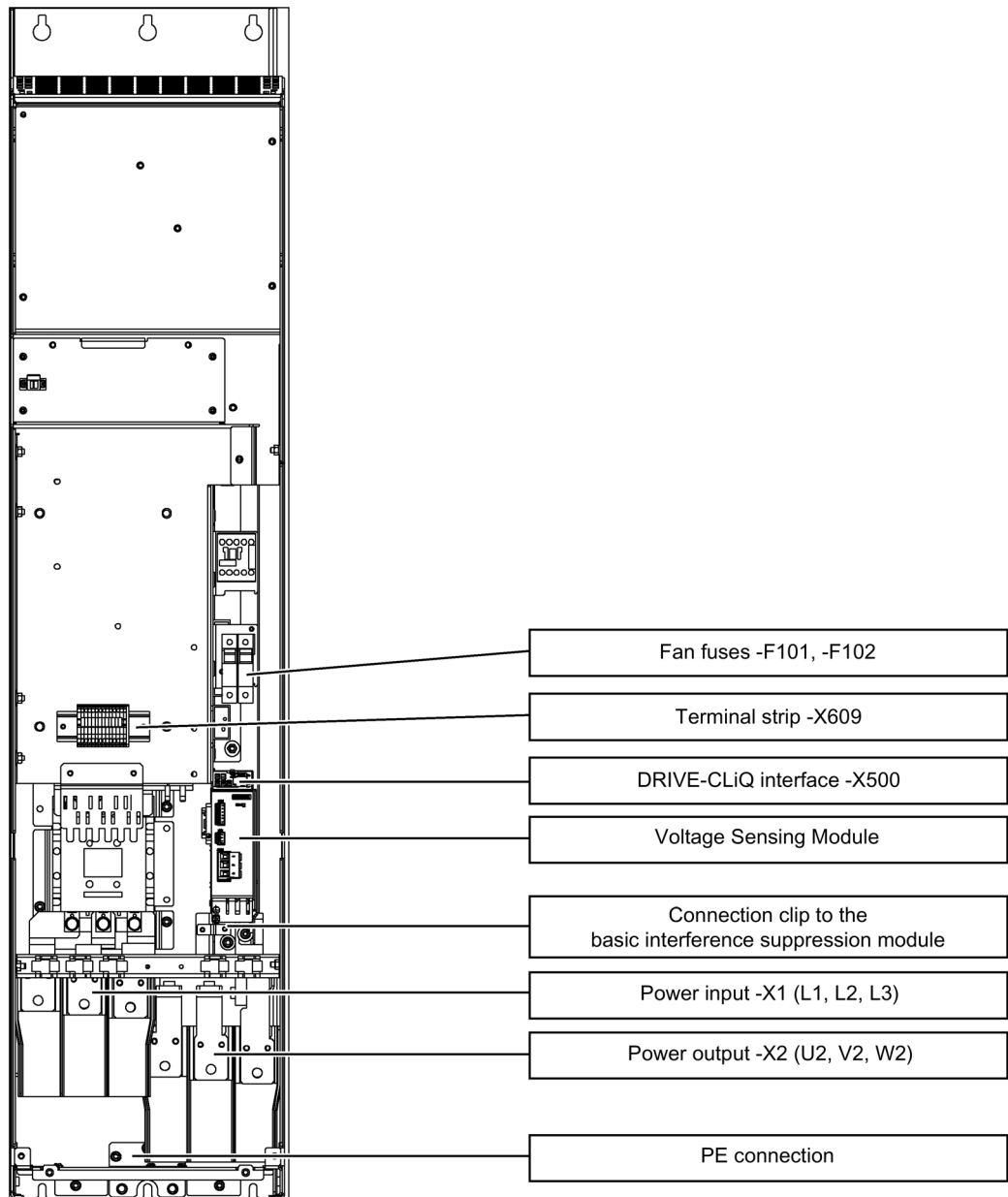

Figure 3-10 Interface overview in the Active Interface Module, frame size FI

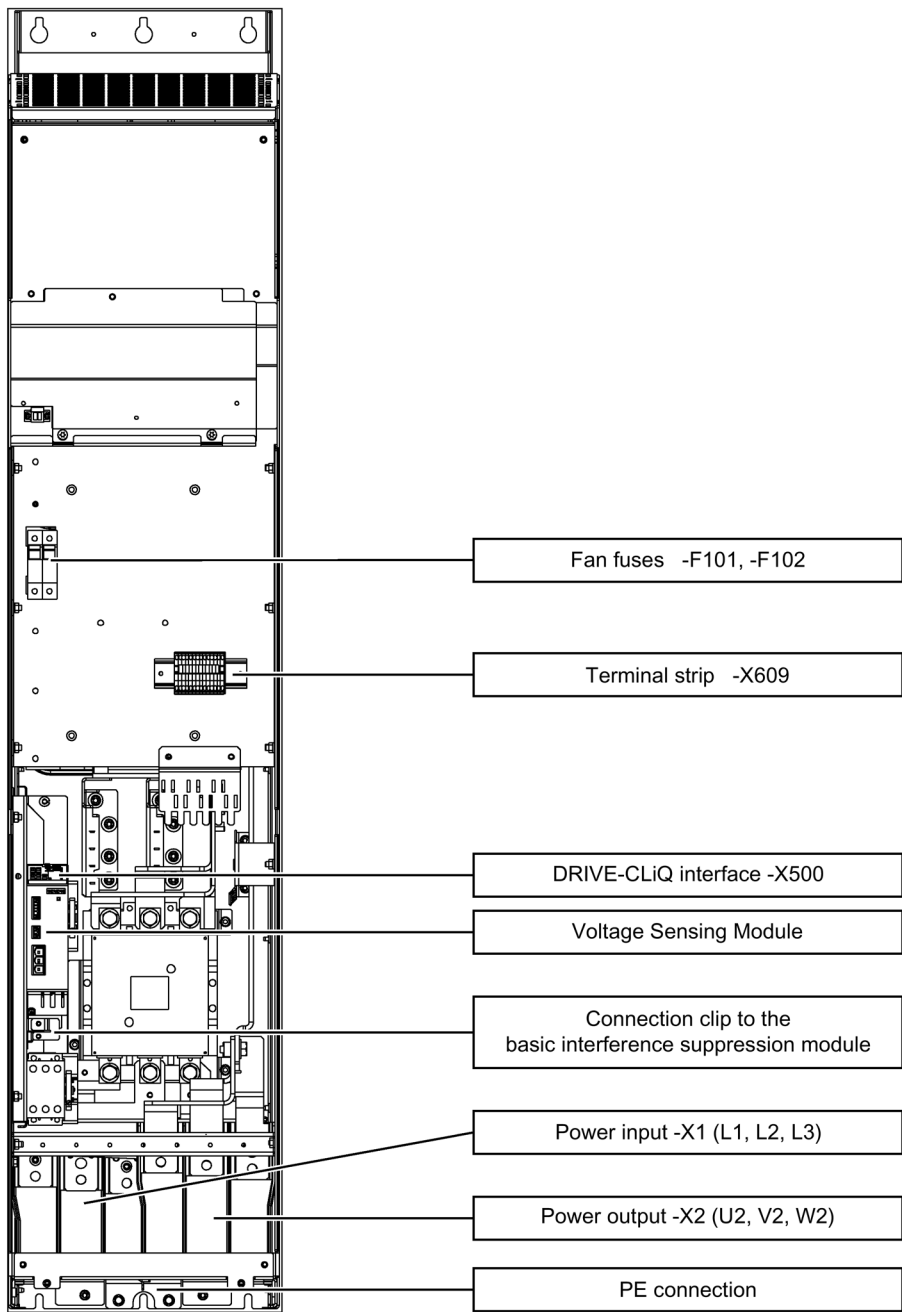

Figure 3-11 Interface overview in the Active Interface Module, frame size GI

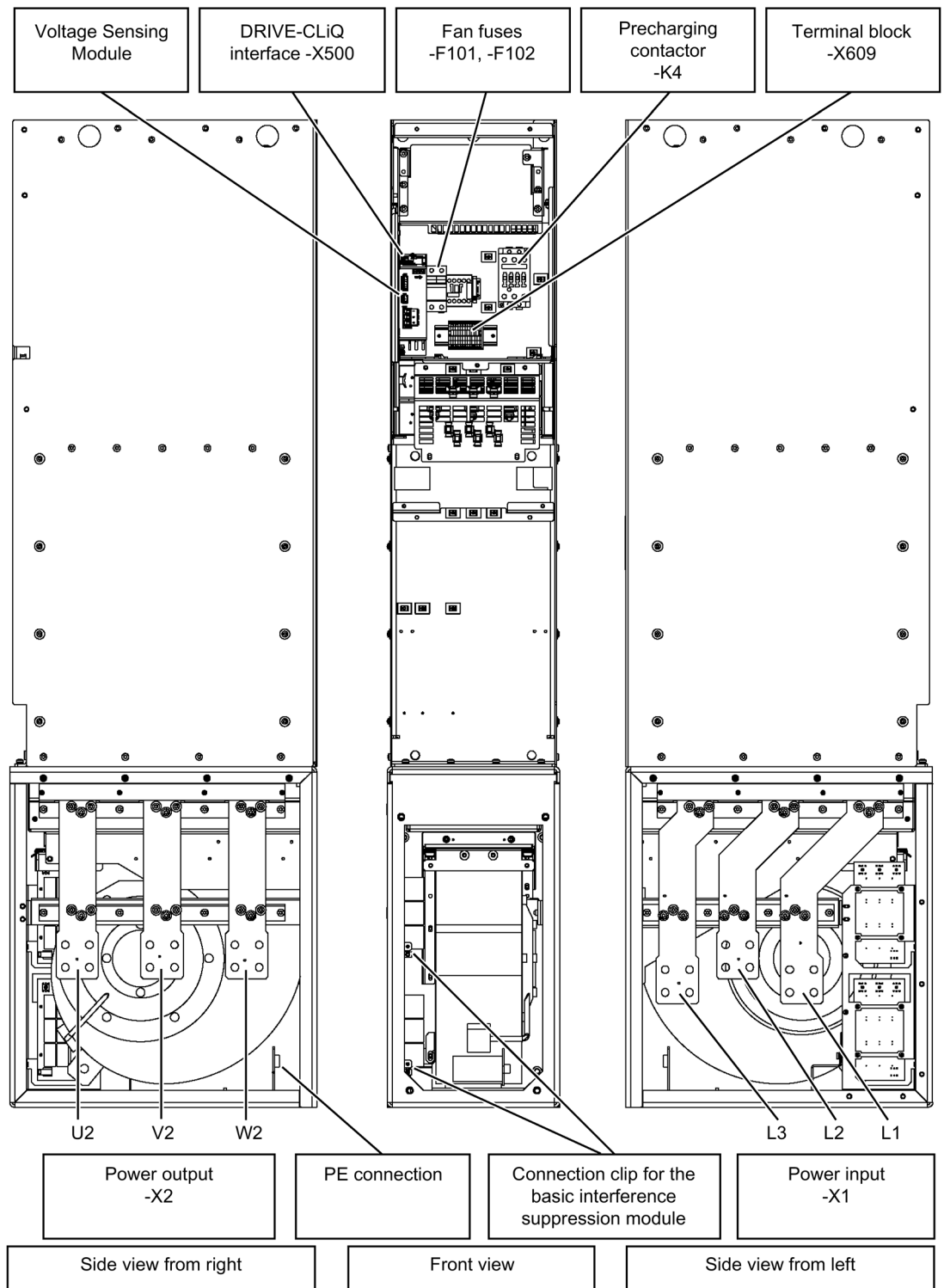

Figure 3-12 Interface overview in the Active Interface Module, frame size HI

3.6 Active Interface Modules

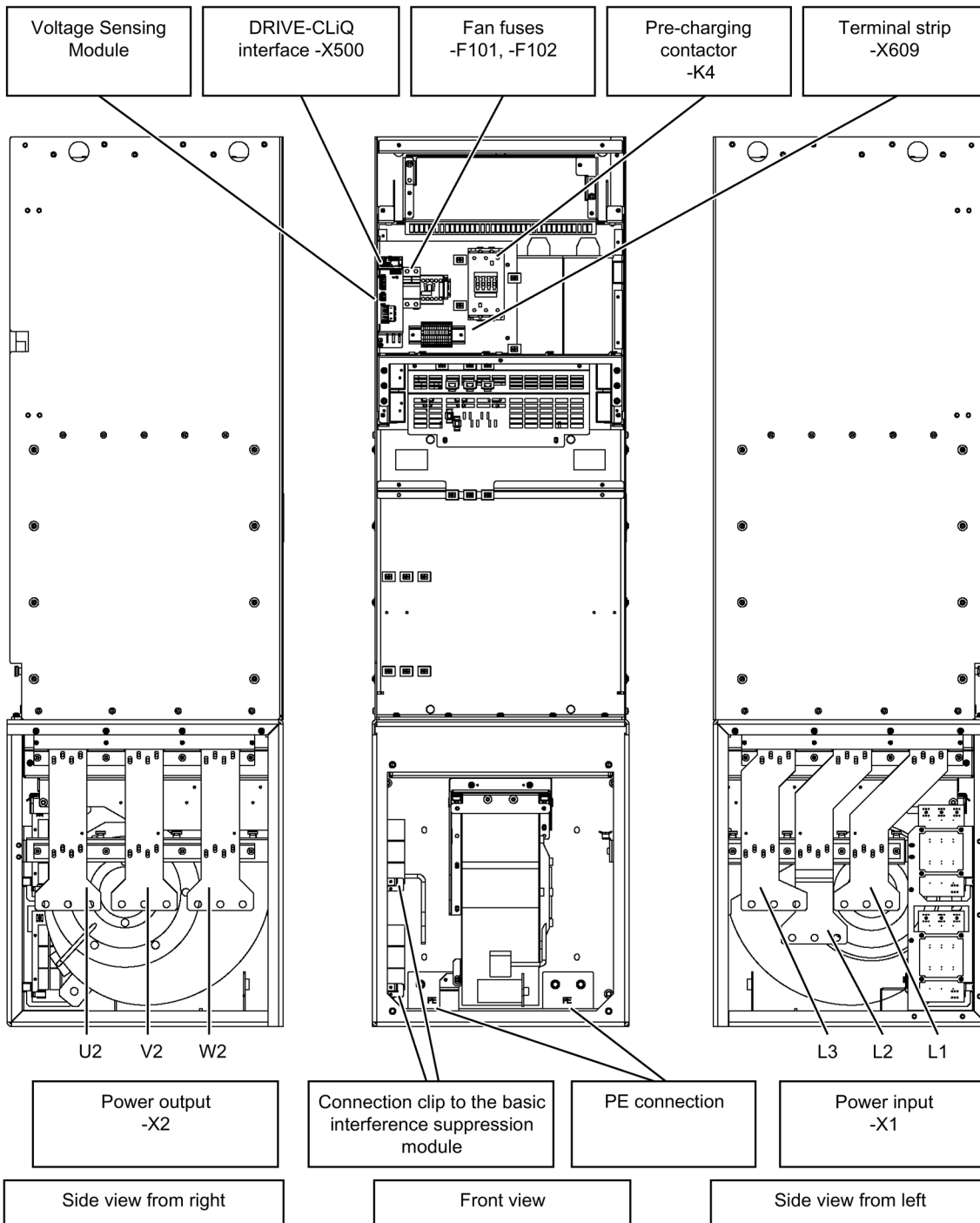

Figure 3-13 Interface overview in the Active Interface Module, frame size JI

3.6.3.2 Connection example

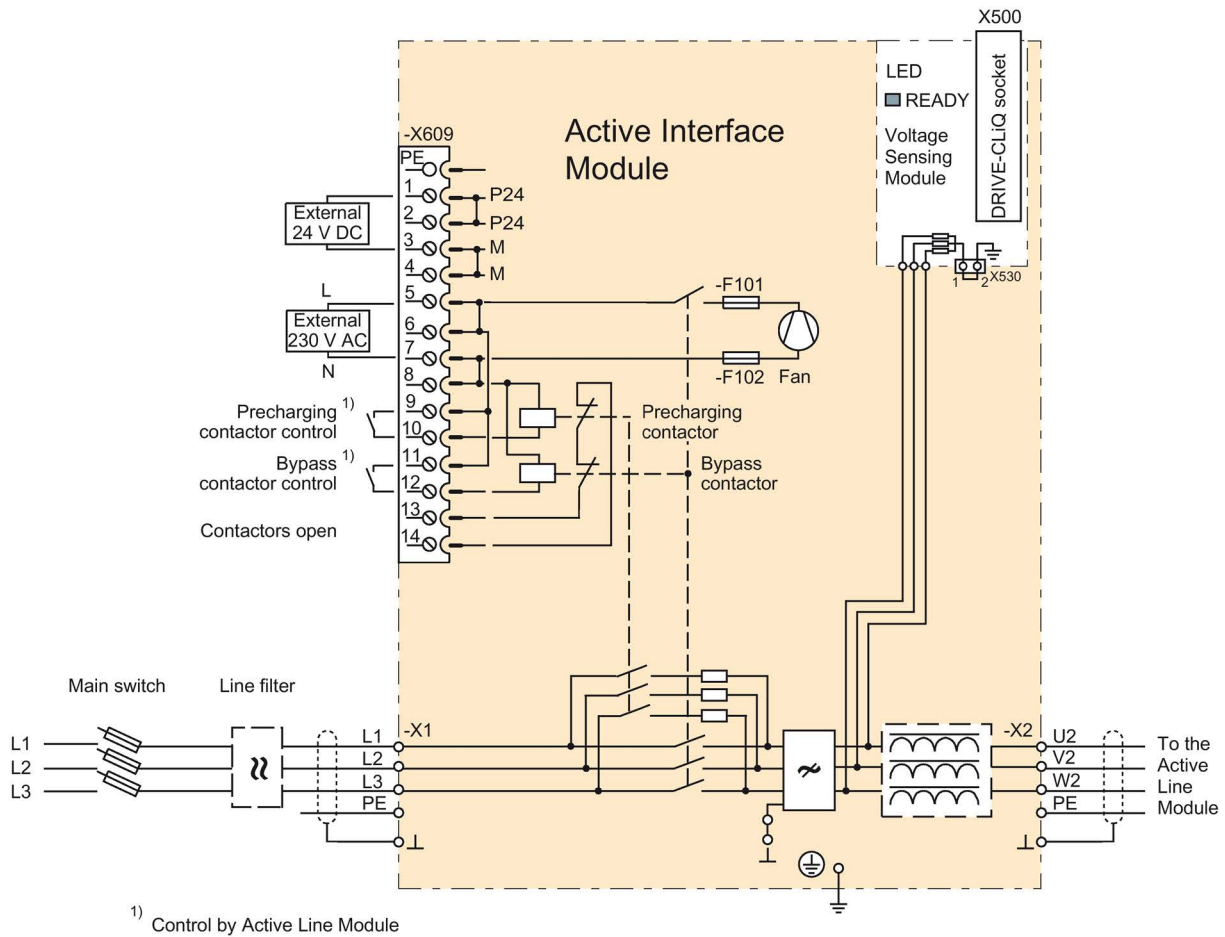

Figure 3-14 Connection example Active Interface Module, frame sizes FI / GI

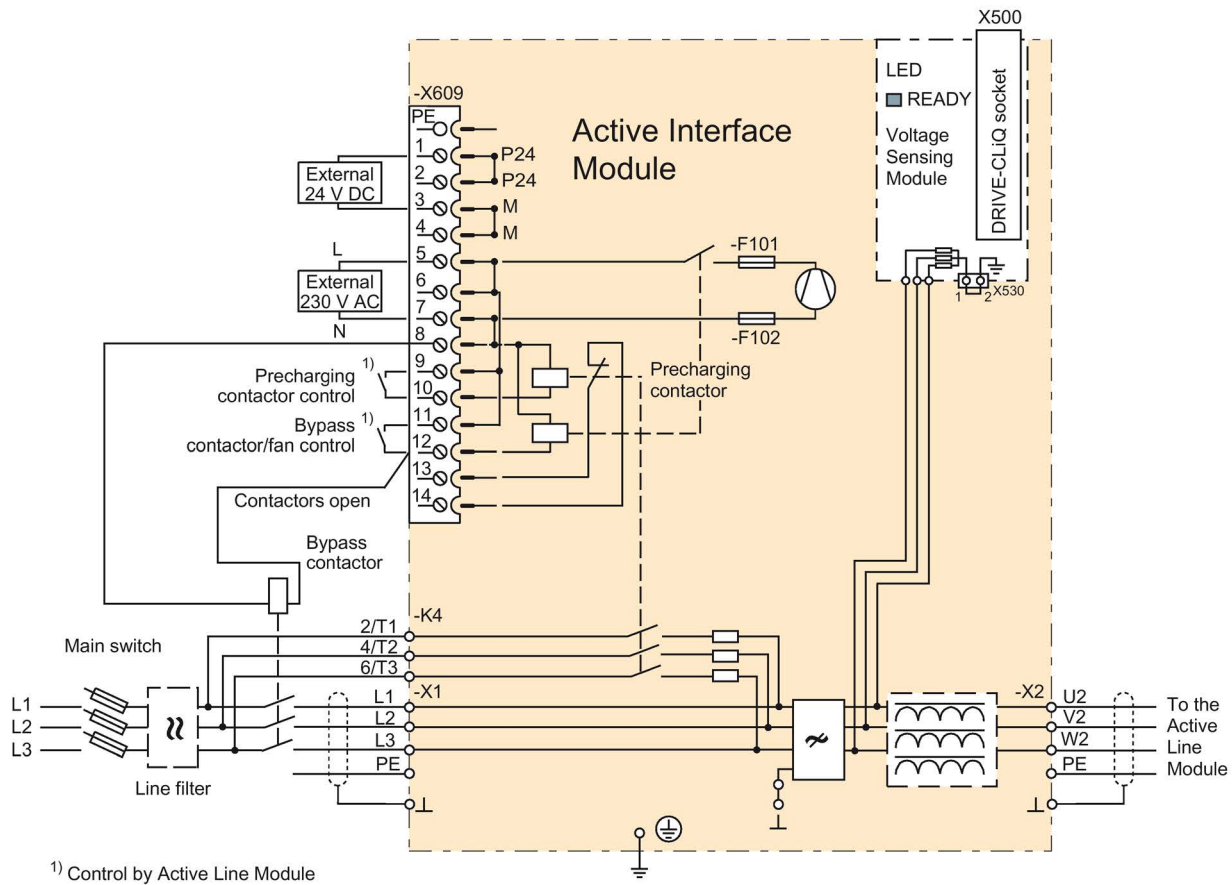

Figure 3-15 Connection example Active Interface Module, frame sizes HI / JI

NOTICE
<p>Damage to the devices as a result of excessively long switching times of the bypass contactor</p> <p>When using a bypass contactor with excessively long switching times (maximum 500 ms), the required overlap phase is not guaranteed, where both contactors are simultaneously pulled-in. As a consequence, the Active Interface Module can be overloaded and destroyed.</p> <ul style="list-style-type: none"> • Only use Siemens bypass contactors; the associated data are provided in the technical data.
NOTICE
<p>Damage to the device due to different phase sequence in the precharging and main circuits</p> <p>During the brief overlap period where both contactors are simultaneously closed, the precharging resistors of the Active Interface Module could be overloaded and destroyed due to different phase sequences in the precharging and main circuits.</p> <ul style="list-style-type: none"> • Connect the power cables to the precharging and main circuits with the same phase sequence.

3.6.3.3 Line/load connection

Table 3- 23 Connections for the Active Interface Module

Terminals	Designations
X1: L1, L2, L3 X2: U2, V2, W2	Voltage: <ul style="list-style-type: none"> 3 AC 380 V -10% (-15% < 1 min) ... 3 AC 480 V +10% 3 AC 500 V -10% (-15% < 1 min) ... 3 AC 690 V +10% Frequency: 47 ... 63 Hz Connecting thread: <ul style="list-style-type: none"> Frame sizes FI / GI: M10 / 25 Nm for cable lugs in accordance with DIN 46234 / DIN 46235 ¹⁾ Frame sizes HI / JI: M12 / 50 Nm for cable lugs in accordance with DIN 46234 / DIN 46235 ¹⁾
K4: 2/T1, 4/T2, 6/T3 (for frame sizes HI / JI only)	Connection for pre-charging circuit directly on pre-charging contactor: <ul style="list-style-type: none"> Frame size HI: 2 x 16 mm² max. (3RT1034) Frame size JI: 2 x 35mm² max. (3RT1044)
PE connection	Connecting thread: <ul style="list-style-type: none"> Frame sizes FI / GI: M10 / 25 Nm for cable lugs in accordance with DIN 46234 / DIN 46235 ¹⁾ Frame sizes HI / JI: M12 / 50 Nm for cable lugs in accordance with DIN 46234 / DIN 46235 ¹⁾

¹⁾ Dimensions for connecting alternative cable lugs, see "cable lugs" in the appendix.

3.6.3.4 DRIVE-CLiQ interface X500

Table 3- 24 DRIVE-CLiQ interface X500

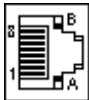
	PIN	Signal name	Technical specifications
	1	TXP	Transmit data +
	2	TXN	Transmit data -
	3	RXP	Receive data +
	4	Reserved, do not use	
	5	Reserved, do not use	
	6	RXN	Receive data -
	7	Reserved, do not use	
	8	Reserved, do not use	
	A	+ (24 V)	24 V power supply
	B	M (0 V)	Electronics ground
Blanking plate for DRIVE-CLiQ interfaces (50 pcs.) Article number: 6SL3066-4CA00-0AA0			

3.6.3.5 X530 neutral point grounding

Table 3- 25 Neutral point grounding X530

	Terminal	Designation	Technical data
1	1	Neutral point of the voltage sensing	Jumper inserted: Grounded measurement Jumper not inserted: isolated measurement
2	2	Ground potential	

The Voltage Sensing Module is supplied with inserted jumper. When delivered, the neutral point is connected to the protective conductor via the connector jumper. Current can flow to PE. This connection is removed by removing the connector jumper. The measurement is then electrically isolated.

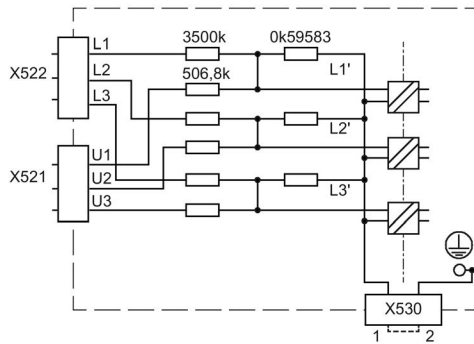
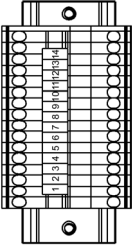

Figure 3-16 Internal circuit of the VSM10 Voltage Sensing Module

When the Active Interface Module is operated on an ungrounded line system (IT system), the connection clip must be removed, see "Electrical connection" (Page 87).

3.6.3.6 X609 terminal strip

Table 3- 26 X609 terminal strip

	Terminal	Designation	Technical specifications		
	1	P24	External 24 V DC supply Voltage: 24 V DC (20.4 ... 28.5 V) Current consumption: Max. 0.25 A		
	2	P24			
	3	M			
	4	M			
	5	L	Voltage: 230 V AC (195.5 ... 264.5 V) Current consumption: Max. 10 A Fan operating currents, see "Technical data"		
	6	L			
	7	N			
	8	N			
	9	Precharge contactor–A1	Voltage: 230 V AC (195.5 ... 264.5 V) Current consumption: Max. 4 A	To Active Line Module, X9:5	
	10	Precharge contactor–A2		To Active Line Module, X9:6	
	11	Bypass contactor–A1	Voltage: 230 V AC (195.5 ... 264.5 V) Current consumption: Max. 6 A	To Active Line Module, X9:3	
	12	Bypass contactor–A2		To Active Line Module, X9:4	
	13	Contactor feedback 1 *	Voltage: 230 V AC (195.5 ... 264.5 V) Max. permissible current: 6 A		
	14	Contactor feedback 2 *			

Max. connectable cross-section: 1.5 mm²

* Series connection NO contact of precharge contactor and bypass contactor (only for frame size FI, GI)

NOTICE
Device failure due to overtemperature caused by incorrect wiring of Active Interface Modules with frame size HI and JI

During operation, Active Interface Modules of frame sizes HI and JI require a signal at terminals X609:11 and X609:12 to control the fans. If this signal is not present during operation, the fans do not rotate and the module is shut down on overtemperature.

- Connect the signals at terminals X609:11 and X609:12 to the Active Interface Modules of frame sizes HI and JI to control the fans.

3.6.3.7 Meaning of the LED on the Voltage Sensing Module (VSM) in the Active Interface Module

Table 3- 27 Description of the LED on the Voltage Sensing Module (VSM) in the Active Interface Module

LED	Color	State	Description
RDY	---	Off	The electronics power supply is missing or out of tolerance.
	Green	Continuous light	The component is ready for operation and cyclic DRIVE-CLiQ communication is taking place.
	Orange	Continuous light	DRIVE-CLiQ communication is being established.
	Red	Continuous light	This component has at least one fault. Remark: The LED is activated irrespective of whether the corresponding messages have been reconfigured.
	Green/red	Flashing 0.5 Hz	Firmware is being downloaded.
		2 Hz flashing light	Firmware download is complete. Waiting for POWER ON.
	Green/orange or red/orange	2 Hz flashing light	Component recognition via LED is activated (p0144). Remark: Both options depend on the LED status when module recognition is activated via p0144 = 1.

3.6.4 Dimension drawing

Dimension drawing, frame size FI

The mandatory cooling clearances are indicated by the dotted line.

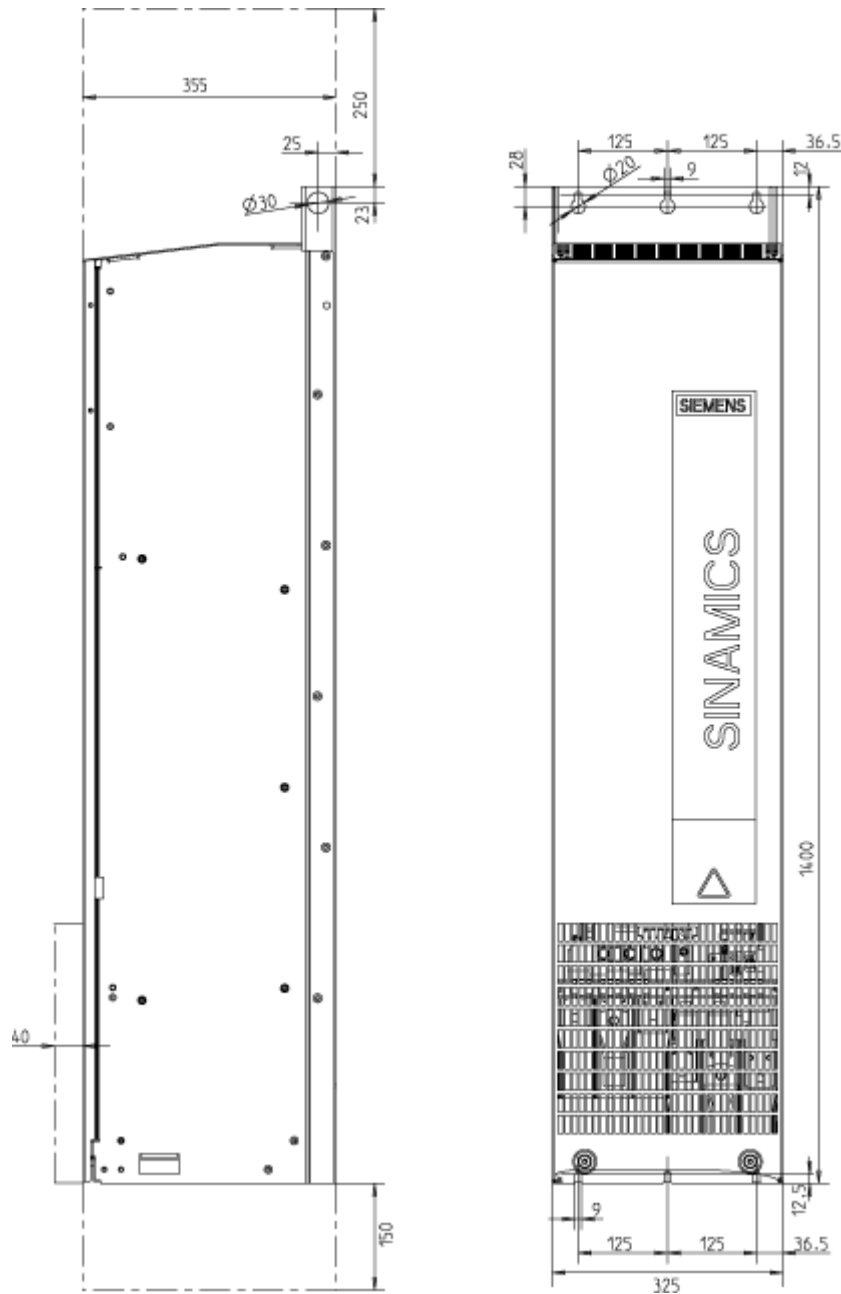

Figure 3-17 Dimension drawing for Active Interface Module, frame size FI Side view, front view

Dimension drawing, frame size GI

The mandatory cooling clearances are indicated by the dotted line.

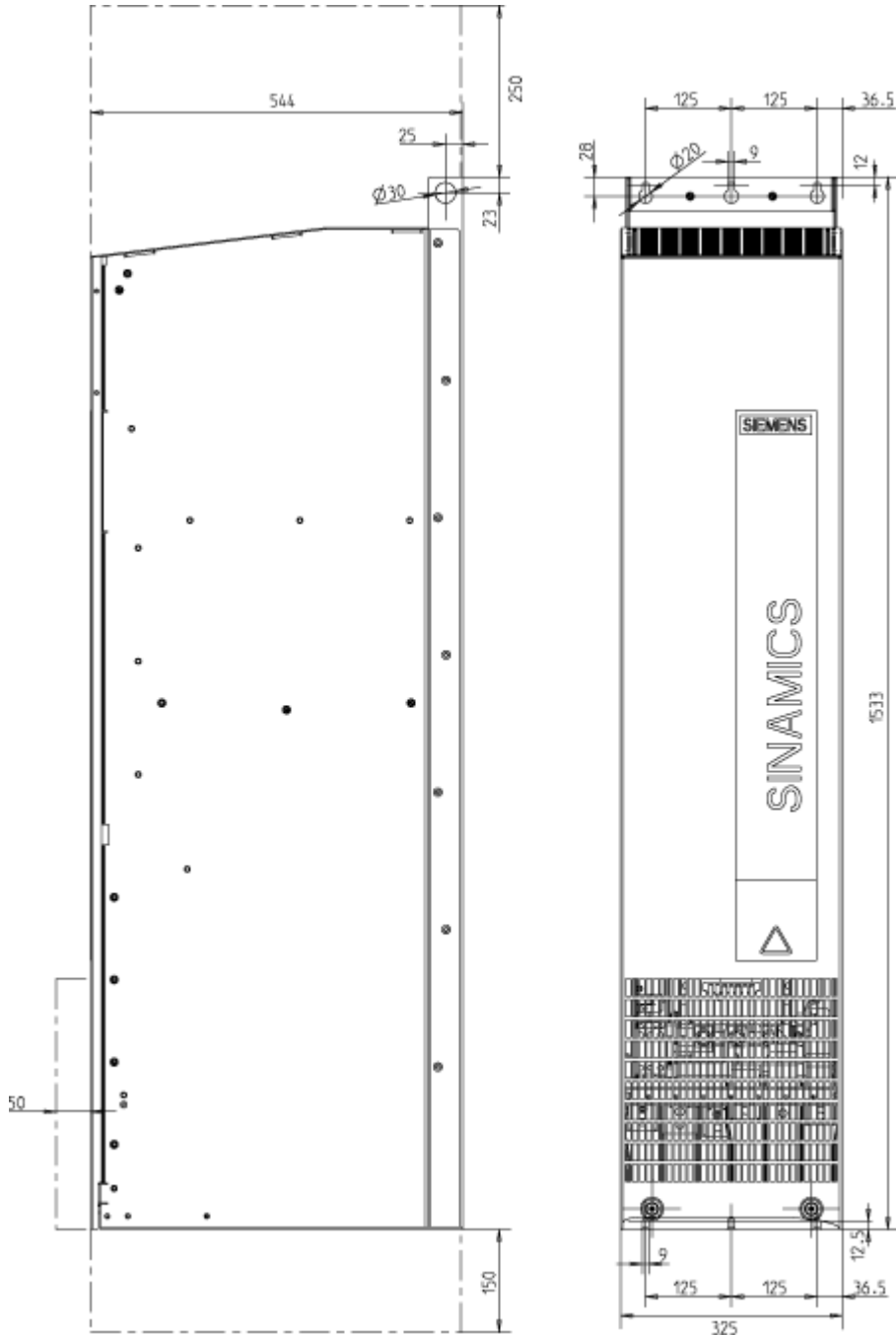

Figure 3-18 Dimension drawing for Active Interface Module, frame size GI Side view, front view

Dimension drawing, frame size HI

The mandatory cooling clearances are indicated by the dotted line.

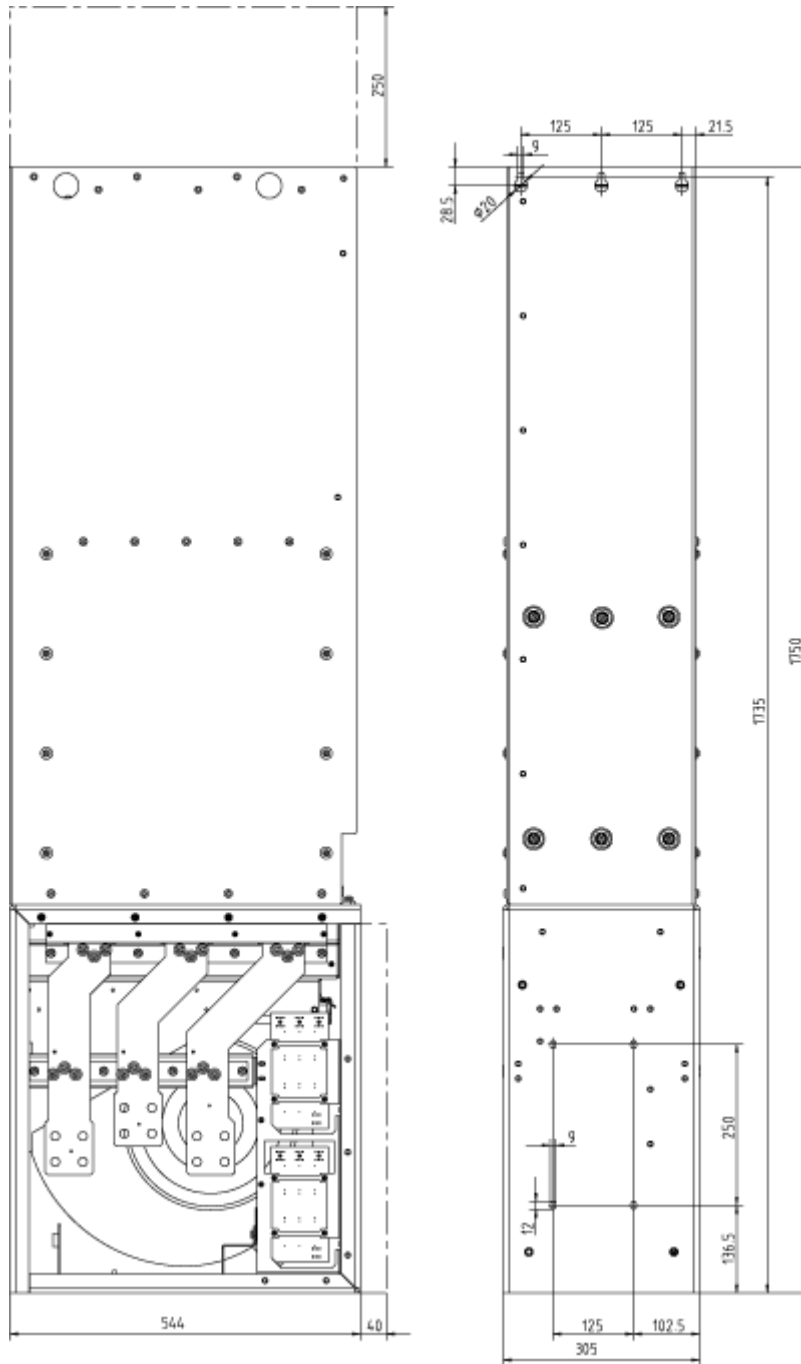

Figure 3-19 Dimension drawing for Active Interface Module, frame size HI Side view, rear view

Dimension drawing, frame size JI

The mandatory cooling clearances are indicated by the dotted line.

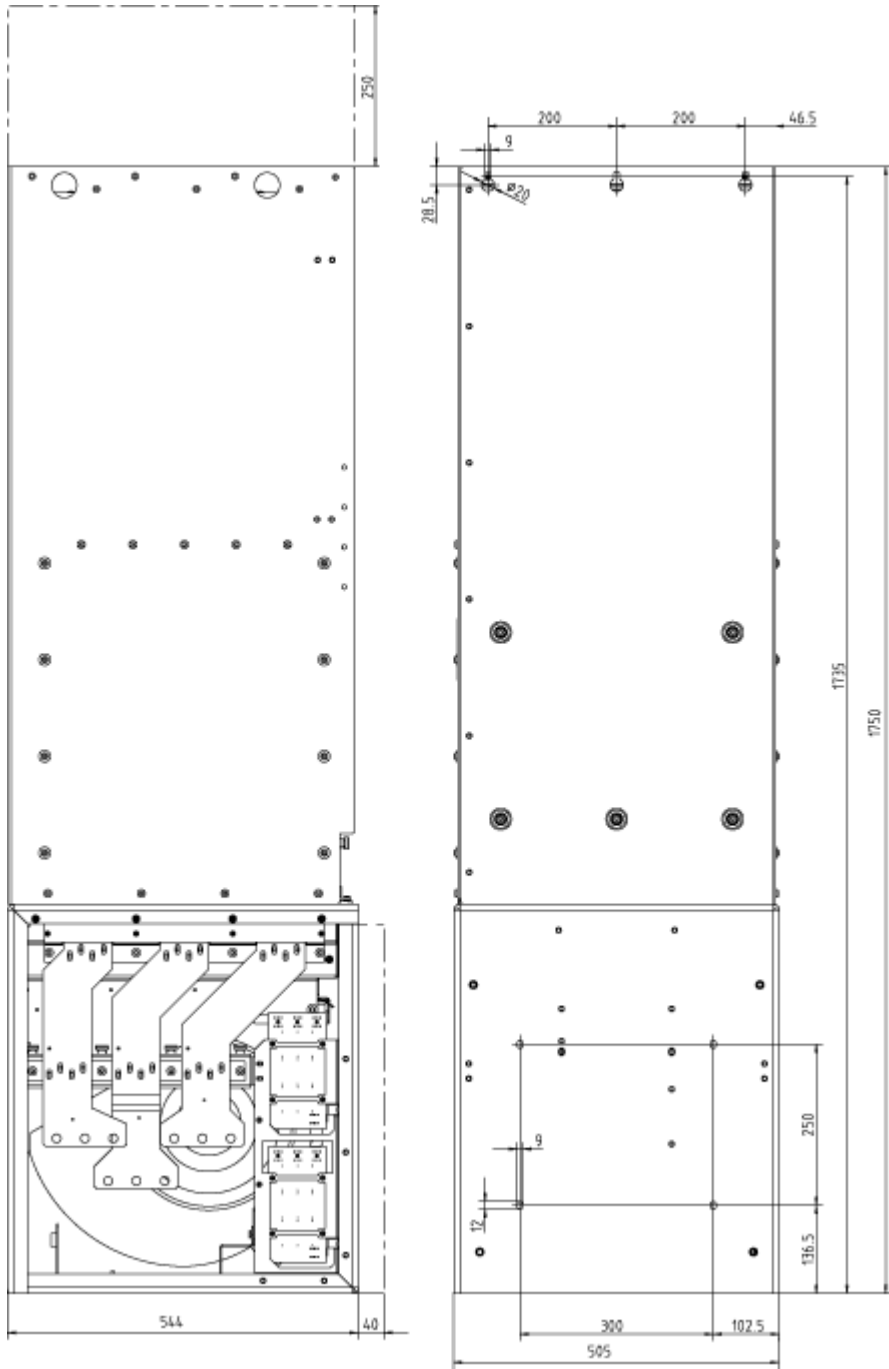

Figure 3-20 Dimension drawing for Active Interface Module, frame size JI Side view, rear view

3.6.5 Electrical connection

The Active Interface Module is electrically connected in accordance with the connection examples shown in section "Interface description".

Operating an Active Interface Module on an ungrounded line supply (IT system)

When the device is operated on an ungrounded line supply (IT system), the integrated basic interference suppression modules must be deactivated by screwing out a connection clip.

Note

Warning label on the connection clip

A yellow warning label is attached to each connection clip so that it is easier to find.

- The warning label must be removed from the connection clip (by pulling it off) if the connection clip is to remain in the unit (operation on a grounded line supply).
 - The warning label must be removed together with the connection clip if the unit is operated on a non-grounded line supply (IT system).
-



Figure 3-21 Warning label on the connection clip

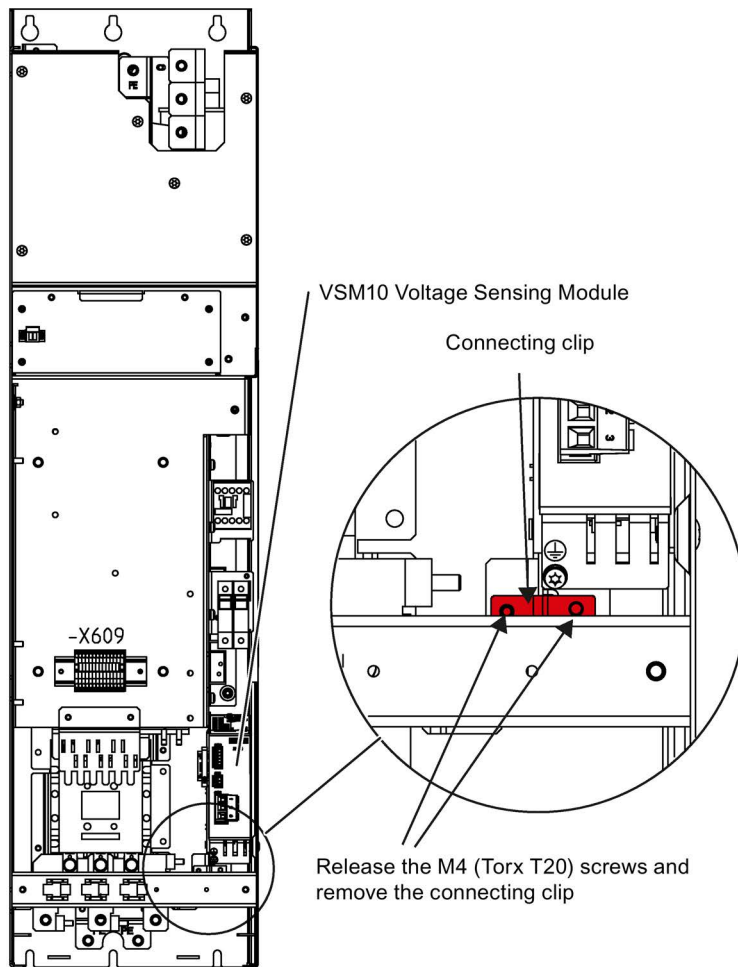

Figure 3-22 Removing the connection clip to the basic interference suppression module in the Active Interface Module for frame size FI

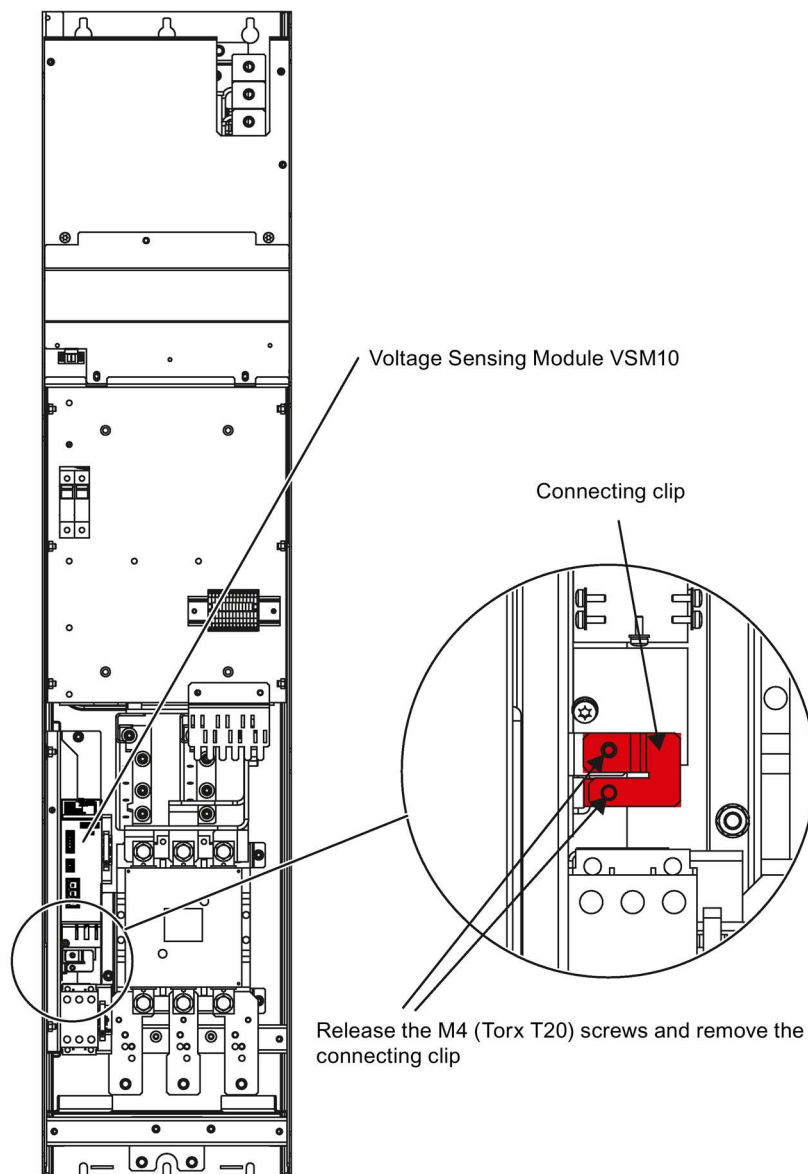

Figure 3-23 Removing the connection clip to the basic interference suppression module in the Active Interface Module for frame size G1

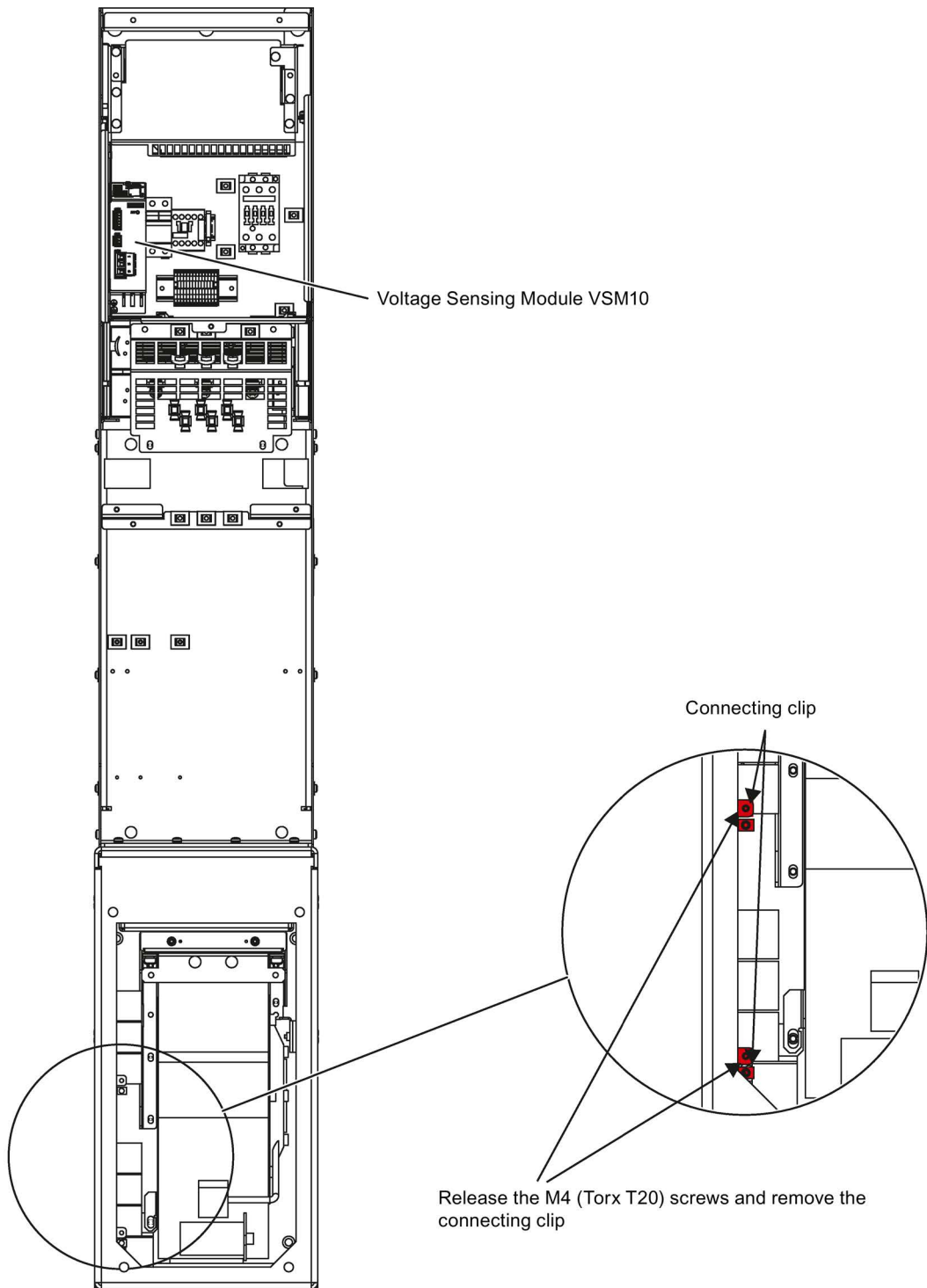

Figure 3-24 Removing the connection clip to the basic interference suppression module in the Active Interface Module for frame size HI

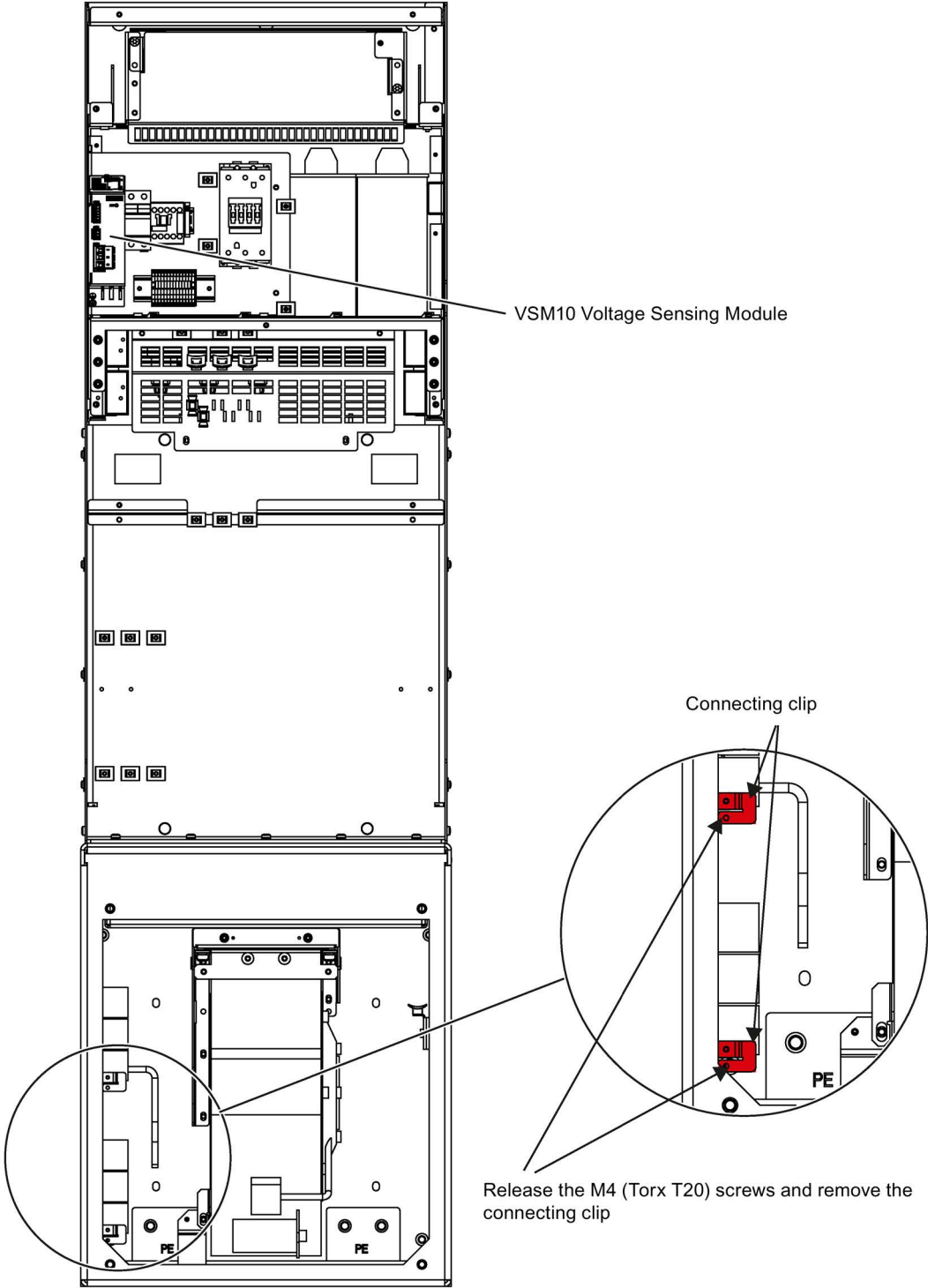



Figure 3-25 Removing the connection clip to the basic interference suppression module in the Active Interface Module for frame size J1

NOTICE
Damage to the device through not removing the connection clip with a non-grounded line supply
Failure to remove the connection clip to the basic interference suppression module on an ungrounded line supply (IT system) can cause significant damage to the device.
<ul style="list-style-type: none">• With a non-grounded line supply (IT system), remove the connection clip to the basic interference suppression module.

Removing the connector jumper on the VSM10 Voltage Sensing Module

When operating the Active Interface Module on an ungrounded line supply (IT system), at the Voltage Sensing Module (VSM10), remove the connector jumper in terminal X530 at the lower side of the component.

Use two screwdrivers or another suitable tool to relieve the holding springs in the terminal and then withdraw the connector jumper.

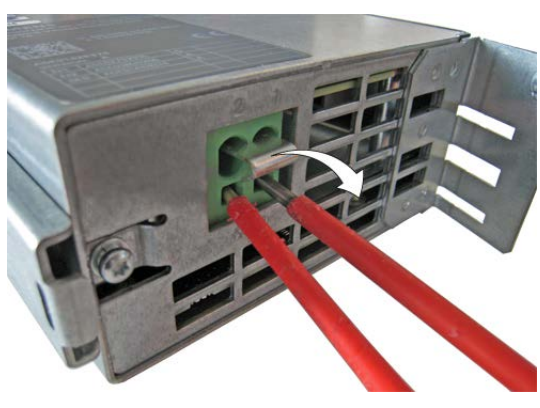
	
Terminal X530 with connector jumper	Relieve the springs and withdraw the connector jumper

3.6.6 Technical data

Table 3- 28 Technical data for Active Interface Modules, 3 AC 380 V ... 480 V, Part 1

Article number	6SL3300-	7TE32-6AAx ¹⁾	7TE32-6AAx ¹⁾	7TE33-8AAx ¹⁾	7TE35-0AAx ¹⁾
Suitable for Active Line Module	6SL3330-	7TE32-1AA3	7TE32-6AA3	7TE33-8AA3	7TE35-0AA3
Rated power of Active Line Module	kW	132	160	235	300
Rated input current of the Active Line Module	A	210	260	380	490
Supply voltages - Line voltage - Line frequency - Electronic power supply - Fan supply voltage	V _{ACrms} Hz V _{DC} V _{AC}	3 AC 380 -10% (-15% < 1 min) ... 3 AC 480 +10% 47 ... 63 Hz 24 (20.4 ... 28.8) 230 (195.5 ... 264.5)			
DC-link capacitance of the drive line-up, max.	µF	41600	41600	76800	76800
Current consumption - Electronics current consumption (24 V DC) - Fan supply, 2 AC 230 V, 50/60 Hz, max. - Max. precharging current (max. 3 s)	A A A	0.17 0.45 / 0.6 57	0.17 0.45 / 0.6 57	0.17 0.9 / 1.2 57	0.17 0.9 / 1.2 57
Bypass contactor		included	included	included	included
Current drawn bypass contactor (230 V AC) - Making current - Holding current	A A	1.25 0.6	1.25 0.6	2.5 1.2	2.5 1.2
Max. ambient temperature - Without derating - With derating	°C °C	40 55	40 55	40 55	40 55
Power loss, max. ²⁾ - at 50 Hz 400 V - at 60 Hz 460 V	kW kW	2.1 2.1	2.2 2.2	3.0 3.0	3.9 3.9
Cooling air requirement	m ³ /s	0.24	0.24	0.47	0.47
Line/load connection L1, L2, L3 / U2, V2, W2		Flat connector for screw			
		M10	M10	M10	M10
PE connection		M10 screw	M10 screw	M10 screw	M10 screw
Line/load connection - Line connection (L1, L2, L3) - Load connection (U2, V2, W2) - PE connection	mm ² mm ² mm ²	2 x 185 2 x 185 2 x 185	2 x 185 2 x 185 2 x 185	2 x 185 2 x 185 2 x 185	2 x 185 2 x 185 2 x 185
Degree of protection		IP20	IP20	IP20	IP20
Dimensions - Width - Height - Depth	mm mm mm	325 1400 355	325 1400 355	325 1533 544	325 1533 544
Frame size		FI	FI	GI	GI
Weight	kg	135	135	190	190

¹⁾ x = 0: with KTY84 temperature sensor, x = 1: with PT1000 temperature sensor.

²⁾ The specified power loss is the maximum value at 100% utilization level. The value in normal operation is lower.

Table 3- 29 Technical data for Active Interface Modules, 3 AC 380 V ... 480 V, Part 2

Article number	6SL3300-	7TE38-4AAx ¹⁾	7TE38-4AAx ¹⁾	7TE41-4AAx ¹⁾	7TE41-4AAx ¹⁾
Suitable for Active Line Module	6SL3330-	7TE36-1AA3	7TE37-5AA3 7TE38-4AA3	7TE41-0AA3	7TE41-2AA3 7TE41-4AA3
Rated power of Active Line Module	kW	380	450 / 500	630	800 / 900
Rated input current of the Active Line Module	A	605	745 / 840	985	1260 / 1405
Supply voltages - Line voltage - Line frequency - Electronic power supply - Fan supply voltage	V _{ACrms} Hz V _{DC} V _{AC}	3 AC 380 -10% (-15% < 1 min) ... 3 AC 480 +10% 47 ... 63 Hz 24 (20.4 ... 28.8) 230 (195.5 ... 264.5)			
DC-link capacitance of the drive line-up, max.	µF	134400	134400	230400	230400
Current consumption - Electronics current consumption (24 V DC) - Fan supply, 2 AC 230 V, 50/60 Hz, max. - Max. precharging current (max. 3 s)	A A A	0.17 3.6 / 4.6 178	0.17 3.6 / 4.6 178	0.17 3.8 / 4.9 178	0.17 3.8 / 4.9 178
Bypass contactor ³⁾		3RT1476-6AP36	3WL1110-2BB34-4AN2-Z Z=C22 ⁴⁾	3WL1112-2BB34-4AN2-Z Z=C22 ⁴⁾	3WL1116-2BB34-4AN2-Z Z=C22 ⁴⁾
Max. ambient temperature - Without derating - With derating	°C °C	40 55	40 55	40 55	40 55
Power loss, max. ²⁾ - at 50 Hz 400 V - at 60 Hz 460 V	kW kW	5.5 5.5	6.1 6.1	7.5 7.5	8.5 8.5
Cooling air requirement	m ³ /s	0.40	0.40	0.40	0.40
Line/load connection L1, L2, L3 / U2, V2, W2		Flat connector for screw			
		M12	M12	M12	M12
PE connection		M12 screw	M12 screw	M12 screw	M12 screw
Line/load connection - Line connection (L1, L2, L3) - Load connection (U2, V2, W2) - PE connection	mm ² mm ² mm ²	4 x 240 4 x 240 2 x 240	4 x 240 4 x 240 2 x 240	6 x 240 6 x 240 4 x 240	6 x 240 6 x 240 4 x 240
Degree of protection		IP00	IP00	IP00	IP00
Dimensions - Width - Height - Depth	mm mm mm	305 1750 544	305 1750 544	505 1750 544	505 1750 544
Frame size		HI	HI	JI	JI
Weight	kg	390	390	480	480

1) x = 0: with KTY84 temperature sensor, x = 1: with PT1000 temperature sensor.

2) The specified power loss is the maximum value at 100% utilization level. The value in normal operation is lower.

3) Bypass contactor is not included, must be provided separately.

4) The circuit breaker is controlled by the sequence control of the Active Line Module, and it is not permissible that it is manually closed. It is therefore recommended that the circuit breaker be equipped with the 3WL9111-0BA21-0AA0 locking set.

Table 3- 30 Technical data for Active Interface Modules, 3 AC 500 V ... 690 V

Article number	6SL3300–	7TG35–8AAx ¹⁾	7TG37–4AAx ¹⁾	7TG41–3AAx ¹⁾	7TG41–3AAx ¹⁾
Suitable for Active Line Module Rated power of Active Line Module	6SL3330-kW	7TG35-8AA3 630	7TG37-4AA3 800	7TG41-0AA3 1100	7TG41-3AA3 1400
Rated input current of the Active Line Module	A	575	735	1025	1270
Supply voltages - Line voltage - Line frequency - Electronic power supply - Fan supply voltage	V _{ACrms} Hz V _{DC} V _{AC}	3 AC 500 -10% (-15% < 1 min) ... 3 AC 690 +10% 47 ... 63 Hz 24 (20.4 ... 28.8) 230 (195.5 ... 264.5)			
DC-link capacitance of the drive line-up, max.	µF	59200	153600	153600	153600
Current consumption - Electronics current consumption (24 V DC) - Fan supply, 2 AC 230 V, - Max. precharging current (max. 3 s)	A A A	0.17 4.6 141	0.17 4.9 141	0.17 4.9 141	0.17 4.9 141
Bypass contactor ³⁾		3RT1476-6AP36	3RT1476-6AP36 (3 x)	3WL1212-4BB34-4AN2-Z Z=C22 ⁴⁾	3WL1216-4BB34-4AN2-Z Z=C22 ⁴⁾
Max. ambient temperature - Without derating - With derating	°C °C	40 55	40 55	40 55	40 55
Power loss, max. ²⁾ - at 50 Hz 690 V - at 60 Hz 575 V	kW kW	6.8 6.8	9.0 9.0	9.2 9.2	9.6 9.6
Cooling air requirement	m ³ /s	0.40	0.40	0.40	0.40
Line/load connection L1, L2, L3 / U2, V2, W2		Flat connector for screw			
		M12	M12	M12	M12
PE connection		M12 screw	M12 screw	M12 screw	M12 screw
Line/load connection - Line connection (L1, L2, L3) - Load connection (U2, V2, W2) - PE connection	mm ² mm ² mm ²	4 x 240 4 x 240 2 x 240	6 x 240 6 x 240 4 x 240	6 x 240 6 x 240 4 x 240	6 x 240 6 x 240 4 x 240
Degree of protection		IP00	IP00	IP00	IP00
Dimensions - Width - Height - Depth	mm mm mm	305 1750 544	505 1750 544	505 1750 544	505 1750 544
Frame size		HI	JI	JI	JI
Weight	kg	390	430	530	530

1) x = 0: with KTY84 temperature sensor, x = 1: with PT1000 temperature sensor.

2) The specified power loss is the maximum value at 100% utilization level. The value in normal operation is lower.

3) Bypass contactor is not included, must be provided separately.

4) The circuit breaker is controlled by the sequence control of the Active Line Module, and it is not permissible that it is manually closed. It is therefore recommended that the circuit breaker be equipped with the 3WL9111-0BA21-0AA0 locking set.

Line Modules

4.1 Introduction

The drive line-up is connected to the power supply network via the Line Modules.

Line Infeeds comprise a Line Module and the associated line connection and generate a DC voltage from the connected line voltage that is used to power the connected Motor Modules.

The Line Modules and Interface Modules are suitable for direct operation on TN, IT and TT systems.

General characteristics of the Line Modules

- Supply voltage:
 - 3 AC 380 V -10% (-15% < 1 min) to 3 AC 480 V +10%
 - 3 AC 500 V -10% (-15% < 1 min) to 3 AC 690 V +10%
- Line frequency: 47 to 63 Hz
- Suitable for TN, TT, and IT supply systems
- Operating status and error status via LEDs

4.2 Basic Line Modules

4.2.1 Description

Basic Line Modules are used for the power infeed into the DC link.

They are suitable for applications in which no regenerative energy is produced, or in which the energy exchange takes place between the motor- and the generator-driven axes in the DC link.

The DC-link voltage is greater than the rms value of the line rated voltage by a factor of 1.35 (under partial load) or 1.32 (under full load).

Table 4- 1 Overview of Basic Line Modules

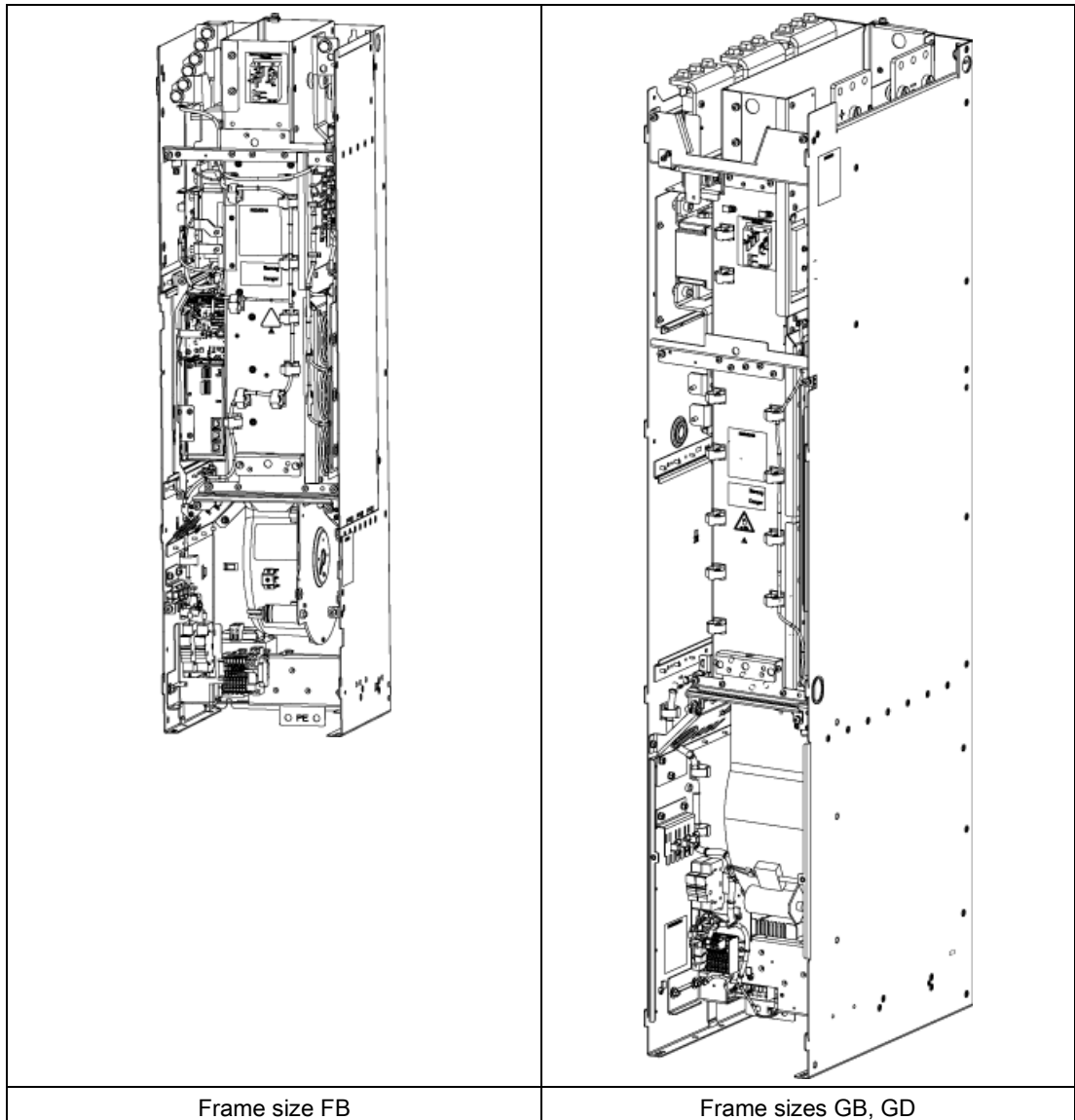

Components of the Basic Infeed

A Basic Infeed comprises a Basic Line Module and an external line connection, which comprises a line filter and a line reactor.

Operating principle

One or more Motor Modules can be connected to the power supply network via the Basic Line Module. The Basic Line Module provides the DC-link voltage for the Motor Modules.

The Basic Line Module is suitable for direct operation both on TN and on IT and TT systems.

Parallel connection of Basic Line Modules to increase power rating

Up to four Basic Line Modules with the same power rating can be connected in parallel in order to increase power.

The following rules must be observed when connecting Basic Line Modules in parallel:

- Up to four identical Basic Line Modules can be connected in parallel.
- A common Control Unit is required whenever the modules are connected in parallel.
- With multiple infeeds, power must be supplied to the systems from a common infeed point (i.e. different supply systems are not permitted).
- A line reactor must be series-connected to every parallel-connected Basic Line Module.
- The upstream line contactors of the individual precharging circuits must switch-on jointly and simultaneously.
- A derating factor of 7.5% must be taken into consideration, regardless of the number of modules connected in parallel.

The following rules must be observed when connecting Basic Line Modules of frame size GD in parallel:

- Each Basic Line Module must be precharged via a separate precharging circuit.
- The circuit breakers of the respective precharging circuits must switch-on jointly and simultaneously; this can be performed via a monitoring function of the circuit breaker feedback signals.

Note

Mixed operation is not possible

It is only possible to connect identical power units in parallel if all power units have the same hardware version. Mixed operation between a power unit with Control Interface Module (article number 6SL33xx-xxxxx-xAA3) and a power unit with Control Interface Board (article number 6SL33xx-xxxxx-xAA0) is not possible.

4.2.2 Safety information

 WARNING
Not observing fundamental safety instructions and residual risks Not observing fundamental safety instructions and residual risks listed in Chapter 1 can result in accidents with severe injuries or death. <ul style="list-style-type: none">• Comply with the fundamental safety instructions.• When assessing the risk, take into account remaining risks.



 DANGER
Electric shock due to a high DC link voltage As long as the Line Module is connected to the line supply, the DC link is charged with a high voltage. Contact with components leads to death or serious injury. <ul style="list-style-type: none">• Isolate the Line Module from the line supply during installation of maintenance work, e.g. via the line contactor or main switch.



 WARNING
Electric shock or fire due to overcurrent protective equipment that trips too late Overcurrent protective devices that do not trip or trip too late can cause an electric shock or fire. <ul style="list-style-type: none">• To protect personnel and for fire protection purposes, at the infeed point, the short-circuit rating and loop impedance must correspond to the specifications in the documentation in order for the installed overcurrent protection devices to trip within the specified time.



 WARNING
High leakage currents when the protective conductor in the line feeder cable is interrupted The drive components conduct a high leakage current via the protective conductor. Touching conductive parts when the protective conductor is interrupted can result in death or serious injury. <ul style="list-style-type: none">• Ensure that the external protective conductor satisfies at least one of the following conditions:<ul style="list-style-type: none">– It has been installed so that it is protected against mechanical damage. ¹⁾– For an individual core, it has a cross-section of at least 10 mm² Cu.– If it is a conductor of a multi-conductor cable, it has a cross-section of at least 2.5 mm² Cu.– It has a second protective conductor in parallel with the same cross-section.– It complies with the local regulations for equipment with increased leakage current. <p>¹⁾ Cables laid within control cabinets or closed machine housings are considered to be adequately protected against mechanical damage.</p>

⚠ WARNING**Fire due to inadequate ventilation clearances**

Inadequate ventilation clearances can cause overheating with a risk for personnel through smoke development and fire. This can also result in more downtimes and reduced service lives of Line Modules.

- Observe the ventilation clearances above, below, and in front of the Line Modules, which are specified in the dimension drawings.

⚠ CAUTION**Fire due to overheating when the total length of the power cables is exceeded**

Overheating and a fire can result when the total length of the power cables is exceeded.

- Ensure that the total length of the power cables (motor feeder cables and DC link cables) does not exceed the values specified in the technical data.

NOTICE**Material damage caused by loose power connections**

Insufficient tightening torques or vibration can result in faulty electrical connections. This can cause fire damage or malfunctions.

- Tighten all power connections with the specified tightening torques, e.g. line supply connection, motor connection, DC link connections.
- Check the tightening torques of all power connections at regular intervals and tighten them when required. This applies in particular after transport.

NOTICE**Damage to the devices when performing a voltage test as a result of connections that are not disconnected**

As part of routine tests, SINAMICS S components undergo a voltage test according to EN 61800-5-1. Connected devices can be damaged.

- Disconnect or unplug all SINAMICS devices before the voltage test of the machine equipment according to EN 60204-1, Section 18.4.

NOTICE**Damage through use of incorrect DRIVE-CLiQ cables**

Damage or malfunctions can occur on the devices or system when DRIVE-CLiQ cables are used that are either incorrect or have not been released for this purpose.

- Only use suitable DRIVE-CLiQ cables that have been released by Siemens for the particular application.

4.2.3 Interface description

4.2.3.1 Overview

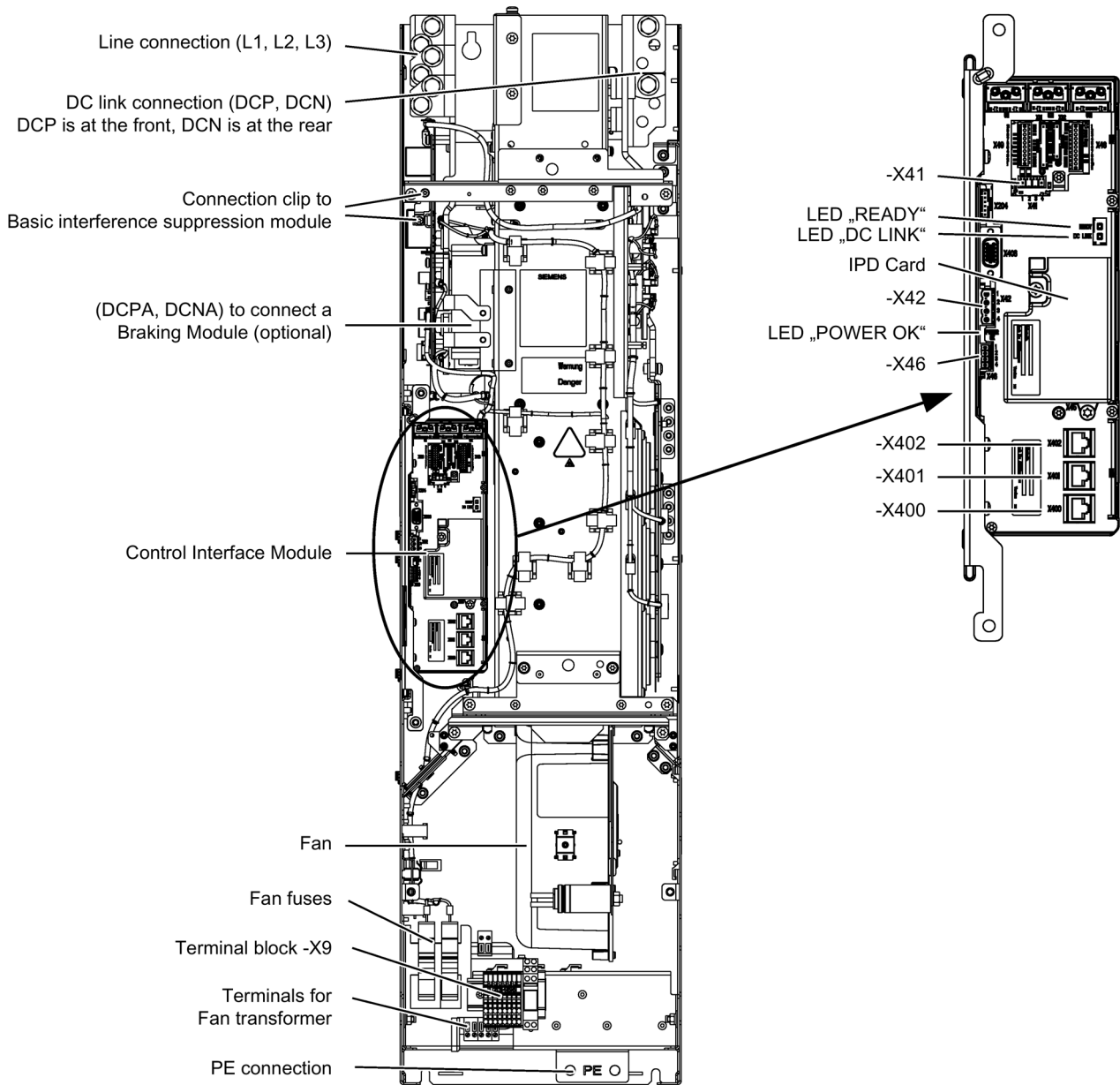

Figure 4-1 Basic Line Module, frame size FB

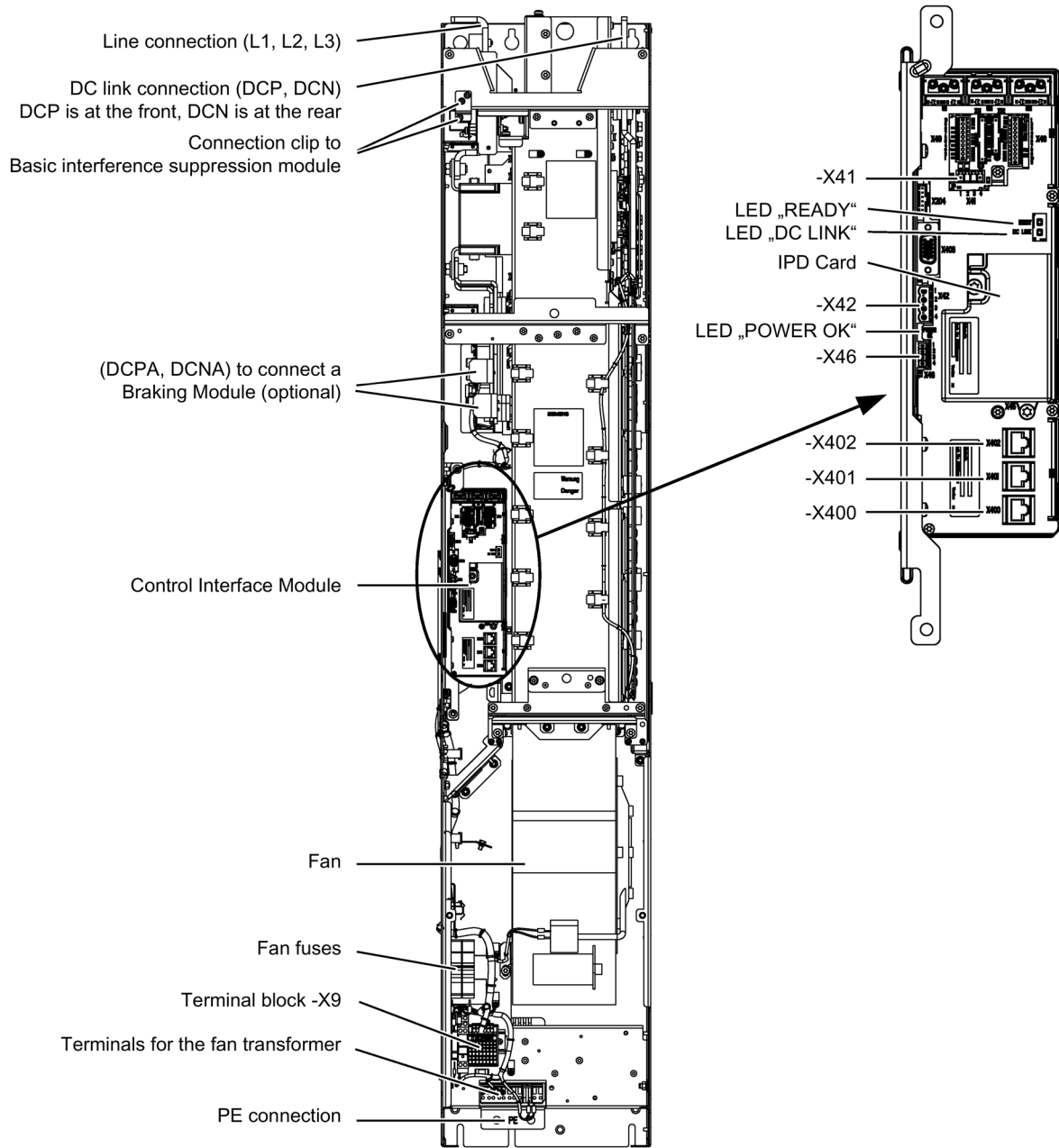

Figure 4-2 Basic Line Module, frame sizes GB, GD

4.2.3.2 Connection example

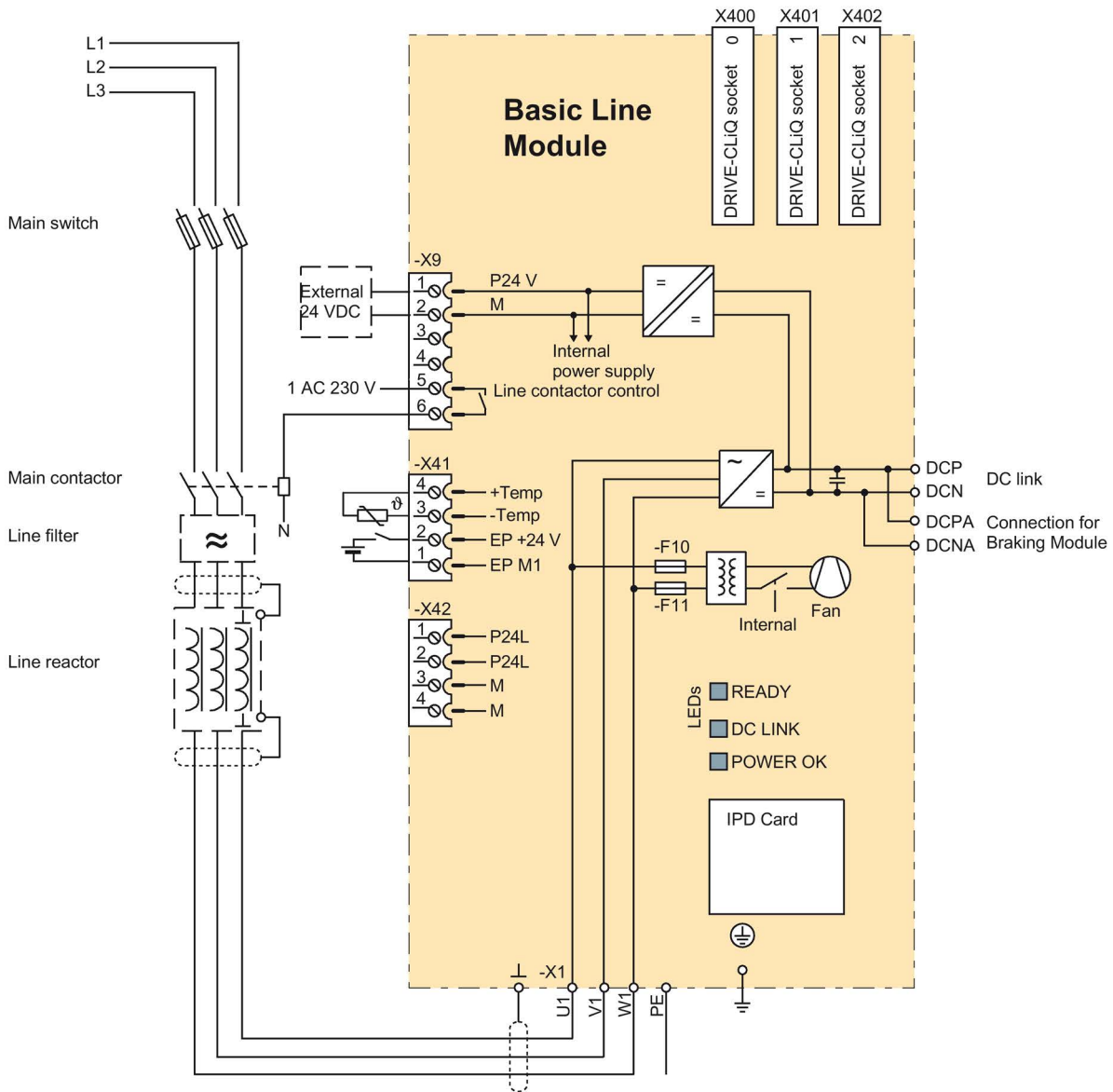

Figure 4-3 Connection example for Basic Line Module, frame sizes FB, GB

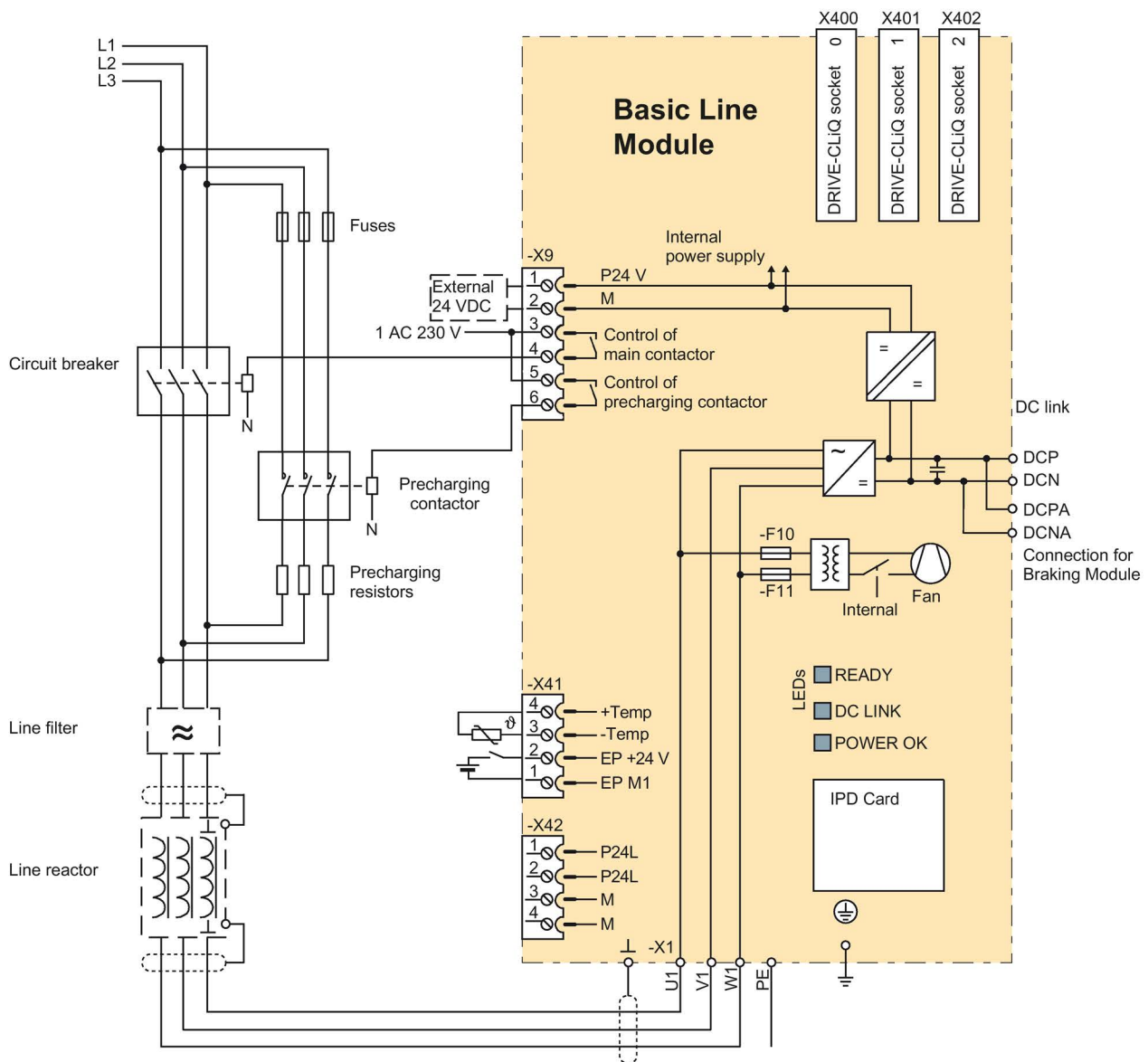

Figure 4-4 Connection example, Basic Line Module, frame size GD

NOTICE

Damage to the device due to different phase sequence in the precharging and main circuits

During the brief overlap period where both contactors are simultaneously closed, the precharging resistors of the Basic Line Module could be overloaded and destroyed due to different phase sequences in the precharging and main circuits.

- Connect the power cables to the precharging and main circuits with the same phase sequence.

4.2.3.3 Line/load connection

Table 4- 2 Line/load connection of the Basic Line Module

Terminals	Technical specifications
U1, V1, W1 3 AC power input	Voltage: <ul style="list-style-type: none"> • 3 AC 380 V -10% (-15% < 1 min) ... 3 AC 480 V +10% • 3 AC 500 V -10% (-15% < 1 min) ... 3 AC 690 V +10% Frequency: 47 ... 63 Hz Connecting thread: <ul style="list-style-type: none"> • Frame size FB: M10 / 25 Nm for cable lugs according to DIN 46234 / DIN 46235 ¹⁾ • Frame sizes GB, GD: M12 / 50 Nm for cable lugs according to DIN 46234 / DIN 46235 ¹⁾
DCPA, DCNA Connection for Braking Module	Voltage: <ul style="list-style-type: none"> • 513 ... 648 V DC • 675 ... 932 V DC Connections: Frame sizes FB, GB, GD: Threaded bolts M6 / 6 Nm for cable lugs according to DIN 46234 / DIN 46235 ¹⁾
DCP, DCN DC power output	Voltage: <ul style="list-style-type: none"> • 513 ... 648 V DC • 675 ... 932 V DC Connecting thread: <ul style="list-style-type: none"> • Frame size FB: M10 / 25 Nm for cable lugs according to DIN 46234 / DIN 46235 ¹⁾ • Frame sizes GB, GD: M12 / 50 Nm for cable lugs according to DIN 46234 / DIN 46235 ¹⁾
PE connection	Connecting thread: <ul style="list-style-type: none"> • Frame size FB: M10 / 25 Nm for cable lugs according to DIN 46234 / DIN 46235 ¹⁾ • Frame sizes GB, GD: M12 / 50 Nm for cable lugs according to DIN 46234 / DIN 46235 ¹⁾

¹⁾ Dimensions for connecting alternative cable lugs, see "cable lugs" in the appendix.

4.2.3.4 X9 terminal strip

Table 4- 3 Terminal strip X9 for Basic Line Modules, frame sizes FB, GB

	Terminal	Signal name	Technical specifications
	1	P24V	External 24 V DC supply Voltage: 24 V DC (20.4 ... 28.8 V) Current consumption: Max. 1.1 A
	2	M	
	3	Reserved, do not use	
	4		
	5	Line contactor control	240 V AC: Max. 8 A 30 V DC: Max. 1 A isolated
	6		
Max. connectable cross-section: 2.5 mm ²			

Table 4- 4 Terminal strip X9 for Basic Line Modules, frame size GD

	Terminal	Signal name	Technical specifications
	1	P24V	External 24 V DC supply Voltage: 24 V DC (20.4 ... 28.8 V) Current consumption: Max. 1.1 A
	2	M	
	3	Line contactor control	240 V AC: Max. 8 A 30 V DC: Max. 1 A isolated
	4		
	5	Precharge contactor control	240 V AC: Max. 8 A 30 V DC: Max. 1 A isolated
	6		
Max. connectable cross-section: 2.5 mm ²			

NOTICE**Damage to the device due to incorrect connection of terminal strip X9**

If the connections for the "Line contactor control" and the "Precharging contactor control" are swapped, the device can be destroyed when it is switched on.

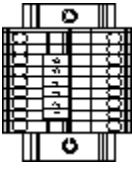
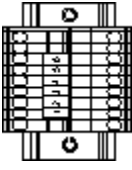
- Note the different connection assignments for terminal strip X9 for the various modules.

4.2.3.5 X41 EP terminal / temperature sensor connection

Table 4- 5 Terminal strip X41

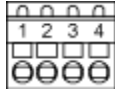
	Terminal	Function	Technical specifications
	1	EP M1 (Enable Pulses)	Supply voltage: 24 V DC (20.4 ... 28.8 V) Current consumption: 10 mA
	2	EP +24 V (Enable Pulses)	
	3	- Temp	Temperature sensor connection KTY84-1C130 / PT1000 / PTC
	4	+ Temp	
Max. connectable cross-section: 1.5 mm ²			



⚠ WARNING

Electric shock in the event of voltage flashovers at the temperature sensor

Voltage flashovers in the signal electronics can occur in motors without safe electrical separation of the temperature sensors.

- Only use temperature sensors that fully comply with the specifications of the safety isolation.
- If safe electrical separation cannot be guaranteed (for linear motors or third-party motors, for example), use a Sensor Module External (SME120 or SME125) or Terminal Module TM120.

NOTICE

Device failure as a result of unshielded or incorrectly routed cables to temperature sensors

Unshielded or incorrectly routed cables to temperature sensors can result in interference being coupled into the signal processing electronics from the power side. This can result in significant disturbance of all signals (fault messages) up to failure of individual components (destruction of the devices).

- Only use shielded cables as temperature sensor cables.
- If temperature sensor cables are routed together with the motor cable, use separately shielded cables twisted in pairs.
- Connect the cable shield to ground potential through a large surface area.
- Recommendation: Use the appropriate MOTION-CONNECT cables.

NOTICE

Damage to motor in the event of incorrectly connected KTY temperature sensor

If a KTY temperature sensor is connected with incorrect polarity, it is not possible to detect when the motor overheats. Overheating can cause damage to the motor.

- Connect a KTY temperature sensor with the correct polarity.

Note

The temperature sensor connection can be used for motors that are equipped with a KTY84-1C130, PT1000 or PTC measuring sensor in the stator windings.

Note**Connection to terminals 1 and 2**

For operation, 24 V DC must be connected to terminal 2 and ground to terminal 1. Pulse suppression is activated when removed.

4.2.3.6 X42 terminal strip

Table 4- 6 Terminal strip X42 voltage supply for Control Unit, Sensor Module and Terminal Module

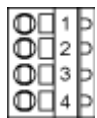
	Terminal	Function	Technical specifications
	1	P24L	Voltage supply for Control Unit, Sensor Module and Terminal Module (18 to 28.8 V) maximum load current: 3 A
	2		
	3	M	
	4		
Max. connectable cross-section: 2.5 mm ²			

Note**Connection options for terminal strip X42**

The terminal strip is not intended for free 24 V DC availability (for example for supplying further line-side components), as the voltage supply of the Control Interface Module could also be overloaded and operating capability could thus be compromised.

4.2.3.7 DRIVE-CLiQ interfaces X400, X401, X402

Table 4- 7 DRIVE-CLiQ interfaces X400, X401, X402

	PIN	Signal name	Technical specifications
	1	TXP	Transmit data +
	2	TXN	Transmit data -
	3	RXP	Receive data +
	4	Reserved, do not use	
	5	Reserved, do not use	
	6	RXN	Receive data -
	7	Reserved, do not use	
	8	Reserved, do not use	
	A	+ (24 V)	24 V power supply
	B	M (0 V)	Electronics ground
Blanking plate for DRIVE-CLiQ interfaces (50 pcs.) Article number: 6SL3066-4CA00-0AA0			

4.2.3.8 Meaning of the LEDs on the Control Interface Module in the Basic Line Module

Table 4- 8 Meaning of the LEDs "READY" and "DC LINK" on the Control Interface Module in the Basic Line Module

LED state		Description
READY	DC LINK	
Off	Off	The electronics power supply is missing or out of tolerance.
Green	--- ¹⁾	The component is ready for operation and cyclic DRIVE-CLiQ communication is taking place.
	Orange	The component is ready for operation and cyclic DRIVE-CLiQ communication is taking place. The DC-link voltage is present.
	Red	The component is ready for operation and cyclic DRIVE-CLiQ communication is taking place. The DC link voltage lies outside the permitted tolerance range.
Orange	Orange	DRIVE-CLiQ communication is being established.
Red	--- ¹⁾	This component has at least one fault. Remark: The LED is activated irrespective of whether the corresponding messages have been reconfigured.
Flashing light 0.5 Hz: green/red	--- ¹⁾	Firmware is being downloaded.
Flashing light 2 Hz: green/red	--- ¹⁾	Firmware download is complete. Waiting for POWER ON.
Flashing light 2 Hz: green/orange or red/orange	--- ¹⁾	Detection of the components via LED is activated (p0124). Note: Both options depend on the LED status when module recognition is activated via p0124 = 1.

¹⁾ Irrespective of the status of the LED "DC LINK"

Table 4- 9 Meaning of the LED "POWER OK" on the Control Interface Module in the Basic Line Module

LED	Color	Status	Description
POWER OK	Green	Off	DC link voltage or control voltage at -X9 too low.
		On	The component is ready for operation.
		Flashing light	There is a fault. If the LED continues to flash after you have performed a POWER ON, please contact your Siemens service center.



WARNING

Electric shock when live parts of the DC link are touched

Hazardous DC link voltages may be present at any time regardless of the status of the "DC LINK" LED. This means that when live parts are touched, this can result in death or serious injury.

- Observe the warning information on the component.

4.2.4 Dimension drawing

Dimension drawing, frame size FB

The mandatory ventilation clearances are indicated by the dotted line.

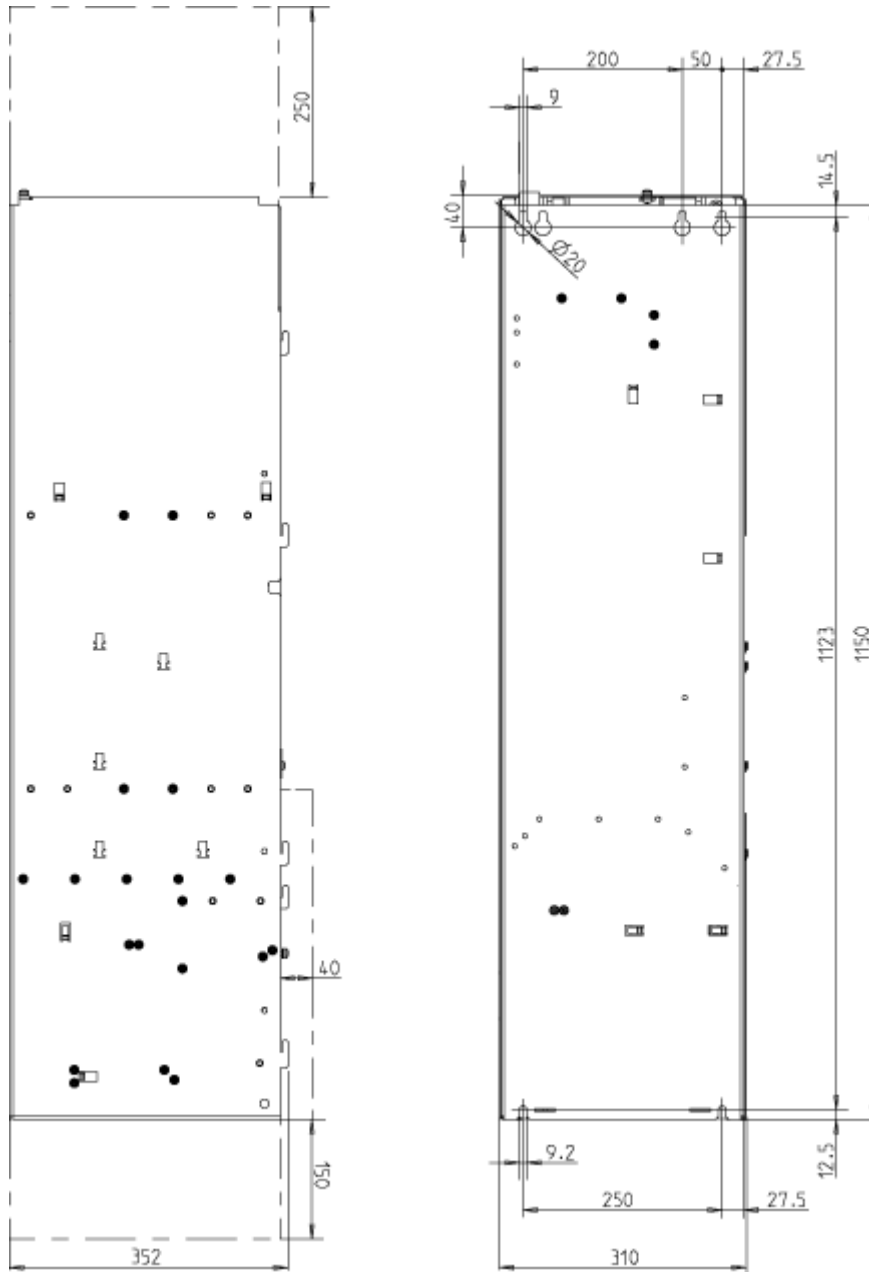

Figure 4-5 Dimension drawing, Basic Line Module, frame sizes FB, side view, front view

Dimension drawing, frame sizes GB, GD

The mandatory ventilation clearances are indicated by the dotted line.

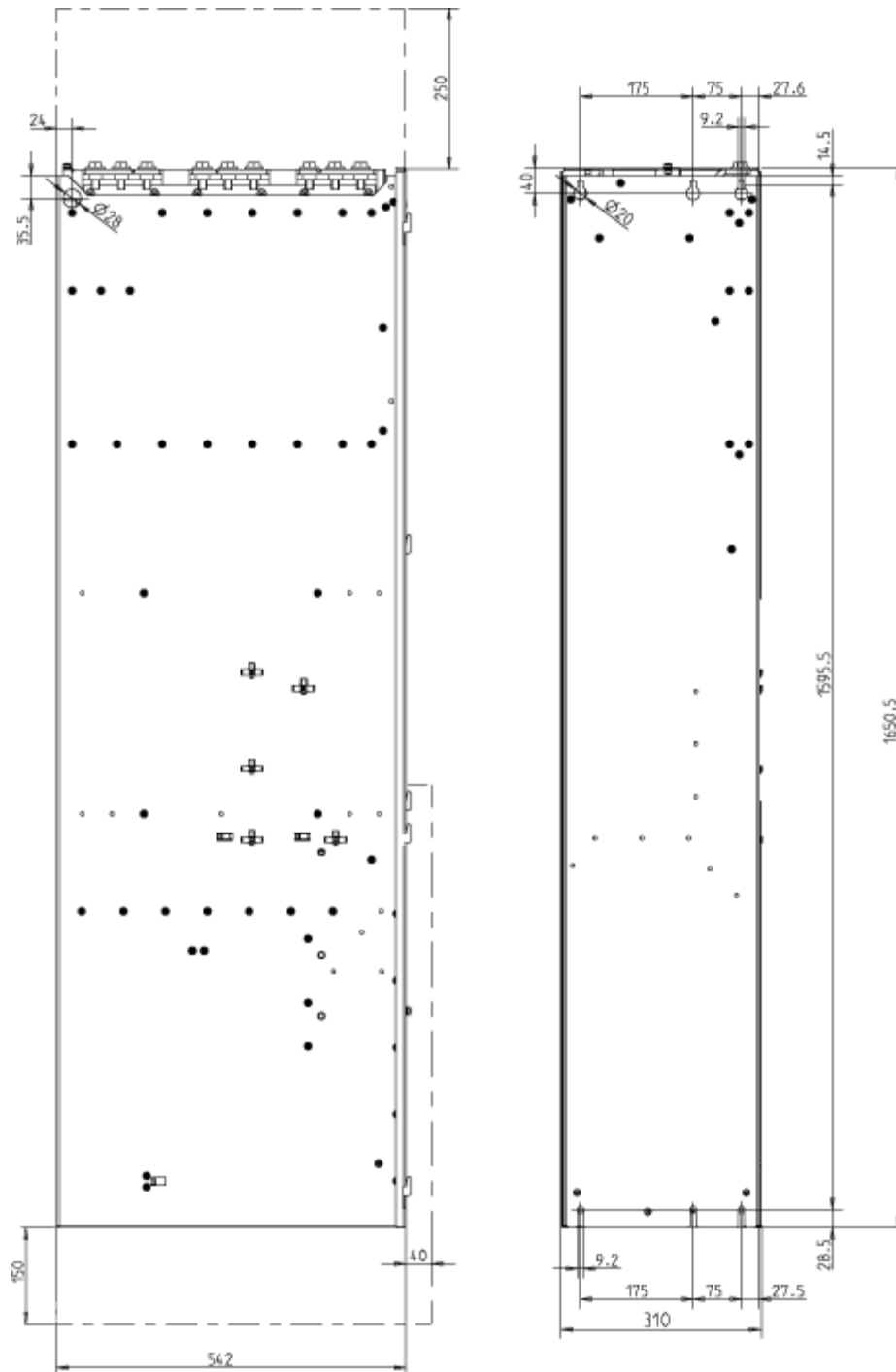

Figure 4-6 Dimension drawing, Basic Line Module, frame sizes GB, GD. Side view, rear view

4.2.5 Electrical connection

Operating a Basic Line Module on a non-grounded line supply (IT system)

When the Basic Line Module is operated on an ungrounded line supply (IT system), the integrated basic interference suppression modules must be deactivated by screwing out a connection clip.

Note

Warning label on the connection clip

A yellow warning label is attached to each connection clip so that it is easier to find.

- The warning label must be removed from the connection clip (by pulling it off) if the connection clip is to remain in the unit (operation on a grounded line supply).
- The warning label must be removed together with the connection clip if the unit is operated on a non-grounded line supply (IT system).



Figure 4-7 Warning label on the connection clip

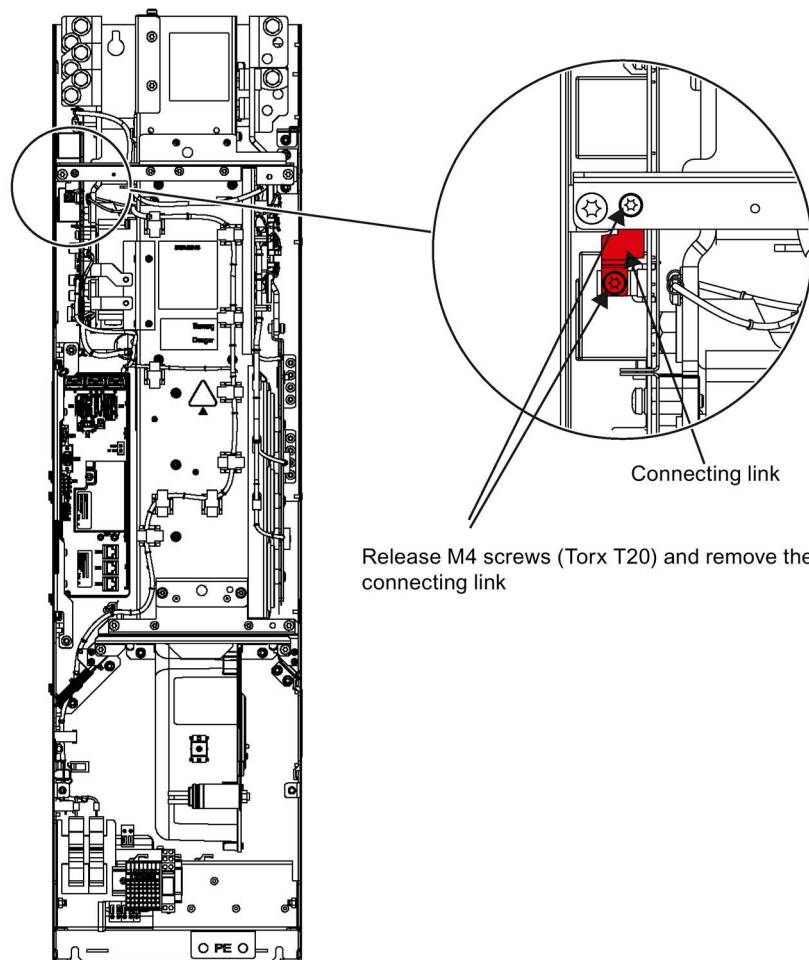

Figure 4-8 Removing the connection clip to the basic interference suppression module in the Basic Line Module, frame size FB

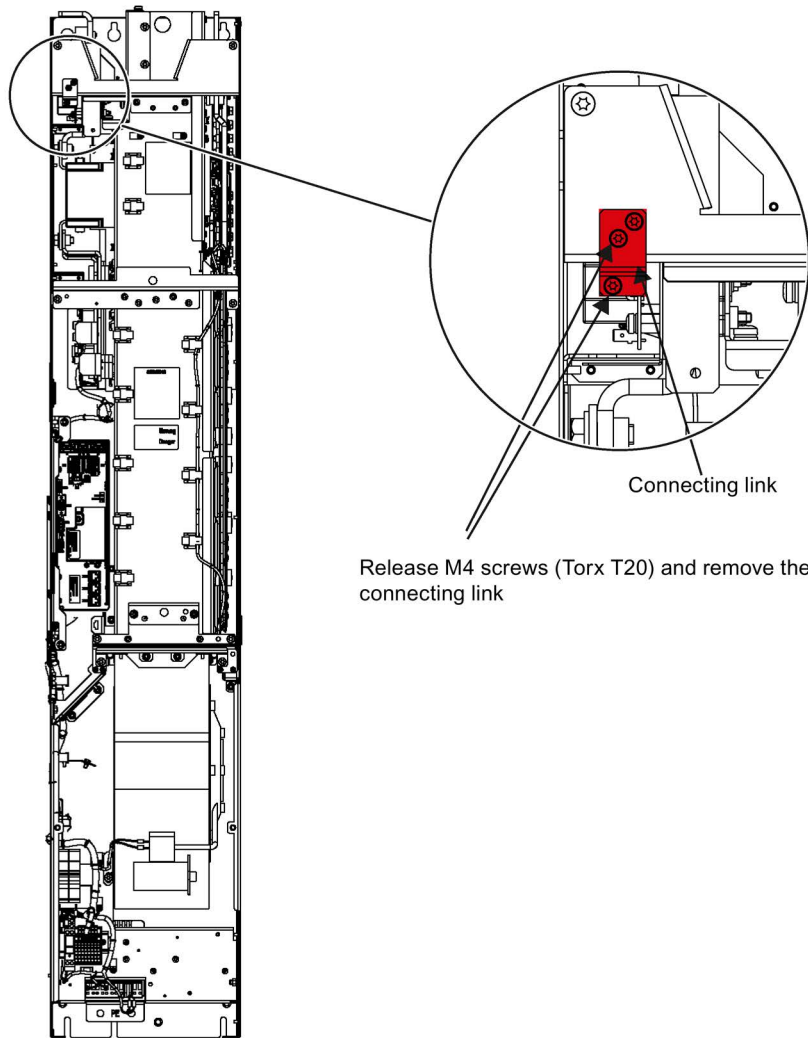

Figure 4-9 Removing the connection clip to the basic interference suppression module in the Basic Line Module, frame sizes GB, GD

<p>NOTICE</p> <p>Damage to the device through not removing the connection clip with a non-grounded line supply</p> <p>Failure to remove the connection clip to the basic interference suppression module on an ungrounded line supply (IT system) can cause significant damage to the device.</p> <ul style="list-style-type: none">• With a non-grounded line supply (IT system), remove the connection clip to the basic interference suppression module.

Adjusting the fan voltage (-T10)

The power supply for the device fans (1 AC 230 V) in the Basic Line Module (-T10) is taken from the line supply using transformers. The installation position of the transformers is indicated in the interface descriptions.

The transformers are fitted with primary taps so that they can be fine-tuned to the line supply voltage.

If necessary, the connection fitted in the factory, shown with a dashed line, must be reconnected to the actual line voltage.

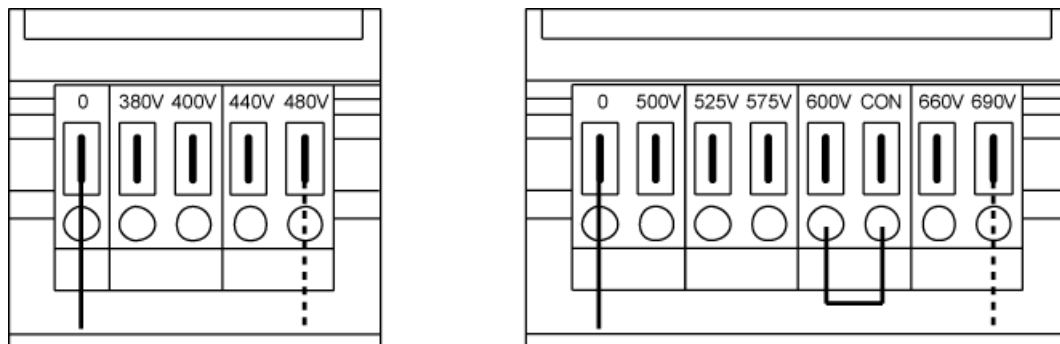

Figure 4-10 Setting terminals for the fan transformers (3 AC 380 to 480 V / 3 AC 500 to 690 V)

The supply voltage assignments for making the appropriate setting on the fan transformer are indicated in the following tables (factory presetting: 480 V / 0 V or 690 V / 0 V).

Note

With the 3 AC 500 V to 690 V fan transformer, a jumper is inserted between the "600 V" terminal and "CON" terminal. The "600 V" and "CON" terminals are for internal use.

WARNING

Fire due to overheating resulting from insufficient equipment fan voltage

If the terminals are not reconnected to the actual line voltage, overheating and human danger due to smoke and fire may result.

This can also cause the fan fuses to blow due to overload.

- Set the terminals in accordance with the actual line voltage.

Table 4- 10 Line voltage assignment for the setting at the fan transformer (3 AC 380 ... 480 V)

Line voltage	Tap at the fan transformer (-T10)
380 V \pm 10%	380 V
400 V \pm 10%	400 V
440 V \pm 10%	440 V
480 V \pm 10%	480 V

Table 4- 11 Line voltage assignment for the setting at the fan transformer (3 AC 500 ... 690 V)

Line voltage	Tap at the fan transformer (-T10)
500 V \pm 10%	500 V
525 V \pm 10%	525 V
575 V \pm 10%	575 V
600 V \pm 10%	600 V
660 V \pm 10%	660 V
690 V \pm 10%	690 V

4.2.6 Precharging circuit for the Basic Line Modules, frame size GD

Description

When switching on, the precharging circuit ensures that the DC-link capacitors of the Basic Line Module and the connected Motor Modules are precharged with current limiting.

After precharging has been completed, the circuit breaker is closed and the precharging circuit bypassed; the Basic Line Module is then directly connected to the line supply.

The precharging circuit comprises a precharging contactor and precharging resistors; the circuit must be protected against overcurrent using suitable protection measures.

To increase the permissible DC-link capacitance, the precharging resistors can also be connected in parallel in each phase.

NOTICE

Damage to the units if the precharging circuit is faulty

When it is switched on, the Basic Line Module can be destroyed if the precharging circuit is not correctly implemented.

- For Basic Line Modules, frame size GD, the precharging input circuit must be implemented according to the following circuit and the notes for dimensioning the various components.

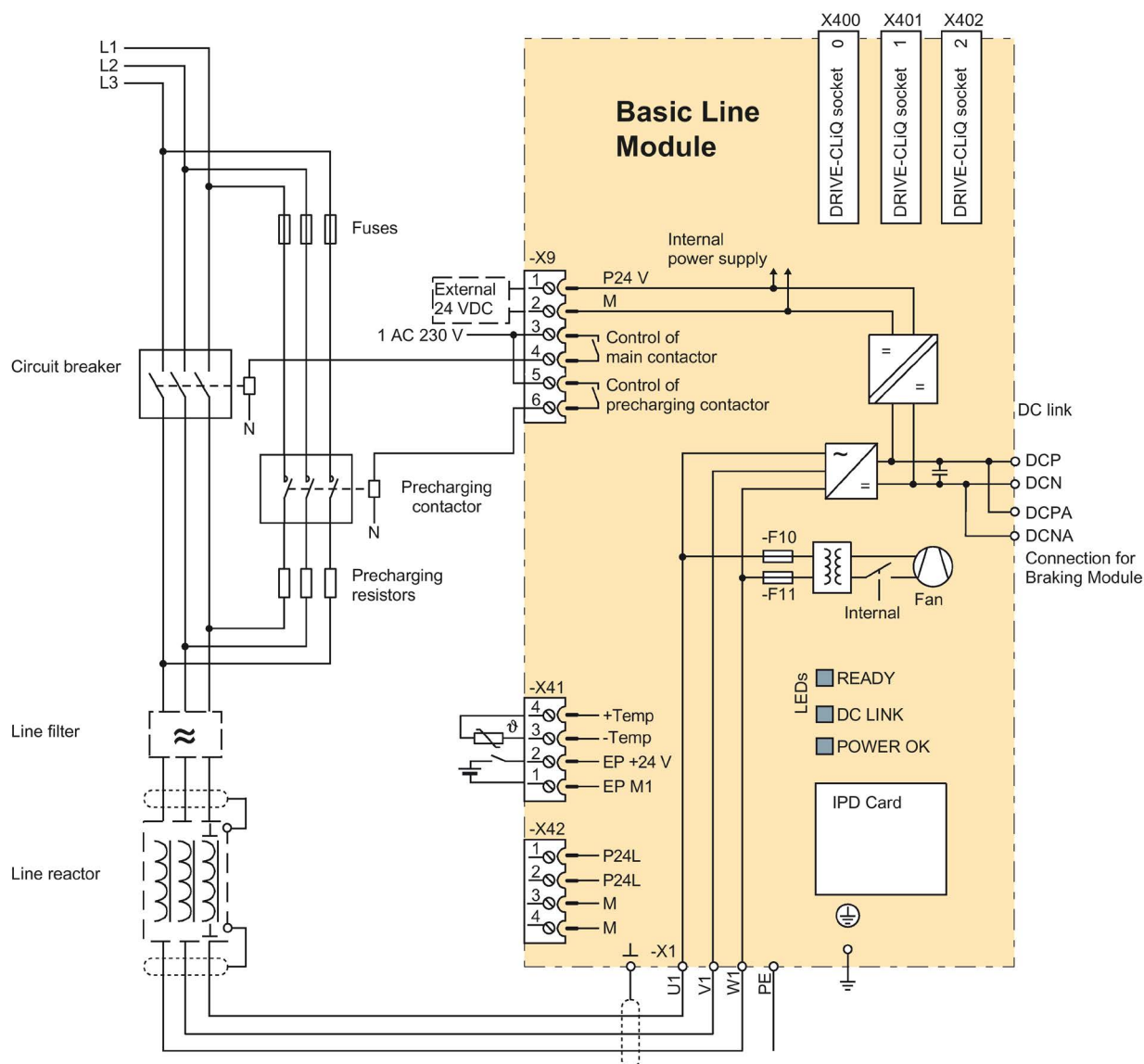

Figure 4-11 Connection example, Basic Line Module, frame size GD

Precharging contactor

The precharging contactor must be able to conduct the maximum precharging current for approx. 1 second (see the technical data) - and be able to switch ohmic-capacitive loads.

To protect against overvoltage when opening, the contactor should be equipped with a varistor, corresponding to the manufacturer's recommendations.

The precharging contactor is controlled via terminal -X9: 5, 6 of the Basic Line Module.

In a version with one precharging resistor for each phase, a contactor of the Sirius 3RT1034 series is recommended.

In a version with two precharging resistors connected in parallel for each phase, a contactor of the Sirius 3RT1044 series is recommended.

Precharging resistors

The precharging resistors are used to limit the current while precharging.

Table 4- 12 Technical data for the precharging resistors

Category	Unit	3 AC 380 ... 480 V	3 AC 500 ... 690 V
Rated voltage	V	690 V AC	690 V AC
Frequency	Hz	47 ... 63	47 ... 63
Resistance value	Ω	2.2 \pm 10%	4.0 \pm 10%
Pulse energy ¹⁾	Ws	18000	18000
Precharging current ²⁾			
- one resistor per phase	A	91	86
- two resistors per phase	A	182	172
Ambient temperature	$^{\circ}$ C	60	60
Article number		6SL3000-0KE12-2AA0	6SL3000-0KH14-0AA0

¹⁾ The pulse energy may only occur every 3 minutes

²⁾ Line current present at the start of the precharging (initial rms value)

As the precharging resistors can get hot, sufficient cooling and clearance to adjacent components must be ensured in operation.

Fuses

The precharging circuit components are protected against overload using fuses.

In a version with one precharging resistor for each phase, fuses of the 3NE1 817-0 (50 A) type are recommended.

In a version with two precharging resistors connected in parallel for each phase, fuses of the 3NE1 021-0 (100 A) type are recommended.

Circuit breaker

The circuit breaker is used to connect to the line supply.

A 3WL1220 circuit breaker is recommended.

The circuit breaker is controlled via terminal -X9: 3, 4 of the Basic Line Module.

4.2.7 Technical data

Table 4- 13 Technical data for Basic Line Modules, 3 AC 380 V ... 480 V, Part 1

Article number	6SL3330-	1TE34-2AA3	1TE35-3AA3	1TE38-2AA3	1TE41-2AA3
Rated output					
- For I_{n_DC} (50 Hz, 400 V)	kW	200	250	400	560
- For I_{H_DC} (50 Hz, 400 V)	kW	160	200	315	450
- For I_{n_DC} (60 Hz, 460 V)	HP	305	385	615	860
- For I_{H_DC} (60 Hz, 460 V)	HP	245	305	485	690
DC-link current					
- Rated current I_{n_DC}	A	420	530	820	1200
- Base load current I_{H_DC}	A	328	413	640	936
- Maximum current I_{max_DC}	A	630	795	1230	1800
Input current					
- Rated current I_{n_E}	A	365	460	710	1010
- Maximum current I_{max_E}	A	547	690	1065	1515
- Maximum precharging current (max. 3 s)	A	internal	internal	internal	internal
Supply voltages		3 AC 380 -10% (-15% < 1 min) ... 3 AC 480 +10% 47 ... 63 Hz 24 (20.4 ... 28.8) 230 (195.5 ... 264.5) 1.35 x U_{line} (partial load) / 1.32 x U_{line} (full load)			
- Line voltage	V_{ACrms}				
- Line frequency	Hz				
- Electronic power supply	V_{DC}				
- Fan supply voltage	V_{AC}				
- DC-link voltage	V_{DC}				
Current consumption					
- Electronics current consumption (24 V DC)	A	1.1	1.1	1.1	1.1
- Fan power consumption (230 V AC)	A	1.1	1.1	1.1	4.5
Max. ambient temperature					
- Without derating	°C	40	40	40	40
- With derating	°C	55	55	55	55
DC-link capacitance					
- Basic Line Module	μF	7200	9600	14600	23200
- Drive line-up, max.	μF	57600	76800	116800	185600
Power loss, max. ¹⁾					
- at 50 Hz 400 V	kW	1.9	2.1	3.2	4.6
- at 60 Hz 460 V	kW	1.9	2.1	3.2	4.6
Cooling air requirement	m^3/s	0.17	0.17	0.17	0.36
Sound pressure level					
L_{pA} (1 m) at 50/60 Hz	dB(A)	66 / 68	66 / 68	66 / 68	71 / 73
Line/load connection		Flat connector for screw			
		M10	M10	M10	M12
Max. connection cross-sections					
- Line connection (U1, V1, W1)	mm^2	2 x 240	2 x 240	2 x 240	6 x 185
- DC-link connection (DCP, DCN)	mm^2	2 x 240	2 x 240	2 x 240	6 x 185
- PE connection	mm^2	2 x 240	2 x 240	2 x 240	4 x 240
Max. cable length (total of all motor cables and DC link)					
- Shielded	m	2600	2600	2600	4000
- Unshielded	m	3900	3900	3900	6000

Article number	6SL3330-	1TE34-2AA3	1TE35-3AA3	1TE38-2AA3	1TE41-2AA3
Degree of protection		IP00	IP00	IP00	IP00
Dimensions					
- Width	mm	310	310	310	310
- Height	mm	1164	1164	1164	1653
- Depth	mm	352	352	352	550
Frame size		FB	FB	FB	GB
Weight	kg	96	96	96	214
Recommended fuse ²⁾					
- Number per phase (connected in parallel)		3NE1333-2 1	3NE1334-2 1	3NE1438-2 1	3NE1435-2 2
- Rated current		450	500	800	560
- Frame size acc. to IEC 60269		2	3	3	3
Minimum short-circuit current ³⁾	A	4400	5200	10000	12400

- 1) The specified power loss is the maximum value at 100% capacity utilization. The value in normal operation is lower.
- 2) To achieve a UL-approved system, it is absolutely essential to use the fuse types specified in the table.
- 3) Minimum current required for reliable triggering of the protective devices.

Table 4- 14 Technical data for Basic Line Modules, 3 AC 380 V ... 480 V, Part 2

Article number	6SL3330-	1TE41-5AA3	1TE41-8AA3		
Rated output					
- For I_{n_DC} (50 Hz, 400 V)	kW	710	900		
- For I_{H_DC} (50 Hz, 400 V)	kW	560	705		
- For I_{n_DC} (60 Hz, 460 V)	HP	1090	1390		
- For I_{H_DC} (60 Hz, 460 V)	HP	860	1090		
DC-link current					
- Rated current I_{n_DC}	A	1500	1880		
- Base load current I_{H_DC}	A	1170	1467		
- Maximum current I_{max_DC}	A	2250	2820		
Input current					
- Rated current I_{n_E}	A	1265	1630		
- Maximum current I_{max_E}	A	1897	2380		
- Maximum precharging current (max. 3 s)	A	internal	308		
Supply voltages		3 AC 380 -10% (-15% < 1 min) ... 3 AC 480 +10%			
- Line voltage	V_{ACrms}	47 ... 63 Hz			
- Line frequency	Hz	24 (20.4 ... 28.8)			
- Electronic power supply	V_{DC}	230 (195.5 ... 264.5)			
- Fan supply voltage	V_{AC}	1.35 x U_{line} (partial load) / 1.32 x U_{line} (full load)			
- DC-link voltage	V_{DC}				
Current consumption					
- Electronics current consumption (24 V DC)	A	1.1	1.1		
- Fan power consumption (230 V AC)	A	4.5	4.5		
Max. ambient temperature					
- Without derating	°C	40	40		
- With derating	°C	55	55		
DC-link capacitance					
- Basic Line Module	μF	29000	34800		
- Drive line-up, max.	μF	232000	139200/278400 ⁴⁾		
Power loss, max. ¹⁾					
- at 50 Hz 400 V	kW	5.5	6.9		
- at 60 Hz 460 V	kW	5.5	6.9		
Cooling air requirement	m^3/s	0.36	0.36		
Sound pressure level					
L_{pA} (1 m) at 50/60 Hz	dB(A)	71 / 73	71 / 73		
Line/load connection		Flat connector for screw			
		M12	M12		
Max. connection cross-sections					
- Line connection (U1, V1, W1)	mm^2	6 x 185	6 x 185		
- DC-link connection (DCP, DCN)	mm^2	6 x 185	6 x 185		
- PE connection	mm^2	4 x 240	4 x 240		
Max. cable length (total of all motor cables and DC link)					
- Shielded	m	4000	4800		
- Unshielded	m	6000	7200		
Degree of protection		IP00	IP00		

Article number	6SL3330-	1TE41-5AA3	1TE41-8AA3		
Dimensions					
- Width	mm	310	310		
- Height	mm	1653	1653		
- Depth	mm	550	550		
Frame size		GB	GD		
Weight	kg	214	214		
Recommended fuse ²⁾		3NE1437-2	3NE1435-2		
- Number per phase (connected in parallel)		2	3		
- Rated current		710	560		
- Frame size acc. to IEC 60269		3	3		
Minimum short-circuit current ³⁾	A	18400	18600		

- 1) The specified power loss is the maximum value at 100% capacity utilization. The value in normal operation is lower.
- 2) To achieve a UL-approved system, it is absolutely essential to use the fuse types specified in the table.
- 3) Minimum current required for reliable triggering of the protective devices.
- 4) The first value applies for one precharging resistor for each phase, the second value for two precharging resistors connected in parallel for each phase

Table 4- 15 Technical data for Basic Line Modules, 500 V ... 690 V 3 AC, Part 1

Article number	6SL3330-	1TG33-0AA3	1TG34-3AA3	1TG36-8AA3	1TG41-1AA3
Rated power					
- For I_{n_DC} (50 Hz, 690 V)	kW	250	355	560	900
- For I_{H_DC} (50 Hz, 690 V)	kW	195	280	440	710
- For I_{n_DC} (50 Hz, 500 V)	kW	175	250	390	635
- For I_{H_DC} (50 Hz, 500 V)	kW	165	235	365	595
- For I_{n_DC} (60 Hz, 575 V)	HP	250	350	600	900
- For I_{H_DC} (60 Hz, 575 V)	HP	200	300	450	800
DC-link current					
- Rated current I_{n_DC}	A	300	430	680	1100
- Base load current I_{H_DC}	A	234	335	530	858
- Maximum current I_{max_DC}	A	450	645	1020	1650
Input current					
- Rated current I_{n_E}	A	260	375	575	925
- Maximum current I_{max_E}	A	390	563	863	1388
- Maximum precharging current (max. 3 s)	A	internal	internal	internal	internal
Supply voltages					
- Line voltage	V_{ACrms}	3 AC 500 -10% (-15% < 1 min) ... 3 AC 690 +10%			
- Line frequency	Hz	47 ... 63 Hz			
- Electronic power supply	V_{DC}	24 (20.4 ... 28.8)			
- Fan supply voltage	V_{AC}	230 (195.5 ... 264.5)			
- DC-link voltage	V_{DC}	1.35 x U_{line} (partial load) / 1.32 x U_{line} (full load)			
Current consumption					
- Electronics current consumption (24 V DC)	A	1.1	1.1	1.1	1.1
- Fan power consumption (230 V AC)	A	1.1	1.1	1.1	4.5
Max. ambient temperature					
- Without derating	°C	40	40	40	40
- With derating	°C	55	55	55	55
DC-link capacitance					
- Basic Line Module	μF	3200	4800	7300	11600
- Drive line-up, max.	μF	25600	38400	58400	92800
Power loss, max. ¹⁾					
- at 50 Hz 690 V	kW	1.5	2.1	3.0	5.4
- at 60 Hz 575 V	kW	1.5	2.1	3.0	5.4
Cooling air requirement	m^3/s	0.17	0.17	0.17	0.36
Sound pressure level					
L_{pA} (1 m) at 50/60 Hz	dB(A)	66 / 68	66 / 68	66 / 68	71 / 73
Line/load connection		Flat connector for screw			
		M10	M10	M10	M12
Max. connection cross-sections					
- Line connection (U1, V1, W1)	mm^2	2 x 240	2 x 240	2 x 240	6 x 185
- DC-link connection (DCP, DCN)	mm^2	2 x 240	2 x 240	2 x 240	6 x 185
- PE connection	mm^2	2 x 240	2 x 240	2 x 240	4 x 240
Max. cable length (total of all motor cables and DC link)					
- Shielded	m	1500	1500	1500	2250
- Unshielded	m	2250	2250	2250	3375
Degree of protection		IP00	IP00	IP00	IP00

Article number	6SL3330-	1TG33-0AA3	1TG34-3AA3	1TG36-8AA3	1TG41-1AA3
Dimensions					
- Width	mm	310	310	310	310
- Height	mm	1164	1164	1164	1653
- Depth	mm	352	352	352	550
Frame size		FB	FB	FB	GB
Weight	kg	96	96	96	214
Recommended fuse ²⁾					
- Number per phase (connected in parallel)		3NE1230-2 1	3NE1333-2 1	3NE1436-2 1	3NE1334-2 2
- Rated current		315	450	630	500
- Frame size acc. to IEC 60269		2	2	3	3
Minimum short-circuit current ³⁾	A	3000	4400	8000	10400

1) The specified power loss is the maximum value at 100% capacity utilization. The value in normal operation is lower.

2) To achieve a UL-approved system, it is absolutely essential to use the fuse types specified in the table.

3) Minimum current required for reliable triggering of the protective devices.

Table 4- 16 Technical data for Basic Line Modules, 500 V ... 690 V 3 AC, Part 2

Article number	6SL3330-	1TG41-4AA3	1TG41-8AA3		
Rated power					
- For I_{n_DC} (50 Hz, 690 V)	kW	1100	1500		
- For I_{H_DC} (50 Hz, 690 V)	kW	910	1220		
- For I_{n_DC} (50 Hz, 500 V)	kW	810	1085		
- For I_{H_DC} (50 Hz, 500 V)	kW	755	1015		
- For I_{n_DC} (60 Hz, 575 V)	HP	1250	1500		
- For I_{H_DC} (60 Hz, 575 V)	HP	1000	1250		
DC-link current					
- Rated current I_{n_DC}	A	1400	1880		
- Base load current I_{H_DC}	A	1092	1467		
- Maximum current I_{max_DC}	A	2100	2820		
Input current					
- Rated current I_{n_E}	A	1180	1580		
- Maximum current I_{max_E}	A	1770	2370		
- Maximum precharging current (max. 3 s)	A	internal	234		
Supply voltages					
- Line voltage	V_{ACrms}	3 AC 500 -10% (-15% < 1 min) ... 3 AC 690 +10%			
- Line frequency	Hz	47 ... 63 Hz			
- Electronic power supply	V_{DC}	24 (20.4 ... 28.8)			
- Fan supply voltage	V_{AC}	230 (195.5 ... 264.5)			
- DC-link voltage	V_{DC}	$1.35 \times U_{line}$ (partial load) / $1.32 \times U_{line}$ (full load)			
Current consumption					
- Electronics current consumption (24 V DC)	A	1.1	1.1		
- Fan power consumption (230 V AC)	A	4.5	4.5		
Max. ambient temperature					
- Without derating	°C	40	40		
- With derating	°C	55	55		
DC-link capacitance					
- Basic Line Module	μF	15470	19500		
- Drive line-up, max.	μF	123760	78000/156000 ⁴⁾		
Power loss, max. ¹⁾					
- at 50 Hz 690 V	kW	5.8	7.3		
- at 60 Hz 575 V	kW	5.8	7.3		
Cooling air requirement	m^3/s	0.36	0.36		
Sound pressure level					
L_{pA} (1 m) at 50/60 Hz	dB(A)	71 / 73	71 / 73		
Line/load connection		Flat connector for screw			
		M12	M12		
Max. connection cross-sections					
- Line connection (U1, V1, W1)	mm^2	6 x 185	6 x 185		
- DC-link connection (DCP, DCN)	mm^2	6 x 185	6 x 185		
- PE connection	mm^2	4 x 240	4 x 240		
Max. cable length (total of all motor cables and DC link)					
- Shielded	m	2250	2750		
- Unshielded	m	3375	4125		

Article number	6SL3330-	1TG41-4AA3	1TG41-8AA3		
Degree of protection		IP00	IP00		
Dimensions					
- Width	mm	310	310		
- Height	mm	1653	1653		
- Depth	mm	550	550		
Frame size		GB	GD		
Weight	kg	214	214		
Recommended fuse ²⁾					
- Number per phase (connected in parallel)		3NE1436-2 2	3NE1435-2 3		
- Rated current		630	560		
- Frame size acc. to IEC 60269		3	3		
Minimum short-circuit current ³⁾	A	16000	18600		

- 1) The specified power loss is the maximum value at 100% capacity utilization. The value in normal operation is lower.
- 2) To achieve a UL-approved system, it is absolutely essential to use the fuse types specified in the table.
- 3) Minimum current required for reliable triggering of the protective devices.
- 4) The first value applies for one precharging resistor for each phase, the second value for two precharging resistors connected in parallel for each phase

Overload capability

The Basic Line Modules have an overload reserve.

The criterion for overload is that the Basic Line Module is operated with its base load current before and after the overload occurs (a load duration of 300 s is used as a basis here).

High overload

The base load current for a high overload I_{H_DC} is based on a duty cycle of 150% for 60 s; the max. current I_{max_DC} can flow for 5 s.

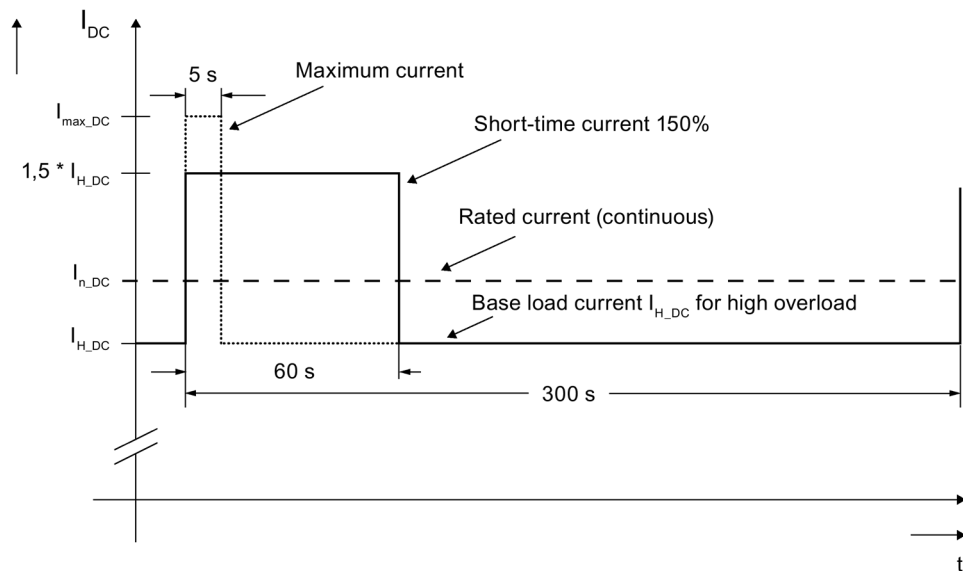

Figure 4-12 High overload

4.3 Smart Line Modules

4.3.1 Description

Smart Line Modules are infeed/regenerative feedback units. Like the Basic Line Module, they supply energy to the connected Motor Modules, but unlike the Basic Line Module, they can feed back regenerative energy.

The infeed occurs over a diode jumper, while stable, line-commutated regenerative feedback takes place via IGBTs with 100% continuous energy regeneration.

The DC-link voltage is greater than the rms value of the line rated voltage by a factor of 1.32 (under partial load) or 1.30 (under full load).

Table 4- 17 Overview of Smart Line Modules

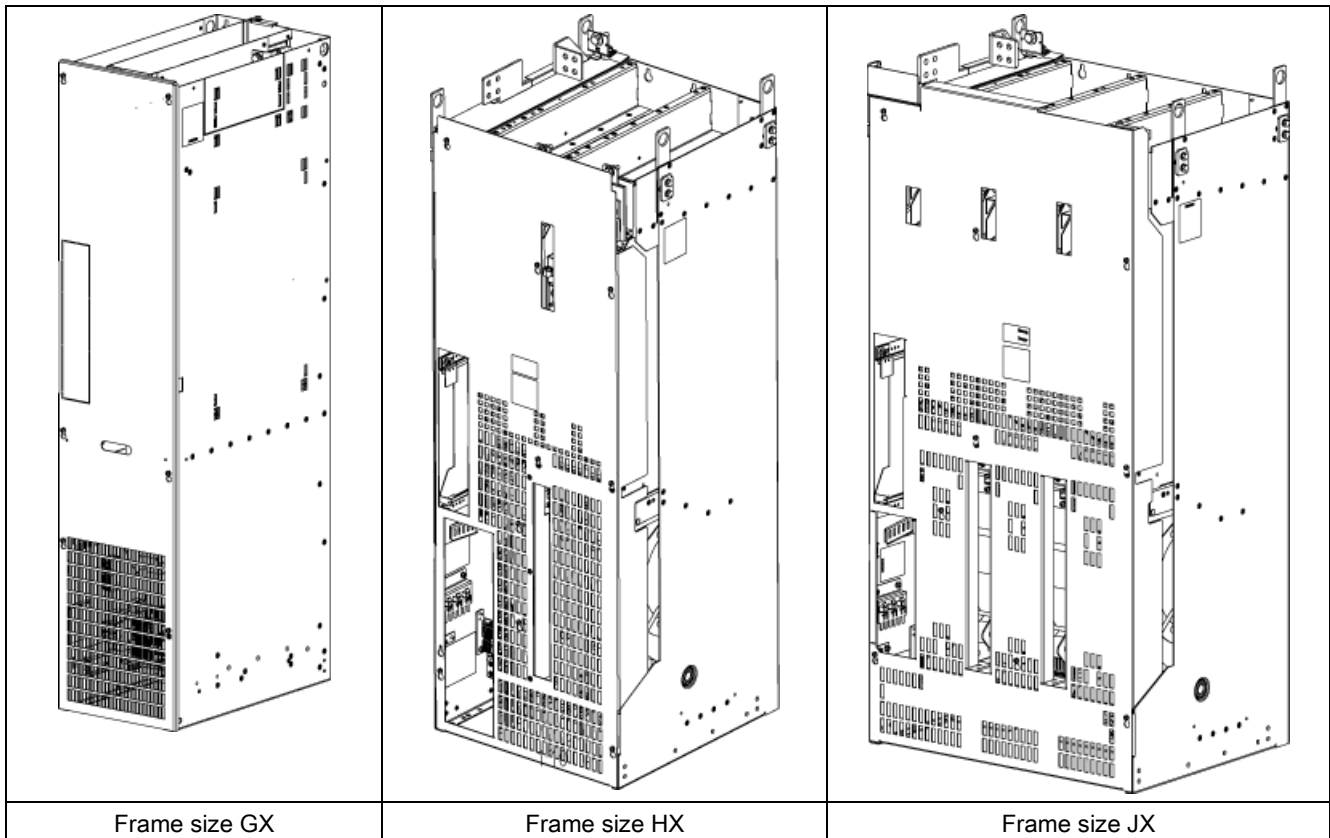

Components of the Smart Infeed

A Smart Infeed comprises a Smart Line Module and an external line connection, which comprises bypass contactor, precharging input circuit, fuse, and line reactor.

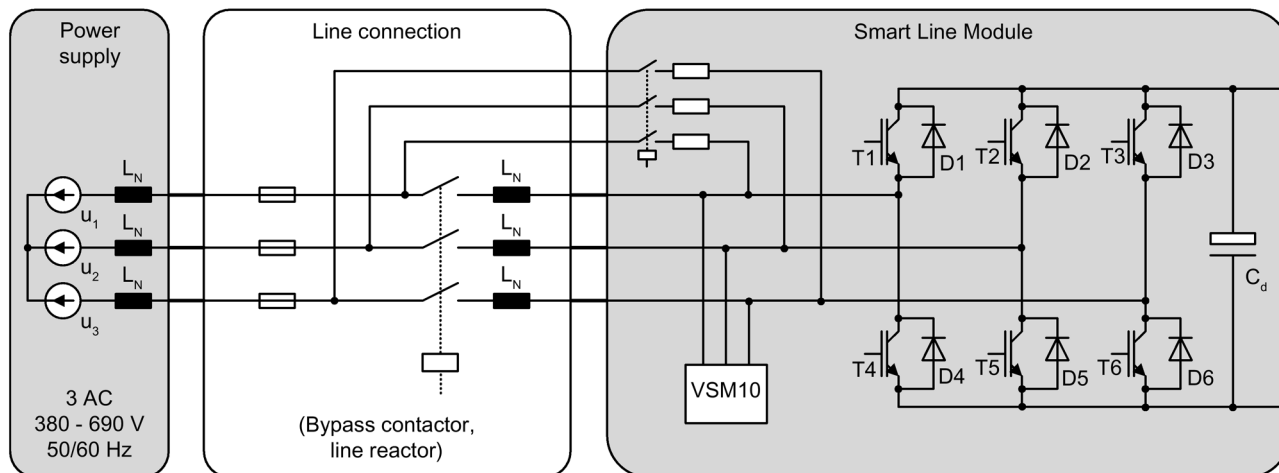

Figure 4-13 Overview of Smart Infeed

Operating principle

One or more Motor Modules can be connected to the power supply network via the Smart Line Module. The Smart Line Module provides the DC-link voltage for the Motor Modules. The regenerative feedback capability of the Smart Line Module can be deactivated by parameterization.

The Smart Line Module is suitable for direct operation both on TN and on IT and TT systems.

In generator mode, the Smart Line Module feeds regenerative energy into the supply network. An integrated Voltage Sensing Module 10 (VSM10) is used for sensing the line voltage for regenerative feedback

The Smart Line Module is used for:

- Machines with medium dynamic requirements
- Infrequent braking cycles and high braking energy

Parallel connection of Smart Line Modules to increase power rating

Up to four Smart Line Modules with the same power rating can be connected in parallel in order to increase power.

The following rules must be observed when connecting Smart Line Modules in parallel:

- Up to four identical Smart Line Modules can be connected in parallel.
- A common Control Unit is required whenever the modules are connected in parallel.
- With multiple infeeds, power must be supplied to the systems from a common infeed point (i.e. different supply systems are not permitted).
- A line reactor must be series-connected to every parallel-connected Smart Line Module.
- A derating factor of 7.5% must be taken into consideration, regardless of the number of modules connected in parallel.

Note

Mixed operation is not possible

It is only possible to connect identical power units in parallel if all power units have the same hardware version. Mixed operation between a power unit with Control Interface Module (article number 6SL33xx-xxxx-xAA3) and a power unit with Control Interface Board (article number 6SL33xx-xxxx-xAA0) is not possible.

NOTICE

Converter error due to missing circuit breaker wiring
--

If the leading contact of the circuit breaker is not wired to the OFF2 signal from the Control Unit, the SINAMICS control reacts with the "Overvoltage" or "Undervoltage" error if the circuit breaker is triggered.
--

- | |
|---|
| <ul style="list-style-type: none">• Connect the signal from the leading contact of the circuit breaker to the OFF2 signal from the Control Unit. In this way, the SINAMICS control is able to delete pulses from the Smart Line Modules in good time, before the circuit breaker is opened. |
|---|

4.3.2 Safety information

 **WARNING****Not observing fundamental safety instructions and residual risks**

Not observing fundamental safety instructions and residual risks listed in Chapter 1 can result in accidents with severe injuries or death.

- Comply with the fundamental safety instructions.
- When assessing the risk, take into account remaining risks.

 **DANGER****Electric shock due to a high DC link voltage**

As long as the Line Module is connected to the line supply, the DC link is charged with a high voltage. Contact with components can result in death or serious injury.

- Isolate the Line Module from the line supply during installation of maintenance work, e.g. via the line contactor or main switch.

 **WARNING****Electric shock or fire due to overcurrent protective equipment that trips too late**

Overcurrent protective devices that do not trip or trip too late can cause an electric shock or fire.

- To protect personnel and for fire protection purposes, at the infeed point, the short-circuit rating and loop impedance must correspond to the specifications in the documentation in order for the installed overcurrent protection devices to trip within the specified time.

 **WARNING****High leakage currents when the protective conductor in the line feeder cable is interrupted**

The drive components conduct a high leakage current via the protective conductor. Touching conductive parts when the protective conductor is interrupted can result in death or serious injury.

- Ensure that the external protective conductor satisfies at least one of the following conditions:
 - It has been installed so that it is protected against mechanical damage. ¹⁾
 - For an individual core, it has a cross-section of at least 10 mm² Cu.
 - If it is a conductor of a multi-conductor cable, it has a cross-section of at least 2.5 mm² Cu.
 - It has a second protective conductor in parallel with the same cross-section.
 - It complies with the local regulations for equipment with increased leakage current.
- ¹⁾ Cables laid within control cabinets or closed machine housings are considered to be adequately protected from mechanical damage.

 WARNING
Fire due to inadequate ventilation clearances Inadequate ventilation clearances can cause overheating with a risk for personnel through smoke development and fire. This can also result in more downtimes and reduced service lives of Line Modules. <ul style="list-style-type: none">• Observe the ventilation clearances above, below, and in front of the Line Modules, which are specified in the dimension drawings.

 CAUTION
Fire due to overheating when the total length of the power cables is exceeded Overheating and a fire can result when the total length of the power cables is exceeded. <ul style="list-style-type: none">• Ensure that the total length of the power cables (motor feeder cables and DC link cables) does not exceed the values specified in the technical data.

NOTICE
Material damage caused by the failure to remove linkage levers for devices of frame sizes HX and JX The failure to remove linkage levers from devices of frame sizes HX and JX can cause damage to the device as a result of undershooting the necessary voltage clearances. <ul style="list-style-type: none">• For devices of frame sizes HX and JX, remove the linkage levers marked in red once the devices have been installed.

NOTICE
Material damage caused by loose power connections Insufficient tightening torques or vibration can result in faulty electrical connections. This can cause fire damage or malfunctions. <ul style="list-style-type: none">• Tighten all power connections with the specified tightening torques, e.g. line supply connection, motor connection, DC link connections.• Check the tightening torques of all power connections at regular intervals and tighten them when required. This applies in particular after transport.

NOTICE
Damage to the devices when performing a voltage test as a result of connections that are not disconnected As part of routine tests, SINAMICS S components undergo a voltage test according to EN 61800-5-1. Connected devices can be damaged. <ul style="list-style-type: none">• Disconnect or unplug all SINAMICS devices before the voltage test of the machine equipment according to EN 60204-1, Section 18.4.

NOTICE**Damage through use of incorrect DRIVE-CLiQ cables**

Damage or malfunctions can occur on the devices or system when DRIVE-CLiQ cables are used that are either incorrect or have not been released for this purpose.

- Only use suitable DRIVE-CLiQ cables that have been released by Siemens for the particular application.

Note**Operation on line supplies where energy recovery is not possible**

In line supply systems without energy recovery capability (e.g. a diesel generator), device faults can occur as the braking energy cannot be dissipated.

- For line supplies without regenerative feedback capability (e.g. diesel generator), deactivate the regenerative feedback capability of the Line Modules using the appropriate parameter (see SINAMICS S120/S150 List Manual).
 - The braking energy must then be dissipated via an additional Braking Module with braking resistor in the drive line-up.
-

4.3.3 Interface description

4.3.3.1 Overview

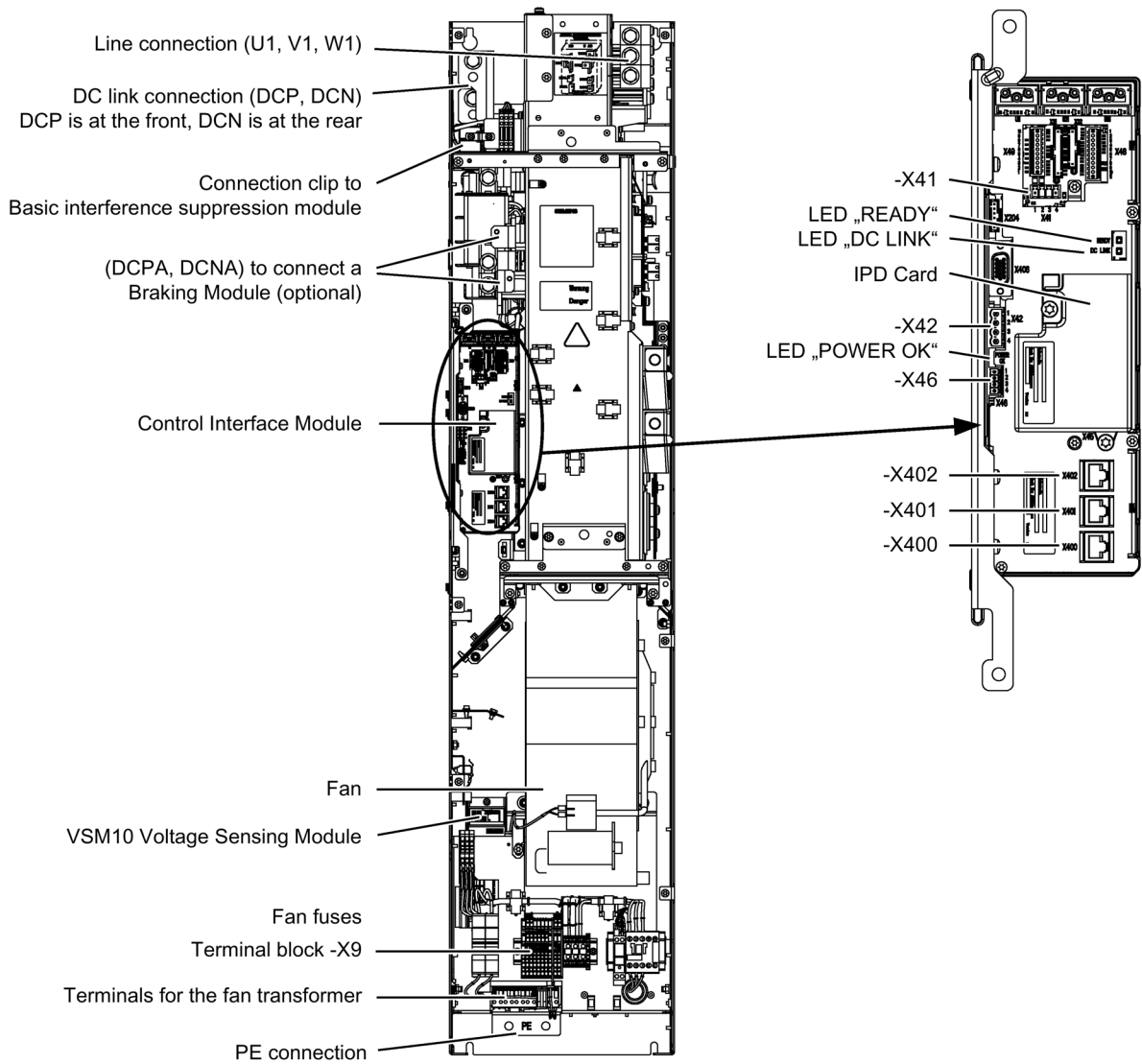

Figure 4-14 Smart Line Module, frame size GX

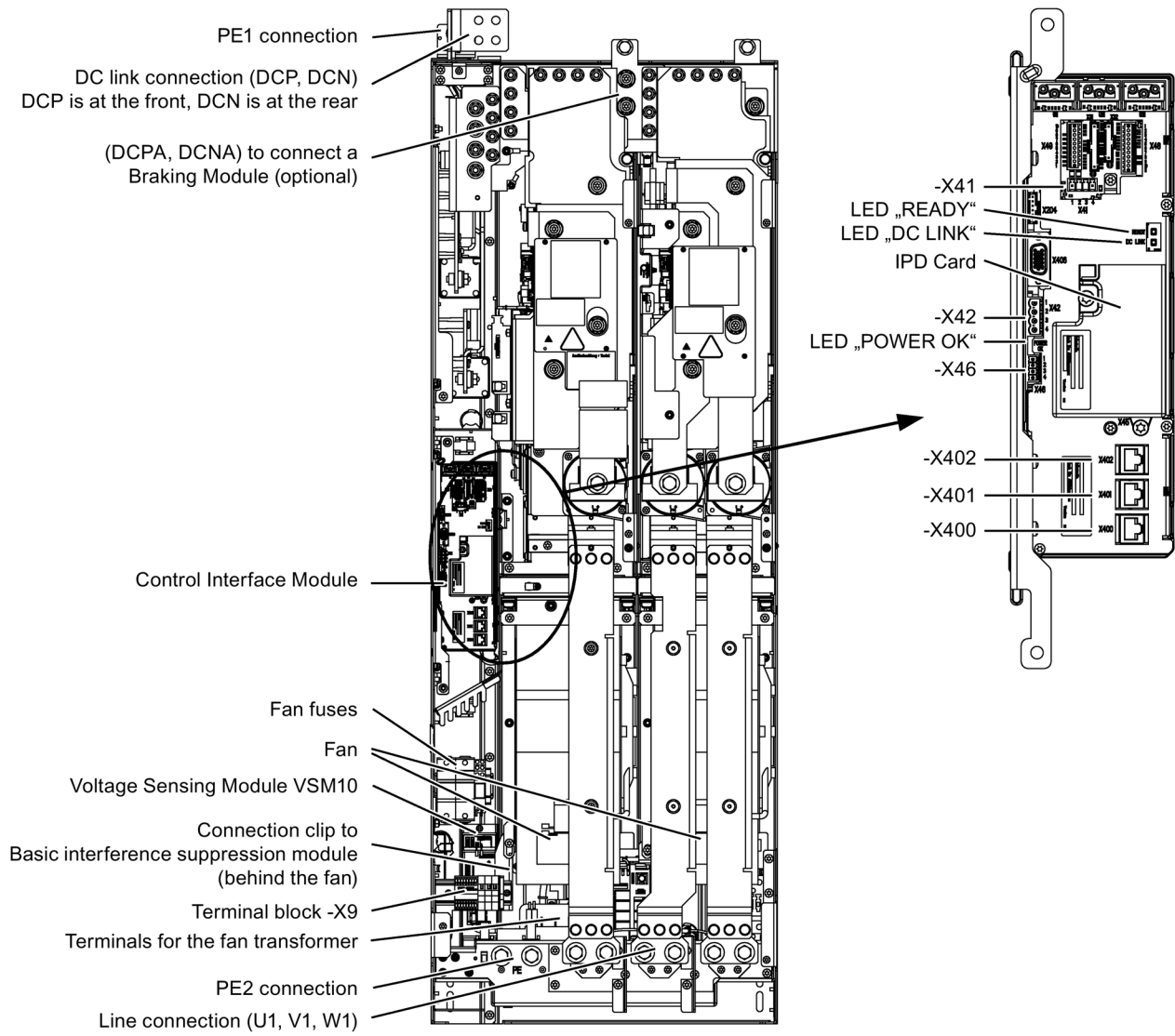

Figure 4-15 Smart Line Module, frame size HX

4.3 Smart Line Modules

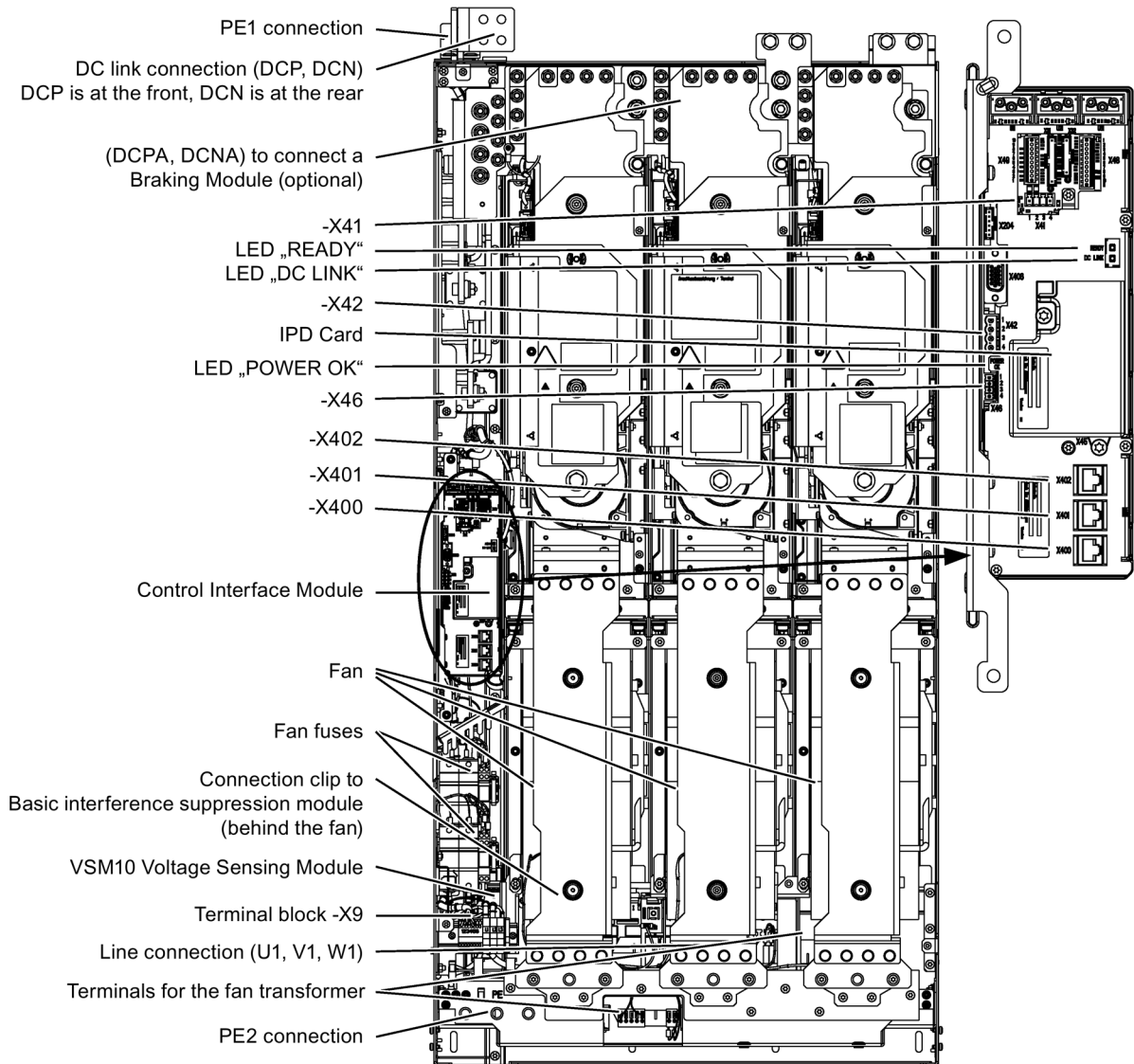

Figure 4-16 Smart Line Module, frame size JX

4.3.3.2 Connection example

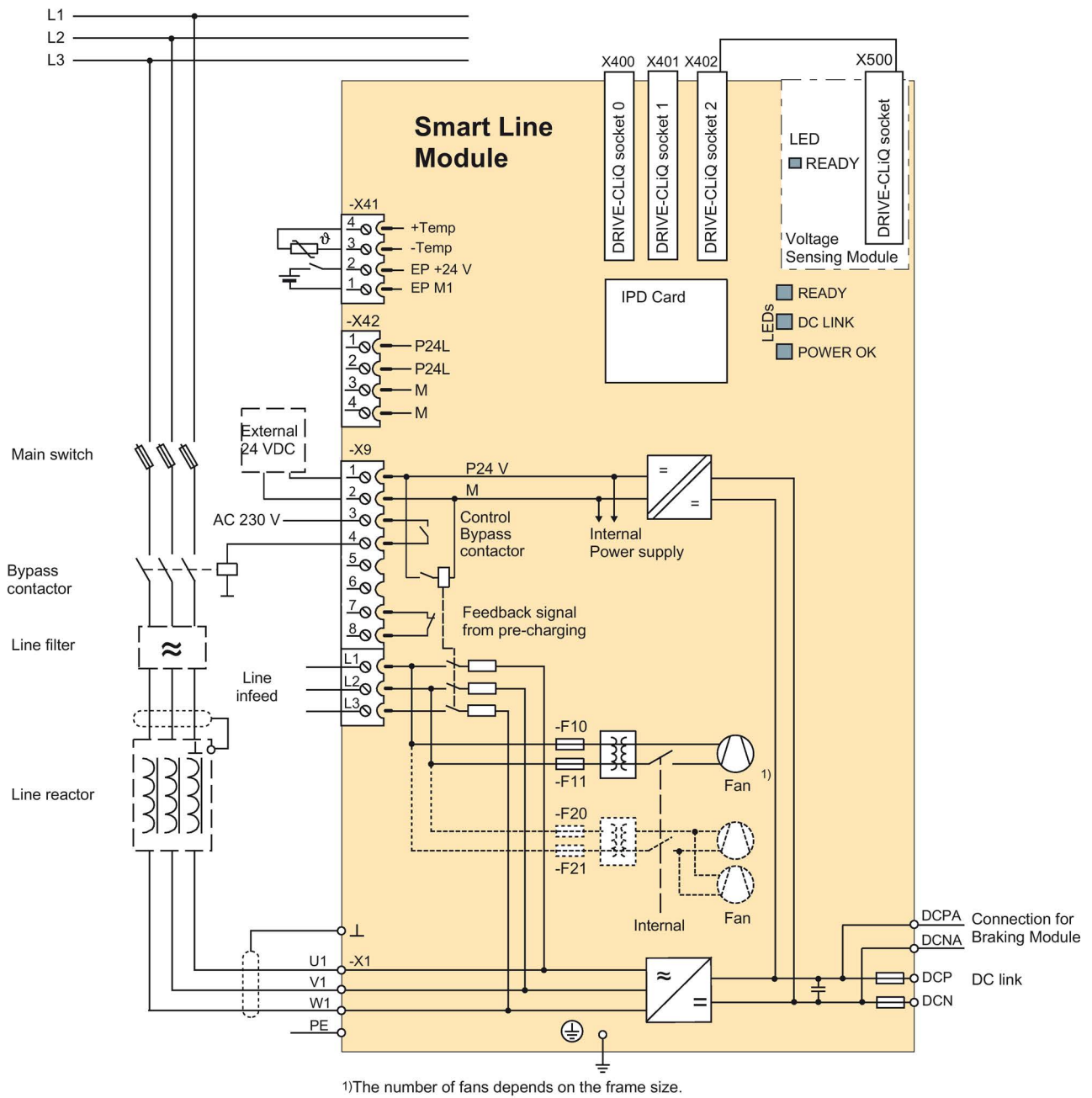

Figure 4-17 Smart Line Module wiring diagram

NOTICE**Damage to the device due to different phase sequence in the precharging and main circuits**

If the precharging and main circuits have different phase sequences, the precharging resistors could be overloaded and destroyed during the brief overlap period where both contactors are simultaneously closed.

- Wire the precharging and main circuits with the same phase sequence.

4.3.3.3 Line/load connection

Table 4- 18 Line/load connection of the Smart Line Module

Terminals	Technical specifications
U1, V1, W1 3 AC power input	Voltage: <ul style="list-style-type: none"> • 3 AC 380 V -10% (-15% < 1 min) ... 3 AC 480 V +10% • 3 AC 500 V -10% (-15% < 1 min) ... 3 AC 690 V +10% Frequency: 47 ... 63 Hz Connecting thread: <ul style="list-style-type: none"> • Frame size GX: M10 / 25 Nm for cable lugs in accordance with DIN 46234 / DIN 46235 ¹⁾ • Frame sizes HX / JX: M12 / 50 Nm for cable lugs in accordance with DIN 46234 / DIN 46235 ¹⁾
DCPA, DCNA Connection for Braking Module	Voltage: <ul style="list-style-type: none"> • 500 ... 630 V DC • 650 ... 900 V DC Connections: <ul style="list-style-type: none"> • Frame size GX: Threaded bolts M6 / 6 Nm for cable lugs in accordance with DIN 46234 / DIN 46235 ¹⁾ • Frame sizes HX / JX: Connection for connection clip
DCP, DCN DC power output	Voltage: <ul style="list-style-type: none"> • 500 ... 630 V DC • 650 ... 900 V DC Connections: <ul style="list-style-type: none"> • Frame size GX: Thread M10 / 25 Nm for cable lugs in accordance with DIN 46234 / DIN 46235 ¹⁾ • Frame sizes HX / JX: d = 12 mm (M12/50 Nm) flat connector for busbar
PE connection PE1, PE2	Connecting thread: <ul style="list-style-type: none"> • Frame size GX: M10 / 25 Nm for cable lugs in accordance with DIN 46234 / DIN 46235 ¹⁾ • Frame sizes HX / JX: M12 / 50 Nm for cable lugs in accordance with DIN 46234 / DIN 46235 ¹⁾

¹⁾ Dimensions for connecting alternative cable lugs, see "cable lugs" in the appendix.

4.3.3.4 X9 terminal strip

Table 4- 19 Terminal strip X9

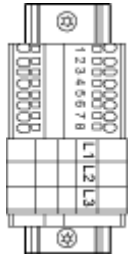
	Terminal	Signal name	Technical specifications
	1	P24V	External 24 V DC supply Voltage: 24 V DC (20.4 ... 28.8 V) Current consumption: max. 1.7 A
	2	M	
	3	Bypass contactor control	240 V AC: 8 A max. 24 V DC: max. 1 A isolated
	4		
	5	Not assigned	
	6		
	7	Checkback signal pre-charge contactor	Voltage: 230 V AC Maximum permissible current: 6 A isolated <ul style="list-style-type: none"> • Contact closed: Contactor is de-energized • Contact open: Contactor is energized
	8		
	L1	Connection of precharging circuit and fan supply	3 AC 380 ... 3 AC 480 V or 3 AC 500 ... 3 AC 690 V Current consumption: See Technical data
	L2		
L3			
Max. connectable cross-section: - terminal 1 ... 8: 2.5 mm ² - terminals L1 ... L3: 16 mm ²			

4.3.3.5 X41 EP terminal / temperature sensor connection

Table 4- 20 Terminal strip X41

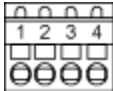
	Terminal	Function	Technical specifications
	1	EP M1 (Enable Pulses)	Supply voltage: 24 V DC (20.4 ... 28.8 V) Current consumption: 10 mA
	2	EP +24 V (Enable Pulses)	
	3	- Temp	Temperature sensor connection KTY84-1C130 / PT1000 / PTC
	4	+ Temp	
Max. connectable cross-section: 1.5 mm ²			



! WARNING
Electric shock in the event of voltage flashovers at the temperature sensor
Voltage flashovers in the signal electronics can occur in motors without safe electrical separation of the temperature sensors.
<ul style="list-style-type: none">• Only use temperature sensors that fully comply with the specifications of the safety isolation.• If safe electrical separation cannot be guaranteed (for linear motors or third-party motors, for example), use a Sensor Module External (SME120 or SME125) or Terminal Module TM120.

NOTICE
Device failure as a result of unshielded or incorrectly routed cables to temperature sensors
Unshielded or incorrectly routed cables to temperature sensors can result in interference being coupled into the signal processing electronics from the power side. This can result in significant disturbance of all signals (fault messages) up to failure of individual components (destruction of the devices).
<ul style="list-style-type: none">• Only use shielded cables as temperature sensor cables.• If temperature sensor cables are routed together with the motor cable, use separately shielded cables twisted in pairs.• Connect the cable shield to ground potential through a large surface area.• Recommendation: Use the appropriate MOTION-CONNECT cables.

NOTICE
Damage to motor in the event of incorrectly connected KTY temperature sensor
If a KTY temperature sensor is connected with incorrect polarity, it is not possible to detect when the motor overheats. Overheating can cause damage to the motor.
<ul style="list-style-type: none">• Connect a KTY temperature sensor with the correct polarity.

Note

The temperature sensor connection can be used for motors that are equipped with a KTY84-1C130, PT1000 or PTC measuring sensor in the stator windings.

Note

Connection to terminals 1 and 2

For operation, 24 V DC must be connected to terminal 2 and ground to terminal 1. Pulse suppression is activated when removed.

4.3.3.6 X42 terminal strip

Table 4- 21 Terminal strip X42 voltage supply for Control Unit, Sensor Module and Terminal Module

	Terminal	Function	Technical specifications
	1	P24L	Voltage supply for Control Unit, Sensor Module and Terminal Module (18 to 28.8 V) Maximum load current: 3 A
	2		
	3	M	
	4		
Max. connectable cross-section: 2.5 mm ²			

Note

Connection options for terminal strip X42

The terminal strip is not intended for free 24 V DC availability (for example for supplying further line-side components), as the voltage supply of the Control Interface Module could also be overloaded and operating capability could thus be compromised.

4.3.3.7 DRIVE-CLiQ interfaces X400, X401, X402

Table 4- 22 DRIVE-CLiQ interfaces X400, X401, X402

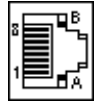
	PIN	Signal name	Technical specifications
	1	TXP	Transmit data +
	2	TXN	Transmit data -
	3	RXP	Receive data +
	4	Reserved, do not use	
	5	Reserved, do not use	
	6	RXN	Receive data -
	7	Reserved, do not use	
	8	Reserved, do not use	
	A	+ (24 V)	24 V power supply
	B	M (0 V)	Electronics ground
Blanking plate for DRIVE-CLiQ interfaces (50 pcs.) Article number: 6SL3066-4CA00-0AA0			

4.3.3.8 Meaning of the LEDs on the Control Interface Module in the Smart Line Module

Table 4- 23 Meaning of the LEDs "READY" and "DC LINK" on the Control Interface Module in the Smart Line Module

LED state		Description
READY	DC LINK	
Off	Off	The electronics power supply is missing or out of tolerance.
Green	--- ¹⁾	The component is ready for operation and cyclic DRIVE-CLiQ communication is taking place.
	Orange	The component is ready for operation and cyclic DRIVE-CLiQ communication is taking place. The DC-link voltage is present.
	Red	The component is ready for operation and cyclic DRIVE-CLiQ communication is taking place. The DC link voltage lies outside the permitted tolerance range.
Orange	Orange	DRIVE-CLiQ communication is being established.
Red	--- ¹⁾	This component has at least one fault. Remark: The LED is activated irrespective of whether the corresponding messages have been reconfigured.
Flashing light 0.5 Hz: green/red	--- ¹⁾	Firmware is being downloaded.
Flashing light 2 Hz: green/red	--- ¹⁾	Firmware download is complete. Waiting for POWER ON.
Flashing light 2 Hz: green/orange or red/orange	--- ¹⁾	Detection of the components via LED is activated (p0124). Note: Both options depend on the LED status when module recognition is activated via p0124 = 1.

¹⁾ Irrespective of the status of the LED "DC LINK"

Table 4- 24 Meaning of the LED "POWER OK" on the Control Interface Module in the Smart Line Module

LED	Color	Status	Description
POWER OK	Green	Off	DC link voltage or control voltage at -X9 too low.
		On	The component is ready for operation.
		Flashing light	There is a fault. If the LED continues to flash after you have performed a POWER ON, please contact your Siemens service center.



<p>⚠ WARNING</p> <p>Electric shock when live parts of the DC link are touched</p> <p>Hazardous DC link voltages may be present at any time regardless of the status of the "DC LINK" LED. This means that when live parts are touched, this can result in death or serious injury.</p> <ul style="list-style-type: none"> Observe the warning information on the component.
--

4.3.4 Dimension drawing

Dimension drawing, frame size GX

The mandatory cooling clearances are indicated by the dotted line.

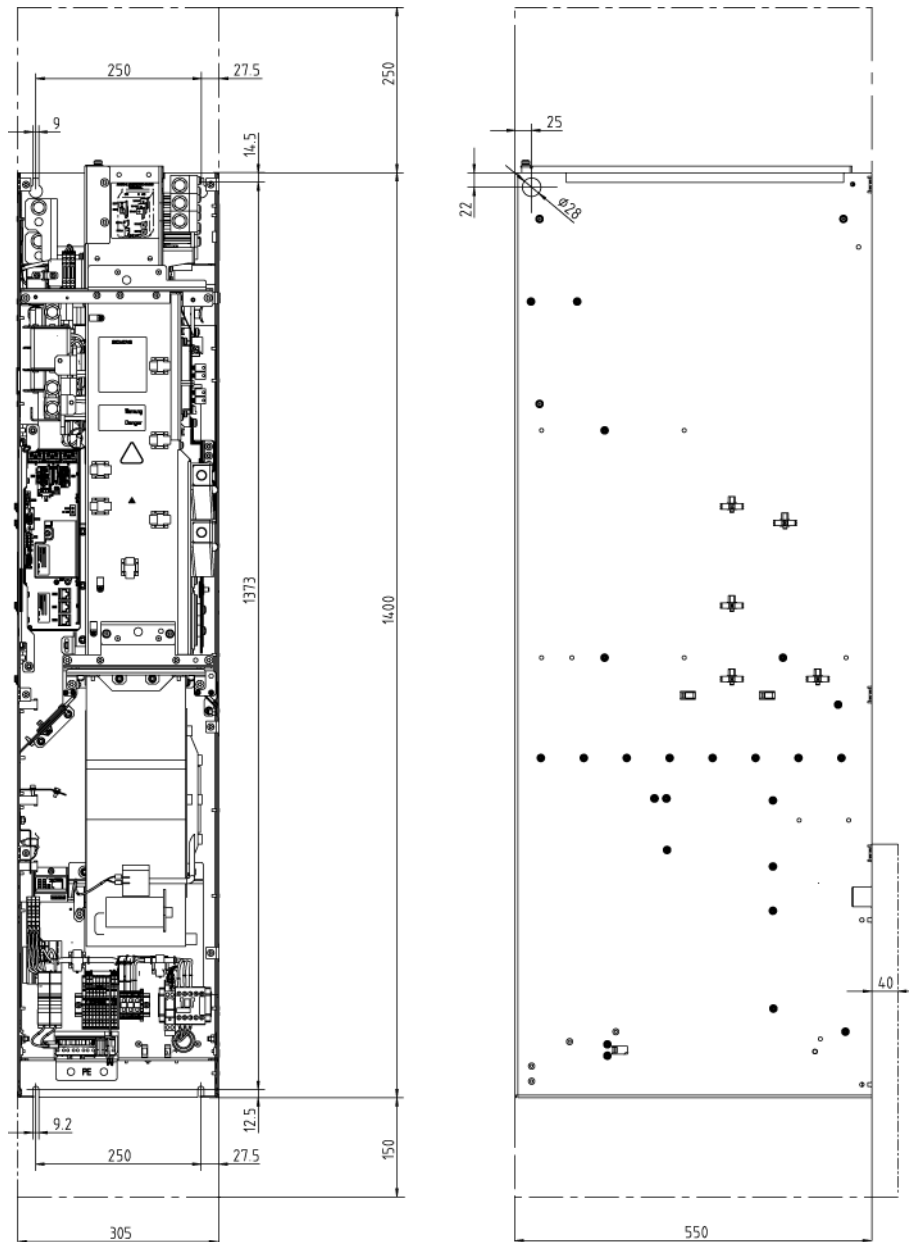

Figure 4-18 Dimension drawing Smart Line Module, frame size GX. Front view, side view

Dimension drawing, frame size HX

The mandatory cooling clearances are indicated by the dotted line.

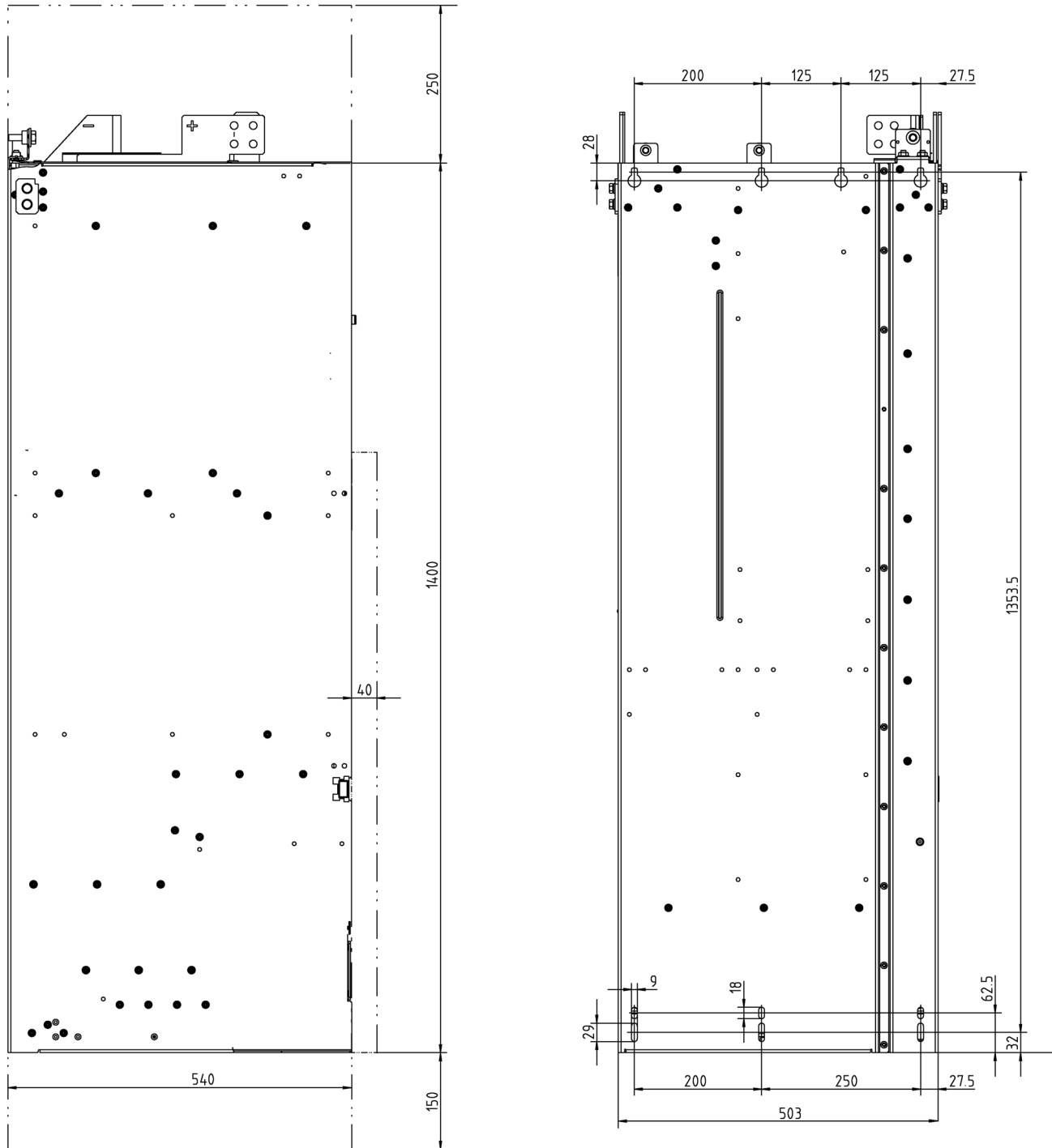

Figure 4-19 Dimension drawing Smart Line Module, frame size HX. Side view, rear view

Dimension drawing, frame size JX

The mandatory cooling clearances are indicated by the dotted line.

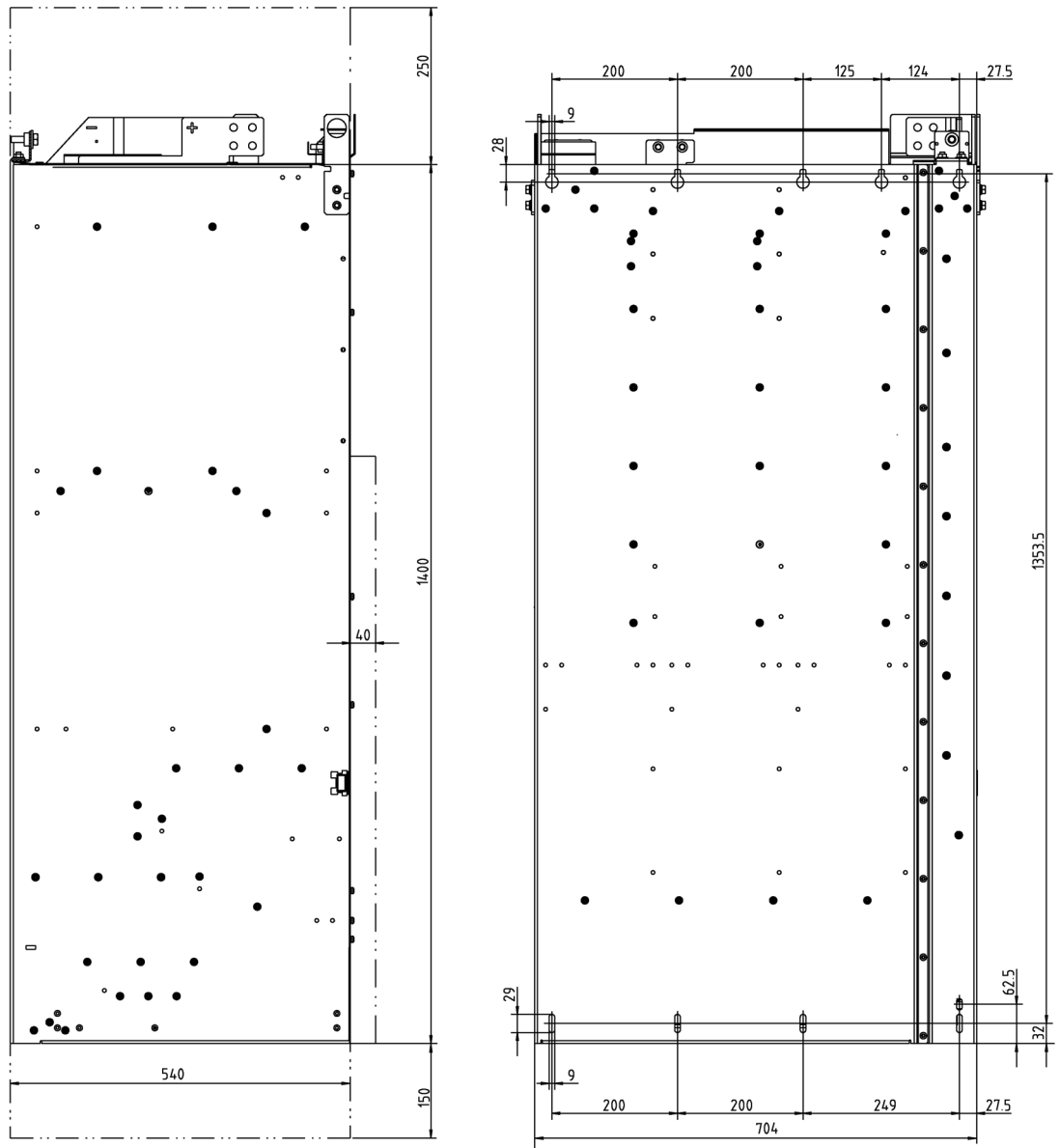

Figure 4-20 Dimension drawing Smart Line Module, frame size JX. Side view, rear view

4.3.5 Electrical connection

Operating a Smart Line Module on a non-grounded line supply (IT system)

When the device is operated on an ungrounded line supply (IT system), the integrated basic interference suppression modules must be deactivated by screwing out a connection clip.

Note

Warning label on the connection clip

A yellow warning label is attached to each connection clip so that it is easier to find.

- The warning label must be removed from the connection clip (by pulling it off) if the connection clip is to remain in the unit (operation on a grounded line supply).
- The warning label must be removed together with the connection clip if the unit is operated on a non-grounded line supply (IT system).



Figure 4-21 Warning label on the connection clip

With frame sizes HX and JX, you must remove the left-hand fan before removing the connection clip (see "Replacing components").

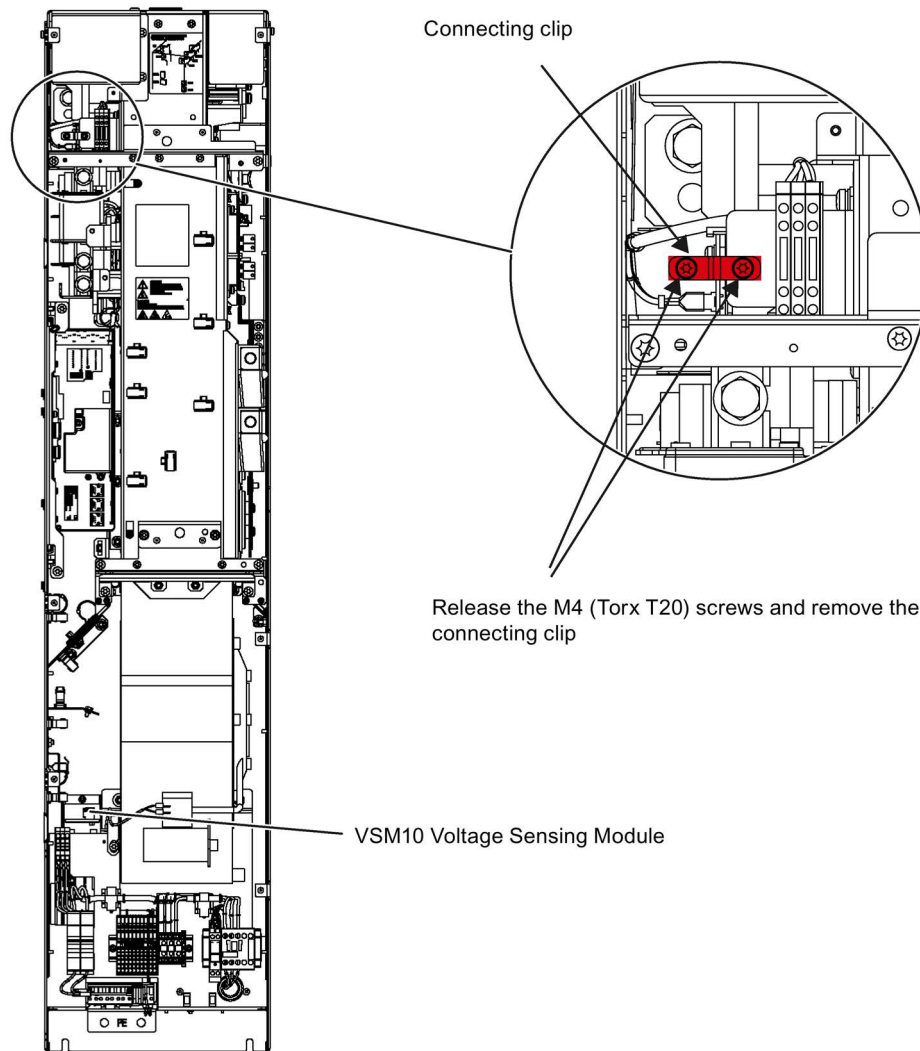

Figure 4-22 Removing the connection clip to the basic interference suppression module in the Smart Line Module for frame size GX

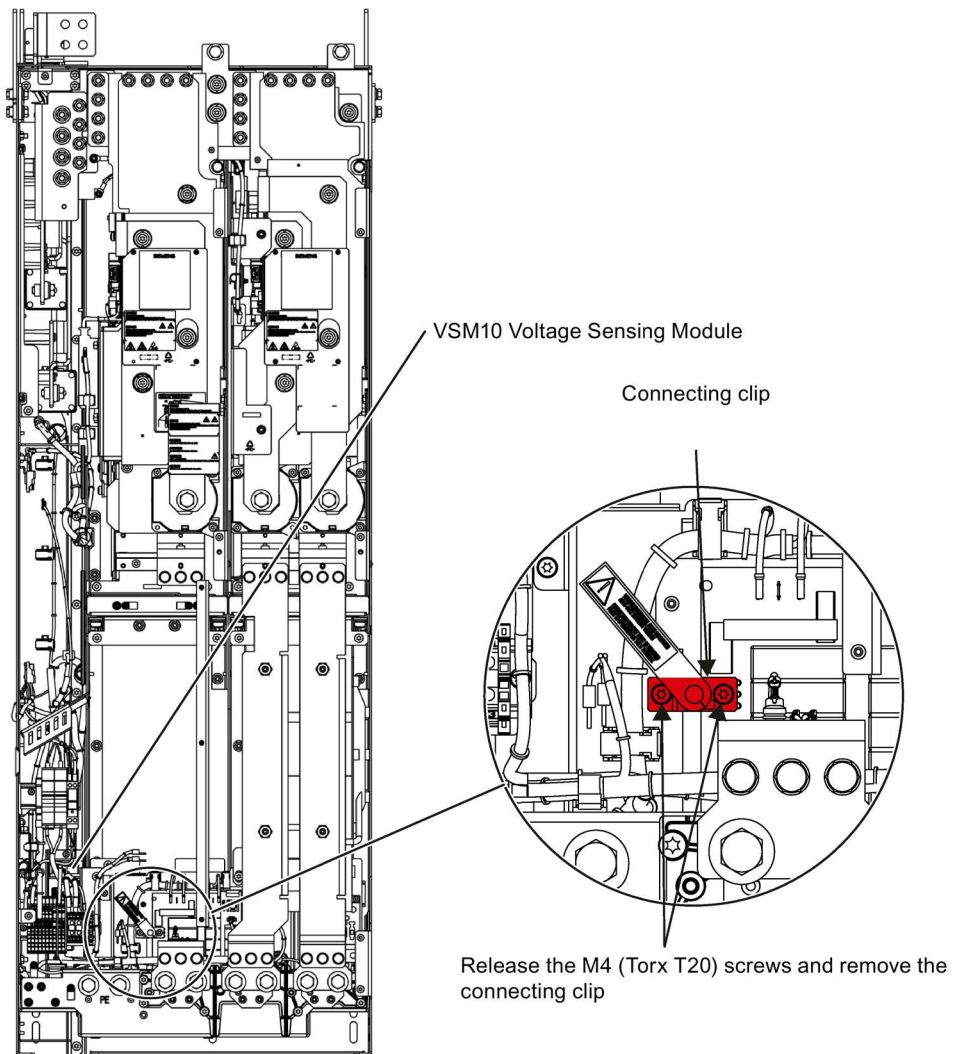

Figure 4-23 Removing the connection clip to the basic interference suppression module in the Smart Line Module for frame size HX

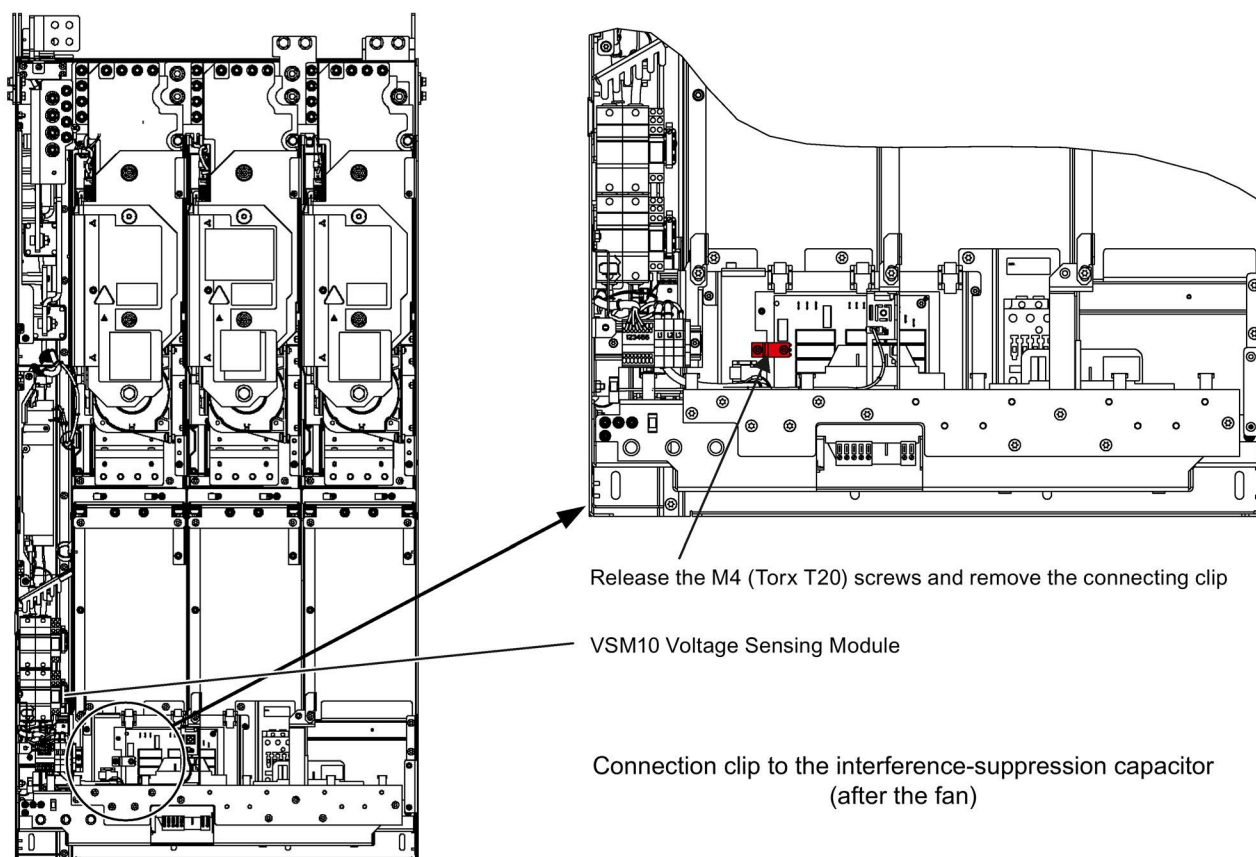

Figure 4-24 Removing the connection clip to the basic interference suppression module in the Smart Line Module for frame size JX

NOTICE

Damage to the device through not removing the connection clip with a non-grounded line supply

Failure to remove the connection clip to the basic interference suppression module on a non-grounded line supply (IT system) can cause significant damage to the device.

- With a non-grounded line supply (IT system), remove the connection clip to the basic interference suppression module.

Removing the connector jumper on the VSM10 Voltage Sensing Module

When operating the Smart Line Module on an ungrounded line supply (IT system), at the Voltage Sensing Module (VSM10), remove the connector jumper in terminal X530 at the lower side of the component.

Use two screwdrivers or another suitable tool to relieve the holding springs in the terminal and then withdraw the connector jumper.

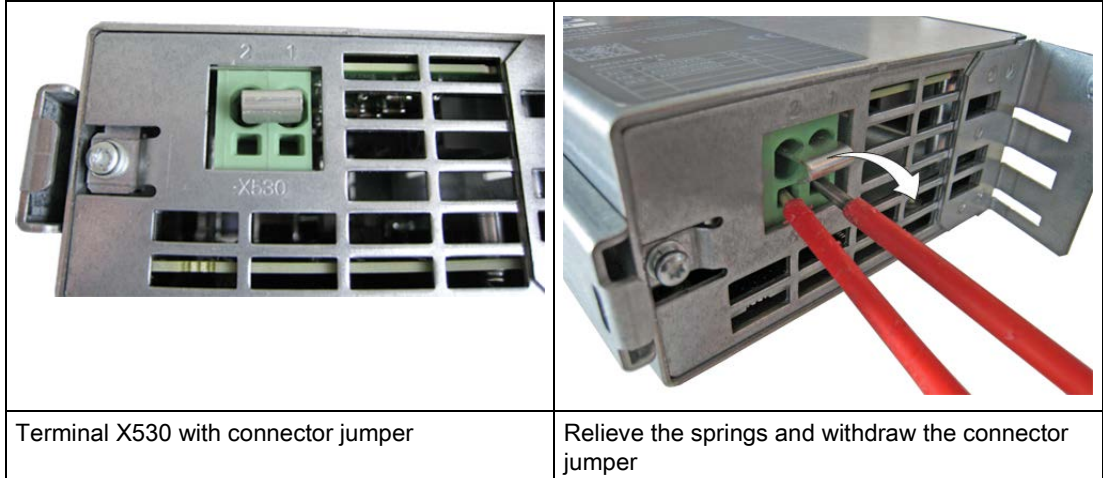

Adjusting the fan voltage (-T10)

The power supply for the device fans (1 AC 230 V) in the Smart Line Module (-T10) is taken from the line supply using transformers. The installation position of the transformers is indicated in the interface descriptions.

The transformers are fitted with primary taps so that they can be fine-tuned to the line supply voltage.

If necessary, the connection fitted in the factory, shown with a dashed line, must be reconnected to the actual line voltage.

Note

Two transformers (-T10 and -T20) are installed in Smart Line Modules, frame size JX. The two primary-side terminals on each of these devices must be adjusted together.

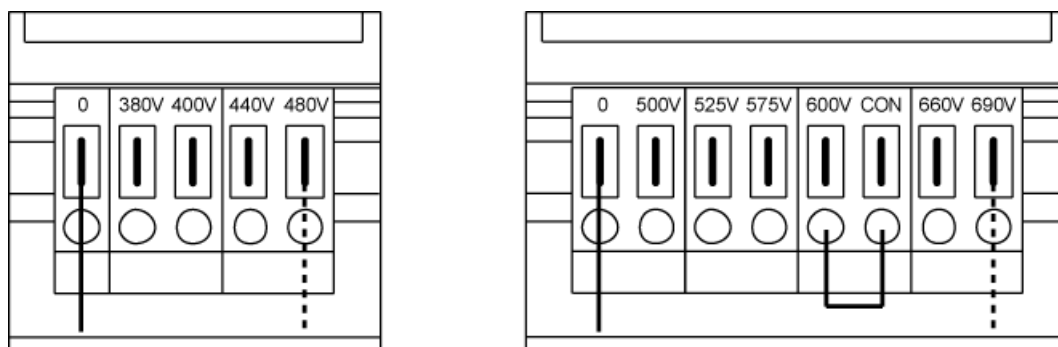

Figure 4-25 Setting terminals for the fan transformers (3 AC 380 to 480 V / 3 AC 500 to 690 V)

The supply voltage assignments for making the appropriate setting on the fan transformer are indicated in the following tables (factory presetting: 480 V / 0 V or 690 V / 0 V).

Note

With the 3 AC 500 V to 690 V fan transformer, a jumper is inserted between the "600 V" terminal and "CON" terminal. The jumper between terminal "600 V" and "CON" is for internal use.

 WARNING
Fire due to overheating resulting from insufficient equipment fan voltage
If the terminals are not reconnected to the actual line voltage, overheating and human danger due to smoke and fire may result. This can also cause the fan fuses to blow due to overload.
<ul style="list-style-type: none"> Set the terminals in accordance with the actual line voltage.

Table 4- 25 Line voltage assignment for the setting at the fan transformer (3 AC 380 ... 480 V)

Line voltage	Tap at the fan transformer (-T10)
380 V \pm 10%	380 V
400 V \pm 10%	400 V
440 V \pm 10%	440 V
480 V \pm 10%	480 V

Table 4- 26 Line voltage assignment for the setting at the fan transformer (3 AC 500 ... 690 V)

Line voltage	Tap at the fan transformer (-T10)
500 V \pm 10%	500 V
525 V \pm 10%	525 V
575 V \pm 10%	575 V
600 V \pm 10%	600 V
660 V \pm 10%	660 V
690 V \pm 10%	690 V

4.3.6 Technical data

Table 4- 27 Technical data for Smart Line Modules, 3 AC 380 V ... 480 V, Part 1

Article number	6SL3330-	6TE35-5AA3	6TE37-3AA3	6TE41-1AA3	6TE41-3AA3
Rated output					
- For I_{n_DC} (50 Hz, 400 V)	kW	250	355	500	630
- For I_{H_DC} (50 Hz, 400 V)	kW	235	315	450	555
- For I_{n_DC} (60 Hz, 460 V)	HP	385	545	770	970
- For I_{H_DC} (60 Hz, 460 V)	HP	360	485	695	855
DC-link current					
- Rated current I_{n_DC}	A	550	730	1050	1300
- Base load current I_{H_DC}	A	490	650	934	1157
- Maximum current I_{max_DC}	A	825	1095	1575	1950
Infeed/regenerative feedback current					
- Rated current I_{n_E}	A	463	614	883	1093
- Maximum current I_{max_E}	A	694	921	1324	1639
Supply voltages		3 AC 380 -10% (-15% < 1 min) ... 3 AC 480 +10%			
- Line voltage	V_{ACrms}				
- Line frequency	Hz				
- Electronic power supply	V_{DC}				
- DC-link voltage	V_{DC}	24 (20.4 ... 28.8) 1.32 x U_{line} (partial load) / 1.30 x U_{line} (full load)			
Current consumption					
- Electronics current consumption (24 V DC)	A	1.35	1.35	1.4	1.5
- Fan power consumption (at 400 V AC)	A	1.8	1.8	3.6	5.4
Max. precharging current (max. 3 s)	A	33	33	98	98
Max. ambient temperature					
- Without derating	°C	40	40	40	40
- With derating	°C	55	55	55	55
DC-link capacitance					
- Smart Line Module	µF	8400	12000	16800	18900
- Drive line-up, max.	µF	42000	60000	67200	75600
Power loss, max. ¹⁾					
- at 50 Hz 400 V	kW	3.7	4.7	7.1	11.0
- at 60 Hz 460 V	kW	3.7	4.7	7.1	11.0
Cooling air requirement	m ³ /s	0.36	0.36	0.78	1.08
Sound pressure level					
L_{pA} (1 m) at 50/60 Hz	dB(A)	69 / 73	69 / 73	70 / 73	70 / 73
Line/load connection		Flat connector for screw			
		M10	M10	M12	M12
Max. connection cross-sections					
- Line connection (U1, V1, W1)	mm ²	2 x 240	2 x 240	4 x 240	6 x 240
- DC-link connection (DCP, DCN)	mm ²	2 x 240	2 x 240	Busbar	Busbar
- PE connection PE1	mm ²	2 x 240	2 x 240	1 x 240	1 x 240
- PE connection PE2	mm ²	-	-	2 x 240	3 x 240
Max. cable length					
(total of all motor cables and DC link)					
- Shielded	m	4000	4000	4800	4800
- Unshielded	m	6000	6000	7200	7200

Article number	6SL3330-	6TE35-5AA3	6TE37-3AA3	6TE41-1AA3	6TE41-3AA3
Degree of protection		IP00	IP00	IP00	IP00
Dimensions					
- Width	mm	310	310	503	704
- Height	mm	1420	1420	1475	1480
- Depth	mm	550	550	550	550
Frame size		GX	GX	HX	JX
Weight, approx.	kg	150	150	294	458
Recommended fuse ²⁾		3NE1435-2	3NE1437-2	3NE1334-2	3NE1436-2
- Number per phase (connected in parallel)		1	1	2	2
- Rated current		560	710	500	630
- Frame size acc. to IEC 60269		3	3	3	3
Minimum short-circuit current ³⁾	A	6200	9200	10400	16000

1) The specified power loss is the maximum value at 100% capacity utilization. The value in normal operation is lower.

2) To achieve a UL-approved system, it is absolutely essential to use the fuse types specified in the table.

3) Minimum current required for reliable triggering of the protective devices.

4.3 Smart Line Modules

Table 4- 28 Technical data for Smart Line Modules, 3 AC 380 V ... 480 V, Part 2

Article number	6SL3330-	6TE41-7AA3			
Rated output - For I _{n_DC} (50 Hz, 400 V) - For I _{H_DC} (50 Hz, 400 V) - For I _{n_DC} (60 Hz, 460 V) - For I _{H_DC} (60 Hz, 460 V)	kW kW HP HP	800 730 1230 1125			
DC-link current - Rated current I _{n_DC} - Base load current I _{H_DC} - Maximum current I _{max_DC}	A A A	1700 1513 2550			
Infeed/regenerative feedback current - Rated current I _{n_E} - Maximum current I _{max_E}	A A	1430 2145			
Supply voltages - Line voltage - Line frequency - Electronic power supply - DC-link voltage	V _{ACrms} Hz V _{DC} V _{DC}	3 AC 380 -10% (-15% < 1 min) ... 3 AC 480 +10% 47 ... 63 Hz 24 (20.4 ... 28.8) 1.32 x U _{line} (partial load) / 1.30 x U _{line} (full load)			
Current consumption - Electronics current consumption (24 V DC) - Fan power consumption (at 400 V AC)	A A	1.7 5.4			
Max. precharging current (max. 3 s)	A	98			
Max. ambient temperature - Without derating - With derating	°C °C	40 55			
DC-link capacitance - Smart Line Module - Drive line-up, max.	µF µF	28800 115200			
Power loss, max. ¹⁾ - at 50 Hz 400 V - at 60 Hz 460 V	kW kW	11.5 11.5			
Cooling air requirement	m ³ /s	1.08			
Sound pressure level L _{pA} (1 m) at 50/60 Hz	dB(A)	70 / 73			
Line/load connection		Flat connector for screw M12			
Max. connection cross-sections - Line connection (U1, V1, W1) - DC-link connection (DCP, DCN) - PE connection PE1 - PE connection PE2	mm ² mm ² mm ² mm ²	6 x 240 Busbar 1 x 240 3 x 240			
Max. cable length (total of all motor cables and DC link) - Shielded - Unshielded	m m	4800 7200			
Degree of protection		IP00			

Article number	6SL3330–	6TE41–7AA3			
Dimensions					
- Width	mm	704			
- Height	mm	1480			
- Depth	mm	550			
Frame size		JX			
Weight, approx.	kg	458			
Recommended fuse ²⁾		3NE1448-2			
- Number per phase (connected in parallel)		2			
- Rated current		850			
- Frame size acc. to IEC 60269		3			
Minimum short-circuit current ³⁾	A	21000			

1) The specified power loss is the maximum value at 100% capacity utilization. The value in normal operation is lower.

2) To achieve a UL-approved system, it is absolutely essential to use the fuse types specified in the table.

3) Minimum current required for reliable triggering of the protective devices.

4.3 Smart Line Modules

Table 4- 29 Technical data for Smart Line Modules, 3 AC 500 to 690 V

Article number	6SL3330-	6TG35-5AA3	6TG38-8AA3	6TG41-2AA3	6TG41-7AA3
Rated power					
- For I_{n_DC} (50 Hz, 690 V)	kW	450	710	1000	1400
- For I_{H_DC} (50 Hz, 690 V)	kW	405	665	885	1255
- For I_{n_DC} (50 Hz, 500 V)	kW	320	525	705	995
- For I_{H_DC} (50 Hz, 500 V)	kW	295	480	640	910
- For I_{n_DC} (60 Hz, 575 V)	HP	500	790	1115	1465
- For I_{H_DC} (60 Hz, 575 V)	HP	450	740	990	1400
DC-link current					
- Rated current I_{n_DC}	A	550	900	1200	1700
- Base load current I_{H_DC}	A	490	800	1068	1513
- Maximum current I_{max_DC}	A	825	1350	1800	2550
Infeed/regenerative feedback current					
- Rated current I_{n_E}	A	463	757	1009	1430
- Maximum current I_{max_E}	A	694	1135	1513	2145
Supply voltages		3 AC 500 -10% (-15% < 1 min) ... 3 AC 690 +10%			
- Line voltage	V_{ACrms}	47 ... 63 Hz			
- Line frequency	Hz	24 (20.4 ... 28.8)			
- Electronic power supply	V_{DC}	1.32 x U_{line} (partial load) / 1.30 x U_{line} (full load)			
- DC-link voltage	V_{DC}				
Current consumption					
- Electronics current consumption (24 V DC)	A	1.35	1.4	1.5	1.7
- Fan power consumption (at 500 V AC / 690 V AC)	A	1.4 / 1.0	2.9 / 2.1	4.3 / 3.1	4.3 / 3.1
Max. precharging current (max. 3 s)	A	41	122	122	122
Max. ambient temperature					
- Without derating	°C	40	40	40	40
- With derating	°C	55	55	55	55
DC-link capacitance					
- Smart Line Module	μF	5600	7400	11100	14400
- Drive line-up, max.	μF	28000	29600	44400	57600
Power loss, max. ¹⁾					
- at 50 Hz 690 V	kW	4.3	6.5	12.0	13.8
- at 60 Hz 575 V	kW	4.3	6.5	12.0	13.8
Cooling air requirement	m^3/s	0.36	0.78	1.08	1.08
Sound pressure level					
L_{pA} (1 m) at 50/60 Hz	dB(A)	69 / 73	70 / 73	70 / 73	70 / 73
Line/load connection		Flat connector for screw			
		M10	M12	M12	M12
Max. connection cross-sections					
- Line connection (U1, V1, W1)	mm^2	2 x 240	4 x 240	6 x 240	6 x 240
- DC-link connection (DCP, DCN)	mm^2	2 x 240	Busbar	Busbar	Busbar
- PE connection PE1	mm^2	2 x 240	1 x 240	1 x 240	1 x 240
- PE connection PE2	mm^2	-	2 x 240	3 x 240	3 x 240
Max. cable length					
(total of all motor cables and DC link)					
- Shielded	m	2250	2750	2750	2750
- Unshielded	m	3375	4125	4125	4125
Degree of protection		IP00	IP00	IP00	IP00

Article number	6SL3330-	6TG35-5AA3	6TG38-8AA3	6TG41-2AA3	6TG41-7AA3
Dimensions					
- Width	mm	310	503	704	704
- Height	mm	1420	1475	1480	1480
- Depth	mm	550	550	550	550
Frame size		GX	HX	JX	JX
Weight, approx.	kg	150	294	458	458
Recommended fuse ²⁾		3NE1435-2	3NE1448-2	3NE1435-2	3NE1448-2
- Number per phase (connected in parallel)		1	1	2	2
- Rated current		560	850	560	850
- Frame size acc. to IEC 60269		3	3	3	3
Minimum short-circuit current ³⁾	A	6200	10500	12400	21000

- 1) The specified power loss is the maximum value at 100% capacity utilization. The value in normal operation is lower.
- 2) To achieve a UL-approved system, it is absolutely essential to use the fuse types specified in the table.
- 3) Minimum current required for reliable triggering of the protective devices.

Overload capability

The Smart Line Modules have an overload reserve.

The criterion for overload is that the Smart Line Module is operated with its base load current before and after the overload occurs (a load duration of 300 s is used as a basis here).

High overload

The base load current for a high overload I_{H_DC} is based on a duty cycle of 150% for 60 s; the max. current I_{max_DC} can flow for 5 s.

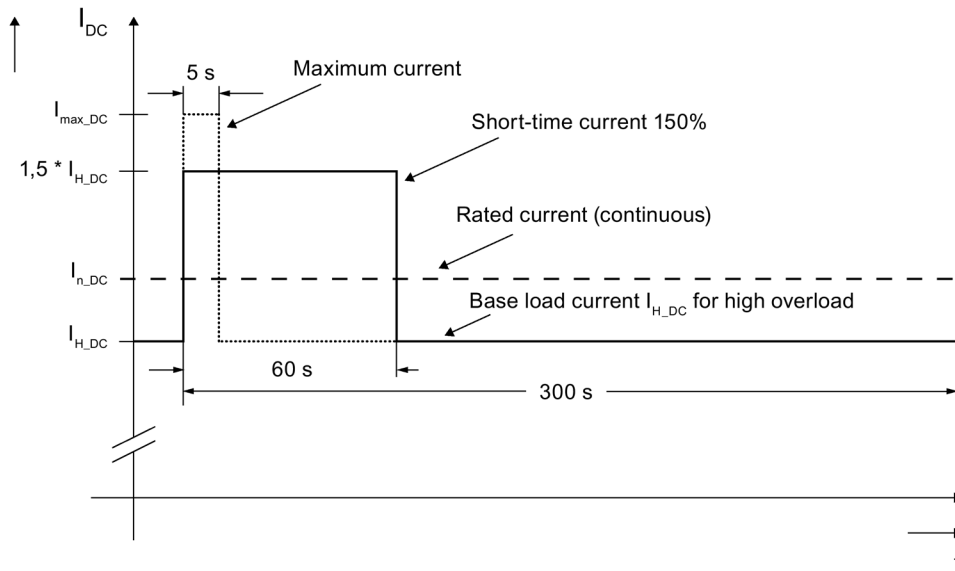

Figure 4-26 High overload

4.4 Active Line Modules

4.4.1 Description

The self-commutating infeed / regenerative feedback units act as step-up converters and generate a stabilized DC link voltage that is 1.5x greater (factory setting) than the rated line supply voltage. In this way, the connected Motor Modules are isolated from the line voltage. This improves the dynamic response and control quality because line tolerances and fluctuations do not affect the motor voltage.

If required, the Active Line Modules can also provide reactive power compensation.

Table 4- 30 Overview of Active Line Modules

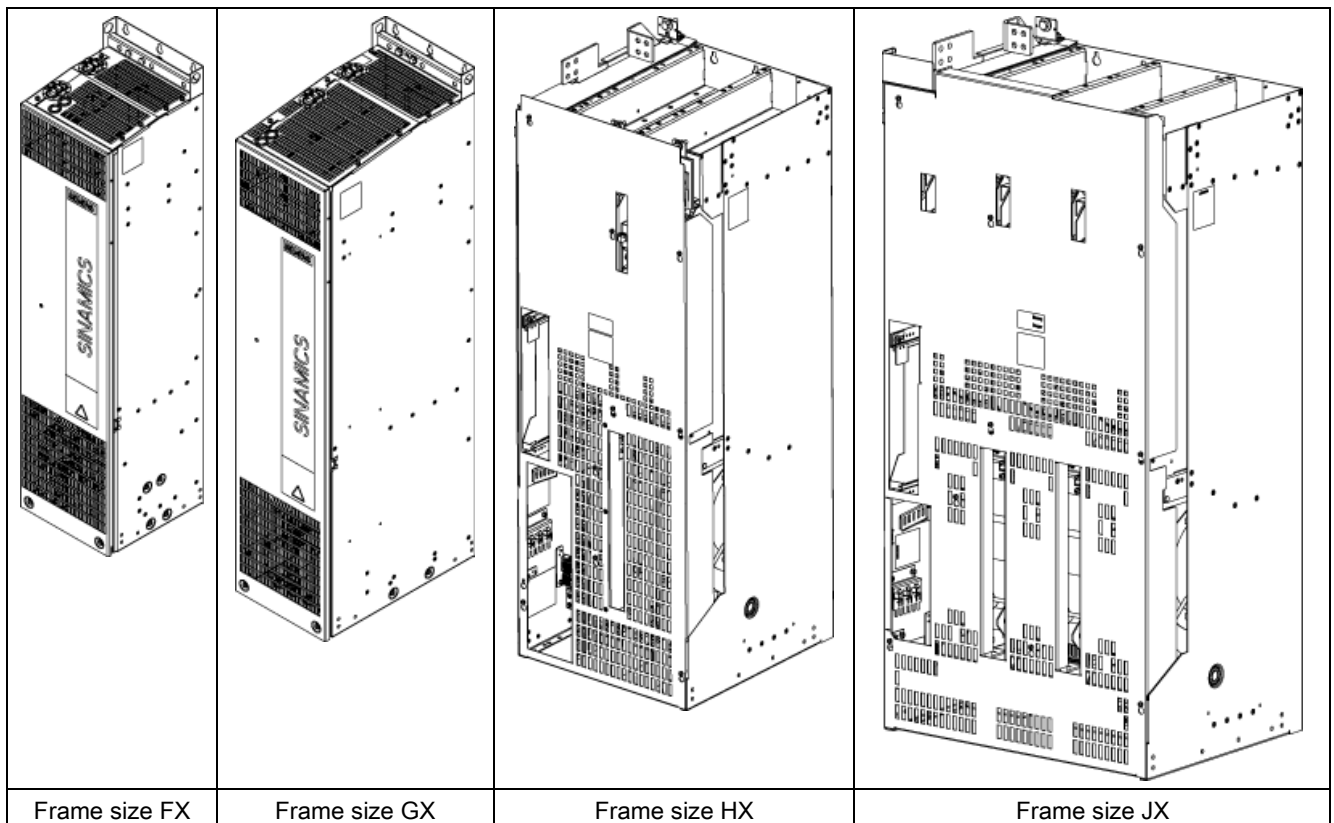

Active Infeed components

An Active Infeed comprises an Active Interface Module and an Active Line Module.

The bypass contactor is fitted in the relevant Active Interface Module on Active Infeeds which feature an Active Line Module of frame size FX or GX. The Active Interface Modules and Active Line Modules of these frame sizes have degree of protection IP20.

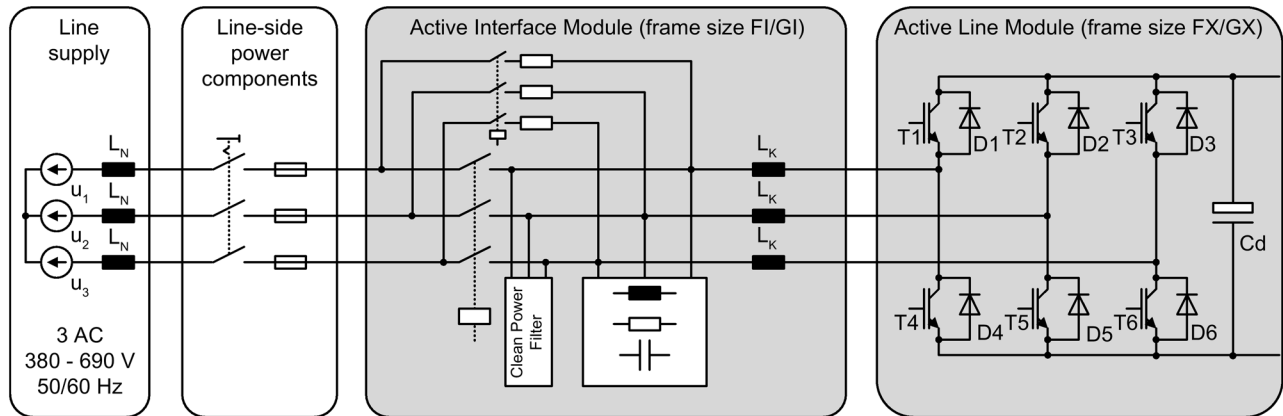

Figure 4-27 Overview of Active Infeed (frame sizes FI/FX and GI/GX)

In the case of an Active Infeed with an Active Line Module of frame sizes HX or JX, the bypass contactor is not included in the associated Active Interface Module, but must be provided separately. The Active Interface Modules and Active Line Modules of these frame sizes have degree of protection IP00.

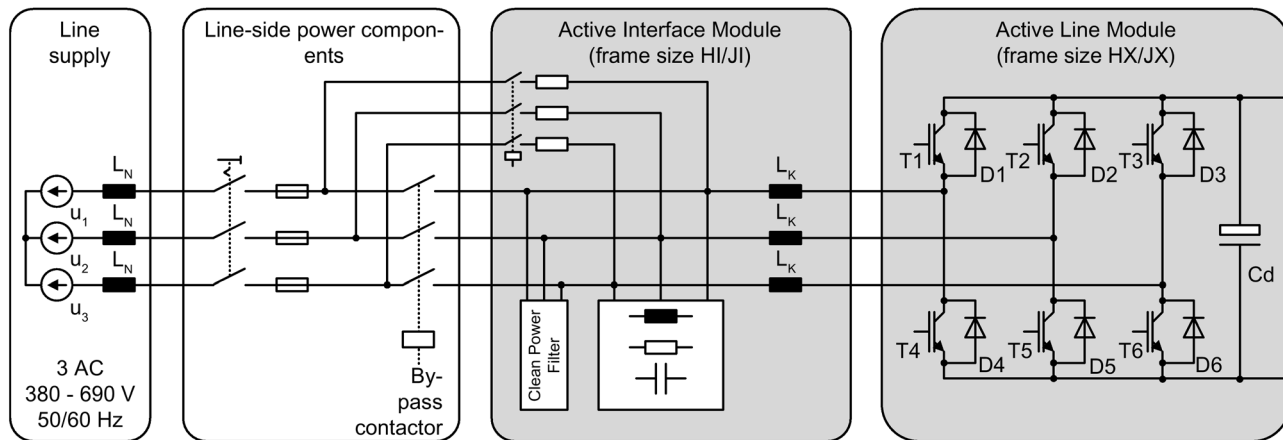

Figure 4-28 Overview of Active Infeed (frame sizes HI/HX and JI/JX)

Operating principle

One or more Motor Modules can be connected to the power supply network via the Active Line Module. The Active Line Module provides a constant DC-link voltage for the Motor Modules. This ensures that they are not influenced by line voltage fluctuations. The regenerative feedback capability of the Active Line Module can be deactivated by parameterization.

The Active Line Module is suitable for direct operation both on TN and on IT and TT systems.

With the motors operating as generators, the Active Line Module feeds regenerative energy into the supply network.

The Active Line Module is used for:

- Machines with high dynamic drive requirements
- Frequent braking cycles and high braking energy

Parallel connection of Active Line Modules to increase power rating

Up to four Active Line Modules with the same power rating can be connected in parallel in order to increase power.

The following rules must be observed when connecting Active Line Modules in parallel:

- Up to four identical Active Line Modules can be connected in parallel.
- A common Control Unit is required whenever the modules are connected in parallel.
- With multiple infeeds, power must be supplied to the systems from a common infeed point (i.e. different supply systems are not permitted).
- A derating factor of 5% must be taken into consideration, regardless of the number of modules connected in parallel.

Note

Mixed operation is not possible

It is only possible to connect identical power units in parallel if all power units have the same hardware version. Mixed operation between a power unit with Control Interface Module (article number 6SL33xx-xxxxx-xAA3) and a power unit with Control Interface Board (article number 6SL33xx-xxxxx-xAA0) is not possible.

4.4.2 Safety information

	WARNING
Not observing fundamental safety instructions and residual risks	
Not observing fundamental safety instructions and residual risks listed in Chapter 1 can result in accidents with severe injuries or death.	
<ul style="list-style-type: none"> • Comply with the fundamental safety instructions. • When assessing the risk, take into account remaining risks. 	



	DANGER
Electric shock due to a high DC link voltage	
As long as the Line Module is connected to the line supply, the DC link is charged with a high voltage. Contact with components can result in death or serious injury.	
<ul style="list-style-type: none"> • Isolate the Line Module from the line supply during installation of maintenance work, e.g. via the line contactor or main switch. 	



	WARNING
Electric shock or fire due to overcurrent protective equipment that trips too late	
Overcurrent protective devices that do not trip or trip too late can cause an electric shock or fire.	
<ul style="list-style-type: none"> • To protect personnel and for fire protection purposes, at the infeed point, the short-circuit rating and loop impedance must correspond to the specifications in the documentation in order for the installed overcurrent protection devices to trip within the specified time. 	



	WARNING
High leakage currents when the protective conductor in the line feeder cable is interrupted	
The drive components conduct a high leakage current via the protective conductor. Touching conductive parts when the protective conductor is interrupted can result in death or serious injury.	
<ul style="list-style-type: none"> • Ensure that the external protective conductor satisfies at least one of the following conditions: <ul style="list-style-type: none"> – It has been installed so that it is protected against mechanical damage. ¹⁾ – For an individual core, it has a cross-section of at least 10 mm² Cu. – If it is a conductor of a multi-conductor cable, it has a cross-section of at least 2.5 mm² Cu. – It has a second protective conductor in parallel with the same cross-section. – It complies with the local regulations for equipment with increased leakage current. <p>¹⁾ Cables laid within control cabinets or closed machine housings are considered to be adequately protected from mechanical damage.</p>	

⚠ WARNING**Fire due to inadequate ventilation clearances**

Inadequate ventilation clearances can cause overheating with a risk for personnel through smoke development and fire. This can also result in more downtimes and reduced service lives of Line Modules.

- Observe the ventilation clearances above, below, and in front of the Line Modules, which are specified in the dimension drawings.

⚠ CAUTION**Fire due to overheating when the total length of the power cables is exceeded**

Overheating and a fire can result when the total length of the power cables is exceeded.

- Ensure that the total length of the power cables (motor feeder cables and DC link cables) does not exceed the values specified in the technical data.

NOTICE**Material damage caused by the failure to remove linkage levers for devices of frame sizes HX and JX**

The failure to remove linkage levers from devices of frame sizes HX and JX can cause damage to the device as a result of undershooting the necessary voltage clearances.

- For devices of frame sizes HX and JX, remove the linkage levers marked in red once the devices have been installed.

NOTICE**Material damage caused by loose power connections**

Insufficient tightening torques or vibration can result in faulty electrical connections. This can cause fire damage or malfunctions.

- Tighten all power connections with the specified tightening torques, e.g. line supply connection, motor connection, DC link connections.
- Check the tightening torques of all power connections at regular intervals and tighten them when required. This applies in particular after transport.

NOTICE**Damage to the devices when performing a voltage test as a result of connections that are not disconnected**

As part of routine tests, SINAMICS S components undergo a voltage test according to EN 61800-5-1. Connected devices can be damaged.

- Disconnect or unplug all SINAMICS devices before the voltage test of the machine equipment according to EN 60204-1, Section 18.4.

NOTICE

Damage through use of incorrect DRIVE-CLiQ cables

Damage or malfunctions can occur on the devices or system when DRIVE-CLiQ cables are used that are either incorrect or have not been released for this purpose.

- Only use suitable DRIVE-CLiQ cables that have been released by Siemens for the particular application.

Note

Operation on line supplies where energy recovery is not possible

In line supply systems without energy recovery capability (e.g. a diesel generator), device faults can occur as the braking energy cannot be dissipated.

- For line supplies without regenerative feedback capability (e.g. diesel generator), deactivate the regenerative feedback capability of the Line Modules using the appropriate parameter (see SINAMICS S120/S150 List Manual).
 - The braking energy must then be dissipated via an additional Braking Module with braking resistor in the drive line-up.
-

4.4.3 Interface description

4.4.3.1 Overview

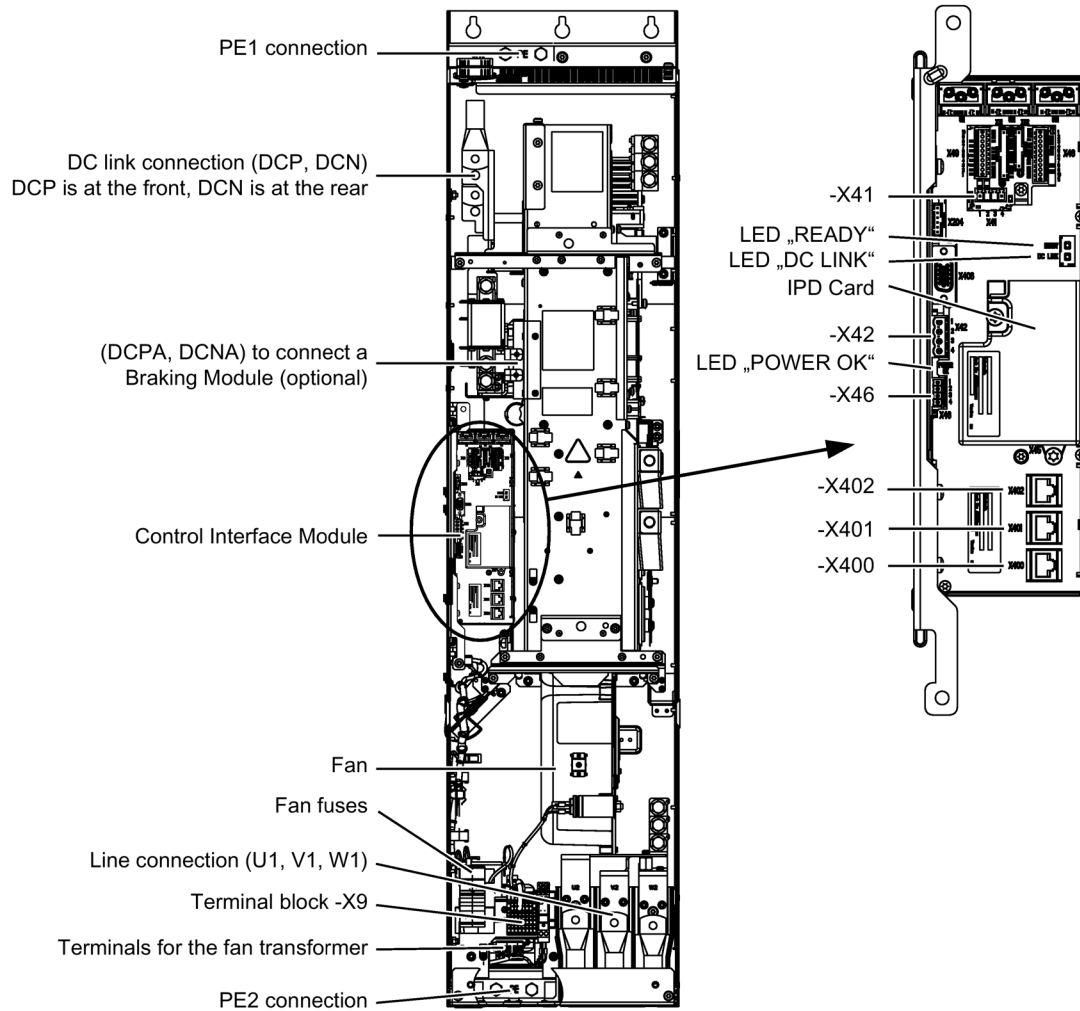

Figure 4-29 Active Line Module, frame size FX

4.4 Active Line Modules

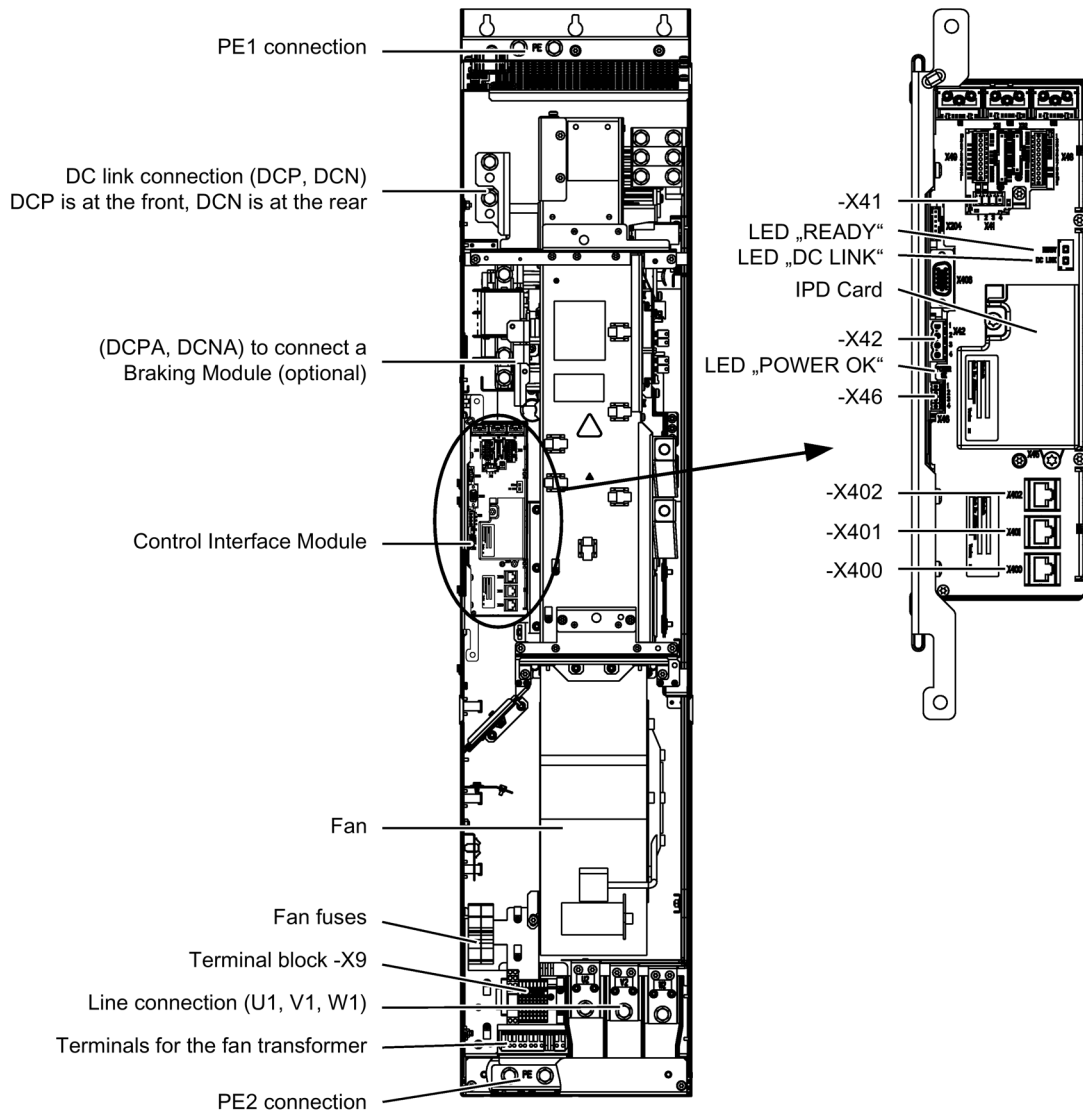

Figure 4-30 Active Line Module, frame size GX

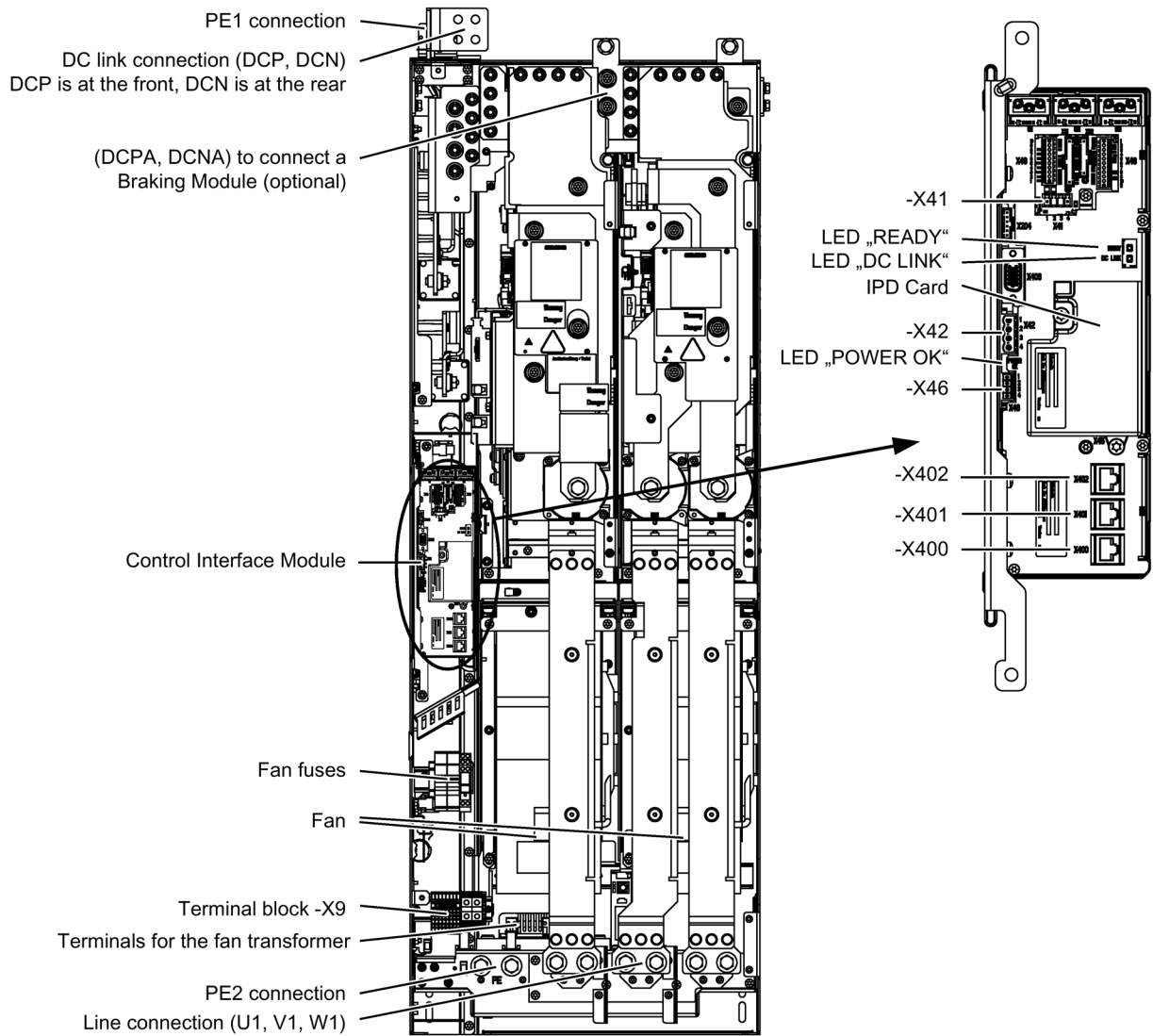

Figure 4-31 Active Line Module, frame size HX

4.4 Active Line Modules

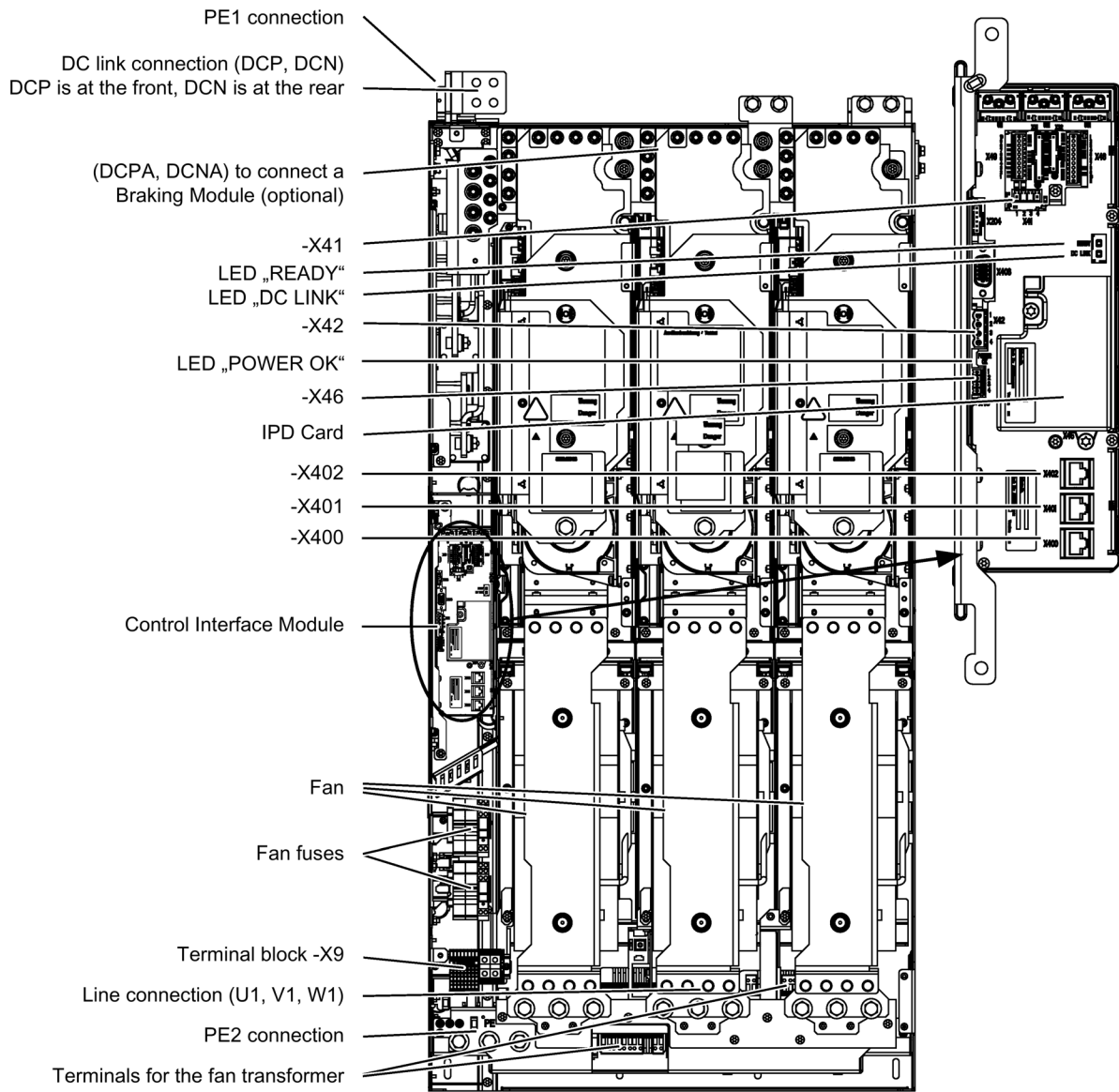

Figure 4-32 Active Line Module, frame size JX

4.4.3.2 Connection example

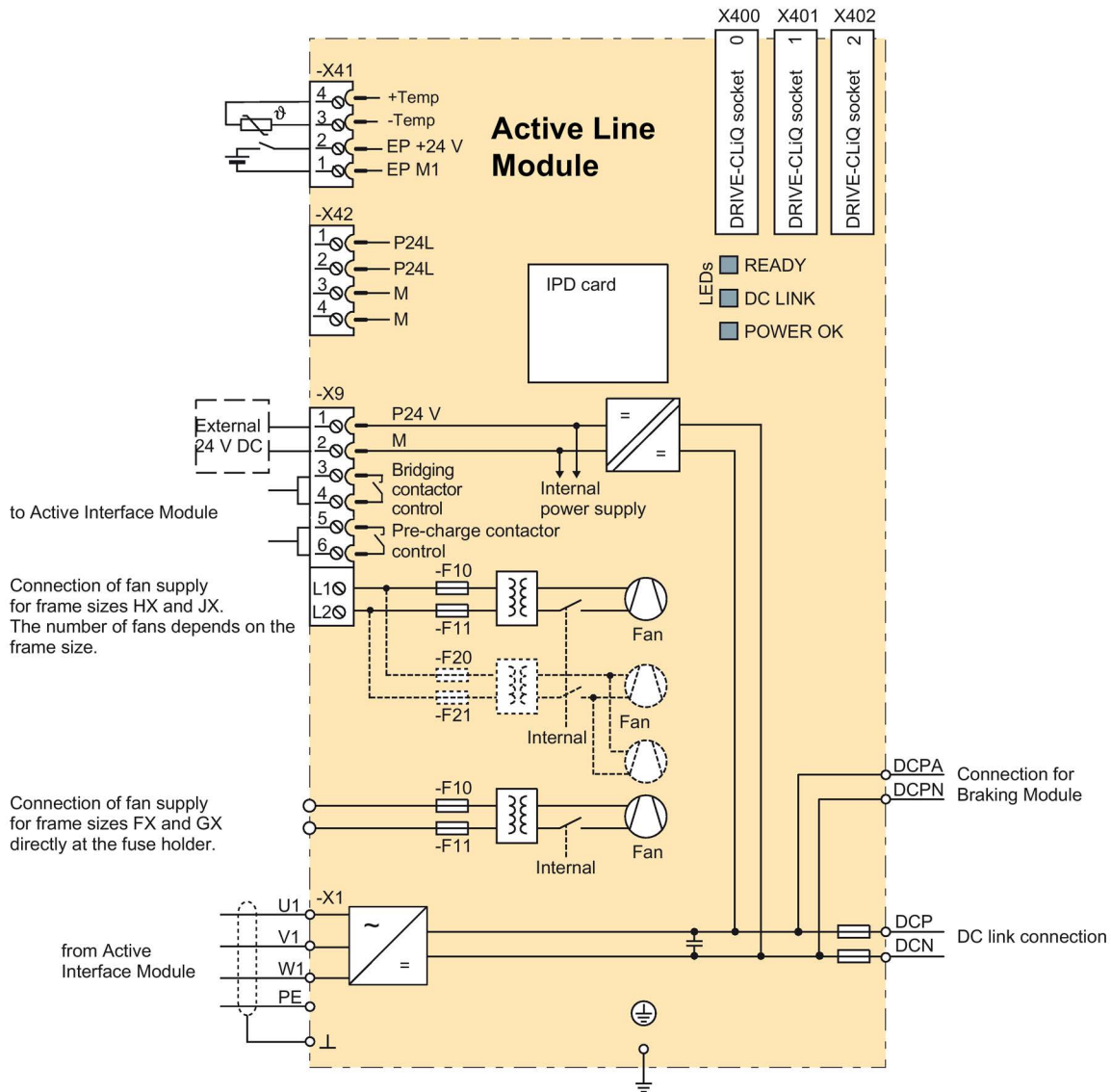

Figure 4-33 Active Line Module wiring diagram

4.4.3.3 Line/load connection

Table 4- 31 Line/load connection of the Active Line Module

Terminals	Technical specifications
U1, V1, W1 3 AC power input	Voltage: <ul style="list-style-type: none"> • 3 AC 380 V -10% (-15% < 1 min) ... 3 AC 480 V +10% • 3 AC 500 V -10% (-15% < 1 min) ... 3 AC 690 V +10% Frequency: 47 ... 63 Hz Connecting thread: <ul style="list-style-type: none"> • Frame sizes FX/GX: M10 / 25 Nm for cable lugs in accordance with DIN 46234 / DIN 46235 ¹⁾ • Frame sizes HX/JX: M12 / 50 Nm for cable lugs in accordance with DIN 46234 / DIN 46235 ¹⁾
DCPA, DCNA Connection for Braking Module	Voltage: <ul style="list-style-type: none"> • 570 ... 720 V DC • 750 ... 1035 V DC Connections: <ul style="list-style-type: none"> • Frame sizes FX/GX: Threaded bolts M6 / 6 Nm for cable lugs in accordance with DIN 46234 / DIN 46235 ¹⁾ • Frame sizes HX/JX: Connection for connection clip
DCP, DCN DC power output	Voltage: <ul style="list-style-type: none"> • 570 ... 720 V DC • 750 ... 1035 V DC Connections: <ul style="list-style-type: none"> • Frame sizes FX/GX: Thread M10 / 25 Nm for cable lugs in accordance with DIN 46234 / DIN 46235 ¹⁾ • Frame sizes HX/JX: d = 12 mm (M10 / 25 Nm) flat connector for busbar connection
PE connection PE1, PE2	Connecting thread: <ul style="list-style-type: none"> • Frame sizes FX/GX: M10 / 25 Nm for cable lugs in accordance with DIN 46234 / DIN 46235 ¹⁾ • Frame sizes HX/JX: M12 / 50 Nm for cable lugs in accordance with DIN 46234 / DIN 46235 ¹⁾

¹⁾ Dimensions for connecting alternative cable lugs, see "cable lugs" in the appendix.

4.4.3.4 X9 terminal strip

Table 4- 32 Terminal strip X9

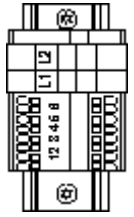
	Terminal	Signal name	Technical specifications
	1	P24V	External 24 V DC supply Voltage: 24 V DC (20.4 ... 28.8 V) Current consumption: max. 1.7 A
	2	M	
	3	Bypass contactor control	for Active Interface Module, X609:11
	4		for Active Interface Module, X609:12
	5	Pre-charge contactor control	for Active Interface Module, X609:9
	6		for Active Interface Module, X609:10
	L1	Connection for fan supply (frame sizes HX and JX only)	380 ... 480 V AC / 500 ... 690 V AC Current consumption: See Technical data
L2			
Max. connectable cross-section: - terminal 1 ... 6: 2.5 mm ² - terminals L1, L2: 35 mm ²			

Note

Connecting fan supply, with frame sizes FX and GX

The fan supply for frame sizes FX and GX is connected directly to fuse holders -F10 and -F11.

4.4.3.5 X41 EP terminal / temperature sensor connection

Table 4- 33 Terminal strip X41

	Terminal	Function	Technical specifications
	1	EP M1 (Enable Pulses)	Supply voltage: 24 V DC (20.4 ... 28.8 V) Current consumption: 10 mA
	2	EP +24 V (Enable Pulses)	
	3	- Temp	Temperature sensor connection KTY84-1C130 / PT1000 / PTC
	4	+ Temp	
Max. connectable cross-section: 1.5 mm ²			



! WARNING
Electric shock in the event of voltage flashovers at the temperature sensor
Voltage flashovers in the signal electronics can occur in motors without safe electrical separation of the temperature sensors.
<ul style="list-style-type: none">• Only use temperature sensors that fully comply with the specifications of the safety isolation.• If safe electrical separation cannot be guaranteed (for linear motors or third-party motors, for example), use a Sensor Module External (SME120 or SME125) or Terminal Module TM120.

NOTICE
Device failure as a result of unshielded or incorrectly routed cables to temperature sensors
Unshielded or incorrectly routed cables to temperature sensors can result in interference being coupled into the signal processing electronics from the power side. This can result in significant disturbance of all signals (fault messages) up to failure of individual components (destruction of the devices).
<ul style="list-style-type: none">• Only use shielded cables as temperature sensor cables.• If temperature sensor cables are routed together with the motor cable, use separately shielded cables twisted in pairs.• Connect the cable shield to ground potential through a large surface area.• Recommendation: Use the appropriate MOTION-CONNECT cables.

NOTICE
Damage to motor in the event of incorrectly connected KTY temperature sensor
If a KTY temperature sensor is connected with incorrect polarity, it is not possible to detect when the motor overheats. Overheating can cause damage to the motor.
<ul style="list-style-type: none">• Connect a KTY temperature sensor with the correct polarity.

Note

The temperature sensor connection can be used for motors that are equipped with a KTY84-1C130, PT1000 or PTC measuring sensor in the stator windings.

Note

Connection to terminals 1 and 2

For operation, 24 V DC must be connected to terminal 2 and ground to terminal 1. Pulse suppression is activated when removed.

Note

If circuit breakers or contactors - which are closed from a higher-level control when the pulses are enabled - are connected upstream of the Active Line Module, then these should be incorporated in the EP terminal circuit via their auxiliary contacts. This prevents the filter from oscillating when switching under no-load conditions.

4.4.3.6 X42 terminal strip

Table 4- 34 Terminal strip X42 voltage supply for Control Unit, Sensor Module and Terminal Module

	Terminal	Function	Technical specifications
	1	P24L	Voltage supply for Control Unit, Sensor Module and Terminal Module (18 to 28.8 V) maximum load current: 3 A
	2		
	3	M	
	4		
Max. connectable cross-section: 2.5 mm ²			

Note

Connection options for terminal strip X42

The terminal strip is not intended for free 24 V DC availability (for example for supplying further line-side components), as the voltage supply of the Control Interface Module could also be overloaded and operating capability could thus be compromised.

4.4.3.7 DRIVE-CLiQ interfaces X400, X401, X402

Table 4- 35 DRIVE-CLiQ interfaces X400, X401, X402

	PIN	Signal name	Technical specifications
	1	TXP	Transmit data +
	2	TXN	Transmit data -
	3	RXP	Receive data +
	4	Reserved, do not use	
	5	Reserved, do not use	
	6	RXN	Receive data -
	7	Reserved, do not use	
	8	Reserved, do not use	
	A	+ (24 V)	24 V power supply
	B	M (0 V)	Electronics ground
Blanking plate for DRIVE-CLiQ interfaces (50 pcs.) Article number: 6SL3066-4CA00-0AA0			

4.4.3.8 Meaning of the LEDs on the Control Interface Module in the Active Line Module

Table 4- 36 Meaning of the LEDs "READY" and "DC LINK" on the Control Interface Module in the Active Line Module

LED state		Description
READY	DC LINK	
Off	Off	The electronics power supply is missing or out of tolerance.
Green	--- ¹⁾	The component is ready for operation and cyclic DRIVE-CLiQ communication is taking place.
	Orange	The component is ready for operation and cyclic DRIVE-CLiQ communication is taking place. The DC-link voltage is present.
	Red	The component is ready for operation and cyclic DRIVE-CLiQ communication is taking place. The DC link voltage lies outside the permitted tolerance range.
Orange	Orange	DRIVE-CLiQ communication is being established.
Red	--- ¹⁾	This component has at least one fault. Remark: The LED is activated irrespective of whether the corresponding messages have been reconfigured.
Flashing light 0.5 Hz: green/red	--- ¹⁾	Firmware is being downloaded.
Flashing light 2 Hz: green/red	--- ¹⁾	Firmware download is complete. Waiting for POWER ON.
Flashing light 2 Hz: green/orange or red/orange	--- ¹⁾	Detection of the components via LED is activated (p0124). Note: Both options depend on the LED status when module recognition is activated via p0124 = 1.

¹⁾ Irrespective of the status of the LED "DC LINK"

Table 4- 37 Meaning of the LED "POWER OK" on the Control Interface Module in the Active Line Module

LED	Color	Status	Description
POWER OK	Green	Off	DC link voltage or control voltage at -X9 too low.
		On	The component is ready for operation.
		Flashing light	There is a fault. If the LED continues to flash after you have performed a POWER ON, please contact your Siemens service center.



 WARNING
<p>Electric shock when live parts of the DC link are touched</p> <p>Hazardous DC link voltages may be present at any time regardless of the status of the "DC LINK" LED. This means that when live parts are touched, this can result in death or serious injury.</p> <ul style="list-style-type: none"> Observe the warning information on the component.

4.4.4 Dimension drawing

Dimension drawing, frame size FX

The mandatory cooling clearances are indicated by the dotted line.

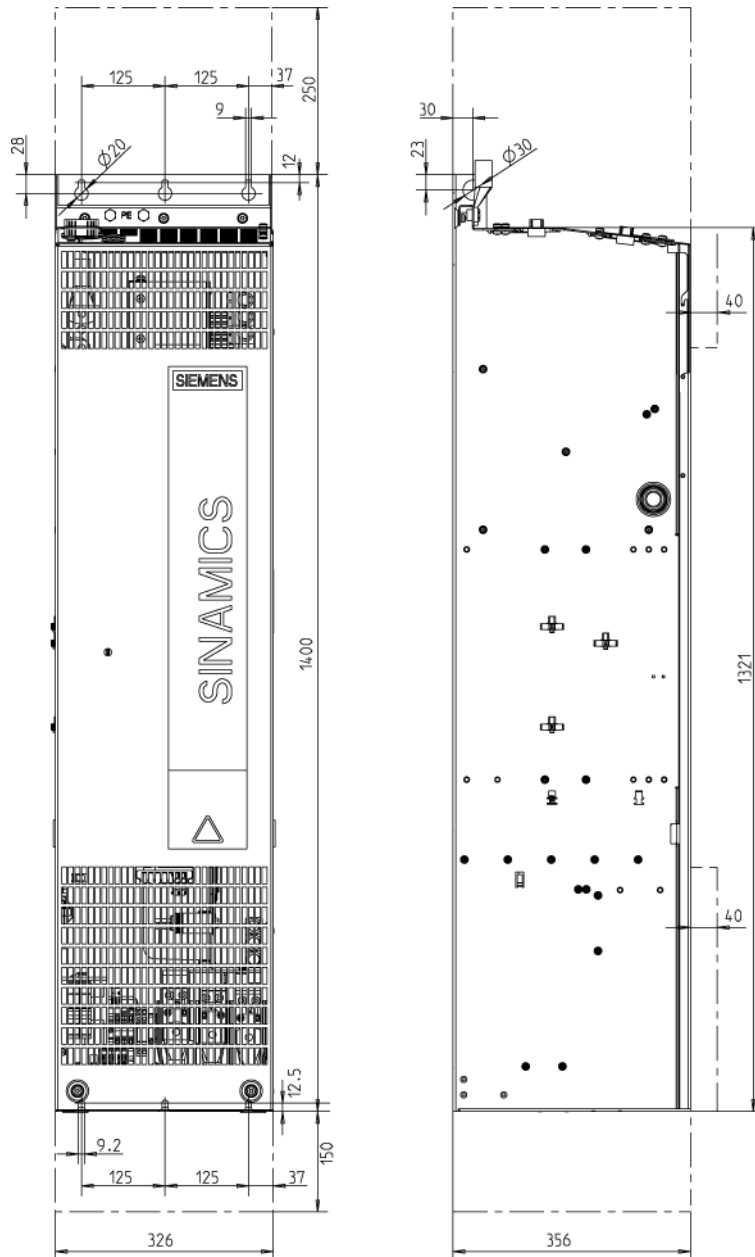

Figure 4-34 Dimension drawing Active Line Module, frame size FX. Front view, side view

Dimension drawing, frame size GX

The mandatory cooling clearances are indicated by the dotted line.

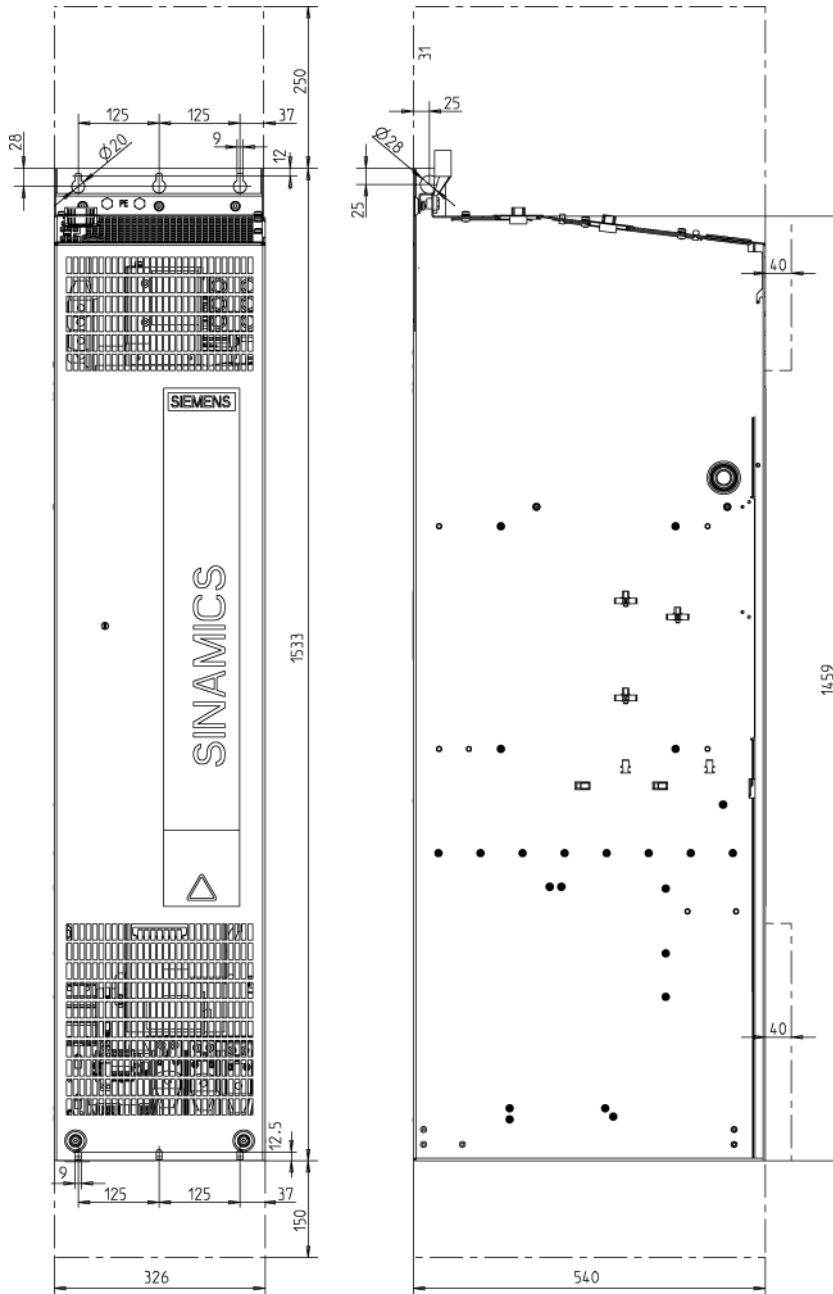

Figure 4-35 Dimension drawing Active Line Module, frame size GX. Front view, side view

Dimension drawing, frame size HX

The mandatory cooling clearances are indicated by the dotted line.

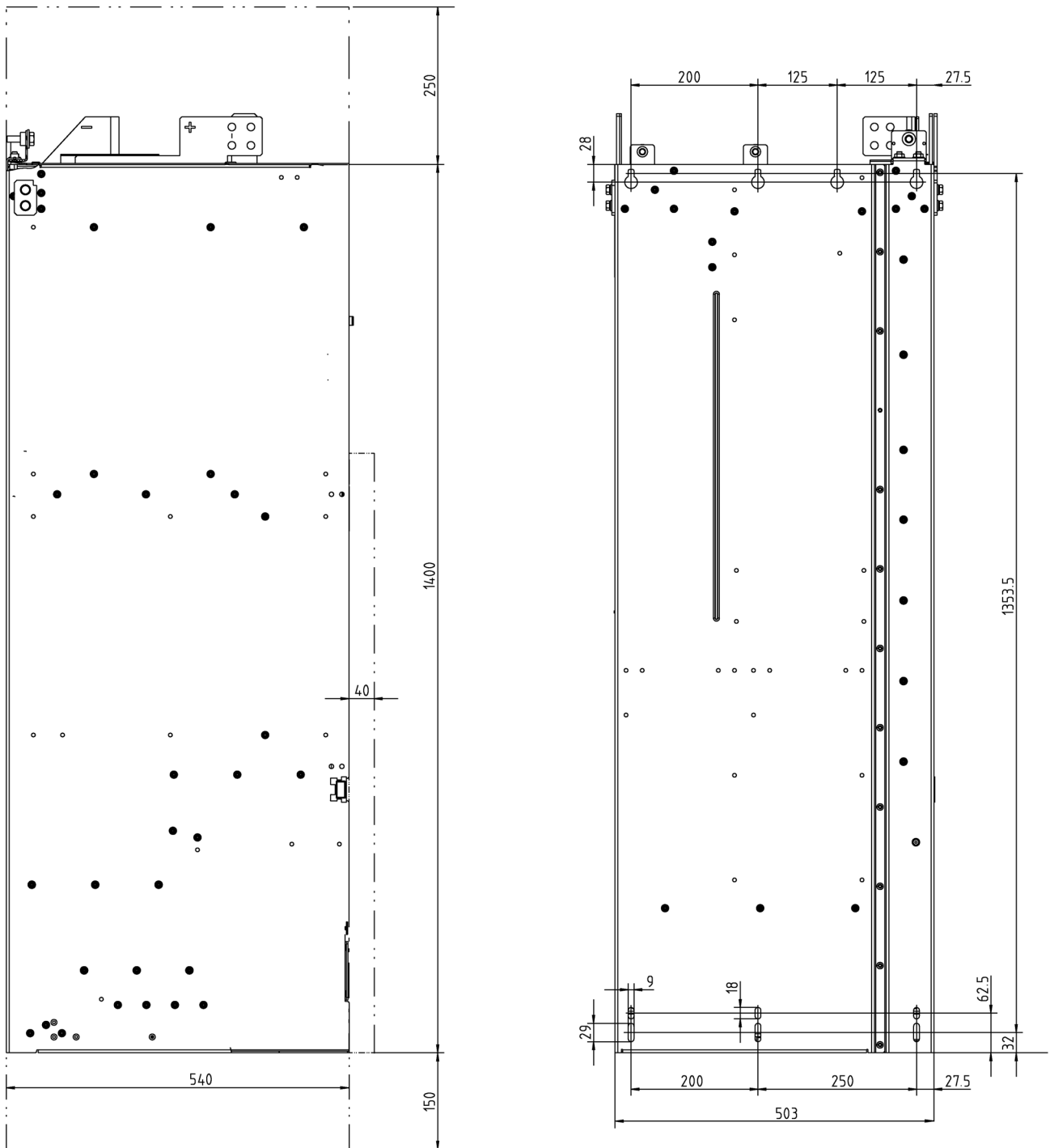

Figure 4-36 Dimension drawing Active Line Module, frame size HX. Side view, rear view

Dimension drawing, frame size JX

The mandatory cooling clearances are indicated by the dotted line.

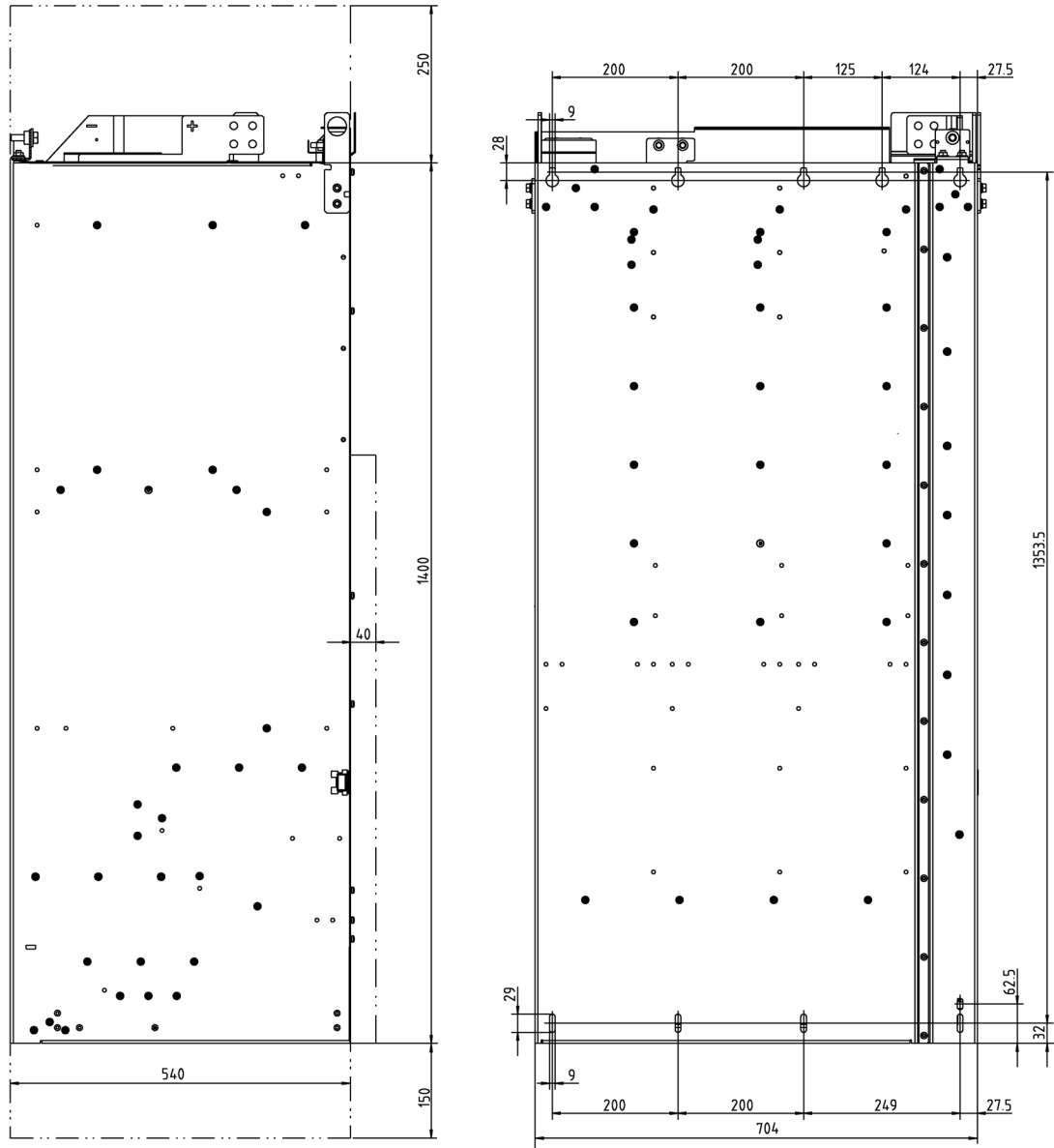

Figure 4-37 Dimension drawing Active Line Module, frame size JX. Side view, rear view

4.4.5 Electrical connection

Adjusting the fan voltage (-T10)

The power supply for the device fans (1 AC 230 V) in the Active Line Module (-T10) is taken from the line supply using transformers. The locations of the transformers are indicated in the interface descriptions.

The transformers are fitted with primary taps so that they can be fine-tuned to the line supply voltage.

If necessary, the connection fitted in the factory, shown with a dashed line, must be reconnected to the actual line voltage.

Note

Two transformers (-T10 and -T20) are installed in Active Line Modules, frame size JX. The two primary-side terminals on each of these devices must be adjusted together.

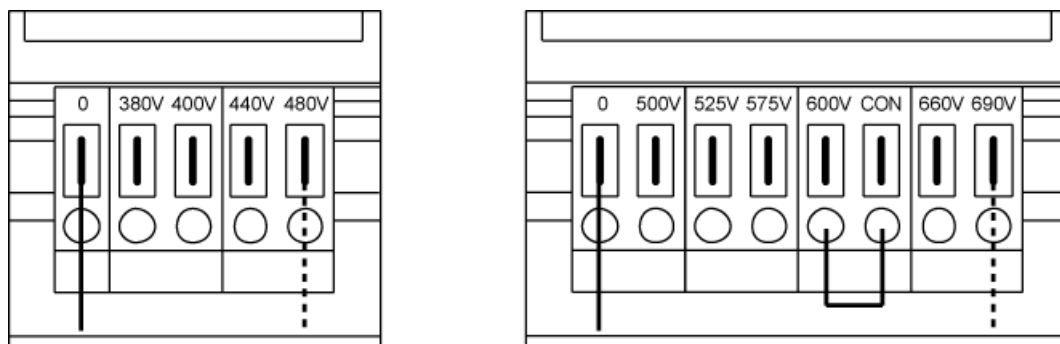

Figure 4-38 Setting terminals for the fan transformers (3 AC 380 to 480 V / 3 AC 500 to 690 V)

The supply voltage assignments for making the appropriate setting on the fan transformer are indicated in the following tables (factory presetting: 480 V / 0 V or 690 V / 0 V).

Note

With the 3 AC 500 V to 690 V fan transformer, a jumper is inserted between the "600 V" terminal and "CON" terminal. The jumper between terminal "600 V" and "CON" is for internal use.

WARNING

Fire due to overheating resulting from insufficient equipment fan voltage

If the terminals are not reconnected to the actual line voltage, overheating and human danger due to smoke and fire may result.

This can also cause the fan fuses to blow due to overload.

- Set the terminals in accordance with the actual line voltage.

4.4 Active Line Modules

Table 4- 38 Line voltage assignment for the setting at the fan transformer
(3-phase 380 ... 480 V AC)

Line voltage	Tap at the fan transformer (-T10)
380 V ± 10%	380 V
400 V ± 10%	400 V
440 V ± 10%	440 V
480 V ± 10%	480 V

Table 4- 39 Line voltage assignment for the setting at the fan transformer
(3-phase 500 ... 690 V AC)

Line voltage	Tap at the fan transformer (-T10)
500 V ± 10%	500 V
525 V ± 10%	525 V
575 V ± 10%	575 V
600 V ± 10%	600 V
660 V ± 10%	660 V
690 V ± 10%	690 V

4.4.6 Technical specifications

Table 4- 40 Technical data for Active Line Modules, 3 AC 380 V ... 480 V, Part 1

Article number	6SL3330-	7TE32-1AA3	7TE32-6AA3	7TE33-8AA3	7TE35-0AA3
Rated output					
- For I_{n_DC} (50 Hz, 400 V)	kW	132	160	235	300
- For I_{H_DC} (50 Hz, 400 V)	kW	115	145	210	270
- For I_{n_DC} (60 Hz, 460 V)	HP	200	250	400	500
- For I_{H_DC} (60 Hz, 460 V)	HP	150	200	300	400
DC-link current					
- Rated current I_{n_DC}	A	235	291	425	549
- Base load current I_{H_DC}	A	209	259	378	489
- Maximum current I_{max_DC}	A	352	436	637	823
Infeed/regenerative feedback current					
- Rated current I_{n_E}	A	210	260	380	490
- Maximum current I_{max_E}	A	315	390	570	735
Supply voltages		3AC 380 -10% (-15% < 1 min) ... 3AC 480 +10%			
- Line voltage	V_{ACrms}				
- Line frequency	Hz				
- Electronic power supply	V_{DC}				
- DC-link voltage	V_{DC}	24 (20.4 ... 28.8) 1.5 x U_{line}			
Pulse frequency	kHz	4	4	4	4
Current consumption					
- Electronics current consumption (24 V DC)	A	1.1	1.1	1.35	1.35
- Total fan current consumption (at 400 V AC)	A	0.63	1.13	1.8	1.8
Max. ambient temperature					
- Without derating	°C	40	40	40	40
- With derating	°C	55	55	55	55
DC link capacitance					
- Active Line Module	µF	4200	5200	7800	9600
- Drive line-up, max.	µF	41600	41600	76800	76800
Power loss ¹⁾					
- At 50 Hz 400 V	kW	2.2	2.7	3.9	4.8
- At 60 Hz 460 V	kW	2.3	2.9	4.2	5.1
Cooling air requirement	m ³ /s	0.17	0.23	0.36	0.36
Sound pressure level ²⁾					
L_{pA} (1 m) at 50/60 Hz	dB(A)	64 / 67	71 / 71	69 / 73	69 / 73
Line/load connection		Flat connector for screw			
		M10	M10	M10	M10
Max. connection cross-sections					
- Line connection (U1, V1, W1)	mm ²	2 x 185	2 x 185	2 x 240	2 x 240
- DC-link connection (DCP, DCN)	mm ²	2 x 185	2 x 185	2 x 240	2 x 240
- PE connection PE1	mm ²	2 x 185	2 x 185	2 x 240	2 x 240
- PE connection PE2	mm ²	2 x 185	2 x 185	2 x 240	2 x 240
Max. cable length					
(total of all motor cables and DC link)					
- Shielded	m	2700	2700	2700	2700
- Unshielded	m	4050	4050	4050	4050

4.4 Active Line Modules

Article number	6SL3330-	7TE32-1AA3	7TE32-6AA3	7TE33-8AA3	7TE35-0AA3
Degree of protection		IP20	IP20	IP20	IP20
Dimensions					
- Width	mm	326	326	326	326
- Height	mm	1400	1400	1533	1533
- Depth	mm	356	356	545	545
Frame size		FX	FX	GX	GX
Weight	kg	95	95	136	136
Recommended fuse ³⁾		3NE1230-2	3NE1331-2	3NE1334-2	3NE1436-2
- Number per phase (connected in parallel)		1	1	1	1
- Rated current		315	350	500	630
- Frame size acc. to IEC 60269		2	2	3	3
Minimum short-circuit current ⁴⁾	A	6200	10500	10500	8000

- 1) The specified power loss is the maximum value at 100% capacity utilization. The value in normal operation is lower.
- 2) Total sound pressure level of Active Interface Module and Active Line Module.
- 3) To achieve a UL-approved system, it is absolutely essential to use the fuse types specified in the table.
- 4) Minimum current required for reliable triggering of the protective devices.

Table 4- 41 Technical data for Active Line Modules, 3 AC 380 V ... 480 V, Part 2

Article number	6SL3330-	7TE36-1AA3	7TE37-5AA3	7TE38-4AA3	7TE41-0AA3
Rated output					
- For I_{n_DC} (50 Hz, 400 V)	kW	380	450	500	630
- For I_{H_DC} (50 Hz, 400 V)	kW	335	400	465	545
- For I_{n_DC} (60 Hz, 460 V)	HP	600	600	700	900
- For I_{H_DC} (60 Hz, 460 V)	HP	500	600	700	800
DC-link current					
- Rated current I_{n_DC}	A	678	835	940	1103
- Base load current I_{H_DC}	A	603	700	837	982
- Maximum current I_{max_DC}	A	1017	1252	1410	1654
Infeed/regenerative feedback current					
- Rated current I_{n_E}	A	605	745	840	985
- Maximum current I_{max_E}	A	907	1117	1260	1477
Supply voltages		3AC 380 -10% (-15% < 1 min) ... 3AC 480 +10%			
- Line voltage	V_{ACrms}				
- Line frequency	Hz				
- Electronic power supply	V_{DC}				
- DC-link voltage	V_{DC}	24 (20.4 ... 28.8) 1.5 x U_{line}			
Pulse frequency	kHz	2.5	2.5	2.5	2.5
Current consumption					
- Electronics current consumption (24 V DC)	A	1.4	1.4	1.4	1.5
- Total fan current consumption (at 400 V AC)	A	3.6	3.6	3.6	5.4
Max. ambient temperature					
- Without derating	°C	40	40	40	40
- With derating	°C	55	55	55	55
DC link capacitance					
- Active Line Module	µF	12600	15600	16800	18900
- Drive line-up, max.	µF	134400	134400	134400	230400
Power loss ¹⁾					
- At 50 Hz 400 V	kW	6.2	7.3	7.7	10.1
- At 60 Hz 460 V	kW	6.6	7.7	8.2	10.8
Cooling air requirement	m ³ /s	0.78	0.78	0.78	1.08
Sound pressure level ²⁾					
L_{pA} (1 m) at 50/60 Hz	dB(A)	70 / 73	70 / 73	70 / 73	71 / 73
Line/load connection		Flat connector for screw			
		M12	M12	M12	M12
Max. connection cross-sections					
- Line connection (U1, V1, W1)	mm ²	4 x 240	4 x 240	4 x 240	6 x 240
- DC-link connection (DCP, DCN)	mm ²	Busbar	Busbar	Busbar	Busbar
- PE connection PE1	mm ²	1 x 240	1 x 240	1 x 240	1 x 240
- PE connection PE2	mm ²	2 x 240	2 x 240	2 x 240	3 x 240
Max. cable length (total of all motor cables and DC link)					
- Shielded	m	3900	3900	3900	3900
- Unshielded	m	5850	5850	5850	5850
Degree of protection		IP00	IP00	IP00	IP00

4.4 Active Line Modules

Article number	6SL3330-	7TE36-1AA3	7TE37-5AA3	7TE38-4AA3	7TE41-0AA3
Dimensions					
- Width	mm	503	503	503	704
- Height	mm	1475	1475	1475	1480
- Depth	mm	540	540	540	550
Frame size		HX	HX	HX	JX
Weight	kg	290	290	290	450
Recommended fuse ³⁾		3NE1438-2	3NE1333-2	3NE1334-2	3NE1436-2
- Number per phase (connected in parallel)		1	2	2	2
- Rated current		800	450	500	630
- Frame size acc. to IEC 60269		3	2	3	3
Minimum short-circuit current ⁴⁾	A	9200	8800	10400	16000

- 1) The specified power loss is the maximum value at 100% capacity utilization. The value in normal operation is lower.
- 2) Total sound pressure level of Active Interface Module and Active Line Module.
- 3) To achieve a UL-approved system, it is absolutely essential to use the fuse types specified in the table.
- 4) Minimum current required for reliable triggering of the protective devices.

Table 4- 42 Technical data for Active Line Modules, 3 AC 380 V ... 480 V, Part 3

Article number	6SL3330-	7TE41-2AA3	7TE41-4AA3		
Rated output					
- For I_{n_DC} (50 Hz, 400 V)	kW	800	900		
- For I_{H_DC} (50 Hz, 400 V)	kW	690	780		
- For I_{n_DC} (60 Hz, 460 V)	HP	1000	1250		
- For I_{H_DC} (60 Hz, 460 V)	HP	900	1000		
DC-link current					
- Rated current I_{n_DC}	A	1412	1574		
- Base load current I_{H_DC}	A	1255	1401		
- Maximum current I_{max_DC}	A	2120	2361		
Infeed/regenerative feedback current					
- Rated current I_{n_E}	A	1260	1405		
- Maximum current I_{max_E}	A	1890	2107		
Supply voltages		3AC 380 -10% (-15% < 1 min) ... 3AC 480 +10%			
- Line voltage	V_{ACrms}	47 ... 63Hz			
- Line frequency	Hz	24 (20.4 ... 28.8)			
- Electronic power supply	V_{DC}	1.5 x U_{line}			
- DC-link voltage	V_{DC}				
Pulse frequency	kHz	2.5	2.5		
Current consumption					
- Electronics current consumption (24 V DC)	A	1.7	1.7		
- Total fan current consumption (at 400 V AC)	A	5.4	5.4		
Max. ambient temperature					
- Without derating	°C	40	40		
- With derating	°C	55	55		
DC link capacitance					
- Active Line Module	µF	26100	28800		
- Drive line-up, max.	µF	230400	230400		
Power loss ¹⁾					
- At 50 Hz 400 V	kW	12.1	13.3		
- At 60 Hz 460 V	kW	13	14.2		
Cooling air requirement	m^3/s	1.08	1.08		
Sound pressure level ²⁾					
L_{pA} (1 m) at 50/60 Hz	dB(A)	71 / 73	71 / 73		
Line/load connection		Flat connector for screw			
		M12	M12		
Max. connection cross-sections					
- Line connection (U1, V1, W1)	mm ²	6 x 240	6 x 240		
- DC-link connection (DCP, DCN)	mm ²	Busbar	Busbar		
- PE connection PE1	mm ²	1 x 240	1 x 240		
- PE connection PE2	mm ²	3 x 240	3 x 240		
Max. cable length (total of all motor cables and DC link)					
- Shielded	m	3900	3900		
- Unshielded	m	5850	5850		
Degree of protection		IP00	IP00		

4.4 Active Line Modules

Article number	6SL3330-	7TE41-2AA3	7TE41-4AA3		
Dimensions					
- Width	mm	704	704		
- Height	mm	1480	1480		
- Depth	mm	550	550		
Frame size		JX	JX		
Weight	kg	450	450		
Recommended fuse ³⁾		3NE1448-2	3NE1448-2		
- Number per phase (connected in parallel)		2	2		
- Rated current		850	850		
- Frame size acc. to IEC 60269		3	3		
Minimum short-circuit current ⁴⁾	A	21000	21000		

- 1) The specified power loss is the maximum value at 100% capacity utilization. The value in normal operation is lower.
- 2) Total sound pressure level of Active Interface Module and Active Line Module.
- 3) To achieve a UL-approved system, it is absolutely essential to use the fuse types specified in the table.
- 4) Minimum current required for reliable triggering of the protective devices.

Table 4- 43 Technical data for Active Line Modules, 3 AC 500 V ... 690 V

Article number	6SL3330-	7TG35-8AA3	7TG37-4AA3	7TG41-0AA3	7TG41-3AA3
Rated power					
- For I_{n_DC} (50 Hz, 690 V)	kW	630	800	1100	1400
- For I_{H_DC} (50 Hz, 690 V)	kW	620	705	980	1215
- For I_{n_DC} (50 Hz, 500 V)	kW	447	560	780	965
- For I_{H_DC} (50 Hz, 500 V)	kW	450	510	710	880
- For I_{n_DC} (60 Hz, 575 V)	HP	675	900	1250	1500
- For I_{H_DC} (60 Hz, 575 V)	HP	506	600	1000	1250
DC-link current					
- Rated current I_{n_DC}	A	644	823	1148	1422
- Base load current I_{H_DC}	A	573	732	1022	1266
- Maximum current I_{max_DC}	A	966	1234	1722	2133
Infeed/regenerative feedback current					
- Rated current I_{n_E}	A	575	735	1025	1270
- Maximum current I_{max_E}	A	862	1102	1537	1905
Supply voltages		3AC 500 -10% (-15% < 1 min) ... 3AC 690 +10%			
- Line voltage	V_{ACrms}	47 ... 63Hz			
- Line frequency	Hz	24 (20.4 ... 28.8)			
- Electronic power supply	V_{DC}	1.5 x U_{line}			
- DC-link voltage	V_{DC}				
Pulse frequency	kHz	2.5	2.5	2.5	2.5
Current consumption					
- Electronics current consumption (24 V DC)	A	1.4	1.5	1.7	1.7
- 500 V AC	A	3.0	4.4	4.4	4.4
- 690 V AC	A	2.1	3.1	3.1	3.1
Max. ambient temperature					
- Without derating	°C	40	40	40	40
- With derating	°C	55	55	55	55
DC link capacitance					
- Active Line Module	µF	7400	11100	14400	19200
- Drive line-up, max.	µF	59200	153600	153600	153600
Power loss ¹⁾					
- At 50 Hz 690 V	kW	6.8	10.2	13.6	16.5
- At 60 Hz 575 V	kW	6.2	9.6	12.9	15.3
Cooling air requirement	m ³ /s	0.78	1.08	1.08	1.08
Sound pressure level ²⁾					
L_{pA} (1 m) at 50/60 Hz	dB(A)	70 / 73	71 / 73	71 / 73	71 / 73
Line/load connection		Flat connector for screw			
		M12	M12	M12	M12
Max. connection cross-sections					
- Line connection (U1, V1, W1)	mm ²	4 x 240	6 x 240	6 x 240	6 x 240
- DC-link connection (DCP, DCN)	mm ²	Busbar	Busbar	Busbar	Busbar
- PE connection PE1	mm ²	1 x 240	1 x 240	1 x 240	1 x 240
- PE connection PE2	mm ²	2 x 240	3 x 240	3 x 240	3 x 240
Max. cable length (total of all motor cables and DC link)					
- Shielded	m	2250	2250	2250	2250
- Unshielded	m	3375	3375	3375	3375
Degree of protection		IP00	IP00	IP00	IP00

4.4 Active Line Modules

Article number	6SL3330-	7TG35-8AA3	7TG37-4AA3	7TG41-0AA3	7TG41-3AA3
Dimensions					
- Width	mm	503	704	704	704
- Height	mm	1475	1480	1480	1480
- Depth	mm	540	550	550	550
Frame size		HX	JX	JX	JX
Weight	kg	290	450	450	450
Recommended fuse ³⁾		3NE1447-2	3NE1448-2	3NE1436-2	3NE1438-2
- Number per phase (connected in parallel)		1	1	2	2
- Rated current		670	850	630	800
- Frame size acc. to IEC 60269		3	3	3	3
Minimum short-circuit current ⁴⁾	A	8400	10500	16000	20000

- 1) The specified power loss is the maximum value at 100% capacity utilization. The value in normal operation is lower.
- 2) Total sound pressure level of Active Interface Module and Active Line Module.
- 3) To achieve a UL-approved system, it is absolutely essential to use the fuse types specified in the table.
- 4) Minimum current required for reliable triggering of the protective devices.

Overload capability

The Active Line Modules have an overload reserve.

The criterion for overload is that the Active Line Module is operated with its base load current before and after the overload occurs (a load duration of 300 s is used as a basis here).

High overload

The base load current for a high overload I_{H_DC} is based on a duty cycle of 150% for 60 s; the max. current I_{max_DC} can flow for 5 s.

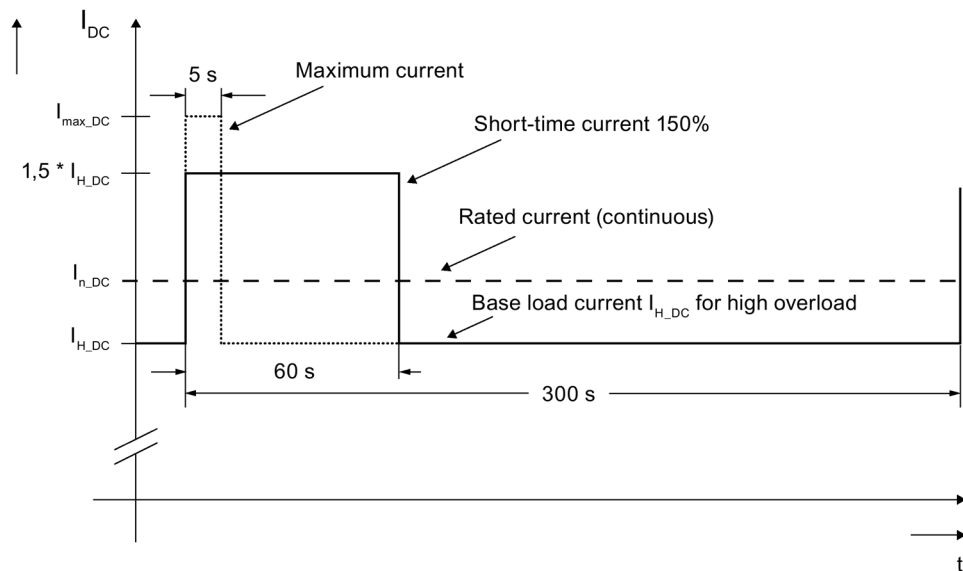

Figure 4-39 High overload

Motor Modules

5.1 Description

A Motor Module is a power unit (DC-AC inverter) that provides the power supply for the motor connected to it. Power is supplied by means of the DC link of the drive unit.
 A Motor Module must be connected to a Control Unit via DRIVE-CLiQ. The open-loop and closed-loop control functions are stored in the Control Unit.

Table 5- 1 Overview of Motor Modules

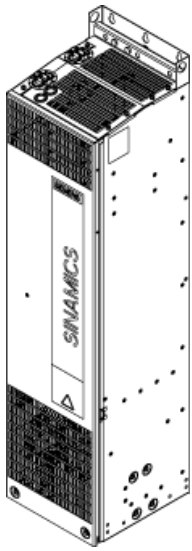
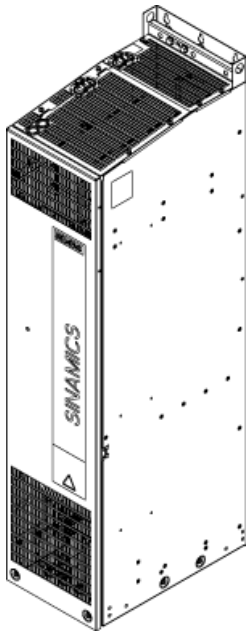
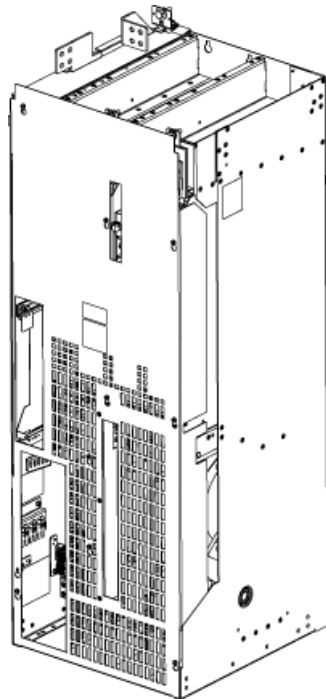
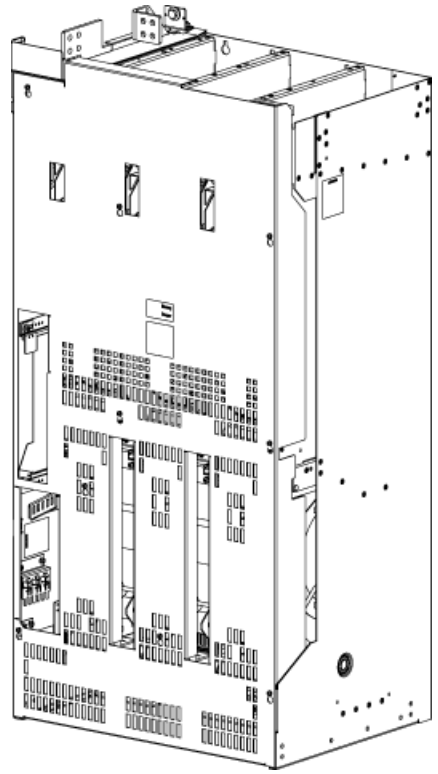
			
Frame size FX	Frame size GX	Frame size HX	Frame size JX

Operating principle

Motor Modules are designed for multi-axis drive systems and are controlled by either a CU320-2 or a SIMOTION D Control Unit. Motor Modules are interconnected by means of a shared DC busbar.

One or more Motor Modules are supplied with energy for the motors via the DC link. Both synchronous and induction motors can be operated.

Since the Motor Modules share the same DC link, they can exchange energy with one another, i.e. if one Motor Module operating in generator mode produces energy, the energy can be used by another Motor Module operating in motor mode. The DC link is supplied with line voltage by a Line Module.

Characteristics of the Motor Modules

- Version for 510 ... 720 V DC (line voltage 3 AC 380 ... 480 V) from 210 to 1405 A
Version for 675 ... 1035 V DC (line voltage 3 AC 500 ... 690 V) from 85 to 1270 A
- Internal air cooling
- Short-circuit/ground-fault-proof
- Electronic rating plate
- Operating status and error status via LEDs
- DRIVE-CLiQ interface for communication with the Control Unit and/or other components in the drive line-up
- Integration in system diagnostics

5.2 Safety information



WARNING

Not observing fundamental safety instructions and residual risks

Not observing fundamental safety instructions and residual risks listed in Chapter 1 can result in accidents with severe injuries or death.

- Comply with the fundamental safety instructions.
- When assessing the risk, take into account remaining risks.

WARNING

High leakage currents when the protective conductor in the line feeder cable is interrupted

The drive components conduct a high leakage current via the protective conductor. Touching conductive parts when the protective conductor is interrupted can result in death or serious injury.

- Ensure that the external protective conductor satisfies at least one of the following conditions:
 - It has been installed so that it is protected against mechanical damage. ¹⁾
 - For an individual core, it has a cross-section of at least 10 mm² Cu.
 - If it is a conductor of a multi-conductor cable, it has a cross-section of at least 2.5 mm² Cu.
 - It has a second protective conductor in parallel with the same cross-section.
 - It complies with the local regulations for equipment with increased leakage current.
- ¹⁾ Cables laid within control cabinets or closed machine housings are considered to be adequately protected from mechanical damage.

WARNING

Fire due to inadequate ventilation clearances

Inadequate ventilation clearances can cause overheating with a risk for personnel through smoke development and fire. This can also result in more downtimes and reduced service lives of Line Modules.

- Observe the ventilation clearances above, below, and in front of the Motor Modules, which are specified in the dimension drawings.

CAUTION

Fire due to overheating when the total length of the power cables is exceeded

Overheating and a fire can result when the total length of the power cables is exceeded.

- Ensure that the total length of the power cables (motor feeder cables and DC link cables) does not exceed the values specified in the technical data.

NOTICE

Material damage caused by the failure to remove linkage levers for devices of frame sizes HX and JX

The failure to remove linkage levers from devices of frame sizes HX and JX can cause damage to the device as a result of undershooting the necessary voltage clearances.

- For devices of frame sizes HX and JX, remove the linkage levers marked in red once the devices have been installed.

NOTICE

Material damage caused by loose power connections

Insufficient tightening torques or vibration can result in faulty electrical connections. This can cause fire damage or malfunctions.

- Tighten all power connections with the specified tightening torques, e.g. line supply connection, motor connection, DC link connections.
- Check the tightening torques of all power connections at regular intervals and tighten them when required. This applies in particular after transport.

NOTICE

Damage to the devices when performing a voltage test as a result of connections that are not disconnected

As part of routine tests, SINAMICS S components undergo a voltage test according to EN 61800-5-1. Connected devices can be damaged.

- Disconnect or unplug all SINAMICS devices before the voltage test of the machine equipment according to EN 60204-1, Section 18.4.

NOTICE

Damage through use of incorrect DRIVE-CLiQ cables

Damage or malfunctions can occur on the devices or system when DRIVE-CLiQ cables are used that are either incorrect or have not been released for this purpose.

- Only use suitable DRIVE-CLiQ cables that have been released by Siemens for the particular application.

5.3 Interface description

5.3.1 Overview

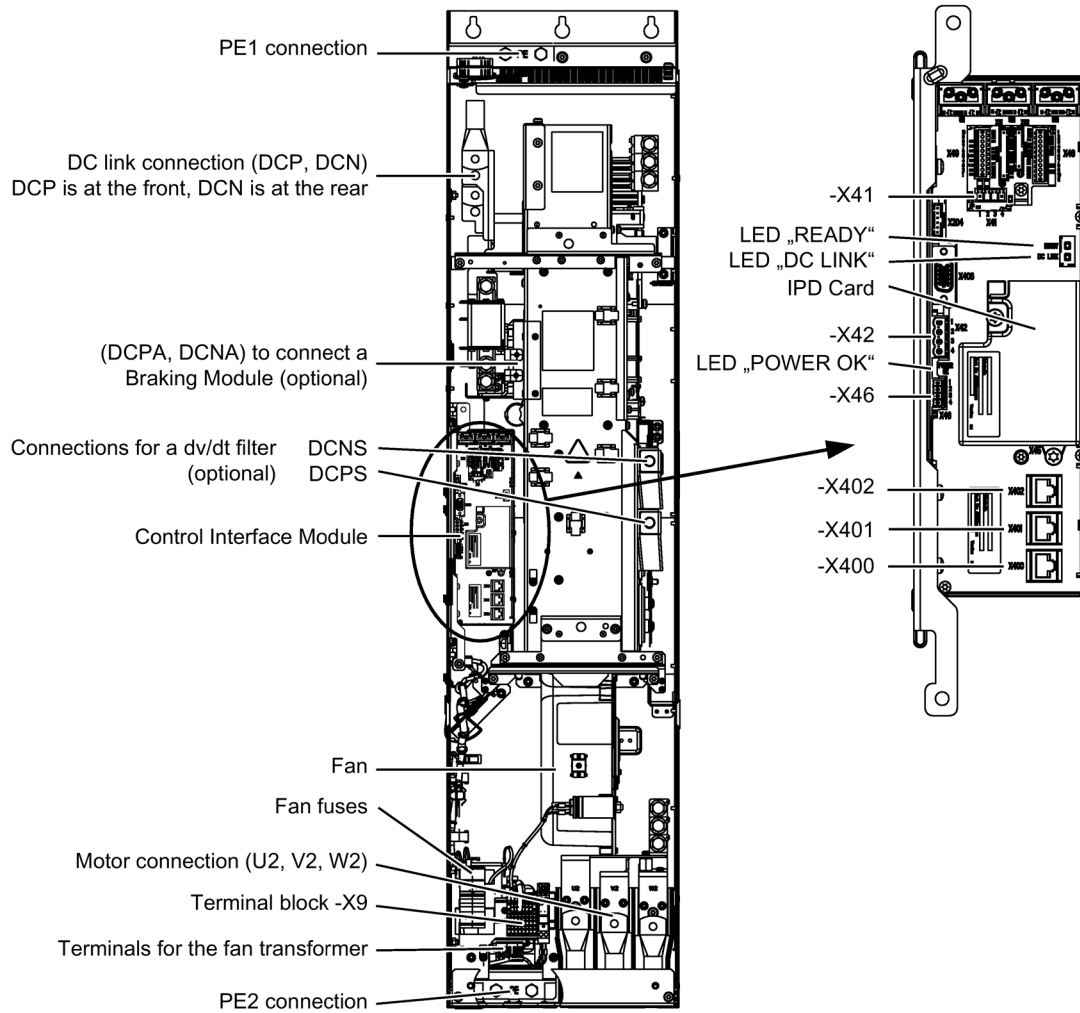

Figure 5-1 Motor Module, frame size FX

5.3 Interface description

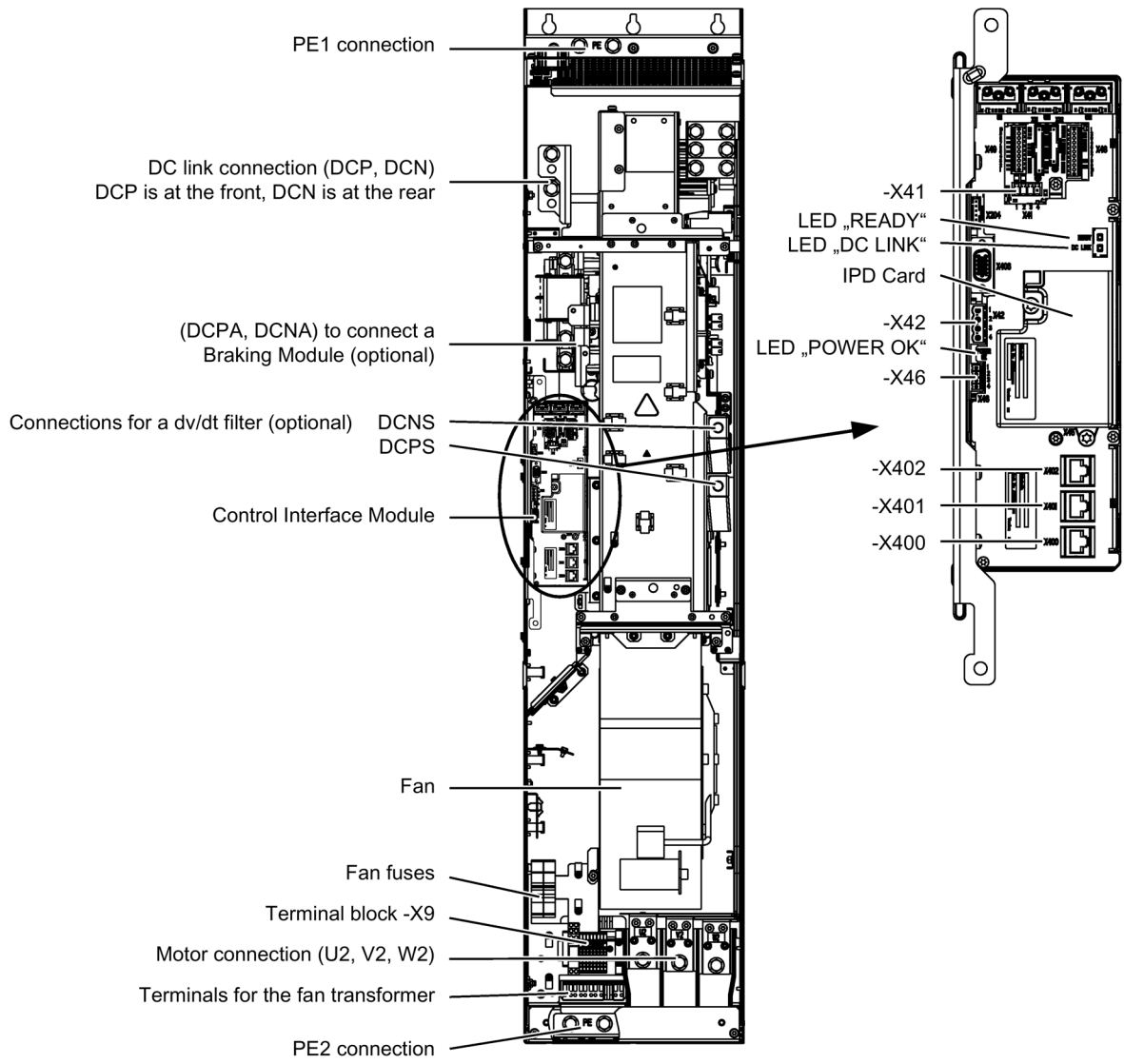

Figure 5-2 Motor Module, frame size GX

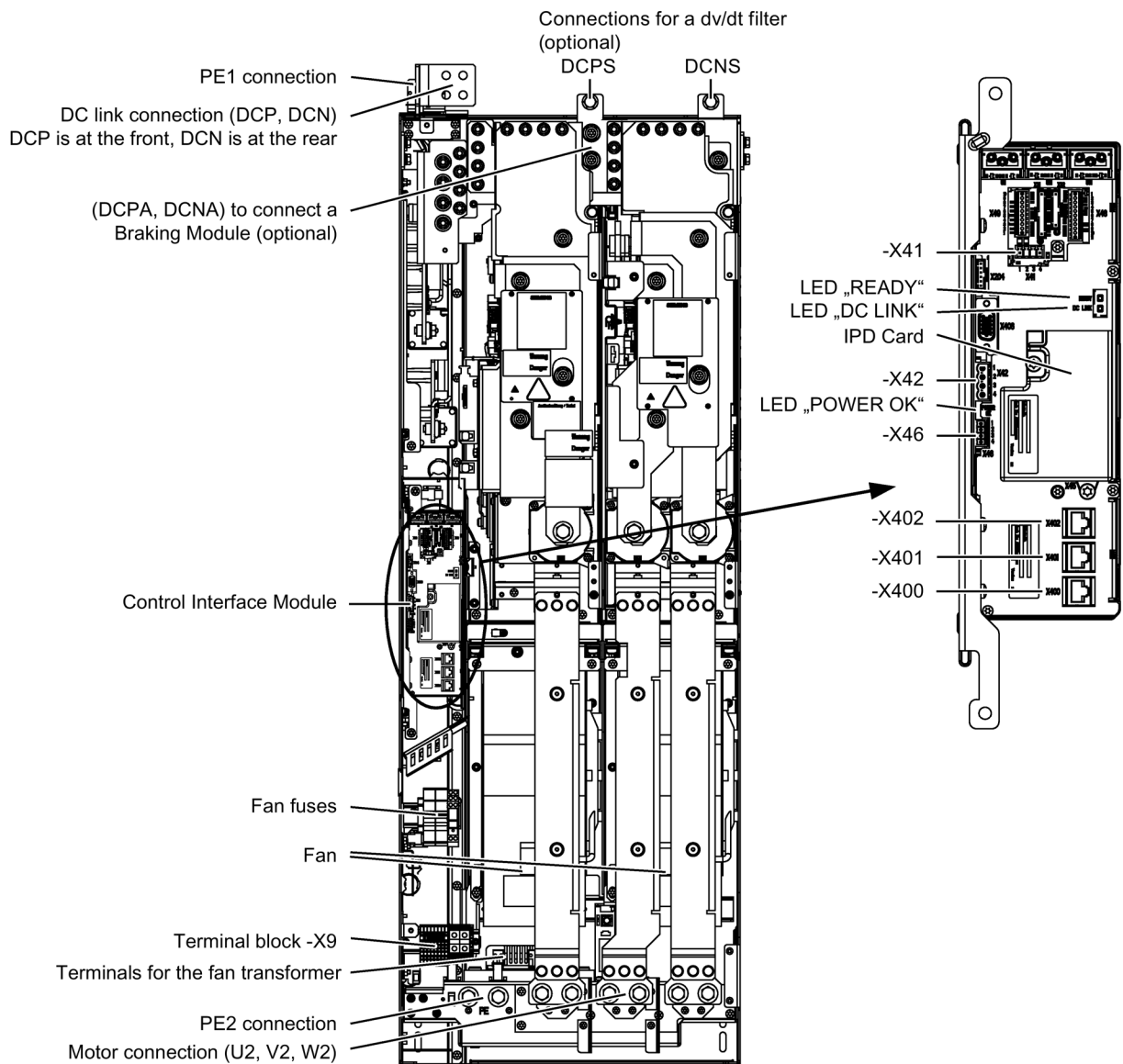

Figure 5-3 Motor Module, frame size HX

5.3 Interface description

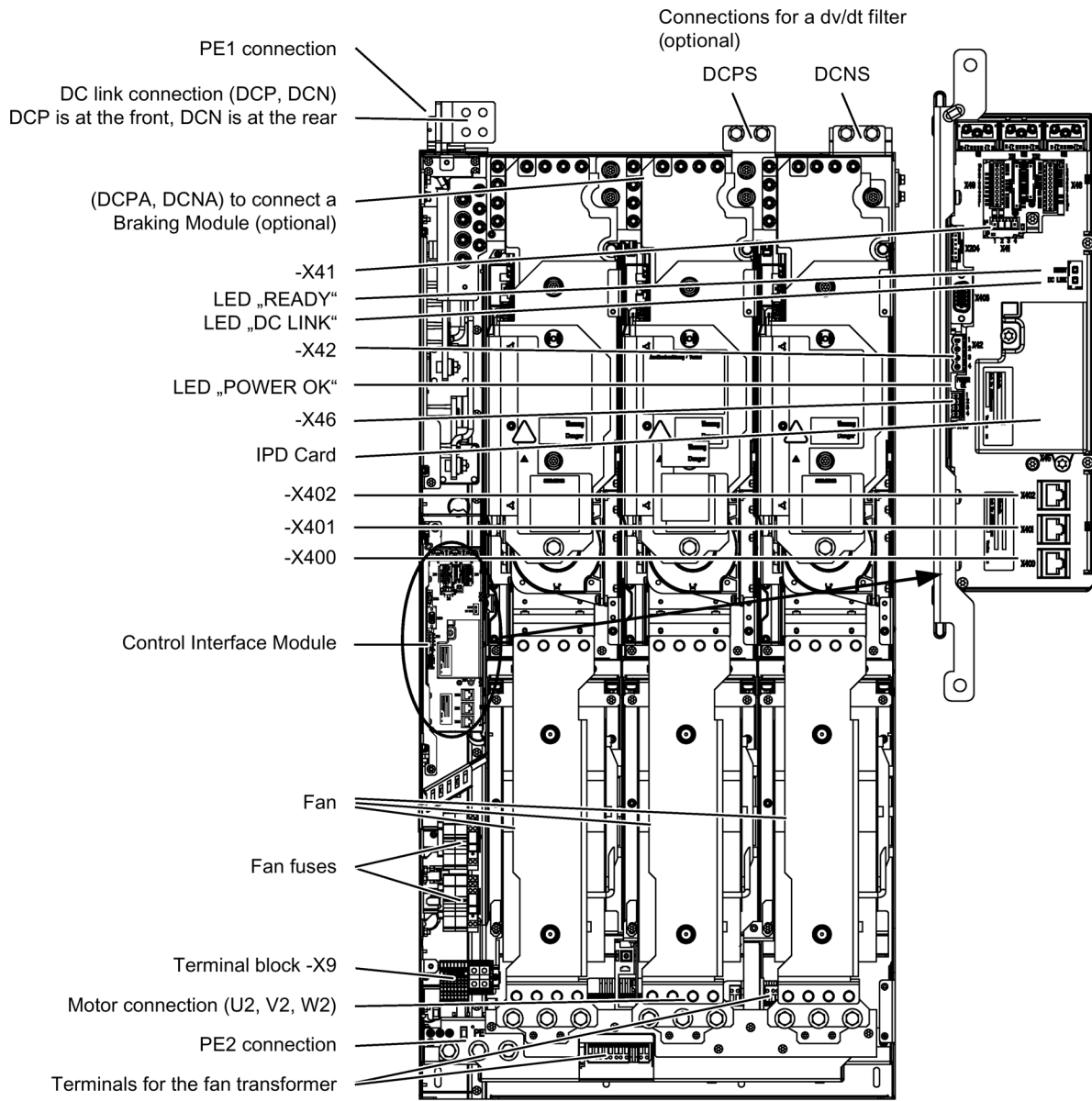

Figure 5-4 Motor Module, frame size JX

5.3.2 Connection example

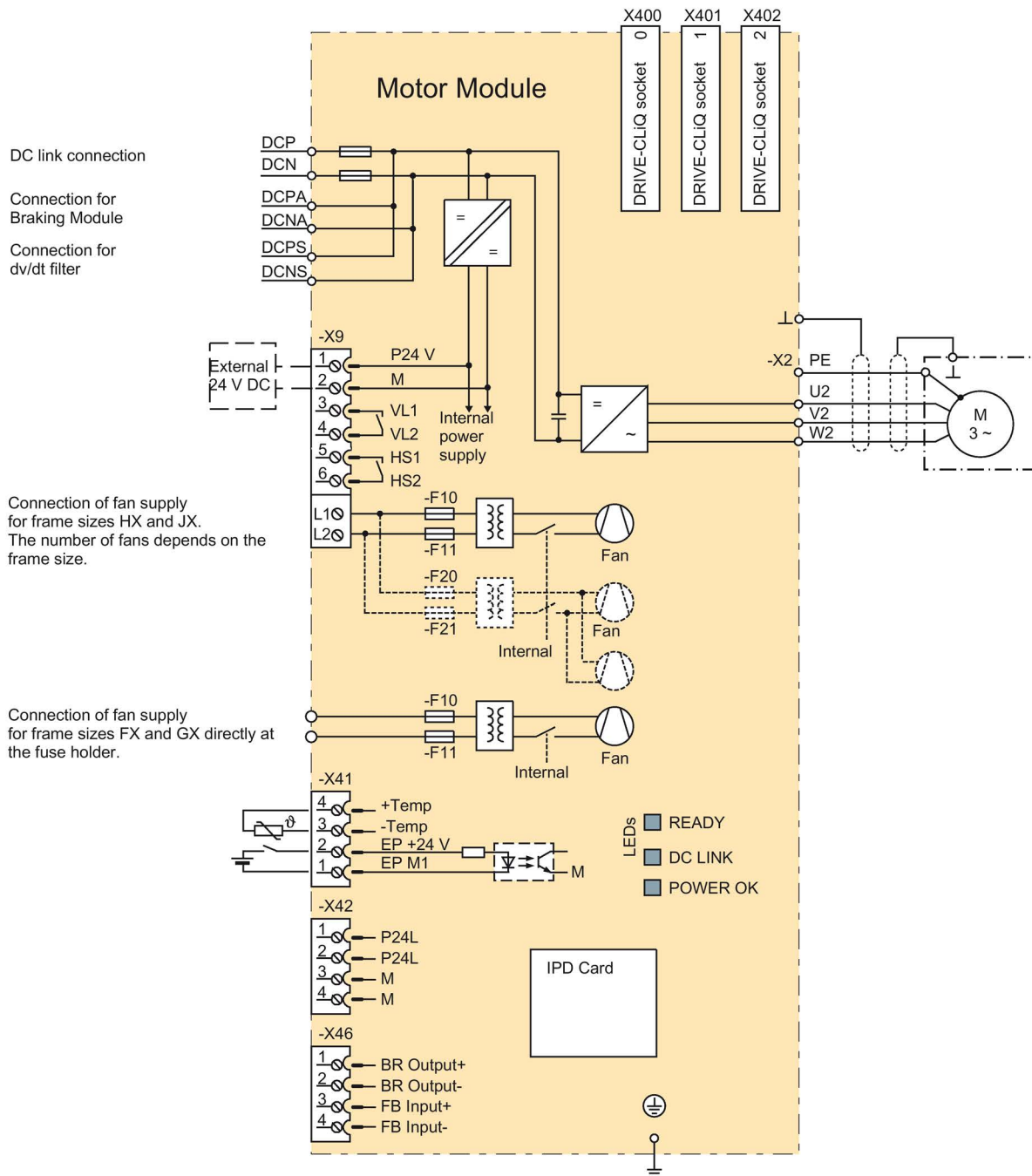

Figure 5-5 Connection example Motor Modules

5.3.3 DC link/motor connection

Table 5- 2 DC link/motor connection of the Motor Module

Terminals	Technical specifications
DCP, DCN DC power input	<p>Voltage:</p> <ul style="list-style-type: none"> • 510 ... 720 V DC • 675 ... 1035 V DC <p>Connections:</p> <ul style="list-style-type: none"> • Frame sizes FX / GX: Thread M10 / 25 Nm for cable lugs in accordance with DIN 46234 / DIN 46235 ¹⁾ • Frame sizes HX / JX: d = 12 mm (M10 / 25 Nm) flat connector for busbar connection
D CPA, DCNA Connection for Braking Module	<p>Voltage:</p> <ul style="list-style-type: none"> • 510 ... 720 V DC • 675 ... 1035 V DC <p>Connections:</p> <ul style="list-style-type: none"> • Frame sizes FX / GX: Threaded bolts M6 / 6 Nm for cable lugs in accordance with DIN 46234 / DIN 46235 ¹⁾ • Frame sizes HX / JX: Connection for connection clip
DCPS, DCNS Connection for a dV/dt filter plus VPL	<p>Voltage:</p> <ul style="list-style-type: none"> • 510 ... 720 V DC • 675 ... 1035 V DC <p>Connections:</p> <ul style="list-style-type: none"> • Frame sizes FX / GX: Thread M8 / 13 Nm for cable lugs in accordance with DIN 46234 / DIN 46235 ¹⁾ • Frame sizes HX / JX: Thread M10 / 25 Nm for cable lugs in accordance with DIN 46234 / DIN 46235 ¹⁾
U2, V2, W2 3 AC power output	<p>Voltage:</p> <ul style="list-style-type: none"> • 0 V 3 AC to 0.72 x DC link voltage <p>Connecting thread:</p> <ul style="list-style-type: none"> • Frame sizes FX / GX: M10 / 25 Nm for cable lugs in accordance with DIN 46234 / DIN 46235 ¹⁾ • Frame sizes HX / JX: M12 / 50 Nm for cable lugs in accordance with DIN 46234 / DIN 46235 ¹⁾
PE connection PE1, PE2	<p>Connecting thread:</p> <ul style="list-style-type: none"> • Frame sizes FX / GX: M10 / 25 Nm for cable lugs in accordance with DIN 46234 / DIN 46235 ¹⁾ • Frame sizes HX / JX: M12 / 50 Nm for cable lugs in accordance with DIN 46234 / DIN 46235 ¹⁾

1) Dimensions for connecting alternative cable lugs, see "cable lugs" in the appendix.

5.3.4 X9 terminal strip

Table 5- 3 Terminal strip X9

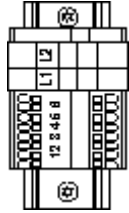
	Terminal	Signal name	Technical specifications
	1	P24V	External 24 V DC supply Voltage: 24 V DC (20.4 ... 28.8 V) Current consumption: max. 1.4 A
	2	M	
	3	VL1	240 V AC: 8 A max. 24 V DC: max. 1 A isolated
	4	VL2	
	5	HS1	240 V AC: 8 A max. 24 V DC: max. 1 A isolated
	6	HS2	
	L1	Connection for fan supply (frame sizes HX and JX only)	380 ... 480 V AC / 500 ... 690 V AC Current consumption: See Technical data
	L2		
Max. connectable cross-section: - terminal 1 ... 6: 2.5 mm ² - terminals L1, L2: 35 mm ²			

Note

Connecting the fan supply with frame sizes FX and GX

The fan supply for frame sizes FX and GX is connected directly to fuse holders -F10 and -F11.

5.3.5 DCPS, DCNS connection for a dV/dt filter

Table 5- 4 DCPS, DCNS

Frame size	Connectable cross-section	Terminal screw
FX	1 x 35 mm ²	M8
GX	1 x 70 mm ²	M8
HX	1 x 185 mm ²	M10
JX	2 x 185 mm ²	M10

With frame sizes FX and GX, the connecting cables are routed down through the Motor Module and out.

5.3.6 X41 EP terminal / temperature sensor connection

Table 5- 5 Terminal strip X41

	Terminal	Function	Technical specifications
	1	EP M1 (Enable Pulses)	Supply voltage: 24 V DC (20.4 ... 28.8 V) Current consumption: 10 mA The pulse inhibit function is only available when Safety Integrated Basic Functions are enabled.
	2	EP +24 V (Enable Pulses)	
	3	-Temp	Temperature sensor connection: KTY84-1C130 / PT100 / PT1000 / PTC
	4	+Temp	
Max. connectable cross-section: 1.5 mm ²			



! WARNING

Electric shock in the event of voltage flashovers at the temperature sensor

Voltage flashovers in the signal electronics can occur in motors without safe electrical separation of the temperature sensors.

- Only use temperature sensors that fully comply with the specifications of the safety isolation.
- If safe electrical separation cannot be guaranteed (for linear motors or third-party motors, for example), use a Sensor Module External (SME120 or SME125) or Terminal Module TM120.

NOTICE

Device failure as a result of unshielded or incorrectly routed cables to temperature sensors

Unshielded or incorrectly routed cables to temperature sensors can result in interference being coupled into the signal processing electronics from the power side. This can result in significant disturbance of all signals (fault messages) up to failure of individual components (destruction of the devices).

- Only use shielded cables as temperature sensor cables.
- If temperature sensor cables are routed together with the motor cable, use separately shielded cables twisted in pairs.
- Connect the cable shield to ground potential through a large surface area.
- Recommendation: Use the appropriate MOTION-CONNECT cables.

NOTICE

Damage to motor in the event of incorrectly connected KTY temperature sensor

If a KTY temperature sensor is connected with incorrect polarity, it is not possible to detect when the motor overheats. Overheating can cause damage to the motor.

- Connect a KTY temperature sensor with the correct polarity.

Note

The temperature sensor connection can be used for motors that are equipped with a KTY84-1C130, PT100, PT1000 or PTC measuring sensor in the stator windings.

Note**Function of the EP terminals**

The function of the EP terminals is only available when Safety Integrated Basic Functions are enabled.

5.3.7 X42 terminal strip

Table 5- 6 Terminal strip X42 voltage supply for Control Unit, Sensor Module and Terminal Module

	Terminal	Function	Technical specifications
	1	P24L	Power supply for Control Unit, Sensor Module and Terminal Module (18 ... 28.8 V) Maximum load current: 3 A
	2		
	3	M	
	4		
Max. connectable cross-section: 2.5 mm ²			

Note**Connection options for terminal strip X42**

The terminal strip is not intended for free 24 V DC availability (for example for supplying further line-side components), as the voltage supply of the Control Interface Module could also be overloaded and operating capability could thus be compromised.

5.3.8 X46 Brake control and monitoring

Table 5- 7 Terminal strip X46 brake control and monitoring

	Terminal	Function	Technical specifications
	1	BR output +	Brake connection Supply voltage: 24 V DC Max. load current: 0.2 mA
	2	BR output -	
	3	FB input +	
	4	FB input -	
Max. connectable cross-section: 1.5 mm ²			

Note

The interface is intended for connection of the Safe Brake Adapter.

 WARNING
<p>Fire due to overheating when the total length of the connecting cables is exceeded</p> <p>Excessively long connection cables on terminal strip X46 can cause components to overheat with the associated risk of fire and smoke.</p> <ul style="list-style-type: none"> • Limit the length of the connecting cables to a maximum of 10 m. • Do not route the connection cable outside the control cabinet or control cabinet group.

5.3.9 DRIVE-CLiQ interfaces X400, X401, X402

Table 5- 8 DRIVE-CLiQ interfaces X400, X401, X402

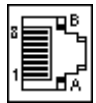
	PIN	Signal name	Technical specifications
	1	TXP	Transmit data +
	2	TXN	Transmit data -
	3	RXP	Receive data +
	4	Reserved, do not use	
	5	Reserved, do not use	
	6	RXN	Receive data -
	7	Reserved, do not use	
	8	Reserved, do not use	
	A	+ (24 V)	24 V power supply
	B	M (0 V)	Electronics ground
Blanking plate for DRIVE-CLiQ interfaces (50 pcs.) Article number: 6SL3066-4CA00-0AA0			

5.3.10 Meaning of the LEDs on the Control Interface Module in the Motor Module

Table 5- 9 Meaning of the LEDs "READY" and "DC LINK" on the Control Interface Module in the Motor Module

LED state		Description
READY	DC LINK	
Off	Off	The electronics power supply is missing or out of tolerance.
Green	--- ¹⁾	The component is ready for operation and cyclic DRIVE-CLiQ communication is taking place.
	Orange	The component is ready for operation and cyclic DRIVE-CLiQ communication is taking place. The DC-link voltage is present.
	Red	The component is ready for operation and cyclic DRIVE-CLiQ communication is taking place. The DC link voltage lies outside the permitted tolerance range.
Orange	Orange	DRIVE-CLiQ communication is being established.
Red	--- ¹⁾	This component has at least one fault. Remark: The LED is activated irrespective of whether the corresponding messages have been reconfigured.
Flashing light 0.5 Hz: green/red	--- ¹⁾	Firmware is being downloaded.
Flashing light 2 Hz: green/red	--- ¹⁾	Firmware download is complete. Waiting for POWER ON.
Flashing light 2 Hz: green/orange or red/orange	--- ¹⁾	Detection of the components via LED is activated (p0124). Note: Both options depend on the LED status when module recognition is activated via p0124 = 1.

¹⁾ Irrespective of the status of the LED "DC LINK"

Table 5- 10 Meaning of the LED "POWER OK" on the Control Interface Module in the Motor Module

LED	Color	Status	Description
POWER OK	Green	Off	DC link voltage or control voltage at -X9 too low.
		On	The component is ready for operation.
		Flashing light	There is a fault. If the LED continues to flash after you have performed a POWER ON, please contact your Siemens service center.



WARNING

Electric shock when live parts of the DC link are touched

Hazardous DC link voltages may be present at any time regardless of the status of the "DC LINK" LED. This means that when live parts are touched, this can result in death or serious injury.

- Observe the warning information on the component.

5.4 Dimension drawing

Dimension drawing, frame size FX

The mandatory cooling clearances are indicated by the dotted line.

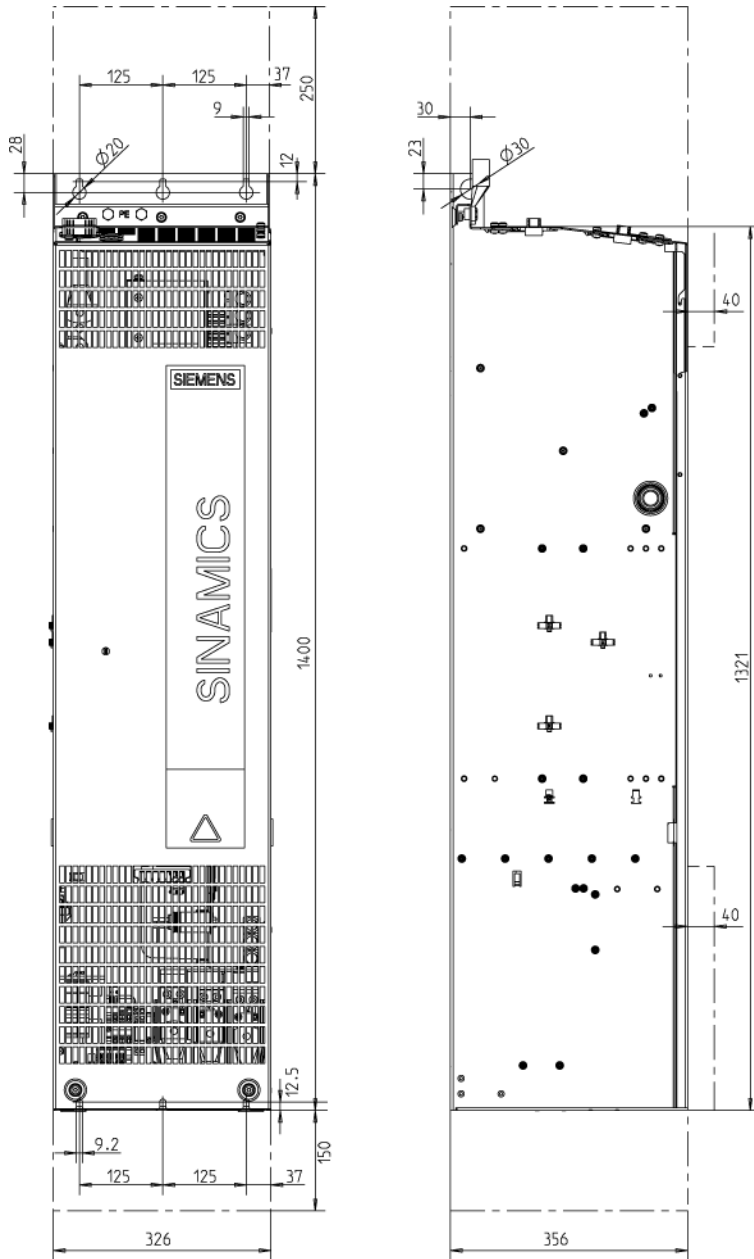

Figure 5-6 Dimension drawing Motor Module, frame size FX. Front view, side view

Dimension drawing, frame size GX

The mandatory cooling clearances are indicated by the dotted line.

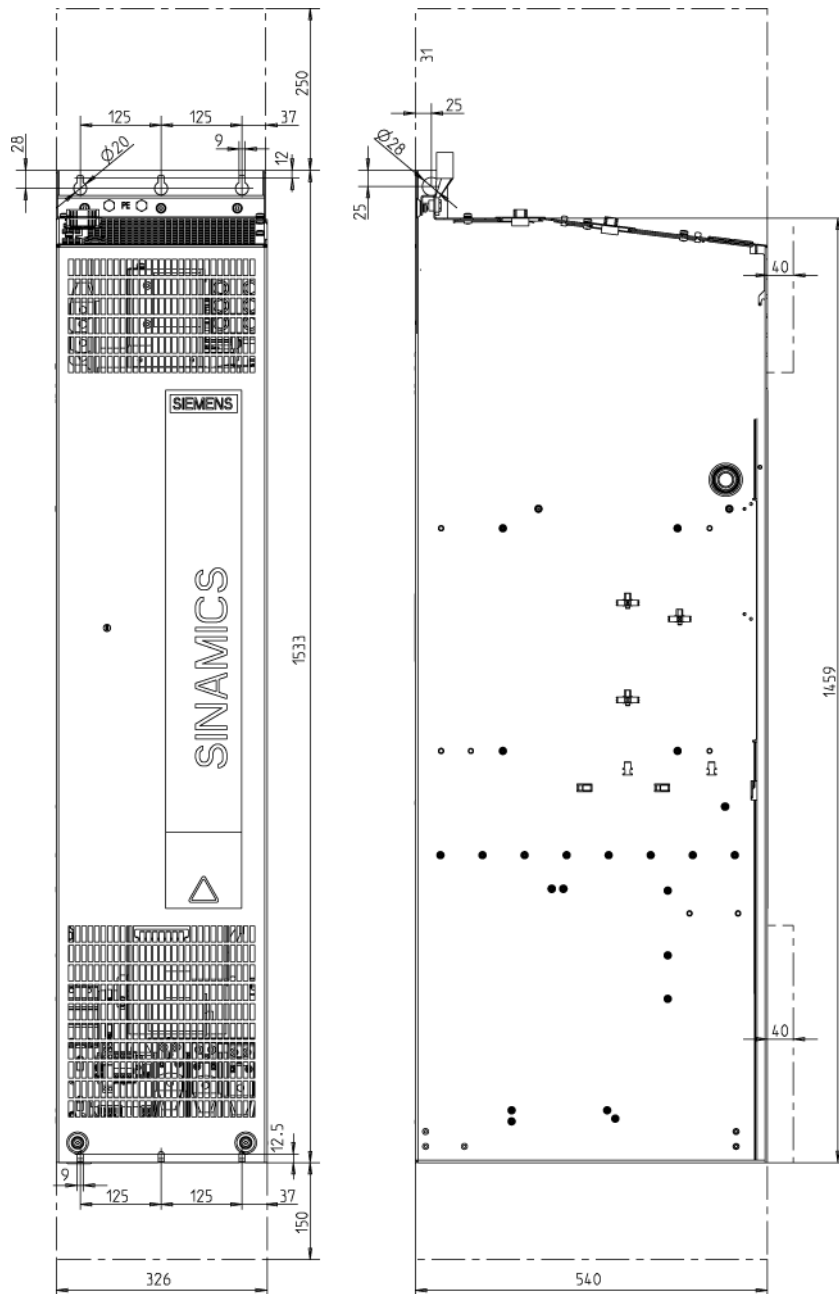

Figure 5-7 Dimension drawing Motor Module, frame size GX. Front view, side view

Dimension drawing, frame size HX

The mandatory cooling clearances are indicated by the dotted line.

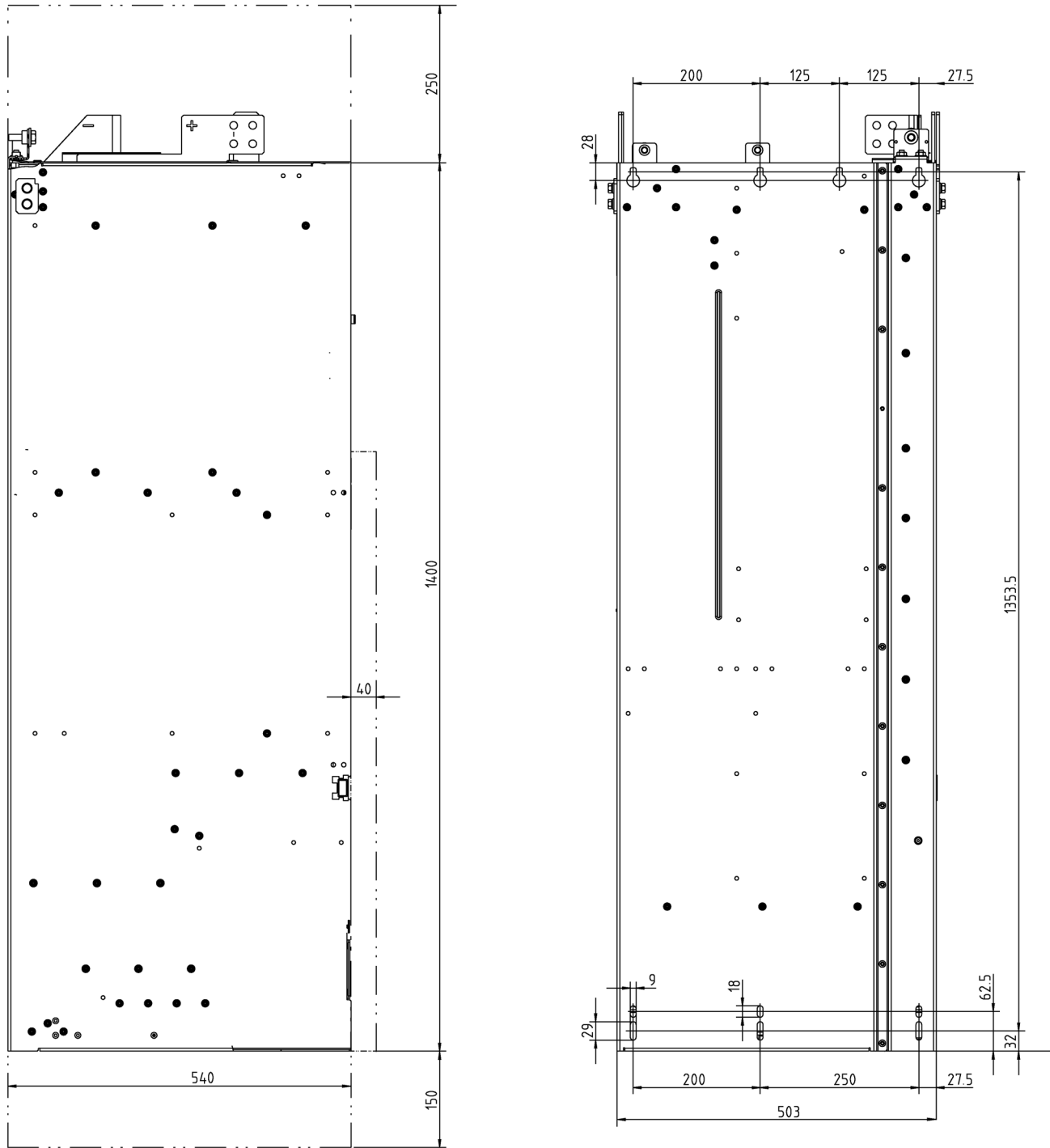

Figure 5-8 Dimension drawing Motor Module, frame size HX. Side view, rear view

Dimension drawing, frame size JX

The mandatory cooling clearances are indicated by the dotted line.

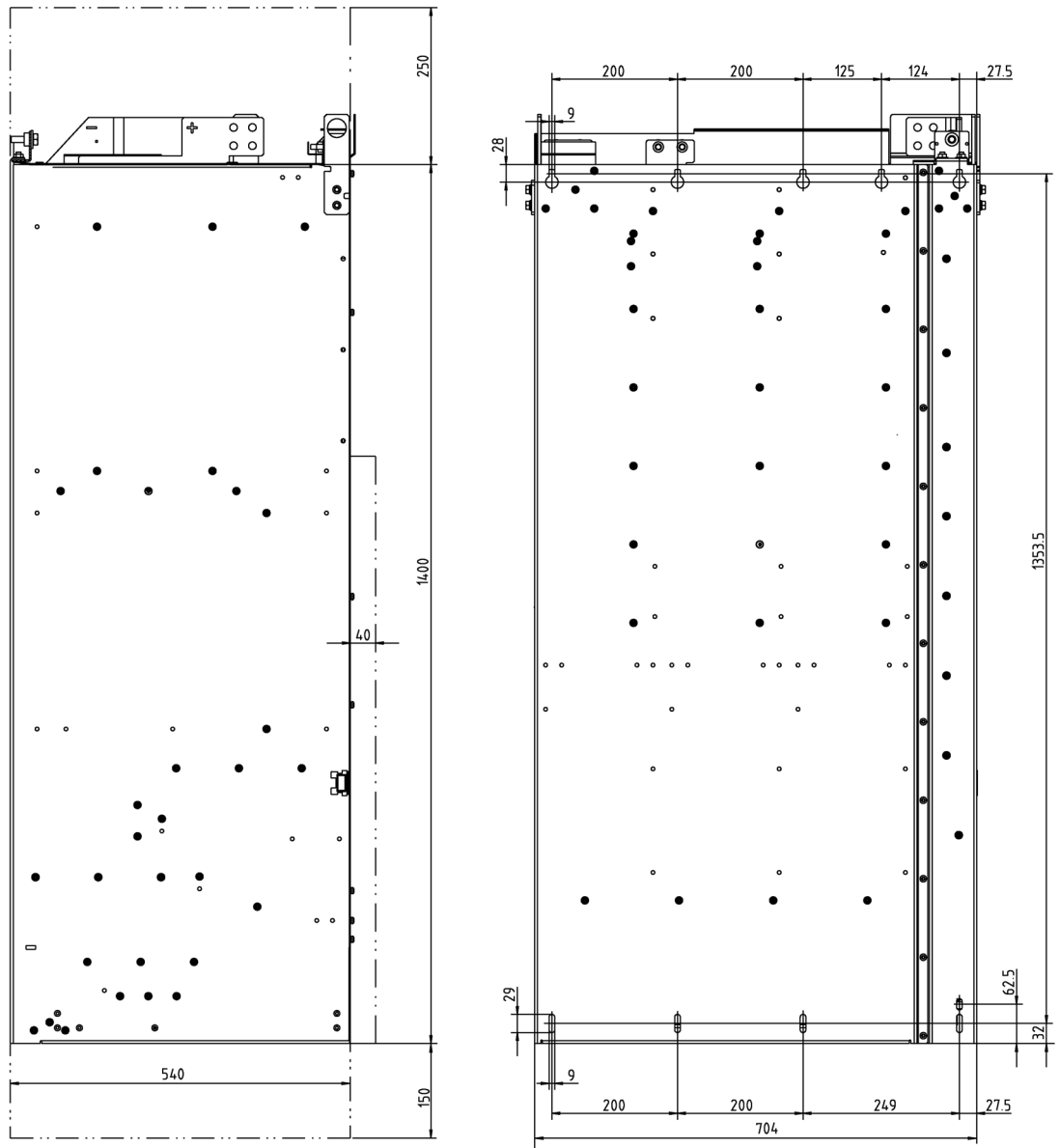

Figure 5-9 Dimension drawing Motor Module, frame size JX. Side view, rear view

5.5 Electrical connection

Adjusting the fan voltage (-T10)

The power supply for the device fans (1 AC 230 V) in the Motor Module (-T10) is taken from the line supply using transformers. The installation position of the transformers is indicated in the interface descriptions.

The transformers are fitted with primary taps so that they can be fine-tuned to the line supply voltage.

If necessary, the connection fitted in the factory, shown with a dashed line, must be reconnected to the actual line voltage.

Note

Two transformers (T10 and -T20) are installed in Motor Modules frame size JX. The two primary-side terminals on each of these devices must be adjusted together.

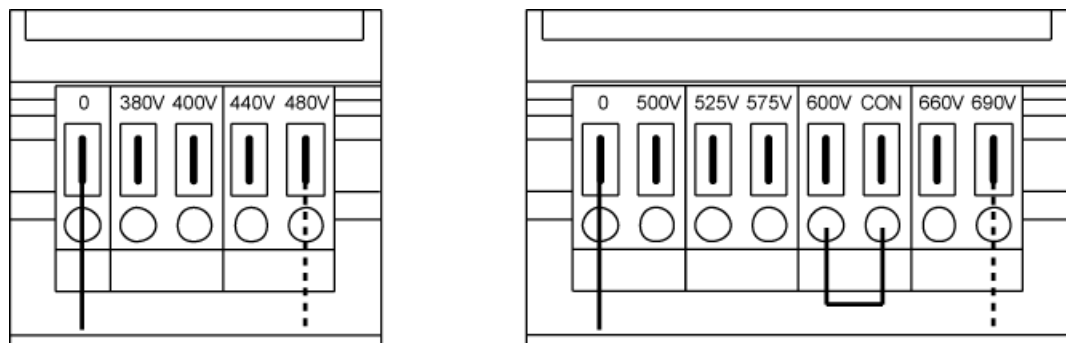

Figure 5-10 Setting terminals for the fan transformers (3 AC 380 to 480 V / 3 AC 500 to 690 V)

The supply voltage assignments for making the appropriate setting on the fan transformer are indicated in the following tables (factory presetting: 480 V / 0 V or 690 V / 0 V).

Note

With the 3 AC 500 V to 690 V fan transformer, a jumper is inserted between the "600 V" terminal and "CON" terminal. The jumper between terminal "600 V" and "CON" is for internal use.

WARNING

Fire due to overheating resulting from insufficient equipment fan voltage

If the terminals are not reconnected to the actual line voltage, overheating and human danger due to smoke and fire may result.

This can also cause the fan fuses to blow due to overload.

- Set the terminals in accordance with the actual line voltage.

Table 5- 11 Line voltage assignment for the setting at the fan transformer (3 AC 380 ... 480 V)

Line voltage	Tap at the fan transformer (-T10)
380 V \pm 10%	380 V
400 V \pm 10%	400 V
440 V \pm 10%	440 V
480 V \pm 10%	480 V

Table 5- 12 Line voltage assignment for the setting at the fan transformer (3 AC 500 ... 690 V)

Line voltage	Tap at the fan transformer (-T10)
500 V \pm 10%	500 V
525 V \pm 10%	525 V
575 V \pm 10%	575 V
600 V \pm 10%	600 V
660 V \pm 10%	660 V
690 V \pm 10%	690 V

5.6 Technical specifications

5.6.1 Motor Modules, 510 ... 720 V DC (line voltage 3 AC 380 ... 480 V)

Table 5- 13 Technical data for Motor Modules, 510 ... 720 V DC (line voltage 380 ... 480 V3 AC), Part 1

Article number	6SL3320-	1TE32-1AA3	1TE32-6AA3	1TE33-1AA3	1TE33-8AA3
Output current					
- Rated current I _{N A}	A	210	260	310	380
- Base load current I _L	A	205	250	302	370
- Base load current I _H	A	178	233	277	340
- For S6 operation (40%) I _{S6}	A	230	285	340	430
- Max. output current I _{max}	A	307	375	453	555
Type rating					
- Based on I _L (50 Hz 400 V) ¹⁾	kW	110	132	160	200
- Based on I _H (50 Hz 400 V) ¹⁾	kW	90	110	132	160
- Based on I _L (60 Hz 460 V) ²⁾	HP	150	200	250	300
- Based on I _H (60 Hz 460 V) ²⁾	HP	150	200	200	250
DC-link current					
Rated current I _{N DC} when fed via					
- Basic/Smart Line Module	A	252	312	372	456
- Active Line Module	A	227	281	335	411
Base load current I _{L DC} when fed via					
- Basic/Smart Line Module	A	245	304	362	444
- Active Line Module	A	221	273	326	400
Base load current I _{H DC} when fed via					
- Basic/Smart Line Module	A	224	277	331	405
- Active Line Module	A	202	250	298	365
Supply voltages		510 ... 720			
- DC-link voltage	V _{DC}	24 (20.4 ... 28.8)			
- Electronic power supply	V _{DC}	0 ... 0.72 x DC-link voltage			
- Output voltage	V _{ACrms}	0 ... 0.72 x DC-link voltage			
Rated pulse frequency	kHz	2	2	2	2
- Max. pulse frequency without derating	kHz	2	2	2	2
- Max. pulse frequency with derating	kHz	8	8	8	8
Max. ambient temperature					
- Without derating	°C	40	40	40	40
- With derating	°C	55	55	55	55
DC-link capacitance	µF	4200	5200	6300	7800
Current consumption					
- Electronics current consumption (24 V DC)	A	0.8	0.8	0.9	0.9
- Fan supply, at 2 AC 400 V, 50/60 Hz	A	0.63 / 0.95	1.13 / 1.7	1.8 / 2.7	1.8 / 2.7
Power loss, max.³⁾					
- at 50 Hz 400 V	kW	1.86	2.5	2.96	3.67
- at 60 Hz 460 V	kW	1.94	2.6	3.1	3.8
Cooling air requirement	m ³ /s	0.17	0.23	0.36	0.36
Sound pressure level					
L _{pA} (1 m) at 50/60 Hz	dB(A)	64 / 67	71 / 71	69 / 73	69 / 73

Article number	6SL3320-	1TE32-1AA3	1TE32-6AA3	1TE33-1AA3	1TE33-8AA3
Connections					
- DC-link connection		M10	M10	M10	M10
- Motor connection		M10	M10	M10	M10
- PE connection PE1		M10	M10	M10	M10
- PE connection PE2		M10	M10	M10	M10
Max. conductor cross-sections					
- DC-link connection (DCP, DCN)	mm ²	2 x 185	2 x 185	2 x 240	2 x 240
- Motor connection (U2, V2, W2)	mm ²	2 x 185	2 x 185	2 x 240	2 x 240
- PE connection PE1	mm ²	2 x 185	2 x 185	2 x 240	2 x 240
- PE connection PE2	mm ²	2 x 185	2 x 185	2 x 240	2 x 240
Max. motor cable length					
- Shielded	m	300	300	300	300
- Unshielded	m	450	450	450	450
Degree of protection		IP20	IP20	IP20	IP20
Dimensions					
- Width	mm	326	326	326	326
- Height	mm	1400	1400	1533	1533
- Depth	mm	356	356	545	545
Frame size		FX	FX	GX	GX
Weight	kg	95	95	136	136

- 1) Rated power of a typical 6-pole standard induction motor based on I_L or I_H at 3 AC 400 V 50 Hz.
- 2) Rated power of a typical 6-pole standard induction motor based on I_L or I_H at 3 AC 460 V 60 Hz.
- 3) The specified power loss is the maximum value at 100% capacity utilization. The value in normal operation is lower.

5.6 Technical specifications

Table 5- 14 Technical data for Motor Modules, 510 ... 720 V DC (line voltage 380 ... 480 V 3 AC), Part 2

Article number	6SL3320-	1TE35-0AA3	1TE36-1AA3	1TE37-5AA3	1TE38-4AA3
Output current					
- Rated current I_{NA}	A	490	605	745	840
- Base load current I_L	A	477	590	725	820
- Base load current I_H	A	438	460	570	700
- For S6 operation (40%) I_{S6}	A	540	--	--	--
- Max. output current I_{max}	A	715	885	1087	1230
Type rating					
- Based on I_L (50 Hz 400 V) ¹⁾	kW	250	315	400	450
- Based on I_H (50 Hz 400 V) ¹⁾	kW	200	250	315	400
- Based on I_L (60 Hz 460 V) ²⁾	HP	400	500	600	700
- Based on I_H (60 Hz 460 V) ²⁾	HP	350	350	450	600
DC-link current					
Rated current I_{NDC} when fed via					
- Basic/Smart Line Module	A	588	726	894	1008
- Active Line Module	A	529	653	805	907
Base load current I_{LDC} when fed via					
- Basic/Smart Line Module	A	573	707	871	982
- Active Line Module	A	515	636	784	884
Base load current I_{HDC} when fed via					
- Basic/Smart Line Module	A	523	646	795	897
- Active Line Module	A	470	581	716	807
Supply voltages		510 ... 720			
- DC-link voltage	V_{DC}	24 (20.4 ... 28.8)			
- Electronic power supply	V_{DC}	0 ... 0.72 x DC-link voltage			
- Output voltage	V_{ACrms}				
Rated pulse frequency					
- Max. pulse frequency without derating	kHz	2	1.25	1.25	1.25
- Max. pulse frequency with derating	kHz	2	1.25	1.25	1.25
	kHz	8	7.5	7.5	7.5
Max. ambient temperature					
- Without derating	°C	40	40	40	40
- With derating	°C	55	55	55	55
DC-link capacitance	µF	9600	12600	15600	16800
Current consumption					
- Electronics current consumption (24 V DC)	A	0.9	1.0	1.0	1.0
- Fan supply, at 2 AC 400 V, 50/60 Hz	A	1.8 / 2.7	3.6 / 5.4	3.6 / 5.4	3.6 / 5.4
Power loss, max. ³⁾					
- at 50 Hz 400 V	kW	4.28	5.84	6.68	7.15
- at 60 Hz 460 V	kW	4.5	6.3	7.3	7.8
Cooling air requirement	m³/s	0.36	0.78	0.78	0.78
Sound pressure level					
L_{pA} (1 m) at 50/60 Hz	dB(A)	69 / 73	70 / 73	70 / 73	70 / 73
Connections					
- DC-link connection		M10	4 x M10	4 x M10	4 x M10
- Motor connection		M10	2 x M12	2 x M12	2 x M12
- PE connection PE1		M10	M12	M12	M12
- PE connection PE2		M10	2 x M12	2 x M12	2 x M12

Article number	6SL3320-	1TE35-0AA3	1TE36-1AA3	1TE37-5AA3	1TE38-4AA3
Max. conductor cross-sections					
- DC-link connection (DCP, DCN)	mm ²	2 x 240	Busbar	Busbar	Busbar
- Motor connection (U2, V2, W2)	mm ²	2 x 240	4 x 240	4 x 240	4 x 240
- PE connection PE1	mm ²	2 x 240	1 x 240	1 x 240	1 x 240
- PE connection PE2	mm ²	2 x 240	2 x 240	2 x 240	2 x 240
Max. motor cable length					
- Shielded	m	300	300	300	300
- Unshielded	m	450	450	450	450
Degree of protection		IP20	IP00	IP00	IP00
Dimensions					
- Width	mm	326	503	503	503
- Height	mm	1533	1475	1475	1475
- Depth	mm	545	540	540	540
Frame size		GX	HX	HX	HX
Weight	kg	136	290	290	290

- 1) Rated power of a typical 6-pole standard induction motor based on I_L or I_H at 3 AC 400 V 50 Hz.
- 2) Rated power of a typical 6-pole standard induction motor based on I_L or I_H at 3 AC 460 V 60 Hz.
- 3) The specified power loss is the maximum value at 100% capacity utilization. The value in normal operation is lower.

5.6 Technical specifications

Table 5- 15 Technical data for Motor Modules, 510 ... 720 V DC (line voltage 380 ... 480 V3 AC), Part 3

Article number	6SL3320-	1TE41-0AA3	1TE41-2AA3	1TE41-4AA3	1TE41-4AS3
Output current					
- Rated current I_{NA}	A	985	1260	1405	1330
- Base load current I_L	A	960	1230	1370	1310
- Base load current I_H	A	860	1127	1257	1150
- For S6 operation (40%) I_{S6}	A	--	--	--	--
- Max. output current I_{max}	A	1440	1845	2055	2055
Type rating					
- Based on I_L (50 Hz 400 V) ¹⁾	kW	560	710	800	800
- Based on I_H (50 Hz 400 V) ¹⁾	kW	450	560	710	630
- Based on I_L (60 Hz 460 V) ²⁾	HP	800	1000	1150	1000
- Based on I_H (60 Hz 460 V) ²⁾	HP	700	900	1000	900
DC-link current					
Rated current I_{NDC} when fed via					
- Basic/Smart Line Module	A	1182	1512	1686	1550
- Active Line Module	A	1064	1361	1517	1403
Base load current I_{LDC} when fed via					
- Basic/Smart Line Module	A	1152	1474	1643	1525
- Active Line Module	A	1037	1326	1479	1405
Base load current I_{HDC} when fed via					
- Basic/Smart Line Module	A	1051	1345	1500	1676
- Active Line Module	A	946	1211	1350	1403
Supply voltages		510 ... 720			
- DC-link voltage	V_{DC}	24 (20.4 ... 28.8)			
- Electronic power supply	V_{DC}	0 ... 0.72 x DC-link voltage			
- Output voltage	V_{ACrms}				
Rated pulse frequency					
- Max. pulse frequency without derating	kHz	1.25	1.25	1.25	2
- Max. pulse frequency with derating	kHz	1.25	1.25	1.25	2
	kHz	7.5	7.5	7.5	4
Max. ambient temperature					
- Without derating	°C	40	40	40	40
- With derating	°C	55	55	55	55
DC-link capacitance	µF	18900	26100	28800	19200
Current consumption					
- Electronics current consumption (24 V DC)	A	1.25	1.4	1.4	1.4
- Fan supply, at 2 AC 400 V, 50/60 Hz	A	5.4 / 8.1	5.4 / 8.1	5.4 / 8.1	5.4 / 8.1
Power loss, max. ³⁾					
- at 50 Hz 400 V	kW	9.5	11.1	12.0	10.8
- at 60 Hz 460 V	kW	10.2	12.0	13.0	12.30
Cooling air requirement	m³/s	1.08	1.08	1.08	1.08
Sound pressure level					
L_{pA} (1 m) at 50/60 Hz	dB(A)	71 / 73	71 / 73	71 / 73	71 / 73
Connections					
- DC-link connection		4 x M10	4 x M10	4 x M10	4 x M10
- Motor connection		3 x M12	3 x M12	3 x M12	3 x M12
- PE connection PE1		M12	M12	M12	M12
- PE connection PE2		3 x M12	3 x M12	3 x M12	3 x M12

Article number	6SL3320-	1TE41-0AA3	1TE41-2AA3	1TE41-4AA3	1TE41-4AS3
Max. conductor cross-sections					
- DC-link connection (DCP, DCN)	mm ²	Busbar	Busbar	Busbar	Busbar
- Motor connection (U2, V2, W2)	mm ²	6 x 240	6 x 240	6 x 240	6 x 240
- PE connection PE1	mm ²	1 x 240	1 x 240	1 x 240	1 x 240
- PE connection PE2	mm ²	3 x 240	3 x 240	3 x 240	3 x 240
Max. motor cable length					
- Shielded	m	300	300	300	300
- Unshielded	m	450	450	450	450
Degree of protection		IP00	IP00	IP00	IP00
Dimensions					
- Width	mm	704	704	704	704
- Height	mm	1475	1475	1475	1475
- Depth	mm	540	540	540	540
Frame size		JX	JX	JX	JX
Weight	kg	450	450	450	450

- 1) Rated power of a typical 6-pole standard induction motor based on I_L or I_H at 3 AC 400 V 50 Hz.
- 2) Rated power of a typical 6-pole standard induction motor based on I_L or I_H at 3 AC 460 V 60 Hz.
- 3) The specified power loss is the maximum value at 100% capacity utilization. The value in normal operation is lower.

5.6.2 Motor Modules, 675 ... 1035 V DC (line voltage 3 AC 500 ... 690 V)

Table 5- 16 Technical data for Motor Modules, 675 ... 1035 V DC (line voltage 3 AC 500 ... 690 V), Part 1

Article number	6SL3320-	1TG28-5AA3	1TG31-0AA3	1TG31-2AA3	1TG31-5AA3
Output current					
- Rated current I_{NA}	A	85	100	120	150
- Base load current I_L	A	80	95	115	142
- Base load current I_H	A	76	89	107	134
- Max. output current I_{max}	A	120	142	172	213
Type rating					
- Based on I_L (50 Hz 690 V) ¹⁾	kW	75	90	110	132
- Based on I_H (50 Hz 690 V) ¹⁾	kW	55	75	90	110
- Based on I_L (50 Hz 500 V) ¹⁾	kW	55	55	75	90
- Based on I_H (50 Hz 500 V) ¹⁾	kW	45	55	75	90
- Based on I_L (60 Hz 575 V) ²⁾	HP	75	75	100	150
- Based on I_H (60 Hz 575 V) ²⁾	HP	75	75	100	125
DC-link current					
Rated current I_{NDC} when fed via					
- Basic/Smart Line Module	A	102	120	144	180
- Active Line Module	A	92	108	130	162
Base load current I_{LDC} when fed via					
- Basic/Smart Line Module	A	99	117	140	175
- Active Line Module	A	89	105	126	157
Base load current I_{HDC} when fed via					
- Basic/Smart Line Module	A	90	106	128	160
- Active Line Module	A	81	96	115	144
Supply voltages		675 ... 1035			
- DC-link voltage	V_{DC}	24 (20.4 ... 28.8)			
- Electronic power supply	V_{DC}	0 ... 0.72 x DC-link voltage			
- Output voltage	V_{ACrms}				
Rated pulse frequency	kHz	1.25	1.25	1.25	1.25
- Max. pulse frequency without derating	kHz	1.25	1.25	1.25	1.25
- Max. pulse frequency with derating	kHz	7.5	7.5	7.5	7.5
Max. ambient temperature					
- Without derating	°C	40	40	40	40
- With derating	°C	55	55	55	55
DC-link capacitance	µF	1200	1200	1600	2800
Current consumption					
- Electronics current consumption (24 V DC)	A	0.8	0.8	0.8	0.8
- Fan supply, at 2 AC 690 V, 50/60 Hz	A	0.4 / 0.6	0.4 / 0.6	0.4 / 0.6	0.4 / 0.6
Power loss, max. ³⁾					
- at 50 Hz 690 V	kW	1.17	1.43	1.89	1.80
- at 60 Hz 575 V	kW	1.1	1.3	1.77	1.62
Cooling air requirement	m ³ /s	0.17	0.17	0.17	0.17
Sound pressure level					
L_{pA} (1 m) at 50/60 Hz	dB(A)	64 / 67	64 / 67	64 / 67	64 / 67

Article number	6SL3320-	1TG28-5AA3	1TG31-0AA3	1TG31-2AA3	1TG31-5AA3
Connections					
- DC-link connection		M10	M10	M10	M10
- Motor connection		M10	M10	M10	M10
- PE connection PE1		M10	M10	M10	M10
- PE connection PE2		M10	M10	M10	M10
Max. conductor cross-sections					
- DC-link connection (DCP, DCN)	mm ²	2 x 185	2 x 185	2 x 185	2 x 185
- Motor connection (U2, V2, W2)	mm ²	2 x 185	2 x 185	2 x 185	2 x 185
- PE connection PE1	mm ²	2 x 185	2 x 185	2 x 185	2 x 185
- PE connection PE2	mm ²	2 x 185	2 x 185	2 x 185	2 x 185
Max. motor cable length					
- Shielded	m	300	300	300	300
- Unshielded	m	450	450	450	450
Degree of protection		IP20	IP20	IP20	IP20
Dimensions					
- Width	mm	326	326	326	326
- Height	mm	1400	1400	1400	1400
- Depth	mm	356	356	356	356
Frame size		FX	FX	FX	FX
Weight	kg	95	95	95	95

- 1) Rated power of a typical 6-pole standard induction motor based on I_L or I_H at 3 AC 500 V or 690 V 50 Hz.
- 2) Rated power of a typical 6-pole standard induction motor based on I_L or I_H at 3 AC 575 V 60 Hz.
- 3) The specified power loss is the maximum value at 100% capacity utilization. The value in normal operation is lower.

5.6 Technical specifications

Table 5- 17 Technical data for Motor Modules, 675 ... 1035 V DC (line voltage 3 AC 500 ... 690 V), Part 2

Article number	6SL3320-	1TG31-8AA3	1TG32-2AA3	1TG32-6AA3	1TG33-3AA3
Output current					
- Rated current I_{NA}	A	175	215	260	330
- Base load current I_L	A	171	208	250	320
- Base load current I_H	A	157	192	233	280
- Max. output current I_{max}	A	255	312	375	480
Type rating					
- Based on I_L (50 Hz 690 V) ¹⁾	kW	160	200	250	315
- Based on I_H (50 Hz 690 V) ¹⁾	kW	132	160	200	250
- Based on I_L (50 Hz 500 V) ¹⁾	kW	110	132	160	200
- Based on I_H (50 Hz 500 V) ¹⁾	kW	90	110	132	160
- Based on I_L (60 Hz 575 V) ²⁾	HP	150	200	250	300
- Based on I_H (60 Hz 575 V) ²⁾	HP	150	200	200	250
DC-link current					
Rated current I_{NDC} when fed via					
- Basic/Smart Line Module	A	210	258	312	396
- Active Line Module	A	189	232	281	356
Base load current I_{LDC} when fed via					
- Basic/Smart Line Module	A	204	251	304	386
- Active Line Module	A	184	226	273	347
Base load current I_{HDC} when fed via					
- Basic/Smart Line Module	A	186	229	277	352
- Active Line Module	A	168	206	250	316
Supply voltages		675 ... 1035			
- DC-link voltage	V_{DC}	24 (20.4 ... 28.8)			
- Electronic power supply	V_{DC}	0 ... 0.72 x DC-link voltage			
- Output voltage	V_{ACrms}				
Rated pulse frequency					
- Max. pulse frequency without derating	kHz	1.25	1.25	1.25	1.25
- Max. pulse frequency with derating	kHz	1.25	1.25	1.25	1.25
	kHz	7.5	7.5	7.5	7.5
Max. ambient temperature					
- Without derating	°C	40	40	40	40
- With derating	°C	55	55	55	55
DC-link capacitance	µF	2800	2800	3900	4200
Current consumption					
- Electronics current consumption (24 V DC)	A	0.9	0.9	0.9	0.9
- Fan supply, at 2 AC 690 V, 50/60 Hz	A	1.0 / 1.5	1.0 / 1.5	1.0 / 1.5	1.0 / 1.5
Power loss, max. ³⁾					
- at 50 Hz 690 V	kW	2.67	3.09	3.62	4.34
- at 60 Hz 575 V	kW	2.5	2.91	3.38	3.98
Cooling air requirement	m³/s	0.36	0.36	0.36	0.36
Sound pressure level					
L_{pA} (1 m) at 50/60 Hz	dB(A)	69 / 73	69 / 73	69 / 73	69 / 73
Connections					
- DC-link connection		M10	M10	M10	M10
- Motor connection		M10	M10	M10	M10
- PE connection PE1		M10	M10	M10	M10
- PE connection PE2		M10	M10	M10	M10

Article number	6SL3320-	1TG31-8AA3	1TG32-2AA3	1TG32-6AA3	1TG33-3AA3
Max. conductor cross-sections					
- DC-link connection (DCP, DCN)	mm ²	2 x 240	2 x 240	2 x 240	2 x 240
- Motor connection (U2, V2, W2)	mm ²	2 x 240	2 x 240	2 x 240	2 x 240
- PE connection PE1	mm ²	2 x 240	2 x 240	2 x 240	2 x 240
- PE connection PE2	mm ²	2 x 240	2 x 240	2 x 240	2 x 240
Max. motor cable length					
- Shielded	m	300	300	300	300
- Unshielded	m	450	450	450	450
Degree of protection		IP20	IP20	IP20	IP20
Dimensions					
- Width	mm	326	326	326	326
- Height	mm	1533	1533	1533	1533
- Depth	mm	545	545	545	545
Frame size		GX	GX	GX	GX
Weight	kg	136	136	136	136

- 1) Rated power of a typical 6-pole standard induction motor based on I_L or I_H at 3 AC 500 V or 690 V 50 Hz.
- 2) Rated power of a typical 6-pole standard induction motor based on I_L or I_H at 3 AC 575 V 60 Hz.
- 3) The specified power loss is the maximum value at 100% capacity utilization. The value in normal operation is lower.

5.6 Technical specifications

Table 5- 18 Technical data for Motor Modules, 675 ... 1035 V DC (line voltage 3 AC 500 ... 690 V), Part 3

Article number	6SL3320-	1TG34-1AA3	1TG34-7AA3	1TG35-8AA3	1TG37-4AA3
Output current					
- Rated current I_{NA}	A	410	465	575	735
- Base load current I_L	A	400	452	560	710
- Base load current I_H	A	367	416	514	657
- Max. output current I_{max}	A	600	678	840	1065
Type rating					
- Based on I_L (50 Hz 690 V) ¹⁾	kW	400	450	560	710
- Based on I_H (50 Hz 690 V) ¹⁾	kW	315	400	450	630
- Based on I_L (50 Hz 500 V) ¹⁾	kW	250	315	400	500
- Based on I_H (50 Hz 500 V) ¹⁾	kW	200	250	315	450
- Based on I_L (60 Hz 575 V) ²⁾	HP	400	450	600	700
- Based on I_H (60 Hz 575 V) ²⁾	HP	350	450	500	700
DC-link current					
Rated current I_{NDC} when fed via					
- Basic/Smart Line Module	A	492	558	690	882
- Active Line Module	A	443	502	621	794
Base load current I_{LDC} when fed via					
- Basic/Smart Line Module	A	479	544	672	859
- Active Line Module	A	431	489	605	774
Base load current I_{HDC} when fed via					
- Basic/Smart Line Module	A	437	496	614	784
- Active Line Module	A	394	446	552	706
Supply voltages		675 ... 1035			
- DC-link voltage	V_{DC}	24 (20.4 ... 28.8)			
- Electronic power supply	V_{DC}	0 ... 0.72 x DC-link voltage			
- Output voltage	V_{ACrms}				
Rated pulse frequency					
- Max. pulse frequency without derating	kHz	1.25	1.25	1.25	1.25
- Max. pulse frequency with derating	kHz	7.5	7.5	7.5	7.5
Max. ambient temperature					
- Without derating	°C	40	40	40	40
- With derating	°C	55	55	55	55
DC-link capacitance	µF	7400	7400	7400	11100
Current consumption					
- Electronics current consumption (24 V DC)	A	1.0	1.0	1.0	1.25
- Fan supply, at 2 AC 690 V, 50/60 Hz	A	2.1 / 3.1	2.1 / 3.1	2.1 / 3.1	3.1 / 4.6
Power loss, max. ³⁾					
- at 50 Hz 690 V	kW	6.13	6.80	10.3	10.9
- at 60 Hz 575 V	kW	5.71	6.32	9.7	10.0
Cooling air requirement	m³/s	0.78	0.78	0.78	1.08
Sound pressure level					
L_{pA} (1 m) at 50/60 Hz	dB(A)	70 / 73	70 / 73	70 / 73	71 / 73
Connections					
- DC-link connection		4 x M10	4 x M10	4 x M10	4 x M10
- Motor connection		2 x M12	2 x M12	2 x M12	3 x M12
- PE connection PE1		M12	M12	M12	M12
- PE connection PE2		2 x M12	2 x M12	2 x M12	3 x M12

Article number	6SL3320-	1TG34-1AA3	1TG34-7AA3	1TG35-8AA3	1TG37-4AA3
Max. conductor cross-sections					
- DC-link connection (DCP, DCN)	mm ²	Busbar	Busbar	Busbar	Busbar
- Motor connection (U2, V2, W2)	mm ²	4 x 240	4 x 240	4 x 240	6 x 240
- PE connection PE1	mm ²	1 x 240	1 x 240	1 x 240	1 x 240
- PE connection PE2	mm ²	2 x 240	2 x 240	2 x 240	3 x 240
Max. motor cable length					
- Shielded	m	300	300	300	300
- Unshielded	m	450	450	450	450
Degree of protection		IP00	IP00	IP00	IP00
Dimensions					
- Width	mm	503	503	503	704
- Height	mm	1475	1475	1475	1475
- Depth	mm	547	547	547	550
Frame size		HX	HX	HX	JX
Weight	kg	290	290	290	450

- 1) Rated power of a typical 6-pole standard induction motor based on I_L or I_H at 3 AC 500 V or 690 V 50 Hz.
- 2) Rated power of a typical 6-pole standard induction motor based on I_L or I_H at 3 AC 575 V 60 Hz.
- 3) The specified power loss is the maximum value at 100% capacity utilization. The value in normal operation is lower.

5.6 Technical specifications

Table 5- 19 Technical data for Motor Modules, 675 ... 1035 V DC (line voltage 3 AC 500 ... 690 V), Part 4

Article number	6SL3320-	1TG38-1AA3	1TG38-8AA3	1TG41-0AA3	1TG41-3AA3
Output current					
- Rated current I _{NA}	A	810	910	1025	1270
- Base load current I _L	A	790	880	1000	1230
- Base load current I _H	A	724	814	917	1136
- Max. output current I _{max}	A	1185	1320	1500	1845
Type rating					
- Based on I _L (50 Hz 690 V) ¹⁾	kW	800	900	1000	1200
- Based on I _H (50 Hz 690 V) ¹⁾	kW	710	800	900	1000
- Based on I _L (50 Hz 500 V) ¹⁾	kW	560	630	710	900
- Based on I _H (50 Hz 500 V) ¹⁾	kW	500	560	630	800
- Based on I _L (60 Hz 575 V) ²⁾	HP	800	900	1000	1250
- Based on I _H (60 Hz 575 V) ²⁾	HP	700	800	900	1000
DC-link current					
Rated current I _{ND} DC when fed via					
- Basic/Smart Line Module	A	972	1092	1230	1524
- Active Line Module	A	875	983	1107	1372
Base load current I _L DC when fed via					
- Basic/Smart Line Module	A	947	1064	1199	1485
- Active Line Module	A	853	958	1079	1337
Base load current I _H DC when fed via					
- Basic/Smart Line Module	A	865	971	1094	1356
- Active Line Module	A	778	874	985	1221
Supply voltages		675 ... 1035			
- DC-link voltage	V _{DC}	24 (20.4 ... 28.8)			
- Electronic power supply	V _{DC}	0 ... 0.72 x DC-link voltage			
- Output voltage	V _{ACrms}				
Rated pulse frequency					
- Max. pulse frequency without derating	kHz	1.25	1.25	1.25	1.25
- Max. pulse frequency with derating	kHz	1.25	1.25	1.25	1.25
	kHz	7.5	7.5	7.5	7.5
Max. ambient temperature					
- Without derating	°C	40	40	40	40
- With derating	°C	55	55	55	55
DC-link capacitance	µF	11100	14400	14400	19200
Current consumption					
- Electronics current consumption (24 V DC)	A	1.25	1.4	1.4	1.4
- Fan supply, at 2 AC 690 V, 50/60 Hz	A	3.1 / 4.6	3.1 / 4.6	3.1 / 4.6	3.1 / 4.6
Power loss, max. ³⁾					
- at 50 Hz 690 V	kW	11.5	11.7	13.2	16.0
- at 60 Hz 575 V	kW	10.5	10.6	12.0	14.2
Cooling air requirement	m³/s	1.08	1.08	1.08	1.08
Sound pressure level					
L _{pA} (1 m) at 50/60 Hz	dB(A)	71 / 73	71 / 73	71 / 73	71 / 73
Connections					
- DC-link connection		4 x M10	4 x M10	4 x M10	4 x M10
- Motor connection		3 x M12	3 x M12	3 x M12	3 x M12
- PE connection PE1		M12	M12	M12	M12
- PE connection PE2		3 x M12	3 x M12	3 x M12	3 x M12

Article number	6SL3320–	1TG38–1AA3	1TG38–8AA3	1TG41–0AA3	1TG41–3AA3
Max. conductor cross-sections					
- DC-link connection (DCP, DCN)	mm ²	Busbar	Busbar	Busbar	Busbar
- Motor connection (U2, V2, W2)	mm ²	6 x 240	6 x 240	6 x 240	6 x 240
- PE connection PE1	mm ²	1 x 240	1 x 240	1 x 240	1 x 240
- PE connection PE2	mm ²	3 x 240	3 x 240	3 x 240	3 x 240
Max. motor cable length					
- Shielded	m	300	300	300	300
- Unshielded	m	450	450	450	450
Degree of protection		IP00	IP00	IP00	IP00
Dimensions					
- Width	mm	704	704	704	704
- Height	mm	1475	1475	1475	1475
- Depth	mm	550	550	550	550
Frame size		JX	JX	JX	JX
Weight	kg	450	450	450	450

- 1) Rated power of a typical 6-pole standard induction motor based on I_L or I_H at 3 AC 500 V or 690 V 50 Hz.
- 2) Rated power of a typical 6-pole standard induction motor based on I_L or I_H at 3 AC 575 V 60 Hz.
- 3) The specified power loss is the maximum value at 100% capacity utilization. The value in normal operation is lower.

5.6.3 Overload capability

The Motor Modules have an overload reserve e.g. to handle breakaway torques.

In the case of drives with overload requirements, the appropriate base-load current must, therefore, be used as a basis for the required load.

The criterion for overload is that the Motor Module is operated with its base load current before and after the overload occurs (a load duration of 300 s is used as a basis here).

Another precondition is that the Motor Module is operated at its factory-set pulse frequency at output frequencies >10 Hz.

For additional information on the overload capability, see the Low Voltage Configuration Manual.

Low overload

The base load current for low overload (I_L) is based on a load duty cycle of 110% for 60 s or 150% for 10 s.

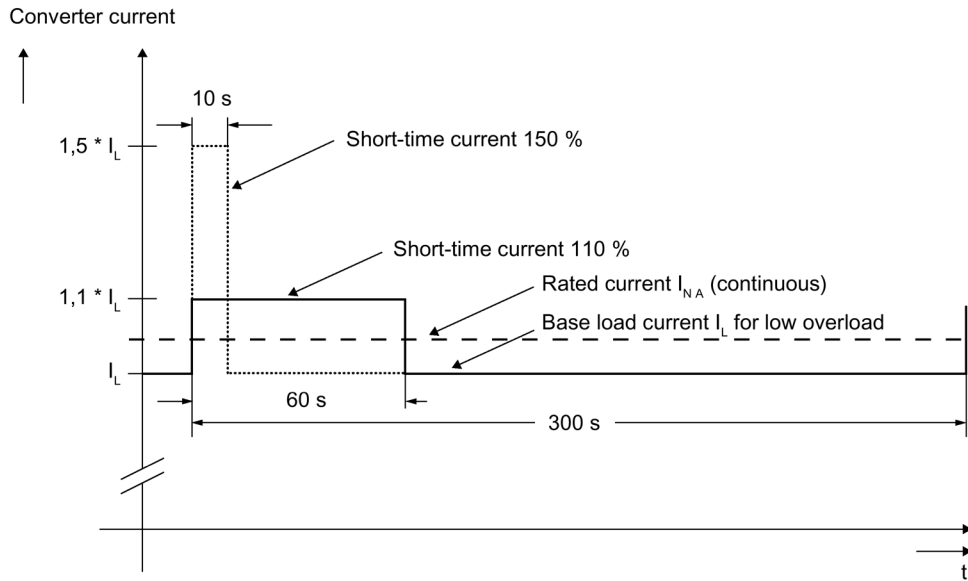

Figure 5-11 Low overload

High overload

The base load current for a high overload I_H is based on a duty cycle of 150% for 60 s or 160% for 10 s.

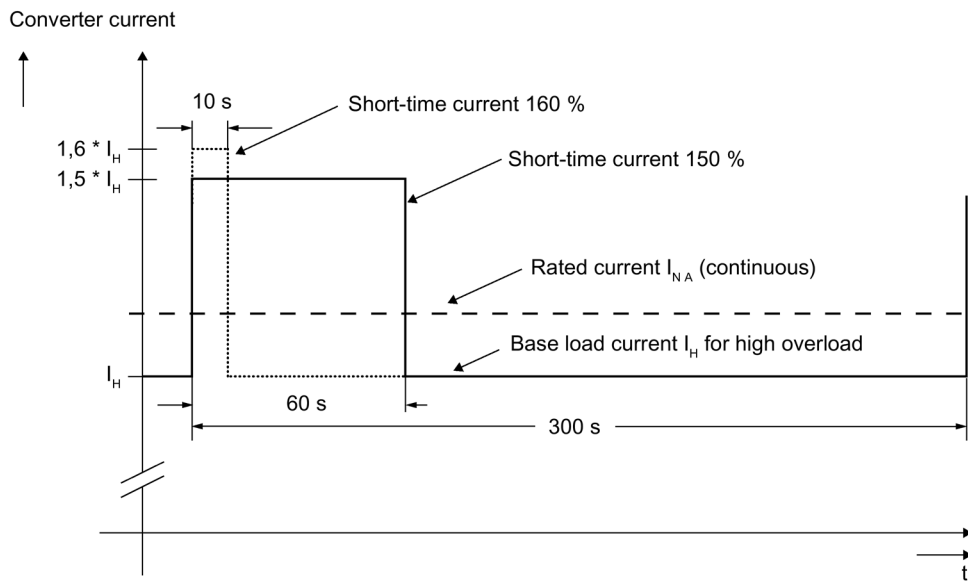

Figure 5-12 High overload

5.6.4 Current de-rating depending on the pulse frequency

When the pulse frequency is increased, the derating factor of the output current must be taken into account. This derating factor must be applied to the currents specified in the technical data for Motor Modules.

Table 5- 20 Derating factor of the output current as a function of the pulse frequency for devices with a rated pulse frequency of 2 kHz

Article No.	Type rating	Output current at 2 kHz	Derating factor at the pulse frequency					
			2.5 kHz	4 kHz	5 kHz	7.5 kHz	8 kHz	
6SL3320-...	[kW]	[A]						
Connection voltage 510 ... 720 V DC (line voltage 3 AC 380 ... 480 V)								
1TE32-1AA3	110	210	95%	82%	74%	54%	50%	
1TE32-6AA3	132	260	95%	83%	74%	54%	50%	
1TE33-1AA3	160	310	97%	88%	78%	54%	50%	
1TE33-8AA3	200	380	96%	87%	77%	54%	50%	
1TE35-0AA3	250	490	94%	78%	71%	53%	50%	
1TE41-4AS3	800	1330	88%	55%	--	--	--	

Table 5- 21 Derating factor of the output current as a function of the pulse frequency for devices with a rated pulse frequency of 1.25 kHz

Article No.	Type rating	Output current at 1.25 kHz	Derating factor at the pulse frequency					
			2 kHz	2.5 kHz	4 kHz	5 kHz	7.5 kHz	8 kHz
6SL3320-...	[kW]	[A]						
Connection voltage 510 ... 720 V DC (line voltage 3 AC 380 ... 480 V)								
1TE36-1AA3	315	605	83%	72%	64%	60%	40%	36%
1TE37-5AA3	400	745	83%	72%	64%	60%	40%	36%
1TE38-4AA3	450	840	87%	79%	64%	55%	40%	37%
1TE41-0AA3	560	985	92%	87%	70%	60%	50%	47%
1TE41-2AA3	710	1260	92%	87%	70%	60%	50%	47%
1TE41-4AA3	800	1405	97%	95%	74%	60%	50%	47%
Connection voltage 675 ... 1035 V DC (line voltage 3 AC 500 ... 690 V)								
1TG28-5AA3	75	85	93%	89%	71%	60%	40%	--
1TG31-0AA3	90	100	92%	88%	71%	60%	40%	--
1TG31-2AA3	110	120	92%	88%	71%	60%	40%	--
1TG31-5AA3	132	150	90%	84%	66%	55%	35%	--
1TG31-8AA3	160	175	92%	87%	70%	60%	40%	--
1TG32-2AA3	200	215	92%	87%	70%	60%	40%	--
1TG32-6AA3	250	260	92%	88%	71%	60%	40%	--
1TG33-3AA3	315	330	89%	82%	65%	55%	40%	--
1TG34-1AA3	400	410	89%	82%	65%	55%	35%	--
1TG34-7AA3	450	465	92%	87%	67%	55%	35%	--
1TG35-8AA3	560	575	91%	85%	64%	50%	35%	--
1TG37-4AA3	710	735	87%	79%	64%	55%	25%	--

Article No.	Type rating	Output current at 1.25 kHz	Derating factor at the pulse frequency					
			2 kHz	2.5 kHz	4 kHz	5 kHz	7.5 kHz	8 kHz
6SL3320-...	[kW]	[A]						
1TG38-1AA3	800	810	97%	95%	71%	55%	35%	--
1TG38-8AA3	900	910	92%	87%	67%	55%	33%	--
1TG41-0AA3	1000	1025	91%	86%	64%	50%	30%	--
1TG41-3AA3	1200	1270	87%	79%	55%	40%	25%	--

Note

Derating factors for pulse frequencies in the range between two fixed values

For pulse frequencies in the range between the specified fixed values, the relevant derating factors can be determined by linear interpolation.

Maximum output frequencies achieved by increasing the pulse frequency

The adjustable pulse frequencies - and therefore the output frequencies that can be achieved with the factory-set current controller clock cycles - are listed below.

Current controller clock cycle T_i	Adjustable pulse frequencies f_p	Maximum achievable output frequency f_A		
		V/f operating mode	Vector operating mode	Servo mode
250 μ s ¹⁾	2 kHz	166 Hz	166 Hz	333 Hz
	4 kHz	333 Hz	333 Hz	550 Hz ³⁾
	8 kHz	550 Hz ³⁾	480 Hz	550 Hz ³⁾
400 μ s ²⁾	1.25 kHz	104 Hz	104 Hz	-
	2.50 kHz	208 Hz	208 Hz	-
	5.00 kHz	416 Hz	300 Hz	-
	7.50 kHz	550 Hz ³⁾	300 Hz	-

- 1) As factory setting, the following devices have a current controller clock cycle of 250 μ s - and a pulse frequency of 2 kHz:
- 510 ... 720 V DC: \leq 250 kW / 490 A
- 2) As factory setting, the following devices have a current controller clock cycle of 400 μ s - and a pulse frequency of 1.25 kHz:
- 510 ... 720 V DC: \geq 315 kW / 605 A
- 675 ... 1035 V DC: All power ratings
- 3) With the "High output frequencies" license, which can be ordered as option J01 on the CompactFlash card for SINAMICS S120, the maximum output frequency is increased up to 650 Hz.

Refer to the Low Voltage Configuration Manual for current controller clock cycles deviating from the factory setting.

5.6.5 Parallel connection of Motor Modules

The following rules must be observed when connecting Motor Modules in parallel:

- Up to four identical Motor Modules can be connected in parallel.
- A common Control Unit is required whenever the modules are connected in parallel.
- The motor supply cables must have the same length (symmetrical design).
- Power must be supplied to the Motor Modules from a common DC link.
- For motors with a single winding system, supply cables with a minimum length or motor reactors must be used. The cable lengths are listed in the following tables.
- A derating factor of 5% must be taken into consideration, regardless of the number of Motor Modules connected in parallel.

Note

Mixed operation is not possible

It is only possible to connect identical power units in parallel if all power units have the same hardware version. Mixed operation between a power unit with Control Interface Module (article number 6SL33xx-xxxxx-xAA3) and a power unit with Control Interface Board (article number 6SL33xx-xxxxx-xAA0) is not possible.

Minimum cable lengths for parallel connection and connection to a motor with a single-winding system

Note

Minimum cable lengths

The minimum cable lengths specified in the tables below must be observed when two or more Motor Modules are connected in parallel and there is a connection to a motor with a single-winding system. If the cable length required for the application cannot be achieved, a motor reactor must be provided.

Table 5- 22 Motor Modules, DC 510 ... 720 V (line voltage 3 AC 380 ... 480 V)

Article number	Type rating [kW]	Output current [A]	Minimum cable length [m]
6SL3320-1TE32-1AA3	110	210	30
6SL3320-1TE32-6AA3	132	260	27
6SL3320-1TE33-1AA3	160	310	20
6SL3320-1TE33-8AA3	200	380	17
6SL3320-1TE35-0AA3	250	490	15
6SL3320-1TE36-1AA3	315	605	13
6SL3320-1TE37-5AA3	400	745	10
6SL3320-1TE38-4AA3	450	840	9
6SL3320-1TE41-0AA3	560	985	8
6SL3320-1TE41-2AA3	710	1260	6
6SL3320-1TE41-4AA3	800	1405	5
6SL3320-1TE41-4AS3	800	1330	5

Table 5- 23 Motor Modules, DC 675 ... 1035 V (line voltage 3 AC 500 ... 690 V)

Article number	Type rating [kW]	Output current [A]	Minimum cable length [m]
6SL3320-1TG28-5AA3	75	85	100
6SL3320-1TG31-0AA3	90	100	90
6SL3320-1TG31-2AA3	110	120	80
6SL3320-1TG31-5AA3	132	150	70
6SL3320-1TG31-8AA3	160	175	60
6SL3320-1TG32-2AA3	200	215	50
6SL3320-1TG32-6AA3	250	260	40
6SL3320-1TG33-3AA3	315	330	30
6SL3320-1TG34-1AA3	400	410	25
6SL3320-1TG34-7AA3	450	465	25
6SL3320-1TG35-8AA3	560	575	20
6SL3320-1TG37-4AA3	710	735	18
6SL3320-1TG38-1AA3	800	810	15
6SL3320-1TG38-8AA3	900	910	12
6SL3320-1TG41-0AA3	1000	1025	10
6SL3320-1TG41-3AA3	1200	1270	8

Motor Modules Chassis-2

6.1 Description

A Motor Module is a power unit (DC-AC inverter) that provides the power supply for the motor connected to it. The power supply is realized through the DC link of the drive unit. A Motor Module must be connected to a Control Unit via DRIVE-CLiQ. The open-loop and closed-loop control functions are implemented in the Control Unit.



Figure 6-1 Motor Module Chassis-2, frame size FS4

6.1 Description

Operating principle

Motor Modules are designed for multi-axis drive systems and are controlled by either a CU320-2 or a SIMOTION D Control Unit. Motor Modules are interconnected by means of a shared DC busbar.

One or more Motor Modules are supplied with energy for the motors via the DC link. Both synchronous and induction motors can be operated.

Since the Motor Modules share the same DC link, they can exchange energy with one another, i.e. if one Motor Module operating in generator mode produces energy, the energy can be used by another Motor Module operating in motor mode. The DC link is supplied with line voltage by a Line Module.

Characteristics of the Motor Modules

- Version for 510 ... 720 V DC (line voltage 3 AC 380 ... 480 V) from 975 to 1200 A
- Internal air cooling, the fan does not run permanently, only when required.
- Short-circuit/ground-fault-proof
- Electronic rating plate
- Operating status and error status via LEDs
- DRIVE-CLiQ interface for communication with the Control Unit and/or other components in the drive line-up
- Integration in system diagnostics

Note

"Safety Integrated" function

The "Safety Integrated" (Basic/Advanced) safety functions will be released as from firmware V5.1 SP1 (mid-2018).

6.2 Safety information



WARNING

Not observing fundamental safety instructions and residual risks

Not observing fundamental safety instructions and residual risks listed in Chapter 1 can result in accidents with severe injuries or death.

- Comply with the fundamental safety instructions.
- When assessing the risk, take into account remaining risks.

WARNING

High leakage currents when the protective conductor in the line feeder cable is interrupted

The drive components conduct a high leakage current via the protective conductor. Touching conductive parts when the protective conductor is interrupted can result in death or serious injury.

- Ensure that the external protective conductor satisfies at least one of the following conditions:
 - It has been installed so that it is protected against mechanical damage. ¹⁾
 - For an individual core, it has a cross-section of at least 10 mm² Cu.
 - If it is a conductor of a multi-conductor cable, it has a cross-section of at least 2.5 mm² Cu.
 - It has a second protective conductor in parallel with the same cross-section.
 - It complies with the local regulations for equipment with increased leakage current.
- ¹⁾ Cables laid within control cabinets or closed machine housings are considered to be adequately protected from mechanical damage.

WARNING

Fire due to inadequate ventilation clearances

Inadequate ventilation clearances can cause overheating with a risk for personnel through smoke development and fire. This can also result in more downtimes and reduced service lives of Line Modules.

- Observe the ventilation clearances above, below and in front of the Motor Modules, which are specified in the dimension drawings.

CAUTION

Fire due to overheating when the total length of the power cables is exceeded

Overheating and a fire can result when the total length of the power cables is exceeded.

- Ensure that the total length of the power cables (motor feeder cables and DC link cables) does not exceed the values specified in the technical data.



! CAUTION
Burns resulting from high surface temperatures
Depending on the ambient temperature, the temperature at the device housing can exceed 60 °C. Contact with the surface can result in severe burns.
<ul style="list-style-type: none">• Before starting work on the equipment, always check the temperature of the housing.

NOTICE
Material damage caused by loose power connections
Insufficient tightening torques or vibration can result in faulty electrical connections. This can cause fire damage or malfunctions.
<ul style="list-style-type: none">• Tighten all power connections with the specified tightening torques, e.g. line supply connection, motor connection, DC link connections.• Check the tightening torques of all power connections at regular intervals and tighten them when required. This applies in particular after transport.

NOTICE
Damage to the devices when performing a voltage test as a result of connections that are not disconnected
As part of routine tests, SINAMICS S components undergo a voltage test according to EN 61800-5-1. Connected devices can be damaged.
<ul style="list-style-type: none">• Disconnect or unplug all SINAMICS devices before the voltage test of the machine equipment according to EN 60204-1, Section 18.4.

NOTICE
Damage through use of incorrect DRIVE-CLiQ cables
Damage or malfunctions can occur on the devices or system when DRIVE-CLiQ cables are used that are either incorrect or have not been released for this purpose.
<ul style="list-style-type: none">• Only use suitable DRIVE-CLiQ cables that have been released by Siemens for the particular application.

Note
Fan can start automatically

When the power supply is available and the pulses are enabled, depending on the ambient temperature, the fan can start automatically.

6.3 Interface description

6.3.1 Overview

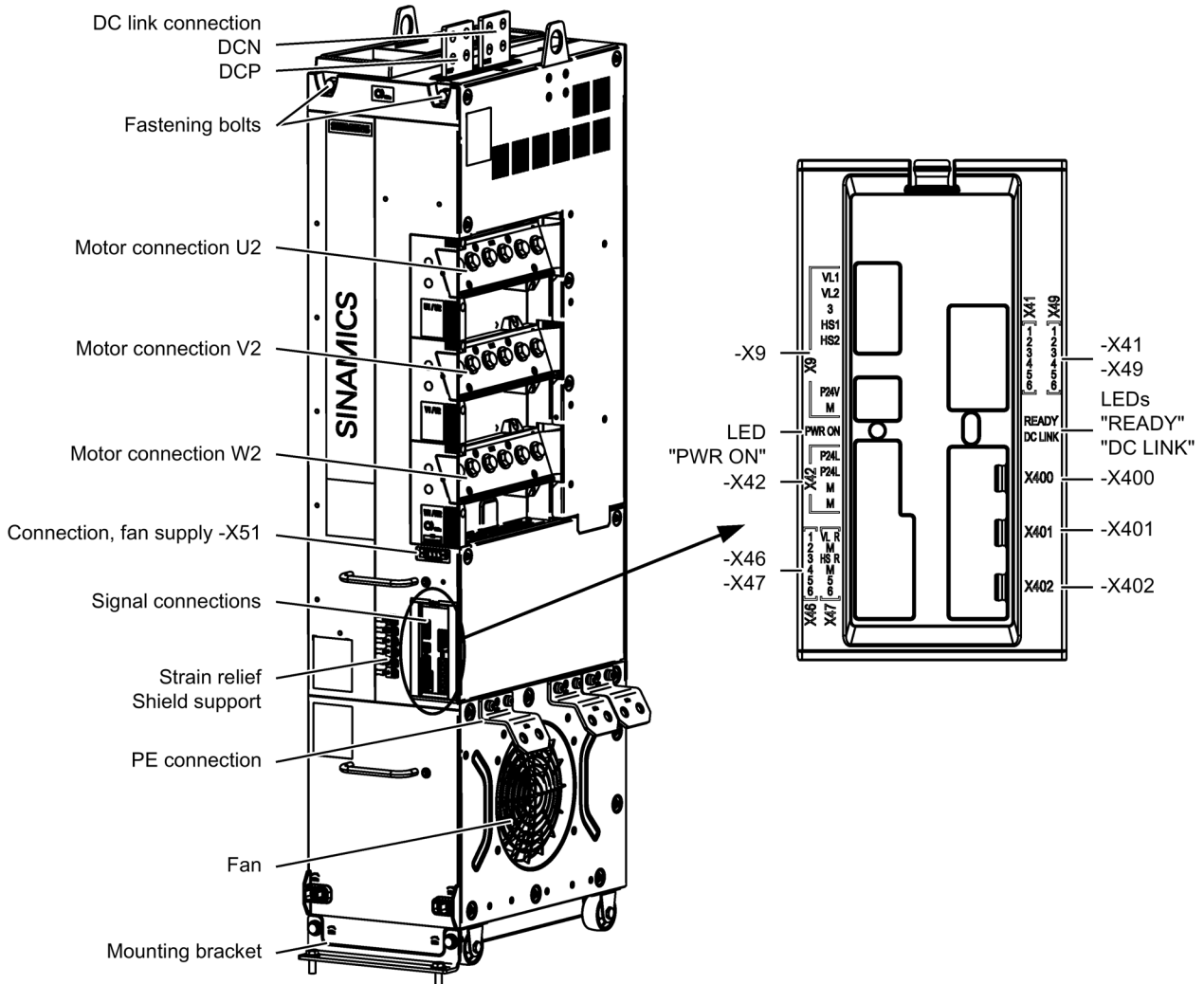

Figure 6-2 Motor Module, frame size FS4

6.3.2 Connection example

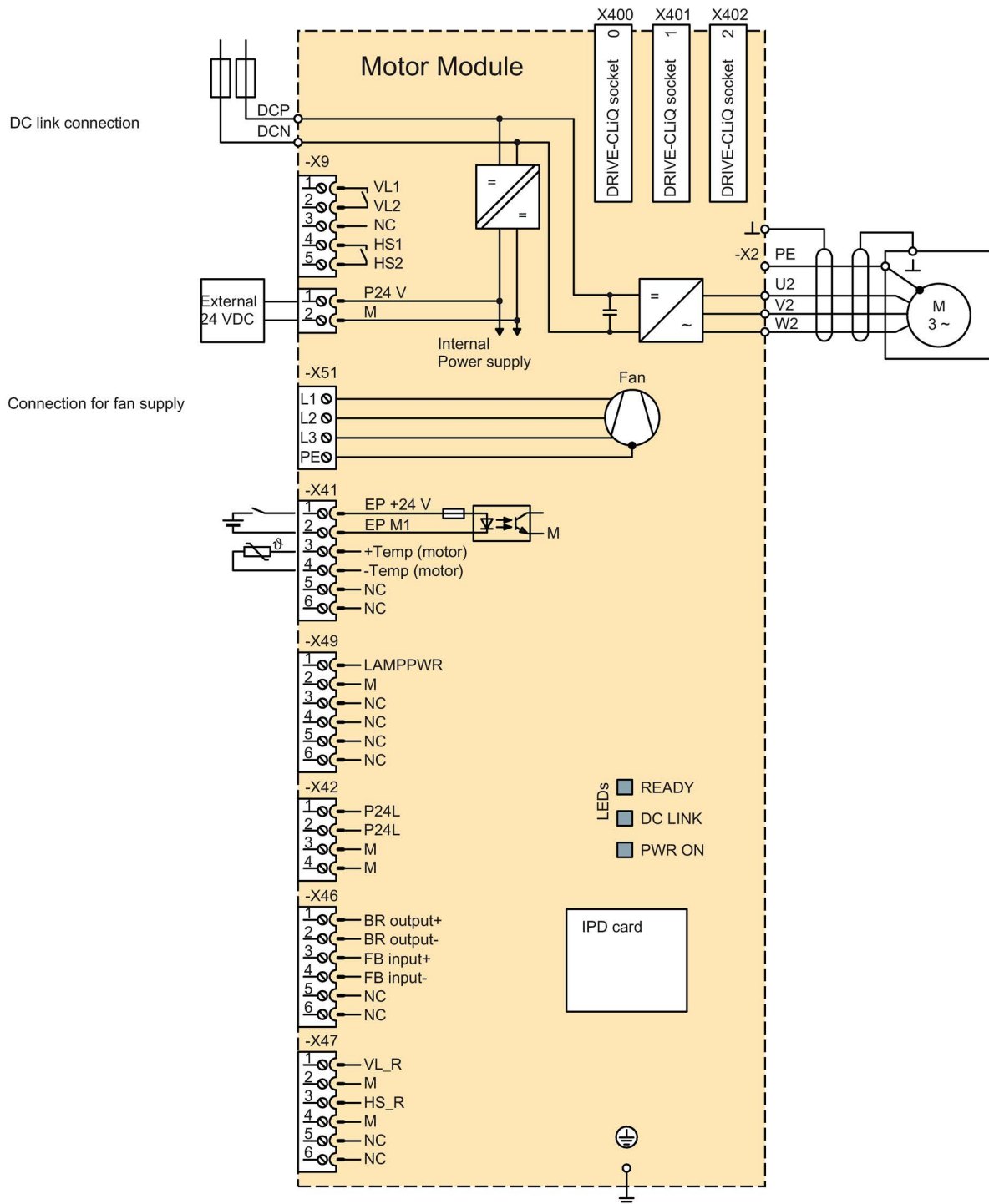



Figure 6-3 Connection example, Motor Modules Chassis-2

6.3.3 DC link/motor connection

Table 6- 1 DC link / motor connection of Motor Modules Chassis-2

Terminals	Technical specifications
DCP, DCN DC power input	<p>Voltage:</p> <ul style="list-style-type: none"> 510 ... 720 V DC <p>Connections:</p> <ul style="list-style-type: none"> Frame size FS4: d = 14 mm (M12 / 50 Nm) flat connector for busbar connection <p>When connecting using copper busbars, the same cross-sections should be used as the connecting busbars of the device itself:</p> <ul style="list-style-type: none"> Frame size FS4: 80 mm x 8 mm <p>The DC link must be protected (fused) on the plant/system side.</p>
U2, V2, W2 3 AC power output	<p>Voltage:</p> <ul style="list-style-type: none"> 0 V 3 AC to 0.72 x DC link voltage <p>Connecting thread:</p> <ul style="list-style-type: none"> Frame size FS4: M12 / 50 Nm for cable lugs in accordance with DIN 46234 / DIN 46235 ¹⁾
PE connection PE1, PE2	<p>Connecting thread:</p> <ul style="list-style-type: none"> Frame size FS4: M12 / 50 Nm for cable lugs in accordance with DIN 46234 / DIN 46235 ¹⁾

¹⁾ Dimensions for connecting alternative cable lugs, see "cable lugs" in the appendix.

 WARNING
<p>Electric shock if unsuitable screws are used to connect the motor</p> <p>The plastic enclosure behind the motor connections can be damaged if screws longer than 40 mm are used. This represents danger to life, and equipment can be damaged.</p> <ul style="list-style-type: none"> Only use the original M12x40 screws, including the spring washer, when connecting the motor cables. If you have to replace screws, then only use screws with the same length. Always use a spring washer.

6.3.4 X51 connection, fan power supply

Table 6- 2 Terminal strip X51, fan power supply connection

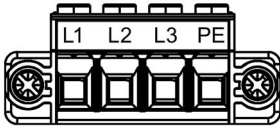
	Terminal	Function	Technical specifications
	L1	L1	Supply voltage: 3 AC 380 V ... 480 V
	L2	L2	Frequency: 47 ... 63 Hz
	L3	L3	Max. load current: 1.8 A
	PE	PE	Connection is connected to the fan housing.
Max. connectable cross-section: 6.0 mm ²			

A 3-pole 16 A miniature circuit breaker, with a tripping characteristic Class C is recommended to protect the fan power supply.

Note

After installation, screw on the connector.

Note

Connect the PE connection with the PE connection of the electrical cabinet.

Note

When connected to an ungrounded line supply (IT system), an isolating transformer must be connected upstream of the fan power supply.

Note

For installation altitudes exceeding 2000 m, an isolating transformer must be connected upstream of the fan power supply.

6.3.5 X9 terminal strip

Table 6- 3 Terminal strip X9

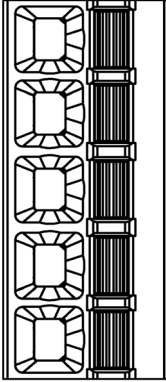
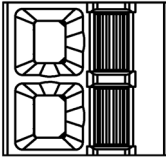
	Terminal	Signal name	Technical specifications
	VL1	VL1	240 V AC: 8 A max. 24 V DC: max. 1 A isolated
	VL2	VL2	
	NC	NC	Reserved, do not use
	HS1	HS1	240 V AC: 8 A max. 24 V DC: max. 1 A isolated
	HS2	HS2	
	P24V	P24V	External 24 V DC supply Voltage: 24 V DC (20.4 ... 28.8 V) Current consumption: max. 1.6 A
	M	M	
Max. connectable cross-section: 2.5 mm ²			

6.3.6 X41 EP terminal / temperature sensor connection

Table 6- 4 Terminal strip X41

	Terminal	Function	Technical specifications
	1	EP +24 V (enable pulses)	Supply voltage: 24 V DC (20.4 ... 28.8 V) Current consumption: 10 mA
	2	EP M1 (enable pulses)	The pulse inhibit function is only available when Safety Integrated Basic Functions are enabled.
	3	+Temp (motor)	Temperature sensor connection: KTY84-1C130 / PT100 / PT1000 / PTC
	4	-Temp (motor)	
	5	NC	Reserved, do not use
	6	NC	Reserved, do not use

Max. connectable cross-section: 1.5 mm²

The terminal strip is coded at terminal 4; please use the corresponding connector from the accessory pack.



! WARNING

Electric shock in the event of voltage flashovers at the temperature sensor

Voltage flashovers in the signal electronics can occur in motors without safe electrical separation of the temperature sensors.

- Only use temperature sensors that fully comply with the specifications of the safety isolation.
- If safe electrical separation cannot be guaranteed (for linear motors or third-party motors, for example), use a Sensor Module External (SME120 or SME125) or Terminal Module TM120.

NOTICE

Device failure as a result of unshielded or incorrectly routed cables to temperature sensors

Unshielded or incorrectly routed cables to temperature sensors can result in interference being coupled into the signal processing electronics from the power side. This can result in significant disturbance of all signals (fault messages) up to failure of individual components (destruction of the devices).

- Only use shielded cables as temperature sensor cables.
- If temperature sensor cables are routed together with the motor cable, use separately shielded cables twisted in pairs.
- Connect the cable shield to ground potential through a large surface area.
- Recommendation: Use the appropriate MOTION-CONNECT cables.

NOTICE**Damage to the motor in the event of incorrectly connected KTY temperature sensor at terminals X41:3,4**

If a KTY temperature sensor is connected with incorrect polarity, it is not possible to detect when the motor overheats. Overheating can cause damage to the motor.

- Connect a KTY temperature sensor with the correct polarity.

NOTICE**Damage to the electrical cabinet in the event of incorrectly connected KTY temperature sensor at terminals X41:5,6**

If a KTY temperature sensor is connected with incorrect polarity, it is not possible to detect when the electrical cabinet overheats. Overheating can damage the electrical cabinet.

- Connect a KTY temperature sensor with the correct polarity.

Note

The temperature sensor connection at terminals X41:3,4 can be used for motors that are equipped with a KTY84-1C130, PT100, PT1000 or PTC measuring sensor in the stator windings.

Note**Function of the EP terminals**

The function of the EP terminals is only available when Safety Integrated Basic Functions are enabled.

6.3.7 X42 terminal strip

Table 6- 5 Terminal strip X42 voltage supply for Control Unit, Sensor Module and Terminal Module

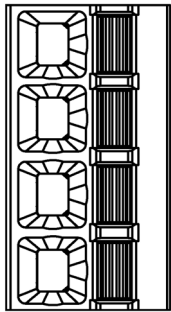
	Terminal	Function	Technical specifications
	1	P24L	Power supply for Control Unit, Sensor Module and Terminal Module (18 ... 28.8 V) Maximum load current: 3 A
	2		
	3	M	
	4		
Max. connectable cross-section: 2.5 mm ²			

Note

Connection options for terminal strip X42

The terminal strip is not intended for free 24 V DC availability (for example for supplying further line-side components), as the voltage supply of the Control Interface Module could also be overloaded and operating capability could thus be compromised.

6.3.8 X46 Brake control and monitoring

Table 6- 6 Terminal strip X46 brake control and monitoring

	Terminal	Function	Technical specifications
	1	BR output +	Brake connection Supply voltage: 24 V DC Max. load current: 0.2 mA
	2	BR output -	
	3	FB input +	
	4	FB input -	
	5	NC	Reserved, do not use
	6	NC	Reserved, do not use
Max. connectable cross-section: 1.5 mm ² The terminal strip is coded at terminal 1; please use the corresponding connector from the accessory pack.			

Note

The interface is intended for connection of the Safe Brake Adapter.

 **WARNING**
Fire due to overheating when the total length of the connecting cables is exceeded

Excessively long connection cables on terminal strip X46 can cause components to overheat with the associated risk of fire and smoke.

- Limit the length of the connecting cables to a maximum of 10 m.
- Do not route the connection cable outside the control cabinet or control cabinet group.

6.3.9 X47 contactor feedback signal

Table 6- 7 Terminal strip X47, contactor feedback signal

	Terminal	Signal name	Technical specifications
	1	VL_R	Precharging contactor feedback signal
	2	M	Supply voltage: 24 V DC Max. load current: 10 mA
	3	HS_R	Main contactor feedback signal
	4	M	Supply voltage: 24 V DC Max. load current: 10 mA
	5	NC	Reserved, do not use
	6	NC	Reserved, do not use

Max. connectable cross-section: 1.5 mm²
 The terminal strip is coded at terminal 3; please use the corresponding connector from the accessory pack.

6.3.10 X49 terminal block

Table 6- 8 Terminal strip X49

	Terminal	Function	Technical specifications
	1	LAMPPWR	Signal power
	2	M	Supply voltage: 24 V DC Max. load current: 100 mA
	3	NC	Reserved, do not use
	4	NC	Reserved, do not use
	5	NC	Reserved, do not use
	6	NC	Reserved, do not use

Max. connectable cross-section: 1.5 mm²
The terminal strip is coded at terminal 6; please use the corresponding connector from the accessory pack.

6.3.11 DRIVE-CLiQ interfaces X400, X401, X402

Table 6- 9 DRIVE-CLiQ interfaces X400, X401, X402

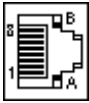
	PIN	Signal name	Technical specifications
	1	TXP	Transmit data +
	2	TXN	Transmit data -
	3	RXP	Receive data +
	4	Reserved, do not use	
	5	Reserved, do not use	
	6	RXN	Receive data -
	7	Reserved, do not use	
	8	Reserved, do not use	
	A	+ (24 V)	24 V power supply
	B	M (0 V)	Electronics ground

Blanking plate for DRIVE-CLiQ interfaces (50 pcs.) Article number: 6SL3066-4CA00-0AA0

6.3.12 Meaning of the LEDs on the Motor Module

Table 6- 10 Meaning of the "READY" and "DC LINK" LEDs on the Motor Module

LED state		Description
READY	DC LINK	
Off	Off	The electronics power supply is missing or out of tolerance.
Green	--- ¹⁾	The component is ready for operation and cyclic DRIVE-CLiQ communication is taking place.
	Orange	The component is ready for operation and cyclic DRIVE-CLiQ communication is taking place. The DC-link voltage is present.
	Red	The component is ready for operation and cyclic DRIVE-CLiQ communication is taking place. The DC link voltage lies outside the permitted tolerance range.
Orange	Orange	DRIVE-CLiQ communication is being established.
Red	--- ¹⁾	This component has at least one fault. Remark: The LED is activated irrespective of whether the corresponding messages have been reconfigured.
Flashing light 0.5 Hz: green/red	--- ¹⁾	Firmware is being downloaded.
Flashing light 2 Hz: green/red	--- ¹⁾	Firmware download is complete. Waiting for POWER ON.
Flashing light 2 Hz: green/orange or red/orange	--- ¹⁾	Detection of the components via LED is activated (p0124). Note: Both options depend on the LED status when module recognition is activated via p0124 = 1.

¹⁾ Irrespective of the status of the LED "DC LINK"

Table 6- 11 Meaning of the "PWR ON" LED on the Motor Module

LED	Color	Status	Description
PWR ON	Green	Off	DC link voltage or control voltage at -X9 too low.
		On	The component is ready for operation.
	Red	Flashing light	There is a fault. If the LED continues to flash after you have performed a POWER ON, please contact your Siemens service center.



WARNING

Electric shock when live parts of the DC link are touched

Hazardous DC link voltages may be present at any time regardless of the status of the "DC LINK" LED. This means that when live parts are touched, this can result in death or serious injury.

- Observe the warning information on the component.

6.4 Dimension drawing

Dimension drawing, FS4

The mandatory cooling clearances are indicated by the dotted line.

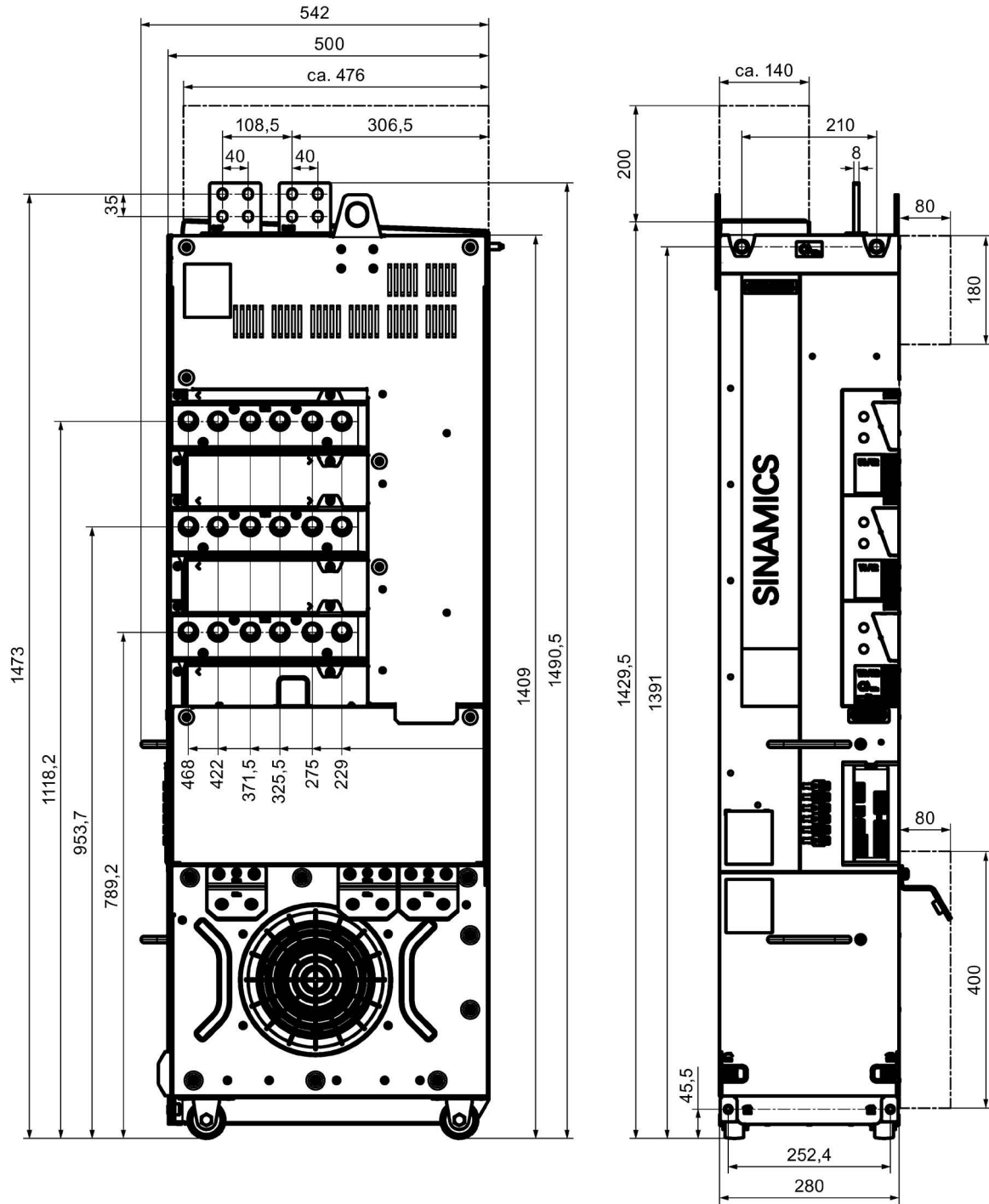

Figure 6-4 Dimension drawing, Motor Module Chassis-2 format, frame size FS4. Side view, front view

6.5 Installation

The Motor Module is fixed using 2 bolts at the upper side of the device, which are bolted into the rear panel of the electrical cabinet.

The Motor Module is then fixed to the base of the electrical cabinet using the mounting bracket.

Attaching the mounting bracket

Attach the mounting bracket at the intended position at the Motor Module.

First screw the mounting bracket to the base of the electrical cabinet, and then to the Motor Module.

When mounting, ensure that no additional pressure is applied to the rollers of the Motor Module by observing the positions of the elongated holes (11 mm x 15 mm).

Tighten the screws with a torque of 50 Nm.

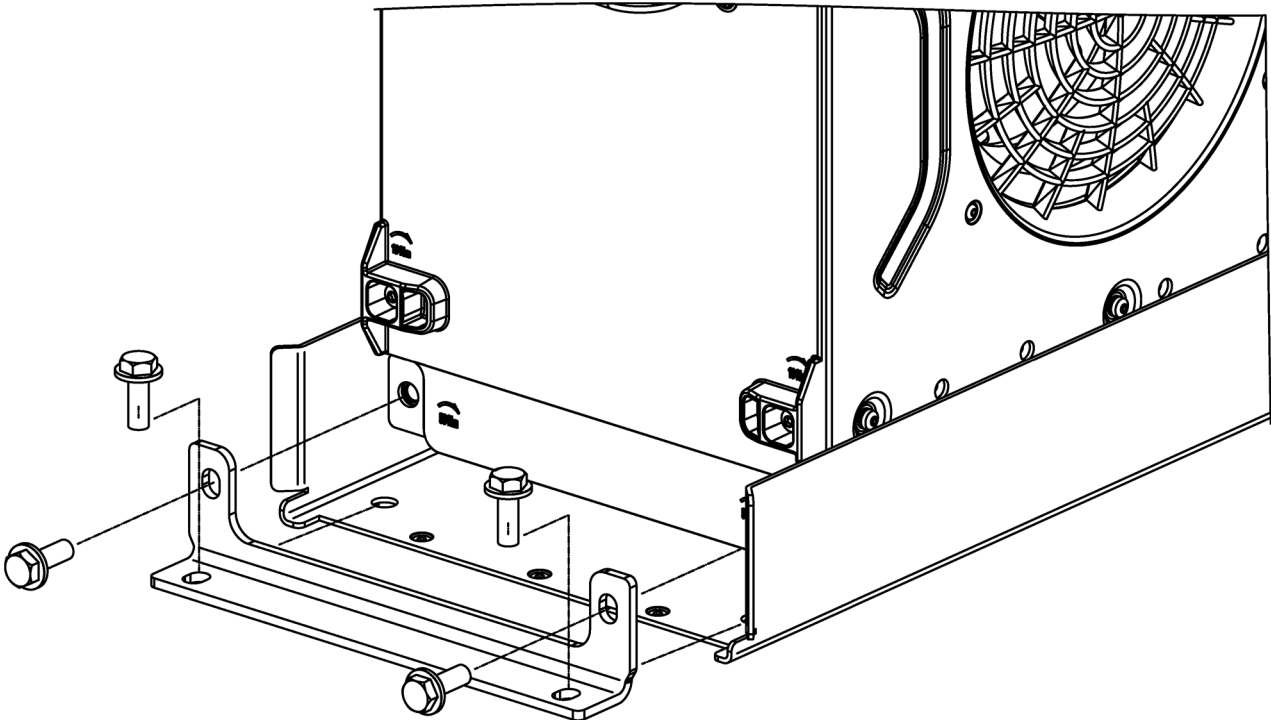

Figure 6-5 Attaching the mounting bracket

6.6 Electrical connection

Attaching the PE connections

The 3 PE connections must be attached before installing the Motor Module. The connecting busbars are included in the accessory pack.

Attach each PE connection at the Motor Module using 2 screws, torque 13 Nm.

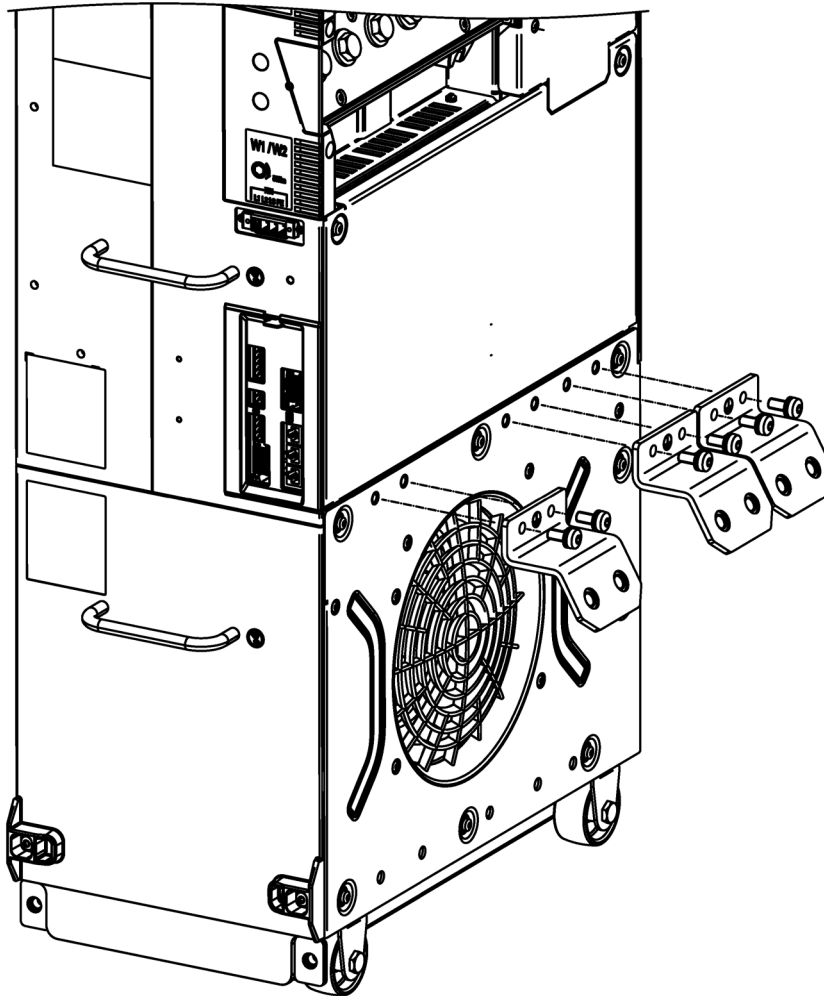

Figure 6-6 Attaching the PE connections

Attaching the PE connections

The shield connections are used to connect the shields of the shielded signal cables to the Motor Module.

Attach the support plate for the shield connections at the intended position. You can break off individual parts from the 6-part support plate corresponding to your specific requirements, torque 3 Nm.

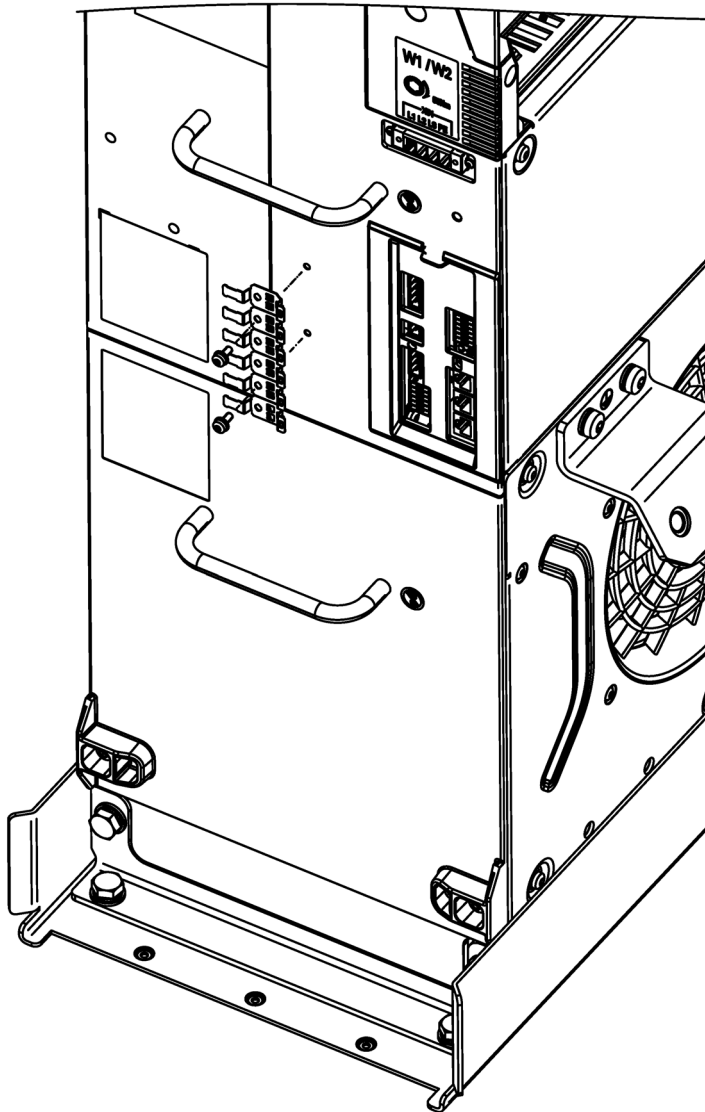
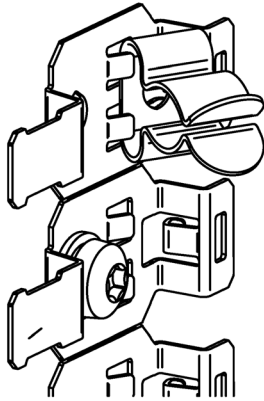

Figure 6-7 Attaching the PE connections

The accessory pack of the Motor Module includes 3 shield clamps for cable diameters 3 ...6 mm and 6 ...8 mm.

Use the appropriate shield clips corresponding to the cables to be shielded



Attach shield clip

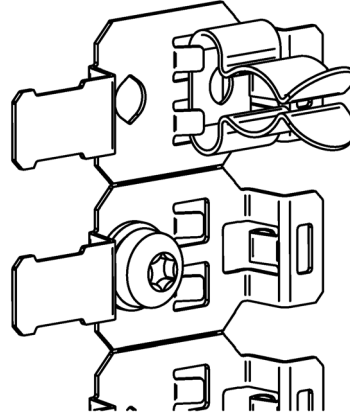

Snap in shield clip

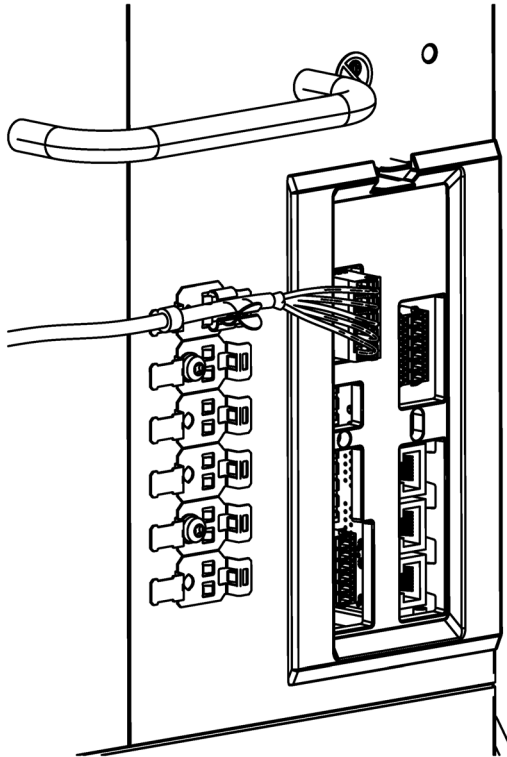

Figure 6-8 Installed signal cable with strain relief and shielding

6.7 Technical data

6.7.1 Motor Modules, 510 ... 720 V DC (line voltage 3 AC 380 ... 480 V)

Table 6- 12 Technical data, Motor Modules Chassis-2, 510 ... 720 V DC (line voltage 3 AC 380 ... 480 V)

Article number	6SL3321-	1TE41-0AA0	1TE41-1AA0	1TE41-2AA0	
Output current					
- Rated current I_{NA}	A	975	1075	1200	
- Base load current I_L	A	910	1000	1145	
- Base load current I_H	A	800	890	1000	
- Max. output current I_{max}	A	1365	1505	1710	
Type rating					
- Based on I_L (50 Hz 400 V) ¹⁾	kW	500	560	630	
- Based on I_H (50 Hz 400 V) ¹⁾	kW	450	500	560	
- Based on I_L (60 Hz 460 V) ²⁾	HP	750	850	950	
- Based on I_H (60 Hz 460 V) ²⁾	HP	650	750	850	
DC link current					
Rated current I_{NDC}	A	1170	1290	1440	
Supply voltages		510 ... 720			
- DC-link voltage	V_{DC}	24 (20.4 ... 28.8)			
- Electronic power supply	V_{DC}	0 ... 0.72 x DC-link voltage			
- Output voltage	V_{ACrms}	0 ... 0.72 x DC-link voltage			
Rated pulse frequency	kHz	2.5	2.5	2.5	
- Max. pulse frequency without derating	kHz	2.5	2.5	2.5	
- Max. pulse frequency with derating	kHz	8	8	8	
Max. ambient temperature					
- Without derating	°C	45	45	45	
- With derating	°C	60	60	60	
DC-link capacitance	µF	25900	25900	25900	
Current consumption					
- Electronics current consumption (24 V DC)	A	1.3	1.3	1.3	
- Fan supply, at 3 AC 400 V, 50/60 Hz	A	1.8 / 1.8	1.8 / 1.8	1.8 / 1.8	
Power loss, max. ³⁾					
- at 50 Hz 400 V	kW	8.7	9.5	10.4	
- at 60 Hz 460 V	kW	9.0	9.8	10.8	
Cooling air requirement	m ³ /s	0.64	0.64	0.64	
Sound pressure level					
L_{pA} (1 m) at 50/60 Hz	dB(A)	72.5	72.5	72.5	
Connections					
- DC link connection		4 x M12	4 x M12	4 x M12	
- Motor connection		6 x M12	6 x M12	6 x M12	
- PE connection		6 x M12	6 x M12	6 x M12	
Max. conductor cross-sections					
- DC link connection (DCP, DCN)		Busbar	Busbar	Busbar	
- Motor connection (U2, V2, W2)	mm ²	6 x 240	6 x 240	6 x 240	
- PE connection	mm ²	6 x 240	6 x 240	6 x 240	

6.7 Technical data

Article number	6SL3321-	1TE41-0AA0	1TE41-1AA0	1TE41-2AA0	
Max. motor cable length					
- Shielded	m	300	300	300	
- Unshielded	m	450	450	450	
Degree of protection		IP00	IP00	IP00	
Dimensions					
- Width	mm	280	280	280	
- Height	mm	1430	1430	1430	
- Depth	mm	535	535	535	
Frame size		FS4	FS4	FS4	
Weight	kg	162	162	162	
Recommended fuse acc. to IEC		3NE3336	3NE3337-8	3NE3338-8	
- Number per phase (connected in parallel)		2 ⁵⁾	2 ⁵⁾	2 ⁵⁾	
- Rated current	A	630	710	800	
- Frame size acc. to IEC 60269		2	2	2	
Recommended fuse according to UL ⁴⁾					
Type 3NB1/3NB2		3NB2355-4KK16	3NB2355-4KK16	3NB2357-4KK16	
- rated current	A	1400	1400	1600	

- 1) Rated power of a typical 6-pole standard induction motor based on I_L or I_H at 3 AC 400 V 50 Hz.
- 2) Rated power of a typical 6-pole standard induction motor based on I_L or I_H at 3 AC 460 V 60 Hz.
- 3) The specified power loss is the maximum value for a 100% utilization level. The value in normal operation is lower.
- 4) To achieve a UL-approved system, it is absolutely essential to use the fuse types specified in the table.
- 5) When using fuses connected in parallel in each phase, if one fuse ruptures, then all of the fuses must be replaced.

6.7.2 Overload capability

The Motor Modules have an overload reserve e.g. to handle breakaway torques.

In the case of drives with overload requirements, the appropriate base-load current must, therefore, be used as a basis for the required load.

The overloads apply under the precondition that the Motor Module is operated with its base load current before and after the overload; this is based on a duty cycle of 300 s (low overload, high overload) – or 60 s (S6 duty cycle).

Another precondition is that the Motor Module is operated at its factory-set pulse frequency at output frequencies >10 Hz.

For additional information on the overload capability, see the Low Voltage Configuration Manual.

Low overload

The base load current for low overload (I_L) is based on a load duty cycle of 110% for 60 s.

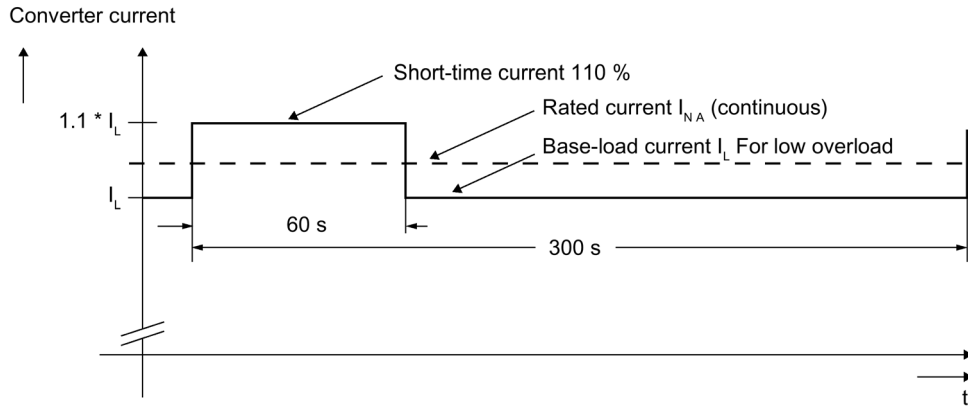

Figure 6-9 Low overload

High overload

The base load current for a high overload I_H is based on a duty cycle of 150% for 60 s.

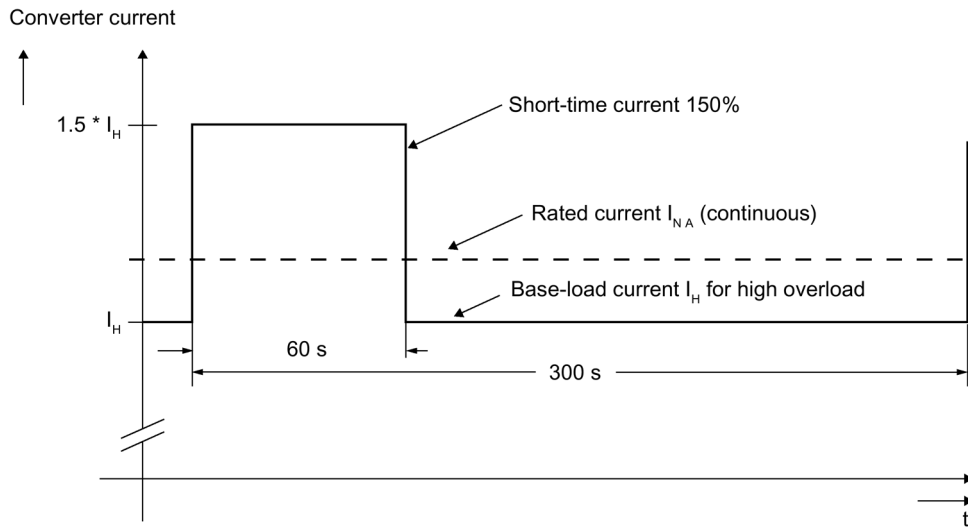

Figure 6-10 High overload

S6 duty cycle

The base load current for duty cycle I_{S6} is based on a duty cycle of 200% for 6 s.

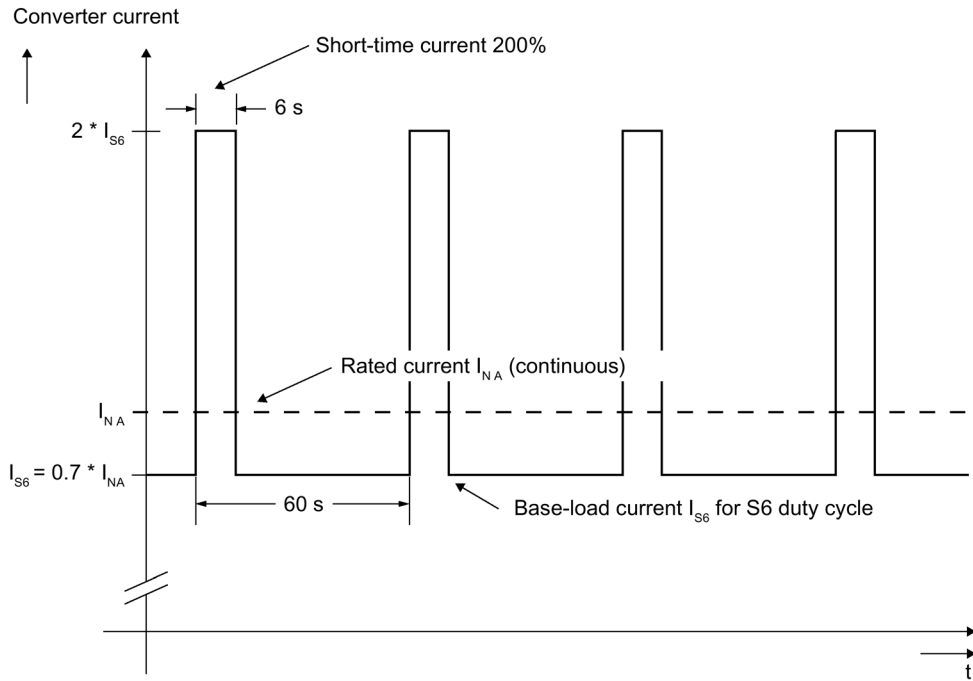

Figure 6-11 S6 duty cycle with initial load with a duty cycle duration of 60 s

6.7.3 Current de-rating depending on the pulse frequency

When the pulse frequency is increased, the derating factor of the output current must be taken into account. This derating factor must be applied to the currents specified in the technical data for Motor Modules.

Table 6- 13 Derating factor of the output current as a function of the pulse frequency for devices with a rated pulse frequency of 2.5 kHz

Article No.	Type rating	Output current at 2.5 kHz	Derating factor at the pulse frequency			
			4 kHz	5 kHz	7.5 kHz	8 kHz
6SL3321-...	[kW]	[A]				
Connection voltage 510 ... 720 V DC (line voltage 3 AC 380 ... 480 V)						
1TE41-0AA0	500	975	78%	67%	48%	45%
1TE41-1AA0	560	1075	78%	67%	48%	45%
1TE41-2AA0	630	1200	78%	67%	48%	45%

Note

Derating factors for pulse frequencies in the range between two fixed values

For pulse frequencies in the range between the specified fixed values, the relevant derating factors can be determined by linear interpolation.

Maximum output frequencies achieved by increasing the pulse frequency

The adjustable pulse frequencies – and therefore the output frequencies that can be achieved with the factory-set current controller clock cycles – are listed below.

Current controller clock cycle T_i	Adjustable pulse frequencies f_p	Maximum achievable output frequency f_A		
		V/f operating mode	Vector operating mode	Servo mode
400 μ s	2.50 kHz	208 Hz	208 Hz	-
	5.00 kHz	416 Hz	300 Hz	-
	7.50 kHz	550 Hz ¹⁾	300 Hz	-

¹⁾ With the "High output frequencies" license, which can be ordered as option J01 on the CompactFlash card for SINAMICS S120, the maximum output frequency is increased up to 650 Hz.

Refer to the Low Voltage Configuration Manual for current controller clock cycles deviating from the factory setting.

6.7.4 Parallel connection of Motor Modules

The following rules must be observed when connecting Motor Modules Chassis-2 in parallel:

- Up to 6 identical Motor Modules can be connected in parallel.
- A common Control Unit is required whenever the modules are connected in parallel.
- The motor supply cables must have the same length (symmetrical design).
- Power must be supplied to the Motor Modules from a common DC link.
- For motors with a single winding system, supply cables with a minimum length or motor reactors must be used. The cable lengths are listed in the following tables.
- A derating factor of 5% must be taken into consideration, regardless of the number of Motor Modules connected in parallel.

Note

Mixed operation is not possible

It is only possible to connect identical power units in parallel if all power units have the same hardware version. It is not permissible to operate a Motor Module (Article number 6SL3320-xxxxx-xAA3) together with a Motor Module Chassis-2 (Article number 6SL3321-xxxxx-xAA0).

Minimum cable lengths for parallel connection and connection to a motor with a single-winding system

Note

Minimum cable lengths

The minimum cable lengths specified in the tables below must be observed when two or more Motor Modules are connected in parallel and there is a connection to a motor with a single-winding system. If the cable length required for the application cannot be achieved, a motor reactor must be provided.

Table 6- 14 Motor Modules Chassis-2, 510 ... 720 V DC (line voltage 3 AC 380 ... 480 V)

Article number	Type rating [kW]	Output current [A]	Minimum cable length [m]
6SL3321-1TE41-0AA0	500	975	8
6SL3321-1TE41-1AA0	560	1075	8
6SL3321-1TE41-2AA0	630	1200	8

DC link components

7.1 Braking Module

7.1.1 Description

A Braking Module and an external braking resistor are required to bring drives to a controlled standstill in the event of a power failure (e.g. emergency retraction or EMERGENCY STOP category 1) or limit the DC-link voltage if the generator is operated for a short period of time, for example because there is no regenerative feedback capability into the supply network when a Basic Line Module is used. The Braking Module contains the power electronics and the associated control.

During operation the DC-link energy is converted into heat loss in an external braking resistor outside of the control cabinet. Braking Modules function autonomously. Parallel operation of several braking modules is possible. In this case, each Braking Module must have its own braking resistor.

Up to 3 slots are available depending on the size of the Line Module or Motor Module:

Frame sizes FB, GB, GD, FX, GX:	1 mounting location
Frame size HX:	2 mounting locations
Frame size JX:	3 mounting locations
Frame size FS4:	Installation not possible

Note

No installation in Motor Modules Chassis-2

It is not permissible to install the Braking Modules in a Motor Module Chassis-2.

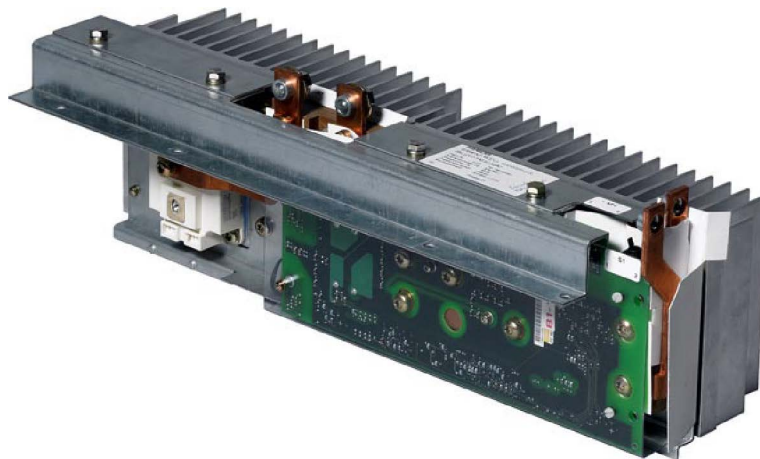

Figure 7-1 Braking Module

Layout

The Braking Module in the chassis format is inserted in a mounting location inside the Line Module or Motor Module, whose fan force cools it. The supply voltage for the electronics is drawn from the DC link. The Braking Module is connected to the DC link by means of the busbar sets and flexible cables, which are supplied as standard.

The activation threshold of the Braking Module can be adjusted by means of a DIP switch. The braking power values specified in the technical specifications apply to the upper activation threshold.

The Braking Module has as standard, the following interfaces:

- The DC link is connected through busbars and flexible cables
- Connecting terminal for external braking resistor
- 1 digital input (inhibit Braking Module with high signal / acknowledge error with negative edge high-low)
- 1 digital output (Braking Module inhibited)
- 1 DIP switch for adjusting the activation threshold

Note

Installing a Braking Module of frame size GX in a Basic Line Module of frame size GB or GD

To install a frame size GX Braking Module in a frame size GB or GD Basic Line Module a cable harness set is required, which is available under Article number 6SL3366-2NG00-0AA0.

7.1.2 Safety information

WARNING

Not observing fundamental safety instructions and residual risks

Not observing fundamental safety instructions and residual risks listed in Chapter 1 can result in accidents with severe injuries or death.

- Comply with the fundamental safety instructions.
- When assessing the risk, take into account remaining risks.

WARNING

Fire and device damage as a result of ground fault/short-circuit

Inadequate installation of the cables to the braking resistor can result in a ground fault/short-circuit and place persons at risk as a result of the associated smoke and fire.

- Comply with local installation regulations that enable this fault to be ruled out.
- Protect the cables from mechanical damage.
- In addition, apply one of the following measures:
 - Use cables with double insulation.
 - Maintain adequate clearance, e.g. by using spacers.
 - Route the cables in separate cable ducts or pipes.

WARNING

Fire due to overheating when the total length of the connecting cables is exceeded

Excessively long Braking Module connection cables can cause components to overheat with the associated risk of fire and smoke.

- The Braking Module connecting cables may not be longer than 100 m.

NOTICE

Damage through the use of non-released braking resistors

Braking resistors can be damaged when using braking resistors other than those specified in this Manual.

- Only use braking resistors released by Siemens.

7.1.3 Interface description

7.1.3.1 Braking Module for frame sizes FX, FB

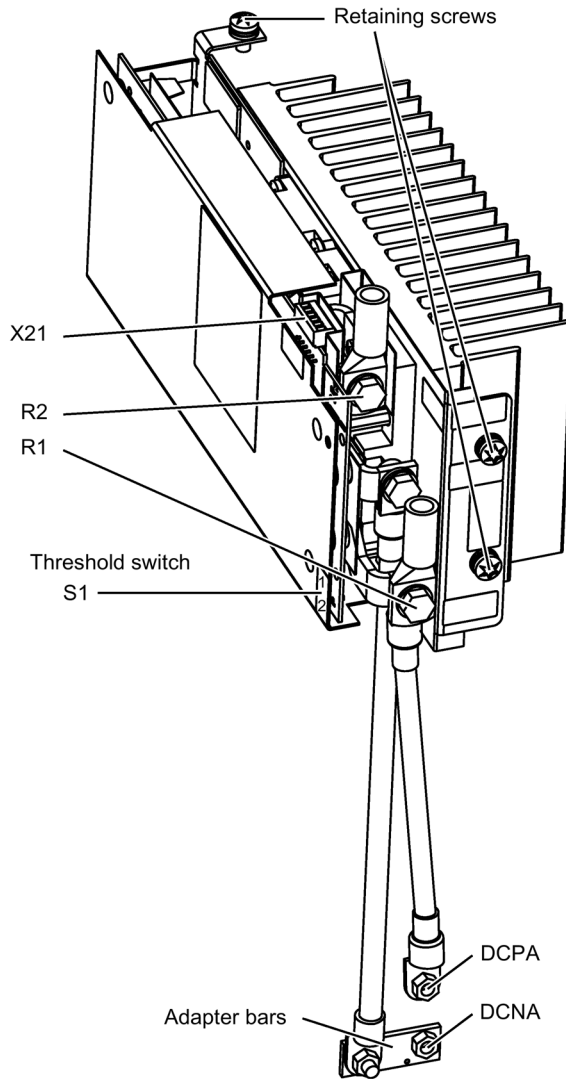

Figure 7-2 Braking Module for Active Line Module / Motor Module, frame size FX and for Basic Line Module, frame size FB

Note

Common connection for the R1 and DCPA

With this Braking Module, the R1 and DCPA interfaces use the same connection.

7.1.3.2 Braking Module for frame sizes GX, GB, GD

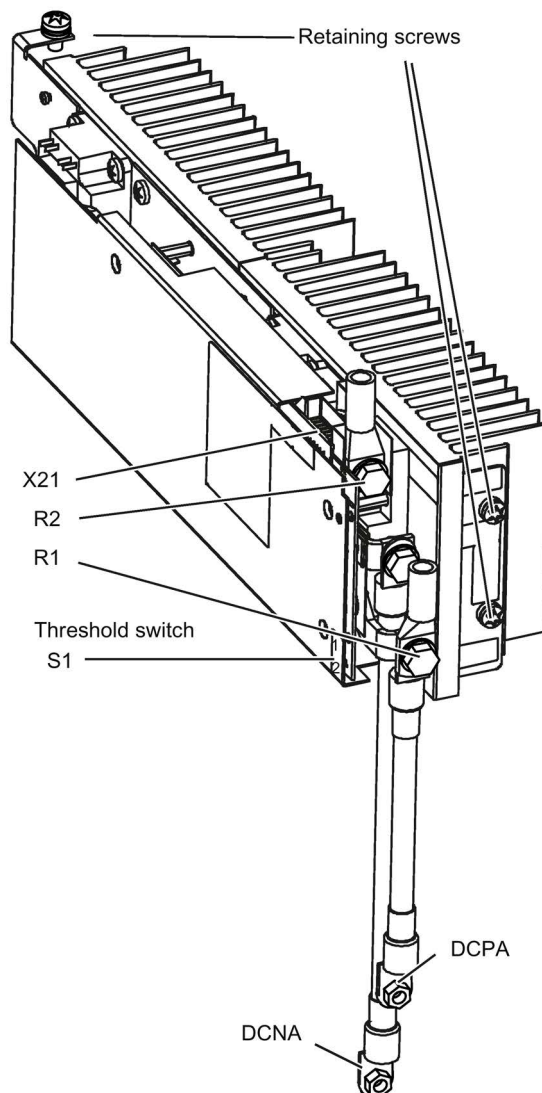

Figure 7-3 Braking Module for Smart Line Module / Active Line Module / Motor Module, frame size GX and for Basic Line Module, frame size GB, GD

Note

Common connection for the R1 and DCPA

With this Braking Module, the R1 and DCPA interfaces use the same connection.

7.1.3.3 Braking Module for frame sizes HX, JX

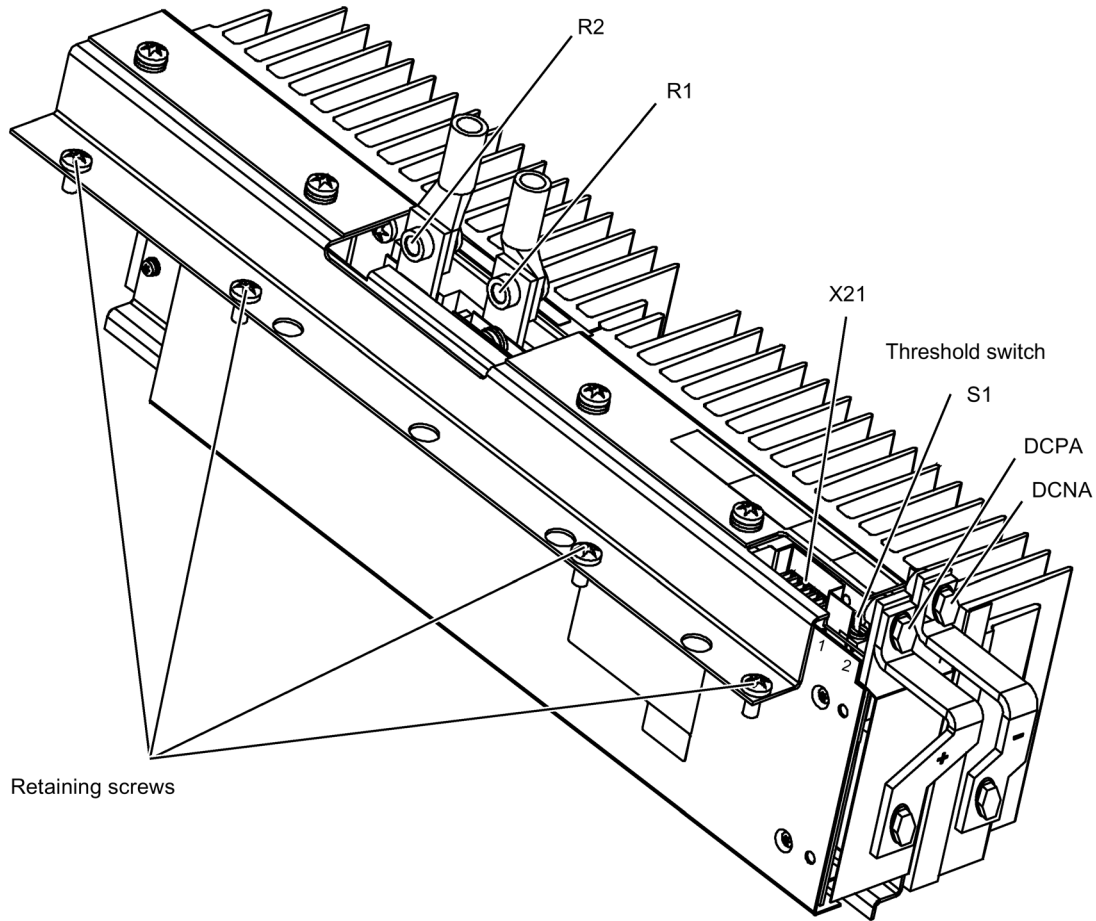

Figure 7-4 Braking Module for Smart Line Module / Active Line Module / Motor Module, frame sizes HX / JX

7.1.3.4 Connection example

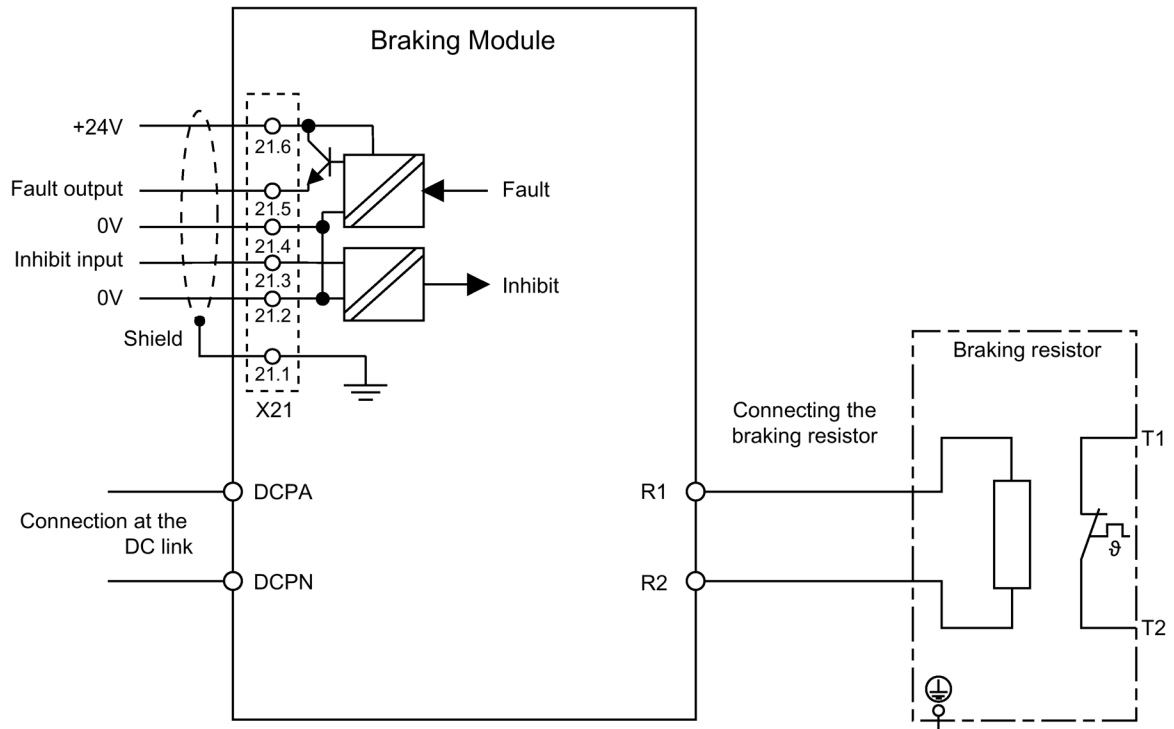

Figure 7-5 Connection example for Braking Module

7.1.3.5 Braking resistor connection

Table 7- 1 Braking resistor connection

Terminal	Designation
R1	Braking resistor connection R+
R2	Braking resistor connection R-
Recommended conductor cross-sections: for 25/125 kW: 35 mm ² , for 50/250 kW: 50 mm ²	

7.1.3.6 X21 digital inputs/outputs

Table 7- 2 X21 terminal strip

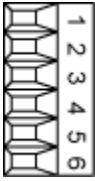
	Terminal	Designation ¹⁾	Technical specifications
	1	Shield	Shield connection for terminals 2 ... 6
	2	0 V	High level: +15 ... 30 V Current drawn: 2 ... 15 mA Low level: -3 ... 5 V
	3	DI inhibit input	
	4	0 V	High signal: No fault Low signal: Fault present Voltage: 24 V DC Load current: 0.5 ... 0.6 A
	5	DO fault output	
	6	+24 V	Voltage: +18 ... 30 V Typical current consumption (intrinsic current consumption): 10 mA at 24 V DC
Max. connectable cross-section 1.5 mm ²			

1) DI: Digital input; DO: Digital output

Note

Position of the terminals

The position of the individual terminals of terminal strip X21 on the Braking Module are as follows when the module is installed: Terminal "1" is at the back, terminal "6" is at the front.

Note

Signal characteristics of terminal X21.3

Applying a high signal to terminal X21.3 inhibits the Braking Module. On a falling edge, pending error signals are acknowledged.

Note

The Braking Module requires a DC link voltage so that the "No fault" message can be issued correctly.

Note

Notes on setting

You will find setting instructions for wiring the signals in the SINAMICS S120 Function Manual.

7.1.3.7 S1 Threshold switch

The response threshold at which the Braking Module is activated and the DC-link voltage generated during braking are specified in the following table.



 WARNING
Electric shock when the threshold switch switches
Operating the threshold switch when a voltage is present can cause death or serious injury.
<ul style="list-style-type: none"> • Only use the threshold switch when the Basic Line, Smart Line, Active Line, or Motor Module are switched off and the DC link capacitors are discharged.

Table 7- 3 Response thresholds of the Braking Modules

Voltage	Response threshold	Switch position	Remark
3 AC 380 ... 480 V	673 V	1	774 V is the default factory setting. For line voltages of between 3 AC 380 V and 400 V, the response threshold can be set to 673 V to reduce the voltage stress on the motor and converter. This does, however, reduce the possible braking power with the square of the voltage $(673/774)^2 = 0.75$. The maximum possible braking power is therefore 75%.
	774 V	2	
3 AC 500 ... 600 V	841 V	1	967 V is the default factory setting. With a supply voltage of 3 AC 500 V, the response threshold can be set to 841 V to reduce the voltage stress on the motor and converter. This does, however, reduce the possible braking power with the square of the voltage $(841/967)^2 = 0.75$. The maximum possible braking power is therefore 75%.
	967 V	2	
3 AC 660 ... 690 V	1070 V	1	1158 V is the default factory setting. With a supply voltage of 3 AC 660 V, the response threshold can be set to 1070 V to reduce the voltage stress on the motor and converter. This does, however, reduce the possible braking power with the square of the voltage $(1070/1158)^2 = 0.85$. The maximum possible braking power is therefore 85%.
	1158 V	2	

Note

Positions of the threshold switches

The switch positions of the threshold switches of the Braking Modules are positioned on the panel as follows:

- Braking Modules for frame sizes FX, FB, GX, GB, GD: Position "1" is at the top; position "2" is at the bottom
- Braking Modules for frame sizes HX and JX: Position "1" is at the back; position "2" is at the front

Note

"Overvoltage" fault

Even when the response threshold is set to a low value, the DC-link voltage can still reach the maximum voltage value (hardware shutdown threshold), thus triggering the "Overvoltage" fault. This can occur, for example, in cases where there is too much regenerative energy for the available braking power.

To prevent the DC-link voltage from exceeding the threshold, the Vdc-max controller must be enabled (p1240) and the device supply voltage set accordingly (p0210).

7.1.4 Installation

7.1.4.1 Installing the Braking Module in an Active Line Module / Motor Module, frame size FX

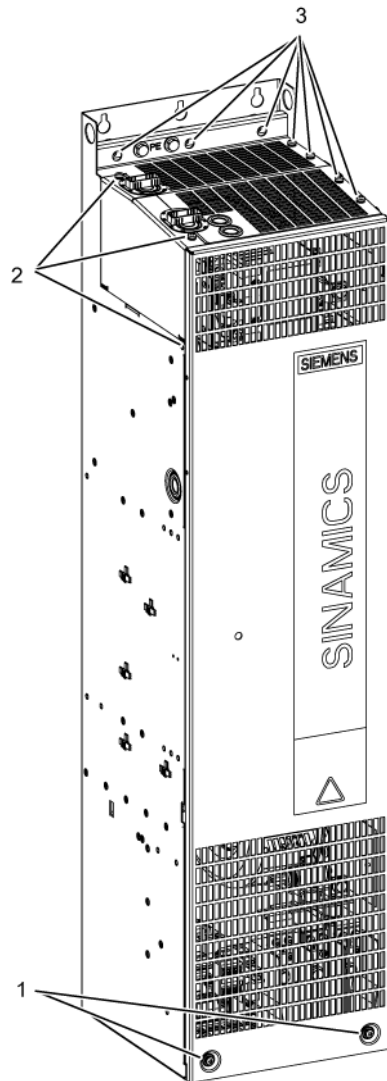

Figure 7-6 Installing the Braking Module in an Active Line Module / Motor Module, frame size FX – Steps 1 - 3

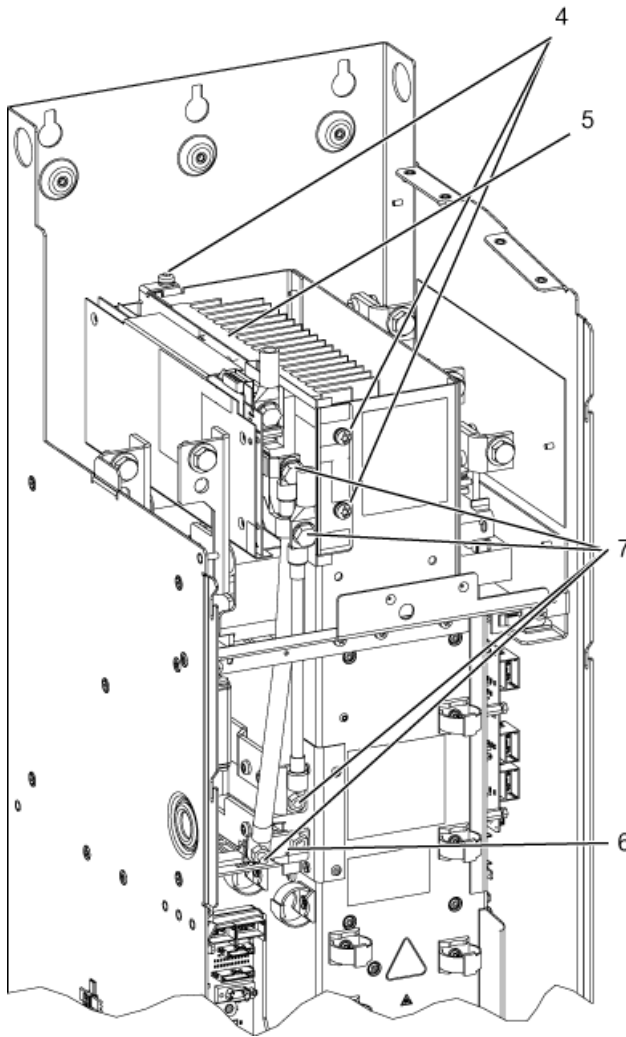

Figure 7-7 Installing the Braking Module in an Active Line Module / Motor Module, frame size FX – Steps 4 - 7

Installing the Braking Module

The steps for the installation procedure are numbered in accordance with the diagrams in front of them.

1. Unscrew the two M6 screws from the front cover and lift off the cover.
2. Unscrew the two screws from the upper cover plate.
Loosen the M6 nut on the left
Remove the left cover
3. Unscrew the four screws from the upper cover plate.
Unscrew the three screws from the rear cut-out sections
Remove the top covers.
4. Unscrew the three screws of the blanking plate.
Remove the plate.
5. Insert the Braking Module where the cover used to be and secure it using the three screws (from step 4).
6. Attach the adapter bar to the DCNA using a nut, so that the busbar cannot be twisted.
For this purpose, a small bolt is attached to the adapter bar, which must be located on the lower side of the DCNA connection.
7. Secure the connecting cable to the DC link with two screws (Braking Module connection) and two nuts (DC-link connection).

Carry out the subsequent steps in reverse order from steps 1 - 3.

An opening above the connections for the braking resistor (R1, R2) is provided in the cover for connecting the cable to the braking resistor.

Note

Pay attention to the tightening torques

The tightening torques specified in the table "Tightening torques for screw connections" must be observed.

7.1.4.2 Installing the Braking Module in a Smart Line Module / Active Line Module / Motor Module, frame size GX

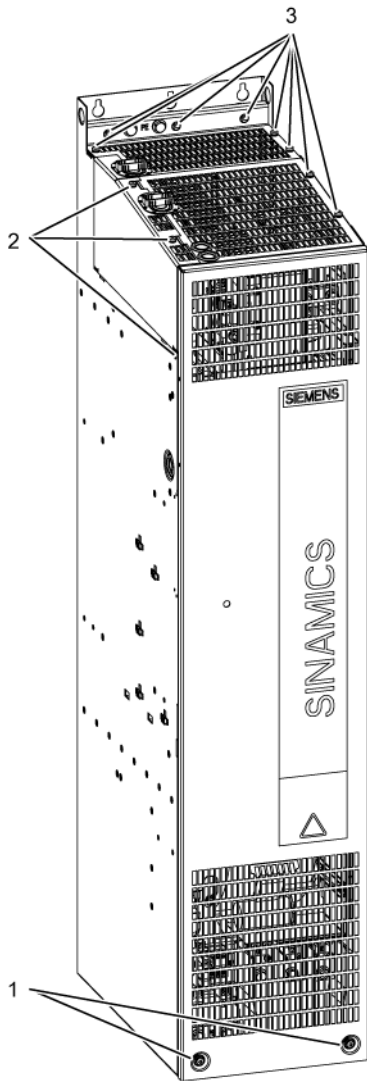

Figure 7-8 Installing the Braking Module in a Smart Line Module / Active Line Module / Motor Module, frame size GX – Steps 1 - 3

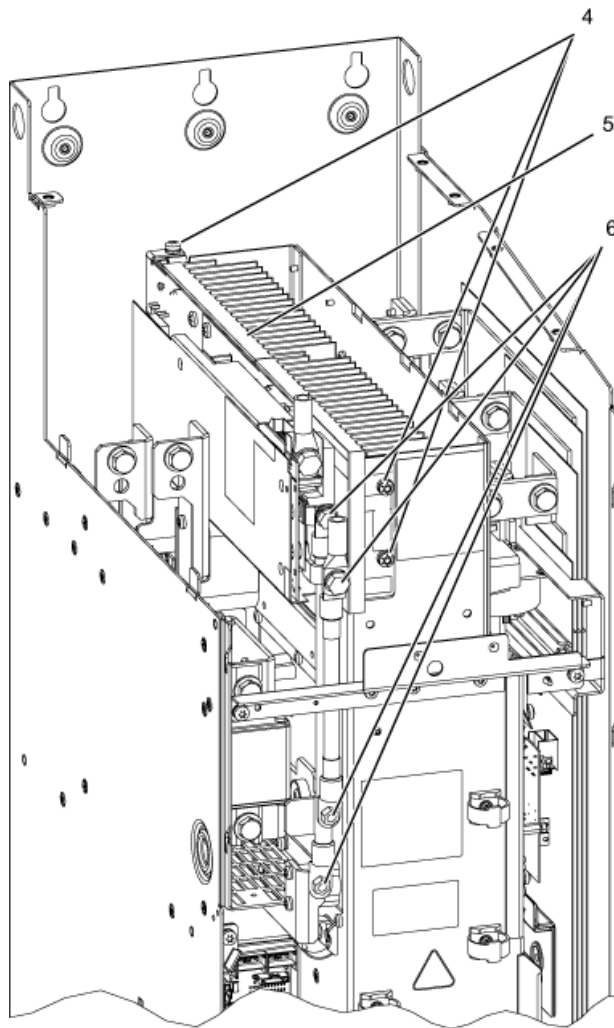

Figure 7-9 Installing the Braking Module in a Smart Line Module / Active Line Module / Motor Module, frame size GX – Steps 4 - 6

Installing the Braking Module

The steps for the installation procedure are numbered in accordance with the diagrams in front of them.

1. Unscrew the two M6 screws from the front cover and lift off the cover.

2. Unscrew the two screws from the upper cover plate.

Loosen the M6 nut on the left.

Remove the left cover

3. Unscrew the four screws from the upper cover plate.

Unscrew the three screws from the rear cut-out sections.

Remove the top covers.

4. Unscrew the three screws of the blanking plate.

Remove the plate.

5. Insert the Braking Module where the cover used to be and secure it using the three screws (from step 4).

6. Secure the connecting cable to the DC link with two screws (Braking Module connection) and two nuts (DC-link connection).

Carry out the subsequent steps in reverse order from steps 1 - 3.

An opening above the connections for the braking resistor (R1, R2) is provided in the cover for connecting the cable to the braking resistor.

Note

Pay attention to the tightening torques

The tightening torques specified in the table "Tightening torques for screw connections" must be observed.

7.1.4.3 Installing the Braking Module in a Smart Line Module / Active Line Module / Motor Module, frame size HX

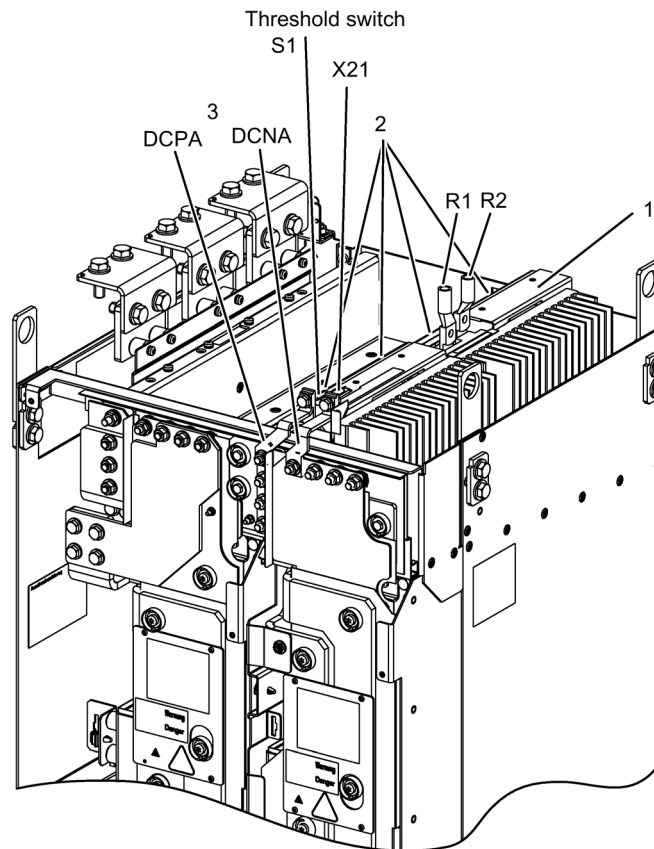

Figure 7-10 Installing the Braking Module in a Smart Line Module / Active Line Module / Motor Module, frame size HX

Installing the Braking Module

The steps for the installation procedure are numbered in accordance with the diagram.

1. Insert the Braking Module.
2. Tighten the 4 retaining screws for the Braking Module.
3. Secure the connection clip to the DC link (DCPA/DCNA) with two screws (Braking Module connection) and two nuts (DC-link connection).

Note

Pay attention to the tightening torques

The tightening torques specified in the table "Tightening torques for screw connections" must be observed.

7.1.4.4 Installing the Braking Module in a Smart Line Module / Active Line Module / Motor Module, frame size JX

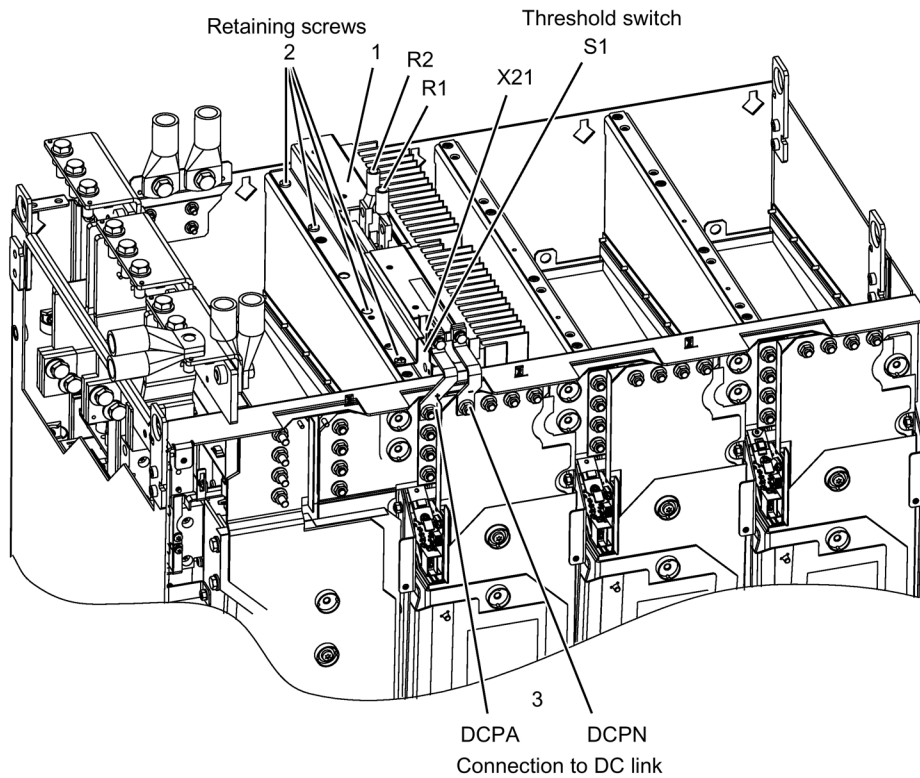

Figure 7-11 Installing the Braking Module in a Smart Line Module / Active Line Module / Motor Module, frame size JX

Installing the Braking Module

The steps for the installation procedure are numbered in accordance with the diagram.

1. Insert the Braking Module.
2. Tighten the four retaining screws for the Braking Module.
3. Secure the connection clip to the DC link (DCPA/DCNA) with two screws (Braking Module connection) and two nuts (DC-link connection).

Note

Pay attention to the tightening torques

The tightening torques specified in the table "Tightening torques for screw connections" must be observed.

7.1.4.5 Installing the Braking Module in a Basic Line Module, frame size FB

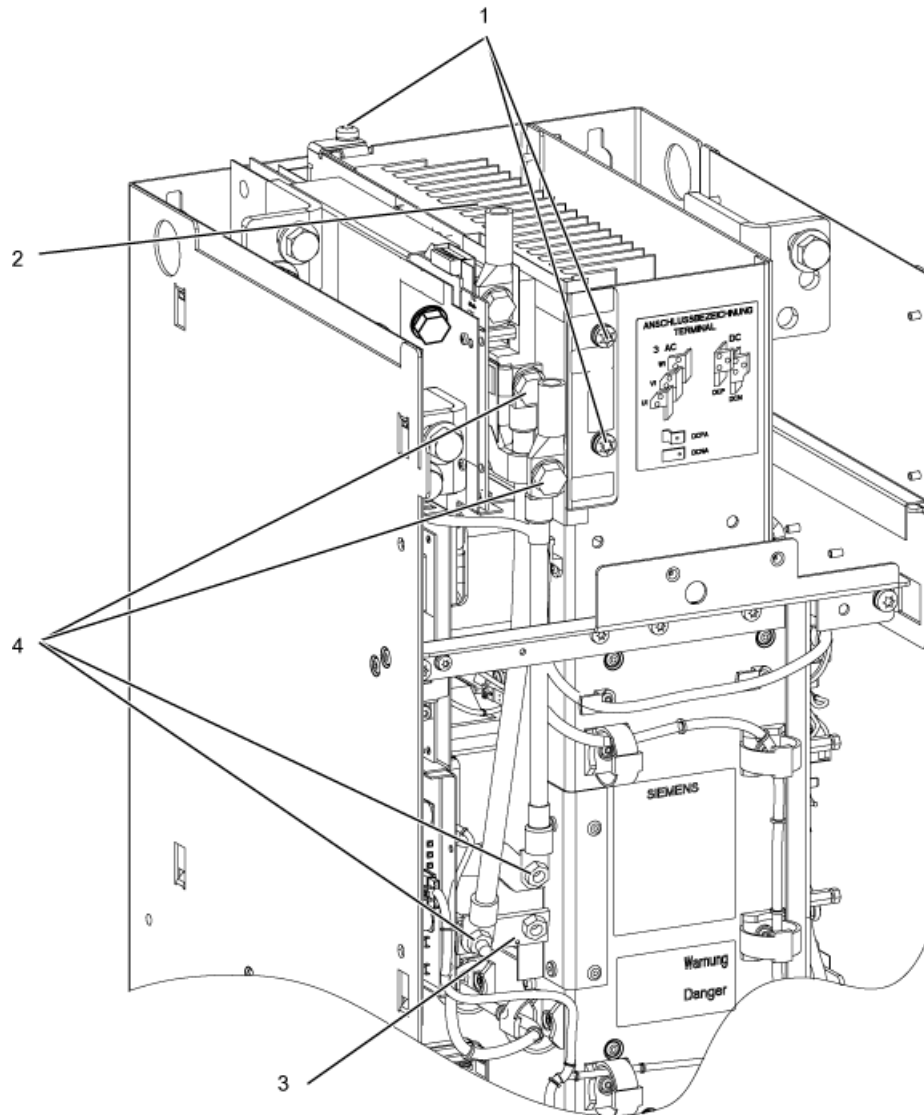

Figure 7-12 Installing the Braking Module in a Basic Line Module, frame size FB

Installing the Braking Module

The steps for the installation procedure are numbered in accordance with the diagram.

1. Unscrew the three screws of the blanking plate.

Remove the plate.

2. Insert the Braking Module where the cover used to be and secure it using the three screws (from step 1).
3. Attach the adapter bar to the DCNA using a nut, so that the busbar cannot be twisted. For this purpose, a small bolt is attached to the adapter bar, which must be located on the lower side of the DCNA connection.
4. Secure the connecting cable to the DC link with two screws (Braking Module connection) and two nuts (DC-link connection).

Note

Pay attention to the tightening torques

The tightening torques specified in the table "Tightening torques for screw connections" must be observed.

7.1.4.6 Installing the Braking Module in a Basic Line Module, frame size GB, GD

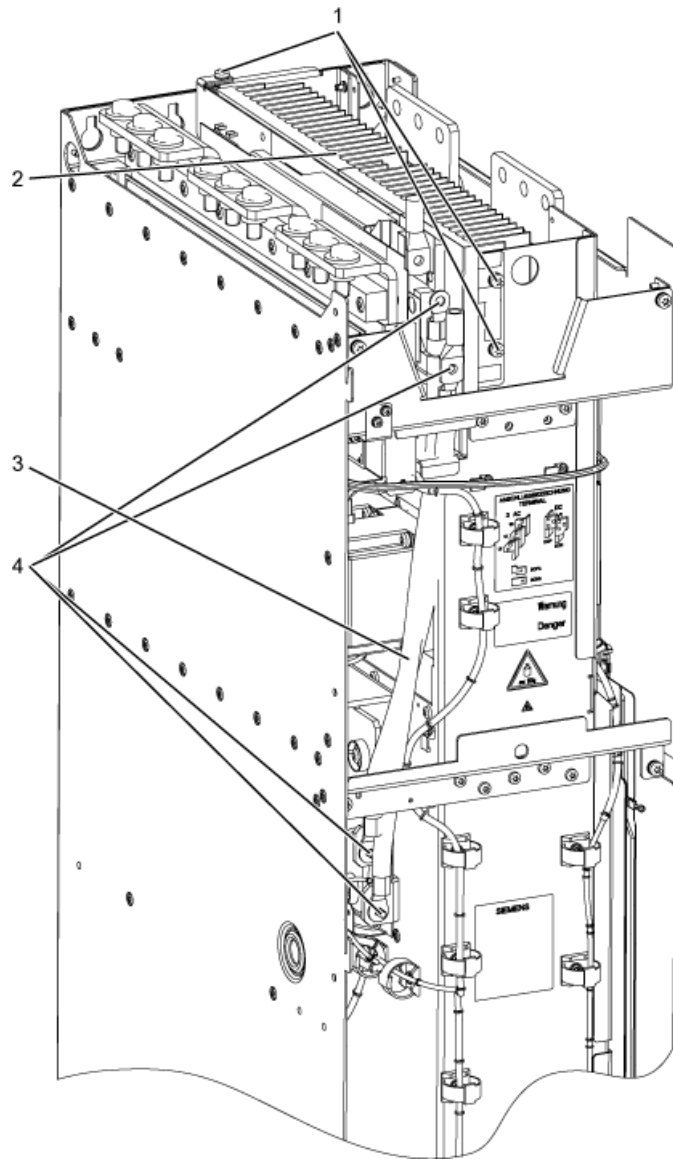

Figure 7-13 Installing the Braking Module in a Basic Line Module, frame size GB, GD

Installing the Braking Module

Note

To install a frame size GX Braking Module in a frame size GB or GD Basic Line Module a cable harness set is required, which is available under Article number 6SL3366-2NG00-0AA0.

The steps for the installation procedure are numbered in accordance with the diagram.

1. Unscrew the three screws of the blanking plate.
Remove the plate.
 2. Insert the Braking Module where the cover used to be and secure it using the three screws (from step 1).
 3. Use the connecting cable in the cable harness set (Article number 6SL3366-2NG00-0AA0).
 4. Secure the connecting cable to the DC link with two screws (Braking Module connection) and two nuts (DC-link connection).
-

Note

Pay attention to the tightening torques

The tightening torques specified in the table "Tightening torques for screw connections" must be observed.

7.1.5 Technical specifications

Table 7- 4 Technical data, Braking Modules, 3 AC 380 V ... 480 V

Braking Module 6SL3300-	1AE31-3AA0	1AE32-5AA0	1AE32-5BA0
Suitable for installation in: Smart Line Module / Active Line Module / Motor Module, frame size Basic Line Module, frame size	FX FB	GX GB, GD	HX / JX --
P _{DB} power (rated power)	25 kW	50 kW	50 kW
P ₁₅ power (peak power)	125 kW	250 kW	250 kW
P ₂₀ power	100 kW	200 kW	200 kW
P ₄₀ power	50 kW	100 kW	100 kW
Variable response thresholds	774 V (673 V)		
Digital input			
Voltage	-3 ... 30 V		
Low level (an open digital input is interpreted as "low")	-3 ... 5 V		
High level	15 ... 30 V		
Current consumption (typical at 24 V DC)	10 mA		
Max. connectable cross-section	1.5 mm ²		
Digital output (continuously short-circuit proof)			
Voltage	24 V DC		
Max. load current of the digital output	500 mA		
Max. connectable cross-section	1.5 mm ²		
R1/R2 connection	M8 screw	M8 screw	M8 screw
Max. conductor cross-section R1/R2	35 mm ²	50 mm ²	50 mm ²
Weight, approx.	3.6 kg	7.3 kg	7.5 kg

Table 7- 5 Technical data, Braking Modules, 3 AC 500 V ... 600 V

Braking Module 6SL3300-	1AF31-3AA0	1AF32-5AA0	1AF32-5BA0
Suitable for installation in: Smart Line Module / Active Line Module / Motor Module, frame size	FX	GX	HX / JX
Basic Line Module, frame size	FB	GB, GD	--
P _{DB} power (rated power)	25 kW	50 kW	50 kW
P ₁₅ power (peak power)	125 kW	250 kW	250 kW
P ₂₀ power	100 kW	200 kW	200 kW
P ₄₀ power	50 kW	100 kW	100 kW
Variable response thresholds	967 V (841 V)		
Digital input			
Voltage	-3 ... 30 V		
Low level (an open digital input is interpreted as "low")	-3 ... 5 V		
High level	15 ... 30 V		
Current consumption (typical at 24 V DC)	10 mA		
Max. connectable cross-section	1.5 mm ²		
Digital output (continuously short-circuit proof)			
Voltage	24 V DC		
Max. load current of the digital output	500 mA		
Max. connectable cross-section	1.5 mm ²		
R1/R2 connection	M8 screw	M8 screw	M8 screw
Max. conductor cross-section R1/R2	35 mm ²	50 mm ²	50 mm ²
Weight, approx.	3.6 kg	7.3 kg	7.5 kg

Table 7- 6 Technical data, Braking Modules, 3 AC 660 V ... 690 V

Braking Module 6SL3300-	1AH31-3AA0	1AH32-5AA0	1AH32-5BA0
Suitable for installation in: Smart Line Module / Active Line Module / Motor Module, frame size	FX	GX	HX / JX
Basic Line Module, frame size	FB	GB, GD	
P _{DB} power (rated power)	25 kW	50 kW	50 kW
P ₁₅ power (peak power)	125 kW	250 kW	250 kW
P ₂₀ power	100 kW	200 kW	200 kW
P ₄₀ power	50 kW	100 kW	100 kW
Variable response thresholds	1158 V (1070 V)		
Digital input			
Voltage	-3 ... 30 V		
Low level (an open digital input is interpreted as "low")	-3 ... 5 V		
High level	15 ... 30 V		
Current consumption (typical at 24 V DC)	10 mA		
Max. connectable cross-section	1.5 mm ²		
Digital output (continuously short-circuit proof)			
Voltage	24 V DC		
Max. load current of the digital output	500 mA		
Max. connectable cross-section	1.5 mm ²		
R1/R2 connection	M8 screw	M8 screw	M8 screw
Max. conductor cross-section R1/R2	35 mm ²	50 mm ²	50 mm ²
Weight, approx.	3.6 kg	7.3 kg	7.5 kg

7.2 Braking resistors

7.2.1 Description

The excess energy of the DC link is dissipated via the braking resistor.

The braking resistor is connected to a Braking Module. The braking resistor is positioned outside the cabinet or switchgear room. This enables the heat loss from the Line Modules or Motor Modules to be dissipated. This reduces the level of air conditioning required.

Resistors with rated powers of 25 kW and 50 kW are available.

Greater outputs can be implemented by connecting Braking Modules and braking resistors in parallel. In this case, the Braking Modules are installed in the air duct of the Line Modules and Motor Modules. Depending on the size of the respective module, up to three mounting locations are available.

Since the braking resistors can be used in converters with a wide voltage range, the voltage can be adjusted (for example, to reduce the voltage stress on the motor and converter) by setting the response thresholds on the Braking Module.

A thermostatic switch monitors the braking resistor for overtemperature and issues a signal on a floating contact if the limit value is exceeded.

7.2.2 Safety information

WARNING

Not observing fundamental safety instructions and residual risks

Not observing fundamental safety instructions and residual risks listed in Chapter 1 can result in accidents with severe injuries or death.

- Comply with the fundamental safety instructions.
- When assessing the risk, take into account remaining risks.

WARNING

Fire due to overheating when the total length of the connecting cables is exceeded

Excessively long Braking Module connection cables can cause components to overheat with the associated risk of fire and smoke.

- The Braking Module connecting cables may not be longer than 100 m.

WARNING

Fire due to overheating because of inadequate ventilation clearances

Inadequate ventilation clearances can cause overheating with a risk for personnel through smoke development and fire. This can also result in increased failures and reduced service lives of braking resistors.

- It is essential that you maintain a ventilation clearance of 200 mm on all sides of the component with ventilation grilles.

WARNING

Fire and device damage as a result of ground fault/short-circuit

Inadequate installation of the cables to the braking resistor can result in a ground fault/short-circuit and place persons at risk as a result of the associated smoke and fire.

- Comply with local installation regulations that enable this fault to be ruled out.
- Protect the cables from mechanical damage.
- In addition, apply one of the following measures:
 - Use cables with double insulation.
 - Maintain adequate clearance, e.g. by using spacers.
 - Lay the cables in separate cable ducts or conduits.

 WARNING
Risk of fire as a result of braking resistor thermal power loss A braking resistor which is not mounted properly can cause components to overheat with the associated risk of fire and development of smoke. <ul style="list-style-type: none">• Only mount braking resistors on a baseplate/floor.• Mount the braking resistors so that they are in the vertical position and freestanding. Sufficient space must be available for dissipating the energy converted by the braking resistor.• Maintain sufficient clearance to objects that can burn.• Do not place any objects on or above the braking resistor.

 CAUTION
Burns resulting from high surface temperature of the braking resistor The braking resistor can become very hot. You can get seriously burnt when touching the surface. <ul style="list-style-type: none">• Mount the braking resistors so that contact is not possible. If this is not possible, attach a clearly visible and understandable warning notice at hazardous positions.

NOTICE
Damage to braking resistor due to ingress of water Water penetration may damage the braking resistor. <ul style="list-style-type: none">• For outdoor installations, a hood must be provided to protect it from precipitation in accordance with degree of protection IP20.

Note

Braking resistor/fire alarm sensor interaction

If a braking resistor is placed underneath a fire alarm sensor, then the heat produced may trigger the fire alarm sensor.

7.2.3 Dimension drawing

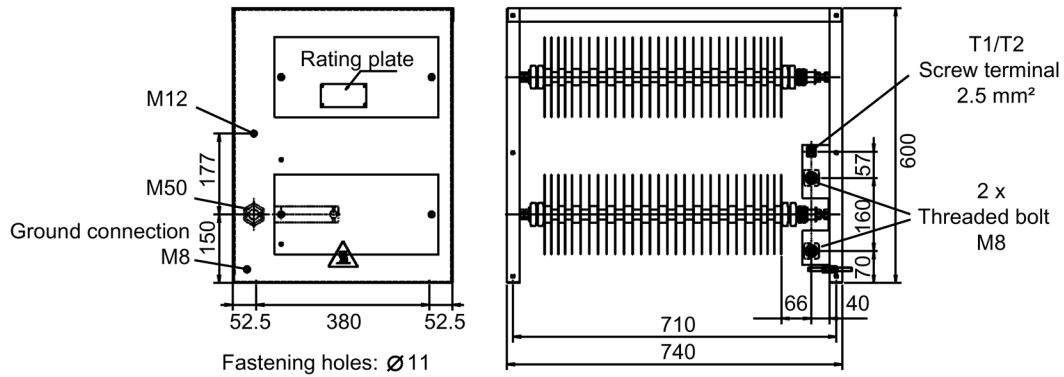

Figure 7-14 Dimension drawing braking resistor 25 kW/125 kW

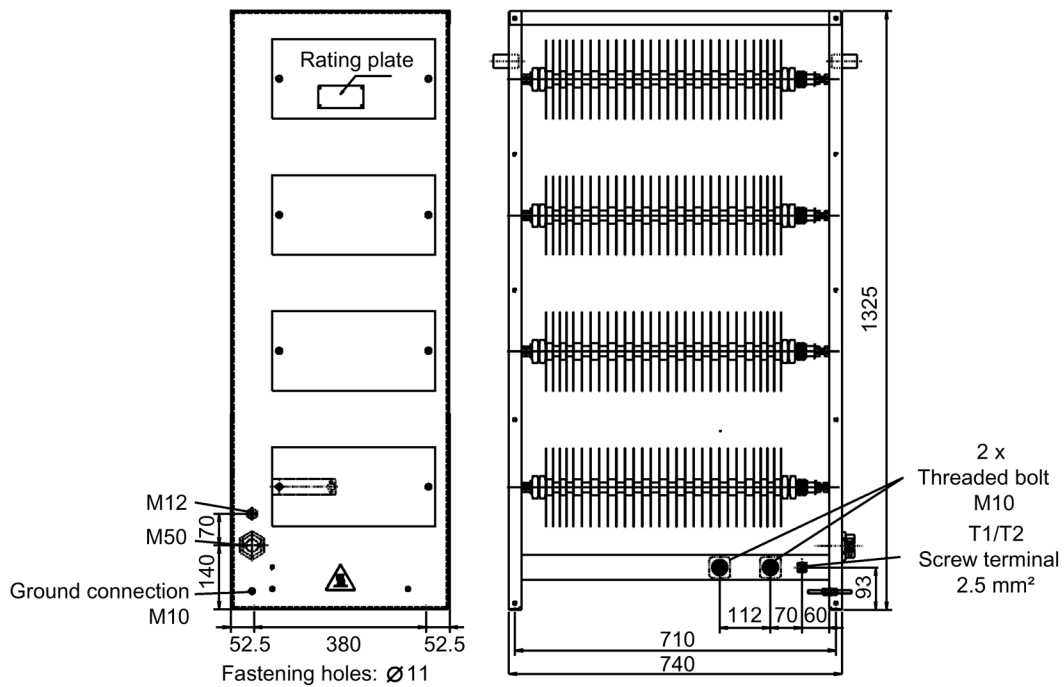

Figure 7-15 Dimension drawing braking resistor 50 kW/250 kW

7.2.4 Electrical connection

Recommended cable cross-sections:

- For 25/125 kW: 35 mm²
- For 50/250 kW: 50 mm²

Thermostatic switch

A thermostatic switch is installed to protect the braking resistor against overload. Its floating contacts must be integrated in the fault chain on the line side.

Table 7- 7 Thermostatic switch connection

Terminal	Function	Technical specifications
T1	Thermostatic switch connection	Voltage: 240 V AC Load current: Max. 10 A
T2	Thermostatic switch connection	

Max. connectable cross-section: 2.5 mm²

7.2.5 Technical data

Table 7- 8 Technical data, braking resistors, 380 V ... 480 V 3 AC

Article number	Unit	6SL3000-1BE31-3AA0	6SL3000-1BE32-5AA0
P _{DB} (rated power)	kW	25	50
P ₁₅ (peak power)	kW	125	250
Max. current	A	189	378
Resistance	Ω	4.4 (± 7.5%)	2.2 (± 7.5%)
Cable entry		via M50 cable gland	via M50 cable gland
Power connection		via M8 bolt-type terminal	via M10 bolt-type terminal
Max. connectable cable cross-section	mm ²	50	70
Degree of protection		IP20	IP20
Width x height x depth	mm	740 x 605 x 485	810 x 1325 x 485
Weight, approx.	kg	50	120

Table 7- 9 Technical data, braking resistors, 500 V ... 600 V 3 AC

Article number	Unit	6SL3000-1BF31-3AA0	6SL3000-1BF32-5AA0
P _{DB} (rated power)	kW	25	50
P ₁₅ (peak power)	kW	125	250
Max. current	A	153	306
Resistance	Ω	6.8 (± 7.5%)	3.4 (± 7.5%)
Cable entry		via M50 cable gland	via M50 cable gland
Power connection		via M8 bolt-type terminal	via M10 bolt-type terminal
Max. connectable cable cross-section	mm ²	50	70
Degree of protection		IP20	IP20
Width x height x depth	mm	740 x 605 x 485	810 x 1325 x 485
Weight, approx.	kg	50	120

Table 7- 10 Technical data, braking resistors, 660 V ... 690 V 3 AC

Article number	Unit	6SL3000-1BH31-3AA0	6SL3000-1BH32-5AA0
P _{DB} (rated power)	kW	25	50
P ₁₅ (peak power)	kW	125	250
Max. current	A	125	255
Resistance	Ω	9.8 (± 7.5%)	4.9 (± 7.5%)
Cable entry		via M50 cable gland	via M50 cable gland
Power connection		via M8 bolt-type terminal	via M10 bolt-type terminal
Max. connectable cable cross-section	mm ²	50	70
Degree of protection		IP20	IP20
Width x height x depth	mm	740 x 605 x 485	810 x 1325 x 485
Weight, approx.	kg	50	120

Duty cycle

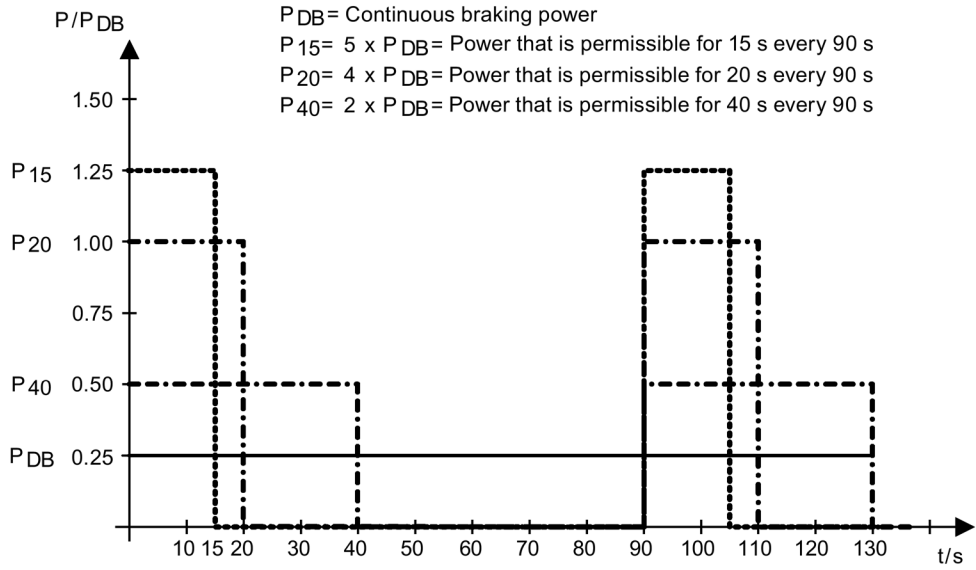

Figure 7-16 Duty cycle for braking resistors

Motor-side power components

8.1 Sine-wave filter

8.1.1 Description

If a sine-wave filter is connected to the output of the Motor Module, the voltage between the motor terminals is virtually sinusoidal. This reduces the voltage load on the motor windings and prevents motor noise that would be induced by the pulse frequency.

Sine-wave filters are available up to a converter type power rating of 250 kW (without consideration for derating).

The pulse frequency of the Motor Modules must be set to 4 kHz for the sine-wave filters. This reduces the output current of the Motor Module.

When a sine-wave filter is used, the available output voltage decreases by 15%.

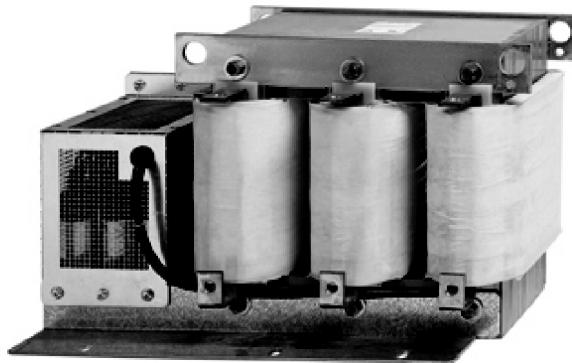





Figure 8-1 Sine-wave filter

8.1.2 Safety information

 WARNING
Not observing fundamental safety instructions and residual risks
Not observing fundamental safety instructions and residual risks listed in Chapter 1 can result in accidents with severe injuries or death.
<ul style="list-style-type: none">• Comply with the fundamental safety instructions.• When assessing the risk, take into account remaining risks.

 WARNING
Fire due to overheating because of inadequate ventilation clearances
Inadequate ventilation clearances can cause overheating with a risk for personnel through smoke development and fire. Furthermore, an increased number of failures and shorter service life of the components can occur.
<ul style="list-style-type: none">• Maintain 100 mm ventilation clearances above and to the side of the component.

 CAUTION
Burns resulting from high surface temperature of the sine-wave filter
The surface temperature of the sine-wave filters can exceed 80 °C. You can get seriously burnt when touching the surface.
<ul style="list-style-type: none">• Mount the sine-wave filter so that it cannot be touched. If this is not possible, attach a clearly visible and understandable warning notice at hazardous positions.

NOTICE
Sine-wave filter damage due to interchanged connections
Interchanging the input and output connections will damage the sine-wave filter.
<ul style="list-style-type: none">• Connect the incoming cable from the Motor Module to 1U1, 1V1, 1W1.• Connect the outgoing cable to the load at 1U2, 1V2, 1W2.

NOTICE
Damage to the Motor Module by using components that have not been released
When using components that have not been released, damage or malfunctions can occur at the devices or the system itself.
<ul style="list-style-type: none">• Only use sine-wave filters that SIEMENS has released for SINAMICS.

NOTICE**Risk of damaging sine-wave filter by exceeding the maximum output frequency**

The maximum permissible output frequency when sine-wave filters are used is 150 Hz. The sine-wave filter can be damaged if the output frequency is exceeded.

- Operate the sine-wave filter with a maximum output frequency of 150 Hz.

NOTICE**Damage to the sine-wave filter if it is not activated during commissioning**

The sine-wave filter may be damaged if it is not activated during commissioning.

- Activate the sine-wave filter during commissioning via parameter p0230 = 3.

NOTICE**Damage to the sine-wave filter if a motor is not connected**

Sine-wave filters, which are operated without a motor being connected, can be damaged or destroyed.

- Never operate a sine-wave filter connected to the Motor Module without a connected motor.

Note**Cable lengths**

Keep the connecting cables to the Motor Module as short as possible (max. 5 m).

8.1.3 Dimension drawing

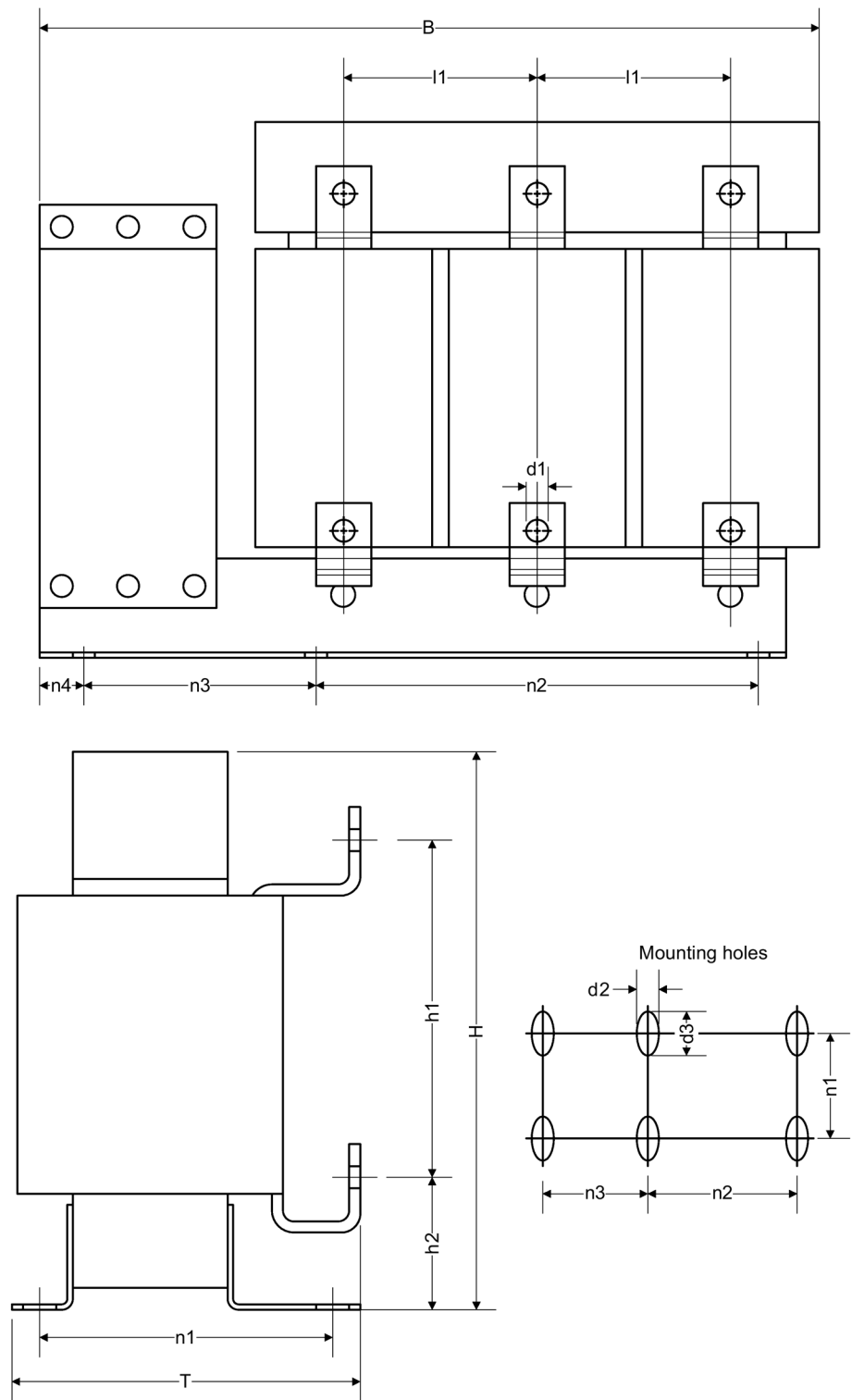

Figure 8-2 Dimension drawing, sine-wave filter

Table 8- 1 Dimensions of the sine-wave filter (all values in mm)

6SL3000-	2CE32-3AA0	2CE32-8AA0	2CE33-3AA0	2CE34-1AA0
W	620	620	620	620
H	300	300	370	370
D	320	320	360	360
l1	140	140	140	140
h1	180	180	220	220
h2	65	65	65	65
n1 ¹⁾	280	280	320	320
n2 ¹⁾	150	150	150	150
n3 ¹⁾	225	225	225	225
n4	105	105	105	105
d1	12	12	12	12
d2	11	11	11	11
d3	22	22	22	22

¹⁾ The lengths n1, n2 and n3 correspond to the drill hole spacing

8.1.4 Technical data

Table 8- 2 Technical data of sine-wave filters 380 V ... 480 V 3 AC

Article number	6SL3000-	2CE32-3AA0	2CE32-3AA0	2CE32-8AA0	2CE33-3AA0	2CE34-1AA0
Suitable for Motor Module	6SL3320-	1TE32-1AA3	1TE32-6AA3	1TE33-1AA3	1TE33-8AA3	1TE35-0AA3
Rated current (type rating) of the Motor Module with sine-wave filter at a pulse frequency of 4 kHz		170 A (90 kW)	215 A (110 kW)	270 A (132 kW)	330 A (160 kW)	380 A (200 kW)
Rated current	A	225	225	276	333	408
Maximum output frequency	Hz	150	150	150	150	150
Power loss						
- at 50 Hz	kW	0.35	0.35	0.4	0.245	0.38
- at 150 Hz	kW	0.6	0.6	0.69	0.53	0.7
Connections		M10 connecting lugs M10 connecting lugs				
- to the Motor Module						
- load						
Max. permissible cable length between sine-wave filter and motor	m	300 (shielded) 450 (unshielded)				
Degree of protection		IP00	IP00	IP00	IP00	IP00
Dimensions						
Width	mm	620	620	620	620	620
Height	mm	300	300	300	370	370
Depth	mm	320	320	320	360	360
Weight	kg	124	124	127	136	198

8.2 Motor reactors

8.2.1 Description

Motor reactors reduce the voltage stress on the motor windings by reducing the voltage gradients at the motor terminals that occur when motors are fed from drive converters. At the same time, the capacitive charge/discharge currents that also occur on the output of the Motor Module when long motor cables are used are reduced.

Table 8- 3 Maximum pulse frequency when using a motor reactor with devices with a rated pulse frequency of 2 kHz

Article No. of the Motor Module 6SL3320-...	Type rating [kW]	Output current for a pulse frequency of 2 kHz [A]	Maximum pulse frequency when using a motor reactor
Line voltage 3 AC 380 ... 480 V			
1TE32-1AA3	110	210	4 kHz
1TE32-6AA3	132	260	4 kHz
1TE33-1AA3	160	310	4 kHz
1TE33-8AA3	200	380	4 kHz
1TE35-0AA3	250	490	4 kHz
1TE41-4AS3	800	1330	4 kHz

Table 8- 4 Maximum pulse frequency when using a motor reactor with devices with a rated pulse frequency of 1.25 kHz

Article No. of the Motor Module 6SL3320-...	Type rating [kW]	Output current for a pulse frequency of 1.25 kHz [A]	Maximum pulse frequency when using a motor reactor
Line voltage 3 AC 380 ... 480 V			
1TE36-1AA3	315	605	2.5 kHz
1TE37-5AA3	400	745	2.5 kHz
1TE38-4AA3	450	840	2.5 kHz
1TE41-0AA3	560	985	2.5 kHz
1TE41-2AA3	710	1260	2.5 kHz
1TE41-4AA3	800	1405	2.5 kHz

Article No. of the Motor Module 6SL3320-...	Type rating [kW]	Output current for a pulse frequency of 1.25 kHz [A]	Maximum pulse frequency when using a motor reactor
Line voltage 3 AC 500 ... 690 V			
1TG28-5AA3	75	85	2.5 kHz
1TG31-0AA3	90	100	2.5 kHz
1TG31-2AA3	110	120	2.5 kHz
1TG31-5AA3	132	150	2.5 kHz
1TG31-8AA3	160	175	2.5 kHz
1TG32-2AA3	200	215	2.5 kHz
1TG32-6AA3	250	260	2.5 kHz
1TG33-3AA3	315	330	2.5 kHz
1TG34-1AA3	400	410	2.5 kHz
1TG34-7AA3	450	465	2.5 kHz
1TG35-8AA3	560	575	2.5 kHz
1TG37-4AA3	710	735	2.5 kHz
1TG38-1AA3	800	810	2.5 kHz
1TG38-8AA3	900	910	2.5 kHz
1TG41-0AA3	1000	1025	2.5 kHz
1TG41-3AA3	1200	1270	2.5 kHz

Table 8- 5 Maximum pulse frequency when using a motor reactor with devices with a rated pulse frequency of 2.5 kHz

Article No. of the Motor Module Chassis-2 6SL3321-...	Type rating [kW]	Output current for a pulse frequency of 2.5 kHz [A]	Maximum pulse frequency when using a motor reactor
Line voltage 3 AC 380 ... 480 V			
1TE41-0AA0	500	975	2.5 kHz
1TE41-1AA0	560	1075	2.5 kHz
1TE41-2AA0	630	1200	2.5 kHz

8.2.2 Safety information

 **WARNING**

Not observing fundamental safety instructions and residual risks

Not observing fundamental safety instructions and residual risks listed in Chapter 1 can result in accidents with severe injuries or death.

- Comply with the fundamental safety instructions.
- When assessing the risk, take into account remaining risks.

 **WARNING**

Fire due to overheating because of inadequate ventilation clearances

Inadequate ventilation clearances can cause overheating with a risk for personnel through smoke development and fire. Furthermore, an increased number of failures and shorter service life of the components can occur.

- Maintain 100 mm ventilation clearances above and to the side of the component.

 **CAUTION**

Burns resulting from high surface temperature of the motor reactor

The surface temperature of the motor reactors can exceed 80 °C. You can get seriously burnt when touching the surface.

- Mount the motor reactor so that it cannot be touched. If this is not possible, attach a clearly visible and understandable warning notice at hazardous positions.

NOTICE

Damage to the Motor Module by using components that have not been released

When using components that have not been released, damage or malfunctions can occur at the devices or the system itself.

- Only use motor reactors that SIEMENS has released for SINAMICS.

NOTICE

Risk of damaging the motor reactor by exceeding the maximum output frequency

The maximum permissible output frequency when a motor reactor is used is 150 Hz. The motor reactor can be damaged if the output frequency is exceeded.

- Operate the motor reactor with a maximum output frequency of 150 Hz.

NOTICE

Damage to the motor reactor if the maximum pulse frequency is exceeded

The maximum permissible pulse frequency when a motor reactor is used is 2.5 kHz or 4 kHz. The motor reactor can be damaged if the pulse frequency is exceeded.

- When using the motor reactor, operate the Motor Module with a maximum pulse frequency of 2.5 kHz or 4 kHz.

NOTICE

Damage to the motor reactor if it is not activated during commissioning

The motor reactor may be damaged if it is not activated during commissioning.

- Activate the motor reactor during commissioning via parameter p0230 = 1.

Note

Cable lengths

Keep the connecting cables to the Motor Module as short as possible (max. 5 m).

8.2.3 Dimension drawing

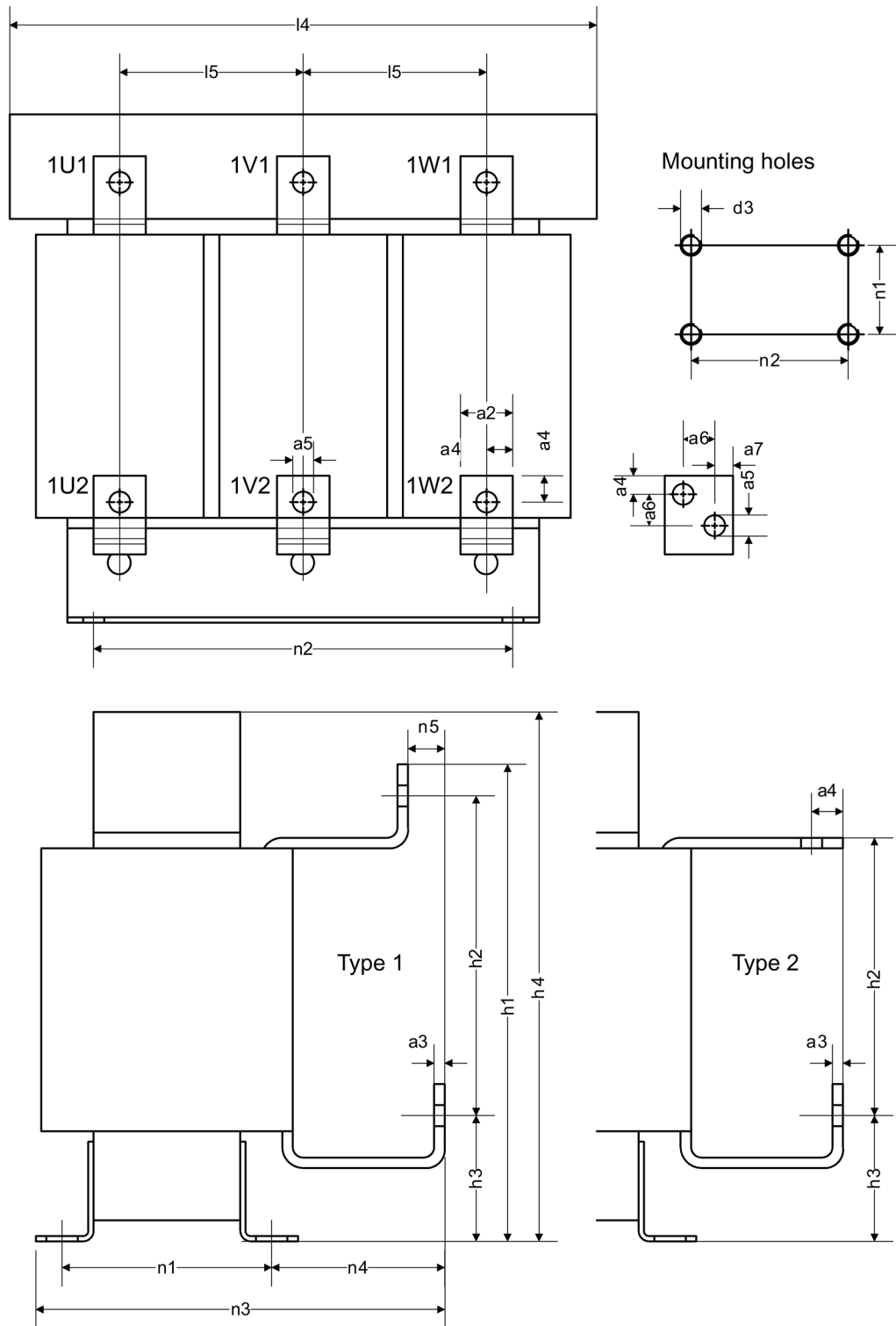

Figure 8-3 Dimension drawing, motor reactor

Table 8- 6 Dimensions of motor reactors, 3 AC 380 V ... 480 V, Part 1 (all specifications in mm)

6SL3000-	2BE32-1AA0	2BE32-6AA0	2BE33-2AA0	2BE33-8AA0	2BE35-0AA0
Connection type	Type 1	Type 1	Type 1	Type 1	Type 2
a2	25	25	25	25	30
a3	5	5	5	5	6
a4	12.5	12.5	12.5	12.5	15
a5	11	11	11	11	14
l4	300	300	300	300	300
l5	100	100	100	100	100
h1	-	-	-	-	-
h2	194	227	194	194	245
h3	60	60	60	60	60
h4	285	315	285	285	365
n1 ¹⁾	163	183	163	183	183
n2 ¹⁾	224	224	224	224	224
n3	257	277	257	277	277
n4	79	79	79	79	79
d3	M8	M8	M8	M8	M8

¹⁾ Lengths n1 and n2 correspond to the distance between holes

Table 8- 7 Dimensions of motor reactors, 3 AC 380 V ... 480 V, Part 2 (all specifications in mm)

6SL3000-	2AE36-1AA0	2AE38-4AA0	2AE41-0AA0	2AE41-4AA0	
Connection type	Type 1	Type 1	Type 1	Type 1	
a2	40	40	40	60	
a3	8	8	8	12	
a4	20	20	20	17	
a5	14	14	14	14	
a6	-	-	-	22	
a7	-	-	-	19	
l4	410	410	410	460	
l5	140	140	140	160	
h1	392	392	392	392	
h2	252	252	252	255	
h3	120	120	120	120	
h4	385	385	385	385	
n1 ¹⁾	191	191	206	212	
n2 ¹⁾	316	316	316	356	
n3	292	292	302	326	
n4	84.5	84.5	79.5	94.5	
n5	30	30	-	-	
d3	M10	M10	M10	M10	

¹⁾ Lengths n1 and n2 correspond to the distance between holes

8.2 Motor reactors

Table 8- 8 Dimensions of motor reactors, 3 AC 500 V ... 690 V, Part 1 (all specifications in mm)

6SL3000-	2AH31-0AA0	2AH31-5AA0	2AH31-8AA0	2AH32-4AA0	2AH32-6AA0
Connection type	Type 1	Type 1	Type 1	Type 1	Type 1
a2	25	25	25	25	25
a3	5	5	5	5	5
a4	12.5	12.5	12.5	12.5	12.5
a5	11	11	11	11	11
l4	270	270	300	300	300
l5	88	88	100	100	100
h1	-	-	-	-	-
h2	150	150	194	194	194
h3	60	60	60	60	60
h4	248	248	285	285	285
n1 ¹⁾	103	103	118	118	118
n2 ¹⁾	200	200	224	224	224
n3	200	200	212	212	212
n4	82	82	79	79	79
d3	M8	M8	M8	M8	M8

¹⁾ Lengths n1 and n2 correspond to the distance between holes

Table 8- 9 Dimensions of motor reactors, 3 AC 500 V ... 690 V, Part 2 (all specifications in mm)

6SL3000-	2AH33-6AA0	2AH34-5AA0	2AH34-7AA0	2AH35-8AA0	2AH38-1AA0
Connection type	Type 1	Type 1	Type 1	Type 1	Type 1
a2	25	30	40	40	40
a3	5	6	8	8	8
a4	12.5	15	20	20	20
a5	11	14	14	14	14
l4	300	350	410	410	410
l5	100	120	140	140	140
h1	-	-	392	392	392
h2	194	235	252	252	252
h3	60	60	120	120	120
h4	285	330	385	385	385
n1 ¹⁾	118	138	141	141	183
n2 ¹⁾	224	264	316	316	316
n3	212	215	292	292	279
n4	79	63	134.5	134.5	79.5
n5	-	-	30	30	-
d3	M8	M8	M10	M10	M10

¹⁾ Lengths n1 and n2 correspond to the distance between holes

Table 8- 10 Dimensions of motor reactors, 3 AC 500 V ... 690 V, Part 3 (all specifications in mm)

6SL3000-	2AH41-0AA0	2AH41-1AA0	2AH41-3AA0		
Connection type	Type 1	Type 1	Type 1		
a2	40	50	60		
a3	8	8	12		
a4	20	14	17		
a5	14	14	14		
a6	-	22	22		
a7	-	-	19		
l4	410	410	460		
l5	140	140	160		
h1	392	392	392		
h2	252	258	255		
h3	120	120	120		
h4	385	385	385		
n1 ¹⁾	183	206	182		
n2 ¹⁾	316	316	356		
n3	279	317	296		
n4	79.5	94.5	94.5		
d3	M10	M10	M10		

¹⁾ Lengths n1 and n2 correspond to the distance between holes

8.2.4 Technical data

Table 8- 11 Technical data of motor reactors, 3 AC 380 V ... 480 V, Part 1

Article number	6SL3000-	2BE32-1AA0	2BE32-6AA0	2BE33-2AA0	2BE33-8AA0
Suitable for Motor Module	6SL3320-	1TE32-1AA3	1TE32-6AA3	1TE33-1AA3	1TE33-8AA3
Type rating of the Motor Module	kW	110	132	160	200
Rated current	A	210	260	310	380
Power loss					
- At 50 Hz	kW	0.436	0.454	0.422	0.447
- At 150 Hz	kW	0.486	0.5	0.47	0.5
Connections					
- To the Motor Module (1U1, 1V1, 1W1)		M10	M10	M10	M10
- Load (1U2, 1V2, 1W2)		M10	M10	M10	M10
- PE		M8	M8	M8	M8
Max. permissible cable length between motor reactor and motor		300 (shielded) / 450 (unshielded)			
- With one motor reactor	m	525 (shielded) / 787 (unshielded)			
- With two motor reactors in series	m				
Degree of protection		IP00	IP00	IP00	IP00
Dimensions					
Width	mm	300	300	300	300
Height	mm	285	315	285	285
Depth	mm	257	277	257	277
Weight, approx.	kg	66	66	66	73

Table 8- 12 Technical data of motor reactors, 3 AC 380 ... 480 V, Part 2

Article number	6SL3000-	2BE35-0AA0	2AE36-1AA0	2AE38-4AA0	2AE38-4AA0
Suitable for Motor Module	6SL3320-	1TE35-0AA3	1TE36-1AA3	1TE37-5AA3	1TE38-4AA3
Type rating of the Motor Module	kW	250	315	400	450
Rated current	A	490	605	840	840
Power loss					
- At 50 Hz	kW	0.448	0.798	0.75	0.834
- At 150 Hz	kW	0.5	0.9	0.84	0.943
Connections					
- To the Motor Module (1U1, 1V1, 1W1)		M12	M12	M12	M12
- Load (1U2, 1V2, 1W2)		M12	M12	M12	M12
- PE		M8	M10	M10	M10
Max. permissible cable length between motor reactor and motor		300 (shielded) / 450 (unshielded)			
- With one motor reactor	m	525 (shielded) / 787 (unshielded)			
- With two motor reactors in series	m				
Degree of protection		IP00	IP00	IP00	IP00
Dimensions					
Width	mm	300	410	410	410
Height	mm	365	392	392	392
Depth	mm	277	292	292	292
Weight, approx.	kg	100	130	140	140

Table 8- 13 Technical data of motor reactors, 3 AC 380 ... 480 V, Part 3

Article number	6SL3000-	2AE41-0AA0	2AE41-4AA0	2AE41-4AA0	2AE41-4AA0
Suitable for Motor Module	6SL3320-	1TE41-0AA3	1TE41-2AA3	1TE41-4AA3	1TE41-4AS3
Type rating of the Motor Module	kW	560	710	800	800
Rated current	A	985	1405	1405	1405
Power loss					
- At 50 Hz	kW	0.939	0.81	0.946	0.946
- At 150 Hz	kW	1.062	0.9	1.054	1.054
Connections					
- To the Motor Module (1U1, 1V1, 1W1)		M12	2 x M12	2 x M12	2 x M12
- Load (1U2, 1V2, 1W2)		M12	2 x M12	2 x M12	2 x M12
- PE		M10	M10	M10	M10
Max. permissible cable length between motor reactor and motor					
- With one motor reactor	m	300 (shielded) / 450 (unshielded)			
- With two motor reactors in series	m	525 (shielded) / 787 (unshielded)			
Degree of protection		IP00	IP00	IP00	IP00
Dimensions					
Width	mm	410	460	460	460
Height	mm	392	392	392	392
Depth	mm	302	326	326	326
Weight, approx.	kg	146	179	179	179

Table 8- 14 Technical data of motor reactors 380 V ... 480 V 3 AC, Part 4

Article number	6SL3000-	2AE41-4AA0			
Matching Motor Module Chassis-2	6SL3321-	1TE41-0AA0 1TE41-1AA0 1TE41-2AA0			
Type rating of the Motor Module	kW	500 / 560 / 630			
Rated current	A	1405			
Power loss					
- at 50 Hz	kW	0.946			
- at 150 Hz	kW	1.054			
Connections					
- to the Motor Module (1U1, 1V1, 1W1)		2 x M12			
- load (1U2, 1V2, 1W2)		2 x M12			
- PE		M10			
Max. permissible cable length between motor reactor and motor					
- With 1 motor reactor	m	300 (shielded) / 450 (unshielded)			
- With 2 motor reactors in series	m	450 (shielded) / 675 (unshielded)			
Degree of protection		IP00			
Dimensions					
Width	mm	460			
Height	mm	392			
Depth	mm	326			
Weight, approx.	kg	179			

8.2 Motor reactors

Table 8- 15 Technical data of motor reactors, 3 AC 500 ... 690 V, Part 1

Article number	6SL3000-	2AH31-0AA0	2AH31-0AA0	2AH31-5AA0	2AH31-5AA0
Suitable for Motor Module	6SL3320-	1TG28-5AA3	1TG31-0AA3	1TG31-2AA3	1TG31-5AA3
Type rating of the Motor Module	kW	75	90	110	132
Rated current	A	100	100	150	150
Power loss					
- At 50 Hz	kW	0.215	0.269	0.237	0.296
- At 150 Hz	kW	0.26	0.3	0.26	0.332
Connections					
- To the Motor Module (1U1, 1V1, 1W1)		M10	M10	M10	M10
- Load (1U2, 1V2, 1W2)		M10	M10	M10	M10
- PE		M6	M6	M6	M6
Max. permissible cable length between motor reactor and motor					
- With one motor reactor	m	300 (shielded) / 450 (unshielded)			
- With two motor reactors in series	m	525 (shielded) / 787 (unshielded)			
Degree of protection		IP00	IP00	IP00	IP00
Dimensions					
Width	mm	270	270	270	270
Height	mm	248	248	248	248
Depth	mm	200	200	200	200
Weight, approx.	kg	25	25	25.8	25.8

Table 8- 16 Technical data of motor reactors, 3 AC 500 ... 690 V, Part 2

Article number	6SL3000-	2AH31-8AA0	2AH32-4AA0	2AH32-6AA0	2AH33-6AA0
Suitable for Motor Module	6SL3320-	1TG31-8AA3	1TG32-2AA3	1TG32-6AA3	1TG33-3AA3
Type rating of the Motor Module	kW	160	200	250	315
Rated current	A	175	215	260	330
Power loss					
- At 50 Hz	kW	0.357	0.376	0.389	0.4
- At 150 Hz	kW	0.403	0.425	0.441	0.454
Connections					
- To the Motor Module (1U1, 1V1, 1W1)		M10	M10	M10	M10
- Load (1U2, 1V2, 1W2)		M10	M10	M10	M10
- PE		M6	M6	M6	M6
Max. permissible cable length between motor reactor and motor					
- With one motor reactor	m	300 (shielded) / 450 (unshielded)			
- With two motor reactors in series	m	525 (shielded) / 787 (unshielded)			
Degree of protection		IP00	IP00	IP00	IP00
Dimensions					
Width	mm	300	300	300	300
Height	mm	285	285	285	285
Depth	mm	212	212	212	212
Weight, approx.	kg	34	34	40	46

Table 8- 17 Technical data of motor reactors, 3 AC 500 ... 690 V, Part 3

Article number	6SL3000-	2AH34-5AA0	2AH34-7AA0	2AH35-8AA0	2AH38-1AA0
Suitable for Motor Module	6SL3320-	1TG34-1AA3	1TG34-7AA3	1TG35-8AA3	1TG37-4AA3
Type rating of the Motor Module	kW	400	450	560	710
Rated current	A	410	465	575	810
Power loss					
- At 50 Hz	kW	0.481	0.631	0.705	0.78
- At 150 Hz	kW	0.545	0.723	0.801	0.91
Connections					
- To the Motor Module (1U1, 1V1, 1W1)		M12	M12	M12	M12
- Load (1U2, 1V2, 1W2)		M12	M12	M12	M12
- PE		M8	M8	M8	M8
Max. permissible cable length between motor reactor and motor					
- With one motor reactor	m	300 (shielded) / 450 (unshielded)			
- With two motor reactors in series	m	525 (shielded) / 787 (unshielded)			
Degree of protection		IP00	IP00	IP00	IP00
Dimensions					
Width	mm	350	410	410	410
Height	mm	330	392	392	392
Depth	mm	215	292	292	279
Weight, approx.	kg	68	80	80	146

Table 8- 18 Technical data of motor reactors, 3 AC 500 ... 690 V, Part 4

Article number	6SL3000-	2AH38-1AA0	2AH41-0AA0	2AH41-1AA0	2AH41-3AA0
Suitable for Motor Module	6SL3320-	1TG38-1AA3	1TG38-8AA3	1TG41-0AA3	1TG41-3AA3
Type rating of the Motor Module	kW	800	900	1000	1200
Rated current	A	810	910	1025	1270
Power loss					
- At 50 Hz	kW	0.877	0.851	0.927	0.862
- At 150 Hz	kW	1.003	0.965	1.052	0.952
Connections					
- To the Motor Module (1U1, 1V1, 1W1)		M12	M12	M12	M12
- Load (1U2, 1V2, 1W2)		M12	M12	M12	M12
- PE		M8	M8	M8	M8
Max. permissible cable length between motor reactor and motor					
- With one motor reactor	m	300 (shielded) / 450 (unshielded)			
- With two motor reactors in series	m	525 (shielded) / 787 (unshielded)			
Degree of protection		IP00	IP00	IP00	IP00
Dimensions					
Width	mm	410	410	410	460
Height	mm	392	392	392	392
Depth	mm	279	279	317	296
Weight, approx.	kg	146	150	163	153

8.3 dV/dt filter plus Voltage Peak Limiter

8.3.1 Description

The dV/dt filter plus voltage peak limiter comprises two components: The dV/dt reactor and the voltage-limiting network (voltage peak limiter) which cuts off the voltage peaks and returns energy to the DC link. The dV/dt filters plus voltage peak limiter must be used for motors for which the proof voltage of the insulation system is unknown or insufficient.

dV/dt filters plus voltage peak limiters limit the rate of voltage rise to values $< 500 \text{ V}/\mu\text{s}$ and the typical voltage peaks with rated line voltages to the values below:

- $< 1000 \text{ V}$ at $U_{\text{line}} < 575 \text{ V}$
- $< 1250 \text{ V}$ at $660 \text{ V} < U_{\text{line}} < 690 \text{ V}$.

Components

The article numbers of the individual components (dV/dt reactor and Voltage Peak Limiter) are listed in the following table:

Table 8- 19 dV/dt filter plus Voltage Peak Limiter, article numbers of the individual components

dV/dt filter plus voltage peak limiter	dV/dt reactor	Voltage peak limiter
Line voltage 3 AC 380 ... 480 V		
6SL3000-2DE32-6AA0	6SL3000-2DE32-6CA0	6SL3000-2DE32-6BA0
6SL3000-2DE35-0AA0	6SL3000-2DE35-0CA0	6SL3000-2DE35-0BA0
6SL3000-2DE38-4AA0	6SL3000-2DE38-4CA0	6SL3000-2DE38-4BA0
6SL3000-2DE41-4AA0	2 x 6SL3000-2DE41-4DA0	6SL3000-2DE41-4BA0
Line voltage 3 AC 500 ... 690 V		
6SL3000-2DH31-0AA0	6SL3000-2DH31-0CA0	6SL3000-2DH31-0BA0
6SL3000-2DH31-5AA0	6SL3000-2DH31-5CA0	6SL3000-2DH31-5BA0
6SL3000-2DH32-2AA0	6SL3000-2DH32-2CA0	6SL3000-2DH32-2BA0
6SL3000-2DH33-3AA0	6SL3000-2DH33-3CA0	6SL3000-2DH33-3BA0
6SL3000-2DH34-1AA0	6SL3000-2DH34-1CA0	6SL3000-2DH34-1BA0
6SL3000-2DH35-8AA0	6SL3000-2DH35-8CA0	6SL3000-2DH35-8BA0
6SL3000-2DH38-1AA0	2 x 6SL3000-2DH38-1DA0	6SL3000-2DH38-1BA0
6SL3000-2DH41-3AA0	2 x 6SL3000-2DH41-3DA0	6SL3000-2DH41-3BA0

Table 8- 20 Max. pulse frequency when a dV/dt filter is used in devices with a rated pulse frequency of 2 kHz

Article number of the Motor Module 6SL3320-...	Type rating [kW]	Output current for a pulse frequency of 2 kHz [A]	Max. pulse frequency when a dV/dt filter is used
Line voltage 3 AC 380 ... 480 V			
1TE32-1AA3	110	210	4 kHz
1TE32-6AA3	132	260	4 kHz
1TE33-1AA3	160	310	4 kHz
1TE33-8AA3	200	380	4 kHz
1TE35-0AA3	250	490	4 kHz
1TE41-4AS3	800	1330	4 kHz

Table 8- 21 Max. pulse frequency when a dV/dt filter is used in devices with a rated pulse frequency of 1.25 kHz

Article number of the Motor Module 6SL3320-...	Type rating [kW]	Output current for a pulse frequency of 1.25 kHz [A]	Max. pulse frequency when a dV/dt filter is used
Line voltage 3 AC 380 ... 480 V			
1TE36-1AA3	315	605	2.5 kHz
1TE37-5AA3	400	745	2.5 kHz
1TE38-4AA3	450	840	2.5 kHz
1TE41-0AA3	560	985	2.5 kHz
1TE41-2AA3	710	1260	2.5 kHz
1TE41-4AA3	800	1405	2.5 kHz
Line voltage 3 AC 500 ... 690 V			
1TG28-5AA3	75	85	2.5 kHz
1TG31-0AA3	90	100	2.5 kHz
1TG31-2AA3	110	120	2.5 kHz
1TG31-5AA3	132	150	2.5 kHz
1TG31-8AA3	160	175	2.5 kHz
1TG32-2AA3	200	215	2.5 kHz
1TG32-6AA3	250	260	2.5 kHz
1TG33-3AA3	315	330	2.5 kHz
1TG34-1AA3	400	410	2.5 kHz
1TG34-7AA3	450	465	2.5 kHz
1TG35-8AA3	560	575	2.5 kHz
1TG37-4AA3	710	735	2.5 kHz
1TG38-1AA3	800	810	2.5 kHz
1TG38-8AA3	900	910	2.5 kHz
1TG41-0AA3	1000	1025	2.5 kHz
1TG41-3AA3	1200	1270	2.5 kHz

Table 8- 22 Max. pulse frequency when a dV/dt filter is used in units with a rated pulse frequency of 2.5 kHz

Article No. of the Motor Module Chassis-2 6SL3321-...	Type rating [kW]	Output current for a pulse frequency of 2.5 kHz [A]	Max. pulse frequency when a dV/dt filter is used
Line voltage 3 AC 380 ... 480 V			
1TE41-0AA0	500	975	2.5 kHz
1TE41-1AA0	560	1075	2.5 kHz
1TE41-2AA0	630	1200	2.5 kHz

8.3.2 Safety information

 WARNING
<p>Not observing fundamental safety instructions and residual risks</p> <p>Not observing fundamental safety instructions and residual risks listed in Chapter 1 can result in accidents with severe injuries or death.</p> <ul style="list-style-type: none"> • Comply with the fundamental safety instructions. • When assessing the risk, take into account remaining risks.

 WARNING
<p>Fire due to overheating because of inadequate ventilation clearances</p> <p>Inadequate ventilation clearances can cause overheating with a risk for personnel through smoke development and fire. Furthermore, an increased number of failures and shorter service life of the components can occur.</p> <ul style="list-style-type: none"> • Maintain 100 mm clearances above and below the components.

 CAUTION
<p>Burns resulting from high surface temperature of the dV/dt reactor</p> <p>The surface temperature of the dV/dt reactors may exceed 80 °C. You can get seriously burnt when touching the surface.</p> <ul style="list-style-type: none"> • Mount the dV/dt reactor so that it cannot be touched. If this is not possible, attach a clearly visible and understandable warning notice at hazardous positions.

NOTICE

Damage to the Voltage Peak Limiter due to interchanged connections

The Voltage Peak Limiter will be damaged if the input and output connections are interchanged.

- Connect the incoming cable from the DC link of the Motor Module to DCPS, DCNS.
- Connect the incoming cable from the DC link of the Motor Module Chassis-2 to DCP, DCN.
- Connect the outgoing cable for the dV/dt reactor to 1U2, 1V2, 1W2.

NOTICE

Damage to the dV/dt filter by using components that have not been released

When using components that have not been released, damage or malfunctions can occur at the devices or the system itself.

- Only use dV/dt filters that SIEMENS has released for operation with SINAMICS.

NOTICE

Damage to the dV/dt filter by exceeding the maximum output frequency

The maximum permissible output frequency when using a dV/dt filter is 150 Hz. The dV/dt filter can be damaged if the output frequency is exceeded.

- Operate the dV/dt filter with a maximum output frequency of 150 Hz.

NOTICE

Damage to the dV/dt filter by exceeding the maximum pulse frequency

The maximum permissible pulse frequency when using a dV/dt filter is 2.5 kHz or 4 kHz. The dV/dt filter can be damaged if the pulse frequency is exceeded.

- When using the dV/dt filter, operate the Motor Module with a maximum pulse frequency of 2.5 kHz or 4 kHz.

NOTICE

Damage to the dV/dt filter if it is not activated during commissioning

The dV/dt filter may be damaged if it is not activated during commissioning.

- Activate the dV/dt filter during commissioning via parameter p0230 = 2.

NOTICE
Damage to the dV/dt filter if a motor is not connected dV/dt filters which are operated without a motor being connected can be damaged or destroyed. <ul style="list-style-type: none">• Never operate a dV/dt filter connected to the Motor Module without a connected motor.

Note

Cable lengths

Keep the connecting cables to the Motor Module as short as possible (max. 5 m).

8.3.3 Interface description

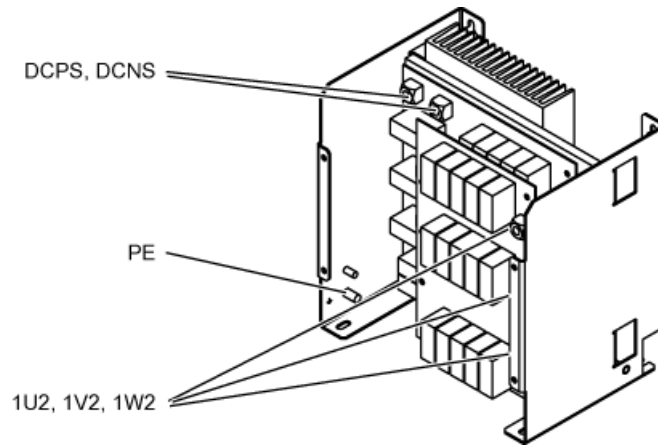

Figure 8-4 Interface overview, voltage peak limiter, type 1

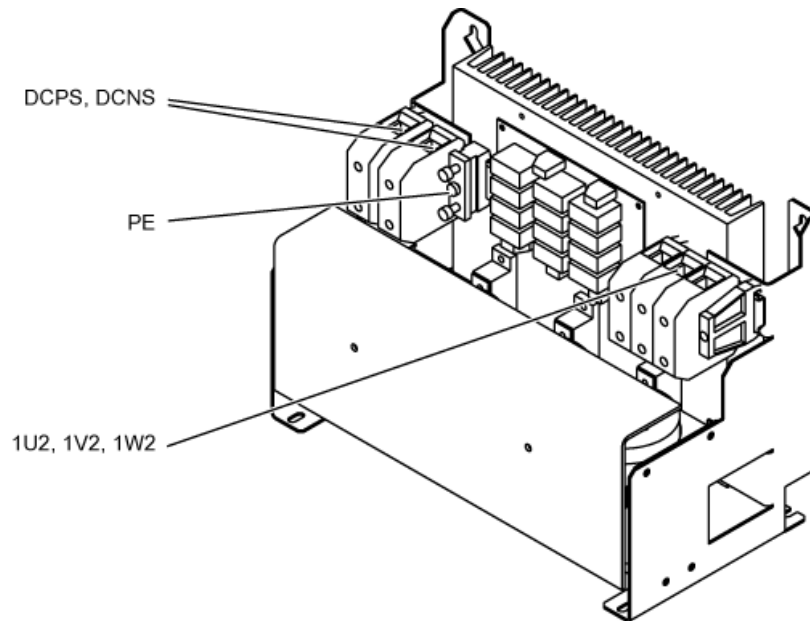

Figure 8-5 Interface overview, voltage peak limiter, type 2

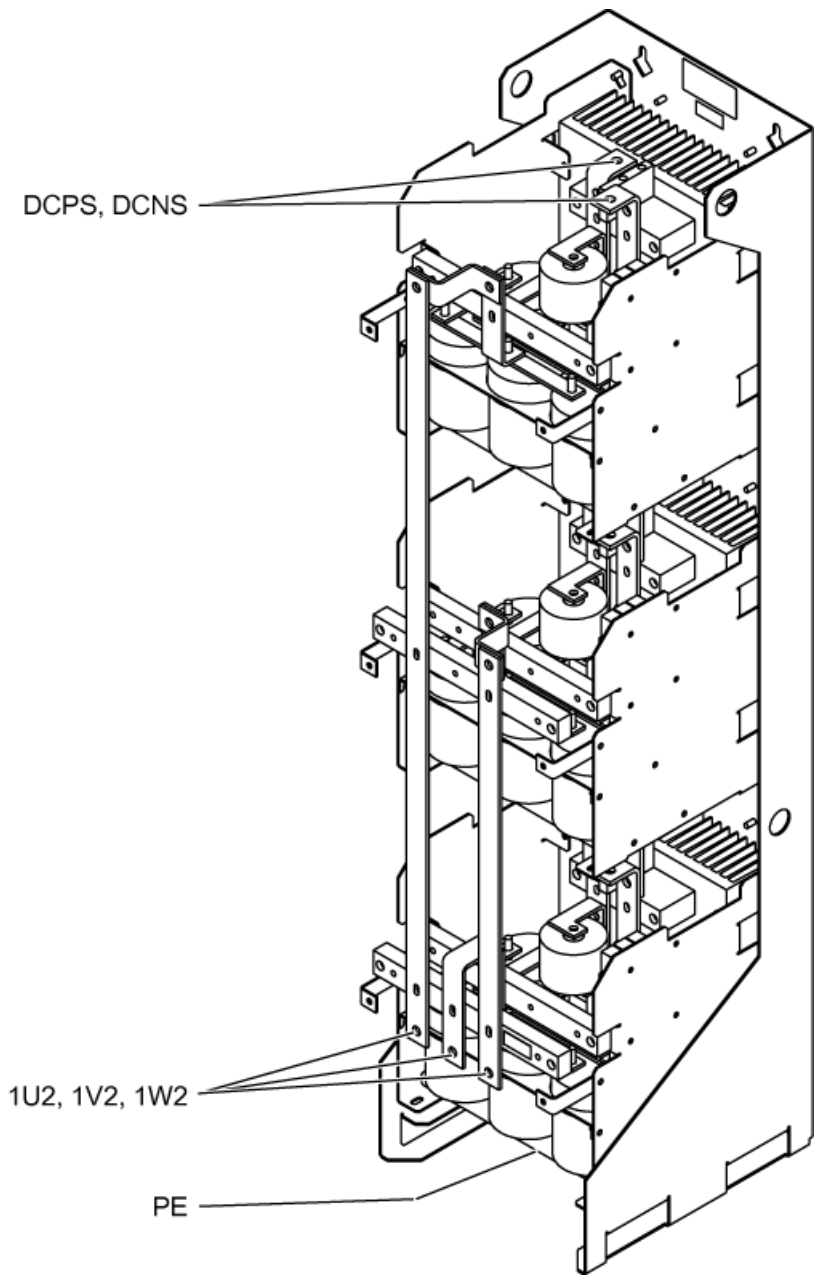

Figure 8-6 Interface overview, voltage peak limiter, type 3

8.3.4 Connecting the dV/dt filter plus Voltage Peak Limiter

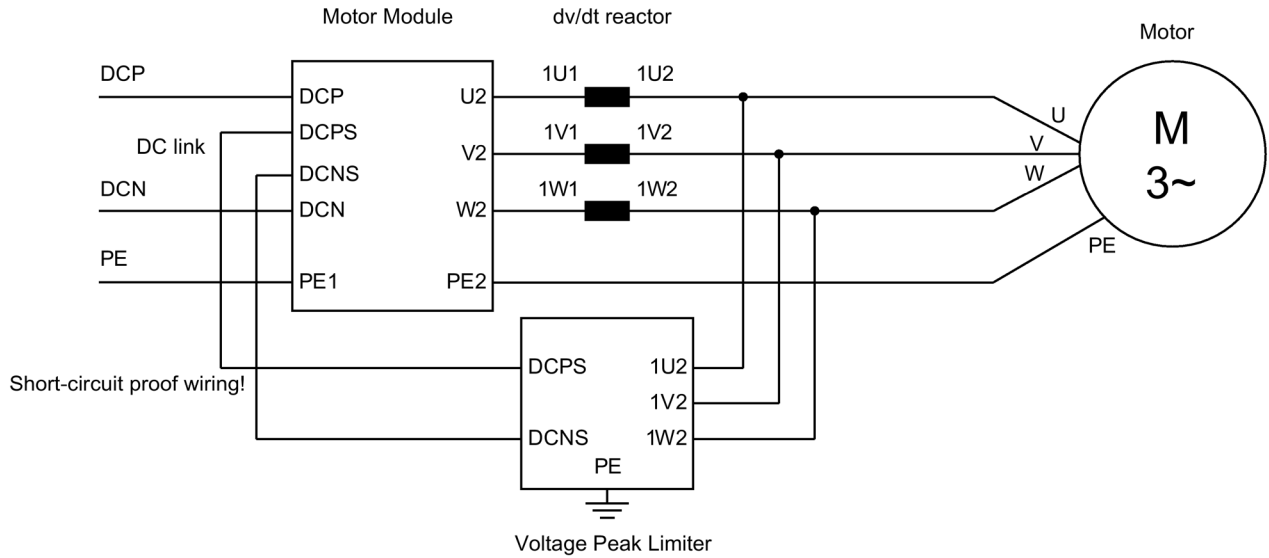

Figure 8-7 Connecting a dV/dt filter plus voltage peak limiter for versions with one dV/dt reactor

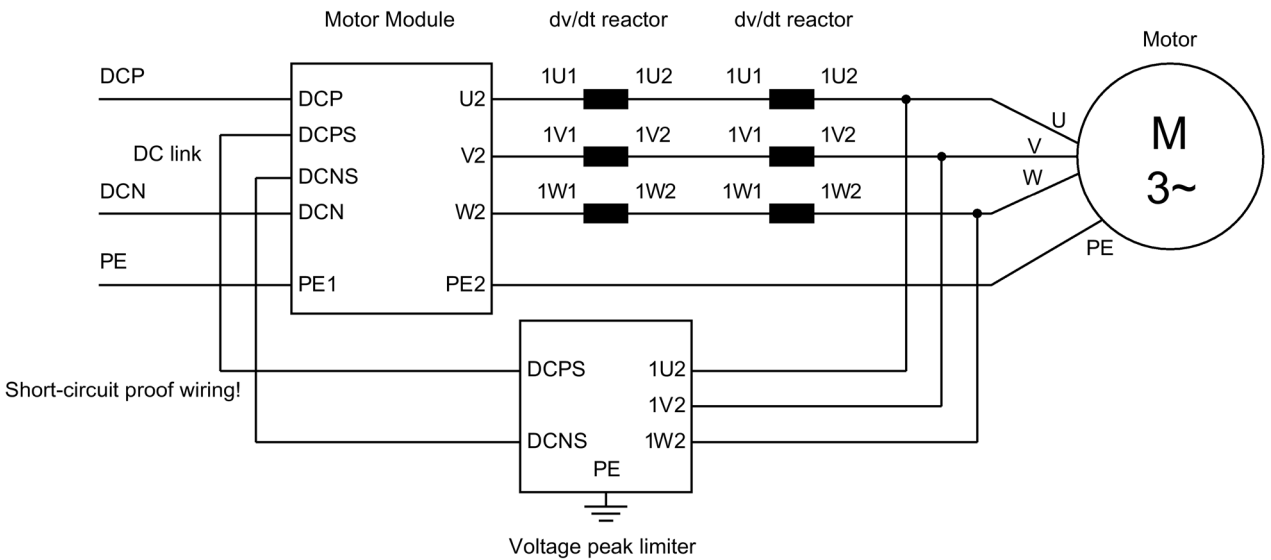

Figure 8-8 Connecting a dV/dt filter plus voltage peak limiter for versions with two dV/dt reactors

8.3 dV/dt filter plus Voltage Peak Limiter

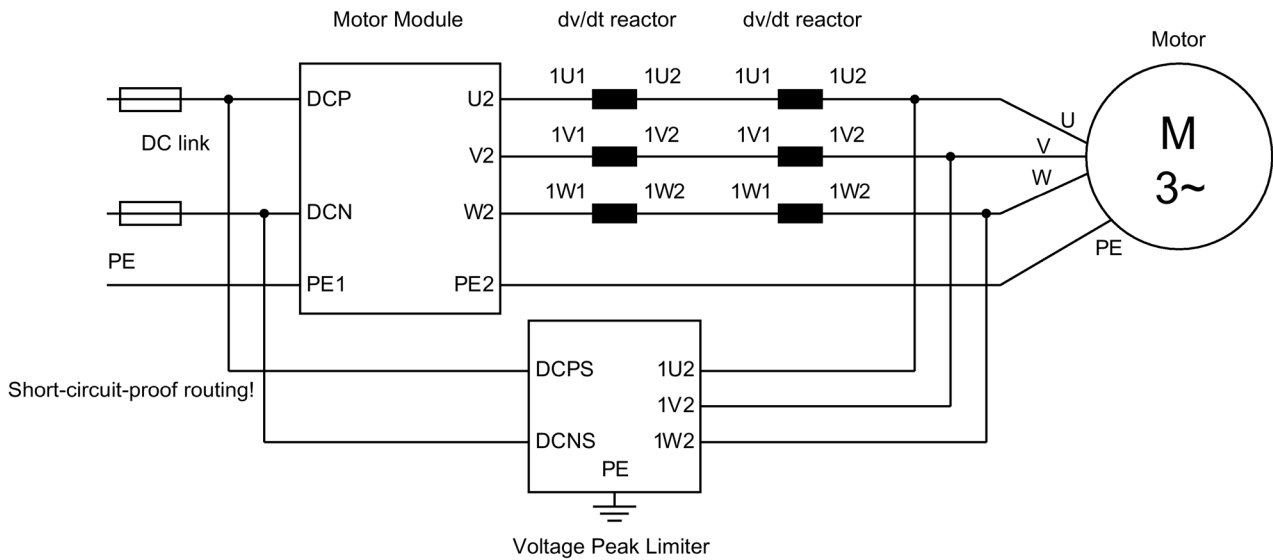

Figure 8-9 Connecting a dV/dt filter with Voltage Peak Limiter for versions with two dV/dt reactors to a Motor Module Chassis-2

Cable cross-sections

Table 8- 23 Cable cross-sections for connections between the dV/dt filter plus voltage peak limiter and Motor Module

dV/dt filter plus voltage peak limiter	Connection to the DC link (DCPS/DCNS) [mm ²]	Connection between dV/dt reactor and voltage peak limiter (1U2, 1V2, 1W2) [mm ²]
Line voltage 3 AC 380 ... 480 V		
6SL3000-2DE32-6AA0	35	10
6SL3000-2DE35-0AA0	70	16
6SL3000-2DE38-4AA0	2 x 50	50
6SL3000-2DE41-4AA0	2 x 120	120
Line voltage 3 AC 500 ... 690 V		
6SL3000-2DH31-0AA0	16	6
6SL3000-2DH31-5AA0	16	6
6SL3000-2DH32-2AA0	70	16
6SL3000-2DH33-3AA0	70	16
6SL3000-2DH34-1AA0	120	35
6SL3000-2DH35-8AA0	120	35
6SL3000-2DH38-1AA0	2 x 70	70
6SL3000-2DH41-3AA0	2 x 120	120

Table 8- 24 Cable cross-sections for connections between the dV/dt filter plus Voltage Peak Limiter and Motor Module Chassis-2

dV/dt filter plus Voltage Peak Limiter	Connection to the DC link (DCP / DCN) [mm ²]	Connection between dV/dt reactor and Voltage Peak Limiter (1U2, 1V2, 1W2) [mm ²]
Line voltage 3 AC 380 ... 480 V		
6SL3000-2DE41-0AA0	2 x 120	120

 **WARNING**
Fire and device damage as a result of ground fault/short-circuit

Inadequate installation of the cables to the Motor Module DC link can result in a ground fault/short-circuit and place persons at risk as a result of the associated smoke and fire.

- Comply with local installation regulations that enable this fault to be ruled out.
- Protect the cables from mechanical damage.
- In addition, apply one of the following measures:
 - Use cables with double insulation.
 - Maintain adequate clearance, e.g. by using spacers.
 - Lay the cables in separate cable ducts or conduits.

Note**Maximum cable lengths**

The connections should be kept as short as possible.

The maximum cable length for the specified connections is 5 m in each case.

8.3.5 Dimension drawing, dV/dt reactor

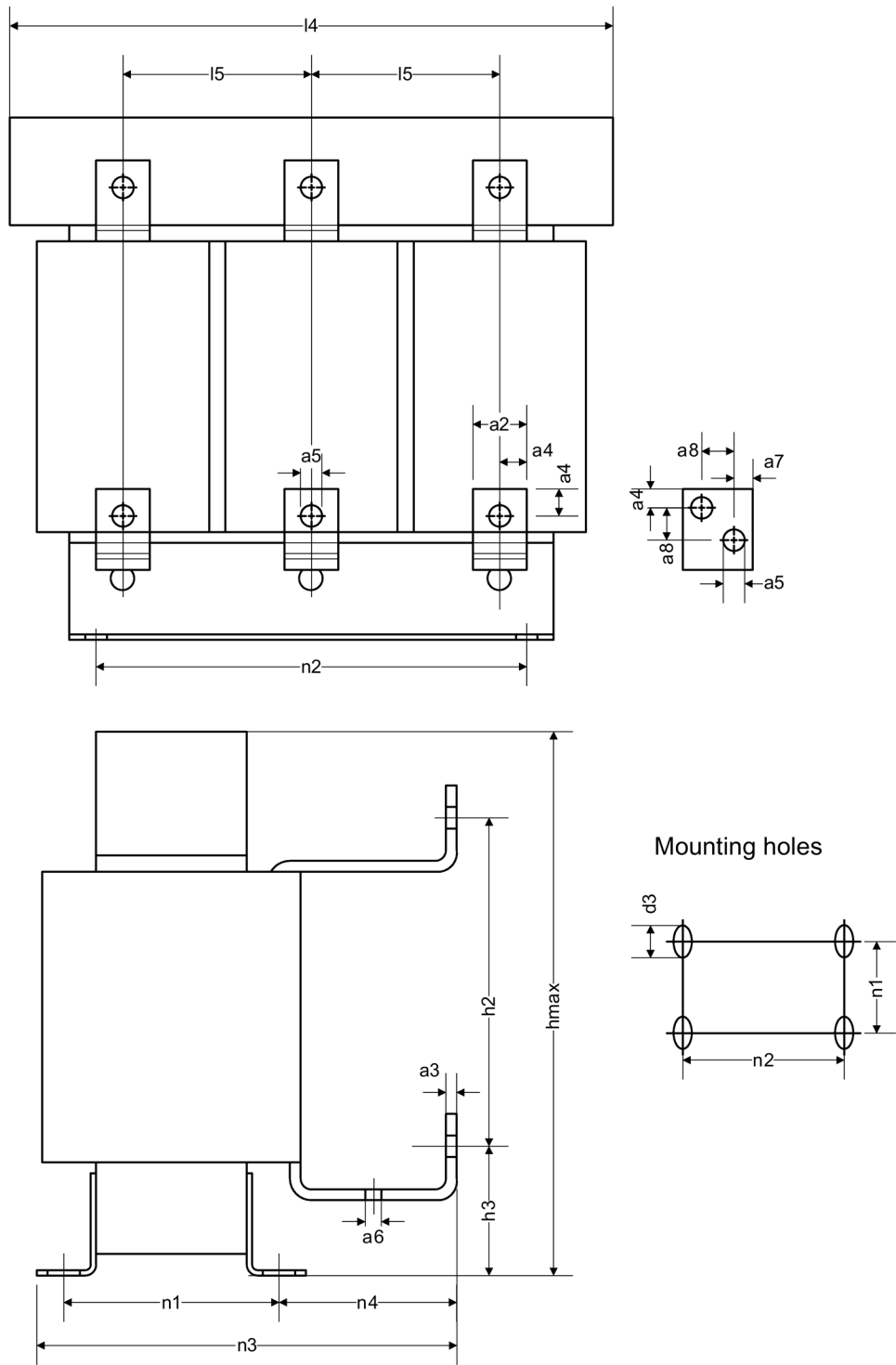

Figure 8-10 Dimension drawing, dV/dt reactor

Table 8- 25 Dimensions of dV/dt reactor, 380 V ... 480 V 3 AC (all dimensions in mm)

6SL3000-	2DE32-6CA0	2DE35-0CA0	2DE38-4CA0	2DE41-4DA0	
a2	25	30	40	60	
a3	5	6	8	10	
a4	14	17	22	19	
a5	10.5 x 14	14 x 18	14 x 18	14 x 18	
a6	7	9	11	11	
a7	-	-	-	17	
a8	-	-	-	26	
l4	410	460	460	445	
l5	135	152.5	152.5	145	
hmax	370	370	385	385	
h2	258	240	280	250	
h3	76	83	78	121	
n1 ¹⁾	141	182	212	212	
n2 ¹⁾	316	356	356	341	
n3	229	275	312	312	
n4	72	71	78	78	
d3	M10 (12 x 18)	M12 (15 x 22)	M12 (15 x 22)	M12 (15 x 22)	

¹⁾ Lengths n1 and n2 correspond to the distance between holes

Table 8- 26 Dimensions of dV/dt reactor, 500 V ... 690 V 3 AC, part 1 (all dimensions in mm)

6SL3000-	2DH31-0CA0	2DH31-5CA0	2DH32-2CA0	2DH33-3CA0	2DH34-1CA0
a2	25	25	25	25	30
a3	6	6	5	5	6
a4	14	14	14	14	17
a5	10.5 x 14	10.5 x 14	10.5 x 14	10.5 x 14	14 x 18
a6	7	7	7	9	11
a7	-	-	-	-	-
a8	-	-	-	-	-
l4	350	350	460	460	460
l5	120	120	152.5	152.5	152.5
hmax	320	320	360	360	385
h2	215	215	240	240	280
h3	70	70	86	86	83
n1 ¹⁾	138	138	155	212	212
n2 ¹⁾	264	264	356	356	356
n3	227	227	275	275	312
n4	74	74	101	42	78
d3	M8	M8	M12 (15 x 22)	M12 (15 x 22)	M12 (15 x 22)

¹⁾ Lengths n1 and n2 correspond to the distance between holes

Table 8- 27 Dimensions of dV/dt reactor, 500 V ... 690 V 3 AC, part 2 (all dimensions in mm)

6SL3000-	2DH35-8CA0	2DH38-1DA0	2DH41-3DA0		
a2	40	50	60		
a3	8	8	10		
a4	22	16	19		
a5	14 x 18	14 x 18	14 x 18		
a6	11	11	11		
a7	-	14	17		
a8	-	22	26		
l4	460	445	445		
l5	152.5	145	145		
hmax	385	385	385		
h2	280	255	250		
h3	78	114	121		
n1 ¹⁾	212	212	212		
n2 ¹⁾	356	341	341		
n3	312	312	312		
n4	78	78	78		
d3	M12 (15 x 22)	M12 (15 x 22)	M12 (15 x 22)		

¹⁾ Lengths n1 and n2 correspond to the distance between holes

8.3.6 Dimension drawing of the Voltage Peak Limiter

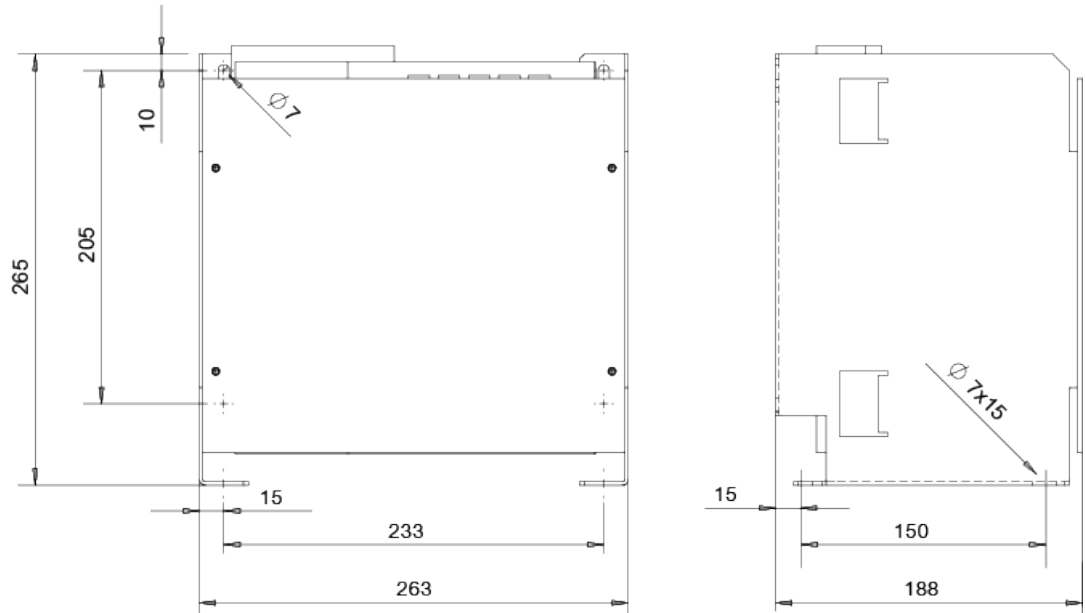

Figure 8-11 Dimension drawing of the voltage peak limiter, type 1

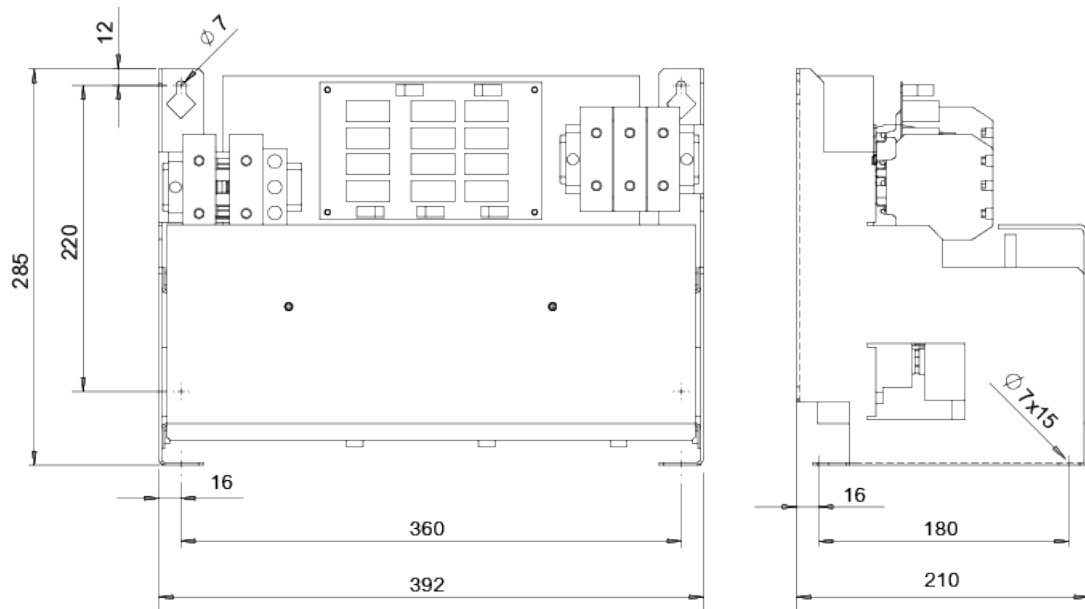

Figure 8-12 Dimension drawing of the voltage peak limiter, type 2

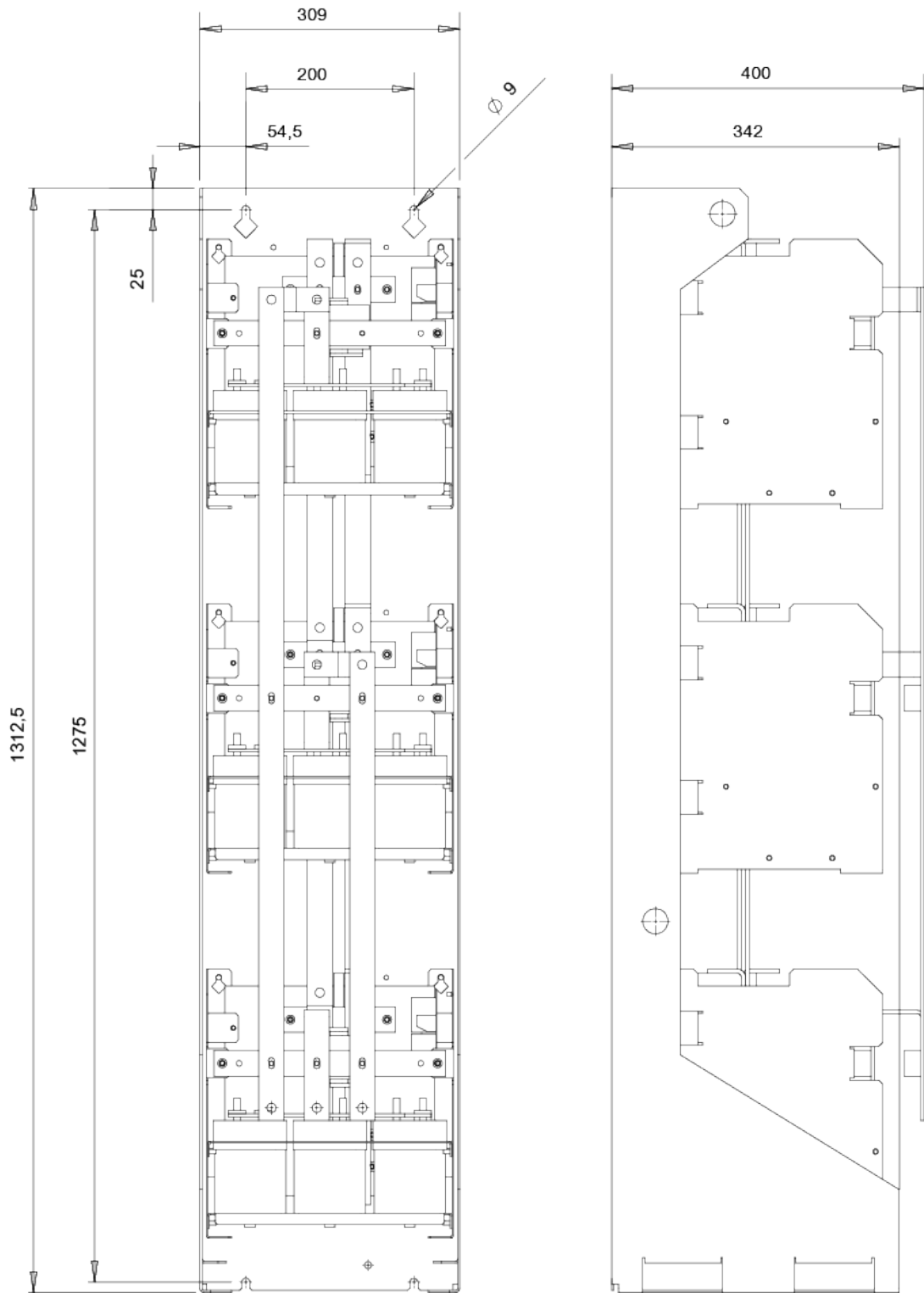

Figure 8-13 Dimension drawing of the voltage peak limiter, type 3

Table 8- 28 Assigning voltage peak limiter to dimension drawings

Voltage peak limiter	Dimension drawing type
Line voltage 3 AC 380 ... 480 V	
6SL3000-2DE32-6BA0	Type 1
6SL3000-2DE35-0BA0	Type 2
6SL3000-2DE38-4BA0	Type 3
6SL3000-2DE41-4BA0	Type 3
Line voltage 3 AC 500 ... 690 V	
6SL3000-2DH31-0BA0	Type 1
6SL3000-2DH31-5BA0	Type 1
6SL3000-2DH32-2BA0	Type 2
6SL3000-2DH33-3BA0	Type 2
6SL3000-2DH34-1BA0	Type 3
6SL3000-2DH35-8BA0	Type 3
6SL3000-2DH38-1BA0	Type 3
6SL3000-2DH41-3BA0	Type 3

8.3.7 Technical data

Table 8- 29 Technical data of the dV/dt filter plus voltage peak limiter, 3 AC 380 ... 480 V, Part 1

Article number	6SL3000-	2DE32-6AA0	2DE35-0AA0	2DE38-4AA0	2DE41-4AA0 ¹⁾
Suitable for Motor Module	6SL3320-	1TE32-1AA3 1TE32-6AA3	1TE33-1AA3 1TE33-8AA3 1TE35-0AA3	1TE36-1AA3 1TE37-5AA3 1TE38-4AA3	1TE41-0AA3 1TE41-2AA3 1TE41-4AA3 1TE41-4AS3
Type rating of the Motor Module	kW	110 / 132	160 / 200 / 250	315 / 400 / 450	560 / 710 / 800 / 800
I _{thmax}	A	260	490	840	1405
Degree of protection		IP00	IP00	IP00	IP00
dV/dt reactor					
Power loss					
- At 50 Hz	kW	0.701	0.874	1.106	1.111
- At 60 Hz	kW	0.729	0.904	1.115	1.154
- At 150 Hz	kW	0.78	0.963	1.226	1.23
Connections					
- To the Motor Module		M10	M12	M12	2 x M12
- Load		M10	M12	M12	2 x M12
- PE		M6	M6	M6	M6
Max. permissible cable length between dV/dt reactor and motor	m	300 (shielded) 450 (unshielded)			
Dimensions					
Width	mm	410	460	460	445
Height	mm	370	370	385	385
Depth	mm	229	275	312	312
Weight, approx.	kg	66	122	149	158
Voltage peak limiter					
Power loss					
- At 50 Hz	kW	0.029	0.042	0.077	0.134
- At 60 Hz	kW	0.027	0.039	0.072	0.125
- At 150 Hz	kW	0.025	0.036	0.066	0.114
Connections					
- To the dV/dt reactor		M8	Terminal 70 mm ²	M8	M10
- DC		M8	Terminal 70 mm ²	M8	M10
- PE		M8	Terminal 35 mm ²	M8	M8
Dimensions					
Width	mm	263	392	309	309
Height	mm	265	285	1312.5	1312.5
Depth	mm	188	210	400	400
Weight, approx.	kg	6	16	48	72

¹⁾ Two dV/dt reactors are required for these dV/dt filters. The technical data provided apply to one dV/dt reactor.

Note

Cable lengths for versions with two dV/dt reactors

For versions with 2 dV/dt reactors, the cable lengths specified in the table do not change.

Table 8- 30 Technical data of the dV/dt filter plus voltage peak limiter, 3 AC 380 ... 480 V, Part 2

Article number	6SL3000-	2DE41-4AA0 ¹⁾			
Matching Motor Module Chassis-2	6SL3321-	1TE41-0AA0 1TE41-1AA0 1TE41-2AA0			
Type rating of the Motor Module	kW	500 / 560 / 630			
I _{thmax}	A	1405			
Degree of protection		IP00			
dV/dt reactor					
Power loss					
- At 50 Hz	kW	1.111			
- At 60 Hz	kW	1.154			
- At 150 Hz	kW	1.23			
Connections					
- To the Motor Module		2 x M12			
- Load		2 x M12			
- PE		M6			
Max. permissible cable length between dV/dt reactor and motor	m	300 (shielded) 450 (unshielded)			
Dimensions					
Width	mm	445			
Height	mm	385			
Depth	mm	312			
Weight, approx.	kg	158			
Voltage peak limiter					
Power loss					
- At 50 Hz	kW	0.134			
- At 60 Hz	kW	0.125			
- At 150 Hz	kW	0.114			
Connections					
- To the dV/dt reactor		M10			
- DC		M10			
- PE		M8			
Dimensions					
Width	mm	309			
Height	mm	1312.5			
Depth	mm	400			
Weight, approx.	kg	72			

¹⁾ Two dV/dt reactors are required for these dV/dt filters. The technical data provided applies to one dV/dt reactor.

Note

Cable lengths for versions with two dV/dt reactors

For versions with 2 dV/dt reactors, the cable lengths specified in the table do not change.

8.3 dV/dt filter plus Voltage Peak Limiter

Table 8- 31 Technical data of the dV/dt filter plus voltage peak limiter, 3 AC 500 ... 690 V, Part 1

Article number	6SL3000-	2DH31-0AA0	2DH31-5AA0	2DH32-2AA0	2DH33-3AA0
Suitable for Motor Module	6SL3320-	1TG28-5AA3 1TG31-0AA3	1TG31-2AA3 1TG31-5AA3	1TG31-8AA3 1TG32-2AA3	1TG32-6AA3 1TG33-3AA3
Type rating of the Motor Module	kW	75 / 90	110 / 150	160 / 200	250 / 315
I_{thmax}	A	100	150	215	330
Degree of protection		IP00	IP00	IP00	IP00
dV/dt reactor					
Power loss					
- At 50 Hz	kW	0.49	0.389	0.578	0.595
- At 60 Hz	kW	0.508	0.408	0.604	0.62
- At 150 Hz	kW	0.541	0.436	0.645	0.661
Connections					
- To the Motor Module		M10	M10	M10	M10
- Load		M10	M10	M10	M10
- PE		M6	M6	M6	M6
Max. permissible cable length between dV/dt reactor and motor	m	300 (shielded) 450 (unshielded)			
Dimensions					
Width	mm	350	350	460	460
Height	mm	320	320	360	360
Depth	mm	227	227	275	275
Weight, approx.	kg	48	50	83	135
Voltage peak limiter					
Power loss					
- At 50 Hz	kW	0.016	0.020	0.032	0.042
- At 60 Hz	kW	0.015	0.019	0.03	0.039
- At 150 Hz	kW	0.013	0.018	0.027	0.036
Connections					
- To the dV/dt reactor		M8	M8	Terminal 70 mm ²	Terminal 70 mm ²
- DC		M8	M8	Terminal 70 mm ²	Terminal 70 mm ²
- PE		M8	M8	Terminal 35 mm ²	Terminal 35 mm ²
Dimensions					
Width	mm	263	263	392	392
Height	mm	265	265	285	285
Depth	mm	188	188	210	210
Weight, approx.	kg	6	6	16	16

Table 8- 32 Technical data of the dV/dt filter plus voltage peak limiter, 500 V ... 690 V 3 AC, Part 2

Article number	6SL3000-	2DH34-1AA0	2DH35-8AA0	2DH38-1AA0 ¹⁾	2DH41-3AA0 ¹⁾
Suitable for Motor Module	6SL3320-	1TG34-1AA3	1TG34-7AA3 1TG35-8AA3	1TG37-4AA3 1TG38-1AA3	1TG38-8AA3 1TG41-0AA3 1TG41-3AA3
Type rating of the Motor Module	kW	400	450 / 560	710 / 800	900 / 1000 / 1200
I _{thmax}	A	410	575	810	1270
Degree of protection		IP00	IP00	IP00	IP00
dV/dt reactor					
Power loss					
- At 50 Hz	kW	0.786	0.862	0.828	0.865
- At 60 Hz	kW	0.826	0.902	0.867	0.904
- At 150 Hz	kW	0.884	0.964	0.927	0.966
Connections					
- To the Motor Module		M12	M12	2 x M12	2 x M12
- Load		M12	M12	2 x M12	2 x M12
- PE		M6	M6	M6	M6
Max. permissible cable length between dV/dt reactor and motor	m	300 (shielded) 450 (unshielded)			
Dimensions					
Width	mm	460	460	445	445
Height	mm	385	385	385	385
Depth	mm	312	312	312	312
Weight, approx.	kg	147	172	160	164
Voltage peak limiter					
Power loss					
- At 50 Hz	kW	0.051	0.063	0.106	0.15
- At 60 Hz	kW	0.048	0.059	0.1	0.14
- At 150 Hz	kW	0.043	0.054	0.091	0.128
Connections					
- To the dV/dt reactor		M8	M8	M10	M10
- DC		M8	M8	M10	M10
- PE		M8	M8	M8	M8
Dimensions					
Width	mm	309	309	309	309
Height	mm	1312.5	1312.5	1312.5	1312.5
Depth	mm	400	400	400	400
Weight, approx.	kg	48	48	72	72

¹⁾ Two dV/dt reactors are required for these dV/dt filters. The technical data provided applies to one dV/dt reactor.

Note

Cable lengths for versions with two dV/dt reactors

For versions with 2 dV/dt reactors, the cable lengths specified in the table do not change.

8.4 dV/dt filter compact plus Voltage Peak Limiter

8.4.1 Description

The dV/dt filter compact plus voltage peak limiter comprises two components: The dV/dt reactor and the voltage-limiting network (voltage peak limiter) which cuts off the voltage peaks and feeds back the energy into the DC link. The dV/dt filter compact plus voltage peak limiter is designed for use with motors for which the voltage strength of the insulation system is unknown or insufficient.

dV/dt filters compact plus Voltage Peak Limiters limit the voltage rate of rise dV/dt to values < 1600 V/μs – and the typical voltage peaks to the following values according to limit value curve A acc. to IEC 60034-25:2007:

- < 1150 V at $U_{line} < 575$ V
- < 1400 V at 660 V < $U_{line} < 690$ V.

Note

Setting range for pulse frequencies

It is permissible to set pulse frequencies in the range between the rated pulse frequency and the relevant maximum pulse frequency when a dV/dt filter compact plus voltage peak limiter is used.

Note

Current derating at increased pulse frequency

For current derating with increased pulse frequency, the derating of the associated Motor Module is the decisive factor.

Note

Components of the dV/dt filter

The dV/dt filters compact plus voltage peak limiter of types 1 to 3 consist of a single component. Type 4 consists of two separate components, the dV/dt reactor and the voltage peak limiter.

Table 8- 33 Max. pulse frequency when a dV/dt filter compact plus voltage peak limiter is used in units with a rated pulse frequency of 2 kHz

Article number of the Motor Module 6SL3320-...	Type rating [kW]	Output current for a pulse frequency of 2 kHz [A]	Max. pulse frequency when a dV/dt filter compact plus voltage peak limiter is used
Line voltage 3 AC 380 ... 480 V			
1TE32-1AA3	110	210	4 kHz
1TE32-6AA3	132	260	4 kHz
1TE33-1AA3	160	310	4 kHz
1TE33-8AA3	200	380	4 kHz
1TE35-0AA3	250	490	4 kHz
1TE41-4AS3	800	1330	4 kHz

Table 8- 34 Max. pulse frequency when a dV/dt filter compact plus voltage peak limiter is used in units with a rated pulse frequency of 1.25 kHz

Article number of the Motor Module 6SL3320-...	Type rating [kW]	Output current for a pulse frequency of 1.25 kHz [A]	Max. pulse frequency when a dV/dt filter compact plus voltage peak limiter is used
Line voltage 3 AC 380 ... 480 V			
1TE36-1AA3	315	605	2.5 kHz
1TE37-5AA3	400	745	2.5 kHz
1TE38-4AA3	450	840	2.5 kHz
1TE41-0AA3	560	985	2.5 kHz
1TE41-2AA3	710	1260	2.5 kHz
1TE41-4AA3	800	1405	2.5 kHz
Line voltage 3 AC 500 ... 690 V			
1TG28-5AA3	75	85	2.5 kHz
1TG31-0AA3	90	100	2.5 kHz
1TG31-2AA3	110	120	2.5 kHz
1TG31-5AA3	132	150	2.5 kHz
1TG31-8AA3	160	175	2.5 kHz
1TG32-2AA3	200	215	2.5 kHz
1TG32-6AA3	250	260	2.5 kHz
1TG33-3AA3	315	330	2.5 kHz
1TG34-1AA3	400	410	2.5 kHz
1TG34-7AA3	450	465	2.5 kHz
1TG35-8AA3	560	575	2.5 kHz
1TG37-4AA3	710	735	2.5 kHz
1TG38-1AA3	800	810	2.5 kHz
1TG38-8AA3	900	910	2.5 kHz
1TG41-0AA3	1000	1025	2.5 kHz
1TG41-3AA3	1200	1270	2.5 kHz

Table 8- 35 Max. pulse frequency when a dV/dt filter compact plus Voltage Peak Limiter is used in units with a rated pulse frequency of 2.5 kHz

Article No. of the Motor Module Chassis-2 6SL3321-...	Type rating [kW]	Output current for a pulse frequency of 2.5 kHz [A]	Max. pulse frequency when a dV/dt filter compact plus Voltage Peak Limiter is used
Line voltage 3 AC 380 ... 480 V			
1TE41-0AA0	500	975	2.5 kHz
1TE41-1AA0	560	1075	2.5 kHz
1TE41-2AA0	630	1200	2.5 kHz

8.4.2 Safety information

 WARNING
Not observing fundamental safety instructions and residual risks
Not observing fundamental safety instructions and residual risks listed in Chapter 1 can result in accidents with severe injuries or death.
<ul style="list-style-type: none"> • Comply with the fundamental safety instructions. • When assessing the risk, take into account remaining risks.

 WARNING
Fire due to overheating because of inadequate ventilation clearances
Inadequate ventilation clearances can cause overheating with a risk for personnel through smoke development and fire. Furthermore, an increased number of failures and shorter service life of the components can occur.
<ul style="list-style-type: none"> • Maintain 100 mm clearances above and below the components. • Always mount the dV/dt filters compact plus Voltage Peak Limiter in a vertical, upright position to enable cooling air to flow through the heat sink on the Voltage Peak Limiter from the bottom to the top.

 CAUTION
Burns due to high surface temperature of the dV/dt filter compact
The surface temperature of the dV/dt filters compact may exceed 80 °C. You can get seriously burnt when touching the surface.
<ul style="list-style-type: none"> • Mount the dV/dt filters compact so that they cannot be touched. If this is not possible, attach a clearly visible and understandable warning notice at hazardous positions.

NOTICE**Damage to the Voltage Peak Limiter due to interchanged connections**

The Voltage Peak Limiter will be damaged if the input and output connections are interchanged on devices with the article numbers 6SL3000-2DE41-4EA0, 6SL3000-2DG38-1EA0, and 6SL3000-2DG41-3EA0.

- Connect the incoming cable from the DC link of the Motor Module to DCPS, DCNS.
- Connect the outgoing cable for the dV/dt reactor to 1U2, 1V2, 1W2.

NOTICE**Damage to the dV/dt filter compact by using components that have not been released**

When using components that have not been released, damage or malfunctions can occur at the devices or the system itself.

- Only use a dV/dt filter compact that SIEMENS has released for operation with SINAMICS.

NOTICE**Damage to the dV/dt filter compact by exceeding the maximum output frequency**

The maximum permissible output frequency when a dV/dt filter compact is used is 150 Hz. The dV/dt filter compact can be damaged if the output frequency is exceeded.

- Operate the dV/dt filter compact with a maximum output frequency of 150 Hz.

NOTICE**Damage to the dV/dt filter compact during continuous operation with low output frequencies**

Uninterrupted duty at an output frequency less than 10 Hz can result in thermal overload and destroy the dV/dt filter.

- When using a dV/dt filter compact plus voltage peak limiter do not operate the drive continuously with an output frequency less than 10 Hz.
- You may operate the drive for a maximum load duration of 5 minutes at an output frequency less than 10 Hz, provided that you then select an operation with an output frequency higher than 10 Hz for a period of 5 minutes.

NOTICE

Damage to the dV/dt filter compact by exceeding the maximum pulse frequency

The maximum permissible pulse frequency when a dV/dt filter compact is used is 2.5 kHz or 4 kHz. The dV/dt filter compact can be damaged if the pulse frequency is exceeded.

- When using the dV/dt filter compact, only operate the Motor Module with a maximum pulse frequency of 2.5 kHz or 4 kHz.

NOTICE

Damage to the dV/dt filter compact if it is not activated during commissioning

The dV/dt filter compact may be damaged if it is not activated during commissioning.

- Activate the dV/dt filter compact during commissioning using parameter p0230 = 2.

NOTICE

Damage to the dV/dt filter compact if a motor is not connected

dV/dt filters compact which are operated without a motor being connected can be damaged or destroyed.

- Never operate a dV/dt filter compact connected to the Motor Module without a connected motor.

Note

Cable lengths

Keep the connecting cables to the Motor Module as short as possible (max. 5 m). Use an equivalent cable type when replacing the cables supplied.

8.4.3 Interface description

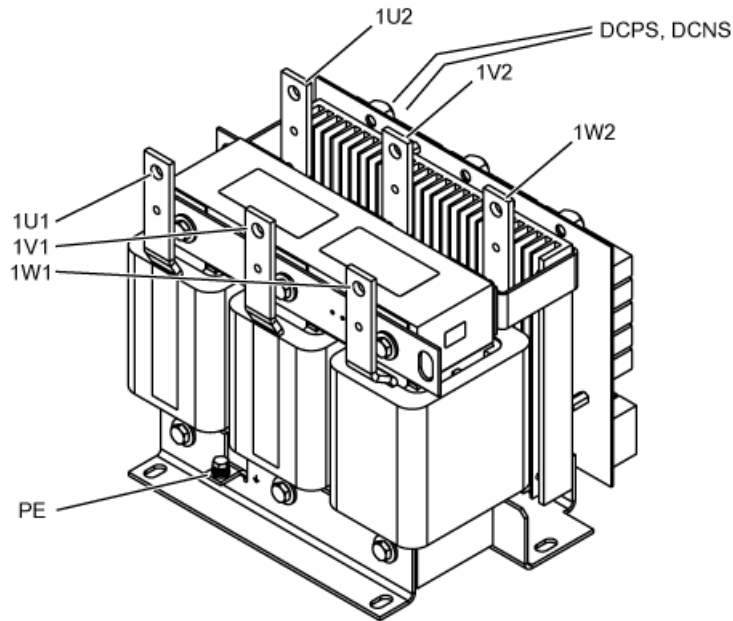

Figure 8-14 Interface overview for dV/dt filter compact plus Voltage Peak Limiter, Type 1

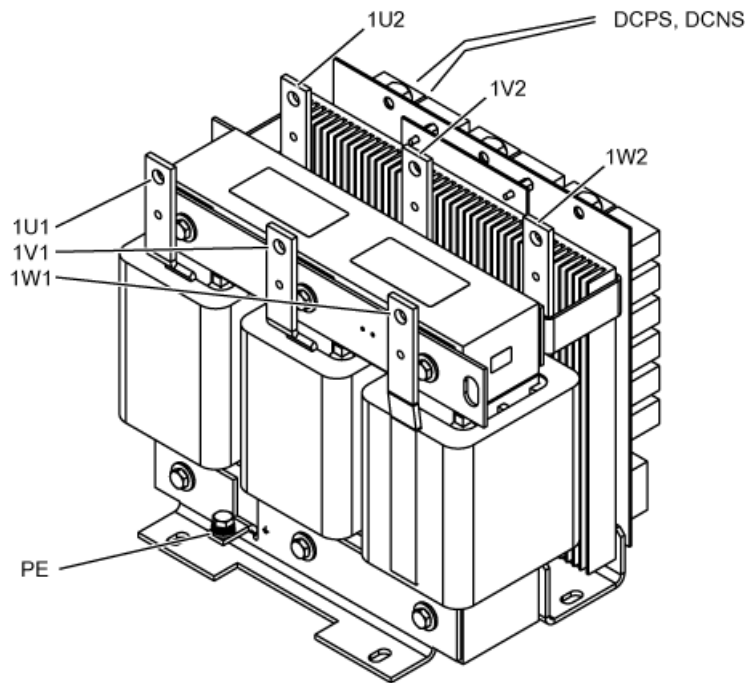

Figure 8-15 Interface overview for dV/dt filter compact plus Voltage Peak Limiter, Type 2

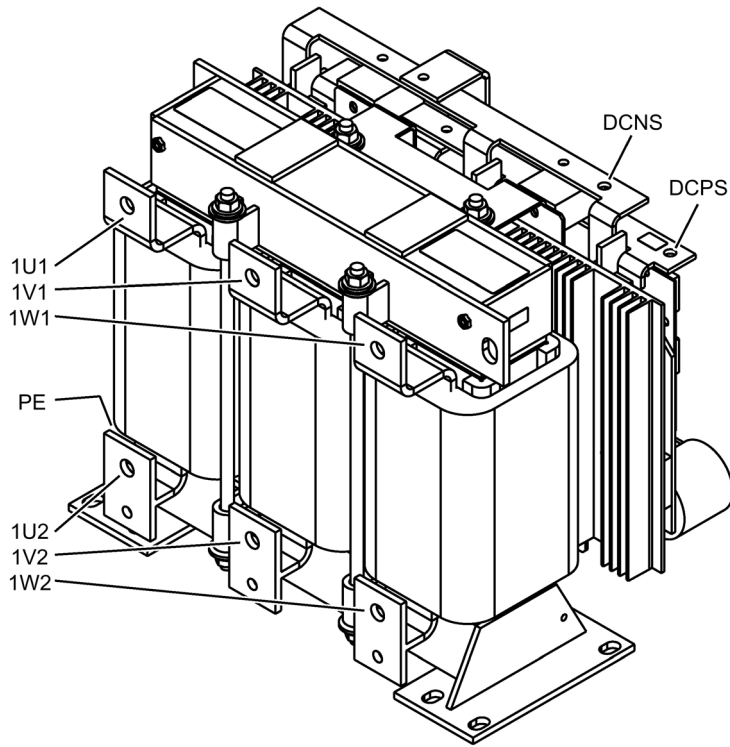

Figure 8-16 Interface overview for dV/dt filter compact plus Voltage Peak Limiter, Type 3

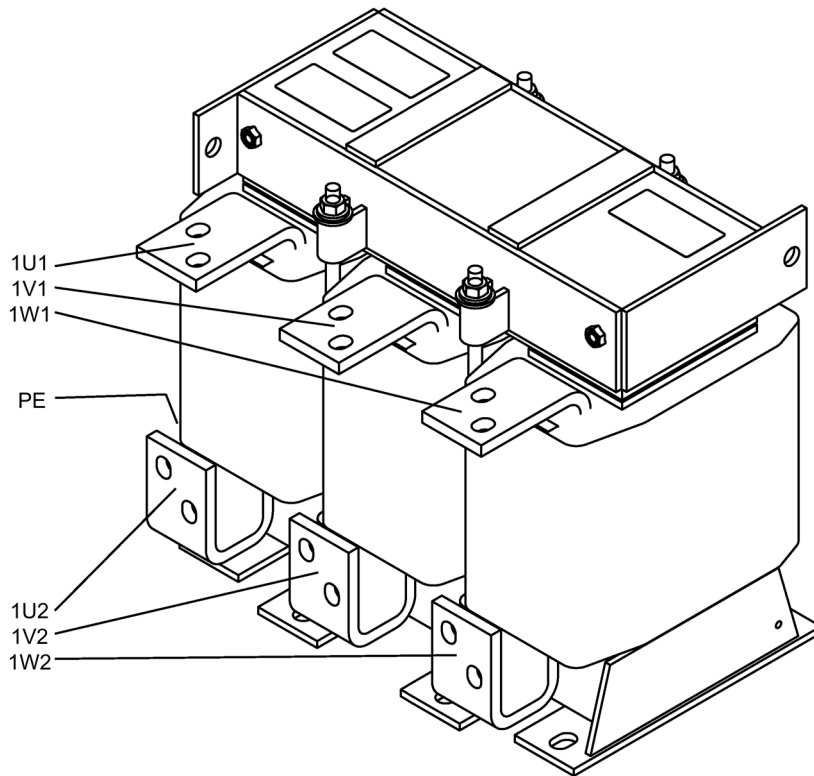

Figure 8-17 Interface overview for dV/dt filter compact plus Voltage Peak Limiter, Type 4 dV/dt reactor

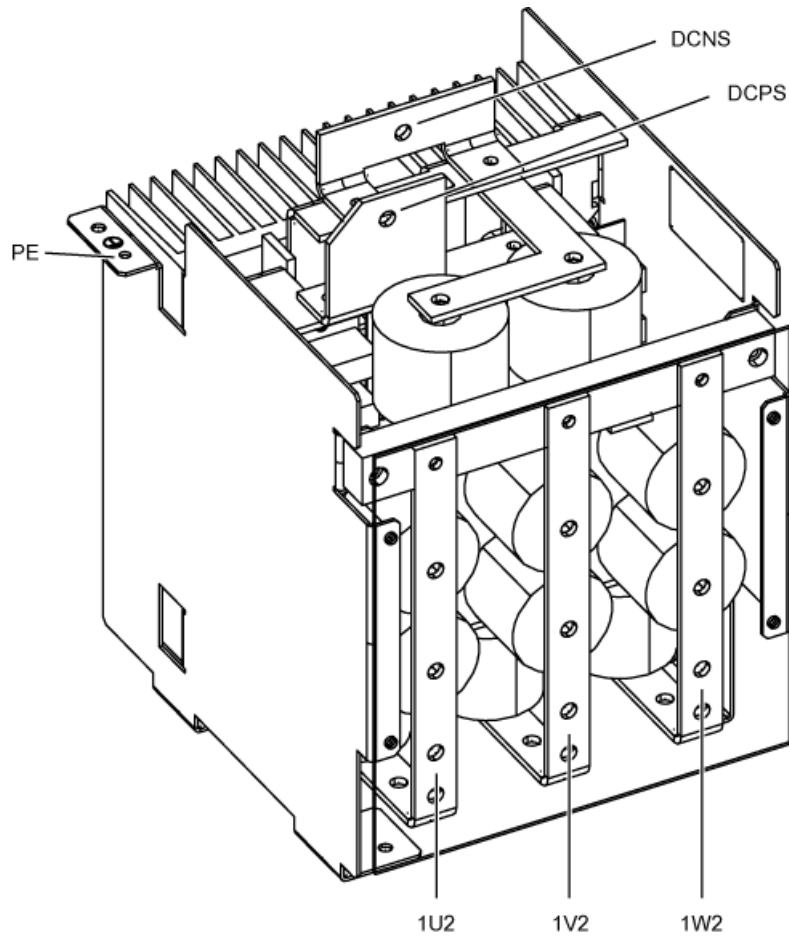

Figure 8-18 Interface overview for dV/dt filter compact plus Voltage Peak Limiter, Type 4 Voltage Peak Limiter

8.4.4 Connecting the dV/dt filter compact plus Voltage Peak Limiter

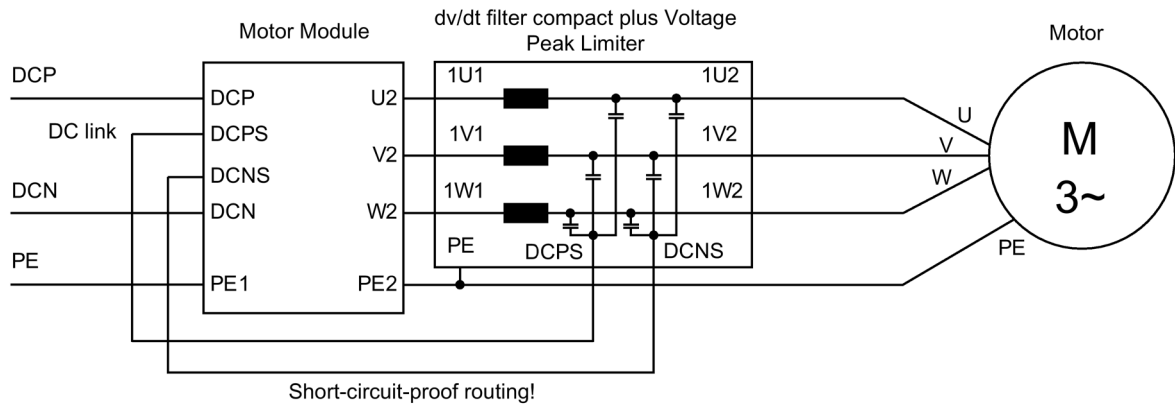

Figure 8-19 Connecting the dV/dt filter compact plus voltage peak limiter – integrated unit

8.4 dV/dt filter compact plus Voltage Peak Limiter

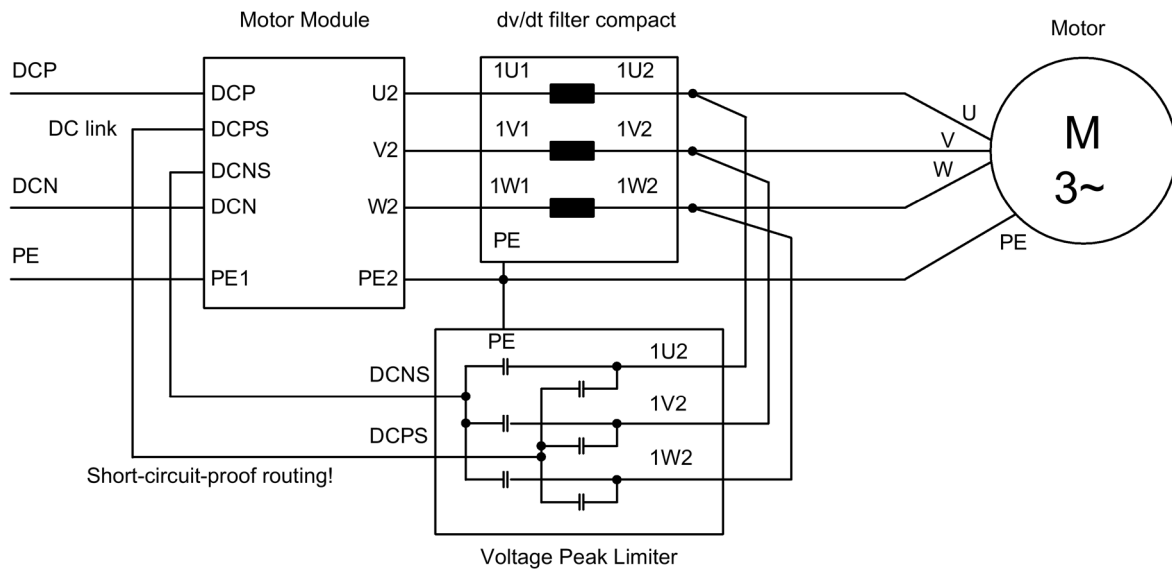

Figure 8-20 Connecting the dV/dt filter compact plus voltage peak limiter – separate components

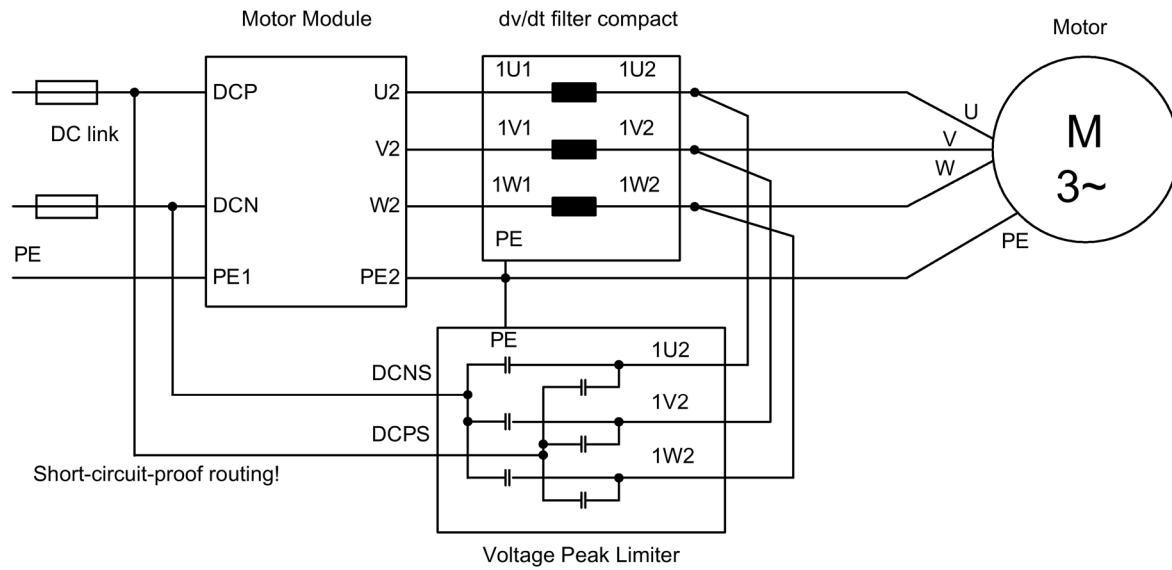

Figure 8-21 Connecting the dV/dt filter compact plus Voltage Peak Limiter to a Motor Module Chassis-2

Cable cross-sections

In a dV/dt filter with separate voltage peak limiter (type 4), the connections between dV/dt reactor and voltage peak limiter are already installed on the voltage peak limiter.

Table 8- 36 Cable cross-sections for connections between a dV/dt filter and Motor Module

dV/dt filter compact plus voltage peak limiter	Cross-section [mm ²]	Connection on dV/dt filter
Type 1	16	Screw M8 / 12 Nm
Type 2	25	Screw M8 / 12 Nm
Type 3	50	Copper bar for M8 bolt / 12 Nm
Type 4	95	Copper bar for M8 bolt / 12 Nm

Table 8- 37 Connection cable enclosed for connecting dV/dt reactor and voltage peak limiter

Voltage peak limiter	Cross-section [mm ²]	Lug for connecting 1U2 / 1V2 / 1W2 on the dV/dt reactor
Type 4	70	M12

Cable type: 600 V, UL style 3271, operating temperature 125 °C

 WARNING
<p>Fire and device damage as a result of ground fault/short-circuit</p> <p>Inadequate installation of the cables to the Motor Module DC link can result in a ground fault/short-circuit and place persons at risk as a result of the associated smoke and fire.</p> <ul style="list-style-type: none"> • Comply with local installation regulations that enable this fault to be ruled out. • Protect the cables from mechanical damage. • In addition, apply one of the following measures: <ul style="list-style-type: none"> – Use cables with double insulation. – Maintain adequate clearance, e.g. by using spacers. – Lay the cables in separate cable ducts or conduits.

<p>NOTICE</p>
<p>Damage to the dV/dt filter compact due to mechanical load on connections</p> <p>The connections at the dV/dt filter compact are not designed for direct mechanical connection to the motor cables.</p> <ul style="list-style-type: none"> • Take measures on the plant or system side to ensure that the connections cannot be deformed by the mechanical load exerted by the connected cables.

8.4.5 Dimension drawing for dV/dt filter compact plus Voltage Peak Limiter

dV/dt filter compact plus voltage peak limiter, type 1

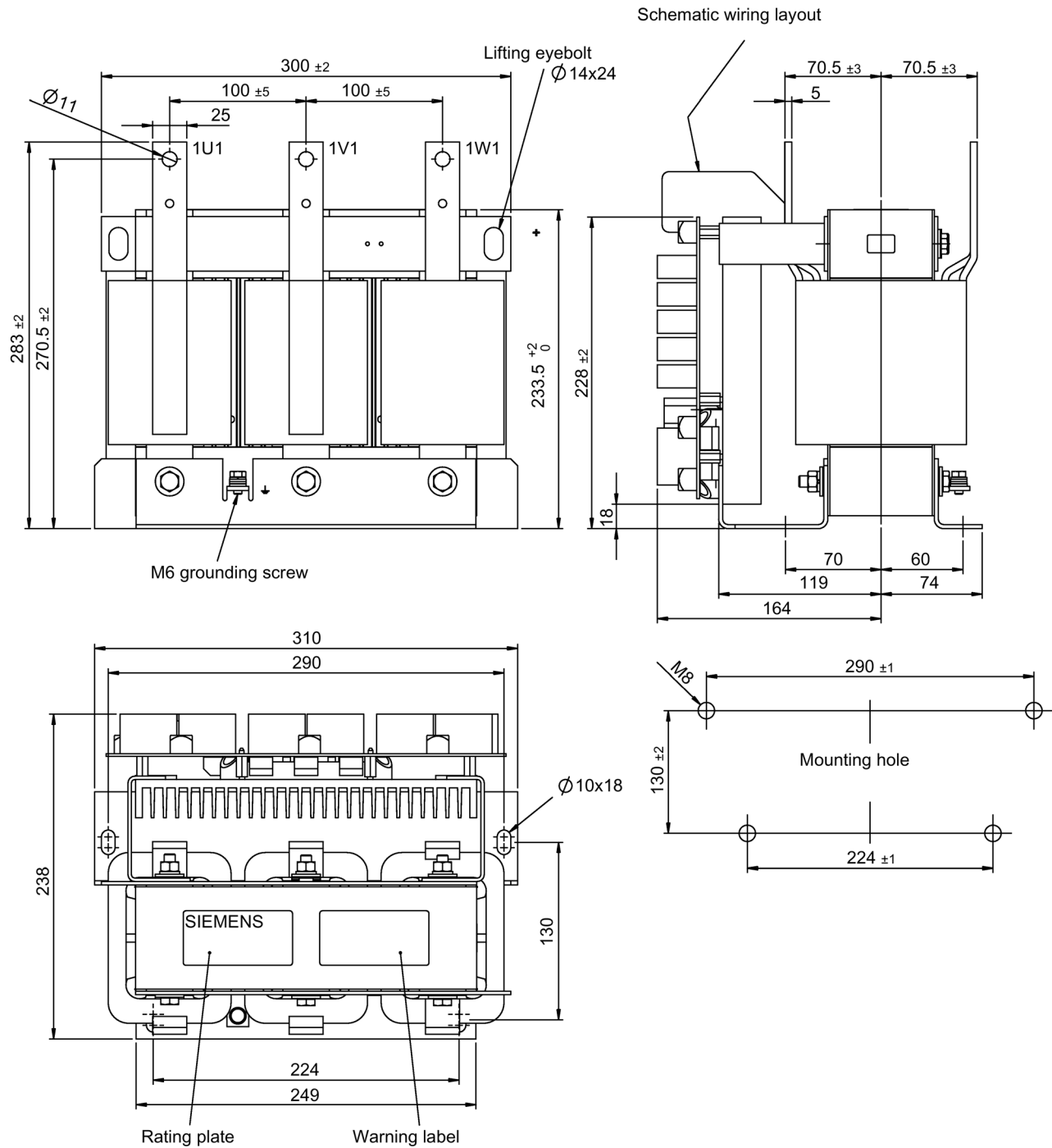

Figure 8-22 Dimension drawing for dV/dt filter compact plus voltage peak limiter, type 1

dV/dt filter compact plus voltage peak limiter, type 2

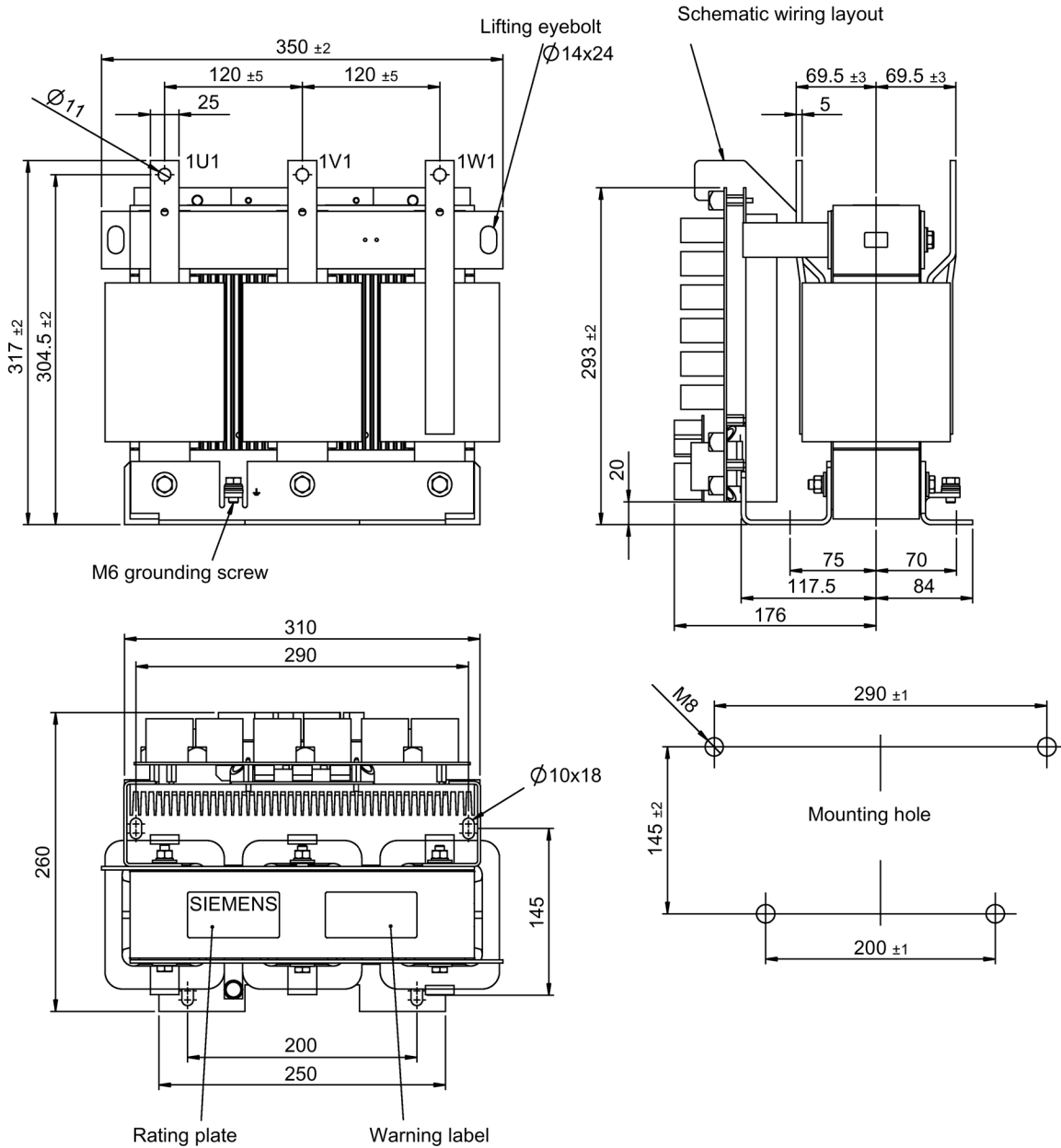

Figure 8-23 Dimension drawing for dV/dt filter compact plus voltage peak limiter, type 2

dV/dt filter compact plus voltage peak limiter, type 3

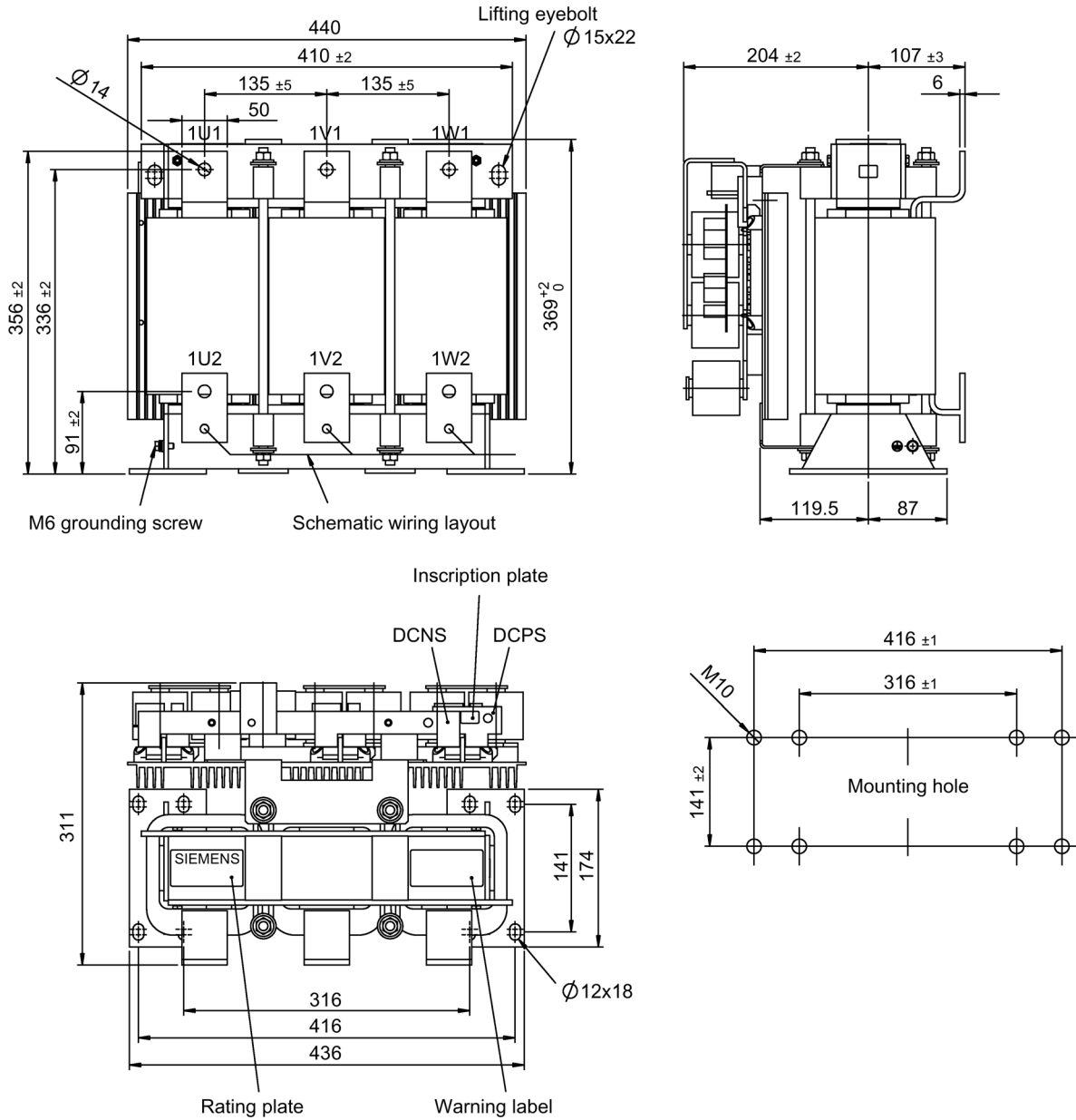

Figure 8-24 Dimension drawing for dV/dt filter compact plus voltage peak limiter, type 3

dV/dt filter compact plus voltage peak limiter, type 4

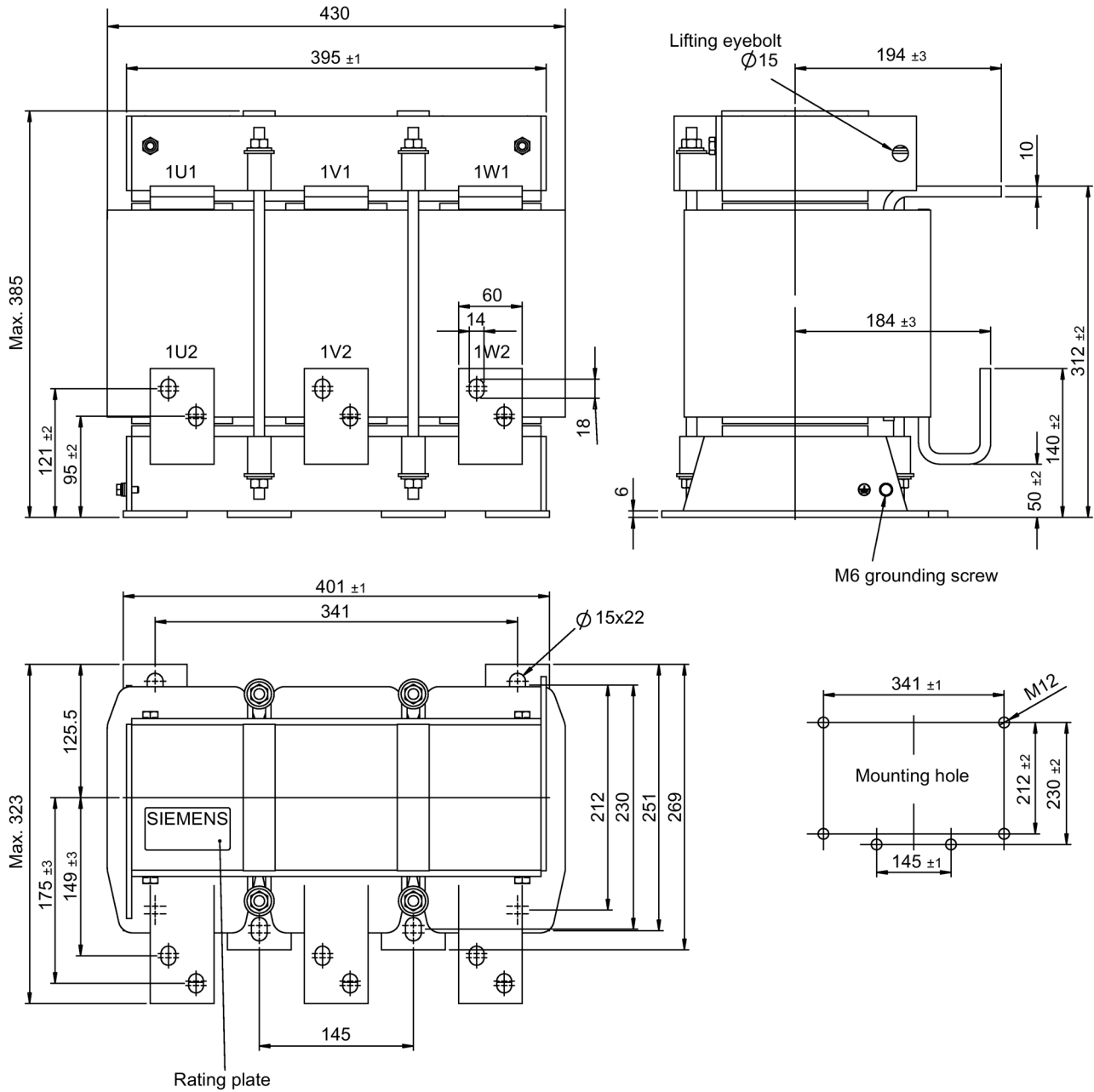

Figure 8-25 Dimension drawing for dV/dt filter compact plus voltage peak limiter, type 4 dV/dt reactor

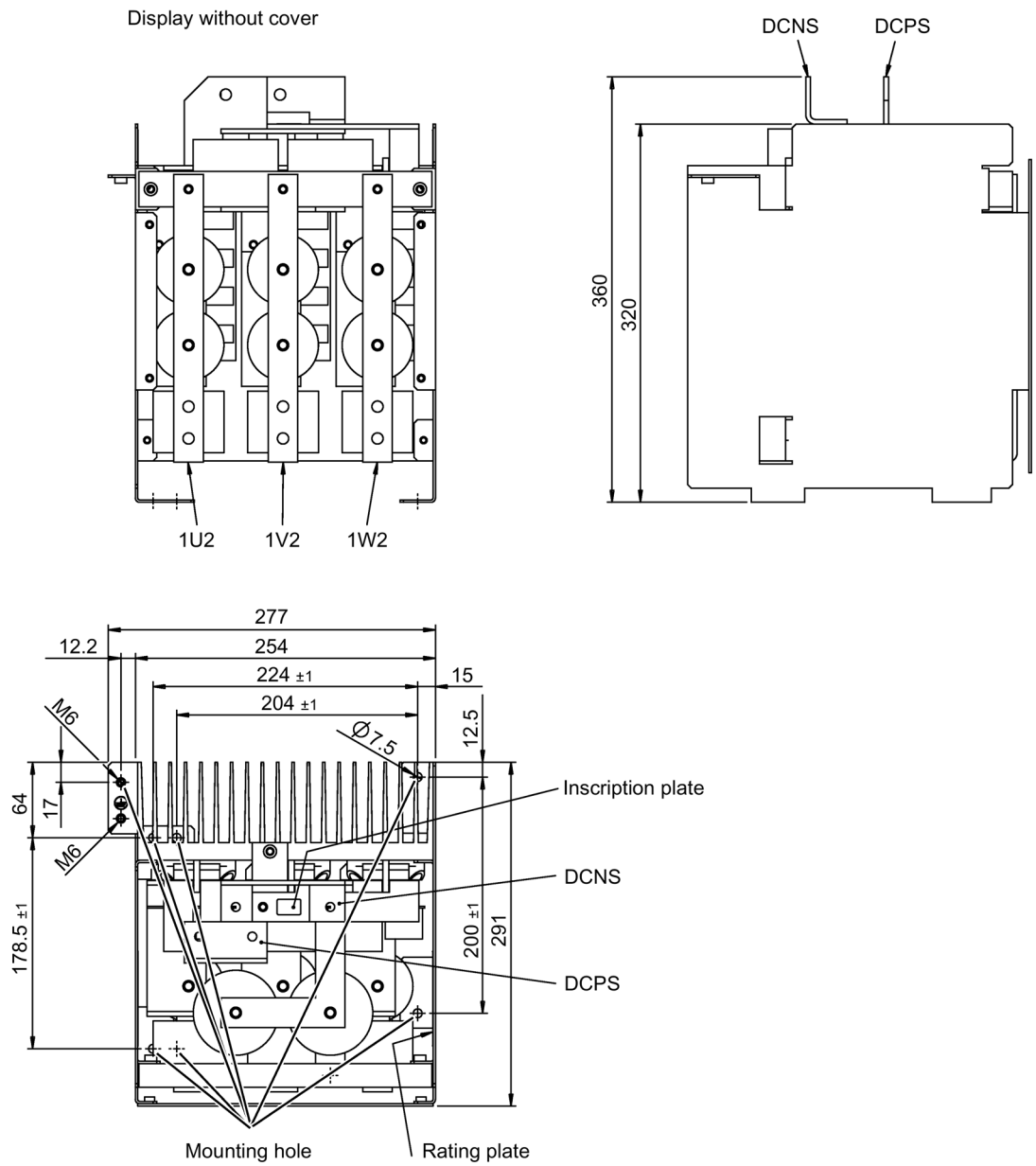

Figure 8-26 Dimension drawing for dV/dt filter compact plus voltage peak limiter, type 4 Voltage peak limiter

Table 8- 38 Assignment of dV/dt filters compact plus voltage peak limiter to the dimension drawings

dV/dt filter compact plus voltage peak limiter	Dimension drawing type
Line voltage 3 AC 380 ... 480 V	
6SL3000-2DE32-6EA0	Type 1
6SL3000-2DE35-0EA0	Type 2
6SL3000-2DE38-4EA0	Type 3
6SL3000-2DE41-4EA0	Type 4
Line voltage 3 AC 500 ... 690 V	
6SL3000-2DG31-0EA0	Type 1
6SL3000-2DG31-5EA0	Type 1
6SL3000-2DG32-2EA0	Type 2
6SL3000-2DG33-3EA0	Type 2
6SL3000-2DG34-1EA0	Type 3
6SL3000-2DG35-8EA0	Type 3
6SL3000-2DG38-1EA0	Type 4
6SL3000-2DG41-3EA0	Type 4

8.4.6 Technical data

Table 8- 39 Technical data of the dV/dt filter compact plus voltage peak limiter, 380 V ... 480 V 3 AC, Part 1

Article number	6SL3000-	2DE32-6EA0	2DE35-0EA0	2DE38-4EA0
Suitable for Motor Module (unit rating)	6SL3320-	1TE32-1AA3 (110 kW) 1TE32-6AA3 (132 kW)	1TE33-1AA3 (160 kW) 1TE33-8AA3 (200 kW) 1TE35-0AA3 (250 kW)	1TE36-1AA3 (315 kW) 1TE37-5AA3 (400 kW) 1TE38-4AA3 (450 kW)
I_{thmax}	A	260	490	840
Degree of protection		IP00	IP00	IP00
Power loss				
- at 50 Hz	kW	0.210	0.290	0.518
- at 60 Hz	kW	0.215	0.296	0.529
- at 150 Hz	kW	0.255	0.344	0.609
Terminals				
- 1U1/1V1/1W1		for M10 bolt	for M10 bolt	for M12 bolt
- DCPS/DCNS		for M8 screw	for M8 screw	for M8 bolt
- 1U2/1V2/1W2		for M10 bolt	for M10 bolt	for M12 bolt
- PE		M6 screw	M6 screw	M6 screw
Max. permissible cable length between dV/dt filter and motor	m	100 (shielded) 150 (unshielded)		
Dimensions				
Width	mm	310	350	440
Height	mm	283	317	369
Depth	mm	238	260	311
Weight, approx.	kg	41	61	103

Table 8- 40 Technical data of the dV/dt filter compact plus voltage peak limiter, 380 V ... 480 V 3 AC, Part 2

Article number	6SL3000-	2DE41-4EA0		
Suitable for Motor Module (unit rating)	6SL3320-	1TE41-0AA3 (560 kW) 1TE41-2AA3 (710 kW) 1TE41-4AA3 (800 kW) 1TE41-4AS3 (800 kW)		
I _{thmax}	A	1405		
Degree of protection		IP00		
Power loss				
- At 50 Hz	kW	1.154		
- At 60 Hz	kW	1.197		
- At 150 Hz	kW	1.444		
Max. permissible cable length between dV/dt filter and motor	m		100 (shielded) 150 (unshielded)	
dV/dt reactor				
Terminals - 1U1/1V1/1W1 - 1U2/1V2/1W2 - PE		for 2 x M12 bolts for 2 x M12 bolts M6 screw		
Dimensions				
Width	mm	430		
Height	mm	385		
Depth	mm	323		
Weight, approx.	kg	168.8		
Voltage peak limiter				
Terminals - DCPS/DCNS - 1U2/1V2/1W2 - PE		for M8 bolt for M8 bolt for M6 screw		
Dimensions				
Width	mm	277		
Height	mm	360		
Depth	mm	291		
Weight, approx.	kg	19.2		

Table 8- 41 Technical data of the dV/dt filter compact plus voltage peak limiter, 380 V ... 480 V 3 AC, Part 3

Article number	6SL3000-	2DE41-4EA0		
Matching Motor Module Chassis-2 (type rating)	6SL3321-	1TE41-0AA0 (500 kW) 1TE41-1AA0 (560 kW) 1TE41-2AA0 (630 kW)		
I_{thmax}	A	1405		
Degree of protection		IP00		
Power loss - at 50 Hz - at 60 Hz - at 150 Hz	kW kW kW	1.154 1.197 1.444		
Max. permissible cable length between dV/dt filter and motor	m		100 (shielded) 150 (unshielded)	
dV/dt reactor				
Terminals - 1U1/1V1/1W1 - 1U2/1V2/1W2 - PE		for 2 x M12 bolts for 2 x M12 bolts M6 screw		
Dimensions Width Height Depth	mm mm mm	430 385 323		
Weight, approx.	kg	168.8		
Voltage Peak Limiter				
Terminals - DCPS/DCNS - 1U2/1V2/1W2 - PE		for M8 bolt for M8 bolt for M6 screw		
Dimensions Width Height Depth	mm mm mm	277 360 291		
Weight, approx.	kg	19.2		

Table 8- 42 Technical data of the dV/dt filter compact plus voltage peak limiter, 500 V ... 690 V 3 AC, Part 1

Article number	6SL3000-	2DG31-0EA0	2DG31-5EA0	2DG32-2EA0
Suitable for Motor Module (unit rating)	6SL3320-	1TG28-5AA3 (75 kW) 1TG31-0AA3 (90 kW)	1TG31-2AA3 (110 kW) 1TG31-5AA3 (132 kW)	1TG31-8AA3 (160 kW) 1TG32-2AA3 (200 kW)
I_{thmax}	A	100	150	215
Degree of protection		IP00	IP00	IP00
Power loss				
- at 50 Hz	kW	0.227	0.270	0.305
- at 60 Hz	kW	0.236	0.279	0.316
- at 150 Hz	kW	0.287	0.335	0.372
Terminals				
- 1U1/1V1/1W1		for M10 bolt	for M10 bolt	for M10 bolt
- DCPS/DCNS		for M8 screw	for M8 screw	for M8 screw
- 1U2/1V2/1W2		for M10 bolt	for M10 bolt	for M10 bolt
- PE		M6 screw	M6 screw	M6 screw
Max. permissible cable length between dV/dt filter and motor	m	100 (shielded) 150 (unshielded)		
Dimensions				
Width	mm	310	310	350
Height	mm	283	283	317
Depth	mm	238	238	260
Weight, approx.	kg	34	36	51

Table 8- 43 Technical data of the dV/dt filter compact plus voltage peak limiter, 500 V ... 690 V 3 AC, Part 2

Article number	6SL3000-	2DG33-3EA0	2DG34-1EA0	2DG35-8EA0
Suitable for Motor Module (unit rating)	6SL3320-	1TG32-6AA3 (250 kW) 1TG33-3AA3 (315 kW)	1TG34-1AA3 (400 kW)	1TG34-7AA3 (450 kW) 1TG35-8AA3 (560 kW)
I_{thmax}	A	330	410	575
Degree of protection		IP00	IP00	IP00
Power loss				
- at 50 Hz	kW	0.385	0.550	0.571
- at 60 Hz	kW	0.399	0.568	0.586
- at 150 Hz	kW	0.480	0.678	0.689
Terminals				
- 1U1/1V1/1W1		for M10 bolt	for M12 bolt	for M12 bolt
- DCPS/DCNS		for M8 screw	for M8 bolt	for M8 bolt
- 1U2/1V2/1W2		for M10 bolt	for M12 bolt	for M12 bolt
- PE		M6 screw	M6 screw	M6 screw
Max. permissible cable length between dV/dt filter and motor	m	100 (shielded) 150 (unshielded)		
Dimensions				
Width	mm	350	440	440
Height	mm	317	369	369
Depth	mm	260	311	311
Weight, approx.	kg	60	87	100

Table 8- 44 Technical data of the dV/dt filter compact plus voltage peak limiter, 500 V ... 690 V 3 AC, Part 3

Article number	6SL3000-	2DG38-1EA0	2DG41-3EA0	
Suitable for Motor Module (unit rating)	6SL3320-	1TG37-4AA3 (710 kW) 1TG38-1AA3 (800 kW)	1TG38-8AA3 (900 kW) 1TG41-0AA3 (1000 kW) 1TG41-3AA3 (1200 kW)	
I_{thmax}	A	810	1270	
Degree of protection		IP00	IP00	
Power loss				
- at 50 Hz	kW	0.964	1.050	
- at 60 Hz	kW	0.998	1.104	
- at 150 Hz	kW	1.196	1.319	
Max. permissible cable length between dV/dt filter and motor	m	100 (shielded) 150 (unshielded)		
dV/dt reactor				
Terminals				
- 1U1/1V1/1W1		for 2 x M12 bolts	for 2 x M12 bolts	
- 1U2/1V2/1W2		for 2 x M12 bolts	for 2 x M12 bolts	
- PE		M6 screw	M6 screw	
Dimensions				
Width	mm	430	430	
Height	mm	385	385	
Depth	mm	323	323	
Weight, approx.	kg	171.2	175.8	
Voltage Peak Limiter				
Terminals				
- DCPS/DCNS		for M8 bolt	for M8 bolt	
- 1U2/1V2/1W2		for M8 bolt	for M8 bolt	
- PE		for M6 screw	for M6 screw	
Dimensions				
Width	mm	277	277	
Height	mm	360	360	
Depth	mm	291	291	
Weight, approx.	kg	18.8	19.2	

Cabinet design and EMC

9.1 Information

9.1.1 General

The modular concept of SINAMICS S120 chassis units allows a wide range of potential device combinations. For this reason, it is impossible to describe each individual combination. This section instead aims to provide some basic information and general rules on the basis of which special device combinations can be configured to ensure electro-magnetic compatibility and adequate cooling – therefore ensuring reliable operation with the appropriate functionality.

SINAMICS S120 components are designed for installation in the appropriate enclosures, which can take the form of cabinet units or control boxes made of steel that provide protection against shock and other environmental effects. They are also part of the EMC concept.

9.1.2 Safety information

 WARNING
Not observing fundamental safety instructions and residual risks
Not observing fundamental safety instructions and residual risks listed in Chapter 1 can result in accidents with severe injuries or death.
<ul style="list-style-type: none">• Comply with the fundamental safety instructions.• When assessing the risk, take into account remaining risks.

 WARNING
Injuring caused by foreign objects in the device
Parts and components falling into the device (e.g. drilling chips, end sleeves, etc.) can cause short-circuits and damage to the insulation. This can lead to serious injuries (arcing, bangs, pieces flying out of the equipment).
<ul style="list-style-type: none">• Only perform installation and other work when the devices are current-free.• Cover the ventilation slits during the installation of the cabinet and remove the cover before switching on.

NOTICE
Limiting of overvoltages
On systems with a grounded phase conductor and a line voltage >600 V AC, line-side components should be installed to limit overvoltages to overvoltage category II according to IEC 61800-5-1.

Note

Protection against the spread of fire

The converter may be operated only in closed housings or in higher-level control cabinets with protective covers that are closed, and when all of the protective devices are used.

Converters of the Open Type/IP20 degree of protection must be installed in a metal control cabinet or protected by another equivalent measure such that fire cannot spread and emissions outside of the control cabinet are prevented.

Note

Protection against condensation and electrically conductive contamination

To ensure functional safety and safety functions of Safety Integrated, protect the converter, e.g. by installing it in a control cabinet with degree of protection IP54 according to IEC 60529 or Type 12 according to NEMA 250. Further measures may be necessary for particularly critical operating conditions.

A lower degree of cabinet protection is permissible, if condensation and conductive pollution can be excluded at the installation site.

Maximum cable lengths

Table 9- 1 Maximum cable lengths

Type	Maximum length [m]
24 V DC power cables ¹⁾	10
24 V signal cables ¹⁾	30
Power cable between the Motor Module and motor when using two motor reactors in series	300 (shielded) 450 (unshielded) 525 (shielded) 787 (unshielded)
Power cable between the Motor Module Chassis-2 and motor when using 2 motor reactors in series	300 (shielded) 450 (unshielded) 450 (shielded) 675 (unshielded)
DRIVE-CLiQ cables	70
<ul style="list-style-type: none"> • Inside the electrical cabinet, e.g. connection between the CU320 and the first Motor Module or between the Motor Modules • DRIVE-CLiQ MOTION-CONNECT connecting cables for external components 	100
Power cable between Braking Module and braking resistor	100

¹⁾ For longer lengths, suitable wiring must be provided by the user for overvoltage protection.

Table 9- 2 Recommendations for overvoltage protection

DC supply	24 V signal cables
Weidmüller Type: PU DS 24 V Order number: 8682100000	Weidmüller Type no.: MCZ OVP TAZ 24 V Order number: 8449160000
Weidmüller GmbH & Co. KG	

9.1.3 Directives

The control cabinet must satisfy the following EC Directives in the European Economic Area (EEA):

Table 9- 3 Directives

Directive	Description
2014/35/EU	Directive of the European Parliament and Council from February 26, 2014 on the approximation of the laws relating to the provision of electrical equipment designed for use within certain voltage limits (Low-Voltage Directive)
2014/30/EU	Directive of the European Parliament and Council of February 26, 2014 for the harmonization of the laws of the member states relating to electromagnetic compatibility (EMC directive)
2006/42/EC	Directive of the European Parliament and Council of May 17, 2006 on machinery and for changing Directive 95/16/EC (amendment) (machinery directive)

9.2 EMC-compliant design and control cabinet configuration

Detailed configuration instructions regarding the EMC-compliant design of drives and control cabinet configuration can be found in the "SINAMICS Low Voltage Configuration Manual", see Configuration Manual for SINAMICS G130, G150, S120 Built-in Units, S120 Cabinet Modules, S150 (<https://support.industry.siemens.com/cs/ww/de/view/83180185>).

9.3 Cabinet air conditioning

9.3.1 General

The minimum dimensions listed below for ventilation clearances must be observed. No other components or cables may be installed in or laid through these areas.

NOTICE
Device failure caused by overloading of devices and components
If the guidelines for installing SINAMICS S120 Chassis devices are not observed, this can significantly reduce the service life of the components. This can result in premature device and component failure.
<ul style="list-style-type: none">Observe the guidelines for installing the devices and components.

You must take into account the following specifications when using a SINAMICS S120 Chassis drive line-up:

- Ventilation clearance
- Cabling
- Air guidance

Table 9- 4 Ventilation clearances for the components

Component	Frame size	Clearance at the front [mm]	Clearance (above) [mm]	Clearance (below) [mm]	Clearance at the side [mm]
Basic Line Module	FB, GB, GD	40 ¹⁾	250	150	0
Active Interface Module	FI	40 ¹⁾	250	150	0
Active Interface Module	GI	50 ¹⁾	250	150	0
Active Interface Module	HI, JI	40 ¹⁾	250	0	0
Smart Line Module	GX, HX, JX	40 ¹⁾	250	150	0
Active Line Module	FX, GX, HX, JX	40 ¹⁾	250	150	0
Motor Module	FX, GX, HX, JX	40 ¹⁾	250	150	0
Motor Module Chassis-2	FS4	0	200	0	80 (clearance to the right) ²⁾

¹⁾ The clearances refer to the area around the ventilation slots on the front cover.

²⁾ The clearances refer to the area around the air intake of the fan and the upper ventilation slots in the lateral cover.

Note

Notes on the dimensions

The dimensions refer to the outer edges of the devices.

Dimension drawings are available in the relevant chapters.

9.3.2 Ventilation

The SINAMICS S120 Chassis devices are forced-ventilated by means of integrated fans. To ensure an adequate air supply, suitably large openings for the inlet intake (e.g. ventilation slots in the cabinet door) and discharged air (e.g. by means of a roof canopy) must be provided.

The cooling air must flow through the components vertically from bottom (cooler region) to top (region heated by operation).

You must ensure that the air is flowing in the right direction. You must also ensure that the warm air can escape at the top. The specified ventilation clearances must be observed.

Note

Cables must not be routed directly on the components. The ventilation grilles must not be covered.

Cold air must not be allowed to blow directly onto electronic equipment.

NOTICE

Device failure due to condensation as a result of unsuitable air guidance and cooling

Unsuitable air guidance and cooling equipment can cause condensation, which can result in device failure.

- Choose air guidance measures, as well as the arrangement of and settings for the cooling equipment in such a way as to prevent condensation even with the highest relative humidity.
- If required, install cabinet enclosure heating.

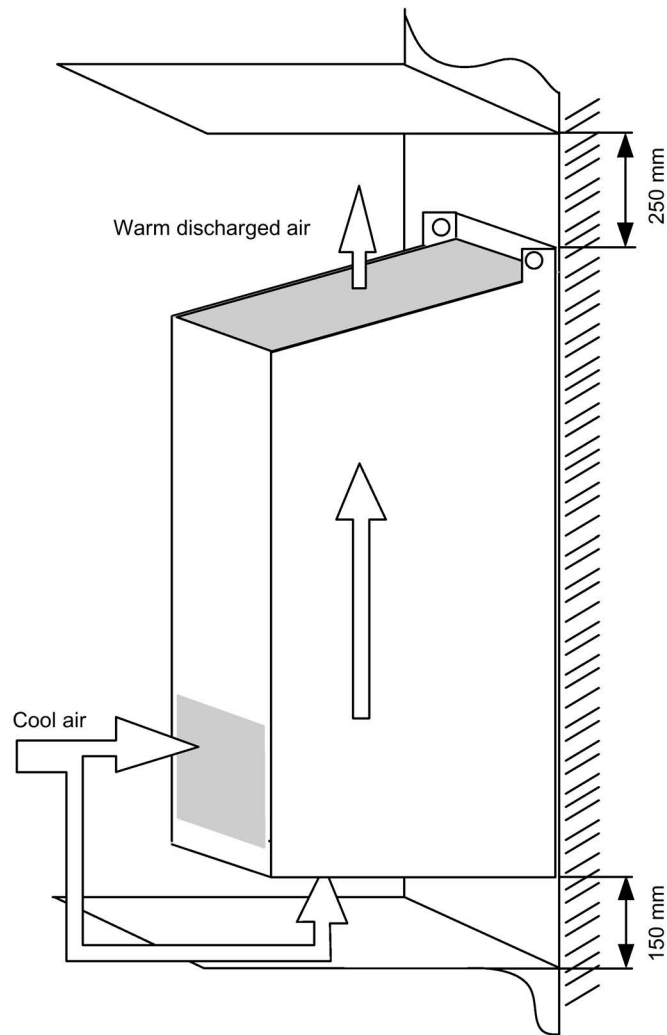

Figure 9-1 Air guidance for Active Interface Module, frame sizes FI, GI

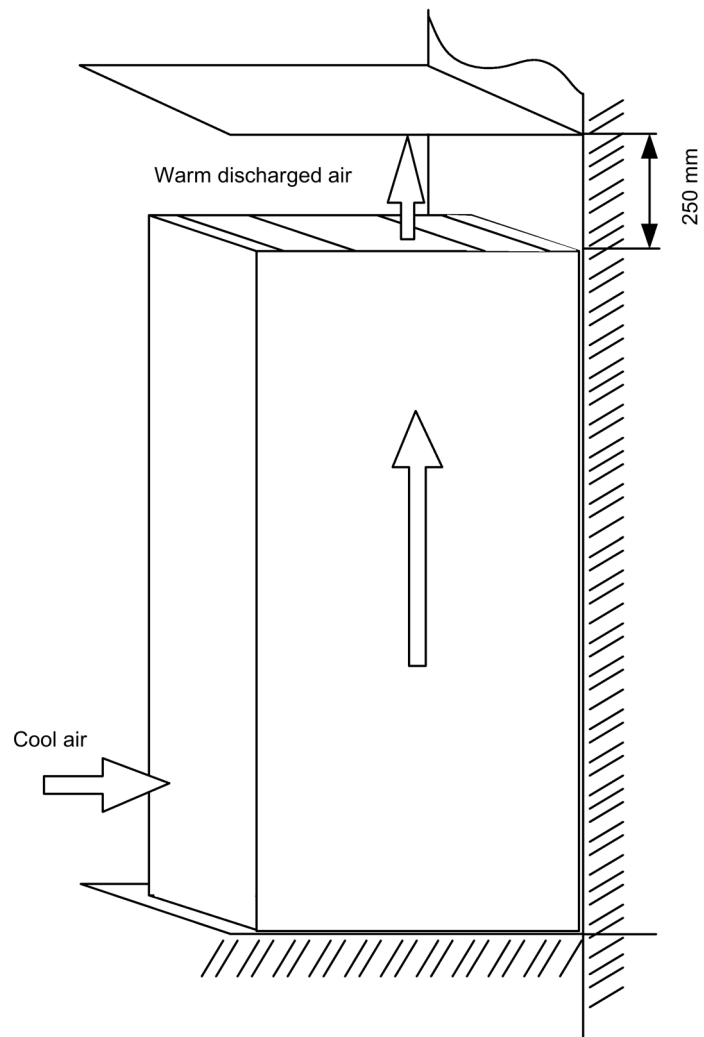

Figure 9-2 Air guidance for Active Interface Module, frame sizes HI, JI

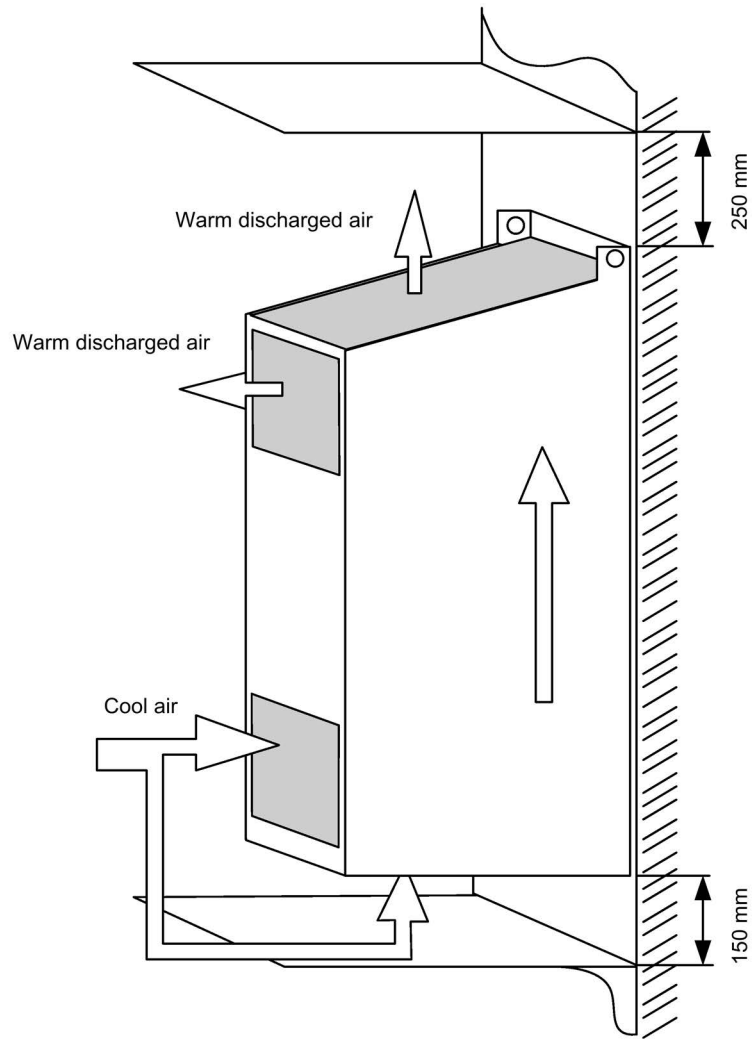

Figure 9-3 Air guidance for Smart Line Module, Active Line Module, Motor Module, frame sizes FX, GX

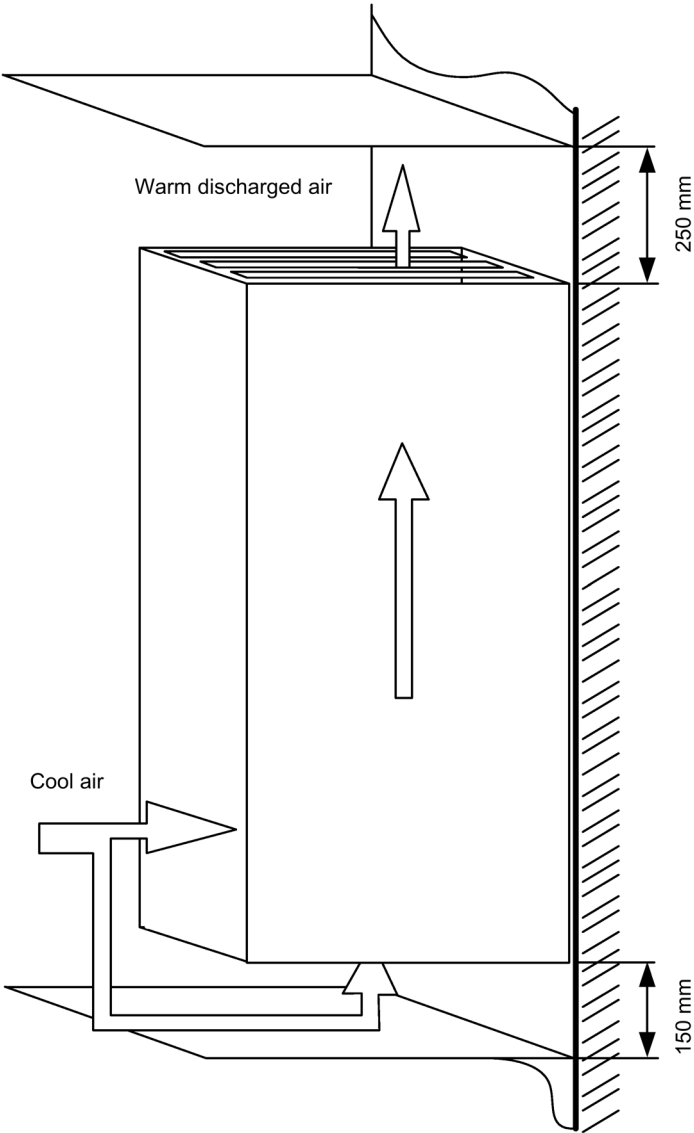

Figure 9-4 Air guidance for Smart Line Module, Active Line Module, Motor Module, frame sizes HX, JX

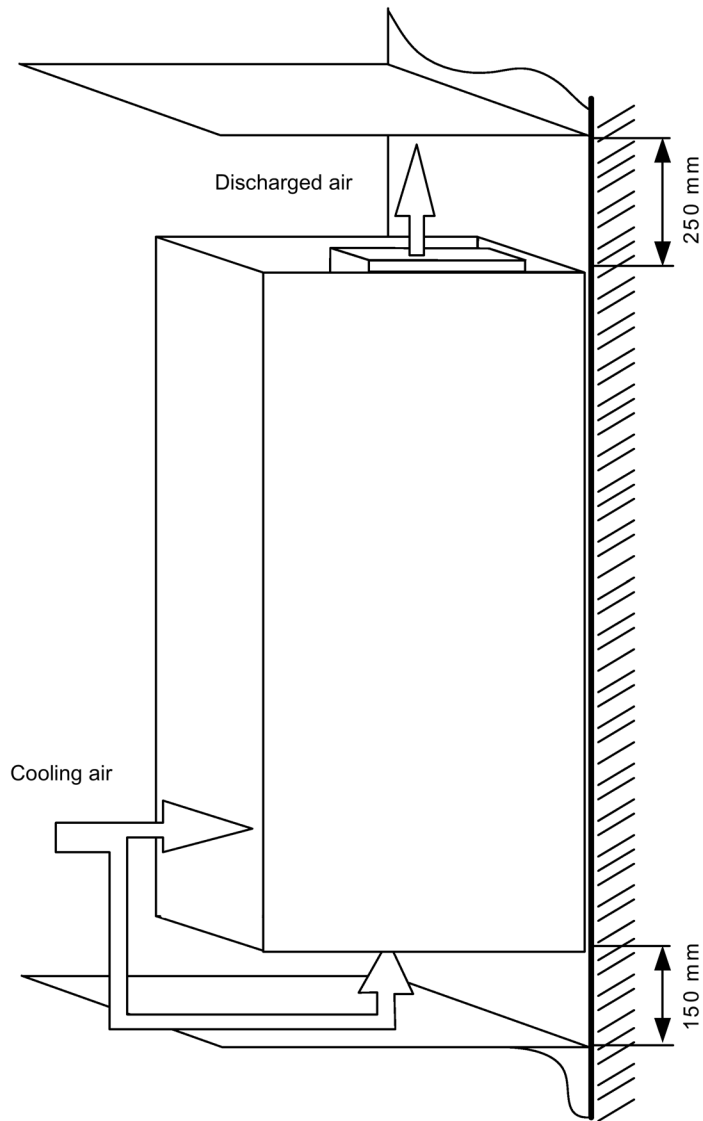

Figure 9-5 Air guidance for Basic Line Module, frame sizes FB, GB, GD

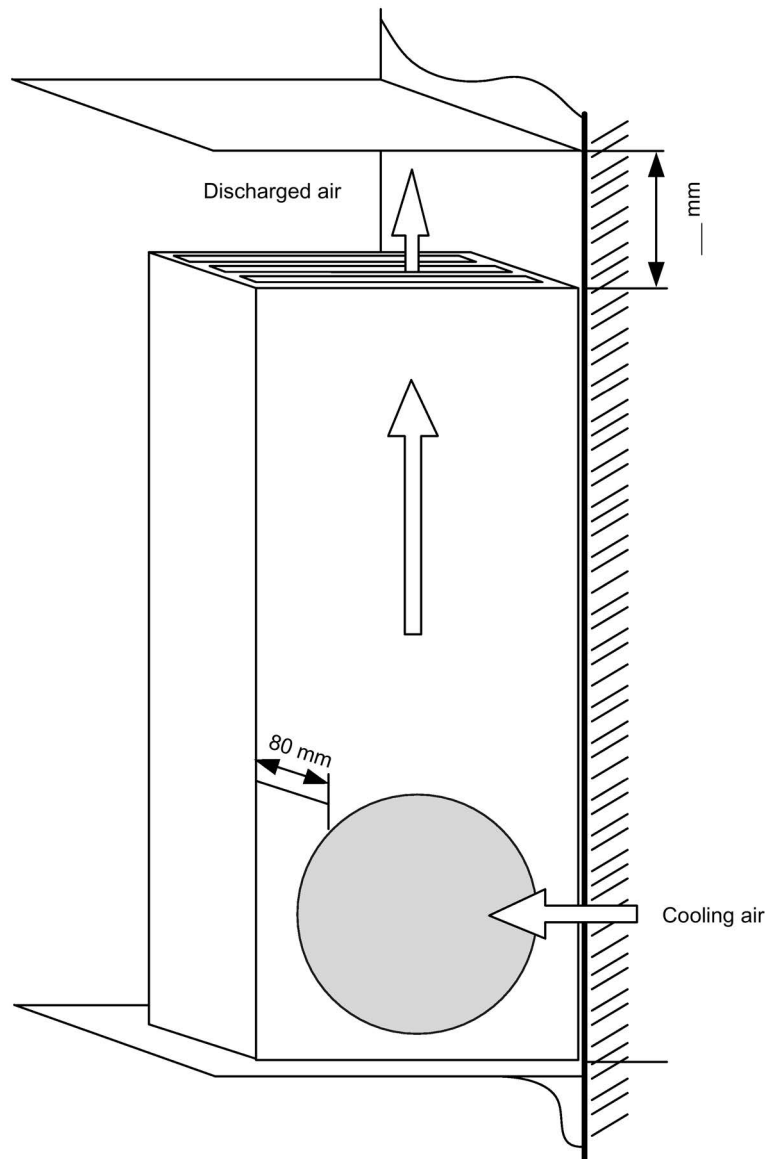

Figure 9-6 Air guidance for Motor Modules Chassis-2, frame size FS4

Devices must not be operated in an "air short-circuit", since this can damage equipment or cause it to fail.

The drawn air of the fan causes negative pressure to build up at the ventilation openings in the cabinet doors. The pressure is dependent on the volume flow rate and the hydraulic cross-section of the openings.

The air, which blows out of the top of the device, accumulates under the top cover/hood, resulting in overpressure.

The difference between the overpressure at the top of the cabinet and the negative pressure at the bottom creates a flow of air (air short-circuit). This can vary in strength depending on the cross-section of the door and cover openings and the volumetric flow of the fan.

Due to the flow of air within the cabinet, the device fan draws in pre-heated air. This heats up the components considerably and the fan does not function effectively.

NOTICE

Device failure due to air short-circuit in the control cabinet

Short-circuits in the cooling air circuit as a result of unsuitable air guidance can result in overheating in the electrical cabinet and in turn failure of devices.

- Install suitable barriers in the control cabinet in order to prevent an air short-circuit from occurring.

NOTICE

Failure of devices as a result of the different cooling concepts of the Chassis and Chassis-2 power units

When using Chassis and Chassis-2 power units in one electrical cabinet, if suitable partitions are not used, then the devices can fail as a result of the different cooling concepts.

- Install suitable partitions between the cabinet panels where Chassis and Chassis-2 power units are mounted.

Barriers must be installed in such a way that no air can flow along the outer sides on the top and bottom of the devices. In particular, air must be prevented from flowing from the top (warm discharged air) to the bottom (cold cooling air). Suitable plates can be used as barriers. The barriers must reach up to the side panels or cabinet doors. They must be set up in such a way that the outgoing air current is not forced into the cabinet cross-beams, but is instead diverted around them. Barriers must be in place for all degrees of protection higher than IP20.

The cabinets adjacent to the converter cabinets must also be taken into account when barriers are installed.

To ensure adequate ventilation of the equipment, the minimum opening sizes specified in the following table must be observed.

The specified opening cross-sections comprise several small openings. To ensure that pressure loss is kept to a minimum and that the flow resistance does not become too great at these mesh-type openings, the cross sectional area of each opening must be around at least 190 mm² (e.g. 7.5 mm x 25 mm or 9.5 mm x 20 mm).

To ensure that the devices operate continuously, suitable measures must be taken to prevent the ingress of dirt and dust. Wire lattices (wire fabric DIN 4189-St-vzk-1x0.28) or filter mats (min. filter class G2) must be used for this purpose. The choice of filter mats depends on the required degree of protection and the ambient conditions. If cabinets are installed in an environment containing fine dust particles or oil vapors, micro-filter mats must be used to prevent the devices from becoming contaminated.

If dirt filters are used, the specified opening cross-sections and the filter areas must be adjusted upwards.

NOTICE

Device failure due to overheating as a result of contaminated dirt filters

Contaminated filter mats cause the device to overheat and fail.

- If dirt filters are used, observe the specified replacement intervals.

If the filter mats are heavily contaminated, the volume of air drawn is reduced due to the increased flow resistance. This can cause the fans integrated in the devices to overload, or it could cause the devices themselves to overheat and become damaged.

The opening cross-sections specified in the table refer in each case to one device. If more than one device is installed in a cabinet, the opening cross-section increases accordingly. If the required openings cannot be made in the cabinet, the devices must be distributed across several cabinets which are separated from each other by means of partitions.

The warm air must be discharged via the top cover/hood or via side openings in the cabinet at the level of the device top. The size of the opening cross-section must also be taken into account here.

With degrees of protection higher than IP20 and if a hood is used, it may be necessary to use an "active" hood. An "active" hood contains fans that blow the air current forwards. The hood is closed, with the exception of the air outlet point.

If you choose an "active" hood, you must ensure that the fans are sufficiently powerful to prevent air from accumulating in the cabinet. If air accumulates, the cooling capacity is reduced. This can overheat and destroy the devices. The air capacity of the fans should at least be equivalent to the device fan data.

9.3 Cabinet air conditioning

Table 9- 5 Volume flow rate, opening cross-sections

Active Interface Modules						
Article number	6SL3300-	7TE32-6AA0	7TE33-8AA0 7TE35-0AA0	7TE38-4AA0 7TE41-4AA0 7TG35-8AA0 7TG37-4AA0 7TG41-3AA0		
Cooling air requirement	[m³/s]	0.24	0.47	0.4		
Min. opening cross-section in cabinet inlet	[m²]	0.1	0.25	0.2		
outlet	[m²]	0.1	0.25	0.2		
Basic Line Modules						
Article number	6SL3330-	1TE34-2AA3 1TE35-3AA3 1TE38-2AA3 1TG33-0AA3 1TG34-3AA3 1TG36-8AA3	1TE41-2AA3 1TE41-5AA3 1TE41-6AA3 1TG41-1AA3 1TG41-4AA3 1TG41-8AA3			
Cooling air requirement	[m³/s]	0.17	0.36			
Min. opening cross-section in cabinet inlet	[m²]	0.1	0.19			
outlet	[m²]	0.1	0.19			
Smart Line Modules						
Article number	6SL3330-	6TE35-5AA3 6TE37-3AA3 6TG35-5AA3	6TE41-1AA3 6TG38-8AA3	6TE41-3AA3 6TE41-7AA3 6TG41-2AA3 6TG41-7AA3		
Cooling air requirement	[m³/s]	0.36	0.78	1.08		
Min. opening cross-section in cabinet inlet	[m²]	0.19	0.28	0.38		
outlet	[m²]	0.19	0.28	0.38		

Active Line Modules						
Article number	6SL3330-	7TE32-1AA3	7TE32-6AA3	7TE33-8AA3 7TE35-0AA3	7TE36-1AA3 7TE37-5AA3 7TE38-4AA3	7TE41-0AA3 7TE41-2AA3 7TE41-4AA3 7TG37-4AA3 7TG41-0AA3 7TG41-3AA3
Cooling air requirement	[m³/s]	0.17	0.23	0.36	0.78	1.08
Min. opening cross-section in cabinet inlet	[m²]	0.1	0.1	0.19	0.28	0.38
outlet	[m²]	0.1	0.1	0.19	0.28	0.38
Motor Modules						
Article number	6SL3320-	1TE32-1AA3 1TG28-5AA3 1TG31-0AA3 1TG31-2AA3 1TG31-5AA3	1TE32-6AA3	1TE33-1AA3 1TE33-8AA3 1TE35-0AA3 1TG31-8AA3 1TG32-2AA3 1TG32-6AA3 1TG33-3AA3	1TE36-1AA3 1TE37-5AA3 1TE38-4AA3 1TG34-1AA3 1TG34-7AA3 1TG35-8AA3	1TE41-0AA3 1TE41-2AA3 1TE41-4AA3 1TE41-4AS3 1TG37-4AA3 1TG38-1AA3 1TG38-8AA3 1TG41-0AA3 1TG41-3AA3
Cooling air requirement	[m³/s]	0.17	0.23	0.36	0.78	1.08
Minimum cross-section of the air intake opening in the electrical cabinet	[m²]	0.1	0.1	0.19	0.28	0.38
Air discharge opening	[m²]	0.1	0.1	0.19	0.28	0.38
Motor Modules Chassis-2						
Article number	6SL3321-				1TG41-0AA0 1TG41-1AA0 1TG41-2AA0	
Cooling air requirement	[m³/s]				0.64	
Min. opening cross-section in cabinet inlet	[m²]				0.38	
outlet	[m²]				0.28	

Maintenance and Servicing

10.1 Chapter content

This chapter provides information on the following:

- Maintenance and servicing procedures that have to be carried out on a regular basis to ensure the availability of the components.
- Exchanging device components when the unit is serviced
- Forming the DC-link capacitors

WARNING

Not observing fundamental safety instructions and residual risks

Not observing fundamental safety instructions and residual risks listed in Chapter 1 can result in accidents with severe injuries or death.

- Comply with the fundamental safety instructions.
- When assessing the risk, take into account remaining risks.

WARNING

Electric shock from external supply voltages

When the external power supply or the external 230 V AC auxiliary supply is connected, dangerous voltages are still present in components even when the main switch is open.

Contact with live parts can result in death or serious injury.

- Switch off external supply voltages and external 230 V AC auxiliary supply before opening the device.

10.2 Maintenance

The devices comprise mostly electronic components. Apart from the fan(s), therefore, they contain hardly any components that are subject to wear or that require maintenance or servicing. Maintenance is intended to ensure that the equipment remains in the specified condition. Dirt and contamination must be removed regularly and parts subject to wear replaced.

The following points must generally be observed.

Cleaning

Dust deposits

Dust deposits inside the device must be removed at regular intervals (or at least once a year) by qualified personnel in line with the relevant safety regulations. The unit must be cleaned using a brush and vacuum cleaner, and dry compressed air (max. 1 bar) for areas that cannot be easily reached.

Ventilation

The ventilation openings in the devices must never be obstructed. The fans must be checked to make sure that they are functioning correctly.

Cable and screw terminals

Cable and screw terminals must be checked regularly to ensure that they are secure in position, and if necessary, retightened. Cabling must be checked for defects. Defective parts must be replaced immediately.

Note

Maintenance intervals

The actual intervals at which maintenance procedures are to be performed depend on the installation conditions (cabinet environment) and the operating conditions.

Siemens offers its customers support in the form of a service contract. For further details, contact your regional office or sales office.

10.3 Maintenance

Servicing involves activities and procedures for maintaining and restoring the specified condition of the devices.

Required tools

The following tools are required for replacing components:

- Standard set of tools with screwdrivers, screw wrenches, socket wrenches, etc.
- Torque wrenches 1.5 Nm up to 100 Nm
- 600 mm extension for socket wrenches

Tightening torques for screw connections

The following tightening torques apply when tightening current-conducting connections (DC link connections, motor connections, busbars, lugs) and other connections (ground connections, protective conductor connections, steel threaded connections).

Table 10- 1 Tightening torques for screw connections

Thread	Ground connections, protective conductor connections, steel threaded connections	Aluminum threaded connections, plastic, busbars, lugs
M3	1.3 Nm	0.8 Nm
M4	3 Nm	1.8 Nm
M5	6 Nm	3 Nm
M6	10 Nm	6 Nm
M8	25 Nm	13 Nm
M10	50 Nm	25 Nm
M12	88 Nm	50 Nm
M16	215 Nm	115 Nm

Note

Screw connections for protective covers

The threaded connections for the protective covers made of Makrolon may only be tightened with 2.5 Nm.

10.3.1 Installation device

Description

The installation device is used for installing and removing the power blocks for the Basic Line Modules, Smart Line Modules, Active Line Modules, and Motor Modules in chassis format.

The mounting equipment cannot be used for Motor Modules Chassis-2.

It is used as a mounting aid and is placed in front of and secured to the module. The telescopic rails allow the withdrawable device to be adjusted according to the height at which the power blocks are installed. Once the mechanical and electrical connections have been undone, the power block can be removed from the module, whereby the power block is guided and supported by the guide rails on the withdrawable devices.



Figure 10-1 Installation device

Article number

The article number for the installation device is 6SL3766-1FA00-0AA0.

10.3.2 Using crane lifting lugs to transport power blocks

Crane lifting lugs

The power blocks are fitted with crane lifting lugs for transportation on a lifting harness in the context of replacement.

The positions of the crane lifting lugs are illustrated by arrows in the figures below.

NOTICE

Damage to the device due to improper transport

Improper transport can cause mechanical loads on the power block housing or the busbars, which result in damage to the device.

- When transporting the power blocks, use a lifting harness with vertical ropes or chains.
- Do not use the power block busbars to support or secure lifting harnesses.

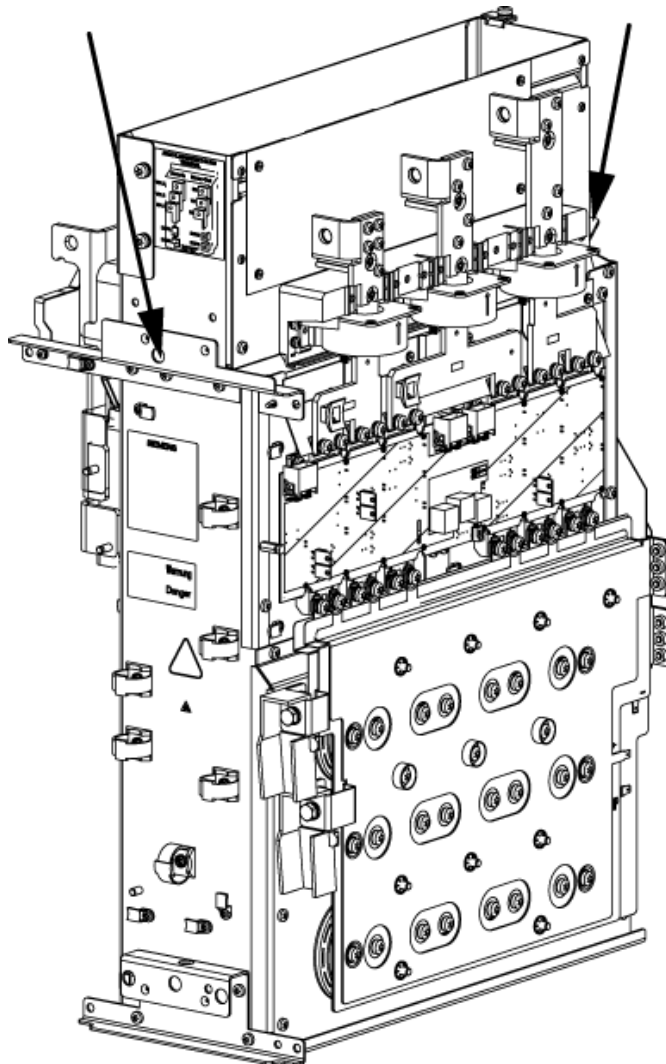

Figure 10-2 Crane lifting lugs on power block frame size FX, GX, FB

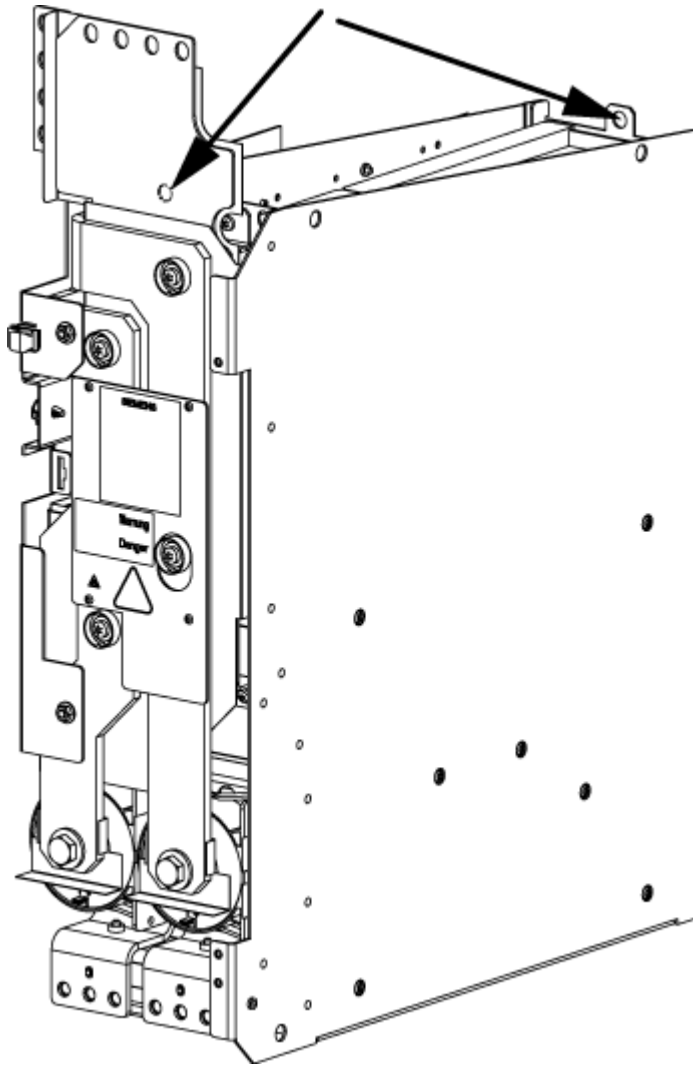

Figure 10-3 Crane lifting lugs on HX, JX power block

Note

Crane lifting lugs on HX, JX power block

On HX and JX power blocks, the front crane lifting lug is located behind the busbar.

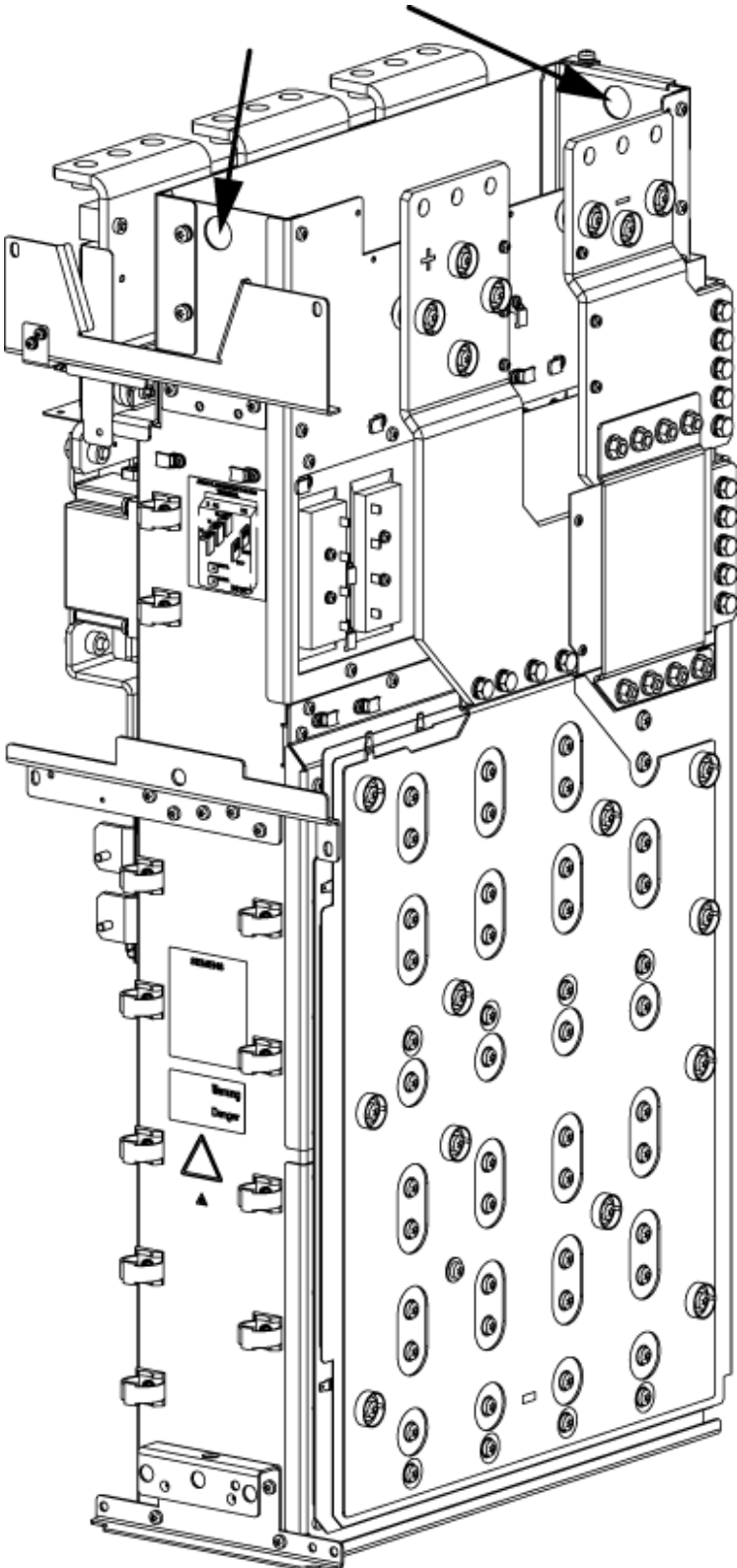

Figure 10-4 Crane lifting lugs on power block frame size GB, GD

Crane lifting lugs for Motor Modules Chassis-2

Motor Modules Chassis-2 are fitted with crane lifting lugs for transport using a lifting harness to facilitate replacement.

The crane lifting lug on the side of the motor connections is used to secure the unit when it is turned and placed on its side, if this is required when the unit is being replaced.

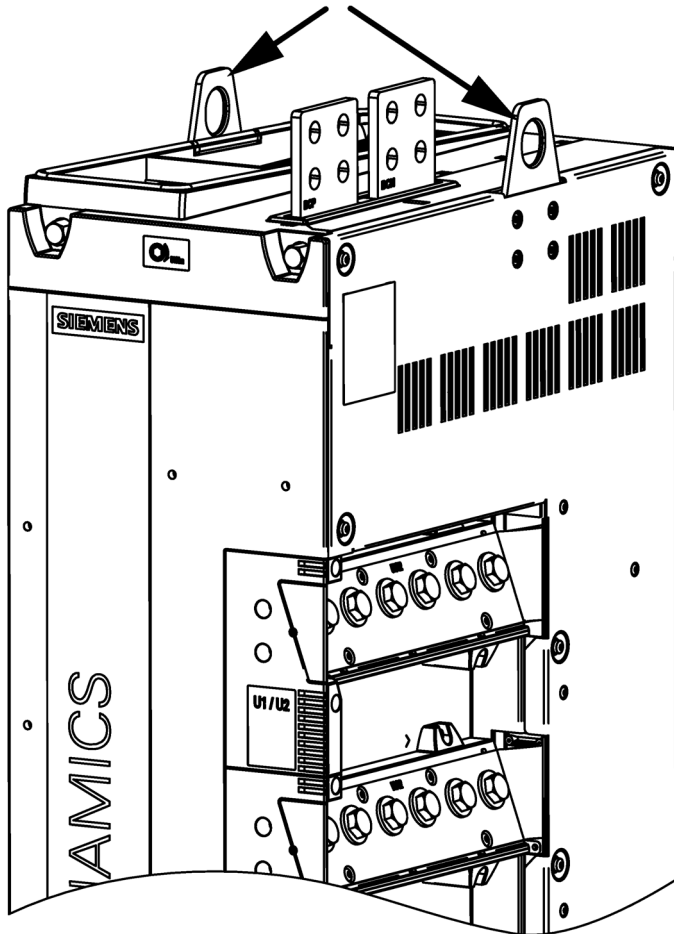



Figure 10-5 Crane lifting lugs for Motor Module Chassis-2, frame size FS4

10.4 Replacing components

10.4.1 Safety information

 WARNING
Improper transport and installation of devices and components
Serious injury or even death and substantial material damage can occur if the devices are not transported or installed properly.
<ul style="list-style-type: none">• Transport, mount, and remove the devices and components only if you are qualified to do so.• Take into account that the devices and components are in some cases heavy and top-heavy; take the necessary precautionary measures. The weights of the individual power blocks are listed in the corresponding section.

10.4.2 Messages after replacement of DRIVE-CLiQ components

After DRIVE-CLiQ components are replaced (Control Interface Module, TM31, SMCxx) when service is required, generally no message is output after power-up, since an identical component is identified and accepted as component when the system boots.

The reason for this is that an identical component is detected and accepted as spare part when running-up. If, unexpectedly, a fault message of the "topology fault" category is displayed, then when replacing a component, one of the following faults/errors should have occurred:

- A Control Interface Module with different firmware data was installed.
- When connecting-up DRIVE-CLiQ cables, connections were interchanged.

Automatic firmware update

A firmware update for the replaced DRIVE-CLiQ component may run automatically after switching on the electronics.

- The following LEDs will flash slowly to indicate that an automatic firmware update is in progress: the "RDY" LED on the Control Unit (orange, 0.5 Hz) and an LED on the relevant DRIVE-CLiQ component (green/red, 0.5 Hz).

Note

Do not shut down the converter

During this operation, the converter should not be shut down, as otherwise the firmware update must be started again.

- Once the automatic firmware update is complete, the "RDY" LED on the Control Unit will flash quickly (orange, 2 Hz) along with an LED on the relevant DRIVE-CLiQ component (green/red, 2 Hz).
- To complete the automatic firmware update process, a POWER ON is required (switch the device off and back on again).

10.4.3 Replacing the power block, Active Line Module, and Motor Module, frame size FX

Replacing the power block

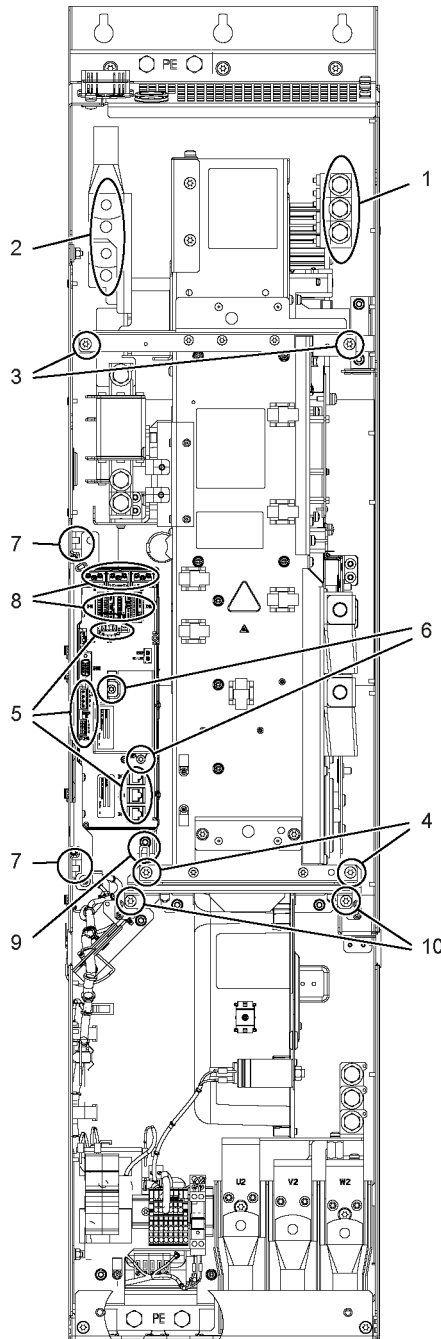

Figure 10-6 Replacing the power block, Active Line Module, and Motor Module, frame size FX

Preparatory steps

- Disconnect the drive line-up from the power supply
- Allow unimpeded access to the power block
- Remove the front cover

Removal

The removal steps are numbered in accordance with the numbers in the diagram.

1. Unscrew the connection to the line or to the motor (three screws).
2. Unscrew the connection to the DC link (four screws).
3. Remove the retaining screws at the top (two screws).
4. Remove the retaining screws at the bottom (two screws).
5. Remove DRIVE-CLiQ cables and connections at -X41/-X42/-X46 (six connectors).
The DRIVE-CLiQ cables should be marked to ensure that they are subsequently correctly inserted.
6. Take out the retaining screws for the IPD card (two screws) and remove the IPD card from plug -X45 on the Control Interface Module.
7. Remove the mounts for the Control Interface Module (two nuts) and carefully pull out the Control Interface Module.

When removing the Control Interface Module, you have to disconnect five additional plugs one after the other (two at the top, three below).
8. Disconnect the plug-in connections for the fiber-optic cables and signal cables (five connectors).
9. Disconnect the plug for the thermocouple.
10. Unscrew the two retaining screws for the fan and attach the equipment for assembling the power block at this position.

You can now remove the power block.

Note

The power block weighs approx. 66 kg!

NOTICE
Damage to the device if signal cables become damaged during removal
Signal cables can become damaged when the power block is removed. This can cause the device to fail.
<ul style="list-style-type: none">• When removing the power block, ensure that you do not damage any signal cables.

Installation steps

To reinstall, perform the above steps in reverse order.

Note

Specifications for the installation

The tightening torques specified in the table "Tightening torques for screw connections" must be observed.

Carefully insert the plug-in connections and ensure that they are secure.

The fiber-optic cable plugs must be remounted at their original slot. Fiber-optic cables and sockets are labeled to ensure that they are assigned correctly (U11, U21, U31).

10.4.4 Replacing the power block, Smart Line Module, Active Line Module, and Motor Module, frame size GX

Replacing the power block

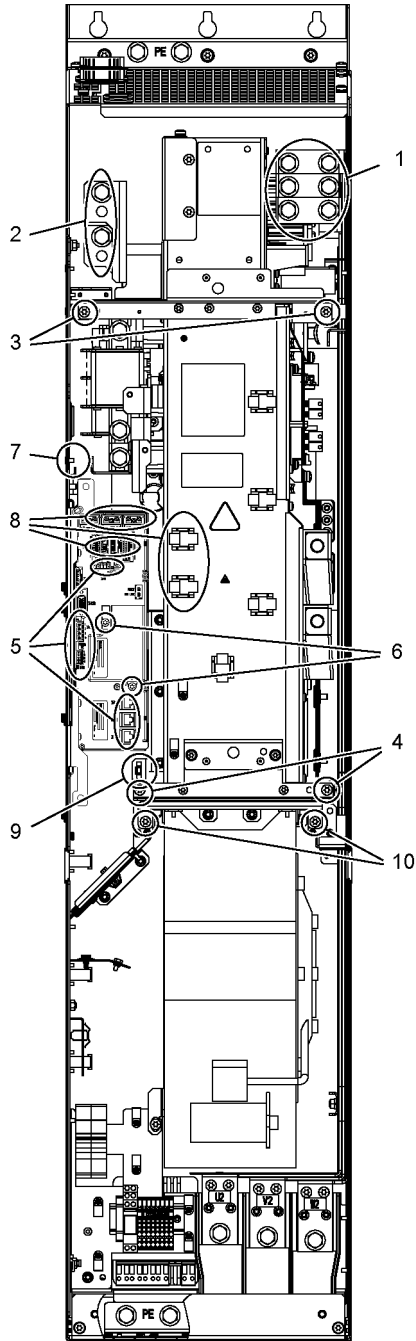

Figure 10-7 Replacing the power block, Smart Line Module, Active Line Module, and Motor Module, frame size GX

Preparatory steps

- Disconnect the drive line-up from the power supply
- Allow unimpeded access to the power block
- Remove the front cover

Removal

The removal steps are numbered in accordance with the numbers in the diagram.

1. Unscrew the connection to the line or to the motor (three screws).
2. Unscrew the connection to the DC link (four screws).
3. Remove the retaining screws at the top (two screws).
4. Remove the retaining screws at the bottom (two screws).
5. Remove DRIVE-CLiQ cables and connections at –X41/–X42/–X46 (six connectors).
The DRIVE-CLiQ cables should be marked to ensure that they are subsequently correctly inserted.
6. Take out the retaining screws for the IPD card (two screws) and remove the IPD card from plug -X45 on the Control Interface Module.
7. Remove the mount for the Control Interface Module (one nut) and carefully pull out the Control Interface Module.

When removing the Control Interface Module, you have to disconnect five additional plugs one after the other (two at the top, three below).
8. Disconnect the plug-in connections for the fiber optic cables and signal cables (five connectors) and release the cable connectors for the signal cables (two connectors).
9. Disconnect the plug for the thermocouple.
10. Unscrew the two retaining screws for the fan and attach the equipment for assembling the power block at this position.

You can now remove the power block.

Note

The power block weighs approx. 89 kg!

NOTICE
<p>Damage to the device if signal cables become damaged during removal</p> <p>Signal cables can become damaged when the power block is removed. This can cause the device to fail.</p> <ul style="list-style-type: none">• When removing the power block, ensure that you do not damage any signal cables.

Installation steps

To reinstall, perform the above steps in reverse order.

Note

Specifications for the installation

The tightening torques specified in the table "Tightening torques for screw connections" must be observed.

Carefully insert the plug-in connections and ensure that they are secure.

The fiber-optic cable plugs must be remounted at their original slot. Fiber-optic cables and sockets are labeled to ensure that they are assigned correctly (U11, U21, U31).

Note

Connection clip for the basic interference suppression module on the Smart Line Module, frame size GX

The connection clip for the basic interference suppression module is mounted on the spare power block together with a yellow warning label.

Please note the information in the chapter "Electrical connection" of the corresponding device.

10.4.5 Replacing the power block, Smart Line Module, Active Line Module, and Motor Module, frame size HX

Replacing the left-hand power block

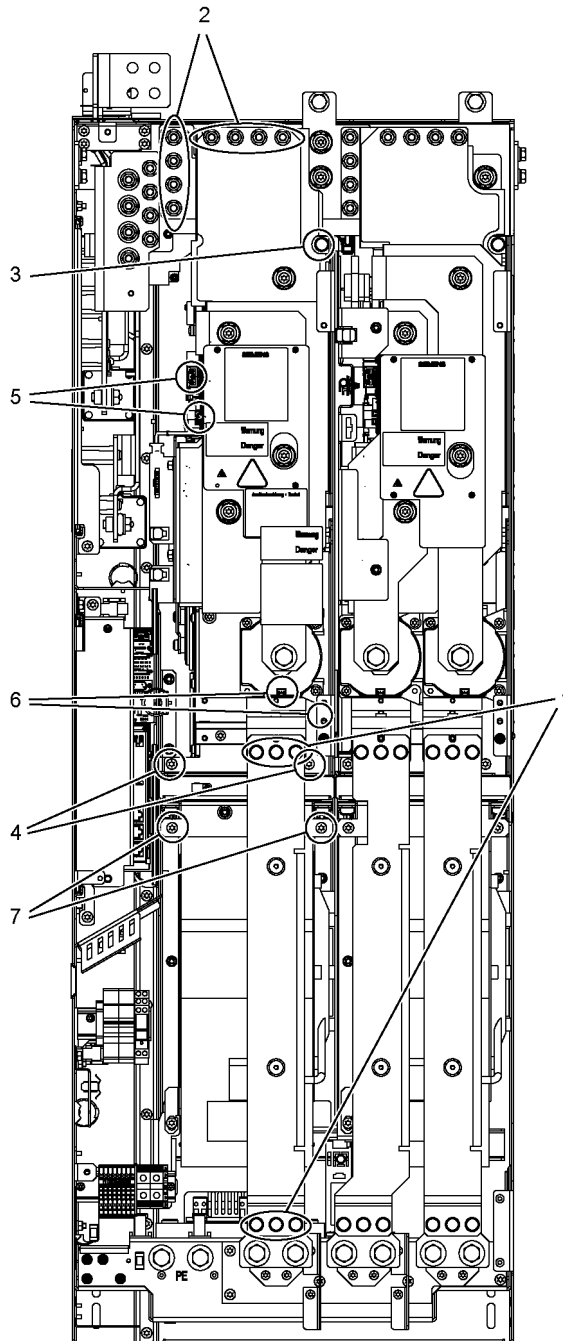

Figure 10-8 Replacing the power block, Smart Line Module, Active Line Module, and Motor Module, frame size HX – left power block

Preparatory steps

- Disconnect the drive line-up from the power supply
- Allow unimpeded access to the power block
- Remove the protective cover

Removal

The removal steps are numbered in accordance with the numbers in the diagram.

1. Remove the busbar (six screws).
2. Unscrew the connection to the DC link (eight nuts).
3. Remove the retaining screw at the top (one screw).
4. Remove the retaining screws at the bottom (two screws).
5. Disconnect the plug-in connections for the fiber-optic cables and signal cables (two connectors).
6. Remove the connection for the current transformer and associated PE connection (one connector).
7. Unscrew the two retaining screws for the fan and attach the equipment for assembling the power block at this position.

You can now remove the power block.

Note

The power block weighs approx. 64 kg!

NOTICE

Damage to the device if signal cables become damaged during removal
--

Signal cables can become damaged when the power block is removed. This can cause the device to fail.
--

- | |
|---|
| <ul style="list-style-type: none">• When removing the power block, ensure that you do not damage any signal cables. |
|---|

Installation steps

To reinstall, perform the above steps in reverse order.

Note

Specifications for the installation

The tightening torques specified in the table "Tightening torques for screw connections" must be observed.

Carefully insert the plug-in connections and ensure that they are secure.

The fiber-optic cable plugs must be remounted at their original slot. Fiber-optic cables and sockets are labeled to ensure that they are assigned correctly (U11, U21, U31).

Replacing the right-hand power block

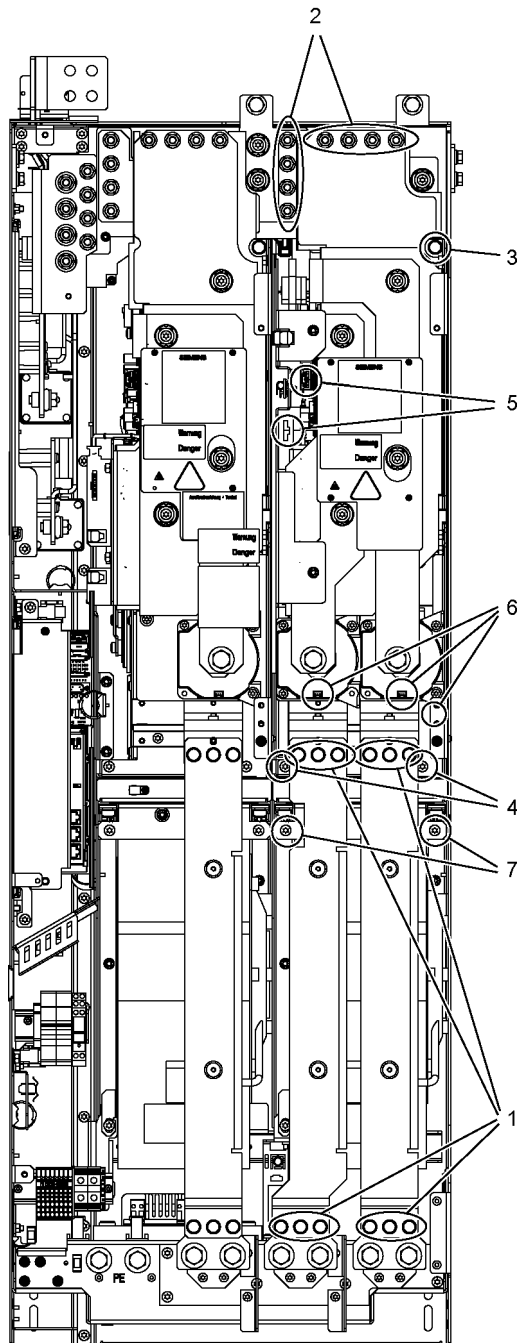

Figure 10-9 Replacing the power block, Smart Line Module, Active Line Module, and Motor Module, frame size HX – right power block

Preparatory steps

- Disconnect the drive line-up from the power supply
- Allow unimpeded access to the power block
- Remove the protective cover

Removal

The removal steps are numbered in accordance with the numbers in the diagram.

1. Remove the busbar (twelve screws).
2. Unscrew the connection to the DC link (eight nuts).
3. Remove the retaining screw at the top (one screw).
4. Remove the retaining screws at the bottom (two screws).
5. Disconnect the plug-in connections for the fiber-optic cables and signal cables (two connectors).

The second plug connection for the fiber optic cables cannot be disconnected until the power block has been pulled out slightly.

6. Remove the connection for the current transformer and associated PE connection (two connectors).
7. Unscrew the two retaining screws for the fan and attach the equipment for assembling the power block at this position.

You can now remove the power block.

Note

The power block weighs approx. 86 kg!

The second plug connection for the fiber optic cables cannot be disconnected until the power block has been pulled out slightly (see Step 5).

NOTICE
Damage to the device if signal cables become damaged during removal
Signal cables can become damaged when the power block is removed. This can cause the device to fail.
<ul style="list-style-type: none">• When removing the power block, ensure that you do not damage any signal cables.

Installation steps

To reinstall, perform the above steps in reverse order.

Note

Specifications for the installation

The tightening torques specified in the table "Tightening torques for screw connections" must be observed.

Carefully insert the plug-in connections and ensure that they are secure.

The fiber-optic cable plugs must be remounted at their original slot. Fiber-optic cables and sockets are labeled to ensure that they are assigned correctly (U11, U21, U31).

10.4.6 Replacing the power block, Smart Line Module, Active Line Module, and Motor Module, frame size JX

Replacing the power block

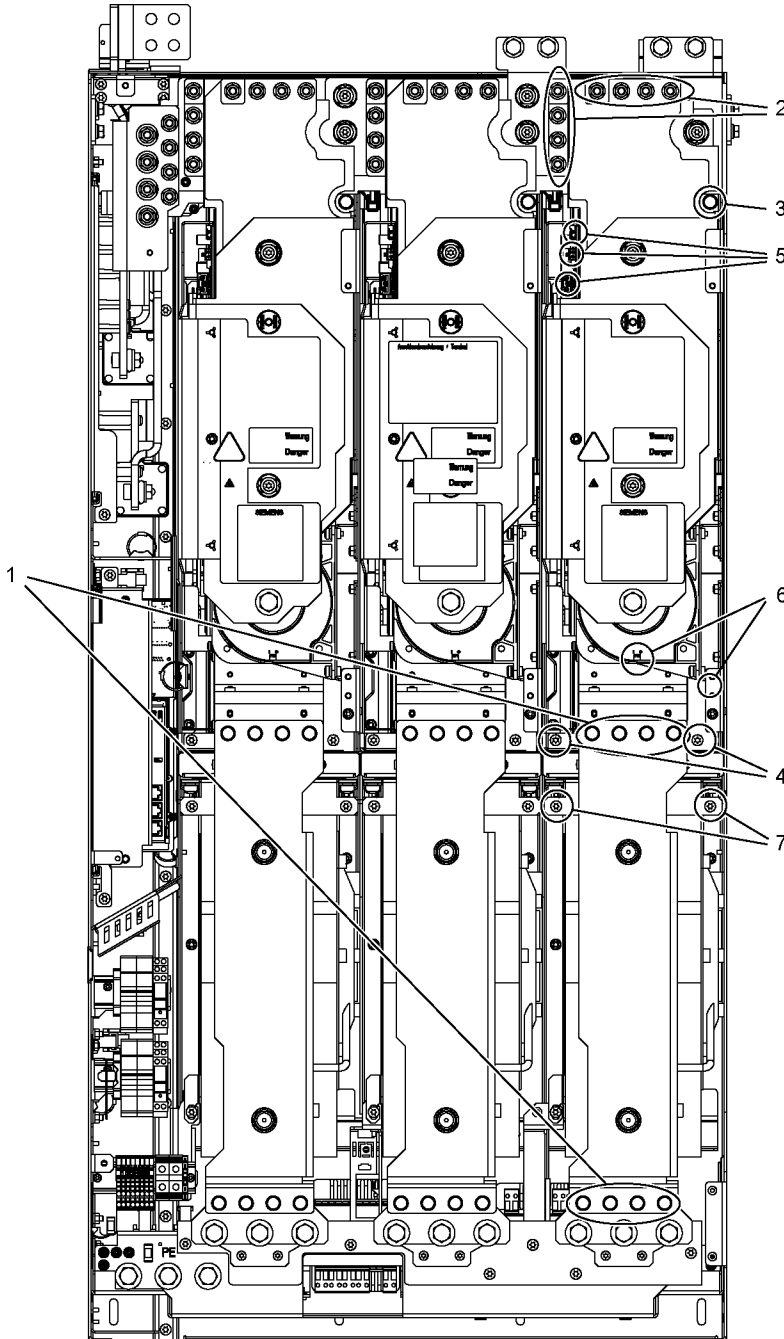

Figure 10-10 Replacing the power block, Smart Line Module, Active Line Module, and Motor Module, frame size JX

Preparatory steps

- Disconnect the drive line-up from the power supply
- Allow unimpeded access to the power block
- Remove the protective cover

Removal

The removal steps are numbered in accordance with the numbers in the diagram.

1. Unscrew the connection to the line or to the motor (eight screws).
2. Unscrew the connection to the DC link (eight nuts).
3. Remove the retaining screw at the top (one screw).
4. Remove the retaining screws at the bottom (two screws).
5. Disconnect the plug-in connections for the fiber-optic cables and signal cables (three connectors).
6. Remove the connection for the current transformer and associated PE connection (one connector).
7. Unscrew the two retaining screws for the fan and attach the equipment for assembling the power block at this position.

You can now remove the power block.

Note

The power block weighs approx. 90 kg!

NOTICE
Damage to the device if signal cables become damaged during removal
Signal cables can become damaged when the power block is removed. This can cause the device to fail.
<ul style="list-style-type: none">• When removing the power block, ensure that you do not damage any signal cables.

Installation steps

To reinstall, perform the above steps in reverse order.

Note

Specifications for the installation

The tightening torques specified in the table "Tightening torques for screw connections" must be observed.

Carefully insert the plug-in connections and ensure that they are secure.

The fiber-optic cable plugs must be remounted at their original slot. Fiber-optic cables and sockets are labeled to ensure that they are assigned correctly (U11, U21, U31).

10.4.7 Replacing the power block, Basic Line Module, frame size FB

Replacing the power block

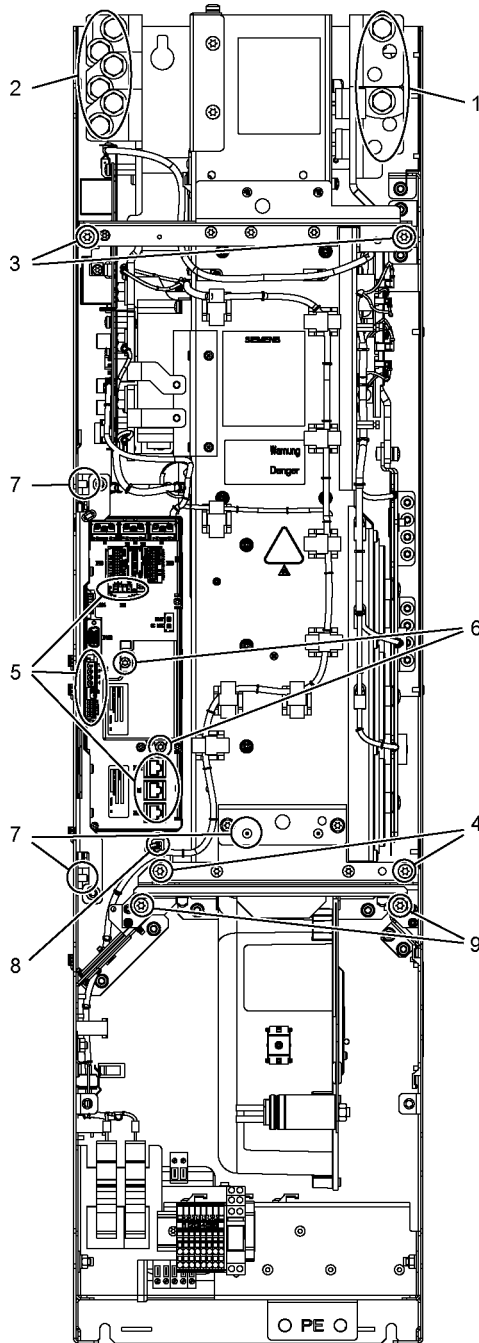

Figure 10-11 Replacing the power block, Basic Line Module, frame size FB

Preparatory steps

- Disconnect the drive line-up from the power supply
- Allow unimpeded access to the power block
- Remove the protective cover

Removal

The removal steps are numbered in accordance with the numbers in the diagram.

1. Unscrew the connection to the DC link (four screws).
2. Unscrew the connection to the line connection (six screws).
3. Remove the retaining screws at the top (two screws).
4. Remove the retaining screws at the bottom (two screws).
5. Remove DRIVE-CLiQ cables and connections at –X41/–X42/–X46 (six connectors).
The DRIVE-CLiQ cables should be marked to ensure that they are subsequently correctly inserted.
6. Take out the retaining screws for the IPD card (two screws) and remove the IPD card from plug -X45 on the Control Interface Module.
7. Remove the mounts for the Control Interface Module (one screw and two nuts) and carefully pull out the Control Interface Module.

When removing the Control Interface Module, you have to disconnect five additional plugs one after the other (two at the top, three below).
8. Disconnect the plug for the thermocouple.
9. Unscrew the two retaining screws for the fan and attach the equipment for assembling the power block at this position.

You can now remove the power block.

Note

The power block weighs approx. 65 kg!

NOTICE

Damage to the device if signal cables become damaged during removal
--

Signal cables can become damaged when the power block is removed. This can cause the device to fail.
--

- | |
|---|
| <ul style="list-style-type: none">• When removing the power block, ensure that you do not damage any signal cables. |
|---|

Installation steps

To reinstall, perform the above steps in reverse order.

Note

Specifications for the installation

The tightening torques specified in the table "Tightening torques for screw connections" must be observed.

Carefully insert the plug-in connections and ensure that they are secure.

Note

Connection clip for the basic interference suppression module

The connection clip for the basic interference suppression module is mounted on the spare power block together with a yellow warning label.

Please note the information in the chapter "Electrical connection" of the corresponding device.

10.4.8 Replacing the power block, Basic Line Module GB, GD

Replacing the power block

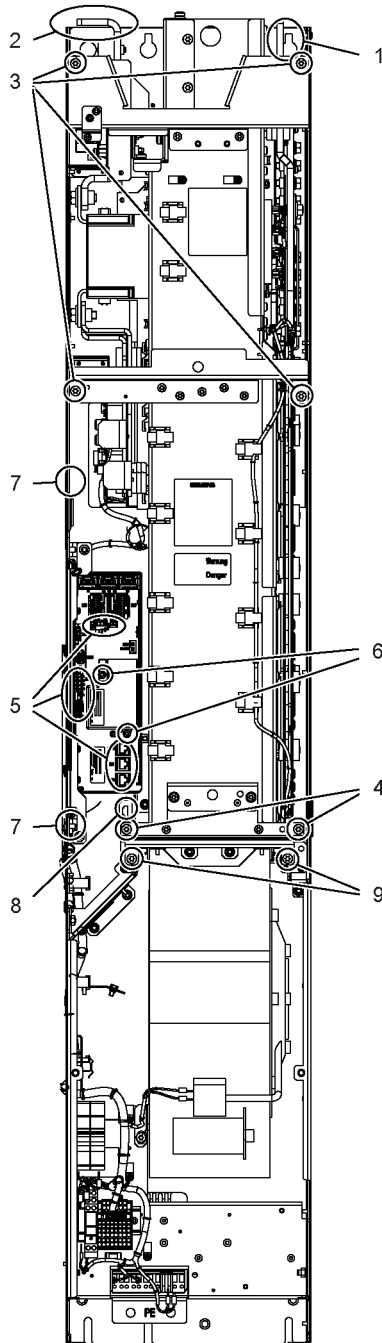

Figure 10-12 Replacing the power block, Basic Line Module, frame sizes GB, GD

Preparatory steps

- Disconnect the drive line-up from the power supply
- Allow unimpeded access to the power block
- Remove the protective cover

Removal

The removal steps are numbered in accordance with the numbers in the diagram.

1. Unscrew the connection to the DC link (six screws).
2. Unscrew the connection to the line connection (nine screws).
3. Remove the retaining screws at the top (four screws).
4. Remove the retaining screws at the bottom (two screws).
5. Remove DRIVE-CLiQ cables and connections at -X41/-X42/-X46 (six connectors).
The DRIVE-CLiQ cables should be marked to ensure that they are subsequently correctly inserted.
6. Take out the retaining screws for the IPD card (two screws) and remove the IPD card from plug -X45 on the Control Interface Module.
7. Remove the mounts for the Control Interface Module (two nuts) and carefully pull out the Control Interface Module.

When removing the Control Interface Module, you have to disconnect five additional plugs one after the other (two at the top, three below).

8. Disconnect the plug for the thermocouple.
9. Unscrew the two retaining screws for the fan and attach the equipment for assembling the power block at this position.

You can now remove the power block.

Note

The power block weighs approx. 135 kg!

NOTICE
<p>Damage to the device if signal cables become damaged during removal</p> <p>Signal cables can become damaged when the power block is removed. This can cause the device to fail.</p> <ul style="list-style-type: none">• When removing the power block, ensure that you do not damage any signal cables.

Installation steps

To reinstall, perform the above steps in reverse order.

Note

Specifications for the installation

The tightening torques specified in the table "Tightening torques for screw connections" must be observed.

Carefully insert the plug-in connections and ensure that they are secure.

Note

Connection clip for the basic interference suppression module

The connection clip for the basic interference suppression module is mounted on the spare power block together with a yellow warning label.

Please note the information in the chapter "Electrical connection" of the corresponding device.

10.4.9 Replacing the Control Interface Module, Active Line Module and Motor Module, frame size FX

Replacing the Control Interface Module

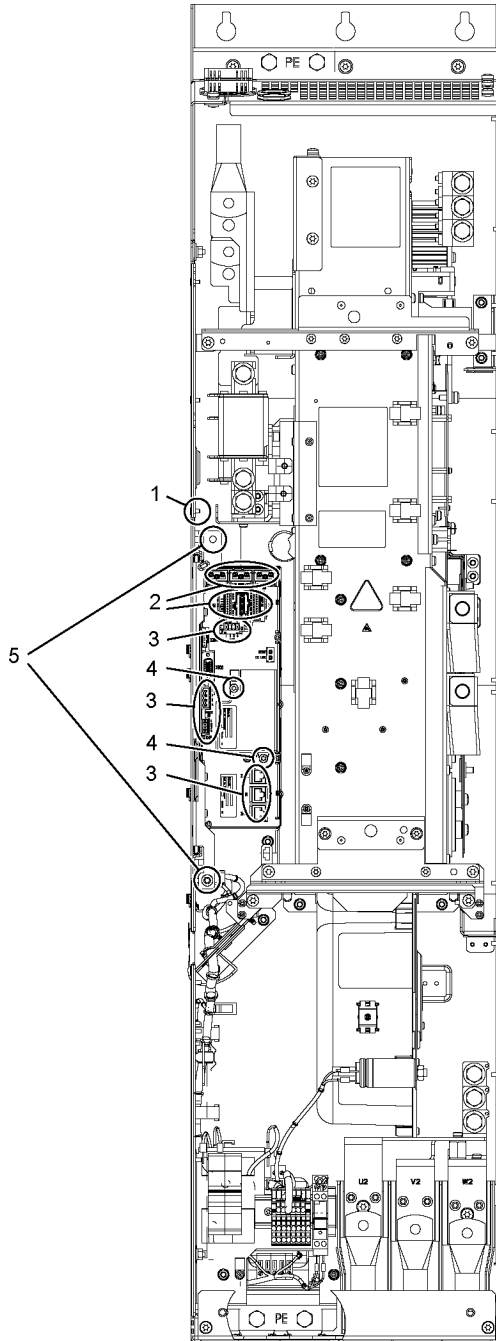

Figure 10-13 Replacing the Control Interface Module, Active Line Module and Motor Module, frame size FX

Preparatory steps

- Disconnect the drive line-up from the power supply
- Allow unimpeded access
- Remove the front cover

Removal

The removal steps are numbered in accordance with the numbers in the diagram.

1. Remove the mount for the CU320 (one nut).
2. Disconnect the plug-in connections for the fiber-optic cables and signal cables (five connectors).
3. Remove DRIVE-CLiQ cables and connections at –X41–X42–X46 (six connectors). The DRIVE-CLiQ cables should be marked to ensure that they are subsequently correctly inserted.
4. Take out the retaining screws for the IPD card (two screws) and remove the IPD card from plug -X45 on the Control Interface Module.
5. Remove the retaining screws for the Control Interface Module (two screws).

When removing the Control Interface Module, you have to disconnect five additional plugs one after the other (two at the top, three below).

NOTICE

Damage to the device if signal cables become damaged during removal

Signal cables can become damaged when the Control Interface Module is removed. This can cause the device to fail.

- When removing the Control Interface Module, ensure that you do not damage any signal cables.

Installation steps

To reinstall, perform the above steps in reverse order.

Tightening torque for the retaining screws of the Control Interface Module (M6 x 16, item ⑤): 6 Nm.

Note

Specifications for the installation

The tightening torques specified in the table "Tightening torques for screw connections" must be observed.

Carefully insert the plug-in connections and ensure that they are secure.

The fiber-optic cable plugs must be remounted at their original slot. Fiber-optic cables and sockets are labeled to ensure that they are assigned correctly (U11, U21, U31).

10.4.10 Replacing the Control Interface Module, Smart Line Module, Active Line Module, and Motor Module, frame size GX

Replacing the Control Interface Module

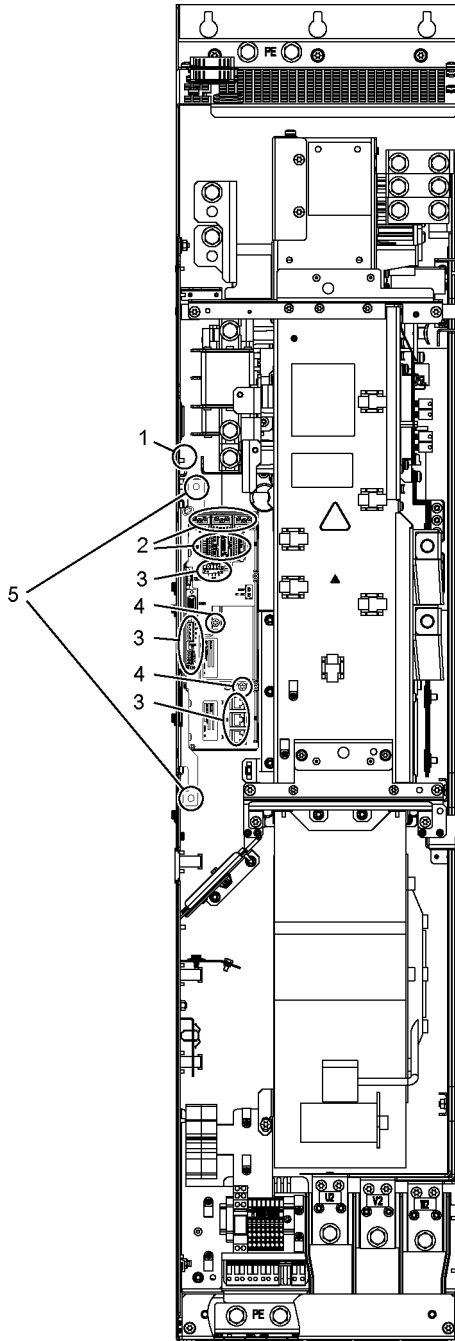

Figure 10-14 Replacing the Control Interface Module, Smart Line Module, Active Line Module, and Motor Module, frame size GX

Preparatory steps

- Disconnect the drive line-up from the power supply
- Allow unimpeded access
- Remove the front cover

Removal

The removal steps are numbered in accordance with the numbers in the diagram.

1. Remove the mount for the CU320 (one nut).
2. Disconnect the plug-in connections for the fiber-optic cables and signal cables (five connectors).
3. Remove DRIVE-CLiQ cables and connections at –X41–X42–X46 (six connectors). The DRIVE-CLiQ cables should be marked to ensure that they are subsequently correctly inserted.
4. Take out the retaining screws for the IPD card (two screws) and remove the IPD card from plug -X45 on the Control Interface Module.
5. Remove the retaining screws for the Control Interface Module (two screws).

When removing the Control Interface Module, you have to disconnect five additional plugs one after the other (two at the top, three below).

NOTICE

Damage to the device if signal cables become damaged during removal

Signal cables can become damaged when the Control Interface Module is removed. This can cause the device to fail.

- When removing the Control Interface Module, ensure that you do not damage any signal cables.

Installation steps

To reinstall, perform the above steps in reverse order.

Tightening torque for the retaining screws of the Control Interface Module (M6 x 16, item ⑤): 6 Nm.

Note

Specifications for the installation

The tightening torques specified in the table "Tightening torques for screw connections" must be observed.

Carefully insert the plug-in connections and ensure that they are secure.

The fiber-optic cable plugs must be remounted at their original slot. Fiber-optic cables and sockets are labeled to ensure that they are assigned correctly (U11, U21, U31).

10.4.11 Replacing the Control Interface Module, Smart Line Module, Active Line Module, and Motor Module, frame size HX

Replacing the Control Interface Module

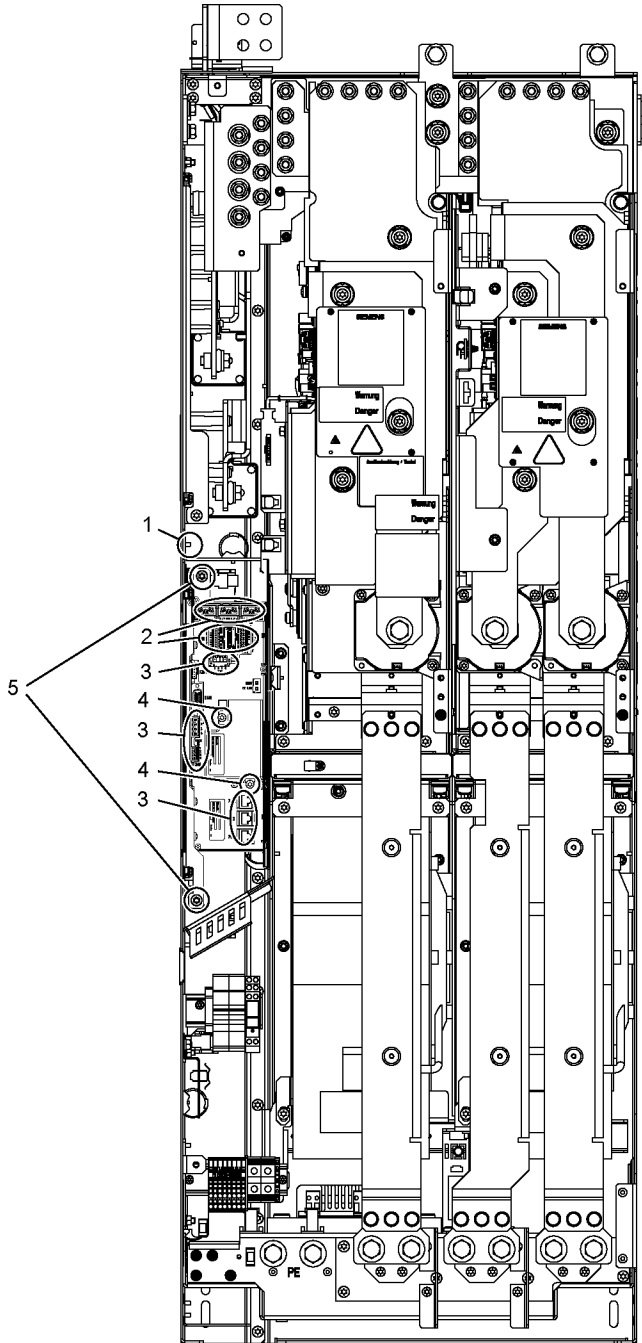

Figure 10-15 Replacing the Control Interface Module, Smart Line Module, Active Line Module, and Motor Module, frame size HX

Preparatory steps

- Disconnect the drive line-up from the power supply
- Allow unimpeded access
- Remove the protective cover

Removal

The removal steps are numbered in accordance with the numbers in the diagram.

1. Remove the mount for the CU320 (one nut).
2. Disconnect the plug-in connections for the fiber-optic cables and signal cables (five connectors).
3. Remove DRIVE-CLiQ cables and connections at –X41–X42–X46 (six connectors). The DRIVE-CLiQ cables should be marked to ensure that they are subsequently correctly inserted.
4. Take out the retaining screws for the IPD card (two screws) and remove the IPD card from plug -X45 on the Control Interface Module.
5. Remove the retaining screws for the Control Interface Module (two screws).

When removing the Control Interface Module, you have to disconnect five additional plugs one after the other (two at the top, three below).

NOTICE

Damage to the device if signal cables become damaged during removal

Signal cables can become damaged when the Control Interface Module is removed. This can cause the device to fail.

- When removing the Control Interface Module, ensure that you do not damage any signal cables.

Installation steps

To reinstall, perform the above steps in reverse order.

Tightening torque for the retaining screws of the Control Interface Module (M6 x 16, item ⑤): 6 Nm.

Note

Specifications for the installation

The tightening torques specified in the table "Tightening torques for screw connections" must be observed.

Carefully insert the plug-in connections and ensure that they are secure.

The fiber-optic cable plugs must be remounted at their original slot. Fiber-optic cables and sockets are labeled to ensure that they are assigned correctly (U11, U21, U31).

10.4.12 Replacing the Control Interface Module, Smart Line Module, Active Line Module, and Motor Module, frame size JX

Replacing the Control Interface Module

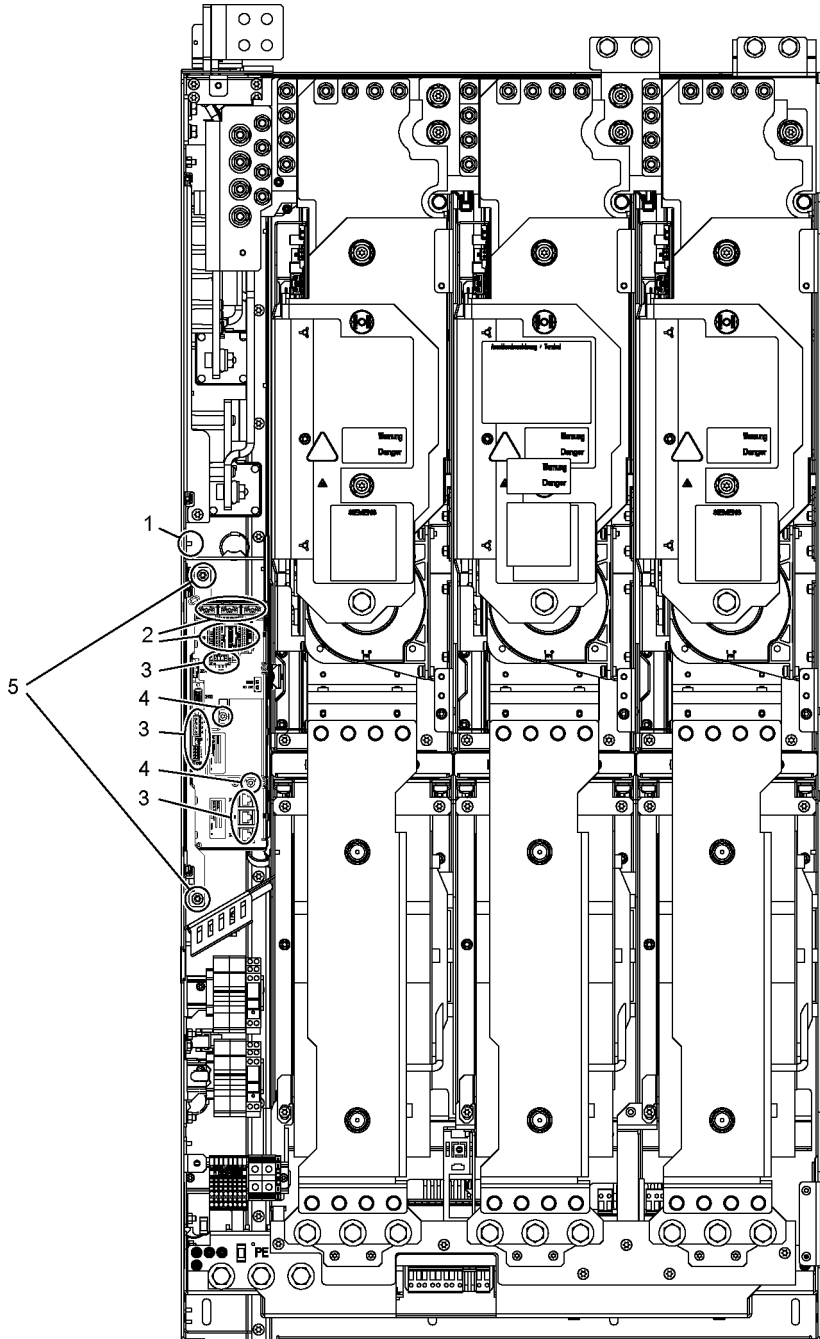

Figure 10-16 Replacing the Control Interface Module, Smart Line Module, Active Line Module, and Motor Module, frame size JX

Preparatory steps

- Disconnect the drive line-up from the power supply
- Allow unimpeded access
- Remove the protective cover

Removal

The removal steps are numbered in accordance with the numbers in the diagram.

1. Remove the mount for the CU320 (one nut).
2. Disconnect the plug-in connections for the fiber-optic cables and signal cables (five connectors).
3. Remove DRIVE-CLiQ cables and connections at –X41–X42–X46 (six connectors). The DRIVE-CLiQ cables should be marked to ensure that they are subsequently correctly inserted.
4. Take out the retaining screws for the IPD card (two screws) and remove the IPD card from plug -X45 on the Control Interface Module.
5. Remove the retaining screws for the Control Interface Module (two screws).

When removing the Control Interface Module, you have to disconnect five additional plugs one after the other (two at the top, three below).

NOTICE

Damage to the device if signal cables become damaged during removal

Signal cables can become damaged when the Control Interface Module is removed. This can cause the device to fail.

- When removing the Control Interface Module, ensure that you do not damage any signal cables.

Installation steps

To reinstall, perform the above steps in reverse order.

Tightening torque for the retaining screws of the Control Interface Module (M6 x 16, item ⑤): 6 Nm.

Note

Specifications for the installation

The tightening torques specified in the table "Tightening torques for screw connections" must be observed.

Carefully insert the plug-in connections and ensure that they are secure.

The fiber-optic cable plugs must be remounted at their original slot. Fiber-optic cables and sockets are labeled to ensure that they are assigned correctly (U11, U21, U31).

10.4.13 Replacing the Control Interface Module, Motor Module Chassis-2, frame size FS4

Replacing the Control Interface Module

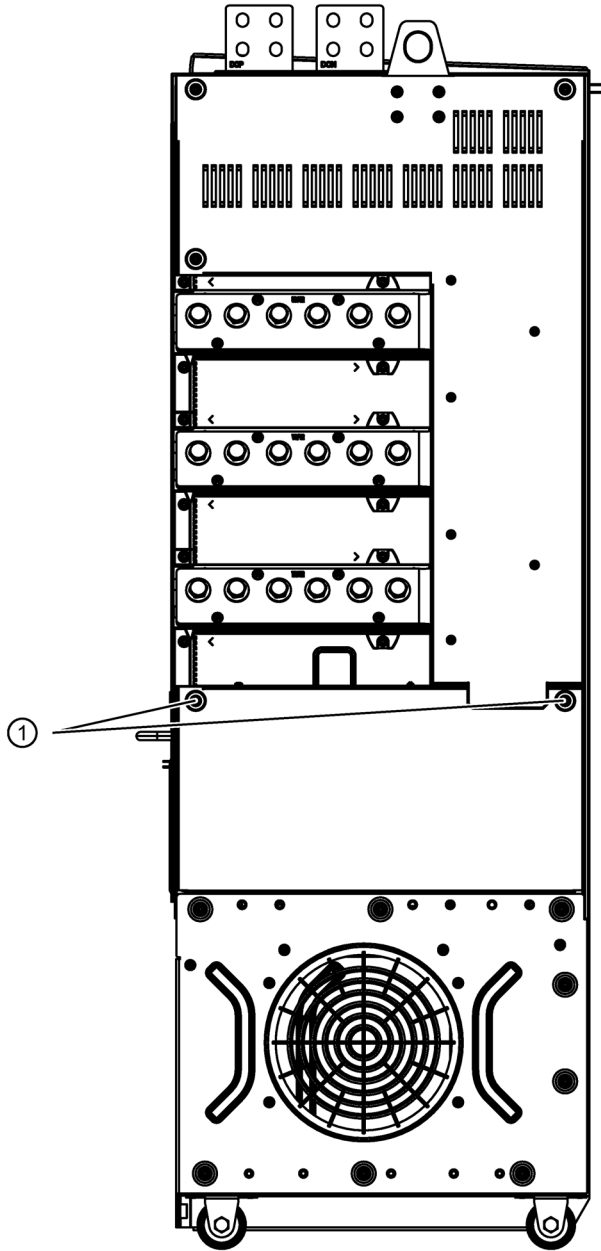

Figure 10-17 Replacing the Control Interface Module, Motor Module Chassis-2, frame size FS4, Part 1

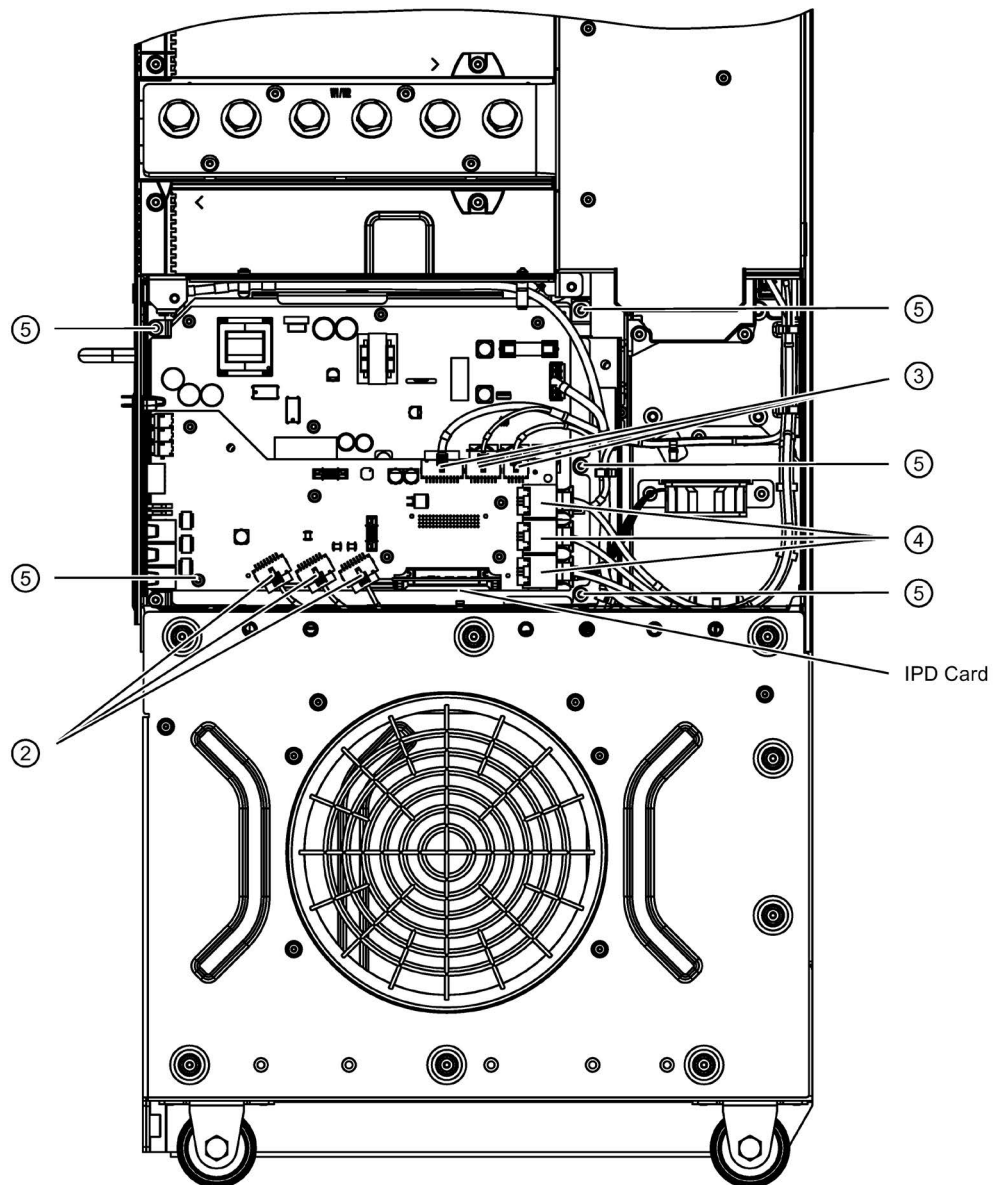

Figure 10-18 Replacing the Control Interface Module, Motor Module Chassis-2, frame size FS4, Part 2

Preparatory steps

- Disconnect the drive line-up from the power supply
- Allow unimpeded access
- Remove the protective cover
- Withdraw all plug connectors to the signal connections (-X9, -X41 ... -X49, -X400 ... -X402).
- When being removed from the electrical cabinet, the device must be carefully secured so that it can neither topple over nor roll away.

Removal

The removal step numbering corresponds to the numbers in the diagrams.

1. Open the service flap for the Control Interface Module (2 screws).
2. Withdraw the plug connectors of the current transformer (3 plug connectors).
3. Withdraw the plug connectors for the main fan (2 plug connectors) and the DC link sensing (1 plug connector).
4. Withdraw the plug connectors of the fiber-optic cables (3 plug connectors).
5. Remove the retaining screws for the Control Interface Module (5 screws).

You can now remove the Control Interface Module.

NOTICE

Damage to the device if signal cables become damaged during removal

Signal cables can be damaged when withdrawing the Control Interface Module, which can result in a device failure.

- When withdrawing the Control Interface Module, ensure that you do not damage any signal cables.

Transferring the IPD card

When replacing the Control Interface Module with a replacement part, after removing the defective module, the IPD card must be transferred into the replacement part.

The IPD card contains the internal device data; it is not included with a replacement Control Interface Module.

Remove the IPD Card:

Open the locking mechanism and withdraw the IPD card from the Control Interface Module.

Insert the IPD card:

Insert the IPD card into the slot until the locking mechanism engages.

Installation steps

To reinstall, perform the above steps in reverse order.

Tightening torque for the fastening screws of the Control Interface Module (M6 x 16, item ⑤): 6 Nm.

Note

Specifications for the installation

The tightening torques specified in the table "Tightening torques for screw connections" must be observed.

Carefully insert the plug-in connections and ensure that they are secure.

The fiber-optic cable plugs must be remounted at their original slot. Fiber-optic cables and sockets are labeled to ensure that they are assigned correctly (U11, U21, U31).

10.4.14 Replacing the Control Interface Module, Basic Line Module, frame size FB

Replacing the Control Interface Module

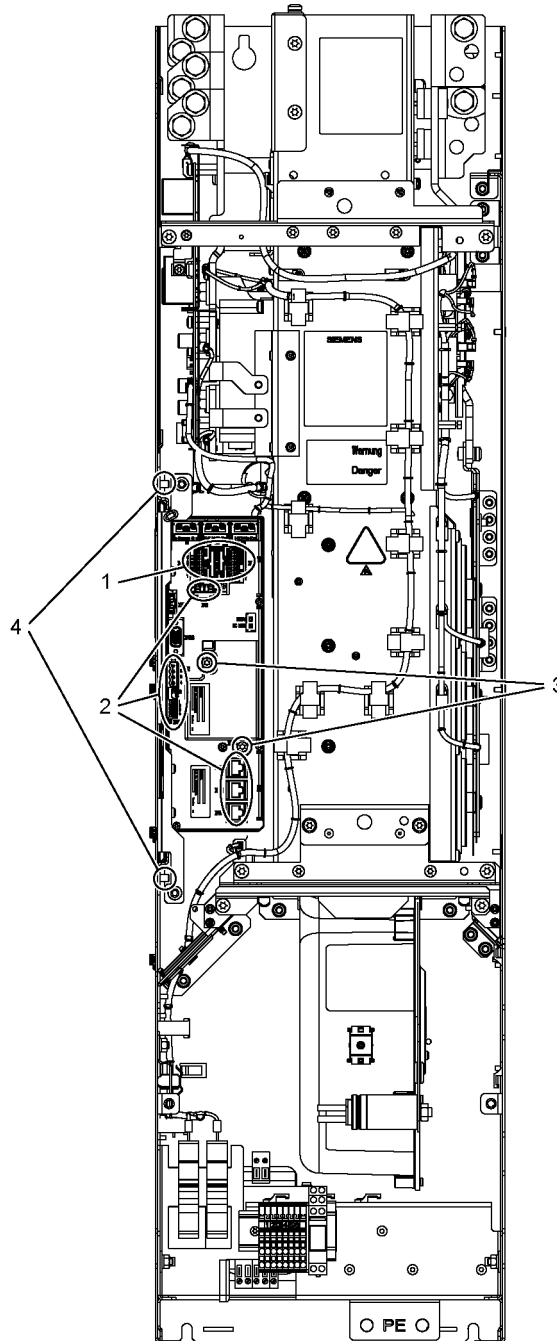

Figure 10-19 Replacing the Control Interface Module, Basic Line Module, frame size FB

Preparatory steps

- Disconnect the drive line-up from the power supply
- Allow unimpeded access
- Remove the front cover

Removal

The removal steps are numbered in accordance with the numbers in the diagram.

1. Disconnect the plugs for the signal cables (two connectors).
2. Remove DRIVE-CLiQ cables and connections at -X41/-X42/-X46 (six connectors).
The DRIVE-CLiQ cables should be marked to ensure that they are subsequently correctly inserted.
3. Take out the retaining screws for the IPD card (two screws) and remove the IPD card from plug -X45 on the Control Interface Module.
4. Remove the retaining screws for the Control Interface Module (two screws).

When removing the Control Interface Module, you have to disconnect five additional plugs one after the other (two at the top, three below).

NOTICE
Damage to the device if signal cables become damaged during removal
Signal cables can become damaged when the Control Interface Module is removed. This can cause the device to fail.
<ul style="list-style-type: none">• When removing the Control Interface Module, ensure that you do not damage any signal cables.

Installation steps

To reinstall, perform the above steps in reverse order.

Tightening torque for the retaining screws of the Control Interface Module (M6 x 16, item ④): 6 Nm.

Note

Specifications for the installation

The tightening torques specified in the table "Tightening torques for screw connections" must be observed.

Carefully insert the plug-in connections and ensure that they are secure.

10.4.15 Replacing the Control Interface Module, Basic Line Module, frame size GB, GD

Replacing the Control Interface Module

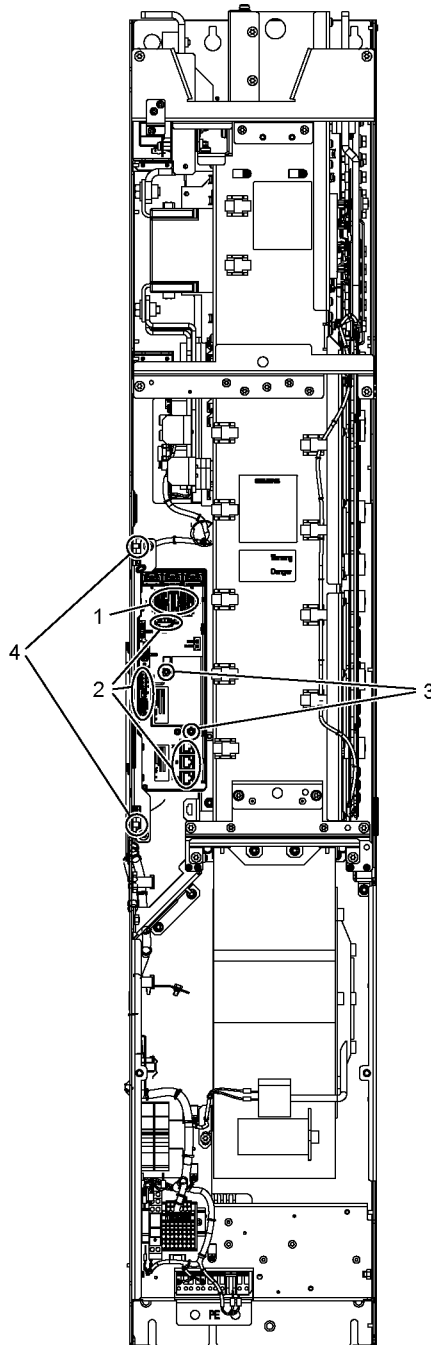

Figure 10-20 Replacing the Control Interface Module, Basic Line Module, frame sizes GB, GD

Preparatory steps

- Disconnect the drive line-up from the power supply
- Allow unimpeded access
- Remove the front cover

Removal

The removal steps are numbered in accordance with the numbers in the diagram.

1. Disconnect the plugs for the signal cables (two connectors).
2. Remove DRIVE-CLiQ cables and connections at -X41/-X42/-X46 (six connectors).
The DRIVE-CLiQ cables should be marked to ensure that they are subsequently correctly inserted.
3. Take out the retaining screws for the IPD card (two screws) and remove the IPD card from plug -X45 on the Control Interface Module.
4. Remove the retaining screws for the Control Interface Module (two screws).

When removing the Control Interface Module, you have to disconnect five additional plugs one after the other (two at the top, three below).

NOTICE
Damage to the device if signal cables become damaged during removal
Signal cables can become damaged when the Control Interface Module is removed. This can cause the device to fail.
<ul style="list-style-type: none">• When removing the Control Interface Module, ensure that you do not damage any signal cables.

Installation steps

To reinstall, perform the above steps in reverse order.

Tightening torque for the retaining screws of the Control Interface Module (M6 x 16, item ④): 6 Nm.

Note

Specifications for the installation

The tightening torques specified in the table "Tightening torques for screw connections" must be observed.

Carefully insert the plug-in connections and ensure that they are secure.

10.4.16 Replacing the fan, Smart Line Module, Active Line Module, and Motor Module, frame sizes FX, GX

Replacing the fan

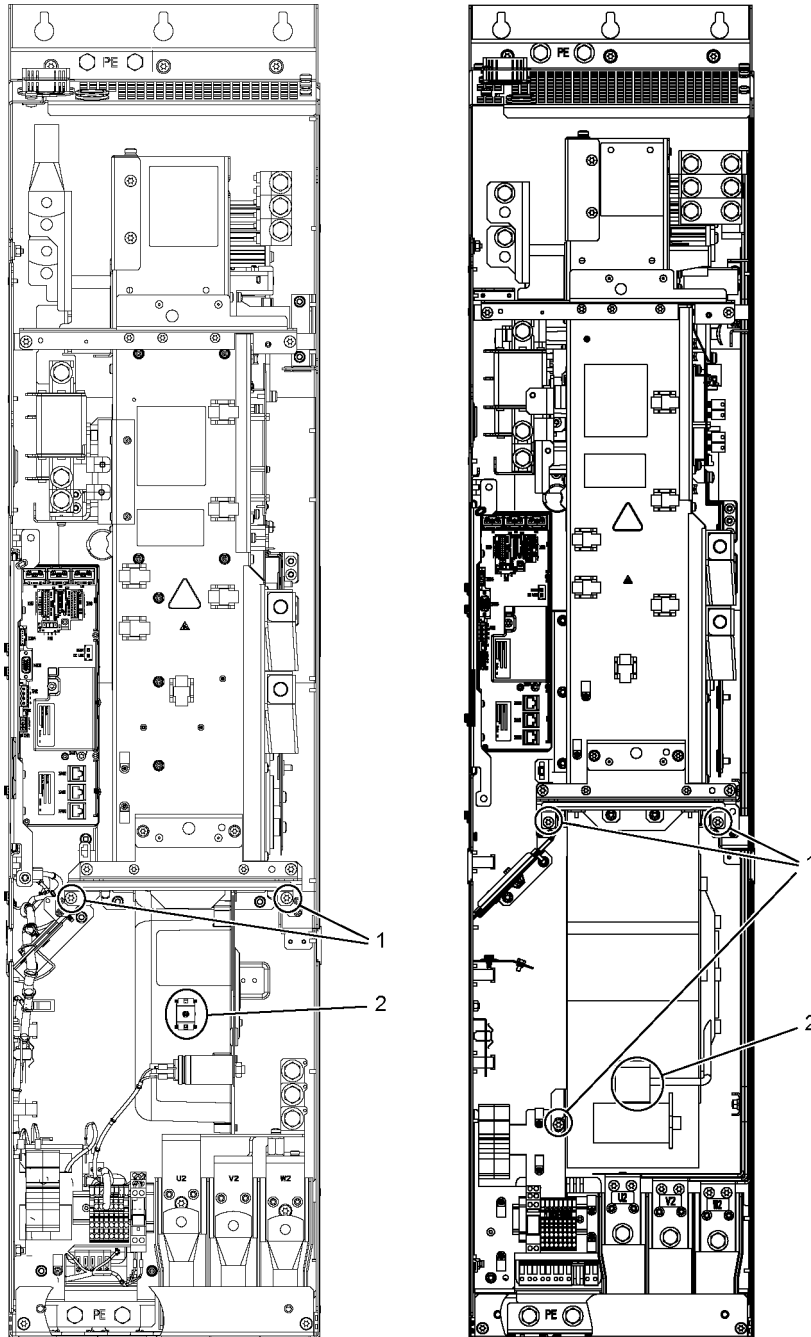

Figure 10-21 Replacing the fan, Smart Line Module, Active Line Module, and Motor Module, frame sizes FX, GX

Description

The average service life of the device fans is 50,000 hours. In practice, however, the service life depends on other variables (e.g. ambient temperature, degree of cabinet protection, etc.) and, therefore, may deviate from this value.

The fans must be replaced in good time to ensure that the device is available.

Preparatory steps

- Disconnect the drive line-up from the power supply
- Allow unimpeded access
- Remove the front cover

Removal

The removal steps are numbered in accordance with the numbers in the diagram.

1. Remove the retaining screws for the fan
(2 for FX; 3 for GX).
2. Disconnect the supply cables (1 x "L", 1 x "N").

You can now carefully remove the fan.

NOTICE
Damage to the device if signal cables become damaged during removal
Signal cables can become damaged when the fan is removed. This can cause the device to fail.
<ul style="list-style-type: none">• When removing the fan, ensure that you do not damage any signal cables.

Installation steps

To reinstall, perform the above steps in reverse order.

Note

Pay attention to the tightening torques

The tightening torques specified in the table "Tightening torques for screw connections" must be observed.

10.4.17 Replacing the fan, Smart Line Module, Active Line Module, and Motor Module, frame size HX

Replacing the fan (left-hand power block)

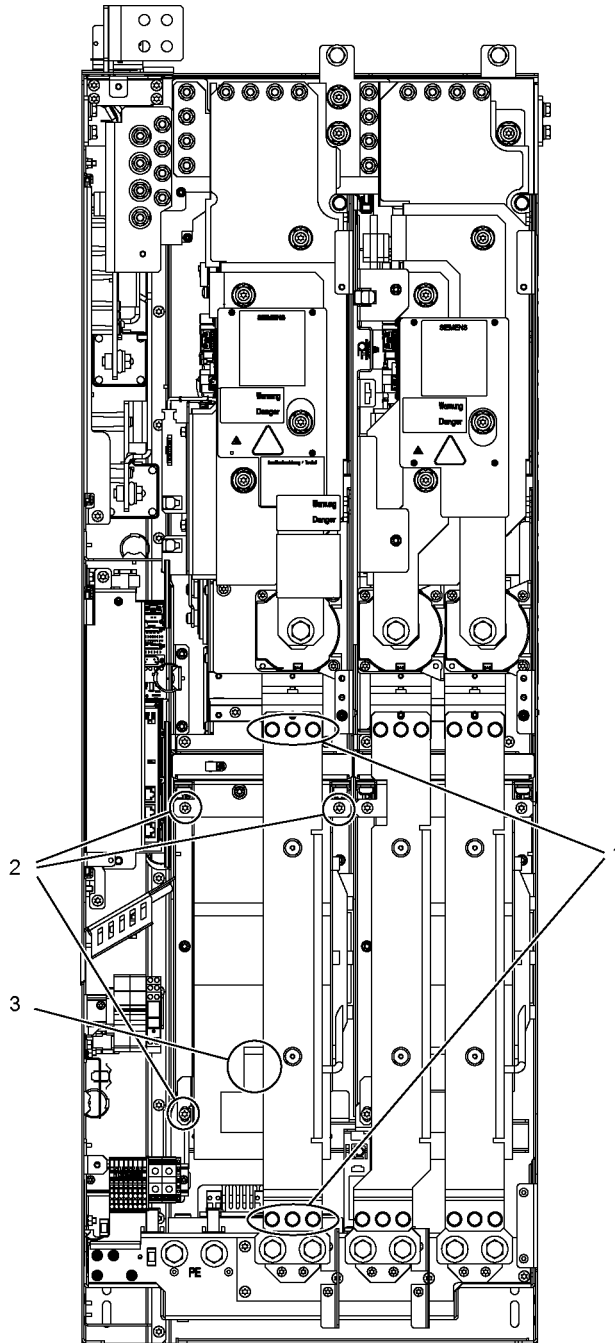

Figure 10-22 Replacing the fan, Smart Line Module, Active Line Module, and Motor Module, frame size HX – left power block

Description

The average service life of the device fans is 50,000 hours. In practice, however, the service life depends on other variables (e.g. ambient temperature, degree of cabinet protection, etc.) and, therefore, may deviate from this value.

The fans must be replaced in good time to ensure that the device is available.

Preparatory steps

- Disconnect the drive line-up from the power supply
- Allow unimpeded access
- Remove the protective cover

Removal

The removal steps are numbered in accordance with the numbers in the diagram.

1. Remove the busbar (six screws).
2. Remove the retaining screws for the fan (three screws).
3. Disconnect the supply cables (1 x "L", 1 x "N").

You can now carefully remove the fan.

NOTICE
Damage to the device if signal cables become damaged during removal
Signal cables can become damaged when the fan is removed. This can cause the device to fail.
<ul style="list-style-type: none">• When removing the fan, ensure that you do not damage any signal cables.

Installation steps

To reinstall, perform the above steps in reverse order.

Note

Pay attention to the tightening torques

The tightening torques specified in the table "Tightening torques for screw connections" must be observed.

Replacing the fan (right-hand power block)

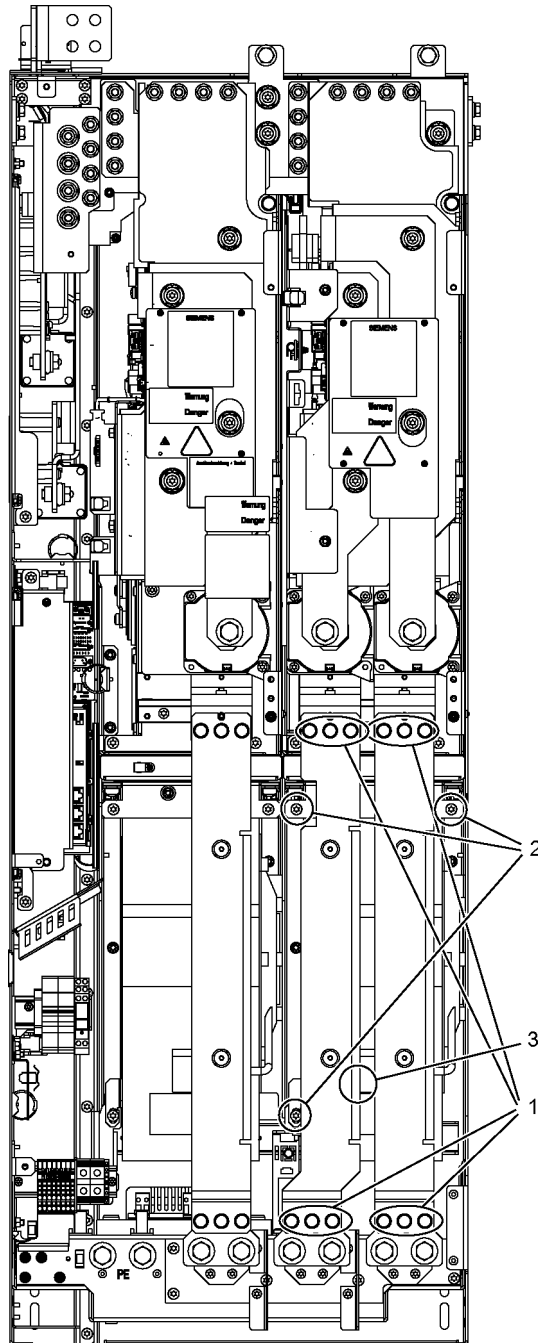

Figure 10-23 Replacing the fan, Smart Line Module, Active Line Module, and Motor Module, frame size HX – right power block

Description

The average service life of the device fans is 50,000 hours. In practice, however, the service life depends on other variables (e.g. ambient temperature, degree of cabinet protection, etc.) and, therefore, may deviate from this value.

The fans must be replaced in good time to ensure that the device is available.

Preparatory steps

- Disconnect the drive line-up from the power supply
- Allow unimpeded access
- Remove the protective cover

Removal

The removal steps are numbered in accordance with the numbers in the diagram.

1. Remove the busbars (twelve screws).
2. Remove the retaining screws for the fan (three screws).
3. Disconnect the supply cables (1 x "L", 1 x "N").

You can now carefully remove the fan.

NOTICE
Damage to the device if signal cables become damaged during removal
Signal cables can become damaged when the fan is removed. This can cause the device to fail.
<ul style="list-style-type: none">• When removing the fan, ensure that you do not damage any signal cables.

Installation steps

To reinstall, perform the above steps in reverse order.

Note

Pay attention to the tightening torques

The tightening torques specified in the table "Tightening torques for screw connections" must be observed.

10.4.18 Replacing the fan, Smart Line Module, Active Line Module, and Motor Module, frame size JX

Replacing the fan

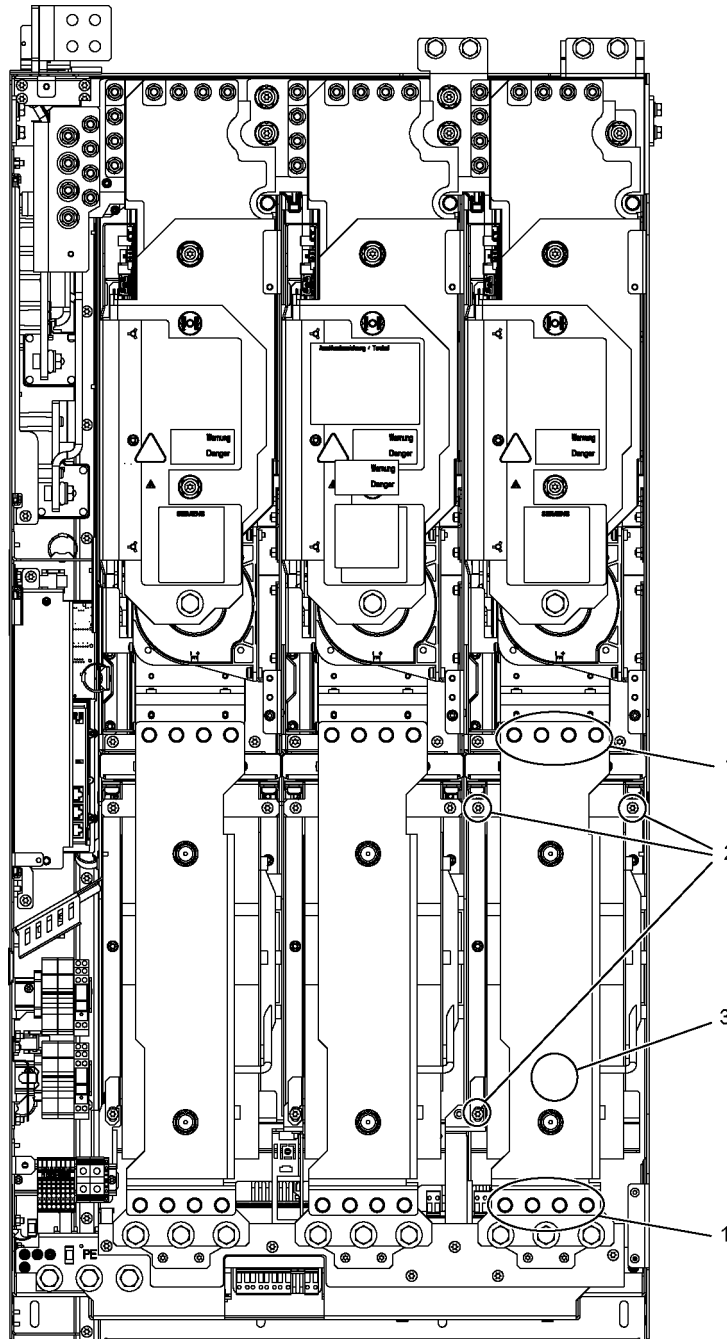

Figure 10-24 Replacing the fan, Smart Line Module, Active Line Module, and Motor Module, frame size JX

Description

The average service life of the device fans is 50,000 hours. In practice, however, the service life depends on other variables (e.g. ambient temperature, degree of cabinet protection, etc.) and, therefore, may deviate from this value.

The fans must be replaced in good time to ensure that the device is available.

Preparatory steps

- Disconnect the drive line-up from the power supply
- Allow unimpeded access
- Remove the protective cover

Removal

The removal steps are numbered in accordance with the numbers in the diagram.

1. Remove the busbar (eight screws).
2. Remove the retaining screws for the fan (three screws).
3. Disconnect the supply cables (1 x "L", 1 x "N").

You can now carefully remove the fan.

NOTICE
Damage to the device if signal cables become damaged during removal
Signal cables can become damaged when the fan is removed. This can cause the device to fail.
<ul style="list-style-type: none">• When removing the fan, ensure that you do not damage any signal cables.

Installation steps

To reinstall, perform the above steps in reverse order.

Note

Pay attention to the tightening torques

The tightening torques specified in the table "Tightening torques for screw connections" must be observed.

10.4.19 Replacing the fan, Motor Module Chassis-2, frame size FS4

Replacing the fan

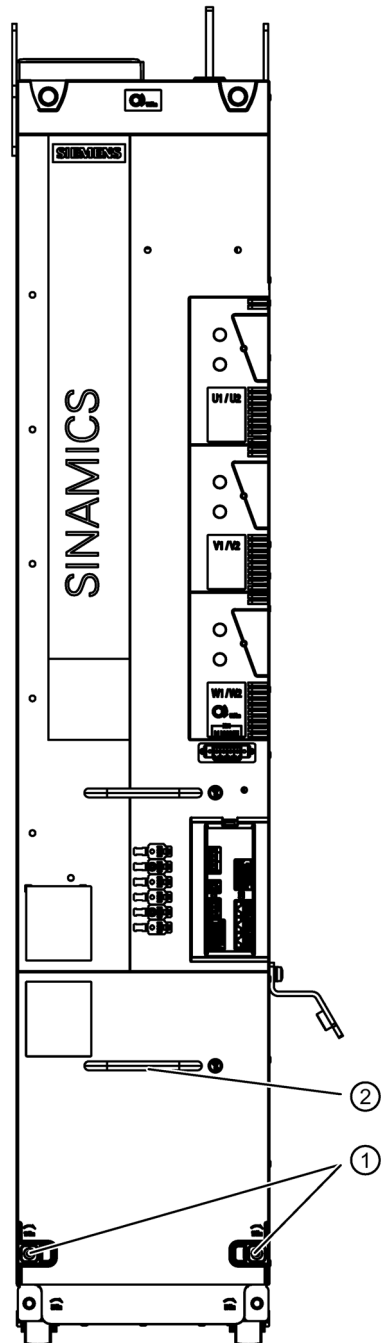

Figure 10-25 Replacing the fan, Motor Module Chassis-2, frame size FS4

Description

The fan is monitored in operation, and does not permanently run, only when required.

The expected remaining operating time of the fan can be read-out from parameter p0277 "Heat sink fan wear counter".

500 hours before reaching the maximum operating duration, Alarm A30042 "Power unit: Fan has reached the maximum operating hours" indicated with alarm value "0" in r2124.

When reaching 99% of the maximum operating duration, Alarm A30042 is output with alarm value "1" in r2124.

When reaching the maximum operating duration, Alarm A30042 is output with alarm value "2" in r2124.

If the fan no longer operates correctly, then this is signaled using Alarm A30048 "Power unit: Fan defective" with alarm value "0" is indicated in r2124.

If the fan does not correctly operate within 10 seconds after powering up after the pulses have been enabled, then fault F30058 "Power Unit: Heat sink fan defective" is displayed and shut down with OFF2.

The fans must be replaced in good time to ensure that the device is available.

Preparatory steps

- Disconnect the drive line-up from the power supply
- Allow unimpeded access
- Remove the protective cover

Removal

The removal steps are numbered in accordance with the numbers in the diagram.

1. Remove the retaining screws for the Control Interface Module (2 screws).
2. Completely remove the fan assembly from the device. The power supply automatically disengages when withdrawing.

NOTICE
Secure the fan module so that cannot topple over
When withdrawing the fan module, the module housing or the plug connector can be damaged if the module is not secured to prevent it toppling over.
<ul style="list-style-type: none">• Carefully withdraw the fan module and secure it so that it cannot topple over.

Installation steps

To reinstall, perform the above steps in reverse order. The power supply automatically engages when inserting.

The tightening torque of the fixing screws for the fan assembly is 10 Nm.

10.4.20 Replacing the electronic fan, Motor Module Chassis-2, frame size FS4

Replacing the electronic fan

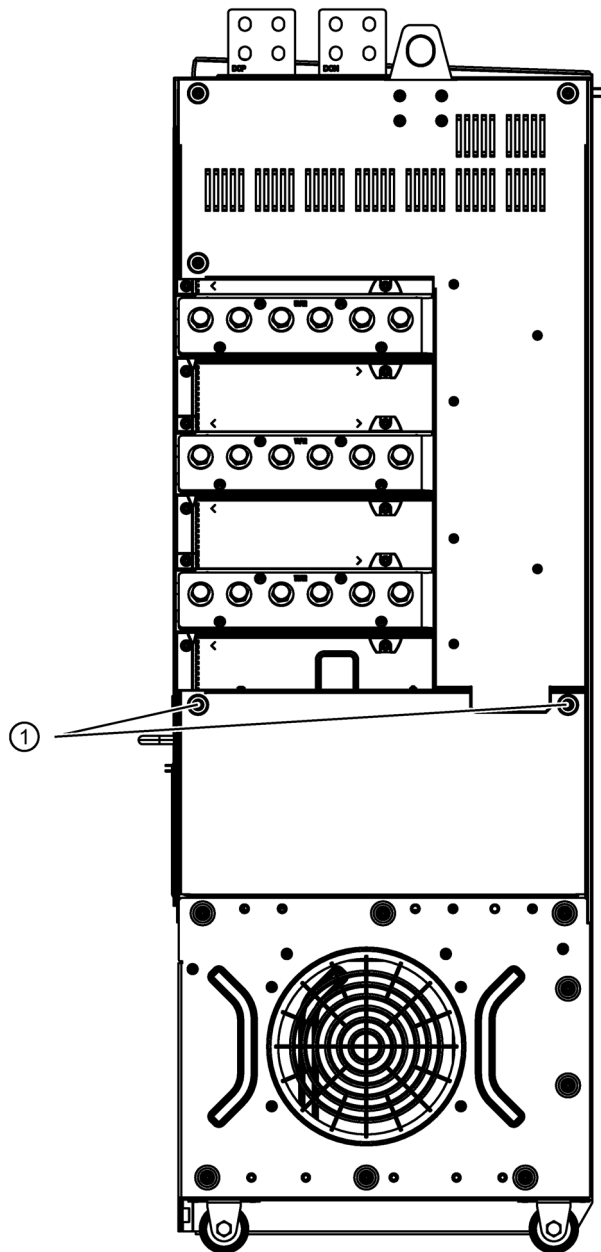

Figure 10-26 Replacing the electronic fan, Motor Module Chassis-2, frame size FS4, Part 1

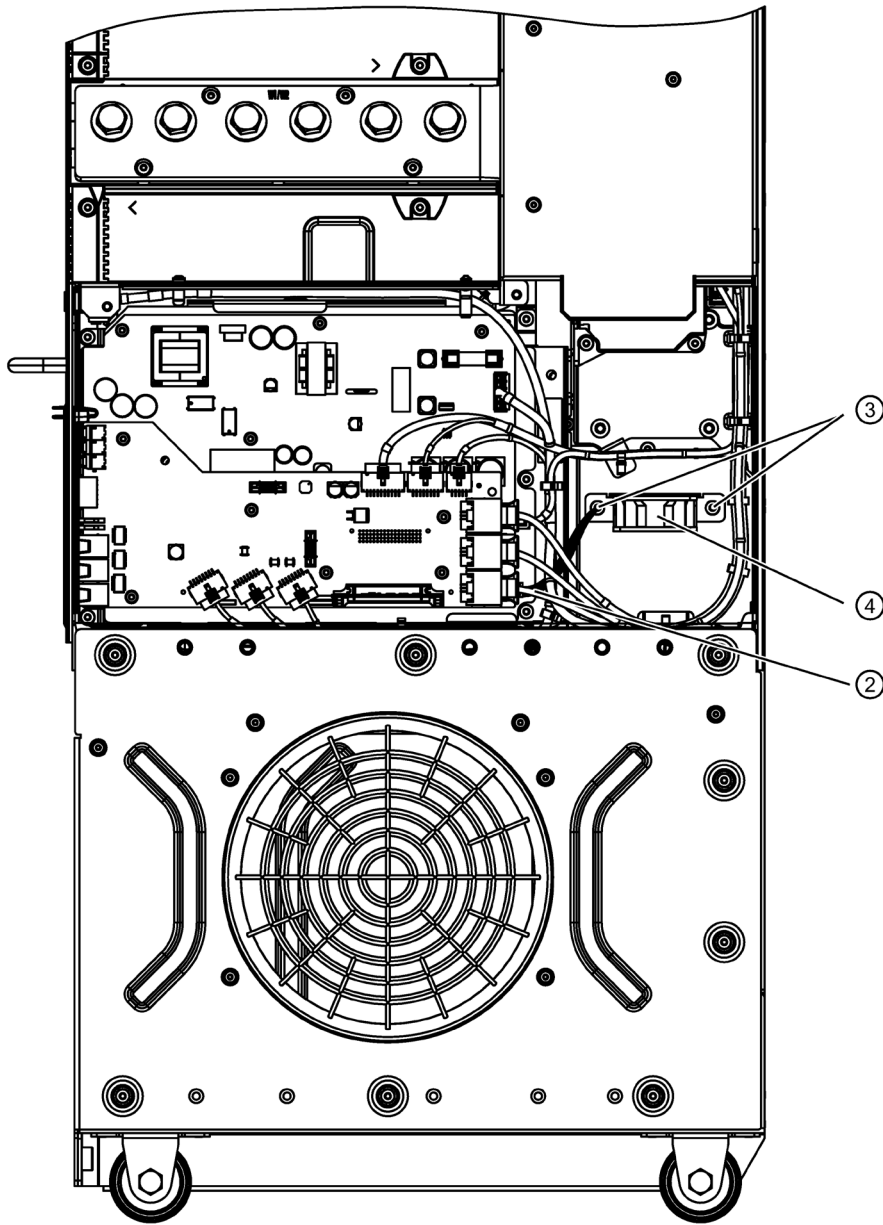

Figure 10-27 Replacing the electronic fan, Motor Module Chassis-2, frame size FS4, Part 2

Description

The service life of the electronic fan is designed for the typical service life of the device itself – it doesn't operate continuously, but only when required. The electronic fan is monitored in operation.

If the fan no longer operates correctly, then this is signaled using Alarm A30048 "Power unit: Fan defective" with alarm value "1" in r2124.

If, with Alarm A30048 active, the measured air intake temperature indicated in r0037[3] violates an appropriate threshold, then fault F30059 "Power unit: Interior fan defective" is displayed, and the system is shut down with OFF2.

Preparatory steps

- Disconnect the drive line-up from the power supply
- Allow unimpeded access
- Remove the protective cover
- After it has been removed from the electrical cabinet, the device must be secured so that it can either topple over nor roll away.

Removal

The removal step numbering corresponds to the numbers in the diagrams.

1. Open the service flap for the Control Interface Module (2 screws).
2. Withdraw the plug connector for the electronic fan the power supply.
3. Release the fastening screws for the electronic fan (2 screws).
4. Remove the electronic fan.

Installation steps

To reinstall, perform the above steps in reverse order.

Tightening torque for the fastening screws of the electronic fan (M6 x 16, item ③): 6 Nm.

Note

Pay attention to the tightening torques

The tightening torques specified in the table "Tightening torques for screw connections" must be observed.

10.4.21 Replacing the fan, Active Interface Module, frame size FI

Replacing the fan

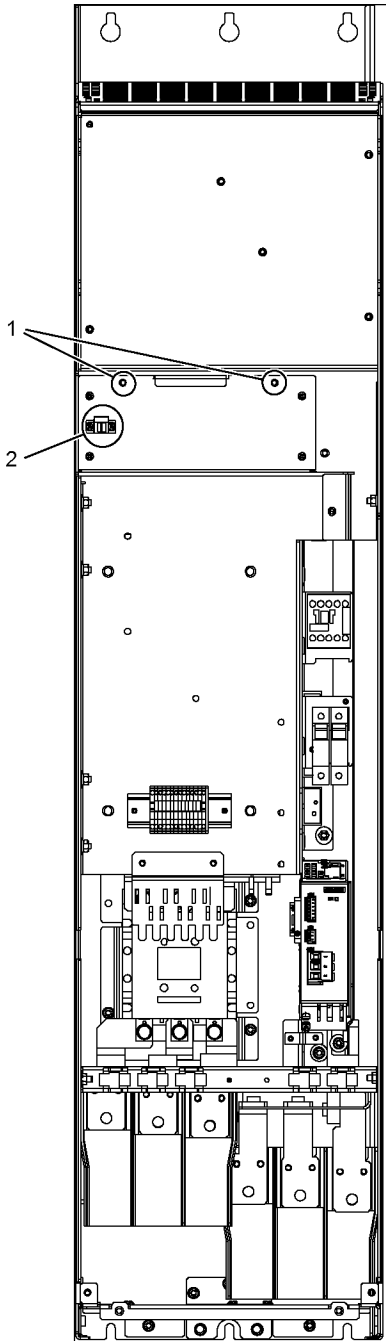

Figure 10-28 Replacing the fan, Active Interface Module, frame size FI

Description

The average service life of the device fans is 50,000 hours. In practice, however, the service life depends on other variables (e.g. ambient temperature, degree of cabinet protection, etc.) and, therefore, may deviate from this value.

The fans must be replaced in good time to ensure that the device is available.

Preparatory steps

- Disconnect the drive line-up from the power supply
- Allow unimpeded access
- Remove the protective cover

Removal

The removal steps are numbered in accordance with the numbers in the diagram.

1. Remove the retaining screws for the fan unit (two screws).
2. Unplug connector –X630.

You can now carefully remove the fan.

NOTICE
Damage to the device if signal cables become damaged during removal
Signal cables can become damaged when the fan is removed. This can cause the device to fail.
<ul style="list-style-type: none">• When removing the fan, ensure that you do not damage any signal cables.

Installation steps

To reinstall, perform the above steps in reverse order.

Note

Pay attention to the tightening torques

The tightening torques specified in the table "Tightening torques for screw connections" must be observed.

10.4.22 Replacing the fan, Active Interface Module, frame size GI

Replacing the fan

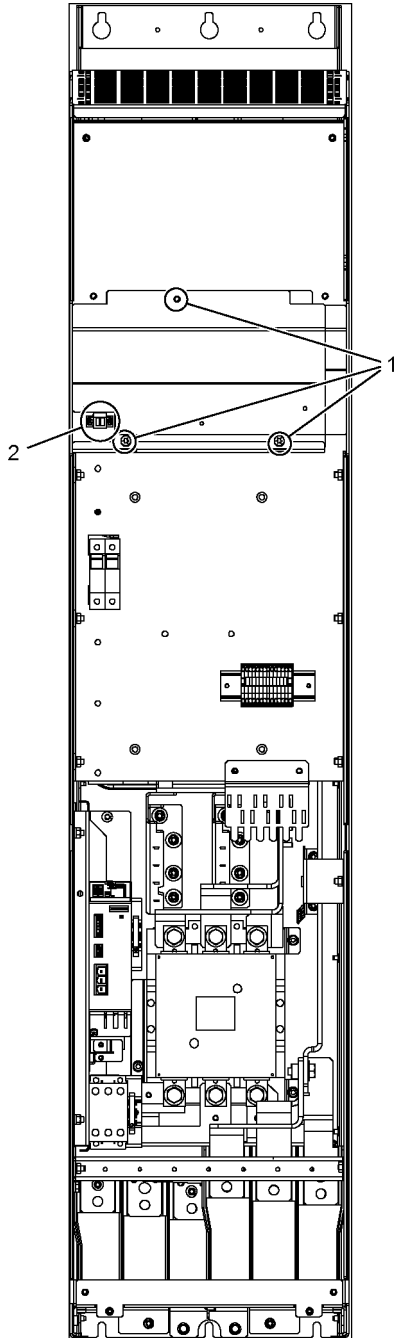

Figure 10-29 Replacing the fan, Active Interface Module, frame size GI

Description

The average service life of the device fans is 50,000 hours. In practice, however, the service life depends on other variables (e.g. ambient temperature, degree of cabinet protection, etc.) and, therefore, may deviate from this value.

The fans must be replaced in good time to ensure that the device is available.

Preparatory steps

- Disconnect the drive line-up from the power supply.
- Allow unimpeded access
- Remove the protective cover

Removal

The removal steps are numbered in accordance with the numbers in the diagram.

1. Remove the retaining screws for the fan unit (3 screws).
2. Unplug connector –X630.

You can now carefully remove the fan.

NOTICE
Damage to the device if signal cables become damaged during removal
Signal cables can become damaged when the fan is removed. This can cause the device to fail.
<ul style="list-style-type: none">• When removing the fan, ensure that you do not damage any signal cables.

Installation steps

To reinstall, perform the above steps in reverse order.

Note

Pay attention to the tightening torques

The tightening torques specified in the table "Tightening torques for screw connections" must be observed.

10.4.23 Replacing the fan, Active Interface Module, frame size HI

Replacing the fan

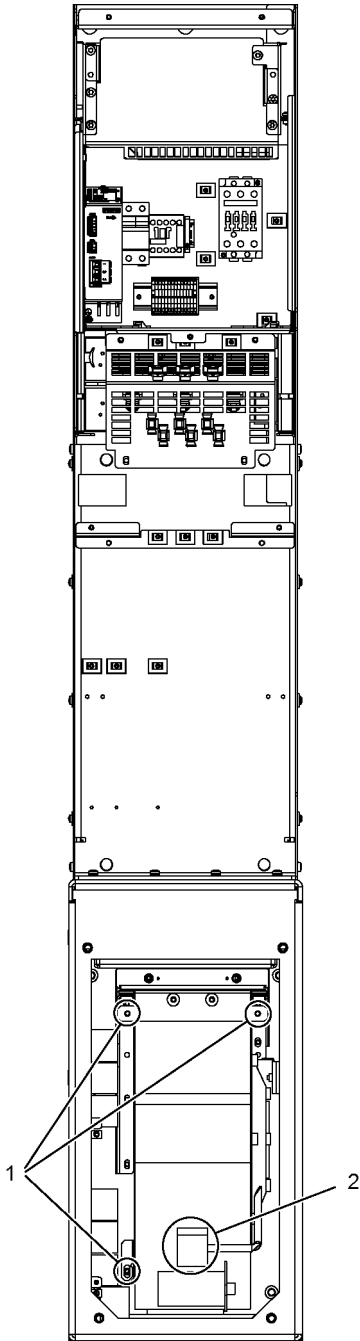

Figure 10-30 Replacing the fan, Active Interface Module, frame size HI

Description

The average service life of the device fans is 50,000 hours. In practice, however, the service life depends on other variables (e.g. ambient temperature, degree of cabinet protection, etc.) and, therefore, may deviate from this value.

The fans must be replaced in good time to ensure that the device is available.

Preparatory steps

- Disconnect the drive line-up from the power supply
- Allow unimpeded access
- Remove the protective cover

Removal

The removal steps are numbered in accordance with the numbers in the diagram.

1. Remove the retaining screws for the fan unit (3 screws).
2. Disconnect the supply cables (1 x "L", 1 x "N").

You can now carefully remove the fan.

NOTICE
Damage to the device if signal cables become damaged during removal
Signal cables can become damaged when the fan is removed. This can cause the device to fail.
<ul style="list-style-type: none">• When removing the fan, ensure that you do not damage any signal cables.

Installation steps

To reinstall, perform the above steps in reverse order.

Note

Pay attention to the tightening torques

The tightening torques specified in the table "Tightening torques for screw connections" must be observed.

10.4.24 Replacing the fan, Active Interface Module, frame size JI

Replacing the fan

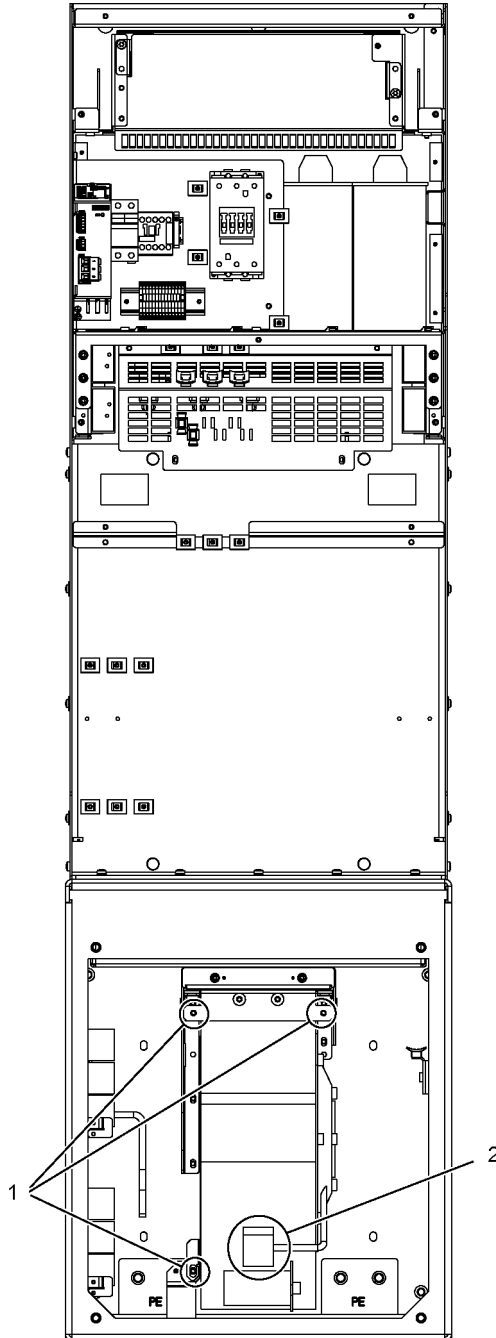

Figure 10-31 Replacing the fan, Active Interface Module, frame size JI

Description

The average service life of the device fans is 50,000 hours. In practice, however, the service life depends on other variables (e.g. ambient temperature, degree of cabinet protection, etc.) and, therefore, may deviate from this value.

The fans must be replaced in good time to ensure that the device is available.

Preparatory steps

- Disconnect the drive line-up from the power supply
- Allow unimpeded access
- Remove the protective cover

Removal

The removal steps are numbered in accordance with the numbers in the diagram.

1. Remove the retaining screws for the fan unit (3 screws).
2. Disconnect the supply cables (1 x "L", 1 x "N").

You can now carefully remove the fan.

NOTICE
Damage to the device if signal cables become damaged during removal
Signal cables can become damaged when the fan is removed. This can cause the device to fail.
<ul style="list-style-type: none">• When removing the fan, ensure that you do not damage any signal cables.

Installation steps

To reinstall, perform the above steps in reverse order.

Note

Pay attention to the tightening torques

The tightening torques specified in the table "Tightening torques for screw connections" must be observed.

10.4.25 Replacing the fan, Basic Line Module, frame sizes FB, GB, GD

Replacing the fan

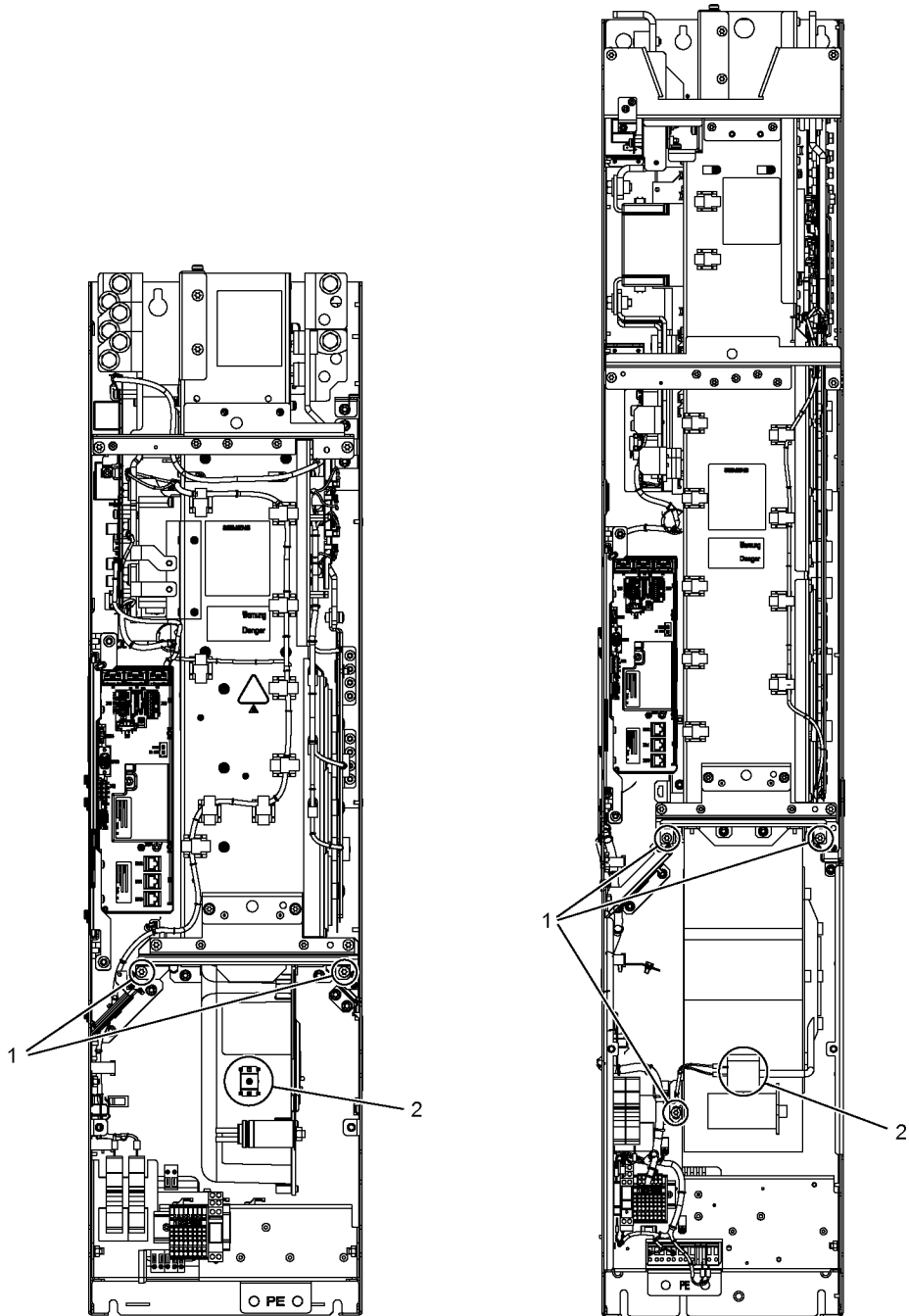

Figure 10-32 Replacing the fan, Basic Line Module, frame sizes FB, GB and GD

Description

The average service life of the device fans is 50,000 hours. In practice, however, the service life depends on other variables (e.g. ambient temperature, degree of cabinet protection, etc.) and, therefore, may deviate from this value.

The fans must be replaced in good time to ensure that the device is available.

Preparatory steps

- Disconnect the drive line-up from the power supply
- Allow unimpeded access
- Remove the protective cover

Removal

The removal steps are numbered in accordance with the numbers in the diagram.

1. Remove the retaining screws for the fan
(two screws for frame size FB, three screws for frame size GB)
2. Disconnect the supply cables (1 x "L", 1 x "N").

You can now carefully remove the fan.

NOTICE

Damage to the device if signal cables become damaged during removal

Signal cables can become damaged when the fan is removed. This can cause the device to fail.

- When removing the fan, ensure that you do not damage any signal cables.

Installation steps

To reinstall, perform the above steps in reverse order.

Note

Pay attention to the tightening torques

The tightening torques specified in the table "Tightening torques for screw connections" must be observed.

10.4.26 Replacing the DC fuses, Smart Line Module, Active Line Module, and Motor Module, frame size HX

Replacing the DC fuses

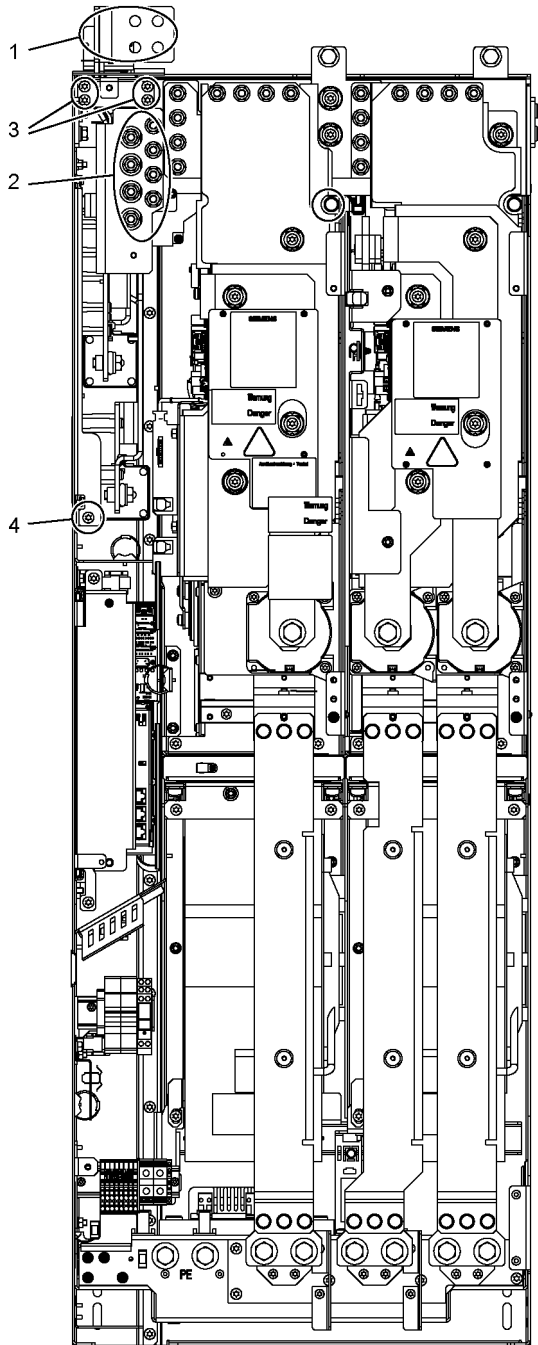

Figure 10-33 Replacing the DC fuses, Smart Line Module, Active Line Module, and Motor Module, frame size HX

Description

The DC fuses are installed in a fuse insert. To replace the fuses, the fuse insert be removed.

NOTICE

Device failure after a DC fuse trips

The neighboring DC fuses may also become damaged if a DC fuse trips. Failure to replace all fuses at the same time can cause the device to fail.

- After a DC fuse trips, always replace all DC fuses at the same time. Always use fuses of the same type.

Preparatory steps

- Disconnect the drive line-up from the power supply
- Allow unimpeded access
- Remove the protective cover

Removal

The removal steps are numbered in accordance with the numbers in the diagram.

1. Release the DC connections at DCP and DCN (four screws each)
2. Remove nuts (eight screws)
3. Remove the retaining screws for the connection plate of the housing (four screws) and remove the connection plate
4. Remove the retaining screw for the fuse insert (one screw)

You can now remove the fuse insert.

NOTICE

Damage to the device if signal cables or plastic parts become damaged during removal

Signal cables or plastic parts can become damaged when the fuse insert is removed. This can cause the device to fail.

- When removing the fuse insert, ensure that you do not damage any signal cables or plastic parts.

You can then replace the DC fuses.

Installation steps

To reinstall, perform the above steps in reverse order.

Note

Pay attention to the tightening torques

The tightening torques specified in the table "Tightening torques for screw connections" must be observed.

10.4.27 Replacing the DC fuses, Smart Line Module, Active Line Module, and Motor Module, frame size JX

Replacing the DC fuses

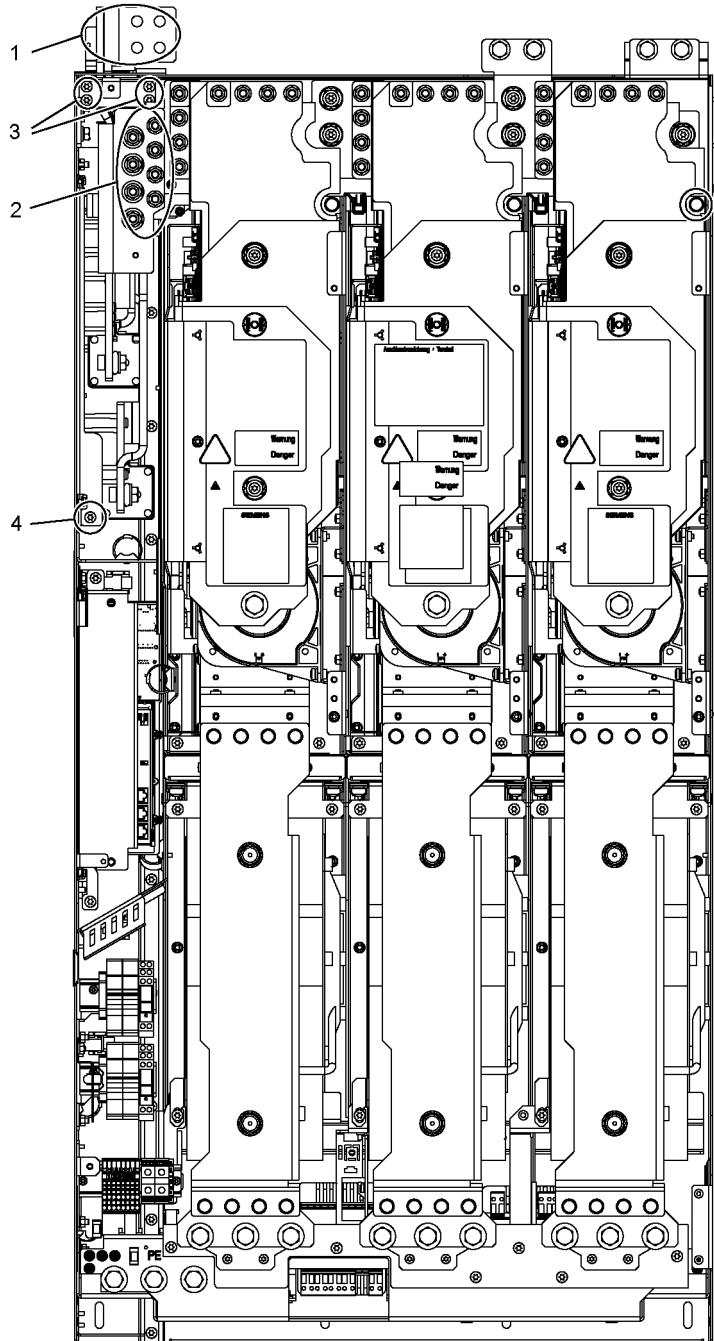

Figure 10-34 Replacing the DC fuses, Smart Line Module, Active Line Module, and Motor Module, frame size JX

Description

The DC fuses are installed in a fuse insert. To replace the fuses, the fuse insert be removed.

NOTICE

Device failure after a DC fuse trips

The neighboring DC fuses may also become damaged if a DC fuse trips. Failure to replace all fuses at the same time can cause the device to fail.

- After a DC fuse trips, always replace all DC fuses at the same time. Always use fuses of the same type.

Preparatory steps

- Disconnect the drive line-up from the power supply
- Allow unimpeded access
- Remove the protective cover

Removal

The removal steps are numbered in accordance with the numbers in the diagram.

1. Release the DC connections at DCP and DCN (four screws each)
2. Remove nuts (eight screws)
3. Remove the retaining screws for the connection plate of the housing (four screws) and remove the connection plate
4. Remove the retaining screw for the fuse insert (one screw)

You can now remove the fuse insert.

NOTICE

Damage to the device if signal cables or plastic parts become damaged during removal

Signal cables or plastic parts can become damaged when the fuse insert is removed. This can cause the device to fail.

- When removing the fuse insert, ensure that you do not damage any signal cables or plastic parts.

You can then replace the DC fuses.

Installation steps

To reinstall, perform the above steps in reverse order.

Note

Pay attention to the tightening torques

The tightening torques specified in the table "Tightening torques for screw connections" must be observed.

10.4.28 Replacing the fan fuses (-F10/-F11)

Article numbers for replacing fan fuses that have ruptured can be found in the spare parts list.

Note

Removing fault causes

Make sure that the cause of the fault is found before the fuse is replaced.

10.5 Forming the DC link capacitors

Description

If the Basic Line Module, Smart Line Module, Active Line Module, and Motor Module have not been used for more than two years, the DC-link capacitors must be reformed. If this is not carried out, the units could be damaged when the DC-link voltage is connected under load.

If the cabinet is commissioned within two years of its date of manufacture, the DC-link capacitors do not need to be re-formed. The date of manufacture can be taken from the serial number on the rating plate.

Note

Storage period

It is important that the storage period is calculated from the date of manufacture and not from the date that the equipment was shipped.

Rating plate

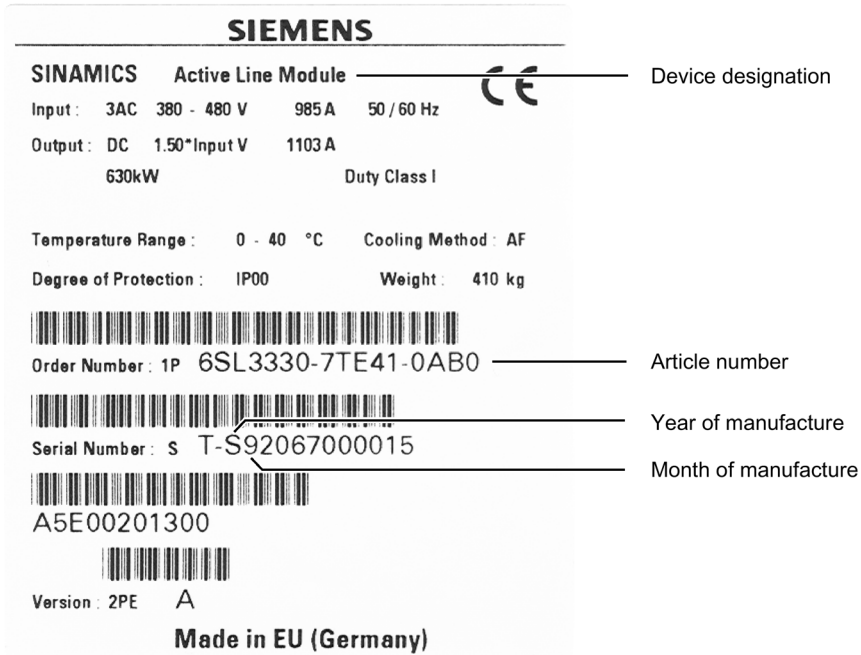

Figure 10-35 Rating plate using an Active Line Module as example

Date of manufacture

The date of manufacture can be determined as follows:

Table 10- 2 Production year and month

Character	Year of manufacture	Character	Month of manufacture
A	2010	1 ... 9	January to September
B	2011	O	October
C	2012	N	November
D	2013	D	December
E	2014		
F	2015		
H	2016		
J	2017		
K	2018		
L	2019		
M	2020		

Procedure in the event of repair or replacement

A replacement Line Module or Motor Module or the corresponding replacement power block has to be re-formed after being in storage for a period of more than two years.

The DC-link capacitors are re-formed by applying the rated voltage without load for at least 30 minutes.

To do this, the DC link must be precharged (i.e. the Line Modules switched on), while the controller for the existing Motor Modules must not be enabled for the specified length of time.

Procedure for re-forming outside the drive line-up

Replacement power units which have to be held ready for immediate use in the event of repair or replacement can also be re-formed individually and outside the drive line-up.

For this, the equipment must be connected to the forming circuits described in the following.

Components for the forming circuit (recommendation)

- One fuse switch 3 AC 400 V / 10 A or 690 V / 10 A
- Three incandescent lamps 230 V / 100 W for a line voltage of 3 AC 380 to 480 V. Alternatively, use three resistors of 1 k Ω / 100 W each (e.g. GWK150J1001KLX000 from Vishay) instead of the incandescent lamps.
- Six incandescent lamps 230 V / 100 W for a line voltage of 3 AC 500 to 690 V, where two incandescent lamps must be connected in series in each supply phase. Alternatively, use three resistors of 1 k Ω / 160 W each (e.g. GWK200J1001KLX000 from Vishay) instead of the incandescent lamps.
- Various small components, such as lamp sockets, cable 1.5 mm², etc.



WARNING

Electric shock when lamp sockets are installed so that they are not insulated

If two incandescent lamps connected in series are used, the insulation of the lamp sockets is not designed for a high voltage of 3 AC 500 to 690 V. Touching live parts can result in death or serious injury.

- For a line voltage of 500 to 690 V 3-ph AC, install the two lamp sockets connected in series so that they are carefully insulated - and protect them so that they cannot be touched.

Forming circuit for Line Modules

Note

Forming the Line Modules

Voltage must be supplied to Line Modules via a connected Motor Module and the associated DC link.

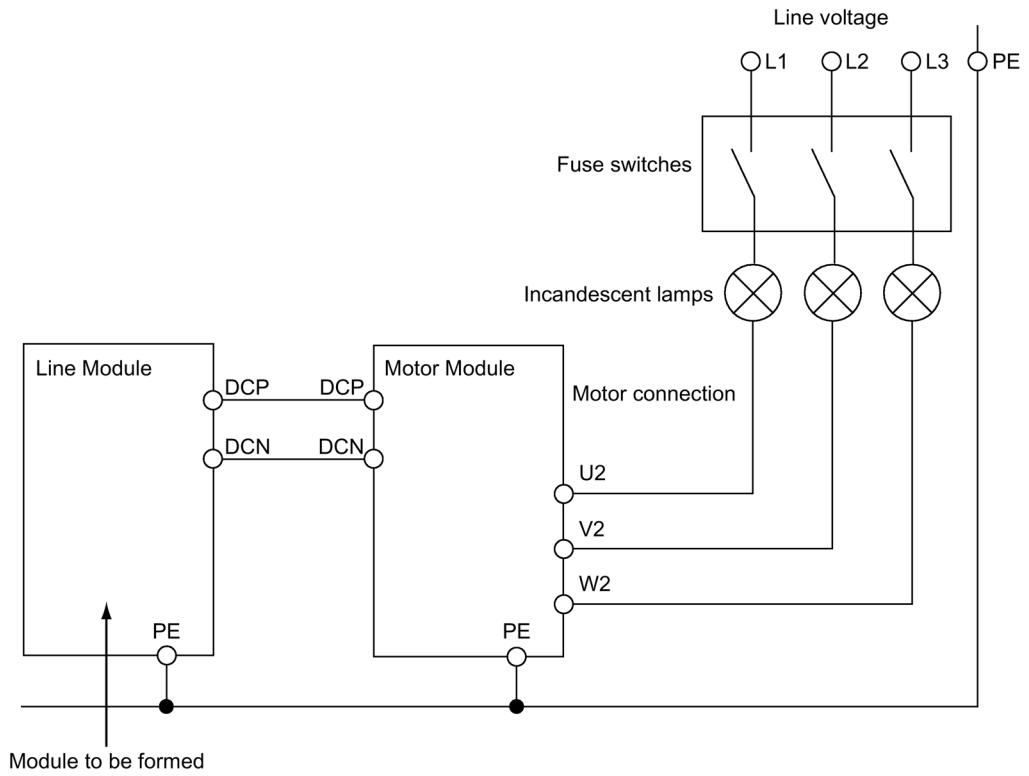

Figure 10-36 Forming circuit for Line Modules

Forming circuit for Motor Modules

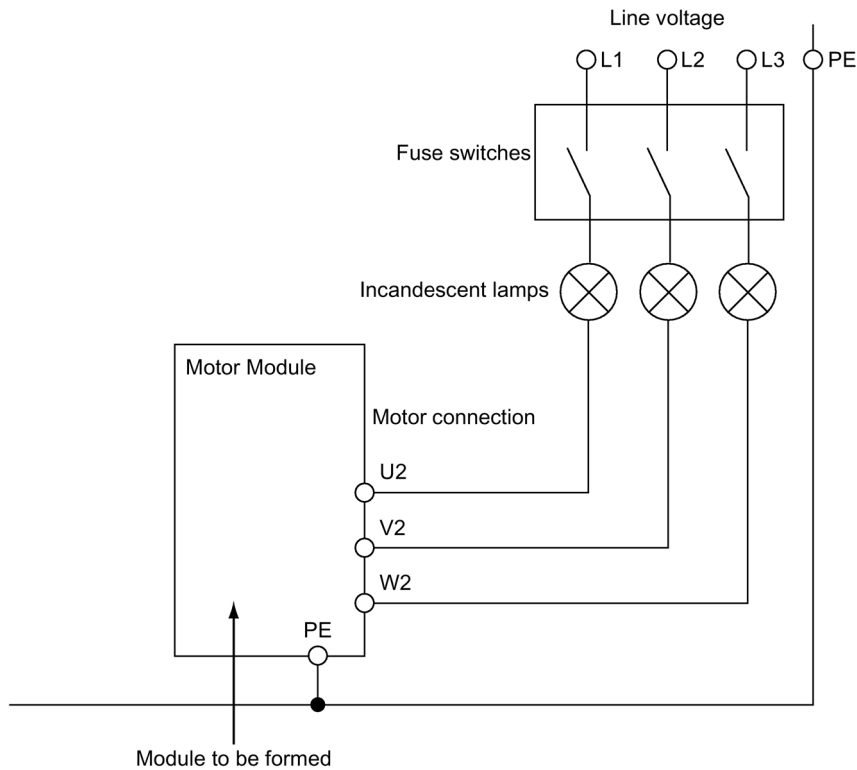

Figure 10-37 Forming circuit for Motor Modules

Procedure

- It is not permissible that the device being formed receives a power-on command (e.g. from the keyboard, BOP20 or terminal block).
- Connect the appropriate forming circuit.
- Forming has been completed if the DC link voltage no longer increases.

Maintaining the operational readiness of individual power blocks for servicing

It is recommended that during the planned downtimes, the power blocks positioned on the line side are replaced in order to guarantee the correct functioning of the power blocks during servicing.

Appendix

A.1 Cable lugs

Cable lugs

The cable connections on the devices are designed for cable lugs according to DIN 46234 or DIN 46235.

For connection of alternative cable lugs, the maximum dimensions are listed in the table below.

These cable lugs are not to exceed these dimensions, as mechanical fastening and adherence to the voltage distances is not guaranteed otherwise.

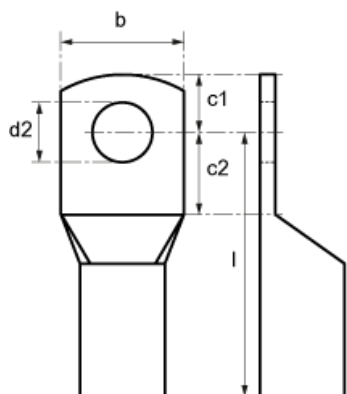

Figure A-1 Dimensions of the cable lugs

Table A- 1 Dimensions of the cable lugs

Screw / bolts	Connection cross-section [mm ²]	d2 [mm]	b [mm]	l [mm]	c1 [mm]	c2 [mm]
M8	70	8.4	24	55	13	10
M10	185	10.5	37	82	15	12
M10	240	13	42	92	16	13
M12	95	13	28	65	16	13
M12	185	13	37	82	16	13
M12	240	13	42	92	16	13
M16	240	17	42	92	19	16

A.2 List of abbreviations

Table A-2 List of abbreviations

Abbreviation	Meaning, German	Meaning, English
A		
A...	Warnung	Alarm
AC	Wechselstrom	Alternating Current
ADC	Analog-Digital-Konverter	Analog Digital Converter
AI	Analogeingang	Analog Input
AO	Analogausgang	Analog Output
AOP	Advanced Operator Panel	Advanced Operator Panel
ASCII	Amerikanische Code-Norm für den Informationsaustausch	American Standard Code for Information Interchange
B		
BB	Betriebsbedingung	Operating condition
BERO	Firmenname für einen Näherungsschalter	Tradename for a type of proximity switch
BI	Binektoreingang	Binector Input
BIA	Berufsgenossenschaftliches Institut für Arbeitssicherheit	Berufsgenossenschaftliches Institut für Arbeitssicherheit (German Institute for Occupational Safety)
BICO	Binektor-Konnektor-Technologie	Binector Connector Technology
BOP	Basic Operator Panel	Basic Operator Panel
C		
C	Kapazität	Capacity
CAN	Serielles Bussystem	Controller Area Network
CBC	Kommunikationsbaugruppe CAN	Communication Board CAN
CBP	Kommunikationsbaugruppe PROFIBUS	Communication Board PROFIBUS
CD	Compact Disc	Compact Disc
CDS	Befehlsdatensatz	Command Data Set
CI	Konnektoreingang	Connector Input
CIB	Control Interface Board	Control Interface Board
CNC	Computerunterstützte numerische Steuerung	Computer Numerical Control
CO	Konnektorausgang	Connector Output
CO/BO	Konnektor-/Binektorausgang	Connector/Binector Output
COM	Mittelkontakt eines Wechselkontaktes	Medium contact of a change-over contact
CP	Kommunikationsprozessor	Communications Processor
CPU	Zentralbaugruppe	Central Processing Unit
CRC	Checksummenprüfung	Cyclic Redundancy Check
CT	Konstantes Drehmoment	Constant Torque
CU	Control Unit	Control Unit
D		
DAC	Digital-Analog-Konverter	Digital Analog Converter
DC	Gleichstrom	Direct Current

Abbreviation	Meaning, German	Meaning, English
DCN	Gleichstrom negativ	Direct current negative
DCNA	Gleichstrom negativ Zusatzanschluss	Direct current negative auxiliary
DCP	Gleichstrom positiv	Direct current positive
DCPA	Gleichstrom negativ Zusatzanschluss	Direct current positive auxiliary
DDS	Antriebsdatensatz	Drive Data Set
DI	Digitaleingang	Digital Input
DI / DO	Digitaleingang/-ausgang bidirektional	Bidirectional Digital Input/Output
DMC	DRIVE-CLiQ Module Cabinet (Hub)	DRIVE-CLiQ Module Cabinet (Hub)
DO	Digitalausgang	Digital Output
DO	Antriebsobjekt	Drive Object
DPRAM	Speicher mit beidseitigem Zugriff	Dual-Port Random Access Memory
DRAM	Dynamischer Speicher	Dynamic Random Access Memory
DRIVE-CLiQ	Drive Component Link with IQ	Drive Component Link with IQ
DSC	Dynamic Servo Control	Dynamic Servo Control
E		
EDS	Geberdatensatz	Encoder Data Set
EMV	Elektromagnetische Verträglichkeit	Electromagnetic Compatibility (EMC)
EN	Europäische Norm	European Standard
EnDat	Geber-Schnittstelle	Encoder-Data-Interface
EP	Impulsfreigabe	Enable Pulses
ES	Engineering System	Engineering System
ESD	Elektrostatisch gefährdete Baugruppen	Electrostatic Sensitive Devices (ESD)
F		
F ...	Störung	Fault
FAQ	Häufig gestellte Fragen	Frequently Asked Questions
FCC	Function Control Chart	Function Control Chart
FCC	Flussstromregelung	Flux Current Control
FEPROM	Schreib- und Lesespeicher nichtflüchtig	Flash-EPROM
FG	Funktionsgenerator	Function Generator
FI	Fehlerstrom-Schutzschalter	Earth Leakage Circuit-Breaker (ELCB)
Float	Gleitkommazahl	Floating point
FP	Funktionsplan	Function diagram
FW	Firmware	Firmware
G		
GCP	Global-Control-Telegramm (Broadcast-Telegramm)	Global Control Telegram (broadcast telegram)
GSD	Gerätstammdatei: beschreibt die Merkmale eines PROFIBUS-Slaves	Device master file: describes the features of a PROFIBUS slave
H		
HLG	Hochlaufgeber	Ramp-function generator
HMI	Mensch-Maschine-Schnittstelle	Human Machine Interface
HTL	Hochpegellogik	High Threshold Logic

Abbreviation	Meaning, German	Meaning, English
HW	Hardware	Hardware
I		
i. V.	in Vorbereitung: diese Eigenschaft steht zur Zeit nicht zur Verfügung	in preparation: this feature is currently not available
I/O	Eingang/Ausgang	Input/Output
IBN	Inbetriebnahme	Commissioning
ID	Identifizierung	Identifier
IEC	Internationale Norm in der Elektrotechnik	International Electrotechnical Commission
IGBT	Bipolartransistor mit isolierter Steuerelektrode	Insulated Gate Bipolar Transistor
IT	Drehstromversorgungsnetz ungeerdet	three-phase supply network, ungrounded
J		
JOG	Tippen	Jogging
K		
KDV	Kreuzweiser Datenvergleich	Data cross-checking
KIP	Kinetische Pufferung	Kinetic buffering
KTY	Spezieller Temperatursensor	Special temperature sensor
L		
L	Inductance	Inductance
LED	Leuchtdiode	Light Emitting Diode
LSB	Niederwertigstes Bit	Least Significant Bit
M		
M	Masse	reference potential, zero potential
MB	Megabyte	Megabyte
MCC	Motion Control Chart	Motion Control Chart
MDS	Motordatensatz	Motor Data Set
MLFB	Machine-readable product designation	machine-readable product designation
MMC	Mensch Maschine Kommunikation	Man-Machine Communication
MSB	Höchstwertigstes Bit	Most Significant Bit
MSCY_C1	Zyklische Kommunikation zwischen Master (Klasse 1) und Slave	Master Slave Cycle Class 1
N		
NC	Öffner	Normally Closed (contact)
NC	Numerische Steuerung	Numerical Control
NEMA	Normengremium in USA (United States of America)	National Electrical Manufacturers Association
NM	Nullmarke	Zero Mark
NO	Schließer	Normally Open (contact)
O		
OEM	Original Equipment Manufacturer	Original Equipment Manufacturer
OLP	Busstecker für Lichtleiter	Optical Link Plug
OMI	Option Module Interface	Option Module Interface
P		
p ...	Einstellparameter	Adjustable parameter

Abbreviation	Meaning, German	Meaning, English
PDS	Leistungsteildatensatz	Power Module Data Set
PE	Schutzerde	Protective Earth
PELV	Schutzkleinspannung	Protective Extra Low Voltage
PG	Programmiergerät	Programming terminal
PI	Proportional Integral	Proportional Integral
PLC	Speicherprogrammierbare Steuerung (SPS)	Programmable Logic Controller (PLC)
PLL	Baustein zur Synchronisierung	Phase Locked Loop
PNO	PROFIBUS Nutzerorganisation	PROFIBUS user organization
PRBS	Weißes Rauschen	Pseudo Random Binary Signal
PROFIBUS	Serieller Datenbus	Process Field Bus
PS	Stromversorgung	Power Supply
PTC	Positiver Temperaturkoeffizient	Positive Temperature Coefficient
PTP	Punkt zu Punkt	Point To Point
PWM	Pulsweitenmodulation	Pulse Width Modulation
PZD	PROFIBUS Prozessdaten	PROFIBUS Process data
Q		
R		
r...	Beobachtungsparameter (nur lesbar)	Display Parameter (read only)
RAM	Speicher zum lesen und schreiben	Random Access Memory
RCD	Fehlerstrom-Schutzschalter	Residual Current Device
RJ45	Norm. Beschreibt eine 8-polige Steckverbindung mit Twisted-Pair Ethernet.	Standard. Describes an 8-pole plug connector with twisted pair Ethernet.
RO	Nur lesbar	Read Only
RS232	Serielle Schnittstelle	Serial Interface
RS485	Norm. Beschreibt die Physik einer digitalen seriellen Schnittstelle.	Standard. Describes the physical characteristics of a digital serial interface.
S		
S1	Dauerbetrieb	Continuous operation
S3	Aussetzbetrieb	periodic duty
SBC	Sichere Bremsenansteuerung	Safe Brake Control
SGE	Sicherheitsgerichtetes Eingangssignal	Safe input signal
SH	Sicherer Halt	Safe Standstill
SI	Safety Integrated	Safety Integrated
SIL	Sicherheitsintegritätsgrad	Safety Integrity Level
SLVC	Geberlose Vektorregelung	Sensorless Vector Control
SM	Sensor Module	Sensor Module
SMC	Sensor Module Cabinet	Sensor Module Cabinet
SME	Sensor Module External	Sensor Module External
SPS	Speicherprogrammierbare Steuerung	Programmable Logic Controller (PLC)
STW	PROFIBUS Steuerwort	PROFIBUS control word
T		
TB	Terminal Board	Terminal Board

Abbreviation	Meaning, German	Meaning, English
TIA	Totally Integrated Automation	Totally Integrated Automation
TM	Terminal Module	Terminal Module
TN	Drehstromversorgungsnetz geerdet	Three-phase supply network, grounded
TT	Drehstromversorgungsnetz geerdet	Three-phase supply network, grounded
TTL	Transistor-Transistor-Logik	Transistor-transistor logic
U		
UL	Underwriters Laboratories Inc.	Underwriters Laboratories Inc.
V		
VC	Vektorregelung	Vector Control
Vdc	Zwischenkreisspannung	DC link voltage
VDE	Verband Deutscher Elektrotechniker	Association of German Electrical Engineers
VDI	Verein Deutscher Ingenieure	Association of German Engineers
VSM	Voltage Sensing Module	Voltage Sensing Module
VT	Variables Drehmoment	Variable Torque
W		
WZM	Werkzeugmaschine	Machine tool
X		
XML	Erweiterbare Auszeichnungssprache (Standardsprache für Web-Publishing und Dokumentenmanagement)	Extensible Markup Language
Y		
Z		
ZK	Zwischenkreis	DC Link
ZSW	PROFIBUS Zustandswort	PROFIBUS status word

Index

A

- Active Interface Modules, 71
 - Dimension drawing, 83
- Active Line Modules, 161
 - Dimension drawing, 177

B

- Backup
 - Fan (-F10/-F11), 437
- Basic Line Modules, 98
 - Dimension drawing, 112
- Basic structure
 - and regulated infeed, 38
 - and unregulated infeed, 40
 - with unregulated infeed / regenerative feedback, 39
- Basic structure of a drive system with SINAMICS S120, 38
- Braking Module, 259
 - Braking resistor connection, 265
 - Installation, 269
 - S1 – Threshold switch, 267
 - X21 digital inputs/outputs, 266
- Braking resistors, 284
 - Dimension drawing, 287

C

- Cabinet design and EMC, 349
- Cable lugs, 443
- Cleaning, 366
- Connection
 - dV/dt filter compact plus voltage peak limiter, 335
 - dV/dt filter with voltage peak limiter, 315
- Connection example
 - Active Interface Modules, 77
 - Braking Module, 265
- Control cabinet design
 - Air conditioning, 352
 - Ventilation, 353
- Control Interface Module
 - Frame size FB, replacement, 405
 - Frame size FS4, replacing, 402
 - Frame size FX, replacement, 394
 - Frame size GX, replacement, 396

- Frame size HX, replacement, 398
- Frame size JX, replacement, 400
- Frame sizes GB, GD, replacement, 407

D

- Date of manufacture, 438
- DC fuses
 - Frame size HX, replacement, 432
 - Frame size JX, replacement, 435
- DC-link components
 - Braking Module, 259
 - Braking resistors, 284
- Derating factors
 - Current derating as a function of the pulse frequency, 229, 257
 - Function of installation altitude and ambient temperature, 33
- Dimension drawing
 - Active Interface Modules, 83
 - Active Line Modules, 177
 - Basic Line Modules, 112
 - Braking resistors, 287
 - dV/dt filter compact plus voltage peak limiter, 338
 - dV/dt reactor, 318
 - Line filters for Active Line Modules, 52
 - Line filters for Basic Line Modules, 45
 - Line filters for Smart Line Modules, 52
 - Line reactors for Basic Line Modules, 58
 - Line reactors for Smart Line Modules, 64
 - Motor Modules, 208
 - Motor Modules Chassis-2, 248
 - Motor reactors, 300
 - Sine-wave filter, 294
 - Smart Line Modules, 145
 - Voltage peak limiter, 321
- Disconnect the basic interference suppression module, 87, 114, 148
- dV/dt filter, 308
 - Interfaces, 313
- dV/dt filter compact plus Voltage Peak Limiter, 328
 - Connection, 335
 - Dimension drawing, 338
 - Interfaces, 333
- dV/dt filter with voltage peak limiter
 - Connection, 315
- dV/dt reactor
 - Dimension drawing, 318

E

- Electromagnetic fields, 17
- Electronic fan
 - Frame size FS4, replacing, 419
- Electrostatic sensitive devices, 20
- EMC
 - General information, 349

F

- Fan
 - Frame size FI, replacement, 422
 - Frame size FS4, replacing, 417
 - Frame size GI, replacement, 424
 - Frame size HI, replacement, 426
 - Frame size HX, replacement, 411
 - Frame size JI, replacement, 428
 - Frame size JX, replacement, 415
 - Frame sizes FB, GB, GD, replacement, 430
 - Frame sizes FX and GX, replacement, 409
- Fan voltage
 - Active Line Modules, 181
 - Basic Line Modules, 117
 - Motor Modules, 212
 - Smart Line Modules, 152
- Forming the DC link capacitors, 437
- Fundamental safety instructions
 - SINAMICS hardware, 15

H

- Hotline, 5

I

- Installation
 - Motor Modules Chassis-2, 249
- Installation device, 368
- Interfaces
 - Active Interface Modules, 73
 - Basic Line Modules, 102
 - Braking Module, 262
 - dV/dt filter, 313
 - dV/dt filter compact plus Voltage Peak Limiter, 333
 - Smart Line Modules, 136
- IT system, 87, 114, 148

L

- LEDs
 - Active Interface Modules, 82
 - Active Line Modules, 176
 - Basic Line Modules, 111
 - Motor Modules, 207, 247
 - Smart Line Modules, 144
- Line filters for Active Line Modules, 49
 - Dimension drawing, 52
- Line filters for Basic Line Modules, 41
 - Dimension drawing, 45
- Line filters for Smart Line Modules, 49
 - Dimension drawing, 52
- Line Modules, 97
 - Active Line Modules, 161
 - Basic Line Modules, 98
 - Smart Line Modules, 130
- Line reactors for Basic Line Modules, 56
 - Dimension drawing, 58
- Line reactors for Smart Line Modules, 62
 - Dimension drawing, 64
- Line-side power components, 41
 - Active Interface Modules, 71
 - Line filters for Active Line Modules, 49
 - Line filters for Basic Line Modules, 41
 - Line filters for Smart Line Modules, 49
 - Line reactors for Basic Line Modules, 56
 - Line reactors for Smart Line Modules, 62
- List of abbreviations, 444

M

- Maintenance, 366, 367
- Maintenance and servicing, 365
- Maximum cable lengths, 351
- Motor Modules, 193, 233
 - Dimension drawing, 208
 - Minimum cable length, 232
 - Parallel connection, 231
- Motor Modules Chassis-2
 - Dimension drawing, 248
 - Installation, 249
 - Minimum cable length, 258
 - Parallel connection, 258
 - PE connections, 250
 - Shield connections, 251
- Motor reactors, 296
 - Dimension drawing, 300
- Motor-side power components, 291
 - dV/dt filter, 308
 - dV/dt filter compact plus Voltage Peak Limiter, 328

Motor reactors, 296
Sine-wave filter, 291

N

Non-grounded system, 87, 114, 148

O

Operation on a non-grounded system, 87, 114, 148
Overload capability Basic Line Modules, 129
 High overload, 129
Overload capability of Active Line Modules, 191
 High overload, 191
Overload capability of the Motor Modules, 227
 High overload, 228
 Low overload, 228
Overload capability, Motor Modules Chassis-2, 254
 High overload, 255
 Low overload, 255
 S6 duty cycle, 256
Overload reserve for Smart Line Modules, 160
 High overload, 160

P

Parallel connection
 Motor Modules, 231
 Motor Modules Chassis-2, 258
Power block
 Crane lifting lugs, 369
 Frame size FB, replacement, 388
 Frame size FX, replacement, 375
 Frame size GX, replacement, 378
 Frame size HX, replacement, 381
 Frame size JX, replacement, 386
 Frame sizes GB, GD, replacement, 391

R

Rating plate, 438
Replacement
 Automatic firmware update, 374
 Control Interface Module, frame sizes GB, GD, 407
 Error messages, 373
Replacing
 Control Interface Module, frame size FB, 405
 Control Interface Module, frame size FS4, 402
 Control Interface Module, frame size FX, 394
 Control Interface Module, frame size GX, 396

Control Interface Module, frame size HX, 398
Control Interface Module, frame size JX, 400
Crane lifting lugs, 369
DC fuses, frame size HX, 432
DC fuses, frame size JX, 435
Electronic fan, frame size FS4, 419
Fan, frame size FI, 422
Fan, frame size FS4, 417
Fan, frame size GI, 424
Fan, frame size HI, 426
Fan, frame size HX, 411
Fan, frame size JX, 415, 428
Fan, frame sizes FB, GB, GD, 430
Fan, frame sizes FX and GX, 409
Installation device, 368
Power block, frame size FB, 388
Power block, frame size FX, 375
Power block, frame size GX, 378
Power block, frame size HX, 381
Power block, frame size JX, 386
Power block, frame sizes GB, GD, 391
Replacing components, 373
Residual risks, 22

S

Safety information
 Active Interface Modules, 72
 Active Line Modules, 164
 Basic Line Modules, 100
 Braking Modules, 261
 Braking resistors, 285
 dV/dt filter compact plus Voltage Peak Limiter, 330
 EMC, 350
 Line filters for Active Line Modules, 49
 Line filters for Basic Line Modules, 42
 Line filters for Smart Line Modules, 49
 Line reactors for Basic Line Modules, 56
 Line reactors for Smart Line Modules, 62
 Motor Modules, 195, 235
 Motor reactors, 298
 Sine-wave filter, 292
 Smart Line Modules, 133
Safety instructions
 Control cabinet design, 350
 dV/dt filter plus Voltage Peak Limiter, 310
 Electromagnetic fields, 17
 Electrostatic sensitive devices, 20
 General safety instructions, 15
 Maintenance and servicing, 365
Sine-wave filter, 291
 Dimension drawing, 294

- Smart Line Modules, 130
 - Dimension drawing, 145
- Standards, 35
- Support, 5
- System overview, 23

T

Technical data

- Active Interface Modules, 93
- Active Line Modules, 183
- Basic Line Modules, 121
- Braking Modules, 281
- Braking resistors, 288
- Derating factors, 33
- dV/dt filter compact plus voltage peak limiter, 343
- dV/dt filter plus voltage peak limiter, 325
- dV/dt filter plus voltage peak limiter, 324
- General technical data, 30
- Line filters for Active Line Modules, 55
- Line filters for Basic Line Modules, 47
- Line filters for Smart Line Modules, 55
- Line reactors for Basic Line Modules, 60
- Line reactors for Smart Line Modules, 70
- Motor Modules, 214
- Motor Modules Chassis-2, 253
- Motor reactors, 304
- Sine-wave filter, 295
- Smart Line Modules, 154

Technical support, 5

Tightening torques, 367

Tool, 367

V

- Voltage peak limiter
 - Dimension drawing, 321

Further information

Siemens:

www.siemens.com

Industry Online Support (service and support):

www.siemens.com/online-support

IndustryMall:

www.siemens.com/industrymall

Siemens AG

Process Industries and Drives

Large Drives

Postbox 4743

90025 Nuremberg

Germany

Scan the QR-Code
for product
information

