

**SIEMENS**

# SINAMICS

SINAMICS S120 Combi

Equipment Manual

Edition

07/2016



# SIEMENS

## SINAMICS

### S120 SINAMICS S120 Combi

Manual

#### Preface

---

Fundamental safety instructions 1

---

System overview 2

---

Line-side power components 3

---

S120 Combi Power Modules 4

---

Topology rules for DRIVE-CLiQ 5

---

Motor Modules Booksize Compact as expansion axes 6

---

DC link components 7

---

Electrically connecting Motor Modules and DC link components 8

---

Additional system components 9

---

Encoder system connection 10

---

Accessories 11

---

Cabinet design and EMC 12

---

Service and maintenance 13

---

Appendix A

---

(GH9),  
07/2016

6SL3097-4AV00-0BP5

## Legal information

### Warning notice system

This manual contains notices you have to observe in order to ensure your personal safety, as well as to prevent damage to property. The notices referring to your personal safety are highlighted in the manual by a safety alert symbol, notices referring only to property damage have no safety alert symbol. These notices shown below are graded according to the degree of danger.

 <b>DANGER</b>
indicates that death or severe personal injury <b>will</b> result if proper precautions are not taken.

 <b>WARNING</b>
indicates that death or severe personal injury <b>may</b> result if proper precautions are not taken.

 <b>CAUTION</b>
indicates that minor personal injury can result if proper precautions are not taken.

<b>NOTICE</b>
indicates that property damage can result if proper precautions are not taken.

If more than one degree of danger is present, the warning notice representing the highest degree of danger will be used. A notice warning of injury to persons with a safety alert symbol may also include a warning relating to property damage.

### Qualified Personnel

The product/system described in this documentation may be operated only by **personnel qualified** for the specific task in accordance with the relevant documentation, in particular its warning notices and safety instructions. Qualified personnel are those who, based on their training and experience, are capable of identifying risks and avoiding potential hazards when working with these products/systems.

### Proper use of Siemens products

Note the following:

 <b>WARNING</b>
Siemens products may only be used for the applications described in the catalog and in the relevant technical documentation. If products and components from other manufacturers are used, these must be recommended or approved by Siemens. Proper transport, storage, installation, assembly, commissioning, operation and maintenance are required to ensure that the products operate safely and without any problems. The permissible ambient conditions must be complied with. The information in the relevant documentation must be observed.

### Trademarks

All names identified by ® are registered trademarks of Siemens AG. The remaining trademarks in this publication may be trademarks whose use by third parties for their own purposes could violate the rights of the owner.

### Disclaimer of Liability

We have reviewed the contents of this publication to ensure consistency with the hardware and software described. Since variance cannot be precluded entirely, we cannot guarantee full consistency. However, the information in this publication is reviewed regularly and any necessary corrections are included in subsequent editions.

# Preface

## SINAMICS documentation

The SINAMICS documentation is organized in the following categories:

- General documentation/catalogs
- User documentation
- Manufacturer/service documentation

## Additional information

You can find information on the following topics at the following address (<https://support.industry.siemens.com/cs/de/en/view/108993276>):

- Ordering documentation/overview of documentation
- Additional links to download documents
- Using documentation online (find and search in manuals/information)

Please send any questions about the technical documentation (e.g. suggestions for improvement, corrections) to the following e-mail address (<mailto:docu.motioncontrol@siemens.com>).

## Siemens MySupport/Documentation

At the following address (<https://support.industry.siemens.com/My/ww/en/documentation>), you can find information on how to create your own individual documentation based on Siemens' content, and adapt it for your own machine documentation.

## Training

At the following address (<http://www.siemens.com/sitrain>), you can find information about SITRAIN (Siemens training on products, systems and solutions for automation and drives).

## FAQs

You can find Frequently Asked Questions in the Service&Support pages under Product Support (<https://support.industry.siemens.com/cs/de/en/ps/faq>).

## SINAMICS

You can find information about SINAMICS at the following address (<http://www.siemens.com/sinamics>).

## Usage phases and their documents/tools (as an example)

Table 1 Usage phases and the available documents/tools

Usage phase	Document/tool
Orientation	SINAMICS S Sales Documentation
Planning/configuration	<ul style="list-style-type: none"> <li>• SIZER Engineering Tool</li> <li>• Configuration Manuals, Motors</li> </ul>
Deciding/ordering	SINAMICS S120 catalogs <ul style="list-style-type: none"> <li>• SIMOTION, SINAMICS S120 and Motors for Production Machines (Catalog PM 21)</li> <li>• SINAMICS and Motors for Single-axis Drives (Catalog D 31)</li> <li>• SINUMERIK &amp; SINAMICS Equipment for Machine Tools (Catalog NC 61)</li> <li>• SINUMERIK 840D sl Type 1B Equipment for Machine Tools (Catalog NC 62)</li> </ul>
Installation/assembly	<ul style="list-style-type: none"> <li>• SINAMICS S120 Manual for Control Units and Additional System Components</li> <li>• SINAMICS S120 Manual for Booksize Power Units</li> <li>• SINAMICS S120 Manual for Booksize Power Units C/D Type</li> <li>• SINAMICS S120 Manual for Chassis Power Units, Air-cooled</li> <li>• SINAMICS S120 Manual for Chassis Power Units, Liquid-cooled</li> <li>• SINAMICS S120 Manual for AC Drives</li> <li>• SINAMICS S120 Manual Combi</li> <li>• SINAMICS S120M Manual Distributed Drive Technology</li> <li>• SINAMICS HLA System Manual Hydraulic Drive</li> </ul>
Commissioning	<ul style="list-style-type: none"> <li>• STARTER Commissioning Tool</li> <li>• SINAMICS S120 Getting Started with STARTER</li> <li>• SINAMICS S120 Commissioning Manual with STARTER</li> <li>• SINAMICS S120 CANopen Commissioning Manual</li> <li>• SINAMICS S120 Function Manual Drive Functions</li> <li>• SINAMICS S120 Safety Integrated Function Manual</li> <li>• SINAMICS S120/S150 List Manual</li> <li>• SINAMICS HLA System Manual Hydraulic Drive</li> <li>• Startdrive commissioning tool<sup>1)</sup></li> <li>• SINAMICS S120 Getting Started with Startdrive<sup>1)</sup></li> <li>• SINAMICS S120 Commissioning Manual with Startdrive<sup>1)</sup></li> </ul>
Usage/operation	<ul style="list-style-type: none"> <li>• SINAMICS S120 Commissioning Manual with STARTER</li> <li>• SINAMICS S120/S150 List Manual</li> <li>• SINAMICS HLA System Manual Hydraulic Drive</li> <li>• SINAMICS S120 Commissioning Manual with Startdrive<sup>1)</sup></li> </ul>

Usage phase	Document/tool
Maintenance/servicing	<ul style="list-style-type: none"> <li>• SINAMICS S120 Commissioning Manual with STARTER</li> <li>• SINAMICS S120/S150 List Manual</li> <li>• SINAMICS S120 Commissioning Manual with Startdrive<sup>1)</sup></li> </ul>
References	<ul style="list-style-type: none"> <li>• SINAMICS S120/S150 List Manual</li> </ul>

<sup>1)</sup> available as of Startdrive V14 release

## Target group

This documentation is intended for machine manufacturers, commissioning engineers, and service personnel who use the SINAMICS drive system.

## Benefits

This manual provides all of the information, procedures and operator actions required for the particular usage phase.

## Standard scope

The scope of the functionality described in this document can differ from that of the drive system that is actually supplied.

- Other functions not described in this documentation might be able to be executed in the drive system. However, no claim can be made regarding the availability of these functions when the equipment is first supplied or in the event of service.
- The documentation can also contain descriptions of functions that are not available in a particular product version of the drive system. The functionality of the supplied drive system should only be taken from the ordering documentation.
- Extensions or changes made by the machine manufacturer must be documented by the machine manufacturer.

For reasons of clarity, this documentation does not contain all of the detailed information on all of the product types, and cannot take into consideration every conceivable type of installation, operation and service/maintenance.

## Technical Support

Country-specific telephone numbers for technical support are provided in the Internet at the following address (<https://support.industry.siemens.com/sc/ww/en/sc/2090>) in the "Contact" area.

## See also

EC-conform (<https://support.industry.siemens.com/cs/ww/en/ps/13231/cert>)

UL certificate (<http://database.ul.com/cgi-bin/XYV/template/LISEXT/1FRAME/index.html>)

TÜV-Süd ([https://www.tuev-sued.de/industry\\_and\\_consumer\\_products/certificates](https://www.tuev-sued.de/industry_and_consumer_products/certificates))

## Relevant directives and standards

You can obtain an up-to-date list of currently certified components on request from your local Siemens office. If you have any questions relating to certifications that have not yet been completed, please ask your Siemens contact person.

### Certificates for download

The certificates can be downloaded from the Internet:

Certificates



### EC Declaration of Conformity

You can find the EC Declaration of Conformity for the relevant directives as well as the relevant certificates, prototype test certificates, manufacturers declarations and test certificates for functions relating to functional safety ("Safety Integrated") on the Internet at the following address.

The following directives and standards are relevant for SINAMICS S devices:

### European low-voltage directive

SINAMICS S devices fulfil the requirements stipulated in the Low-Voltage Directive 2014/35/EU, insofar as they are covered by the application area of this directive.

### European machinery directive

SINAMICS S devices fulfil the requirements stipulated in the Low-Voltage Directive 2006/42/EU, insofar as they are covered by the application area of this directive.

However, the use of the SINAMICS S devices in a typical machine application has been fully assessed for compliance with the main regulations in this directive concerning health and safety.

### European EMC Directive

SINAMICS S devices comply with the EMC Directive 2014/30/EU.



### EMC requirements for South Korea

SINAMICS S devices with the KC marking on the rating plate satisfy the EMC requirements for South Korea.

### Specification for semiconductor process equipment voltage drop immunity

SINAMICS S devices meet the requirements of standard SEMI F47-0706.



### Eurasian conformity

SINAMICS S comply with the requirements of the Russia/Belarus/Kazakhstan customs union (EAC).



### North American market

SINAMICS S devices provided with one of the test symbols displayed fulfil the requirements stipulated for the North American market as a component of drive applications.



You can find the relevant certificates on the Internet pages of the certifiers:

- For products with UL certificate
- For products with TÜV SÜD certificate

#### Possible test symbols



#### Australia and New Zealand (RCM formerly C-Tick)

SINAMICS S devices showing the test symbols fulfil the EMC requirements for Australia and New Zealand.

#### Quality systems

Siemens AG employs a quality management system that meets the requirements of ISO 9001 and ISO 14001.

#### Not relevant standards



#### China Compulsory Certification

SINAMICS S devices do not fall in the area of validity of the China Compulsory Certification (CCC).

#### EMC limit values in South Korea

이 기기는 업무용(A급) 전자파적합기기로서 판매자 또는 사용자는 이 점을 주의하시기 바라며, 가정외의 지역에서 사용하는 것을 목적으로 합니다.  
For sellers or other users, please bear in mind that this device is an A-grade electromagnetic wave device. This device is intended to be used in areas other than at home.

The EMC limit values to be observed for Korea correspond to the limit values of the EMC product standard for variable-speed electric drives EN 61800-3 of category C2 or the limit value class A, Group 1 to KN11. By implementing appropriate additional measures, the limit values according to category C2 or limit value class A, Group 1, are observed. Further, additional measures may be required, such as using an additional radio interference suppression filter (EMC filter).

The measures for EMC-compliant design of the system are described in detail in this manual respectively in the EMC Installation Guideline Configuration Manual.

The final statement regarding compliance with the standard is given by the respective label attached to the individual unit.

## Ensuring reliable operation

The manual describes a desired state which, if maintained, ensures the required level of operational reliability and compliance with EMC limit values.

Should there be any deviation from the requirements in the manual, appropriate actions (e.g. measurements) must be taken to check/prove that the required level of operational reliability and compliance with EMC limit values are ensured.

## Spare parts

Spare parts are available on the Internet at the following address (<https://www.automation.siemens.com/sow?sap-language=EN>).

## Product maintenance

The components are subject to continuous further development within the scope of product maintenance (improvements to robustness, discontinuations of components, etc).

These further developments are "spare parts-compatible" and do not change the article number.

In the scope of such spare parts-compatible further developments, connector positions are sometimes changed slightly. This does not cause any problems with proper use of the components. Please take this fact into consideration in special installation situations (e.g. allow sufficient clearance for the cable length).

## Use of third-party products



This document contains recommendations relating to third-party products. Siemens accepts the fundamental suitability of these third-party products.

You can use equivalent products from other manufacturers.

Siemens does not accept any warranty for the properties of third-party products.

## Ground symbols

Table 2 Symbols

Symbol	Meaning
	Connection for protective conductor (PE)
	Ground (e.g. M 24 V)
	Connection for function potential bonding

## Testing the protection against electric shock when using frequency converters

Protection on indirect contact in the motor circuit of a converter and automatic disconnection in case of a fault in accordance with DIN EN 60364-4-41 VDE 0100, part 410 is ensured if the following conditions are met:

- The installation instructions provided in the documentation of the converter have been followed, in particular, regarding
  - Equipotential bonding
  - Conductor cross section
  - Fuse protection
- The valid standards were complied with during installation:
  - DIN EN 50178 VDE 0160
  - DIN EN 60204-1 VDE 0113, part 1
  - DIN EN 60364-5-52 VDE 0100-520
  - DIN EN 60364-5-54 VDE 0100-540
- Continuity of the PE conductor is ensured according to DIN VDE 0100-600 (IEC 60364-6)

Converters of the SINAMICS series meet the requirements defined in DIN EN 60364-4-41 VDE 0100, part 410 and comply with the specified break times.

### Background

In the case of a short-circuit with negligible impedance to ground, the converter interrupts the circuit within the shortest time ( $\ll 100$  ms). As a consequence, there is very high impedance between the converter DC link and the output ( $> 1$  M $\Omega$ ) so that the possible voltage as result of the voltage divider with the impedance of the ground connection between the motor and converter is less than 50 VAC or 120 VDC.



# Table of contents

	<b>Preface</b> .....	<b>5</b>
<b>1</b>	<b>Fundamental safety instructions</b> .....	<b>21</b>
1.1	General safety instructions .....	21
1.2	Safety instructions for electromagnetic fields (EMF) .....	25
1.3	Handling electrostatic sensitive devices (ESD) .....	25
1.4	Industrial security .....	26
1.5	Residual risks of power drive systems.....	27
<b>2</b>	<b>System overview</b> .....	<b>29</b>
2.1	SINAMICS S120 Combi components .....	29
2.2	System data .....	32
2.3	Derating as a function of the installation altitude and ambient temperature.....	34
<b>3</b>	<b>Line-side power components</b> .....	<b>37</b>
3.1	Introduction .....	37
3.2	Information on the disconnecter unit.....	38
3.3	Overcurrent protection by means of line fuses and circuit breakers .....	38
3.4	Line supply connection via residual-current devices .....	40
3.5	Overvoltage protection.....	42
3.6	Line filters.....	43
3.6.1	Description .....	43
3.6.2	Safety information .....	44
3.6.3	Interface description.....	46
3.6.3.1	Overview .....	46
3.6.3.2	Line/load connection .....	47
3.6.4	Dimension drawing .....	47
3.6.5	Technical data.....	48
3.7	Line reactors .....	48
3.7.1	Description .....	48
3.7.2	Safety information .....	49
3.7.3	Connection description .....	50
3.7.3.1	Overview .....	50
3.7.3.2	Line/load connection .....	51
3.7.4	Dimension drawings.....	52
3.7.5	Technical data.....	53
3.8	Line connection versions .....	55
3.8.1	Ways of connecting the line supply .....	55
3.8.2	Operating line connection components on the line supply .....	56
3.8.3	Operation of the line connection components via a transformer .....	57

3.8.3.1	Safety information .....	57
3.8.3.2	Line connection conditions.....	57
3.8.3.3	Dimensioning an isolating transformer/autotransformer for several loads .....	58
3.8.3.4	Operating line connection components via an autotransformer .....	62
3.8.3.5	Operating line connection components via an isolating transformer .....	64
<b>4</b>	<b>S120 Combi Power Modules .....</b>	<b>67</b>
4.1	Introduction .....	67
4.1.1	Description .....	67
4.1.2	Module versions .....	69
4.1.3	Approved controls .....	70
4.1.4	Expansion axes that can be connected .....	71
4.2	Safety information .....	72
4.3	Interface description.....	75
4.3.1	Overview diagrams .....	76
4.3.2	X1 line connection.....	80
4.3.3	X2-X5 motor connection .....	80
4.3.4	X11 brake connection .....	82
4.3.5	X12/X13 fan connection.....	83
4.3.6	X21/X22 EP terminals.....	84
4.3.7	X200-X205 DRIVE-CLiQ interfaces .....	86
4.3.8	X220 TTL encoder .....	88
4.3.9	X224 24 V connector .....	92
4.4	Connection examples .....	93
4.5	Meaning of the LEDs on the S120 Combi .....	96
4.6	Dimension drawings.....	97
4.7	Installation .....	99
4.7.1	Drilling patterns and installation cut-outs .....	99
4.7.2	Installing the reinforcement plates .....	101
4.7.2.1	Description .....	101
4.7.2.2	Installation .....	102
4.7.2.3	Technical data.....	105
4.7.3	Installing an S120 Combi Power Module.....	106
4.7.4	Assembling a drip protection grid.....	107
4.7.5	Mounting an external fan module.....	108
4.7.5.1	Description .....	108
4.7.5.2	Overview .....	108
4.7.5.3	Dimension drawing .....	110
4.7.5.4	Installation .....	111
4.7.5.5	Technical data.....	114
4.8	Electrical connection .....	114
4.8.1	Stripped length for the line supply and power cables .....	114
4.8.2	Line supply cable .....	116
4.8.3	Power cables for motors .....	117
4.8.4	Signal cables at the EP terminals .....	118
4.9	Technical data.....	119
4.9.1	Characteristic curves .....	123
4.9.1.1	Derating characteristics .....	130

<b>5</b>	<b>Topology rules for DRIVE-CLiQ.....</b>	<b>131</b>
5.1	Connection examples .....	134
5.1.1	Operation with a 3 axes Power Module .....	134
5.1.2	Operation with a 4 axes Power Module .....	136
<b>6</b>	<b>Motor Modules Booksize Compact as expansion axes .....</b>	<b>139</b>
6.1	Description .....	139
6.2	Safety information .....	140
6.3	Interface description.....	143
6.3.1	Overview .....	143
6.3.2	X1/X2 motor connection.....	145
6.3.3	X11/X12 motor brake connection .....	146
6.3.4	X21/X22 EP terminals / temperature sensor Motor Module .....	147
6.3.5	X200-X203 DRIVE-CLiQ interface.....	148
6.4	Connection example .....	149
6.5	Meaning of the LEDs on the Motor Module Booksize Compact.....	150
6.6	Dimension drawings.....	151
6.7	Installation.....	154
6.8	Technical data.....	155
6.8.1	Characteristics .....	157
<b>7</b>	<b>DC link components .....</b>	<b>161</b>
7.1	Control Supply Module CSM .....	161
7.1.1	Description .....	161
7.1.2	Safety information.....	162
7.1.3	Interface description.....	164
7.1.3.1	Overview .....	164
7.1.3.2	X1 line connection.....	165
7.1.3.3	X21 signaling contact.....	166
7.1.3.4	X24 24 V terminal adapter .....	166
7.1.3.5	S1 DIP switch.....	167
7.1.4	Connection example .....	168
7.1.5	Meaning of the LEDs on the Control Supply Module.....	170
7.1.6	Dimension drawing .....	171
7.1.7	Installation.....	172
7.1.8	Technical data.....	173
7.1.8.1	Characteristics .....	174
7.2	Braking Module Booksize .....	175
7.2.1	Description .....	175
7.2.2	Safety information .....	177
7.2.3	Interface description.....	179
7.2.3.1	Overview .....	179
7.2.3.2	X1 braking resistor connection .....	180
7.2.3.3	X21 digital inputs/outputs.....	181
7.2.4	Connection example .....	182
7.2.5	Meaning of the LEDs .....	183
7.2.6	Dimension drawing .....	184
7.2.7	Installation.....	185

7.2.8	Technical data.....	186
7.2.8.1	Characteristic curves .....	187
7.3	Braking resistors .....	188
7.3.1	Description .....	188
7.3.2	Safety information .....	189
7.3.3	Dimension drawings.....	190
7.3.4	Technical data.....	192
<b>8</b>	<b>Electrically connecting Motor Modules and DC link components.....</b>	<b>193</b>
8.1	Introduction .....	193
8.2	Removing the front cover and opening the DC link cover on the S120 Combi .....	193
8.3	Connection of DC link busbars and 24 V busbars .....	196
8.4	Connecting an additional component .....	199
<b>9</b>	<b>Additional system components.....</b>	<b>203</b>
9.1	Terminal Module TM54F.....	203
9.1.1	Description .....	203
9.1.2	Safety information .....	204
9.1.3	Interface description.....	205
9.1.3.1	Overview .....	205
9.1.3.2	X500/X501 DRIVE-CLiQ interfaces .....	206
9.1.3.3	X514 power supply for digital outputs and sensors .....	206
9.1.3.4	X520 sensor power supply.....	207
9.1.3.5	X521 fail-safe digital inputs + power supply with forced dormant error detection .....	207
9.1.3.6	X522 fail-safe digital inputs .....	208
9.1.3.7	X523 fail-safe digital output.....	209
9.1.3.8	X524 Electronics power supply.....	210
9.1.3.9	X525 fail-safe digital output.....	211
9.1.3.10	X531 fail-safe digital inputs + power supply with forced dormant error detection .....	212
9.1.3.11	X532 fail-safe digital inputs .....	213
9.1.3.12	X533 fail-safe digital output.....	214
9.1.3.13	X535 fail-safe digital output.....	215
9.1.4	Connection example .....	216
9.1.5	Meaning of LEDs.....	217
9.1.6	Dimension drawing .....	219
9.1.7	Installation .....	220
9.1.8	Protective conductor connection and shield support .....	221
9.1.9	Technical data.....	222
9.2	DRIVE-CLiQ Hub Module DMC20 .....	222
9.2.1	Description .....	222
9.2.2	Safety information .....	223
9.2.3	Interface description.....	224
9.2.3.1	Overview .....	224
9.2.3.2	X524 Electronics power supply.....	225
9.2.3.3	X500-X505 DRIVE-CLiQ interfaces.....	225
9.2.3.4	Meaning of the LED on the DMC20 .....	226
9.2.4	Dimension drawing .....	227
9.2.5	Installation .....	228
9.2.6	Technical data.....	229



9.3	DRIVE-CLiQ Hub Module External DME20 .....	229
9.3.1	Description .....	229
9.3.2	Safety information .....	230
9.3.3	Interface description .....	231
9.3.3.1	Overview .....	231
9.3.3.2	X500-X505 DRIVE-CLiQ interfaces .....	232
9.3.3.3	X524 Electronics power supply .....	232
9.3.4	Dimension drawing .....	234
9.3.5	Installation .....	235
9.3.6	Technical data .....	235
9.3.7	Specifications for use with UL approval .....	236
<b>10</b>	<b>Encoder system connection .....</b>	<b>237</b>
10.1	Sensor Module Cabinet-Mounted SMC20 .....	237
10.1.1	Description .....	237
10.1.2	Product-specific safety instructions .....	237
10.1.3	Interface description .....	239
10.1.3.1	Overview .....	239
10.1.3.2	X500 DRIVE-CLiQ interface .....	240
10.1.3.3	X520 encoder system interface .....	241
10.1.3.4	X524 Electronics power supply .....	242
10.1.3.5	Meaning of the LED on the Sensor Module Cabinet-Mounted SMC20 .....	243
10.1.4	Dimension drawing .....	244
10.1.5	Mounting .....	244
10.1.6	Technical data .....	246
10.2	Sensor Module Cabinet-Mounted SMC30 .....	247
10.2.1	Description .....	247
10.2.2	Interface description .....	248
10.2.2.1	Overview .....	248
10.2.2.2	X500 DRIVE-CLiQ interface .....	249
10.2.2.3	X520 encoder system interface .....	249
10.2.2.4	X521 / X531 alternative encoder system interface .....	251
10.2.2.5	X524 Electronics power supply .....	253
10.2.3	Meaning of the LEDs .....	254
10.2.3.1	Meaning of LEDs on the Sensor Module Cabinet-Mounted SMC30 .....	254
10.2.3.2	Cause and rectification of faults .....	255
10.2.4	Dimension drawing .....	255
10.2.5	Mounting .....	256
10.2.6	Protective conductor connection and shield support .....	257
10.2.7	Technical data .....	258
10.3	Sensor Module External SME20 .....	263
10.3.1	Description .....	263
10.3.2	Safety Information .....	263
10.3.3	Interface description .....	264
10.3.3.1	Overview .....	264
10.3.3.2	Connection example .....	264
10.3.3.3	DRIVE-CLiQ interface .....	265
10.3.3.4	Encoder system interface .....	266
10.3.4	Dimension drawing .....	267
10.3.5	Installation .....	268
10.3.6	Technical data .....	269

10.4	Sensor Module External SME25.....	271
10.4.1	Description .....	271
10.4.2	Interface description.....	271
10.4.2.1	Overview .....	271
10.4.2.2	Connection example .....	272
10.4.2.3	DRIVE-CLiQ interface.....	272
10.4.2.4	Encoder system interface .....	273
10.4.3	Dimension drawing .....	274
10.4.4	Installation.....	275
10.4.5	Technical data.....	276
<b>11</b>	<b>Accessories .....</b>	<b>279</b>
11.1	DRIVE-CLiQ cabinet bushing .....	279
11.1.1	Description .....	279
11.1.2	Interface description.....	280
11.1.2.1	Overview .....	280
11.1.3	Dimension drawings.....	281
11.1.4	DRIVE-CLiQ cabinet bushing for cables with DRIVE-CLiQ connectors .....	282
11.1.5	Technical data.....	284
11.2	DRIVE-CLiQ coupling .....	284
11.2.1	Description .....	284
11.2.2	Safety information .....	284
11.2.3	Interface description.....	285
11.2.3.1	Overview .....	285
11.2.4	Dimension drawing .....	285
11.2.5	Mounting .....	286
11.2.6	Technical data.....	286
<b>12</b>	<b>Cabinet design and EMC .....</b>	<b>287</b>
12.1	General information .....	287
12.2	Safety information .....	288
12.3	Directives .....	289
12.4	Notes on electromagnetic compatibility (EMC).....	289
12.5	Cable shielding and routing .....	291
12.6	24 V DC supply .....	293
12.6.1	General information .....	293
12.6.2	24 V power supply and connection of components .....	295
12.6.3	Overcurrent protection in the 24 V solid-state circuit.....	297
12.6.4	Typical 24 V current consumption of the components.....	298
12.6.5	Selecting power supply units .....	300
12.7	Connection system .....	301
12.7.1	DRIVE-CLiQ signal cables.....	301
12.7.2	Power cables for motors .....	302
12.7.2.1	Approved power cables .....	302
12.7.3	Current-carrying capacity and derating factors for power cables and signal cables .....	305
12.7.4	Connectable conductor cross-sections for spring-loaded terminals.....	306
12.7.5	Connectable conductor cross-sections for screw terminals .....	307
12.7.6	Cable lugs .....	308

12.8	Protective connection and equipotential bonding .....	308
12.9	Note on control cabinet cooling .....	310
12.9.1	General information .....	310
12.9.2	Ventilation .....	313
12.9.3	Dimensioning Climate Control Equipment .....	315
12.9.4	Power loss of components in rated operation .....	316
12.9.4.1	General information .....	316
12.9.4.2	Power losses for SINUMERIK control systems, DC link components and supplementary system components .....	316
12.9.4.3	Power losses for S120 Combi Power Modules .....	317
12.9.4.4	Power loss for line filters and line reactors .....	317
12.9.4.5	Electronics losses of power units.....	318
12.9.4.6	Losses in partial-load operation .....	319
<b>13</b>	<b>Service and maintenance.....</b>	<b>321</b>
13.1	Spare parts .....	321
13.2	Replacing the fan .....	322
13.2.1	Safety instructions when replacing a fan .....	322
13.2.2	Replacing the Internal fan on the S120 Combi Power Module.....	322
13.2.3	Replacing the fan on the Motor Modules Booksize Compact.....	325
13.2.4	Replacing the fan on the Control Supply Module .....	328
13.3	Cleaning the S120 Combi heat sink .....	331
13.4	Forming the DC link capacitors.....	334
13.5	Recycling and disposal .....	335
<b>A</b>	<b>Appendix.....</b>	<b>337</b>
A.1	List of abbreviations .....	337
A.2	Documentation overview .....	347
	<b>Index.....</b>	<b>349</b>



# Fundamental safety instructions

## 1.1 General safety instructions



### DANGER

#### Danger to life due to live parts and other energy sources

Death or serious injury can result when live parts are touched.

- Only work on electrical devices when you are qualified for this job.
- Always observe the country-specific safety rules.

Generally, six steps apply when establishing safety:

1. Prepare for shutdown and notify all those who will be affected by the procedure.
2. Disconnect the machine from the supply.
  - Switch off the machine.
  - Wait until the discharge time specified on the warning labels has elapsed.
  - Check that it really is in a no-voltage condition, from phase conductor to phase conductor and phase conductor to protective conductor.
  - Check whether the existing auxiliary supply circuits are de-energized.
  - Ensure that the motors cannot move.
3. Identify all other dangerous energy sources, e.g. compressed air, hydraulic systems, or water.
4. Isolate or neutralize all hazardous energy sources by closing switches, grounding or short-circuiting or closing valves, for example.
5. Secure the energy sources against switching on again.
6. Ensure that the correct machine is completely interlocked.

After you have completed the work, restore the operational readiness in the inverse sequence.



### WARNING

#### Danger to life through a hazardous voltage when connecting an unsuitable power supply

Touching live components can result in death or severe injury.

- Only use power supplies that provide SELV (Safety Extra Low Voltage) or PELV- (Protective Extra Low Voltage) output voltages for all connections and terminals of the electronics modules.



**! WARNING**

**Danger to life when live parts are touched on damaged devices**

Improper handling of devices can cause damage.

For damaged devices, hazardous voltages can be present at the enclosure or at exposed components; if touched, this can result in death or severe injury.

- Ensure compliance with the limit values specified in the technical data during transport, storage and operation.
- Do not use any damaged devices.



**! WARNING**

**Danger to life through electric shock due to unconnected cable shields**

Hazardous touch voltages can occur through capacitive cross-coupling due to unconnected cable shields.

- As a minimum, connect cable shields and the conductors of power cables that are not used (e.g. brake cores) at one end at the grounded housing potential.



**! WARNING**

**Danger to life due to electric shock when not grounded**

For missing or incorrectly implemented protective conductor connection for devices with protection class I, high voltages can be present at open, exposed parts, which when touched, can result in death or severe injury.

- Ground the device in compliance with the applicable regulations.



**! WARNING**

**Danger to life due to electric shock when opening plug connections in operation**

When opening plug connections in operation, arcs can result in severe injury or death.

- Only open plug connections when the equipment is in a no-voltage state, unless it has been explicitly stated that they can be opened in operation.

**NOTICE****Material damage due to loose power connections**

Insufficient tightening torques or vibrations can result in loose electrical connections. This can result in damage due to fire, device defects or malfunctions.

- Tighten all power connections with the specified tightening torques, e.g. line supply connection, motor connection, DC link connections.
- Check all power connections at regular intervals. This applies in particular after transport.

 **WARNING****Danger to life due to fire spreading if housing is inadequate**

Fire and smoke development can cause severe personal injury or material damage.

- Install devices without a protective housing in a metal control cabinet (or protect the device by another equivalent measure) in such a way that contact with fire is prevented.
- Ensure that smoke can only escape via controlled and monitored paths.

 **WARNING****Danger to life through unexpected movement of machines when using mobile wireless devices or mobile phones**

Using mobile wireless devices or mobile phones with a transmit power > 1 W closer than approx. 2 m to the components may cause the devices to malfunction, influence the functional safety of machines therefore putting people at risk or causing material damage.

- Switch the wireless devices or mobile phones off in the immediate vicinity of the components.

 **WARNING****Danger to life due to the motor catching fire in the event of insulation overload**

There is higher stress on the motor insulation through a ground fault in an IT system. If the insulation fails, it is possible that death or severe injury can occur as a result of smoke and fire.

- Use a monitoring device that signals an insulation fault.
- Correct the fault as quickly as possible so the motor insulation is not overloaded.

 **WARNING**

**Danger to life due to fire if overheating occurs because of insufficient ventilation clearances**

Inadequate ventilation clearances can cause overheating of components with subsequent fire and smoke. This can cause severe injury or even death. This can also result in increased downtime and reduced service lives for devices/systems.

- Ensure compliance with the specified minimum clearance as ventilation clearance for the respective component.

 **WARNING**

**Danger of an accident occurring due to missing or illegible warning labels**

Missing or illegible warning labels can result in accidents involving death or serious injury.

- Check that the warning labels are complete based on the documentation.
- Attach any missing warning labels to the components, in the national language if necessary.
- Replace illegible warning labels.

**NOTICE**

**Device damage caused by incorrect voltage/insulation tests**

Incorrect voltage/insulation tests can damage the device.

- Before carrying out a voltage/insulation check of the system/machine, disconnect the devices as all converters and motors have been subject to a high voltage test by the manufacturer, and therefore it is not necessary to perform an additional test within the system/machine.

 **WARNING**

**Danger to life when safety functions are inactive**

Safety functions that are inactive or that have not been adjusted accordingly can cause operational faults on machines that could lead to serious injury or death.

- Observe the information in the appropriate product documentation before commissioning.
- Carry out a safety inspection for functions relevant to safety on the entire system, including all safety-related components.
- Ensure that the safety functions used in your drives and automation tasks are adjusted and activated through appropriate parameterizing.
- Perform a function test.
- Only put your plant into live operation once you have guaranteed that the functions relevant to safety are running correctly.



**Note****Important safety notices for Safety Integrated functions**

If you want to use Safety Integrated functions, you must observe the safety notices in the Safety Integrated manuals.

## 1.2 Safety instructions for electromagnetic fields (EMF)



 <b>WARNING</b>
--

**Danger to life from electromagnetic fields**

Electromagnetic fields (EMF) are generated by the operation of electrical power equipment such as transformers, converters or motors.

People with pacemakers or implants are at a special risk in the immediate vicinity of these devices/systems.

- Ensure that the persons involved are the necessary distance away (minimum 2 m).

## 1.3 Handling electrostatic sensitive devices (ESD)

Electrostatic sensitive devices (ESD) are individual components, integrated circuits, modules or devices that may be damaged by either electric fields or electrostatic discharge.



<b>NOTICE</b>
---------------

**Damage through electric fields or electrostatic discharge**

Electric fields or electrostatic discharge can cause malfunctions through damaged individual components, integrated circuits, modules or devices.

- Only pack, store, transport and send electronic components, modules or devices in their original packaging or in other suitable materials, e.g. conductive foam rubber or aluminum foil.
- Only touch components, modules and devices when you are grounded by one of the following methods:
  - Wearing an ESD wrist strap
  - Wearing ESD shoes or ESD grounding straps in ESD areas with conductive flooring
- Only place electronic components, modules or devices on conductive surfaces (table with ESD surface, conductive ESD foam, ESD packaging, ESD transport container).

## 1.4 Industrial security

### Note

#### Industrial security

Siemens provides products and solutions with industrial security functions that support the secure operation of plants, solutions, machines, equipment and/or networks. They are important components in a holistic industrial security concept. With this in mind, Siemens' products and solutions undergo continuous development. Siemens recommends strongly that you regularly check for product updates.

For the secure operation of Siemens products and solutions, it is necessary to take suitable preventive action (e.g. cell protection concept) and integrate each component into a holistic, state-of-the-art industrial security concept. Third-party products that may be in use should also be considered. For more information about industrial security, visit this address (<http://www.siemens.com/industrialsecurity>).

To stay informed about product updates as they occur, sign up for a product-specific newsletter. For more information, visit this address (<http://support.automation.siemens.com>).

### WARNING

#### **Danger as a result of unsafe operating states resulting from software manipulation**

Software manipulation (e.g. by viruses, Trojan horses, malware, worms) can cause unsafe operating states to develop in your installation which can result in death, severe injuries and/or material damage.

- Keep the software up to date.  
You will find relevant information and newsletters at this address (<http://support.automation.siemens.com>).
- Incorporate the automation and drive components into a holistic, state-of-the-art industrial security concept for the installation or machine.  
You will find further information at this address (<http://www.siemens.com/industrialsecurity>).
- Make sure that you include all installed products into the holistic industrial security concept.

### WARNING

#### **Danger to life due to software manipulation when using exchangeable storage media**

Storing files onto exchangeable storage media amounts to an increased risk of infection, e.g. with viruses and malware. As a result of incorrect parameterization, machines can malfunction, which in turn can lead to injuries or death.

- Protect files stored on exchangeable storage media from malicious software by taking suitable protection measures, e.g. virus scanners.

## 1.5 Residual risks of power drive systems

When assessing the machine- or system-related risk in accordance with the respective local regulations (e.g., EC Machinery Directive), the machine manufacturer or system installer must take into account the following residual risks emanating from the control and drive components of a drive system:

1. Unintentional movements of driven machine or system components during commissioning, operation, maintenance, and repairs caused by, for example,
  - Hardware and/or software errors in the sensors, control system, actuators, and cables and connections
  - Response times of the control system and of the drive
  - Operation and/or environmental conditions outside the specification
  - Condensation/conductive contamination
  - Parameterization, programming, cabling, and installation errors
  - Use of wireless devices/mobile phones in the immediate vicinity of electronic components
  - External influences/damage
  - X-ray, ionizing radiation and cosmic radiation
2. Unusually high temperatures, including open flames, as well as emissions of light, noise, particles, gases, etc., can occur inside and outside the components under fault conditions caused by, for example:
  - Component failure
  - Software errors
  - Operation and/or environmental conditions outside the specification
  - External influences/damage
3. Hazardous shock voltages caused by, for example:
  - Component failure
  - Influence during electrostatic charging
  - Induction of voltages in moving motors
  - Operation and/or environmental conditions outside the specification
  - Condensation/conductive contamination
  - External influences/damage
4. Electrical, magnetic and electromagnetic fields generated in operation that can pose a risk to people with a pacemaker, implants or metal replacement joints, etc., if they are too close
5. Release of environmental pollutants or emissions as a result of improper operation of the system and/or failure to dispose of components safely and correctly

For more information about the residual risks of the drive system components, see the relevant sections in the technical user documentation.



# System overview

## 2.1 SINAMICS S120 Combi components

### System components

- Line-side power components such as fuses and contactors to switch the energy supply
- Reactors and filters to maintain EMC regulations
- Motor Modules for 1 - 2 expansion axes which function as inverters and provide the energy to the connected motors
- DC link components (Braking Module, Control Supply Module) used optionally for stabilizing the DC link voltage
- Additional system components and encoder system connections to expand the functionality and to handle various interfaces for encoders and process signals.

The SINAMICS S120 Combi is intended for installation in a control cabinet. It sets itself apart as a result of the following properties:

- Easy to handle, simple installation and wiring
- Practical connection system, cable routing in accordance with EMC requirements
- Standardized design, side-by-side mounting

### Application and cooling method

The S120 Combi Power Modules are optimized as a drive for processing machines with 3 to 6 axes. The Power Modules are available with the "external air cooling" cooling method.

Motor Modules in the booksize compact format are used as expansion axes.

2.1 SINAMICS S120 Combi components

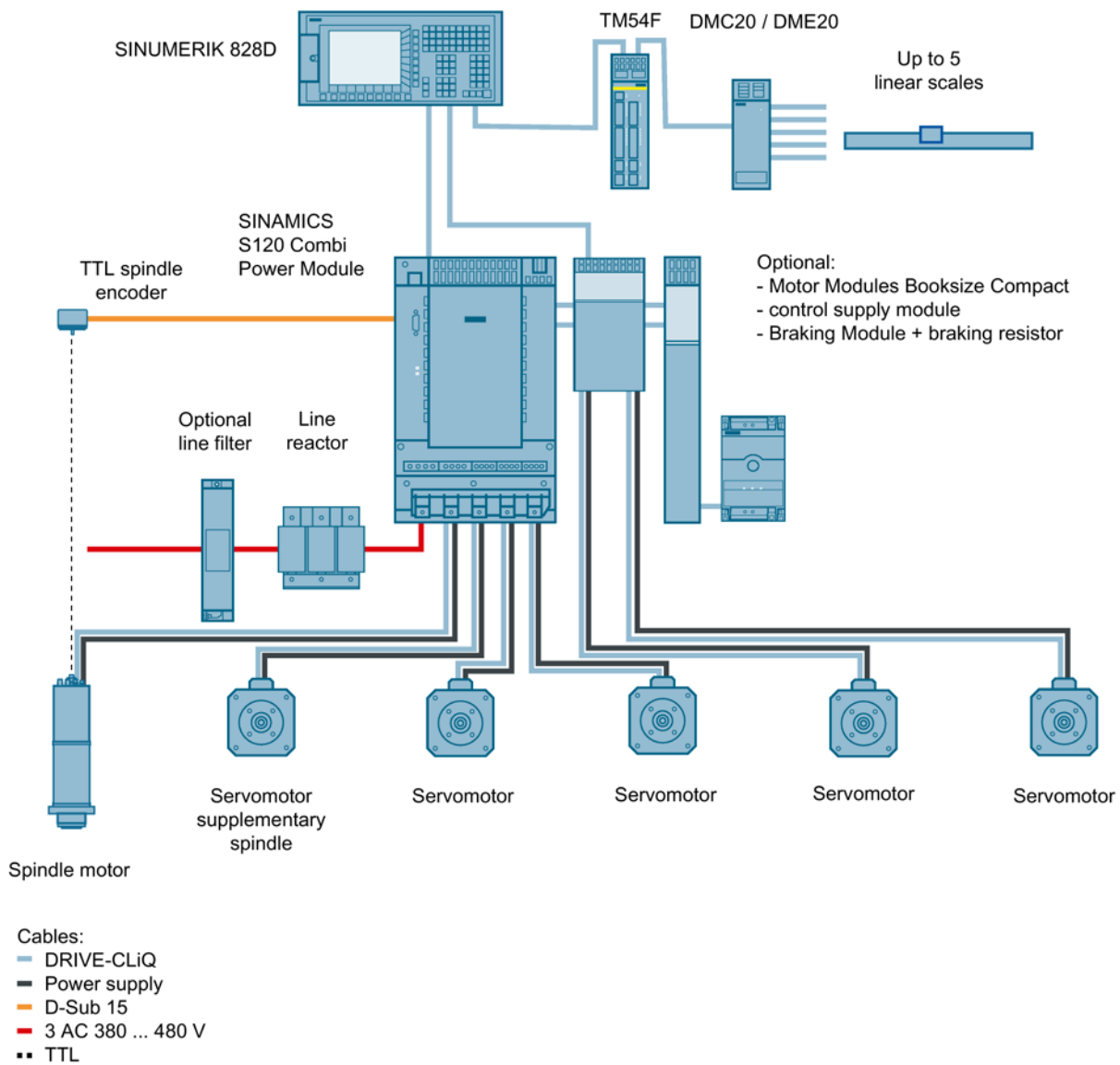

Figure 2-1 Connection example, S120 Combi 4-axis Power Module with 2 expansion axes connected to SINUMERIK 828D (maximum expansion stage)

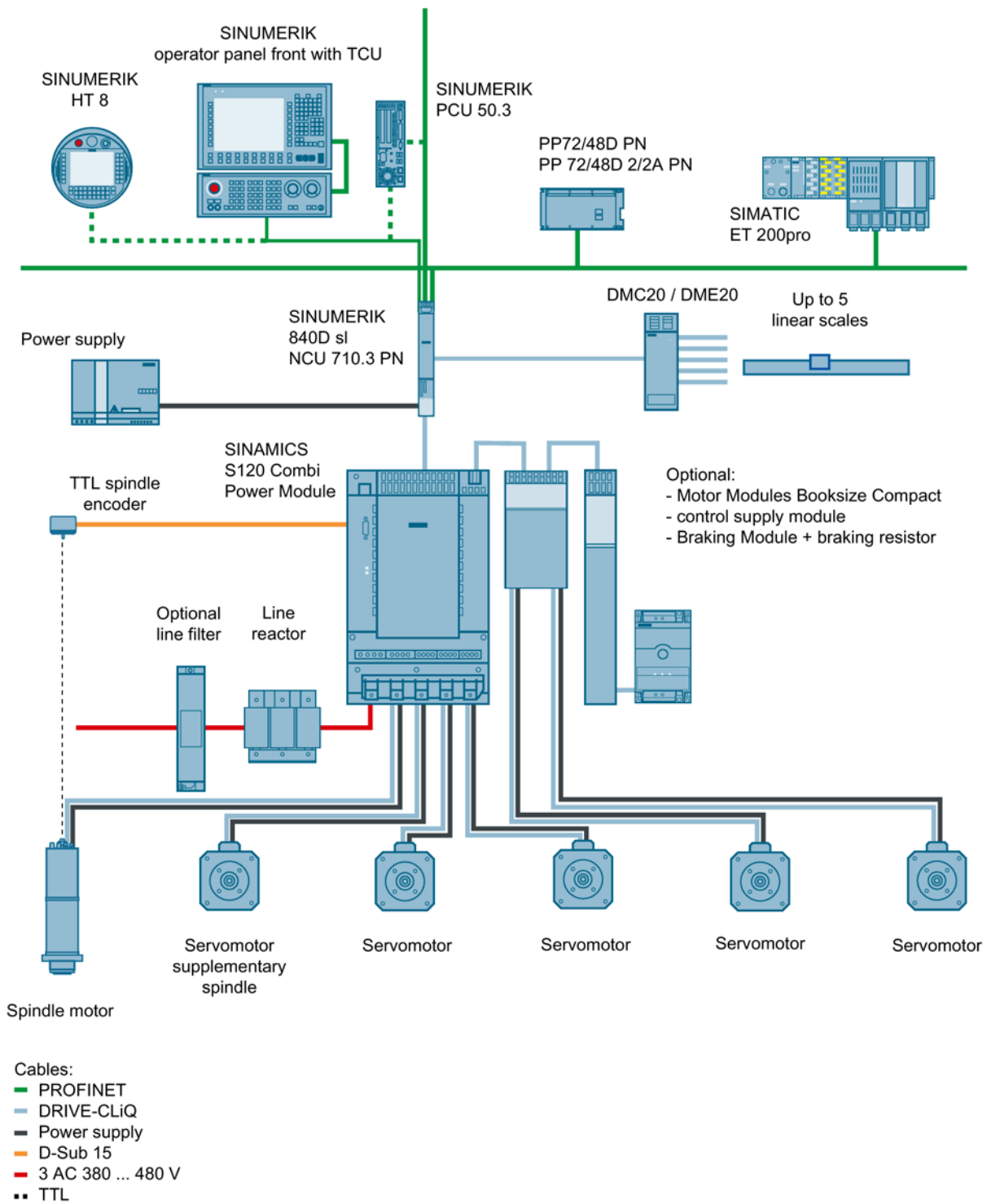

Figure 2-2 Connection example, S120 Combi 4-axis Power Module with 2 expansion axes connected to SINUMERIK 840D sl (maximum expansion stage)

## 2.2 System data

### Technical data

The following technical data apply for SINAMICS S120 Combi Power Modules.

Table 2- 1 Electrical data

Line connection voltage	3 AC 380 V - 10 % ... 3 AC 480 V + 10 % Above an installation altitude of 2000 m, an isolating transformer must be used (see Chapter Derating as a function of the installation altitude and ambient temperature (Page 34)).
Line frequency	45 Hz ... 66 Hz
Line supply types	TN, TT, and IT line supplies
Electronics power supply	24 V DC 15/20 % <sup>1)</sup> , Safety extra-low voltage PELV or SELV (see Chapter 24 V DC supply (Page 293))
Rated short-circuit current SCCR according to UL508C	65 kA
Radio interference suppression	Category C2 acc. to EN 61800-3 for system versions in conformance with the documentation
Overvoltage category	III to EN 61800-5-1
Pollution degree	2 acc. to EN 61800-5

<sup>1)</sup> If a motor holding brake is used, restricted voltage tolerances (24 V ± 10 %) may have to be taken into account.

Table 2- 2 Environmental conditions

Degree of protection	IPXXB acc. to EN 60529, open type according to UL508
Protection class, line supply circuits Electronic circuits	I (with protective conductor connection) safety extra-low voltage PELV / SELV
Permissible cooling medium temperature (air) and installation altitude in operation	0°C to +45°C up to an installation altitude of 1000 m without derating, installation altitude >1000 m up to 4000 m, see the derating characteristic (Page 130) with respect to the installation altitude or reduction of the ambient temperature by 3.5 K per 500 m.
<b>Chemically active substances</b>	
Long-term storage in the transport packaging	Class 1C2 according to EN 60721-3-1
Transport in the transport packaging	Class 2C2 according to EN 60721-3-2
Operation	Class 3C2 according to EN 60721-3-3
<b>Biological environmental conditions</b>	
Long-term storage in the transport packaging	Class 1B1 according to EN 60721-3-1
Transport in the transport packaging	Class 2B1 according to EN 60721-3-2
Operation	Class 3B1 according to EN 60721-3-3
<b>Vibratory load</b>	
Long-term storage in the transport packaging	Class 1M2 according to EN 60721-3-1
Transport in the transport packaging	Class 2M3 according to EN 60721-3-2



<b>Shock load</b>	
Long-term storage in the transport packaging	Class 1M2 according to EN 60721-3-1
Transport in the transport packaging	Class 2M3 according to EN 60721-3-2
Operation	Test values: 15 g / 11 ms
<b>Climatic environmental conditions</b>	
Long-term storage in the transport packaging	Class 1K4 according to EN 60721-3-1 Temperature: -25°C ... +55°C
Transport in the transport packaging	Class 2K4 according to EN 60721-3-2 Temperature: -40°C ... +70°C
Operation	better than Class 3K3 according to EN 60721-3-3 Temperature: 0 °C ... +40 °C Relative humidity: 5 % ... 95 % (no condensation) Oil mist, salt mist, ice formation, condensation, dripping water, spraying water, splashing water and water jets are not permitted

Table 2- 3 Certificates

Declarations of Conformity	CE
Approvals	cURus

## 2.3 Derating as a function of the installation altitude and ambient temperature

The S120 Combi Power Modules and Motor Modules Booksize Compact are designed for operation at an ambient temperature of 40 °C, installation altitudes up to 1000 m above sea level and the relevant specified pulse frequency.

The air pressure and therefore air density drop at altitudes above sea level. At these altitudes, the same quantity of air does not have the same cooling effect and the air gap between two electrical conductors can only insulate a lower voltage. Typical values for air pressure are summarized in the table below:

Table 2- 4 Air pressure for various installation altitudes

Installation altitude above sea level in [m]	0	2000	3000	4000	5000
Air pressure in mbar [kPa]	100	80	70	62	54

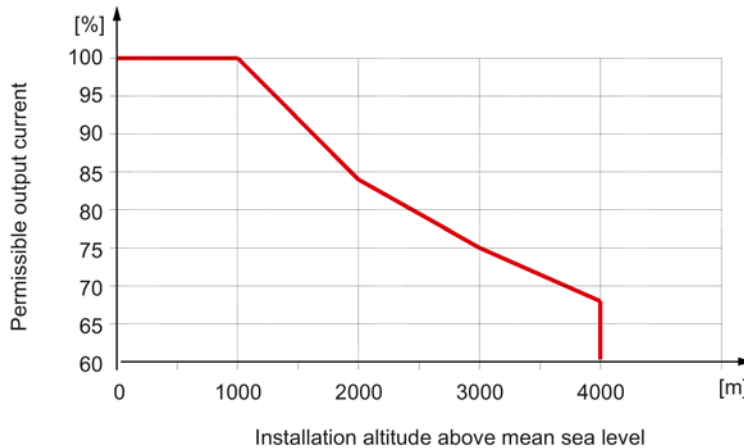

Figure 2-3 Output current as a function of the installation altitude

The output current must be reduced if the modules are operated at ambient temperatures above 40 °C. Ambient temperatures above 55 °C are not permissible.

At installation altitudes above 2000 m, the Power Modules must be connected using an isolating transformer. The secondary line supply system must be implemented as follows:

- TN line supply with grounded star point (no grounded outer conductor)
- IT line supply

A reduction of the line supply voltage phase-phase is not necessary.

## 2.3 Derating as a function of the installation altitude and ambient temperature

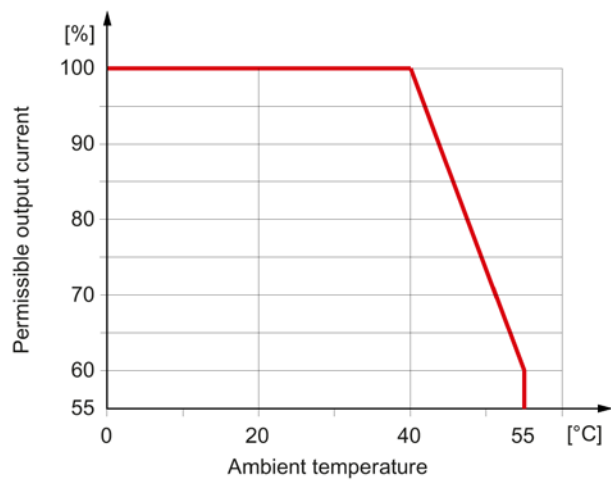

Figure 2-4 Output current as a function of the temperature



# Line-side power components

## 3.1 Introduction

The following components should be used to connect the S120 Combi drive line-up to the line supply:

- Line disconnector
- Overcurrent protection device (line fuse or circuit breaker)
- Line contactor (this is required for electrical isolation)
- Line filter
- Line reactor (always required)

The line connection for a SINAMICS S120 Combi comprises in addition to the regionally required protective devices, an optional line filter and a line reactor:

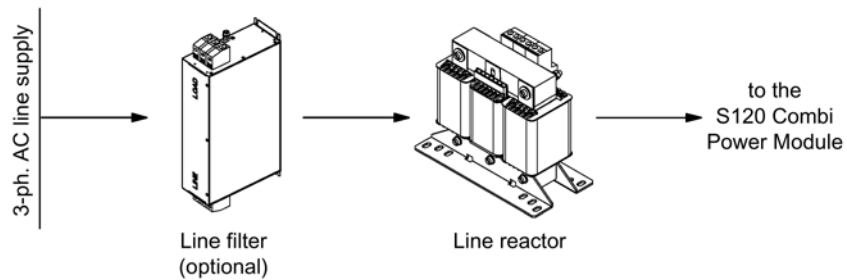

Figure 3-1 Overview diagram, line connection

### 3.2 Information on the disconnecter unit

A line disconnecter is required to correctly disconnect the drive line-up from the line supply. The line disconnecter of the machine's electrical equipment can be used for this purpose. The line disconnecter must be selected in compliance with the requirements of the internationally binding standard relating to the electrical equipment of machines EN 60204-1, Section 5.3. The relevant technical data and any other loads connected to the electrical equipment must be taken into account when making your selection.

**NOTICE**

**Damage to loads connected in parallel caused by switching the line disconnecter while under load**

When switching the line disconnecter under load, the voltage applied can damage external loads located parallel to the drive on the same switching component.

- Firstly, interrupt the voltage at the X21 interface, terminal 3 (EP +24 V) and 4 (EP M) on the S120 Combi. This can be achieved with a leading disconnecting auxiliary contact ( $\geq 10$  ms), for example.

The accessories required for the line disconnecter must be selected from the manufacturer catalogs. See also catalog NC61.

### 3.3 Overcurrent protection by means of line fuses and circuit breakers

Line fuses or circuit breakers must be used for cable protection/overcurrent protection. NH, D, and DO type fuses with a gL characteristic or suitable circuit breakers according to IEC 60947 can be used for this purpose.

Table 3- 1 Recommended line fuses and circuit breakers for S120 Combi Power Modules

	10 kW	16 kW	20 kW
I <sub>n</sub> fuse	35 A	35 A	63 A
LV HRC line fuse	3NA3814	3NA3814	3NA3822
Circuit breaker (IEC 60947)	3RV1031-4FA10	3RV1031-4FA10	3RV1041-4JA10
<b>UL-application</b>			
Rated current	35 A	35 A	60 A
Line fuse <sup>1)</sup>	AJT 35	AJT 35	AJT 60
Circuit breaker	3VL2105-2KN30	3VL2105-2KN30	3VL2106-2KN30

<sup>1)</sup> Type AJT Class J, source: Ferraz Shawmut



**! WARNING**

**Danger to life through electric shock as well as fire hazard due to overcurrent protective devices that trip too late in TT line supplies when an insulation fault occurs**

Overcurrent protective devices that do not trip or trip too late can cause an electric shock or fire.

- Generally, due to the higher loop impedance of TT line supplies, the installed overcurrent protection devices are not tripped within the prescribed period if an insulation fault occurs.

When operating on TT line supplies, use a residual current protection device (see Chapter Line supply connection via residual-current devices (Page 40)) in addition to the overcurrent protective device.



**! WARNING**

**Danger to life through electric shock as well as fire hazard due to overcurrent protective devices that trip too late**

Overcurrent protective devices that do not trip or trip too late can cause an electric shock or fire.

- To protect personnel and for fire protection purposes, at the infeed point, the short-circuit rating and loop impedance must correspond to the specifications in the documentation in order for the installed overcurrent protection devices to trip within the specified time.



**! WARNING**

**Danger to life due to electric shock caused by oversized fuses**

Oversized fuses can result in significant levels of danger and also faults.

- Use an adapted fuse corresponding to the table "Recommended line fuses and circuit breakers for S120 Combi Power Modules".

## 3.4 Line supply connection via residual-current devices

Selectively tripping, AC/DC-sensitive residual current protection devices (type B) can be used in addition to the overcurrent protection devices.

### Residual-current operated circuit breakers (RCD)



#### **WARNING**

**Danger to life due to electric shock when a residual current protection device does not trip**

Overcurrent protective devices that do not trip or trip too late can cause an electric shock or fire.

- Check or activate the residual current circuit breaker in regular cycles.

The following points must be observed when using a residual current circuit breaker:

- It is only permissible to use a type B delayed tripping, selective AC/DC-sensitive residual current circuit breaker.
- The loop impedance must comply with local installation regulations.
- The maximum total length of the shielded power cables in the drive line-up (motor cables incl. line supply cables from the line filter to the connecting terminals of the S120 Combi) may be no more than 175 m.
- Only recommended line filters must be used in operation.
- Switching elements (disconnecter unit, contactors) for connecting and disconnecting the drive line-up have a maximum 35 ms delay time between closing/opening of the individual main contacts.



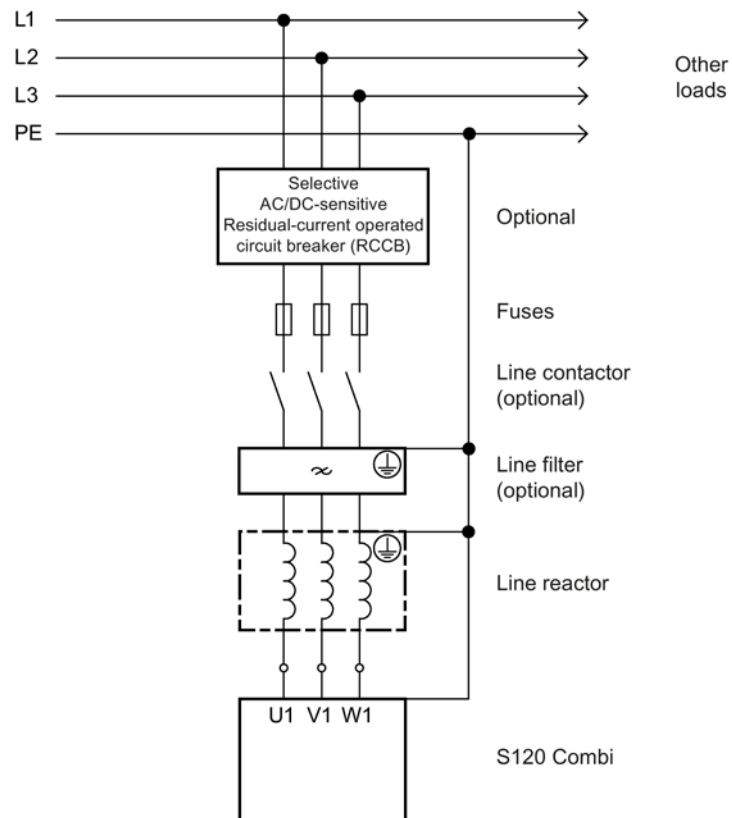

Figure 3-2 Connecting a residual-current operated circuit breaker

### Recommendation

SIEMENS selectively switching AC/DC-sensitive residual current protection devices in accordance with EN 61009-1 of the 5SM series e.g. 5SM3646-4 or 5SM3646-4+5SW3300 with an auxiliary disconnecter (1 NC contact / 1 NO contact) for a rated current of 63 A and rated residual current of 0.3 A (see catalog "BETA Modular Installation Devices - ET B1").

### Note

AC or pulse-sensitive RCCBs are not suitable.

### Derating characteristics

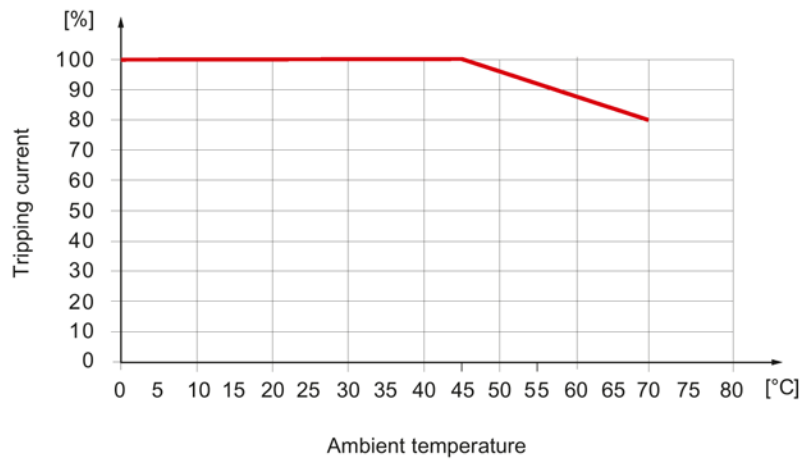

Figure 3-3 The rated current and tripping current depend on the ambient temperature for rated residual currents over 100 mA

## 3.5 Overvoltage protection

To protect the units against line-side surge voltages, install an overvoltage protection device (surge arrester) directly at the infeed point. For use in Canada, to comply with the requirements of CSA C22.2 No. 274, a UL category VZCA7 or VZCA8 surge arrester is absolutely mandatory. The Raycap company has suitable surge arresters.

## 3.6 Line filters

### 3.6.1 Description

Line filters have the task to attenuate conducted interference emission in the frequency range according to the specifications of EMC legislation. They are mainly effective in the frequency range from 150 kHz to 30 MHz; this is the range relevant to ensure compliance with the appropriate standard.

In conjunction with a line filter and the associated line reactor, drive line-ups with S120 Combi 10 kW, 16 kW and 20 kW Power Modules and a maximum total cable length up to 175 m, fulfill Category C2 according to EN 61800-3. An EMC compliant design is always assumed.

---

#### Note

The line filter is only suitable for direct connection to TN line supplies. An isolating transformer with vector group "Dyn" and grounded neutral point must be used when connecting to other line supplies. The line filter and the control cabinet must be connected to the isolating transformer neutral point through a low inductance connection.

---

### 3.6.2 Safety information

 <b>WARNING</b>
<b>Danger to life if the fundamental safety instructions and remaining risks are not carefully observed</b>
If the fundamental safety instructions and remaining risks in Chapter 1 (Page 21) are not observed, accidents involving severe injuries or death may occur.
<ul style="list-style-type: none"><li>• Adhere to the fundamental safety instructions.</li><li>• When assessing the risk, take into account residual risks.</li></ul>



 <b>DANGER</b>
<b>Danger to life through electric shock due to residual charge</b>
A hazardous voltage is still present for up to 5 minutes after the power supply has been switched off.
Contact with live parts can result in death or serious injury.
<ul style="list-style-type: none"><li>• Measure the voltage before starting any work.</li></ul>



 <b>WARNING</b>
<b>Danger to life through interruption of the external protective conductor due to high leakage currents</b>
The drive components conduct a high leakage current via the protective conductor. Touching conductive parts when the protective conductor is interrupted can result in death or serious injury.
<ul style="list-style-type: none"><li>• Ensure that the external protective conductor satisfies at least one of the following conditions:<ul style="list-style-type: none"><li>– It has been laid so that it is protected against mechanical damage.<sup>1)</sup></li><li>– If it is a single cable, it has a cross-section of at least 10 mm<sup>2</sup> Cu.</li><li>– If it is a conductor of a multi-conductor cable, it has a cross-section of at least 2.5 mm<sup>2</sup> Cu.</li><li>– It has a second protective conductor in parallel with the same cross-section.</li><li>– It complies with the local regulations for equipment with increased leakage current.</li></ul></li></ul>
<sup>1)</sup> Cables laid within control cabinets or closed machine housings are considered to be adequately protected against mechanical damage.

 <b>WARNING</b>
<b>Fire hazard due to overheating because of inadequate ventilation clearances</b>
Inadequate ventilation clearances can cause overheating with a risk for personnel through smoke development and fire. This can also result in more downtimes and Line Modules may have a reduced service life.
<ul style="list-style-type: none"><li>• It is absolutely essential that you maintain ventilation clearances according to the table Ventilation clearances above and below the component (Page 310).</li></ul>

**NOTICE****Damage to the line filter due to interchanging the input and output**

The line filter can be damaged if the input and output connections are interchanged.

- Connect the incoming line supply cable to LINE L1, L2, L3.
- Connect the outgoing cable to line reactor at LOAD L1', L2', L3'.

**NOTICE****Damage or fault to other loads when no line reactor is present**

If the SINAMICS line filter is directly connected to the S120 Combi and not connected via the associated line reactor, other loads can be damaged or destroyed.

- Connect the line filter to the S120 Combi via the associated line reactor.
- Connect additional loads upstream of the SINAMICS line filter (if required, via a separate line filter).

**NOTICE****Damage caused by third party filters**

According to product standard IEC 61800-3, RFI suppression commensurate with the relevant rated conditions is required. Line filters and line reactors are required for this purpose.

The use of filters of other makes can lead to limit value violations, resonances, overvoltages and irreparable damage to motors or other equipment.

- Only use line filters which are listed in this Manual.
- The machine manufacturer must provide verification that the machine equipped with the drive products and the installed suppression elements, e.g. line filters, is EMC-compliant before the machines are placed in the market.

**NOTICE****Damage caused by line filters which are not approved for the SINAMICS S120 Combi**

The integrated infeed can be damaged or destroyed when using line filters that have not been approved by SIEMENS for the SINAMICS S120 Combi Power Modules. Furthermore, line harmonics can occur that damage or destroy loads connected to the same line supply.

It is not permissible to connect other loads after the line filter.

- Only use line filters which have been approved for the SINAMICS S120 Combi.

**Note****System fault level at the infeed point**

In order to comply with EMC limit values, Category C2 according to EN 61800-3, the system fault level at the infeed point must be at least a factor 70 higher than the rated power of the integrated infeed.

**Note**

When a high-voltage test is conducted with alternating voltage in the system, the existing line filters must be disconnected in order to obtain accurate measurements.

**3.6.3 Interface description**

**3.6.3.1 Overview**

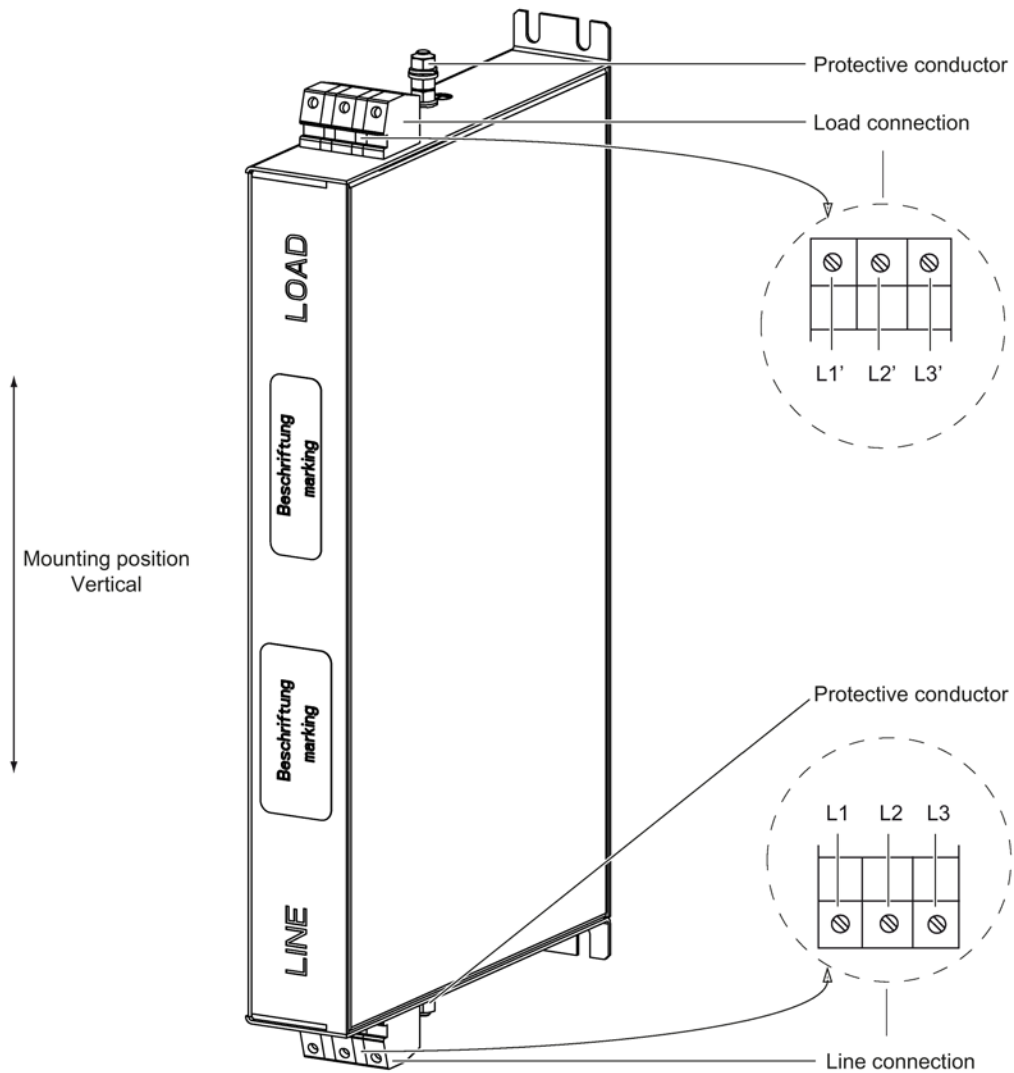

Figure 3-4 Line filter for S120 Combi

Either the upper or lower PE screw can be used for the connection. One of the screws remains unused. "Looping-through" the protective connection to the line reactor is not permissible.

### 3.6.3.2 Line/load connection

Table 3- 2 Line filter connection

<b>Article number</b>	<b>6SL3000-0BE21-6DA.</b>
Rated infeed power	10 kW, 16 kW and 20 kW
Line connection L1, L2, L3	Type: Screw terminal 6 (Page 307) Max. connectable cross-section: 10 mm <sup>2</sup> Tightening torque: 1.5 ... 1.8 Nm
Load connection L1', L2', L3' (U, V, W)	Type: Screw terminal 6 (Page 307) Max. connectable cross-section: 10 mm <sup>2</sup> Tightening torque: 1.5 ... 1.8 Nm
PE connection	Type: Grounding studs M6 tightening torque: 6 Nm

#### Note

The line filter 6SL3000-0BE21-6DAx can be used for all S120 Combi Power Modules.

### 3.6.4 Dimension drawing

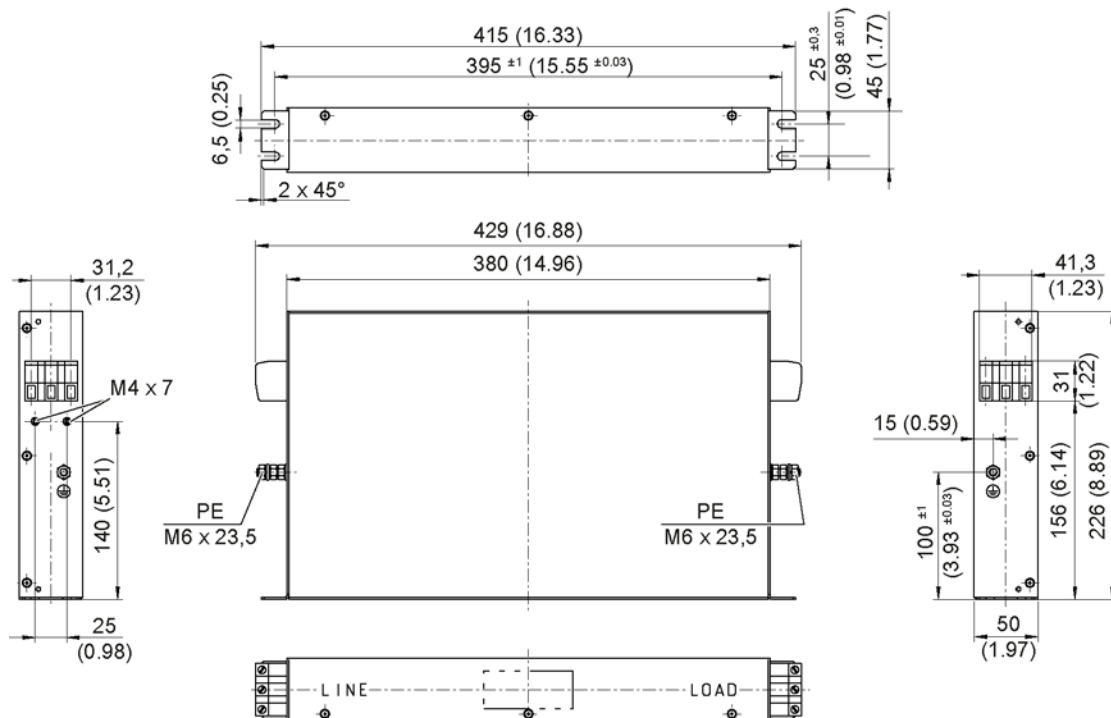

Figure 3-5 Dimension drawing of the line filter, all dimensions in mm and (inches)

### 3.6.5 Technical data

Table 3- 3 Technical data, line filter

6SL3000-0BE21-6DA0	Unit	
Rated power	kW	10, 16 and 20
Connection voltage: Line voltage Line frequency	V <sub>AC</sub> Hz	3 AC 380 - 10 % (- 15 % < 1 min) ... 3 AC 480 + 10 % 47 ... 63 Hz
Rated current	A <sub>AC</sub>	36
Power loss (see power loss tables (Page 316))	W	16 at 20 kW
Dimensions (W x H x D)	mm	50 x 420 x 226
Weight, approx.	kg	5
Degree of protection		IP20

## 3.7 Line reactors

### 3.7.1 Description

Line reactors for the S120 Combi limit low-frequency line harmonics to permissible values. For this reason, line reactors should always be used.



## 3.7.2 Safety information



### WARNING

**Danger to life if the fundamental safety instructions and remaining risks are not carefully observed**

If the fundamental safety instructions and remaining risks in Chapter 1 (Page 21) are not observed, accidents involving severe injuries or death may occur.

- Adhere to the fundamental safety instructions.
- When assessing the risk, take into account residual risks.

### DANGER

**Danger to life due to electric shock in the event of missing touch protection**

Death or serious injury can result when live parts are touched.

- For the reactor, use touch protection according to IPXXA or corresponding to the local installation regulations.

### NOTICE

**Damage caused by line reactors which are not approved for the SINAMICS S120 Combi**

The following can occur if line reactors are used that have not been approved for SINAMICS S120 Combi by SIEMENS:

- The infeed in the S120 Combi may be damaged or destroyed.
- Line harmonics may occur that damage or destroy loads connected to the same line supply.
- Only use line reactors which are listed in this Manual.

### NOTICE

**Damage due to high temperatures of line reactors**

The surface temperature of the line reactors may exceed 80°C. This can lead to temperature-related damage to adjacent components.

- It is absolutely essential that you maintain clearances according to the table Ventilation clearances above and below the component (Page 310) around the reactor.
- If this clearance cannot be observed, additional measures such as shielding plates or a cooling system must be provided.

### NOTICE

**Faults due to the magnetic fields of line reactors**

Reactors generate magnetic fields. Components and cables can be damaged or affected by this.

- Ensure there is sufficient clearance (at least 200 mm) from the reactors or shield them.

---

**Note**

**Connecting cables**

The connecting cables between the line reactor and S120 Combi must be kept as short as possible.

If at all possible, shielded connecting cables should be used.

When using unshielded connecting cables, the cores must be protected from rubbing against the shield connection clip.

---

**3.7.3 Connection description**

**3.7.3.1 Overview**

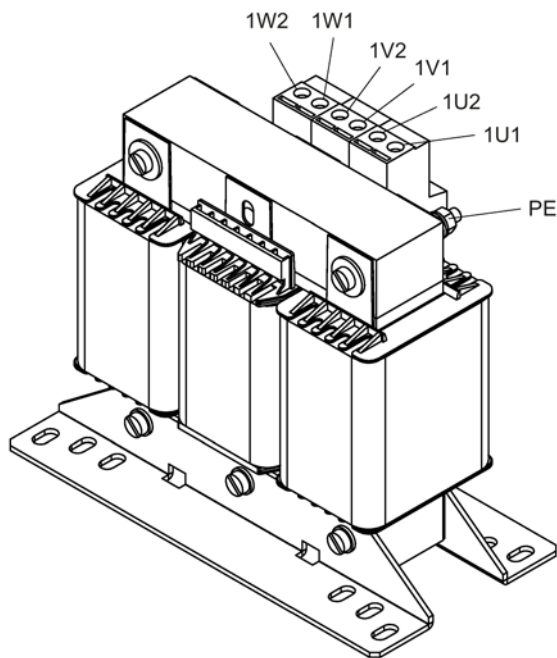

Figure 3-6 Line reactor for S120 Combi (example for 16 kW infeed)

### 3.7.3.2 Line/load connection

Table 3- 4 Connection of line reactors

Article number	6SL3100-0EE21-6AA0	6SL3100-0EE22-0AA0
Power [kW]	16	20
Line connection 1U1, 1V1, 1W1	Type: Screw terminal 7 (Page 307) Max. connectable cross-section: 16 mm <sup>2</sup> Tightening torque: 1.5 ... 1.8 Nm	Type: Screw terminal 7 (Page 307) Max. connectable cross-section: 16 mm <sup>2</sup> Tightening torque: 1.5 ... 1.8 Nm
Load connection 1U2, 1V2, 1W2	Type: Screw terminal 7 (Page 307) Max. connectable cross-section: 16 mm <sup>2</sup> Tightening torque: 1.5 ... 1.8 Nm	Type: Screw terminal 7 (Page 307) Max. connectable cross-section: 16 mm <sup>2</sup> Tightening torque: 1.5 ... 1.8 Nm
PE connection	Type: Grounding studs M6 tightening torque: 6 Nm	Grounding studs M6 tightening torque: 6 Nm

#### Note

A 6SL3111-4VE21-0EA0 Power Module (10 kW) must be combined with a 6SL3100-0EE21-6AA0 line reactor.

### 3.7.4 Dimension drawings

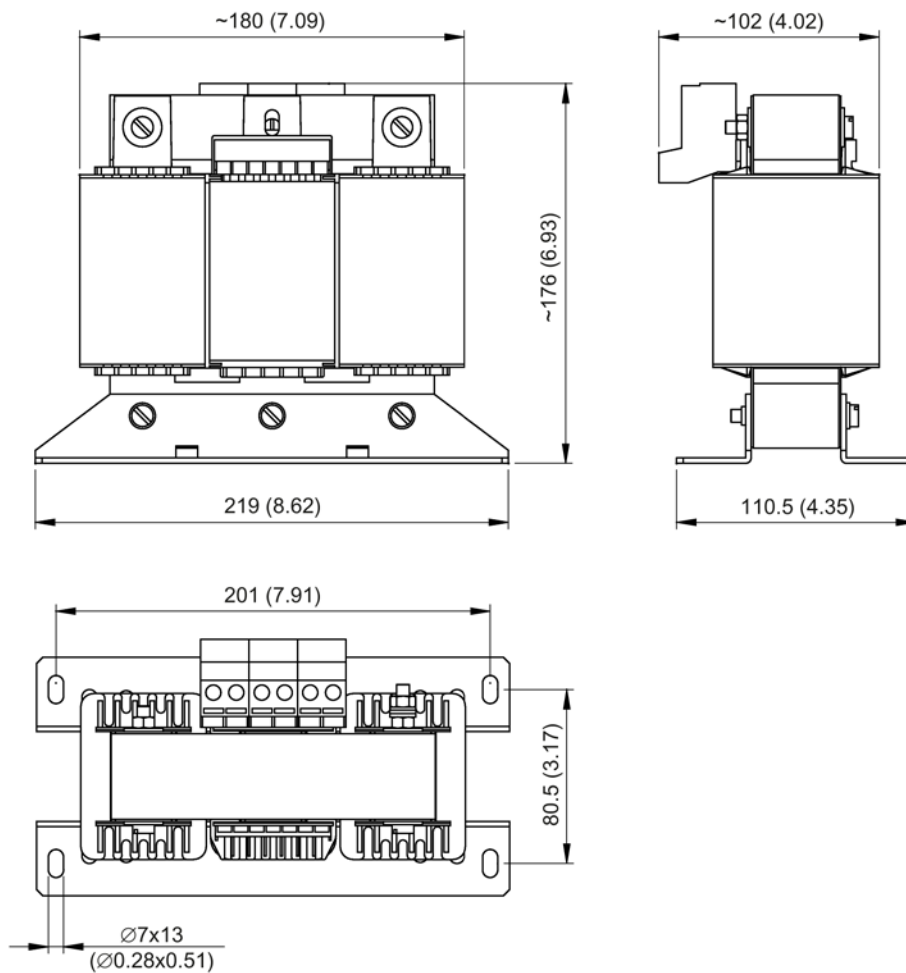

Figure 3-7 Dimension drawing of the line reactor for S120 Combi (16 kW infeed), all dimensions in mm and (inches)

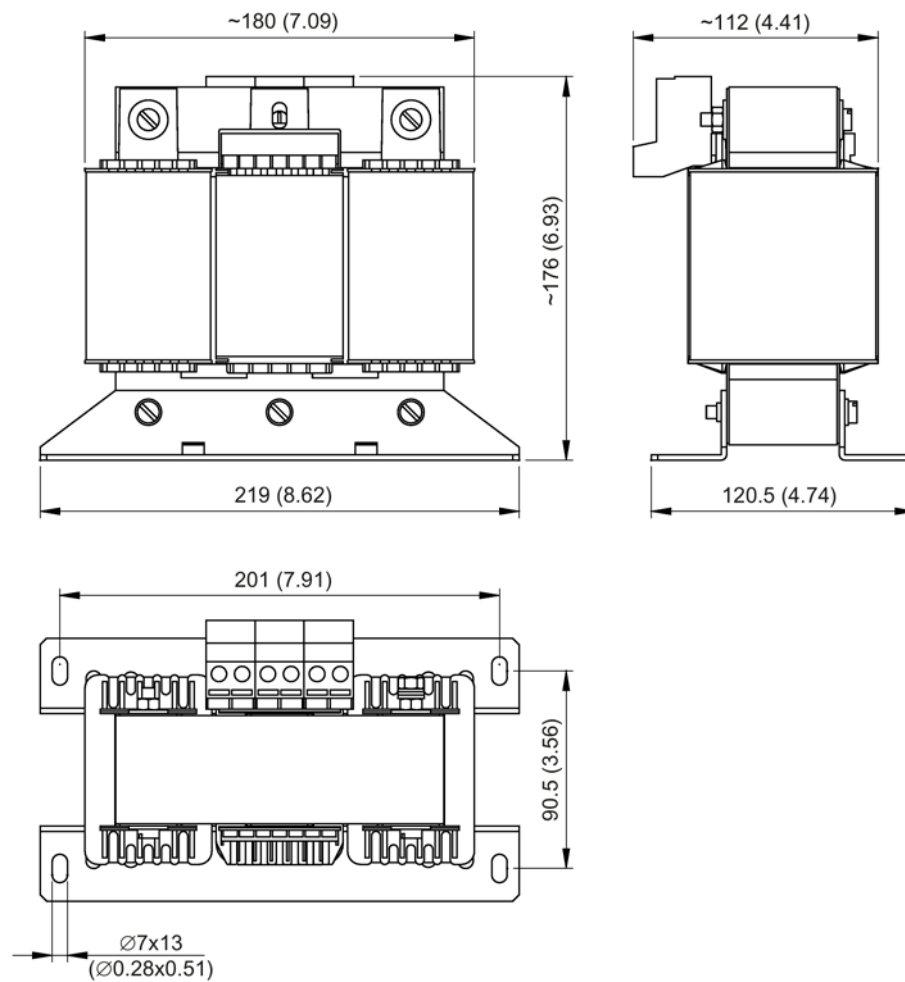

Figure 3-8 Dimension drawing of the line reactor for S120 Combi (20 kW infeed), all dimensions in mm and (inches)

### 3.7.5 Technical data

Table 3- 5 Technical data, line reactors for S120 Combi

	Unit	6SL3100-0EE21-6AA0	6SL3100-0EE22-0AA0
Rated power	kW	16	20
Rated current	$A_{rms}$	28	33
Power loss (see power loss tables (Page 316))	W	75	98
Dimensions (W x H x D)	mm	219 x 176 x 120	219 x 176 x 130
Weight	kg	10.7	10.9
Degree of protection		IPXXA	IPXXA



## 3.8 Line connection versions

### 3.8.1 Ways of connecting the line supply

The following line connection versions are possible:

- Line connection components to be directly connected to the line supply
- Operating line connection components via an autotransformer
- Operating line connection components via an isolating transformer

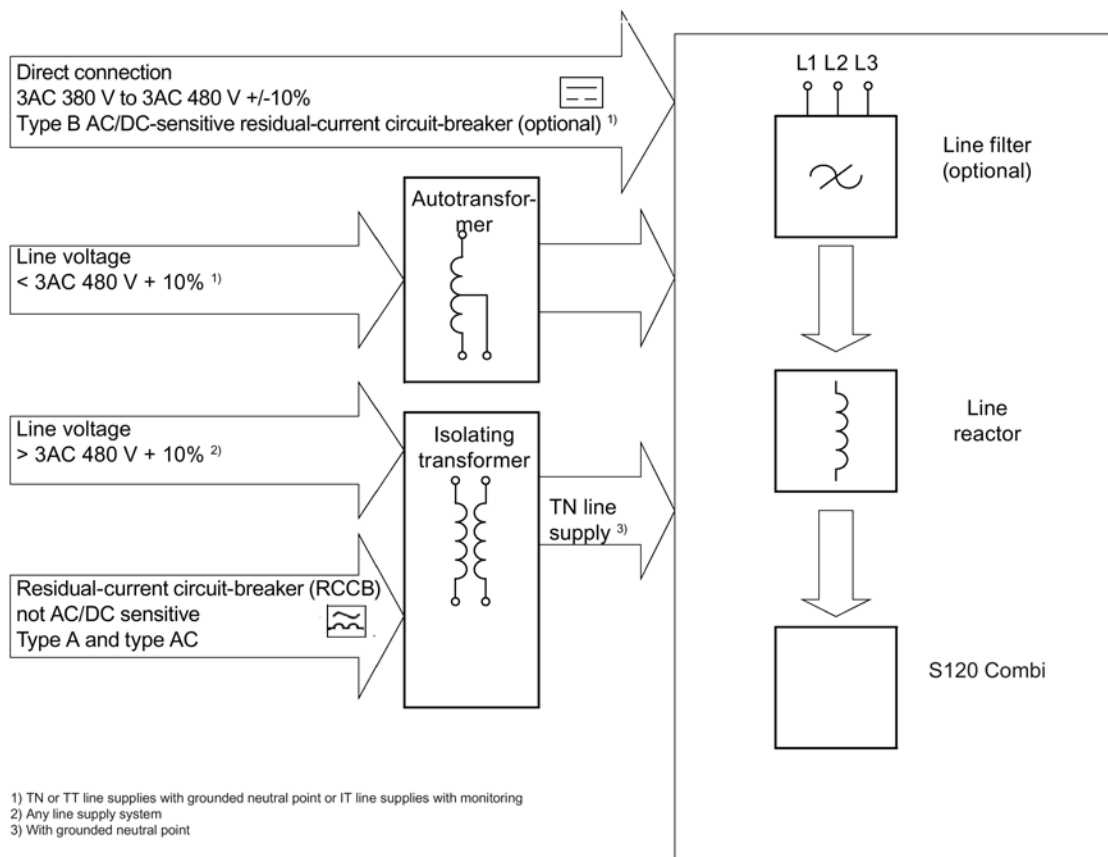

Figure 3-9 Overview of line connection versions

**Note**

**Line connection of motors**

In combination with the drive system, the motors are generally approved for operation on TN and TT line supplies with grounded neutral point and on IT line supplies.

In operation on IT line supplies, the occurrence of a first fault between an active part and ground must be signaled by a monitoring device. The first fault must be removed as quickly as possible to minimize temporary overload of the motor insulation.

For all other line supplies, except TN and TT line supplies with grounded neutral point and IT line supplies, such as line supplies with a grounded phase conductor, an isolation transformer with grounded neutral point (secondary side) must be connected between the line supply and the drive system in order to protect the motor insulation from a continuous and inadmissibly high stress level.

**3.8.2 Operating line connection components on the line supply**

The SINAMICS S120 Combi drive system is designed to be directly connected to TN, TT, and IT line supplies with a rated voltage of 3-ph. 380 V to 3-ph. 480 V AC.

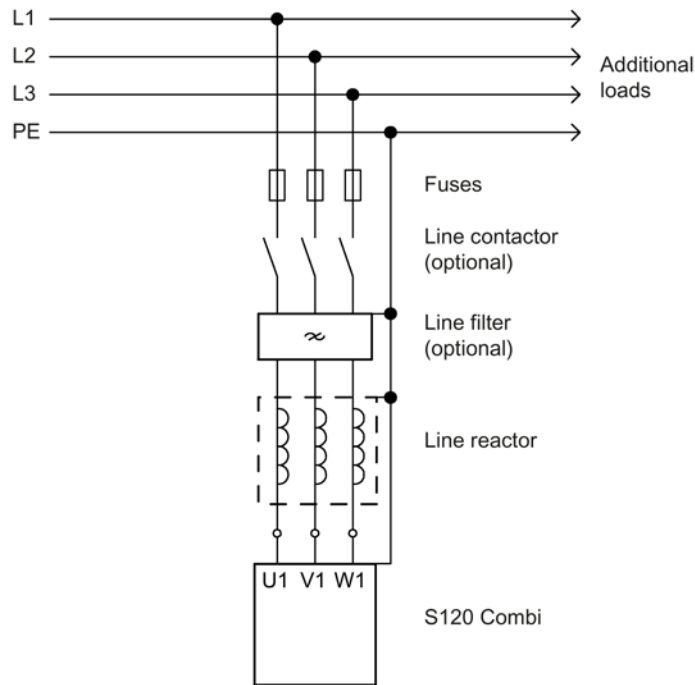

Figure 3-10 Direct operation on the line supply



### 3.8.3 Operation of the line connection components via a transformer

#### 3.8.3.1 Safety information

---

**Note**

If the system fault level is too low, this can result in faults at the integrated infeed of the SINAMICS S120 Combi Power Modules. It can also cause faults and damage to other equipment and devices that are connected to the same line connection point as the S120 Combi Power Module.

---

**Note**

Using a transformer with the S120 Combi Power Module does not replace the external line reactor.

---

#### 3.8.3.2 Line connection conditions

The S120 Combi is approved for operation on line supplies from  $S_{K \text{ line}}/P_n \geq 70$ .

If a TN line supply is specified on the secondary side, a transformer with grounded neutral point must be used. On the other hand, to trigger the fuse within the specified time, the loop resistance must be low enough.

#### Vector group

Any vector group with the neutral point brought out on the secondary side

### 3.8.3.3 Dimensioning an isolating transformer/autotransformer for several loads

An S120 Combi Power Module with integrated infeed and other loads / machines should be connected to the line supply via an isolating/autotransformer (matching transformer). The following diagram shows the connection using an isolating transformer as example.

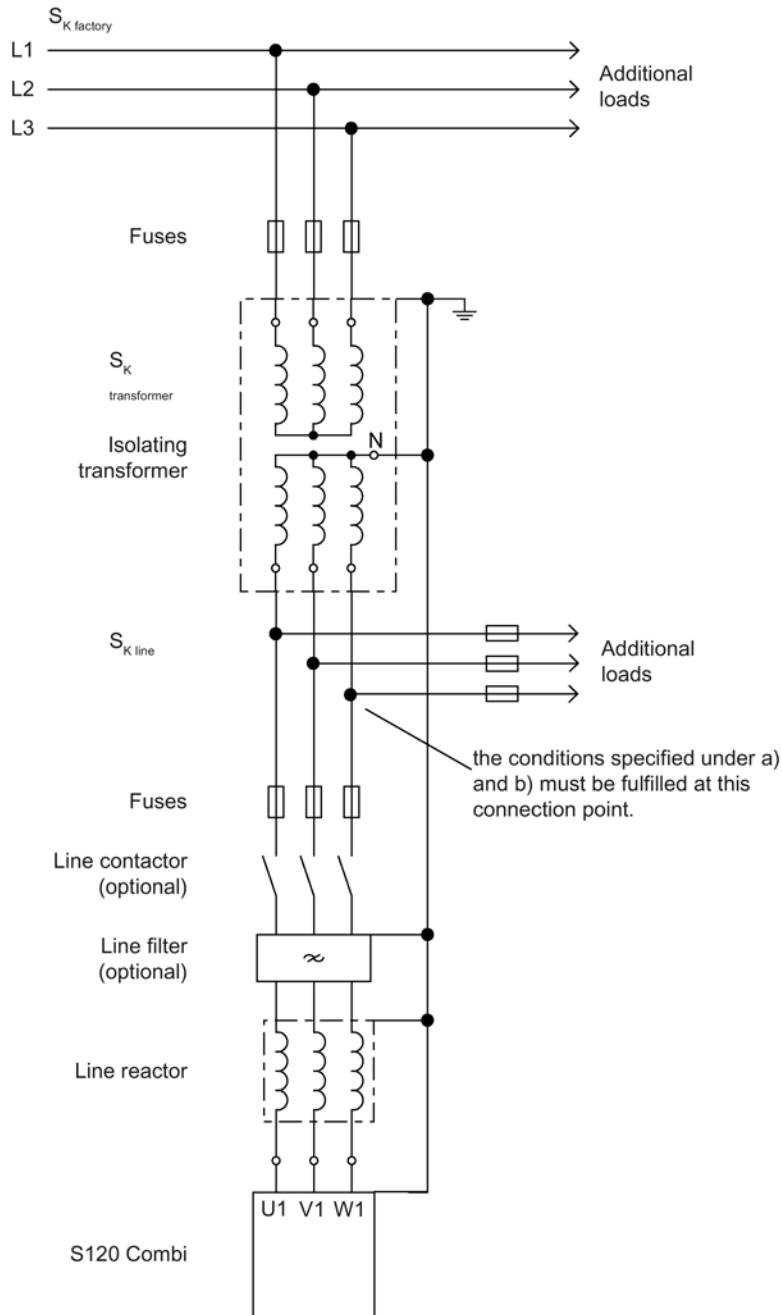

Figure 3-11 Operating several loads through an isolating transformer

An isolating/autotransformer (matching transformer) must be dimensioned for the total of all loads connected to it. The apparent powers required must be determined and added as indicated in the table titled "Transformer configuration instructions". If the transformer is too small ( $S_n$  or  $S_k$ ), this can lead to increased line voltage dips and faults in the line supply and in other loads at this connecting point.

If other loads are connected to the secondary side of the matching transformer, the boundary conditions indicated under a) and b) must be followed when selecting the matching transformer.

$S_{n1}$ ,  $S_{n2}$  = calculated rated power of the transformer resulting from a) and b)

$u_k$  = short-circuit voltage of the matching transformer in %  
(must be between 1% ... 3% for the S120 Combi)

$S_K$  = short-circuit power.



#### WARNING

**Danger to life through electric shock due to the connection of an unsuitable power supply**

If the short-circuit power is not sufficiently high enough to trip the fuse in the event of a fault, there is a risk of electric shock or fire.

- Use a power supply which generates a sufficient system fault level.

## Supplementary conditions

### a) Rated power

The rated power of the matching transformer  $S_{n1}$  must always be a factor of 1.27 higher than the rated power  $P_n$  of the S120 Combi Power Module.

$$S_{n1} \geq 1.27 \cdot P_n$$

Example:

The minimum rated power of a matching transformer for a 16 kW S120 Combi Power Module is 21 kVA.

### b) Short-circuit power

In order to avoid faults and disturbances at the other loads that are connected to the secondary side of the matching transformer, the total short-circuit power of the plant connection and that of the matching transformer at the connection point must reach the following values:

$$S_{K \text{ line}} \geq 70 \cdot P_n$$

Special case:

When operating with only one supply at a transformer, the values may be reduced by the factor 0.73.

$$S_{K \text{ line}} \geq 0.73 \cdot 70 \cdot P_n$$

For example  $S_{K \text{ line}}$  for 16 kW S120 Combi Power Module:  $S_{K \text{ line}} = 0.82 \text{ MVA} = 820 \text{ kVA}$

From  $S_{K \text{ transformer}}$  the required rated power of the matching transformer can be calculated.

$$S_{n2} = \frac{S_{K\ plant} [kVA] \cdot S_{K\ line} [kVA] \cdot u_k [\%]}{(S_{K\ plant} [kVA] - S_{K\ line} [kVA]) \cdot 100 [\%]} \quad [kVA]$$

**Note:**

The system fault level (short-circuit power) at the plant connection  $S_{K\ plant}$  plays a decisive role in dimensioning/selecting the matching transformer.

From the rated power ( $S_{n1}$  or  $S_{n2}$ ) calculated under a) and b), the higher value must be used for the matching transformer.

Table 3- 6 Transformer configuration instructions

S120 Combi Power Module $P_n$	Required rated power $S_n$ of the isolation transformer/autotransformer	Required short-circuit voltage $u_k$	Required system fault level $S_{K\ line}$
10 kW	$S_n \geq 13\ kVA$	$u_k \leq 3\ \%$	$S_{K\ line} \geq 0.7\ MVA$
16 kW	$S_n \geq 21\ kVA$	$u_k \leq 3\ \%$	$S_{K\ line} \geq 1.12\ MVA$
20 kW	$S_n \geq 26\ kVA$	$u_k \leq 3\ \%$	$S_{K\ line} \geq 1.4\ MVA$

**Note**

Ask your local power utility company for the system fault level  $S_{K\ line}$ .

**Example 1**

$u_k$  matching transformer = 3 %  
 $S_{K\ plant} = 50000\ kVA$   
 $S_{K\ line} = 16\ kW \cdot 70 \cdot 0.73 = 820\ kVA$

According to a)  
 $S_{n1} = 1.27 \cdot 16\ kW = 21\ kVA$

According to b)

$$S_{n2} = \frac{50000\ kVA \cdot 820\ kVA \cdot 3\%}{(50000\ kVA - 820\ kVA) \cdot 100\%} = 25\ kVA$$

$S_{n2} > S_{n1} \Rightarrow S_{n2}$  is decisive

The matching transformer requires a rated power  $S_n$  of 25 kVA for a short-circuit voltage  $u_k$  of 3%.

**Example 2**

$u_k$  matching transformer = 1 %  
 $S_{K \text{ plant}} = 50000 \text{ kVA}$   
 $S_{K \text{ line}} = 16 \text{ kW} \cdot 70 \cdot 0.73 = 820 \text{ kVA}$

according to a)  
 $S_{n1} = 1.27 \cdot 16 \text{ kW} = 21 \text{ kVA}$

According to b)

$$S_{n2} = \frac{50000 \text{ kVA} \cdot 820 \text{ kVA} \cdot 1\%}{(50000 \text{ kVA} - 820 \text{ kVA}) \cdot 100\%} = 8.3 \text{ kVA}$$

$S_{n1} > S_{n2} \Rightarrow S_{n1}$  is decisive

The matching transformer requires a rated power  $S_n$  of 21 kVA for a short-circuit voltage  $u_k$  of 1%.

**Example 3**

If  $S_{K \text{ plant}}$  is lower, then a higher-rating transformer must be used.

$u_k$  matching transformer = 3 %  
 $S_{K \text{ plant}} = 3000 \text{ kVA}$   
 $S_{K \text{ line}} = 16 \text{ kW} \cdot 70 \cdot 0.73 = 820 \text{ kVA}$

according to a)  
 $S_{n1} = 1.27 \cdot 16 \text{ kW} = 21 \text{ kVA}$

According to b)

$$S_{n2} = \frac{3000 \text{ kVA} \cdot 820 \text{ kVA} \cdot 3\%}{(3000 \text{ kVA} - 820 \text{ kVA}) \cdot 100\%} = 33.9 \text{ kVA}$$

$S_{n2} > S_{n1} \Rightarrow S_{n2}$  is decisive

The matching transformer requires a rated power  $S_n$  of 34 kVA for a short-circuit voltage  $u_k$  of 3%.

**Example 4**

If  $S_{K \text{ plant}}$  is lower, you can use, alternatively to example 3, a transformer with a lower  $u_k$ .

$u_k$  matching transformer = 1 %,  
 $S_{K \text{ plant}} = 3,000 \text{ kVA}$   
 $S_{K \text{ line}} = 16 \text{ kW} \cdot 70 \cdot 0.73 = 820 \text{ kVA}$

according to a)  
 $S_{n1} = 1.27 \cdot 16 \text{ kW} = 21 \text{ kVA}$

According to b)

$$S_{n2} = \frac{3000 \text{ kVA} \cdot 820 \text{ kVA} \cdot 1\%}{(3000 \text{ kVA} - 820 \text{ kVA}) \cdot 100\%} = 11.3 \text{ kVA}$$

$S_{n1} > S_{n2} \Rightarrow S_{n1}$  is decisive

The matching transformer requires a rated power  $S_n$  of 21 kVA for a short-circuit voltage  $u_k$  of 1%.

---

**Note**

$S_{n2}$  for the matching transformer can be reduced by reducing  $u_k$ . In the examples listed above, the power drawn from other loads has not been taken into account.

---

### 3.8.3.4 Operating line connection components via an autotransformer

An autotransformer can be used to adapt the voltage in the range up to 3-ph. 480 V AC 10 %.



**! WARNING**

**Danger to life through electric shock due to high voltage**

If the voltage applied is too high for the existing insulation, there is a danger of electric shock.

- Use an isolating transformer for voltages from 3-ph. 480 V + 10 %.

**NOTICE**

**Damage when using an autotransformer**

If an autotransformer is used, safe electrical separation is no longer possible for a line voltage higher than 480 V +10 %. This can lead to damage or a fault in the device.

- In this case, use an isolation transformer.

Application example:

- The motor insulation must be protected from excessive voltages.

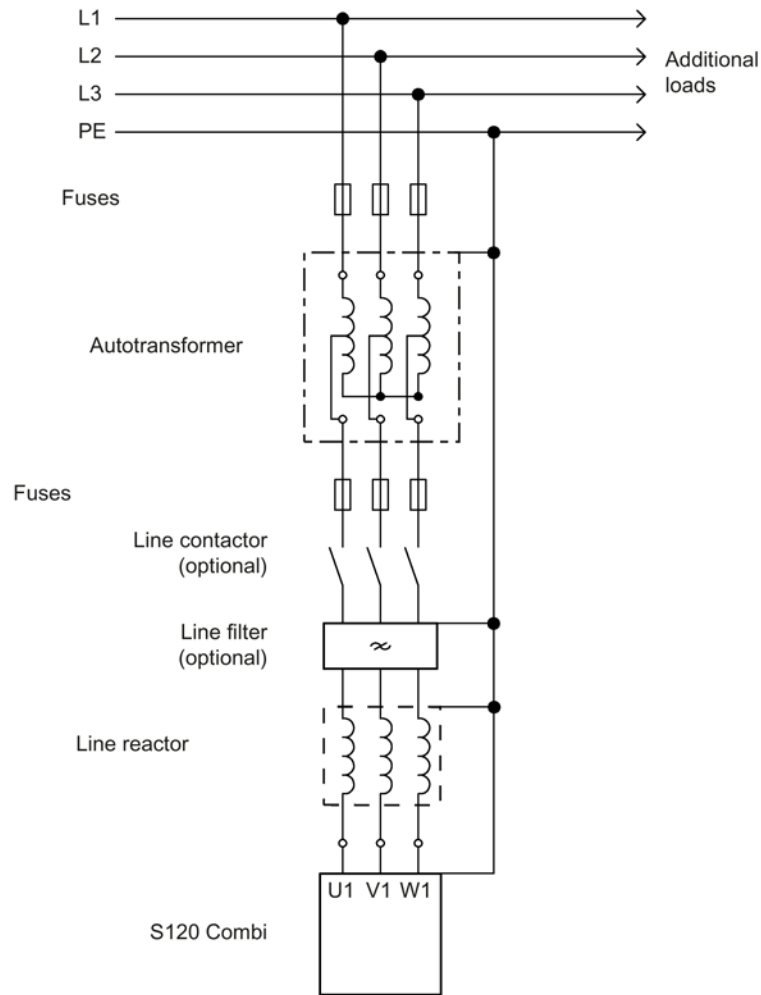

Figure 3-12 Operation via an autotransformer

### 3.8.3.5 Operating line connection components via an isolating transformer

An isolating transformer converts the line supply type of the plant or system (e.g. IT system) to a TN system. Additional voltage adaptation to the permissible voltage tolerance range is possible.

An isolating transformer must be used in the following cases:

- The insulation of the Motor Module and/or the motor is not suitable for the voltages that occur.
- There is no compatibility with an existing residual-current protective device.
- The installation altitude is higher than 2000 m above sea level.
- A line filter should be used in a line supply system that is not a TN line supply system with grounded neutral conductor.

An isolating transformer must have the following properties:

- The transformer secondary must be in the star connection (a delta connection is not permissible!).
- The neutral conductor must be brought out. It must be connected with the PE of the line filter, line reactor and S120 Combi (infeed).

**Notice:** If the neutral conductor is not brought out and/or not connected, then all of the restrictions of an IT line supply apply!



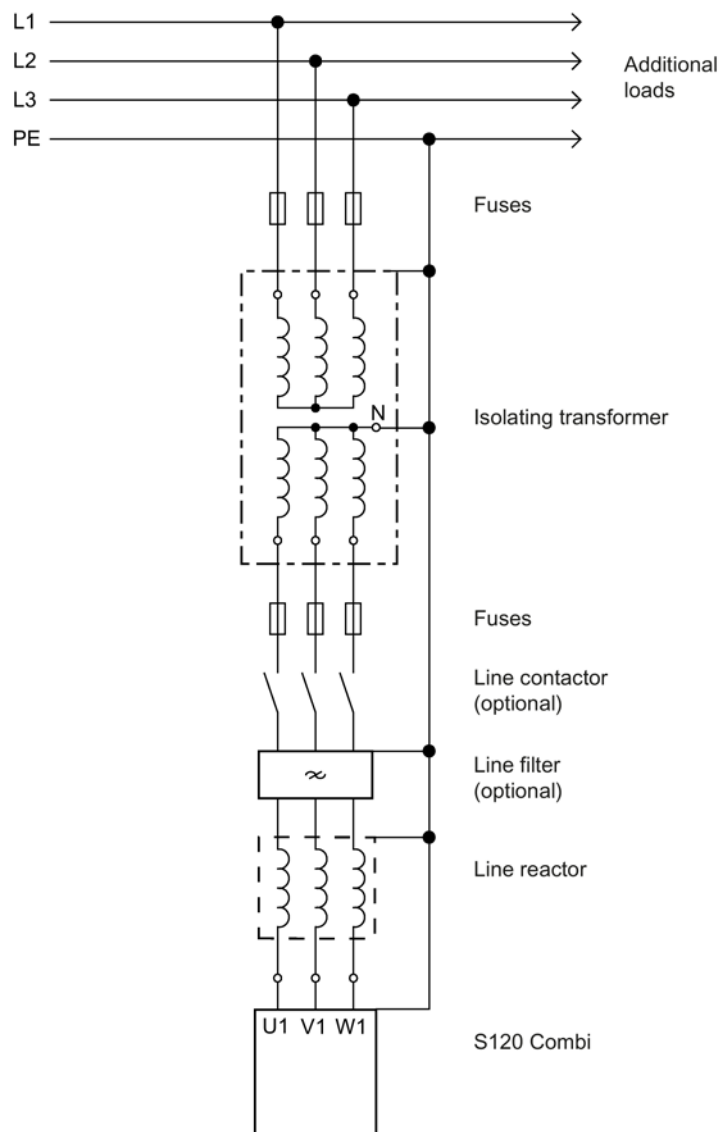

Figure 3-13 Operation via an isolation transformer



# S120 Combi Power Modules

## 4.1 Introduction

### 4.1.1 Description

#### The SINAMICS S120 Combi

The S120 Combi is a Power Module with integrated infeed, Motor Modules (inverter) for 3 or 4 axes and a TTL encoder evaluation for the spindle. The S120 Combi is available in the following versions for various current ratings:

- 3 axes Power Module with infeed, spindle and 2 feed axes
- 4 axes Power Module with infeed, spindle and 3 feed axes

The Power Modules are cooled using external air cooling that employs through-hole technology. The required fan unit is optionally available. A fan solution on the customer side with comparable rated data is possible.

The S120 Combi is capable of infeed/regenerative feedback (energy recovery). The infeed provides the integrated Motor Modules with an uncontrolled DC voltage.

In the infeed mode regarding the current and voltage waveforms, the infeed has a typical characteristic of a 6-pulse diode rectifier bridge. In the energy recovery mode, the current waveform is a square wave.

The energy recovery is switched in depending on the power that is fed back. Energy recovery is deactivated when the infeed is operating under no-load conditions.

The S120 Combi is suitable for direct operation on TN, IT and TT line supplies.

#### Controlling the motor holding brake

The S120 Combi has an integrated brake control function for a motor holding brake. The motor holding brake is connected at terminal X11. The assignment of the motor holding brake to the feed axes of the S120 Combi can be freely parameterized using the software. Motor holding brakes up to 1 A are controlled.

#### Temperature sensor connection

A temperature sensor can either be connected using terminal X21 or using the sub-D connector of the TTL encoder (X220). The interface used is selected using the software.

**Encoder connection**

The S120 Combi supports sin/cos encoders, TTL encoders and encoders with integrated DRIVE-CLiQ with a 5 V supply for motors. The TTL encoder is connected via the integrated X220 encoder interface and is permanently assigned to spindle output X2. The sin/cos encoder for spindle output X2 is connected to interface X205 via an SMxxx Sensor Module. In this particular case, encoder interface X220 is automatically inactive.

Fixed topology rules apply when connecting DRIVE-CLiQ encoders. Each feed axis is assigned exactly to one DRIVE-CLiQ interface (see Section Topology rules for DRIVE-CLiQ (Page 131)).

HTL encoders, SSI encoders and a 24 V encoder power supply are not supported by the integrated encoder interface on the S120 Combi.

**Interface assignment**

The assignment of the DRIVE-CLiQ interfaces on the S120 Combi is permanently defined and must not be changed.

The DRIVE-CLiQ connection of the expansion axes is always implemented via DRIVE-CLiQ interface X101 at the SINUMERIK control. You can find a detailed description in Chapters Interface description (Page 75) of the S120 Combi and Topology rules for DRIVE-CLiQ (Page 131).

Measuring systems and additional encoders should always be connected via the DMC20 Hub Module.

**Internal temperature sensing and internal fan**

The internal temperature of the S120 Combi is sensed. In conjunction with this is the temperature-dependent control of the internal fan to cool the inside of the unit. The S120 Combi Power Module is switched off if its internal temperature becomes too high.

An operating hours counter for the internal fan is available via the software in parameter P0254 (infeed) (see SINAMICS S120/S150 List Manual).

**Accessories pack for S120 Combi**

The S120 Combi is supplied with an accessory pack.

Designation	Article number
S120 Combi accessories pack <b>Contents:</b> 24 V connector Terminal for the motor holding brake 4 DRIVE-CLiQ blanking covers 2 terminals (4-pole) for X12/X13 2 terminals (4-pole) for X21/X22 5 shield terminals for motor cables Shield terminal for EP signal cables	6SL3161-8AP00-0AA0

## 4.1.2 Module versions

Table 4- 1 S120 Combi versions

Infeed [kW]	Spindle Motor Module 1 [A <sub>rms</sub> ]	Feedrate 1 Motor Module 2 [A <sub>rms</sub> ]	Feedrate 2 Motor Module 3 [A <sub>rms</sub> ]	Feedrate 3 Motor Module 4 [A <sub>rms</sub> ]	Article number
<b>3 axes</b>					
16	18	5	5	-	6SL3111-3VE21-6FA0
16	24	9	9	-	6SL3111-3VE21-6EA0
20	30	9	9	-	6SL3111-3VE22-0HA0
<b>4 axes</b>					
10	24 <sup>1)</sup>	12	12	12	6SL3111-4VE21-0EA0
16	18	9	5	5	6SL3111-4VE21-6FA0
16	24	9	9	9	6SL3111-4VE21-6EA0
20	30	12	9	9	6SL3111-4VE22-0HA0

1) Pulse frequency, 4 kHz / 8 kHz

### 4.1.3 Approved controls

The S120 Combi is approved for operation with the following controls:

- SINUMERIK 828D with PPU versions
  - PPU 24..2
  - PPU 26..2
  - PPU 28..2
  - PPU 24..3
  - PPU 26..3
  - PPU 28..3

Table 4- 2 Overview of the article numbers of the approved SINUMERIK 828D controls

PPU version	Keyboard	Article number (without CNC software)
240.2	Vertical	6FC5370-4AT20-0AA0 (Turning) 6FC5370-4AM20-0AA0 (Milling)
241.2	Horizontal	6FC5370-3AT20-0AA0 (Turning) 6FC5370-3AM20-0AA0 (Milling)
260.2	Vertical	6FC5370-6AA20-0AA0
261.2	Horizontal	6FC5370-5AA20-0AA0
280.2	Vertical	6FC5370-8AA20-0AA0
281.2	Horizontal	6FC5370-7AA20-0AA0
240.3	Vertical	6FC5370-4AA30-0AA0
241.3	Horizontal	6FC5370-3AA30-0AA0
260.3	Vertical	6FC5370-6AA30-0AA0
261.3	Horizontal	6FC5370-5AA30-0AA0
280.3	Vertical	6FC5370-8AA30-0AA0
281.3	Horizontal	6FC5370-7AA30-0AA0

- SINUMERIK 840D sl with NCU versions
  - NCU 710.3 PN

Table 4- 3 Overview of the article numbers of the approved SINUMERIK 840D controls

NCU version	Article number (without CNC software)
710.3	6FC5371-0AA30-0AA1

#### 4.1.4 Expansion axes that can be connected

The S120 Combi can be expanded with Motor Modules from the SINAMICS S120 Booksize Compact series by 1 or 2 axes.

Table 4- 4 Expansion axes for the S120 Combi Power Modules

Motor Module Booksize Compact	Width	Article number
Single Motor Module 3 A	50 mm	6SL3420-1TE13-0AA.
Single Motor Module 5 A	50 mm	6SL3420-1TE15-0AA.
Single Motor Module 9 A	50 mm	6SL3420-1TE21-0AA.
Single Motor Module 18 A	75 mm	6SL3420-1TE21-8AA.
Double Motor Module 2 x 1.7 A	75 mm	6SL3420-2TE11-7AA.
Double Motor Module 2 x 3 A	75 mm	6SL3420-2TE13-0AA.
Double Motor Module 2 x 5 A	75 mm	6SL3420-2TE15-0AA.

---

#### Note

##### Number of expansion axes

A maximum of 2 expansion axes can be connected to an S120 Combi Power Module, i.e. two Single Motor Modules or one Double Motor Module.

---

Description of the Booksize Compact Motor Modules, see Section Motor Modules Booksize Compact as expansion axes (Page 139).

## 4.2 Safety information

 **WARNING**

**Danger to life if the fundamental safety instructions and remaining risks are not carefully observed**

If the fundamental safety instructions and remaining risks in Chapter 1 (Page 21) are not observed, accidents involving severe injuries or death may occur.

- Adhere to the fundamental safety instructions.
- When assessing the risk, take into account residual risks.



 **DANGER**

**Danger to life through electric shock due to connection to the line supply**

If the S120 Combi is not disconnected from the line supply system (e.g. via the line contactor or main switch), the DC link remains charged.

Contact with live parts can result in death or serious injury.

- Before starting any maintenance work, disconnect the S120 Combi from the line supply using the line contactor or main switch.



 **DANGER**

**Danger to life through electric shock due to residual charge**

A hazardous voltage is still present for up to 5 minutes after the power supply has been switched off.

Contact with live parts can result in death or serious injury.

- Remove the front plate only after 5 minutes have passed.
- When using expansion axes, check that the DC link connection is in a no-voltage condition (de-energized).
- Only operate the S120 Combi when the front plate is mounted.
- When operating without expansion axes, do not remove the factory-mounted DC link cover.
- Do not continue to operate damaged components.



 **WARNING**

**Danger to life through electric shock due to contact with unused terminals X1 and X2**

If cables are not connected to the terminals X1 (line connection) and X2 (motor connection - spindle), contact can result in death or serious injury.

- Before starting any work on the connections, check for zero voltage.





**! WARNING**

**Danger to life through electric shock as well as fire hazard due to overcurrent protective devices that trip too late**

Overcurrent protective devices that do not trip or trip too late can cause an electric shock or fire.

- To protect personnel and for fire protection purposes, at the infeed point, the short-circuit rating and loop impedance must correspond to the specifications in the documentation in order for the installed overcurrent protection devices to trip within the specified time.



**! WARNING**

**Danger to life through interruption of the external protective conductor due to high leakage currents**

The drive components conduct a high leakage current via the protective conductor. Touching conductive parts when the protective conductor is interrupted can result in death or serious injury.

- Ensure that the external protective conductor satisfies at least one of the following conditions:
    - It has been laid so that it is protected against mechanical damage.<sup>1)</sup>
    - If it is a single cable, it has a cross-section of at least 10 mm<sup>2</sup> Cu.
    - If it is a conductor of a multi-conductor cable, it has a cross-section of at least 2.5 mm<sup>2</sup> Cu.
    - It has a second protective conductor in parallel with the same cross-section.
    - It complies with the local regulations for equipment with increased leakage current.
- <sup>1)</sup> Cables laid within control cabinets or closed machine housings are considered to be adequately protected against mechanical damage.



**! WARNING**

**Danger to life through electric shock due to incorrectly laid brake cables**

If brake cables are laid without safe electrical separation, the insulation can fail with an electric shock.

- Close the holding brake with the specified MOTION-CONNECT cable.
- Only use third-party cables with safe electrically separated brake cores or lay the brake cores with safe electrical separation.



<b>WARNING</b>
<p><b>Danger to life from electric shock in the event of voltage flashovers at the temperature sensor</b></p> <p>Voltage flashovers in the signal electronics can occur in motors without safe electrical separation of the temperature sensors.</p> <ul style="list-style-type: none"> <li>• Only use temperature sensors that fully comply with the specifications of the safety isolation.</li> <li>• If protective separation cannot be guaranteed (with linear motors or third-party motors, for example), use a Sensor Module External (SME120 or SME125) or the TM120 Terminal Module.</li> </ul>

<b>WARNING</b>
<p><b>Fire hazard due to overheating because of inadequate ventilation clearances</b></p> <p>Inadequate ventilation clearances can cause overheating with a risk for personnel through smoke development and fire. This can also result in more downtimes and Line Modules may have a reduced service life.</p> <ul style="list-style-type: none"> <li>• It is absolutely essential that you maintain ventilation clearances according to the table Ventilation clearances above and below the component (Page 310).</li> </ul>

<b>WARNING</b>
<p><b>Fire hazard due to overheating when permissible cable lengths are exceeded</b></p> <p>Excessively long cable lengths can cause components to overheat with the associated risk of fire and development of smoke.</p> <ul style="list-style-type: none"> <li>• The total length of the power cables (motor feeder cables etc.) must not exceed 175 m.</li> </ul>

<b>WARNING</b>
<p><b>Fire hazard and damage to devices during operation without a line reactor</b></p> <p>Operating a system without a line reactor can trigger a fire with smoke development.</p> <ul style="list-style-type: none"> <li>• Do not operate the system without a line reactor.</li> </ul>

<b>NOTICE</b>
<p><b>Material damage due to loose power connections</b></p> <p>Insufficient tightening torques or vibrations can result in faulty electrical connections. This can cause fire damage or malfunctions.</p> <ul style="list-style-type: none"> <li>• Tighten all the DC link busbar screws with the specified tightening torques (1.8 Nm tolerance +30 %).</li> <li>• Check the tightening torques of all power connections at regular intervals and tighten them when required. This applies in particular after transport.</li> </ul>

**NOTICE****Damage through use of incorrect DRIVE-CLiQ cables**

Damage or malfunctions can occur on the devices or system when incorrect or unreleased DRIVE-CLiQ cables are used.

- Only use suitable DRIVE-CLiQ cables that have been approved by Siemens for the particular application.

---

**Note****Operation on line supplies where energy recovery is not possible**

In line supply systems without energy recovery capability (e.g. a diesel generator), device faults can occur due to a lack of dissipation of braking energy.

- Deactivate the energy recovery capability of the Smart Line Modules using the corresponding parameter (see the SINAMICS S120/S150 List Manual).
- The braking energy must then be dissipated via an additional Braking Module with braking resistor in the drive line-up.

---

**Note****Shutting down the device in the event of contaminated external heat sinks**

For components with external air cooling, the fan and the heat sinks can accumulate a lot of pollution. If the cooling air requirement is not provided by the filter fan, the components cannot output their specified power. This can cause the temperature monitoring function in the components to respond.

- Check the fans and heat sinks for pollution at regular intervals and clean them when necessary.
- 

## 4.3 Interface description

---

**Note**

For the S120 Combi Power Module 6SL3111-4VE21-0EA0, a trip protection grid is provided when it is shipped from the factory. For all other S120 Combi Power Modules, it can be ordered as replacement part and retrofitted.

---

### 4.3.1 Overview diagrams

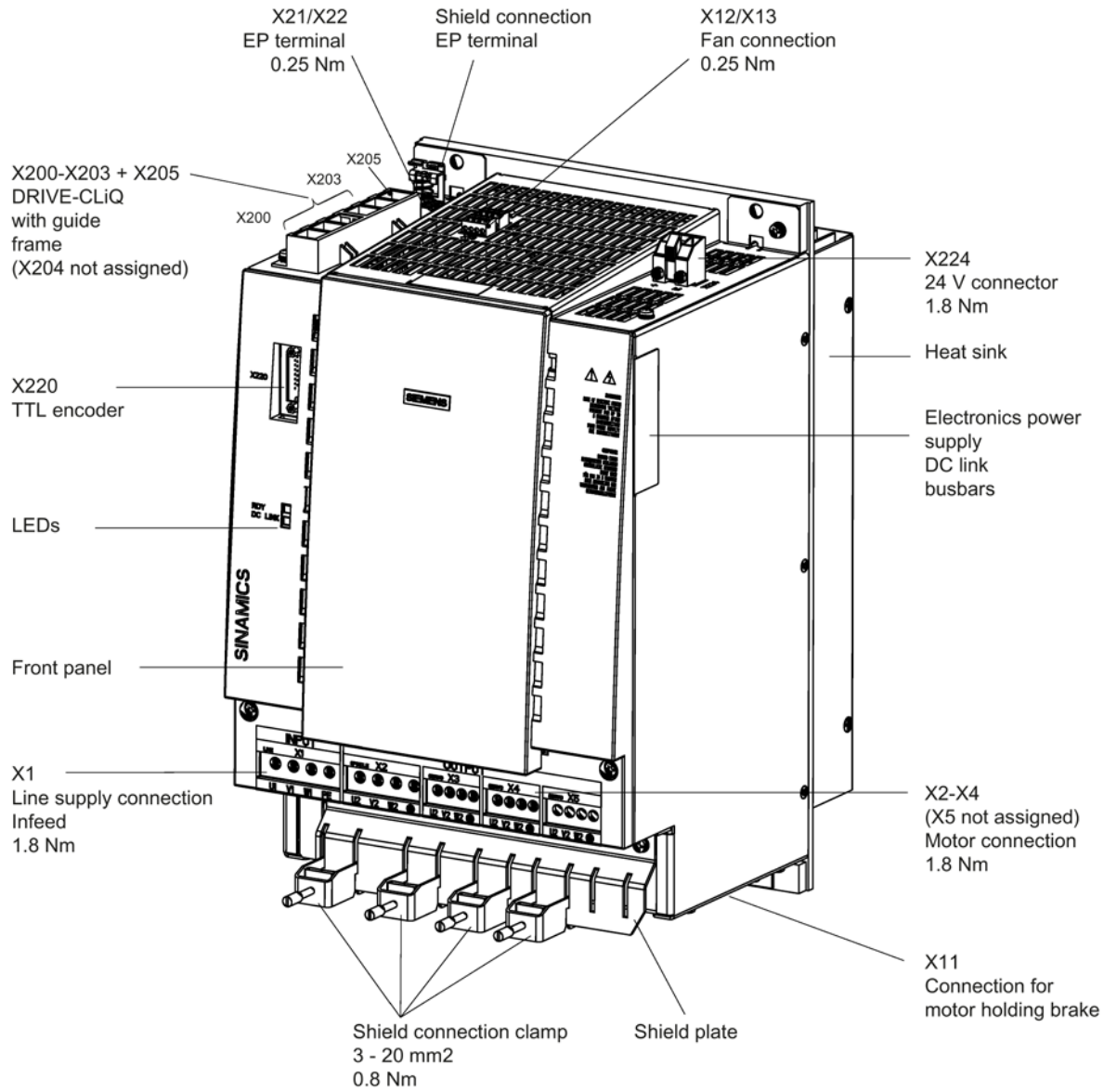
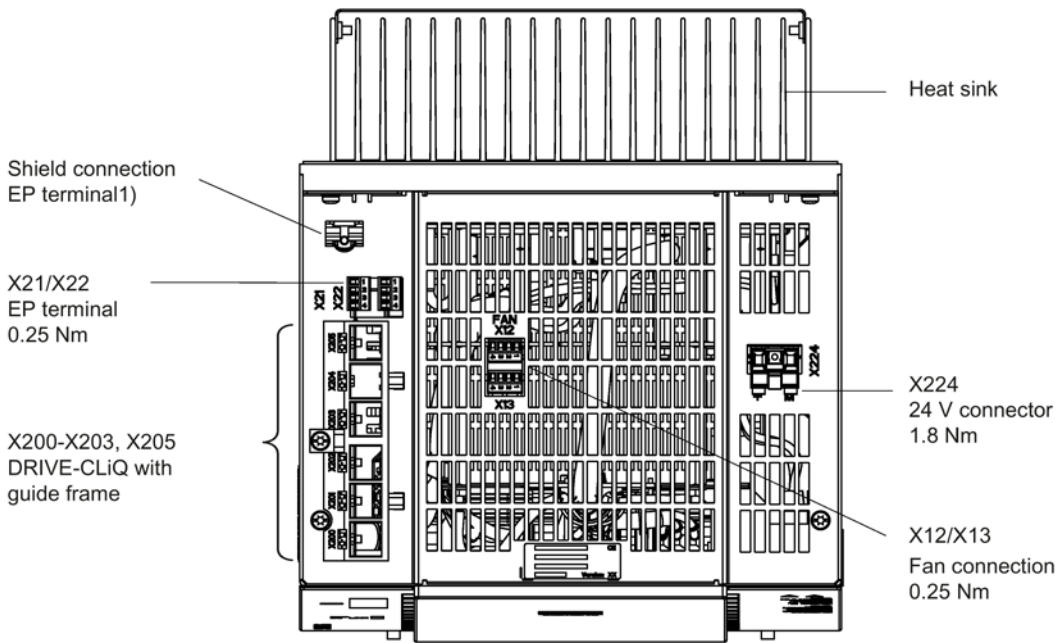

Figure 4-1 S120 Combi 3 axes Power Module



1) The shield connection terminal is included in the accessories pack (Weidmüller, type KLBÜ 3-8 SC)

Figure 4-2 S120 Combi 3 axes Power Module: View from the top

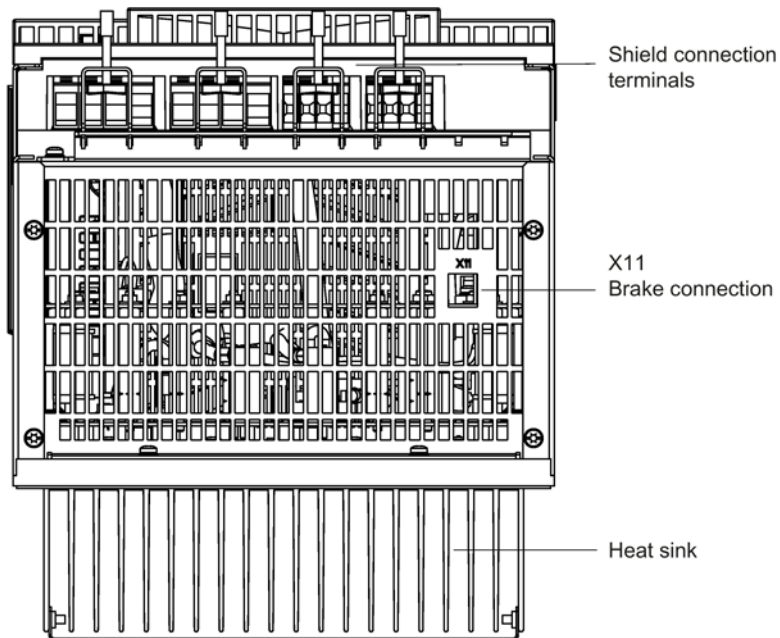

Figure 4-3 S120 Combi 3 axes Power Module: View from below

4.3 Interface description

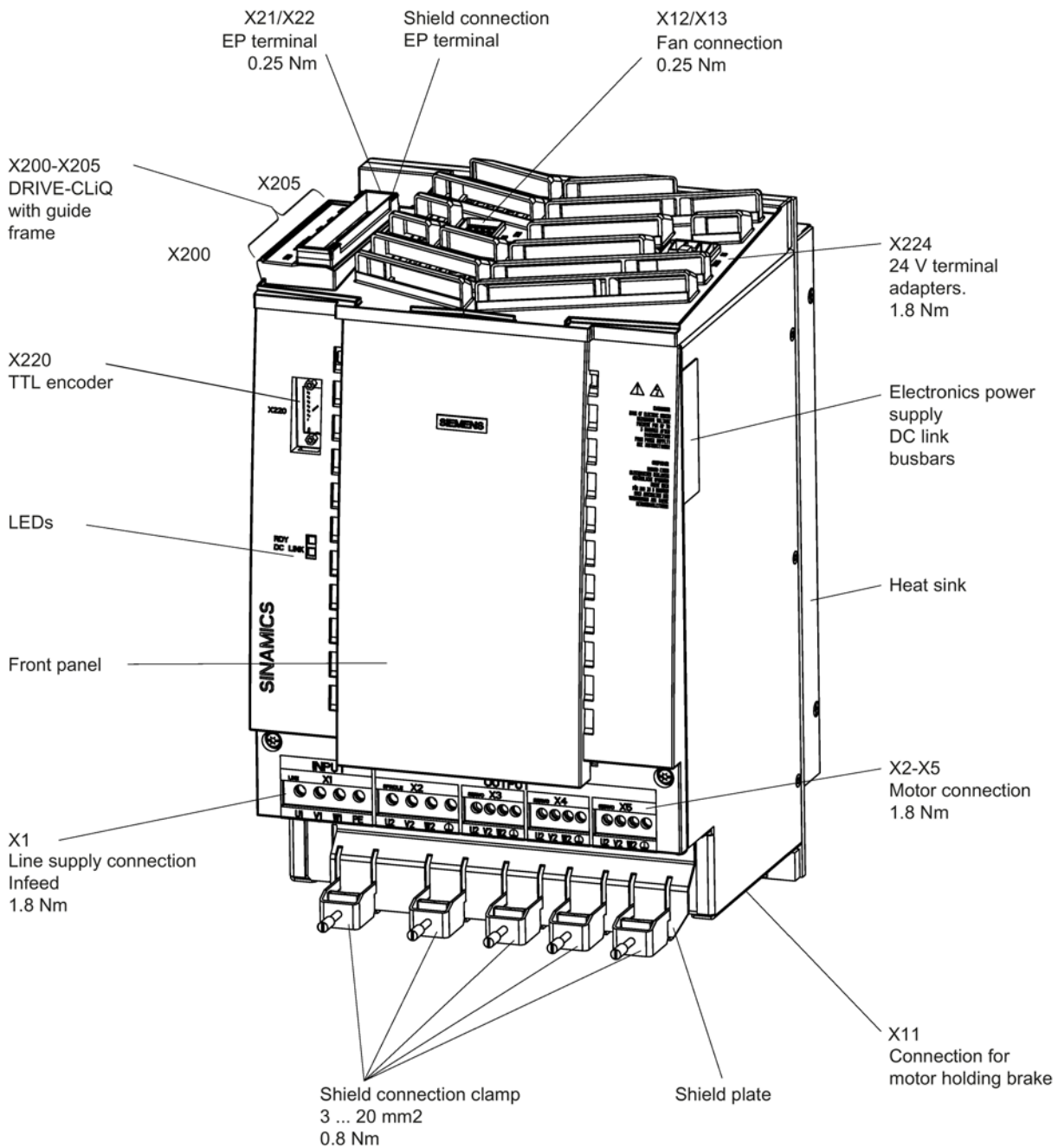
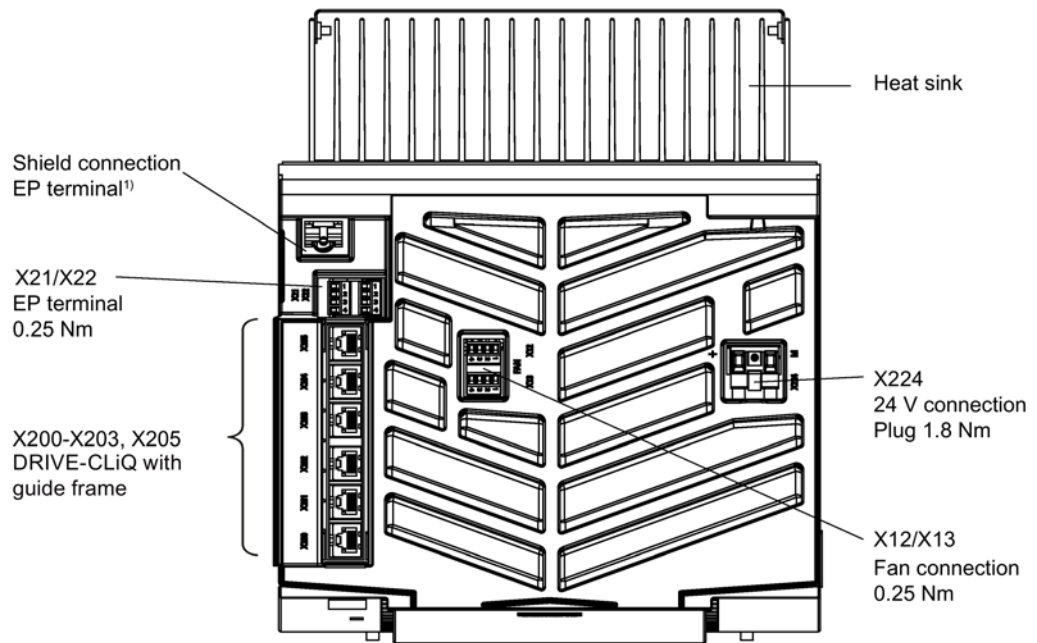

Figure 4-4 S120 Combi 4 axes Power Module



1 The shield connection terminal is included in the accessories pack (Weidmüller, type KLBÜ 3-8 ) SC)

Figure 4-5 S120 Combi 4 axes Power Module: View from the top

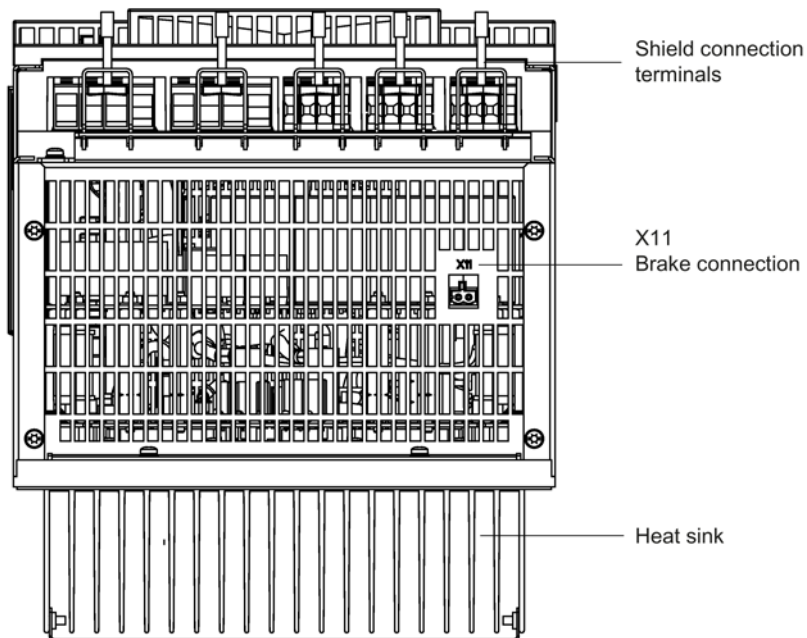
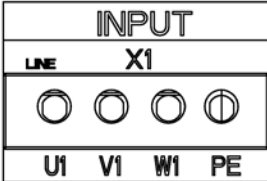

Figure 4-6 S120 Combi 4 axes Power Module: View from below

4.3 Interface description

4.3.2 X1 line connection

Table 4- 5 X1 line connection (infeed)

	Terminal	Technical data
	U1	Type: Screw terminal 7 (Page 307)
	V1	Max. connectable cross-section: 16 mm <sup>2</sup>
	W1	Tightening torque: 1.5 ... 1.8 Nm
	PE connection	

4.3.3 X2-X5 motor connection

Table 4- 6 X2 spindle (18 A, 24 A and 30 A Motor Modules)

	Terminal	Technical data
	U2	Type: Screw terminal 6 (Page 307)
	V2	Max. connectable cross-section: 10 mm <sup>2</sup>
	W2	Tightening torque: 1.5 ... 1.8 Nm
	PE connection	



Table 4- 7 X3 to X5 feedrate (5 A, 9 A and 12 A Motor Modules)

	Terminal	Technical data
	U2	Type: Screw terminal 5 (Page 307)
	V2	Max. connectable cross-section: 6 mm <sup>2</sup>
	W2	Tightening torque: 1.5 ... 1.8 Nm
	PE connection	
 <p>Only for 4-axis Power Modules:</p>		
		

**Note**

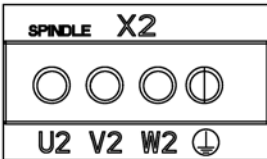
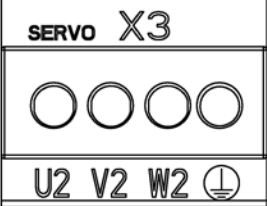
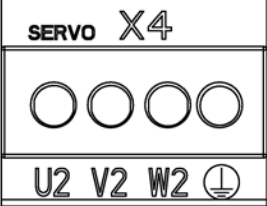
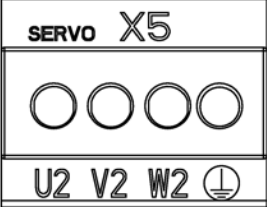
The total length of the power cables must not exceed 175 m.

### 4.3.4 X11 brake connection

Table 4- 8 Brake connection X11

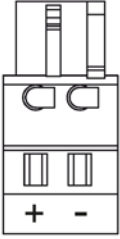
	Terminal	Designation	Technical data
Connectors: 	BR +	Brake connection +	Voltage: 24 V DC Max. load current: 1 A Minimum load current: 0.1 A Type: Spring-loaded terminal 1 (Page 306) Max. connectable cross-section: 2.5 mm <sup>2</sup> The brake connector is part of the prefabricated cable.
	BR -	Brake connection -	



 <b>WARNING</b>
<p><b>Danger to life through electric shock due to a terminal voltage that has not been adjusted</b></p> <p>Contact with live terminals can result in death or serious injury.</p> <ul style="list-style-type: none"> <li>• Only connect protective extra-low voltages (PELV or SELV) to all connections and terminals between 0 and 48 V DC.</li> <li>• Observe the voltage tolerances of the motor holding brakes (24 V ± 10%).</li> </ul>

**Note**

The motor brake must be connected via connector X11. The BR- cable must not be connected directly to electronics ground (M).

### 4.3.5 X12/X13 fan connection

Table 4- 9 X12/X13 connection of the external fan unit

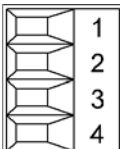
	Terminal	Designation	Technical data
	1	Ground	Current-carrying capacity (24 V): 2 x 1 A or 1 x 2 A Type: Screw terminal 1 (Page 307) Max. connectable cross-section: 1.5 mm <sup>2</sup> Tightening torque: 0.22 ... 0.5 Nm
	2	Fan monitoring	
	3	+24 V	
	4	Ground	

---

#### Note

##### Connecting a fan assembly with 2-core cables

When connecting a customer's own fan assembly using 2-core cables, an error message appears regarding the fan.

- Connect terminals 1 and 2 with a jumper.
- 

#### Note

When connecting a customer's own fan assembly using 3-core cables, the white core (high fault signal = fault) can be connected to terminal 2.

---

4.3 Interface description

4.3.6 X21/X22 EP terminals

Table 4- 10 X21 EP terminals - infeed

	Terminal	Designation	Technical data
	1	-	Reserved, do not use
	2	-	
	3	EP +24 V (Enable Pulses)	Supply voltage: 24 V DC (20.4 ... 28.8 V) Current consumption, typical: 4 mA at 24 V Isolated input
	4	EP M1 (Enable Pulses)	

Table 4- 11 X22 EP terminal/temperature sensor - axes

	Terminal	Designation	Technical data
	1	+ Temp	Temperature sensors <sup>1)</sup> : KTY84–1C130 / PT1000 / PTC / bimetallic switch with NC contact
	2	- Temp	
	3	EP +24 V (Enable Pulses)	Supply voltage: 24 V DC (20.4 ... 28.8 V) Current consumption, typical: 4 mA at 24 V Isolated input The pulse inhibit function is only available when Safety Integrated Basic Functions are enabled.
	4	EP M1 (Enable Pulses)	

<sup>1)</sup> The temperature sensor type can be selected by parameter (see the SINAMICS S120/S150 List Manual).

**! WARNING****Danger to life through electric shock due to temperature sensors that are not permitted**

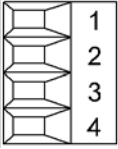
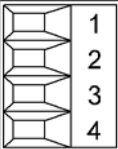
If temperature sensors that do not comply with the safety isolation specifications are connected to terminals "+Temp" and "-Temp", there is a risk of electric shock.

- Only use temperature sensors that fully comply with the specifications of the safety isolation.

**NOTICE****Damage due to overheating, caused by a KTY temperature sensor that has been incorrectly connected**

If the KTY temperature sensor was not connected with the correct polarity, motor overheating may not be detected.

- Connect the KTY temperature sensor with the correct polarity.

**Note**

The function of the EP terminals is only available when Safety Integrated Basic Functions are enabled.

**Note**

The temperature sensor input is not needed if the motors feature an integrated DRIVE-CLiQ interface or if temperature values are detected by means of a different module (SMC, SME).

### 4.3.7 X200-X205 DRIVE-CLiQ interfaces

Table 4- 12 X200-X205 DRIVE-CLiQ interfaces

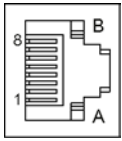
	PIN	Signal name	Technical data
	1	TXP	Transmit data +
	2	TXN	Transmit data -
	3	RXP	Receive data +
	4	NC	
	5	NC	
	6	RXN	Receive data -
	7	NC	
	8	NC	
	A	+ (24 V)	Power supply
	B	M (0 V)	Electronics ground
Connector type	DRIVE-CLiQ socket		

The blanking covers for the DRIVE-CLiQ interfaces are included in the scope of delivery.

Blanking covers (50 x) Article number: 6SL3066-4CA00-0AA0

**Note**

**DRIVE-CLiQ interface X204**

For 3 axes Power Modules of the S120 Combi, there is no DRIVE-CLiQ interface X204.

### Inserting and removing the DRIVE-CLiQ blanking covers

Blanking covers should be attached to the DRIVE-CLiQ interfaces that are not required.

To remove the blanking covers, we recommend that the guiding frame is dismantled. To do this, first remove all of the connections and the drip protection grid. Then remove the Torx slotted screw (see below).

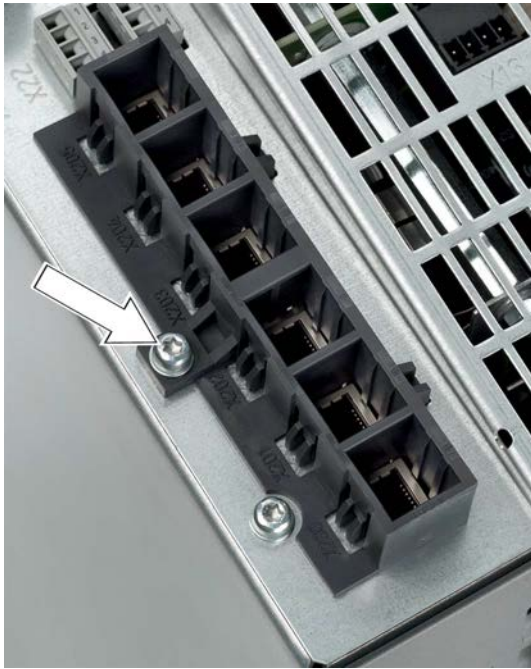
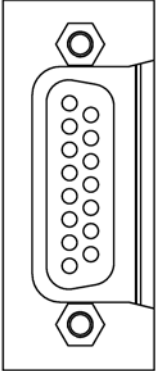

Figure 4-7 Dismantling the guiding frame of the DRIVE-CLiQ interfaces

As an alternative to dismantling the guiding frame, flat-nosed pliers can be used to remove the blanking covers.

### 4.3.8 X220 TTL encoder

Table 4- 13 Encoder interface X220

	Pin	Signal name	Technical data
	1	+ Temp	Motor temperature sensing KTY84-1C130 (KTY+) Temperature sensor KTY84-1C130 / PTC
	2	Clock	Clock
	3	Clock*	Inverse clock
	4	P encoder 5 V	Encoder power supply
	5	P encoder 5 V	
	6	P sense	Sense input of encoder power supply
	7	M encoder (M)	Ground for encoder power supply
	8	- Temp	Motor temperature sensing KTY84-1C130 (KTY+) Temperature sensor KTY84-1C130 / PTC
	9	M sense	Ground sense input
	10	R	Reference signal R
	11	R*	Inverse reference signal R
	12	B*	Inverse incremental signal B
	13	B	Incremental signal B
	14	A*	Inverse incremental signal A
	15	A	Incremental signal A

Type: Sub-D socket, 15-pin; TTL encoder; max. cable length 100 m

**Note**

Only 5 V TTL encoders are supported.



**! WARNING**

**Danger to life through electric shock due to temperature sensors that are not permitted**

If temperature sensors that do not comply with the safety isolation specifications are connected to terminals "+Temp" and "-Temp", there is a risk of electric shock.

- Only use temperature sensors that fully comply with the specifications of the safety isolation.



Table 4- 14 Technical data of the encoder system supply

Encoder system supply	Unit	Value
Voltage	V <sub>DC</sub>	5 (with or without remote sense) <sup>1)</sup>
Current	A <sub>DC</sub>	0,35
Encoder frequency that can be evaluated (f <sub>encoder</sub> )	kHz	≤ 300

- 1) A controller compares the encoder system supply voltage - sensed via the remote sense cables - with the reference supply voltage of the encoder system, and adjusts the supply voltage for the encoder system at the output of the drive module until the required supply voltage is obtained directly at the encoder system.

Table 4- 15 Specification of TTL encoder systems that can be connected

Parameter	Designation	Threshold	Min.	Max.	Unit
Signal level, high <sup>1)</sup>	U <sub>Hdiff</sub>		2	5	V
Signal level, low <sup>1)</sup>	U <sub>Ldiff</sub>		-5	-2	V
Signal frequency	f <sub>S</sub>		-	300	kHz
Edge clearance	t <sub>min</sub>		100	-	ns
"Zero pulse inactive time" (before and after A=B=high)	t <sub>Lo</sub>		640	(t <sub>ALo-BHi</sub> - t <sub>Hi</sub> )/2 <sup>2)</sup>	ns
"Zero pulse active time" (while A=B=high and beyond) <sup>3)</sup>	t <sub>Hi</sub>		640	t <sub>ALo-BHi</sub> - 2*t <sub>Lo</sub> <sup>2)</sup>	ns

- 1) Other signal levels according to the RS 422 standard.
- 2) t<sub>ALo-BHi</sub> is not a specified value, but is the time between the falling edge of track A and the next but one rising edge of track B.
- 3) Further information on setting the "Zero pulse active time" can be found in the following:  
References: SINAMICS S120 Function Manual (FH1), tolerant encoder monitoring for SMC30

Encoder current as a function of the cable length for encoders with remote sense with 5 V supply (applicable for cable cross-sections of 0.5 mm<sup>2</sup>):

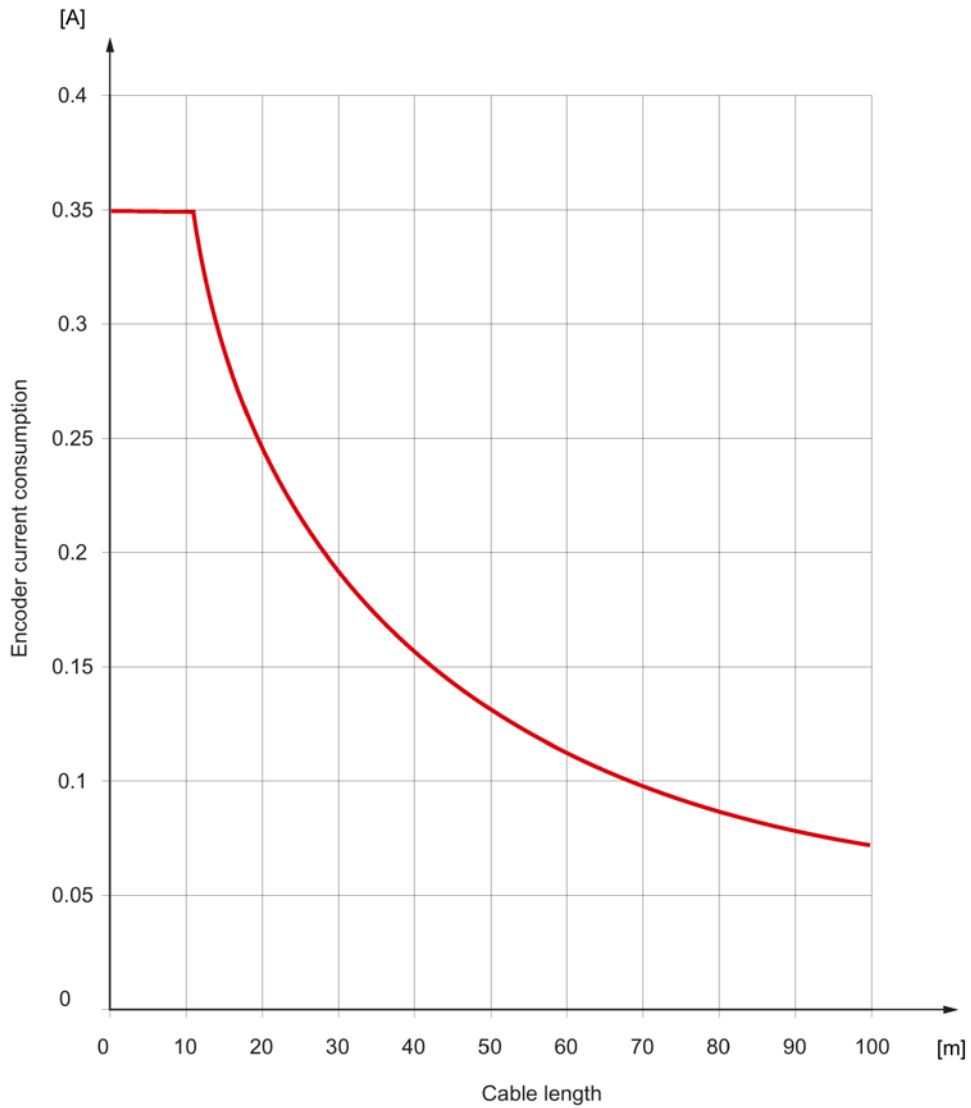

Figure 4-8 Encoder current drawn as a function of the maximum cable length

For encoders without remote sense the permissible cable length is restricted to 100 m (reason: the voltage drop depends on the cable length and the encoder current).

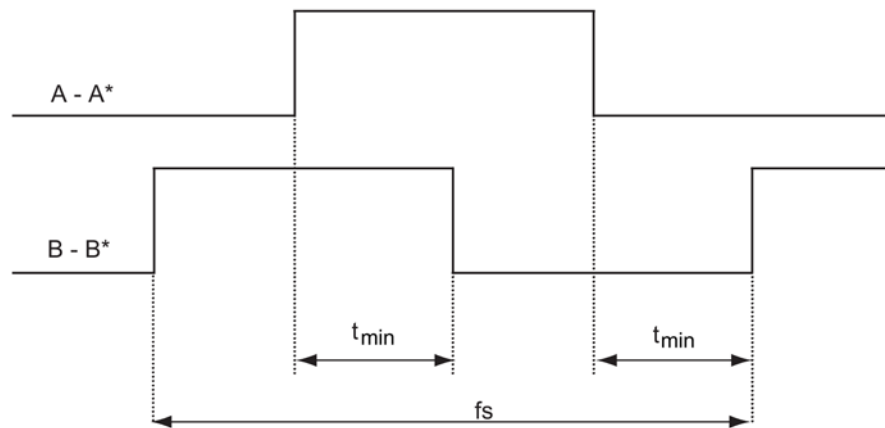

Figure 4-9 Signal characteristic of track A and track B between two edges: Time between two edges with pulse encoders

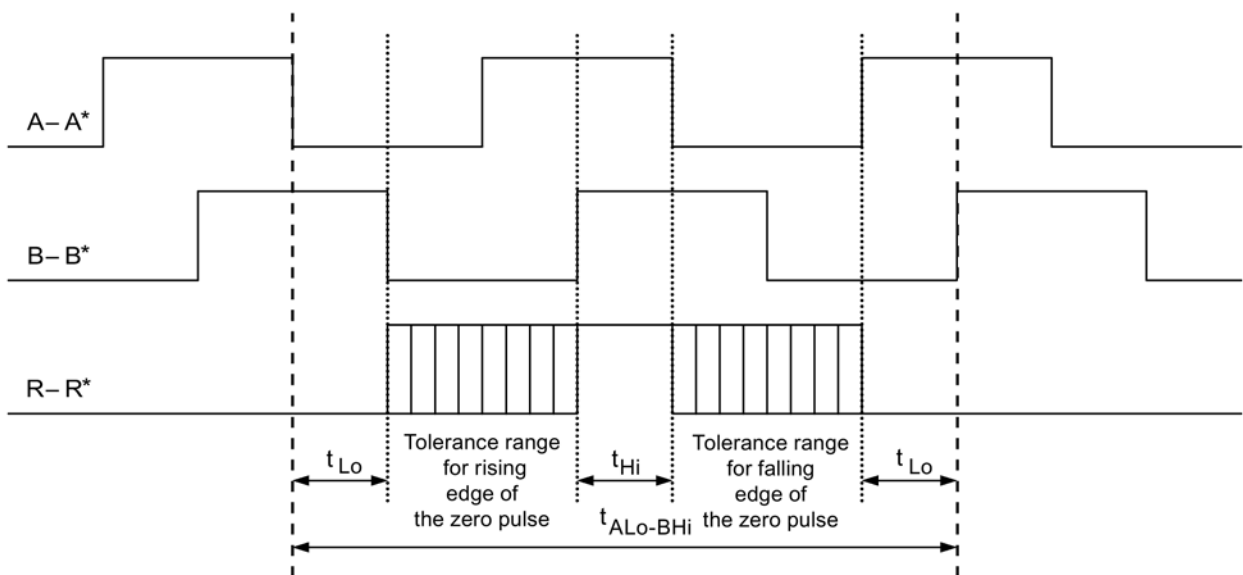
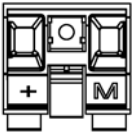

Figure 4-10 Position of the zero pulse to the track signals

4.3 Interface description

4.3.9 X224 24 V connector

Table 4- 16 X224 24 V connector

	Terminal	Designation	Technical data
	+	24 V power supply	Supply voltage: 24 V DC
	M	Ground	Electronics ground
			Type: Screw terminal 5 (Page 307) Max. connectable cross-section: 6 mm <sup>2</sup>
The 24 V connector is included in the scope of supply.			

## 4.4 Connection examples

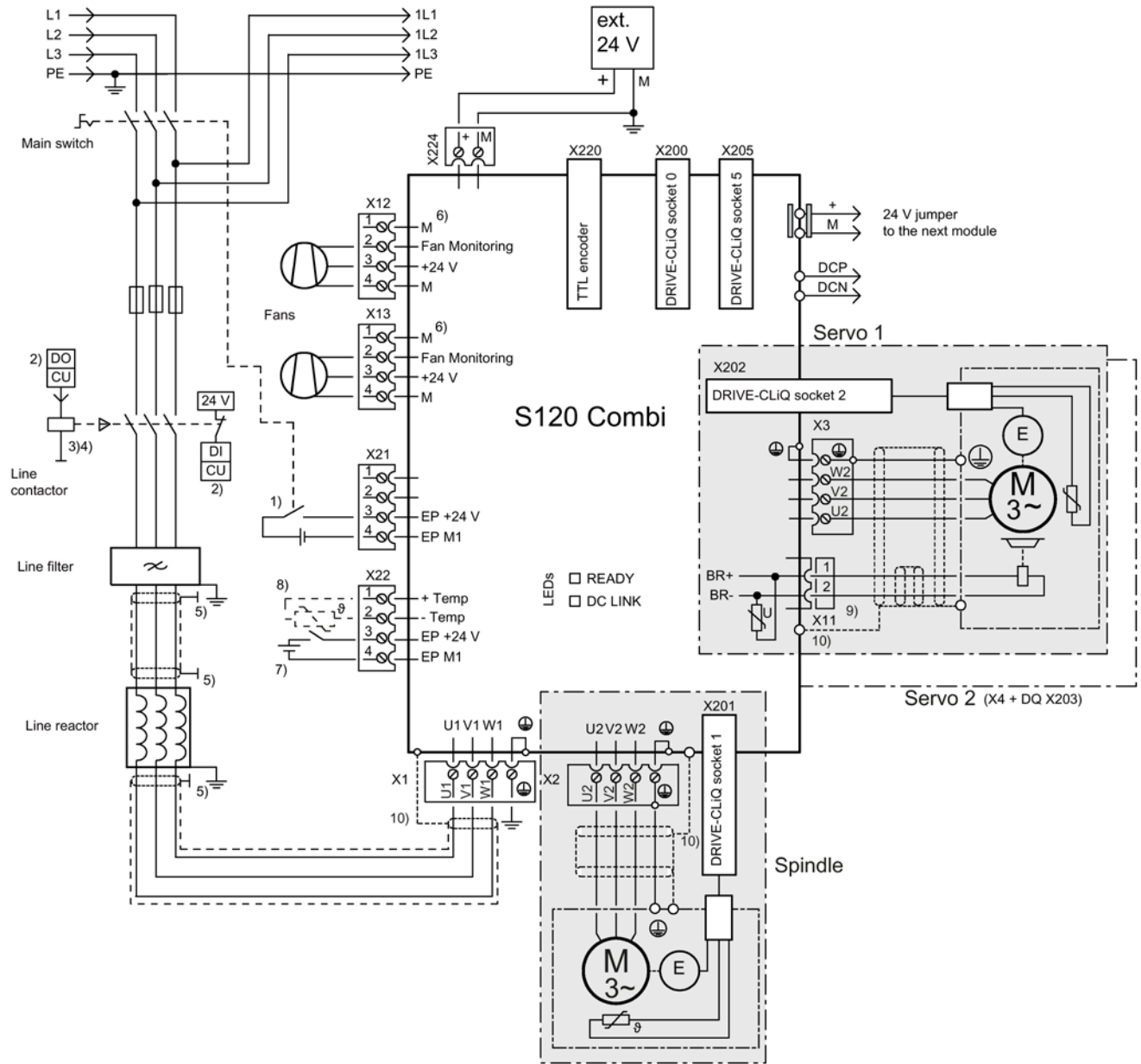

Figure 4-11 Connection example for an S120 Combi 3 axis Power Module with a motor holding brake

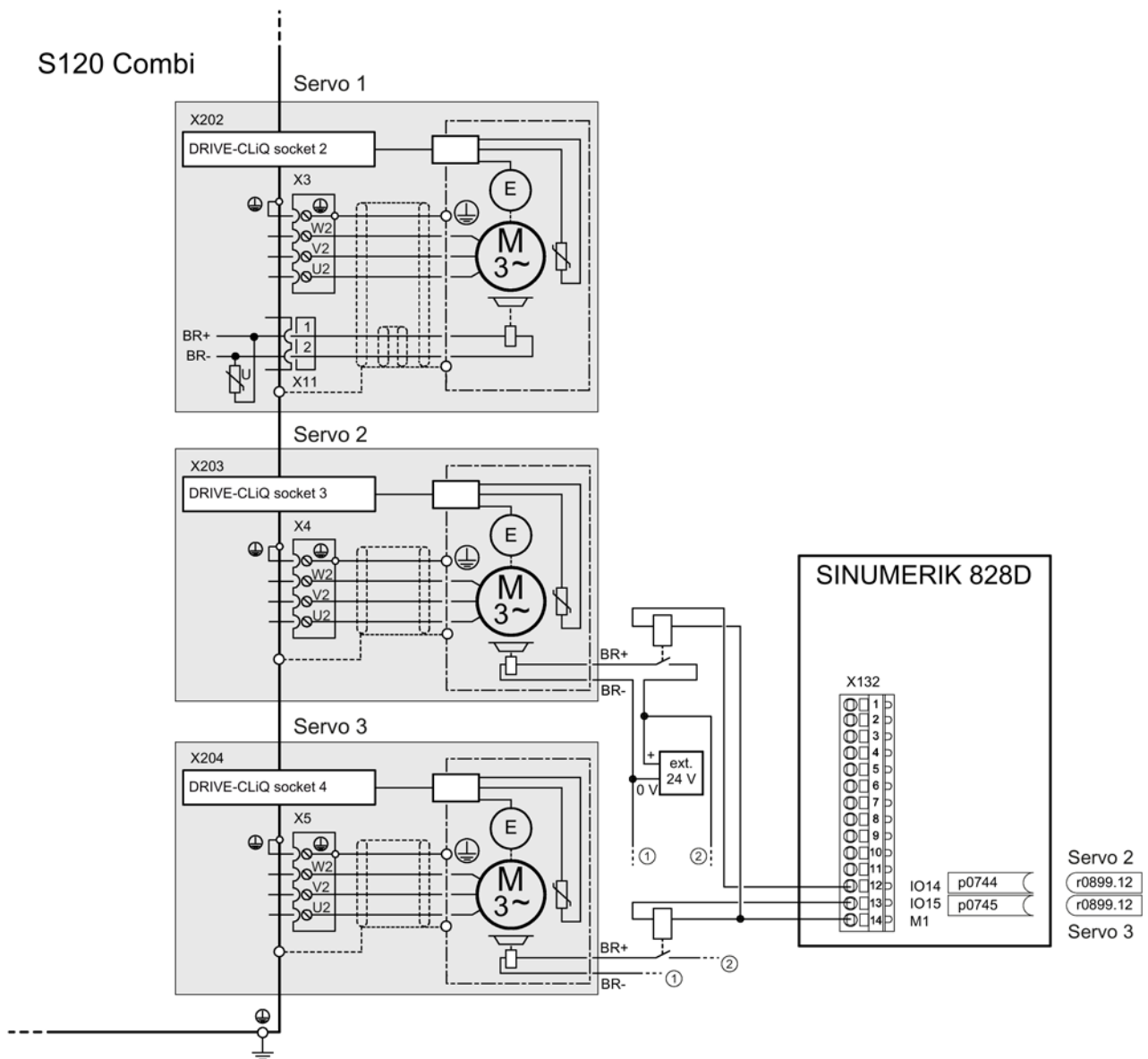

Figure 4-12 Connection example for an S120 Combi 4 axis Power Module with 3 motor holding brakes

**Motor holding brake for servo 1**

Brake control for servo 1 via internal brake interface (SBC possible)

**Motor holding brake for servo 2 and servo 3 (parameterizable in the expert list)**

- Settings in the Expert list
  - Servo2-p1215=3 and Servo3-p1215=3  
(3: Motor holding brake as for the sequence control, connection via BICO, no SBC possible)
- BiCo connections from the sequence control to digital outputs on the Control Unit
  - BICO interconnection to "open servo holding brake"
    - BiCo in CU\_I-p0744: Servo2-r0899.12
    - BiCo in CU\_I-p0745: Servo3-r0899.12
  - Output definition in CU\_I
    - CU\_I-p0728.14 =1
    - CU\_I-p0728.15 =1

---

**Note**

The circuit shown above is only an example.

A wiring diagram of the digital inputs/outputs on the PPU can be found in the SINUMERIK 828D Manual PPU, Edition 03/2013.

---

## 4.5 Meaning of the LEDs on the S120 Combi

The SINAMICS S120 Combi has 2 LEDs to display the status. The LED statuses for the S120 Combi are described in the table below. The status display refers to the internal infeed, the spindle and the servo drives and the TTL encoder evaluation of the S120 Combi Power Module.

Table 4- 17 Meaning of the LEDs on the S120 Combi

Status	DC LINK	Description, cause	Remedy
<b>RDY</b>	<b>DC LINK</b>		
Off	Off	The electronics power supply is missing or outside the permissible tolerance range.	Connect/test the electronics power supply
Green	Off	The component is ready for operation. Cyclic DRIVE-CLiQ communication is taking place.	-
	Orange	The component is ready for operation. Cyclic DRIVE-CLiQ communication is taking place. The DC link voltage is present.	-
	Red	The component is ready for operation. Cyclic DRIVE-CLiQ communication is taking place. The DC link voltage is too high.	Check the line supply voltage.
Orange	Orange	DRIVE-CLiQ communication is being established.	-
Red	-	This component has at least one fault. <b>Note:</b> The LED is activated regardless of whether the corresponding messages have been reconfigured.	Remedy and acknowledge fault
Green/Red (0.5 Hz)	-	Firmware is being downloaded.	
Green/Red (2 Hz)	-	Firmware has been downloaded. Wait for POWER ON.	Carry out a POWER ON
Green / Orange or Red / Orange	-	Component recognition via LED is activated. This function can be parameterized (see SINAMICS S120/S150 List Manual) <b>Note:</b> Both possibilities depend on the status of the LED when activating.	-



**! WARNING**

**Danger to life through electric shock due to applied DC link voltage**

Irrespective of the state of the LED "DC LINK", hazardous DC-link voltages can always be present.

Death or serious injury can result when live parts are touched.

- Observe the warning information on the component.



### Cause and rectification of faults

The following reference material contains information about the cause of faults and how they are rectified:

SINAMICS S120 Function Manual Drive Functions (FH1)

SINUMERIK 828D Turning and Milling Commissioning Manual

SINUMERIK 840D sl commissioning CNC

## 4.6 Dimension drawings

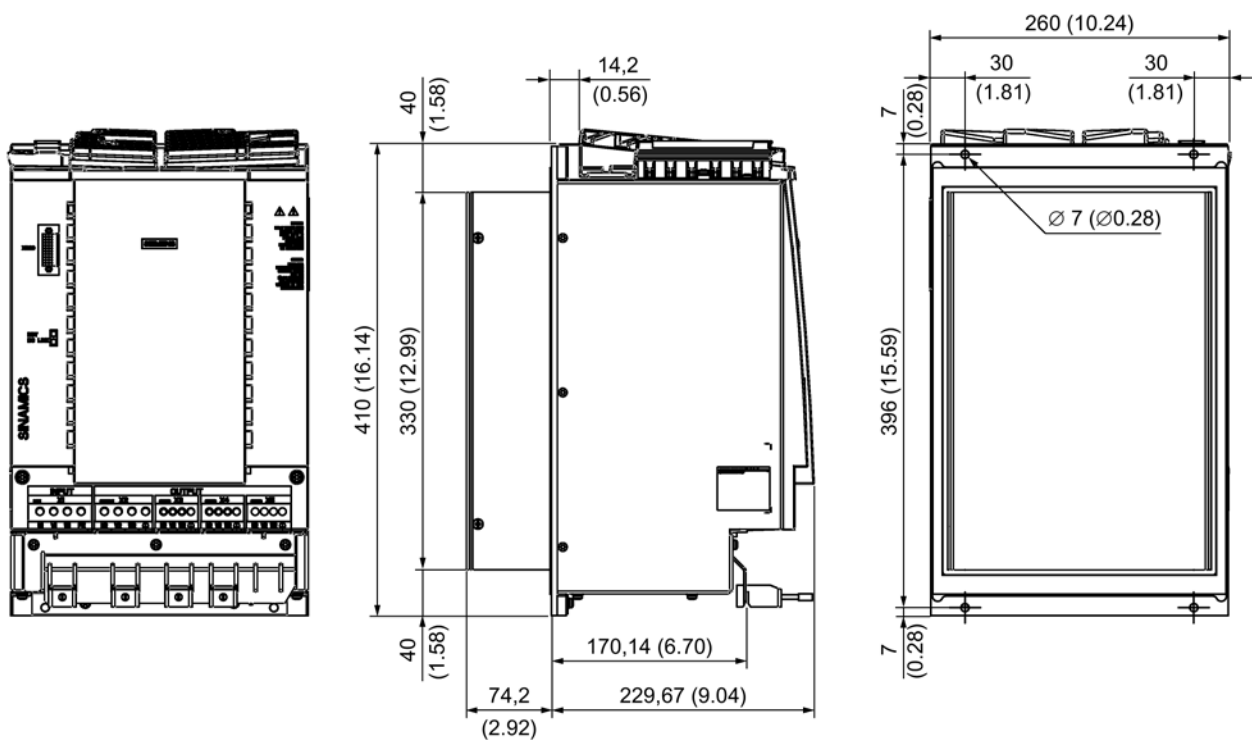

Figure 4-13 Dimension drawing of the S120 Combi 3 axes Power Module, all dimensions in mm and (inches)

4.6 Dimension drawings

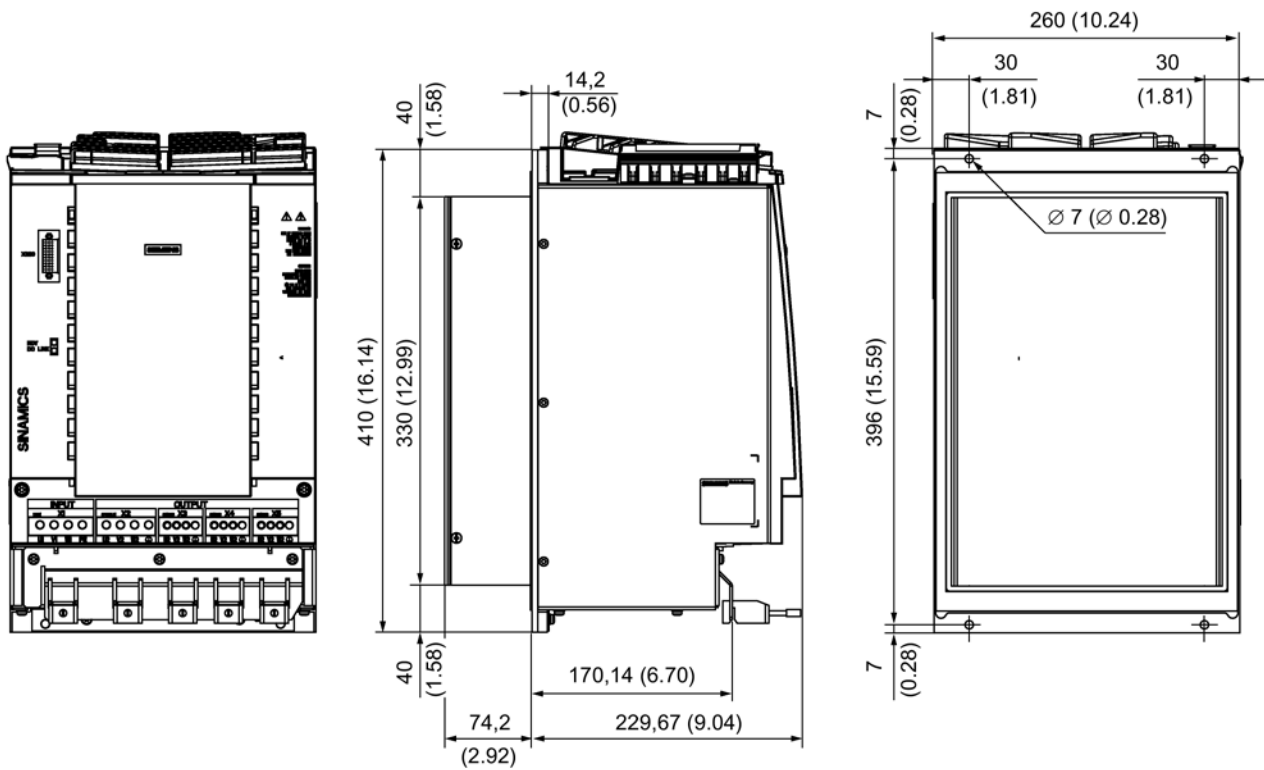

Figure 4-14 Dimension drawing of the S120 Combi 4 axes Power Module, all dimensions in mm and (inches)

## 4.7 Installation

### 4.7.1 Drilling patterns and installation cut-outs

#### Preparing the mounting panel

The installation cut-outs shown below are for any S120 Combi Power Module and the external fan unit.

The drilling patterns differ by the number and width of the expansion axes. Select the appropriate drilling pattern corresponding to your individual design.

4.7 Installation

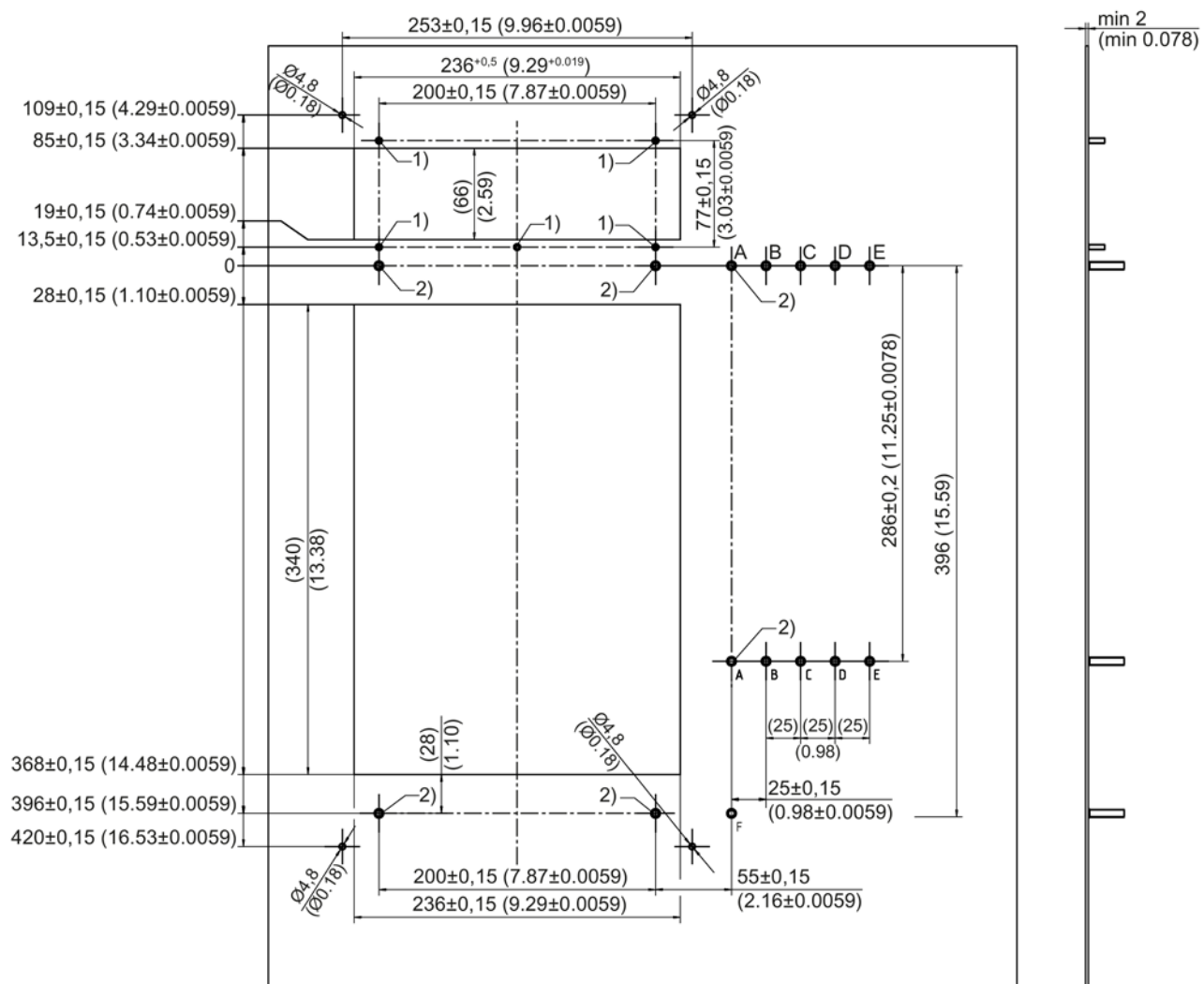

	A-A	B-B	C-C	D-D	E-E	A-F
Combi	-	-	-	-	-	-
Combi + 50 mm	x	-	-	-	-	x
Combi + 50 mm + 50 mm	x	-	x	-	-	-
Combi + 75 mm	x	x	-	-	-	-
Combi + 75 mm + 50 mm	x	x	-	x	-	-
Combi + 75 mm + 75 mm	x	x	-	x	x	-

- 1) Self-clinching studs M4
- 2) Self-clinching studs M6
- All non-dimensioned chamfers, 2 x 45°

Figure 4-15 Dimensions for the installation cut-outs and drilling patterns for an S120 Combi Power Module with external fan unit, reinforcement plates and expansion axes, all dimensions in mm and (inches)

## 4.7.2 Installing the reinforcement plates

### 4.7.2.1 Description

The reinforcement plates for the S120 Combi fulfill the following functions:

- Air is routed in a specific way to dissipate the heat of the external heat sink
- They stabilize the mounting panel

The reinforcement plates must always be mounted. They should be installed at the rear of the mounting panel or the control cabinet **before** installing the S120 Combi Power Module and the external fan unit.

---

#### Note

The reinforcement plates are not included in the scope of delivery of the S120 Combi. They must be separately ordered (Article number: 6SL3161-1LP00-0AA0).

---

### 4.7.2.2 Installation

The reinforcement plates for the S120 Combi must be mounted in each case. For mounting, holes that correspond to the drilling pattern below must be drilled in the mounting panel.

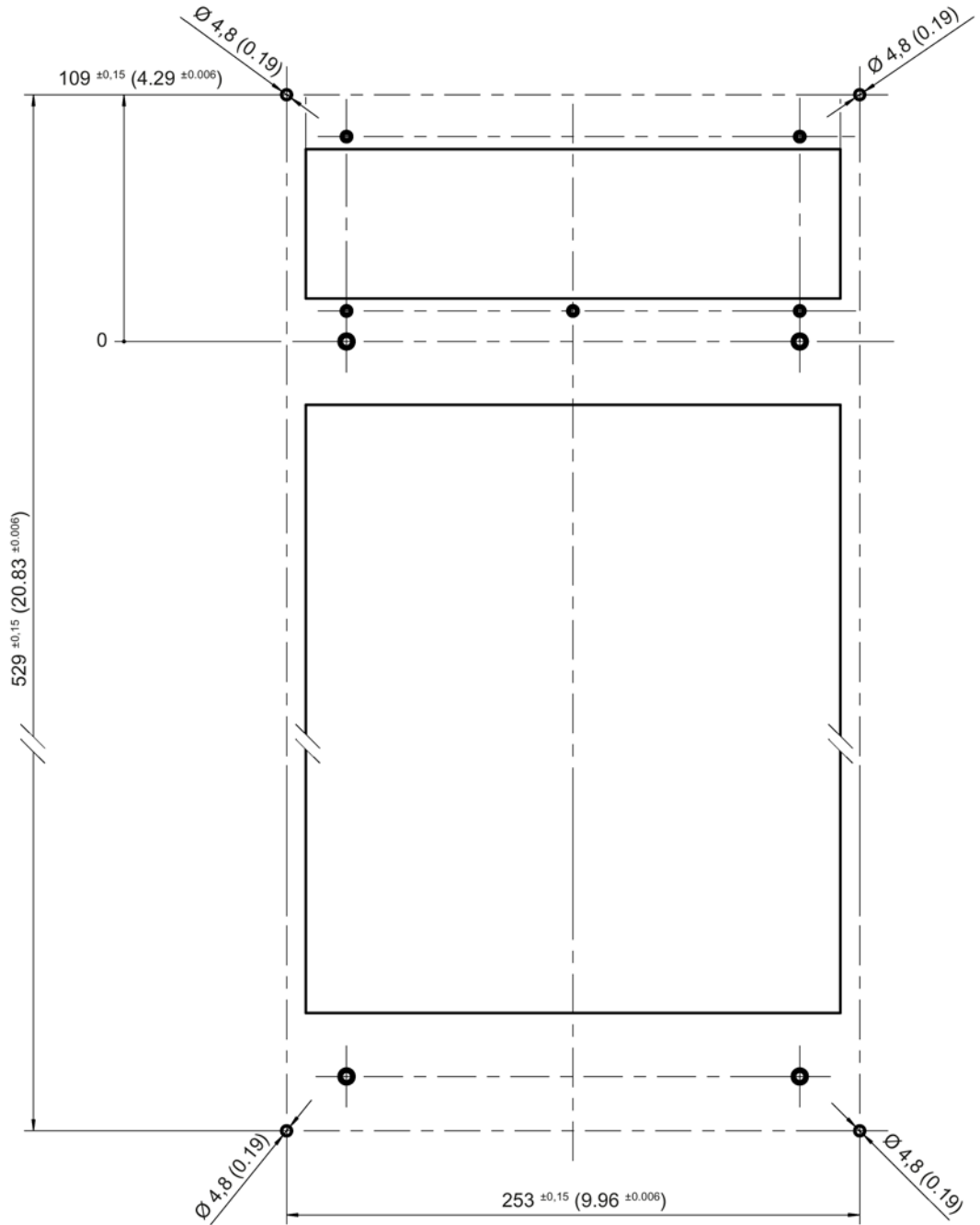

Figure 4-16 Drilling pattern for mounting the reinforcement plates

**Holes:**  
4 X Ø 4.8 mm

**Screws to be used:**

M4 x 10 (ISO 7045 (DIN 7965), ISO 7380, DIN EN ISO 1207, ISO 1580M4)

**Tightening torques:**

Initially tighten by hand (0.5 Nm), then tighten with 1.8 Nm

**Installing the reinforcement plates**



Insert the left reinforcement plate into the mounting cut-out.



Locate the reinforcement plate on the mounting panel.



Screw the reinforcement plate at the top and bottom.



Insert the right reinforcement plate into the mounting cut-out.

4.7 Installation



Locate the reinforcement plate on the mounting panel.



Screw the reinforcement plate at the top and bottom.

When installing the reinforcement plates, it is important to observe alignment.

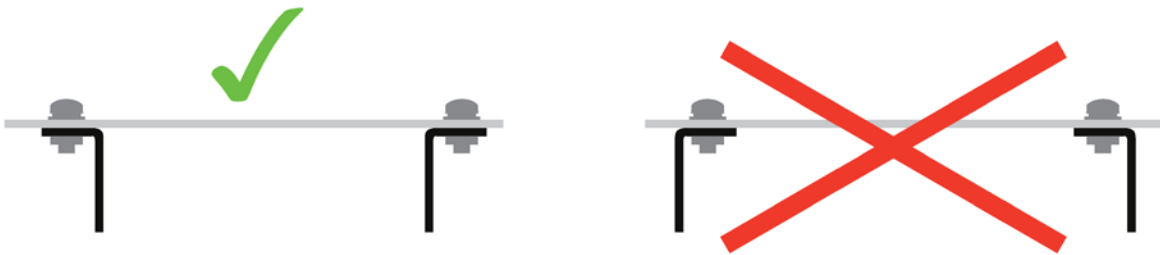
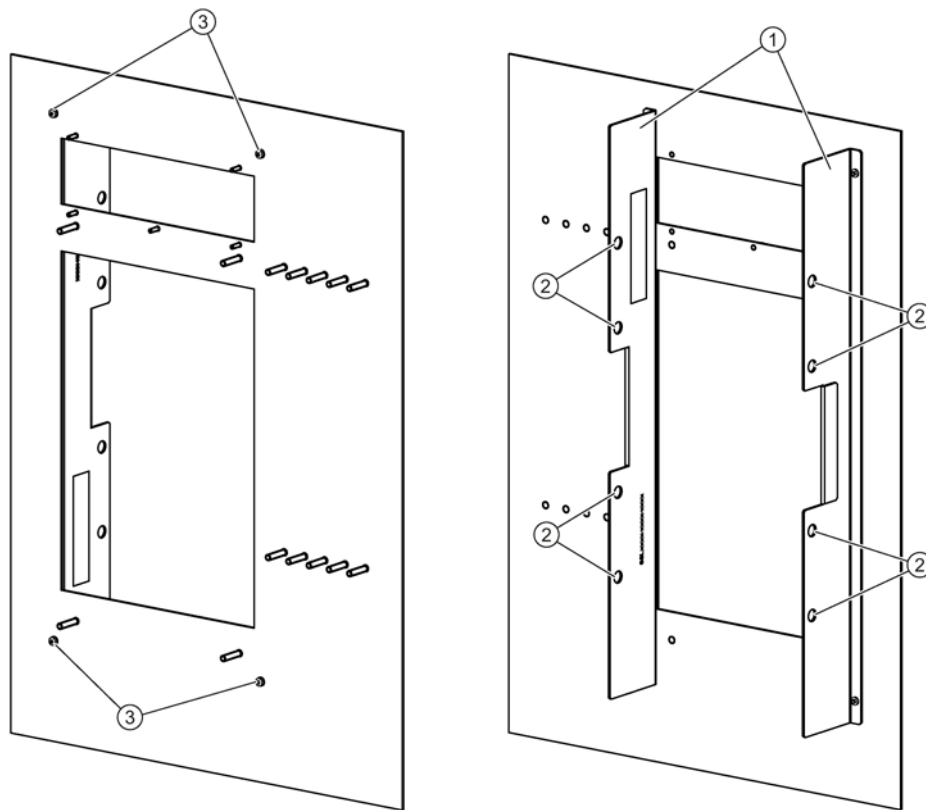

Figure 4-17 Alignment of the reinforcement plates





- ① Reinforcement plates
- ② Holes to remove/tighten the screws on the air baffle plate of the S120 Combi
- ③ M4x10 screws

Figure 4-18 Installed reinforcement plates: View from the front and from the rear

**CAUTION**

**Physical injury due to incorrect mounting of the reinforcement plates**

If the reinforcing plates are incorrectly mounted, this can result in an excessively high heat sink temperature and cause the S120 Combi Power Module to prematurely trip.

Contact with hot parts may cause you to suffer a burn injury.

- Follow the installation instructions when mounting the reinforcement plates.

### 4.7.2.3 Technical data

6SL3161-1LP00-0AA0	Unit	Value
Weight (2 units)	kg	1.5
Dimensions (W x H x D)	mm	150 x 57.5 x 750

### 4.7.3 Installing an S120 Combi Power Module

#### Installation steps

1. Mount the self-clinching flush head studs M6.
2. Install the S120 Combi Power Module.
3. Firstly tighten the M6 nuts by hand (0.5 Nm).
4. Tighten the nuts in the specified sequence (1 to 4) with 10 Nm.

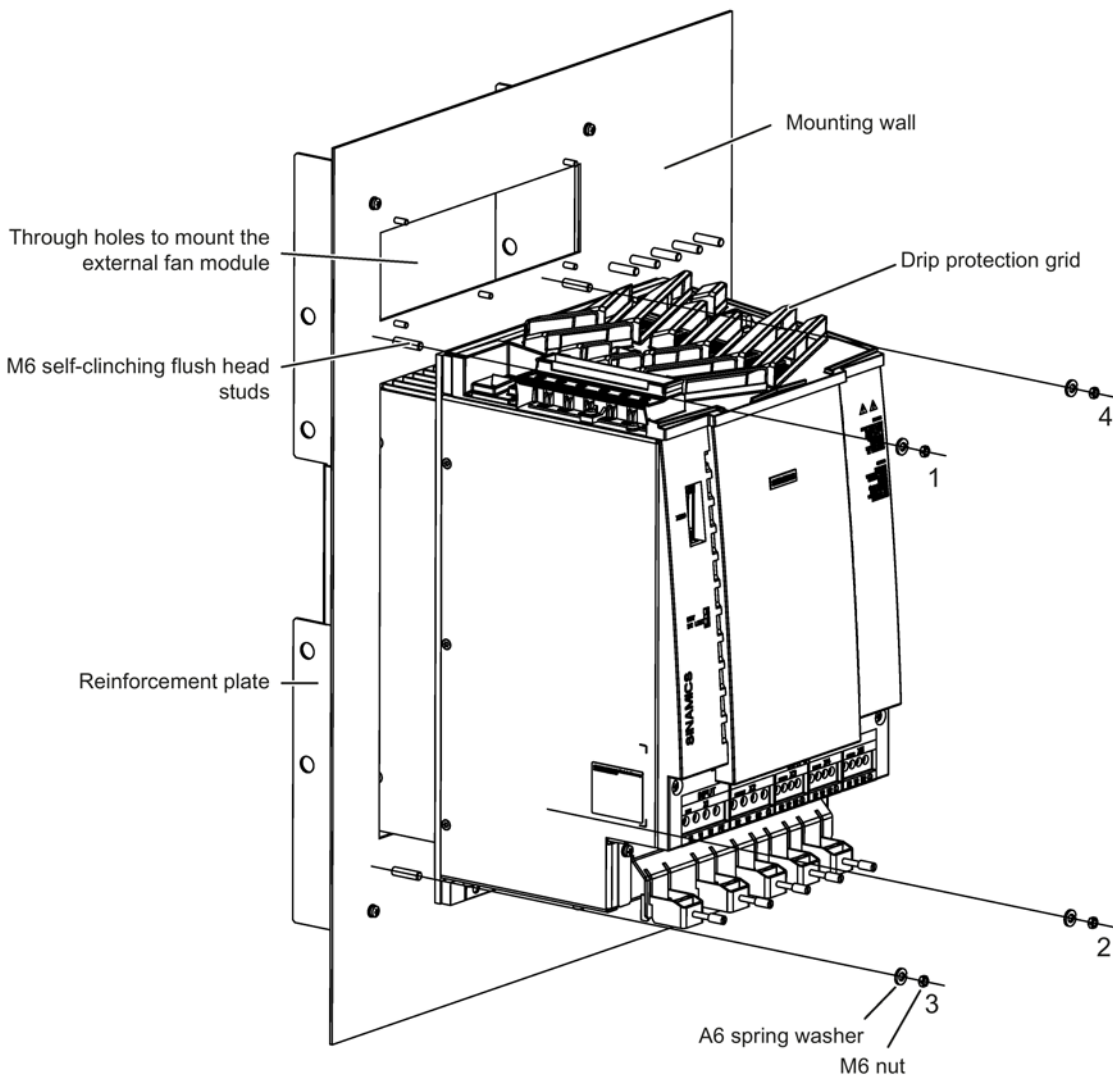

Figure 4-19 Installing an S120 Combi Power Module

#### 4.7.4 Assembling a drip protection grid

Drip protection grid 6SL3161-3DP00-0AA0 can be mounted on S120 Combi Power Modules in order to prevent liquids from dripping into the module.

For the S120 Combi Power Module 6SL3111-4VE21-0EA0 the drip protection grid is provided with the unit when shipped from the factory. For all other S120 Combi Power Modules, it can be ordered as replacement part and retrofitted.

The drip protection grid is directly attached to the S120 Combi Power Modules.

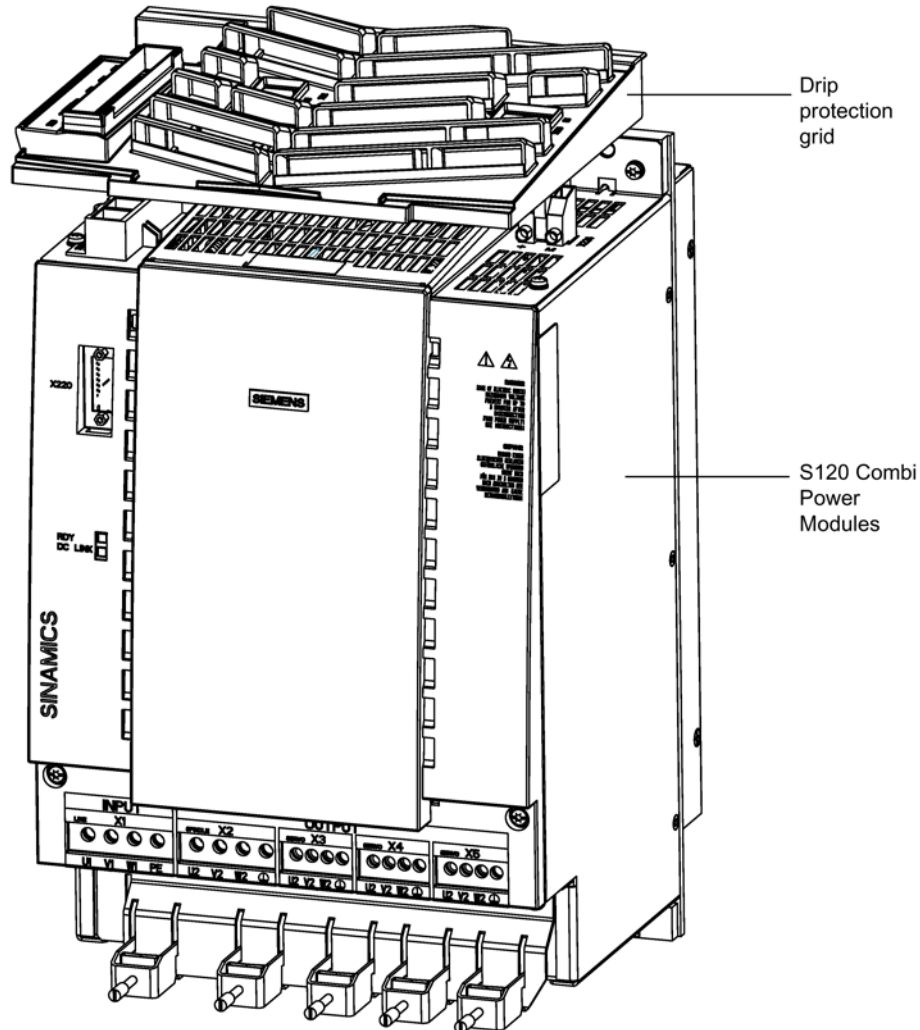

Figure 4-20 S120 Combi Power Modules with drip protection grid

## 4.7.5 Mounting an external fan module

### 4.7.5.1 Description

The S120 Combi provides an integrated fan control and supply for an external 24 V fan unit. The fan unit is connected via interface X12/X13. The outputs are designed for a maximum total current of 2 A and are short-circuit and ground-fault proof.

The following functions are available when using the external fan unit:

- Operating hours counter (see SINAMICS S120/S150 List Manual)
- Setting the maximum operating time (see SINAMICS S120/S150 List Manual)
- Evaluating fault signals

### 4.7.5.2 Overview

The external fan unit comprises the following components:

- Fan cradle with seal for installation in the control cabinet
- Connection cables with 4-pin connector
- Double fan
- Fan support plate
- Air baffle plate

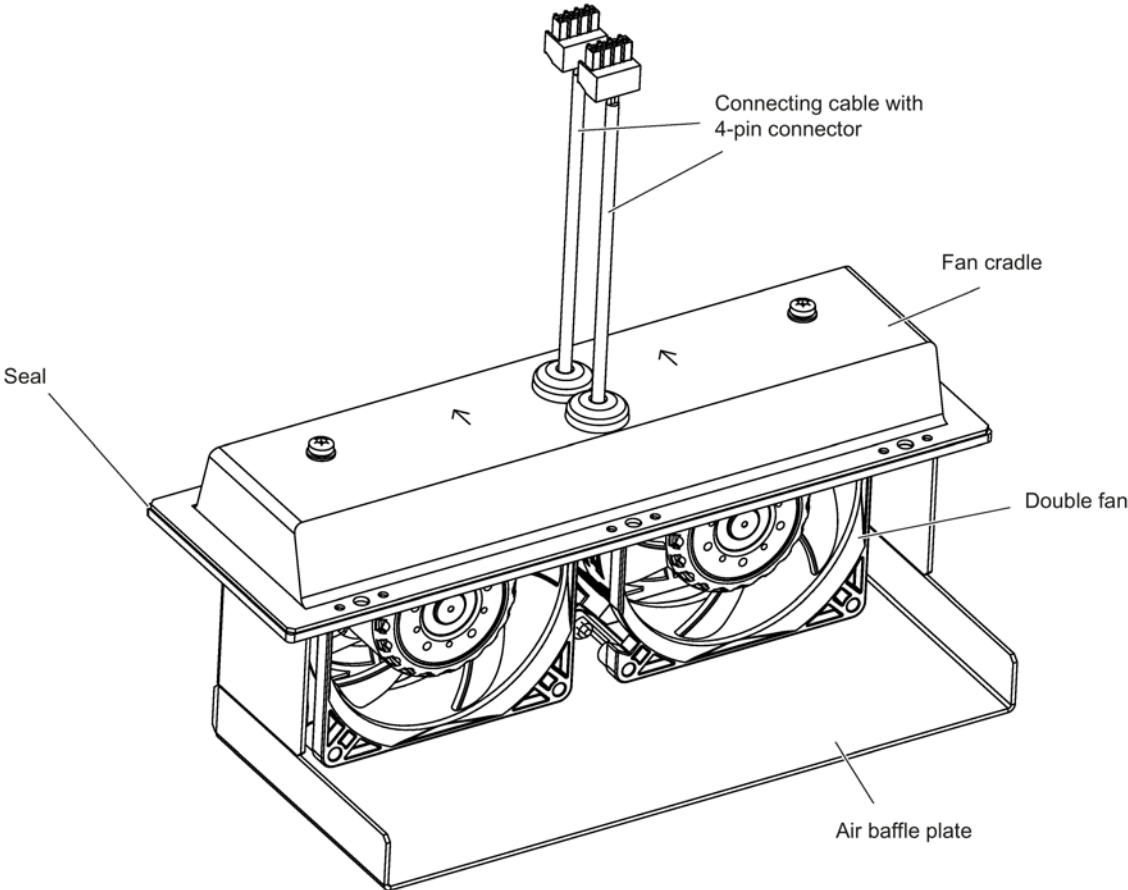

Figure 4-21 External fan unit

When a fan fails, the complete external fan unit must be replaced.

4.7.5.3 Dimension drawing

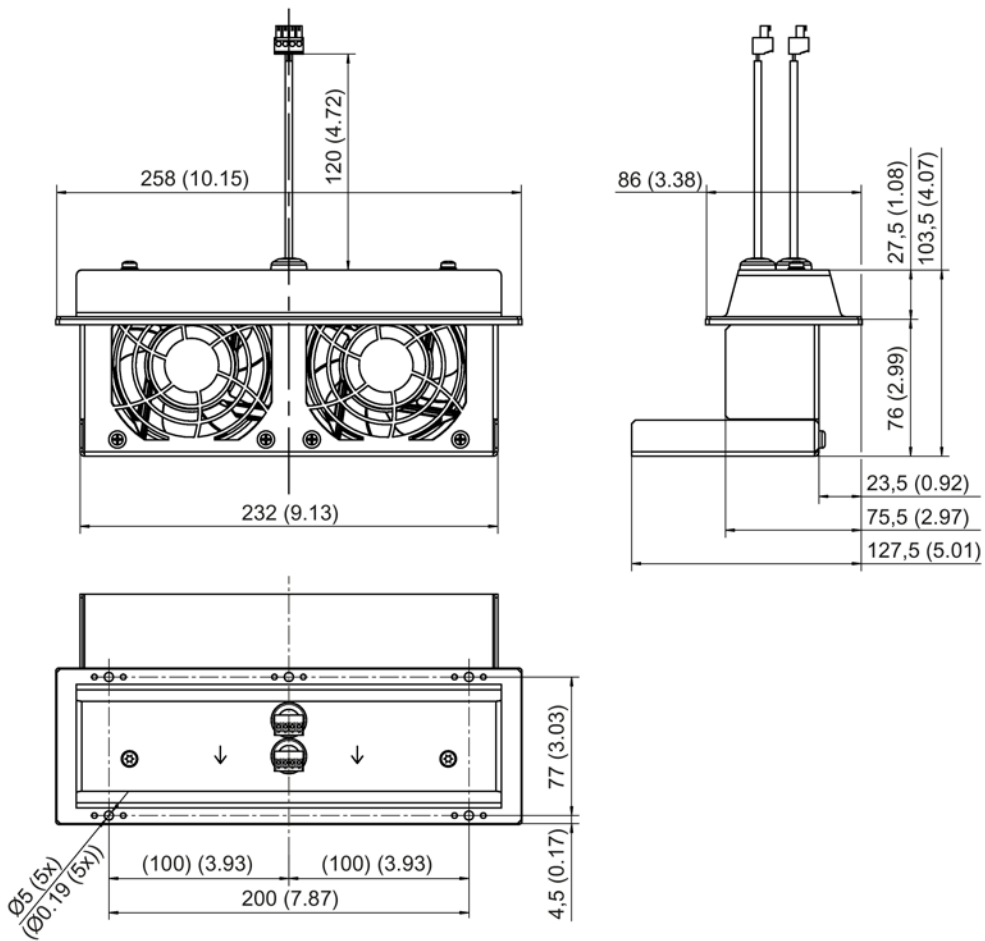

Figure 4-22 Dimension drawing of the external fan unit, all dimensions in mm and (inches)

### 4.7.5.4 Installation

#### Preparation

The external fan unit is always installed above the S120 Combi in the control cabinet.

Make an installation cut-out in the control cabinet panel. The position is dependent on the installation cut-out for the S120 Combi Power Module.

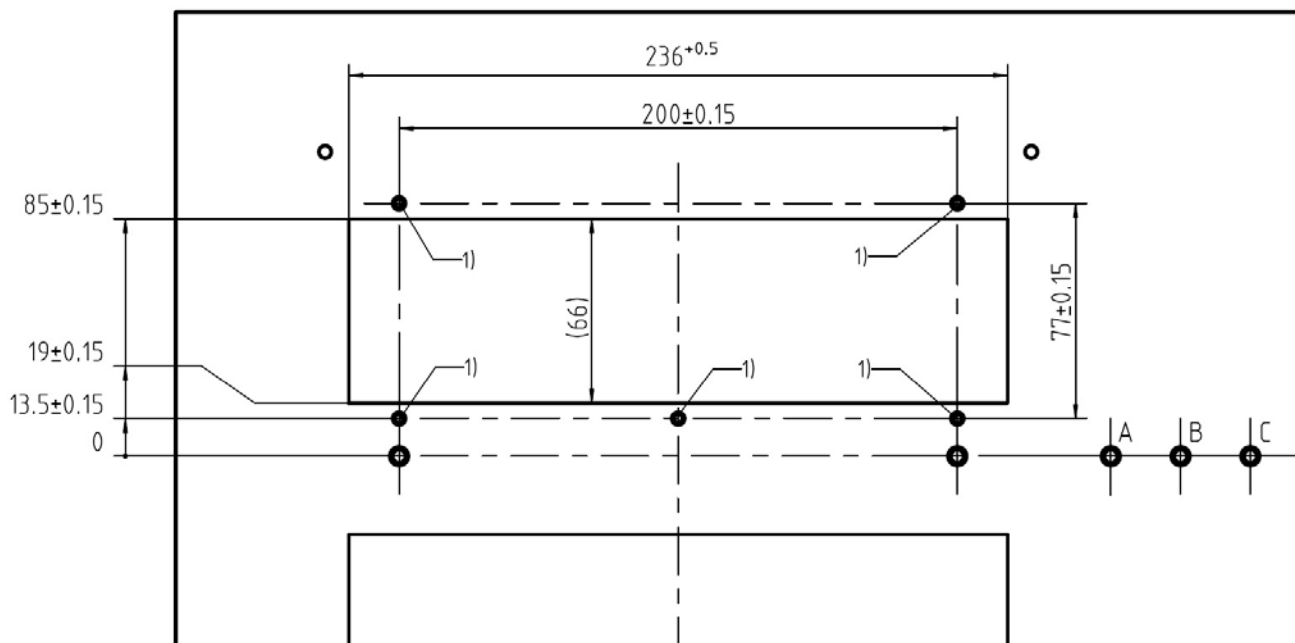

Figure 4-23 Cut-out from the drilling pattern and installation cut-out S120 Combi for the external fan unit

The zero line shown above runs at the height of the upper bolts used to mount the S120 Combi Power Module.

#### Installation

1. Mount the self-clinching flush head studs - position 1) in the diagram above.
2. Mount the fan unit as shown below.
3. Connect the power supply cables of the fan unit to the S120 Combi Power Module.
  - Cable A to terminal X12
  - Cable B to terminal X13

4.7 Installation

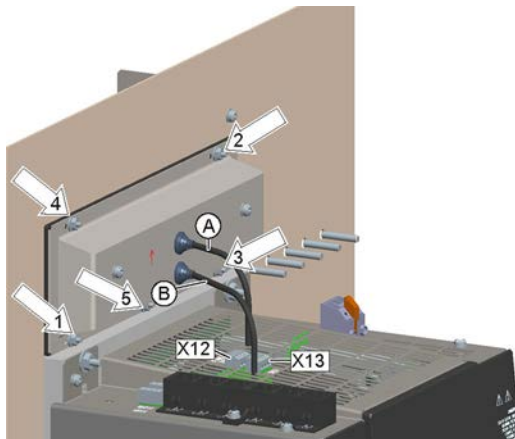
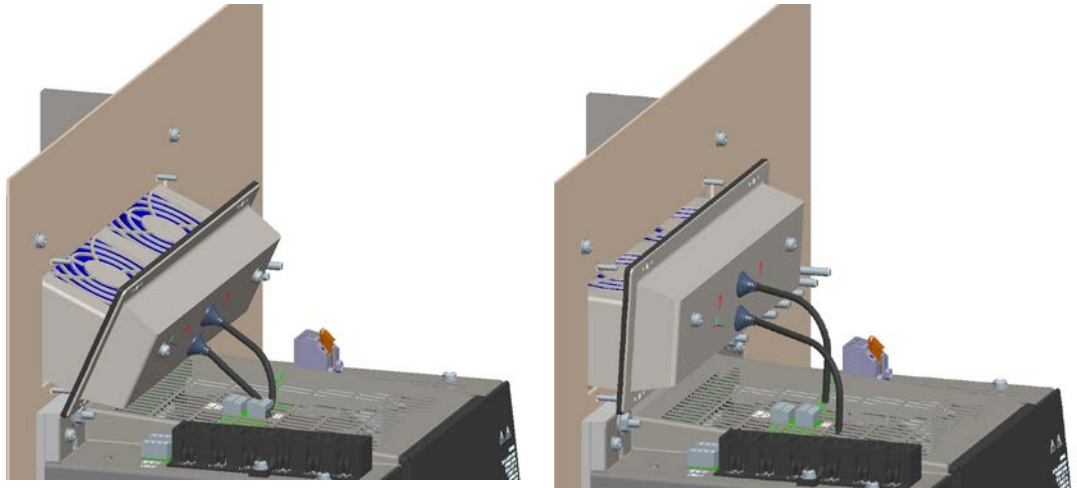
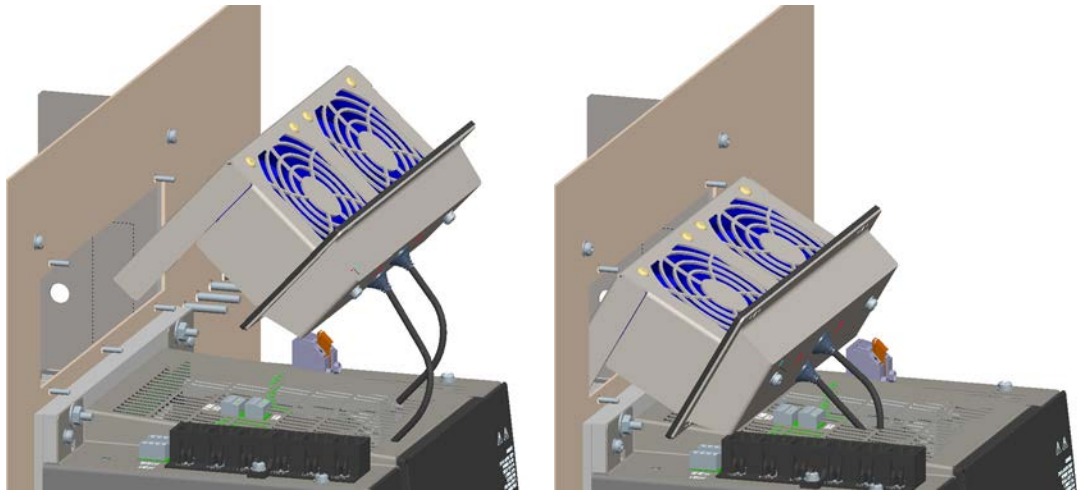

Firstly, tighten the nuts by hand with 0.5 Nm. Subsequently, tighten the nuts in the specified mounting sequence 1 to 5 with a tightening torque of 1.8 Nm.



Table 4- 18 Mounting accessories

Number	Designation	Specification
5	Self-clinching flush head studs	M4, steel, strength class 8.8, zinc-plated, length: 15 mm
5	Nut	M4, steel, strength class 8, zinc-plated

The reinforcement plates must always be installed when operating the S120 Combi with the external fan unit.

 **CAUTION**

**Physical injury during operation without reinforcement plates**

Operating without the reinforcement plates can result in an excessively high heat sink temperature and cause the S120 Combi Power Module to prematurely trip.

Contact with hot parts may cause you to suffer a burn injury.

- Only operate the S120 Combi with reinforcement plates.



**WRONG:** S120 Combi and external fan unit without reinforcement plates



**CORRECT:** S120 Combi and external fan unit with installed reinforcement plates

### 4.7.5.5 Technical data

Table 4- 19 Technical data of the external fan unit

6SL3161-0EP00-0AA0	Unit	Value
Input voltage	V <sub>DC</sub>	20.4 ... 28.8
Power consumption	W	18
Electronics current drawn at 24 V DC	A	0.8
Volumetric rate of air flow	m <sup>3</sup> /h	290
Service life	h	50000 at 55 °C
Dimensions (W x H x D)	mm	258 x 104 x 86
Weight	kg	1.5
Degree of protection		IP54

## 4.8 Electrical connection

### 4.8.1 Stripped length for the line supply and power cables

Non-prefabricated MOTION-CONNECT power cables must be appropriately prepared before being connected to the S120 Combi.

---

#### Note

#### Special issue for UL applications

For UL applications, use 60/75 °C copper wires/conductors.

---

#### Cables without connection cables for the motor holding brake

1. Cut the cable jacket to dimension A from the table below
2. Strip the single cores U, V, W and PE and crimp on end sleeves with insulation support

#### Cables with connection cables for the motor holding brake

1. Cut the cable jacket to 250 ± 5 mm
2. Cut the single cores U, V, W and PE to dimension A from the table below, strip and crimp on end sleeves with insulation support
3. Strip the connection cables for the motor holding brake and screw to the brake connector



**! WARNING**

**Danger to life through electric shock due to non-isolated end sleeves**

Death or serious injury can occur if end sleeves are used that do not comply with the specified requirements.

- In this case, use shrink tubing.

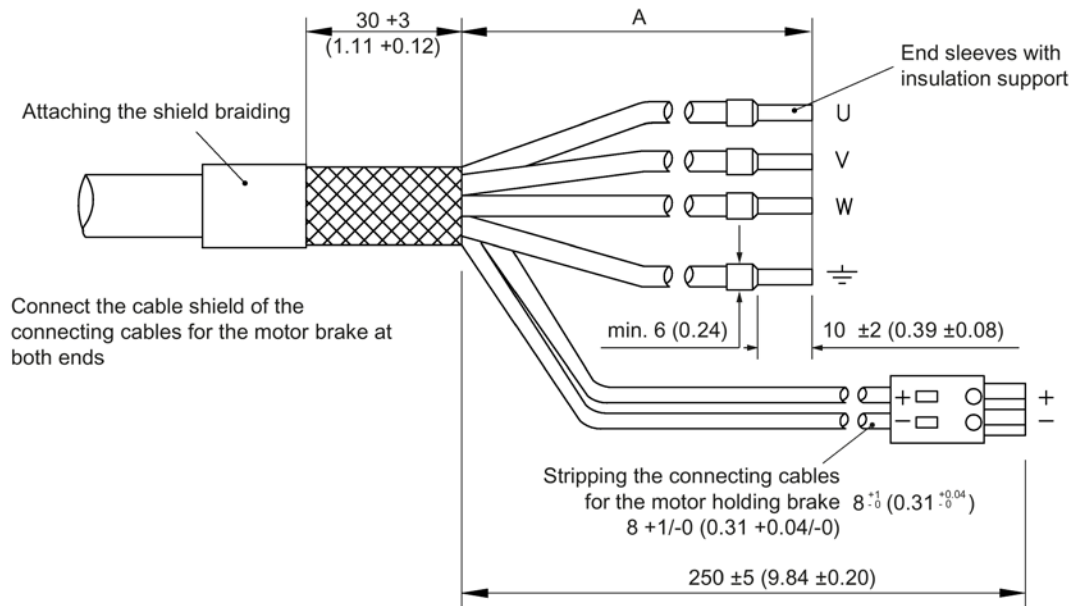
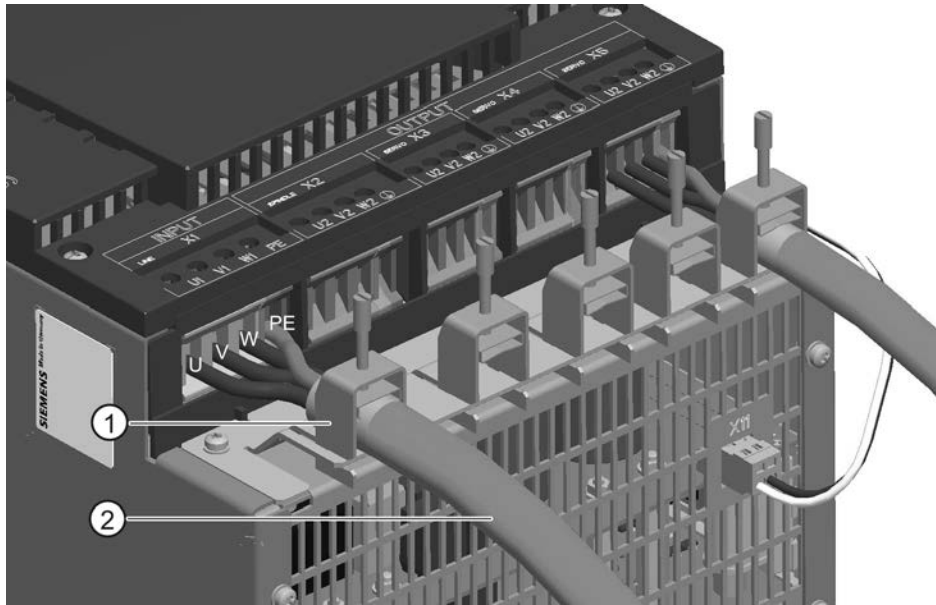

Figure 4-24 Stripped lengths for power cables

Cable cross-section in mm <sup>2</sup>	A in mm and (inches)
4 x 1.5	55 +3 (2.17 +0.12)
4 x 2.5	55 +3 (2.17 +0.12)
4 x 4	55 +3 (2.17 +0.12)
4 x 6	55 +2 (2.17 +0.08)
4 x 10	55 +2 (2.17 +0.08)

### 4.8.2 Line supply cable

Shielded MOTION-CONNECT 500 and 800 line supply cables are recommended in order to maintain the EMC limit values. The line supply cable is connected at interface X1 (INPUT). The single cores of the cable are labeled with U, V, W and PE. Cables are connected at the S120 Combi corresponding to the terminal labeling. The cable shield should be connected and fixed using the shield clamp.



- ① Shield connection clamp
- ② Line supply cable

Figure 4-25 Line supply cable connected at the S120 Combi

#### NOTICE

##### Damage when strain relief is not used

The shield clamp does not provide strain relief. In the event that strain relief of the power cable is not carried out separately using appropriate measures, the shield connection clamp may be damaged.

- Install additional strain relief for the power cable.

#### NOTICE

##### Damage to unshielded power cables due to shield connection clamps

When using unshielded power cables, the unshielded individual cores can be damaged by the shield connection clamp.

- Only use the shield connection clamp for shielded power cables.

### 4.8.3 Power cables for motors

The motor power cables are connected at interfaces X2 to X5. The single cores of the cable are labeled with U, V, W and PE. The cables are connected corresponding to the terminal labels at the S120 Combi.

When using a power cable with connection cables for the motor holding brake, the cores for the motor holding brake are connected at interface X11 (see the diagram below). In this case, connect the cable shield of all cable cores. Fix the cable shield using the shield clamp.

When using a separate cable for the motor holding brake, its cable shield should be connected to the associated shield support of the motor power cable.

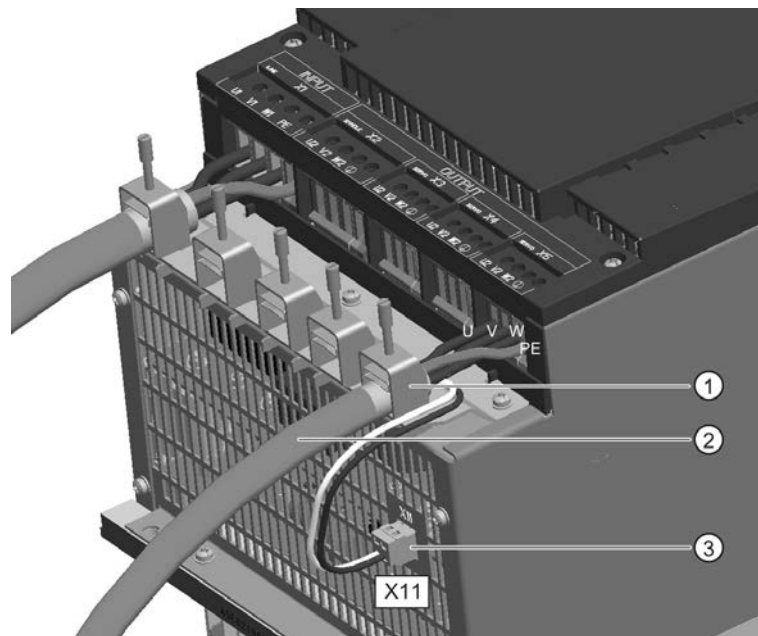

- ① Shield connection clamp
- ② Power cables with connection cables for the motor holding brake
- ③ Connector for the motor holding brake

Figure 4-26 Power cable connected at the S120 Combi

#### NOTICE

##### Damage when strain relief is not used

The shield clamp does not provide strain relief. In the event that strain relief of the power cable is not carried out separately using appropriate measures, the shield connection clamp may be damaged.

- Install additional strain relief for the power cable.

#### 4.8.4 Signal cables at the EP terminals

The shields of the signal cables connected to the EP terminals X21 and X22 are connected using the shield clamp ① from the accessories pack (Weidmüller: KLBÜ 4-13.5). The connection involves the following steps:

- Secure the shield connection clamp on the S120 Combi. Use an SW3 wrench with 1.8 Nm tightening torque.
- Remove the insulation from the signal cables and crimp the individual cores with end sleeves.
- Connect the cable cores to the EP terminals (screw terminals).
- Connect the cable shields as shown below.

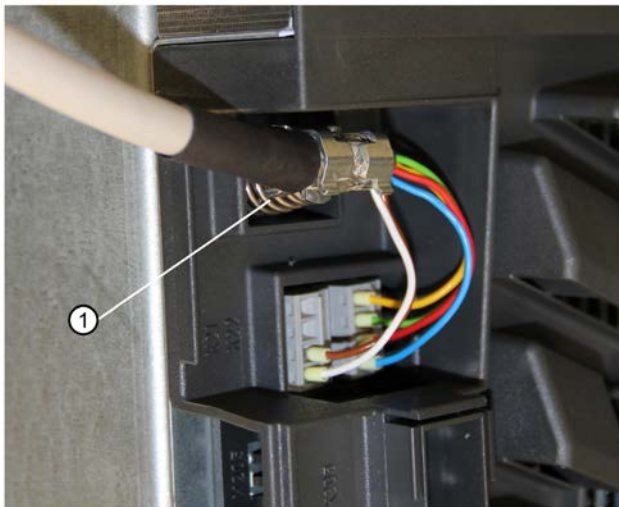

Figure 4-27 Signal cables connected with the correct shield support

## 4.9 Technical data

Table 4- 20 Technical data of the S120 Combi 3 axes Power Modules

3 axes Power Modules	6SL3111 -	3VE21-6FA0	3VE21-6EA0	3VE22-0HA0
		16 kW / 18 A / 5 A / 5 A	16 kW / 24 A / 9 A / 9 A	20 kW / 30 A / 9 A / 9 A
<b>Infeed</b>				
<b>Infeed</b> Rated power (S1) <sup>1)</sup> Infeed power for S6 duty P <sub>S6</sub> (40 %) <sup>1)</sup> Peak infeed power <sup>1)</sup>	kW (P <sub>n</sub> ) kW (P <sub>S6</sub> ) kW (P <sub>max</sub> )	16 21 35	16 21 35	20 26.5 40
<b>Regenerative feedback</b> Rated power (S1) Peak regenerative power	kW (P <sub>n</sub> ) kW (P <sub>max</sub> )	16 35	16 35	20 40
<b>Supply voltages</b> Line voltage Line frequency Electronics power supply	V <sub>AC</sub> Hz V <sub>DC</sub>	3 AC 380 – 10 % ... 3 AC 480 + 10 % 45 ... 66 24 (20.4 ... 28.8)		
<b>Rated input current</b> at 400 V AC at 380 V AC / 480 V AC at 400 V; for S6 duty I <sub>S6</sub> (40 %) at 400 V AC peak current	A <sub>AC</sub> A <sub>AC</sub> A <sub>AC</sub> A <sub>AC</sub>	28 29 / 25 35.5 56	28 29 / 25 35.5 56	34 35 / 30 44 63.5
<b>Spindle</b>				
<b>Output current</b> Rated current (I <sub>n</sub> ) Base-load current (I <sub>H</sub> ) Intermittent duty current for S6 duty I <sub>S6</sub> (40%) Peak current (I <sub>max</sub> )	A <sub>ACrms</sub> A <sub>ACrms</sub> A <sub>ACrms</sub> A <sub>ACrms</sub>	18 15.3 24 36	24 20.4 32 48	30 25.5 40 56
<b>Rated power</b> at 540 V DC link voltage at 600 V DC link voltage	kW kW	8.7 9.7	11.7 13	14.4 16
<b>Pulse frequency spindle</b>	kHZ	4	4	4
<b>Output voltage</b>	V <sub>ACrms</sub>	0 ... 0.7 x DC link voltage		
<b>Feedrate 1</b>				
<b>Output current</b> Rated current (I <sub>n</sub> ) Base-load current (I <sub>H</sub> ) Intermittent duty current for S6 duty I <sub>S6</sub> (40%) Peak current (I <sub>max</sub> )	A <sub>ACrms</sub> A <sub>ACrms</sub> A <sub>ACrms</sub> A <sub>ACrms</sub>	5 4.3 6.5 10	9 7.7 12 18	9 7.7 12 18
<b>Rated power</b> at 540 V DC link voltage at 600 V DC link voltage	kW kW	2.4 2.7	4.3 4.8	4.3 4.8
<b>Pulse frequency feedrate 1</b>	kHZ	4	4	4
<b>Output voltage</b>	V <sub>ACrms</sub>	0 ... 0.7 x DC link voltage		
<b>Feedrate 2</b>				

## 4.9 Technical data

3 axes Power Modules	6SL3111	3VE21-6FA0	3VE21-6EA0	3VE22-0HA0
	-			
<b>Output current</b>				
Rated current ( $I_n$ )	$A_{ACrms}$	<b>5</b>	<b>9</b>	<b>9</b>
Base-load current ( $I_H$ )	$A_{ACrms}$	4.3	7.7	7.7
Intermittent duty current for S6 duty $I_{S6}$ (40%)	$A_{ACrms}$	6.5	12	12
Peak current ( $I_{max}$ )	$A_{ACrms}$	10	18	18
<b>Rated power</b>				
at 540 V DC link voltage	kW	2.4	4.3	4.3
at 600 V DC link voltage	kW	2.7	4.8	4.8
<b>Pulse frequency feedrate 2</b>	kHz	4	4	4
<b>Output voltage</b>	$V_{ACrms}$	0 ... 0.7 x DC link voltage		
<b>Output for expansion axis</b>				
<b>DC link voltage</b>	$V_{DC}$	460 ... 720		
<b>DC link output current (<math>I_n</math>)</b>	$A_{DC}$	40		
<b>Max. electronics output current for expansion axis</b>	$A_{24Vmax}$	20		
<b>General data</b>				
<b>Electronics current drawn at 24 V DC</b>				
without external fan unit	A	1.5	1.5	1.5
with external fan unit	A	2.3	2.3	2.3
<b>Total power loss</b>	W	425	537	634
(including losses from the electronics, see Power loss tables (Page 316))				
internal	W	81	91	102
external	W	344	446	532
The external 6SL3161-0EP00-0AA0 fan module is taken into account for the specified losses – also see Power loss calculation for partial load operation (Page 319).				
<b>Max. ambient temperature</b>				
Without derating	°C	45	45	45
With derating	°C	55	55	55
<b>DC link voltage</b>	$V_{DC}$	460 ... 720		
<b>DC link capacitance</b>	$\mu F$	1645	1880	2115
<b>Overvoltage tripping</b>	$V_{DC}$	820 $\pm$ 2 %		
<b>Undervoltage tripping</b>	$V_{DC}$	380 $\pm$ 2 %		
<b>Circuit breaker/fuse</b> (IEC 60947 and UL)		See Chapter Overcurrent protection by means of line fuses and circuit breakers (Page 38)		
<b>Resulting rated short-circuit current SCCR at 480 V AC</b>	kA	65	65	65
<b>Cooling method</b>		External air cooling		
<b>Cooling air requirement</b>	m <sup>3</sup> /h	160	160	160
<b>Weight</b>	kg	18.35	18.4	18.5

1) The specified power ratings apply to the line voltage range from 380 V to 480 V



Table 4- 21 Technical data of the S120 Combi 4 axes Power Modules

4 axes Power Modules	6SL3111-	4VE21-0EA0	4VE21-6FA0	4VE21-6EA0	4VE22-0HA0
		10 kW / 24 A / 12 A / 12 A / 12 A	16 kW / 18 A / 9 A / 5 A / 5 A	16 kW / 24 A / 9 A / 9 A / 9 A	20 kW / 30 A / 12 A / 9 A / 9 A
<b>Infeed</b>					
<b>Infeed</b>					
Rated power (S1) <sup>1)</sup>	kW (P <sub>n</sub> )	10	16	16	20
Infeed power for S6 duty P <sub>S6</sub> (40 %) <sup>1)</sup>	kW (P <sub>S6</sub> )	13	21	21	26.5
Peak infeed power <sup>1)</sup>	kW (P <sub>max</sub> )	35	35	35	40
<b>Regenerative feedback</b>					
Rated power (S1)	kW (P <sub>n</sub> )	10	16	16	20
Peak regenerative power	kW (P <sub>max</sub> )	35	35	35	40
<b>Supply voltages</b>					
Line voltage	V <sub>AC</sub>	3 AC 380 – 10 % ... 3 AC 480 + 10 %			
Line frequency	Hz	45 ... 66			
Electronics power supply	V <sub>DC</sub>	24 (20.4 ... 28.8)			
<b>Rated input current</b>					
at 400 V AC	A <sub>AC</sub>	16.2	28	28	34
at 380 V AC / 480 V AC	A <sub>AC</sub>	17 /	29 / 25	29 / 25	35 / 30
at 400 V; for S6 duty I <sub>S6</sub> (40 %)	A <sub>AC</sub>	12.8	35.5	35.5	44
at 400 V AC peak current	A <sub>AC</sub>	21.1	56	56	63.5
		56.7			
<b>Spindle</b>					
<b>Output current</b>					
Rated current (I <sub>n</sub> )	A <sub>ACrms</sub>	<b>24</b>	<b>18</b>	<b>24</b>	<b>30</b>
Base-load current (I <sub>H</sub> )	A <sub>ACrms</sub>	20.4	15.3	20.4	25.5
Intermittent duty current for S6 duty I <sub>S6</sub> (40 %) <sup>2)</sup>	A <sub>Crms</sub>	32 at 4 kHz	24	32	40
Peak current (I <sub>max</sub> )	A <sub>Crms</sub>	19.2 at 8 kHz 60	36	48	56
<b>Rated power</b>					
at 540 V DC link voltage	kW	11.7	8.7	11.7	14.4
at 600 V DC link voltage	kW	13	9.7	13	16
<b>Pulse frequency spindle</b>	kHz	4 / 8	4	4	4
<b>Output voltage</b>	V <sub>ACrms</sub>	0 ... 0.7 x DC link voltage			
<b>Feedrate 1</b>					
<b>Output current</b>					
Rated current (I <sub>n</sub> )	A <sub>ACrms</sub>	<b>12</b>	<b>9</b>	<b>9</b>	<b>12</b>
Base-load current (I <sub>H</sub> )	A <sub>ACrms</sub>	10.8	7.7	7.7	10.3
Intermittent duty current for S6 duty I <sub>S6</sub> (40%)	A <sub>ACrms</sub>	16	12	12	16
	A <sub>ACrms</sub>	36	18	18	24
<b>Rated power</b>					
at 540 V DC link voltage	kW	5.8	4.3	4.3	5.8
at 600 V DC link voltage	kW	6.5	4.8	4.8	6.5
<b>Pulse frequency feedrate 1</b>	kHz	4	4	4	4

4.9 Technical data

4 axes Power Modules	6SL3111-	4VE21-0EA0	4VE21-6FA0	4VE21-6EA0	4VE22-0HA0
<b>Output voltage</b>	V <sub>ACrms</sub>	0 ... 0.7 x DC link voltage			
<b>Feedrate 2</b>					
<b>Output current</b>					
Rated current (I <sub>n</sub> )	A <sub>ACrms</sub>	12	5	9	9
Base load current (I <sub>H</sub> )	A <sub>ACrms</sub>	10.8	4.3	7.7	7.7
Intermittent duty current for S6 duty I <sub>S6</sub> (40 %)	A <sub>ACrms</sub>	16	6.5	12	12
Peak current (I <sub>max</sub> )	A <sub>ACrms</sub>	36	10	18	18
<b>Rated power</b>					
at 540 V DC link voltage	kW	5.8	2.4	4.3	4.3
at 600 V DC link voltage	kW	6.5	2.7	4.8	4.8
<b>Pulse frequency feedrate 2</b>	kHz	4	4	4	4
<b>Output voltage</b>	V <sub>ACrms</sub>	0 ... 0.7 x DC link voltage			
<b>Feedrate 3</b>					
<b>Output current</b>					
Rated current (I <sub>n</sub> )	A <sub>ACrms</sub>	12	5	9	9
Base load current (I <sub>H</sub> )	A <sub>ACrms</sub>	10.8	4.3	7.7	7.7
Intermittent duty current for S6 duty I <sub>S6</sub> (40 %)	A <sub>ACrms</sub>	16	6.5	12	12
Peak current (I <sub>max</sub> )	A <sub>ACrms</sub>	36	10	18	18
<b>Rated power</b>					
at 540 V DC link voltage	kW	5.8	2.4	4.3	4.3
at 600 V DC link voltage	kW	6.5	2.7	4.8	4.8
<b>Pulse frequency feedrate 3</b>	kHz	4	4	4	4
<b>Output voltage</b>	V <sub>ACrms</sub>	0 ... 0.7 x DC link voltage			
<b>Output for expansion axis</b>					
<b>DC link voltage</b>	V <sub>DC</sub>	510 ... 720			
<b>DC link output current (I<sub>n</sub>)</b>	A <sub>DC</sub>	18.5	40		
<b>Max. electronics output current for expansion axis</b>	A <sub>24Vmax</sub>	20			
<b>General data</b>					
<b>Electronics current consumption 24 V DC</b>					
without external fan unit	A	1.6	1.6	1.6	1.6
with external fan unit	A	2.4	2.4	2.4	2.4
<b>Total power loss</b>					
(including losses from the electronics, see Power loss tables (Page 123))					
internal	W	115	87	100	113
external	W	655	405	507	620
The external 6SL3161-0EP00-0AA0 fan module is taken into account for the specified losses – also see Power loss calculation for partial load operation (Page 319).					
<b>Max. ambient temperature</b>					
Without derating	°C	45	45	45	45
With derating	°C	55	55	55	55
<b>DC link voltage</b>	V <sub>DC</sub>	460 ... 720			
<b>DC link capacitance</b>	µF	2520	1645	2115	2520

4 axes Power Modules	6SL3111-	4VE21-0EA0	4VE21-6FA0	4VE21-6EA0	4VE22-0HA0
Overvoltage tripping	V <sub>DC</sub>	820 ± 2 %			
Undervoltage tripping	V <sub>DC</sub>	380 ± 2 %			
Circuit breaker/fuse (IEC 60947 and UL)		See Chapter Overcurrent protection by means of line fuses and circuit breakers (Page 38)			
Resulting rated short-circuit current SCCR at 480 V AC	kA	65	65	65	65
Cooling method		External air cooling			
Cooling air requirement	m <sup>3</sup> /h	160	160	160	160
Weight	kg	19.4	18.9	18.95	19.05

1) The specified power ratings apply to the line voltage range from 380 V to 480 V

2) For operation with an 8 kHz pulse frequency, when using duty cycle S6 with a switch-on duration of 40%, a derating to 60% is required. Derating is required for S6 duty I<sub>S6</sub> (40 %), not for peak current I<sub>max</sub>, also see diagram "Rated duty cycles, spindle for a pulse frequency of 8 kHz".

#### 4.9.1 Characteristic curves

The following rated duty cycles apply to the Power Modules:

- 6SL3111-3VE21-6FA0
- 6SL3111-3VE21-6EA0
- 6SL3111-3VE22-0HA0
- 6SL3111-4VE21-6FA0
- 6SL3111-4VE21-6EA0
- 6SL3111-4VE22-0HA0

Rated duty cycles, infeed

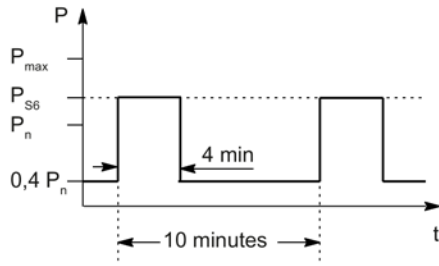

S6 load cycle with preload condition

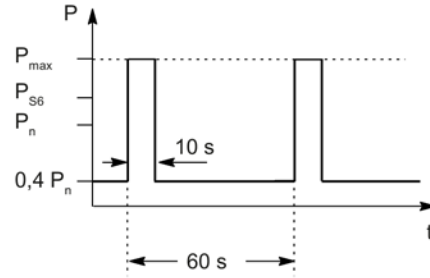

S6 peak power load cycle with preload condition

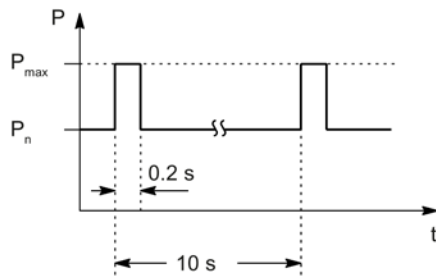

Peak power load cycle with preload condition

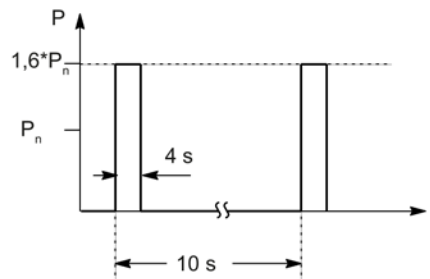

Peak power load duty cycle without pre-load condition

Figure 4-28 Rated duty cycles, infeed

### Rated duty cycles, spindle and feed

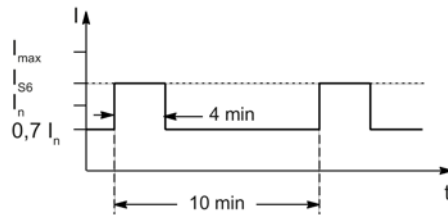

S6 duty cycle with initial load for a duty cycle duration of 600 s

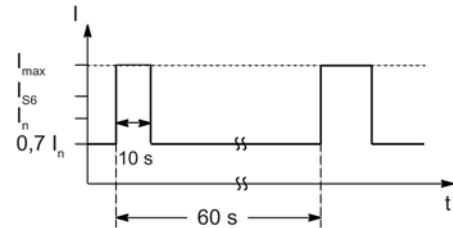

S6 load cycle with preload condition for a 60 s duty cycle

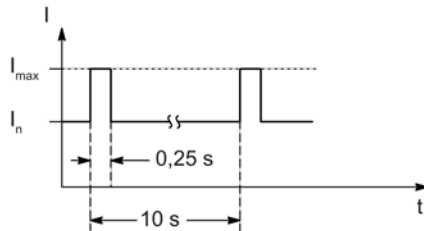

Peak current duty cycle with initial load

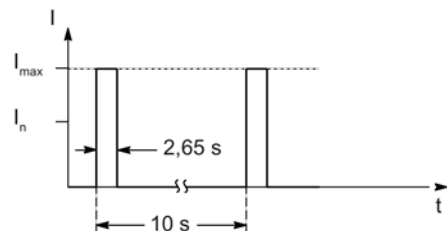

Peak current duty cycle without pre-load condition

Figure 4-29 Rated duty cycles, spindle and feed at a 4 kHz pulse frequency

The following rated duty cycles apply to the Power Modules:

- 6SL3111-4VE21-0EA0

Rated duty cycles, infeed

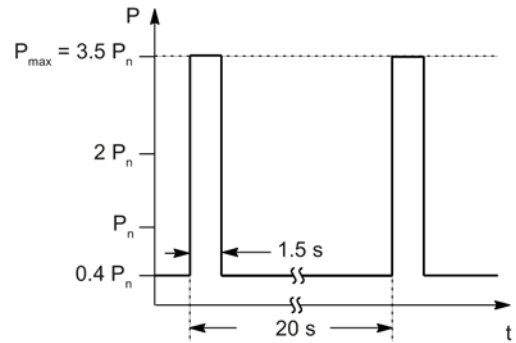
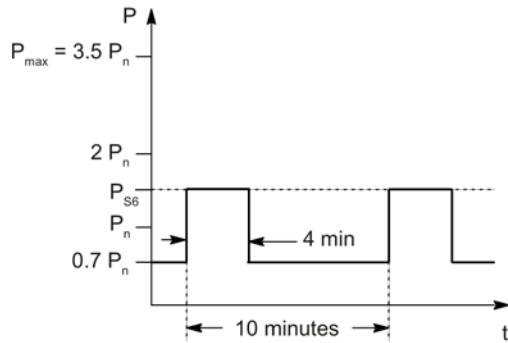

S6 load cycle with preload condition

Peak power load cycle with preload condition

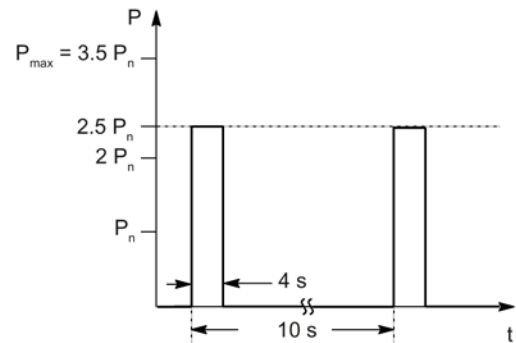
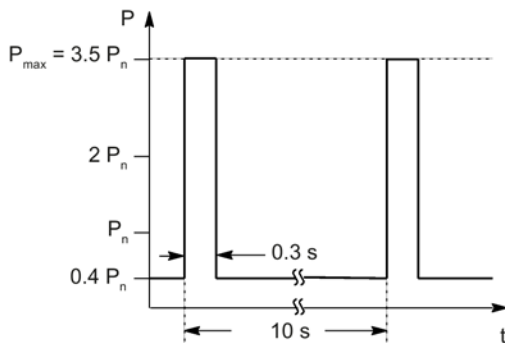

Peak power load cycle with preload condition

Peak power load duty cycle without pre-load condition

Figure 4-30 Rated duty cycles, infeed, 6SL3111-4VE21-0EA0

Rated duty cycles, spindle

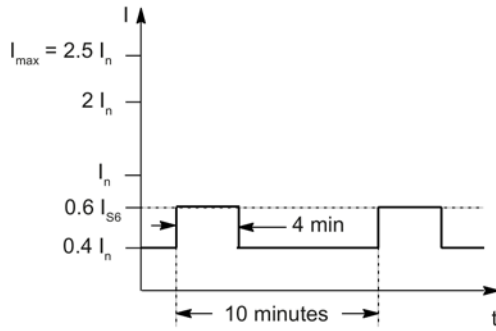

S6 load cycle with preload condition for a 600 s duty cycle

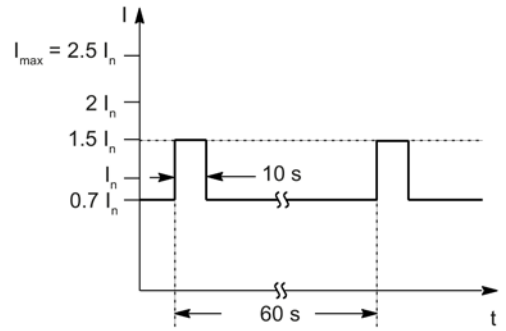

S6 load cycle with preload condition for a 60 s duty cycle

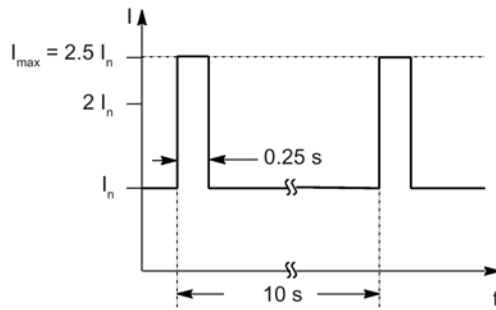

Peak current duty cycle with initial load

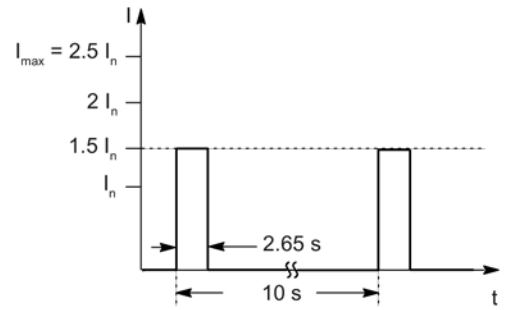

Duty cycle without initial load

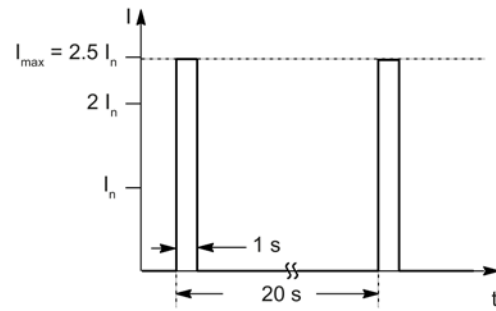

Peak current duty cycle without pre-load condition

Figure 4-31 Rated duty cycles, spindle for a 4 kHz pulse frequency

4.9 Technical data

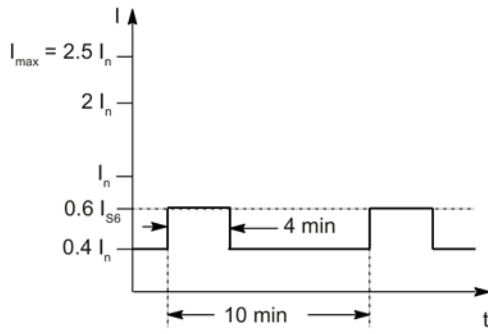

S6 duty cycle with initial load for a duty cycle duration of 600 s

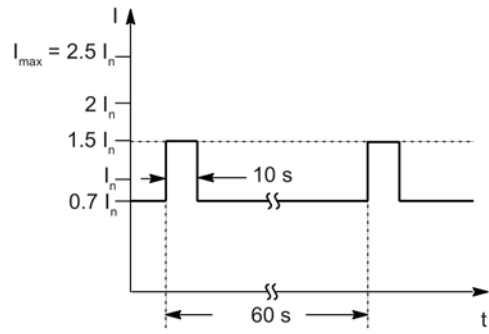

S6 duty cycle with initial load for a duty cycle duration of 60 s

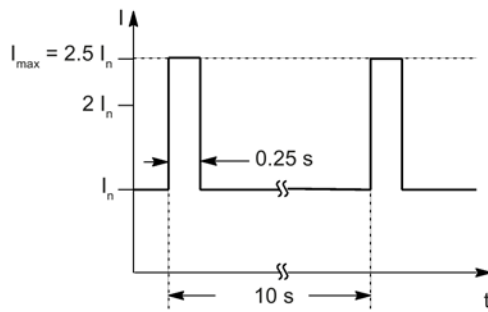

Peak current duty cycle with initial load

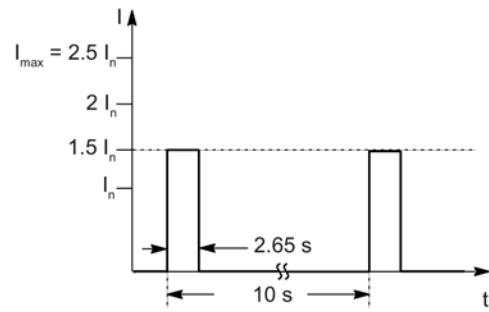

Duty cycle without initial load

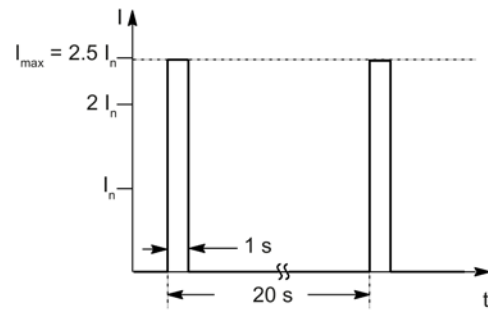

Peak current duty cycle without initial load

Figure 4-32 Rated duty cycles, spindle for a 8 kHz pulse frequency



Rated duty cycles, feed

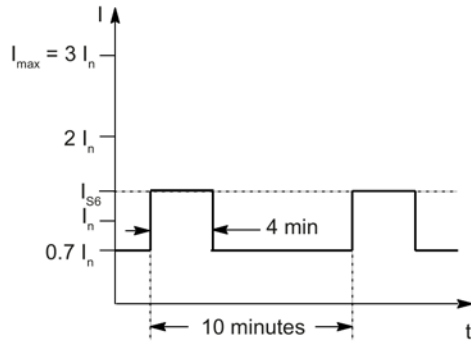

S6 duty cycle with initial load for a duty cycle duration of 600 s

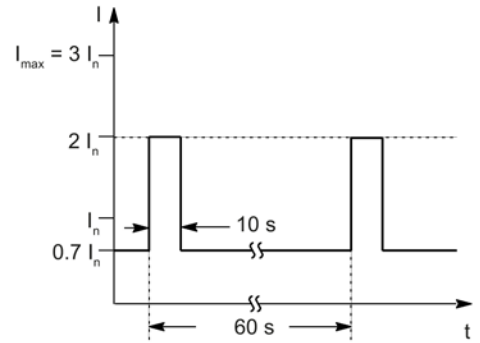

S6 load cycle with preload condition for a 60 s duty cycle

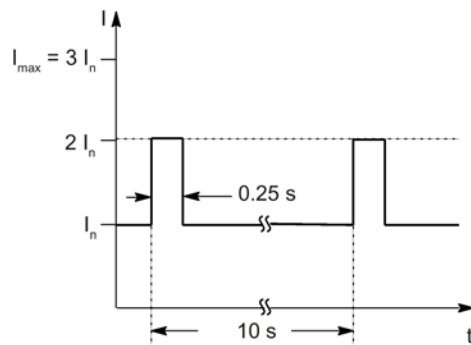

Duty cycle with initial load

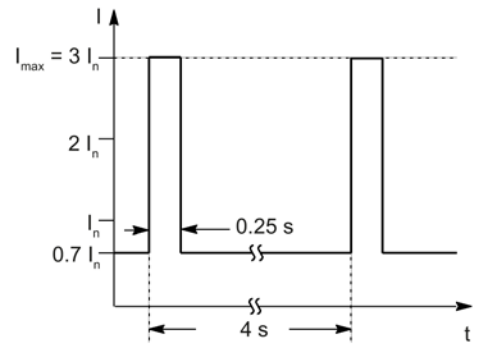

Peak current duty cycle with initial load

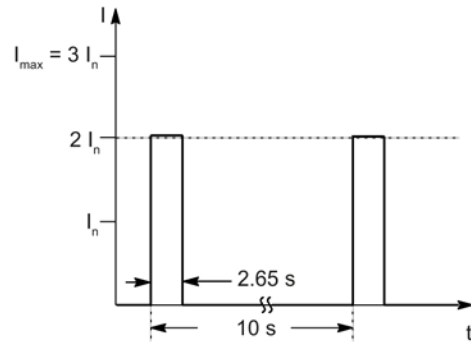

Duty cycle without initial load

Figure 4-33 Rated duty cycles, feed for a 4 kHz pulse frequency

### 4.9.1.1 Derating characteristics

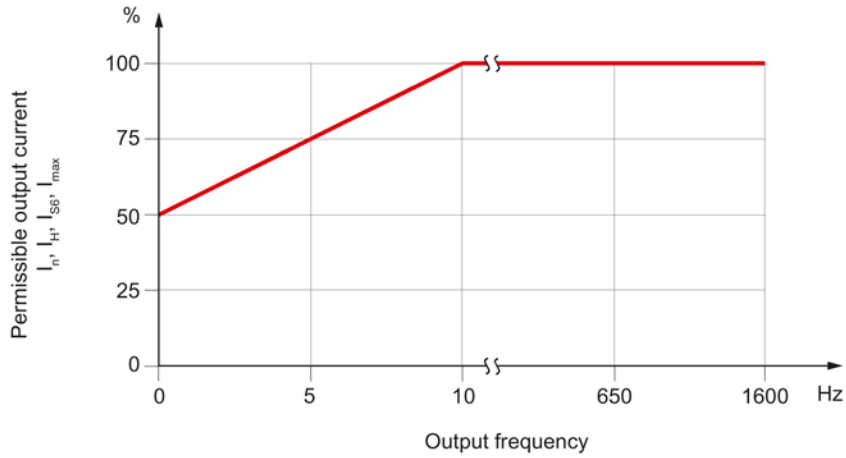

Figure 4-34 Current derating as a function of the output frequency

---

#### Note

You can find the following derating characteristics in Chapter Derating as a function of the installation altitude and ambient temperature (Page 34).

- Output current as a function of the installation altitude
  - Output current as a function of the temperature
-

## Topology rules for DRIVE-CLiQ

### Topology rules for DRIVE-CLiQ

If the S120 Combi is operated in conjunction with the SINUMERIK 828D, then fixed DRIVE-CLiQ topology rules apply. These rules must be observed. If violated, then a corresponding alarm is displayed.

---

#### Note

##### Using the NCU 710.3 PN

There are no fixed topology rules for the SINUMERIK 840D sl.

The DRIVE-CLiQ interfaces X100 to X103 of SINUMERIK NCU 710.3 PN can, for example, be connected with the DRIVE-CLiQ connections of the following devices:

- S120 Combi Power Modules
- Single Motor Module or Double Motor Module
- Hub Module (DM.20)
- Sensor Module (SM...)

The TM54F Terminal Module cannot be used with the SINUMERIK 840D sl.

---

### Assigning the DRIVE-CLiQ interfaces

Table 5- 1 Assigning the DRIVE-CLiQ interfaces on the S120 Combi

DRIVE-CLiQ interface	Connection with
X200	X100 of the PPU
X201	Motor encoder, spindle
X202	Motor encoder, feedrate 1
X203	Motor encoder, feedrate 2
X204	Motor encoder, feedrate 3 ⇒ only for 4-axis Power Modules remains empty for 3-axis Power Modules
X205	Optional: 2nd direct sin/cos encoder for spindle (via SM...) <sup>1)</sup> remains empty when a direct TTL spindle encoder is connected via X220

<sup>1)</sup> In this case, the TTL encoder interface X220 remains free.

Table 5- 2 Assigning the DRIVE-CLiQ interfaces to the SINUMERIK 828D (PPU)

DRIVE-CLiQ interface	Connection with
X100	X200 of the S120 Combi
X101	X200 of a Single Motor Module or Double Motor Module
X102	X500 of the Terminal Module TM54F X500 of the Hub Module (DM.20) <sup>1)</sup>

<sup>1)</sup> When using a TM54F, the DM.20 is connected in series at the TM54F via the DRIVE-CLiQ interface X501

Table 5- 3 Assigning the DRIVE-CLiQ interfaces of the expansion axes

DRIVE-CLiQ interface	Connection with
First Single Motor Module	
X200	X101 of the PPU
X201 <sup>1)</sup>	X200 of the second Single Motor Module
X202	Motor encoder for feedrate 1st expansion axis (via Sensor Module)
Second Single Motor Module	
X200	X201 of the first Single Motor Module
X201	Remains empty
X202	Motor encoder for feedrate 2nd expansion axis (via Sensor Module)
Double Motor Module	
X200	X101 of the PPU
X201	Remains empty
X202	Motor encoder for feedrate 1st expansion axis
X203	Motor encoder for feedrate 2nd expansion axis

<sup>1)</sup> Remains empty if only one Single Motor Module is used

Table 5- 4 Assigning the DRIVE-CLiQ interfaces at the TM54F

DRIVE-CLiQ interface	
X500	X102 of the control (PPU)
X501	X500 of the DMx20 if a DMx20 is not used, then this interface remains empty

Table 5- 5 Assigning the DRIVE-CLiQ interfaces at the DMx20 to assign a direct measuring system to the feed axes.

DRIVE-CLiQ interface	Feed axis
X500	X501 of the TM54F X102 of the PPU <sup>1)</sup> X100 ... X103 of the NCU
X501	Feedrate 1 at the S120 Combi
X502	Feedrate 2 at the S120 Combi
X503	Feedrate 3 at the S120 Combi (4 axes Power Modules)
X504	Feedrate 1st expansion axis at the Motor Module
X505	Feedrate 2nd expansion axis at the Motor Module

<sup>1)</sup> Only then, if a TM54F is not used

## 5.1 Connection examples

### 5.1.1 Operation with a 3 axes Power Module

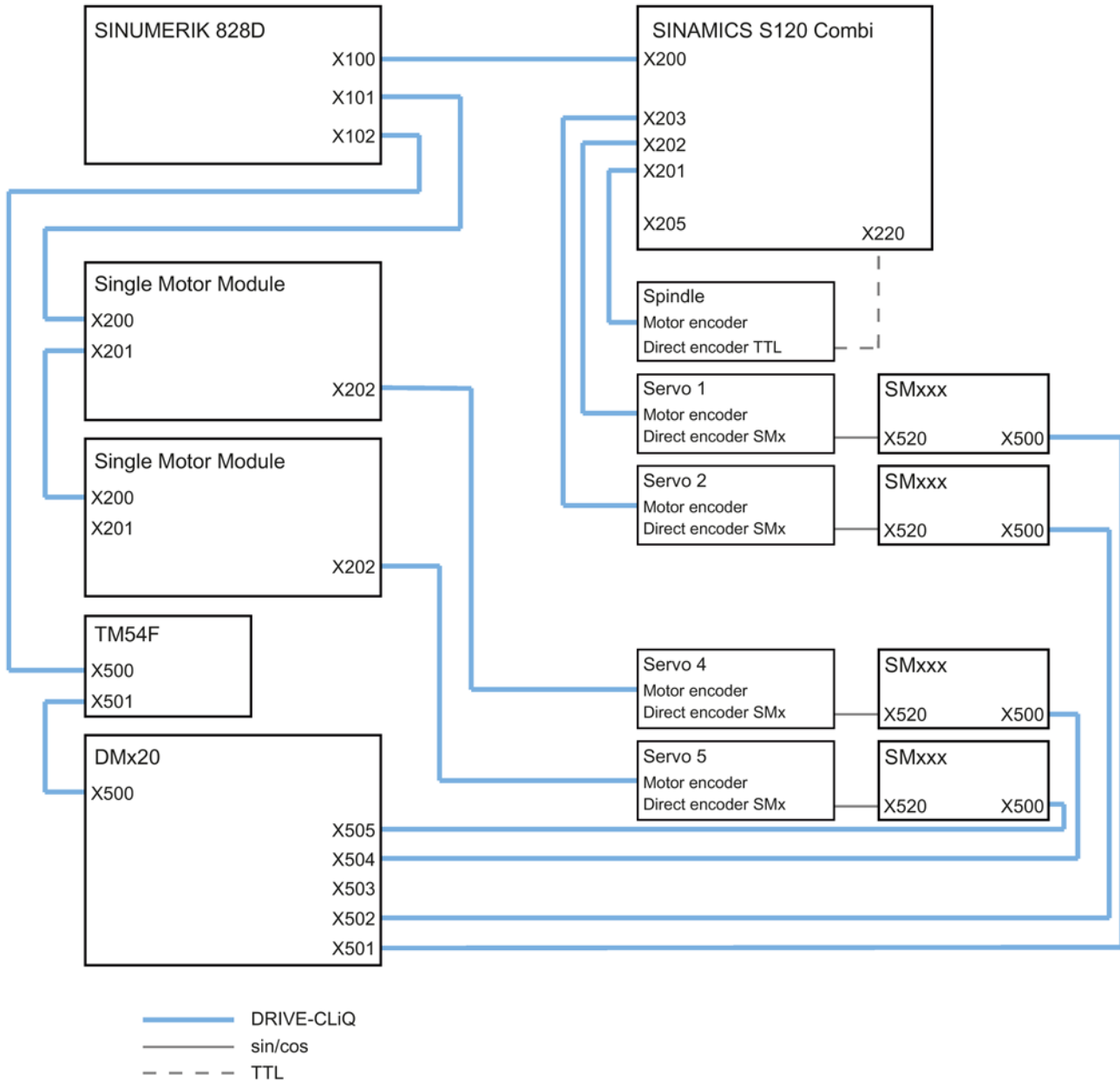

Figure 5-1 DRIVE-CLiQ wiring with TTL encoder for 1 S120 Combi 3-axis Power Module and 2 Single Motor Modules

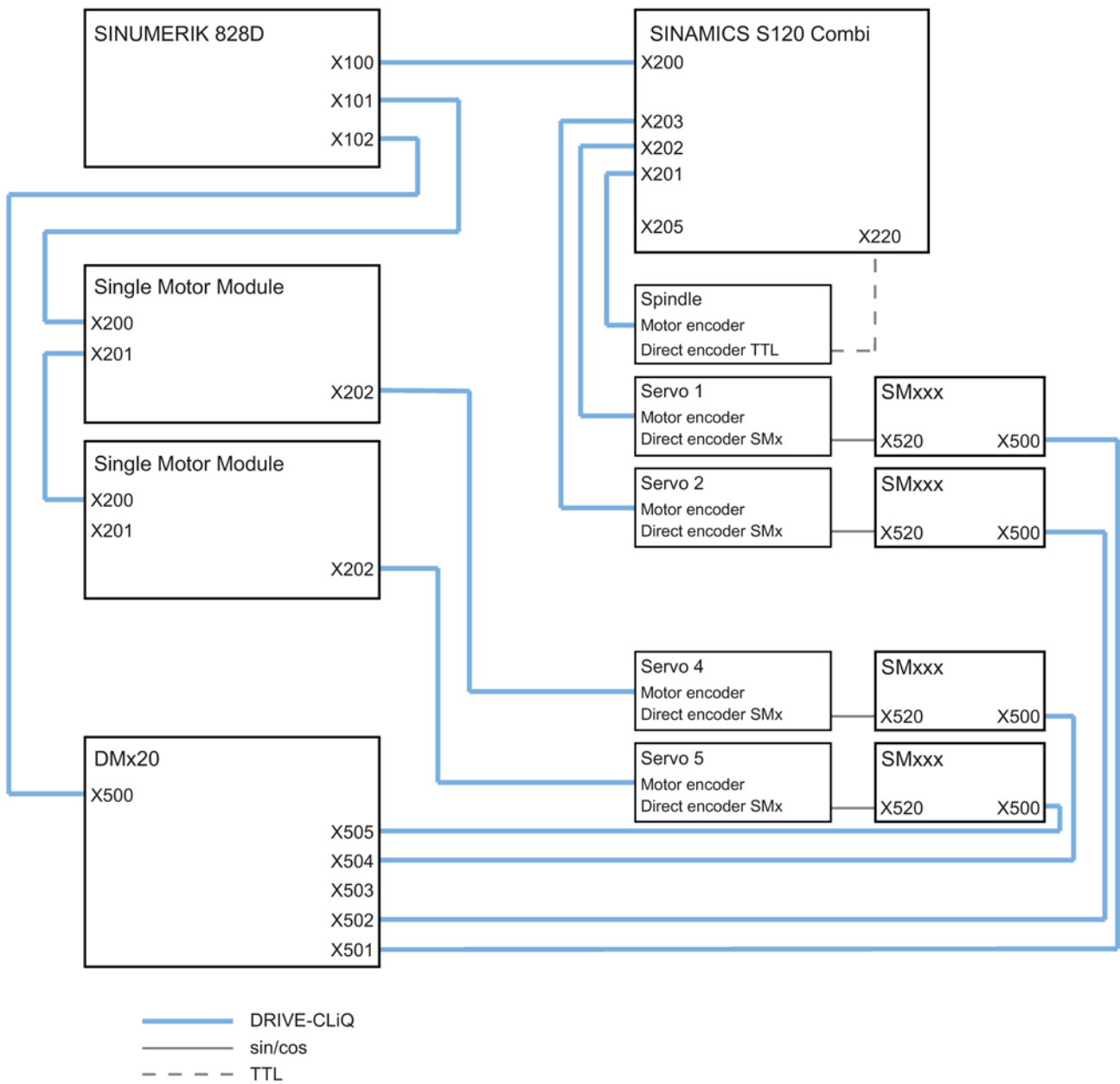

Figure 5-2 DRIVE-CLiQ wiring with TTL encoder for 1 S120 Combi 3-axis Power Module and 2 Single Motor Modules without TM54F

5.1.2 Operation with a 4 axes Power Module

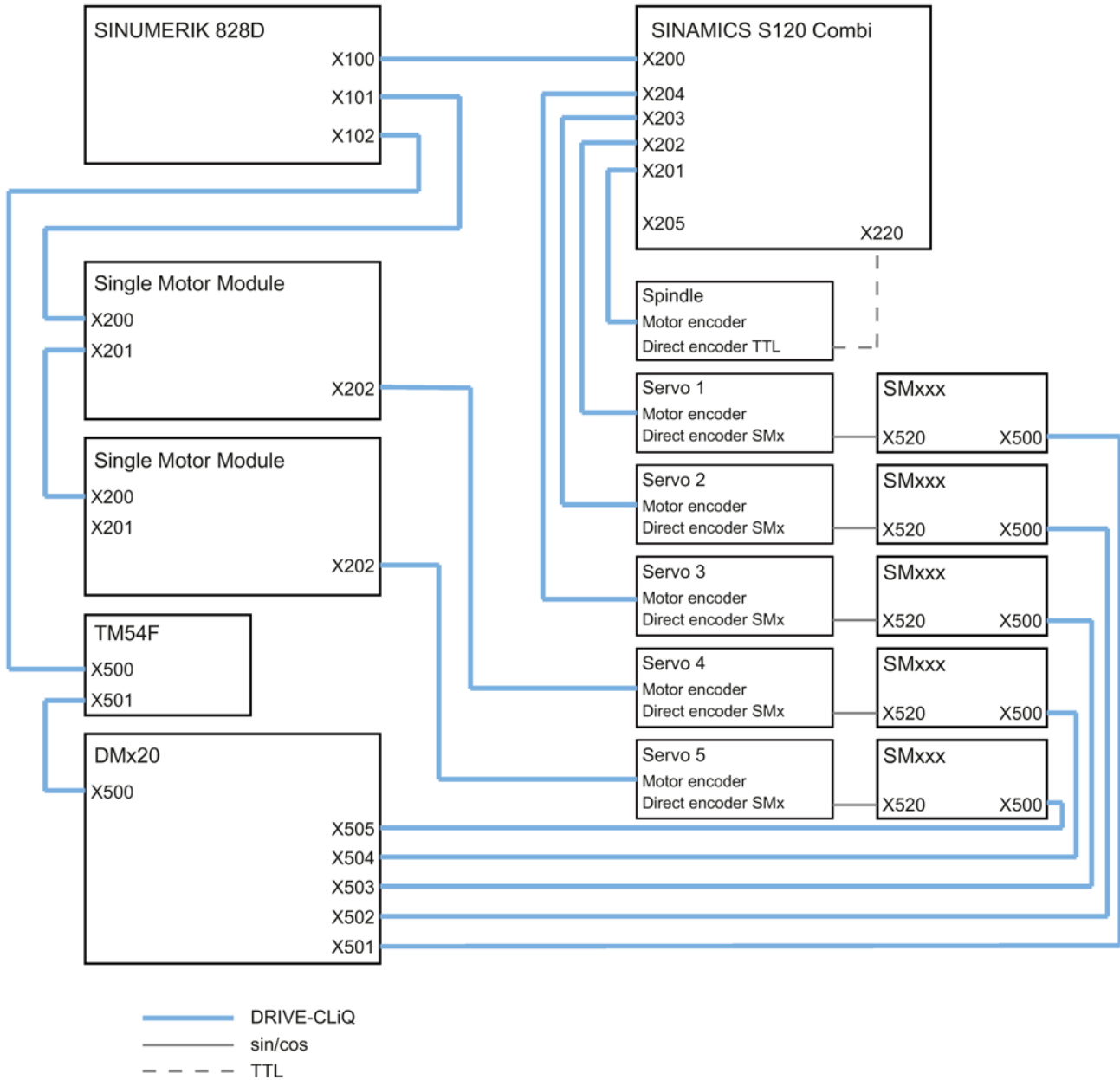

Figure 5-3 DRIVE-CLiQ wiring with TTL encoder for 1 S120 Combi 4-axis Power Module and 2 Single Motor Modules



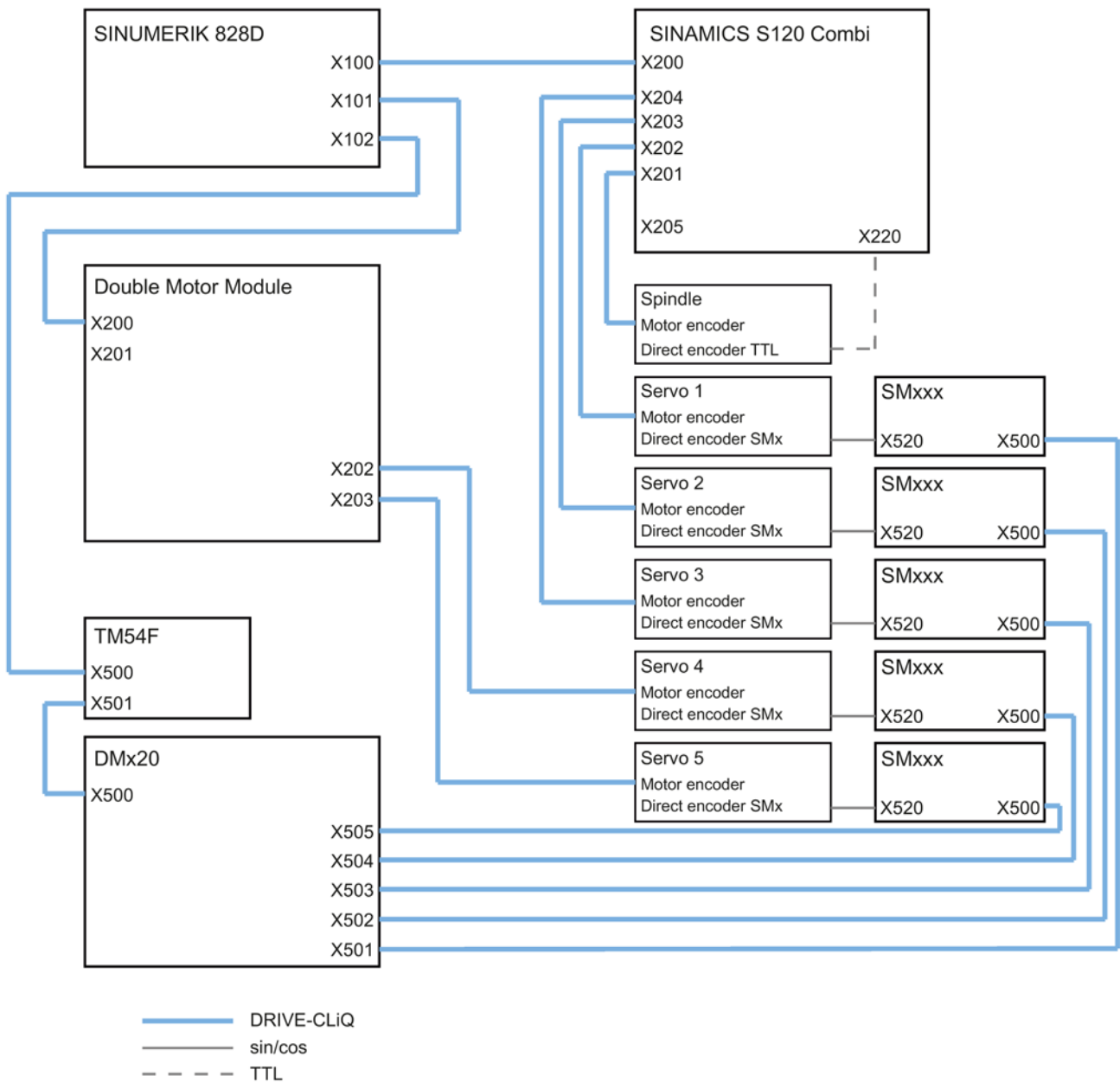

Figure 5-4 DRIVE-CLiQ wiring with TTL encoder for 1 S120 Combi 4-axis Power Module and 1 Double Motor Module

5.1 Connection examples

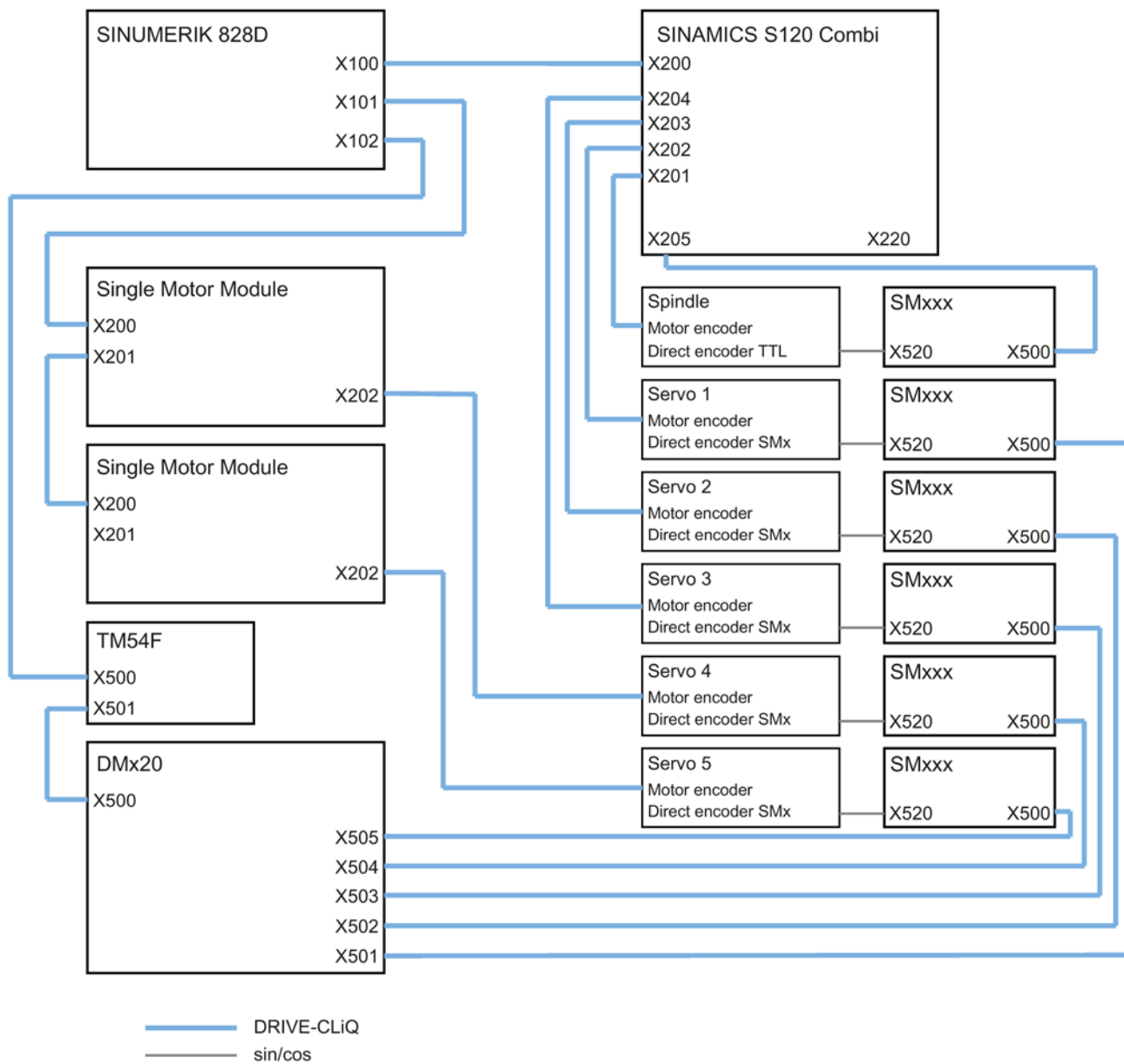

Figure 5-5 DRIVE-CLiQ wiring with angular encoder for 1 S120 Combi 4-axis Power Module and 2 Single Motor Modules

# Motor Modules Booksize Compact as expansion axes

# 6

## 6.1 Description

Motor Modules Booksize Compact are inverters that provide the power for the connected motors. The power is supplied from the DC link of the S120 Combi. If the SINUMERIK 828D control system is used, then the Motor Modules must be connected to this via DRIVE-CLiQ (see Chapter Topology rules for DRIVE-CLiQ (Page 131)).

One motor can be connected to Single Motor Modules and two motors can be connected to Double Motor Modules.

The Motor Modules Booksize Compact are operated in combination with the S120 Combi using the "internal air cooling" cooling method.

---

### Note

For the dimensioning of the expansion axes, the infeed power must be taken into account (demand factor).

---

## 6.2 Safety information

 **WARNING**

**Danger to life if the fundamental safety instructions and remaining risks are not carefully observed**

If the fundamental safety instructions and remaining risks in Chapter 1 (Page 310) are not observed, accidents involving severe injuries or death may occur.

- Adhere to the fundamental safety instructions.
- When assessing the risk, take into account residual risks.



 **DANGER**

**Danger to life through electric shock due to the residual charge of the DC link capacitors**

Due to the DC link capacitors, a hazardous voltage is present in the DC link for up to five minutes after the power supply has been switched off.

Contact with live parts can result in death or serious injury.

- Do not open the protective cover of the DC link until five minutes have elapsed.  
Ensure that you press the release catch when opening the protective cover for the DC link. A suitable tool (e.g. screwdriver or supplied release tool) must be used for this purpose.
- Do not continue to operate damaged components.



 **DANGER**

**Danger to life through electric shock due to inadequate insulation of the motor holding brake cables**

Inadequate insulation of the motor holding brake cables can cause an electric shock.

- Connect the shield for the motor holding brake.
- Only use MOTION-CONNECT cables for the integrated motor holding brake, as otherwise the insulation strength of the cores is not guaranteed.

 **WARNING**

**Danger of an accident due to missing warning labels in the national language regarding the DC link discharge voltage**

Missing warning labels in the national language regarding the DC link discharge voltage can result in death or serious injury.

- Attach the component warning labels in the national language.



**! WARNING**

**Danger to life through interruption of the external protective conductor due to high leakage currents**

The drive components conduct a high leakage current via the protective conductor. Touching conductive parts when the protective conductor is interrupted can result in death or serious injury.

- Ensure that the external protective conductor satisfies at least one of the following conditions:
  - It has been laid so that it is protected against mechanical damage.<sup>1)</sup>
  - If it is a single cable, it has a cross-section of at least 10 mm<sup>2</sup> Cu.
  - If it is a conductor of a multi-conductor cable, it has a cross-section of at least 2.5 mm<sup>2</sup> Cu.
  - It has a second protective conductor in parallel with the same cross-section.
  - It complies with the local regulations for equipment with increased leakage current.

<sup>1)</sup> Cables laid within control cabinets or closed machine housings are considered to be adequately protected against mechanical damage.



**! WARNING**

**Danger to life through electric shock due to unconnected cable shields**

Hazardous touch voltages can occur through capacitive cross-coupling due to unconnected cable shields.

- As a minimum, connect cable shields and the cores of power cables that are not used (e.g. brake cores) at one end at the grounded housing potential.



**! WARNING**

**Danger to life due to electric shock in the event of voltage flashovers at the temperature sensor**

Voltage flashovers in the signal electronics can occur in motors without safe electrical separation of the temperature sensors.

- Only use temperature sensors that fully comply with the specifications of the safety isolation.
- If safe electrical separation cannot be guaranteed (for linear motors or third-party motors, for example), use a Sensor Module External (SME120 or SME125) or Terminal Module TM120.



<b>⚠ WARNING</b>
<b>Danger to life through electric shock due to missing DC link side covers</b>
There is a danger of an electric shock through contact when the side covers of the DC link are missing.
<ul style="list-style-type: none"><li>• Mount the supplied side covers on the first and last component in the drive line-up.</li><li>• You can order missing side covers (article number: 6SL3162-5AA00-0AA0).</li></ul>

<b>NOTICE</b>
<b>Material damage due to loose power connections</b>
Insufficient tightening torques or vibrations can result in faulty electrical connections. This can cause fire damage or malfunctions.
<ul style="list-style-type: none"><li>• Tighten all the DC link busbar screws with the specified tightening torques (1.8 Nm tolerance +30 %).</li><li>• Check the tightening torques of all power connections at regular intervals and tighten them when required. This applies in particular after transport.</li></ul>

<b>NOTICE</b>
<b>Damage through use of incorrect DRIVE-CLiQ cables</b>
Damage or malfunctions can occur on the devices or system when incorrect or unreleased DRIVE-CLiQ cables are used.
<ul style="list-style-type: none"><li>• Only use suitable DRIVE-CLiQ cables that have been released by Siemens for the respective application.</li></ul>

---

**Note**

A regulated DC power supply is required to operate motors with a built-in holding brake. The voltage is supplied via the internal 24 V busbars. The voltage tolerances of the motor holding brakes (24 V ±10%) and the voltage drops of the connecting cables must be taken into account.

The DC power supply should be set to 26 V. This ensures that the supply voltage for the brake remains within the permissible range when the following conditions are fulfilled:

- Use of Siemens three-phase motors
- Use of Siemens MOTION-CONNECT power cables
- Motor cable lengths: max. 70 m

---

**See also**

Fundamental safety instructions (Page 21)

## 6.3 Interface description

### 6.3.1 Overview

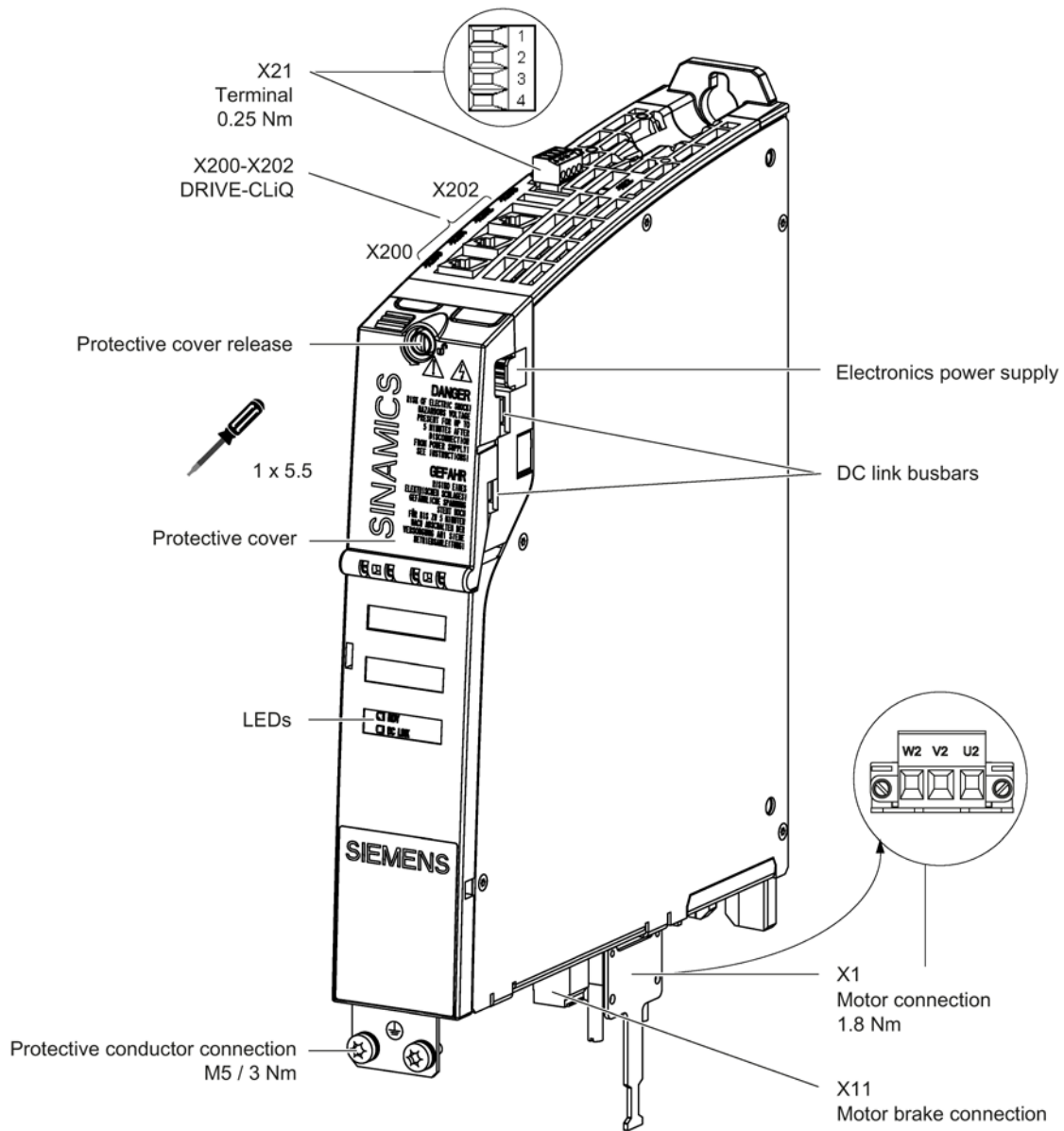

Figure 6-1 Interface overview, Single Motor Module Booksize Compact (example: 5 A)

6.3 Interface description

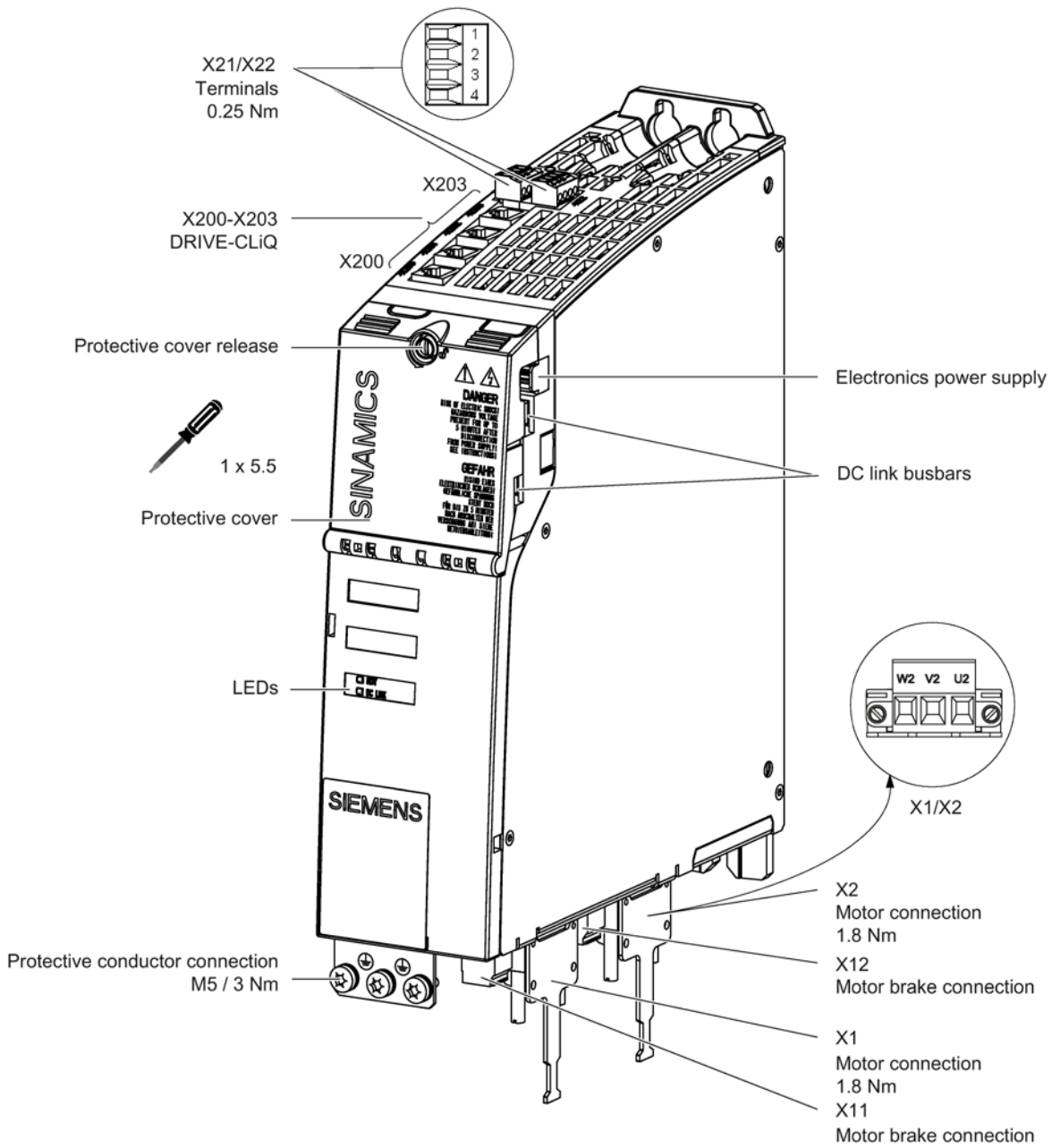
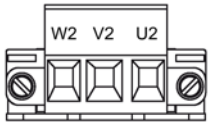
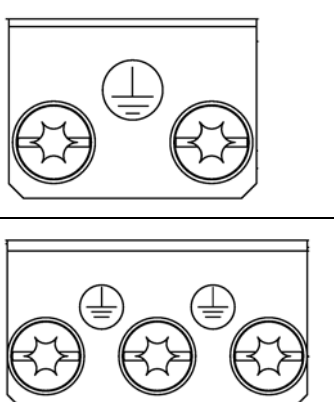

Figure 6-2 Interface overview, Double Motor Module Booksize Compact (example: 2 x 5 A)



### 6.3.2 X1/X2 motor connection

Table 6- 1 X1/X2 motor connection

	Terminal	Technical data
	U2	Type: Screw terminal 5 (Page 307)
	V2	Max. connectable cross-section: 6 mm <sup>2</sup>
	W2	Tightening torque: 1.2 ... 1.5 Nm
	PE connection	<b>Single Motor Modules 3 A to 18 A</b> Type: M5 tapped hole for ring cable lug (Page 308) Tightening torque: 3 Nm
		<b>Double Motor Modules 1.7 A to 5 A</b> Type: M5 tapped hole for ring cable lug (Page 308) Tightening torque: 3 Nm

### 6.3.3 X11/X12 motor brake connection

Table 6- 2 X11/X12 brake connection

	Terminals	Designation	Technical data
	BR+	Brake connection +	Voltage: 24 V DC Max. load current: 2 A Minimum load current: 0.1 A Type: Spring-loaded terminal 1 (Page 306) Max. cross-section that can be connected: 2.5 mm <sup>2</sup> Manufacturer: Wago Article number: 721-102/026-000/56-000
	BR-	Brake connection -	

The brake connector is included in the scope of delivery.

The circuit for protecting the brake against overvoltage is integrated in the Motor Module and does not need to be installed externally.

**Note**

The motor brake must be connected via connector X11 on Single Motor Modules, and X11 and X12 on Double Motor Modules. The BR- cable must not be connected directly to electronics ground (M). The shield of the brake cable is only to be connected to the shield plate.



<p><b>! WARNING</b></p> <p><b>Danger to life through electric shock due to a terminal voltage that has not been adjusted</b></p> <p>Contact with live parts can result in death or serious injury.</p> <ul style="list-style-type: none"> <li>• Connect protective extra-low voltages (PELV) to all connections and terminals between 0 and 48 V DC.</li> <li>• Observe the voltage tolerances of the motor holding brakes (24 V ± 10%).</li> </ul>
---

### 6.3.4 X21/X22 EP terminals / temperature sensor Motor Module

Table 6- 3 X21/X22 EP terminals/temperature sensor

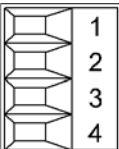
	Terminal	Function	Technical data
	1	+ Temp	Temperature sensors: KTY84–1C130 / PTC / bimetallic switch with NC contact
	2	- Temp	
	3	EP +24 V (Enable Pulses)	Supply voltage: 24 V DC (20.4 ... 28.8 V) Current consumption: 10 mA Isolated input Signal propagation times: L → H: 100 µs H → L: 1000 µs The pulse inhibit function is only available when Safety Integrated Basic Functions are enabled.
	4	EP M1 (Enable Pulses)	
			Type: Screw terminal 1 (Page 307) Max. connectable cross-section: 1.5 mm <sup>2</sup> Tightening torque: 0.22 ... 0.25 Nm

#### Note

The function of the EP terminals is only available when Safety Integrated Basic Functions are enabled.

#### NOTICE

##### Damage due to an incorrectly connected KTY temperature sensor

If the KTY temperature sensor was not connected with the correct polarity, motor overheating may not be detected.

- Connect the KTY temperature sensor with the correct polarity.

#### Note

The temperature sensor input is not needed if the motors feature an integrated DRIVE-CLiQ interface or if temperature values are detected by means of a different module (SMC, SME).



#### ⚠ WARNING

##### Danger to life through electric shock due to temperature sensors that are not permitted

There is a risk of electric shock if temperature sensors that do not comply with the protective separation specifications are connected to terminals "+Temp" and "-Temp".

- Only use temperature sensors that fully comply with the specifications for protective separation.

6.3 Interface description

6.3.5 X200-X203 DRIVE-CLiQ interface

Table 6- 4 X200-X202: DRIVE-CLiQ interfaces for Single Motor Modules  
X200-X203: DRIVE-CLiQ interfaces for Double Motor Modules

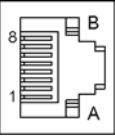
	Pin	Name	Technical specifications
	1	TXP	Transmit data +
	2	TXN	Transmit data -
	3	RXP	Receive data +
	4	Reserved, do not use	
	5	Reserved, do not use	
	6	RXN	Receive data -
	7	Reserved, do not use	
	8	Reserved, do not use	
	A	+ (24 V)	Power supply
	B	M (0 V)	Electronics ground

The blanking covers for the DRIVE-CLiQ interfaces are included in the scope of delivery.

Blanking cover (50 pcs.) Article number: 6SL3066-4CA00-0AA0

## 6.4 Connection example

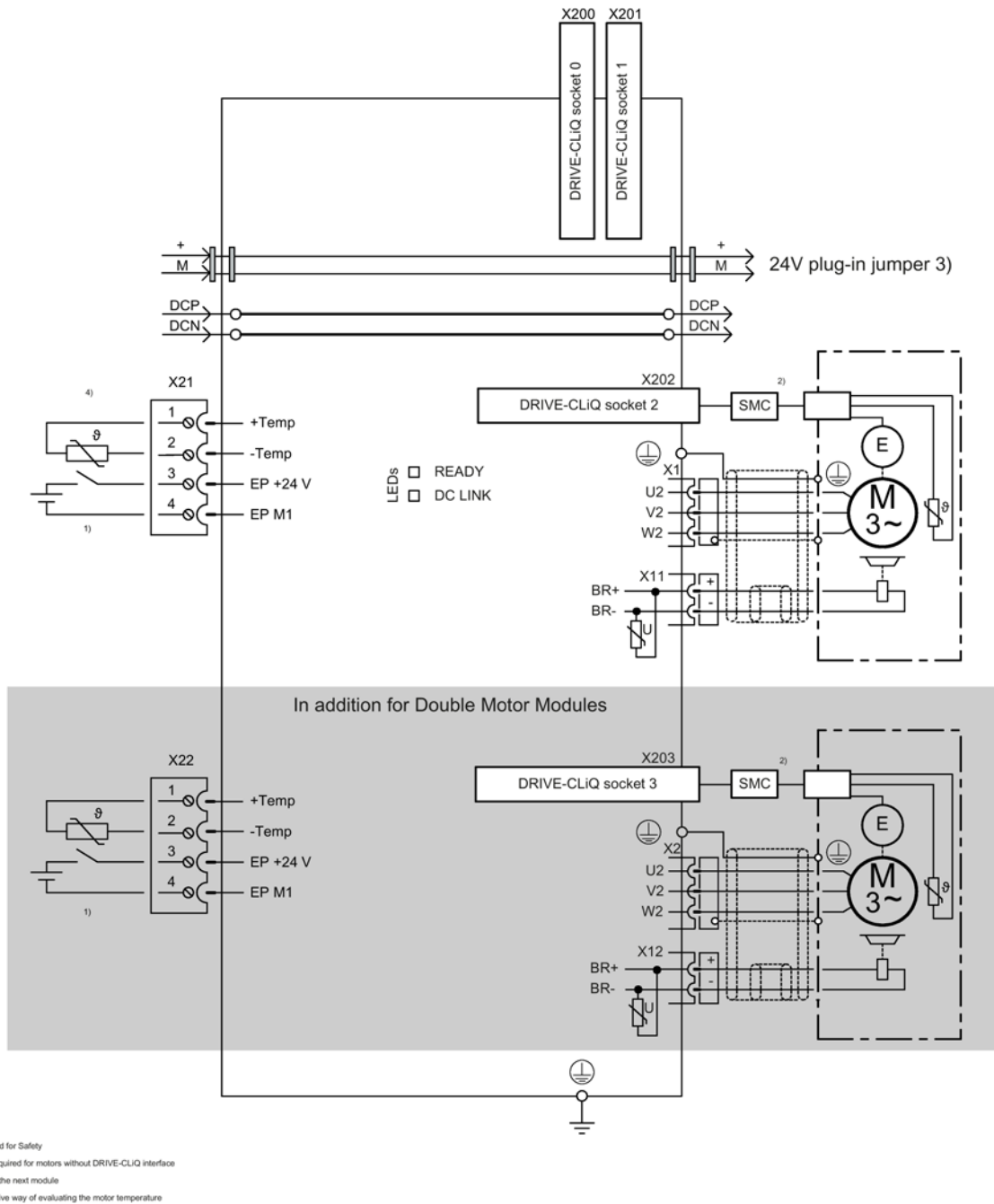

Figure 6-3 Connection example, Single Motor Modules Booksize Compact 3 A to 18 A and Double Motor Modules Booksize Compact 2 x 1.7 A to 2 x 5 A

## 6.5 Meaning of the LEDs on the Motor Module Booksize Compact

Table 6- 5 Meaning of the LEDs on the Single Motor Module/Double Motor Module

Status		Description, cause	Remedy
<b>RDY</b>	<b>DC LINK</b>		
OFF	OFF	The electronics power supply is missing or outside the permissible tolerance range.	–
Green	--	The component is ready for operation. Cyclic DRIVE-CLiQ communication is taking place.	–
	Orange	The component is ready for operation. Cyclic DRIVE-CLiQ communication is taking place. The DC link voltage is present.	–
	Red	The component is ready for operation. Cyclic DRIVE-CLiQ communication is taking place. The DC link voltage is too high.	Check the line supply voltage.
Orange	Orange	DRIVE-CLiQ communication is being established.	–
Red	--	This component has at least one fault. <b>Note:</b> The LED is activated regardless of whether the corresponding messages have been reconfigured.	Remedy and acknowledge fault
Green / Red (0.5 Hz)	--	Firmware is being downloaded.	–
Green / Red (2 Hz)	--	Firmware download is complete. Wait for POWER ON.	Carry out a POWER ON
Green / Orange or Red / Orange	--	Component recognition via LED is activated. This function can be parameterized (see SINAMICS S120/S150 List Manual). <b>Note:</b> Both possibilities depend on the status of the LED when activating.	–



<p><b>! WARNING</b></p> <p><b>Danger to life through electric shock due to applied DC link voltage</b></p> <p>Irrespective of the state of the LED "DC LINK", hazardous DC-link voltages can always be present.</p> <p>Death or serious injury can result when live parts are touched.</p> <ul style="list-style-type: none"> <li>• Observe the warning information on the component.</li> </ul>
--

## 6.6 Dimension drawings

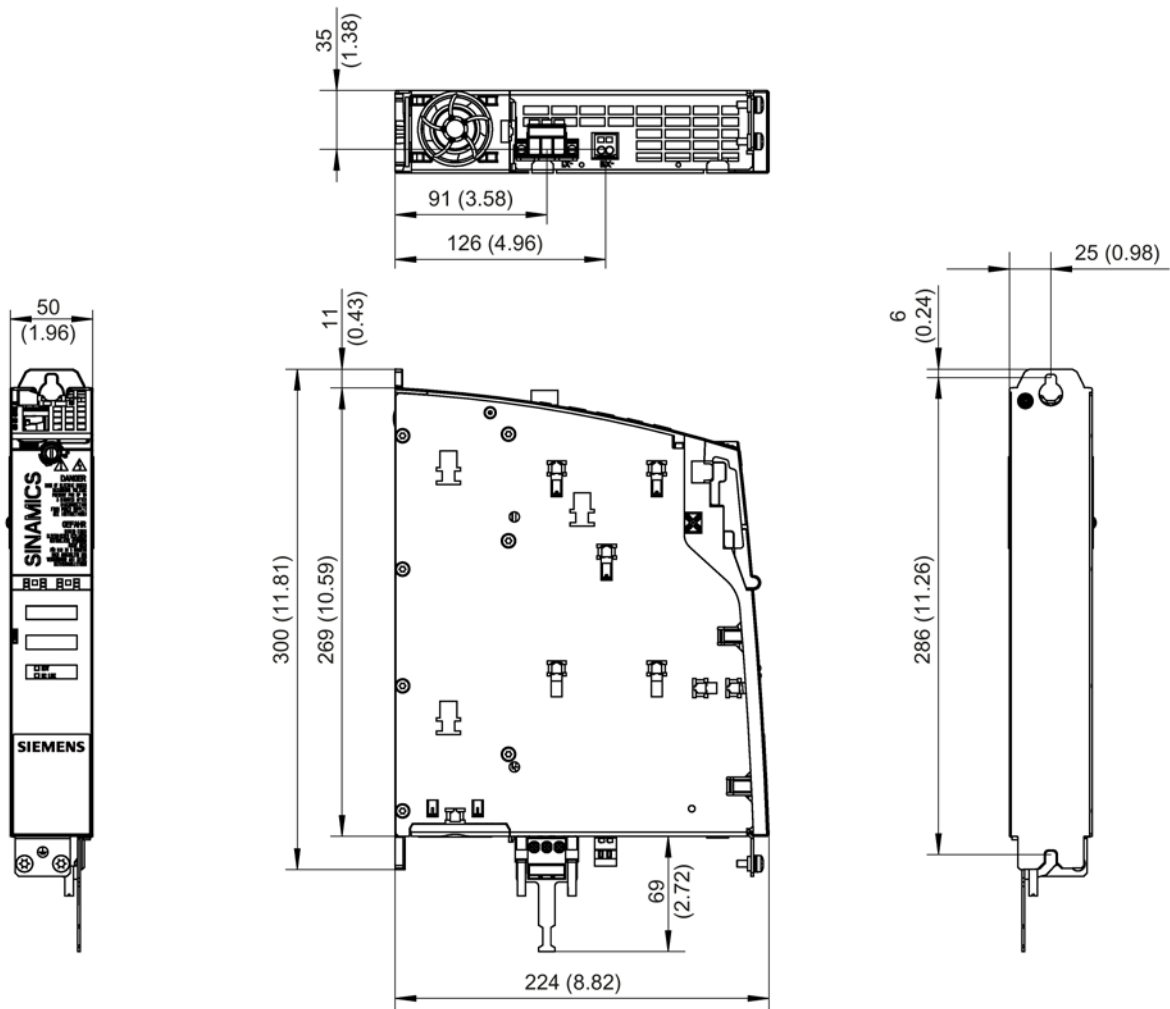

Figure 6-4 Dimension drawing of 3 A, 5 A, and 9 A Motor Modules Booksize Compact, all dimensions in mm and (inches); example: 5 A Single Motor Module

Table 6- 6 Motor Modules Booksize Compact 3 A, 5 A, and 9 A

Motor Module	Article No.
Single Motor Module 3 A	6SL3420-1TE13-0AA.
Single Motor Module 5 A	6SL3420-1TE15-0AA.
Single Motor Module 9 A	6SL3420-1TE21-0AA.

6.6 Dimension drawings

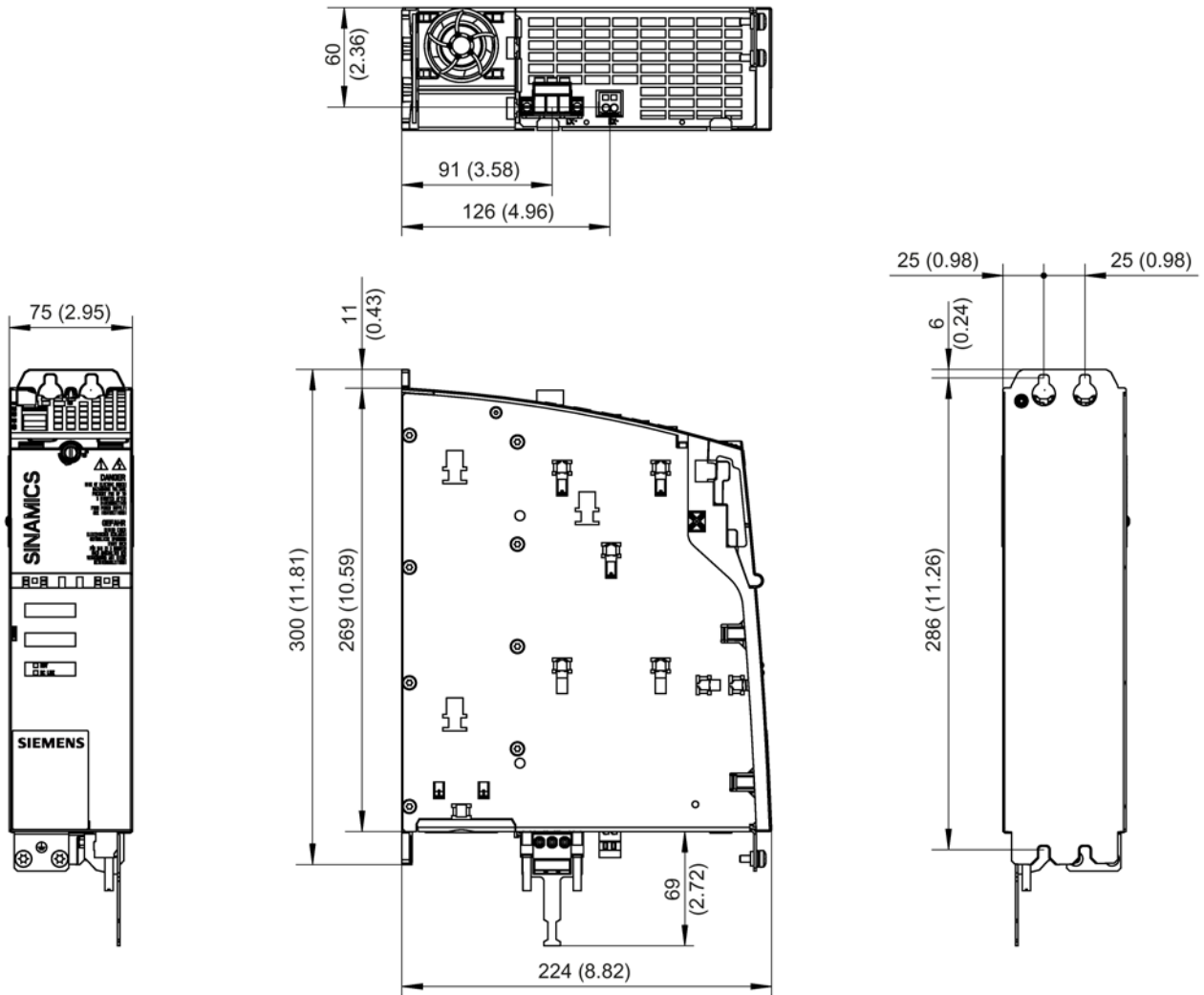

Figure 6-5 Dimension drawing of 18 A Motor Module Booksize Compact, all dimensions in mm and (inches)

Table 6-7 Motor Module Booksize Compact 18 A

Motor Module	Article No.
Single Motor Module 18 A	6SL3420-1TE21-8AA.



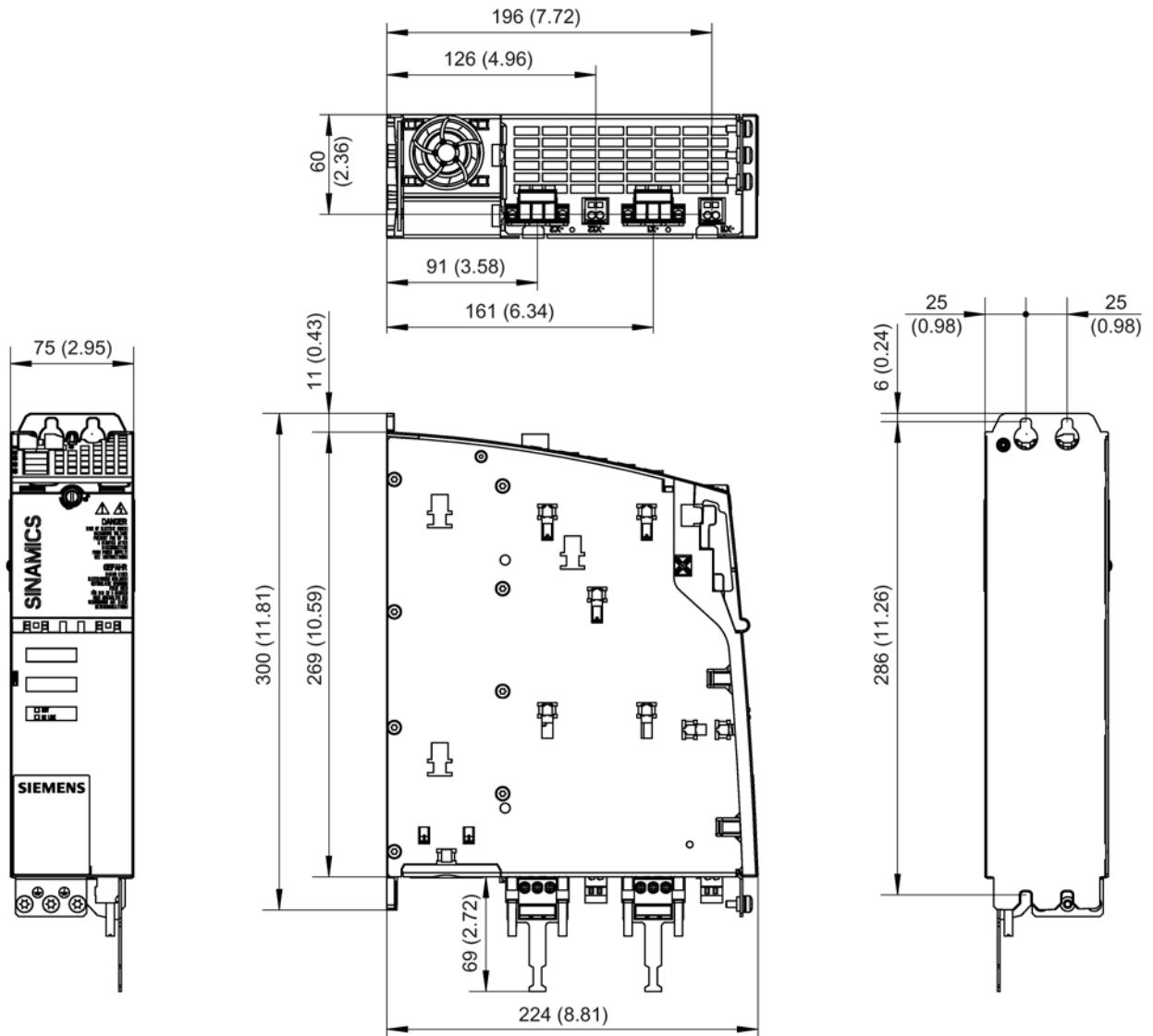

Figure 6-6 Dimension drawing of 2 x 1.7 A, 2 x 3 A, and 2 x 5 A Double Motor Modules Compact, all dimensions in mm and (inches); example: 2 x 5 A Double Motor Module

Table 6- 8 2 x 1.7 A, 2 x 3 A, and 2 x 5 A Double Motor Modules Booksize Compact

Double Motor Module	Article No.
2 x 1.7 A Double Motor Module	6SL3420-2TE11-7AA.
2 x 3 A Double Motor Module	6SL3420-2TE13-0AA.
2 x 5 A Double Motor Module	6SL3420-2TE15-0AA.

## 6.7 Installation

### Installing a Motor Module Booksize Compact

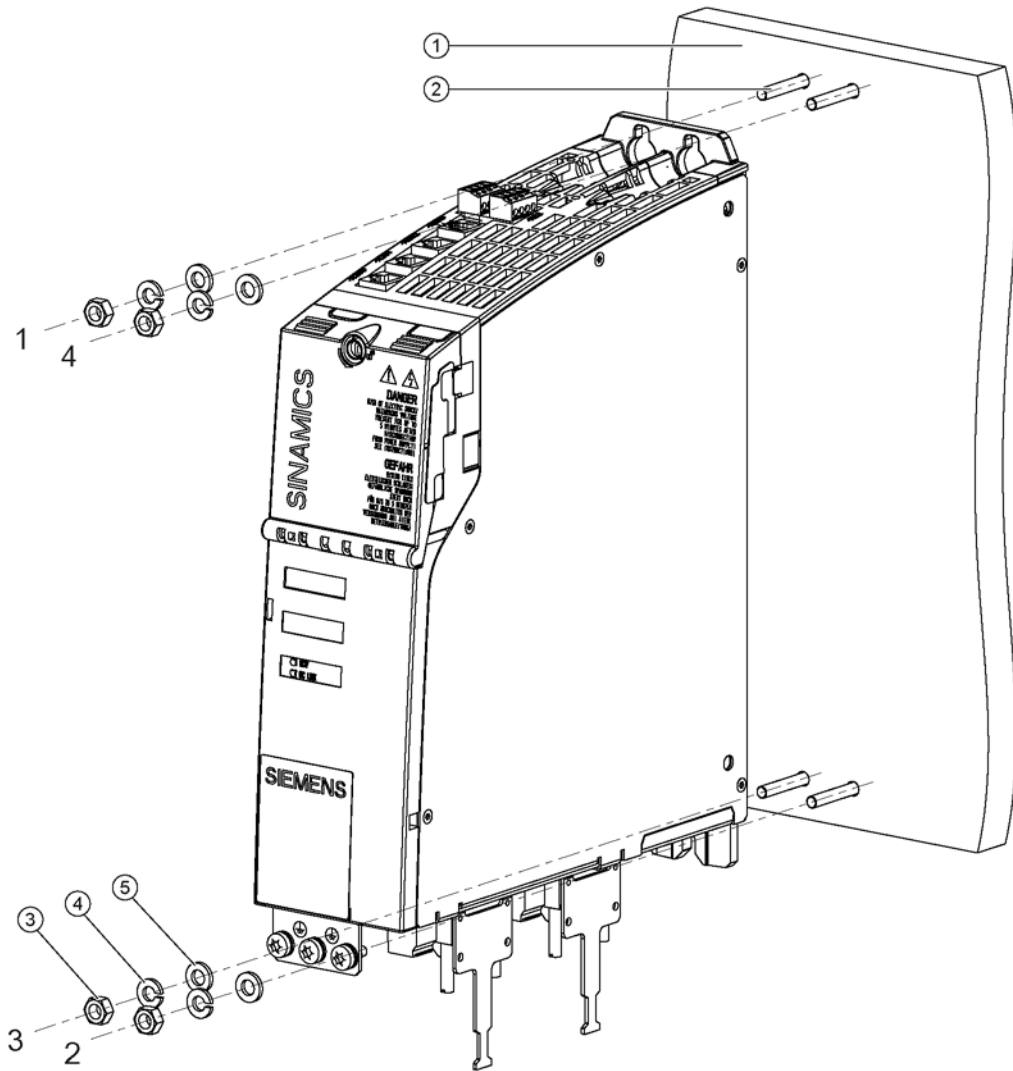

- ① Mounting wall
- ② M6 x 16 screw  
Hex combination screw or hex screw with spring washer and plain washer

Figure 6-7 Installing a Motor Module Booksize Compact with internal air cooling

#### Tightening torques:

- Initially, tighten by hand (0.5 Nm)
- Then tighten with 6 Nm (in the specific sequence 1 to 4)

## 6.8 Technical data

Table 6- 9 Technical data Single Motor Modules Booksize Compact (3 A to 18 A)

Single Motor Modules Booksize Compact	6SL3420–	1TE13-0AA.	1TE15-0AA.	1TE21–0AA.	1TE21–8AA.
<b>Output current</b>					
Rated current ( $I_n$ )	$A_{ACrms}$	<b>3</b>	<b>5</b>	<b>9</b>	<b>18</b>
Base load current ( $I_H$ )	A	2.6	4.3	7.7	15.3
Intermittent duty current for S6 duty $I_{S6}$ (40 %)	$A_{ACrms}$	3.5	6	10	24
Peak current ( $I_{max}$ )	$A_{ACrms}$	9	15	27	54
<b>Output voltage</b>	$V_{ACrms}$	0 ... 0.717 x DC link voltage			
<b>DC link current <math>I_{d max}</math></b>	$A_{DC}$	3.6	6	11	22
<b>DC link voltage</b> (up to 2000 m above sea level)	$V_{DC}$	510 ... 720			
<b>DC link capacitance</b>	$\mu F$	110	110	110	235
<b>Overvoltage tripping</b>	$V_{DC}$	820 $\pm$ 2 %			
<b>Undervoltage tripping<sup>1)</sup></b>	$V_{DC}$	380 $\pm$ 2 %			
<b>Electronics power supply</b>	$V_{DC}$	24 (20.4 ... 28.8)			
<b>Electronics current drawn at 24 V DC</b>	$A_{DC}$	0.85	0.85	0.85	0.85
<b>Current carrying capacity</b>					
DC link busbar	$A_{DC}$	100	100	100	100
Reinforced DC link busbars	$A_{DC}$	150	150	150	150
24 V busbar	$A_{DC}$	20	20	20	20
<b>Max. current motor brake</b>	A	2	2	2	2
<b>Unit rating<sup>2)</sup></b>					
Based on $I_n$ (600 V DC; 4 kHz)	kW	1.6	2.7	4.8	9.7
Based on $I_H$	kW	1.4	2.3	4.1	13.7
<b>Total power loss</b> (including electronics losses) (see Power loss tables (Page 316))	W	68 at 8 kHz	98 at 8 kHz	100.4 at 4 kHz	185.4 at 4 kHz
<b>Max. pulse frequency</b>					
Without derating	kHz	8	8	4	4
With derating	kHz	16	16	16	16
<b>Max. ambient temperature</b>					
Without derating	$^{\circ}C$	40			
With derating	$^{\circ}C$	55			
<b>Sound pressure level</b>	dB(A)	< 60	< 60	< 60	< 60
<b>Cooling method</b>		Internal air cooling			
<b>Cooling air requirement</b>	$m^3/h$	29.6	29.6	29.6	29.6
<b>Weight</b>	kg	2.7	2.7	2.7	3.4

1) Default setting for 400 V line supplies, undervoltage trip threshold can be reduced by up to 80 V and is adjusted to the parameterized line voltage

2) Rated power of a typical standard induction motor at 400 V 3 AC.

6.8 Technical data

Table 6- 10 Technical data Double Motor Modules Booksize Compact (2 x 1.7 A to 2 x 5 A)

Double Motor Modules Booksize Compact	6SL3420-	2TE11-0AA.	2TE13-0AA.	2TE15-0AA.
<b>Output current</b>				
Rated current ( $I_n$ )	$A_{ACrms}$	<b>2 x 1.7</b>	<b>2 x 3</b>	<b>2 x 5</b>
Base load current ( $I_H$ )	A	2 x 1.5	2 x 2.6	2 x 4.3
Intermittent duty current for S6 duty $I_{S6}$ (40 %)	$A_{ACrms}$	2 x 2	2 x 3.5	2 x 6
Peak current ( $I_{max}$ )	$A_{ACrms}$	2 x 5.1	2 x 9	2 x 15
<b>Output voltage</b>	$V_{ACrms}$	0 ... 0.717 x DC link voltage		
<b>DC link current <math>I_{d max}</math></b>	$A_{DC}$	4.1	7.2	12
<b>DC link voltage</b> (up to 2000 m above sea level)	$V_{DC}$	510 ... 720		
<b>DC link capacitance</b>	$\mu F$	165	165	165
<b>Overvoltage tripping</b>	$V_{DC}$	820 $\pm$ 2 %		
<b>Undervoltage tripping<sup>1)</sup></b>	$V_{DC}$	380 $\pm$ 2 %		
<b>Electronics power supply</b>	$V_{DC}$	24 (20.4 ... 28.8)		
<b>Electronics current drawn at 24 V DC</b>	$A_{DC}$	1.15	1.15	1.15
<b>Current carrying capacity</b>				
DC link busbar	A	100	100	100
Reinforced DC link busbars	A	150	150	150
24 V busbar	A	20	20	20
<b>Max. current motor brake</b>	A	2 x 2	2 x 2	2 x 2
<b>Unit rating<sup>2)</sup></b>				
Based on $I_n$ (600 V, 8 kHz)	kW	2 x 0.9	2 x 1.6	2 x 2.7
Based on $I_H$	kW	2 x 0.8	2 x 1.4	2 x 2.3
<b>Total power loss</b> (including electronics losses) at 8 kHz (see Power loss tables (Page 316))	W	114	134	194
<b>Max. pulse frequency</b>				
Without derating	kHz	8	8	8
With derating	kHz	16	16	16
<b>Max. ambient temperature</b>				
Without derating	$^{\circ}C$	40		
With derating	$^{\circ}C$	55		
<b>Sound pressure level</b>	dBA	< 60	< 60	< 60
<b>Cooling method</b>		Internal air cooling using an integrated fan		
<b>Cooling air requirement</b>	$m^3/h$	29.6	29.6	29.6
<b>Weight</b>	kg	3.4	3.4	3.4

1) Default setting for 400 V line supplies, undervoltage trip threshold can be reduced by up to 80 V and is adjusted to the parameterized line voltage

2) Rated power of a typical standard induction motor at 400 V 3 AC.

## 6.8.1 Characteristics

### Rated duty cycles Motor Modules Booksize Compact

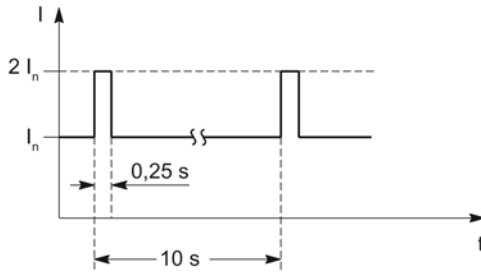

Figure 6-8 Duty cycle with preload

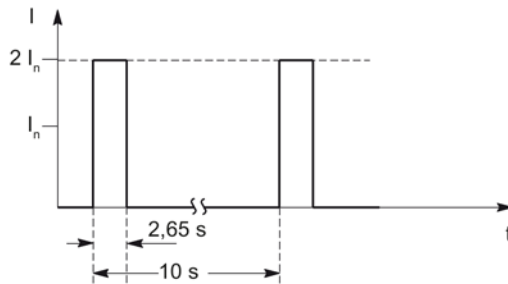

Figure 6-9 Duty cycle without initial load

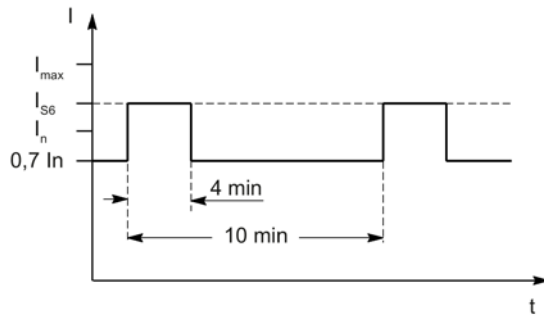

Figure 6-10 S6 duty cycle with initial load with a duty cycle duration of 600 s

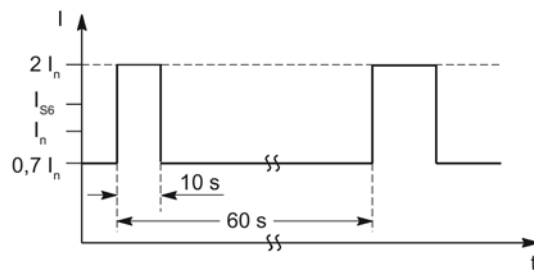

Figure 6-11 S6 duty cycle with initial load with a duty cycle duration of 60 s

6.8 Technical data

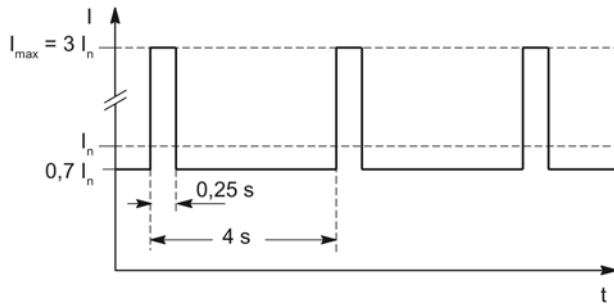

Figure 6-12 Peak current duty cycle with initial load

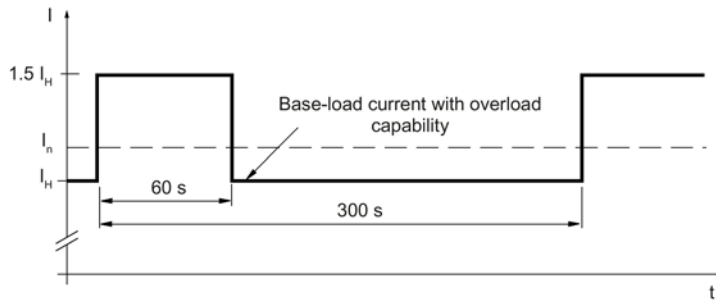

Figure 6-13 Duty cycle with 60 s overload with a duty cycle duration of 300 s

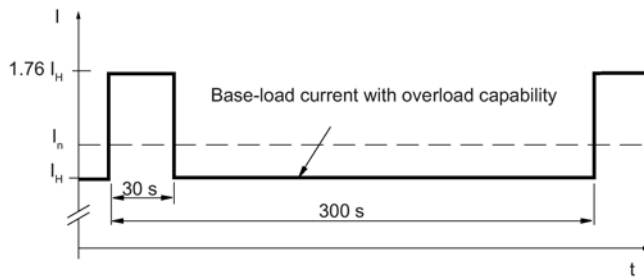

Figure 6-14 Duty cycle with 30 s overload with a duty cycle duration of 300 s

Derating characteristics for Motor Modules Booksize Compact

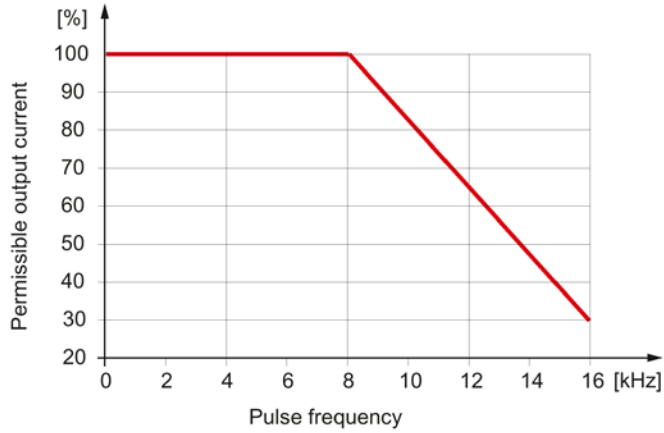

Figure 6-15 Output current as a function of the pulse frequency for the Motor Module ≤ 5 A

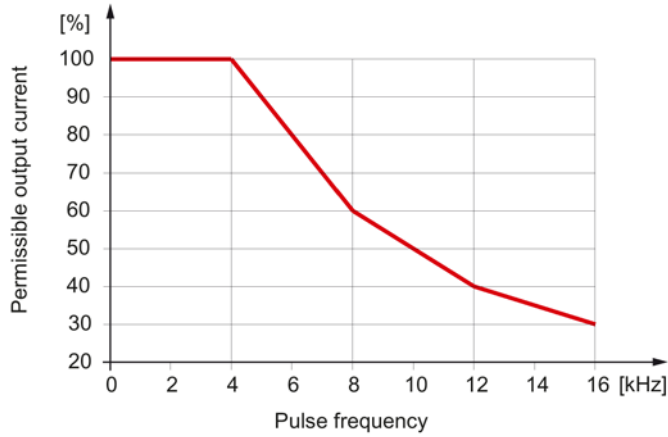

Figure 6-16 Output current as a function of the pulse frequency for the Motor Module ≥ 9 A

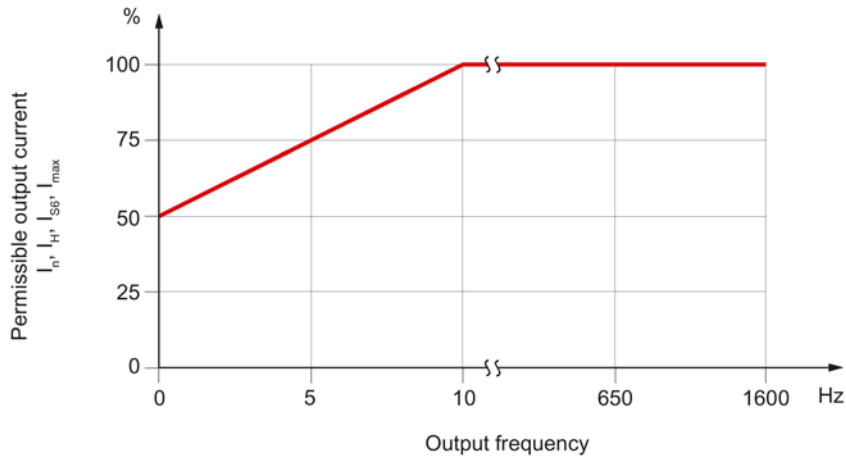

Figure 6-17 Current derating as a function of the output frequency

---

**Note**

You can find the following derating characteristics in Chapter Derating as a function of the installation altitude and ambient temperature (Page 34).

- Output current as a function of the installation altitude
  - Output current as a function of the temperature
-



## DC link components

### 7.1 Control Supply Module CSM

#### 7.1.1 Description

The Control Supply Module provides an output voltage of 24 V - 28.8 V DC. The output voltage can be adjusted using an integrated potentiometer.

In normal operation, the Control Supply Module is supplied from the line voltage. In the event of a power failure, the module automatically changes over to supply from the DC link. This makes it possible, for example, to execute retraction movements in the event of a failure of the line supply.

The Control Supply Module has safe electrical separation between the line potential and the DC-link potential. This therefore ensures that the DC link is not unintentionally charged. The Control Supply Module can therefore remain connected to the line supply if the S120 Combi is electrically isolated from the line supply, for example via a line contactor.

The 24 V ground of the Control Supply Module is internally grounded.  
The Control Supply Module is cooled using an internal fan.

Temperature and voltages are internally monitored.

**Temperature monitoring:**

In the event of an overtemperature in the Control Supply Module, a temperature advance warning is issued via a signaling contact. If the temperature falls below the limit value within the advance warning time, then the module remains operational and the signaling contact is de-energized. If the overtemperature condition persists, the module is switched off and restarted.

**Voltage monitoring:**

When the monitoring threshold (32 V) of the output voltage is exceeded for > 20 ms, the control supply module switches off and attempts a restart after 10 s. This is supplemented by a hardware-based overvoltage limiting. This prevents that more than 35 V can be output in the case of a fault.

The Control Supply Module can either be operated individually or in a parallel connection with a maximum of 10 devices. The switchover between single and parallel operation is realized in a no-current state using a DIP switch on the upper side of the module.

---

**Note**

**Compatibility**

The new Control Supply Module 6SL3100-1DE22-0AA1 with extended functions described here replaces Control Supply Module 6SL3100-1DE22-0AA0. The modules are spare-part-compatible.

---

### 7.1.2 Safety information

	<b>WARNING</b>
<b>Danger to life if the fundamental safety instructions and remaining risks are not carefully observed</b>	
If the fundamental safety instructions and remaining risks in Chapter 1 (Page 21) are not observed, accidents involving severe injuries or death may occur.	
<ul style="list-style-type: none"> <li>• Adhere to the fundamental safety instructions.</li> <li>• When assessing the risk, take into account residual risks.</li> </ul>	



	<b>DANGER</b>
<b>Danger to life when live parts are touched when using the control supply module</b>	
The control supply module has two supply circuits. Death or serious injury can result when live parts are touched.	
<ul style="list-style-type: none"> <li>• Switch off both supply circuits before you start any work.</li> </ul>	



	<b>DANGER</b>
<b>Danger to life through electric shock due to the residual charge of the DC link capacitors</b>	
Due to the DC link capacitors, a hazardous voltage is present in the DC link for up to five minutes after the power supply has been switched off.	
Contact with live parts can result in death or serious injury.	
<ul style="list-style-type: none"> <li>• Do not open the protective cover of the DC link until five minutes have elapsed.</li> <li>• Measure the voltage before starting work on the DCP and DCN DC link terminals.</li> </ul>	



	<b>DANGER</b>
<b>Danger to life through electric shock when the protective cover of the DC link is open</b>	
Contact with live parts can result in death or serious injury.	
<ul style="list-style-type: none"> <li>• Only operate the components with closed protective cover.</li> </ul>	



	<b>WARNING</b>
<b>Danger to life through electric shock due to missing DC link side covers</b>	
There is a danger of an electric shock through contact when the side covers of the DC link are missing.	
<ul style="list-style-type: none"> <li>• Mount the supplied side covers on the first and last component in the drive line-up. You can order missing side covers (article number: 6SL3162-5AA00-0AA0).</li> </ul>	

 **WARNING****Danger of an accident due to missing warning labels in the national language.**

Missing warning labels in the national language regarding the DC link discharge time can result in death or serious injury.

- Attach the component warning labels in the national language.

 **WARNING****Fire hazard due to overheating because of inadequate ventilation clearances**

Inadequate ventilation clearances can cause overheating with a risk for personnel due to smoke and fire. This can also result in increased failure rates and a shorter service life for Line Modules.

- It is absolutely essential that you maintain ventilation clearances according to the table Ventilation clearances above and below the component (Page 310).

**NOTICE****Material damage due to loose power connections**

Insufficient tightening torques or vibrations can result in faulty electrical connections. This can cause fire damage or malfunctions.

- Tighten all the DC link busbar screws with the specified tightening torques (1.8 Nm tolerance +30 %).
- Check the tightening torques of all power connections at regular intervals and tighten them when required. This applies in particular after transport.

**NOTICE****Material damage due to loose power connections when using the 24 V terminal adapter**

Insufficient tightening torques or vibrations can result in faulty electrical connections. This can cause fire damage or malfunctions.

- When using the 24 V terminal adapter, it must be screwed onto the Control Supply Module Tighten the enclosed EJOT-PT screw K30 x 16 with the specified tightening torque (0.5 Nm).
- Check the tightening torques of all power connections at regular intervals and tighten them when required. This applies in particular after transport.

### 7.1.3 Interface description

#### 7.1.3.1 Overview

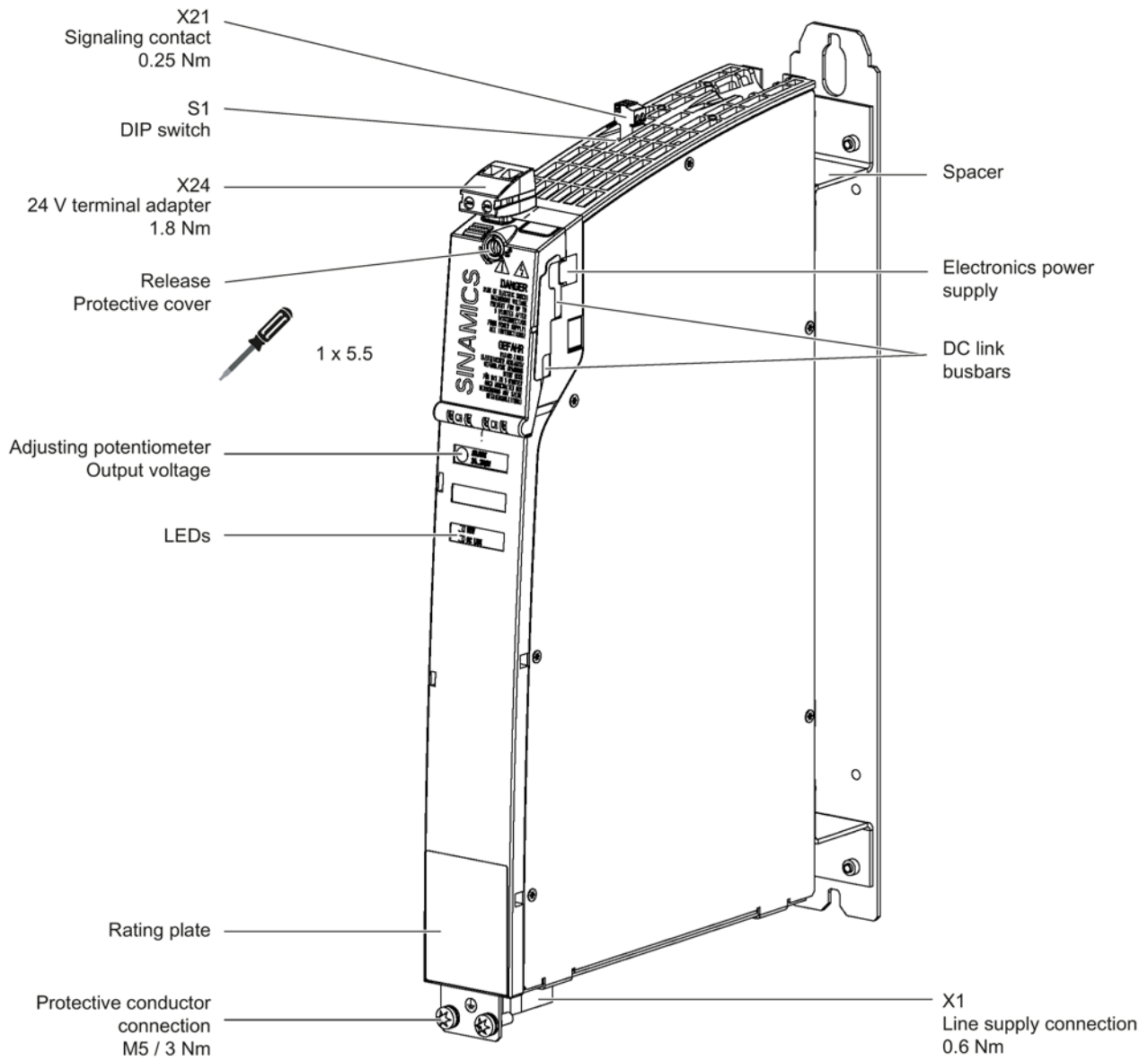
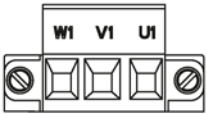
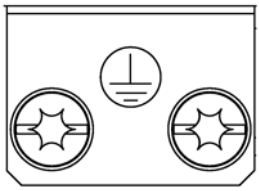

Figure 7-1 Interface overview, Control Supply Module

## 7.1.3.2 X1 line connection

Table 7- 1 X1 line connection

	Terminal	Technical data
	U1	Supply voltage:
	V1	3 AC 380 ... 480 V, 50 / 60 Hz
	W1	Type: Screw terminal 4 (Page 307) Max. connectable cross-section: 4 mm <sup>2</sup> Tightening torque: 0.5 ... 0.6 Nm
	PE connection	Type: M5 screw at the housing Tightening torque: 3 Nm

### 7.1.3.3 X21 signaling contact

Table 7- 2 X21 signaling contact

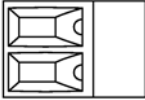
	Terminal	Technical data
	1	Voltage: 24 V DC Max. load current: 0.5 A (ohmic load) Type: Screw terminal 2 (Page 307) Max. connectable cross-section 1.5 mm <sup>2</sup> Tightening torque: 0.22 ... 0.25 Nm
	2	

The 2-pole terminal connector for the signaling contact is included in the Completion Kit provided.

The signaling contact can be wired to a digital input (DI) of the Control Unit to indicate the failure of a Control Supply Module.

The signaling contact operates as an isolated NO contact. When the switch is closed, the Control Supply Module is "OK" and provides the output voltage. The switch opens in the event of a fault "Not OK" – when the overtemperature condition is still present, after a pre-warning, wire breakage, short-circuit etc. The Control Supply Module is correspondingly switched off.

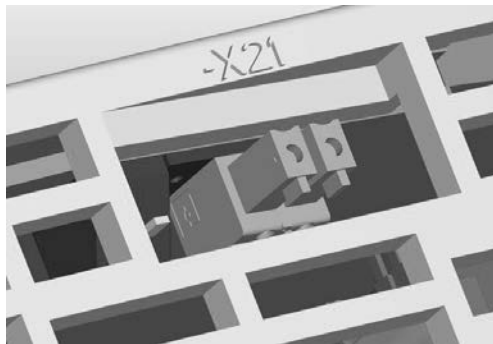

Signaling contact without terminal connector in the delivery condition

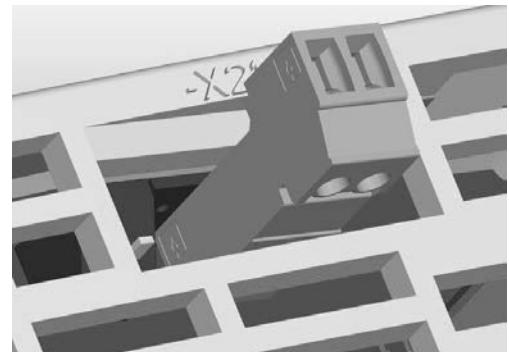

Signaling contact, complete with terminal connector

### 7.1.3.4 X24 24 V terminal adapter

Table 7- 3 X24 24 V terminal adapter

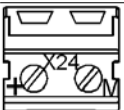
	Terminal	Designation	Technical data
	+	24 V power supply	Supply voltage 24 ... 28.8 V DC Type: Screw terminal 5 (Page 307) Max. connectable cross-section: 6 mm <sup>2</sup> Tightening torque: 1.5 ... 1.8 Nm
	M	Ground	

The 24 V terminal adapter is included in the scope of supply.

### 7.1.3.5 S1 DIP switch

Table 7-4 DIP switch S1

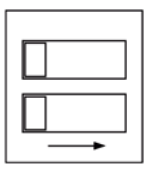
	Terminal	Designation	Technical data
	1	Changeover switch, single operation / parallel operation	Left: Single operation Right: Parallel operation Changing over the output characteristic
	2	Dummy contact (not used)	

It is only permissible to changeover when in the no-voltage state.

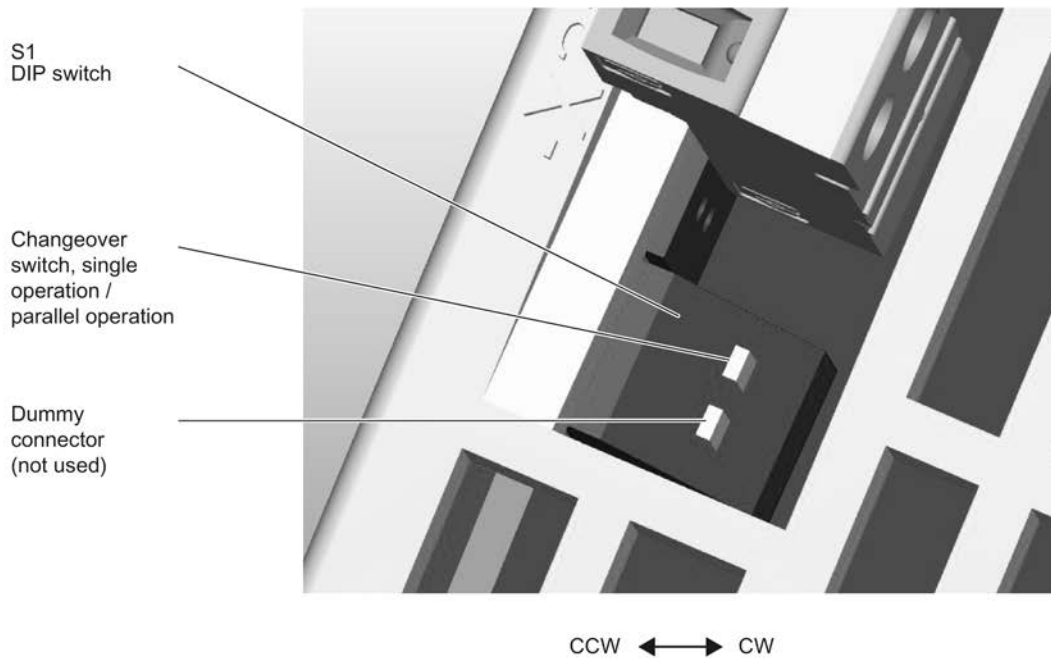

Figure 7-2 DIP switch on the upper side of the component

When delivered, "single operation" is set. Both switches are set to the left.

#### Note

The DIP switch must be set to "single operation" when operating the Control Supply Module on the S120 Combi.

### 7.1.4 Connection example

The control supply module (CSM) is connected to the line supply (3-ph. 380 V AC –10 % to 480 V AC +10 %) via interface X1 (screw terminals 0.2 to 4 mm<sup>2</sup>) This connection should preferably be made without using an isolating device (e.g. contactor).

The CSM has an internal line filter (Class A for TN line supplies), and the pre-charging circuit for the DC link inside the unit is electrically isolated from the 24 V supply.

The CSM also features a current limitation function. When using cables with a cross-section of 2.5 mm<sup>2</sup>, no additional protection is required on the 24 V side if a type XLPE or EPR cable, or a cable with a similar quality and with a minimum thermal stability of up to 90 °C is used.

---

#### Note

If a selectively tripping, AC/DC-sensitive RCCB is used for the drive line-up, the Control Supply Module must always be connected to the line supply downstream of this circuit breaker.

---

#### Note

##### Connecting to the line supply

When configuring the line supply for the Control Supply Module, it should be noted that the CSM must not be connected to the line supply after the S120 Combi has been connected to the line supply. When charging, this prevents the DC link from being immediately loaded by the CSM.

---

The DIP switch must be set to "single operation" to connect the Control Supply Module to the S120 Combi drive line-up. The connection can be established as shown below.

The CSM must be connected to the S120 Combi Power Module and the expansion axes via the DC link busbars as well as also via the 24 V busbars. The red 24 V connector from the accessories pack provided must be inserted under all circumstances.



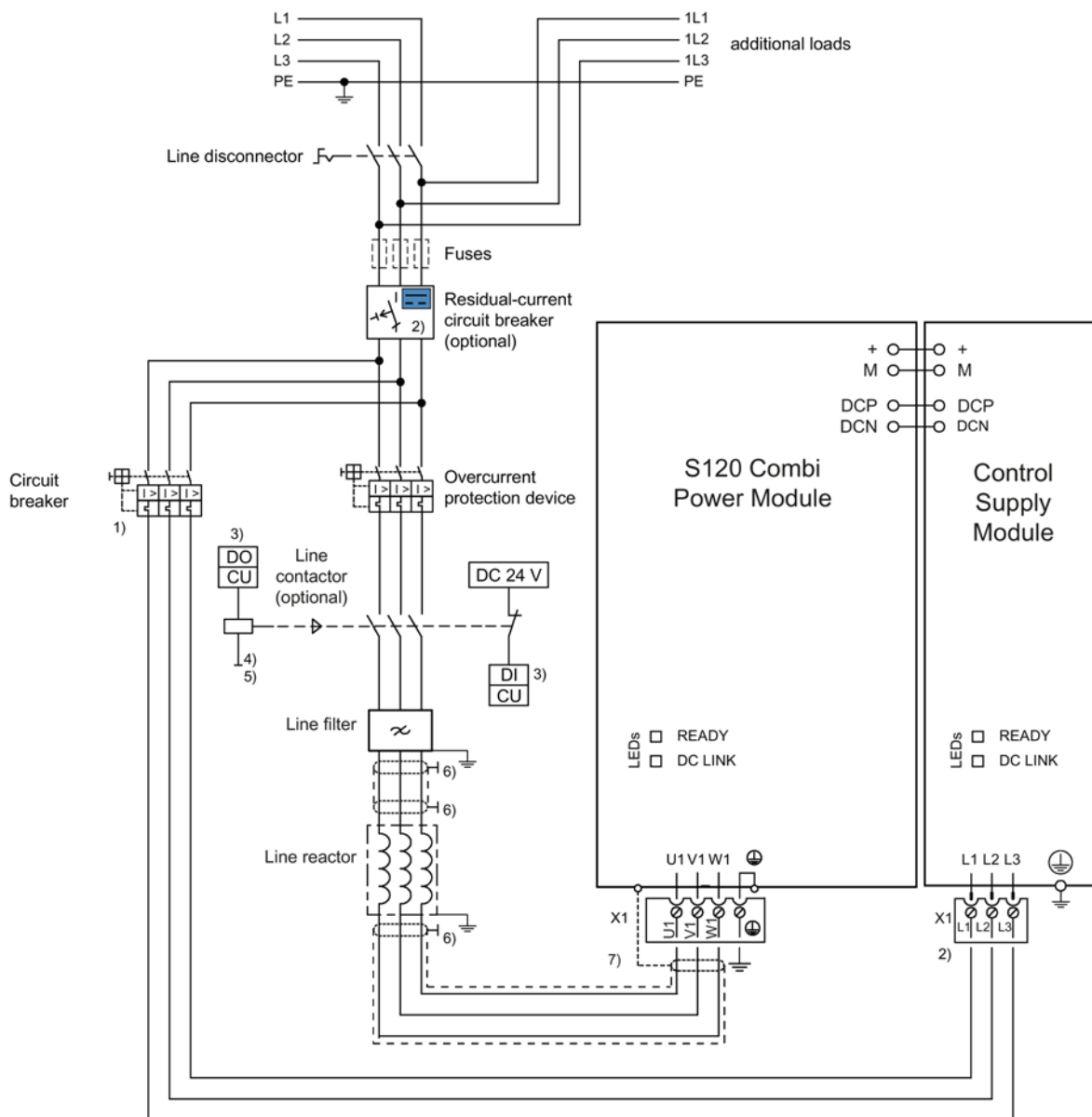

- 1) Permissible types:
  - a) SIRIUS circuit-breaker, 3RV 1021 1DA10, set to 3A
  - b) KTS-R-6-type branch circuit fuse (class RK1)
- 2) The line supply connection must always be available.
- 3) DI/DO, controlled from the Control Unit (SINUMERIK 828D PPU).
- 4) No additional load permitted downstream of the line contactor!
- 5) The current carrying capacity of the DO must be observed; an output coupling device must be used if required.
- 6) Contact established via rear mounting panel or shielding buses in accordance with the EMC installation guideline
- 7) Contact to the cable shield is established through a shield connection clamp

Figure 7-3 Connection example of Control Supply Module CSM in single operation

### 7.1.5 Meaning of the LEDs on the Control Supply Module

Table 7- 5 Meaning of the LEDs on the Control Supply Module

Status		Description, cause	Remedy
<b>RDY</b>	<b>DC LINK</b>		
Off	Off	Electronics power supply outside permissible tolerance range or temperature advance warning active	–
Green	Off	DC input voltage $U_{E\ DC} < 280 \dots 300\ V$ Buffer operation not possible	–
	Yellow	DC input voltage in the range $360 \dots 380\ V < U_{E\ DC} < 820\ V \pm 3\ \%$ Buffer operation possible	–
	Red	DC input voltage outside the tolerance range: $U_{E\ DC} < 360 \dots 380\ V$ or $V_{E\ DC} > 820\ V \pm 3\ \%$	Adjust DC input voltage

### 7.1.6 Dimension drawing

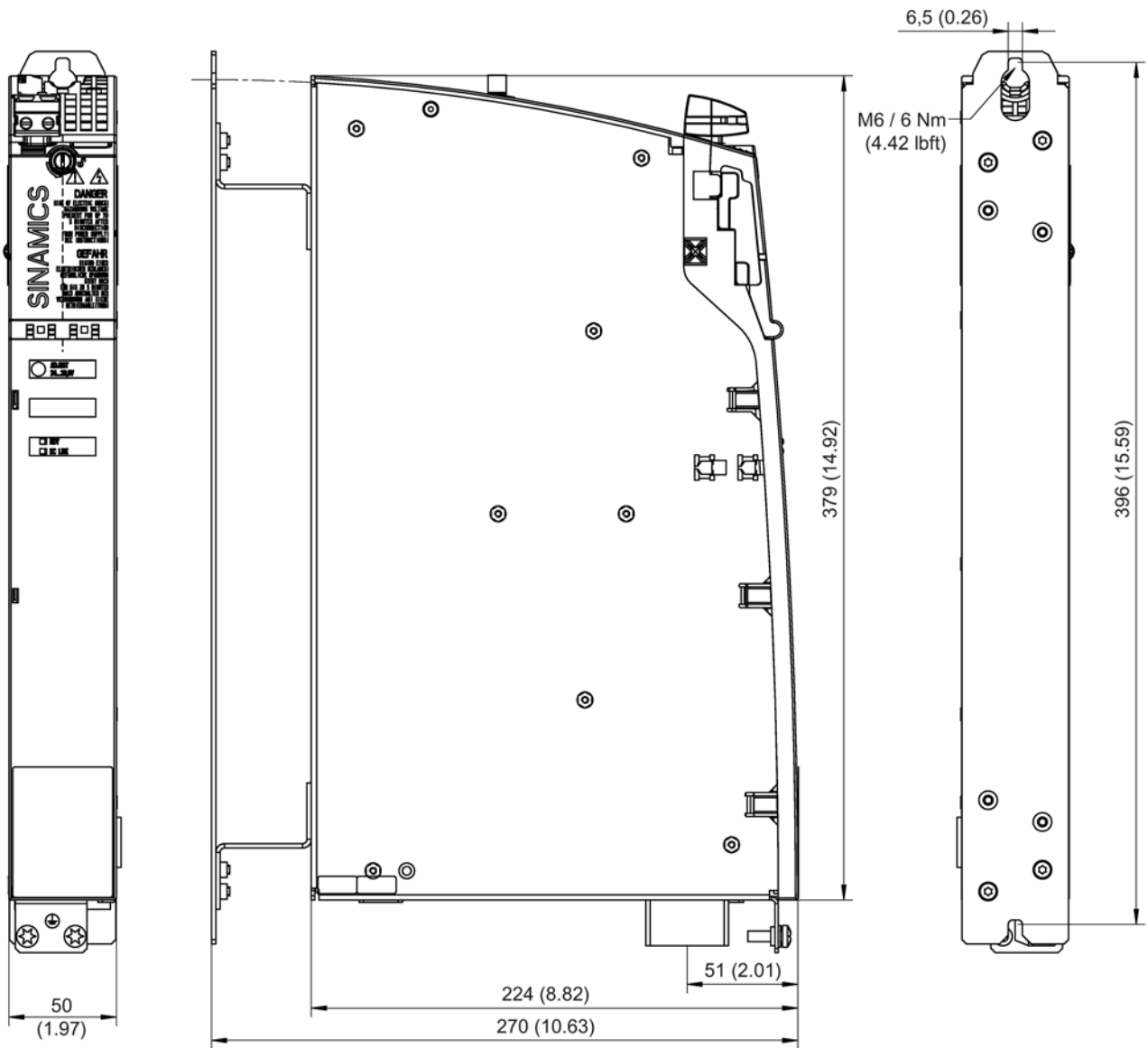
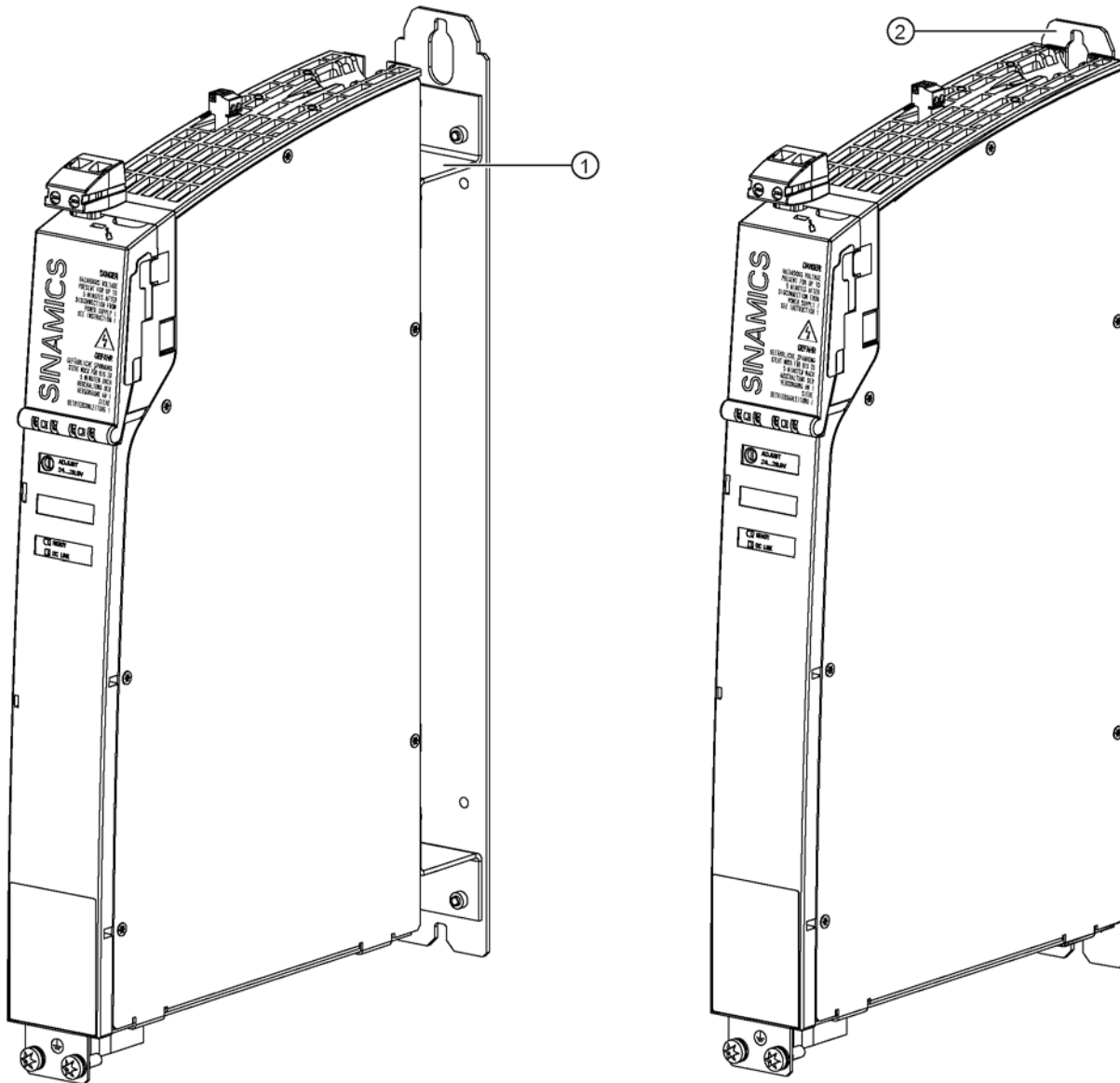

Figure 7-4 Dimension Control Supply Module, all dimensions in mm and (inches)

### 7.1.7 Installation



- ① State when supplied with spacer
- ② Spacer removed - mounting depth for S120 Combi

Figure 7-5 Methods of installing the Control Supply Module with and without spacer

## 7.1.8 Technical data

Table 7- 6 Technical data

6SL3100-1DE22-0AA1	Unit	Value
<b>Input data, AC input</b>		
Line voltage	V <sub>AC</sub>	3 AC 380 ... 480 ± 15 %
Line frequency	Hz	45 ... 66
Rated input current Rated value (at V <sub>E rated</sub> )	A <sub>AC</sub>	≤ 2
Starting current inrush	A <sub>AC</sub>	≤ 28 at > 5 ms
<b>Input data, DC input</b>		
Rated input voltage	V <sub>DC</sub>	600
Input voltage range	V <sub>DC</sub>	300 ... 882
DC link voltage (continuous input voltage)	V <sub>DC</sub>	430 ... 800 300 ... 430 < 1 min 800 ... 853 < 1 min 853 ... 882 < 10 s
Supply current (at 600 V)	A <sub>DC</sub>	1.1
Overvoltage tripping	V <sub>DC</sub>	> 882
Undervoltage tripping	V <sub>DC</sub>	280 ± 3 %
<b>Output data</b>		
Rated output voltage V <sub>A rated</sub>	V <sub>DC</sub>	24 ... 28.8
Rated output current I <sub>A rated</sub> <sup>1)</sup>	A <sub>DC</sub>	20
Rated output power P <sub>A rated</sub>	W	520
Overcurrent limitation for short-circuit	A <sub>DC</sub>	approx. 23
Surge suppression	V	< 35
Current carrying capacity of the 24 V busbar	A <sub>DC</sub>	20
Residual ripple (clock frequency approx. 50 kHz)	mV <sub>pp</sub>	< 100
Switching peaks (bandwidth 20 MHz)	mV <sub>pp</sub>	< 200
Power loss ride-through (at 400 V AC)	ms	5
<b>Power loss</b>		
Line	W	70
DC link	W	65
(see Power loss tables (Page 316))		
<b>Efficiency</b>	%	> 83
<b>circuit breaker (UL)<sup>2)</sup></b> Type designation:		listed NKJH: 3RV1021-1DA10 3RV2011-1DA.. 3RV2021-1DA..
Rated current:	A	2.2 ... 3.2 (set value 3.2)
		listed DIVQ: 3RV2711-4AD..
		15
<b>Fuses (UL)</b>		
Class RK1, J, CC, CF		
Rated current:	A	6
Operating voltage:	V <sub>AC</sub>	≥ 480

6SL3100-1DE22-0AA1	Unit	Value
Cooling method		Internal air cooling
Weight	kg	4.8

- 1) Above 40° C, a linear derating of the output current above a 26 V output voltage and higher must be observed
- 2) When using circuit breakers for protection, UL approval is only possible in TN/TT line systems with grounded neutral point. Conventional fuses are required for UL approval in line supplies with grounded line conductor.

### 7.1.8.1 Characteristics

#### Derating characteristic

For ambient temperatures > 40 °C, a linear derating for the output current must be observed as of 26 output voltage.

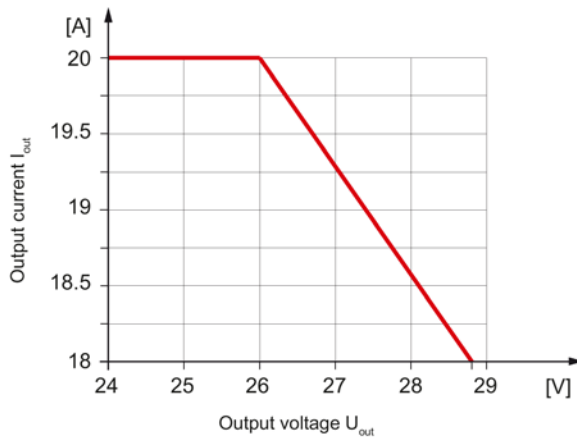

Figure 7-6 Current derating for ambient temperatures >40 °C as a function of the output voltage

## 7.2 Braking Module Booksize

### 7.2.1 Description

The Braking Module is used together with an external braking resistor for the following applications:

- For a power failure, the S120 Combi and expansion axes can be stopped in a controlled fashion (e.g. emergency retraction or EMERGENCY OFF Category 1).
- For brief generator operation, the DC link voltage can be limited, e.g. if the energy recovery function is deactivated or is not adequately dimensioned.

The Braking Module includes the necessary power electronics and control. When the Braking Module is in operation, the power which is fed back into the DC link is dissipated via an external braking resistor.

### External braking resistors

On the Braking Module, braking resistors can be operated without thermostatic switches 6SN1113-1AA00-0DA0 ( $P_N = 0.3$  kW) and 6SL3100-1BE31-0AA0 ( $P_N = 1.5$  kW).

The cable length between the Braking Module and the braking resistor is limited to a maximum of 10 m.

A shielded connection cable (3 m, 3 x 1.5 mm<sup>2</sup>) is supplied with braking resistor 6SN1113-1AA00-0DA0.

## Rapid discharge

Furthermore, the Braking Module can be used with a braking resistor to quickly discharge the DC link capacitors. The DC link is discharged in a controlled manner via the braking resistor once the infeed unit has been switched off and the line-up has been disconnected from the line supply (e.g. via the main switch or line contactor). The function can be activated via a digital input on the braking module. A quick discharge makes sense, for example, when maintenance tasks are to be performed at the S120 Combi and/or motor installation (reduction of the discharge time).



<b>⚠ WARNING</b>
<b>Danger to life when live parts are touched after rapid discharge</b>
After rapid discharge or if discharge is interrupted, a hazardous voltage can still remain.
Death or serious injury can result when live parts are touched.
<ul style="list-style-type: none"><li>• Check that it really is in a no-voltage condition, from phase conductor to phase conductor and phase conductor to protective conductor.</li></ul>

<b>NOTICE</b>
<b>Material damage during fast discharge due to overvoltages</b>
Existing voltages can damage the rapid discharge system.
<ul style="list-style-type: none"><li>• Fully disconnect the drive system for rapid discharge from the line supply.</li><li>• The motors must be at a standstill.</li></ul>

## Monitoring functions

- Automatic detection of braking resistors and braking power monitoring
- I<sup>2</sup>t monitoring of the braking resistors
- Temperature monitoring of the Braking Module
- Short circuit and overload detection
- Ground fault detection



## 7.2.2 Safety information

 **WARNING****Danger to life if the fundamental safety instructions and remaining risks are not carefully observed**

If the fundamental safety instructions and remaining risks in Chapter 1 (Page 21) are not observed, accidents involving severe injuries or death may occur.

- Adhere to the fundamental safety instructions.
- When assessing the risk, take into account residual risks.

 **DANGER****Danger to life through electric shock due to the residual charge of the DC link capacitors**

Due to the DC link capacitors, a hazardous voltage is present in the DC link for up to five minutes after the power supply has been switched off.

Contact with live parts can result in death or serious injury.

- Do not open the protective cover of the DC link until five minutes have elapsed.
- Only operate the S120 Combi with the DC link protective cover closed.
- Do not continue to operate damaged components.

 **WARNING****Danger of an accident due to missing warning labels in the national language.**

Missing warning labels in the national language regarding the DC link discharge time can result in death or serious injury.

- Attach the component warning labels in the national language.

 **WARNING****Fire hazard due to overheating because of inadequate ventilation clearances**

Inadequate ventilation clearances can cause overheating with a risk for personnel through smoke development and fire. This can also result in more downtimes and Line Modules may have a reduced service life.

- It is absolutely essential that you maintain ventilation clearances according to the table Ventilation clearances above and below the component (Page 310).

 **WARNING****Danger to life through electric shock due to missing DC link side covers**

There is a danger of an electric shock through contact when the side covers of the DC link are missing.

- Mount the supplied side covers on the first and last component in the drive line-up.  
You can order missing side covers (article number: 6SL3162-5AA00-0AA0).

**NOTICE**

**Material damage due to loose power connections**

Insufficient tightening torques or vibrations can result in faulty electrical connections. This can cause fire damage or malfunctions.

- Tighten all the DC link busbar screws with the specified tightening torques (1.8 Nm tolerance +30 %).
- Check the tightening torques of all power connections at regular intervals and tighten them when required. This applies in particular after transport.

---

**Note**

If braking resistors other than those described in Section Braking resistors (Page 188) (6SN1113-1AA00-0DA0 and 6SL3100-01BE31-0AA) are used then these could be destroyed.

---

## 7.2.3 Interface description

### 7.2.3.1 Overview

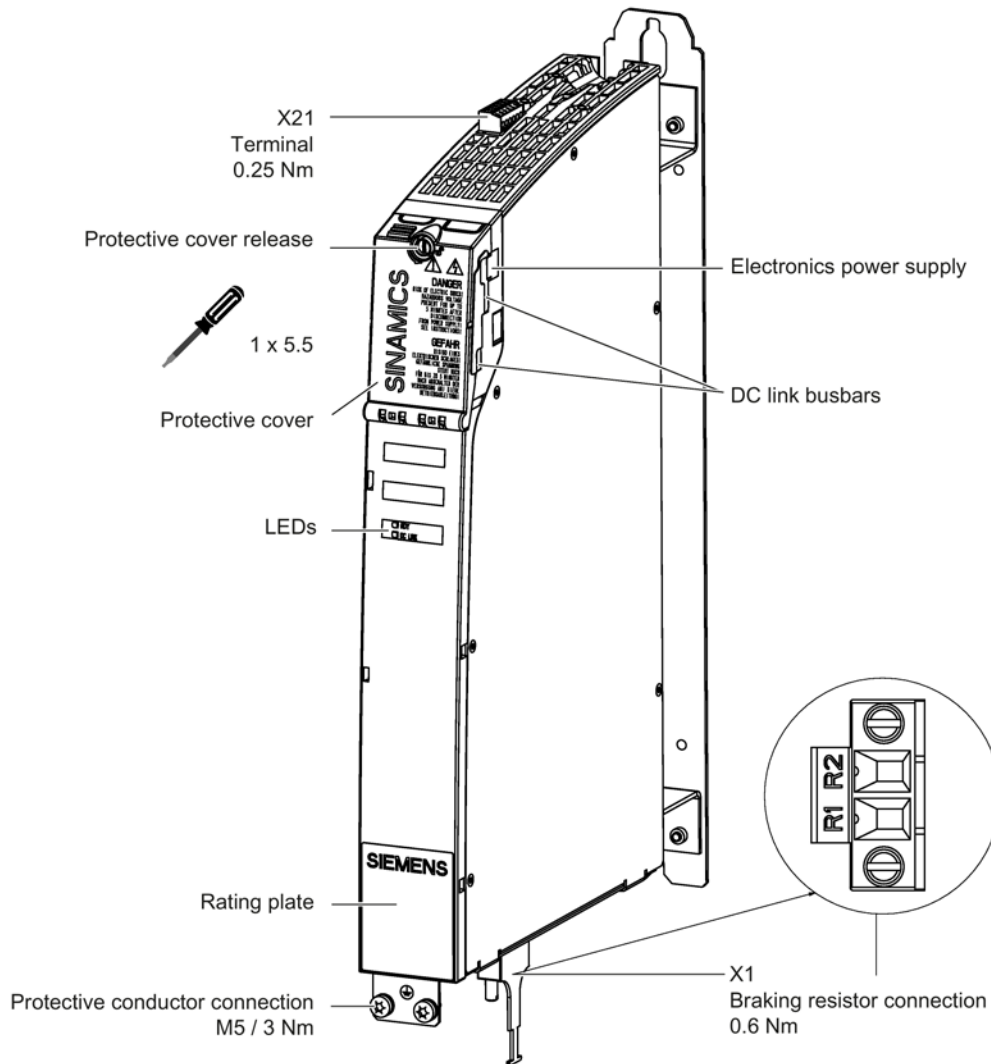

Figure 7-7 Interface overview, Braking Module Booksize

## 7.2.3.2 X1 braking resistor connection

Table 7- 7 X1 braking resistor connection

	Terminal	Designation	Technical data
	1	Braking resistor connection R1	Continuously short-circuit proof Type: Screw terminal 4 (Page 307) Max. connectable cross-section: 4 mm <sup>2</sup> Tightening torque: 0.5 ... 0.6 Nm
	2	Braking resistor connection R2	

Table 7- 8 Braking resistors without a thermostatic switch for Braking Modules

Braking resistor	R in $\Omega$	P <sub>N</sub> in kW	P <sub>max</sub> in kW
6SN1113-1AA00-0DA0	17	0.3	25
6SL3100-1BE31-0AA0	5.2	1.5	100

**Note**

For detailed technical information on the braking resistors, see the section entitled Braking resistors (Page 188).

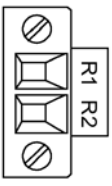
### 7.2.3.3 X21 digital inputs/outputs

Table 7-9 X21 digital inputs/outputs

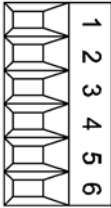
	Terminal	Designation <sup>1)</sup>	Technical data
	1	DI low: enable Braking Module DI high: Inhibit/acknowledge Edge change, high → low: fault acknowledgement	Voltage: -3 ... +30 V Current consumption typical: 10 mA at 24 V DC
	2	DI low: braking resistor not activated manually DI high: Braking resistor controlled manually (quick discharge) <sup>2)</sup>  If X21.1 and X21.2 are activated simultaneously, the Braking Module inhibit has priority.	Level (incl. ripple) High level: 15 ... 30 V Low-level: -3 ... +5 V
	3	DO high: no prewarning DO low: Prewarning, disconnection imminent	Max. load current per output: 100 mA Continuously short-circuit proof
	4	DO high: ready for operation, no fault DO low: Fault (1→0)	Voltage: 24 V DC
	5	Ground	
	6		
			Type: Screw terminal 1 (Page 307) Max. connectable cross-section 1.5 mm <sup>2</sup> Tightening torque: 0.22 ... 0.25 Nm

<sup>1)</sup> DI: digital input; DO: digital output; M: Electronics ground

<sup>2)</sup> The fast discharge function is used for discharging the capacitors in the DC link after interruption of the line supply and may be used a maximum of 1 to 2 times per week.

#### Terminal X21.1 - inhibit/acknowledge

Applying a high signal to terminal X21.1 inhibits the Braking Module. On a falling edge, pending error signals are acknowledged.

#### Terminal X21.3 - prewarning

When a prewarning is sent, disconnection of the braking module is imminent.

This may be due to the following causes:

- The temperature of the Braking Module is 80 % of the maximum value.
- 80 % of the maximum on-load factor of the braking resistor has been reached (I<sup>2t</sup> monitoring).
- 80 % of the maximum braking energy of the braking resistor has been reached.
- An incorrect braking resistor is connected (only braking resistors approved by Siemens for this component are identified automatically).

#### Terminal X21.4 - fault

In the event of an overtemperature, the error cannot be acknowledged until after a cooling phase.

### 7.2.4 Connection example

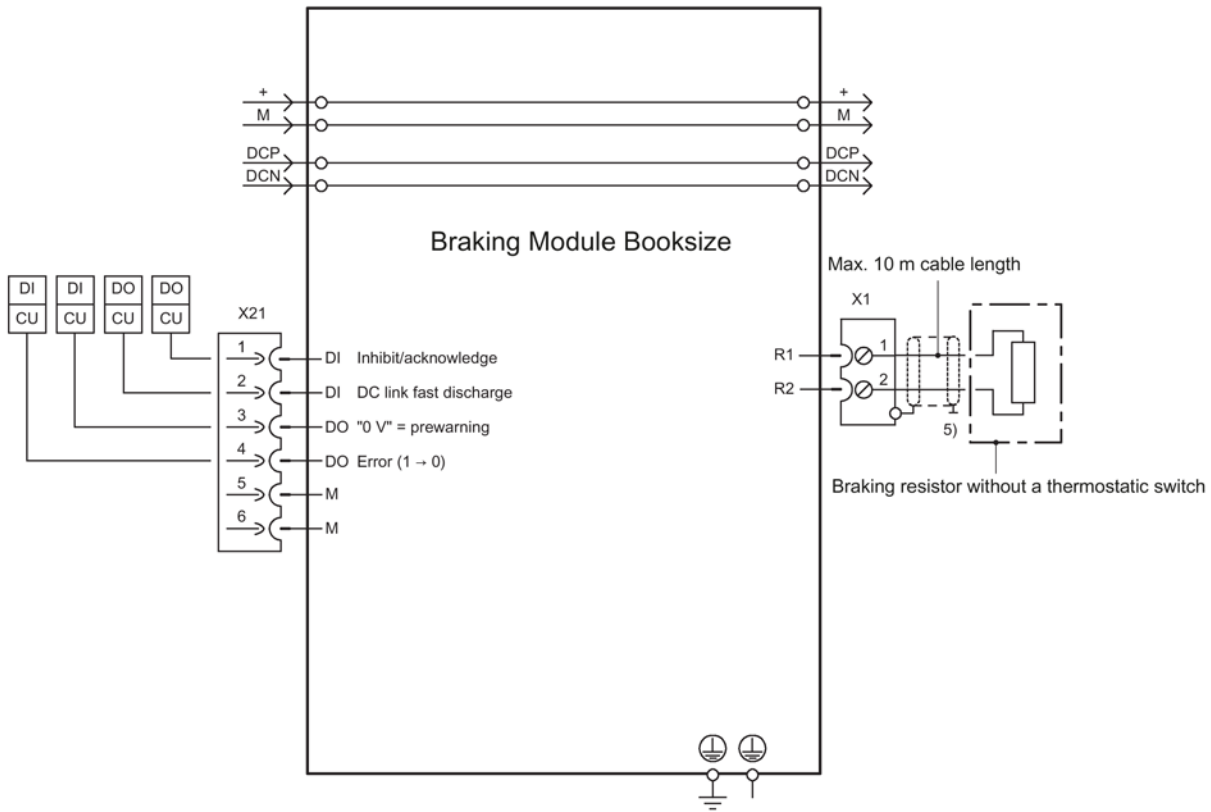

Figure 7-8 Connection example of a Braking Module Booksize

Information on how to parameterize the digital inputs or digital outputs, see the SINAMICS S120/S150 List Manual.

## 7.2.5 Meaning of the LEDs

Table 7- 10 Meaning of the LEDs on the Braking Module Booksize

Status		Description, cause	Remedy
RDY	DC LINK		
Off	Off	Electronics power supply is missing or outside the permissible tolerance range. Component not active or has been deactivated via the terminal.	–
Green	Off	Component is ready for operation. Electronics power supply is missing or outside the permissible tolerance range. Component not active.	–
	Green flashing light	Component active (DC link discharge via braking resistor in progress).	–
Red	Off	Approval missing (input terminal) Overtemperature Overcurrent trip I <sup>2</sup> t-monitoring activated Ground fault/short circuit <b>Note:</b> In the event of overtemperature, the error cannot be acknowledged until after a cooling phase.	Diagnose fault (via output terminals) and acknowledge it (via input terminal)

7.2.6 Dimension drawing

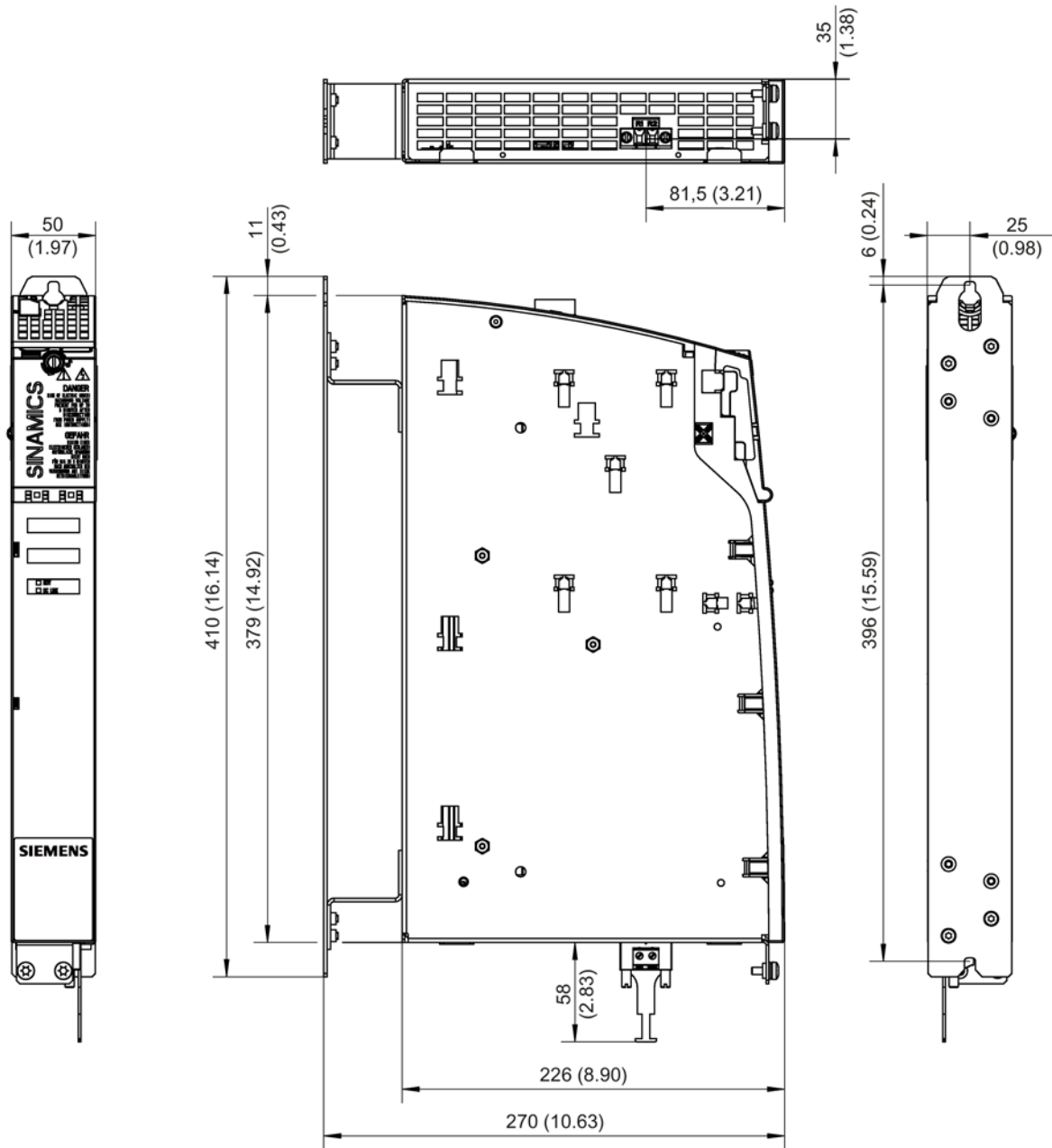
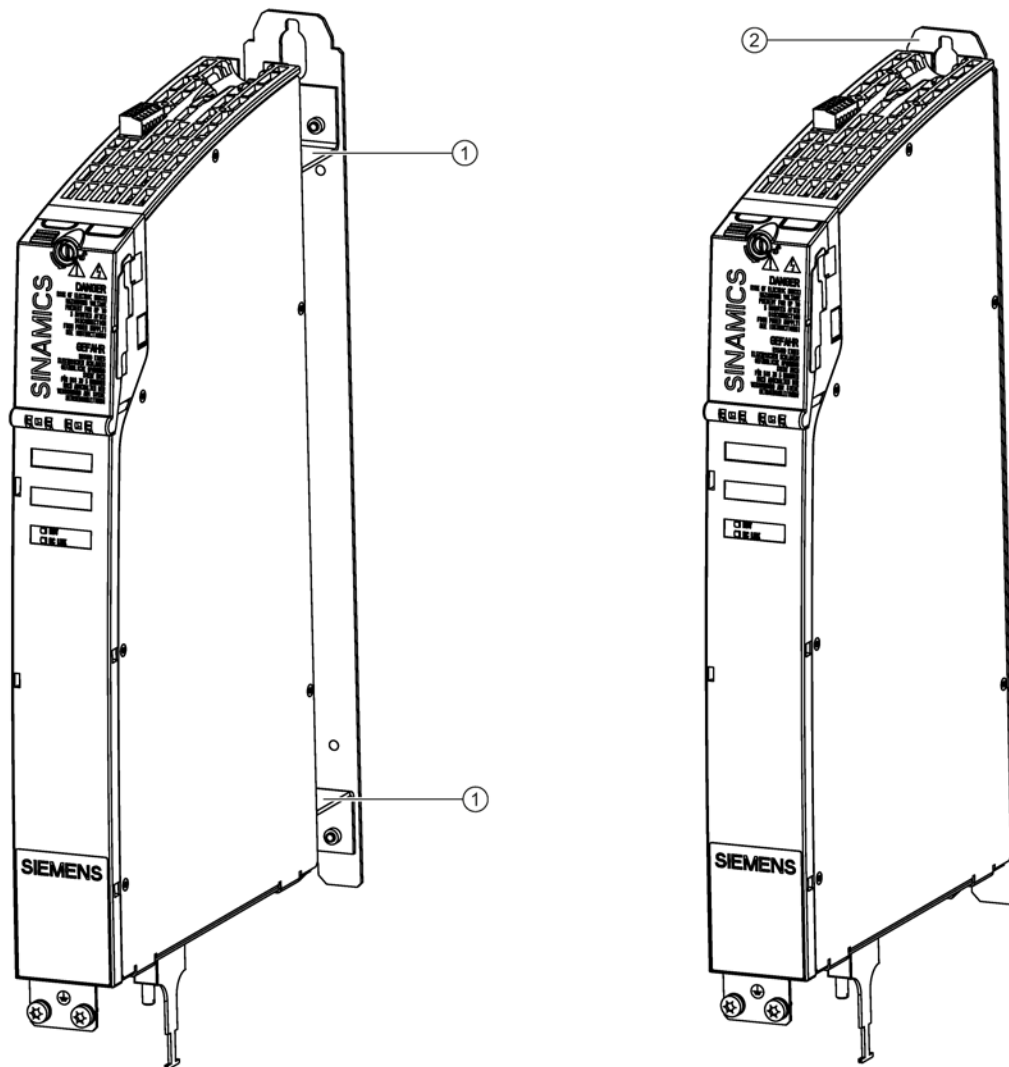

Figure 7-9 Dimension drawing of Braking Module, all dimensions in mm and (inches)



## 7.2.7 Installation



- ① State when supplied with spacer
- ② Spacer removed - mounting depth for S120 Combi

Figure 7-10 Methods of installing Braking Modules with/without spacer elements

## 7.2.8 Technical data

Table 7- 11 Technical data

<b>6SL3100-1AE31-0AB.</b>		
DC link voltage	V <sub>DC</sub>	510 ... 720
DC link capacitance	μF	110
ON threshold	V	770
Electronics power supply	V <sub>DC</sub>	24 (20.4 ... 28.8)
Electronics current drawn (at 24 V DC)	A <sub>DC</sub>	0.5
<b>Current carrying capacity</b>		
DC link busbars	A <sub>DC</sub>	100
24 V busbars	A <sub>DC</sub>	20
<b>Braking power</b>		
Max.	kW	100
Continuous braking power	kW	1.5
Power loss (see power loss tables (Page 316))	W	20
Cooling method		Natural convection
Weight	kg	4.1

### 7.2.8.1 Characteristic curves

#### Duty cycle for braking resistors without a thermostatic switch

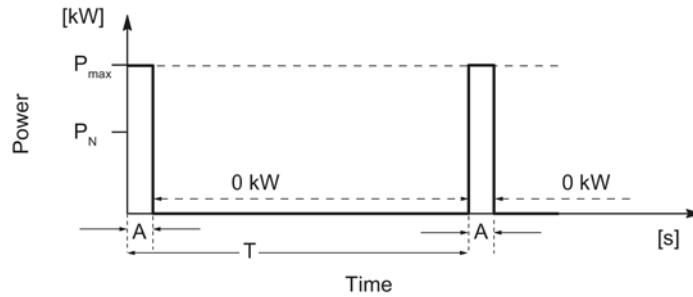

Figure 7-11 Duty cycle for braking resistors without a thermostatic switch

$T$  [s] time period of braking duty cycle

$A$  [s] load duration

$P_N$  [W] rated power (continuous power) of braking resistor

$P_{max}$  [W] peak power of braking resistor ( $6 \times P_N$ )

Table 7- 12 Duty cycles

	6SN1113-1AA00-0DA0		6SL3100-1BE31-0AA.	
	Short duty cycle	Long duty cycle	Short duty cycle	Long duty cycle
A [s]	0.1	0.4	1	2
T [s]	11.5	210	68	460

**The following applies when connecting Braking Modules in parallel:**

$P_{N\text{ total}} = 0.9 \times \text{total } P_N \text{ of single devices}$

$P_{max\text{ total}} = \text{total } P_{max} \text{ of single devices}$

## 7.3 Braking resistors

### 7.3.1 Description

A braking resistor is used to dissipate the excess DC link energy in generator operation. One braking resistor is connected to one Braking Module.

Resistors without thermostatic switch are available with various power ratings.

### Installation

The braking resistors can be installed standing on the floor of the control cabinet or suspended. You must ensure that the braking resistors do not obstruct the flow of cooling air to the drive line-up.

Positioning the braking resistor outside the control cabinet or switchgear room enables the resulting thermal losses to be routed away. This reduces the level of air conditioning required.

### Connecting cables

A shielded connection cable (3 m, 3 x 1.5 mm<sup>2</sup>) is supplied with braking resistor 6SN1113-1AA00-0DA0.

Other braking resistors are supplied without connecting cable. The maximum conductor cross-sections are listed in the technical data.

The maximum cable length for all braking resistors is 10 m.

## 7.3.2 Safety information

 **WARNING****Danger to life if the fundamental safety instructions and remaining risks are not carefully observed**

If the fundamental safety instructions and remaining risks in Chapter 1 (Page 21) are not observed, accidents involving severe injuries or death may occur.

- Adhere to the fundamental safety instructions.
- When assessing the risk, take into account residual risks.

 **WARNING****Fire hazard and device damage as a result of ground fault/short-circuit**

The cables to the braking resistor must be routed so that a ground fault or short-circuit can be ruled out. A ground fault can result in fire with associated smoke.

- Comply with local installation regulations that enable this fault to be ruled out.
- Protect the cables from mechanical damage.
- In addition, apply one of the following measures:
  - Use cables with double insulation.
  - Maintain adequate clearance, e.g. using spacers.
  - Route the cables in separate cable ducts or pipes.

 **CAUTION****Risk of burns resulting from high surface temperatures**

The braking resistor can become very hot. You can be severely burnt when touching the surface.

- Mount the braking resistor so that it cannot be touched. If this is not possible, attach a clearly visible and understandable warning notice at hazardous positions.
- To prevent adjacent components from suffering damage due to these high temperatures, maintain a clearance of 100 mm on all sides of the braking resistor.

### 7.3.3 Dimension drawings

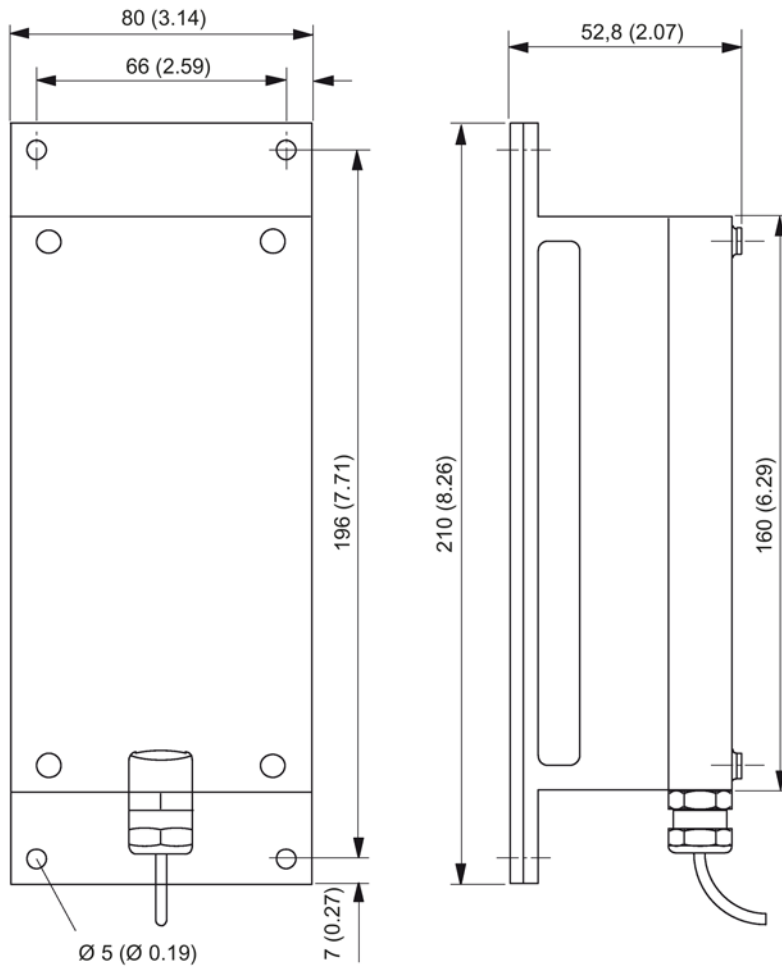

Figure 7-12 Dimension drawing of braking resistor 0.3 kW/25 kW, all dimensions in mm and (inches)

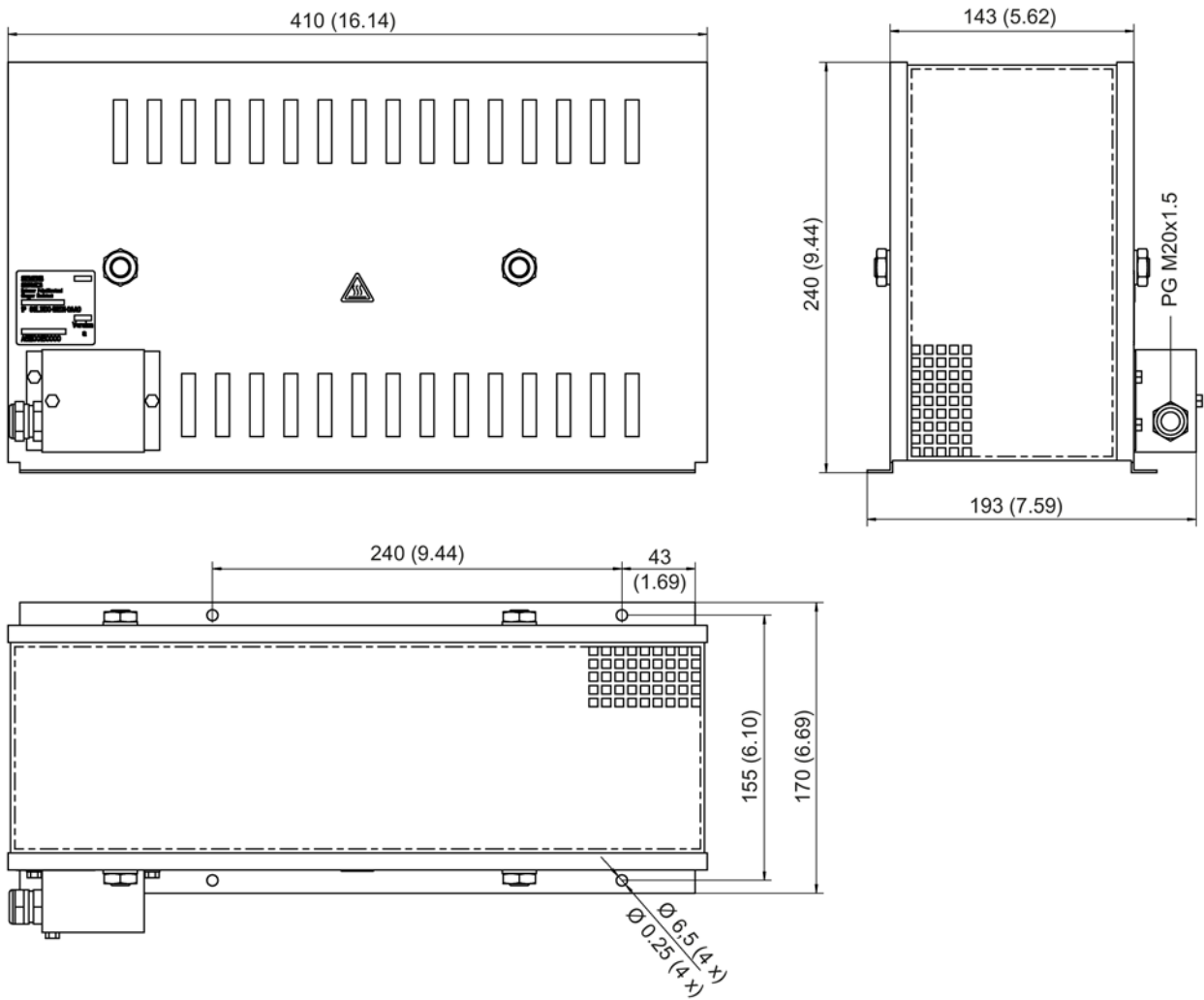

Figure 7-13 Dimension drawing of braking resistor 1.5 kW/100 kW, all dimensions in mm and (inches)

### 7.3.4 Technical data

Table 7- 13 Technical data for braking resistors that have no thermostatic switch

	Unit	6SN1113-1AA00-0DA0	6SL3100-1BE31-0AA.
Resistance R	$\Omega$	17	5.7
Rated power $P_n$	kW	0.3	1.5
Peak power $P_{max}$	kW	25	100
Max. energy consumption $E_{max}$	kWs	7.5	200
Power cable connection		Included in scope of delivery; length 3 m, 3 x 1.5 mm <sup>2</sup>	Screw terminal <sup>1)</sup> , 4 mm <sup>2</sup>
Weight	kg	3.4	5.6
Dimensions (W x H x D)	mm	80 x 210 x 53	193 x 410 x 240
Degree of protection according to EN 60529		IP54	IP20

<sup>1)</sup> The MC500 or MC800 motor cable should be used as connecting cable.

#### Duty cycle

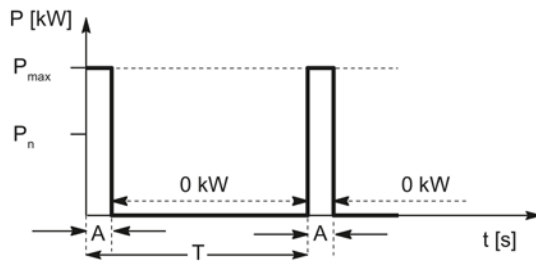

Figure 7-14 Duty cycle for braking resistors

T [s] period duration of braking duty cycle

A [s] load duration

$P_n$  [W] continuous braking power of braking resistor

$P_{max}$  [W] peak braking power of the braking resistor

Table 7- 14 Duty cycles for Braking Module Booksize

	6SN1113-1AA00-0DA0		6SL3100-1BE31-0AA.	
	Short duty cycle	Long duty cycle	Short duty cycle	Long duty cycle
A [s]	0.1	0.4	1	2
T [s]	11.5	210	68	460



# Electrically connecting Motor Modules and DC link components

# 8

## 8.1 Introduction

The S120 Combi offers the possibility of connecting the following expansion axes and DC link components to the DC link and the 24 V electronics power supply:

- Motor Modules Booksize Compact
- Braking Module
- Control Supply Module

For the S120 Combi, the DC link connection and the 24 V busbars are located at the front behind the front plate. Signal and power cables from the additional components should be connected according to the Sections Motor Modules Booksize Compact as expansion axes (Page 139) and DC link components (Page 161).

## 8.2 Removing the front cover and opening the DC link cover on the S120 Combi

To electrically connect additional components, the front cover of the S120 Combi must be removed. The DC link busbars are located under the DC link cover.

**Tool:**

Torx T20 or slotted 1.2 x 6 screwdriver



**! DANGER**

**Danger to life through electric shock due to residual charge**

A hazardous voltage is still present for up to 5 minutes after the power supply has been switched off.

Contact with live parts can result in death or serious injury.

- Remove the front plate only after 5 minutes have passed.
- Check that it really is in a no-voltage condition, from phase conductor to phase conductor and phase conductor to protective conductor.
- Check that the DC link is in a no-voltage condition.

8.2 Removing the front cover and opening the DC link cover on the S120 Combi

If required, remove the drip protection grid.



Remove the two Torx-slotted screws at the front.



Release the front cover by slightly pressing upwards



Remove the front plate.

Remove the Torx-slotted screw of the DC link cover.



Remove the DC link cover.



Remove the DC link side cover.

### 8.3 Connection of DC link busbars and 24 V busbars

The following steps are necessary to connect a component to the DC link and the 24 V busbars of the S120 Combi:

1. Use a suitable screwdriver or tool from the accessories pack to open the protective cover of the component which is to be connected.
2. Remove the DC link side cover at the connection location.

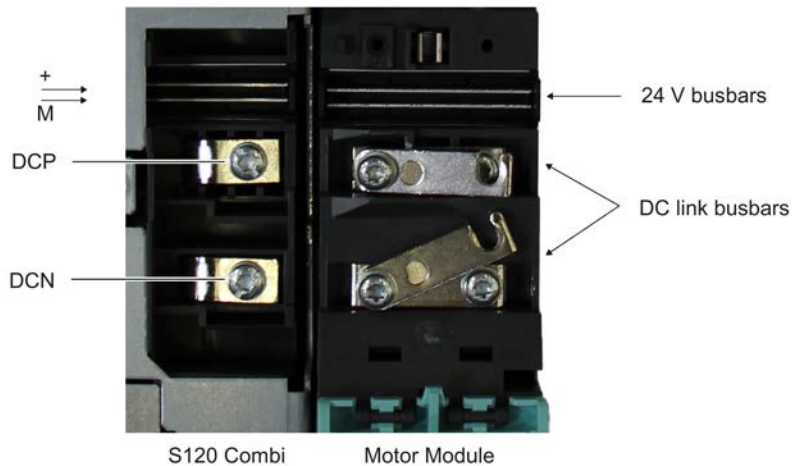



Figure 8-1 S120 Combi and Motor Module without DC link covers

3. Install the lower and upper DC link busbars.

Install the lower DC link busbar	Install the upper DC link busbar
	
<ul style="list-style-type: none"> <li>• Release the screws.</li> <li>• Turn over the DC link bridge.</li> <li>• Observe the following sequence when screwing into place.</li> </ul>	<ul style="list-style-type: none"> <li>• Release the screws.</li> <li>• Turn over the DC link bridge.</li> <li>• Observe the following sequence when screwing into place.</li> </ul>
<b>Screwdriver</b>	Torx T20 or slotted 1.2 x 6
<b>Tightening torque</b>	1.8 Nm

4. Install the 24 V connector (accessories pack of the component to be connected).

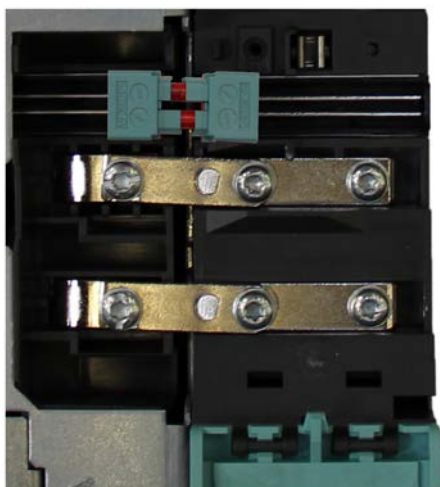

Figure 8-2 S120 Combi and Motor Module with installed 24 V connector

5. Close the protective cover of the connected component.

6. Mount the front plate on the S120 Combi.



**! DANGER**

**Danger to life due to electric shock in the event of missing touch protection**

Death or serious injury can result when live parts are touched.

- After removing the additional components, before recommissioning the system, you must reinstall the lateral DC link cover on the S120 Combi Power Module. The DC link lateral cover can be ordered as a spare part (order number: 6SL3161-3AP00-0AA0).



**! WARNING**

**Danger to life through electric shock due to missing DC link side covers, protective cover or front plate**

There is a danger of an electric shock through contact when the side covers, protective cover or front plate of the DC link are missing.

- Mount the supplied side covers on the first and last component in the drive line-up.  
You can order missing side covers (article number: 6SL3162-5AA00-0AA0).
- Close the protective cover of the connected component.
- Mount the front plate on the S120 Combi.



**! WARNING**

**Danger to life due to electric shock when connecting and disconnecting 24 V connections in operation**

When opening plug connections in operation, arcs can result in severe injury or death.

- Only withdraw or insert the 24 V connectors in a no-voltage state.
- It is only permissible to withdraw or insert the 24 V connectors a maximum of 5 times.

## 8.4 Connecting an additional component

An additional component is connected as follows to the DC link busbars and the 24 V busbars:

1. Use a suitable screwdriver or tool from the accessories pack to open the protective cover of the component which is to be connected.
2. Remove the DC link side covers of both components at the connection location

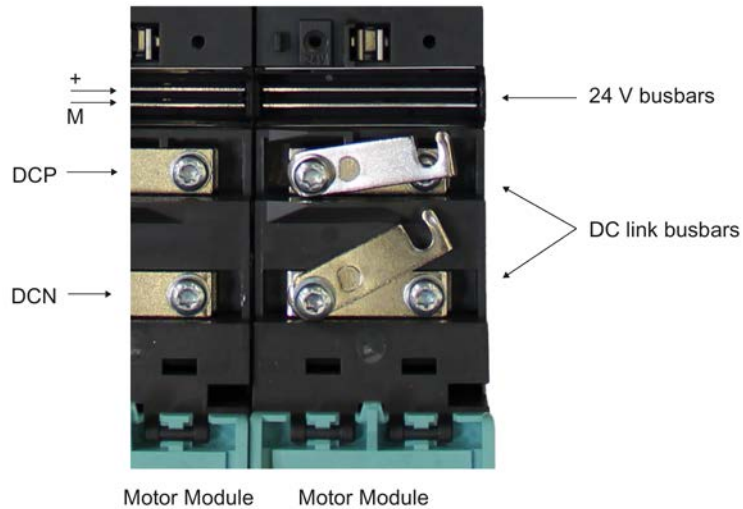



Figure 8-3 Prepared Motor Modules to connect the DC link busbars

8.4 Connecting an additional component

3. Install the lower and upper DC link busbars.

Install the lower DC link busbar	Install the upper DC link busbar
	
<ul style="list-style-type: none"> <li>• Release the screws.</li> <li>• Turn over the DC link bridge.</li> <li>• Observe the following sequence when screwing into place.</li> </ul>	<ul style="list-style-type: none"> <li>• Release the screws.</li> <li>• Turn over the DC link bridge.</li> <li>• Observe the following sequence when screwing into place.</li> </ul>
<b>Screwdriver</b>	Torx T20 or slotted 1.2 x 6
<b>Tightening torque</b>	1.8 Nm

4. Install the 24 V connector (accessories pack of the component to be connected).



Figure 8-4 Motor Modules with 24 V connector installed

5. Close the protective covers of both components.





**! DANGER**

**Danger to life due to electric shock in the event of missing touch protection**

Death or serious injury can result when live parts are touched.

- After removing the additional components, before recommissioning the system, you must reinstall the lateral DC link cover on the S120 Combi Power Module. The DC link lateral cover can be ordered as a spare part (order number: 6SL3161-3AP00-0AA0).



**! WARNING**

**Danger to life through electric shock due to missing DC link side covers, protective cover or front plate**

There is a danger of an electric shock through contact when the side covers, protective cover or front plate of the DC link are missing.

- Mount the supplied side covers on the first and last component in the drive line-up. You can order missing side covers (article number: 6SL3162-5AA00-0AA0).
- Close the protective cover of the connected component.
- Mount the front plate on the S120 Combi.



**! WARNING**

**Danger to life due to electric shock when connecting and disconnecting 24 V connections in operation**

When opening plug connections in operation, arcs can result in severe injury or death.

- Only withdraw or insert the 24 V connectors in a no-voltage state.
- It is only permissible to withdraw or insert the 24 V connectors a maximum of 5 times.



## Additional system components

### 9.1 Terminal Module TM54F

#### 9.1.1 Description

The Terminal Module TM54F is a terminal expansion module for snapping onto an EN 60715 DIN rail. The TM54F offers safe digital inputs and outputs for controlling SINAMICS Safety Integrated functions.

The TM54F must be directly connected to the PPU of SINUMERIK 828D via DRIVE-CLiQ. In so doing, the topology rules must be observed.

TM54F features the following interfaces:

Table 9- 1 Interface overview of the TM54F

Type	Number
DRIVE-CLiQ interfaces	2
Fail-safe digital outputs (F-DO)	4
Fail-safe digital inputs (F-DI)	10
Sensor <sup>1)</sup> power supplies, dynamization supported <sup>2)</sup>	2
Sensor <sup>1)</sup> power supply, no dynamization	1
Digital inputs for testing the F-DO at test stop	4

<sup>1)</sup> Sensors: Fail-safe devices to issue commands and sense - for example, Emergency Stop buttons and safety locks, position switches and light arrays/light curtains.

<sup>2)</sup> Forced checking procedure: The sensor power supply is cycled on and off by the TM54F when the forced checking procedure is active for the sensors, cable routing, and the evaluation electronics.

The TM54F has 4 fail-safe digital outputs and 10 fail-safe digital inputs.

A fail-safe digital output comprises:

- An output switching to 24 V
- An output switching to ground
- Digital input to check the switching state

A fail-safe digital input comprises:

- 2 digital inputs

---

**Note**

The rated values of the F-DO meet the requirements of EN 61131-2 for digital DC outputs with 0.5 A rated current.

The operating ranges of the F-DI meet the requirements of EN 61131-2 for Type 1 digital inputs.

---

**Note**

If the length of the F-DI is > 30 m, then shielded cables must be used for the F-DI.

---

### 9.1.2 Safety information

 **WARNING**

**Fire hazard due to overheating because of inadequate ventilation clearances**

Inadequate ventilation clearances can cause overheating with a risk for personnel due to smoke and fire. This can also result in increased failure rates and a shorter service life for Terminal Modules.

- It is absolutely essential that you maintain ventilation clearances according to the table Ventilation clearances above and below the component (Page 310).

### 9.1.3 Interface description

#### 9.1.3.1 Overview

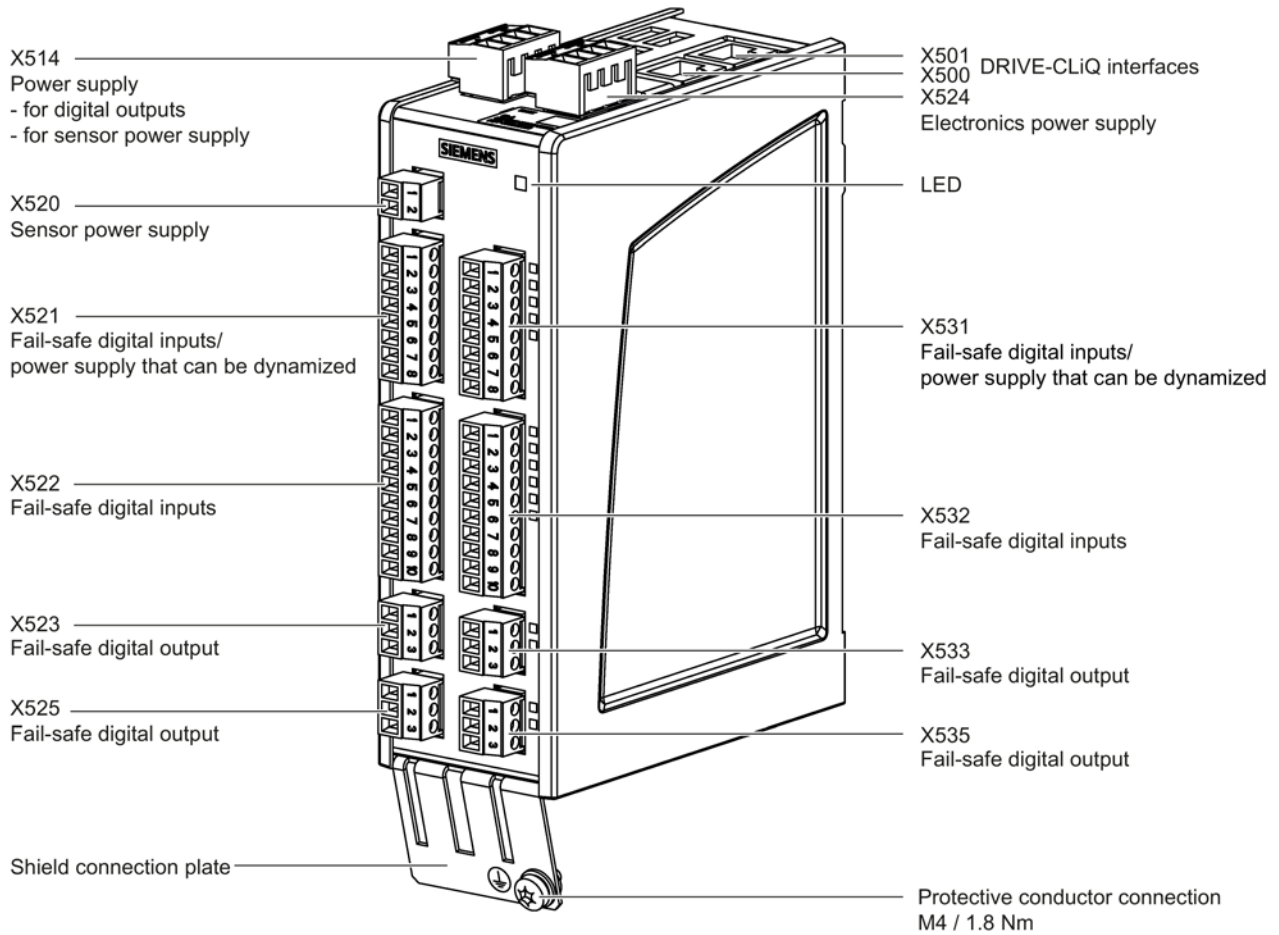
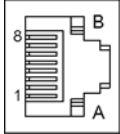

Figure 9-1 TM54 interface overview

9.1.3.2 X500/X501 DRIVE-CLiQ interfaces

Table 9- 2 X500/X501: DRIVE-CLiQ interfaces

	Pin	Signal name	Technical data
	1	TXP	Transmit data +
	2	TXN	Transmit data -
	3	RXP	Receive data +
	4	Reserved, do not use	
	5	Reserved, do not use	
	6	RXN	Receive data -
	7	Reserved, do not use	
	8	Reserved, do not use	
	A	+ (24 V)	Power supply
	B	M (0 V)	Electronics ground

The blanking covers for the DRIVE-CLiQ interfaces are included in the scope of delivery.  
 Blanking covers (50 x) Article number: 6SL3066-4CA00-0AA0

9.1.3.3 X514 power supply for digital outputs and sensors

Table 9- 3 Terminals for the power supply X514

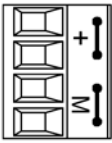
	Terminal	Designation	Technical data
	+	Power supply	Voltage: 24 V DC (20.4 ... 28.8 V) Current consumption: max. 4 A <sup>1)</sup> Max. current via jumper in connector: 20 A (15 A according to UL/CSA) Type: Screw terminal 3 (Page 307) Max. connectable cross-section: 2.5 mm <sup>2</sup> Tightening torque: 0.4 ... 0.5 Nm
	+	Power supply	
	M1	Electronics ground	
	M1	Electronics ground	

<sup>1)</sup> Including the current consumption for the digital outputs and to supply the sensor

The maximum cable length that can be connected is 10 m.

**Note**

The two "+" and "M1" terminals are jumpered in the connector. This ensures that the supply voltage is looped through.

### 9.1.3.4 X520 sensor power supply

Table 9- 4 X520: Sensor power supply

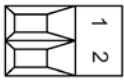
	Terminal	Designation	Technical data
	1	L3	Voltage: +24 V DC Max. total load current: 500 mA
	2	M1	

Without forced dormant error detection

### 9.1.3.5 X521 fail-safe digital inputs + power supply with forced dormant error detection

Table 9- 5 Terminal block X521

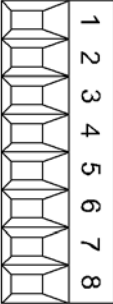
	Terminal	Designation <sup>1)</sup>	Technical data	
	1	L1+	Voltage: +24 V DC Max. total load current: 500 mA	
	2	DI 0	F-DI 0	
	3	DI 1+		
	4	DI 2	F-DI 1	
	5	DI 3+		
	6	DI 1-	F-DI 0	Reference potential for DI 1+
	7	DI 3-	F-DI 1	Reference potential for DI 3+
	8	M1		Reference potential for DI 0, DI 2, L1+
<p>An F-DI comprises a digital input and a 2nd digital input where, in addition, the cathode of the optocoupler is fed-out.            F-DI 0 = terminals 2, 3 and 6            F-DI 1 = terminals 4, 5 and 7</p>				
<p>Type: Screw terminal 1 (Page 307)            Max. connectable cross-section: 1.5 mm<sup>2</sup>            Tightening torque: 0.22 ... 0.25 Nm</p>				

<sup>1)</sup> DI: Digital input, F-DI: Fail-safe digital input

<sup>2)</sup> Pure hardware delay

**Note**

**Operational functionality of DIx+ digital inputs**

For the digital inputs DIx+ to function, the reference potential must be connected to input DIx- in each case.

- Route the ground reference of the digital inputs.
- Connect the DIx input and the M1 terminal via a jumper.

**9.1.3.6 X522 fail-safe digital inputs**

Table 9- 6 Terminal block X522

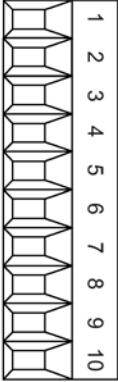
	Terminal	Designation <sup>1)</sup>	Technical data	
	1	DI 4	F-DI 2	
	2	DI 5+		
	3	DI 6	F-DI 3	
	4	DI 7+		
	5	DI 8	F-DI 4	
	6	DI 9+		
	7	DI 5-	F-DI 2	Reference potential for DI 5+
	8	DI 7-	F-DI 3	Reference potential for DI 7+
	9	DI 9-	F-DI 4	Reference potential for DI 9+
	10	M1		Reference potential for DI 4, DI 6 and DI 8
An F-DI comprises a digital input and a second digital input where, in addition, the cathode of the optocoupler is fed-out. F-DI 2 = terminals 1, 2 and 7 F-DI 3 = terminals 3, 4 and 8 F-DI 4 = terminals 5, 6 and 9				
Type: Screw terminal 1 (Page 307) Max. connectable cross-section: 1.5 mm <sup>2</sup> Tightening torque: 0.22 ... 0.25 Nm				

<sup>1)</sup> DI: Digital input, F-DI: Fail-safe digital input

<sup>2)</sup> Pure hardware delay



**Note****Operational functionality of DIx+ digital inputs**

For the digital inputs DIx+ to function, the reference potential must be connected to input DIx- in each case.

- Route the ground reference of the digital inputs.
- Connect the DIx input and the M1 terminal via a jumper.

**9.1.3.7 X523 fail-safe digital output**

Table 9- 7 Terminal block X523

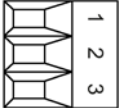
	Terminal	Designation <sup>1)</sup>	Technical data	
	1	DI 20	F-DO 0 Voltage: -3 ... +30 V DC Current consumption, typical: 3.2 mA at 24 V Electrical isolation: Reference potential is terminal M1. The digital input is electrically isolated. Level (incl. ripple) High level: 15 ... 30 V Low level: -3 ... +5 V Input delay: <sup>2)</sup> for "0" → "1": 30 μs (100 Hz) for "1" to "0": 60 μs (100 Hz)	
	2	DO 0+		0.5 A Reference potential is terminal M1 0.5 A Reference potential is terminal L1+, L2+ or L3+ Output delay: <sup>2)</sup> - for "0" → "1": 300 μs for "1" → "0": 350 μs Total current consumption of all DOs: 2 A Max. leakage current: < 0.5 mA Switching frequency: for ohmic load: Max. 100 Hz for inductive load: Max. 0.5 Hz for lamp load: Max. 10 Hz Maximum lamp load: 5 W
	3	DO 0-		
An F-DO comprises 2 digital outputs and 1 digital input for feedback signal F-DO 0 = terminals 1, 2, and 3				
Type: Screw terminal 1 (Page 307) Max. connectable cross-section: 1.5 mm <sup>2</sup> Tightening torque: 0.22 ... 0.25 Nm				

<sup>1)</sup> DI: digital input; DO: digital output F-DO: Fail-safe digital output

<sup>2)</sup> Pure hardware delay

9.1.3.8 X524 Electronics power supply

Table 9- 8 Terminals for the electronics power supply

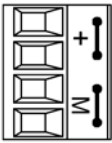
	Terminal	Designation	Technical data
	+	Electronics power supply	Voltage: 24 V DC (20.4 ... 28.8 V) Current consumption: Max. 0.7 A
	+	Electronics power supply	
	M	Electronics ground	Max. current via jumper in connector: 20 A (15 A according to UL/CSA)
	M	Electronics ground	

The maximum cable length that can be connected is 10 m.

**Note**

The two "+" and "M" terminals are jumpered in the connector. This ensures that the supply voltage is looped through.

The current consumption increases by the value for the DRIVE-CLiQ node.

## 9.1.3.9 X525 fail-safe digital output

Table 9- 9 Terminal block X525

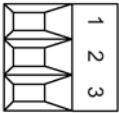
	Terminal	Designation <sup>1)</sup>		Technical data
	1	DI 21	F-DO 1	Voltage: -3 ... +30 V DC Current consumption, typical: 3.2 mA at 24 V Electrical isolation: Reference potential is terminal M1 The digital input is electrically isolated.  Level (incl. ripple) High level: 15 ... 30 V Low level: -3 ... +5 V  Input delay: <sup>2)</sup> for "0" → "1": 30 μs (100 Hz) for "1" to "0": 60 μs (100 Hz)
	2	DO 1+		0.5 A Reference potential is terminal M1
	3	DO 1-		0.5 A Reference potential is terminal L1+, L2+ or L3+  Output delay: <sup>2)</sup> - for "0" → "1": 300 μs for "1" → "0": 350 μs  Total current consumption of all DOs: 2 A Max. leakage current: < 0.5 mA  Switching frequency: for ohmic load: Max. 100 Hz for inductive load: Max. 0.5 Hz for lamp load: Max. 10 Hz Maximum lamp load: 5 W
An F-DO comprises 2 digital outputs and 1 digital input for feedback signal F-DO 1 = terminals 1, 2, and 3				
Type: Screw terminal 1 (Page 307) Max. connectable cross-section: 1.5 mm <sup>2</sup> Tightening torque: 0.22 ... 0.25 Nm				

<sup>1)</sup> DI: digital input; DO: digital output F-DO: Fail-safe digital output

<sup>2)</sup> Pure hardware delay

9.1.3.10 X531 fail-safe digital inputs + power supply with forced dormant error detection

Table 9- 10 Terminal block X531

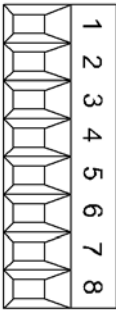
	Terminal	Designation <sup>1)</sup>		Technical data	
	1	L 2+		Voltage: 24 V DC Max. total load current: 500 mA	
	2	DI 10	F-DI 5	Voltage: -3 ... +30 V DC Current consumption, typical: 3.2 mA at 24 V Electrical isolation: Reference potential, refer to terminals 6, 7, 8 All digital inputs are electrically isolated. Level (incl. ripple) High level: 15 ... 30 V Low level: -3 ... +5 V Input delay: <sup>2)</sup> - for "0" → "1": 30 μs (100 Hz) - for "1" to "0": 60 μs (100 Hz)	
	3	DI 11+			
	4	DI 12	F-DI 6		
	5	DI 13+			
	6	DI 11-	F-DI 5		Reference potential to DI 11+
	7	DI 13-	F-DI 6		Reference potential to DI 13+
	8	M1	Reference potential to DI 10, DI 12, L2+		
An F-DI comprises a digital input and a 2nd digital input where, in addition, the cathode of the optocoupler is fed-out. F-DI 5 = terminals 2, 3 and 6 F-DI 6 = terminals 4, 5 and 7					
Type: Screw terminal 1 (Page 307) Max. connectable cross-section: 1.5 mm <sup>2</sup> Tightening torque: 0.22 ... 0.25 Nm					

1) DI: Digital input, F-DI: Fail-safe digital input

2) Pure hardware delay

**Note**

**Operational functionality of DIx+ digital inputs**

For the digital inputs DIx+ to function, the reference potential must be connected to input DIx- in each case.

- Route the ground reference of the digital inputs.
- Connect the DIx input and the M1 terminal via a jumper.

### 9.1.3.11 X532 fail-safe digital inputs

Table 9- 11 Terminal block X532

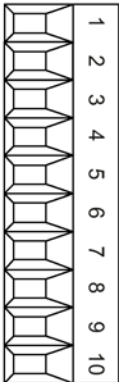
	Terminal	Designation <sup>1)</sup>		Technical data	
	1	DI 14	F-DI 7	Voltage: -3 ... +30 V DC Current consumption, typical: 3.2 mA at 24 V Electrical isolation: Reference potential, refer to terminals 7, 8, 9, 10 All digital inputs are electrically isolated.  Level (incl. ripple) High level: 15 ... 30 V Low level: -3 ... +5 V Input delay: <sup>2)</sup> for "0" → "1": 30 μs (100 Hz) for "1" to "0": 60 μs (100 Hz)	
	2	DI 15+			
	3	DI 16	F-DI 8		
	4	DI 17+			
	5	DI 18	F-DI 9		
	6	DI 19+			
	7	DI 15-	F-DI 7		Reference potential for DI 15+
	8	DI 17-	F-DI 8		Reference potential for DI 17+
	9	DI 19-	F-DI 9		Reference potential for DI 19+
	10	M1			Reference potential for DI 14, DI 16 and DI 18
An F-DI comprises a digital input and a second digital input where, in addition, the cathode of the optocoupler is fed-out. F-DI 7 = terminals 1, 2 and 7 F-DI 8 = terminals 3, 4 and 8 F-DI 9 = terminals 5, 6 and 9					
Type: Screw terminal 1 (Page 307) Max. connectable cross-section: 1.5 mm <sup>2</sup> tightening torque: 0.22 ... 0.25 Nm					

1) DI: Digital input, F-DI: Fail-safe digital input

2) Pure hardware delay

#### Note

##### Operational functionality of DIx+ digital inputs

For the digital inputs DIx+ to function, the reference potential must be connected to input DIx- in each case.

- Route the ground reference of the digital inputs.
- Connect the DIx input and the M1 terminal via a jumper.

9.1.3.12 X533 fail-safe digital output

Table 9- 12 Terminal block X533

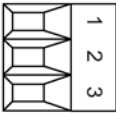
	Terminal	Designation <sup>1)</sup>		Technical data
	1	DI 22	F-DO 2	Voltage: -3 ... +30 V DC Current consumption, typical: 3.2 mA at 24 V Electrical isolation: Reference potential is terminal M1. The digital input is electrically isolated. Level (incl. ripple) High level: 15 ... 30 V Low level: -3 ... +5 V Input delay: <sup>2)</sup> for "0" → "1": 30 µs (100 Hz) for "1" to "0": 60 µs (100 Hz)
	2	DO 2+		0.5 A Reference potential is terminal M1
	3	DO 2-		0.5 A Reference potential is terminal L1+, L2+ or L3+ Output delay: <sup>2)</sup> - for "0" → "1": 300 µs for "1" → "0": 350 µs Total current consumption of all DOs: 2 A Max. leakage current: < 0.5 mA Switching frequency: for ohmic load: Max. 100 Hz for inductive load: Max. 0.5 Hz for lamp load: Max. 10 Hz Maximum lamp load: 5 W
An F-DO comprises two digital outputs and one digital input for feedback F-DO 2 = terminals 1, 2, and 3				
Type: Screw terminal 1 (Page 307) Max. connectable cross-section: 1.5 mm <sup>2</sup> Tightening torque:				

<sup>1)</sup> DI: digital input; DO: digital output F-DO: Fail-safe digital output

<sup>2)</sup> Pure hardware delay

## 9.1.3.13 X535 fail-safe digital output

Table 9- 13 Terminal block X535

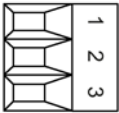
	Terminal	Designation <sup>1)</sup>		Technical data
	1	DI 23	F-DO 3	Voltage: -3 ... +30 V DC Current consumption, typical: 3.2 mA at 24 V Electrical isolation: Reference potential is terminal M1. The digital input is electrically isolated.  Level (incl. ripple) High level: 15 ... 30 V Low level: -3 ... +5 V  Input delay: <sup>2)</sup> for "0" → "1": 30 μs (100 Hz) for "1" to "0": 60 μs (100 Hz)
	2	DO 3+		0.5 A Reference potential is terminal M1
	3	DO 3-		0.5 A Reference potential is terminal L1+, L2+ or L3+  Output delay: <sup>2)</sup> - for "0" → "1": 300 μs for "1" → "0": 350 μs  Total current consumption of all DOs: 2 A Max. leakage current: < 0.5 mA  Switching frequency: for ohmic load: Max. 100 Hz for inductive load: Max. 0.5 Hz for lamp load: Max. 10 Hz Maximum lamp load: 5 W
An F-DO comprises 2 digital outputs and 1 digital input for feedback signal F-DO 3 = terminals 1, 2, and 3				
Type: Screw terminal 1 (Page 307) Max. connectable cross-section: 1.5 mm <sup>2</sup> Tightening torque: 0.22 ... 0.25 Nm				

<sup>1)</sup> DI: digital input; DO: digital output F-DO: Fail-safe digital output

<sup>2)</sup> Pure hardware delay

### 9.1.4 Connection example

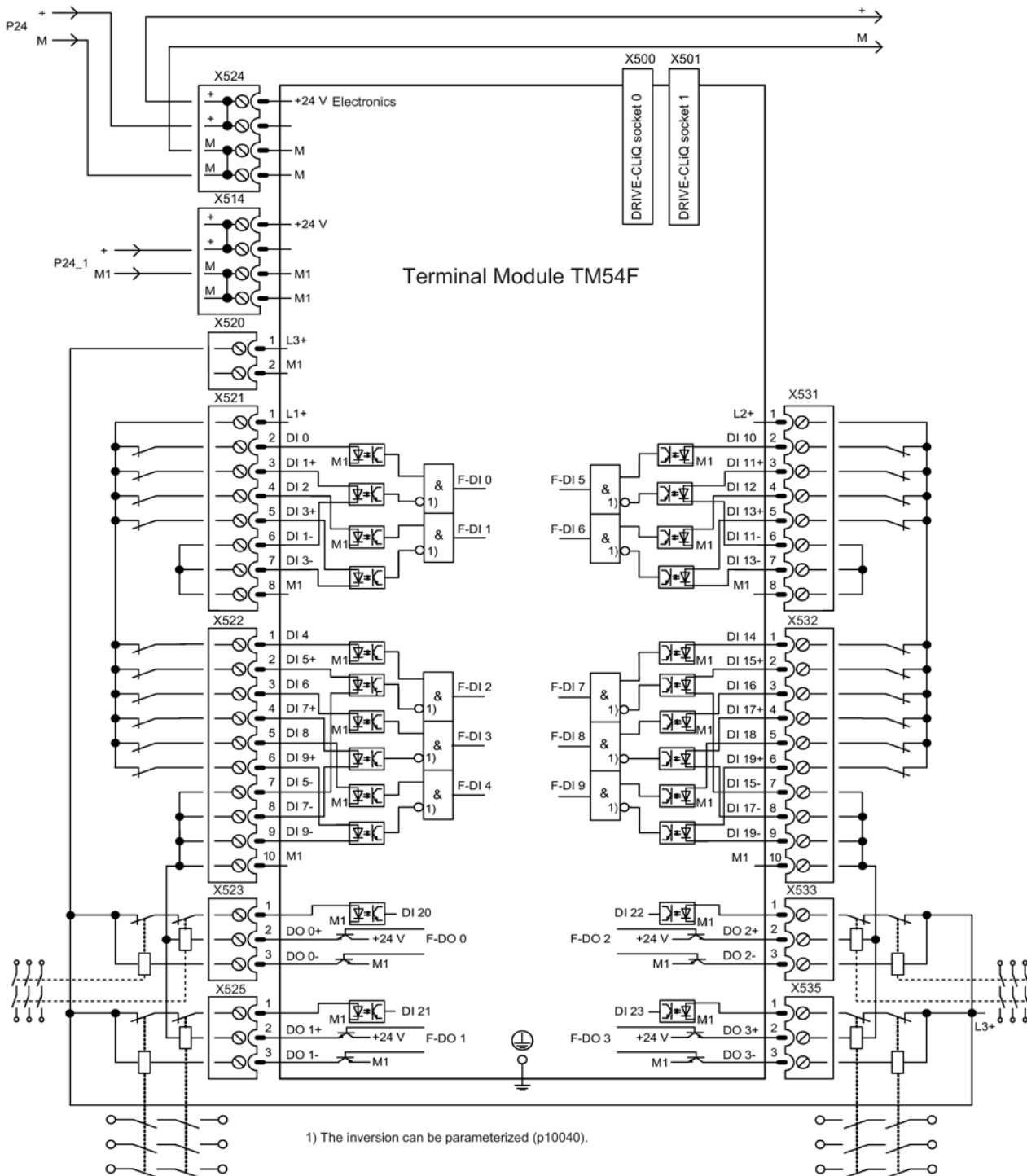

Figure 9-2 Connection example off TM54F



## 9.1.5 Meaning of LEDs

Table 9- 14 Meaning of the LEDs on the Terminal Module TM54F

LED	Color	Status	Description, cause	Remedy	
READY	-	Off	The electronics power supply is missing or outside the permissible tolerance range.	-	
	Green	Continuous light	The component is ready for operation, cyclic DRIVE-CLiQ communication is taking place.	-	
	Orange	Continuous light	DRIVE-CLiQ communication is being established.	-	
	Red	Continuous light	This component has at least one fault. <b>Remark:</b> The LED is activated irrespective of whether the corresponding messages have been reconfigured.	Remedy and acknowledge fault or safely acknowledge the fault	
	Green/red	Flashing light	0.5 Hz	Firmware is being downloaded.	-
			2 Hz	Firmware download is complete. Wait for POWER ON.	Carry out a POWER ON
	Green / orange or Red / orange	Flashing light 1 Hz	Component recognition via LED is activated (p0154 = 1). <b>Remark:</b> Both options depend on the LED status when component recognition is activated. Green / orange: Component is operating without any faults Red/orange: Component signals a fault	-	
L1+, L2+	-	Off	The controllable sensor power supply is functioning fault-free.	-	
	Red	Continuous light	There is a fault in the controllable sensor power supply.	-	
L3+	-	Off	The sensor power supply is operating fault-free.		
	Red	Continuous light	The sensor power supply has a fault.		

LED	Color		Status	Description, cause	Remedy
<b>Fail-safe inputs / double inputs</b>					
F_DI z (input x, (x+1)+, (x+1)-)	<b>LED</b>	<b>LED</b>			–
	x	x+1		<b>NC contact/NC contact<sup>1)</sup>: (z = 0 ... 9, x = 0, 2, ... 18)</b>	
	–	Red	Continuous light	Different signal states at input x and x+1	
	–	–	Off	No signal at input x and no signal at input x+1	
	<b>NC contact/NO contact<sup>1)</sup>: (z = 0 ... 9, x = 0, 2, ... 18)</b>				
	–	Red	Continuous light	Same signal states at input x and x+1	
	–	–	Off	No signal at input x and no signal at input x+1	
	<b>LED</b>	<b>LED</b>			
	x	x+1		<b>NC contact/NC contact<sup>1)</sup>: (z = 0 ... 9, x = 0, 2, ... 18)</b>	
	Green	Green	Continuous light	One signal at input x and one signal at input x+1	
<b>NC contact/NO contact<sup>1)</sup>: (z = 0 ... 9, x = 0, 2, ... 18)</b>					
Green	Green	Continuous light	One signal at input x and no signal at input x+1	–	
<b>Single digital inputs, not fail-safe</b>					
DI x	–		Off	No signal at digital input x (x = 20 ... 23)	–
	Green		Continuous light	Signal at digital input x	–
<b>Fail-safe digital outputs with associated readback channel</b>					
F_DO y (0+...3+, 0-...3-)	Green		Continuous light	Output y (y = 0 ... 3) has an active signal	–
Readback input DI 2y for output F_DO y (y = 0 ... 3) for test stop. The status of the LEDs also depends on the type of external circuit.					
DI 2y	–		Off	One of the two output lines y+ or y- or both lines of output y carry a signal	–
	Green		Continuous light	Both output lines y+ and y- carry no signal	–

<sup>1)</sup> Inputs x+1 (DI 1+, 3+, .. 19+) can be individually set using a parameter  
Additional information can be taken from the following reference:  
Reference: /LH1/ SINAMICS S120/S150 List Manual

### Cause and rectification of faults

The following reference contains information about the cause of faults and how they can be rectified:

SINAMICS S120 Commissioning Manual (IH1)

SINAMICS S120/S150, List Manual (LH1)

### 9.1.6 Dimension drawing

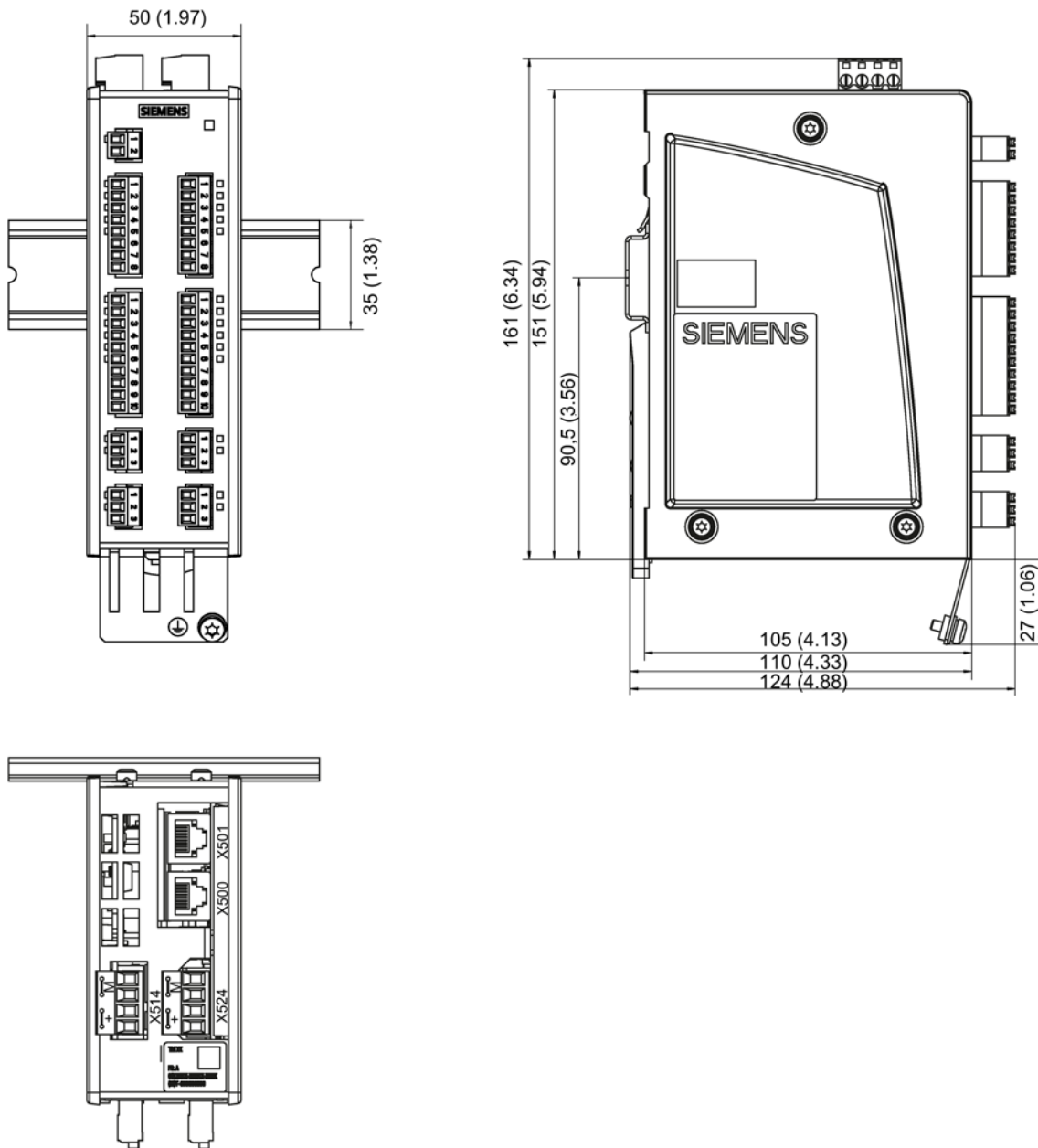

Figure 9-3 Dimension drawing of Terminal Module TM54F, all data in mm and (inches)

## 9.1.7 Installation

### Installation

1. Tilt the component backwards slightly and attach it to the DIN rail using the hooks.
2. Swivel the component onto the DIN rail until you hear the mounting slide at the rear latch into position.
3. Slide the components along the mounting rail to either the left or right up to their final position.

### Removal

1. First shift the mounting slide downwards at the lug to release the interlocking with the mounting rail.
2. Swivel the component to the front and withdraw it upwards from the DIN rail.

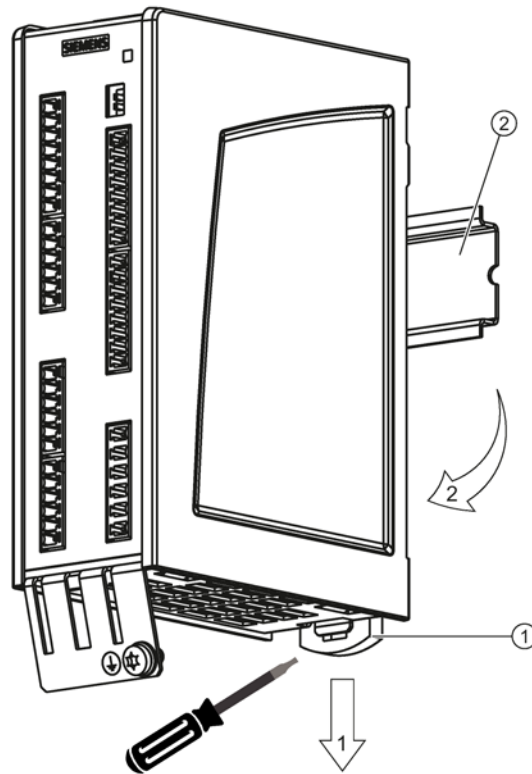

- ① Mounting slide
- ② Mounting rail

Figure 9-4 Removing from a DIN mounting rail

### 9.1.8 Protective conductor connection and shield support

It is always advisable to shield the digital input and output wiring.

The following diagram shows a typical Weidmüller shield connection clamp for the shield support.



- ① Shield connection terminal, Weidmüller company, type: KLBUE CO1, Article number: 1753311001
- ② Protective conductor connection M4 / 1.8 Nm

Figure 9-5 Protective conductor connection and shield support

#### NOTICE

##### Damage or faulty operation due to incorrect shielding or inadmissible cable lengths

If the correct shielding procedures or the permissible cable lengths are not observed, it can cause damage or the machine may malfunction.

- Only use shielded cables.
- Do not exceed the cable lengths stated in the technical data.

## 9.1.9 Technical data

Table 9- 15 Technical data

6SL3055-0AA00-3BA.	Unit	Value
<b>Current requirement X524</b> (at 24 V DC) without DRIVE-CLiQ supply	mA	160
<b>Current requirement X514</b> (at 24 V DC) without digital outputs and sensor power supply	mA	38
<b>Sensor power supply with and without forced dormant error detection (L1+, L2+, L3+)</b>		
Voltage	V	24
Max. load current per output	A	0.5
<b>Max. cable length for the 24 V supply:</b> For longer cable lengths, surge protection device "Weidmüller type No. MCZ OVP TAZ DIODE 24 VDC" should be used.	m	30
<b>Power loss</b>	W	4.5 at 24 V
<b>PE/ground connection</b>		At the housing with M4 screw
<b>Weight</b>	kg	Approx. 0.9

## 9.2 DRIVE-CLiQ Hub Module DMC20

### 9.2.1 Description

The DRIVE-CLiQ Hub Module DMC20 is a DRIVE-CLiQ component and can be snapped onto a standard mounting rail (EN 60715). It is only used to connect direct measuring systems for the feed axes and expansion axes of the S120 Combi.

---

#### Note

The DMC20 should also be used if only one feed axis is coupled with a direct measuring system.

---

A fixed topology applies when assigning the particular feed axis to a DRIVE-CLiQ interface (see Section Topology rules for DRIVE-CLiQ (Page 131)) and this must be observed.

## 9.2.2 Safety information

 <b>WARNING</b>
<b>Danger to life if the fundamental safety instructions and remaining risks are not carefully observed</b>
If the fundamental safety instructions and remaining risks in Chapter 1 (Page 21) are not observed, accidents involving severe injuries or death may occur.
<ul style="list-style-type: none"><li>• Adhere to the fundamental safety instructions.</li><li>• When assessing the risk, take into account residual risks.</li></ul>

 <b>WARNING</b>
<b>Fire hazard due to overheating because of inadequate ventilation clearances</b>
Inadequate ventilation clearances can cause overheating with a risk for personnel due to smoke and fire. This can also result in increased failure rates and a shorter service life for Hub Modules.
<ul style="list-style-type: none"><li>• It is absolutely essential that you maintain ventilation clearances according to the table Ventilation clearances above and below the component (Page 310).</li></ul>

### Note

All components operated on the DRIVE-CLiQ must be integrated into the equipotential bonding concept.  
They should preferably be connected by installing them on bare metal machine parts and devices, which are all bonded to one another in an equipotential manner.  
Alternatively, equipotential bonding can be achieved by means of a conductor (min. 6 mm<sup>2</sup>), which should be routed parallel to the DRIVE-CLiQ where possible. This involves all distributed DRIVE-CLiQ participants.

## 9.2.3 Interface description

### 9.2.3.1 Overview

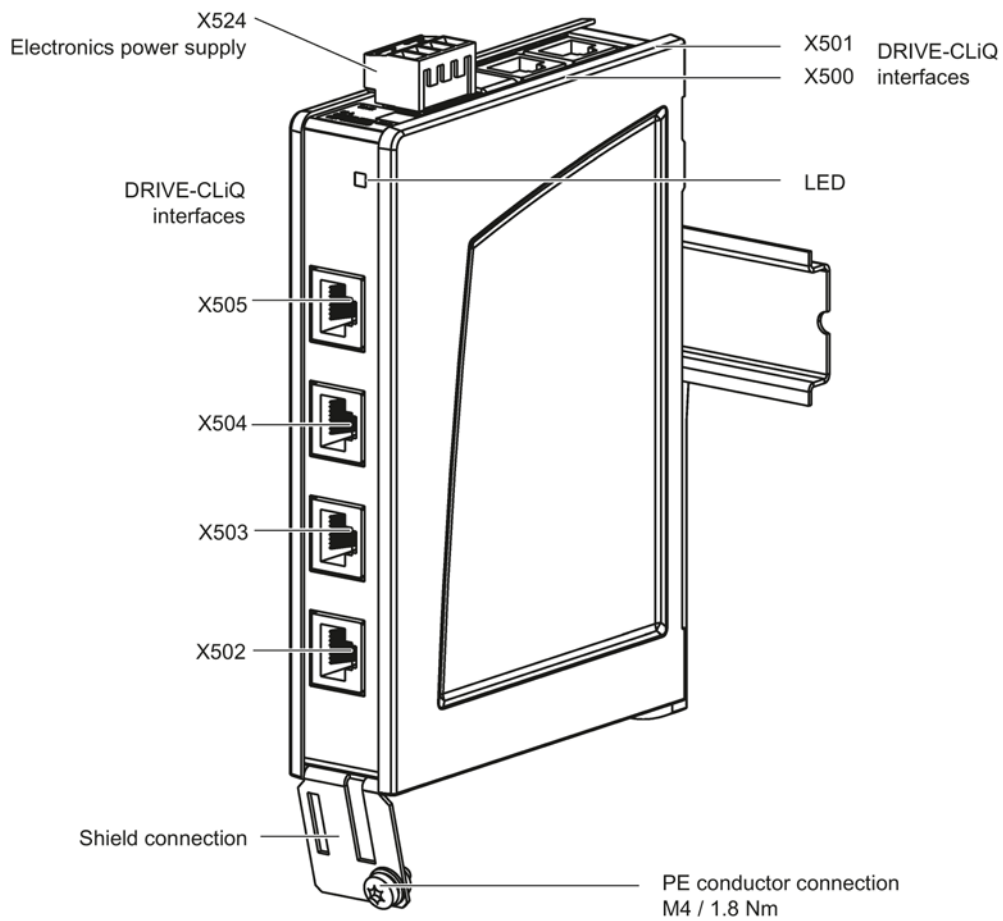
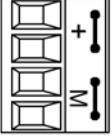

Figure 9-6 Interface overview of the DMC20



### 9.2.3.2 X524 Electronics power supply

Table 9- 16 Terminals for the electronics power supply

	Terminal	Designation	Technical data
	+	Electronics power supply	Voltage: 24 V DC (20.4 ... 28.8 V) Current consumption: max. 0.5 A Max. current via jumper in connector: 20 A (15 A according to UL/CSA) Type: Screw terminal 3 (Page 307) Max. connectable cross-section: 2.5 mm <sup>2</sup> Tightening torque: 0.4 ... 0.5 Nm
	+	Electronics power supply	
	M	Electronics ground	
	M	Electronics ground	

The maximum cable length that can be connected is 10 m.

#### Note

The two "+" and "M" terminals are jumpered in the connector. This ensures that the supply voltage is looped through.

The current consumption increases by the value for the DRIVE-CLiQ participants.

### 9.2.3.3 X500-X505 DRIVE-CLiQ interfaces

Table 9- 17 X500-X505: DRIVE-CLiQ interfaces

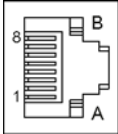
	Pin	Signal name	Technical data
	1	TXP	Transmit data +
	2	TXN	Transmit data -
	3	RXP	Receive data +
	4	Reserved, do not use	
	5	Reserved, do not use	
	6	RXN	Receive data -
	7	Reserved, do not use	
	8	Reserved, do not use	
	A	+ (24 V)	Power supply
	B	M (0 V)	Electronics ground
Connector type	DRIVE-CLiQ socket		

The blanking covers for the DRIVE-CLiQ interfaces are included in the scope of delivery.

Blanking covers (50 x) Article No.: 6SL3066-4CA00-0AA0

**Note**

Only MOTION-CONNECT DRIVE-CLiQ cables may be used to establish connections. The maximum length of MOTION-CONNECT 500 is 100 m and for MOTION-CONNECT 800PLUS cables, 75 m.

**9.2.3.4 Meaning of the LED on the DMC20**

Table 9- 18 Meaning of the LED on the DMC20

LED	Color	Status	Description
READY	-	Off	The electronics power supply is missing or outside the permissible tolerance range.
	Green	Continuous light	The component is ready for operation and cyclic DRIVE-CLiQ communication is taking place.
	Orange	Continuous light	DRIVE-CLiQ communication is being established.
	Red	Continuous light	This component has at least one fault. <b>Note:</b> The LED is activated irrespective of whether the corresponding messages have been reconfigured.
	Green / Red	0.5 Hz flashing light	Firmware is being downloaded.
		2 Hz flashing light	Firmware download is complete. Wait for POWER ON
	Green / Orange or Red / Orange	Flashing light	Component recognition via LED is activated. This function is parameterizable (see SINAMICS S120/S150 List Manual). <b>Note:</b> Both options depend on the LED status when component recognition is activated.

**Cause and rectification of faults**

The following reference contains information about the cause of faults and how they can be rectified:

SINAMICS S120 Commissioning Manual (IH1)

SINAMICS S120/S150, List Manual (LH1)

### 9.2.4 Dimension drawing

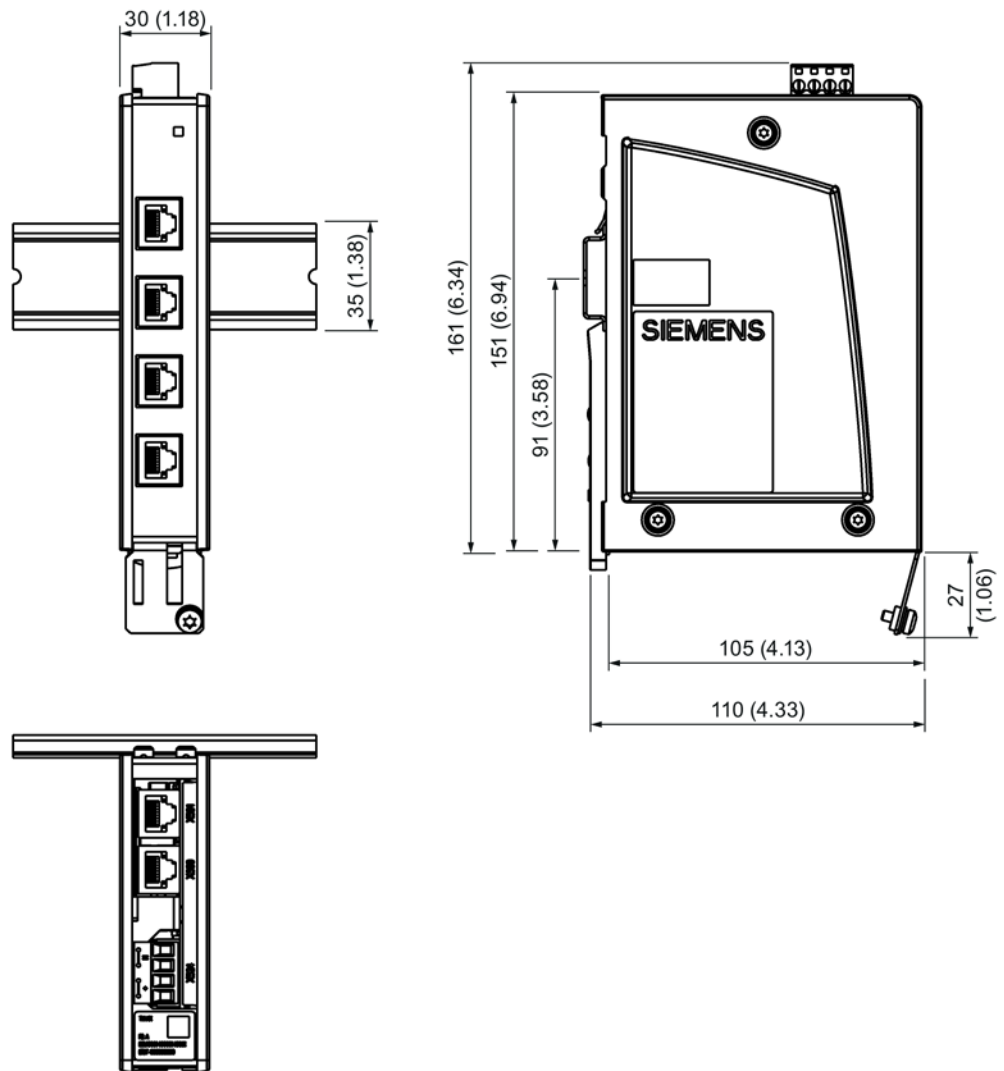

Figure 9-7 Dimension drawing of the DRIVE-CLiQ Hub Module DMC20, all data in mm and (inches)

## 9.2.5 Installation

### Installation

1. Tilt the component backwards slightly and attach it to the DIN rail using the hooks.
2. Swivel the component onto the DIN rail until you hear the mounting slide at the rear latch into position.
3. Slide the components along the mounting rail to either the left or right up to their final position.

### Removal

1. First shift the mounting slide downwards at the lug to release the interlocking with the mounting rail.
2. Swivel the component to the front and withdraw it upwards from the DIN rail.

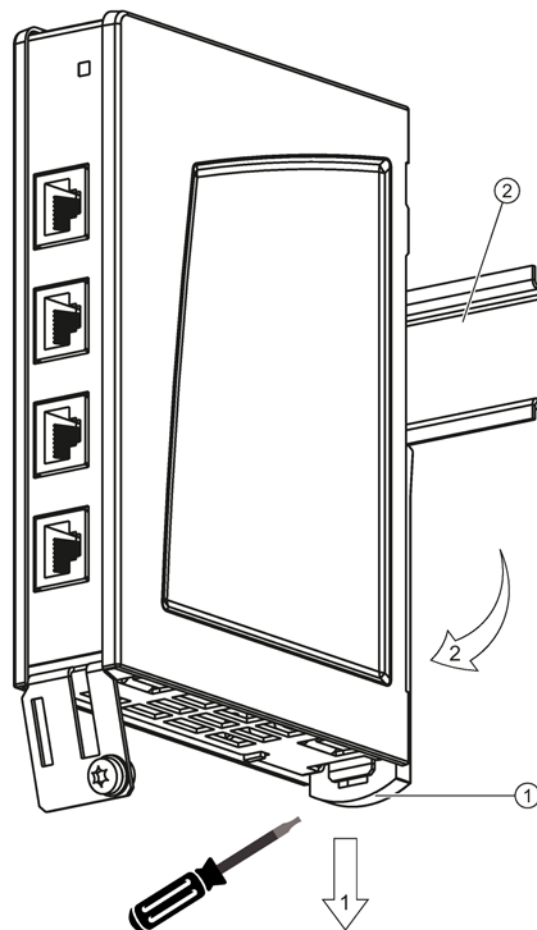

- ① Mounting slide  
② Mounting rail

Figure 9-8 Removing from a DIN mounting rail

## 9.2.6 Technical data

Table 9- 19 Technical data of the DMC20

6SL3055-0AA00-6AA1	Unit	Value
<b>Electronics power supply</b>		
Voltage	V <sub>DC</sub>	24 V DC (20.4 ... 28.8)
Current (without DRIVE-CLiQ node)	A <sub>DC</sub>	0.15
Maximum cable length	m	30
PE/ground connection	At the housing with M4 screw	
Weight	kg	0.36

## 9.3 DRIVE-CLiQ Hub Module External DME20

### 9.3.1 Description

The DRIVE-CLiQ Hub Module External DME20, just like the DRIVE-CLiQ Hub Module DMC20, is only used to connect direct measuring systems for the feed axes and expansion axes of the S120 Combi.

The component has degree of protection IP67.

---

#### Note

The DME20 should also be used if only one feed axis is coupled with a direct measuring system.

---

A fixed topology applies when assigning the particular feed axis to a DRIVE-CLiQ interface (see Section Topology rules for DRIVE-CLiQ (Page 131)) and this must be observed.

## 9.3.2 Safety information

 **WARNING**

**Danger to life if the fundamental safety instructions and remaining risks are not carefully observed**

If the fundamental safety instructions and remaining risks in Chapter 1 (Page 21) are not observed, accidents involving severe injuries or death may occur.

- Adhere to the fundamental safety instructions.
- When assessing the risk, take into account residual risks.

**NOTICE**

**Damage due to leaking plug connections**

If IP67 protection is not ensured, water or dirt can enter and lead to material damage.

- All plug connectors must be correctly screwed into place and appropriately locked.

**Note**

**Malfunctions due to polluted DRIVE-CLiQ interfaces**

Malfunctions can occur in the system through the use of polluted DRIVE-CLiQ interfaces.

- Cover unused DRIVE-CLiQ interfaces with the supplied blanking covers.

**Note**

All components operated on the DRIVE-CLiQ must be integrated into the equipotential bonding concept.

They should preferably be connected by installing them on bare metal machine parts and devices, which are all bonded to one another in an equipotential manner.

Alternatively, equipotential bonding can be achieved by means of a conductor (min. 6 mm<sup>2</sup>), which should be routed parallel to the DRIVE-CLiQ where possible. This applies to all distributed DRIVE-CLiQ participants.

For the DME20 this also applies to the 24 V power supply.

### 9.3.3 Interface description

#### 9.3.3.1 Overview

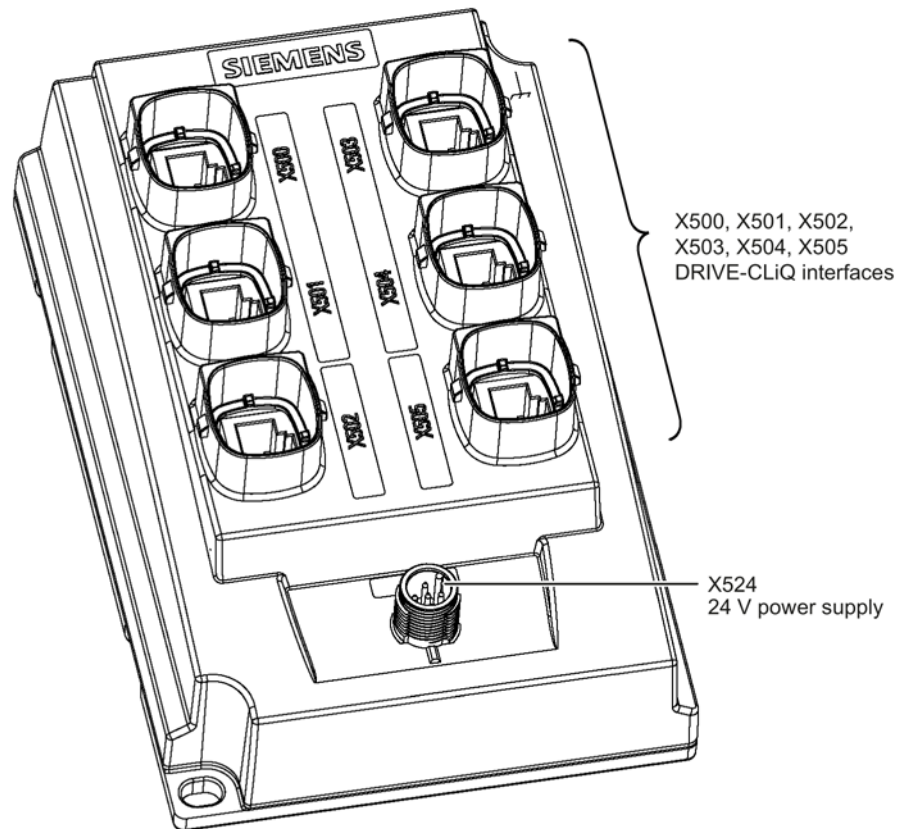
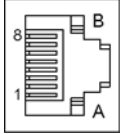

Figure 9-9 Interface overview of the DME20

9.3.3.2 X500-X505 DRIVE-CLiQ interfaces

Table 9- 20 X500-X505: DRIVE-CLiQ interfaces

	Pin	Signal name	Technical data
	1	TXP	Transmit data +
	2	TXN	Transmit data -
	3	RXP	Receive data +
	4	Reserved, do not use	
	5	Reserved, do not use	
	6	RXN	Receive data -
	7	Reserved, do not use	
	8	Reserved, do not use	
	A	+ (24 V)	Power supply
	B	M (0 V)	Electronics ground
Connector type	DRIVE-CLiQ socket		

The blanking covers for the DRIVE-CLiQ interfaces are included in the scope of delivery.

Blanking covers (6 units), article number: 6SL3066-4CA01-0AA0

**Note**

Only MOTION-CONNECT DRIVE-CLiQ cables may be used to establish connections. The maximum length of MOTION-CONNECT 500 is 100 m and for MOTION-CONNECT 800PLUS cables, 75 m.

9.3.3.3 X524 Electronics power supply

Table 9- 21 X524: Electronics power supply

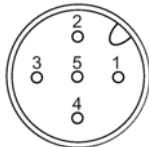
	Pin	Designation	Technical data
	1	Electronics power supply	The supply voltage of 20.4 V ... 28.8 V refers to the (terminal) voltage at the DME20. This must be taken into account when selecting the cable cross-section and supply cable lengths. Pins 1 and 2: jumpered internally Pins 3 and 4: jumpered internally
	2	Electronics power supply	
	3	Electronics ground	
	4	Electronics ground	
	5	Not connected	
			Type: 5-pin socket max. connectable cross-section: 4 x 0.75 mm <sup>2</sup>



**Note**

The maximum cable length for the 24 V supply of the DME20 is 100 m.

In case no UL-compliant design is required, is the use of the following cables and connectors from Siemens is recommended:

**Pre-assembled cables**

Connecting cable for power supply with M12 plug and M12 socket,  
A-coded, 4-pin,  
Article number: 6XV1801-5D..

**Cables to be assembled by the user**

Cable	Connector
24 V DC cable, 2-wire, 2 x 0.75 mm <sup>2</sup> , Article number: 6XV1812-8A	M12 plug connector, 4-pin, A-coded, Article number: 6GK1907-0DC10-6AA3

Table 9- 22 Cable length P24 supply cable

Connected loads <sup>1)</sup> m	1	2	3	4	5
<b>Cross-section</b>					
0.34 mm <sup>2</sup>	75 m	45 m	30 m	25 m	20 m
2 x 0.34 mm <sup>2</sup>	100 m	90 m	65 m	50 m	40 m
0.75 mm <sup>2</sup>	100 m	100 m	75 m	60 m	50 m
2 x 0.75 mm <sup>2</sup>	100 m	100 m	100 m	100 m	100 m
T <sub>a</sub> = 55 °C 100 m DRIVE-CLiQ					

<sup>1)</sup> Connected motors with DRIVE-CLiQ encoder, DRIVE CLiQ mounted encoder SME

### 9.3.4 Dimension drawing

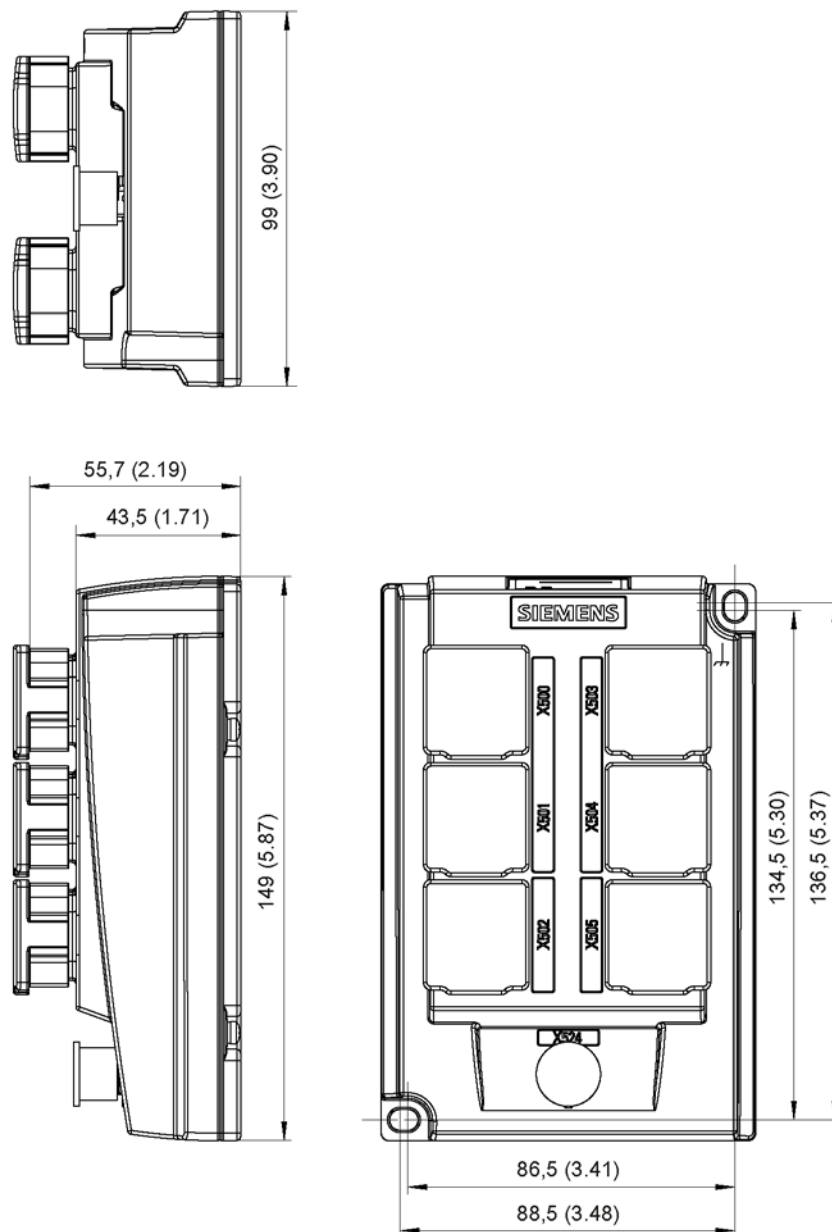
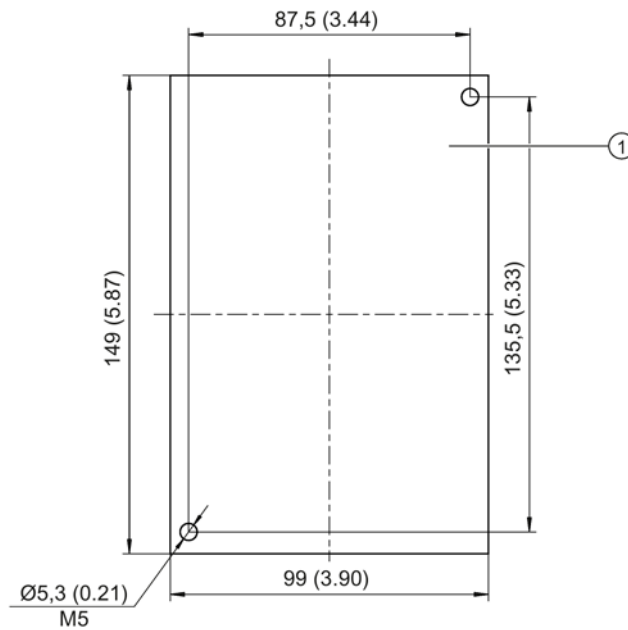

Figure 9-10 Dimension drawing of the DRIVE-CLiQ Hub Module External DME20, all data in mm and (inches)

### 9.3.5 Installation



① Contact surface

Figure 9-11 Mounting dimensions DME20

### Installation

1. Place the drilling pattern on the mounting surface. Make sure that the contact surface is bare, unpainted metal.
2. Drill two holes with  $\varnothing 5.3$  or M5 threaded holes according to the drilling pattern.
3. Mount the DME20 DRIVE-CLiQ Hub Module External on the contact surface. The tightening torque is 6.0 Nm.

### 9.3.6 Technical data

Table 9- 23 Technical data of the DME20

6SL3055-0AA00-6AB.	Unit	Value
Electronics power supply		
Voltage	V <sub>DC</sub>	24 (20.4 ... 28.8)
Current (without DRIVE-CLiQ node)	A <sub>DC</sub>	0.15
PE/ground connection	Screwed to the housing M5	
Weight	kg	0.8

### 9.3.7 Specifications for use with UL approval

**Pre-assembled cables**

Sensor/actuator cable, 5-pin, variable cable,  
 free cable end at straight socket M12-SPEEDCON,  
 cable length: 2, 5, 10, 15 m  
 SAC-5P-...-186/FS SCO  
 Up to 100 m on request

Phoenix Contact

**Cables to be assembled by the user**

Cable	Connector
Cable coil, black PUR/PVC, 5-pin Conductor colors: brown/white/blue/black/gray Cable length: 100 m SAC-5P-100.0-186/0.75 Article number: 1535590	Sensor/actuator connector, socket, straight, 5-pin, M12, A-coded Screw connection, metal knurl, cable gland Pg9 SACC-M12FS-5CON-PG9-M Article number: 1681486
Phoenix Contact	

**Power supply**

The DME20 must use one of the following 24 V power supplies with voltage limiting:

- SITOP 6EP1x.. or 6ES7307..
- SINAMICS Control Supply Module 6SL3100-1DE22-0A...

**Cable pin assignment**

Table 9- 24 Connection to X524 electronics power supply

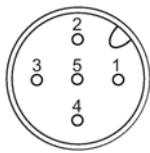
	Pin	Designation	Technical data
	1 (brown) <sup>1)</sup>	Electronics power supply	The supply voltage of 20.4 V ... 28.8 V refers to the (terminal) voltage at the DME20. This must be taken into account when selecting the cable cross-section and supply cable lengths. Pins 1 and 2: jumpered internally Pins 3 and 4: jumpered internally
	2 (white) <sup>1)</sup>	Electronics power supply	
	3 (black) <sup>1)</sup>	Electronics ground	
	4 (blue) <sup>1)</sup>	Electronics ground	
	5 (gray) <sup>1)</sup>	Not connected internally	

<sup>1)</sup> The colors refer to the cable specified above

## Encoder system connection

### 10.1 Sensor Module Cabinet-Mounted SMC20

#### 10.1.1 Description

The Sensor Module Cabinet-Mounted SMC20 evaluates encoder signals and transmits the speed, actual position value, rotor position and, if necessary, the motor temperature and reference point via DRIVE-CLiQ to the S120 Combi.

The SMC20 is used to evaluate encoder signals from incremental encoders with SIN/COS (1 Vpp) or absolute encoders with EnDat 2.1 or SSI.

#### 10.1.2 Product-specific safety instructions

##### WARNING

**Danger to life if the fundamental safety instructions and remaining risks are not carefully observed**

If the fundamental safety instructions and remaining risks in Chapter 1 (Page 21) are not observed, accidents involving severe injuries or death may occur.

- Adhere to the fundamental safety instructions.
- When assessing the risk, take into account residual risks.

##### WARNING

**Fire hazard due to overheating because of inadequate ventilation clearances**

Inadequate ventilation clearances can cause overheating with a risk for personnel due to smoke and fire. This can also result in increased failure rates and a shorter service life for Sensor Modules.

- Maintaining 50 mm ventilation clearances above and below the component is essential.

##### NOTICE

**Damage when connecting an impermissible number of encoder systems**

If more than the maximum permissible number of encoder systems are connected to a Sensor Module, this will cause damage.

- At a Sensor Module only connect the maximum permissible number of encoder systems.

---

**Note**

**Diminished level of interference immunity due to equalizing currents via the electronics ground**

Make sure there is no electrical connection between the encoder system housing and the signal lines and the sensor system electronics.

If this is not carefully observed, under certain circumstances the system will not be able to reach the required interference immunity level (there is then a danger of equalization currents flowing through the electronics ground).

---

### 10.1.3 Interface description

#### 10.1.3.1 Overview

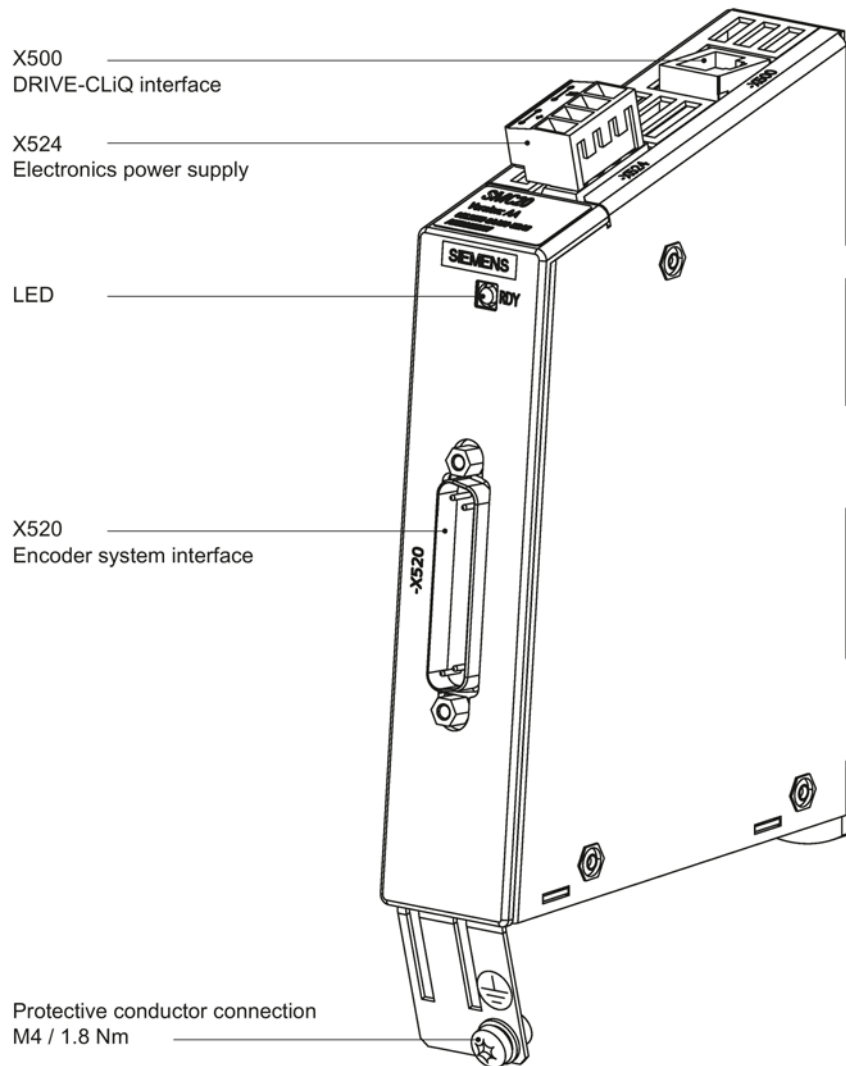
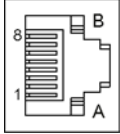

Figure 10-1 Interface description of the SMC20

10.1.3.2 X500 DRIVE-CLiQ interface

Table 10- 1 X500: DRIVE-CLiQ interface

	Pin	Signal name	Technical data
	1	TXP	Transmit data +
	2	TXN	Transmit data -
	3	RXP	Receive data +
	4	Reserved, do not use	
	5	Reserved, do not use	
	6	RXN	Receive data -
	7	Reserved, do not use	
	8	Reserved, do not use	
	A	Reserved, do not use	
	B	M (0 V)	Electronics ground
Connector type	DRIVE-CLiQ socket		

The blanking cover for the DRIVE-CLiQ port is included in the scope of delivery.

Blanking covers (50 x) Article No.: 6SL3066-4CA00-0AA0



### 10.1.3.3 X520 encoder system interface

Table 10- 2 X520: Encoder system interface

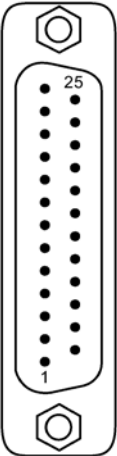
	Pin	Signal name	Technical data
	1	P encoder	Encoder power supply
	2	M encoder	Ground for encoder power supply
	3	A	Incremental signal A
	4	A*	Inverse incremental signal A
	5	Ground	Ground (for internal shield)
	6	B	Incremental signal B
	7	B*	Inverse incremental signal B
	8	Ground	Ground (for internal shield)
	9	Reserved, do not use	
	10	Clock	Clock, EnDat interface, SSI clock
	11	Reserved, do not use	
	12	Clock*	Inverted clock, EnDat interface, inverted SSI clock
	13	+Temp <sup>1)</sup>	Temperature sensor KTY84-1C130 / PT1000 / PTC
	14	P sense	Sense input of encoder power supply
	15	Data	Data, EnDat interface, SSI data
	16	M sense	Ground sense input encoder power supply
	17	R	Reference signal R
	18	R*	Inverse reference signal R
	19	C	Absolute track signal C
	20	C*	Inverse absolute track signal C
	21	D	Absolute track signal D
	22	D*	Inverse absolute track signal D
	23	Data*	Inverse data, EnDat interface, Inverse SSI data
	24	Ground	Ground (for internal shield)
	25	-Temp <sup>1)</sup>	Temperature sensor KTY84-1C130 / PT1000 / PTC
Connector type:	25-pin SUB D connector		
Measuring current via temperature sensor connection: 2 mA			

1) Accuracy of the temperature measurement:

- KTY:  $\pm 7$  °C (including evaluation)
- PT1000:  $\pm 5$  °C (PT1000 tolerance class B according to DIN EN 60751 including evaluation)
- PTC:  $\pm 5$  °C (including evaluation)

**NOTICE**

**Damage to motor due to incorrectly connected KTY temperature sensor**

If a KTY temperature sensor is connected with incorrect polarity, it is not possible to detect when the motor overheats. Overheating can cause damage to the motor.

- Connect a KTY temperature sensor with the correct polarity.

Data regarding the parameterization of the KTY temperature sensor can be taken from the following reference:

Reference: /FH1/ SINAMICS S120 Function Manual, Chapter "Monitoring and protective functions/thermal motor protection"



**! WARNING**

**Danger to life due to electric shock in the event of voltage flashovers at the temperature sensor**

Voltage flashovers in the signal electronics can occur in motors without safe electrical separation of the temperature sensors.

- Use temperature sensors that comply with the specifications relating to protective separation.
- If safe electrical separation cannot be guaranteed (for linear motors or third-party motors, for example), use a Sensor Module External (SME120 or SME125) or Terminal Module TM120.

**10.1.3.4 X524 Electronics power supply**

Table 10- 3 X524 terminal strip

	Terminal	Function	Technical data
	+	Electronics power supply	Voltage: 24 V (20.4 ... 28.8 V) Current consumption: max. 0.35 A Maximum current via jumper in connector: 20 A (15 A according to UL/CSA) Type: Screw terminal 3 (Page 307) Max. connectable cross-section: 2.5 mm <sup>2</sup> Tightening torque: 0.4 ... 0.5 Nm
	+	Electronics power supply	
	M	Electronics ground	
	M	Electronics ground	

The maximum cable length that can be connected is 10 m.

**Note**

The two "+" and "M" terminals are jumpered in the connector. This ensures that the supply voltage is looped through.

### 10.1.3.5 Meaning of the LED on the Sensor Module Cabinet-Mounted SMC20

Table 10- 4 Meaning of the LEDs on the Sensor Module Cabinet-Mounted SMC20

LED	Color	Status	Description, cause	Remedy	
RDY READY	-	Off	The electronics power supply is missing or outside the permissible tolerance range.	-	
	Green	Continuous light	The component is ready for operation. Cyclic DRIVE-CLiQ communication is taking place.	-	
	Orange	Continuous light	DRIVE-CLiQ communication is being established.	-	
	Red	Continuous light	This component has at least one fault. <b>Note:</b> The LED is activated irrespective of whether the corresponding messages have been reconfigured.	Remove and acknowledge the fault.	
	Green/red	Flashing light 0.5 Hz	Firmware is being downloaded.		-
			Firmware download is complete. The system waits for POWER ON.		Carry out a POWER ON.
	Green / orange or Red / orange	Flashing light	Component recognition via LED is activated <sup>1)</sup> . <b>Note:</b> Both options depend on the LED status when component recognition is activated.		-

<sup>1)</sup> The parameters for activating component recognition using LEDs can be taken from the following reference:  
Reference: /LH1/ SINAMICS S120/S150 List Manual

#### Cause and rectification of faults

The following reference contains information about the cause of faults and how they can be rectified:

SINAMICS S120 Commissioning Manual (IH1)

SINAMICS S120/S150, List Manual (LH1)

### 10.1.4 Dimension drawing

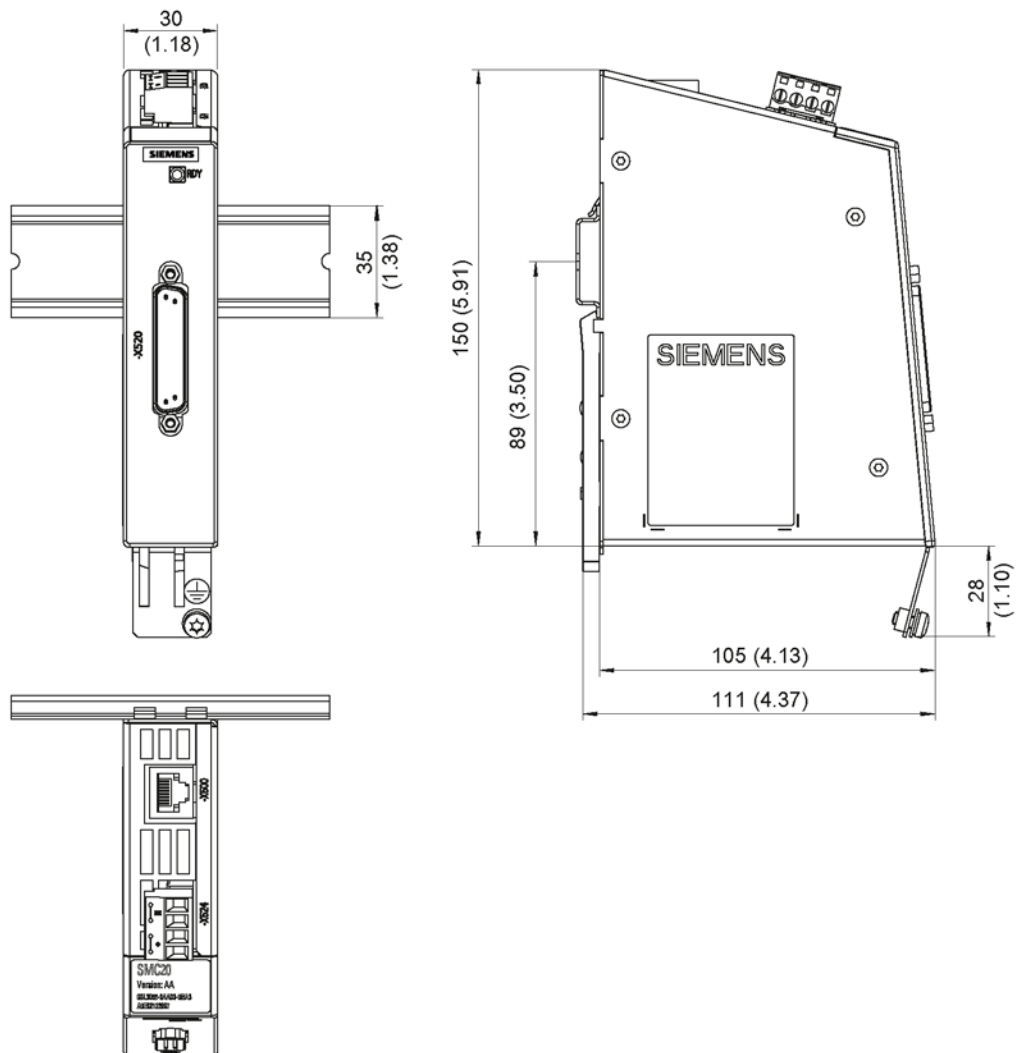

Figure 10-2 Dimension drawing of the Sensor Module Cabinet SMC20, all data in mm and (inches)

### 10.1.5 Mounting

#### Installation

1. Tilt the component backwards slightly and attach it to the DIN rail using the hooks.
2. Swivel the component onto the DIN rail until you hear the mounting slide at the rear latch into position.
3. Slide the components along the mounting rail to either the left or right up to their final position.

## Removal

1. First shift the mounting slide downwards at the lug to release the interlocking with the mounting rail.
2. Swivel the component to the front and withdraw it upwards from the DIN rail.

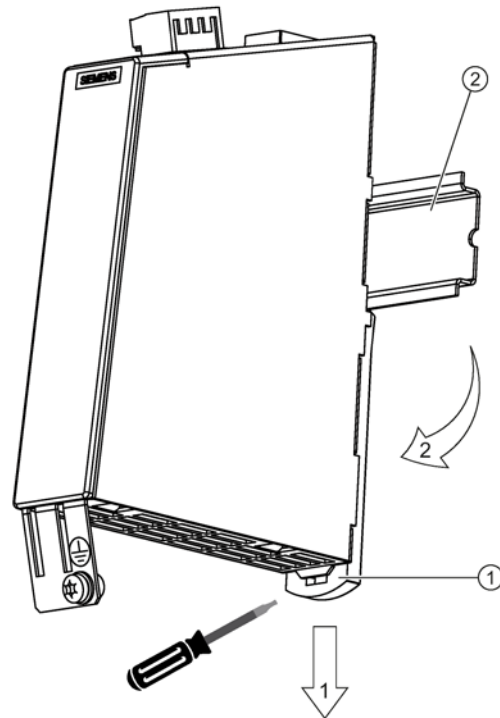

- ① Mounting slide
- ② Mounting rail

Figure 10-3 Removing from a DIN mounting rail

### 10.1.6 Technical data

Table 10- 5 Technical data

6SL3055-0AA00-5BA.	Unit	Value
<b>Electronics power supply</b>		
Voltage	V <sub>DC</sub>	24 (20.4 ... 28.8)
Current (without encoder system)	A <sub>DC</sub>	≤ 0.20
Current (with encoder system)	A <sub>DC</sub>	≤ 0.35
Power loss	W	≤ 10
<b>Encoder system power supply</b>		
Voltage	V <sub>DC</sub>	5 V DC (with remote sense) <sup>1)</sup>
Current	A <sub>DC</sub>	0.35
Encoder frequency that can be evaluated (f <sub>en-coder</sub> )	kHz	≤ 500
SSI baud rate <sup>2)</sup>	kHz	100 ... 1000 <sup>3)</sup>
Max. encoder cable length	m	100
PE/ground connection		At the housing with M4/1.8 Nm screw
Weight	kg	0.45
Degree of protection		IP20 or IPXXB

- 1) A controller compares the encoder system supply voltage - sensed via the remote sense cables - with the reference supply voltage of the encoder system, and adjusts the supply voltage for the encoder system at the output of the sensor module until the required supply voltage is obtained directly at the encoder system.
- 2) Only possible for SSI encoders with 5 V supply.
- 3) See the diagram "Maximum cable length depending on the SSI baud rate for SSI encoders"

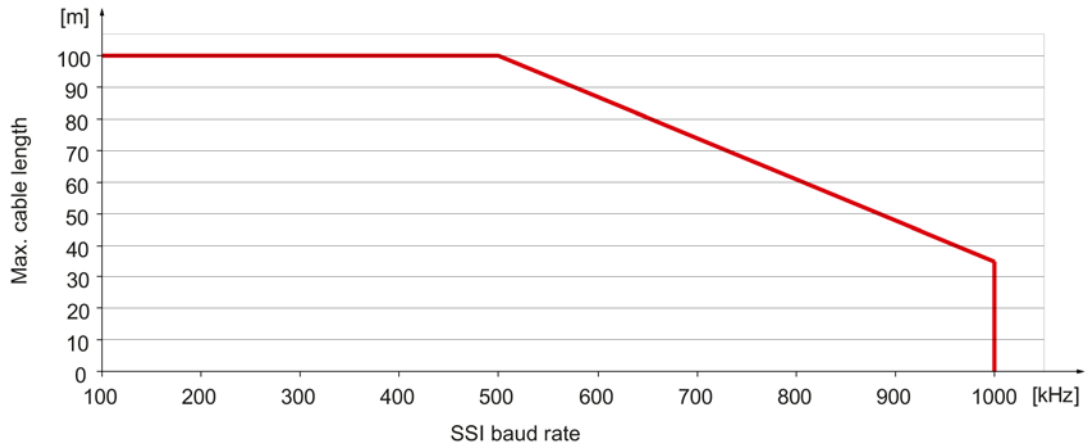

Figure 10-4 Maximum cable length depending on the SSI baud rate for SSI encoders

## **10.2 Sensor Module Cabinet-Mounted SMC30**

### **10.2.1 Description**

The Sensor Module Cabinet-Mounted SMC30 evaluates encoder signals and transmits the speed, actual position value and, if necessary, the motor temperature and reference point via DRIVE-CLiQ to the S120 Combi.

The SMC30 is used to evaluate encoder signals from encoders with TTL, HTL, or SSI interfaces.

A combination of TTL/HTL signal and SSI absolute signal is possible at terminals X521/X531, if both signals are derived from the same measured variable.

## 10.2.2 Interface description

### 10.2.2.1 Overview

X500  
DRIVE-CLiQ interface

X524  
Electronics power supply

LEDs

X520  
Encoder system interface  
HTL, TTL with  
Track monitoring,  
SSI

Alternative encoder system  
Interface  
HTL, TTL with  
Track monitoring,  
SSI

Protective conductor connection  
M4 / 1.8 Nm

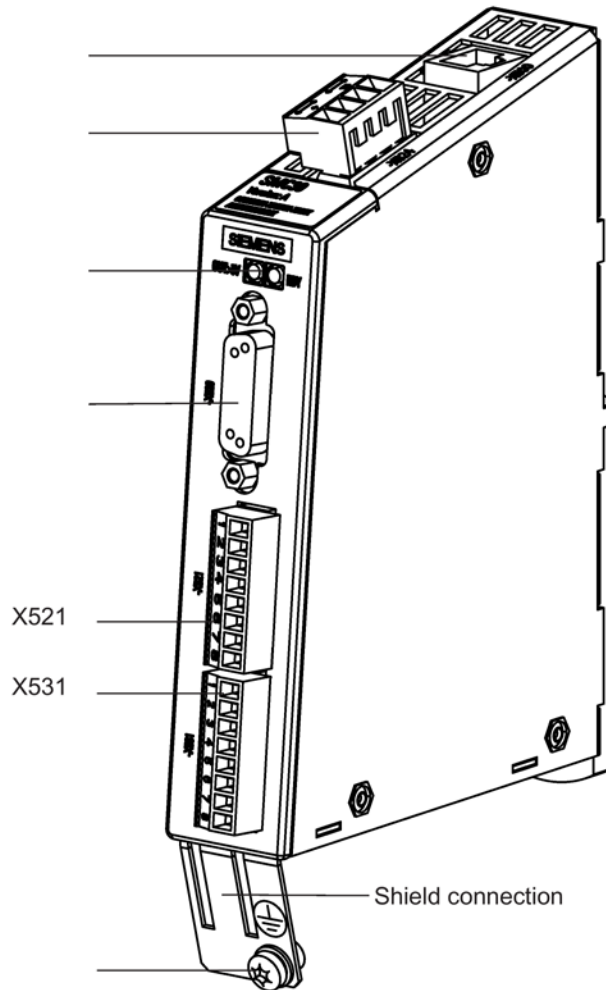
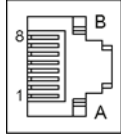

Figure 10-5 Interface description of the SMC30



### 10.2.2.2 X500 DRIVE-CLiQ interface

Table 10- 6 X500: DRIVE-CLiQ interface

	Pin	Signal name	Technical data
	1	TXP	Transmit data +
	2	TXN	Transmit data -
	3	RXP	Receive data +
	4	Reserved, do not use	
	5	Reserved, do not use	
	6	RXN	Receive data -
	7	Reserved, do not use	
	8	Reserved, do not use	
	A	Reserved, do not use	
	B	M (0 V)	Electronics ground
Connector type	DRIVE-CLiQ socket		

The blanking cover for the DRIVE-CLiQ port is included in the scope of delivery.

Blanking covers (50 x) Article number: 6SL3066-4CA00-0AA0

### 10.2.2.3 X520 encoder system interface

Table 10- 7 X520: Encoder system interface

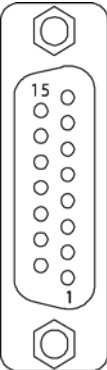
	Pin	Signal name	Technical data
	1	+Temp	Motor temperature sensing KTY84-1C130 (KTY+) Temperature sensor KTY84-1C130/PTC
	2	Clock	SSI clock
	3	Clock*	Inverse SSI clock
	4	P encoder 5 V / 24 V	Encoder power supply
	5	P encoder 5 V / 24 V	
	6	P sense	Sense input of encoder power supply
	7	M encoder (M)	Ground for encoder power supply
	8	- Temp	Motor temperature sensing KTY84-1C130 (KTY-) Temperature sensor KTY84-1C130/PTC
	9	M sense	Ground sense input
	10	R	Reference signal R
	11	R*	Inverse reference signal R
	12	B*	Inverse incremental signal B
	13	B	Incremental signal B
	14	A* / data*	Inverted incremental signal A/inverted SSI data
	15	A / data	Incremental signal A/SSI data
Connector type:	15-pin Sub-D socket		
Measuring current via temperature sensor connection: 2 mA			

**NOTICE**

**Damage to the encoder due to incorrect supply voltage**

The encoder supply can be parameterized to 5 V or 24 V. The sensor may be destroyed if you enter the wrong parameters.

- Select the appropriate supply voltage.

**NOTICE**

**Damage to motor in the event of incorrectly connected KTY temperature sensor**

A KTY temperature sensor connected with incorrect polarity cannot detect if the motor overheats. Overheating can cause damage to the motor.

- Connect a KTY temperature sensor with the correct polarity.

You can find information for parameterizing the KTY temperature sensor in the SINAMICS S120 Function Manual (FH1) in Chapter "Monitoring and protective functions/thermal motor monitoring".



**! WARNING**

**Danger to life due to electric shock in the event of voltage flashovers at the temperature sensor**

Voltage flashovers in the signal electronics can occur in motors without safe electrical separation of the temperature sensors.

- Use temperature sensors that comply with the specifications relating to protective separation.
- If safe electrical separation cannot be guaranteed (for linear motors or third-party motors, for example), use a Sensor Module External (SME120 or SME125) or Terminal Module TM120.

### 10.2.2.4 X521 / X531 alternative encoder system interface

Table 10- 8 X521/X531: Alternative encoder system interface

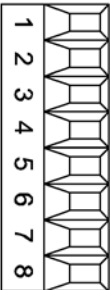
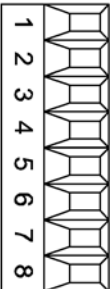
	Pin	Designation	Technical data
	1	A	Incremental signal A
	2	A*	Inverse incremental signal A
	3	B	Incremental signal B
	4	B*	Inverse incremental signal B
	5	R	Reference signal R
	6	R*	Inverse reference signal R
	7	CTRL	Control signal
	8	M	Ground
	1	P_Encoder 5 V / 24 V	Encoder power supply
	2	M_Encoder	Ground for encoder power supply
	3	-Temp	Motor temperature sensing KTY84-1C130 (KTY-) Temperature sensor KTY84-1C130/PTC
	4	+Temp	Motor temperature sensing KTY84-1C130 (KTY+) Temperature sensor KTY84-1C130/PTC
	5	Clock	SSI clock
	6	Clock*	Inverse SSI clock
	7	Data	SSI data
	8	Data*	Inverse SSI data
Max. connectable cross-section: 1.5 mm <sup>2</sup> Measuring current via the temperature sensor connection: 2 mA When unipolar HTL encoders are used, A*, B*, and R* on the terminal block must be jumpered with M_Encoder (X531) <sup>1)</sup> .			

<sup>1)</sup> Because the physical transmission media is more robust, the bipolar connection should always be used. The unipolar connection should only be used if the encoder type does not output push-pull signals.



**WARNING**

**Danger to life through electric shock due to unconnected cable shields**

Hazardous touch voltages can occur through capacitive cross-coupling due to unconnected cable shields.

- Attach the cable shield to the component for the encoder system connection at the terminals.

**Temperature sensor connection**

**NOTICE**

**Damage to motor in the event of incorrectly connected KTY temperature sensor**

A KTY temperature sensor connected with incorrect polarity cannot detect if the motor overheats. Overheating can cause damage to the motor.

- Connect a KTY temperature sensor with the correct polarity.

You can find information for parameterizing the KTY temperature sensor in the SINAMICS S120 Function Manual (FH1) in Chapter "Monitoring and protective functions/thermal motor monitoring".

**Note**

The maximum length of the temperature sensor cable is 100 m. The cables must be shielded.



**! WARNING**

**Danger to life due to electric shock in the event of voltage flashovers at the temperature sensor**

Voltage flashovers in the signal electronics can occur in motors without safe electrical separation of the temperature sensors.

- Use temperature sensors that comply with the specifications regarding safe electrical separation.
- If safe electrical separation cannot be guaranteed (for linear motors or third-party motors, for example), use a Sensor Module External (SME120 or SME125) or Terminal Module TM120.

### 10.2.2.5 X524 Electronics power supply

Table 10- 9 X524: Electronics power supply

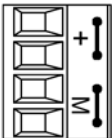
	Terminal	Function	Technical data
	+	Electronics power supply	Voltage: 24 V (20.4 ... 28.8 V) Current consumption: max. 0.55 A Max. current via jumper in connector: 20 A Type: Screw terminal 2 (Page 307) Max. connectable cross-section: 2.5 mm <sup>2</sup> Tightening torque: 0.22 ... 0.25 Nm
	+	Electronics power supply	
	M	Electronics ground	
	M	Electronics ground	

#### Note

The two "+" and "M" terminals are jumpered in the connector. This ensures that the supply voltage is looped through.

## 10.2.3 Meaning of the LEDs

### 10.2.3.1 Meaning of LEDs on the Sensor Module Cabinet-Mounted SMC30

Table 10- 10 Meaning of LEDs on the Sensor Module Cabinet SMC30

LED	Color	Status	Description, cause	Remedy
RDY READY	–	Off	The electronics power supply is missing or outside the permissible tolerance range.	–
	Green	Continuous light	The component is ready for operation. Cyclic DRIVE-CLiQ communication is taking place.	–
	Orange	Continuous light	DRIVE-CLiQ communication is being established.	–
	Red	Continuous light	This component has at least one fault. <b>Note:</b> LED is controlled irrespective of the corresponding messages being reconfigured.	Remedy and acknowledge fault
	Green / Red	0.5 Hz flashing light	Firmware is being downloaded.	–
	Green / Red	2 Hz flashing light	Firmware download is complete. Wait for POWER ON.	Carry out a POWER ON
	Green / Orange or Red / Orange	Flashing light	Component recognition via LED is activated. This function is parameterizable (see SINAMICS S120/S150 List Manual). <b>Note:</b> Both options depend on the LED status when component recognition is activated.	–
OUT > 5 V	–	Off	Electronic power supply is missing or outside permissible tolerance range. Power supply $\leq$ 5 V.	–
	Orange	Continuous light	Electronics power supply for encoder system available. Power supply > 5 V. <b>Notice</b> Make sure that the connected encoder can be operated with a 24 V power supply. If an encoder that is designed for a 5 V supply is operated with a 24 V supply, this can destroy the encoder electronics.	–

### 10.2.3.2 Cause and rectification of faults

#### Cause and rectification of faults

The following documents contain information about the cause of faults and how they can be rectified:

SINAMICS S120 Commissioning Manual (IH1)

SINAMICS S120/S150, List Manual (LH1)

### 10.2.4 Dimension drawing

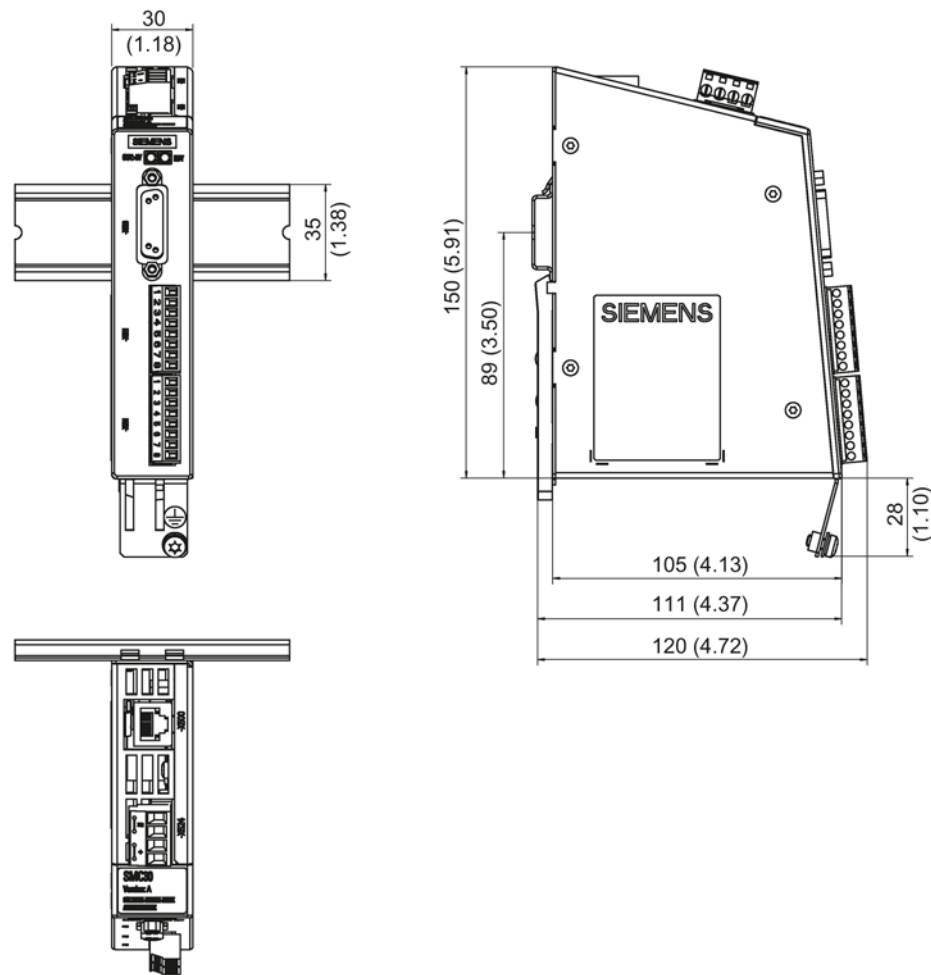

Figure 10-6 Dimension drawing of the Sensor Module Cabinet SMC30, all data in mm and (inches)

## 10.2.5 Mounting

### Installation

1. Tilt the component backwards slightly and attach it to the DIN rail using the hooks.
2. Swivel the component onto the DIN rail until you hear the mounting slide at the rear latch into position.
3. Slide the components along the mounting rail to either the left or right up to their final position.

### Removal

1. First shift the mounting slide downwards at the lug to release the interlocking with the mounting rail.
2. Swivel the component to the front and withdraw it upwards from the DIN rail.

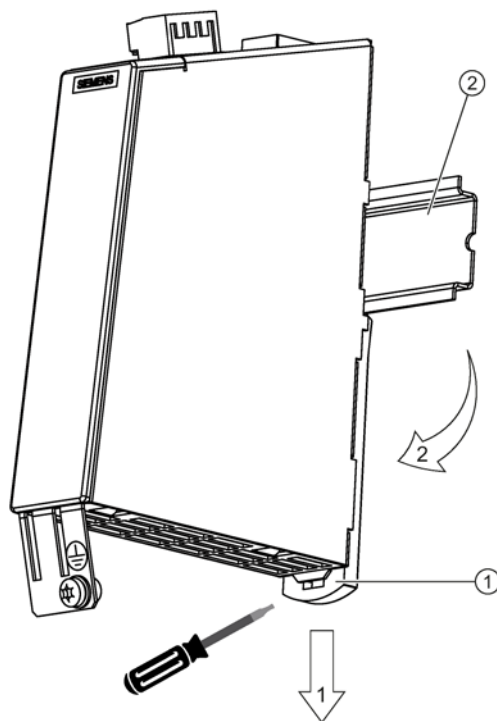

- ① Mounting slide
- ② Mounting rail

Figure 10-7 Removing from a DIN mounting rail



## 10.2.6 Protective conductor connection and shield support

Shield contacts are only required if the system is connected to X521/X531.

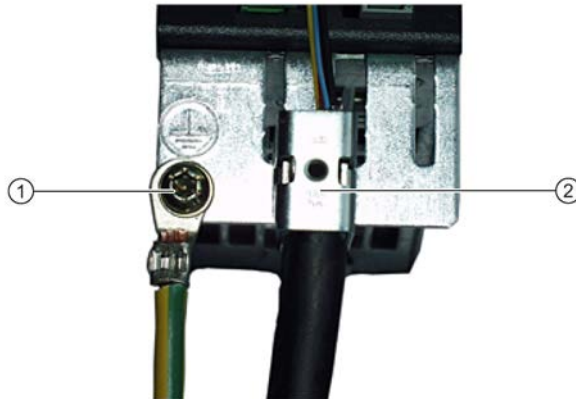

- ① Protective conductor connection M4 / 1.8 Nm
- ② Shield connection terminal, Weidmüller company, type: KLBÜ CO1, Article No.: 1753311001

Figure 10-8 Shield support and protective conductor connection

The bending radii of the cables must be taken into account (see MOTION-CONNECT description).

### NOTICE

#### Damage or faulty operation due to incorrect shielding or inadmissible cable lengths

If the correct shielding procedures or the permissible cable lengths are not observed, it can cause damage or the machine may malfunction.

- Only use shielded cables.
- Do not exceed the cable lengths stated in the technical data.

## 10.2.7 Technical data

Table 10- 11 Technical data

6SL3055-0AA00-5CA.	Unit	Value
<b>Electronics power supply</b>		
Voltage	V <sub>DC</sub>	24 (20.4 ... 28.8)
Current (without encoder system)	A <sub>DC</sub>	≤ 0.20
Current (with encoder system)	A <sub>DC</sub>	≤ 0.55
Power loss	W	≤ 10
<b>Encoder system power supply</b>		
Voltage	V <sub>DC</sub>	5 (with or without remote sense) <sup>1)</sup> or V <sub>DC</sub> - 1 V
Current	A <sub>DC</sub>	0.35
Encoder frequency that can be evaluated (f <sub>encoder</sub> )	kHz	≤ 300
SSI baud rate	kHz	100 ... 1000 <sup>2)</sup>
PE/ground connection		At the housing with M4/1.8 Nm screw
Weight		0.45
Degree of protection		IP20 or IPXXB

1) A controller compares the encoder system supply voltage - sensed via the Remote Sense cables - with the reference supply voltage of the encoder system, and adjusts the supply voltage for the encoder system at the output of the sensor module until the required supply voltage is obtained directly at the encoder system (only for 5 V encoder system power supply). Remote Sense only to X520.

2) See the diagram "Maximum cable length depending on the SSI baud rate for SSI encoders"

## Connectable encoder systems

Table 10- 12 Specification of encoder systems that can be connected

Parameter	Designation	Threshold	Min.	Max.	Unit
High signal level (TTL bipolar at X520 or X521/X531) <sup>1)</sup>	U <sub>Hdiff</sub>		2	5	V
Low signal level (TTL bipolar at X520 or X521/X531) <sup>1)</sup>	U <sub>Ldiff</sub>		-5	-2	V
High signal level (HTL unipolar)	U <sub>H</sub> <sup>3)</sup>	High	17	V <sub>CC</sub>	V
		Low	10	V <sub>CC</sub>	V
Low signal level (HTL unipolar)	U <sub>L</sub> <sup>3)</sup>	High	0	7	V
		Low	0	2	V
High signal level (HTL bipolar) <sup>2)</sup>	U <sub>Hdiff</sub>		3	V <sub>CC</sub>	V
Low signal level (HTL bipolar) <sup>2)</sup>	U <sub>Ldiff</sub>		-V <sub>CC</sub>	-3	V
High signal level (SSI bipolar at X520 or X521/X531) <sup>1)</sup>	U <sub>Hdiff</sub>		2	5	V
Low signal level (SSI bipolar at X520 or X521/X531) <sup>1)</sup>	U <sub>Ldiff</sub>		-5	-2	V
Signal frequency	f <sub>s</sub>		-	300	kHz

Parameter	Designation	Threshold	Min.	Max.	Unit
Edge clearance	$t_{\min}$		100	-	ns
"Zero pulse inactive time" (before and after A=B=high)	$t_{Lo}$		640	$(t_{ALo-BHi} - t_{Hi})/2^{4)}$	ns
"Zero pulse active time" (while A=B=high and beyond) <sup>5)</sup>	$t_{Hi}$		640	$t_{ALo-BHi} - 2 \cdot t_{Lo}^{4)}$	ns

- 1) Other signal levels according to the RS 422 standard.
- 2) The absolute level of the individual signals varies between 0 V and VCC of the encoder system.
- 3) Only with Article No. 6SL3055-0AA00-5CA2 and firmware version 2.5 SP1 or higher can this value be configured using software. For older firmware releases and Article Nos. less than 6SL3055-0AA00-5CA2, the "low" threshold applies.
- 4)  $t_{ALo-BHi}$  is not a specified value, but is the time between the falling edge of track A and the next but one rising edge of track B.
- 5) Additional information on setting the "Zero pulse active time" can be found in the manual: SINAMICS S120, Function Manual, tolerant encoder monitoring for SMC30

Table 10- 13 Encoders that can be connected

	X520 (SUB-D)	X521 (terminal)	X531 (terminal)	Track monitoring	Remote Sense <sup>2)</sup>
HTL bipolar 24 V	Yes	Yes		Yes	No
HTL unipolar 24 V <sup>1)</sup>	Yes	Yes (however, a bipolar connection is recommended) <sup>1)</sup>		No	No
TTL bipolar 24 V	Yes	Yes		Yes	No
TTL bipolar 5 V	Yes	Yes		Yes	At X520
SSI 24 V/5 V	Yes	Yes		No	No
TTL unipolar	No				

- 1) Because the physical transmission media is more robust, the bipolar connection should always be used. The unipolar connection should only be used if the encoder type does not output push-pull signals.
- 2) A controller compares the encoder system supply voltage - sensed via the Remote Sense cables - with the reference supply voltage of the encoder system, and adjusts the supply voltage for the encoder system at the output of the sensor module until the required supply voltage is obtained directly at the encoder system (only for 5 V encoder system power supply).

### Maximum encoder cable lengths

Table 10- 14 Maximum encoder cable length

Encoder type	Maximum encoder cable length in m
TTL <sup>1)</sup>	100
HTL unipolar <sup>2)</sup>	100
HTL bipolar	300
SSI	100 <sup>3)</sup>

- 1) For TTL encoders at X520 → remote sense → 100 m
- 2) Because the physical transmission media is more robust, the bipolar connection should always be used. The unipolar connection should only be used if the encoder type does not output push-pull signals.
- 3) See the diagram "Maximum cable length depending on the SSI baud rate for SSI encoders"

#### SSI encoder

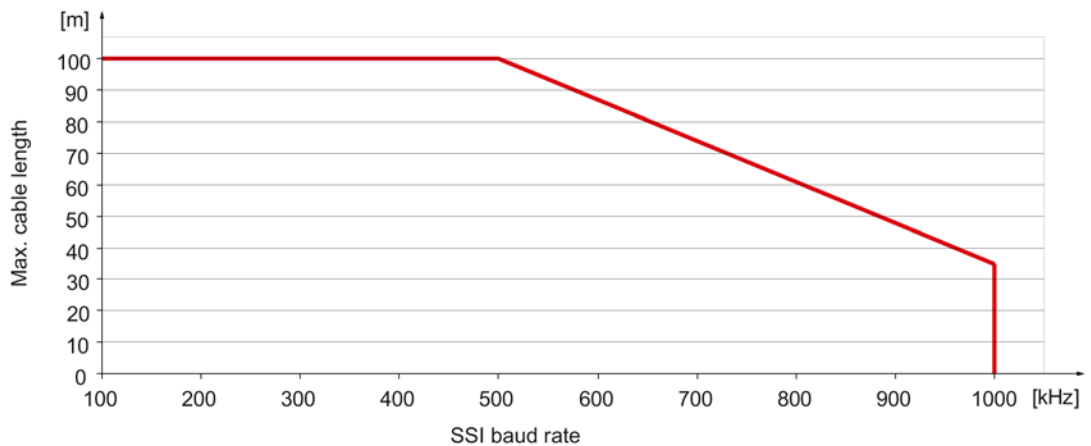

Figure 10-9 Maximum cable length depending on the SSI baud rate for SSI encoders

#### Encoders with 5 V supply without remote sense connected at X521/X531

For encoders with a 5 V supply at X521/X531, the encoder current drawn depends on the cable length (for 0.5 mm<sup>2</sup> cable cross-sections):

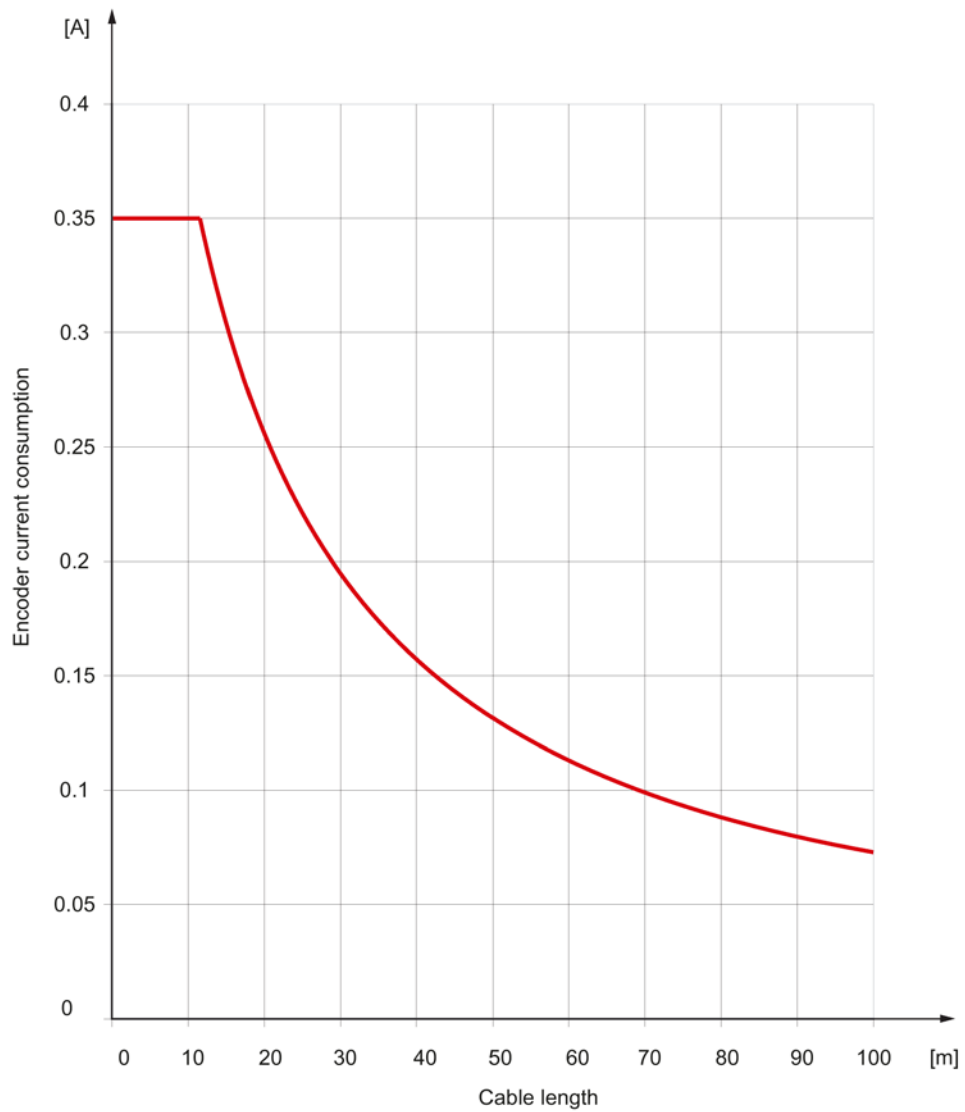

Figure 10-10 Max. cable length as a function of the encoder current drawn

#### Encoders without remote sense

For encoders without Remote Sense, the permissible cable length is restricted to 100 m. Reason: The voltage drop depends on the cable length and the encoder current.

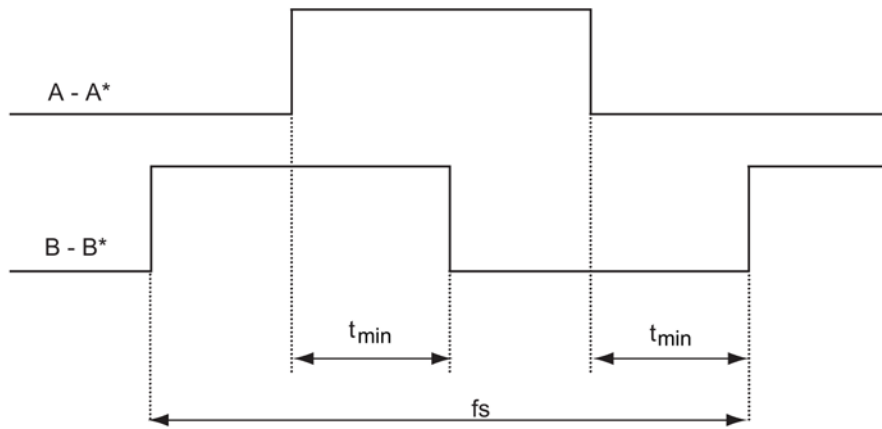

Figure 10-11 Signal characteristic of track A and track B between two edges: Time between two edges with pulse encoders

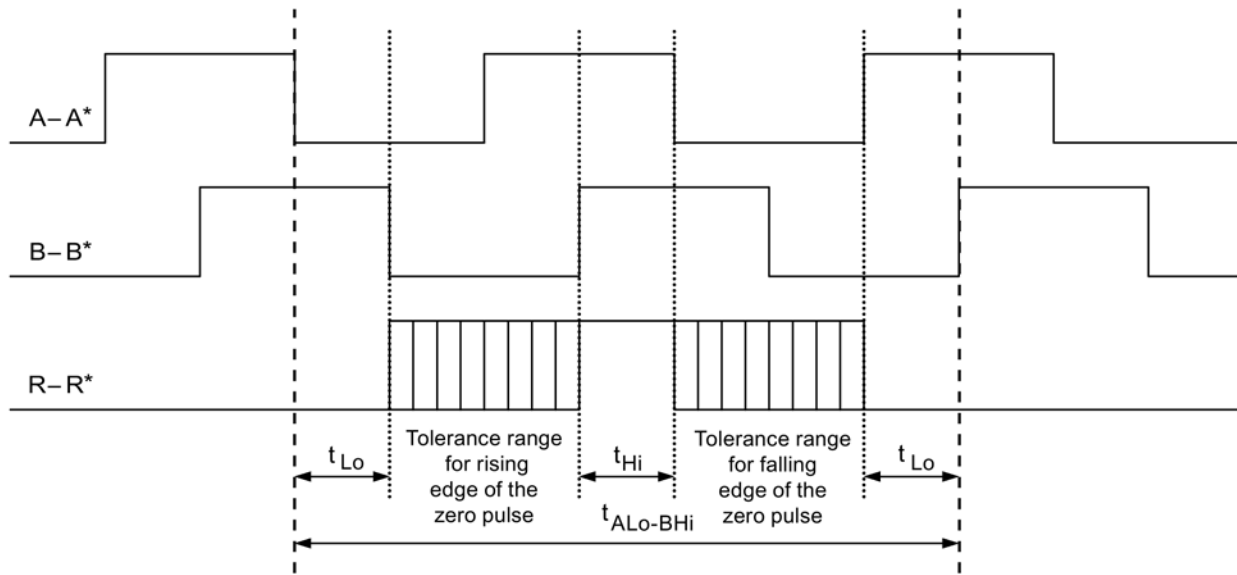

Figure 10-12 Position of the zero pulse to the track signals

## 10.3 Sensor Module External SME20

### 10.3.1 Description

Direct encoder systems outside the cabinet can be connected to the Sensor Module External SME20. The SME20 evaluates these encoder systems and converts the calculated values to DRIVE-CLiQ.

Incremental direct encoder systems with SIN/COS (1 Vpp) and reference signal can be connected.

It is possible to connect a motor with a 17-pole round connector for the encoder to the 12-pole circular connector of the SME20 using adapter cable 6FX 8002-2CA88-.....

- KTY/PTC temperature sensors can be used for evaluation of the motor temperature.
- The Sensor Module is only suitable for motors without absolute track signals (C/D track):
  - Induction motors (e.g. 1PH)
  - Synchronous motors with pole position identification (e.g. 1FN, 1FW, 1FE)

Neither motor nor encoder data are saved in the SME20.

### 10.3.2 Safety Information



#### WARNING

**Danger to life due to electric shock in the event of voltage flashovers at the temperature sensor**

Voltage flashovers in the signal electronics can occur in motors without safe electrical separation of the temperature sensors.

- Only use temperature sensors that fully comply with the specifications of the safety isolation.
- If safe electrical separation cannot be guaranteed (for linear motors or third-party motors, for example), use a Sensor Module External (SME120 or SME125) or Terminal Module TM120.

### 10.3.3 Interface description

#### 10.3.3.1 Overview

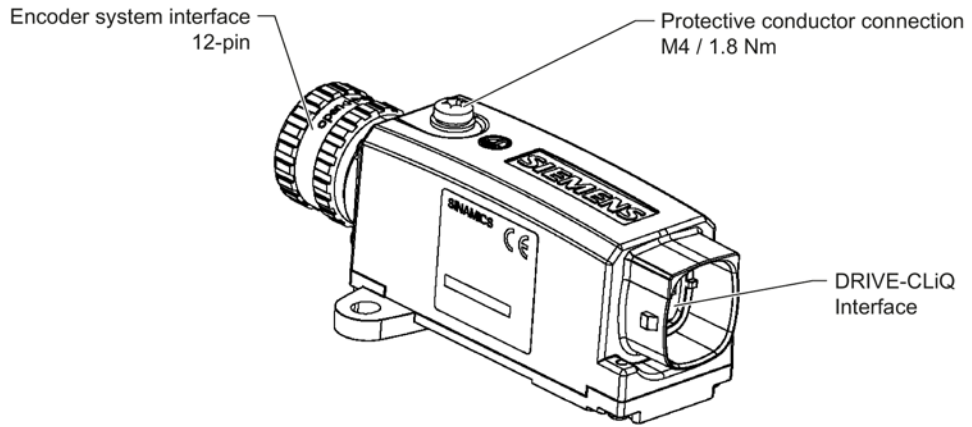

Figure 10-13 Interface description SME20

#### 10.3.3.2 Connection example

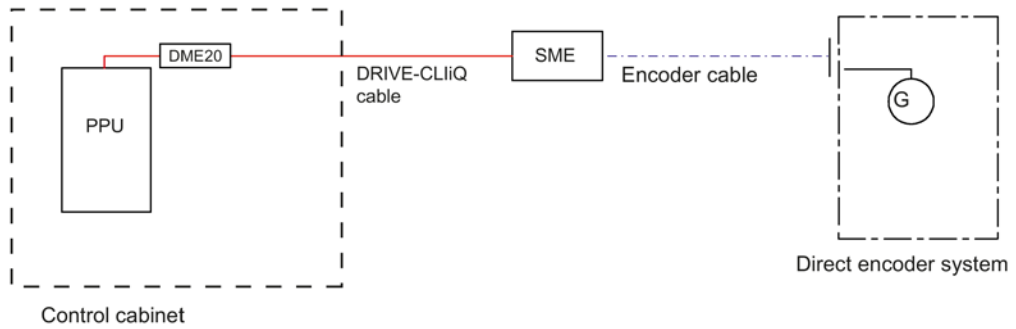
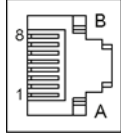

Figure 10-14 Connection of a direct encoder system via a Sensor Module External (SME)



### 10.3.3.3 DRIVE-CLiQ interface

Table 10- 15 DRIVE-CLiQ interface

	Pin	Signal name	Technical data
	1	TXP	Transmit data +
	2	TXN	Transmit data -
	3	RXP	Receive data +
	4	Reserved, do not use	
	5	Reserved, do not use	
	6	RXN	Receive data -
	7	Reserved, do not use	
	8	Reserved, do not use	
	A	+ (24 V)	Power supply
	B	M (0 V)	Electronics ground
Connector type	DRIVE-CLiQ socket		
Power consumption max. 0.25 A			

The blanking cover for the DRIVE-CLiQ port to secure the degree of protection IP 67 is not included in the scope of delivery.

Blanking covers (6 units), article number: 6SL3066-4CA01-0AA0

#### Note

Only MOTION-CONNECT DRIVE-CLiQ cables may be used for connections. The maximum cable length is 100 m for MOTION-CONNECT 500, and 75 m for MOTION-CONNECT 800PLUS cables.

## 10.3.3.4 Encoder system interface

Table 10- 16 Encoder system interface SME20

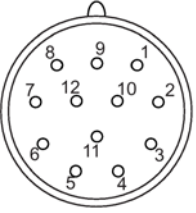
	Pin	Signal name	Technical data
	1	B*	Inverse incremental signal B
	2	P5	Encoder power supply
	3	R	Reference signal R
	4	R*	Inverse reference signal R
	5	A	Incremental signal A
	6	A*	Inverse incremental signal A
	7	-Temp <sup>1) 2)</sup>	Temperature sensor connection <sup>3)</sup> KTY84-1C130 / PT1000 / PTC
	8	B	Incremental signal B
	9	+Temp <sup>1) 2)</sup>	Temperature sensor connection <sup>3)</sup> KTY84-1C130 / PT1000 / PTC
	10	M	Ground, encoder power supply
	11	M	Ground, encoder power supply
	12	P5	Encoder power supply
Connector kit:	12 pole, article number: 6FX2003-0SA12		
Measuring current via temperature sensor connection: 2 mA Blanking cover for encoder system interface: Pöppelmann GmbH & Co. KG, Lohne, Article number: GPN 300 F211			

<sup>1)</sup> These connections do not have protective separation!

<sup>2)</sup> Accuracy of the temperature measurement:

- KTY:  $\pm 7$  °C (including evaluation)
- PT1000:  $\pm 5$  °C (PT1000 tolerance class B according to DIN EN 60751 including evaluation)
- PTC:  $\pm 5$  °C (including evaluation)

<sup>3)</sup> Connecting cable: Article number 6FX8002-2CA88-....

**NOTICE**

**Damage to motor in the event of incorrectly connected KTY temperature sensor**

If a KTY temperature sensor is connected with incorrect polarity, it is not possible to detect when the motor overheats. Overheating can cause damage to the motor.

- Connect a KTY temperature sensor with the correct polarity.



**! WARNING**

**Danger to life due to electric shock in the event of voltage flashovers at the temperature sensor**

Voltage flashovers in the signal electronics can occur in motors without safe electrical separation of the temperature sensors.

- Use temperature sensors that comply with the specifications relating to protective separation.
- If safe electrical separation cannot be guaranteed (for linear motors or third-party motors, for example), use a Sensor Module External (SME120 or SME125) or Terminal Module TM120.

**10.3.4 Dimension drawing**

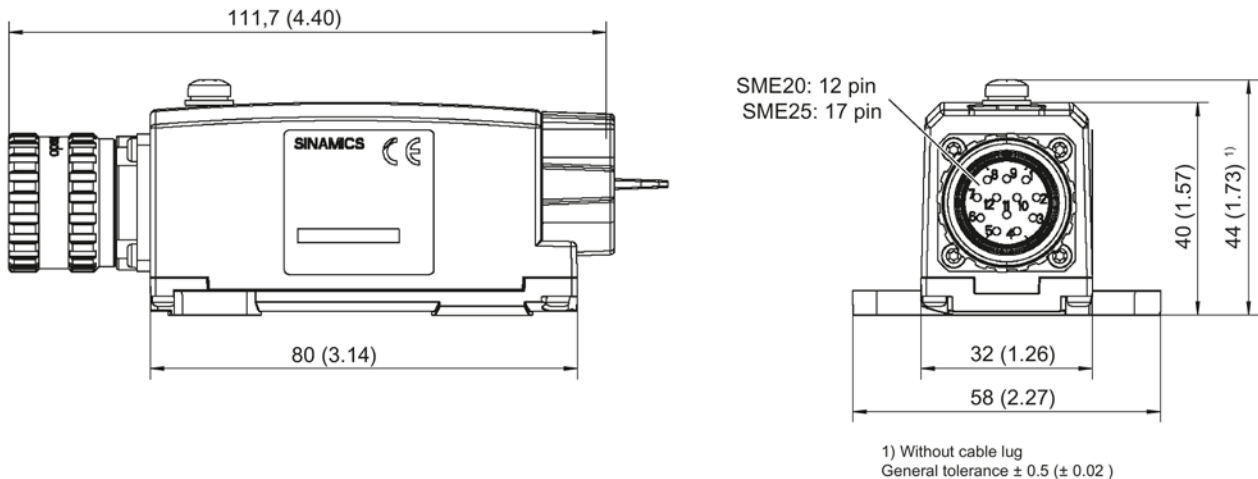
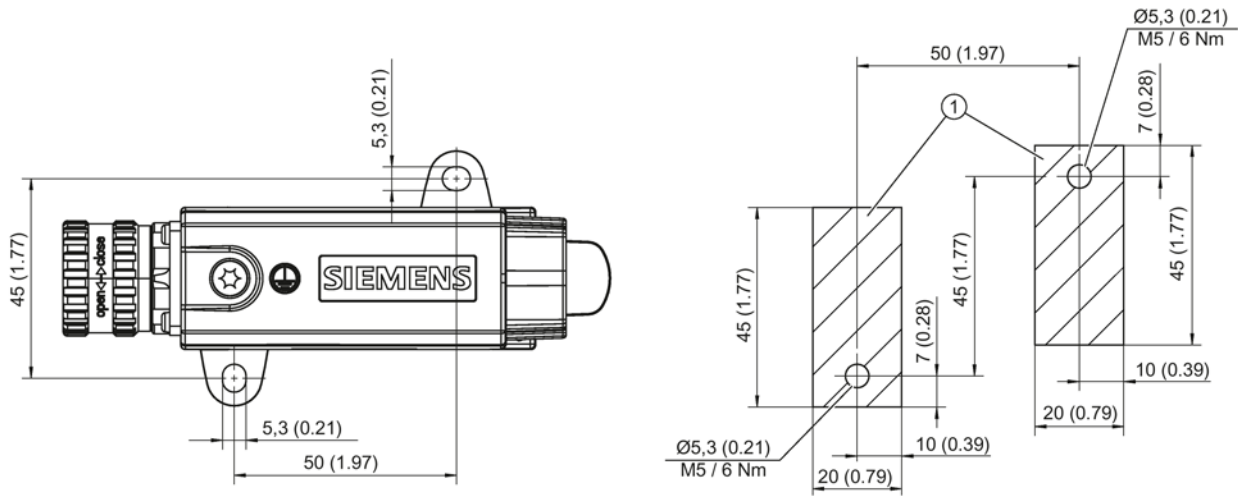

Figure 10-15 Dimension drawing of the Sensor Module External SME20, all data in mm and (inches)  
Article number 6SL3055-0AA00-5EA3

### 10.3.5 Installation



① Contact surface

Figure 10-16 Drilling pattern for installing the SME20/SME25

#### Installation

1. Place the drilling pattern on the mounting surface. Make sure that the contact surface is bare, unpainted metal.
2. Drill two holes with Ø 5.3 or M5 threaded holes according to the drilling pattern.
3. Fix the Sensor Module to the mounting surface. The tightening torque is 6 Nm.

### 10.3.6 Technical data

Table 10- 17 Technical data

6SL3055-0AA00-5EA3	Unit	Value
Electronics power supply		
Voltage	V <sub>DC</sub>	24 (20.4 ... 28.8)
Current (without encoder system)	A <sub>DC</sub>	≤ 0.15
Current (with encoder system)	A <sub>DC</sub>	≤ 0.25
Power loss	W	≤ 4
Encoder system power supply		
Voltage	V <sub>DC</sub>	5
Current	A <sub>DC</sub>	0.35
Encoder frequency that can be evaluated ( $f_{\text{encoder}}$ )	kHz	≤ 500
PE/ground connection		At the housing with M4/1.8 Nm screw
Weight	kg	0.31
Degree of protection		IP67

The maximum cable length at the encoder system interface depends on the current consumption of the encoder system and the cross-section of the supply cores in the cable. However, the maximum length is 10 m.

For encoder systems that operate in a supply voltage range from 4.75 V to 5.25 V, the following diagram is obtained. The sample parameters shown are 0.28 mm<sup>2</sup> cross-section (0.14 mm<sup>2</sup> supply cores plus 0.14 mm<sup>2</sup> remote sense conductors) and 0.64 mm<sup>2</sup> (0.5 mm<sup>2</sup> supply conductors plus 0.14 mm<sup>2</sup> remote sense conductors).

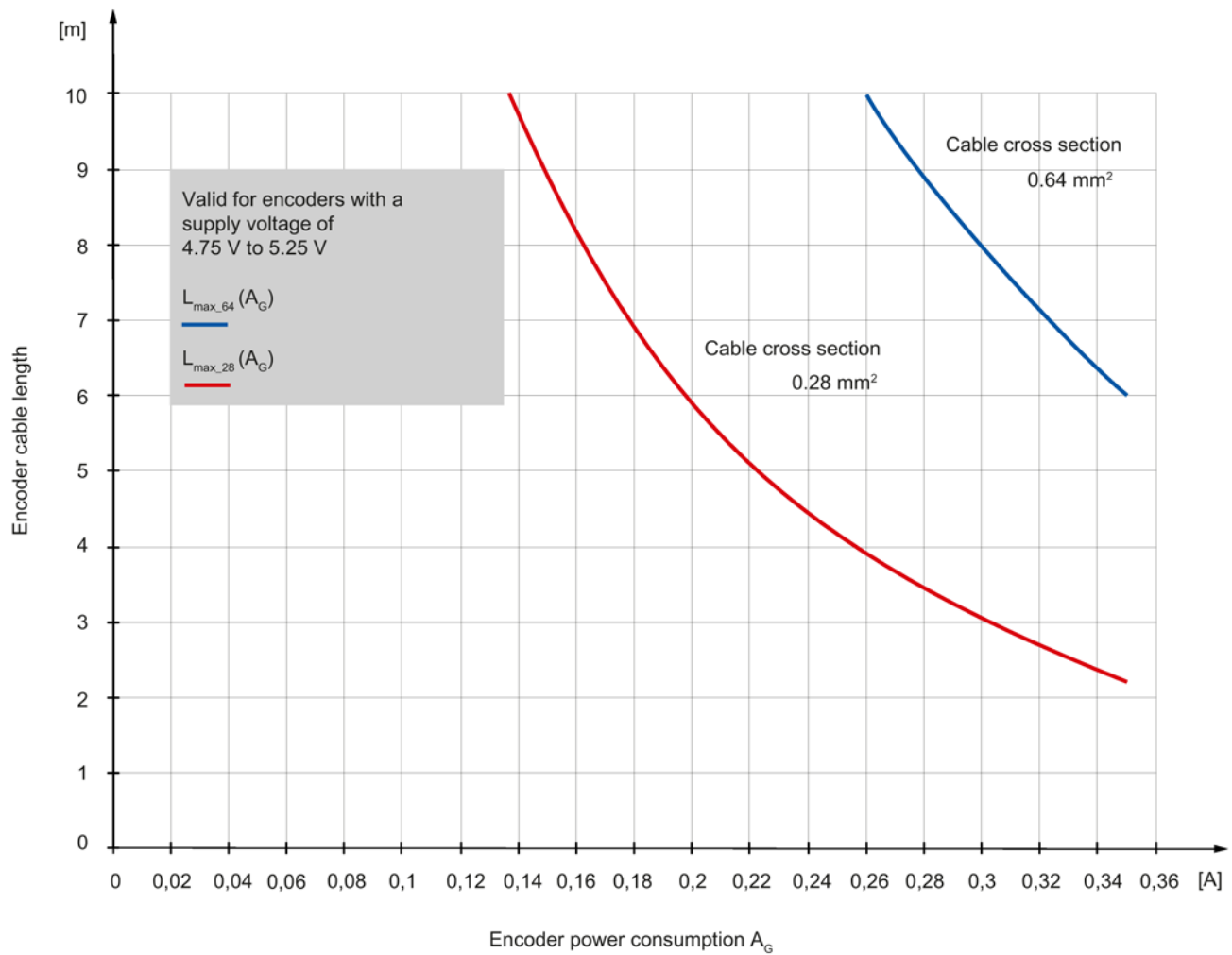

Figure 10-17 Max. cable length as a function of the current drawn by the encoder system

In addition to the encoder systems for a supply voltage range of 4.75 V to 5.25 V in the figure above, encoder systems are also available for an extended range down to 3.6 V. These can be generally operated using encoder system cables up to 10 m long provided that the total cross-section of the supply core plus Remote Sense cores does not fall below 0.14 mm<sup>2</sup>.

## 10.4 Sensor Module External SME25

### 10.4.1 Description

Direct encoder systems outside the cabinet can be connected to the Sensor Module External SME25. The SME25 evaluates these encoder systems and converts the calculated values to DRIVE-CLiQ.

Direct encoder systems with EnDat 2.1 or SSI with SIN/COS (1 Vpp) incremental signals can be connected, however without reference signal.

Neither motor nor encoder data are saved in the SME25.

### 10.4.2 Interface description

#### 10.4.2.1 Overview

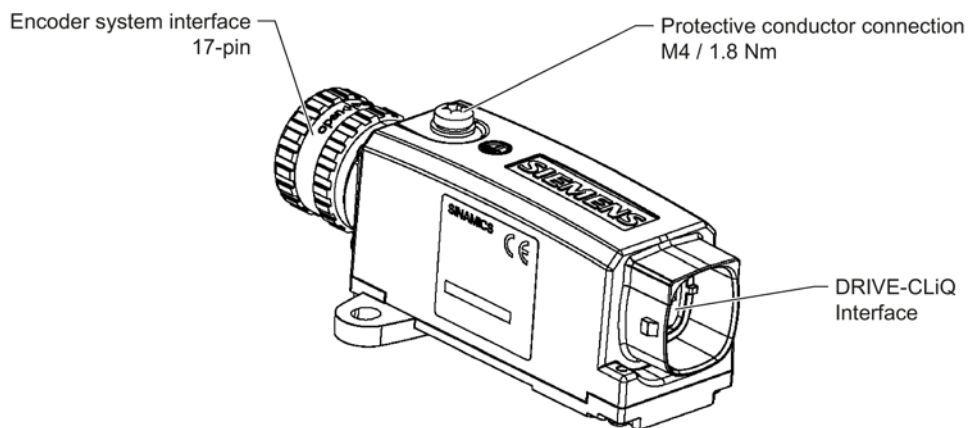

Figure 10-18 Interface description SME25

10.4.2.2 Connection example

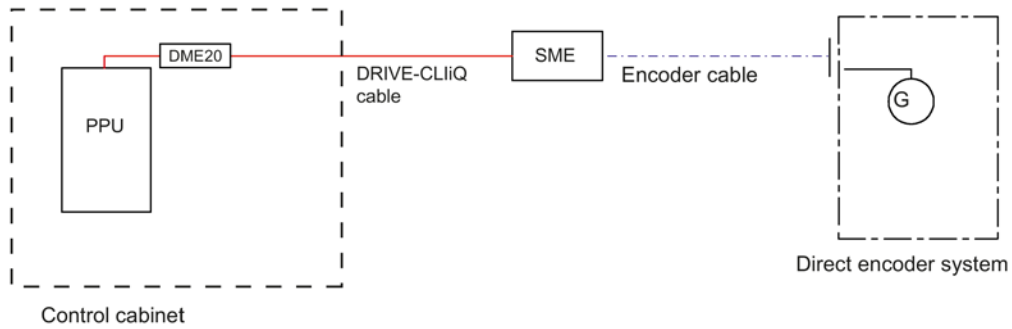

Figure 10-19 Connection of a direct encoder system via a Sensor Module External (SME)

10.4.2.3 DRIVE-CLiQ interface

Table 10- 18 DRIVE-CLiQ interface

	Pin	Signal name	Technical data
	1	TXP	Transmit data +
	2	TXN	Transmit data -
	3	RXP	Receive data +
	4	Reserved, do not use	
	5	Reserved, do not use	
	6	RXN	Receive data -
	7	Reserved, do not use	
	8	Reserved, do not use	
	A	+ (24 V)	Power supply
	B	M (0 V)	Electronics ground
Connector type	DRIVE-CLiQ socket		
Power consumption max. 0.25 A			

The blanking cover for the DRIVE-CLiQ port to secure the degree of protection IP 67 is not included in the scope of delivery.

Blanking covers (6 units), article number: 6SL3066-4CA01-0AA0

**Note**

Only MOTION-CONNECT DRIVE-CLiQ cables may be used for connections. The maximum cable length is 100 m for MOTION-CONNECT 500, and 75 m for MOTION-CONNECT 800PLUS cables.



### 10.4.2.4 Encoder system interface

Table 10- 19 Encoder system interface SME25

	Pin	Signal name	Technical specifications
	1	P5	Encoder power supply
	2	Reserved, do not use	
	3	Reserved, do not use	
	4	M	Ground for encoder power supply
	5	+Temp	Temperature sensor connection KTY84-1C130 or PTC
	6	-Temp	
	7	P5	Encoder power supply
	8	Clock	Clock, EnDat interface, SSI clock <sup>1)</sup>
	9	Clock*	Inverse clock, EnDat interface, Inverse SSI clock <sup>1)</sup>
	10	M	Ground for encoder power supply
	11	Enclosure potential	
	12	B	Incremental signal B
	13	B*	Inverse incremental signal B
	14	Data	Data, EnDat interface, SSI data <sup>1)</sup>
	15	A	Incremental signal A
	16	A*	Inverse incremental signal A
	17	Data*	Inverse data EnDat interface, Inverse SSI data <sup>1)</sup>
Blanking plate for encoder system interface: Pöppelmann GmbH & Co. KG, Lohne, Article number: GPN 300 F211 connector kits, 17-pin, Article number: 6FX2003-0SA17			

**NOTICE**

**Damage due to an incorrectly connected KTY temperature sensor**

If the KTY temperature sensor was not connected with the correct polarity, motor overheating may not be detected.

- Connect the KTY temperature sensor with the correct polarity.



**! WARNING**

**Danger to life due to electric shock in the event of voltage flashovers at the temperature sensor**

Voltage flashovers in the signal electronics can occur in motors without safe electrical separation of the temperature sensors.

- Use temperature sensors that comply with the specifications relating to protective separation.
- If safe electrical separation cannot be guaranteed (for linear motors or third-party motors, for example), use a Sensor Module External (SME120 or SME125) or Terminal Module TM120.

**10.4.3 Dimension drawing**

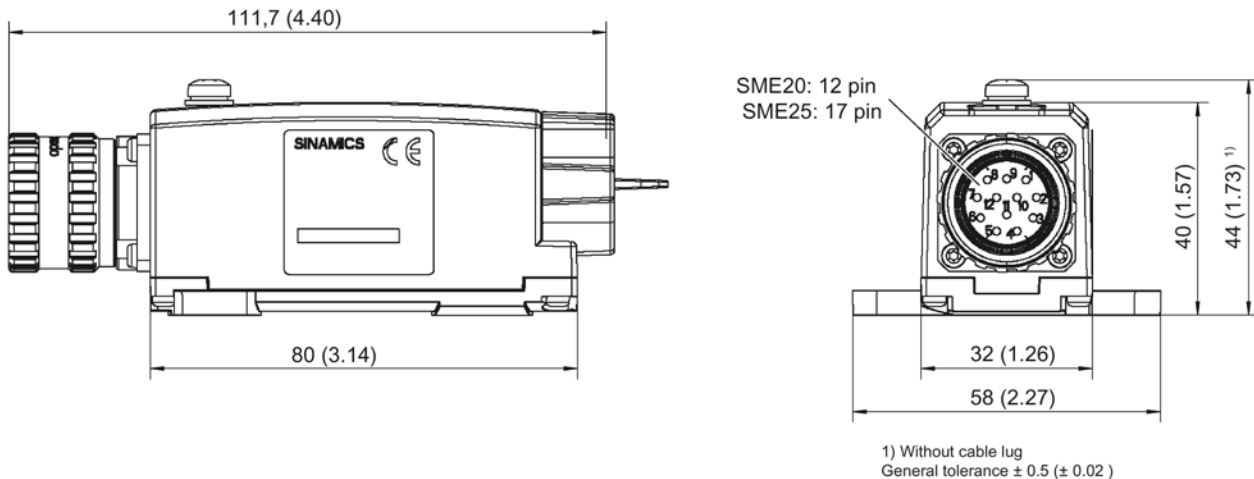
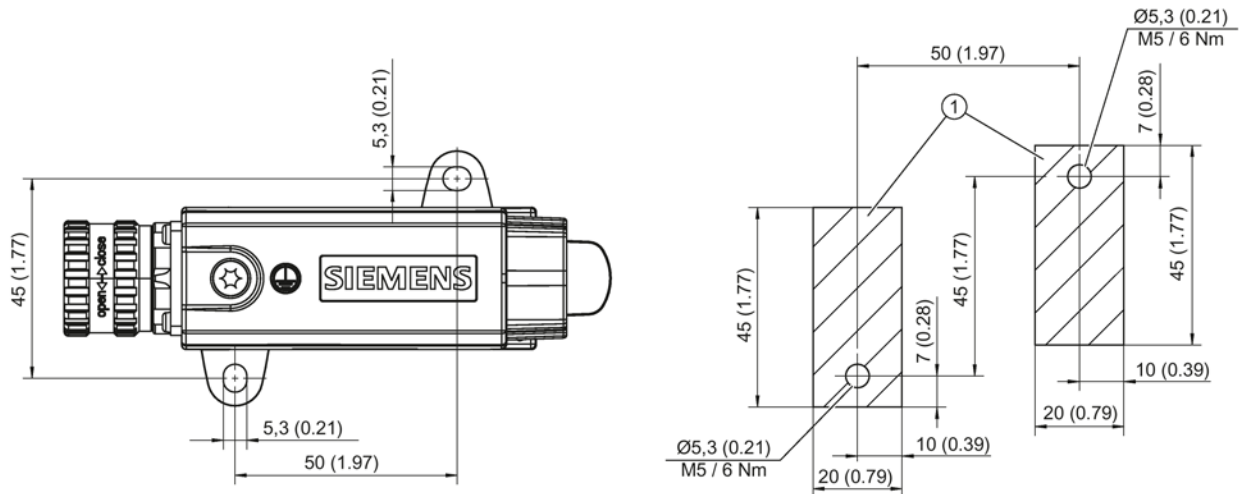

Figure 10-20 Dimension drawing of the Sensor Module External SME25, all data in mm and (inches)  
Article number 6SL3055-0AA00-5HA3

## 10.4.4 Installation



① Contact surface

Figure 10-21 Drilling pattern for installing the SME20/SME25

### Installation

1. Place the drilling pattern on the mounting surface. Make sure that the contact surface is bare, unpainted metal.
2. Drill two holes with  $\varnothing 5.3$  or M5 threaded holes according to the drilling pattern.
3. Fix the Sensor Module to the mounting surface. The tightening torque is 6 Nm.

## 10.4.5 Technical data

Table 10- 20 Technical data

6SL3055-0AA00-5HA3	Unit	Value
Electronics power supply		
Voltage	V <sub>DC</sub>	24 (20.4 ... 28.8)
Current (without encoder system)	A <sub>DC</sub>	≤ 0.15
Current (with encoder system)	A <sub>DC</sub>	≤ 0.25
Power loss	W	≤ 4
Encoder system power supply		
Voltage	V <sub>DC</sub>	5
Current	A <sub>DC</sub>	0.35
Encoder frequency that can be evaluated (f <sub>encoder</sub> )	kHz	≤ 500
SSI/EnDat 2.1 baud rate	kHz	100
PE/ground connection		At the housing with M4/1.8 Nm screw
Weight	kg	0.31
Degree of protection		IP67

The maximum cable length at the encoder system interface depends on the current consumption of the encoder system and the cross-section of the supply cores in the cable. However, the maximum length is 10 m.

For encoder systems that operate in a supply voltage range from 4.75 V to 5.25 V, the following diagram is obtained. The sample parameters shown are 0.28 mm<sup>2</sup> cross-section (0.14 mm<sup>2</sup> supply cores plus 0.14 mm<sup>2</sup> remote sense conductors) and 0.64 mm<sup>2</sup> (0.5 mm<sup>2</sup> supply conductors plus 0.14 mm<sup>2</sup> remote sense conductors).

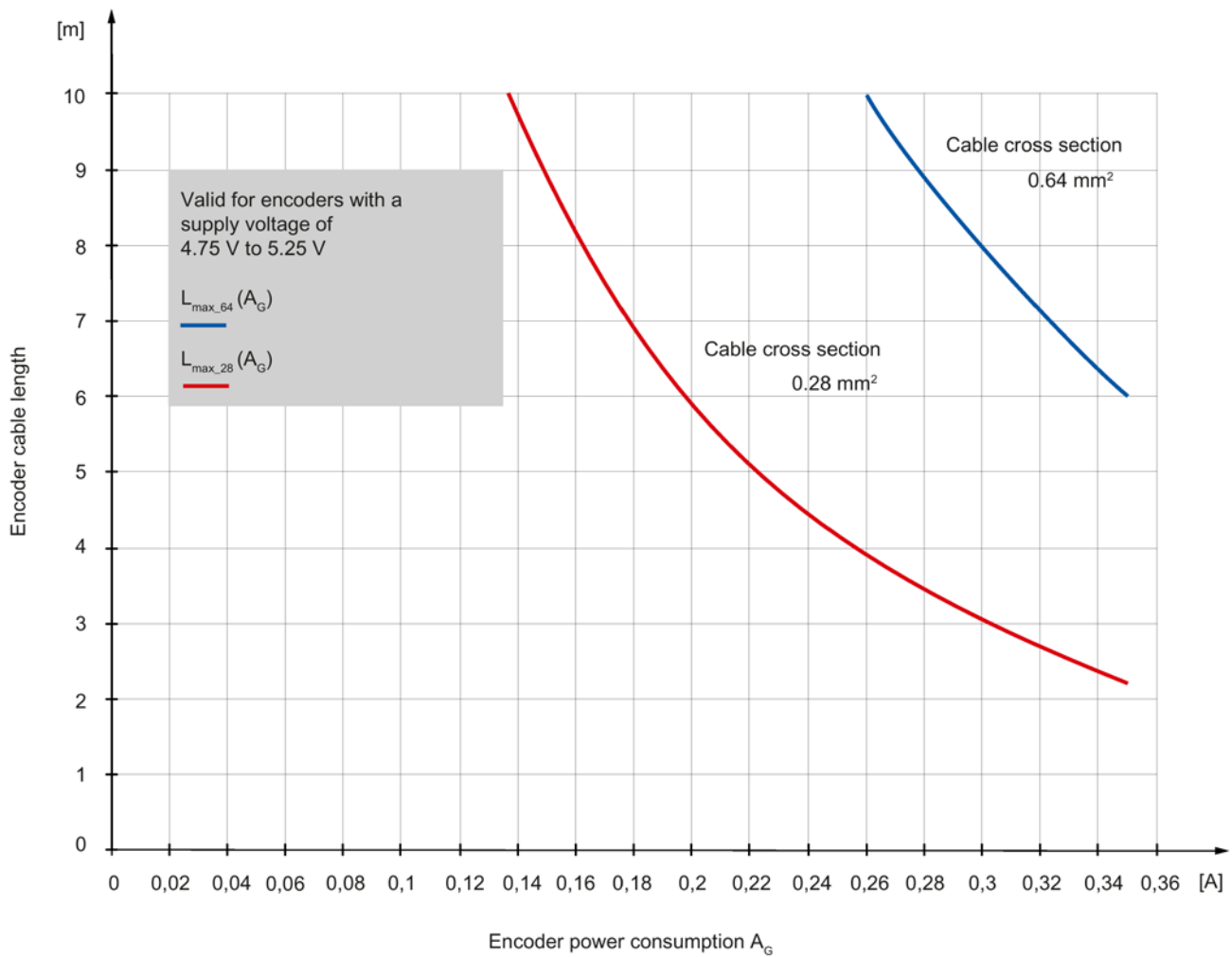

Figure 10-22 Max. cable length as a function of the current drawn by the encoder system

In addition to the encoder systems for a supply voltage range of 4.75 V to 5.25 V in the figure above, encoder systems are also available for an extended range down to 3.6 V. These can be generally operated using encoder system cables up to 10 m long provided that the total cross-section of the supply core plus Remote Sense cores does not fall below 0.14 mm<sup>2</sup>.



## Accessories

### 11.1 DRIVE-CLiQ cabinet bushing

#### 11.1.1 Description

A DRIVE-CLiQ cabinet bushing is used to connect the DRIVE-CLiQ cables between the inside and outside of the control cabinet. It is used in a control cabinet panel. The data lines and the voltage supply contacts of the DRIVE-CLiQ are also routed through the bushing. The DRIVE-CLiQ cabinet bushing for DRIVE-CLiQ cables is available with DRIVE-CLiQ connector and M12 connector/socket.

##### **DRIVE-CLiQ cabinet bushing for DRIVE-CLiQ connectors**

The cabinet bushing has degree of protection IP54 according to IEC 60529 from the outside towards the inside. Inside the control cabinet, a connection is established according to degree of protection IP20 or IPXXB acc. to IEC 60529. So that the complete outside of the cabinet bushing, including the DRIVE-CLiQ interface, has degree of protection IP54, a DRIVE-CLiQ cable must be used, which as a minimum must also have degree of protection IP54.

##### **DRIVE-CLiQ cabinet bushing for M12 connector/socket**

The cabinet bushing has degree of protection IP67 according to IEC 60529 from the outside towards the inside. Inside the cabinet a connection according to degree of protection IP67 in compliance with IEC 60529 is realized.

11.1 DRIVE-CLiQ cabinet bushing

11.1.2 Interface description

11.1.2.1 Overview

DRIVE-CLiQ cabinet bushing for DRIVE-CLiQ cables with DRIVE-CLiQ connectors

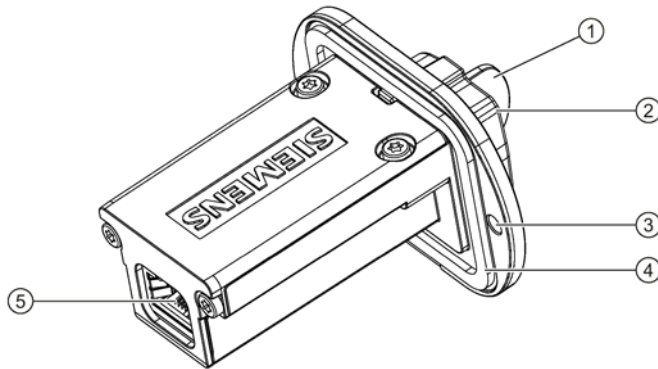

- ① Protective cap, Yamaichi, Article No.: Y-ConAS-24-S
- ② DRIVE-CLiQ interface on the outside (to connect DRIVE-CLiQ signal cables MOTION-CONNECT with IP67 degree of protection)
- ③ Mounting holes
- ④ Flange-type seal to ensure degree of protection IP54 on the outside of the cabinet
- ⑤ DRIVE-CLiQ interface on the inside (to connect DRIVE-CLiQ signal cables MOTION-CONNECT with IP20 degree of protection)

Figure 11-1 Interface overview, DRIVE-CLiQ cabinet bushing

DRIVE-CLiQ cabinet bushing for DRIVE-CLiQ cables with M12 plug/socket

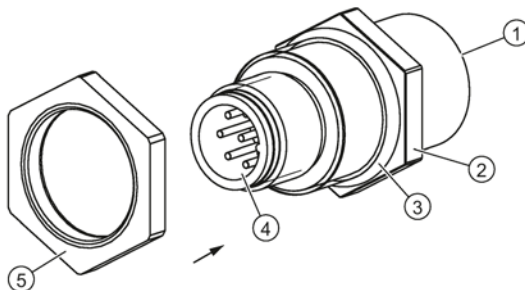

- ① DRIVE-CLiQ interface with M12 socket (8-pin)
- ② Flange, SW18
- ③ Seal
- ④ DRIVE-CLiQ interface with M12 plug (8-pin)
- ⑤ O ring, SW20, tightening torque: 3-4 Nm

Figure 11-2 Interface overview, DRIVE-CLiQ cabinet bushing M12



11.1.3 Dimension drawings

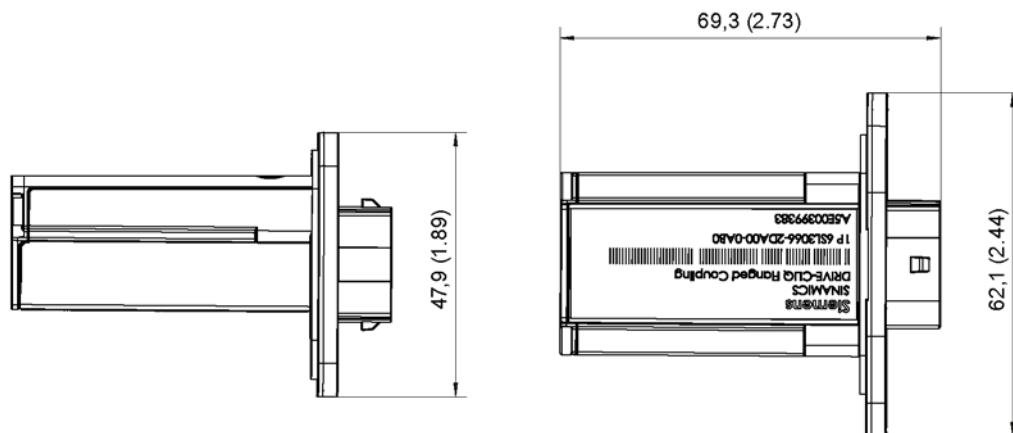

Figure 11-3 Dimension drawing of the DRIVE-CLiQ cabinet gland, all dimensions in mm and (inches)

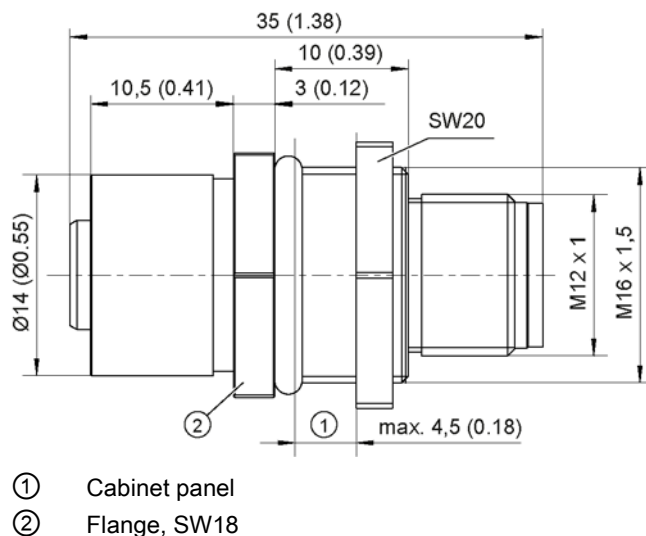

Figure 11-4 Dimension drawing of the DRIVE-CLiQ cabinet bushing M12, all dimensions in mm and (inches)

### 11.1.4 DRIVE-CLiQ cabinet bushing for cables with DRIVE-CLiQ connectors

In order to install the DRIVE-CLiQ cabinet gland, you must make a cutout in the control cabinet panel as shown in the diagram below.

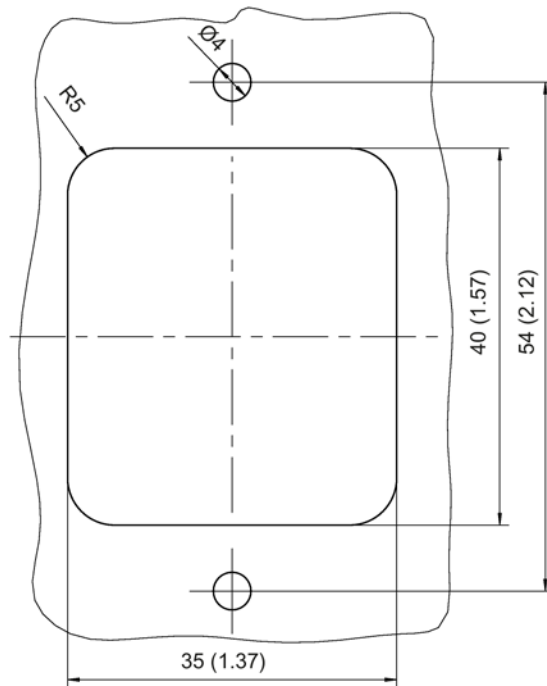
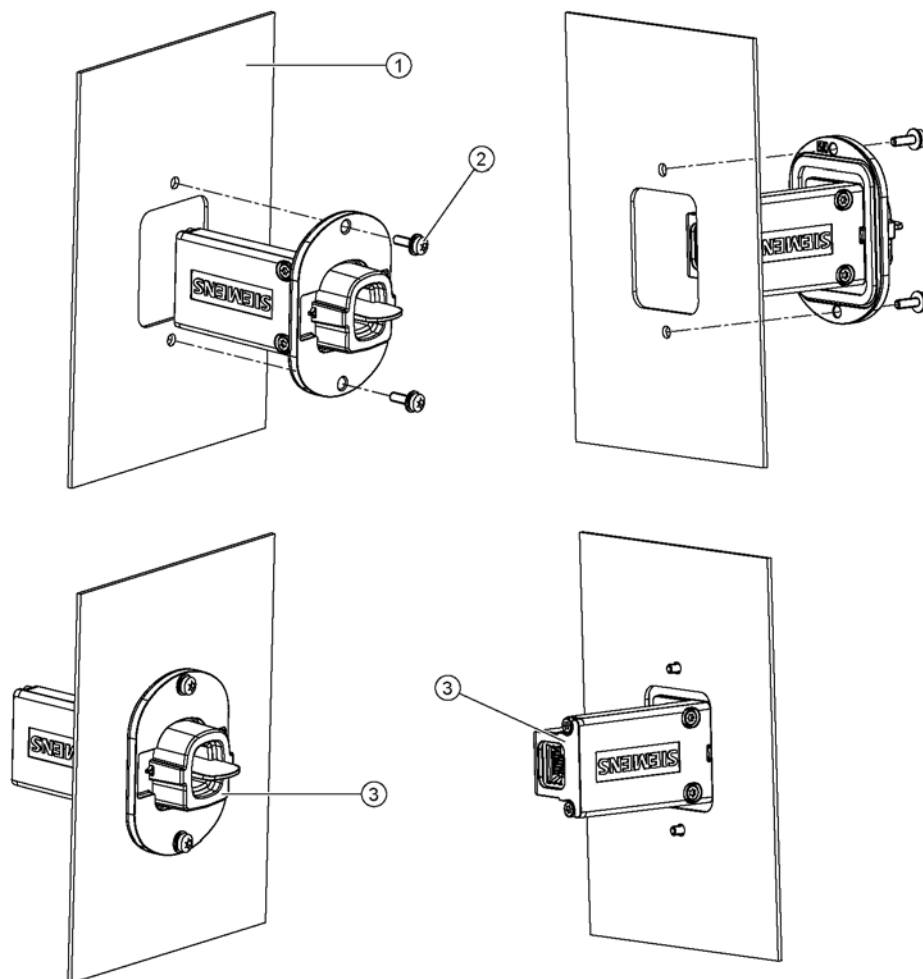

Figure 11-5 Cutout in the control cabinet, all dimensions in mm and (inches)

## Installation

1. Insert the DRIVE CLiQ cabinet bushing from the outside of the control cabinet through the cutout in the control cabinet.
2. Attach the DRIVE-CLiQ cabinet bushing to the outer control cabinet panel using 2 M3 screws and 2 nuts. In order to ensure good electromagnetic compatibility, a good electrical connection must be established between the DRIVE-CLiQ cabinet gland and the cabinet panel over a large surface area.



- ① Control cabinet panel
- ② M3 screw, tightening torque 0.8 Nm
- ③ DRIVE-CLiQ cabinet bushing

Figure 11-6 Installing the DRIVE-CLiQ cabinet bushing for cables with DRIVE-CLiQ connectors

### 11.1.5 Technical data

Table 11- 1 Technical data of DRIVE-CLiQ cabinet bushings

	Unit	6SL3066-2DA00-0AA0 DRIVE-CLiQ	6FX2003-0DT67 M12
Weight	kg	0.165	0.035
Degree of protection to IEC 60529		IP54 outside the control cabinet IP20 or IPXXB inside the control cabinet	IP67

## 11.2 DRIVE-CLiQ coupling

### 11.2.1 Description

The DRIVE-CLiQ coupling is used to connect two DRIVE-CLiQ cables in accordance with degree of protection IP67 acc. to EN 60529.

In addition to the data lines, the power supply contacts of DRIVE-CLiQ are also routed via the coupling.

Information on the permissible cable length can be found in Section "DRIVE-CLiQ signal cables (Page 301)".

### 11.2.2 Safety information

#### NOTICE

##### Damage through use of incorrect DRIVE-CLiQ cables

Damage or malfunctions can occur on the devices or system when incorrect or unreleased DRIVE-CLiQ cables are used.

- Only use suitable DRIVE-CLiQ cables that have been released by Siemens for the respective application.

## 11.2.3 Interface description

### 11.2.3.1 Overview

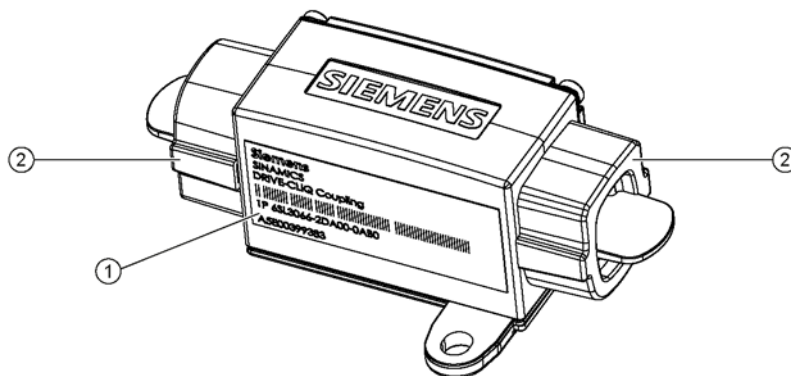

- ① Rating plate
- ② Protective cap, Yamaichi, Article No.: Y-ConAS-24-S

Figure 11-7 Interface overview, DRIVE-CLiQ coupling

## 11.2.4 Dimension drawing

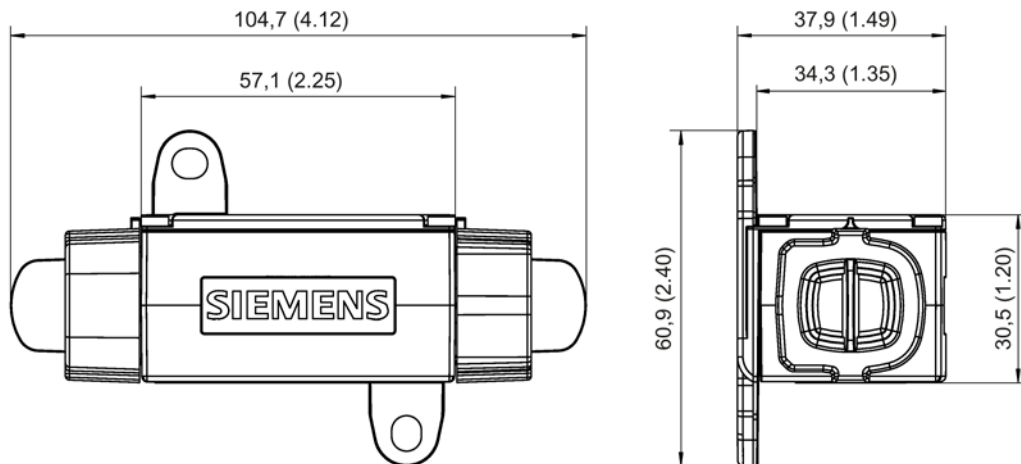
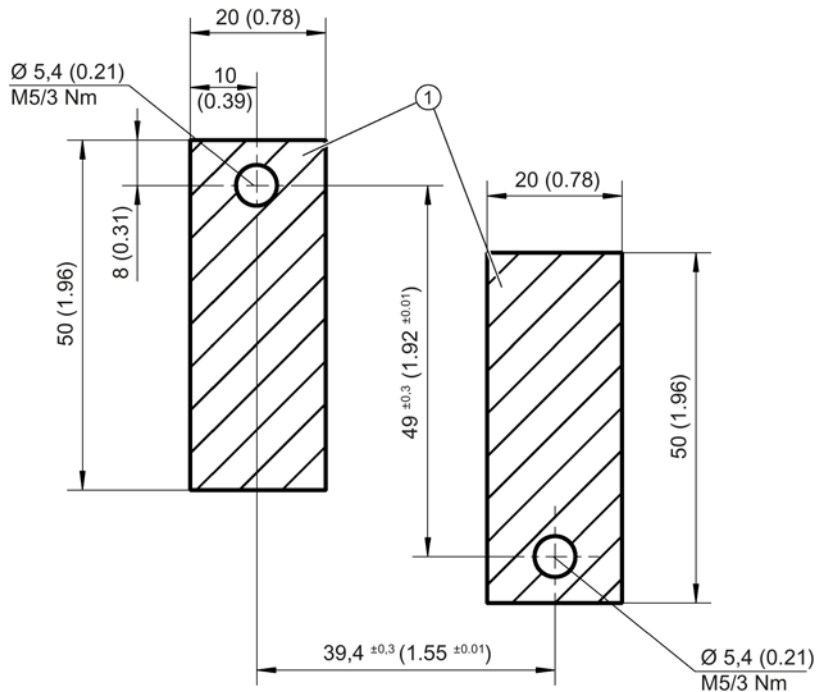

Figure 11-8 Dimension drawing of the DRIVE-CLiQ coupling, all dimensions in mm and (inches)

### 11.2.5 Mounting



① Contact surface

Figure 11-9 Hole drilling pattern for installation

### Installation

1. Attach the DRIVE-CLiQ coupling to the mounting surface as shown in the drilling pattern.
2. Remove the protective caps of the DRIVE-CLiQ coupling.
3. Latch the DRIVE-CLiQ connectors at both sides of the DRIVE-CLiQ coupling.

### 11.2.6 Technical data

Table 11-2 Technical data

DRIVE-CLiQ coupling 6SL3066-2DA00-0AB0	Unit	
Weight	kg	0.272
Degree of protection	IP67 according to IEC 60529	

## Cabinet design and EMC

### 12.1 General information

The S120 Combi Power Modules fulfill the requirements according to degree of protection IP20 in compliance with EN 60529. This provides protection against electric shock for built-in units. As far as UL 50 is concerned, the components are classified and certified as open type.

Protection against mechanical and climatic stressing must be ensured by installing the modules in enclosures, cabinets or electrical rooms that can be closed and locked. Higher-level enclosures must, as a minimum, have degree of protection IP54 according to EN 60529 or be classified as enclosure type 12 in compliance with UL 50.

Prefabricated MOTION-CONNECT cables are recommended.

---

#### Note

##### Functional safety of SINAMICS components

The components must be protected against conductive pollution. This can be achieved e.g. by installing them in a control cabinet with degree of protection IP54 acc. to EN 60529. Provided that conductive pollution can be prevented at the installation site, the degree of protection for the cabinet can be decreased accordingly.

---

##### Low-voltage switchgear and controlgear assemblies

If the S120 Combi is used for the electrical equipment of machines, the applicable requirements of EN 60204-1 must also be adhered to.

##### Safety of machinery

Electrical equipment of machines

All information for device selection in this section applies to

- Operation on TN and TT line supply systems with grounded neutral point and grounded phase conductor
- Operation on IT line supply systems

## 12.2 Safety information

 **WARNING**

**Danger to life if the fundamental safety instructions and remaining risks are not carefully observed**

If the fundamental safety instructions and remaining risks in Chapter 1 (Page 21) are not observed, accidents involving severe injuries or death may occur.

- Adhere to the fundamental safety instructions.
- When assessing the risk, take into account residual risks.

 **WARNING**

**Danger to life due to malfunctions caused by conductive foreign matter**

Foreign matter in the enclosure can cause the devices to malfunction. In turn, this affects the functional safety of machines and can therefore put people in danger or lead to material damage.

- Cover the ventilation slots during installation of the control cabinet to prevent drill swarf, end sleeves, and so on from falling into the enclosure, which could result in short-circuits or damage the insulation.
- Observe the safety regulations with regard to the touch protection. See also EN 60204-1.

**NOTICE**

**Malfunctions and damage due to static discharge**

If static discharge occurs on surfaces or interfaces that cannot be easily accessed, this can cause malfunctions and/or defects.

- Only touch components, modules and devices if you are first grounded by applying one of the following measures:
  - Wearing an ESD wrist strap
  - Wearing ESD shoes or ESD grounding straps in ESD areas with conductive flooring



## 12.3 Directives

The product satisfies the protection targets of the following EU Directives applicable within the European Economic Area (EEA):

Table 12- 1 Directives

Directive	Description
2006/95/EC	Directive of the European Parliament and Council of December 12, 2006, on the approximation of the laws of the member states relating to electrical equipment designed for use within certain voltage limits (Low-Voltage Directive).
2004/108/EC	Directive of the European Parliament and Council of December 15, 2004, which repeals directive 89/336/EEC, on the approximation of laws of the member states relating to electromagnetic compatibility (EMC Directive).

## 12.4 Notes on electromagnetic compatibility (EMC)

Requirements to implement EMC are listed in EN 61000-6-2, EN 61000-6-4, EN 61800-3, EN 60204-1 and in the "EMC installation guideline" Configuration Manual (Article No. 6FC5297-0AD30-0□P□). Conformance with the EMC Directive of the EC can be ensured by following the measures described in the Configuration Manual, EMC installation guideline. When mounting components in cabinets, in order to fulfill the EMC Directive, the following conditions must be additionally observed:

- Connected to TN and TT line supplies with grounded neutral point and grounded phase conductor as well as to IT line supplies.
- Observance of information about cable shielding and equipotential bonding.
- Use of the recommended power and signal cables from Siemens.
- Only cables from Siemens may be used for DRIVE-CLiQ connections.



**NOTICE**

**Damage due to use of incorrect DRIVE-CLiQ couplings or cabinet glands**

Damage or malfunctions can occur on the devices or system when incorrect or unreleased DRIVE-CLiQ couplings or cabinet glands are used.

- Only use suitable DRIVE-CLiQ couplings and cabinet glands that have been released by Siemens for the respective application.

 **DANGER**

**Danger to life due to electric shock in the event of faulty shielding**

Death or serious injury can result when live parts are touched.

- Ensure the correct shielding procedures are used.

 **WARNING**

**Fire hazard due to overheating when permissible cable lengths are exceeded**

Excessively long cable lengths can cause components to overheat with the associated risk of fire and development of smoke.

- The cable lengths (e.g. motor cable, DC link cable) listed in the technical data must not be exceeded.

**Note**

**Radio interference due to high-frequency interference in residential environments**

In a residential environment this product can cause high-frequency interference, which may make interference suppression measures necessary.

This device is not designed for unrestricted operation in the first environment (residential environment) and may not be used in the first environment without suitable interference suppression measures.

- Have qualified personnel carry out the installation and commissioning with suitable interference suppression measures.

## 12.5 Cable shielding and routing

In order to comply with the EMC requirements, certain cables must be routed apart from other cables and from certain components. To full EMC requirements, the following cables must be used with shields:

- Line supply cables from the line filter via the line reactor to the S120 Combi Power Module
- All motor cables (if necessary, including cables for motor holding brake)
- Cables for analog direct voltage/current signals
- Signal cables for sensors
- Cables for temperature sensors

Alternative measures (e.g. routing behind mounting plates, suitable clearances) can also be used provided they have similar results. This excludes measures that relate to the design, installation, and routing of motor power cables and signal cables.

If unshielded cables are used between the line connection point and line filter, make sure that no interfering cables are routed in parallel.

Power and signal cables must always be routed separately. For this purpose, it is practical to arrange the various cables according to cable groups. Cables belonging to a group can be combined in a bundle. The various cable groups must be routed with the necessary clearance between them. A minimum clearance of 20 cm has proven itself in practice. As an alternative, shielding plates with the appropriate contacts at several locations can be used between the cable bundles.

All cables inside the cabinet should be laid as closely as possible to parts connected with cabinet ground, such as a mounting plate or cabinet wall. Ducts made of sheet steel or cables routed between steel sheets (e.g. between the mounting plate and back wall) should provide adequate shielding.

All cables must be kept as short as possible, to minimize the antenna effect.

Signal and power cables may cross each other (if absolutely necessary), but must never be routed closely to one and other in parallel over longer distances.

Signal cables must be routed with a minimum clearance of 20 cm from strong magnetic fields (motors, transformers). Alternatively, shield plates with the appropriate contacts at several locations along their length can be used to provide be appropriate clearance.

**Note:** Cables for the 24 V supply should be treated just like signal cables.

Avoid, where possible, routing non-shielded cables in the immediate vicinity of noise sources, e.g. transformers. Signal cables (shielded and unshielded) must be routed far away from strong external magnetic fields (e.g. transformers, line reactors). In both cases, a distance of  $\geq 300$  mm is usually sufficient.

### Shield support

The cable shields must be connected as close to the conductor terminal connections as possible to ensure a low-impedance connection with cabinet ground. For power cables from Siemens in which the shield is connected to the connector shell (see relevant catalog), this is a sufficiently good shield support.

For components that do not have any special shield connection or where the shield connection is not sufficient, the cable shields can be connected to the metal mounting plate using hose clamps and toothed rails. The cable length between the shield contact point and the terminals for cable cores must be kept as short as possible.

### Routing 24 V cables

When routing 24 V cables, the following must also be observed:

- A maximum of 1 conductor pair may be bundled together.
- 24 V conductors must be routed separately from other cables and conductors that could carry the operating current.
- 24 V cables must never be routed parallel to power cables.
- 24 V cables as well as power cables should be routed to the components so that they never cover ventilation slots.

### Conditions of use for 24 V cables

- Ambient temperature 55 °C
- Conductor temperature limit  $\leq 70^{\circ}$  C for operation with the rated load current<sup>1)</sup>
- Cable length max.:
  - 10 m for the 24 V supply cables
  - 30 m for signal cables without a supplementary RC circuit

<sup>1)</sup> Conductor temperature limit 60 °C for UL applications

## **12.6 24 V DC supply**

### **12.6.1 General information**

The 24 V DC voltage is required to supply the

1. electronics of the S120 Combi and the expansion axes (Motor Modules) via the integrated 24 V busbar
2. Electronics of the SINUMERIK 828D PPU, the Sensor Modules, the Terminal Module, the Braking Module, the DMx as well as the process voltage of its digital inputs
3. Load voltage of the digital outputs
4. Motor holding brake

Other loads can be connected to these power supply units if they are separately protected from overcurrent.

---

**Note**

The electronic power supply has to be supplied by the user as described in the System data (Page 32) section of this documentation.

When connecting to a "DC power supply" in the sense of EN 60204-1:1997, Chapter 4.3.3, functional faults can occur due to the voltage interruptions that are permitted there.

---



 <b>DANGER</b>
---

<b>Danger to life through electric shock due to a terminal voltage that has not been adjusted</b>
---

Death or serious injury can result when live parts are touched.
---

- |  |
|--|
| <ul style="list-style-type: none"> <li>• Only connect protective extra-low voltages to all connections and terminals between 0 and 48 V DC.</li> </ul> |
|--|

<b>NOTICE</b>
---------------

<b>Damage when other loads are connected</b>
--

If other loads are connected to the power supply, overvoltage can damage all components
---

- |  |
|--|
| <ul style="list-style-type: none"> <li>• Fit the connected inductance devices (contactors, relays) with suitable overvoltage protection circuits.</li> </ul> |
|--|
- 

**Note**
**Malfunction because 24 V supply voltage is too low**

If the 24 V supply voltage falls short of the specified minimum value on a device in the assembly, a malfunction can occur.

- Select an input voltage that is high enough for there to be sufficient voltage on the last device. Do not exceed the maximum value for the supply voltage. If required, supply the voltage to the assembly at various locations.
- 

**Note**

A regulated DC power supply is required to operate motors with a built-in holding brake. The voltage is supplied via the internal 24 V busbars. The voltage tolerances of the motor holding brakes (24 V  $\pm$ 10%) and the voltage drops of the connecting cables must be taken into account.

The DC power supply should be set to 26 V. The Control Supply Module supplies 26 V. This ensures that the supply voltage for the brake remains within the permissible range when the following conditions are fulfilled:

- Use of Siemens three-phase motors
- Use of Siemens MOTION-CONNECT power cables
- Motor cable lengths, max. 50 m<sup>1)</sup>

<sup>1)</sup> 70 m for an 18 A supplementary axis

---

## 12.6.2 24 V power supply and connection of components

The S120 Combi with the expansion axes (Motor Modules) and DC link components are connected to the 24 V DC via the integrated 24 V busbars. The current carrying capacity of these busbars is 20 A.

The power can be supplied in two ways:

1. When using an external 24 V power supply, e.g. SITOP, the 24 V connector must be used. The external power supply should be located very close to the load (max. cable length 10 m). Miniature circuit breakers with tripping characteristic D are recommended as overcurrent. The ground potential M must be connected to the protective conductor system (DVC A).

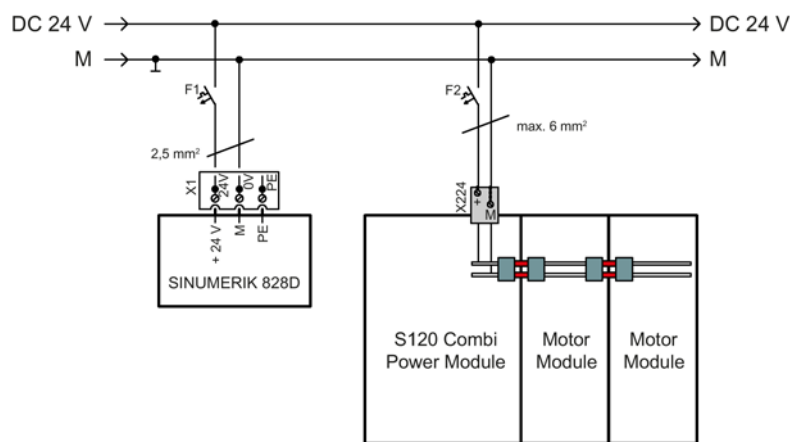

Figure 12-1 Example of an external 24 V power supply

2. When a Control Supply Module is used, the 24 V supply can be directly established through the busbars. The electronic current limiting function integrated in the Control Supply Module protects the busbar system when a fault occurs. Additional loads can be connected via the 24 V connector.

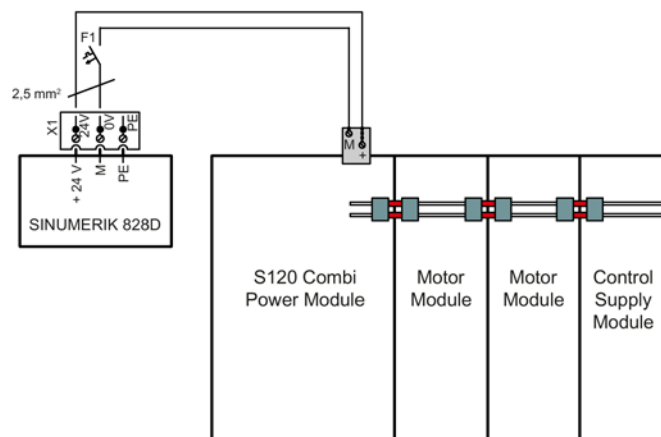

Figure 12-2 Example of a 24 V supply with Control Supply Module

---

**Note**

When using cables with a cross-section of 2.5 mm<sup>2</sup>, no additional protection is required on the 24 V side if a type XLPE or EPR cable, or a cable with a similar quality and with a thermal stability of up to 90 °C is used.

---

**Using the 24 V connector**

- A 24 V connector must be plugged onto the 24 V busbar between each S120 Combi, expansion axis and DC-link component
- Insertion and withdrawal is only permissible in the no-voltage state
- Only 5 withdrawal and insertion cycles are permissible



### 12.6.3 Overcurrent protection in the 24 V solid-state circuit

The cables on the primary and secondary sides of the 24 V power supply unit must be protected against overcurrent.

The protection on the primary side depends on the instructions of the equipment manufacturer.

The protection on the secondary side depends on the actual conditions. Please note the following:

- Loading from loads, possibly the demand factor against the operation of the machine
- Current carrying capacity of the conductors used and cables in normal and short-circuit conditions
- Ambient temperature
- Cable bundling (laying cables in a common duct)
- Cable routing type

Overcurrent protective devices can be used in compliance with local installation regulations.

Circuit breakers as listed in the Siemens "NSK" catalog are recommended as overcurrent protection devices on the primary side.

Miniature circuit breakers or SITOP select (Article number 6EP1961-2BA00) are recommended as overcurrent protection devices on the secondary side. The MCBs can be selected according to Siemens catalog "BETA Modular Installation Devices - ET B1".

When selecting the miniature circuit breaker, local installation regulations must be carefully complied with.

Table 12- 2 MCBs by core cross-section and temperature

Core cross-section	Max. value up to 40 °C	Max. value up to 55 °C
1.5 mm <sup>2</sup>	10 A	6 A
2.5 mm <sup>2</sup>	16 A	10 A
4 mm <sup>2</sup>	25 A	16 A
6 mm <sup>2</sup>	32 A	20 A
24 V busbar	20 A	20 A

The trip characteristic of the MCBs must be selected to match the loads to be protected and the max. current provided by the power supply unit in the event of a short-circuit.

## 12.6.4 Typical 24 V current consumption of the components

A separate 24 V power supply must be used for the SINAMICS S120 drive group.

The following table can be used to calculate the 24 V DC power supply. The values for typical current consumption are used as a basis for configuration.

Table 12- 3 Overview of 24 V DC current consumption

Component	Typical current consumption [A <sub>DC</sub> ]
<b>Controller</b>	
SINUMERIK 828D - PPU without load	1,2
SINUMERIK 828D - PPU with full load (USB, handwheel, ...)	2,5
SINUMERIK NCU 710.3 PN without load	0,9
SINUMERIK NCU 710.3 PN with full load	11,7
<b>Sensor Modules</b>	
SMC20 without/with encoder system	0,20 / 0,355
SMC30 without/with encoder system	0,20 / 0,55
SME20 without/with encoder system	0,15 / 0,25
SME25 without/with encoder system	0,15 / 0,25
<b>Terminal Modules</b>	
TM54F (without digital outputs, without DRIVE-CLiQ)	0,2
Per digital output/DRIVE-CLiQ	0,5
<b>Additional system components</b>	
DMC20 (without DRIVE-CLiQ) per DRIVE-CLiQ	0,15 0,5
DME20 (without DRIVE-CLiQ) per DRIVE-CLiQ	0,15 0,5
<b>S120 Combi 3 axes Power Module</b>	
16 kW / 18 A / 5 A / 5 A	1,5
16 kW / 24 A / 9 A / 9 A	1,5
20 kW / 30 A / 9 A / 9 A	1,5
<b>S120 Combi 4 axes Power Module</b>	
10 kW / 24 A / 12 A / 12 A / 12 A	1,6
16 kW / 18 A / 9 A / 5 A / 5 A	1,6
16 kW / 24 A / 9 A / 9 A / 9 A	1,6
20 kW / 30 A / 12 A / 9 A / 9 A	1,6
<b>DRIVE-CLiQ and brake</b>	
DRIVE-CLiQ (e.g. motors with DRIVE-CLiQ interface)	0,19
Brake (e.g. motor holding brake)	Max. 1
<b>Single Motor Modules Booksize Compact</b>	
3 A (+1 x DRIVE-CLiQ; +1 x brake)	0,75
5 A (+1 x DRIVE-CLiQ; +1 x brake)	0,75

Component	Typical current consumption [A <sub>DC</sub> ]
9 A (+1 x DRIVE-CLiQ; +1 x brake)	0,75
18 A (+1 x DRIVE-CLiQ; +1 x brake)	0,75
<b>Double Motor Modules Booksize Compact</b>	
2 x 1.7 A (+2 x DRIVE-CLiQ; +2 x brake)	1
2 x 3 A (+2 x DRIVE-CLiQ; +2 x brake)	1
2 x 5 A (+2 x DRIVE-CLiQ; +2 x brake)	1
<b>External fan unit</b>	0,8
<b>Braking Module</b>	0,5
<b>Motor encoder</b>	0,25

### Example: calculating 24 V DC current requirements

Table 12- 4 Example of 24 V DC current requirements

Component	Number	Current consumption [A]	Total current consumption [A]
SINUMERIK 828D	1	2,5	2,5
S120 Combi 4 axes Power Module with external fan unit	1	2,4	2,4
Motor Module 9 A	1	0,75	0,75
Motor Module 18 A	1	0,75	0,75
Motor encoder	6	0,25	1,50
Brake	1	1	1
<b>Total:</b>			<b>8,9</b>

## 12.6.5 Selecting power supply units

You are advised to use the devices in the following table. These devices meet the applicable requirements of EN 60204-1.

Table 12- 5 Recommended SITOP Power

Rated output current [A]	Phases	Rated input voltage [V] Working voltage range [V]	Short-circuit current [A]	Article number
5	1 / 2	AC 120 ... 230 / 230 ... 500 85 ... 264 / 176 ... 550	Approx. 5.5 (power up) Typ. 15 for 25 ms (operation)	6EP1333-3BA00-8AC0
10	1 / 2	AC 120 ... 230 / 230 ... 500 85 ... 264 / 176 ... 550	Approx. 12 (power up) Typ. 30 for 25 ms (operation)	6EP1334-3BA00-8AB0
20	1 / 2	AC 120 / 230 85 ... 132 / 176 ... 264	Approx. 23 (power up) Typ. 60 for 25 ms (operation)	6EP1336-3BA00-8AA0
	3	3 AC 230 / 400 ... 288 / 500 320 ... 550		6EP1436-3BA00-8AA0
40	1 / 2	AC 120 / 230 85 ... 132 / 176 ... 264	Approx. 46 (power up) Typ. 120 for 25 ms (operation)	6EP1337-3BA00-8AA0
	3	3-ph. 230/400 to 288/500 320 - 550 AC		6EP1437-3BA00-8AA0

### Note

When using an external 24 V power supply with a continuous current > 20 A, an overcurrent protection device must be used for the S120 Combi Power Module, the cables and the busbars. A circuit breaker is recommended as overcurrent protection device.

The tripping characteristic of the circuit breaker depends on the following:

- the loads to be protected
- The maximum current provided by the power supply unit in the case of a short-circuit.

Table 12- 6 Recommendation for Control Supply Module

Rated output current [A]	Phases	Input voltage range [V]	Short-circuit current [A]	Article number
20	3	AC 380 - 10 % (- 15 % < 1 min) ... AC 480 + 10 % DC 300 ... 800	< 24	6SL3100-1DE22-0AA1

See also catalog NC61.

## 12.7 Connection system

### 12.7.1 DRIVE-CLiQ signal cables

---

**Note**

Only MOTION-CONNECT 500 and MOTION-CONNECT 800PLUS DRIVE-CLiQ cables are permitted for the connection. The maximum cable length for MOTION-CONNECT 500 cables is 100 m, for MOTION-CONNECT 800PLUS cables 75 m.

---

The maximum permissible cable length for the use of DRIVE-CLiQ couplings is calculated as follows:

$$\Sigma MC500 + 4/3 \times \Sigma MC800PLUS + n_c \times 5 \text{ m} \leq 100 \text{ m}$$

$\Sigma MC500$ : Total length of all MC500 cable segments (fixed routing)

$\Sigma MC800PLUS$ : Total length of all MC800PLUS cable segments (tow chain)

$n_c$ : Number of DRIVE-CLiQ couplings (max. 0 ... 3)

Table 12- 7 Comparison between MOTION-CONNECT 500 and MOTION-CONNECT 800PLUS DRIVE-CLiQ cables

DRIVE-CLiQ signal cable	MOTION-CONNECT 500	MOTION-CONNECT 800PLUS
<b>Approvals</b>		
VDE cURus or UR/CSA UR-CSA File No. <sup>1)</sup> in conformance with RoHS	Yes UL STYLE 2502/CSA-N.210.2-M90 Yes Yes	Yes UL STYLE 2502/CSA-N.210.2-M90 Yes Yes
<b>Rated voltage <math>V_0/V</math> in accordance with EN 50395</b>	30 V	30 V
<b>Test voltage, rms</b>	500 V	500 V
<b>Operating temperature at the surface</b>		
Permanently installed Moveable	-20 ... +80 °C 0 ... 60 °C	-20 ... +80 °C -20 ... +60 °C
<b>Strain, max.</b>		
Permanently installed Moveable	80 N/mm <sup>2</sup> 30 N/mm <sup>2</sup>	50 N/mm <sup>2</sup> 20 N/mm <sup>2</sup>
<b>Smallest bending radius</b>		
Permanently installed Moveable	35 mm 125 mm	35 mm 75 mm
<b>Torsional stress</b>	30°/m absolute	30°/m absolute
<b>Bending operations</b>	100000	10 million
<b>Max. traversing speed</b>	30 m/min	300 m/min
<b>Max. acceleration</b>	2 m/s <sup>2</sup>	Up to 50 m/s <sup>2</sup> (3 m)
<b>insulation material</b>	CFC/silicone-free	CFC/halogen-free/silicon-free
<b>Oil resistance</b>	EN 60811-2-1 (mineral oil only)	EN 60811-2-1
<b>Protective jacket</b>	PVC	PUR, HD22.10 S2 (VDE 0282, Part 10)
<b>Flame retardant</b>	EN 60332-1-1 to 1-3	EN 60332-1-1 to 1-3

<sup>1)</sup> The file number is printed on the cable jacket.

## 12.7.2 Power cables for motors

### 12.7.2.1 Approved power cables

#### Note

Only MOTION-CONNECT 500 and MOTION-CONNECT 800 power cables are permissible for the S120 Combi.

Table 12- 8 Approved power cables for motors connected to the S120 Combi - prefabricated

Motor	Article number 6FXx002-	Description	D <sub>max</sub>	
			6FX5	6FX8
1PH8 with terminal box	5CE02	Power cable 1PH808 4 x 2.5	10.0	12.1
1PH8 with terminal box	5CE04	Power cable 1PH810 4 x 4	11.4	13.2
1PH8 with terminal box	5CE06	Power cable 1PH813 4 x 6	13.6	16.0
1FT7/1FK7 with quick release	5CF10	Power cable 4 x 1.5 GR.1 SC	8.4	10.4
	5DF10	Power cable 4 x 1.5 + 2 x 1.5 GR.1 SC	10.8	12.9
1PH8 with connector with fast release	5DF11	Power cable 4 x 2.5 GR.1.5 SC	10.0	12.1
1PH8 with connector with fast release	5CF12	Power cable 4 x 4 GR.1.5 SC	11.4	13.2
1PH8 with connector without fast release	5CF13	Power cable 4 x 10 GR.3	20	19.4

x: 5 = MC500, 8 = MC800

 <b>WARNING</b>
<p><b>Danger to life due to missing emergency motor shutdown option</b></p> <p>If the motor holding brake is not connected or is incorrectly connected, serious physical injuries can occur.</p> <ul style="list-style-type: none"> <li>• Only connect motors with a safe electrically isolated holding brake. The brake cores must also be safely electrically isolated.</li> <li>• If the motor power cable is connected to intermediate terminals, the power cables and brake cables must be routed separately (<math>\geq 300</math> mm) from each other.</li> </ul>

#### Note

If the connecting cables for a 24 V motor holding brake are included in the power cable, then only the specified cables must be used. These cables must have a separate shield for the 24 V and must be suitable for safe electrical separation.

The cable shield of the motor holding brake conductors must be connected at both ends.

#### Note

In order that the specified EMC limit values (EN 61800-3) are maintained, only shielded type MC500 and MC800 power cables must be used. The permissible cable length is 25 m for rated output currents  $I_n$  from 5 A to 30 A.

The total cable length for the complete drive line-up is 175 m.

### Comparison of MOTION-CONNECT power cables

MOTION-CONNECT 500 power cables are mainly suitable for permanent routing. The MOTION-CONNECT 800PLUS power cables fulfill all high mechanical requirements for the use in tow chains. They are resistant to cutting oils.

Table 12- 9 Comparison of the MOTION-CONNECT 500 and MOTION-CONNECT 800PLUS power cables

Power cable	MOTION-CONNECT 500	MOTION-CONNECT 800PLUS
<b>Approvals</b>		
VDE <sup>1)</sup> cURus or UR/CSA UR-CSA File No. <sup>2)</sup> in conformance with RoHS	Yes UL758-CSA-C22.2-N.210.2-M90 Yes Yes	Yes UL758-CSA-C22.2-N.210.2-M90 Yes Yes
<b>Rated voltage <math>V_0/V</math> in accordance with EN 50395</b>		
Supply conductors Signal conductors	600 V / 1000 V 24 V (EN) 1000 V (UL/CSA)	600 V / 1000 V 24 V (EN) 1000 V (UL/CSA)
<b>Test voltage, rms</b>		
Supply conductors Signal conductors	4 kV 2 kV	4 kV 2 kV
<b>Operating temperature at the surface</b>		
Permanently installed Moveable	-20 ... +80 °C 0 ... 60 °C	-20 ... +80 °C -20 ... +60 °C
<b>Strain, max.</b>		
Permanently installed Moveable	50 N/mm <sup>2</sup> 20 N/mm <sup>2</sup>	50 N/mm <sup>2</sup> 20 N/mm <sup>2</sup>
<b>Smallest bending radius</b>		
Permanently installed Moveable	5 x D <sub>max</sub> Approx. 18 x D <sub>max</sub>	4 x D <sub>max</sub> Approx. 8 x D <sub>max</sub>
<b>Torsional stress</b>	30°/m absolute	30°/m absolute
<b>Bending operations</b>	100000	10 million
<b>Max. traversing speed</b>	30 m/min	Up to 300 m/min
<b>Max. acceleration</b>	2 m/s <sup>2</sup>	50 m/s <sup>2</sup> (3 m)
<b>insulation material</b>	CFC/silicone-free	CFC/halogen/silicone-free IEC 60754-1 / DIN VDE 0472-815
<b>Oil resistance</b>	EN 60811-2-1 (mineral oil only)	EN 60811-2-1
<b>Protective jacket</b>	PVC	PUR, HD22.10 S2 (VDE 0282, Part 10)
<b>Flame retardant</b>	EN 60332-1-1 to 1-3	EN 60332-1-1 to 1-3

<sup>1)</sup> The registration number is printed on the cable jacket.

<sup>2)</sup> The file number is printed on the cable jacket.



### 12.7.3 Current-carrying capacity and derating factors for power cables and signal cables

The current-carrying capacity of PVC/PUR-insulated copper cables is specified for routing types B1, B2 and C under continuous operating conditions in the table with reference to an ambient air temperature of 40 °C. For other ambient temperatures, the values must be corrected by the factors listed in the "Derating factors for deviating conditions" table.

Table 12- 10 Current-carrying capacity according to EN 60204-1 for 40 °C ambient temperature

Cross-section mm <sup>2</sup>	Current-carrying capacity, effective; AC 50/60 Hz or DC for routing type		
	B1 A	B2 A	C A
<b>Electronics</b>			
0,20	–	4,3	4,4
0,50	–	7,5	7,5
0,75	–	9	9,5
<b>Power</b>			
0,75	8,6	8,5	9,8
1,00	10,3	10,1	11,7
1,50	13,5	13,1	15,2
2,50	18,3	17,4	21
4	24	23	28
6	31	30	36
10	44	40	50
16	59	54	66

#### Installation types

B1 cables in conduits or installation ducts

B2 multi-core cables in conduits or installation ducts

C cables along walls/panels without conduits and installation ducts

Table 12- 11 Derating factors for deviating conditions

Ambient temperature [°C]	Derating factor according to EN 60204-1 Table D1
30	1,15
35	1,08
40	1,00
45	0,91
50	0,82
55	0,71
60	0,58

**Example for dimensioning a power cable**

**Boundary conditions:**

Module: S120 Combi 4 axes Power Module with 20 kW infeed

Rated input current at 400 V<sub>AC</sub>: 34 A (from the technical data)

Ambient temperature: 45 °C

Installation type: B2

**Calculation/dimensioning:**

With installation type B2 and a rated input current of 34 A<sub>AC</sub>, from the table showing the current-carrying capacity, a cable cross-section of 10 mm<sup>2</sup> is obtained.

With a derating factor of 0.91 for 45°C ambient temperature, the current-carrying capacity of the selected power cable decreases to 36.4 A.

**Result:**

Under the given boundary conditions, a power cable with a cross-section of 10 mm<sup>2</sup> can be used.

**12.7.4 Connectable conductor cross-sections for spring-loaded terminals**

Table 12- 12 Spring-loaded terminals

Type: Spring-loaded terminal			
1	Connectable conductor cross-sections	Flexible	0.08 ... 2.5 mm <sup>2</sup>
	Stripped length	8 ... 9 mm	
	Tool	Screwdriver 0.4 x 2.0 mm	

## 12.7.5 Connectable conductor cross-sections for screw terminals

The type of screw terminal can be taken from the interface description of the particular module.

Table 12- 13 Screw terminals

Type: Screw terminal			
1	Connectable conductor cross-sections	Rigid, flexible With end sleeve, without plastic sleeve With end sleeve, with plastic sleeve	0.08 ... 1.5 mm <sup>2</sup> 0.25 ... 1.5 mm <sup>2</sup> 0.25 ... 0.5 mm <sup>2</sup>
	Stripped length	7 mm	
	Tool	Screwdriver 0.4 x 2.0 mm	
	Tightening torque	0.22 ... 0.25 Nm	
2	Connectable conductor cross-sections	Rigid, flexible With end sleeve, without plastic sleeve With end sleeve, with plastic sleeve	0.14 ... 1.5 mm <sup>2</sup> 0.25 ... 1.5 mm <sup>2</sup> 0.25 ... 0.5 mm <sup>2</sup>
	Stripped length	7 mm	
	Tool	Screwdriver 0.4 x 2.5 mm	
	Tightening torque	0.22 ... 0.25 Nm	
3	Connectable conductor cross-sections	Rigid, flexible With end sleeve, without plastic sleeve With end sleeve, with plastic sleeve AWG / kcmil	0.2 ... 2.5 mm <sup>2</sup> 0.2 ... 2.5 mm <sup>2</sup> 0.2 ... 1.5 mm <sup>2</sup> 22 ... 12
	Stripped length	6 ... 7 mm	
	Tool	Screwdriver 0.5 x 3 mm	
	Tightening torque	0.4 ... 0.5 Nm	
4	Connectable conductor cross-sections	Flexible With end sleeve, without plastic sleeve With end sleeve, with plastic sleeve	0.2 ... 4 mm <sup>2</sup> 0.25 ... 4 mm <sup>2</sup> 0.25 ... 4 mm <sup>2</sup>
	Stripped length	7 mm	
	Tool	Screwdriver 0.6 x 3.5 mm	
	Tightening torque	0.5 ... 0.6 Nm	
5	Connectable conductor cross-sections	Flexible With end sleeve, without plastic sleeve With end sleeve, with plastic sleeve	1 ... 6 mm <sup>2</sup> 1 ... 6 mm <sup>2</sup> 1 ... 6 mm <sup>2</sup>
	Stripped length	10 mm	
	Tool	Screwdriver 1.0 x 4.0 mm	
	Tightening torque	1.5 ... 1.8 Nm	
6	Connectable conductor cross-sections	Flexible With end sleeve, without plastic sleeve With end sleeve, with plastic sleeve	1 ... 10 mm <sup>2</sup> 1 ... 10 mm <sup>2</sup> 1 ... 10 mm <sup>2</sup>
	Stripped length	10 mm	
	Tool	Screwdriver 1.0 x 4.0 mm	
	Tightening torque	1.5 ... 1.8 Nm	

Type: Screw terminal			
7	Connectable conductor cross-sections	Flexible With end sleeve, without plastic sleeve With end sleeve, with plastic sleeve	1.5 ... 16 mm <sup>2</sup> 1.5 ... 16 mm <sup>2</sup> 1.5 ... 16 mm <sup>2</sup>
	Stripped length	11 mm	
	Tool	Screwdriver 1.0 x 4.0 mm	
	Tightening torque	1.5 ... 1.8 Nm	

### 12.7.6 Cable lugs

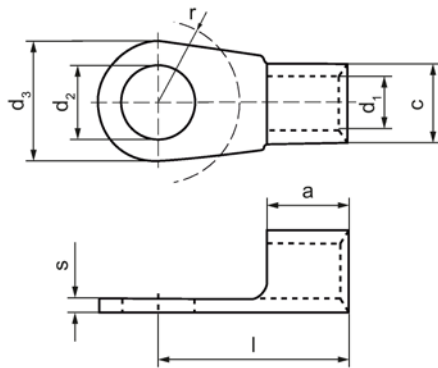

Figure 12-3 Dimension drawing of cable lugs

Table 12- 14 Dimensions of cable lugs

Screw/bolt	Cable cross-section [mm <sup>2</sup> ]	a [mm]	c [mm]	d <sub>1</sub> [mm]	d <sub>2</sub> [mm]	d <sub>3</sub> [mm]	l [mm]	r [mm]	s [mm]
M5	6	6	6	3.6	5.3	10	15	6.5	1

## 12.8 Protective connection and equipotential bonding

### Protective connections

The S120 Combi is designed for use in control cabinets with a protective conductor connection.

The protective conductor connection of the S120 Combi must be connected to the protective conductor connection of the control cabinet as follows:

Table 12- 15 Cross-section for copper protective conductors

Line supply cable in mm <sup>2</sup>	Protective connection in mm <sup>2</sup> copper
Up to 16 mm <sup>2</sup>	The same as the line supply cable
From 16 mm <sup>2</sup> to 35 mm <sup>2</sup>	16 mm <sup>2</sup>
From 35 mm <sup>2</sup>	0.5 * line supply cable

For materials other than copper, the cross-section should be increased so that as a minimum, the same conductivity is attained.

All plant and machine parts must be incorporated in the protective concept.

The protective ground connection of the motors used must be established through the motor cable. For EMC reasons, these protective ground connections should be connected at the S120 Combi.

In order to maintain the EMC limit values, the S120 Combi drive line-up - including the expansion axes and DC link components - must be arranged together on a bare metal mounting plate. The mounting plate serves as an equipotential bonding surface. This means that no additional equipotential bonding is required within the drive line-up. The mounting plate must be connected to the protective conductor connection of the control cabinet through a low impedance.

## Equipotential bonding

A mounting plate serves simultaneously as an equipotential bonding surface. This means that no additional equipotential bonding is required within the drive line-up.

If a common bare metal mounting plate is not available, then an equally good equipotential bonding must be established using cable cross-sections as listed in the table above or as a minimum with the same conductivity.

When mounting components on standard mounting rails, the equipotential bonding data listed in the table apply. If only smaller connection cross-sections are permissible at the components, then the largest possible cross-section should be used, e.g. 6 mm<sup>2</sup> for SMC. These requirements also apply to distributed components located outside the control cabinet.

---

### Note

Non-observance of the above guidelines on equipotential bonding can lead to faults on the fieldbus interfaces or to malfunction of the devices.

---

## 12.9 Note on control cabinet cooling

### 12.9.1 General information

The cabinet can be cooled, among others, by using:

- Filter fans
- Heat exchangers
- Refrigerators
- External air cooling

The decision in favor of one of these methods will depend on the prevailing ambient conditions and the cooling power required.

The air routing inside the control cabinet and the cooling clearances specified here, must be carefully observed. Other components or cables must not be installed/routed in these areas.

#### NOTICE

##### Reduced service life due to non-compliance with the installation guidelines

If you do not observe the guidelines for installing SINAMICS equipment in the cabinet, this can reduce the service life of the equipment and result in premature component failure.

- Always comply with the installation guidelines for SINAMICS devices.

You must take into account the following specifications when installing a SINAMICS drive line-up:

- Ventilation clearance
- Wiring and cabling
- Air guidance, air-conditioner

Table 12- 16 Ventilation clearances above and below the components

Component	Article number	Clearance [mm]
S120 Combi 3 axes Power Module	6SL3111-3VE2-..A0	80
S120 Combi 4 axes Power Module	6SL3111-4VE2-..A0	80
Motor Modules Booksize Compact	6SL3420-..TE..-AA.	80
Line filter	6SL3000-0BE21-6DA1	100
Line reactors	6SL3100-0EE2-..AA0	100
Braking Module	6SL3100-1AE31-0AA.	80
Control Supply Module	6SL3100-1DE22-0AA.	80
SMC20	6SL3055-0AA00-5EA.	50
SMC30	6SL3055-0AA00-5CA.	50
DMC20	6SL3055-0AA00-6AA.	50
Terminal Module TM54F	6SL3055-0AA00-3BA.	50

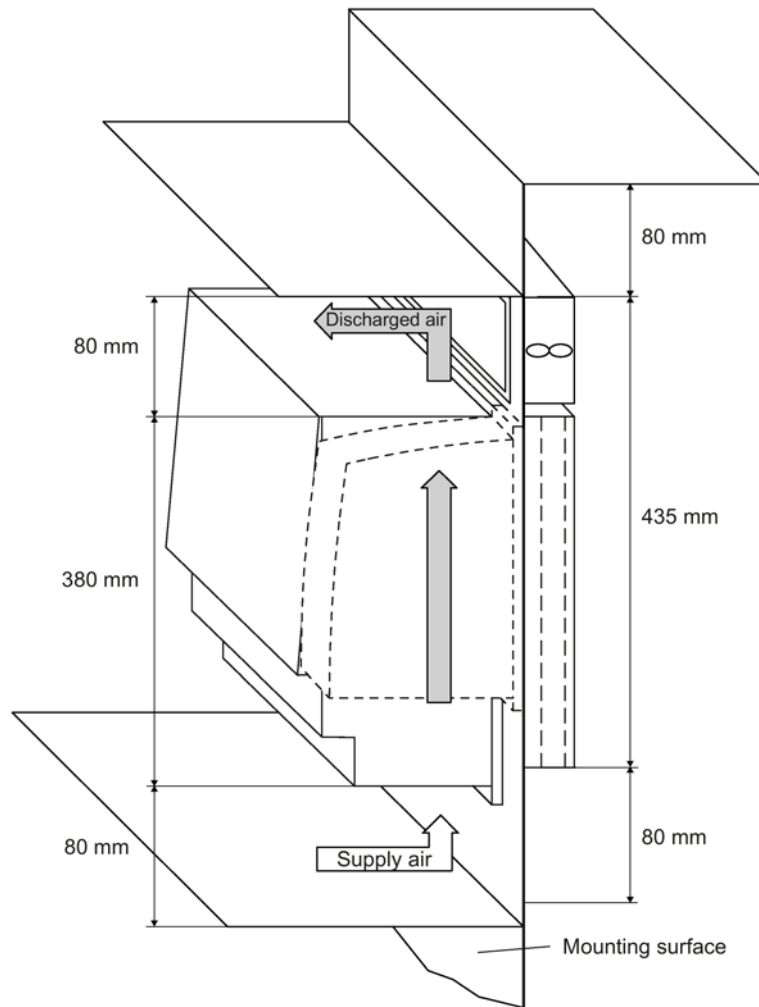

Figure 12-4 Cooling clearances for an S120 Combi Power Module with expansion axis

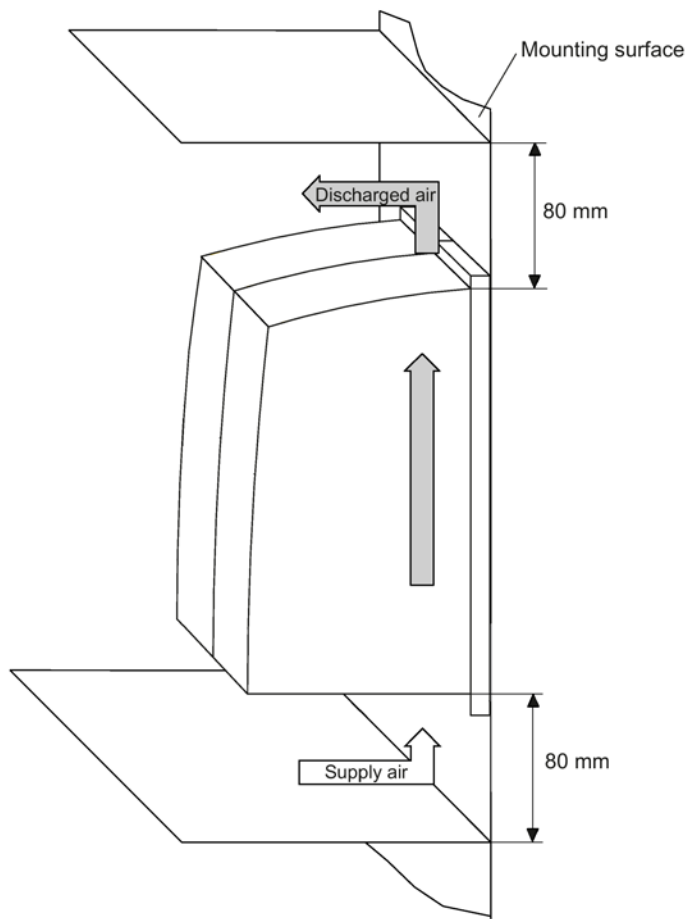

Figure 12-5 Cooling clearances for Motor Modules Booksize Compact



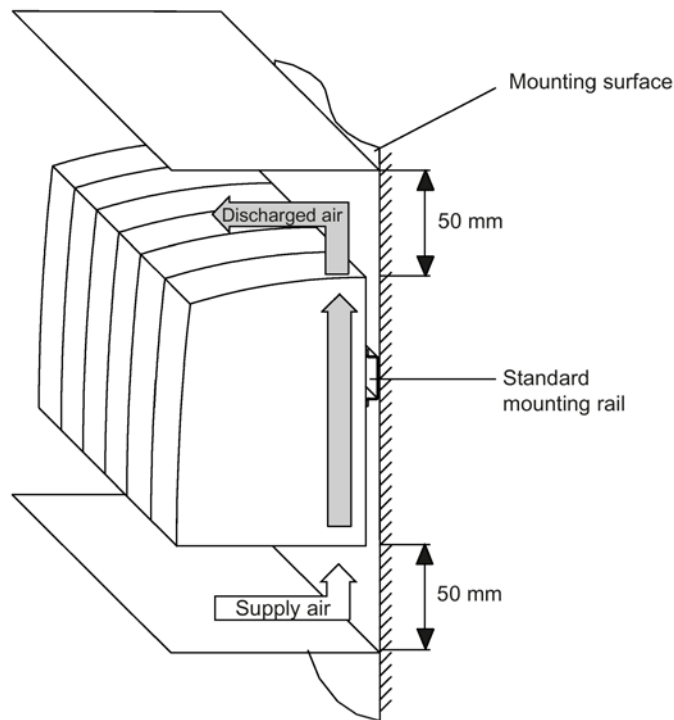

Figure 12-6 Cooling clearances for modules mounted on standard rails (e.g. SMC, DMC)

## 12.9.2 Ventilation

The S120 Combi is equipped with an internal fan to circulate the air inside the unit.

The cooling air must flow vertically through the external heat sink of the S120 Combi.

When using filter fans, heat exchangers, or air conditioners to cool the control cabinet, it must be ensured that the air is flowing in the correct direction. You must also ensure that the warm air can escape at the top. A ventilation clearance of at least 80 mm above and below must be observed.

### NOTICE

#### Damage caused by cooling equipment

Damage to components can be caused by overheating or condensation.

- Route the connected signal and power cables to the components in such a way that they do not cover the ventilation slots.
- Select the air guidance and arrangement of the cooling equipment in such a way that cold air does not blow directly onto electronic equipment and as such no condensation can form on the components. If necessary, cabinet enclosure heating may have to be installed.

**Note**

The distance between the discharge opening of the air condition equipment and the electronic equipment must be at least 200 mm.

**Note**

If the components are installed in a sealed control cabinet, an internal air cooling system must be installed in the control cabinet to circulate the air and prevent hot spots. It is best to install the fan above the components to optimize the air flow (suction).

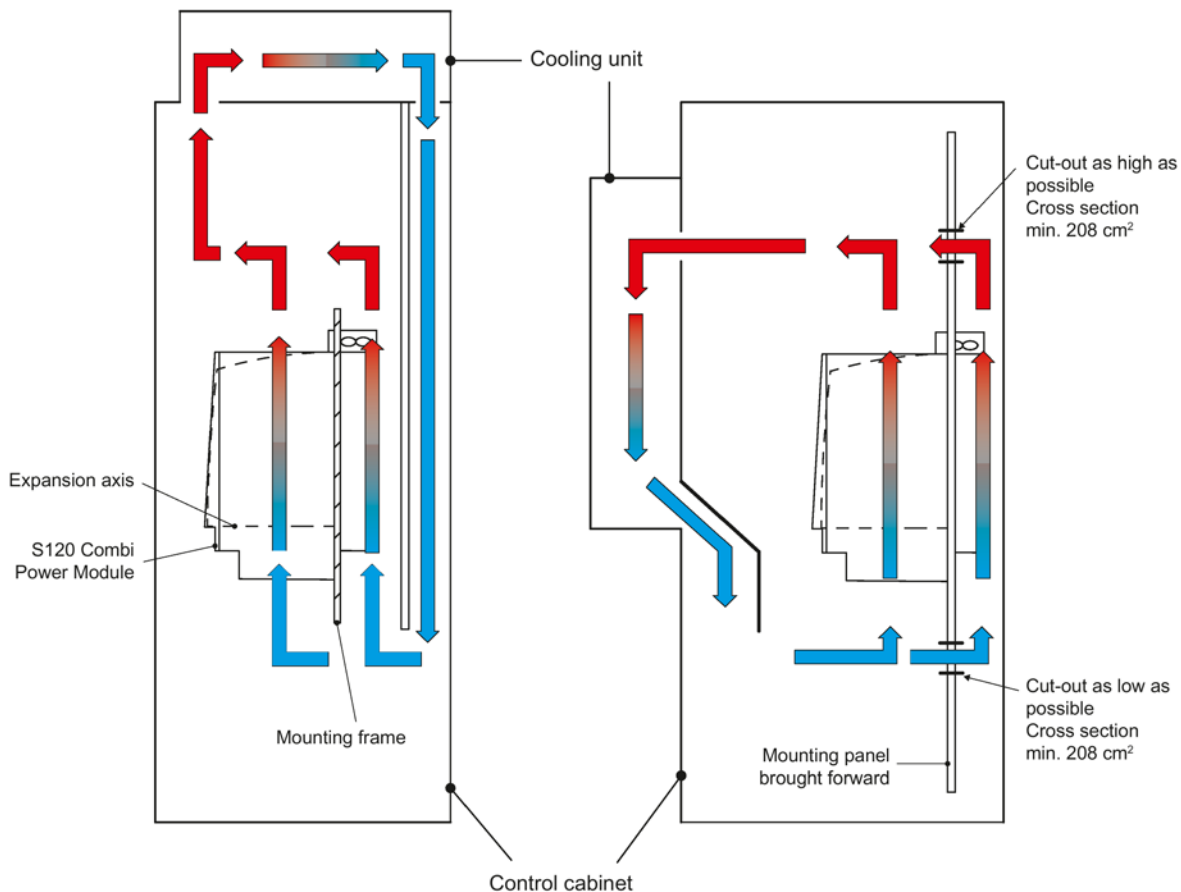

Figure 12-7 Examples of cabinet ventilation

If air conditioners are used, the relative air humidity of the expelled air increases as the air in the air conditioner cools and may exceed the dew point. If the relative humidity of the air entering the SINAMICS equipment is over 80% for an extended period of time, the insulation in the equipment may fail to function properly due to electrochemical reactions (refer to Section System overview (Page 29)). Using air baffle plates, for example, you must ensure that the cold air expelled from the air conditioner mixes with warm air in the cabinet before it enters the unit. This reduces the relative air humidity to uncritical values.

### 12.9.3 Dimensioning Climate Control Equipment

Cabinet manufacturers provide calculation programs for selecting climate control equipment. It is always necessary to know the power loss of the components and equipment installed in the cabinet.

The physical relationship is shown in the following example.

Calculating the thermal power to be dissipated:  $q = Q - k \times A \times \Delta T$

with

$q$  = thermal power that has to be dissipated using a cooling unit [W]

$Q$  = power loss [W]

$\Delta T$  = difference between the room temperature and the temperature inside the cabinet [K]

$k$  = heat transfer coefficient, e.g. sheet-steel, painted 5.5 [W/(m<sup>2</sup> \* K)]

$A$  = free-standing cabinet surface area [m<sup>2</sup>]

Table 12- 17 Example, calculating the power loss of a drive configuration

Component	Number	Total power loss [W] (including electronic losses)	Total power loss [W]
SINUMERIK 828D	1	28	28
Line filter	1	16	16
Line reactor	1	98	98
S120 Combi 3 axes Power Module 20 kW	1	634	634
Motor Module 9 A	1	100,4	100,4
Motor Module 18 A	1	185,4	185,4
SMC	2	10	20
SITOP 20	1	53	53
Line contactor	1	12	12
<b>Total:</b>			1146,8

Assumption:

free-standing control cabinet surface  $A = 5 \text{ m}^2$

difference between the room temperature and the temperature inside the control cabinet  $\Delta T = 10 \text{ K}$

$$q = 1146.8 \text{ W} - 5.5 \text{ W} / (\text{m}^2 \text{ K}) * 5 \text{ m}^2 * 10 \text{ K} = 871.8 \text{ W}$$

## 12.9.4 Power loss of components in rated operation

### 12.9.4.1 General information

The tables below provide an overview of the power loss of all components during rated operation. The characteristic values apply for the following conditions:

- Line supply voltage 400 V
- Pulse frequency of the Motor Modules 4 kHz (clock frequency of the spindle 4 kHz or 8 kHz)
- Operating components at their rated power

The total losses of the relevant components (S120 Combi, Motor Module) are calculated from the power loss and the corresponding losses from the electronics.

### 12.9.4.2 Power losses for SINUMERIK control systems, DC link components and supplementary system components

Table 12- 18 Overview of power losses at rated operation for SINUMERIK control systems, DC link components and supplementary system components

	Unit	Power loss
SINUMERIK 828D	W	28
SINUMERIK NCU 710.3 PN	W	21
SMC20/30	W	< 10
SME20/25	W	< 4
TM54F	W	4.5
Braking Module	W	20
Control Supply Module		
Line	W	70
DC link	W	65

### 12.9.4.3 Power losses for S120 Combi Power Modules

#### Power losses in rated operation

The following table provides an overview of the internal and external losses of the S120 Combi Power Modules for rated operation.

Table 12- 19 Overview of power losses in rated operation for S120 Combi Power Modules

	Unit	Internal power loss	External power loss	Total power loss <sup>1)</sup>
S120 Combi 3 axes Power Module				
16 kW / 18 A / 5 A / 5 A	W	81	344	425
16 kW / 24 A / 9 A / 9 A	W	91	446	537
20 kW / 30 A / 9 A / 9 A	W	102	532	634
S120 Combi 4 axes Power Module				
10 kW / 24 A / 12 A / 12 A / 12 A	W	115	655	770
16 kW / 18 A / 9 A / 5 A / 5 A	W	87	405	492
16 kW / 24 A / 9 A / 9 A / 9 A	W	100	507	607
20 kW / 30 A / 12 A / 9 A / 9 A	W	113	620	733

<sup>1)</sup> The external fan unit has been taken into account in the specified power losses

### 12.9.4.4 Power loss for line filters and line reactors

Table 12- 20 Overview of power loss during rated operation for line filters and line reactors

	Unit	Power loss
Line filter		
10 kW	W	12
16 kW	W	15
20 kW	W	16
Line reactors		
10 kW	W	55
16 kW	W	75
20 kW	W	98

### 12.9.4.5 Electronics losses of power units

Table 12- 21 Electronics losses for Motor Modules Booksize Compact and S120 Combi Power Modules

Component		Power loss [W]
Single Motor Module	3 A	20,4
	5 A	20,4
	9 A	20,4
	18 A	20,4
Double Motor Module	1.7 A	27,6
	3 A	27,6
	5 A	27,6
S120 Combi 3 axes Power Module <sup>1)</sup>	16 kW / 18 A / 5 A / 5 A	36,0
	16 kW / 24 A / 9 A / 9 A	36,0
	20 kW / 30 A / 9 A / 9 A	36,0
S120 Combi 4 axes Power Module <sup>1)</sup>	10 kW / 24 A / 12 A / 12 A / 12 A	38,4
	16 kW / 18 A / 9 A / 5 A / 5 A	38,4
	16 kW / 24 A / 9 A / 9 A / 9 A	38,4
	20 kW / 30 A / 12 A / 9 A / 9 A	38,4

<sup>1)</sup> Without power loss of the external fan

### 12.9.4.6 Losses in partial-load operation

#### Losses in the partial-load range for the S120 Combi

The losses of the S120 Combi in partial-load operation can be calculated using the following formula:

$$P_V = a + b + IN1 \times P1 + S1 \times I1 + S2 \times I2 + S3 \times I3 + S4 \times I4$$

With:

a: Electronics losses of the S120 Combi

b: Electronics losses of the external fan unit (Article No.: 6SL3161-0EP00-0AA0)

IN1, S1 - S4: Coefficients to calculate the power loss

P1: Infeed power [kW] (LINE X1)

I1: Spindle current [A] (SPINDLE X2)

I2: Current of the 1st feed axis (servo X3)

I3: Current of the 2nd feed axis (servo X4)

I4: Current of the 3rd feed axis (servo X5)

Table 12- 22 Overview of the coefficients to calculate the total power loss  $P_V$  in the partial-load range

Power Module	a	b	IN1	S1	S2	S3	S4
3 axes Power Module							
16 kW / 18 A	36	19.2	11.05	7.1	6.5	6.5	
16 kW / 24 A	36	19.2	11.2	7.2	7.2	7.2	
20 kW / 30 A	36	19.2	11.5	7.3	7.2	7.2	
4-axis Power Module							
10 kW / 24 A	38.4	19.2	9.1	14.3 / 7.2 <sup>1)</sup>	7.7	7.7	7.7
16 kW / 18 A	38.4	19.2	11.05	7.1	7.2	6.5	6.5
16 kW / 24 A	38.4	19.2	11.4	7.2	7.2	7.2	7.2
20 kW / 30 A	38.4	19.2	11.7	7.3	7.7	7.2	7.2

1) For a pulse frequency of 4 kHz / 8 kHz

Table 12- 23 Overview of the coefficients to calculate the power loss  $P_V$  in the control cabinet for external cooling

Power Module	a	b	IN1	S1	S2	S3	S4
3 axes Power Module							
16 kW / 18 A	36	0	1.95	0.6	0.4	0.4	
16 kW / 24 A	36	0	2.1	0.6	0.4	0.4	
20 kW / 30 A	36	0	2.03	0.6	0.4	0.4	
4-axis Power Module							
10 kW / 24 A	38.4	0	3.3	1.2 / 0.6 <sup>1)</sup>	0.4	0.4	0.4
16 kW / 18 A	38.4	0	1.95	0.6	0.4	0.4	0.4
16 kW / 24 A	38.4	0	2.3	0.6	0.4	0.4	0.4
20 kW / 30 A	38.4	0	2.23	0.6	0.4	0.4	0.4

1) For a pulse frequency of 4 kHz / 8 kHz

### Losses in the partial-load range for line reactors

The losses of the line reactors in partial-load operation can be calculated using the following formula:

$$P_v = D1 \times P1$$

With:

D1: Coefficient to calculate the power loss

P1: Infeed power [kW]

Table 12- 24 Overview of the coefficients to calculate the power loss  $P_v$  in the partial-load range

Line reactor	D1
6SL3100-0EE21-6AA0 (10 kW)	5.5
6SL3100-0EE21-6AA0 (16 kW)	4.7
6SL3100-0EE22-0AA0 (20 kW)	4.9



## Service and maintenance

### 13.1 Spare parts

#### S120 Combi spare parts list

An overview of all of the S120 Combi spare parts is provided in the table below

Table 13- 1 List of available spare parts for the S120 Combi

Designation	Order number
S120 Combi front cover	6SL3161-3FP00-0AA0
S120 Combi guiding frame for DRIVE-CLiQ cables	6SL3161-3EP00-0AA0
S120 Combi DC link lateral cover	6SL3161-3AP00-0AA0
S120 Combi drip protection grid	6SL3161-3DP00-0AA0
S120 Combi internal fan	6SL3161-0JP00-0AA0
S120 Combi external fan unit	6SL3161-0EP00-0AA0
S120 Combi accessories pack <b>Contents:</b> 24 V connector Terminal for the motor holding brake 4 DRIVE-CLiQ blanking covers 2 terminals (4-pole) for X12/X13 2 terminals (4-pole) for X21/X22 5 shield terminals for motor cables Shield terminal for EP signal cables	6SL3161-8AP00-0AA0

#### Spare parts list, additional components

You will find spare parts for all the other components and modules on the Internet (<https://support.industry.siemens.com/cs/ww/en/sc/2112>)

## 13.2 Replacing the fan

### 13.2.1 Safety instructions when replacing a fan

 **WARNING**

**Danger to life if the fundamental safety instructions and remaining risks are not carefully observed**

If the fundamental safety instructions and remaining risks in Chapter 1 (Page 21) are not observed, accidents involving severe injuries or death may occur.

- Adhere to the fundamental safety instructions.
- When assessing the risk, take into account residual risks.



 **DANGER**

**Danger to life from electric shock due to applied voltage or residual charge**

Switch off the power supply (400 V AC) before replacing the fan.

A hazardous voltage is still present for up to 5 minutes after the power supply has been switched off.

Contact with live parts can result in death or serious injury.

- Remove the device cover or the fan cover only after 5 minutes have elapsed.
- Check for zero voltage before removing the component.



 **WARNING**

**Danger to life when live parts are touched during fan replacement**

Contact with live parts while the fan is being replaced can result in death or serious injury.

- When removing the fan, you must observe the ESD regulations.
- Assign qualified personnel to install spare parts.

### 13.2.2 Replacing the Internal fan on the S120 Combi Power Module

When required, the internal S120 Combi fan can be replaced. It can be ordered as a spare part (Article number: 6SL3161-0JP00-0AA0).

#### Removing the internal fan

1. Remove the S120 Combi front cover (see Section Electrical connection of Motor Modules and DC link components (Page 193))



2. Remove the Torx-slotted screw from the fan cover.



3. Remove the fan cover.

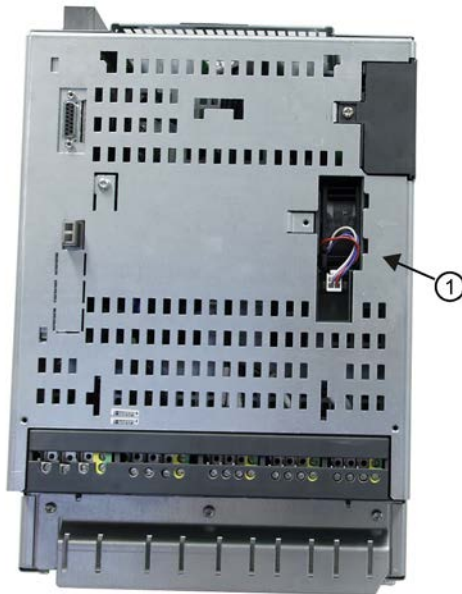

① Opened fan compartment



4. Withdraw the connector. To do so, gently press the interlock and connector together.



5. Remove the fan.

### Installing the internal fan

1. Before installing the fan, please note the airflow direction. The arrows on the fan must match the diagram shown below.



Figure 13-1 Arrows on the fan for the air flow direction

2. Install the fan.  
The connecting cables must not be crushed.
3. Connect the fan connection, until this audibly clicks into place.
4. Close the fan cover.
5. Attach the fan cover using the Torx-slotted screw.
6. Mount the front cover and attach this using the Torx-slotted screws from the front.

### 13.2.3 Replacing the fan on the Motor Modules Booksize Compact

#### Removing the fan

Size 50 mm

Size 75 mm

- Remove the Motor Module from the drive line-up.

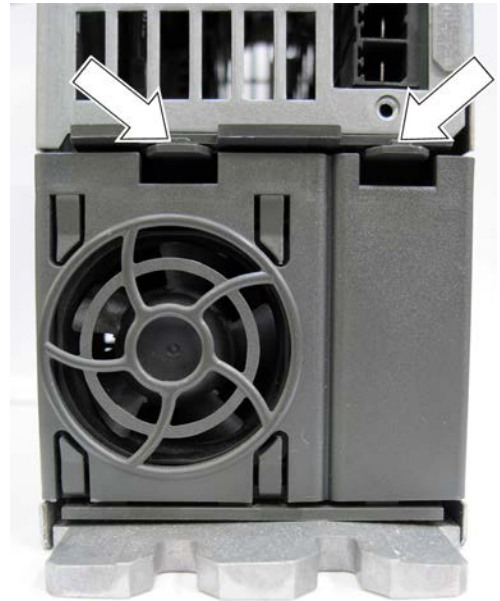

- Remove the fan cover at the lower side of the Motor Module by releasing the snap hooks.

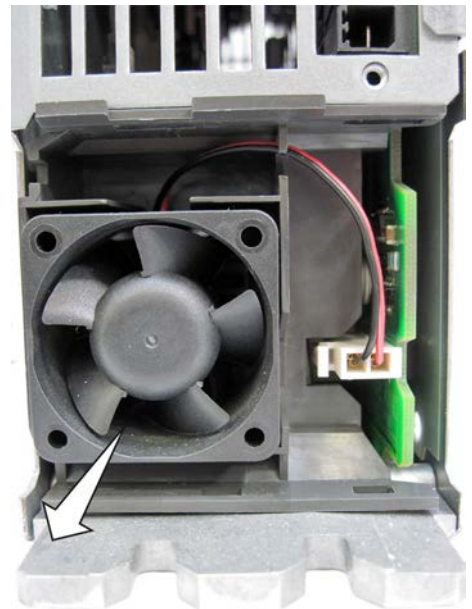

- Carefully withdraw the fan.

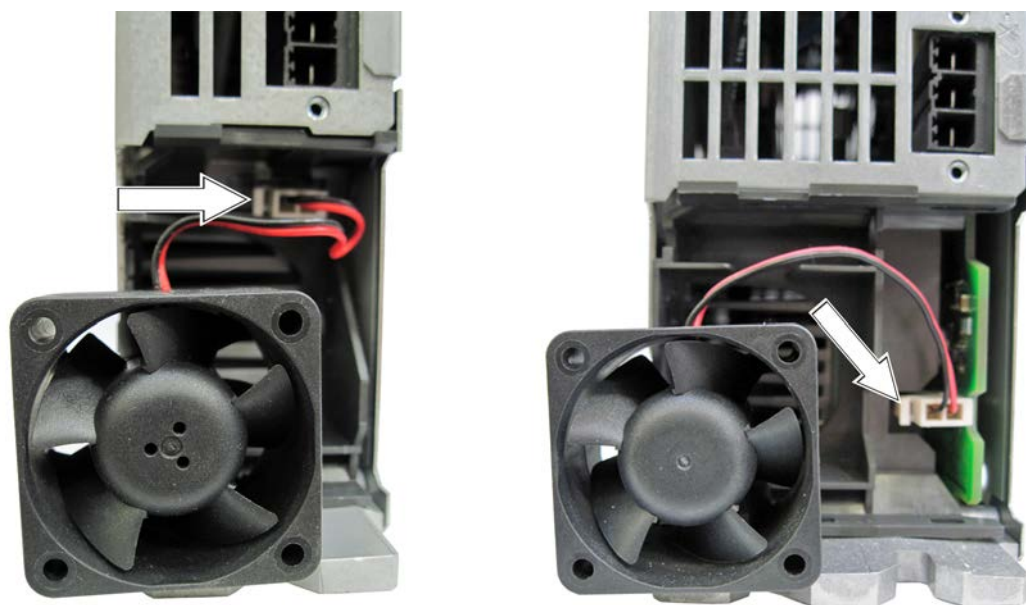

- Release the connector and remove the connecting cable.

## Installing a fan

### Size 50 mm

### Size 75 mm

- Check the air flow direction before installing the fan (the arrow on the fan must point towards the cooling ribs).

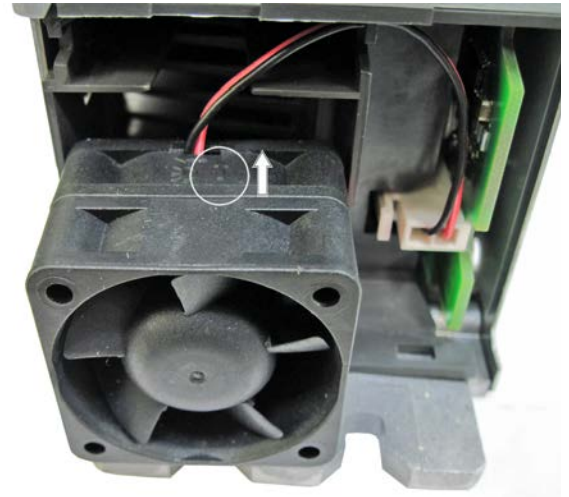

- Insert the connector until it latches into place.
- Install the fan.  
**Notice:** Do not crush the connection cables.
- Attach the fan cover.

### 13.2.4 Replacing the fan on the Control Supply Module

Replacement fan (Article number: 6SL3160-0AB00-0AA0)



 <b>WARNING</b>
<b>Danger to life caused by electric shock from another supply circuit</b>
Contact with live parts can result in death or serious injury.
<ul style="list-style-type: none"><li>• Switch off all supply circuits for this component.</li></ul>



## Removing the fan

- Remove the component from the drive line-up.
- Remove the 6 screws (Torx T10) from the enclosure cover and open the component.



- Release and withdraw the connector.
- Release the 2 screws on the fan (Torx T20).



- Remove the fan.



### Installing a fan

1. Check the air flow direction before installing the fan (the arrow on the fan must point towards the cooling ribs).
2. Insert the connector until it latches into place.
3. Screw the 2 screws on the fan (Torx T20). The tightening torque is 1.2 Nm.
4. Close the enclosure cover and screw this with 6 screws (Torx T10). The tightening torque is 0.8 Nm.

### **13.3 Cleaning the S120 Combi heat sink**

The S120 Combi heat sink should be cleaned at regular intervals using either compressed air or high-pressure water jets.

13.3 Cleaning the S120 Combi heat sink

To clean the heat sink, the air baffle plate at the rear of the S120 Combi must be removed as follows:

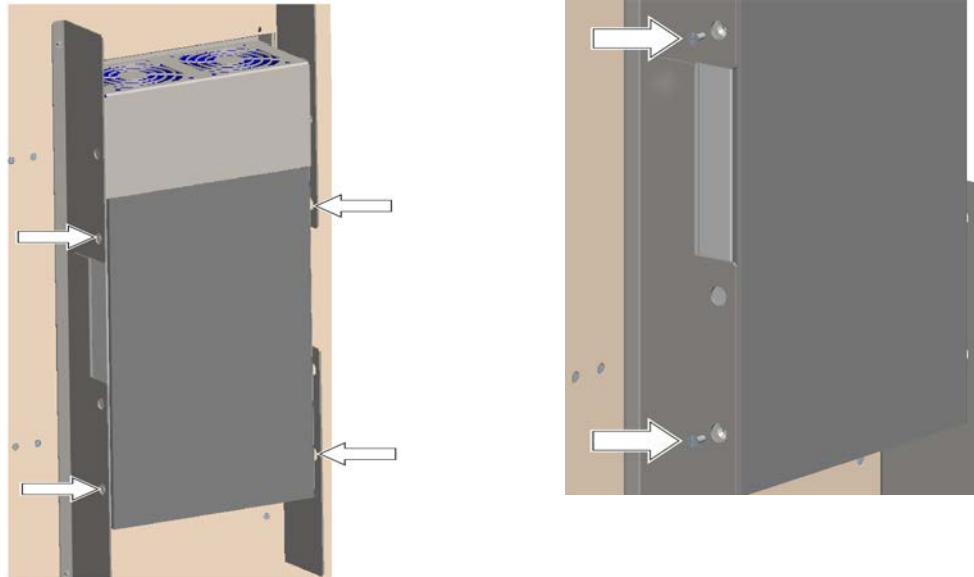

Release the fixing screws through the holes in the reinforcement plates.



Screws: Slotted or cross slot M4 x 10, DIN EN ISO 7046-1/2

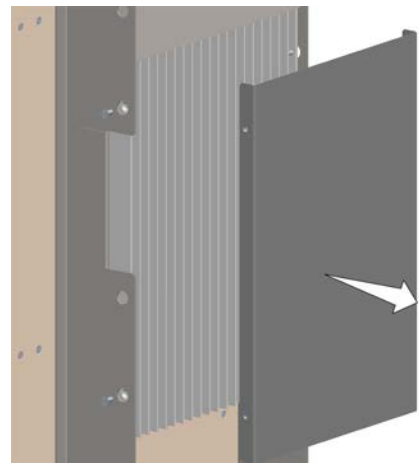
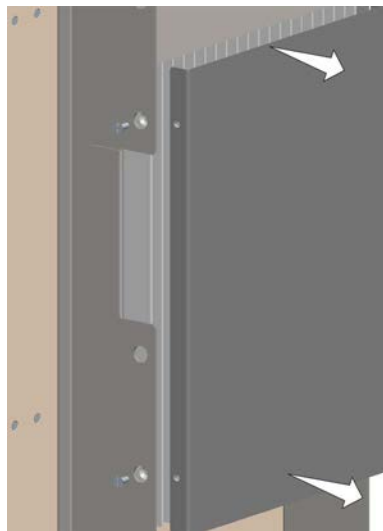

Remove the air baffle plate in the direction of the arrow.

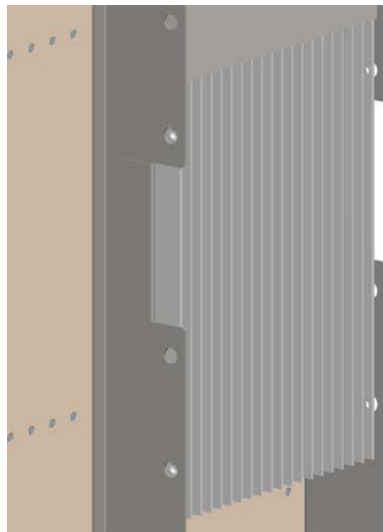

The heat sink can now be cleaned.

After cleaning the heat sink, the air baffle plate is reinstalled in reverse sequence.

**Tightening torque** for the screws: 1.8 Nm.

## 13.4 Forming the DC link capacitors

<b>NOTICE</b>
<p><b>Damage in the case of long storage periods</b></p> <p>After being in storage for more than two years, the components may suffer damage when switched on.</p> <ul style="list-style-type: none"> <li>Reform the DC link capacitors on the S120 Combi Power Modules and the Motor Modules Booksize Compact.</li> </ul>

If the cabinet is commissioned within two years of its date of manufacture, the DC link capacitors do not need to be reformed. The date of manufacture can be taken from the serial number on the rating plate.

**Note**

The storage period is calculated from the date of manufacture and not from the date that the equipment was shipped.

A defined voltage and a limited current are applied to the DC link capacitors when forming them. As a consequence, the internal relationships required for the DC link capacitors to function correctly are re-established.

### Date of manufacture

The date of manufacture can be determined from the following assignment to the serial number (e.g. T-XN2067000015 for 2009, November):

Table 13- 2 Production year and month

Character	Year of manufacture	Character	Month of manufacture
X	2009	1 ... 9	January ... September
A	2010	O	October
B	2011	N	November
C	2012	D	December
D	2013		
E	2014		
F	2015		

The serial number is found on the rating plate.

### Forming circuit

The S120 Combi Power Module has internal PTC resistors to pre-charge the DC link capacitors. The resistors can be used to form the DC link capacitors of the S120 Combi Module as well as the expansion axes (Motors Modules Booksize Compact).

During the forming process, it is not permissible for the S120 Combi Power Module to receive a switch-on command. Therefore, disconnect the 24 V power supply to the S120 Combi Power Module.

### Procedure

#### S120 Combi Power Modules

1. Connect the S120 Combi Power Module with a line reactor to the line supply (see the connection example in Section Interface description (Page 75)).
2. Keep the module connected to the line supply for approx. 1 hour without issuing a switch-on command.

#### Expansion axis (Motor Module Booksize Compact)

1. Connect the expansion axis to be formed to the DC link of the S120 Combi Power Module.
2. Connect the S120 Combi Power Module with a line reactor to the line supply (see Section Connection examples (Page 93)).
3. Keep the S120 Combi Power Module and the expansion axis connected to the line supply for approx. 1 hour without issuing a switch-on command.



### DANGER

#### **Danger to life through electric shock due to the residual charge of the DC link capacitors**

Due to the DC link capacitors, a hazardous voltage is present in the DC link for up to five minutes after the power supply has been switched off.

Contact with live parts can result in death or serious injury.

- Do not open the protective cover of the DC link until five minutes have elapsed. Ensure that you press the release catch when opening the protective cover for the DC link. A suitable tool (e.g. screwdriver or supplied release tool) must be used for this purpose.
- Only operate the S120 Combi with the DC link protective cover closed.
- Do not continue to operate damaged components.

## 13.5 Recycling and disposal

Dispose of the product according to the applicable national regulations.

The products described in this Equipment Manual are extensively recyclable on account of the low-toxic composition of the materials used. To recycle and dispose of your old device in an environmentally friendly way, please contact a company that disposes of electronic waste.





# Appendix

## A.1 List of abbreviations

---

### Note

The following list of abbreviations includes all abbreviations and their meanings used in the entire SINAMICS family of drives.

---

Abbreviation	Source of abbreviation	Significance
<b>A</b>		
A...	Alarm	Warning
AC	Alternating Current	Alternating current
ADC	Analog Digital Converter	Analog-Digital converter
AI	Analog Input	Analog input
AIM	Active Interface Module	Active Interface Module
ALM	Active Line Module	Active Line Module
AO	Analog Output	Analog output
AOP	Advanced Operator Panel	Advanced Operator Panel
APC	Advanced Positioning Control	Advanced Positioning Control
AR	Automatic Restart	Automatic restart
ASC	Armature Short Circuit	Armature short-circuit
ASCII	American Standard Code for Information Interchange	American coding standard for the exchange of information
AS-i	AS-Interface (Actuator Sensor Interface)	AS-interface (open bus system in automation technology)
ASM	Asynchronmotor	Induction motor
<b>B</b>		
BB	Betriebsbedingung	Operation condition
BERO	-	Contactless proximity switch
BI	Binector Input	Binector input
BIA	Berufsgenossenschaftliches Institut für Arbeitssicherheit	BG-Institute for Occupational Safety and Health
BICO	Binector Connector Technology	Binector connector technology
BLM	Basic Line Module	Basic Line Module

<b>Abbreviation</b>	<b>Source of abbreviation</b>	<b>Significance</b>
BO	Binector Output	Binector output
BOP	Basic Operator Panel	Basic operator panel
<b>C</b>		
C	Capacitance	Capacitance
C...	-	Safety message
CAN	Controller Area Network	Serial bus system
CBC	Communication Board CAN	Communication Board CAN
CBE	Communication Board Ethernet	PROFINET communication module (Ethernet)
CD	Compact Disc	Compact disk
CDS	Command Data Set	Command data set
CF Card	CompactFlash Card	CompactFlash card
CI	Connector Input	Connector input
CLC	Clearance Control	Clearance control
CNC	Computerized Numerical Control	Computer-supported numerical control
CO	Connector Output	Connector output
CO/BO	Connector Output / Binector Output	Connector Output / Binector Output
COB ID	CAN Object-Identification	CAN Object-Identification
CoL	Certificate of License	Certificate of License
COM	Common contact of a changeover relay	Center contact of a changeover contact
COMM	Commissioning	Startup
CP	Communication Processor	Communications processor
CPU	Central Processing Unit	Central processing unit
CRC	Cyclic Redundancy Check	Cyclic redundancy check
CSM	Control Supply Module	Control Supply Module
CU	Control Unit	Control Unit
CUA	Control Unit Adapter	Control Unit Adapter
CUD	Control Unit DC	Control Unit DC
<b>D</b>		
DAC	Digital Analog Converter	Digital analog converter
DC	Direct Current	DC current
DCB	Drive Control Block	Drive Control Block
DCBRK	DC Brake	DC braking
DCC	Drive Control Chart	Drive Control Chart
DCN	Direct Current Negative	Direct current negative
DCP	Direct Current Positive	Direct current positive
DDC	Dynamic Drive Control	Dynamic Drive Control
DDS	Drive Data Set	Drive Data Set
DI	Digital Input	Digital input
DI/DO	Digital Input / Digital Output	Digital input/output, bidirectional
DMC	DRIVE-CLiQ Hub Module Cabinet	DRIVE-CLiQ Hub Module Cabinet

<b>Abbreviation</b>	<b>Source of abbreviation</b>	<b>Significance</b>
DME	DRIVE-CLiQ Hub Module External	DRIVE-CLiQ Hub Module External
DMM	Double Motor Module	Double Motor Module
DO	Digital Output	Digital output
DO	Drive Object	Drive object
DP	Decentralized Peripherals	Distributed I/O
DPRAM	Dual-Port Random Access Memory	Dual-Port Random Access Memory
DQ	DRIVE-CLiQ	DRIVE-CLiQ
DRAM	Dynamic Random Access Memory	Dynamic Random Access Memory
DRIVE-CLiQ	Drive Component Link with IQ	Drive Component Link with IQ
DSC	Dynamic Servo Control	Dynamic Servo Control
DTC	Digital Time Clock	Timer
<b>E</b>		
EASC	External Armature Short-Circuit	External armature short-circuit
EDS	Encoder Data Set	Encoder data set
EEPROM	Electrically Erasable Programmable Read-Only Memory	Electrically Erasable Programmable Read-Only-Memory
EGB	Elektrostatisch gefährdete Baugruppen	Electrostatic sensitive devices
ELCB	Earth Leakage Circuit-Breaker	Residual current operated circuit breaker
ELP	Earth Leakage Protection	Ground-fault monitoring
EMC	Electromagnetic Compatibility	Electromagnetic compatibility
EMF	Electromotive Force	Electromotive force
EMK	Elektromotorische Kraft	Electromotive force
EMV	Elektromagnetische Verträglichkeit	Electromagnetic compatibility
EN	Europäische Norm	European Standard
EnDat	Encoder-Data-Interface	Encoder interface
EP	Enable Pulses	Pulse enable
EPOS	Einfachpositionierer	Basic positioner
ES	Engineering System	Engineering system
ESB	Ersatzschaltbild	Equivalent circuit diagram
ESD	Electrostatically Sensitive Devices	Electrostatic sensitive devices
ESM	Essential Service Mode	Essential service mode
ESR	Extended Stop and Retract	Extended stop and retract
<b>F</b>		
F...	Fault	Fault
FAQ	Frequently Asked Questions	Frequently Asked Questions
FBLOCKS	Free Blocks	Free function blocks
FCC	Function control chart	Function control chart
FCC	Flux Current Control	Flux current control
FD	Function Diagram	Function diagram
F-DI	Fail-safe Digital Input	Failsafe digital input

Abbreviation	Source of abbreviation	Significance
F-DO	Fail-safe Digital Output	Fail-safe digital output
FEPRM	Flash-EPROM	Non-volatile write and read memory
FG	Function Generator	Function Generator
FI	-	Fault current
FOC	Fiber-Optic Cable	Fiber-optic cable
FP	Funktionsplan	Function diagram
FPGA	Field Programmable Gate Array	Field Programmable Gate Array
FW	Firmware	Firmware
<b>G</b>		
GB	Gigabyte	Gigabyte
GC	Global Control	Global control telegram (broadcast telegram)
GND	Ground	Reference potential for all signal and operating voltages, usually defined as 0 V (also referred to as M)
GSD	Gerätstammdatei	Generic Station Description: Describes the features of a PROFIBUS slave
GSV	Gate Supply Voltage	Gate supply voltage
GUID	Globally Unique Identifier	Globally Unique Identifier
<b>H</b>		
HF	High Frequency	High frequency
HFD	Hochfrequenzdrossel	Radio frequency reactor
HLA	Hydraulic Linear Actuator	Hydraulic linear actuator
HLG	Hochlaufgeber	Ramp-function Generator
HM	Hydraulic Module	Hydraulic Module
HMI	Human Machine Interface	Human Machine Interface
HTL	High-Threshold Logic	Logic with high interference threshold
HW	Hardware	Hardware
<b>I</b>		
i. V.	In Vorbereitung	Under development: This property is currently not available
I/O	Input/Output	Input/output
I2C	Inter-Integrated Circuit	Internal serial data bus
IASC	Internal Armature Short-Circuit	Internal armature short-circuit
IBN	Inbetriebnahme	Startup
ID	Identifier	Identification
IE	Industrial Ethernet	Industrial Ethernet
IEC	International Electrotechnical Commission	International Electrotechnical Commission
IF	Interface	Interface
IGBT	Insulated Gate Bipolar Transistor	Insulated gate bipolar transistor
IGCT	Integrated Gate-Controlled Thyristor	Semiconductor power switch with integrated control electrode

<b>Abbreviation</b>	<b>Source of abbreviation</b>	<b>Significance</b>
IL	Impulslöschung	Pulse suppression
IP	Internet Protocol	Internet protocol
IPO	Interpolator	Interpolator
IT	Isolé Terre	Non-grounded three-phase line supply
IVP	Internal Voltage Protection	Internal voltage protection
<b>J</b>		
JOG	Jogging	Jogging
<b>K</b>		
KDV	Kreuzweiser Datenvergleich	Data cross-check
KHP	Know-How Protection	Know-how protection
KIP	Kinetische Pufferung	Kinetic buffering
Kp	-	Proportional gain
KTY84	-	Temperature sensor
<b>L</b>		
L	-	Symbol for inductance
LED	Light Emitting Diode	Light emitting diode
LIN	Linearmotor	Linear motor
LR	Lageregler	Position controller
LSB	Least Significant Bit	Least Significant Bit
LSC	Line-side converter	Line-side converter
LSS	Line-Side Switch	Line-side switch
LU	Length Unit	Length unit
LWL	Lichtwellenleiter	Fiber-optic cable
<b>M</b>		
M	-	Symbol for torque
M	Masse	Reference potential for all signal and operating voltages, usually defined as 0 V (also referred to as GND)
MB	Megabyte	Megabyte
MCC	Motion Control Chart	Motion Control Chart
MDI	Manual Data Input	Manual data input
MDS	Motor Data Set	Motor data set
MLFB	Maschinenlesbare Fabrikatebezeichnung	Machine-readable product code
MM	Motor Module	Motor Module
MMC	Man-Machine Communication	Man-machine communication
MMC	Micro Memory Card	Micro memory card
MSB	Most Significant Bit	Most significant bit
MSC	Motor Side Converter	Motor-side converter
MSCY_C1	Master Slave Cycle Class 1	Cyclic communication between master (class 1) and slave

Abbreviation	Source of abbreviation	Significance
MSC	Motorstromrichter	Motor-side converter
MT	Messtaster	Probe
<b>N</b>		
N. C.	Not Connected	Not connected
N...	No Report	No report or internal message
NAMUR	Normenarbeitsgemeinschaft für Mess- und Regeltechnik in der chemischen Industrie	Standardization association for measurement and control in chemical industries
NC	Normally Closed (contact)	NC contacts
NC	Numerical Control	Numerical control
NEMA	National Electrical Manufacturers Association	Standardization association in USA (United States of America)
NM	Nullmarke	Zero mark
NO	Normally Open (contact)	NO contacts
NSR	Netzstromrichter	Line-side converter
NVRAM	Non-Volatile Random Access Memory	Non-volatile read/write memory
<b>O</b>		
OA	Open Architecture	Software component which provides additional functions for the SINAMICS drive system
OAIF	Open Architecture Interface	Version of the SINAMICS firmware as of which the OA-application can be used
OASP	Open Architecture Support Package	Expands the STARTER commissioning tool by the corresponding OA-application
OC	Operating Condition	Operation condition
OEM	Original Equipment Manufacturer	Original equipment manufacturer
OLP	Optical Link Plug	Bus connector for fiber-optic cable
OMI	Option Module Interface	Option Module Interface
<b>P</b>		
p...	-	Adjustable parameters
P1	Processor 1	CPU 1
P2	Processor 2	CPU 2
PB	PROFIBUS	PROFIBUS
PcCtrl	PC Control	Master control
PD	PROFIdrive	PROFIdrive
PDC	Precision Drive Control	Precision Drive Control
PDS	Power Unit Data Set	Power unit data set
PE	Protective Earth	Protective ground
PELV	Protective Extra-Low Voltage	Safety extra-low voltage
PFH	Probability of dangerous failure per hour	Probability of dangerous failure per hour
PG	Programmiergerät	Programming device
PI	Proportional integral	Proportional integral
PID	Proportional integral differential	Proportional integral differential

<b>Abbreviation</b>	<b>Source of abbreviation</b>	<b>Significance</b>
PLC	Programmable Logic Controller	Programmable logic controller
PLL	Phase-locked loop	Phase-locked loop
PM	Power Module	Power Module
PMSM	Permanent-Magnet Synchronous Motor	Permanent-magnet synchronous motor
PN	PROFINET	PROFINET
PNO	PROFIBUS Nutzerorganisation	PROFIBUS user organization
PPI	Point-to-Point Interface	Point-to-point interface
PRBS	Pseudo Random Binary Signal	White noise
PROFIBUS	Process Field Bus	Serial data bus
PS	Power Supply	Power supply
PSA	Power Stack Adapter	Power Stack Adapter
PT1000	-	Temperature sensor
PTC	Positive Temperature Coefficient	Positive temperature coefficient
PTP	Point-To-Point	Point-to-point
PWM	Pulse Width Modulation	Pulse width modulation
PZD	Prozessdaten	Process data
<b>Q</b>		
<b>R</b>		
r...	-	Display parameters (read only)
RAM	Random Access Memory	Speicher zum Lesen und Schreiben
RCCB	Residual Current Circuit Breaker	Residual current operated circuit breaker
RCD	Residual Current Device	Residual current operated circuit breaker
RCM	Residual Current Monitor	Residual current monitor
REL	Reluctance motor textile	Reluctance motor textile
RESM	Reluctance Synchronous Motor	Synchronous reluctance motor
RFG	Ramp-Function Generator	Ramp-function Generator
RJ45	Registered Jack 45	Term for an 8-pin socket system for data transmission with shielded or non-shielded multi-wire copper cables
RKA	Rückkühlanlage	Cooling unit
RLM	Renewable Line Module	Renewable Line Module
RO	Read Only	Read only
ROM	Read-Only Memory	Read-only memory
RPDO	Receive Process Data Object	Receive Process Data Object
RS232	Recommended Standard 232	Interface standard for a cable-connected serial data transmission between a sender and receiver (also known as EIA232)
RS485	Recommended Standard 485	Interface standard for a cable-connected differential, parallel, and/or serial bus system (data transmission between a number of senders and receivers, also known as EIA485)

<b>Abbreviation</b>	<b>Source of abbreviation</b>	<b>Significance</b>
RTC	Real-Time Clock	Real-time clock
RZA	Raumzeigerapproximation	Space-vector approximation
<b>S</b>		
S1	-	Continuous operation
S3	-	Intermittent duty
SAM	Safe Acceleration Monitor	Safe acceleration monitoring
SBC	Safe Brake Control	Safe brake control
SBH	Sicherer Betriebshalt	Safe operating stop
SBR	Safe Brake Ramp	Safe brake ramp monitoring
SBT	Safe Brake Test	Safe brake test
SCA	Safe Cam	Safe cam
SCC	Safety Control Channel	Safety Control Channel
SD Card	SecureDigital Card	Secure digital memory card
SDC	Standard Drive Control	Standard Drive Control
SDI	Safe Direction	Safe motion direction
SE	Sicherer Software-Endschalter	Safe software limit switch
SESM	Separately Excited Synchronous Motor	Separately excited synchronous motor
SG	Sicher reduzierte Geschwindigkeit	Safely-limited speed
SGA	Sicherheitsgerichteter Ausgang	Safety-related output
SGE	Sicherheitsgerichteter Eingang	Safety-related input
SH	Sicherer Halt	Safe stop
SI	Safety Integrated	Safety Integrated
SIC	Safety Info Channel	Safety Info Channel
SIL	Safety Integrity Level	Safety Integrity Level
SITOP	-	Siemens power supply system
SLM	Smart Line Module	Smart Line Module
SLP	Safely Limited Position	Safely Limited Position
SLS	Safely-Limited Speed	Safely-limited speed
SLVC	Sensorless Vector Control	Sensorless vector control
SM	Sensor Module	Sensor Module
SMC	Sensor Module Cabinet	Sensor Module Cabinet
SME	Sensor Module External	Sensor Module External
SMI	SINAMICS Sensor Module Integrated	SINAMICS Sensor Module Integrated
SMM	Single Motor Module	Single Motor Module
SN	Sicherer Software-Nocken	Safe software cam
SOS	Safe Operating Stop	Safe operating stop
SP	Service Pack	Service pack
SP	Safe Position	Safe position
SPC	Setpoint Channel	Setpoint channel
SPI	Serial Peripheral Interface	Serial peripheral interface



<b>Abbreviation</b>	<b>Source of abbreviation</b>	<b>Significance</b>
SPS	Speicherprogrammierbare Steuerung	Programmable logic controller
SS1	Safe Stop 1	Safe Stop 1 (monitored for time and ramp)
SS1E	Safe Stop 1 External	Safe Stop 1 with external stop
SS2	Safe Stop 2	Safe Stop 2
SS2E	Safe Stop 2 External	Safe Stop 2 with external stop
SSI	Synchronous Serial Interface	Synchronous serial interface
SSM	Safe Speed Monitor	Safe feedback from speed monitor
SSP	SINAMICS support package	SINAMICS support package
STO	Safe Torque Off	Safe torque off
STW	Steuerwort	Control word
<b>T</b>		
TB	Terminal Board	Terminal Board
TEC	Technology Extension	Software component which is installed as an additional technology package and which expands the functionality of SINAMICS (previously OA-application)
TIA	Totally Integrated Automation	Totally Integrated Automation
TM	Terminal Module	Terminal Module
TN	Terre Neutre	Grounded three-phase line supply
Tn	-	Integral time
TPDO	Transmit Process Data Object	Transmit Process Data Object
TT	Terre Terre	Grounded three-phase line supply
TTL	Transistor-Transistor Logic	Transistor-Transistor-Logik
Tv	-	Rate time
<b>U</b>		
UL	Underwriters Laboratories Inc.	Underwriters Laboratories Inc.
UPS	Uninterruptible Power Supply	Uninterruptible power supply
USV	Unterbrechungsfreie Stromversorgung	Uninterruptible power supply
UTC	Universal Time Coordinated	Universal time coordinated
<b>V</b>		
VC	Vector Control	Vector control
Vdc	-	DC-link voltage
VdcN	-	Partial DC-link voltage negative
VdcP	-	Partial DC-link voltage positive
VDE	Verband Deutscher Elektrotechniker	Verband Deutscher Elektrotechniker [Association of German Electrical Engineers]
VDI	Verein Deutscher Ingenieure	Verein Deutscher Ingenieure [Association of German Engineers]
VPM	Voltage Protection Module	Voltage Protection Module
Vpp	Volt peak to peak	Volt peak to peak
VSM	Voltage Sensing Module	Voltage Sensing Module

<b>Abbreviation</b>	<b>Source of abbreviation</b>	<b>Significance</b>
<b>W</b>		
WEA	Wiedereinschaltautomatik	Automatic restart
WZM	Werkzeugmaschine	Machine tool
<b>X</b>		
XML	Extensible Markup Language	Extensible markup language (standard language for Web publishing and document management)
<b>Y</b>		
<b>Z</b>		
ZK	Zwischenkreis	DC link
ZM	Zero Mark	Zero mark
ZSW	Zustandswort	Status Word

## A.2 Documentation overview

General documentation/catalogs			
SINAMICS	G110	D11.1	- Inverter built-in units 0.12 kW up to 3 kW
	G120	D31	- SINAMICS Inverters for Single-Axis Drives and SIMOTICS Motors
	G130, G150	D11.1	- Inverter built-in units - Inverter cabinet units
	S120, S150	D21.3	- SINAMICS S120 Built-in units in the Chassis format and Cabinet Modules - SINAMICS S150 Drive Converter Cabinet Units
SIMOTION, SINAMICS	S120	PM21	- SIMOTION, SINAMICS S120 and Motors for Production Machines
Manufacturer/service documentation			
SINAMICS	G110		- Getting Started - Operating instructions - List Manuals
	G120		- Getting Started - Operating instructions - Hardware Installation Manuals - Function Manual Safety Integrated - List Manuals
	G130		- Operating instructions - List Manual
	G150		- Operating instructions - List Manual
	GM150, SM120/SM150, GL150, SL150		- Operating instructions - List Manuals
	S110		- Manual - Getting Started - Function Manual - List Manual
	S120		- Getting Started with STARTER - Commissioning Manual with STARTER - Getting Started with Startdrive (available as of Startdrive V14 release) - Commissioning Manual with Startdrive (available as of Startdrive V14 release) - Commissioning Manual CANopen - Function Manual Drive Functions - Function Manual Safety Integrated - Function Manual DCC - List Manual - Manual Control Unit and supplementary system components - Manual LT Booksize - Manual LT Booksize C/D Type - Manual LT Chassis air-cooled - Manual LT Chassis liquid-cooled - Manual Combi - Manual Cabinet Modules - Manual AC Drive - SINAMICS S120M Manual Distributed Drive Technology - SINAMICS HLA System Manual Hydraulic Drive
	S150		- Operating instructions - List Manual
Motors			- Configuration Manuals, Motors
General			- Configuration Manual, EMC Guidelines



# Index

## A

Autotransformer, 62

## B

Braking Module, 175  
Braking Module Booksize  
    Connection example, 182

## C

Cable Installation, 291  
Cleaning the S120 Combi heat sink, 331  
Components  
    Braking Module, 175  
    Control Supply Module CSM, 161  
    DME20 DRIVE-CLiQ Hub Module, 229  
    DRIVE-CLiQ cabinet bushing, 279  
    DRIVE-CLiQ coupling, 284  
    DRIVE-CLiQ Hub Module DMC20, 222  
    Line filter, 43  
    Line reactors, 48  
    Motor Module Booksize Compact, 139  
    S120 Combi Power Modules, 67  
    Sensor Module Cabinet-Mounted SMC30, 247  
    Sensor Module External SME20, 263  
    Sensor Module External SME25, 271  
    Terminal Module TM54F, 203  
Connection examples  
    Braking Module Booksize, 182  
Control Supply Module CSM, 161  
Current consumption (24 V DC), 298

## D

Derating characteristics  
    Motor Modules Booksize Compact, 159  
Diagnostics via LEDs  
    Braking Module Booksize, 183  
    Control Supply Module, 170  
    DRIVE-CLiQ Hub Module DMC20, 226  
    Motor Module Booksize Compact, 150  
    S120 Combi Power Modules, 96  
    Sensor Module Cabinet SMC20, 243

    Sensor Module Cabinet SMC30, 254  
    Terminal Module TM54F, 217  
Dimension drawings  
    Braking Module Booksize, 184  
    Braking resistors for Braking Modules, 190  
    Control Supply Module, 171  
    DRIVE-CLiQ cabinet bushing, 281  
    DRIVE-CLiQ coupling, 285  
    DRIVE-CLiQ Hub Module DMC20, 227  
    DRIVE-CLiQ Hub Module External DME20, 234  
    Line filter, 47  
    Line reactors, 52  
    Motor Modules Booksize Compact, 151  
    S120 Combi Power Modules, 97  
    Sensor Module Cabinet SMC20, 244  
    Sensor Module Cabinet SMC30, 255  
    Sensor Module External SME20, 267  
    Sensor Module External SME25, 274  
    Terminal Module TM54F, 219  
DME20 DRIVE-CLiQ Hub Module, 229  
Drip protection grid, 107  
DRIVE-CLiQ cabinet bushing, 279  
DRIVE-CLiQ cable, 301  
DRIVE-CLiQ coupling, 284  
DRIVE-CLiQ Hub Module DMC20, 222  
Duty cycles  
    Braking Module Booksize, 187

## E

Electronics power supply, 32  
EMC Directive, 289  
Environmental conditions, 32  
Equipotential bonding, 308  
Expansion axes, 71

## H

Heat dissipation, 310

## I

Installation  
    Braking Module Booksize, 185  
    DRIVE-CLiQ cabinet bushing, 283  
    DRIVE-CLiQ coupling, 286  
    DRIVE-CLiQ Hub Module DMC20, 228

- Motor Module Booksize Compact, 154
- S120 Combi Power Modules, 99
- Sensor Module Cabinet, 244, 256
- Sensor Module External SME20/SME25, 268, 275
- Terminal Modules, 220

Interface descriptions

- Braking Module Booksize, 179
- Control Supply Module, 164
- DRIVE-CLiQ cabinet bushing, 280
- DRIVE-CLiQ cabinet bushing M12, 280
- DRIVE-CLiQ coupling, 285
- DRIVE-CLiQ Hub Module DMC20, 224
- DRIVE-CLiQ Hub Module External DME20, 231
- Line filter, 46
- Line reactors, 50
- Motor Modules Booksize Compact, 143
- S120 Combi 3 axes Power Module, 76
- S120 Combi 4 axes Power Module, 78
- Sensor Module Cabinet SMC20, 239
- Sensor Module Cabinet SMC30, 248
- Sensor Module External SME20, 264
- Sensor Module External SME25, 271
- Terminal Module TM54F, 205

Isolating transformer, 64

**L**

LEDs

- Braking Module Booksize, 183
- Control Supply Module, 170
- DRIVE-CLiQ Hub Module DMC20, 226
- Motor Module Booksize Compact, 150
- S120 Combi Power Modules, 96
- Sensor Module Cabinet SMC20, 243
- Sensor Module Cabinet SMC30, 254
- Terminal Module TM54F, 217

- Line connection, 37
- Line connection voltage, 32
- Line Connections, 55
- Line disconnectors, 38
- Line filter, 43
- Line frequency, 32
- Line reactors, 48
- Line supply types, 32

**M**

MOTION-CONNECT cables

- DRIVE-CLiQ signal cables, 301
- Power cables, 302

Motor Module Booksize Compact, 139

Motors

- Line connection, 56

**O**

- Overcurrent protection
  - Line side, 38
  - Solid-state circuit, 297
- Overvoltage protection, 42

**P**

- Power cables, 302
- Power loss, 316
- Power loss calculation, 315
- Power Supply Units, 300
- Product-specific safety instructions
  - Sensor Module Cabinet SMC20, 237
- Protective conductor connection and shield support
  - Terminal Module TM54F, 221

**R**

- Rated duty cycles
  - Motor Modules Booksize Compact, 157
  - S120 Combi Power Modules, 123
- Replacing the fan
  - Control Supply Module CSM, 328
  - S120 Combi - internal fan, 322
- Residual-current operated circuit breakers, 40

**S**

- S120 Combi Power Modules, 67
- Safety instructions
  - Braking resistors, 189
  - DRIVE-CLiQ Hub Module DMC20, 223
- Sensor Module Cabinet-Mounted SMC30, 247
- Sensor Module External SME20, 263
- Sensor Module External SME25, 271
- Spare parts, 321
- Specification of encoder systems and encoders
  - Sensor Module Cabinet SMC30, 89, 258
- Storage, 32
- System data, 32

**T**

- Technical data
  - Braking Module Booksize, 186

Braking resistors without a thermostatic switch, 192  
Control Supply Module, 173  
Double Motor Modules Booksize Compact, 156  
DRIVE-CLiQ cabinet bushings, 284  
DRIVE-CLiQ coupling, 286  
DRIVE-CLiQ Hub Module DMC20, 229  
DRIVE-CLiQ Hub Module External DME20, 235  
Line filter, 48  
Line reactors, 53  
S120 Combi 3 axes Power Modules, 119  
S120 Combi 4 axes Power Modules, 121  
Sensor Module Cabinet SMC20, 246  
Sensor Module Cabinet SMC30, 258  
Sensor Module External SME20, 269  
Sensor Module External SME25, 276  
Single Motor Modules Booksize Compact, 155  
Terminal Module TM54F, 222  
Terminal Module TM54F, 203  
Transport, 32

Siemens AG  
Digital Factory  
Motion Control  
Postfach 3180  
91050 ERLANGEN  
GERMANY

Subject to change

[www.siemens.com/motioncontrol](http://www.siemens.com/motioncontrol)