

Datasheet Filter Cap SF2

For Humidity and Temperature Sensor SHT2x

- Protection against dust and particles
- Protection against water immersion
- Designed to match on SHT2x DFN type sensors
- Optimized for response time of sensor



Product Summary

The filter cap SF2 protects SHT2x humidity and temperature sensors against dust, water immersion as well as against contamination by particles. The cavity inside is made such that the volume between membrane and sensor is kept minimal and hence the impact on response time for humidity measurements is reduced to a minimum. The filter cap SF2 is available in black color with a black filter membrane.

The filter cap SF2 is made of a single piece of Polybutylene Terephthalate (PBT) with a filter membrane welded on it. The SF2 filter cap is designed to be mounted after soldering by clipping the four pins into openings in the PCB. Together with the sensor it provides a compact entity which may serve as an adaptor to the device housing. Adding adhesive for seal to PCB and using an o-ring it serves for a waterproof mounting solution.

Dimensions

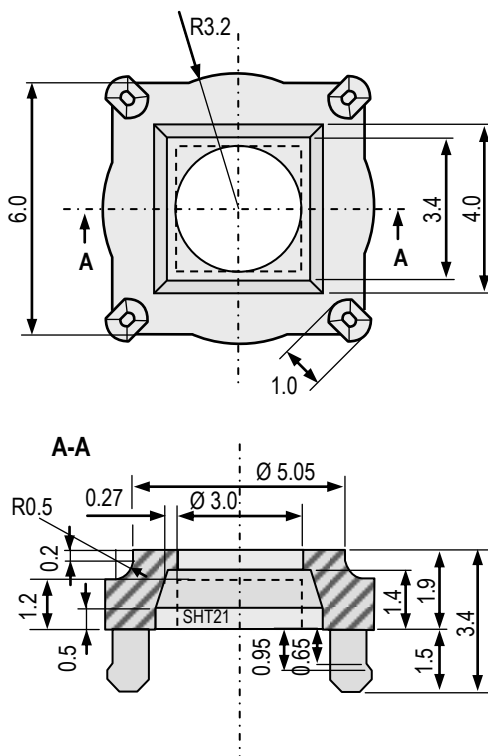

Figure 1: Drawing of the filter cap SF2 (body only). Dimensions are given in mm (1mm = 0.039inch), tolerances are ± 0.1 mm. Add 0.15 to total height due to the filter membrane. The cavity inside the cap fits to SHT2x sensors. Additional space for solder joints are left open around the sensor.

Technical Specifications

Parameter	Value
Operating Range	-40 ... 125°C
IP ¹	IP67
RoHS	Compliant
Body material	Polybutylene Terephthalate (PBT)
Body Color	Black
UL94 (Body material only)	UL94 V-0 (0.73mm)
Filter material	PTFE with polyester scrim
Filter Color	Black
Filter Thickness	0.13 mm
Filter pore size	1.5 μ m
Filtration efficiency ²	99.99%
Oleophobic Rating (Filter) ³	8
Mullen Hydrostatic	>100mbar (>1m water)

¹ IP67: dust tight, protected against harmful water immersion up to 1m water column. (<http://en.wikipedia.org/wiki/IP67>) .

To achieve IP67 at the connections between the housing or the PCB and the SF2 is up to the customer.

² 0.1 μ m particles at 0.05m/s air flow.

³ Repellence of oil and hydrocarbons according to AATCC 118-1992 standard. Rating goes from 0 – 8 while 8 is most repellent.

User's Guide Filter Cap SF2

Mounting Instruction

The filter cap SF2 is mounted to the PCB after soldering the SHT2x sensor by clipping the four pins into the openings in the PCB. The filter cap may be fixed by adhesive or by the force of the pins itself – compare Figure 2. By choosing different distances between the openings the SF2 either clips itself on the PCB by mechanical force or the pins can be used for positioning only – compare Figure 3. The recommended PCB thickness for mounting with clips is $\geq 0.8\text{mm}$. Please note that when mounting the filter cap with clips, a hermetic seal between filter cap and PCB cannot be guaranteed. This should be considered for applications in which the filter cap is used to seal the volume around the sensor against surrounding volume which is enclosed by a housing (compare Figure 2). For further information on handling and assembly of SF2 filter caps please refer to the application Note “Handling and Assembly of SF2 Filter Cap”.

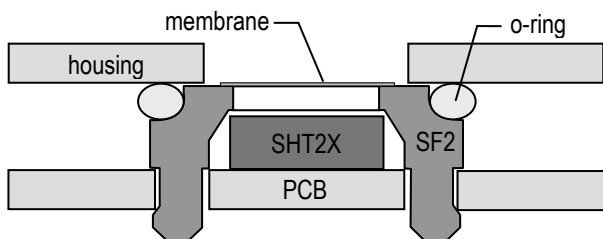

Figure 2: Side view of SF2 filter cap mounted between PCB and housing wall. The volume below membrane is kept minimal and the is separated from surrounding volume enclosed by housing.

Measures for higher protection

For hermetic seal, adhesive must be added between filter cap and PCB. Such seal provides higher security against water leakage, condensation inside the housing, and corrosion of the soldering pads of the sensor. If corrosion of the solder contacts is a potential problem, it is recommended to cover the solder joints with adhesive as well. For further information on application of adhesives with SF2 filter caps, please refer to the application Note “Handling and Assembly of SF2 Filter Cap”.

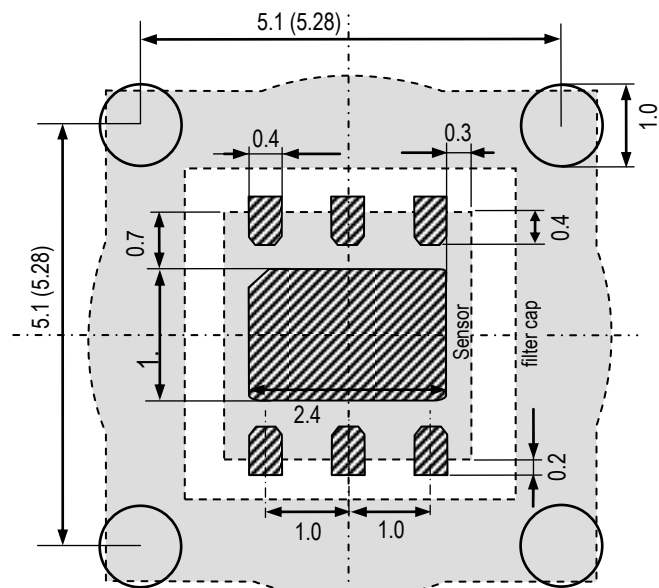

Figure 3: PCB layout of SHT2x and filter cap SF2. Dimensions are given in mm (1mm = 0.039 inch). The distance of the openings is 5.1mm $\pm 0.05\text{mm}$ if the sensor should clip on the PCB and 5.28mm if the pins are used for adjustment only. By varying the openings distance about $\pm 0.05\text{mm}$ the clipping force may be adjusted.

Mounting against housing wall

The filter cap SF2 not only protects against dust and water immersion, it also helps to mount the sensor to the housing wall. If mounted to a housing wall towards the outside, the sensor is perfectly exposed to the environment of which humidity and temperature shall be measured.

In order to protect the inside of the device housing against water immersion it is recommended to place an o-ring between filter cap and housing wall – compare Figure 2.

For such o-rings Sensirion recommends the following specifications:

- Inner diameter: 5mm
- Cross section: 1mm
- Material: NBR

Important: Please ensure that the air path to the measured volume is not blocked by another membrane. This may increase response time of the sensor dramatically.