

1. Mount the sensor with the darkest object at the longest application distance. The distance to the object must be less than shown in [Figure 7](#) on page 6 for your object color.
2. Turn the adjustment potentiometer counter-clockwise until the yellow indicator turns **off** (5 turns maximum).
3. Turn the adjustment potentiometer clockwise until the yellow indicator turns on.
4. Replace the darkest object with the brightest background at the closest application distance.
5. Turn the adjustment potentiometer clockwise, counting the revolutions, until the yellow indicator turns on.
6. Turn the adjustment potentiometer counter-clockwise half of the number of turns from step 5. This places the **cutoff** distance midway between the object and the background switchpoints (see [Figure 3](#) on page 3).

The sensor is ready for operation.

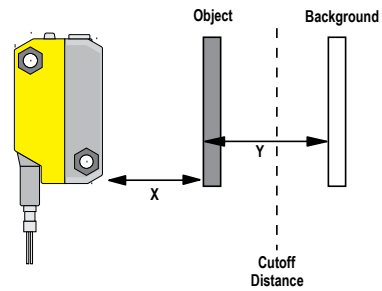

X: Distance to the Object

Y: Minimum Separation Between the Object and the Background

Figure 3.

Set the **cutoff** distance approximately midway between the farthest object and the closest background

Setup Example

An object with a reflectivity similar to black paper is set 150 mm away from the sensor. A background with a reflectivity similar to white paper is set 200 mm away from the sensor. According to [Figure 7](#) on page 6, the minimum separation distance between the object and the background is 12 mm. In this application, reliable detection is achieved when set up according to the procedure outlined in [Sensor Setup - Background Suppression](#) on page 2.

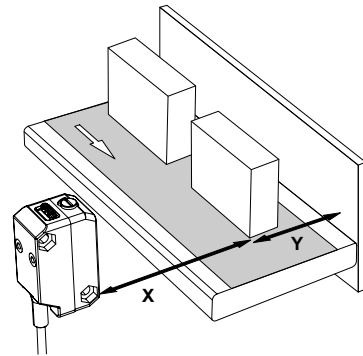

Figure 4. Background Suppression Mode Application Example

1. Object
 2. Conveyor
 3. Background
- X: Distance to the Object = 150 mm
 Y: Minimum Separation Between the Object and the Background > 12 mm

Output States

Background Suppression Mode				
Sensor Model Type	Output	Object Inside Minimum Sensing Range	Object Between Minimum Sensing Range and Cutoff Distance	Object Beyond Cutoff Distance
All Models	Yellow Indicator Light	Undefined	ON	OFF
Complementary Models	Black Wire (Pin 4)	Undefined	ON	OFF
	White Wire (Pin 2)	Undefined	OFF	ON
Bipolar Models	Black Wire (Pin 4)	Undefined	ON	OFF
	White Wire (Pin 2)	Undefined	ON	OFF

Specifications

Supply Voltage

10 to 30 V dc (10% maximum ripple within specified limits) at less than 16 mA, exclusive of load

Sensing Beam

Visible red LED, 640 nm

Supply Protection Circuitry

Protected against reverse polarity and transient voltages

Output Configuration

Solid-state complementary: NPN or PNP (current sinking or sourcing), or bipolar (both sinking and sourcing) depending on model;

Rating: 100 mA total output current

Off-state leakage current: < 50 µA at 30 V dc

ON-state saturation voltage: < 1.5 V at 10 mA; < 3.0 V at 100 mA

Protected against false pulse on power-up and continuous overload or short circuit of outputs

Required Overcurrent Protection



WARNING: Electrical connections must be made by qualified personnel in accordance with local and national electrical codes and regulations.

Overcurrent protection is required to be provided by end product application per the supplied table.

Overcurrent protection may be provided with external fusing or via Current Limiting, Class 2 Power Supply.

Supply wiring leads < 24 AWG shall not be spliced.

For additional product support, go to www.bannerengineering.com.

Supply Wiring (AWG)	Required Overcurrent Protection (Amps)
20	5.0
22	3.0
24	2.0
26	1.0
28	0.8
30	0.5

Output Response

2.8 millisecond ON/OFF

Note: 200 millisecond delay on power-up; outputs do not conduct during this time

Adjustments

Five-turn adjustment screw sets cutoff distance between min. and max. positions, clutched at both ends of travel

Repeatability

250 µs

Indicators

2 LED indicators on sensor top:

Green solid: Power on

Amber solid: Light sensed

Amber flashing: Marginal sensing condition

Construction

ABS housing, acrylic lens cover; PVC cable, nickel-plated brass connector, acetal adjustment pot

Environmental Rating

IEC IP67; NEMA 6; UL Type 1

Connections

2 m (6.5 ft) 4-wire PVC cable, 9 m (30 ft) PVC cable, or 4-pin Pico-style or Euro-style 150 mm (6 in) pigtail QD, depending on model

Operating Conditions

Relative Humidity: 95% relative humidity at 50 °C (non-condensing)

Temperature: -20 °C to 55 °C (-4 °F to 131 °F)

Application Notes

For mirror-like objects, minimize the sensor to object mounting distance and tilt the sensor so reflected light is directed away from the sensor when the object is present.

Certifications

