

Sensor Setup - Foreground Suppression

Foreground Suppression Mode (also called Background **Detection**): The light reflected off the background is detected. The output changes when the light from the background is blocked.

In general, if the background is fixed and the color or shape of the objects in the foreground vary, foreground suppression mode will provide reliable detection. A foreground suppression sensor uses the background in the same way a retroreflective sensor would use a reflector. The sensor output will change whenever an object passes between itself and the background.

To ensure reliable foreground suppression, a minimum separation distance between the object and the background is necessary. See [Figure 6](#) on page 6 to determine the minimum separation distance.

1. Mount the sensor within 200 mm of the fixed background.
2. Turn the adjustment potentiometer clockwise until it clicks (5 turns).
3. Turn the adjustment potentiometer counter-clockwise until the yellow indicator turns on. This places the cutoff distance in front of the fixed background (see [Figure 3](#) on page 3).
4. Place the application's darkest object into the sensor's field of view at the maximum sensor to the object distance, and verify that the yellow indicator turns **off**. The sensor is optimized for detecting thin objects close to the fixed background and is ready for operation.

For maximum sensing reliability in applications with variations in background position or color (for example, conveyor belts with flutter), follow these additional steps.

5. Continuing from step 4, turn the adjustment potentiometer counter-clockwise, counting the revolutions, until the yellow indicator turns on.
6. Turn the adjustment potentiometer clockwise half the number of revolutions from step 5. This places the cutoff distance midway between the object and the background. The sensor is optimized for reliable detection in applications with thick objects and modest variation in background. The sensor is ready for operation.

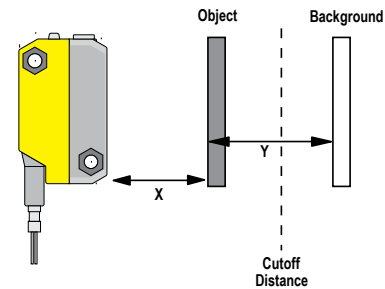

X: Distance to Background

Y: Minimum Separation Between Object and Background

Figure 3. Set the cutoff distance in front of the fixed background

Setup Example

The sensor is positioned above a black conveyor belt at a distance of 150 mm. The objects on the conveyor are boxes of varying colors. According to [Figure 6](#) on page 6, the box height must be greater than 10 mm for reliable detection against a black background. In this application, reliable detection will be achieved when set up according to the procedure outlined in [Sensor Setup - Foreground Suppression](#) on page 3.

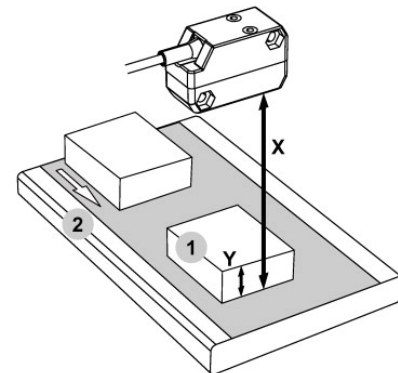

Figure 4. Foreground Suppression Mode application example

1. Object

2. Background (Conveyor)

X: Distance to Background = 150 mm

Y: Minimum Separation Between Object and Background > 10 mm

Output States

Foreground Suppression Mode			
Sensor Model Type	Output	Object Between Sensor Face and Cutoff Distance	No Object Between Sensor Face and Fixed Background
All Models	Yellow Indicator Light	OFF	ON
Complementary Models	Black Wire (Pin 4)	OFF	ON
	White Wire (Pin 2)	ON	OFF
Bipolar Models	Black Wire (Pin 4)	OFF	ON
	White Wire (Pin 2)	OFF	ON

Specifications

Supply Voltage

10 to 30 V dc (10% maximum ripple within specified limits) at less than 16 mA, exclusive of load

Sensing Beam

Visible red LED, 640 nm

Supply Protection Circuitry

Protected against reverse polarity and transient voltages

Output Configuration

Solid-state complementary: NPN or PNP (current sinking or sourcing), or bipolar (both sinking and sourcing) depending on model;
Rating: 100 mA total output current

Off-state leakage current: < 50 µA at 30 V dc

ON-state saturation voltage: < 1.5 V at 10 mA; < 3.0 V at 100 mA

Protected against false pulse on power-up and continuous overload or short circuit of outputs

Required Overcurrent Protection



WARNING: Electrical connections must be made by qualified personnel in accordance with local and national electrical codes and regulations.

Overcurrent protection is required to be provided by end product application per the supplied table.

Overcurrent protection may be provided with external fusing or via Current Limiting, Class 2 Power Supply.

Supply wiring leads < 24 AWG shall not be spliced.

For additional product support, go to www.bannerengineering.com.

Supply Wiring (AWG)	Required Overcurrent Protection (Amps)
20	5.0
22	3.0
24	2.0
26	1.0
28	0.8
30	0.5

Output Response

2.8 millisecond ON/OFF

Note: 200 millisecond delay on power-up; outputs do not conduct during this time

Adjustments

Five-turn adjustment screw sets cutoff distance between min. and max. positions, clutched at both ends of travel

Repeatability

250 µs

Indicators

2 LED indicators on sensor top:

Green solid: Power on

Amber solid: Light sensed

Amber flashing: Marginal sensing condition

Construction

ABS housing, acrylic lens cover; PVC cable, nickel-plated brass connector, acetal adjustment pot

Environmental Rating

IEC IP67; NEMA 6; UL Type 1

Connections

2 m (6.5 ft) 4-wire PVC cable, 9 m (30 ft) PVC cable, or 4-pin Pico-style or Euro-style 150 mm (6 in) pigtail QD, depending on model

Operating Conditions

Relative Humidity: 95% relative humidity at 50 °C (non-condensing)

Temperature: -20 °C to 55 °C (-4 °F to 131 °F)

Application Notes

For mirror-like objects, minimize the sensor to object mounting distance and tilt the sensor so reflected light is directed away from the sensor when the object is present.

Certifications

