

User Guide

CDE, CDLE Drives

Constant and variable torque
Variable Speed Drives
for induction motors
11kW to 90kW (Europe)
7.5HP to 150HP (USA)



Safety Information

Persons supervising and performing the electrical installation or maintenance of a Drive and/or its external Option Unit must be suitably qualified and competent in these duties. They should be given the opportunity to study and if necessary to discuss this User Guide before work is started.

The voltages present in the Drive and external Option Units are capable of inflicting a severe electric shock and may be lethal. The Stop function of the Drive does not remove dangerous voltages from the terminals of the Drive and external Option Unit. Mains supplies should be removed before any servicing work is performed.

The installation instructions should be adhered to. Any questions or doubt should be referred to the supplier of the equipment. It is the responsibility of the owner or user to ensure that the installation of the Drive and external Option Unit, and the way in which they are operated and maintained complies with the requirements of the Health and Safety at Work Act in the United Kingdom and applicable legislation and regulations and codes of practice in the UK or elsewhere.

The Drive software may incorporate an optional Auto-start facility. In order to prevent the risk of injury to personnel working on or near the motor or its driven equipment and to prevent potential damage to equipment, users and operators, all necessary precautions must be taken if operating the Drive in this mode.

The Stop and Start inputs of the Drive should not be relied upon to ensure safety of personnel. If a safety hazard could exist from unexpected starting of the Drive, an interlock should be installed to prevent the motor being inadvertently started.

General Information

The manufacturer accepts no liability for any consequences resulting from inappropriate, negligent or incorrect installation or adjustment of the optional operating parameters of the equipment or from mismatching the Drive with the motor.

The contents of this User Guide are believed to be correct at the time of printing. In the interests of a commitment to a policy of continuous development and improvement, the manufacturer reserves the right to change the specification of the product or its performance, or the contents of the User Guide, without notice.

All rights reserved. No part of this User Guide may be reproduced or transmitted in any form or by any means, electrical or mechanical including photocopying, recording or by any information storage or retrieval system, without permission in writing from the publisher.

Copyright © July 1995

Control Techniques Drives Ltd

Part Number: 0427-0006

Issue Code: CELU5

Issue Date: July 1995

S/W Version:

Machine Control V02.00.00

User Interface V02.xx.xx

Contents

1	Description	1-1	4	Electrical Installation	4-1
1.2	How best to use this User Guide	1-1	4.1	Cables	4-1
2	Data	2-1	4.2	Grounding	4-1
2.1	Model range	2-1	4.3	Grounding terminals	4-1
2.2	Industrial and HVAC applications	2-1	4.4	Power connections	4-2
2.3	Ingress protection (IP and NEMA 1)	2-1	4.5	DC bus choke	4-2
2.4	AC supply	2-1	4.6	External braking resistor	4-2
2.5	Drive output	2-1	4.7	Control Keypad connections	4-2
2.6	Ambient temperature and humidity	2-1	4.8	Signal connections	4-3
2.7	Derating	2-1	5	Setting Jumpers	5-1
2.8	Starts per hour	2-1	6	Control Keypad	6-1
2.9	PWM switching frequencies	2-2	6.1	Display	6-1
2.10	Vibration	2-2	6.2	Keypad	6-2
2.11	Serial communications	2-2	6.3	Status indicators	6-2
2.12	Electromagnetic compatibility (EMC)	2-2	6.4	Displays in Status Mode	6-3
2.13	Frequency accuracy	2-2	6.5	Display in the event of a Trip	6-3
2.14	Weights	2-2	7	Programming Instructions	7-1
2.15	Circuit-breaker	2-2	7.1	Menu structure	7-1
2.16	Fuse ratings	2-2	7.2	Types of parameters	7-1
2.17	DC bus choke ratings	2-3	7.3	Select a parameter for display (Parameter mode)	7-1
2.18	Power ratings	2-4	7.4	Edit a parameter value (Edit mode)	7-2
2.19	Losses and efficiency	2-7	7.5	Maximum and minimum values	7-2
3	Mechanical Installation	3-1	7.6	Restore all parameters to their default values	7-3
3.1	Hazardous areas	3-1	7.7	Save edited parameter values	7-3
3.2	Mounting location	3-1	7.8	Reset the Drive	7-3
3.3	Control Keypad	3-1	8	Getting Started	8-1
3.4	Mounting the DC bus choke	3-2	8.1	Motor ratings	8-1
3.5	Installing in a sealed enclosure	3-3	8.2	Operating in Terminal Mode	8-1
3.6	Installing in a ventilated enclosure	3-4	8.3	Operating in Keypad Mode	8-2
3.7	Mounting a DC braking resistor	3-4	9	Trip codes	9-1
3.8	Motor cooling	3-4	10	Security	10-1
			10.1	Unlocking Standard Security	10-1
			10.2	Unlocking User Security	10-1
			10.3	Setting-up User Security	10-2
			10.4	Locking Security	10-2

11	List of Parameters	11-1	12	Serial Communications	12-1
11.1	Values and character strings	11-1	12.1	Introduction	12-1
11.2	Parameter XX.00	11-1	12.2	Connecting the Drive	12-1
11.3	List of menus	11-1	12.3	Message structure	12-1
11.4	Codes used in the parameter lists	11-1	12.4	Interrogate the Drive	12-3
11.5	Menu 0 — User Menu	11-2	12.5	Send a command to the Drive	12-3
11.6	Menu 1 — Frequency reference, limits and filters	11-4	12.6	Change a parameter value	12-3
11.7	Menu 2 — Ramps	11-8	12.7	Control the Drive	12-3
11.8	Menu 3 — Frequency input and output	11-12	12.8	Messages from Drive to host	12-4
11.9	Menu 4 — Current limits and torque control	11-16	12.9	Reply to an interrogation	12-4
11.10	Menu 5 — Motor control	11-20	12.10	Acknowledge a command	12-4
11.11	Menu 6 — Operational modes	11-24	12.11	Other messages from host to Drive	12-4
11.12	Menu 7 — Analog inputs and outputs	11-30	12.12	Summary of Serial Communications messages	12-4
11.13	Menu 8 — Programmable digital inputs	11-34	Control Techniques Worldwide Drive Centres and Distributors		
11.14	Menu 9 — Programmable digital outputs	11-36			
11.15	Menu 10 — Status logic and diagnostic information	11-39			
11.16	Menu 11 — Miscellaneous parameters	11-42			
11.17	Menu 12 — Programmable thresholds	11-44			
11.18	Menu 13 — Timer functions	11-45			
11.19	Menu 14 — PID control loop, Encoder feedback	11-46			

1 Description

Controlling the Drive

Operation of the Drive is controlled by programming a number of software parameters. These parameters have default values that enable the Drive to be run without initial programming. A diagram of the basic structure of the control system is shown in Figure 1-1 below. (Refer to Chapter 11 *List of Parameters* for details of the parameters.)

The Drive has two display panels and an eight-key keypad which is located on the front panel of the case. The display and keypad are used for the following:

- Change parameter values
- Stop and start the Drive
- Display the operating status of the Drive

1.2 How best to use this User Guide

This User Guide is arranged logically: reading from beginning to end will take you in the correct order through the basic steps of installing the Drive and getting it running with a motor.

To make subsequent adjustments to the parameters, refer to Chapter 11 *List of Parameters*.

The Table of Contents is organised in a simple way to help guide you quickly to the required section.

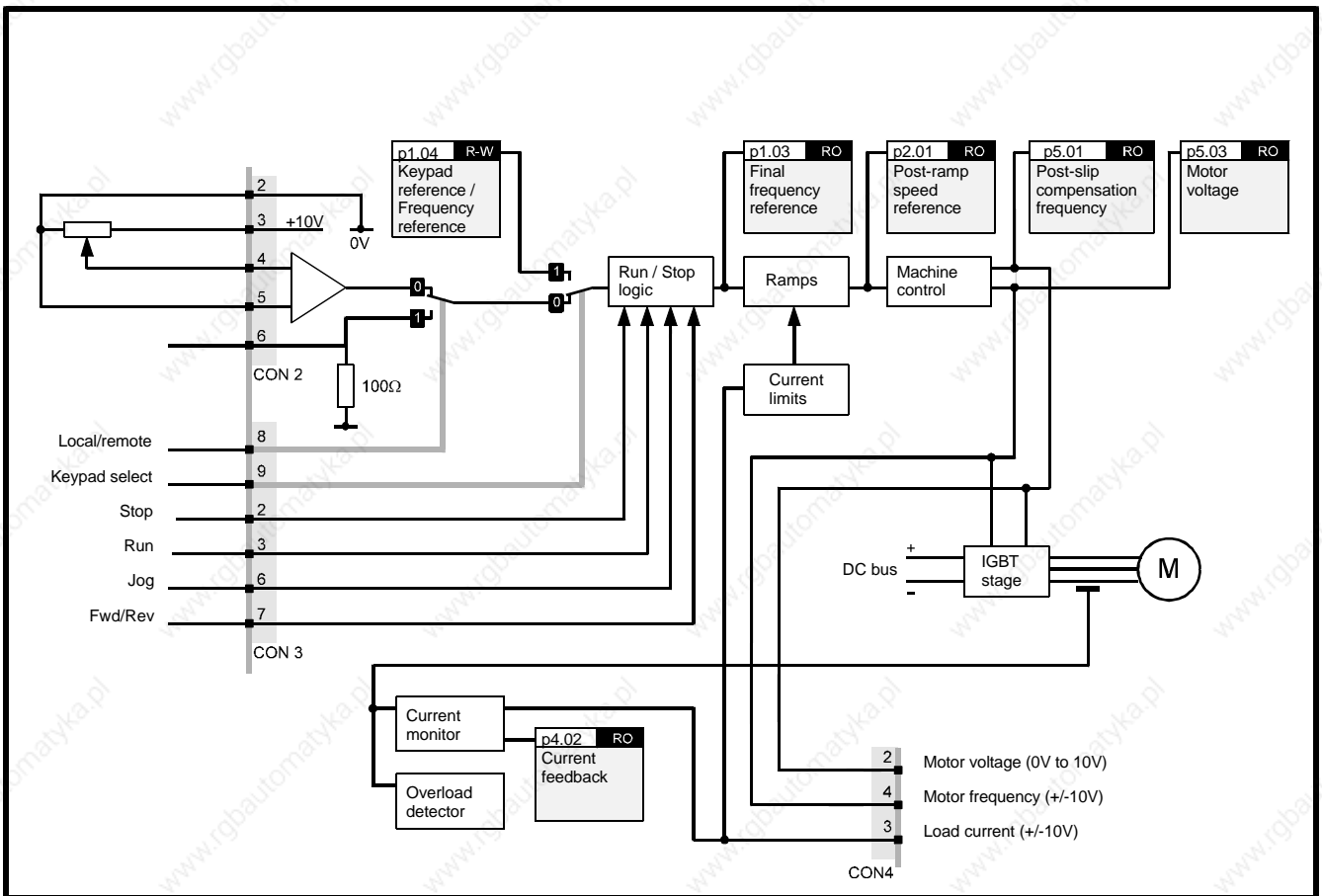

Figure 1-1 Basic structure of the control system

2 Data

2.1 Model range

European models

Nine models in two model sizes cover the power ratings for European applications as follows:

Model size	AC supply	Model code	Power ratings	
			IND	HVAC
1	Normal voltage	CDE1100	11 kW	15 kW
		CDE1500	15 kW	18.5 kW
		CDE1850	18.5 kW	22 kW
		CDE2200	22 kW	30 kW
		CDE3000	30 kW	37 kW
2	Normal voltage	CDE3700	37 kW	45 kW
		CDE4500	45 kW	55 kW
		CDE5500	55 kW	75 kW
		CDE7500	75 kW	90 kW

North American models

Eighteen models in two model sizes and two AC supply voltages cover the power ratings for North American applications as follows:

Model size	AC supply	Model code	Power ratings	
			IND	HVAC
1	Normal voltage	CDE15HP	15 HP	20 HP
		CDE20HP	20 HP	25 HP
		CDE25HP	25 HP	30 HP
		CDE30HP	30 HP	40 HP
		CDE40HP	40 HP	50 HP
	Low voltage	CDLE7.5HP	7.5 HP	10 HP
		CDLE10HP	10 HP	15 HP
		CDLE15HP	15 HP	20 HP
		CDLE20HP	20 HP	25 HP
2	Normal voltage	CDE50HP	50 HP	60 HP
		CDE60HP	60 HP	75 HP
		CDE75HP	75 HP	100 HP
		CDE125HP	125 HP	150 HP
	Low voltage	CDLE25HP	25 HP	30 HP
		CDLE30HP	30 HP	45 HP
		CDLE40HP	40 HP	50 HP
		CDLE50HP	50 HP	60 HP
		CDLE60HP	60 HP	

Note

When a model is used for HVAC applications, its power rating becomes equal to the industrial power rating of the next larger model size. (The overload current remains the same.)

2.2 Industrial and HVAC applications

All models can be programmed by the user for industrial or HVAC applications.

2.3 Ingress protection (IP and NEMA 1)

European models

IP00 (in accordance with the IEC529)

North American models

NEMA 1

Cooling fans

IP20

2.4 AC supply

Balanced 3-phase

50Hz \pm 2Hz or 60Hz \pm 2Hz

CDE: 380V -10% to 480V $+10\%$

CDLE: 200V -10% to 240V $+10\%$

2.5 Drive output

Maximum frequency: 1kHz

Maximum output voltage:

Equal to the AC supply voltage

2.6 Ambient temperature and humidity

Ambient temperature range:

-10°C to $+50^{\circ}\text{C}$ (14°F to 122°F) non-condensing.

Local heat sources (such as other equipment) that raise the air temperature above $+50^{\circ}\text{C}$ (122°F) must be removed.

2.7 Derating

Derate full load current by 1% for each additional 100m (320ft) above 1000m (3200ft).

2.8 Starts per hour

Drive: 20 per hour

Motor: Refer to the motor manufacturer

2.9 PWM switching frequencies

Case size 1 – 3kHz or 6kHz

Case size 2 – 3kHz

2.10 Vibration

Conformance to the requirements of IEC 68–2–34

2.11 Serial communications

RS485 full duplex (RS422 can also be used)

Protocol: ANSI x 3.28–2.5–A4–N, positive logic

Timing

Write to the Drive:

25ms at 9600 Baud

15ms at 19.2 kBaud

Read from the Drive:

30ms at 9600 Baud

16ms at 19.2 kBaud

2.12 Electromagnetic compatibility (EMC)

Conducted emissions

Conducted emission requirements of EN50081–2 are met when an optional RFI filter is used. Refer to the supplier of the Drive for information on suitable filters and installation requirements.

Immunity

In accordance with IEC801 without significant disturbance to operation at the following level:

Part 4 (Transient Burst) Level 4

2.13 Frequency accuracy

Output frequency is within ± 100 ppm of the frequency demand.

2.14 Weights

The maximum weight for each case size is as follows:

European case size 1: 22.3kg (49lb)

European case size 2: 56kg (123lb)

USA NEMA size 1: 36kg (81lb)

USA NEMA size 2: 90kg (201lb)

2.15 Circuit-breaker

Use a circuit-breaker having characteristic **type K**.

2.16 Fuse ratings

Fuses must satisfy the following:

IEC269 Parts 1 and 2, type **gI** characteristic

BS88 Parts 1 and 2, HRC fuses

An MCB or MCCB may be used instead of fuses if it is equipped with adjustable thermal and magnetic trips.

Fuse ratings for European models

Recommended fuse ratings for AC supply = 400V

Model	Fuse rating	
	Industrial applications A	HVAC applications A
CDE1100	35	40
CDE1500	40	50
CDE1850	50	60
CDE2200	60	70
CDE3000	70	80
CDE3700	80	100
CDE4500	100	125
CDE5500	125	160
CDE7500	160	200

Fuse ratings for North American models

Recommended fuse ratings for AC supply = 480V

Model	Fuse rating	
	Industrial applications A	HVAC applications A
CDE15HP	30	35
CDE20HP	35	40
CDE25HP	40	50
CDE30HP	50	60
CDE40HP	60	75
CDE50HP	75	80
CDE60HP	80	100
CDE75HP	100	140
CDE100HP	140	160
CDE125HP	160	200

Recommended fuse ratings for AC supply = 240V

Model	Fuse rating	
	Industrial applications A	HVAC applications A
CDLE7.5HP	30	35
CDLE10HP	35	50
CDLE15HP	50	60
CDLE20HP	60	80
CDLE25HP	80	90
CDLE30HP	90	125
CDLE40HP	125	140
CDLE50HP	140	160

2.17 DC bus choke ratings

Ripple frequency = 6 × supply frequency

Ratings and values quoted are design minima

Value mH	Current ratings		Weight	
	ARMS	Apk	kg	lb
1.35	39	72	4.5	10
1.50	45	85	6.4	14
0.65	60	128	5.4	12
0.70	75	143	8.4	19
0.80	89	167	16.5	36
0.45	111	224	14.5	32
0.50	130	251	22.5	50
0.40	176	352	32.0	71
0.30	212	350	35.0	77

Application table

Choke value mH	Application		
	European models	North American models	North American Low voltage models
1.35	CDE1100	CDE15HP CDE20HP	CDLE7.5HP
1.50	CDE1500	CDE25HP	
0.65	CDE1850		CDLE10HP
0.70	CDE2200	CDE30HP	CDLE15HP
0.80	CDE3000	CDE40HP	CDLE20HP
0.45	CDE3700	CDE50HP	CDLE25HP
0.50	CDE4500	CDE60HP	CDLE30HP
0.40	CDE5500	CDE75HP	CDLE40HP
0.30	CDE7500	CDE100HP CDE125HP	CDLE50HP CDLE60HP

2.18 Power ratings

Note

The displacement factor (fundamental power factor) presented to the AC supply closely approximates to unity, but is dependent on the AC supply impedance.

CDE 11kW to 90kW – European models

Power ratings are for typical 3-phase 4-pole motors.

Nominal supply voltage: 400V RMS

IND: Industrial application capable of 150% overload for 60 seconds.

HVAC: Fan and pump applications capable of 120% overload for 60 seconds.

Model size	Model	Output ratings				AC supply			
			Motor rating kW	100% RMS current A	Current overload %	100% RMS current A	100% complex power kVA	100% fundamental current A	100% real power kW
1	CDE1100	IND	11	25	150	27	17	22	15
		HVAC	15	32	120	32	21	28	19
	CDE1500	IND	15	32	150	32	21	28	19
		HVAC	18.5	38	120	35	23	32	21
	CDE1850	IND	18.5	38	150	37	24	33	22
		HVAC	22	46	120	49	32	41	27
	CDE2200	IND	22	46	150	49	32	41	27
		HVAC	30	62	120	61	40	55	36
CDE3000	IND	30	59	150	58	38	51	34	
	HVAC	37	70	120	68	45	62	41	
2	CDE3700	IND	37	76	150	77	48	67	44
		HVAC	45	91	120	91	60	80	52
	CDE4500	IND	45	91	150	90	59	79	52
		HVAC	55	110	120	106	70	97	64
	CDE5500	IND	55	110	150	106	70	97	64
		HVAC	75	144	120	139	91	127	84
	CDE7500	IND	75	150	150	144	95	133	87
		HVAC	90	180	120	173	114	158	106

CDE 15HP to 150HP – North American models

Power ratings are for standard NEMA motors

Nominal voltage: 440V to 480VRMS

IND: Industrial application capable of 150% overload for 60 seconds.

HVAC: Fan and pump applications capable of 120% overload for 60 seconds.

Model size	Model	Output ratings				AC supply			
			Motor rating HP	100% RMS current A	Current overload %	100% RMS current A	100% complex power kVA	100% fundamental current A	100% real power kW
1	CDE15HP	IND	15	21	120	21	18	19	16
		HVAC	20	27	150	27	22	24	20
	CDE20HP	IND	20	27	120	27	22	24	20
		HVAC	25	34	150	34	28	30	25
	CDE25HP	IND	25	34	120	32	27	29	24
		HVAC	30	40	150	37	29	34	27
	CDE30HP	IND	30	40	120	37	29	34	27
		HVAC	40	52	150	51	42	45	37
CDE40HP	IND	40	52	120	51	42	45	37	
	HVAC	50	65	150	63	52	57	48	
2	CDE50HP	IND	50	65	120	65	54	57	48
		HVAC	60	77	150	77	64	68	56
	CDE60HP	IND	60	77	120	77	64	68	56
		HVAC	75	96	150	96	80	84	70
	CDE75HP	IND	75	96	120	93	77	85	70
		HVAC	100	124	150	119	99	109	91
	CDE100HP	IND	100	124	120	119	99	108	90
		HVAC	125	156	150	150	125	137	114
CDE125HP	IND	125	156	120	150	125	137	114	
	HVAC	150	180	150	173	144	157	131	

CDLE 7.5HP to 60HP – North American models

Power ratings are for standard NEMA motors
Nominal voltage: 200V to 240VRMS

IND: Industrial application capable of 150%
overload for 60 seconds.

HVAC: Fan and pump applications capable of
120% overload for 60 seconds.

Model size	Model	Output ratings				AC supply			
			Motor rating HP	100% RMS current A	Current overload %	100% RMS current A	100% complex power kVA	100% fundamental current A	100% real power kW
1	CDLE7.5HP	IND	7.5	22	120	22	9	19	8
		HVAC	10	28	150	28	12	25	10
	CDLE10HP	IND	10	28	120	28	12	25	10
		HVAC	15	42	150	45	19	37	15
	CDLE15HP	IND	15	42	120	42	17	37	15
		HVAC	20	54	150	53	22	47	20
CDLE20HP	IND	20	54	120	53	22	47	20	
	HVAC	25	68	150	68	28	62	26	
2	CDLE25HP	IND	25	68	120	66	27	58	24
		HVAC	30	80	150	80	33	70	29
	CDLE30HP	IND	30	80	120	77	32	70	29
		HVAC	40	104	150	100	42	91	38
	CDLE40HP	IND	40	104	120	100	42	91	38
		HVAC	50	130	150	125	52	115	48
	CDLE50HP	IND	50	130	120	125	52	114	47
		HVAC	60	145	150	139	58	129	53
	CDLE60HP	IND	60	145	120	140	58	127	53
		No HVAC ratings							

2.19 Losses and efficiency

Note

Figures quoted are at 100% output power.

CDE 11kW to 90kW – European models

Model size	Model		Total power loss		Efficiency (AC supply = 380V)		Efficiency (AC supply = 480V)		
			3kHz W	6kHz W	3kHz %	6kHz %	3kHz %	6kHz %	
1	CDE1100	IND	358	440	97.6	97.1	98.0	97.6	
		HVAC	442	544	97.7	97.2	98.1	97.6	
	CDE1500	IND	404	498	97.7	97.1	98.1	97.6	
		HVAC	491	606	97.7	97.2	98.1	97.7	
	CDE1850	IND	490	615	97.8	97.3	98.2	97.7	
		HVAC	593	742	97.8	97.3	98.2	97.8	
	CDE2200	IND	572	724	97.9	97.4	98.3	97.8	
		HVAC	761	961	97.9	97.4	98.3	97.8	
	CDE3000	IND	698	886	98.0	97.4	98.3	97.9	
		HVAC	834	1068	98.0	97.4	98.3	97.9	
	2	CDE3700	IND	934		97.9		98.3	
			HVAC	1124		97.9		98.3	
CDE4500		IND	1106		97.9		98.3		
		HVAC	1357		97.9		98.3		
CDE5500		IND	1322		98.0		98.3		
		HVAC	1774		97.9		98.2		
CDE7500		IND	1897		97.9		98.2		
		HVAC	2323		97.8		98.2		

CDE 15HP to 150HP – North American models

Model size	Model		Total power loss		Efficiency (AC supply = 480V)	
			3kHz W	6kHz W	3kHz %	6kHz %
1	CDE15HP	IND	300	370	98.0	97.6
		HVAC	373	459	98.1	97.6
	CDE20HP	IND	352	434	98.1	97.6
		HVAC	439	542	98.1	97.7
	CDE25HP	IND	438	550	98.2	97.7
		HVAC	490	613	98.2	97.8
	CDE30HP	IND	475	498	98.3	97.8
		HVAC	638	806	98.3	97.8
CDE40HP	IND	615	781	98.3	97.9	
	HVAC	744	992	98.3	97.9	
2	CDE50HP	IND	799		98.3	
		HVAC	951		98.3	
	CDE60HP	IND	936		98.3	
		HVAC	1148		98.3	
	CDE75HP	IND	1153		98.3	
		HVAC	1528		98.2	
	CDE100HP	IND	1568		98.2	
		HVAC	2013		98.2	
CDE125HP	IND	1973		98.2		
	HVAC	2323		98.2		

CDLE 7.5HP to 60HP – North American models

Model size	Model		Total power loss		Efficiency (AC supply = 240V)	
			3kHz W	6kHz W	3kHz %	6kHz %
1	CDLE7.5HP	IND	303	374	96.2	95.3
		HVAC	386	476	96.1	95.2
	CDLE10HP	IND	386	476	96.1	95.2
		HVAC	541	677	96.4	95.5
	CDLE15HP	IND	564	651	96.2	95.7
		HVAC	663	837	96.7	95.8
	CDLE20HP	IND	663	837	96.7	95.8
		HVAC	810	1037	96.9	96.0
2	CDLE25HP	IND	840		96.5	
		HVAC	988		96.6	
	CDLE30HP	IND	987		96.6	
		HVAC	1253		96.6	
	CDLE40HP	IND	1283		96.6	
		HVAC	1601		96.6	
	CDLE50HP	IND	1677		96.4	
		HVAC	1786		96.6	
	CDLE60HP	IND	1871		96.5	
		No HVAC ratings				

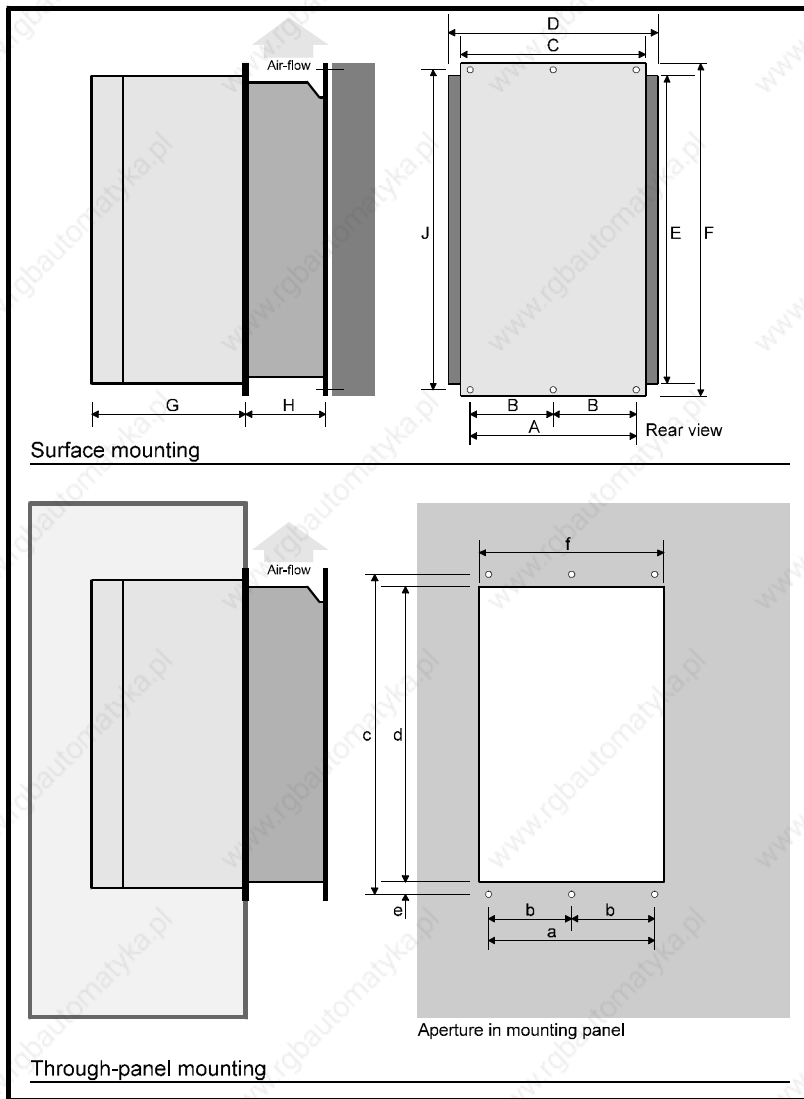

Figure 2-1 Dimensions of the Drive

Dimensions of the Drive

Dimension	Case size			
	1		2	
	mm	in	mm	in
A	248.0	9 ⁵ / ₈	360.0	14 ³ / ₁₆
B			180.0	7 ¹ / ₁₆
C	295.2	11 ⁵ / ₈	464.5	18 ¹ / ₄
D	330.0	13	490.0	19 ⁵ / ₁₆
E	490.0	19 ⁵ / ₁₆	795.0	31 ⁵ / ₁₆
F	522.2	20 ⁹ / ₁₆	843.5	33 ³ / ₁₆
G	145.0	5 ¹¹ / ₁₆	170.0	6 ¹¹ / ₁₆
H	138.4	5 ⁷ / ₁₆	135.0	5 ⁵ / ₁₆
J	490.0	19 ⁵ / ₁₆	798.0	31 ⁷ / ₁₆
Mounting screws	M6	1/4 (clear)	M8	5/16 (clear)

Mounting hole dimensions

Dimension	Case size			
	1		2	
	mm	in	mm	in
a	249.0	9 ¹³ / ₁₆	360.0	14 ³ / ₁₆
b			180.0	7 ¹ / ₁₆
c	502.0	19 ³ / ₄	815.0	32 ¹ / ₁₆
d	466.0	18 ⁵ / ₁₆	780.0	30 ¹¹ / ₁₆
e	21.0	13/16	25.0	1
f	296.0	11 ⁵ / ₈	467.0	18 ³ / ₈

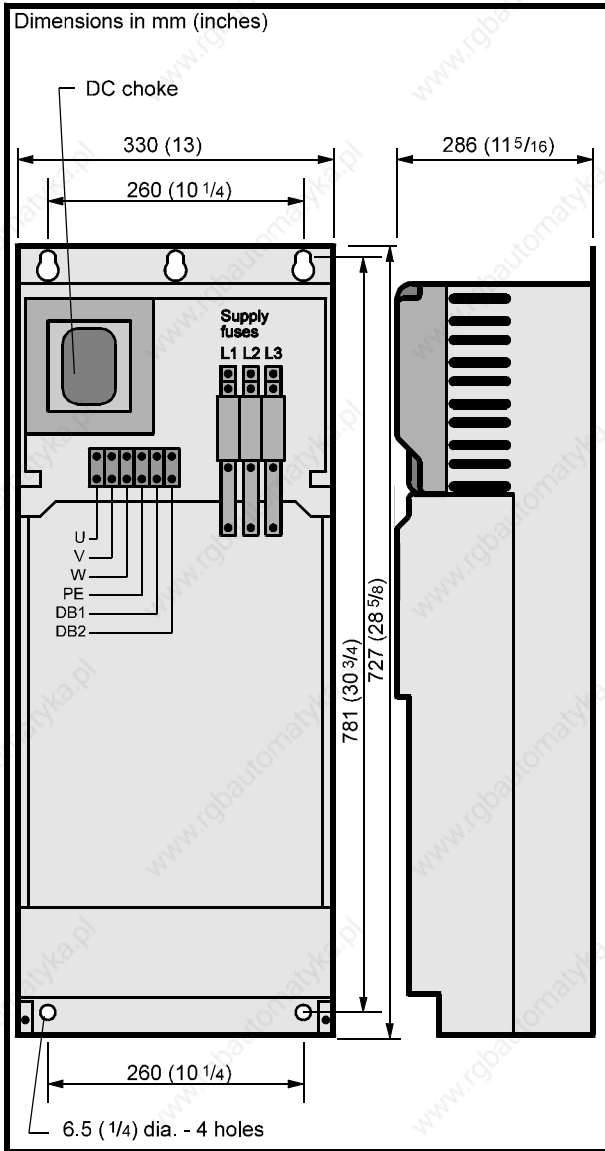

All terminals are compression type.
Cable entry is at the top of the case.

Figure 2-2 NEMA 1 case — Case size 1

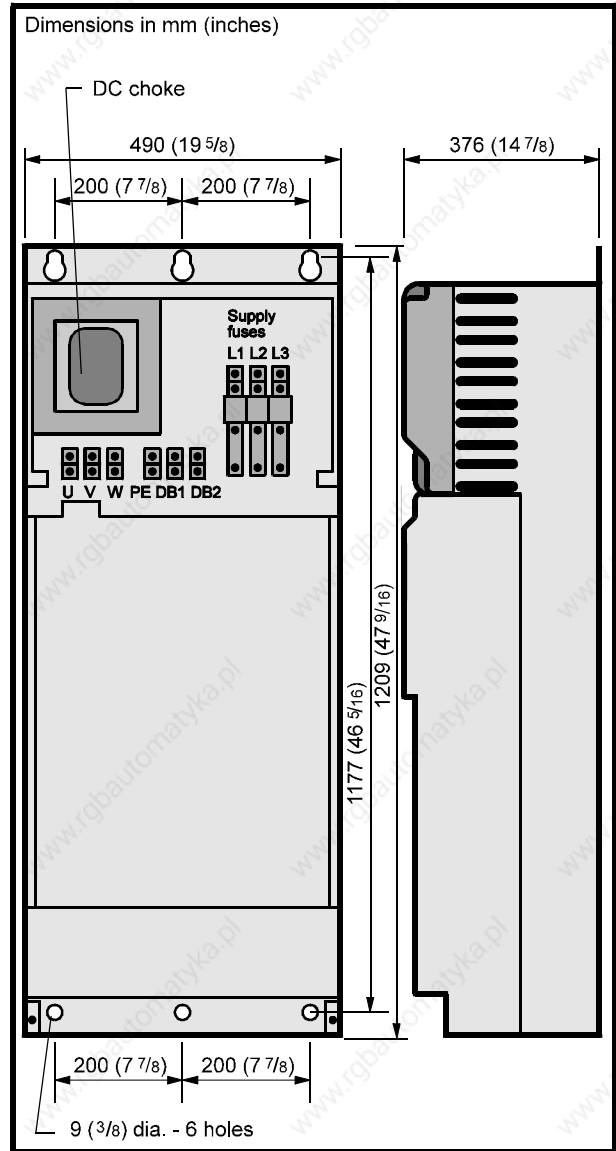

All terminals are compression type.
Cable entry is at the top of the case.

Figure 2-3 NEMA 1 case — Case size 2

3 Mechanical Installation

3.1 Hazardous areas

The application of variable speed drives may invalidate the hazardous area certification (Apparatus Group and Temperature Class) of squirrel cage induction motors. Approval and certification should be obtained for the complete installation of motor and Drive.

3.2 Mounting location

1. Choose a location that is free from excessive dust, corrosive vapours, gases and all liquids, including condensation of atmospheric moisture.
2. If condensation is likely to occur when the Drive is not in use, install an anti-condensation heater. This heater must be switched off when the Drive is in use; automatic switching is recommended.
3. Do not locate the Drive in a classified hazardous area, unless the Drive is installed in an approved enclosure and the installation is certified.
4. Install the Drive vertically for best flow of cooling air.
5. Observe the requirements for ambient temperature if the Drive is to be mounted directly above any heat generating equipment (such as another Drive). The Drive has over-temperature protection which trips the Drive when the heatsink reaches 90°C (194°F).
6. If the Drive is to be installed directly beneath other equipment (such as another variable speed Drive), ensure the Drive does not cause the ambient temperature requirements of the equipment to be exceeded.
7. Leave a minimum clearance of 100mm (4in) above and below the Drive when mounting it close to other equipment.
8. If the Drive is not supplied in a NEMA 1 case and when ingress protection higher than IP00 (IEC529) is required, install the Drive in an enclosure and ensure its location and means of access conform to UK or appropriate safety regulations. The Drive can be surface mounted or through-panel mounted in a sealed or ventilated enclosure.

3.3 Control Keypad

The Control Keypad is a plug-in unit which can be detached from the Drive for mounting in a panel. Holes are required in the panel for the fixing studs and connector which project from the rear of the Control Keypad housing. Refer to Figure 3–1.

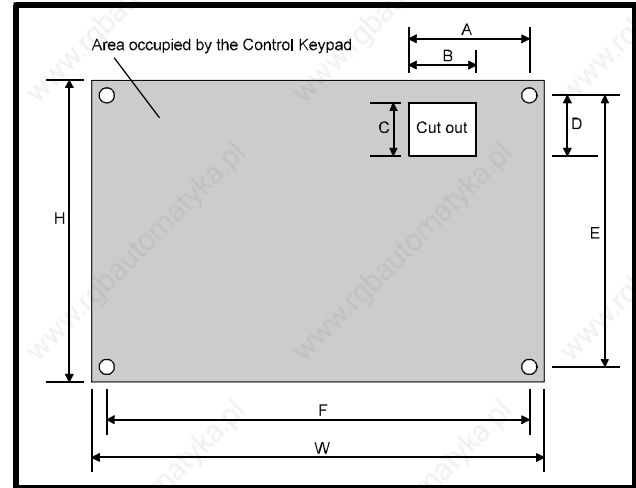

Dim.	mm	in
A	65.0	2 ⁹ / ₁₆
B	40.0	1 ⁹ / ₁₆
C	26.0	1 ¹ / ₁₆
D	22.0	7/ ₈
E	97.0	3 ¹³ / ₁₆
F	146.5	5 ³ / ₄
H	167	6 ⁹ / ₁₆
W	114	4 ¹ / ₂
Hole dia.	M4	3/ ₁₆

Figure 3–1 Mounting screw holes and dimensions of cut-out required for remote mounting of the Control Keypad

3.4 Mounting the DC bus choke

A choke (inductor) is required for the DC bus.

For Drives in an IP00 case, the DC bus choke is installed externally to the Drive. For Drives in a NEMA 1 case, the DC bus choke is installed internally.

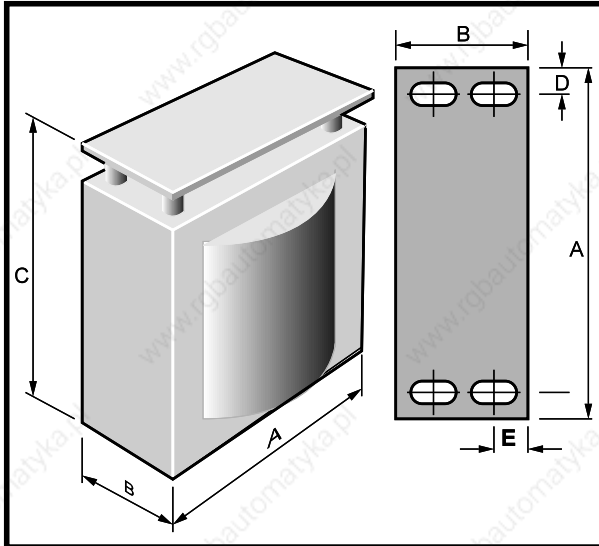

Figure 3-2 Dimensions of the DC bus choke

Choke value mH	A		B		C		D		E		Terminal size	Weight	
	mm	in.	mm	in.	mm	in.	mm	in.	mm	in.		kg	lb
1.35	118	4 ⁵ / ₈	82	3 ¹ / ₄	155	6 ¹ / ₈	27	1 ¹ / ₁₆	7	1 ¹ / ₄	M8	4.5	10
1.50	137	5 ⁷ / ₁₆	84	3 ⁵ / ₁₆	175	6 ⁷ / ₈	24	1 ⁵ / ₁₆	10	3 ³ / ₈	M8	6.4	14
0.65	118	4 ⁵ / ₈	95	3 ³ / ₄	155	6 ¹ / ₈	27	1 ¹ / ₁₆	7	1 ¹ / ₄	M8	5.4	12
0.70	137	5 ⁷ / ₁₆	116	4 ⁹ / ₁₆	175	6 ⁷ / ₈	24	1 ⁵ / ₁₆	10	3 ³ / ₈	M8	8.4	19
0.80	167	6 ⁵ / ₈	132	5 ³ / ₁₆	200	7 ⁷ / ₈	39	1 ⁹ / ₁₆	8	5 ⁵ / ₁₆	M8	16.5	36
0.65	167	6 ⁵ / ₈	119	4 ¹¹ / ₁₆	197	7 ³ / ₄	39	1 ⁹ / ₁₆	8	5 ⁵ / ₁₆	M8	14.5	32
0.50	195	7 ¹¹ / ₁₆	138	5 ⁷ / ₁₆	230	9 ¹ / ₁₆	46	1 ¹³ / ₁₆	11	7 ⁷ / ₁₆	M10	22.5	50
0.40	215	8 ⁷ / ₁₆	166	6 ⁹ / ₁₆	254	10	51	2 ¹² / ₁₆	13	1 ¹ / ₂	M10	32.0	71
0.30	215	8 ⁷ / ₁₆	177	6 ¹⁵ / ₁₆	254	10	51	2 ¹² / ₁₆	13	1 ¹ / ₂	M10	35.0	77

3.5 Installing in a sealed enclosure

To maintain sufficient cooling of the Drive when it is installed inside a sealed enclosure, heat generated by all the equipment in the enclosure must be taken into account and the enclosure must be of adequate size. To calculate the minimum acceptable size of enclosure, use the following procedure.

Calculate the minimum required surface area A_e for the enclosure from:

$$A_e = \frac{P}{k(T_i - T_{amb})}$$

where:

A_e = Unobstructed heat-conducting area in m^2

k = Heat Transmission coefficient of the enclosure material in $Watts/m^2/^\circ C$

T_i = Maximum permissible operating temperature in $^\circ C$ of the Drive

T_{amb} = Maximum external ambient temperature in $^\circ C$

P = Power in Watts dissipated by all heat sources in the enclosure

Example

To calculate the size of an enclosure for one CDE 1100 Drive. The following conditions are assumed:

The installation is to conform to IP54, requiring the CDE Drive to be surface-mounted within a sealed enclosure.

Only the top, front and two sides of the enclosure are free to dissipate heat.

The enclosure is made of painted 2mm ($3/32$ inch) sheet steel.

Maximum external ambient temperature: $25^\circ C$ ($77^\circ F$).

Drive PWM frequency: 6kHz.

Insert the following values:

P = 440W (from Losses and Efficiency table)

T_i = $50^\circ C$ ($122^\circ F$)

T_{amb} = $25^\circ C$ ($77^\circ F$)

k = 5.5 (typical value for painted 2mm ($1/16$ inch) sheet steel)

The minimum required heat conducting area is then:

$$A_e = \frac{440}{5.5(50 - 25)} = 3.2m^2 (34.5ft^2)$$

The unobstructed heat-conducting area of the enclosure is:

$$A_e = 2HD + HW + DW$$

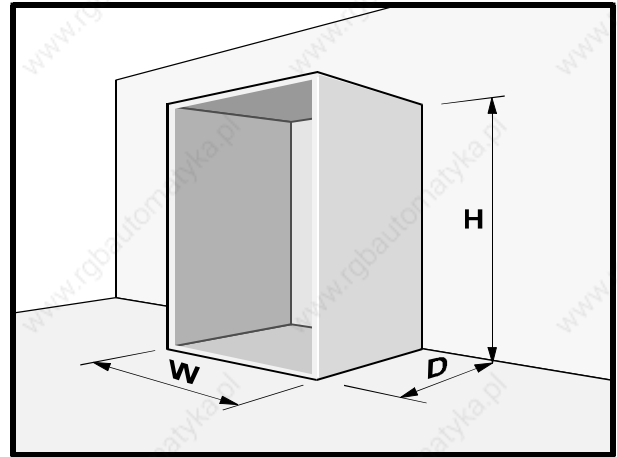

Figure 3-3 Enclosure having top, sides and front surfaces free to dissipate heat

Estimate two of the enclosure dimensions — the height and depth, for instance. Calculate the minimum width from:

$$W = \frac{A_e - 2HD}{H + D}$$

Inserting $H = 1.8$ metres, $D = 0.5$ metre, obtain the minimum width:

$$W = \frac{3.2 - (2 \times 1.8 \times 0.5)}{1.8 + 0.5} = 0.6 \text{ metres approx}$$

If possible, locate heat-generating equipment in the lower part of the enclosure to encourage internal convection. Otherwise, increase the height of the enclosure or install 'stirrer' fans.

3.6 Installing in a ventilated enclosure

If a high ingress factor is not required, a ventilated enclosure may be used. This will be smaller than a sealed enclosure.

To calculate the minimum required volume of ventilating air, use the following formula:

$$V = \frac{3.1 \times P}{T_i - T_{amb}}$$

where:

V = Air-flow in m³/hr

P = Power in Watts dissipated by all heat sources in the enclosure

T_i = Maximum permissible operating temperature in °C of the Drive

T_{amb} = Maximum external ambient temperature in °C

Example

To calculate the ventilation requirement for one CDE1100 Drive:

P = 440W

T_i = 50°C

T_{amb} = 25°C

Then..

$$V = \frac{3.1 \times 440}{50 - 25} = 55m^3 / hr = 1947ft^3 / hr$$

3.7 Mounting a DC braking resistor

Refer to the manufacturer's instructions for mounting the DC braking resistor.

Mount the resistor as close as possible to the Drive, but not in a position where air heated by it could affect the Drive.

For Drives in an IP00 case, the DC braking resistor should be installed externally to the Drive. For Drives in a NEMA 1 case, the DC braking resistor should be installed internally.

3.8 Motor cooling

When a motor is driven at low speed, its internal cooling fan becomes less effective. If necessary, provide it with additional cooling (such as forced ventilation).

4 Electrical Installation

Warning

Electric shock risk

The voltages present in the following locations can cause severe electric shock and may be lethal:

- Supply cables
- Output cables
- Terminals
- DC bus choke
- Braking circuit
- Certain parts of the Drive

If the Drive has been energized, the AC supply must be isolated at least seven minutes before work may continue. Refer to Safety Information on the inside front cover.

4.1 Cables

For the following connections, use 3-core and 4-core pvc-insulated steel-conduit covered cable with copper conductors, laid in accordance with defined conditions:

- AC supply to the Drive
- Drive to motor
- DC bus choke to Drive
- Drive to external braking resistor (if used)

Cable sizes must be selected for 100% of the RMS currents.

This table is only a guide. Refer to local wiring regulations for the correct size of cables.

Full Load Current A	Cable size	
	mm ²	AWG
15	3.3	12
20	4.0	10
30	6.0	8
40	10	6
55 *	16	4
70 *	25	4
115	35	2
130	50	0
150	70	2/0
175	70	2/0
200	95	3/0
230	120	4/0

* For 75°C (167°F) rated cable you may use the next size smaller.

4.2 Grounding

Ground connections must be made in accordance with Figure 4-1. Grounding cables must have at least 50% of the current rating of the supply cables.

Use the shortest possible wiring to connect the Drive to system ground. The system ground must be connected firmly to a ground point that cannot be accidentally disconnected.

The impedance of the ground circuit must conform to the requirements of Health and Safety Regulations that may apply.

Inspect the grounding circuit at appropriate intervals.

Use screened (conduit-covered) cable to the motor. Connect the screen to ground at the power connector on the Drive.

Ground connections on the power input and power output connectors are connected together in the Drive, enabling the following connections to be made through the Drive:

- Motor frame ground to system ground
- Motor frame ground to the machine ground

The Drives are suitable for grounded-delta installation without alteration.

4.3 Grounding terminals

The size of external grounding terminals should be appropriate to the size of the grounding cables.

4.4 Power connections

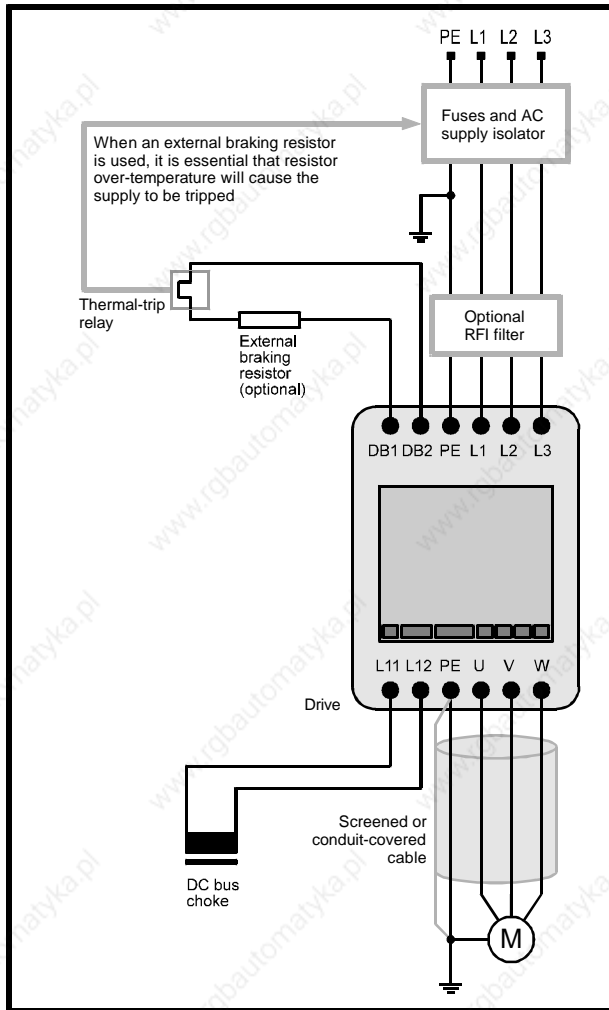

Figure 4-1 Power connections

To gain access to the connectors, remove the four corner screws from the front cover of the Drive and remove the cover.

Make the following connections using the size of cable specified in para 4.1 *Cables*:

- AC power to the Drive
- Drive to the motor
- DC bus choke to the Drive
- External braking resistor to the Drive

The AC power should be applied through an isolator and a fuse or circuit-breaker of the correct rating (see Chapter 2 Data).

Unusually long cable runs between the Drive and the motor may give rise to spurious tripping due to the effect of cable capacitance. As a result, an over-current fault would be indicated (OIAC). In this case, output chokes may be required. In difficult cases, consult the supplier of the Drive.

4.5 DC bus choke

Connect the DC bus choke to terminals **L11** and **L12** of the Drive.

4.6 External braking resistor

When an external braking resistor is used, the isolator must be equipped with an external trip input.

The Drive must be equipped with an optional IN42 Braking Card. Refer to the *IN42 Braking Card User Guide*.

4.7 Control Keypad connections

When the Control Keypad is mounted remotely from the Drive, use screened cable to connect the Control Keypad to the Drive. (A 9-pin D-type connector is used.) Connect the cable screen to an external ground terminal which should be as close to the Control Keypad as possible.

The connecting cable should have a maximum length of 1.8m (6ft).

4.8 Signal connections

Note

The default configuration is shown in the connection diagrams for programmable inputs and outputs.

CON 1 Programmable relays

Relay ratings: 250V 7A AC

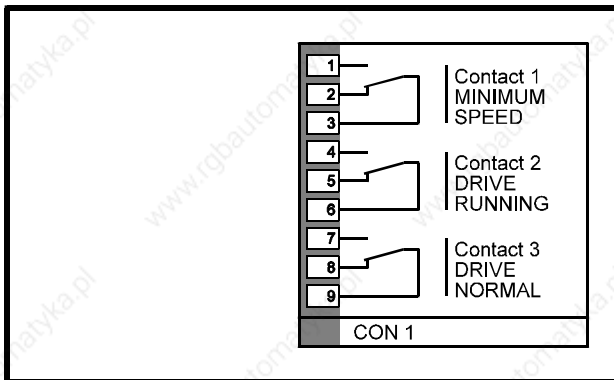

Figure 4-2 Programmable relays

CON 2 Programmable analog inputs

Terminal	CON2
1	-10V reference at 10 mA Internally protected.
2	0V common
3	+10V reference at 10 mA. Internally protected
4 5	Differential input Input options: -10V to +10V 4mA to 20mA (100Ω load) 0 to 20mA (100Ω load) Resolution: 12-bit plus sign, self calibrating
6	Single-ended input (referenced to 0V common) Input options: -10V to +10V 4mA to 20mA (100Ω load) 20mA to 4mA (100Ω load) 0 to 20mA (100Ω load) 20mA to 0 (100Ω load) Resolution: 10-bit plus-sign
7	Single-ended input (referenced to 0V common). Input options: -10V to +10V 4mA to 20 mA (100Ω load) 20mA to 4mA (100Ω load) 0 to 20mA (100Ω load) 20mA to 0 (100Ω load) Open-circuit voltage for use with motor thermal resistor: 2.0VDC Resolution: 10-bit plus-sign

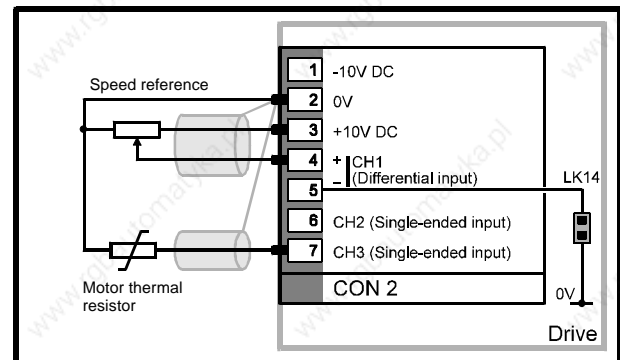

Figure 4-3 Connections to the programmable analog inputs

CON3 Programmable digital inputs

Terminal	Function
1	0V common
2	Stop input signal 0V to +24V, configurable for positive or negative logic
3 to 9	Programmable digital inputs 0V to +24V, configurable for positive or negative logic

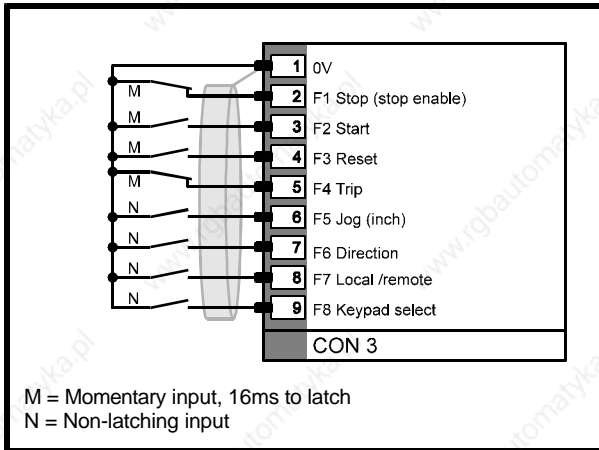

Figure 4-4 Connections to the programmable digital inputs

CON 4 Programmable analog outputs

Terminal	Function
1	0V common
2, 3, 4	-10V to +10V at 10 mA 0 to 20 mA, or 4 to 20 mA, (referenced to 0V common) External load: 0Ω to 500Ω Resolution: 10-bit plus-sign

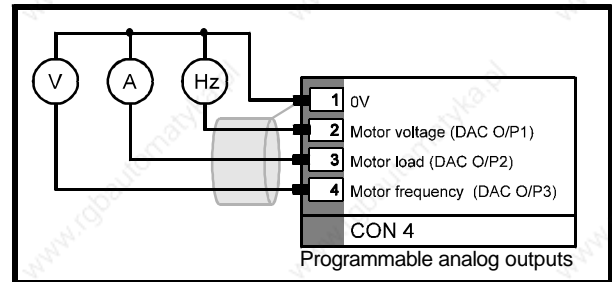

Figure 4-5 Connections to the programmable analog outputs

CON 5 Programmable digital outputs

Terminal	Function-
1	0V common
2	+24V supply at 200mA protected by internal current-trip
3 to 6	0V to +24V output configurable for positive or negative logic Source: 100mA max at +24V Sink: 100mA max at 0V Internal flywheel diodes for driving external relays.

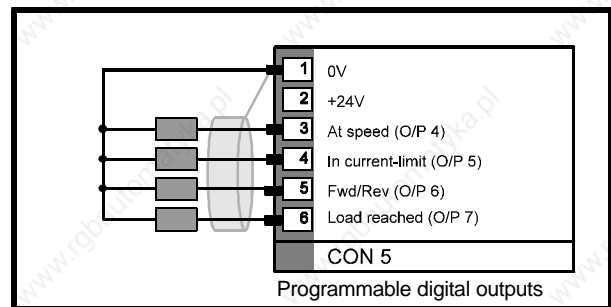

Figure 4-6 Connections to the programmable digital outputs

CON 6
Serial communications

Terminal	Function
1	0V isolated common, referenced to serial comms lines
2	Receive input (inverting)
3	Receive input (non-inverting)
4	Transmit output (inverting)
5	Transmit output (non-inverting)

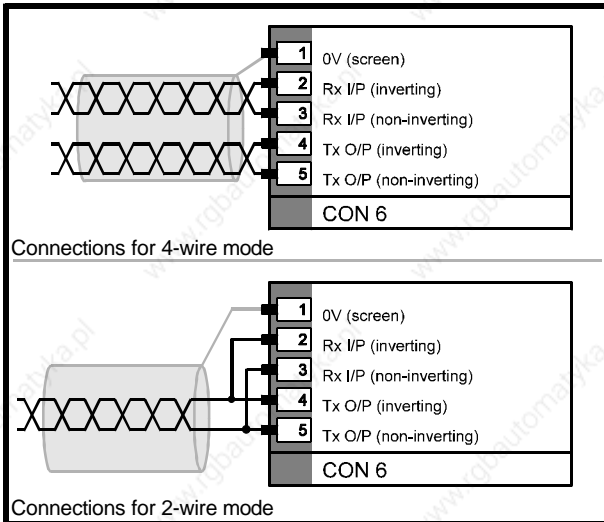

Figure 4-7 Serial communications connections (RS485)

See parameter **p11.26** for selecting 2 wire operation.

CON 7
Frequency input and output / Encoder quadrature input

Terminal	Function
1	0V common
2	Frequency input (non-inverting) or Quadrature input channel A (non-inverting)
3	Frequency input (inverting) or Quadrature input channel A (inverting)
4	Programmable: Frequency output (non-inverting) or Quadrature input channel B (non-inverting)
5	Programmable: Frequency output (inverting) or Quadrature input channel B (inverting)

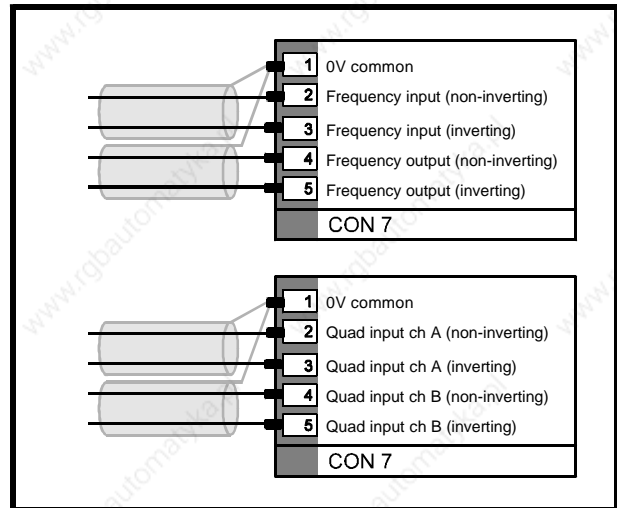

Figure 4-8 Connections for frequency input and output signals, quadrature and encoder input.

5 Setting Jumpers

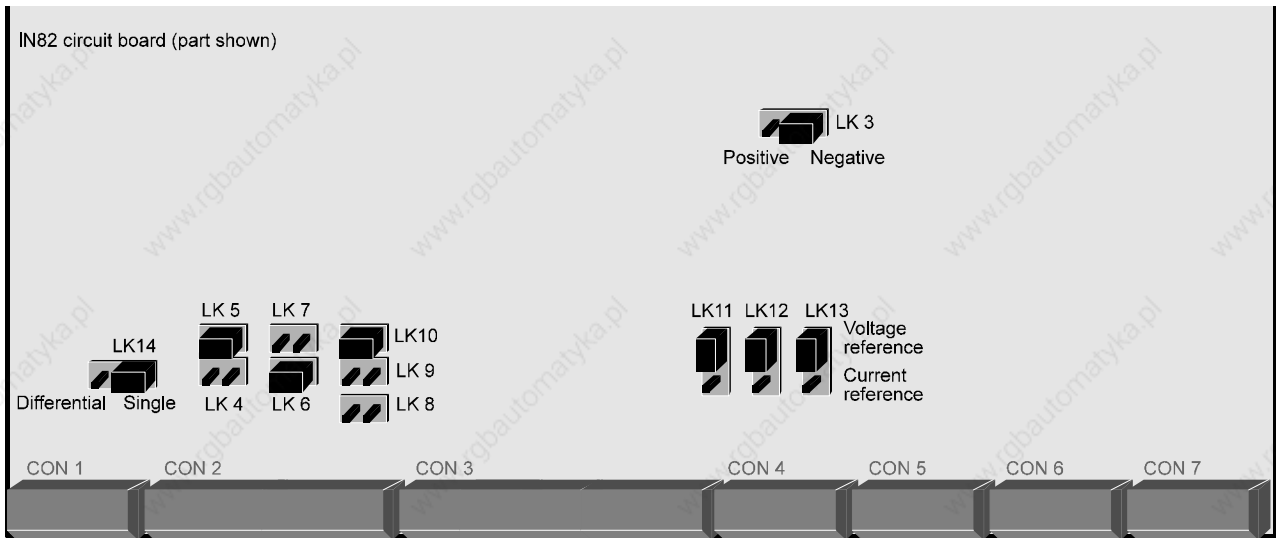

Figure 5-1 Approximate locations of the jumpers on the IN82 board

Prior to operation of the Drive it may be necessary to adjust the position of one or more of the jumpers on the IN82 board. Their approximate locations are as shown in Figure 4-1, which shows the default settings.

LK3

Selects positive or negative logic for the control connections

Default: Negative logic

Link	Logic 1 switched	Logic 0 open circuit
Positive	+24V	Internal pull down
Negative	0V	Internal pull up

LK4

LK5

Channel 1 analog speed reference input signal selection, as follows:

LK4 selects current speed reference input signal

LK5 selects voltage speed reference input signal

Default: LK5 — Voltage input

LK6

LK7

Channel 2 analog speed reference input signal selection, as follows:

LK6 selects current speed reference input signal

LK7 selects voltage speed reference input signal

Default: LK6 — Current input

LK8

LK9

LK10

Channel 3 analog input selection, as follows:

LK8 selects motor thermistor input signal

LK9 selects current speed reference input signal

LK10 selects voltage speed reference input signal

Default: LK10 — Voltage speed reference input

LK11

Channel 1 analog output

Selects voltage or current reference output

Default: Voltage output

LK12

Channel 2 analog output

Selects voltage or current reference output

Default: Voltage output

LK13

Channel 3 analog output

Selects voltage or current reference output

Default: Voltage output

LK14

Channel 1 analog input

Connected: Single ended input

Disconnected: Differential inputs

6 Control Keypad

The Control Keypad has a display area and a keypad.

The display is used for the following:

- Reading values of parameters
- Reading character strings held in certain parameters instead of values
- Reading status messages
- Reading trip codes

The keypad is used for the following:

- Programming the parameters
- Controlling the motor

6.1 Display

The display has three modes of operation, as follows:

Status mode

This is the normal working mode of operation

Parameter mode

Allows a menu and parameter to be selected using the keypad

Edit mode

Allows the selected parameter to be edited (change the value or character string)

These modes are selected using the keypad.

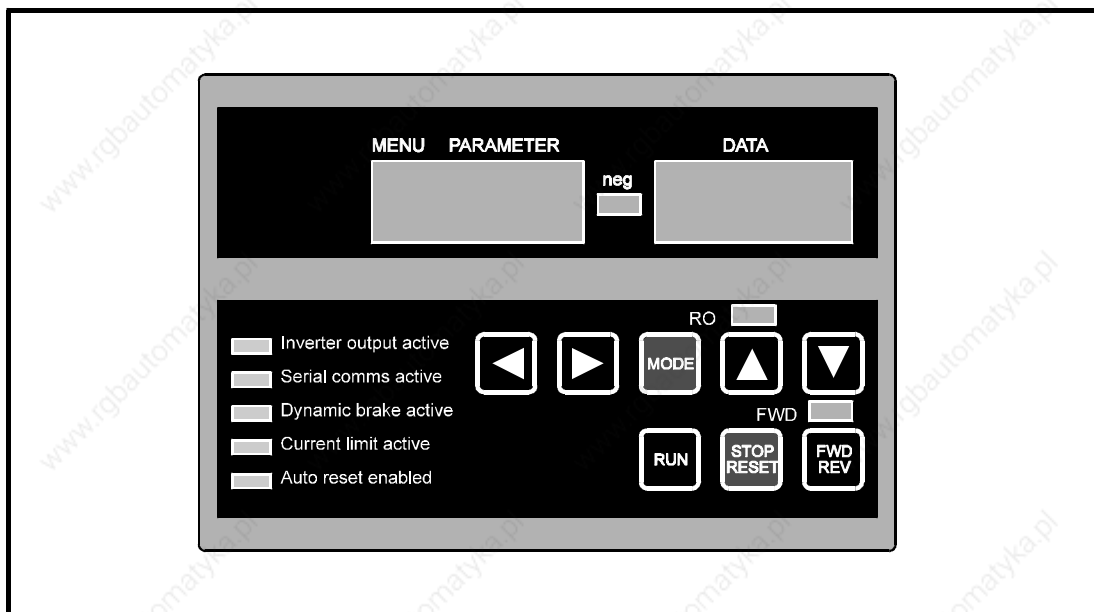

Figure 6-1 Control Keypad

The display area has a **MENU PARAMETER** window and a **DATA** window. The information that is displayed in these windows depends on the mode of operation of the Drive, as follows:

Mode	MENU PARAMETER window	DATA window
Status	Status of the Drive	Value or character string of the last parameter that was selected
Parameter	Selected menu Selected parameter	'b' is displayed when a bit parameter is selected
Edit	Selected menu Selected parameter	Value of the selected parameter (one digit flashes) or Character string of the selected parameter (whole string flashes)

When **Edit** mode is selected and the **DATA** window displays a numerical value, one of the digits flashes to show that it can be changed using the keypad. When a character string is displayed, all the characters flash to show that a different string can be selected.

6.2 Keypad

The keys are arranged in two rows.

The functions of the keys in the top row are as follows:



Display in Parameter mode: select a menu
Display in Edit mode: select a digit



Display in Parameter mode: select a parameter in the selected menu
Display in Edit mode: change the value of the selected parameter



Display in Parameter mode: selects **Edit**
Display in Edit mode: selects **Parameter** mode

When the display is in **Status** mode, pressing any one of the keys in the top row selects **Parameter** mode

The keys in the bottom row are as follows:



When these keys are configured to be active (by closing digital input F8), they can be used to control the motor. (Refer to Menu 6 in Chapter 11 *List of Parameters*.)

6.3 Status indicators

LED indicators on the Control Keypad indicate the following:

NEG

Illuminates when the displayed data value is negative.

Location: left of the **DATA** window

RO

Indicates that the displayed parameter is read-only.

Location: above the **MODE** key

FWD

Illuminates when the Drive has received the command to RUN in the forward direction.

Location: above the **FWD REV** key

Inverter output active

The Drive is controlling the motor (rotating or stopped).

Serial comms active

The Drive is receiving or transmitting data using serial communications. Parameter values can then be remotely read and changed (the Control Keypad can still be used).

Dynamic brake active

Indicates the motor is using the braking resistor due to deceleration (when an IN42 Braking Card is installed).

Current limit active

The Drive is operating in current limit.

Auto reset enabled

Warns that the Drive may be automatically reset after a trip and re-start.

6.4 Displays in Status Mode

When the display is in Parameter mode, and no Control Keypad keys have been pressed for at least eight seconds, the display reverts to Status mode. The **MENU PARAMETER** window then shows one of the following:

rdY

The Drive is waiting for a command.

run

The Drive is operating. The **DATA** window shows the value of the selected parameter.

StoP

A **STOP** command has been given. The Drive is decelerating the motor. Note that the motor may not stop immediately.

inh

The Drive is disabled, allowing the motor to turn freely.

SCAN

The Drive is synchronising itself to a spinning motor.

dc

DC injection braking being applied.

6.5 Display in the event of a Trip

triP

A Trip has occurred; the Drive is not controlling the motor. The **DATA** window displays the Trip Code.

7 Programming Instructions

7.1 Menu structure

The Drive is programmed by entering values into parameters. The parameters are held in menus that group the parameters according to their functions.

The first menu is **Menu 0** which is the **User Menu**. This contains the basic parameters that may be read or adjusted for simple applications.

The remaining menus are the **Advanced Menus**. These contain all the parameters that may be read or adjusted for advanced applications.

The parameters in Menu 0 are duplicates of certain parameters in the advanced menus; for example, parameter **p0.13** is a duplicate of **p1.04** (Keypad speed reference).

7.2 Types of parameters

There are two types of parameter, as follows:

Bit parameters

Bit parameters can be set in either of two logic states and are used as on/off or change-over switches.

Bit parameters are prefixed with the letter **b** (eg. **b1.11**).

Variable parameters

Variable parameters can be set at a value within a specified range. They are used to set numerical values, or to set the positions of switches having more than two options.

Variable parameters are prefixed with the letter **p** (eg. **p1.25**).

Certain parameters contain character strings instead of numerical values. The character strings are displayed on the Control Keypad in place of values. When these parameters are accessed and edited using serial communications, a numerical equivalent is displayed on the host computer. The numerical equivalent is used for programming these parameters. Refer to Chapter 11 Serial Communications.

These operating instructions are based on the Drive being in **Status** mode. (When AC power is applied to the Drive, the display is automatically in **Status** mode.)

Note

If the behaviour of the display does not appear as described in the operating instructions, refer to Chapter 10 Security.

7.3 Select a parameter for display (Parameter mode)



1. Press one of the following keys:



Parameter mode is now selected.

2. The parameter that was last selected is displayed in the **MENU PARAMETER** window. The value of this parameter is displayed in the **DATA** window.

3. Press  or  to select the required menu. The **MENU** window shows the menu number.

Press  or  to select the required parameter. The **MENU PARAMETER** window shows the parameter number. The **DATA** window shows the value or character string of the selected parameter.

If no key is pressed for at least eight seconds, the display returns automatically to **Status** mode.

7.4 Edit a parameter value (Edit mode)

Note

Only read–write parameters can be edited.

Editing a parameter value entails using keypad keys to scroll the displayed digits up or down in value. One digit at a time can be selected to be scrolled; other digits can be selected as required for scrolling.

1. Use the procedure in Select a parameter for display (above) to select the parameter to be edited.

2. Press 

Edit mode is now selected.

3. The least significant digit in the **DATA** window flashes to show that it is selected for editing. If a character string is displayed, the whole string flashes.
4. To change the value of the selected digit (or to select a different character string), press:

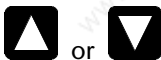

Note

While you are changing a digit for a variable parameter, the value of the parameter could fall outside the permitted range. If this happens when adjusting a digit other than the least significant digit, the maximum or minimum value flashes in the **DATA** window. For the options that now become available for setting the value, refer below to *Maximum and minimum values*.

5. To select a different digit, press:



6. To make the new value take effect, press



Note

New values given to parameters that require the Drive to be reset do not take effect until the Drive is reset. (See Reset the Drive.)

Parameter mode is now selected.

The display remains in Edit mode until  is pressed.

7.5 Maximum and minimum values

Depending on which limit is exceeded, the maximum or minimum value for the selected parameter flashes on the display when the displayed value falls outside the permitted range while one of the following keys is pressed:



The options that are available for setting the value of the parameter depend on when the key is released. The options are as follows:



Enter the previous valid value

Within three seconds (before the display stops flashing), release the key to set the parameter at the last valid value that was entered.





Enter the maximum or minimum value

Keep the key pressed for at least three seconds (until the display stops flashing). Then release the key to set the parameter at the maximum or minimum value.

7.6 Restore all parameters to their default values

1. Make sure the Drive is disabled and that the motor is not being driven.
2. Select any menu.
3. Set the parameter number at **00**.
4. Press 
5. Set the **DATA** value at **255**.
6. Press 
7. The default values are entered into all the parameters.

7.7 Save edited parameter values

1. Select any menu.
 2. Set the parameter number at **00**.
 3. Press 
 4. Set the **DATA** value at **001**.
 5. Press 
 6. If the Drive is not running or is operating in Terminal Mode, press:

 7. If the Drive is in Keypad Mode and is running, press and hold at the same time:
 and 
- All new parameter values are saved.

7.8 Reset the Drive

The Drive must be reset in order to perform the following functions:

- To clear a trip
- To make new values active for certain parameters
- To store parameters
- To load default parameters
- To start the magnetizing current measurement (**p0.14**) (**p5.16**)

Note

When the Drive is reset in order to perform either of the last two functions, the Drive must be stopped.

The Drive can be reset in the following ways:

- Applying a 0-to-1 signal transition to a terminal that is programmed to control parameter **b10.24**.
- Pressing the **STOP/RESET** key under either of the following conditions:
 - The Drive is not running
 - The **STOP** switch is not enabled (**b6.16** set at 0)
- Pressing the **RUN** and **STOP/RESET** key when all the following conditions occur:
 - The Drive is running
 - The **STOP/RESET** key is enabled (**b6.16** set at 1).
 - The **STOP/RESET** switch is pressed
- Using serial communications or an MD29 program. This is done by setting parameter **p10.30** at **70**.

8 Getting Started

The Drive may be controlled in either of the following modes:

Terminal mode

The motor is controlled by applying signals to the **START**, **STOP** and **SPEED REFERENCE** inputs.

Keypad mode

The motor is controlled using the Control Keypad.

8.1 Motor ratings

Enter the following data from the motor rating plate:

Data	Enter into parameter...
Motor rated current	p0.05
Motor rated voltage	p0.09
Number of motor poles	p0.18

To get the motor running, follow the appropriate procedure below.

8.2 Operating in Terminal Mode

Warning

Before proceeding, disconnect AC power from the Drive.

1. Make control connections as shown in Figure 8-1.
2. Ensure the following settings are made:
SPEED potentiometer is set at minimum
START switch is open
3. Connect AC power to the Drive.
4. Check the **MENU** and **PARAMETER** digits on the control keypad display **rdY**.

5. Close the STOP switch.
6. Check that the **Inverter output active** LED is illuminated.
7. Slowly adjust the SPEED potentiometer and check that the motor speed increases and reduces accordingly.
8. Set the SPEED potentiometer at maximum to run the motor at full speed.
9. Display parameter 0.20 Speed Output frequency and note the value.
10. Open the STOP switch and check the motor stops.

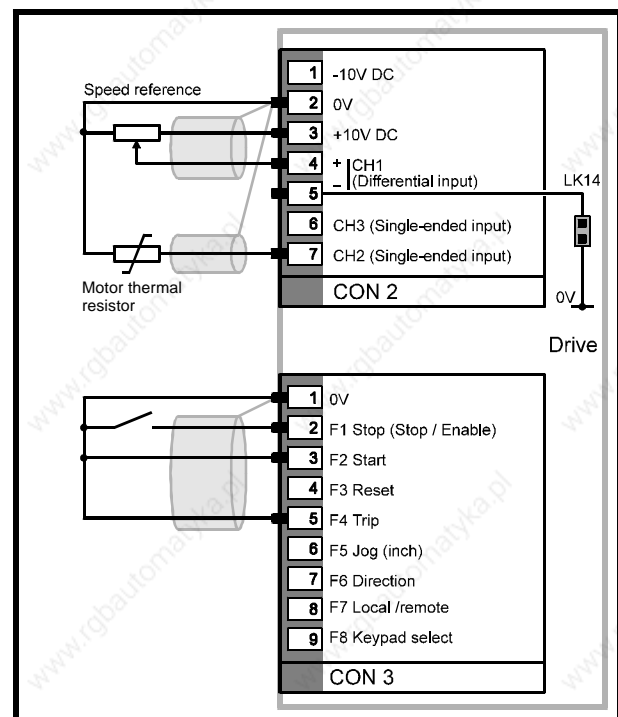

Figure 8-1 Basic control connections for operating the Drive in Terminal Mode

8.3 Operating in Keypad Mode

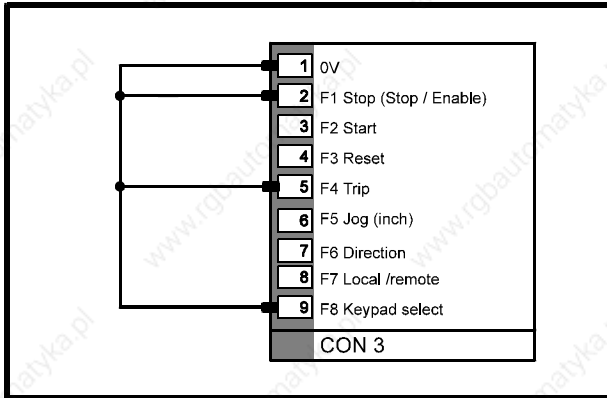











Figure 8-2 Connections for operating the Drive in Keypad Mode

1. Connect together pins 1, 2, 5 and 9 of connector CON 3 as shown in Figure 8-2.
2. Connect AC power to the Drive.
3. Check the MENU PARAMETER window displays **rdY**.
4. Press 
5. Check that the **Inverter Active** LED on the Control Keypad is illuminated.
6. Check that the MENU PARAMETER window displays **run**.
7. Press one of the following keys:





8. Select parameter **p0.13** or **p1.04**.
9. Press 
10. Press  to increase the value of the selected parameter (**p0.13** or **p1.04**). Note that the DATA window displays the frequency (speed) reference of the Drive. Check the speed of the motor increases while the key is pressed. Release the key and check the speed remains constant.
11. Press  and check the speed reduces.
12. Press 
13. Check the MENU PARAMETER window displays **Stop**. Check the motor decelerates and stops.
14. If required, set parameter **p11.30** at **0.13** for the display to show the Drive frequency (speed) reference next time AC power is applied.

9 Trip codes

Trip codes automatically appear in the **DATA** window.

CL1

Trip Code number: 1 Loss of current loop 1

When parameter **p7.10** is set at **3** or **4**, this trip occurs when analog speed reference 1 current input (4–20 mA or 20–4 mA) is less than 3.0mA.

Et

Trip Code number: 2 External trip contact has operated

A trip signal has been received on pin 5 of connector CON 3. Refer to parameter **p8.13** in Menu 8 and **b10.29** in Menu 10 in Chapter 11 *List of Parameters*.

l.t

Trip Code number: 3 Integrating overload lxt

Actual motor current has exceeded the rated current of the motor for an excessive period. (Value of parameter **p4.01** {current feedback} 105% of parameter **p5.06** {motor rated current}).

Oh

Trip Code number: 4 Heatsink over-temperature

The Drive heatsink has reached its upper working temperature (parameter **p7.04**). On model 2 size Drives, this may also indicate that the inrush contactor has failed to close.

OIAC

Trip Code number: 5 Instantaneous AC over-current trip

Excessive current in the output stage of the Drive, possibly indicating an external short-circuit.

OU

Trip Code number: 6 DC bus over-voltage

Over-voltage of the AC supply or motor regeneration causing the DC bus to exceed the following:

CDE	810V
CDLE	460V.

Ph

Trip Code number: 7 Supply-phase loss

Partial or complete loss of one or more AC supply phases.

PS

Trip Code number: 8 Internal power supply fault

Consult the supplier of the Drive.

th

Trip Code number: 9 Motor thermal resistor trip

Indicates the value of the motor thermal resistor connected to pin 7 of connector CON 2 is greater than 3k Ω (parameter **p7.16** set at 9 or 10 {thermal trip input}, and jumper 8 connected).

OldC

Trip Code number: 10 Instantaneous DC over-current trip

Excessive current in the DC bus of the Drive, possibly indicating an external short-circuit.

EPS

Trip Code number: 11 External power supply fault

Current overload trip on the +24V supply to external devices.

thS**Trip Code number: 12
Motor thermal resistor short-circuit**

Indicates the value of the motor thermal resistor connected to pin 7 of connector CON 2 is less than 100Ω (parameter **p7.16** set at 9 {thermal trip input}, and jumper 8 connected).

UU**Trip Code number: 13
DC bus under-voltage**

CDE: The DC bus voltage is below 320V
CDLE: The DC bus voltage is below 210V.

SCL**Trip Code number: 14
Serial comms. Loss**

Loss of data when serial communications in use (**p11.24** set at 2).

POdL**Trip Code number: 15
Loss of Control Keypad**

Communications between the Drive and the Control Keypad has failed (occurs only when the STOP key is enabled and the Drive is running).

cL2**Trip Code number: 16
Loss of current loop 2**

When parameter **p7.13** is set at **3** or **4**, this trip occurs when analog speed reference 2 current input (4–20 mA or 20–4 mA) is less than 3.0mA.

cL3**Trip Code number: 17
Loss of current loop 3**

When parameter **p7.16** is set at **3** or **4**, this trip occurs when analog speed reference 3 current input (4–20 mA or 20–4 mA) is less than 3.0mA.

EEF**Trip Code number: 18
EEPROM fault**

Consult the supplier of the Drive.

Prc2**Trip Code number: 19
Processor 2 fault**

Indicates a malfunction of processor 2 (MD29), or of the application software bus.

OA**Trip Code number: 20
Ambient over-temperature**

Excessive air temperature for the logic circuits in the Drive. At 80°C the Drive will trip and can only be reset at 75°C.

rS**Trip Code number: 21
Stator resistance measurement failure****OUSP****Trip Code number: 22**

Indicates the Drive is in regenerating current limit and the speed has increased to maximum.

hFPP**Trip Code numbers: 26 to 39
Hardware fault**

Consult the supplier of the Drive.

8.8.8.8.**Ixt trip warning (flashing dots)**

Actual motor current exceeds the rated current of the motor. (Value of parameter **p4.01** {current feedback} 5% greater than parameter **p5.06** {motor rated current}).

10 Security

Security operates at two levels to prevent unauthorized editing of parameters:

Standard Security

When locked, Standard Security prevents reading and editing of all the parameters in the **Advanced Menus**, but allows reading and editing of the parameters in the **User Menu (Menu 0)**.

A fixed code number is used to unlock Standard Security.

User Security

User Security operates only when it has been set-up by the user. When locked, it prevents editing of all parameters in all the menus except for the following parameters:

- Parameters **p0.13 / p1.04** (Keypad speed reference)
- Parameter **00** in the selected menu (eg. **07.00**). This is used to unlock Security.

The code number used to unlock User Security is defined by the user. This gives protection against unauthorized editing of parameters. The code number can be read and edited only when User Security has been unlocked.

When AC power is applied to the Drive, Standard Security and User Security (when set-up) are automatically locked.

10.1 Unlocking Standard Security

When AC power is applied to the Drive, Standard Security is automatically locked. Only the parameters in Menu 0 can be displayed on the Control Keypad for reading and editing.

To read and edit parameters in the Advanced Menus, Standard Security must first be unlocked. Use the following procedure to unlock Standard Security.

1. Select parameter **00.00**.

2. Press 

3. Set the value at 149.

4. Press 

All the parameters can then be read and edited unless **User Security** has been set.

10.2 Unlocking User Security

When User Security has been set-up and AC power is applied to the Drive, User Security is automatically locked. Except for parameters **00.00** in each menu, and **p0.13 / p1.04**, no parameters can be edited.

Use the following procedure to unlock User Security:

1. Select a menu. Parameter **xx.00** in the selected menu is displayed.

2. Press 

3. Set the value at the required number for User Security. (See Setting-up User Security.)



4. Press 

All read-write parameters can now be edited. (Standard security must be unlocked to enable read-write parameters in the advanced menus to be edited.)

10.3 Setting-up User Security

The Drive is supplied without User Security having been set-up. Consequently, when Standard Security is unlocked using the fixed code number, all parameters can be read and all read-write parameters can be edited.

Use the following procedure to set-up User Security:

1. Unlock Standard Security.
2. Select parameter **p11.29**.
3. The default value **149** is displayed.
4. Press 
5. Change the value to the required User Security number (not 149).
6. Press . The displayed value reverts **to149**. This 'hides' the User Security number.
7. Follow the procedure in Save edited parameter values.

User Security is now set-up.

10.4 Locking Security

When AC power is removed and subsequently re-applied, Standard Security and User Security (when set-up) are locked.

Use the following procedure to lock Security without removing AC power:

1. Select a menu. Parameter **xx.00** in the selected menu is displayed.

2. Press 

3. Set the value at 2.

4. Press 

If User Security has not been set-up, the MENU window now displays **Menu 0**. The parameters in Menu 0 can be read or edited.

If User Security has been set-up, the PARAMETER window now displays **Menu 0**. Only the following parameters can now be edited:

- Parameters **p0.13 / p1.04** (Keypad speed reference)
- Parameter **00** this is used to unlock Security

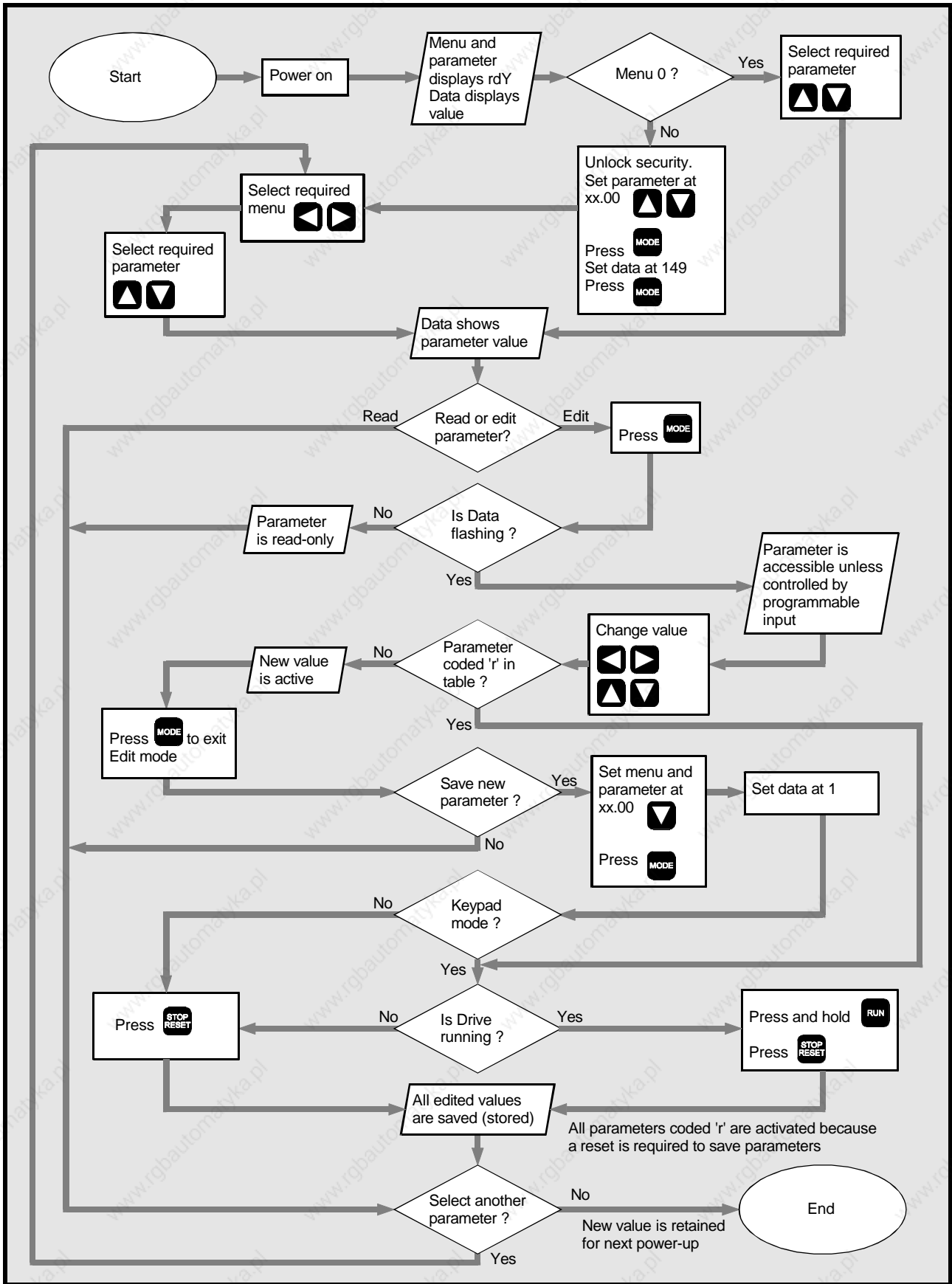

Figure 10-1 Editing, saving and security

11 List of Parameters

11.1 Values and character strings

For parameters containing character strings, the following lists give the character strings as well as their numeric equivalents. When these parameters are accessed using serial communications, the numeric equivalents are used.

Note

Some parameters have alternative default values for certain versions of the Drive.

11.2 Parameter XX.00

Parameter **00** in each menu gives access to the following:

- Set at 1 to save parameter values
- Set at 255 to restore parameters to default values
- Set at 149 to access standard security

11.3 List of menus

- 0 User Menu
- 1 Frequency reference selection, limits and filters
- 2 Ramps
- 3 Frequency input and output
- 4 Current limits and torque control
- 5 Machine control
- 6 Operational modes
- 7 Analog inputs and outputs
- 8 Digital inputs
- 9 Digital outputs
- 10 Status logic, and diagnostic information
- 11 Miscellaneous
- 12 Programmable thresholds
- 13 Timer functions
- 14 PID control loop, and encoder feedback
- 15 MD29 setup
- 16 Application menu 1
- 17 Application menu 2

11.4 Codes used in the parameter lists

Parameter changing and saving

Parameters are automatically saved when AC power is removed. New values given to parameters become effective immediately. To save the new values permanently, follow the procedure in *Save edited parameter values* in Chapter 7 *Programming Instructions*.

Read–write and read-only parameters

Read–write parameters are shown as **R–W**.

Read-only parameters are shown as **RO**.

Europe and USA settings

Where applicable, the value for European versions is marked (EUR); the value for USA versions is marked (USA).

Default values

Default values are given for each parameter. The equivalent values for serial communications are given in square brackets.

11.5 Menu 0 — User Menu

For quick access to the parameters that may need to be adjusted for simple applications, the parameters in Menu 0 can be programmed without needing to search through the advanced menus.

If different parameters are required in Menu 0, they can be changed using parameters **p11.01** to **p11.20** in Menu 11.

XX.00	Null parameter	
--------------	-----------------------	--

p0.01 (p1.06)	Maximum frequency		R–W
Range	0 to 999.9 Hz	Default	50 (EUR) 60 (USA)

Defines absolute maximum output frequency.

See parameter **b1.10**.

p0.02 (p2.03)	Acceleration ramp		R–W
Range	0.1 to 3276 s/100Hz	Default	5

Acceleration ramp rate is expressed as the time in seconds for the output frequency to increase by 100Hz.

p0.03 (p2.04)	Deceleration ramp		R–W
Range	0.1 to 3276 s/100Hz	Default	10

Deceleration ramp rate is expressed as the time in seconds for the output frequency to decrease by 100Hz.

p0.04 (p4.11)	Symmetrical current limit		R–W
Range	0 to $\frac{p11.35}{p5.06} \times 100$ % of FLC	Default	150

Current limit for Motoring and Regenerating.

After having set the required value of rated motor current in **p0.05 (p5.06)**, you may increase or decrease the percentage overload current using **p0.04 (p4.11)**. The maximum percentage that can be set is limited by the overload current rating of the Drive. The limit applies when motoring and regenerating.

The value of **p0.04 (p4.11)** is automatically reduced when the value of **p0.05 (p5.06)** is increased beyond the default value.

p0.05 (p5.06)	Rated motor current		R–W
Range	0 to p11.33 A	Default	Rated current of the Drive

Enter the value of continuous rated motor current. When the value is increased beyond the default value of the Drive, the value of **p0.04 (p4.11)** is automatically decreased.

$$I_{\text{torque}} = p0.05 \times p5.13$$

The value entered affects the following:

- Slip compensation
- Dynamic V/f
- Ixt detection level

p0.06 (p5.12)	Voltage control mode selector		R–W
Range	[0] to [4]	Default	Ur_I [3]

- Auto [0] Auto boost
- Fd [1] Fixed boost
- Ur_S [2] Vector mode. Stator resistance is measured at start
- Ur_I [3] Vector mode. Stator resistance is measured at power-up only
- Ur [4] Vector mode. Stator resistance is not measured

See parameter **p5.12**.

p0.07 (p5.07)	Rated motor RPM at full load		R–W
Range	0 to 9999 RPM	Default	0

Enter the value from the motor rating plate. This is used by the Drive to apply correct slip compensation. If no slip compensation is required, set **p0.07 (p5.07)** at 0 (default).

p0.08 (p6.04)	Injection braking level		R–W
Range	0 to $\frac{p11.35}{p5.06} \times 100$ % of FLC	Default	150

If the injection braking level is set too low the Drive will not stop. If a low injection level is required, use the timed dc injection td.dc by setting **p0.12** at **td.dc** [4].

p0.09 (p5.08)	Rated motor voltage		R–W
Range	100 to 480 VRMS	Default	400 (EUR) 460 (USA)

Enter the value from the motor rating plate in order to define the maximum output voltage of the Drive. See parameter **p5.12**.

b0.10 (b4.07)	Select torque mode		R-W
Range	0 or 1	Default	0

Set **b0.10** at **0** to select speed reference.

Set **b0.10** at **1** to select torque reference. The PID controller uses the same P and I terms as the current limits defined in **p4.08** and **p4.09**.

It is possible to change between torque control and frequency control when the Drive is running without causing transient frequency changes.

p0.11 (p6.02)	Auto-start mode		R-W
Range	[0] to [2]	Default	dis [0]

dis	[0]	The Drive does not start when AC power is applied
ALYS	[1]	The Drive always starts when AC power is applied
Pd.dP	[2]	The Drive starts only if it had been running when AC power was previously removed.

See parameter **p6.02**.

p0.12 (p6.01)	Stop mode		R-W
Range	[0] to [4]	Default	rp [0]

rP	[0]	The Drive ramps to zero speed
inh	[1]	Inhibit (coast to stop)
dc	[2]	DC injection braking
rP.dc	[3]	Ramp + DC injection braking
td.dc	[4]	Timed DC injection braking

See parameter **p6.01**.

p0.13 (p1.04)	Keypad reference		R-W
Range	Bipolar: \pm p1.06 Hz Unipolar: p1.05 to p1.06	Default	0

Saved at power-down.

Frequency reference when the Control Keypad is used to control speed (see Menu 3).

Enter a value using the Control Keypad. Set **p11.30** at **p0.13 (1.04)** to display the parameter at power-up.

p0.14 (p5.16)	Magnetizing current test		R-W
Range	0 to 9999	Default	0

Automatically saved.

Warning

The motor runs at half maximum speed while this test is performed.

Ensure the stop switch is closed.

Set **p0.14 (p5.16)** at 255 to start the test.

Reset the Drive to enter the new value of power function in **p5.13**.

b0.15 (b6.06)	Switching frequency		R-W
Range	[0] or [1]	Default	3 [0]
	3 [0]	3kHz	
	6 [1]	6kHz (Model size 1 only)	

b0.16 (b6.24)	Catch spinning motor		R-W
Range	0 or 1	Default	0

See parameter **b6.24**.

p0.17 (p1.14)	Jog reference		R-W
Range	0 to 999.9 Hz	Default	1.5

Frequency reference for Jog.

p0.18 (p5.10)	Number of motor poles		R-W
Range	2 poles [0] 4 poles [1] 6 poles [2] 8 poles [3]	Default	4p [1]

Enter the value from the motor rating plate for correct slip compensation and RPM indication.

p0.19 (p4.02)	Current feedback (load)		RO
Range	0 to \pm p11.35 A	Default	

Indicates the magnitude of the torque-producing motor current.

p0.20 (p5.02)	Motor shaft RPM		RO
Range	0 to 9999 RPM	Default	

Indicates motor shaft RPM.

The number of poles must be entered correctly in **p0.18 (p5.10)**, and the slip correction must not be at the maximum frequency limit [if the motor is to run at 50Hz, set p0.01 at a higher value to allow for slip compensation].

11.6 Menu 1 — Frequency reference, limits and filters

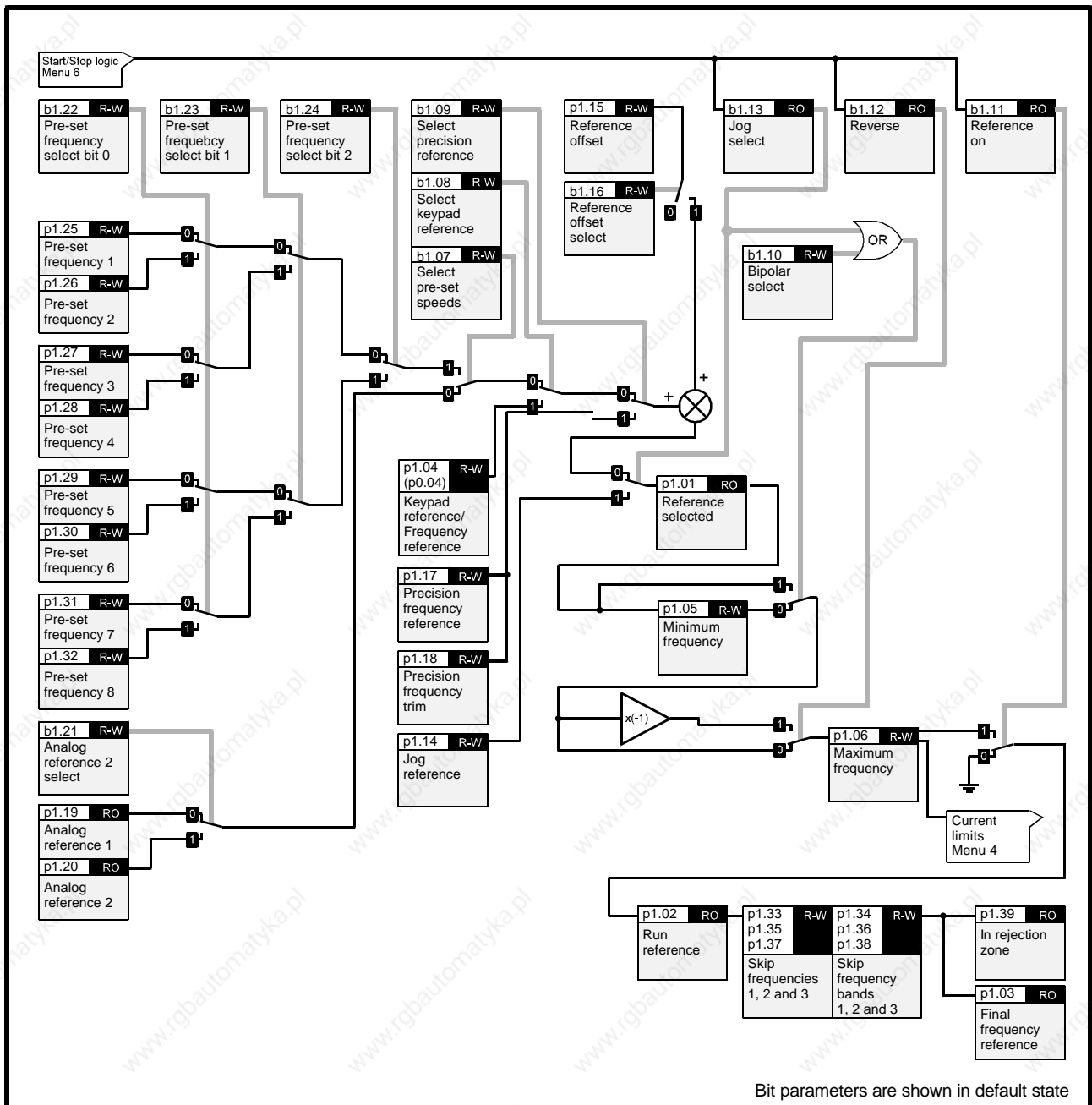

Note

For controlling read–write parameters and for displaying read-only parameters, refer to the following:

- Menu 7 — Analog inputs and outputs
- Menu 8 — Programmable digital inputs
- Menu 9 — Programmable digital outputs

p1.01	Reference selected			RO
Range	±999.9	Hz	Default	

Indicates the frequency reference. This can be used for setting up the system and fault finding.

p1.02	Run reference			RO
Range	±p1.06	Hz	Default	0.0

Indicates the run frequency reference. This can be used for setting up the system and fault finding.

p1.03	Final frequency reference			RO
Range	±p1.06	Hz	Default	0.0

Indicates the final frequency reference. This can be used for setting up the system and fault finding.

p1.04	Keypad reference			R-W
Range	Bipolar: ±p1.06 Unipolar: p1.05 to p1.06	Hz	Default	0

Saved at power down.

Frequency reference when the Control Keypad is used to control speed (see Menu 3).

Enter a value using the Control Keypad. Set **p11.30** at **p1.04** to display the parameter at power-up.

p1.05	Minimum frequency			R-W
Range	0 to p1.06	Hz	Default	0

Use in unipolar mode to define the minimum output frequency of the Drive. This can be over-riden by **p1.06** and is inactive during Jog.

p1.06	Maximum frequency			R-W
Range	0 to 999.9	Hz	Default	50 (EUR) 60 (USA)

Enter a value to define the absolute maximum output frequency.

b1.07	Select pre-set speeds			R-W
Range	0 or 1	Default	0	

Set at 1 to select pre-set speeds.

b1.08	Select keypad reference			R-W
Range	0 or 1	Default	0	

Set at 1 to select control using the Control Keypad.

b1.09	Select precision reference			R-W
Range	0 or 1	Default	0	

Set at 1 for high resolution (0.001Hz) frequency control.

Set at 0 for normal resolution (0.03Hz) frequency control.

b1.10	Bipolar select			R-W
Range	0 or 1	Default	0	

Set at 1 to select bipolar speed reference signal.

Set at 0 to select unipolar speed reference signal. Negative input signals are then treated as zero.

Analog operation

When **b1.10** is set at **0**, any analog input programmed to parameters **p1.19** and **p1.20** is scaled so that 100% corresponds to the maximum set for **p1.06**, and 0% corresponds to the minimum set for **p1.05**.

When **b1.10** is set at **1**, the analog input programmed to **p1.19** or **p1.20** is scaled so that ±100% corresponds to the maximum ± set for **p1.06**.

In addition, if an analog input programmed in voltage mode is directed to one of these parameters and the parameter is selected as the frequency reference, the scan-rate of the analog input is increased.

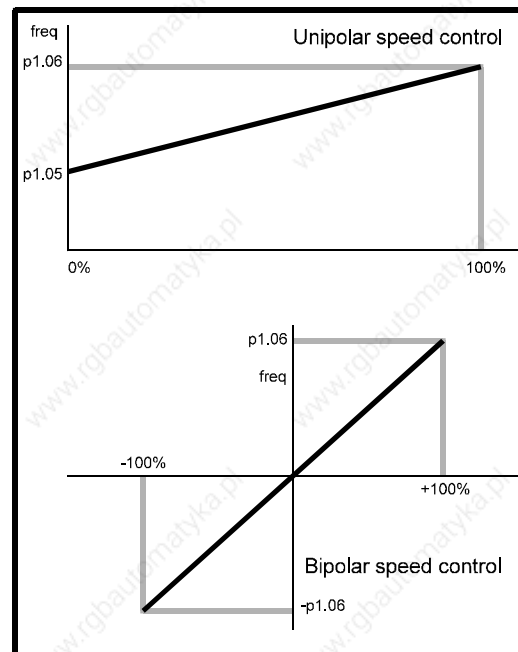

Figure 11-1 Scaling of the analog speed reference input

b1.11	Reference ON			RO
b1.12	Reverse			
b1.13	Jog select			
Range	0 or 1	Default	0.0	

These parameters are controlled by the Drive sequencer. See parameter **p6.07**.

p1.14	Jog reference			R-W
Range	0 to 999.9	Hz	Default	1.5

Frequency reference for Jog.

p1.15	Reference offset			R-W
Range	±999.9	Hz	Default	0

When **b1.16** is set at 1, the value entered into **p1.15** is added to the selected reference parameter. It is used to trim the selected parameter.

b1.16	Reference offset select			R-W
Range	0 or 1	Default	0	

Set at 1 to enable addition of the reference offset (**p1.15**).

p1.17	Precision frequency reference			R-W
Range	±999.9	Hz	Default	0

p1.18	Precision frequency trim			R-W
Range	0 to 0.099	Hz	Default	0

p1.19	Analog reference 1			RO
p1.20	Analog reference 2			
Range	p1.06	Hz	Default	0.0

See parameter **b1.10**

b1.21	Analog reference 2 select			R-W
b1.22	Pre-set frequency select bit 0			
b1.23	Pre-set frequency select bit 1			
b1.24	Pre-set frequency select bit 2			
Range	0 or 1	Default	0	

Select the required reference.

p1.25	Pre-set frequency 1			R-W
p1.26	Pre-set frequency 2			
p1.27	Pre-set frequency 3			
Range	±999.9	Hz	Default	0

Normal pre-set frequency references.

p1.28	Pre-set frequency 4			R-W
p1.29	Pre-set frequency 5			
p1.30	Pre-set frequency 6			
p1.31	Pre-set frequency 7			
p1.32	Pre-set frequency 8			
Range	±999.9	Hz	Default	0

Normal pre-set frequency references.

p1.33	Skip frequency 1			R-W
Range	0 to 999.9	Hz	Default	0

Enter a value to avoid a frequency which induces mechanical resonances.

p1.34	Skip frequency 1 band			R-W
Range	0 to 5.0	Hz	Default	0.5

Enter a value to define the frequency range either side of Skip frequency 1 over which frequencies are avoided. The bandwidth is twice that entered into this parameter.

p1.35	Skip frequency 2			R-W
Range	0 to 999.9	Hz	Default	0

Enter a value to avoid a frequency which induces mechanical resonances.

p1.36	Skip frequency 2 band			R-W
Range	0 to 5.0	Hz	Default	0.5

Enter a value to define the frequency range either side of Skip frequency 2 over which frequencies are avoided. The bandwidth is twice that entered into this parameter.

p1.37	Skip frequency 3			R-W
Range	0 to 999.9	Hz	Default	0

Enter a value to avoid a frequency which induces mechanical resonances.

p1.38	Skip frequency 3 band			R-W
Range	0 to 5.0	Hz	Default	0.5

Enter a value to define the frequency range either side of skip frequency 3 over which frequencies are avoided. The bandwidth is twice that entered into this parameter.

b1.39	In rejection zone			RO
Range	0 or 1	Default	0.0	

Indicates the selected reference is within one of the skip frequency bands. The motor speed does not match the demand.

This page is deliberately blank

11.7 Menu 2 — Ramps

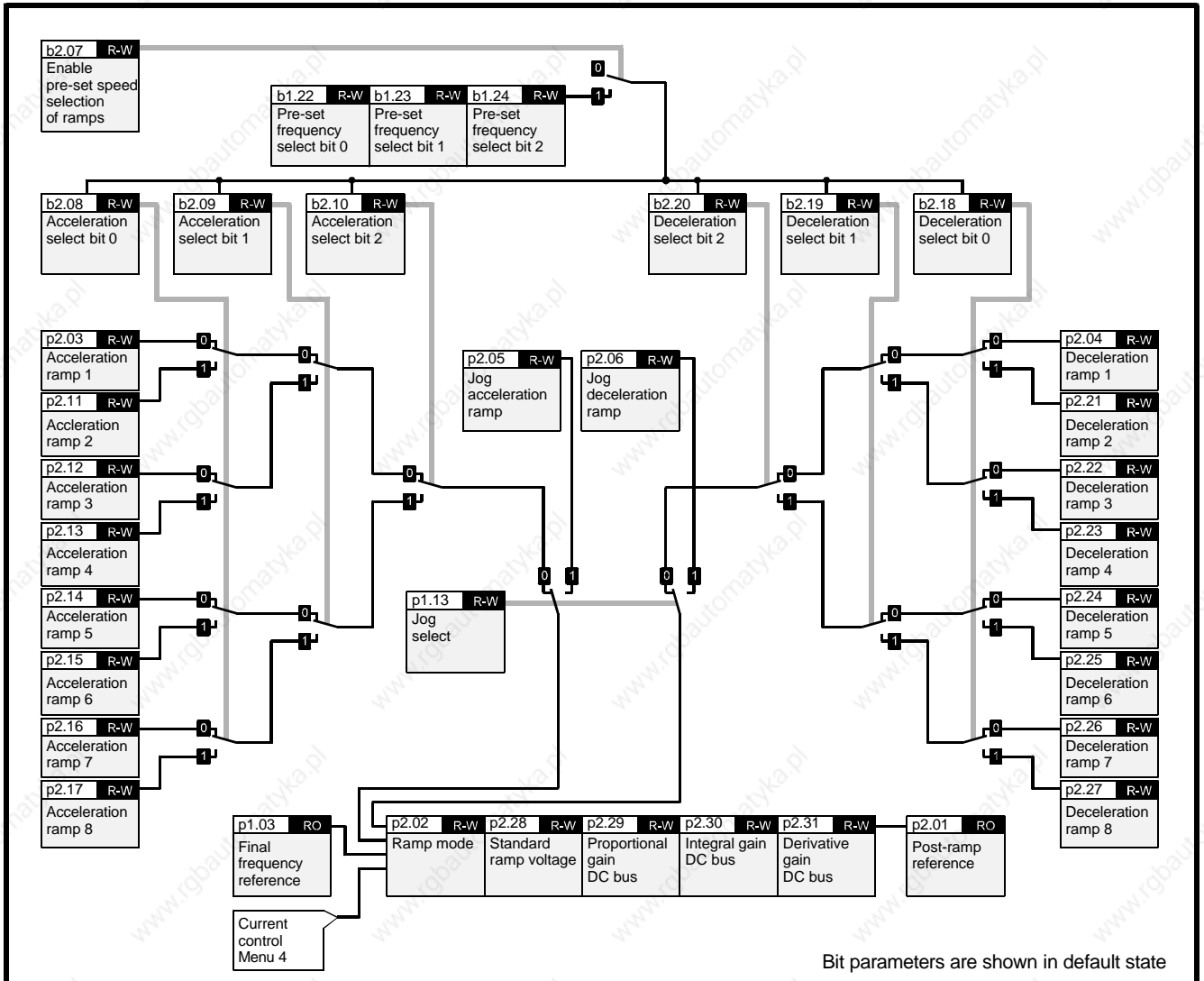

Bit parameters are shown in default state

Note

For controlling read–write parameters and for displaying read-only parameters, refer to the following:

- Menu 7 — Analog inputs and outputs
- Menu 8 — Programmable digital inputs
- Menu 9 — Programmable digital outputs

p2.01	Post-ramp reference			RO
Range	$\pm p1.06$	Hz	Default	0.0

Frequency reference after the effects of ramps and normal currents limits.

p2.02	Ramp mode		R–W
Range	[0] to [2]	Default	Std.C [2]

Select from:

- Std.H [0] Standard hold
- FAST [1] Fast
- Std.C [2] Standard controlled

Ramp modes

The Ramp Modes parameter **p2.02** controls deceleration ramps only. The settings are as follows:

Setting	Description	
0	Std.H	Standard-hold
1	FAST	Fast
2	Std.C	Standard-controlled

Mode 0 – Standard-hold mode

In Standard-hold mode, deceleration occurs in steps. The control causes the deceleration ramp to be 'frozen' when the DC bus voltage rises above the standard ramp voltage (set in **p2.28**). When the voltage drops below the Standard-ramp voltage, the ramp again begins to fall. Although this type of control does not usually give smooth deceleration especially if the motor is lightly loaded, it is easy to set up. A high voltage of AC supply could cause the Drive to trip on over-voltage due to transients that could be produced in the Standard-hold mode.

Mode 1 – Fast mode

The ramp falls at the programmed deceleration rate subject only to the current limits programmed.

This mode is normally used when a braking resistor is used.

The dynamic break becomes active at a DC bus level of 780V

Mode 2 – Standard-controlled mode

The PID controller is used to modify the ramp so that the DC bus voltage is held at the Standard-ramp voltage (set in **p2.28**). This gives smoother control than Standard-hold mode, but it may be necessary to use an oscilloscope to set up the PI gains.

Care should be taken in choosing the Standard-ramp voltage (using **p2.28**), because, if this is lower than the nominal DC bus voltage produced by the AC supply, the DC bus controller will accelerate the motor up to the maximum frequency (set in **p1.06**) in an attempt to reduce the DC bus voltage.

See **p2.28 – Standard ramp voltage**.

The Standard-controlled mode is useful in applications where smooth deceleration is required, particularly with lightly-loaded machines, or where the AC supply voltage is high.

Caution

The D term operates in Standard-controlled mode and under AC supply loss. Care must be taken not to have instability in either case due to an excessively high gain

p2.03 Acceleration ramp 1				R–W
Range	0.1 to 3276	s/100Hz	Default	5

Acceleration ramp rate is expressed as the time for the output frequency to increase by 100Hz.

For example, a programmed ramp time of 5 seconds causes the frequency to increase or decrease by 50Hz in 2.5 seconds.

p2.04 Deceleration ramp 1				R–W
Range	0.1 to 3276	s/100Hz	Default	10

Deceleration ramp rate is expressed as the time for the output frequency to decrease by 100Hz.

p2.05 Jog acceleration ramp				R–W
Range	0.1 to 3276	s/100Hz	Default	0.2

Acceleration ramp rate is expressed as the time for the output frequency to increase by 100Hz.

p2.06 Jog deceleration ramp				R–W
Range	0.1 to 3276	s/100Hz	Default	0.2

Deceleration ramp rate is expressed as the time for the output frequency to decrease by 100Hz.

b2.07 Enable pre-set speed selection of ramps			R–W
Range	0 or 1	Default	0

When **b2.07** is set at 1, **p2.08** to **p2.10** & **p2.18** to **p2.20** are updated from the pre-set frequency select parameters **p1.22** to **p1.24**. This allows pre-set acceleration and deceleration to change automatically with preselected speeds.

b2.08 Acceleration select bit 0			R–W
b2.09 Acceleration select bit 1			
b2.10 Acceleration select bit			
Range	0 or 1	Default	0

Binary coded selection of the required acceleration ramp to be used. (eg. to select **p2.13** – Acceleration ramp 4, set **b2.08** and **b2.09** at 1.)

p2.11	Acceleration ramp 2	R–W
p2.12	Acceleration ramp 3	
p2.13	Acceleration ramp 4	
p2.14	Acceleration ramp 5	
p2.15	Acceleration ramp 6	
p2.16	Acceleration ramp 7	
p2.17	Acceleration ramp 8	
Range	0.1 to 3276 s/100Hz	Default 5

Acceleration ramp rate is expressed as the time for the output frequency to increase by 100Hz.

b2.18	Deceleration select bit 0	R–W
b2.19	Deceleration select bit 1	
b2.20	Deceleration select bit 2	
Range	0 or 1	Default 0

Binary coded selection of the required deceleration ramp to be used. (eg. to select **p2.23** – Deceleration ramp 4, set **b2.18** and **b2.19** at 1.)

p2.21	Deceleration ramp 2	R–W
p2.22	Deceleration ramp 3	
p2.23	Deceleration ramp 4	
p2.24	Deceleration ramp 5	
p2.25	Deceleration ramp 6	
p2.26	Deceleration ramp 7	
p2.27	Deceleration ramp 8	
Range	0.1 to 3276 s/100Hz	Default 10

Deceleration ramp rate is expressed as the time for the output frequency to decrease by 100Hz

p2.28	Standard-ramp voltage	R–W
Range	0 to 800 V	Default 700 (EUR) 775 (USA) 390 (CDLE)

This parameter is used for Standard-hold and Standard-controlled modes.

The minimum level for the Standard-ramp voltage should be greater than the voltage produced on the DC bus by the highest AC supply voltage (normally RMS AC supply voltage $\times \sqrt{2}$).

When Standard-hold mode is used and the Standard-ramp voltage is set too low, the Drive will not stop. If the Standard-ramp voltage is set too high and no braking resistor is used, the Drive may trip on over-voltage.

When Standard-controlled mode is used and the voltage is set too low, the motor will accelerate to maximum frequency. (AC supply loss uses a fixed control voltage that is dependent on the voltage rating of the Drive.)

p2.29	Proportional gain	R–W
Range	0 to 99.99 % of max.	Default 1.00

Enter a value of proportional gain for the PID controller.

This is used to control the DC bus voltage during Standard-ramp deceleration and loss of AC supply.

p2.30	Integral gain	R–W
Range	0 to 99.99 % of max	Default 4.00

Enter a value of integral gain for the PID controller.

This is used to control the DC bus voltage during Standard-ramp deceleration and loss of AC supply.

p2.31	Derivative gain	R–W
Range	0 to 99.99 % of max.	Default 0.00

Enter a value of Derivative gain for the PID controller.

This is used to control the DC bus voltage during Standard-ramp deceleration and loss of AC supply.

The D term operates in Standard-controlled mode and under AC supply loss. Care must be taken not to allow instability in either case due to an excessively high gain.

p2.32	S-Ramp band	R–W
Range	0 to p1.06 Hz	Default 0

Enter a value to define the frequency band for the curve at each end of the S-ramp. Time taken for acceleration or deceleration on the curve is double that for a straight ramp.

If the ramp time changes during a change of speed, the S-ramp does not give stepless acceleration or deceleration. For example:

If different ramp rates are used for acceleration and deceleration, and the Drive passes through zero speed.

If the ramp rates are changed using the acceleration or deceleration select bits.

This page is deliberately blank

11.8 Menu 3 — Frequency input and output

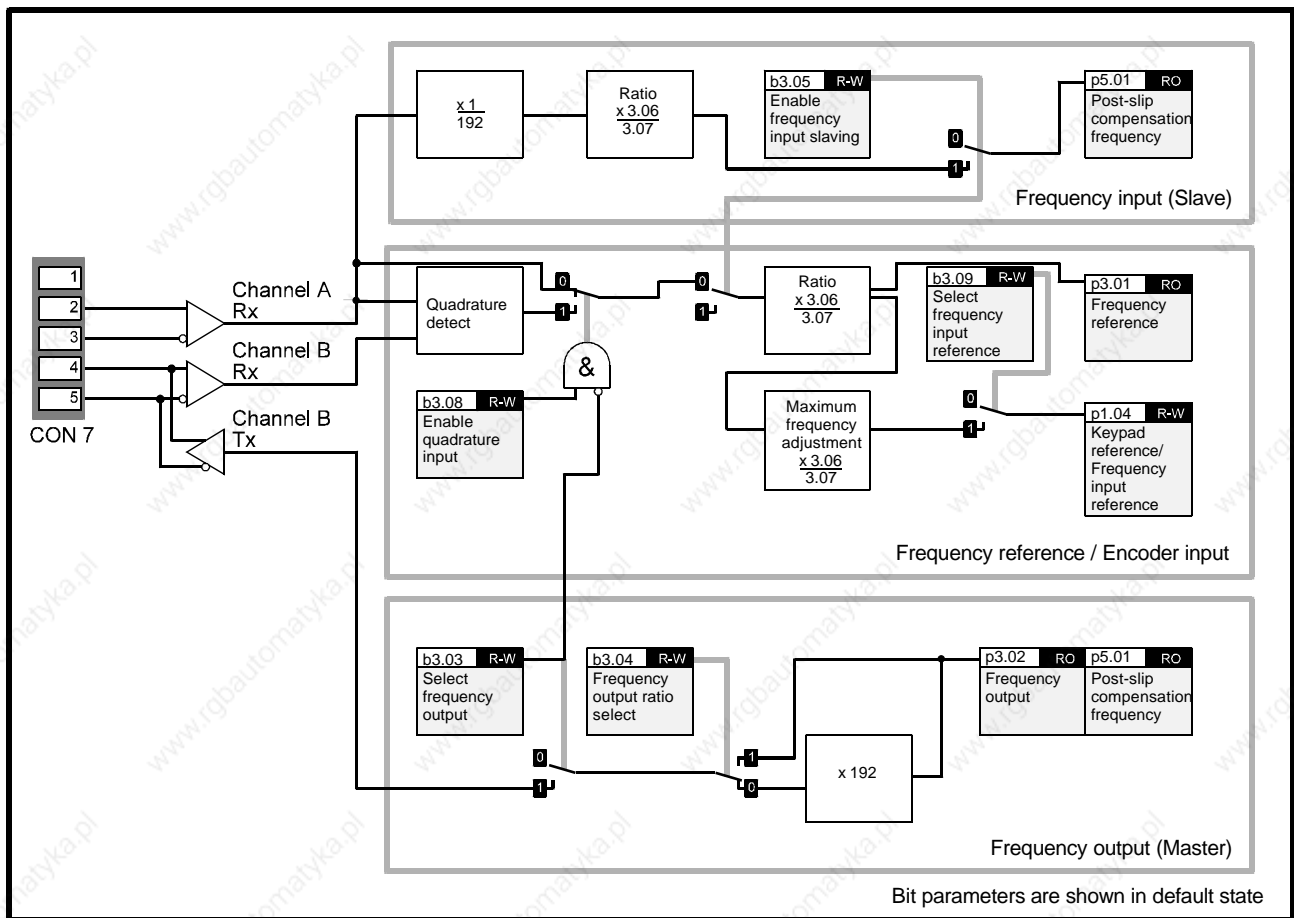

Note

For controlling read–write parameters and for displaying read-only parameters, refer to the following:

- Menu 7 — Analog inputs and outputs
- Menu 8 — Programmable digital inputs
- Menu 9 — Programmable digital outputs

p3.01	Frequency reference	RO
Range	±100.0 %	Default

p3.02	Frequency output	RO
Range	±999.9 Hz	Default

b3.03	Select frequency output	R–W
Range	0 or 1	Default 0

When **p3.03** is set at 1, **p3.04** is enabled.

b3.04	Frequency output ratio select	R–W
Range	0 or 1	Default x192 (0)

Set at 0 for showing (x192).

Set at 1 monitoring (x1).

Enables the **Frequency output** terminal to produce a frequency of x1 or x192 the fundamental frequency.

If **b3.04** is changed from 1 to 0 while the Drive is running, the **Frequency output** signal will cease until the Drive is re-started. This does not occur if **b3.04** is changed from 0 to 1

Frequency slaving

When used in a frequency-slaving system, the Drive can be set up as a Master, Slave or both. Frequency-slaving, parameter **b3.04** should be set at 0 to select x192 frequency ratio.

When a Drive is not required to operate as a Slave, the frequency input terminals can be used to accept a frequency pulse train (from a plc for example), or quadrature signals from an encoder.

b3.05	Enable frequency input slaving			R-W
Range	0 or 1	Default	0	

Set at 1 to enable frequency slaving. The output frequency follows the reference frequency at an exact ratio set in **p3.06** and **p3.07**.

p3.06	Frequency input ratio numerator			R-W
Range	0 to 2.000	Default	1.000	

Enter a value for the numerator of the required slaving ratio. The ratio cannot be greater than 2:1. The numerator **p3.06** may be changed without losing lock.

It is recommended to keep **p3.07** at the default setting.

p3.07	Frequency input ratio denominator			R-W
Range	0 to 1.000	Default	1.000	

Enter a value for the denominator of the required slaving ratio. The ratio cannot be greater than 2:1.

If **p3.07** is changed while the Drive is running, frequency locking between the Drives will not be maintained, and the Slave Drive may trip on OIAC.

It is good practice to stop the Drive first.

It is recommended to keep **p3.07** at the default setting.

Refer to the example on the previous page for correctly setting up the ratio.

b3.08	Enable quadrature input			R-W
Range	0 or 1	Default	0	

Set at 1 to enable encoder quadrature input.

This is not available when **p3.03** or **p3.05** are set at 1.

Quadrature input is not available if frequency output is required, since the B channel encoder input shares terminals with the frequency output.

The pulse-train frequency can be monitored by the Drive, and the measured frequency used to derive the frequency demand for the Drive. In either case, parameters **p3.06** and **p3.07** (frequency input ratio) must be set up to scale the input measurement so that read-only parameter **p3.01** indicates 100.0% when maximum input frequency is demanded.

The following equations should be used to calculate the scale factor required for different motor speeds and encoder lines:

(RPM = maximum motor speed
N = Number of encoder lines)

Encoder with Quadrature Counting enabled

$$\text{Scale} = \frac{464\,916}{\text{RPM} \times N}$$

Encoder without Quadrature Counting (no direction information)

$$\text{Scale} = \frac{929\,832}{\text{RPM} \times N}$$

Frequency pulse-train input

$$\text{Scale} = \frac{15\,497}{F_{\max}}$$

It is recommended that parameter **p3.07** is left at its default value of **1.000** and the result of the above calculations entered into parameter **p3.06**. If the result of the calculation is very low, the difference in top speed values becomes very coarse. If this occurs, adjust **p3.07** to finely tune the maximum measured input frequency.

Example

A 2048 quadrature encoder is fitted to a 3000 RPM motor

$$\text{Scale} = \frac{464\,916}{3000 \times 2048} = 0.07567$$

Only **0.075** can be entered in parameter **p3.06**. This value equates to a maximum speed of 3027 RPM.

A value for parameter **p3.07** can be calculated as follows:

$$\text{p3.07} = \frac{\text{p3.06}}{\text{Scale}} = \frac{0.075}{0.07567} = 0.991$$

Parameter **p3.01** can then be used either as an input to the PID software or a MD29 application program. If parameter **b3.09** is set at 1, **p3.01** can be used as a frequency reference for the Drive. In this case the 100.0% maximum in parameter **p3.01** is automatically scaled to give maximum frequency reference (**p1.06**) in the Control Keypad reference parameter.

Resolution

When the frequency reference input is used to control frequency demand (ie. slaving is not being used), the resolution of the reference is dependent on the maximum input frequency. It is not possible to obtain a higher resolution than 0.03Hz or a resolution from 0 to maximum frequency of greater than 1/4000 (or 0.025%). Subject to these limits, the resolution may be improved with higher quadrature count rates. Since the input pulses are counted over a gate period of 16.132ms, the resolution can be calculated using the following equations:

Encoder with Quadrature Counting enabled

$$\text{Resolution} = \frac{92\,983.2}{\text{RPM} \times N} \%$$

Encoder without Quadrature Counting (no direction information)

$$\text{Resolution} = \frac{371\,933}{\text{RPM} \times N} \%$$

Frequency pulse train input

$$\text{Resolution} = \frac{619\,888}{F_{\max}} \%$$

Example

A 1024 quadrature encoder on a 1500 RPM motor would give a resolution of:

$$\frac{92983.2}{1500 \times 1024} = 0.06\%$$

b3.09	Select frequency reference	R-W
Range	0 or 1	Default
		0

Set at 1 to select frequency reference applied to pin 4 of CON 2.

This disables the RUN, STOP and FWD/REV keys.

This page is deliberately blank

11.9 Menu 4 — Current limits and torque control

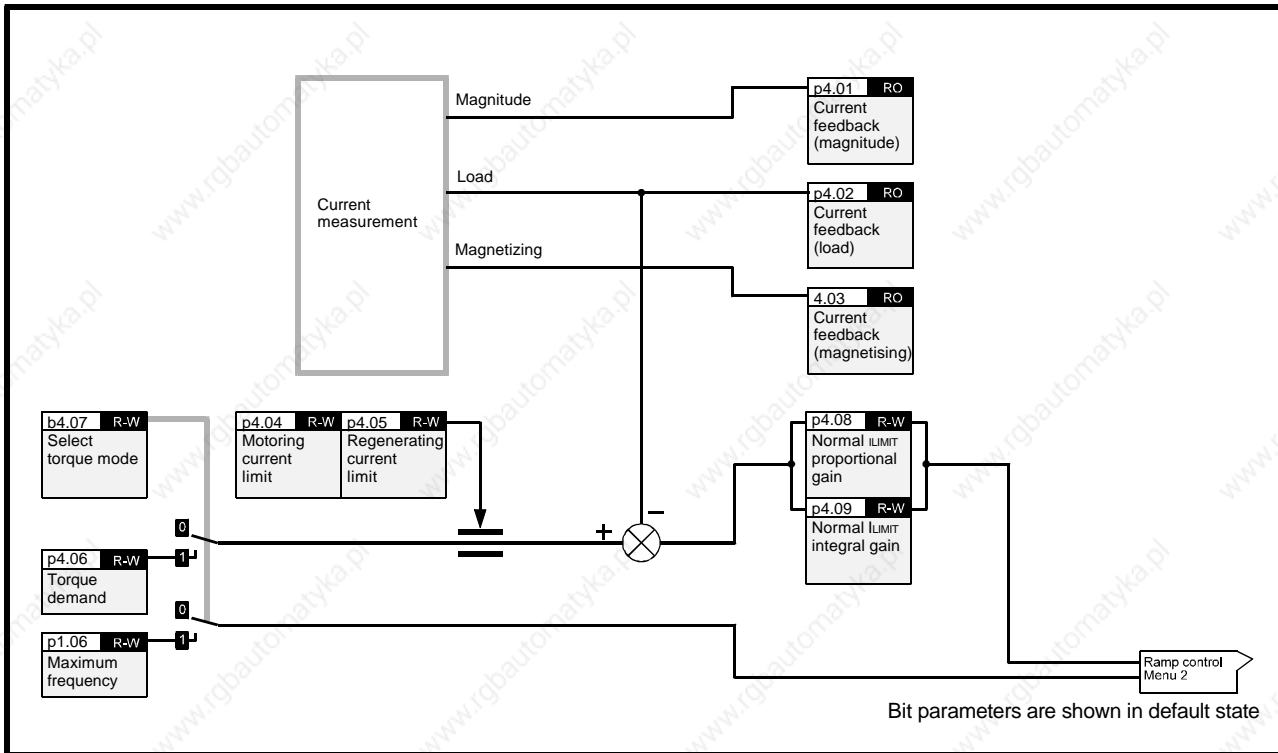

Note

For controlling read–write parameters and for displaying read-only parameters, refer to the following:

- Menu 7 — Analog inputs and outputs
- Menu 8 — Programmable digital inputs
- Menu 9 — Programmable digital outputs

p4.01	Current feedback (magnitude)	RO
Range	0 to $\pm p11.35$ A	Default

Indicates the magnitude of the total motor current.

p4.02	Current feedback (load)	RO
Range	0 to $\pm p11.35$ A	Default

Indicates the magnitude of the torque-producing motor current.

p4.03	Current feedback (magnetizing)	RO
Range	0 to $\pm p11.35$ A	Default

Indicates the magnitude of the magnetizing motor current.

p4.04	Motoring current limit	R–W
Range	0 to $\frac{p11.35}{p5.06} \times 100$ %	Default
		150

Normal current limit.

See parameter **p5.06**.

Current control and scaling

Current levels in the Drive are as follows:

OIAC

The trip level for instantaneous over-current (trip OIAC) is equivalent to the full-scale feedback level. The maximum RMS value of a sine-wave that could be produced without causing a trip would be:

$$\text{Full scale} \div \sqrt{2}$$

This is approximately twice the maximum current limit for the Drive.

Peak limit

The peak limit prevents transient peaks in motor current (torque-producing and magnetizing) from exceeding a specific level.

The Drive accommodates transient peaks in current by modifying the output voltage. This occurs only when the output voltage is below the maximum for the Drive.

The maximum RMS value of a sinusoidal output current that should occur with the peak limit operating is given by:

$$O_{IAC} \times (2000 / 2660) \div \sqrt{2}$$

(This is approximately 1.5 times the maximum current limit for the Drive).

Normal current limit

The normal current limit modifies the output frequency of the Drive in order to control the output current level. This operates at a lower level than the peak limit and is not as fast as the peak limit.

When the Drive is operating correctly, the normal current limit should normally be sufficient to control the Drive current, and the peak limit should rarely operate.

The maximum current limit is defined in parameter **p11.35**. The normal current limit controls only the torque-producing current in the motor and not the magnetizing current.

Rated torque-producing current

This is nominally the motor rated current $\times \cos\phi$. The Drive can deliver a torque-producing current of 1.2 or 1.5 times the rated level before the normal current limit operates.

p4.05 Regenerating current limit			R-W
Range	0 to $\frac{p11.35}{p5.06} \times 100$ %	Default	150

Normal current limit.

See parameter **p5.06**.

p4.06 Torque demand			R-W
Range	0 to $\frac{p11.35}{p5.06} \times 100$ %	Default	0

Defines bipolar torque demand.

In torque-control mode, the torque produced by the motor is controlled by modification of the Drive output frequency using the PI controller. This controller uses the same P and I terms as the current limits set in parameters **p4.08** and **p4.09**.

Below rated frequency, the torque demand is converted to torque-producing current.

Above rated frequency, the current is increased (to a maximum of 4 times) to compensate for the reduction of flux in the motor.

p4.06 is subject to normal current limits.

When the torque controller is used above rated frequency, set lower gains. Lower motor flux levels cause a larger change in torque-producing current for a given change of frequency.

See parameter **p5.06**.

b4.07 Select torque mode			R-W
Range	0 or 1	Default	0

Set **b4.07** at **0** for speed control mode.

When **b4.07** is set at 1, the torque reference is applied to the current controller. The PID controller uses the same P and I terms as the current limits defined in **p4.08** and **p4.09**.

It is possible to change between torque control and frequency control when the Drive is running without causing transient frequency changes.

p4.08	Normal I_{limit}	Proportional gain	R-W	
Range	0 to 99.99	% of max.	Default	0.40

The current limits operate when torque-producing current is above the current limits entered in **p4.04** and **p4.05**.

The PI controller attempts to change the output frequency to reduce torque-producing current. If a motoring load overloads the motor, it will stall. If the motor is overloaded with a regenerative load, it will accelerate to maximum frequency.

The ramp time will have an effect. The gains of the PI controller must be sufficiently high to cancel the effects of the ramps. Shorter ramp times will require higher gains.

Normally, only the P term is necessary for satisfactory operation.

p4.09	Normal I_{limit}	Integral gain	R-W	
Range	0 to 99.99	% of max.	Default	0.00

The current limits operate when torque-producing current is above the current limits entered in **p4.04** and **p4.05**

The PI controller attempts to change the output frequency to reduce torque-producing current. If a motoring load overloads the motor, it will stall. If the motor is overloaded with a regenerative load, it will accelerate to maximum frequency.

The ramp time will have an effect. The gains of the PI controller must be sufficiently high to cancel the effects of the ramps. Shorter ramp times will require higher gains.

Normally, only the P term is necessary for satisfactory operation.

p4.10	Torque output			RO
Range	Max p5.06	% of max	Default	

Indicates torque in the motor as % of rated torque.

Below rated frequency, the torque output is equal to the torque-producing current relative to $i_{torq rated}$.

Above rated frequency, the torque is compensated to allow for the reducing flux in the motor.

p4.11	Symmetrical current limit		R-W	
Range	0 to $\frac{p11.35}{p5.06} \times 100$	%	Default	150

Symmetrical current limit works in Motoring and regenerating. The lowest value of **p4.04**, **p4.05** and **p4.11** will be the effective value.

After having set the required value of maximum current in **p5.06**, you may increase or decrease the percentage overload current using **p4.11**. The maximum percentage that can be set is limited by the overload current rating of the Drive. The limit applies when motoring and regenerating.

The value of **p4.11** is automatically reduced when the value of **p5.06** is increased beyond the default value.

This page is deliberately blank

11.10 Menu 5 — Motor control

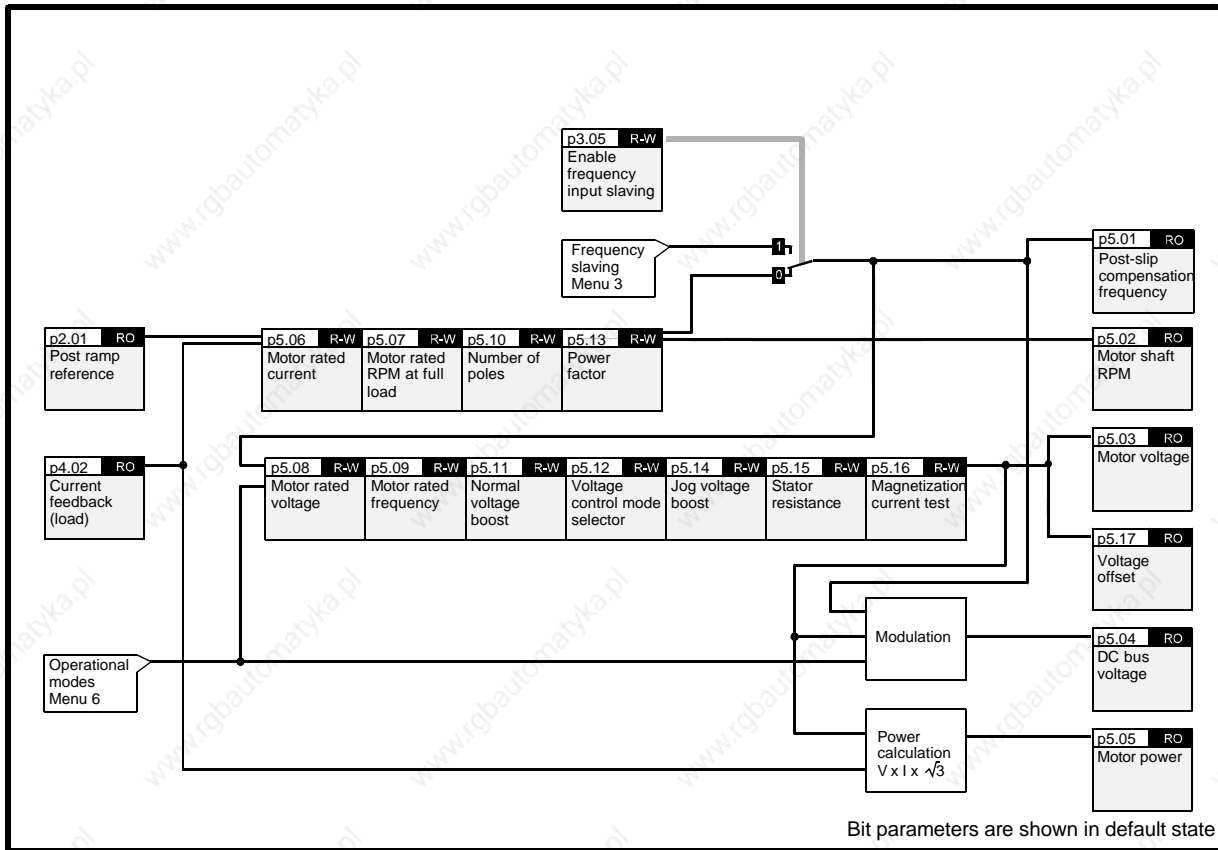

Note

For controlling read–write parameters and for displaying read-only parameters, refer to the following:

- Menu 7 — Analog inputs and outputs
- Menu 8 — Programmable digital inputs
- Menu 9 — Programmable digital outputs

p5.01	Post-slip compensation frequency	RO
Range	±p1.06 Hz	Default

Final frequency applied to the motor after the effects of current limits and slip compensation.

p5.02	Motor shaft RPM	RO
Range	0 to 9999 RPM	Default

Indicates motor shaft RPM.

The number of poles must be entered correctly in **p0.18 (p5.10)** and the slip compensation correction must not be at the maximum frequency limit (if the motor is to run at 50Hz, set **p1.06** at a higher value to allow for slip compensation).

p5.03	Motor voltage	RO
Range	±0 to p5.08 V _{RMS}	Default

Indicates the RMS voltage applied to the motor

p5.04	DC bus voltage	RO
Range	0 to 810 (CDE) 0 to 460 (CDLE)	V Default

Indicates the DC bus voltage.

p5.05	Motor power	RO
Range	kW	Default

Indicates the real component of the power output ($V \cos\phi$).

p5.06	Motor rated current			R-W
Range	0 to p11.33	A	Default	11.33

Parameters **p5.06** (motor rated current) and **p5.13** (power factor) are used by the Drive to determine the rated torque producing current ($i_{torq\ rated}$) for the Drive.

When parameter **p5.06** is set at a value lower than the default rating of the Drive, the maximum current of the Drive can be greater than 1.5 times the motor rating. Consequently, the maximum value of current limit and torque parameters (**p4.04**, **p4.05**, **p4.06**, **p4.11**, and **p6.04**) can be increased proportionately.

For example, if a 110 Amp Drive has parameter **p5.06** set at 55 Amps, the maximum values of parameters **p4.04**, **p4.05**, **p4.11** and **p6.04** can be 300% ($2 \times 150\%$). This allows larger Drives to be used for a high starting torque.

When the value is increased beyond the default value of **p5.06**, the value of **p4.11** is automatically decreased.

$$I_{torque} = p5.06 \times p5.13$$

The value entered affects the following:

- Slip compensation
- Dynamic V/f
- Ixt detection level

Industrial and HVAC applications

Industrial applications benefit from a higher percentage of overload current, but have a lower nominal current. HVAC applications benefit from a higher nominal current, but have a lower percentage of overload current (typically 120%). The overload current has the same value in each case. See parameter **p5.18**.

p5.07	Motor rated RPM at full load			R-W
Range	0 to 9999	rpm	Default	0

Enter the value from the motor rating plate. This is used by the Drive to apply correct slip compensation. If no slip compensation is required, set **p5.07** at **0** (default).

p5.08	Motor rated voltage			R-W
Range	100 to 480	V _{RMS}	Default	400 (EUR) 240 (CDLE) 460 (USA)

Enter the value from the motor rating plate in order to define the maximum output voltage of the Drive.

Parameter p5.08 must be programmed with the value given on the motor rating plate. This informs the Drive of the maximum voltage that should be applied to the motor.

The Drive controls the output voltage to give a linear voltage-to-frequency characteristic from 0Hz to the motor rated frequency, and from 0V to the motor rated voltage. (This characteristic can be modified by voltage boost or stator resistance compensation.)

Since the Drive compensates for variations in DC bus voltage, the resulting voltage from the voltage-to-frequency characteristics does not change with DC bus voltage (ie. there is no change when the Drive is braking).

Note that, even with a perfect supply, it is not possible to obtain an output voltage greater than the supply voltage when motoring.

When the required voltage exceeds the maximum possible output level (dependent on the supply) or the rated voltage (set by the user), the frequency can still be increased, but the motor enters the constant-power or field-weakening region.

Whatever value of motor rated voltage is entered, the Drive output will contain high frequency switching components having peak voltage levels related to the DC bus voltage level, not to the motor rated voltage. Consequently, when a motor of low voltage is used, the high-frequency switching components at the Drive output may stress the windings.

p5.09	Motor rated frequency			R-W
Range	10.0 to 999.9	Hz	Default	50 (EUR) 60 (USA)

Enter a value of frequency at which the rated voltage is to be applied to the motor. The motor then enters the constant-power or field-weakening region.

p5.10	Number of poles			R-W
Range	2p [0] (2 poles) 4p [1] (4 poles) 6p [2] (6 poles) 8p [3] (8 poles)	Default	4p [1]	

Enter the value from the motor rating plate for correct slip compensation and RPM indication

p5.11	Normal voltage boost			R-W
Range	0 to 25.5	% of p5.08	Default	3.0

The voltage boost defines the nominal level of boost at 0Hz as a percentage of the rated voltage (**p5.08**). Voltage boost is applied only when one of the boost modes is selected (see parameter **p5.12**). The figure below shows fixed boost.

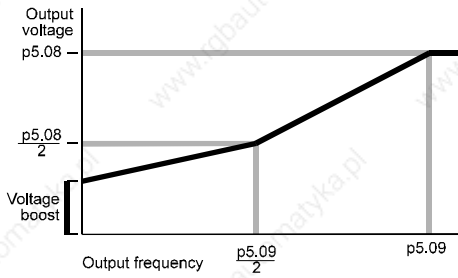

p5.12 Voltage control mode selector		R-W	
Range	0 to 4	Default	Ur_I [3]
Auto	[0]	Auto boost	
Fd	[1]	Fixed boost	
Ur_S	[2]	Vector mode. Stator resistance is measured at power-up or start	
Ur_I	[3]	Vector mode. Stator resistance is measured at power-up only	
Ur	[4]	Vector mode. Stator resistance is not measured	

Above 25% of rated frequency, a linear voltage-to-frequency characteristic normally produces sufficient torque. Below this frequency, voltage boost may be required in order to maintain the torque.

The voltage control mode selector is used to select the required type of voltage boost at low frequencies and the conditions for measuring stator resistance.

Mode 0 – Auto boost

Auto boost automatically controls the voltage boost with load. If the level is set too high, the motor can become over-fluxed, and the boost can become 'latched' at a high level.

With high inertia loads at low speed, the Drive may trip when decelerating the motor to a stop. This will result in the motor coasting to a stop.

The level of boost is determined from the value in parameter **p5.11** (voltage boost) which is then modified so that:

$$\text{Auto boost} = \text{Voltage boost} \times i_{\text{torq}} / i_{\text{torq rated}}$$

Mode 1 – Fixed boost

Fixed boost can give high levels of current when starting and stopping, but can result in over-fluxing of the motor on light loads.

Mode 2 – Vector mode with stator resistance measurement at start

Mode 3 – Vector mode with stator resistance measurement at power up

Mode 4 – Vector mode with no stator resistance measurement

Vector mode is intended for operation with a single motor and gives reasonable control of the motor flux with different loads, since the voltage-to-frequency characteristic is modified according to the load inertia. (Closed-loop current control is not used.)

The voltage-to-frequency characteristic is based on the following motor parameters:

- Magnetizing current
- Stator resistance

Good control of the magnetizing current (and hence motor flux) extends down to:

$$\text{Rated frequency} \div 50$$

(ie. value of parameter **p5.09** \div 50)

The parameters required for this mode can be derived by the Drive during the magnetizing current measurement.

Measuring stator resistance

This measurement can be performed automatically under the following conditions:

- When AC power is connected to the Drive (**Ur_I** mode)
- When a START command is given to the Drive (**Ur_S** mode)

The second condition (**Ur_S**) is recommended because stator resistance can change with temperature.

The measured value is stored in parameter **p5.15**, along with a voltage offset related to the IGBT voltage drops and other effects in the Drive (**p5.17**).

When AC power is disconnected from the Drive, the power factor and stator resistance are automatically stored.

When **Ur_I** mode is selected, the voltage is based on previously measured values (in **Ur_I** mode, the stator resistance is not measured). The voltage offset (which is usually quite small) is not saved when AC power is removed, so this fine correction of the voltage applies only when **Ur_S** or **Ur_I** modes are used.

Note

The results of the stator resistance measurement (but not the magnetizing current measurement) are to some extent dependent on the switching frequency and modulation technique being used. Good control at low speed can be maintained only when the switching frequency and space vector modulation (see Menu 6) are not changed after the stator resistance has been measured.

p5.13	Power factor				R-W
Range	0.30 to 1.00	cos ϕ	Default	0.85	

Saved at power down.

Refer to **p5.16** for automatic calculation of power factor. Refer also to the warning.

p5.13 is used with **p5.06** to calculate the conversion level between current and torque producing current.

$$i_{\text{torque rated}} = \mathbf{p5.06} \times \mathbf{p5.13}$$

p5.14	Jog voltage boost				R-W
Range	0 to 25.5	% of p5.08	Default	3.0	

Enter a different percentage boost for Jog when **p5.11** is used.

p5.15	Stator resistance measurement				R-W
Range	0 to 9.999	Ω	Default	0	

Saved at power down.

This is used for Vector mode compensation. See parameter **p5.12**.

p5.16	Magnetizing current test				R-W
Range	0 to 9999		Default	0	

Automatically saved.

Measuring the magnetizing current

Warning

The motor runs at half maximum speed while this measurement is performed.

This measurement can be carried out with the motor on- or off-load. If the measurement is to be carried out on-load, a reasonable estimate of the power factor of the motor (which relates to the magnetising current) must first be given to the Drive. In most cases, the default value will be sufficiently close to that of the motor. If it is not, enter in parameter **p5.13** the figure for the power factor of the motor.

Use the following procedure:

1. Ensure the Drive is stopped.
2. Set **p5.16** at **255**.
3. Ensure that a trip is not active.
4. Apply a continuous signal to the STOP input (Do not activate the START input).
5. Press the STOP-RESET button or apply a momentary signal to the RESET input (pin 4 of CON 3) to reset the Drive.

Note

The measurement should now be carried out. If it is not carried out (eg. because the STOP input is not active) the measurement is cancelled. To try again, repeat the preceding instructions.

6. The power factor parameter **p5.13** is now updated with the value calculated during the measurement.

Ensure the stop switch is closed.

Set 5.16 at 255 to start the test.

Reset the Drive to enter the new value of power function in p5.13.

p5.17	Voltage offset				RO
Range	0 to 1536		Default		

Indicates the voltage offset measured during stator resistance measurement.

p5.18	Overload time				R-W
Range	0 to 60	s	Default	60	

Enter a value for the required duration of maximum overload current.

When the Drive is used with motors having a relatively low power rating, the motor could be damaged by the overload current of the Drive. To protect such motors, the value of parameter **p5.18** can be reduced to reduce the time that the overload current is produced. The default value of **p5.18** is 60 seconds.

11.11 Menu 6 — Operational modes

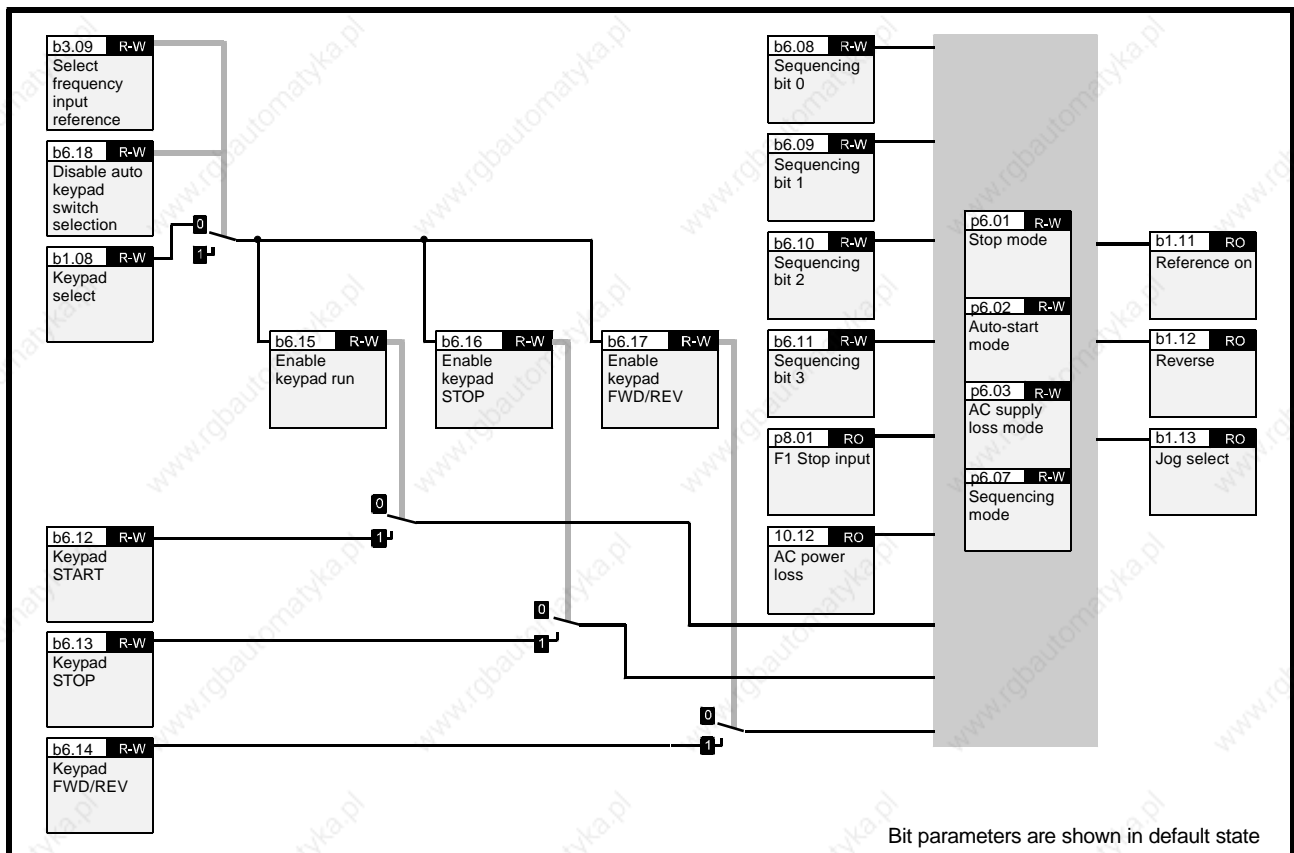

Note

For controlling read–write parameters and for displaying read-only parameters, refer to the following:

- Menu 7 — Analog inputs and outputs
- Menu 8 — Programmable digital inputs
- Menu 9 — Programmable digital outputs

p6.01		Stop mode		R–W
Range	[0] to [4]	Default	rp [0]	
rP	[0]	The Drive ramps to zero speed		
inh	[1]	Inhibit (coast to stop)		
dc	[2]	DC injection braking		
rP.dc	[3]	Ramp + DC injection braking		
td.dc	[4]	Timed DC injection braking		

Parameter **p6.01** controls the stopping mode. Stopping occurs in two phases, as follows:

- Phase 1: Decelerating to stop
- Phase 2: Drive stopped

The settings are as follows:

Mode [0] — Ramp mode

The Drive ramps to zero speed during the first phase, and then waits for one second in the second phase to ensure the motor has completely stopped before disabling the output.

Mode [1] — Inhibit mode

The output is disabled as soon as a STOP command is received, and the motor coasts to rest. The first phase consists of a two-second delay before the Drive can be restarted. There is no activity in the second phase.

Mode [2] — DC injection braking

Mode [3] — Ramp plus DC injection braking

Mode [4] — Timed DC injection braking

In all these modes, the second phase consists of injection of DC current for at least one second at the level entered in parameter **p6.04**. This ensures the motor is completely at rest before the Drive output is disabled. The first phase of Mode [3] is the same as that for Mode [0].

In Modes [2] and [4], injection braking uses low-frequency current at a level programmed in parameter **p6.04** during the deceleration phase. In Mode [2] this allows the Drive to detect when the motor has reached a low speed, so the injection time is adjusted automatically to suit the motor and the load. In Mode [4], the time for decelerating to a stop must be programmed in parameter **p6.05**.

In Mode [2] only, when a stop is initiated, the Drive monitors the motor to detect when the speed reaches 5Hz so phase 2 can be initiated. If the injection current is too low, the detection system does not operate and the motor rotates continuously at a low frequency.

The minimum level of current required is normally between 70% and 80% of the rated current of the motor.

Once stopping in Mode [2] or [4] has begun, it can be terminated by the motor stopping, or the occurrence of a trip. In this case, the Drive must be stopped before it can be re-started.

p6.02 Auto-start mode			R-W
Range	[0] to [2]	Default	diS [0]
diS	[0]	The Drive does not start when AC power is applied	
ALYS	[1]	The Drive always starts when AC power is applied	
Pd.dP	[2]	The Drive starts only if it had been running when AC power was previously removed.	

The Auto-start modes are as follows:

The Auto-start modes define the behaviour of the Drive when AC power is applied.

Mode [0] – Disabled

The Drive will not automatically start when AC power is applied.

Mode [1] – Always

The Drive always starts irrespective of the state before AC power was removed. The STOP input switch must be closed.

Mode [2] – Power-down dependent

The Drive starts only if it had been running when AC power was removed. The STOP input switch must be closed.

p6.03 AC supply loss mode			R-W
Range	[0] to [2]	Default	rd.th [2]
dis	[0]	Disabled	
Stop	[1]	Stop when AC supply is lost	
rd.th	[2]	Ride-through short interruptions	

The AC supply loss modes are as follows:

Mode [0] – Disabled

Loss of AC power is not detected. The Drive continues to operate unchanged only while the DC bus remains within specification. When the voltage is below specification, the Drive ceases to control the motor.

Mode [1] – Stop mode

Mode [2] – Ride-through mode

When loss of AC power is detected, the Drive decelerates at a rate to return sufficient power from the motor to the DC bus in order to supply the control circuits. Since the PID loop for the Standard-controlled ramp (see parameter **p2.02**) is used for this function, adjustment of the PID gains (**p2.29** to **p2.31**) may be necessary for the feature to operate correctly. In this case, the PID controller attempts to force the DC bus voltage to 700V for the CDE models (380V for the CDLE models) and then hold it constant by changing the Drive output frequency.

Normally, the DC bus voltage can be held at a fixed level with a PI controller. If the motor is heavily loaded when AC power is lost, the frequency must be reduced quickly to prevent the DC bus voltage from reducing below specification.

The D term will operate for 250ms after loss of AC power in order to improve the response. The D term is stopped after this point, since it can make the control loop unstable if it continues in operation.

The ramp rate is controlled by the PID controller, and is at least as fast as the deceleration ramp for a normal stop.

In order to help reduce the frequency quickly, slip compensation is disabled when loss of AC power is detected (this will have no effect if no slip compensation has been programmed).

When AC power is restored and Stop mode is selected, the Drive continues to decelerate until the machine stops. When Ride-through mode is selected, the motor accelerates to its normal running speed.

p6.04	Injection braking level		R–W
Range	0 to $\frac{p11.35}{p5.06} \times 100$ % of FLC	Default	150

If the injection braking level is set too low the Drive will not stop. If a low injection level is required, use the timed **DC** injection **td.dc** by setting **p0.12** at [4]

p6.05	Injection braking time		R–W
Range	0.5 to 25.5	Default	5.0

When **p6.01** is set at 4, enter the required deceleration time.

p6.06	Switching frequency		R–W
Range	[0] or [1]	Default	3kHz [0]
	3 [0] 3kHz		
	6 [1] 6kHz (Model size 1 only)		

p6.07	Sequencing mode		R–W
Range	[0] to [3]	Default	[0]
	CD type interface [0]		
	Mentor type interface [1]		
	Wire-proof interface [2]		
	PLC interface [3]		

b6.08	Sequencing bit [0]		R–W
b6.09	Sequencing bit [1]		
b6.10	Sequencing bit [2]		
b6.11	Sequencing bit [3]		
Range	0 or 1	Default	0

CD type sequencing mode [0]

		CON 3 default pin number
Sequencing bit 0	Run (latching)	3
Sequencing bit 1	Jog	6
Sequencing bit 2	Reverse	7
Sequencing bit 3	Not used	

When Keypad mode is enabled, sequencing bit 0 can be over-riden by the RUN key and sequencing bit 2 can be over-riden by the FWD–REV key.

Mentor type sequencing mode [1]

		CON 3 default pin number
Sequencing bit 0	Run forward (latching)	3
Sequencing bit 1	Jog forward	6
Sequencing bit 2	Run reverse (latching)	7
Sequencing bit 3	Jog reverse	

When Keypad mode is enabled, the RUN key can also start the Drive, and the FWD–REV key can change the direction (unless one of the sequencing bit signal is being held, in which case the sequencing bits have priority). Jog states always over-ride Run.

Wire-proof mode sequencing mode [2]

		CON 3 default pin number
Sequencing bit 0	Run forward	3
Sequencing bit 1	Jog	6
Sequencing bit 2	Run reverse	7
Sequencing bit 3	Not used	

For the Drive to run, parameter **p10.24** (Drive reset), parameter **p8.01** (Stop input), and sequencing bit 0 or 2 must be set at 1. When **p10.24** is set at 0, the Drive is disabled.

To Jog forward or reverse, the Jog sequencing bit must be set at 1, together with the appropriate direction sequencing bit. Pressing the RUN, STOP and FWD–REV keys has no effect.

PLC mode sequencing mode [3]

		CON 3 default pin number
Sequencing bit 0	Run	3
Sequencing bit 1	Jog	6
Sequencing bit 2	reverse	7
Sequencing bit 3	Not used	

Read-only parameter **b8.01** (Stop input) indicates that the Drive is enabled or disabled. When **b8.01** = 0, the Drive is disabled.

Sequencing bit 0 must be set at 1 for the Drive to run. When sequencing bit 0 is set at 0 the Drive stops.

Because this mode requires signals to be continuously applied to the control signal terminals for the Drive to run, the **run**, **stop**, and **fwd/rev** keys are inactive.

b6.12	Keypad START	R–W	
b6.13			
b6.14			
Range	0 or 1	Default	0

When a key is pressed the related parameter is set at 1.

b6.15	Enable Keypad RUN	R–W	
b6.16			
b6.17			
Range	0 or 1	Default	0

Use these parameters to enable or disable individual keys of the Control Keypad.

When **p6.18** is set at 0 and **b1.08** (Keypad reference) is set at 1, these parameters are automatically set at 1.

The Control Keypad is disabled when **b3.09** is set at 1.

b6.18	Disable auto keypad switch selection	R–W	
Range	0 or 1	Default	0

Set at 1 to disable control using the Control Keypad.

b6.19	Dynamic V/f	R–W	
Range	0 or 1	Default	0

Set **p6.19** at 1 for the rated frequency to change depending on Drive load current.

$$\text{Rated frequency} = \mathbf{p5.09} \times (2 - (|i_{\text{torq}}| / 0.7i_{\text{torq rated}}))$$

$$\text{for } |i_{\text{torq}}| < 0.7i_{\text{torq rated}}$$

(**p5.09** = Motor rated frequency)

where i_{torq} is the value of torque-producing current and $i_{\text{torq rated}}$ is the rated level of torque-producing current derived from **p5.06** (motor rated current) and **p5.13** (power factor).

$$i_{\text{torq rated}} = \mathbf{p5.06} \times \mathbf{p5.13}$$

b6.20	Enable high-stability space vector modulation	R–W	
Range	0 or 1	Default	0

Set at 0 for normal space vector modulation.

Set at 1 for high-stability space vector modulation. This is a special case of space vector modulation which results in each phase being clamped to one or other of the DC bus rails in the Drive for $1/6$ th of a cycle of the fundamental output. This gives the following advantages:

Lightly-loaded 50Hz induction motors supplied by variable speed drives can go unstable at frequencies between 10Hz and 30Hz. High-stability space vector modulation prevents this instability.

At the transition to pulse-dropping (see **b6.21**), instability can be caused especially on lightly-loaded machines. High-stability space vector modulation reduces this effect.

High-stability space vector modulation has the disadvantage that unwanted voltage components result in more acoustic noise than when using other techniques.

For normal and high-stability types of modulation, dead-time compensation is used. This should help to reduce instability when normal space vector modulation is used in the 10Hz to 30Hz range.

b6.21	Enable quasi-square wave output	R–W	
Range	0 or 1	Default	0

When **b6.21** is set at 1, **p5.08** still defines the V/f characteristic but the voltage will continue to rise above the motor rated voltage. The Drive becomes over-modulated until pulse-dropping occurs and a square-wave is produced. The resultant harmonics can produce high peak currents and cause high levels of acoustic noise in the motor.

b6.22	Disable forward rotation	R–W	
Range	0 or 1	Default	0

Set at 1 to prevent the Drive producing forward rotation of the motor (except when frequency slaving).

b6.23	Disable reverse rotation	R–W	
Range	0 or 1	Default	0

Set at 1 to prevent the Drive producing reverse rotation of the motor (except when frequency slaving).

b6.24	Catch spinning motor			R-W
Range	0 or 1	Default	0	

Set **b6.24** at 1 to select this feature.

The Drive performs a sequence of tests to determine the motor frequency before attempting to apply full voltage to the motor. To limit the motor current, the tests are carried out at a reduced voltage set in **p6.34** of the required voltage.

The Drive frequency is first set at maximum (set in **p1.06**) in the direction in which the Drive last ran. The frequency is then ramped to zero over a period entered in **p6.33** and compared with the motor frequency.

If the motor frequency is not detected, the frequency is set at maximum in the other direction and the test is repeated. When the frequency is detected, the test is stopped and the Drive starts at the detected frequency and takes control of the motor.

If the motor frequency is not detected at all, the Drive starts at 0Hz.

If the Drive is powered-down, the previous direction of rotation is not stored, so the test begins in the forward direction.

p6.25	Enable motorized potentiometer zero start			R-W
Range	0 or 1	Default	0	

When **p6.25** is set at 1, and AC power is applied to the Drive, the motorized potentiometer output is set at zero.

When **p6.25** is set at 0, and AC power is applied to the Drive, the motorized potentiometer output returns to the level that existed when AC power was previously removed.

p6.26	Motorized potentiometer rate			R-W
Range	5 to 255	s/ 100%	Default	20

The value in parameter **p6.26** defines the time taken for the motorized potentiometer function to ramp from 0 to 100.0%. Twice this time will be taken to adjust the output from -100.0% to +100.0%.

p6.27	Motorized potentiometer up			R-W
p6.28	Motorized potentiometer down			
Range	0 or 1	Default	0	

To control these motorized potentiometer parameters, two digital inputs must be programmed. Apply signals to these inputs to control the up and down functions.

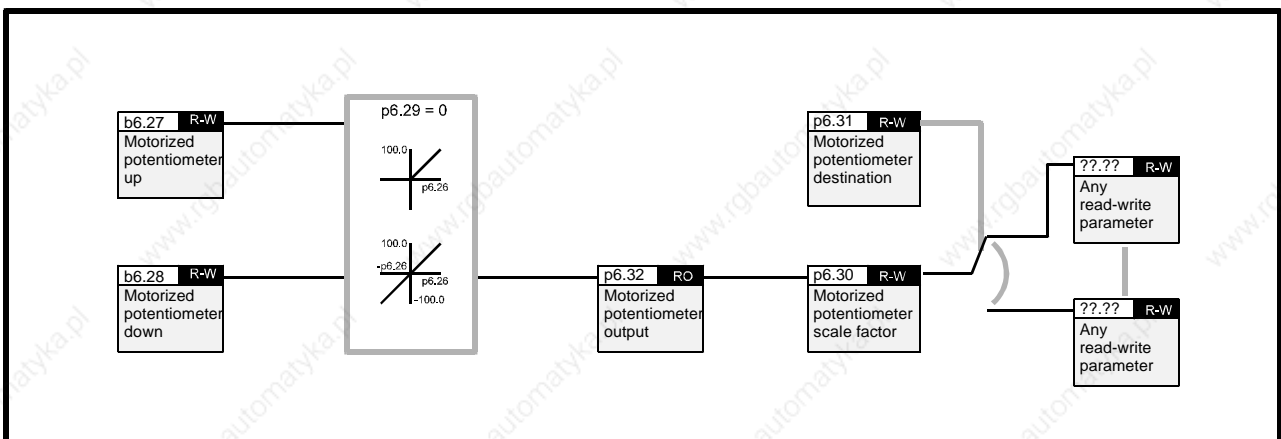

Figure 11-2 Motorized potentiometer logic diagram

p6.29	Bipolar motorized potentiometer	R-W
--------------	--	-----

Range	0 or 1	Default	0
-------	--------	---------	---

Set **p6.29** at 1 to allow the motorized potentiometer to go negative, otherwise the output remains positive only.

p6.30	Motorized potentiometer scale factor	R-W
--------------	---	-----

Range	0.000 to 9.999	Default	1.000
-------	----------------	---------	-------

This parameter can be used to restrict the output of the motorized potentiometer to operate over a reduced range so that it can be used as a trim, for example.

p6.31	Motorized potentiometer destination	R-W
--------------	--	-----

Range	0.00 to 17.50	Default	0
-------	---------------	---------	---

Reset the Drive to make active.

Program the destination parameter that the motorized potentiometer is to control. If the motorized potentiometer is to control speed, it is suggested that one of the preset speed parameters is entered in **p6.31**. If the motorized potentiometer is to trim speed, it is suggested that **p1.15** (offset parameter) is entered in **p6.31**.

p6.32	Motorized potentiometer output	RO
--------------	---------------------------------------	----

Range	±100.00	%	Default	
-------	---------	---	---------	--

Saved at power down.

This parameter indicates the current level of the motorized potentiometer. The value is saved when AC power is removed from the Drive.

p6.33	Spin start ramp time	R-W
--------------	-----------------------------	-----

Range	2.0 to 25.5	secs	Default	10
-------	-------------	------	---------	----

Time taken to ramp down from maximum frequency (**p1.06**) to 0 Hz while the Drive attempts to synchronize itself with a spinning motor. Change the value for applications that require the Drive to be caught in a shorter or longer time.

p6.34	Spinning motor scan voltage	R-W
--------------	------------------------------------	-----

Range	0 to 100	%	Default	25
-------	----------	---	---------	----

When the Drive is in normal operation, the rated motor voltage varies with frequency. When the Drive is attempting to synchronize itself to a spinning motor, a percentage of this varying voltage is applied to the motor. The value entered in parameter **p6.34** determines this percentage.

If the value is too low, the motor may not be detected during the scan. If the value is too high, the Drive may trip on **OIAC** or **OV**.

11.12 Menu 7 — Analog inputs and outputs

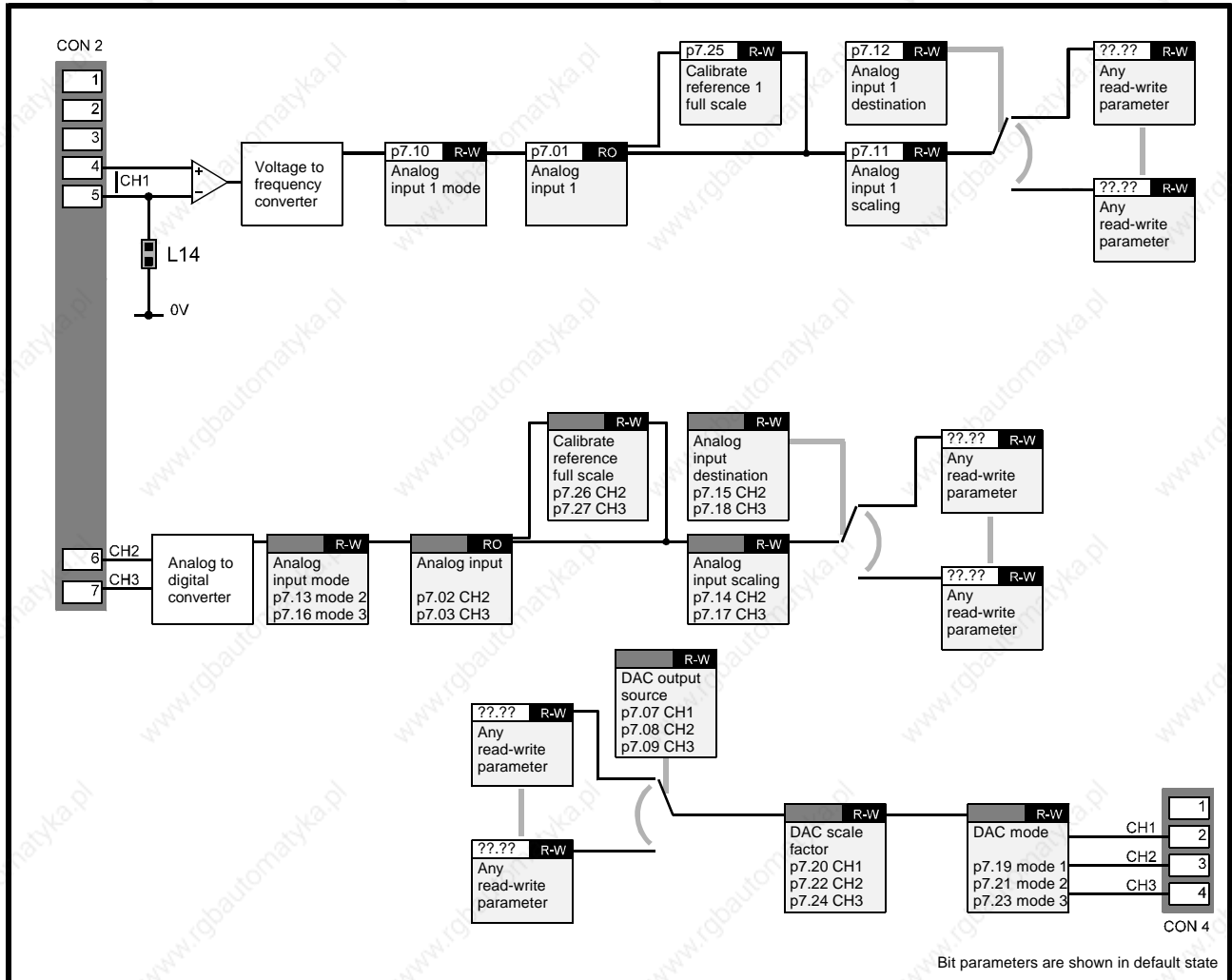

Bit parameters are shown in default state

p7.01	Analog input 1			RO
Range	±100% for voltage input.	%	Default	

Displays the amplitude of the signal applied to Analog input 1.

Resolution: 12-bit plus sign
Updated every 5.3ms

p7.02	Analog Input 2			RO
Range	±100% for voltage input. 0 to 100% for current input.	%	Default	

Displays the amplitude of the signal applied to Analog input 2.

Resolution: 10-bit plus sign
Updated every 5.3ms

p7.03	Analog input 3			RO
Range	±100% for voltage input. 0 to 100% for current input	%	Default	

Displays the amplitude of the signal applied to Analog input 3.

Resolution: 10-bit plus sign
Updated every 5.3ms

p7.04	Stack temperature			RO
Range	0 to 94	°C	Default	

Indicates the temperature of the heatsink.

At 94°C, the Drive will trip on over-temperature.

The Drive can be reset when the temperature falls to 90°C.

p7.05	Ambient temperature			RO
Range	0 to 80	°C	Default	80

At 80°C, the Drive will trip.

The Drive can be reset when the temperature falls to 75°C.

p7.06	AC supply voltage			RO
Range	340 to 530 (CDE)	V _{RMS}	Default	
	200 to 260 (CDLE)			

Indicates RMS voltage of the AC supply.

p7.07	Analog output 1 source			R–W
p7.08	Analog output 2 source			
p7.09	Analog output 3 source			
Range	p0.00 to p17.50	XX.XX	Default	p5.03 p4.02 p5.01

Enter the parameter number that is required to supply a value to Analog output 1. A bit parameter cannot be programmed to appear on this analog output.

p7.10	Analog input 1 mode			R–W
Range	[0] to [8]	Default	Voltage	

Reset the Drive to make active.

Refer to Chapter 5 *Setting Jumpers* for selecting voltage and current input and output signals.

Set	Display	Mode	
[0]	VOLT	Voltage input	
[1]	0–20	0 – 20 mA	
[2]	20–0	20 – 0 mA	
[3]	4–20	4 – 20 mA	Trip on current loop loss
[4]	20–4	20 – 4 mA	Trip on current loop loss
[5]	4–20.	4 – 20 mA	Min speed on current loop loss
[6]	20–4.	20 – 4 mA	Min speed on current loop loss
[7]	4–2.0	4 – 20 mA	Last speed on current loop loss
[8]	20–.4	20 – 4 mA	Last speed on current loop loss

p7.16 has the following additional mode settings:

[9]	th	Thermistor with trip on detection of short-circuit
[10]	th	Thermistor without detection of short-circuit

In 4–20mA and 20–4mA operation, the threshold for current-loop loss is 3mA.

Analog inputs are sampled every 5.3ms except in the special case where a voltage input is programmed to one of the analog reference parameters **p1.19** and **p1.20**, and that parameter is selected as the reference. In this case, the sample rate is increased to 750Hz.

Bit parameters, read-only parameters and some other sensitive parameters cannot be controlled using the analog inputs.

p7.11	Analog input 1 scaling			R–W
Range	0 to 9.999	Default	1.000	

Enter a value to scale Analog input 1.

Note

In most cases, adjustment of **p7.11**, **p7.14** and **p7.17** is not necessary since the inputs are automatically scaled so that 100% input signal sets the destination parameter at maximum.

p7.12	Analog input 1 destination			R–W
Range	p0.00 to p17.50	XX.XX	Default	p1.19

Reset the Drive to make active.

Enter the parameter that Analog input 1 is to control.

p7.13	Analog input 2 mode			R–W
Range	[0] to [8]	Default	4 to 20	

Reset the Drive to make active. See parameter **p7.10**.

p7.14	Analog input 2 scaling			R–W
Range	0 to 9.999	Default	1.000	

Enter a value to scale Analog input 2.

See parameter **p7.11**.

p7.15	Analog input 2 destination			R–W
Range	p0.00 to p17.50	XX.XX	Default	p1.20

Reset the Drive to make active.

Enter the parameter that Analog input 2 is to control.

p7.16	Analog input 3 mode			R–W
Range	[0] to [10]	Default	VOLT [0]	

Reset the Drive to make active.

See parameter **p7.10**.

p7.17	Analog input 3 scaling			R–W
Range	0 to 9.999	Default	1.000	

Enter a value to scale Analog input 3.

See parameter **p7.11**.

p7.18	Analog input 3 destination	R-W
Range	p0.00 to p17.50 XX.XX	Default 0

Reset the Drive to make active.

Enter the parameter that Analog input 3 is to control.

p7.19	Analog output 1 mode	R-W
Range	[0] to [2]	Default Volt [0]

Parameter **p7.19** together with jumper LK11 on the IN82 circuit board can be used to configure Analog output 1 in three modes as follows:

Mode		
[0]	VOLT	Output range: $\pm 10V$
[1]	0-20	Output range: 0 – 20 mA
[2]	4-20	Output range: 4 – 20 mA

In Modes 1 and 2, negative values in the source parameter are treated as zero.

Analog outputs are derived from PWM signals having a carrier frequency of 2kHz. The PWM signals are passed through a second-order filter with a corner frequency of 50Hz.

The analog outputs are updated every 16ms.

p7.20	Analog output 1 scale factor	R-W
Range	0 to 9.999	Default 1.000

Enter a value to scale Analog output 1.

Note

In most cases, adjustment of **p7.20**, **p7.22** and **p7.24** is not necessary since the output is automatically scaled so that 100% output signal is produced when the source parameter is at maximum.

p7.21	Analog output 2 mode	R-W
Range	[0] to [2]	Default Volt [0]

Parameter **p7.21** together with jumper LK12 on the IN82 circuit board can be used to configure Analog output 2 in three modes as follows:

Mode		
[0]	VOLT	Output range: $\pm 10V$
[1]	0-20	Output range: 0 – 20 mA
[2]	4-20	Output range: 4 – 20 mA

In Modes 1 and 2, negative values in the source parameter are treated as zero.

p7.22	Analog output 2 scale factor	R-W
Range	0 to 9.999	Default 1.000

Enter a value to scale Analog output 2.

p7.23	Analog output 3 mode	R-W
Range	[0] to [2]	Default Volt [0]

Parameter **p7.23** together with jumper LK13 on the IN82 circuit board can be used to configure Analog output 1 in three modes as follows:

Mode		
[0]	VOLT	Output range: $\pm 10V$
[1]	0-20	Output range: 0 – 20 mA
[2]	4-20	Output range: 4 – 20 mA

In Modes [1] and [2], negative values in the source parameter are treated as zero.

p7.24	Analog output 3 scale factor	R-W
Range	0 to 9.999	Default 1.000

Enter a value to scale Analog output 3.

b7.25	Calibrate reference 1 full scale	R-W
b7.26	Calibrate reference 2 full scale	
b7.27	Calibrate reference 3 full scale	
Range	0 or 1	Default 0

Set at 1 when the full scale signal applied to Analog input 1, 2 or 3 is less than 10V. The Drive then automatically adjusts the scale factor.

b7.25, **b7.26**, **b7.27** is reset to 0 when the calibration is complete.

This page is deliberately blank

11.13 Menu 8 — Programmable digital inputs

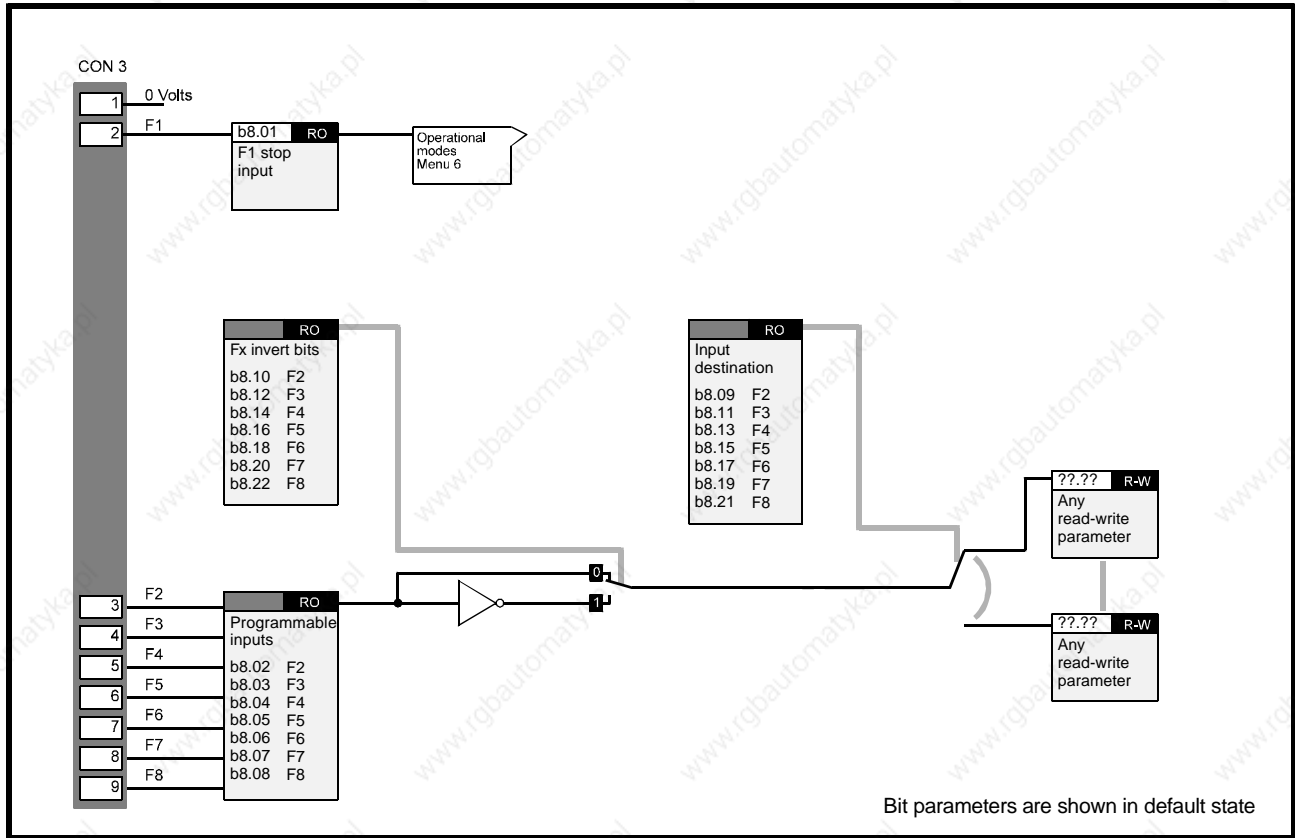

b8.01	F1 Stop input	RO
b8.02	F2 programmable input	
b8.03	F3 programmable input	
b8.04	F4 programmable input	
b8.05	F5 programmable input	
b8.06	F6 programmable input	
b8.07	F7 programmable input	
b8.08	F8 programmable input	
Range	0 or 1	Default

Bit parameters **b8.01** to **b8.08** indicate the logic states of the programmable digital inputs **F1** to **F8** as follows:

- 0 = Inactive (logic 0)
- 1 = Active (logic 1)

The **input destination** parameters (**b8.09**, etc) define the parameter that the related programmable input (**F2**, etc) is to control.

The **invert** parameters (**b8.10**, etc) can be used to invert the logic state of the destination parameter.

The programmable digital inputs are sampled every 10.6ms.

Variable parameters, read-only parameters and Keypad control parameters (**p6.12** to **p6.14**) cannot be controlled by the programmable digital inputs.

p8.09	F2 input destination	R-W
Range	p0.00 to p17.50 XX.XX	Default 6.08

Reset the Drive to make active.

Enter the parameter number to use as the destination for input F2.

Default: Sequencing bit 0 (run).

b8.10	F2 invert	R-W
Range	0 or 1	Default 0

Set at 1 to invert the logic sense of F2.

p8.11	F3 input destination	R-W
Range	p0.00 to p17.50 XX.XX	Default 10.24

Reset the Drive to make active.

Enter the parameter number to use as the destination for input F3.

Default: Reset.

b8.12	F3 invert		R-W
Range	0 or 1	Default	0

Set at 1 to invert the logic sense of F3.

p8.13	F4 input destination		R-W
Range	p0.00 to p17.50 XX.XX	Default	10.29

Reset the Drive to make active.

Enter the parameter number to use as the destination for input F4.

Default: Trip Et.

b8.14	F4 invert		R-W
Range	0 or 1	Default	0

Set at 1 to invert the logic sense of F4.

p8.15	F5 input destination		R-W
Range	p0.00 to p17.50 XX.XX	Default	6.09

Reset the Drive to make active.

Enter the parameter number to use as the destination for input F5.

Default: Sequencer bit 1 (log).

b8.16	F5 invert		R-W
Range	0 or 1	Default	0

Set at 1 to invert the logic sense of F5.

p8.17	F6 input destination		R-W
Range	p0.00 to p17.50 XX.XX	Default	6.10

Reset the Drive to make active.

Enter the parameter number to use as the destination for input F6.

Default: Sequencer bit 2 (Reverse).

b8.18	F6 invert		R-W
Range	0 or 1	Default	0

Set at 1 to invert the logic sense of F6.

p8.19	F7 input destination		R-W
Range	p0.00 to p17.50 XX.XX	Default	1.21

Reset the Drive to make active.

Enter the parameter number to use as the destination for input F7.

Default: Analog reference 2 select (Remote).

b8.20	F7 invert		R-W
Range	0 or 1	Default	0

Set at 1 to invert the logic sense of F7.

p8.21	F8 input destination		R-W
Range	p0.00 to p17.50 XX.XX	Default	p1.08

Reset the Drive to make active.

Enter the parameter number to use as the destination for input F7.

Default: Control Keypad select.

b8.22	F8 invert		R-W
Range	0 or 1	Default	0

Set at 1 to invert the logic sense of F8.

11.14 Menu 9 — Programmable digital outputs

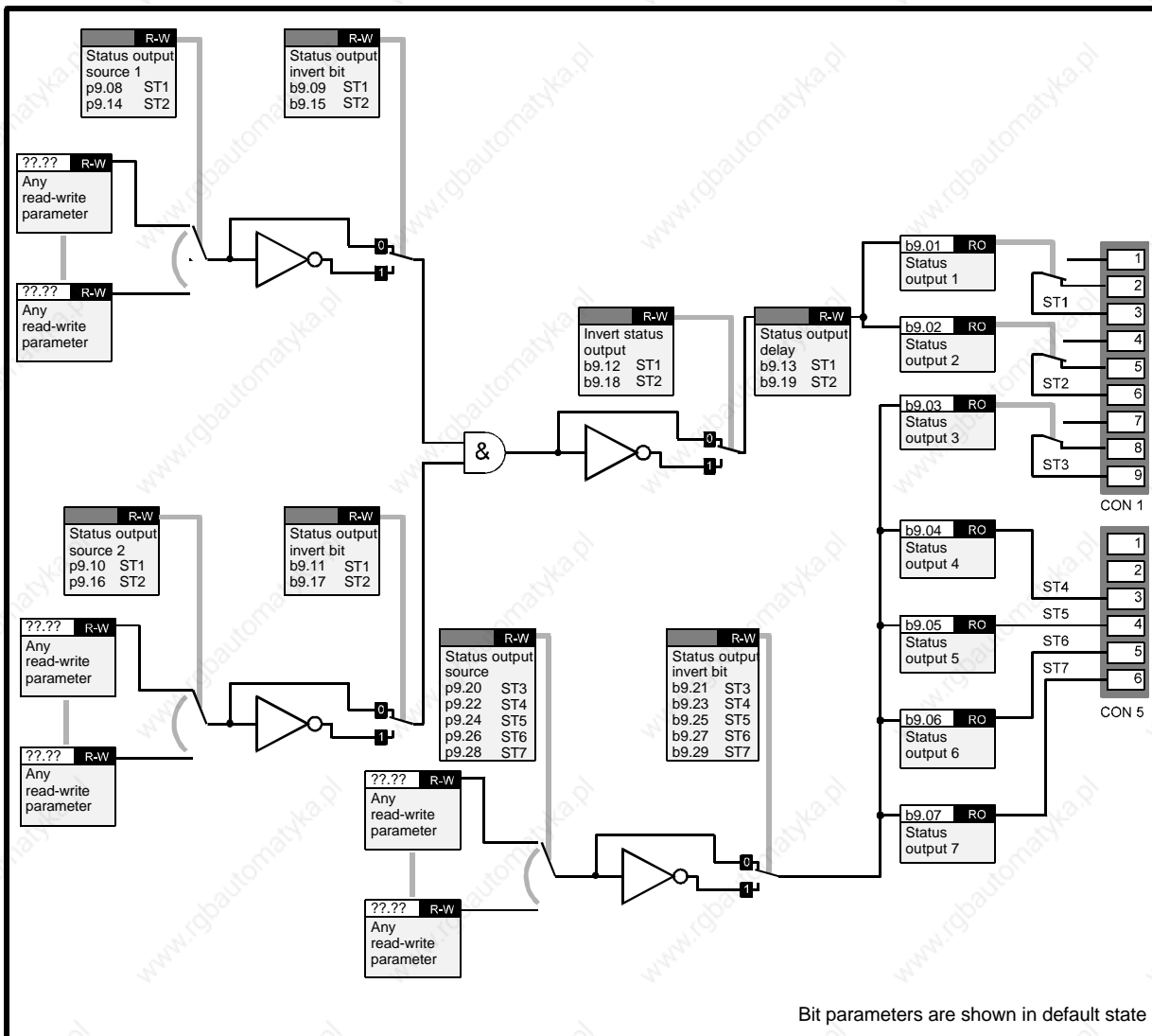

Bit parameters are shown in default state

b9.01	Status output 1 (relay)	RO
b9.02	Status output 2 (relay)	
b9.03	Status output 3 (relay)	
b9.04	Status output 4	
b9.05	Status output 5	
b9.06	Status output 6	
b9.07	Status output 7	
Range	0 or 1	Default 0

The **Status output** parameters monitor the logic states of the seven Status outputs. The outputs and these parameters are updated every 10.6ms.

Variable parameters cannot be used as a source for the Status outputs.

(If variable parameters need to be used see Programmable thresholds Menu 12.)

p9.08	Status output 1, Source 1	R-W
Range	p0.00 to p17.50 XX.XX	Default b10.04

Enter the bit parameter number to be used as Source 1 for Status output 1.

The default setting indicates when the Drive is at or below minimum frequency.

b9.09	Status output 1, Source 1 invert	R-W
Range	0 or 1	Default 0

Set at 1 to invert the logic state of Source 1 of Status output 1.

p9.10	Status output 1 source 2		R-W
Range	p0.00 to p17.50 XX.XX	Default	0

Enter the bit parameter number to be used as Source 2 for Status output 1.

b9.11	Status output 1, Source 2 invert		R-W
Range	0 or 1	Default	0

Set at 1 to invert the logic state of Source 2 of Status output 1.

b9.12	Status output 1 Invert		R-W
Range	0 or 1	Default	0

Set at 1 to invert the logic state of Status output 1.

b9.13	Status output 1 delay		R-W
Range	0 to 25.5 s	Default	0

Enter a value for the required delay for Status output 1 to become active (logic 1). The delay is used to ensure that the output condition is genuine by being present for a period of time.

The delay does not operate when the state changes to logic 0.

p9.14	Status output 2, Source 1		R-W
Range	p0.00 to p17.50 XX.XX	Default	b10.02

Enter the bit parameter number to be used as Source 1 for Status output 2.

The default setting indicates when the Drive is in the **RUN** state.

b9.15	Status output 2, Source 1 invert		R-W
Range	0 or 1	Default	0

Set at 1 to invert the logic state of Source 1 of Status output 2.

p9.16	Status output 2, Source 2		R-W
Range	p0.00 to p17.50 XX.XX	Default	0

Enter the bit parameter number to be used as Source 2 for Status output 2.

b9.17	Status output 2, Source 2 invert		R-W
Range	0 or 1	Default	0

Set at 1 to invert the logic state of Source 2 of Status output 2.

b9.18	Status output 2 Invert		R-W
Range	0 or 1	Default	0

Set at 1 to invert the logic state of Status output 2.

p9.19	Status output 2 delay		R-W
Range	0 or 25.5 s	Default	0

Enter a value for the required delay for Status output 2 to become active (logic 1). The delay is used to ensure that the output condition is genuine by being present for a period of time.

The delay does not operate when the state changes to logic 0.

p9.20	Status output 3, Source		R-W
Range	p0.00 to p17.50 XX.XX	Default	b10.01

Enter the bit parameter number to be used as the source for Status output 3.

The default setting indicates **Drive normal**.

b9.21	Status output 3 invert		R-W
Range	0 or 1	Default	0

Set at 1 to invert the logic state of Status output 3.

p9.22	Status output 4, Source		R-W
Range	p0.00 to p17.50 XX.XX	Default	b10.05

Enter the bit parameter number to be used as the source for Status output 4.

The default setting indicates when the Drive is **At speed**.

b9.23	Status output 4 invert		R-W
Range	0 or 1	Default	0

Set at 1 to invert the logic state of Status output 4.

p9.24	Status output 5, Source		R-W
Range	p0.00 to p17.50	XX.XX	Default b10.08

Enter the bit parameter number to be used as the source for Status output 5.

The default setting indicates when the Drive is in **Current limit**

b9.25	Status output 5 invert		R-W
Range	0 or 1	Default	0

Set at 1 to invert the logic state of Status output 5.

p9.26	Status output 6 source		R-W
Range	p0.00 to p17.50	XX.XX	Default b10.13

Enter the bit parameter number to be used as the source for Status output 6.

The default setting indicates when **Forward direction** is demanded.

b9.27	Status output 6 invert		R-W
Range	0 or 1	Default	0

Set at 1 to invert the logic state of Status output 6.

p9.28	Status output 7 source		R-W
Range	p0.00 to p17.50	XX.XX	Default b10.06

Enter the bit parameter number to be used as the source for Status output 7.

The default setting indicates **load reached**.

b9.29	Status output 7 invert		R-W
Range	0 or 1	Default	0

Set at 1 to invert the logic state of Status output 7.

11.15 Menu 10 — Status logic and diagnostic information

b10.01	Drive normal		RO
Range	0 or 1	Default	0

b10.01 = 0 indicates the Drive is tripped.

b10.01 = 1 indicates the Drive is normal (not tripped), or if **b10.28** = 1 the Drive is tripped but an auto-reset is going to occur.

b10.02	Drive running		RO
Range	0 or 1	Default	0

b10.02 = 1 indicates the output bridge of the Drive is active.

b10.03	Zero frequency or stopped		RO
Range	0 or 1	Default	

b10.03 = 1 indicates the ramp output is between -1Hz and +1Hz.

b10.04	Running at or below minimum frequency		RO
Range	0 or 1	Default	

In bipolar mode (**b1.10** set at 1), **b10.04** is in the same state as **b10.03** (zero frequency).

In unipolar mode (**b1.10** set at 0), **b10.04** = 1 when the Drive is running and the ramp output is between: [+min freq.+ 1Hz] or [-min freq.-1Hz].

b10.05	At speed		RO
Range	0 or 1	Default	

When the Drive is running **b10.05** = 1 indicates the ramp output is within 1Hz of the selected speed reference.

b10.06	Load reached		RO
Range	0 or 1	Default	0

b10.06 = 1 indicates:

$$i_{\text{torq_rated}} \geq \text{Rated load current}$$

$$i_{\text{torq_rated}} = p5.06 \times p5.13$$

b10.07	Alarm		RO
Range	0 or 1	Default	105%

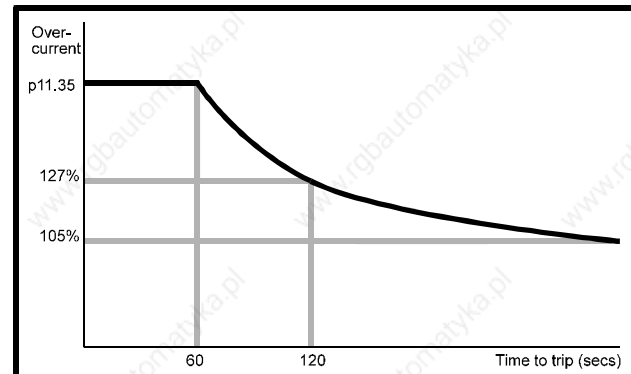

Figure 11-3 Time to trip is dependent on the extent of current overload

b10.07 = 1 indicates that motor current is greater than 105% of the programmed motor rated current. If the current is not reduced, the Drive will trip on **lxt** overload after a period of time that depends on the extent of the overload. For example:

$$\text{Motor current} = p11.35 - \text{Time to trip} = 60 \text{ secs maximum}$$

$$\text{Motor current} = \frac{(p11.35 - 105\%)}{2} - \text{Time to trip} = 120 \text{ secs maximum}$$

b10.08	Drive output is at current limit		RO
Range	0 or 1	Default	0

b10.08 = 1 indicates the normal current limit is active.

b10.09	Motor regenerating		RO
Range	0 or 1	Default	0

b10.09 = 1 indicates the output bridge is transferring power from the motor to the DC bus.

b10.10	Dynamic brake active		RO
Range	0 or 1	Default	0

b10.10 = 1 indicates power is being dissipated in the optional DC braking resistor (if fitted).

b10.11	Serial communications active		RO
Range	0 or 1	Default	0

b10.11 = 1 indicates successful communication is taking place.

b10.12	Loss of AC power		RO
Range	0 or 1	Default	0

b10.12 = 1 indicates loss of AC power to the Drive.

b10.13	Forward rotation commanded		RO
Range	0 or 1	Default	0

b10.13 = 1 indicates the pre-ramp reference is positive.

p10.14	Last trip		RO
p10.15	Last trip but 1		
p10.16	Last trip but 2		
p10.17	Last trip but 3		
p10.18	Last trip but 4		
p10.19	Last trip but 5		
p10.20	Last trip but 6		
p10.21	Last trip but 7		
p10.22	Last trip but 8		
p10.23	Last trip but 9		
Range		Default	

These parameters indicate previous Trip codes.

b10.24	Drive reset		R-W
Range	0 or 1	Default	0

Set at 1 to reset the Drive.

If the Drive is to be reset by an input signal, a programmable digital input must be programmed to control this parameter.

b10.25	Enable auto-reset		R-W
Range	0 or 1	Default	0

Set **b10.25** at 1 for the Drive to be automatically reset when tripped after a programmed delay set in **p10.26**. The reset can be repeated to a maximum number of times programmed in **p10.27**.

p10.26	Reset delay		R-W
Range	0 to 25.5	s	Default
			1.0

When the programmed value of **p10.27** is reached, any further trips of the same type will not cause a reset. A trip of a different type will cause a reset.

p10.27	Number of reset attempts		R-W
Range	0 to 5	Default	0

If no trip has occurred for 10 minutes, the reset count is cleared.

Auto reset will not occur on External trip (**Et**).

b10.28	Hold Drive Normal until last attempt		R-W
Range	0 or 1	Default	0

Set at 0 to reset **b10.01** (**Drive normal** indication) every time the Drive trips, regardless of auto-resets.

Set at 1 for the **Drive normal** indication to remain set when a trip occurs and an auto-reset is going to occur.

b10.29	External trip		R-W
Range	0 or 1	Default	1

When an external trip signal is required to control this parameter, use a programmable digital input and ensure that the input state is at logic 1 to prevent the Drive tripping.

When **b10.29** = 0 the Drive will trip.

p10.30	Processor 2 trip		R-W
Range	0 to 70	Default	0

When a user-defined trip occurs and causes a command from an expansion card or serial communications to be sent to the Drive, parameter **p10.30** can be used to trip the Drive and display a relevant trip code.

The expansion card should enter a valid trip code into **p10.30**. Valid codes are **40** to **69**. The display will then show **tr40** to **tr69** accordingly. The Trip log will also show these codes.

If a standard Trip code is entered in **p10.30**, the Trip code will be shown and the Drive tripped accordingly.

The Drive can be reset by setting **p10.30** at 70.

p10.31	Status word		RO
Range	0 to 32761	Default	0

Parameter **p10.31** contains a binary coded number. This indicates the current state of the read-only parameters that indicate the status of the Drive. The coded number can be used to control indicators on a separate display panel.

The binary codes that are produced when the parameters are at logic 1 are as follows:

Parameter	Description	Binary No.
b10.01	Drive normal	2 ⁰
b10.02	Drive running	2 ¹
b10.03	Zero frequency or stopped	2 ²
b10.04	Running at or below minimum frequency	2 ³
b10.05	At speed	2 ⁴
b10.06	Load reached	2 ⁵
b10.07	Alarm	2 ⁶
b10.08	Drive output is at current limit	2 ⁷
b10.09	Motor regenerating	2 ⁸
b10.10	Dynamic brake active	2 ⁹
b10.11	Serial communications active	2 ¹⁰
b10.12	Loss of AC power	2 ¹¹
b10.13	Forward rotation commanded	2 ¹²
b10.25	Enable Auto-reset	2 ¹³

11.16 Menu 11 — Miscellaneous parameters

Use the Menu 11 parameters in the following table to assign parameters in the Advanced menus to the User menu (Menu 0). The default assignments are shown. The Menu 11 parameters in the table are read–write.

Parameter number	Menu 0 User parameter	Default assignment
p11.01	p0.01	p1.06
p11.02	p0.02	p2.03
p11.03	p0.03	p2.04
p11.04	p0.04	p4.11
p11.05	p0.05	p5.06
p11.06	p0.06	p5.12
p11.07	p0.07	p5.07
p11.08	p0.08	p6.04
p11.09	p0.09	p5.08
p11.10	p0.10	p4.07
p11.11	p0.11	p6.02
p11.12	p0.12	p6.01
p11.13	p0.13	p1.04
p11.14	p0.14	p5.16
p11.15	p0.15	p6.06
p11.16	p0.16	p6.24
p11.17	p0.17	p1.14
p11.18	p0.18	p5.10
p11.19	p0.19	p4.02
p11.20	p0.20	p5.02

For read-only parameters programmed into **p11.19** and **p11.20**, a scale factor can be applied using **p11.21** and **p11.22** in order to indicate some meaningful unit such as cans-per-hour.

p11.21 Scale factor for p0.19			R–W
Range	0.0 to 9.999	Default	1.000

Enter a value to scale **p0.19** to represent a meaningful unit, such as cans per hour.

p11.22 Scale factor for p0.20			R–W
Range	0.0 to 9.999	Default	1.000

Enter a value to scale **p0.20** to represent a meaningful unit, such as cans per hour.

p11.23 Serial address			R–W
Range	11 to 99	Default	11

Enter an address for serial communications.

Numbers ending in zero should not be used since these are used for groups of Drives.

p11.24 Serial mode [Reset drive to make active]			R–W
Range	[0] to [2]	Default	ANSI [0]

Select the required mode of operation for serial communications.

ANSI [0] ANSI protocol, half-duplex serial communications

outP [1] Output variable defined by **p11.31**

inP [2] Input variable to parameter defined by **p11.31**.

Parameter **p11.24** selects the serial communications mode. Modes 1 and 2 are used for transfer of data from one Drive to another. In both these cases, data is transferred at a rate of 200Hz. Although the data rate is slightly slower than that for a Mentor II Drive, the protocol and Baud rate are identical. It is possible to connect a CDE Drive to a Mentor II Drive for data transfer in either direction.

Reset the Drive after selecting a different mode, in order to make the new selection active.

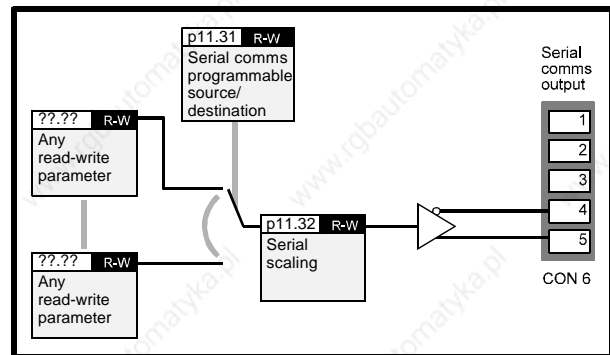

Figure 11-4 Mode 1 — Sending a parameter value to another Drive

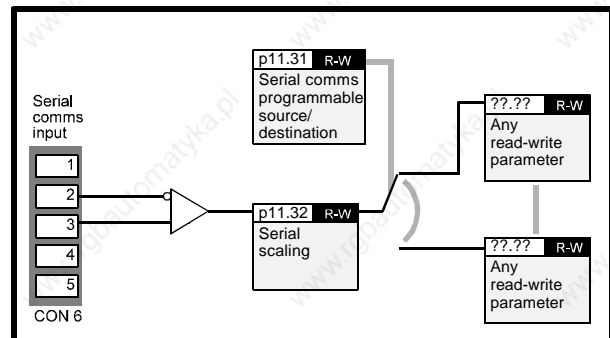

Figure 11-5 Mode 2 — Receiving a parameter value from another Drive

In the event of the Drive tripping, a value of zero is transmitted.

Once data has been received in Mode 2, a serial-communications-loss trip will occur if serial communications are lost and the last data received is not zero.

p11.25	Baud rate		R-W
Range	[0] to [2]	Default	4800 [0]
	4,800 baud	[0]	
	9,600 baud	[1]	
	19.2 kbaud	[2]	

p11.26	2-wire mode		R-W
Range	0 or 1	Default	0

Set at 1 to allow 2-wire serial communications.

Set at 0 for 4-wire serial communications.

p11.27	Software version		RO
Range	XX.XX	Default	

Indicates version of software in the Drive.

p11.28	Processor 2 software version		RO
Range	XX.XX	Default	

Indicates software version present on any optional card fitted.

p11.29	Level 3 security code		R-W
Range	0 to 255	Default	149

Enter a number other than 149 to apply Level 3 security.

See Chapter 10 Security.

p11.30	Parameter to be displayed when AC power is applied		R-W
Range	p0.00 to p0.20	XX.XX	Default
			0.20

Enter the number of the parameter that is to be displayed when AC power is applied.

p11.31	Serial communications programmable source/destination		R-W
Range	p0.00 to p17.50	XX.XX	Default
			0

Reset the Drive to make active.

Enter the number of the parameter to be sent or received using serial communications Modes [1] and [2] respectively.

In Mode [2], reset the Drive to make a new selection active.

See parameter **p11.24**.

p11.32	Serial scaling		R-W
Range	0.0 to 9.999	Default	1.000

Enter a scaling value for data sent or received in serial communications Modes [1] and [2] respectively.

In most cases, it is not necessary to apply scaling since input and output values are automatically scaled.

p11.33	Current rating		RO
Range		Default	

Indicates maximum continuous current rating in Amps of the Drive.

p11.34	Voltage rating		RO
Range	0 to 1	Default	

Indicates the voltage rating of the Drive.

cdLE (CDLE) [0] Low voltage range
 cdE (CDE) [1] Standard voltage range.

p11.35	Overload rating		RO
Range	21 to 2880	Default	

Indicates maximum overload current in Amps of the Drive.

11.17 Menu 12 — Programmable thresholds

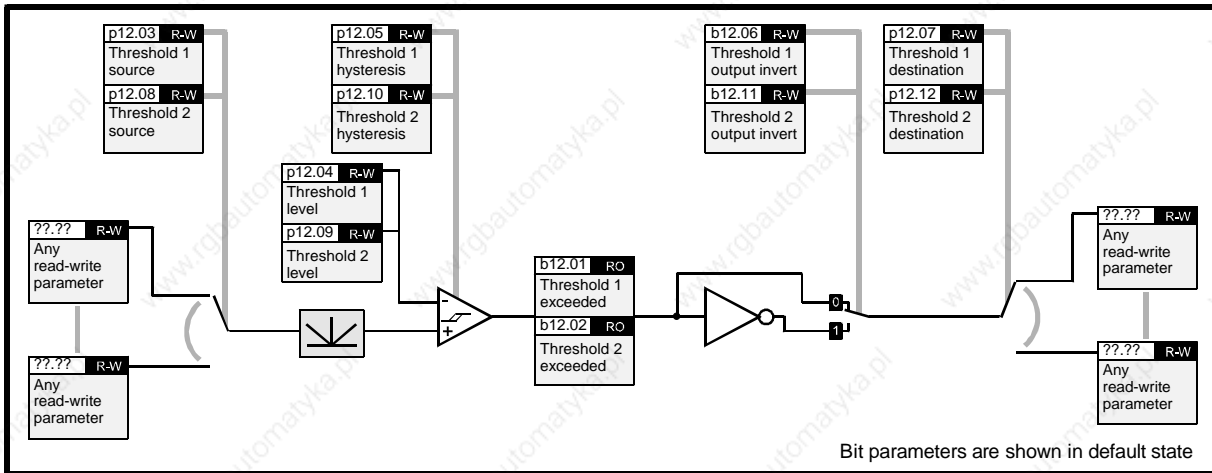

b12.01	Threshold 1 exceeded			RO
---------------	-----------------------------	--	--	----

Range	[0] or [1]	Default		
-------	------------	---------	--	--

b12.01 = 1 indicates input variable is above Threshold 1
b12.01 = 0 indicates input variable is below Threshold 1

b12.02	Threshold 2 exceeded			RO
---------------	-----------------------------	--	--	----

Range	[0] or [1]	Default		
-------	------------	---------	--	--

b12.02 = 1 indicates input variable is above Threshold 2
b12.02 = 0 indicates input variable is below Threshold 2

p12.03	Threshold 1 source			R-W
---------------	---------------------------	--	--	-----

Range	p0.00 to p17.50	XX.XX	Default	0
-------	-----------------	-------	---------	---

Enter the number of the parameter to be used as the source for threshold 1. The absolute value of the source is taken as the input to the Threshold comparator. Reset the Drive to make active.

p12.04	Threshold 1 level			R-W
---------------	--------------------------	--	--	-----

Range	0.0 to 100.0	%	Default	0
-------	--------------	---	---------	---

User-defined threshold 1 level entered as a percentage of the source maximum.

p12.05	Threshold 1 hysteresis			R-W
---------------	-------------------------------	--	--	-----

Range	0 to 25.5	%	Default	0
-------	-----------	---	---------	---

Defined band where no change will occur to the comparator output.

Upper limit for switching: Level + [hyst ÷ 2]
 Lower limit: Level – [hyst ÷ 2]

b12.06	Threshold 1 output invert			R-W
---------------	----------------------------------	--	--	-----

Range	[0] or [1]	Default		0
-------	------------	---------	--	---

Set at 1 to invert threshold comparator 1 output.

p12.07	Threshold 1 destination			R-W
---------------	--------------------------------	--	--	-----

Range	p0.00 to p17.50	XX.XX	Default	0
-------	-----------------	-------	---------	---

Reset the Drive to make active

Define the destination of threshold comparator 1 output. The destination must be a R-W bit parameter.

Reset the Drive to make active a new value entered in **p12.07**.

p12.08	Threshold 2 source			R-W
---------------	---------------------------	--	--	-----

Range	p0.00 to p17.50	XX.XX	Default	0
-------	-----------------	-------	---------	---

Refer to the notes for **p12.03** to **p12.07**.

p12.09	Threshold 2 level			R-W
---------------	--------------------------	--	--	-----

Range	0.0 to 100.0	%	Default	0
-------	--------------	---	---------	---

Refer to the notes for **p12.03** to **p12.07**.

p12.10	Threshold 2 hysteresis			R-W
---------------	-------------------------------	--	--	-----

Range	0 to 25.5	%	Default	0
-------	-----------	---	---------	---

Refer to the notes for **p12.03** to **p12.07**.

p12.11	Threshold 2 output invert			R-W
---------------	----------------------------------	--	--	-----

Range	[0] or [1]	Default		0
-------	------------	---------	--	---

Refer to the notes for **p12.03** to **p12.07**.

p12.12	Threshold 2 destination			R-W
---------------	--------------------------------	--	--	-----

Range	p0.00 to p17.50	XX.XX	Default	0
-------	-----------------	-------	---------	---

Reset the Drive to make active

Refer to the notes for **p12.03** to **p12.07**.

11.18 Menu 13 — Timer functions

p13.01	Run-time log			RO
Range	0.000 to 9.364	y.ddd	Default	

Saved at power down.

Indicates years and days of the total running time of the Drive

p13.02	Run-time log			RO
Range	00.00 to 23.59	hh.mm	Default	

Saved at power down.

Indicates the hours and minutes of the total running time of the Drive

p13.03	Energy consumption measurement			RO
Range	0 to 9999	MWh	Default	

Saved at power down.

Indicates MWh of energy consumed.

p13.04	Energy consumption measurement			RO
Range	000.0 to 999.9	kWh	Default	

Saved at power down.

Indicates kWh of energy consumed.

p13.05	Running cost			RO
Range	0 to XXXX	p13.08/ h	Default	

Continuously indicates the running cost/hour.
Requires the correct value to be entered in **p13.08**.

p13.06	Time remaining until filter change due			R-W
Range	0 to 9999	h	Default	

Saved at power down.

Indicates running time remaining before the system requires a change of filter.

p13.07	Time remaining until lubrication due			RO
Range	0 to 9999	h	Default	

Saved at power down.

Indicates running time remaining before the system or mechanical system requires lubrication.

p13.08	Electricity cost per kWh			R-W
Range	00.00 to 99.99	Currency	Default	0

Enter electricity cost for use by **p13.05**.

b13.09	Reset Energy Consumption meter			R-W
Range	0 or 1	Default	0	

Set at 1 to reset **p13.03** and **p13.04**.

p13.10	Time interval between filter changes			R-W
Range	0 to 9999	h	Default	0

Enter the running time the motor must operate between filter changes.

b13.11	Filter change done			R-W
Range	0 or 1	Default	1	

b13.11 is automatically set at 1 when **p13.06** = 0. Set **b13.11** at 0 when the filter is changed. This causes **p13.06** to be loaded with the value of **p13.10**.

p13.12	Time interval between lubrication			R-W
Range	0 to 9999	h	Default	0

Defines the running time the machine must operate between lubrication.

b13.13	Lubrication done			R-W
Range	0 or 1	Default	1	

b13.13 is automatically set at 1 when **p13.07** = 0. Set **b13.13** at 0 when lubrication is carried out. This causes **p13.07** to be loaded with the value of **p13.12**.

11.19 Menu 14 — PID control loop, Encoder feedback

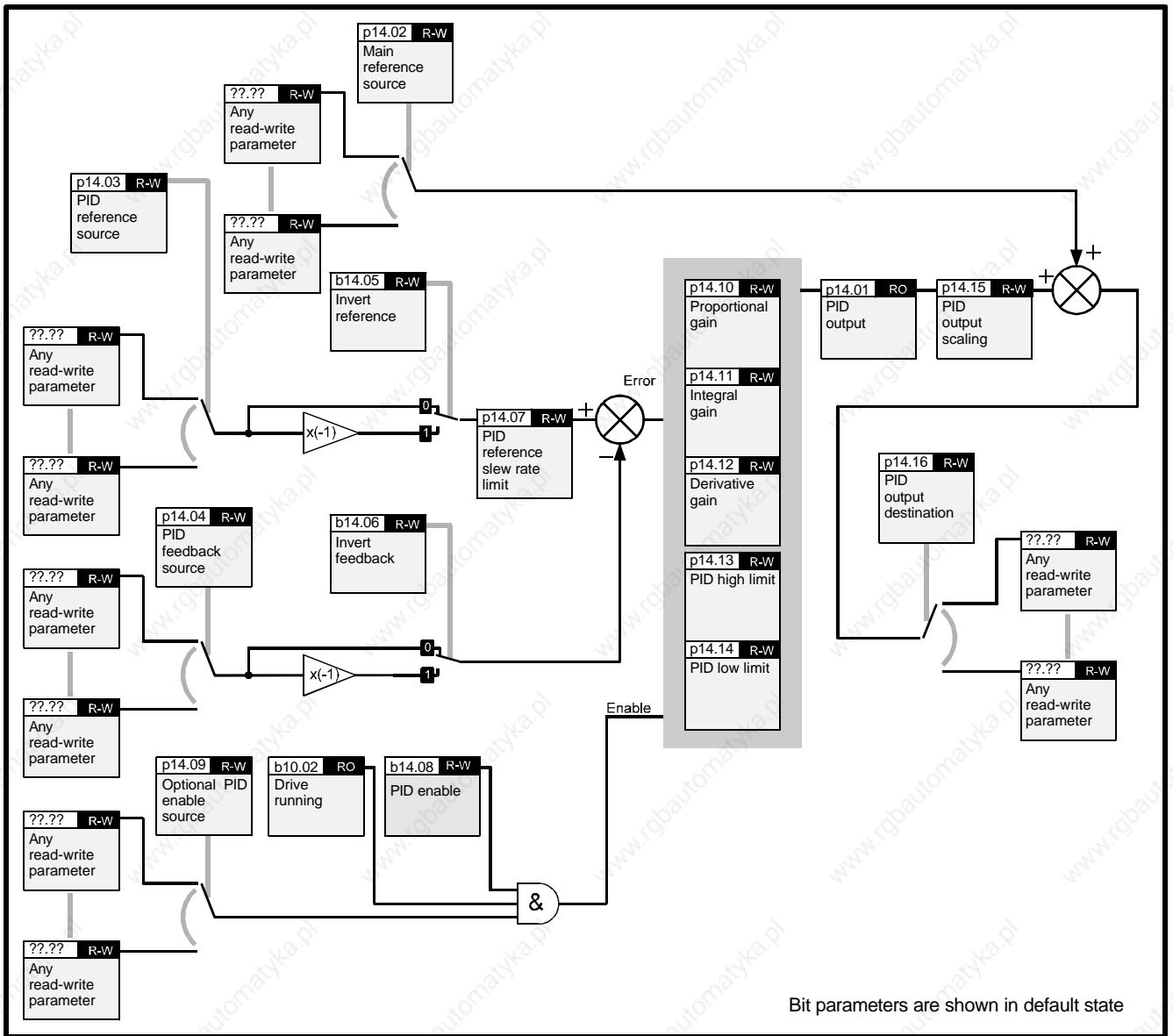

p14.01	PID output			RO
Range	±100.0	%	Default	

The inputs to the PID controller are automatically scaled to the range ±100.0%. The PID controller output is also within this range.

Although it would appear that the variables have only 10-bit resolution, internal calculations are made at a higher resolution for greater accuracy. The displayed values are scaled versions of the internal variables.

After the final addition to the main reference, the output is automatically scaled again to match the range of the destination parameter.

Gain parameters are actual units, as follows:

$$\text{PID output} = \text{Pe} + \text{Ie/s} + \text{Des}$$

where:

- P**, **I** and **D** are the programmed gains
- e** is the input error to the PID controller
- s** is the Laplace identifier

p14.02	Main reference source			R-W
Range	p0.00 to p17.50	XX.XX	Default	0.00

Reset the Drive to make active.

See parameter **p14.01**.

p14.03	PID reference source			R-W
Range	p0.00 to p17.50	XX.XX	Default	

Reset the Drive to make active.

See parameter **p14.01**.

p14.04	PID feedback source			R-W
Range	p0.00 to p17.50	XX.XX	Default	0.00

Reset the Drive to make active.

See parameter **p14.01**.

b14.05	Invert reference			R-W
Range	[0] or [1]	Default		0

See parameter **p14.01**.

b14.06	Invert feedback			R-W
Range	[0] or [1]	Default		0

See parameter **p14.01**.

b14.07	PID reference slew rate limit			R-W
Range	0.1 to 3276	Default		0.1

See parameter **p14.01**.

b14.08	PID enable			R-W
Range	[0] or [1]	Default		0

See parameter **p14.01**.

p14.09	Optional PID enable source			R-W
Range	p0.00 to p17.50	XX.XX	Default	0.00

Reset the Drive to make active.

See parameter **p14.01**.

p14.10	Proportional gain			R-W
Range	0 to 9.999	Default		1.000

See parameter **p14.01**.

p14.11	Integral gain			R-W
Range	0 to 9.999	Default		0.500

See parameter **p14.01**.

p14.12	Derivative gain			R-W
Range	0 to 9.999	Default		0

See parameter **p14.01**.

p14.13	PID high limit			R-W
Range	0 to 100.0	%	Default	100.0

See parameter **p14.01**.

p14.14	PID low limit			R-W
Range	-100.0 to +100.0	%	Default	-100.0

See parameter **p14.01**.

p14.15	PID output scaling			R-W
Range	0.000 to 9.999	Default		1.000

See parameter **p14.01**.

p14.16	PID output destination			R-W
Range	p0.00 to p17.50	XX.XX	Default	0.00

Reset the Drive to make active.

See parameter **p14.01**.

12 Serial Communications

12.1 Introduction

Serial communications can be used by a host computer or PLC to perform the following:

- Read and edit the values of parameters
- Control the Drive

One host computer may control up to 81 Drives when line buffers are used or 32 Drives without line buffers.

The serial communications format is RS485 which is a differential link that ensures a high level of immunity to noise. It also withstands high common-mode rejection. The protocol is the following industry standard:

ANSI x 3.28 – 2.5 – A4

The data format is as follows:

- 7 data bits
- 1 start bit
- 1 stop bit
- Even parity

12.2 Connecting the Drive

Two-wire or four-wire mode may be used (refer to Figure 12–1). For best reliability use screened twisted pair cable.

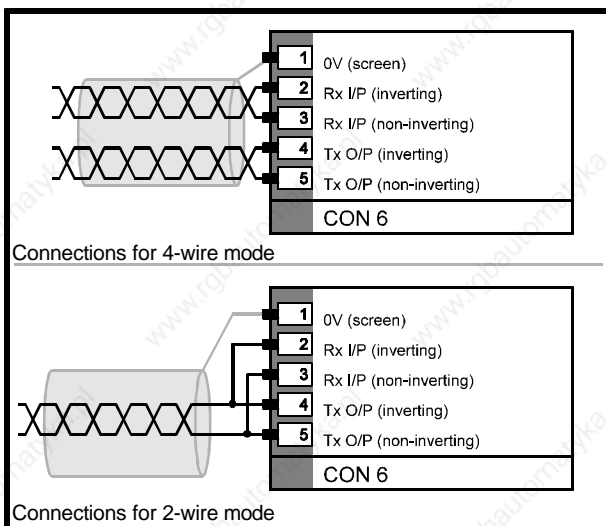

Figure 12–1 Serial communications connections (four-wire and two-wire modes)

12.3 Message structure

Messages consist of the following:

- Control characters
- Serial address code
- Parameter identifier
- Data field
- Block checksum (BCC)

The message structure is shown below.

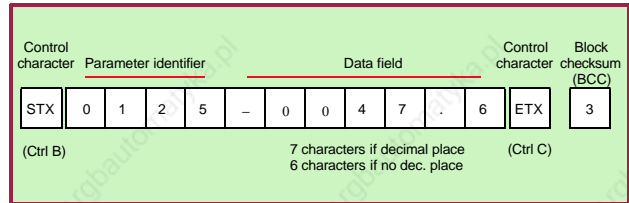

Figure 12–2 Structure of Serial Communications messages

Control characters

If a message is initiated from a keyboard, control characters may be entered by holding down the Ctrl key while pressing the key given in the last column of the table below:

Character	Purpose	ASCII code (HEX)	Key
EOT	Reset Message begins End of transmission	04	D
ENQ	Enquiry Interrogating the Drive	05	E
STX	Start of text	02	B
ETX	End of text	03	C
ACK	Acknowledge (Message accepted)	06	F
BS	Backspace (Go to previous parameter)	08	H
NAK	Negative acknowledge (Message not understood)	15	U

Serial address code

Each Drive on a serial communications link, must have an individual address code. The required serial address code should be entered in p11.23. The code must have two digits, and the number 0 must not be used. The first digit defines the group (1 to 9); the second digit defines the Drive number in the group (1 to 9).

The code for an individual Drive should be sent by the host as in this example:

Drive address code: 2 8

Address code to be sent by host: 2 2 8 8

To address all the Drives in Group 2, the host would need to send:

2 2 0 0

To address all Drives on the serial comms link, the host would need to send:

0 0 0 0

Parameter identifier

To address an individual parameter, the host needs to send a code that relates to the parameter number. For example:

To address: **p0.01**

Send: **0001**

Data field

Data are sent as numerical values with a negative polarity sign and decimal point when appropriate. The data field is of variable length, with a maximum of seven characters including the decimal point. The state of bit parameters is sent as numerical value **1** or **0**. For variable (**p**) parameters, having a series of options defined by character strings on the display (eg. **p7.10**), the first option (**std.H = 0**) is set by sending **0**, the second option (**Fast = 1**) by sending **1**, etc.

Block checksum

The block checksum character (BCC) is used to check that each message has not been corrupted when being sent. The BCC is a value that is calculated from the ASCII codes of the characters in the parameter and data fields.

The following example shows how the BCC is calculated.

A message for parameter **p1.25** contains the value – **47.6**. The parameter identifier is **0125** and the data field contains **–47.6**.

The Binary codes (for the parameter identifier) are as follows:

0	0011 0000
1	0011 0001
2	0011 0010
5	0011 0101

The first and second ASCII codes are compared in an **XOR** function. The result is **0000 0001**.

This result is compared with the third ASCII code (0011 0010) which produces the result **0011 0011**. This number is then compared with the next ASCII code. The process is repeated until the final digit in the data field is reached, as shown below:

Character	Binary code	XOR
0	011 0000	
1	011 0001	0000 0001
2	011 0010	0011 0011
5	011 0101	0000 0110
–	010 1101	0010 1011
4	011 0100	0001 1111
7	011 0111	0010 1000
.	010 1110	0000 0110
6	011 0110	0011 0000
ETX	000 0011	0011 0011
3	011 0011	

Note

If the decimal value is less than **32**, then **32** must be added. The resulting code is then used to derive the BCC.

Messages from host to Drive

Messages from the host to the Drive are used to:

- Interrogate the Drive for values or states of parameters
- Send a command to the Drive

12.4 Interrogate the Drive

To find the value of a parameter, the host should send a message that is structured as shown below.

The data field is not used. The final control character should be: **ENQ** (Ctrl E)

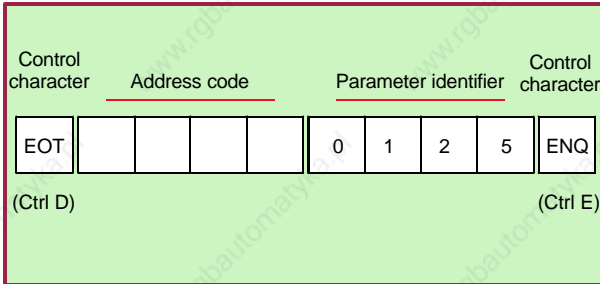

Figure 12-3 Message from host to interrogate the Drive

12.5 Send a command to the Drive

Commands are used to:

- Change the value of a parameter
- Control the operation of the Drive

To send a command, the message structure shown below should be used.

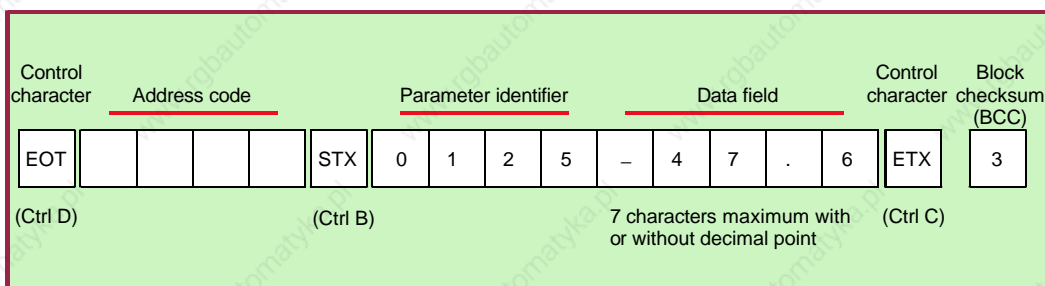

Figure 12-4 Sending a command to the Drive

12.6 Change a parameter value

To change a parameter, the message should contain the relevant parameter identifier. The data field should contain the required value.

For example, to set parameter **p1.25** at **-47.6Hz**, send:

Parameter identifier **0125**

Data field **-47.6**

To set **b1.10** at **1**, send:

Parameter identifier **0110**

Data field **1**

12.7 Control the Drive

To control the Drive using serial communications, no input terminals should be programmed to control the sequencing bits (**b6.08** to **b6.11**). They should be programmed using serial communications. It is suggested that **Sequencing mode 3** (PLC interface) is used for this.

To control operation of the Drive, the message should contain the relevant control parameter identifier. The data field should contain the value relating to the required control state. For example, to start the Drive, **b6.08** must be set at **1**.

Send:

Parameter identifier **0608**

Data field **1**

To stop the Drive, send:

Parameter identifier **0608**

Data field **0**

12.8 Messages from Drive to host

Messages from the Drive to the host are used to:

- Reply to an interrogation (send a message containing the value of the parameter specified by the host)

- Acknowledge a command from the host

12.9 Reply to an interrogation

When the Drive is interrogated for the value of a parameter, the Drive sends a message in reply that contains the parameter identifier and, in the data field, the value of the parameter.

The structure of reply messages is shown opposite.

12.10 Acknowledge a command

When a message has been sent by the host, the Drive responds by sending an acknowledgement.

If the message was a command, the Drive sends the reply message: **ACK**

If a command from the host is not understood, the Drive sends the reply message: **NAK**

A message can be misunderstood because:

- Transmission was corrupted
- Message was incorrectly structured
- Requested value was out of range

If the specified parameter number is not recognised by the Drive, the Drive sends the reply message: **EOT**

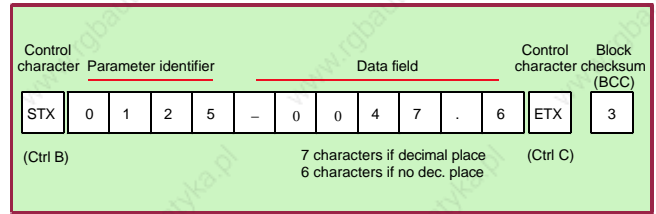

Figure 12-5 Drive replying to an interrogation

12.11 Other messages from host to Drive

Time can be saved by sending the control codes given below:

NAK (Ctrl U)	Repeat enquiry	Interrogate the Drive repeatedly for the current value of the last specified parameter.
ACK (Ctrl F)	Next parameter	Interrogate the Drive for the value of the next parameter in the list.
BS (Ctrl H)	Previous parameter	Interrogate the Drive for the value of the previous parameter in the list.

To ensure that the correct Drive answers, a valid full-length read or write must occur before these codes will work.

12.12 Summary of Serial Communications messages

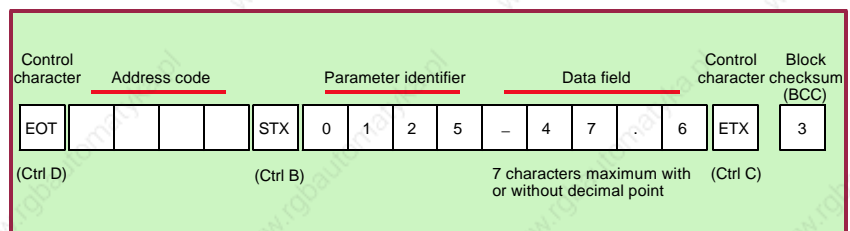

Figure 12-6 Sending a command to the Drive

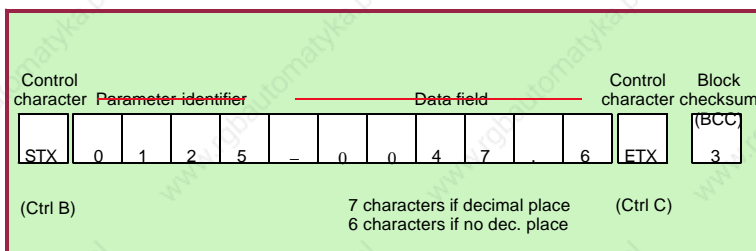

Figure 12-7 Drive replying to an interrogation

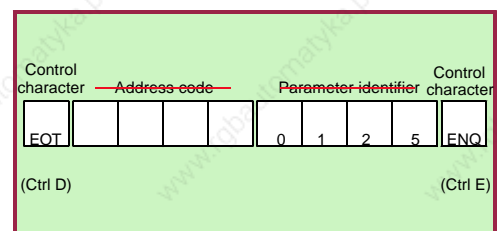

Figure 12-8 Message from host to interrogate the Drive

13 Control Techniques Worldwide Drive Centres and Distributors

Names and addresses are listed on the following pages.

