

E-Stop Safety Module – Model ES-FA-6G

E-Stop Safety Module Description

The purpose of an Emergency Stop Safety Module (E-Stop Safety Module) is to increase the control reliability of an emergency stop circuit. The ANSI B11.19 standard states:

“Control reliability of electrical, electronic, or pneumatic systems frequently consists of multiple, independent parallel or series circuitry or components so arranged that any single failure ... **either sends a stop command to the machine tool or prevents a successive cycle from being initiated.**”

In a functional Category 0 emergency stop circuit, opening of the E-stop switch contact(s) immediately removes power from the machine control elements, which react to arrest machine hazards. As indicated in Figures 3, 4, and 5, the model ES-FA-6G E-Stop Safety Module is designed for use with a 1-channel E-stop switch. A 1-channel E-stop switch has one contact.

The customer-supplied E-stop switch must be a “positive-opening device.” This means that its contact will open when the actuator is pushed with a certain minimum force, even if that contact was welded in the closed state.

As shown in Figure 2, the E-stop switch becomes an input to the E-Stop Safety Module. A short circuit between the two wires which connect the E-stop switch to the E-Stop Safety Module results in an unsafe condition. To reduce the possibility of a short circuit, the wires connecting the E-stop switch to the E-Stop Safety Module must be physically separated from each other and run in separate wireways or conduit.

The output of the E-Stop Safety Module consists of three redundant output switching channels, each of which is the series connection of two forced-guided relay contacts (K1 and K2 in Figure 2).

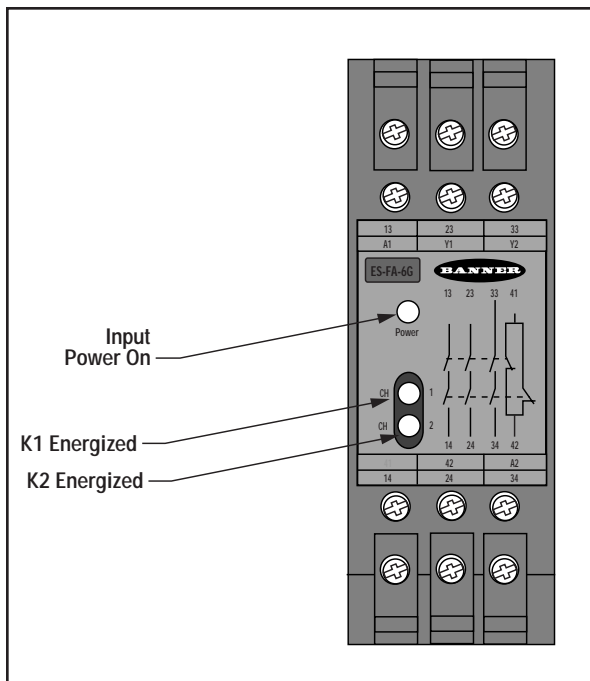

Figure 1. ES-FA-6G status indicators

As recommended by the control reliability section of ANSI B11.19, relays K1 and K2 in the output circuit of the E-Stop Safety Module have mechanically linked contacts which allow the Safety Module circuitry to monitor the contacts of K1 and K2 for failure. If the Safety Module detects failure of any contact of the output relays, the Safety Module output is disabled and cannot be reset.

The E-Stop Safety Module also provides a necessary reset function. ANSI B11 and NFPA 79 standards require that a reset routine be performed after returning the E-stop switch to its closed-contact position. This prevents the controlled machinery from restarting by simply closing the E-stop switch. Model ES-FA-6G may be configured for automatic reset by connecting terminals Y1 and Y2 together (see Figure 2). **The automatic reset mode is useful for some automated processes. However, when automatic reset is used, an alternate means must be established to require a reset routine after the E-stop switch is returned to its closed contact position (see WARNING on page 7).**

The three switching output circuits of the E-Stop Safety Module are rated for up to 250V ac at up to 6 amps. A normally closed non-safety auxiliary contact (between terminals #41 and 42) provides a monitoring signal for a process controller. This auxiliary contact is closed when the output circuits are open, and it is open when the output circuits are closed.

E-Stop Safety Module – Model ES-FA-6G

This E-stop Safety Module complies with the following design standards:

- UL991 Tests for Safety Related Control Employing Solid-state Devices
- EN418 Emergency Stop Equipment - Functional Aspects, Principals for Design
- EN954-1 Safety of Machines: Safety-related Parts of Controllers
Part 1: General Design Directives (Safety Category 2)

The Safety Module has indicators for input power and output relay contact status (K1 and K2); see Figure 1. There are no adjustments and no user-serviceable parts. See page 9 for information regarding repair service.

E-Stop Switch Requirements

As shown in Figure 3 or 4, the E-stop switch must provide one contact which is closed when the switch is in the “armed” position. Once activated, the E-stop switch must open this contact. The switch may be returned to the closed-contact position only by a deliberate action (such as twisting, pulling, or unlocking). Additionally, NFPA79 section 13.2, Emergency Stop Devices, specifies the following switch (“stop control”) requirements:

- Emergency Stop push buttons shall be located at each operator control station and at other operating stations where emergency shutdown shall be required.
- Stop and Emergency Stop push buttons shall be continuously operable from all control and operating stations where located.
- Actuators of Emergency Stop devices shall be colored RED. The background immediately around the device actuator shall be colored YELLOW. The actuator of a push-button-operated device shall be of the palm or mushroom-head type.
- The Emergency Stop actuator shall be a self-latching type.

NOTE: Some applications may have additional requirements. The user must refer to all relevant regulations.

Mechanical Installation

The E-stop Safety Module must be installed inside an enclosure. It is not designed for exposed wiring. It is the user’s responsibility to house the Safety Module in an enclosure with NEMA 3 (IEC IP54) rating, or better.

Dimensions of the Safety Module are shown in the diagram on page 11. The Safety Module mounts directly to standard 35 mm DIN rail.



CAUTION. . .
Shock Hazard
Always disconnect power
from the E-stop Safety

**Module and all power from the machine
being controlled before making any wire
connections.**

Electrical installation and wiring
must be made by qualified personnel
and must comply with the NEC
(National Electrical Code), EN60204-
1 and -2, and all applicable local
standards and codes.