

Type: MXPRF

Phase Failure, Phase Sequence and Under Voltage

- ☐ 17.5mm DIN rail housing
- ☐ True R.M.S.
- ☐ Microprocessor based (self checking)
- ☐ Monitors own supply and detects an Under voltage condition on one or more phases
- ☐ Measures phase to phase voltages
- ☐ Detects incorrect phase sequence and phase loss
- ☐ Fixed under voltage trip level
- ☐ Fixed time delay
- ☐ 1 x SPDT relay output 8A
- ☐ Intelligent LED indication for supply and relay status



Dims:
to DIN 43880
W. 17.5mm

Terminal Protection to IP20

FUNCTION DIAGRAM

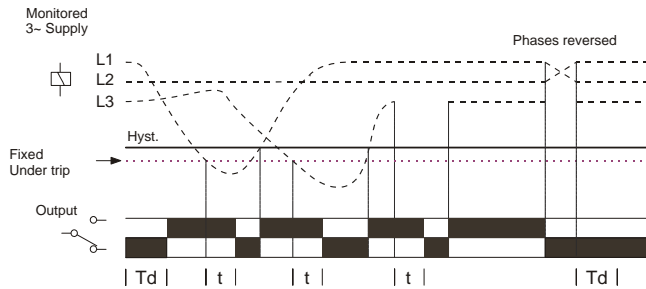

INSTALLATION AND SETTING



Installation work must be carried out by qualified personnel.

- BEFORE INSTALLATION, ISOLATE THE SUPPLY.
- Connect the unit as required. The Connection Diagram below shows a typical installation, whereby the supply to a load is being monitored by the Phase monitoring relay. If a fault should occur (i.e. fuse blowing), the relay will de-energise and assuming control of the external Contactor, de-energise the Contactor as well.

Applying power.

- Apply power and the green "Power supply" ① and red "Relay" ② LED's will illuminate, the relay will energise and contacts 15 and 18 will close. Refer to troubleshooting table if the unit fails to operate correctly.

Note:

If the supply voltage increases above the maximum supply/monitoring voltage range by approx. 10% or more, the relay will de-energise immediately.

This device is not suitable for applications where there could be a percentage of re-generative voltage present during a fault condition, i.e. fuse failure. During these conditions a monitor that includes an adjustable under voltage trip level is necessary which allows this type of fault to be detected. It is therefore recommended that the Mxprt or Mxprt-4w phase monitors be considered.

Troubleshooting.

The table below shows the status of the unit during a fault condition.

Supply fault	Green LED	Red LED	Relay
Phase missing	On	Off	De-energised
Phases reversed (no delay)	Flashing	Off	De-energised
Phase below 70% of Un (fixed under trip level [2])	On	Off	De-energised

CONNECTION DIAGRAM

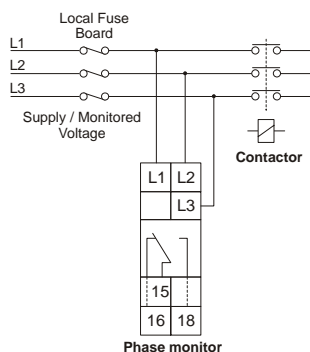

SETTINGS



1. Power supply status (Green) LED.
2. Relay output (Red) LED.

TECHNICAL SPECIFICATION

Supply / monitoring voltage U^* (L1, L2, L3): 77 - 143V AC
161 - 300V AC
280 - 520V AC¹
48 - 63Hz

Frequency range: Over voltage cat. III

Isolation: Over voltage cat. III

Rated impulse withstand voltage: 4kV¹ (1.2 / 50μs) IEC 60664

Power consumption: 8VA max.

*Please state Supply / monitoring voltage when ordering

Trip level: Under fixed $\pm 2\%$:

Voltage range: 77 - 143V AC
161 - 300V AC
280 - 520V AC

77V
161V
280V

Hysteresis: $\approx 2\%$ of trip level (factory set)

Repeat accuracy: $\pm 0.5\%$ @ constant conditions

Immunity from micro power cuts: < 50 mS

Response time: ≈ 50 mS

Time delay (t): ≈ 100 mS

Note: actual delay (t) = delay + response time

Delay from phase loss (tr): ≈ 150 mS (worst case = tr x 2)

Power on delay (Td): ≈ 1 sec. (worst case = Td x 2)

Ambient temp: -20 to +60°C

Relative humidity: +95%

Output (15, 16, 18): SPDT relay

Output rating: AC1 250V 8A (2000VA)
AC15 250V 5A (no), 3A (nc)
DC1 25V 8A (200W)

Electrical life: $\geq 150,000$ ops at rated load

Dielectric voltage: 2kV AC (rms) IEC 60947-1

Rated impulse withstand voltage: 4kV (1.2 / 50μs) IEC 60664

Housing: Orange flame retardant UL94 V0

Weight: ≈ 70 g

Mounting option: On to 35mm symmetric DIN rail to BS5584:1978 (EN50 002, DIN 46277-3) Or direct surface mounting via 2 x M3.5 or 4BA screws using the black clips provided on the rear of the unit.

Terminal conductor size: $\leq 2 \times 2.5\text{mm}^2$ solid or stranded

Approvals: Conforms to IEC, CE and and RoHS Compliant. EMC: Immunity: EN/IEC 61000-6-2 (EN/IEC 61000-4-3 15V/m 80MHz - 2.7GHz) Emissions: EN/IEC 61000-6-4

MOUNTING DETAILS

