

# Safety Precautions

To ensure safe operation, be sure to read and follow the Instruction Manual provided with the Sensor.

**⚠ CAUTION**

This product is not designed or rated for ensuring safety of persons either directly or indirectly. Do not use it for such purposes.

**Precautions for Correct Use**

Do not use the product in atmospheres or environments that exceed product ratings. This product is for surface mounting. Refer to Soldering Information, Storage and Baking for details.

Dispose of this product as industrial waste.

**Precautions for Safe Use**

**Do not use the product with a voltage or current that exceeds the rated range.**  
Applying a voltage or current that is higher than the rated range may result in explosion or fire.

**Do not miswire such as the polarity of the power supply voltage.**  
Otherwise the product may be damaged or it may burn.

**Do not short-circuit the load.**  
Otherwise explosion or burning may occur.

**This product does not resist water. Do not use the product in places where water or oil may be sprayed onto the product.**

# Dimensions and Internal Circuit

(Unit: mm)

## Photomicrosensor

EE-SX4320



Aperture size (H x W)

Emitter	Detector
1.4x1.4	1x0.3

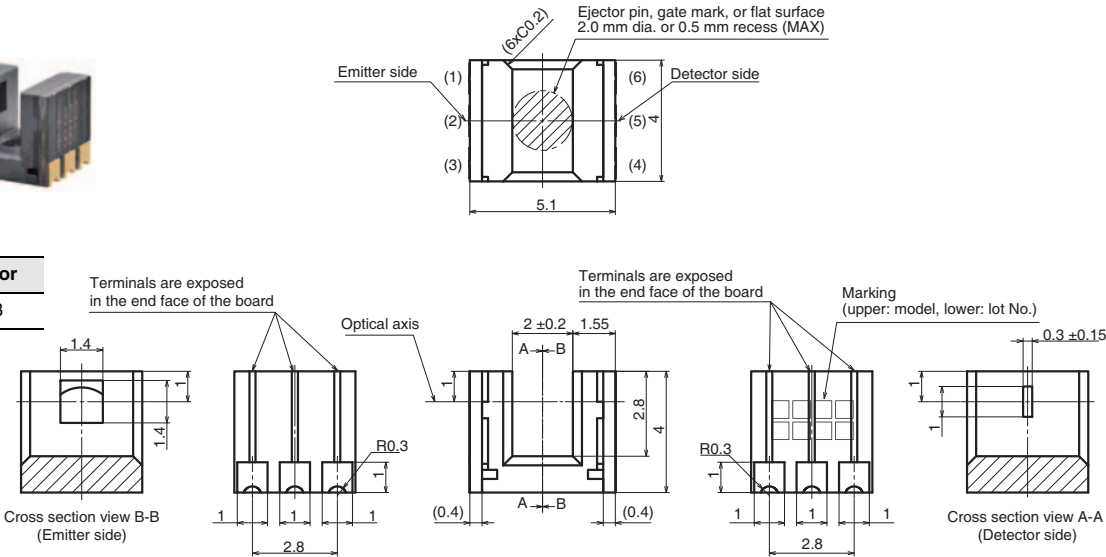

Internal circuit

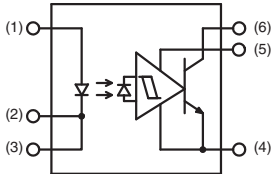

Terminal No.	Name
(1)	Anode
(2)(3)	Cathode
(4)	ground
(5)	Power supply voltage
(6)	Output

Unless otherwise specified, the tolerances are ±0.2 mm.

# Tape and Reel

## Reel (Unit: mm)

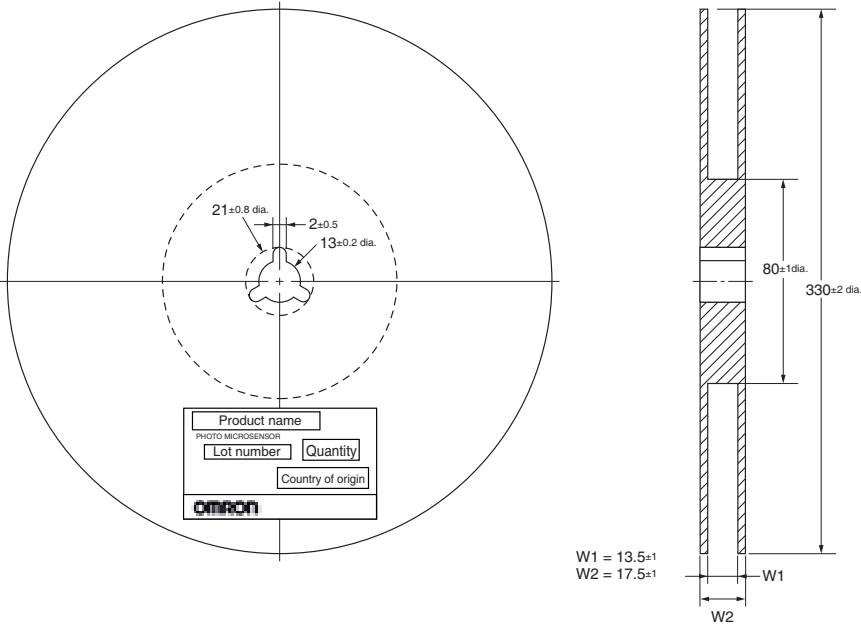

## Tape (Unit: mm)

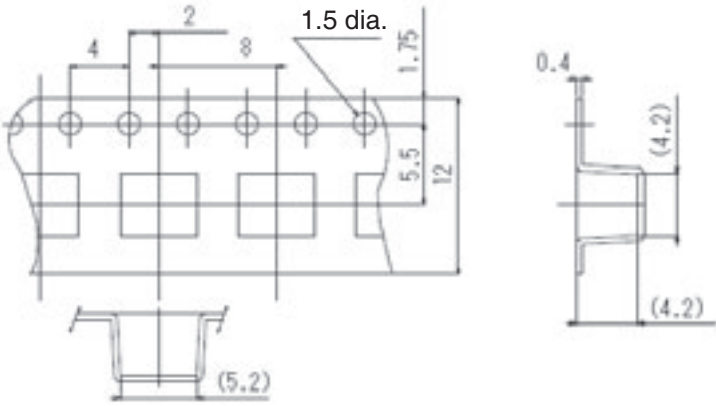

Note: Direction of product packing is upper figure.