

## A Low Power, High Sensitivity, Light-to-Digital Sensor With I<sup>2</sup>C Interface

The ISL29020 is a low power, high sensitivity, integrated light sensor with I<sup>2</sup>C (SMBus Compatible) interface. Its state-of-the-art photodiode array provides close-to human eye response and good IR rejection. This ADC is capable of rejecting 50Hz and 60Hz flicker caused by artificial light sources. The lux range select feature allows the user to program the lux range for optimized counts/lux.

In normal operation, typical power consumption 55µA. In order to further minimize power consumption, two power-down modes have been provided. If polling is chosen over continuous measurement of light, the auto-power-down function shuts down the whole chip after each ADC conversion for the measurement. The other power-down mode is controlled by software via the I<sup>2</sup>C interface. The power consumption can be reduced to less than 1µA when powered down.

Designed to operate on supplies from 2.25V to 3.3V with I<sup>2</sup>C supply from 1.7V to 3.6V, the ISL29020 is specified for operation over the -40°C to +85°C ambient temperature range.

### Ordering Information

PART NUMBER (Note)	PACKAGE (Pb-Free)	PKG. DWG. #
ISL29020IROZ-T7*	6 Ld ODFN	L6.2x2.1
ISL29020IROZ-EVALZ	Evaluation Board (Pb-free)	

\*Please refer to TB347 for details on reel specifications.

NOTE: These Intersil Pb-free plastic packaged products employ special Pb-free material sets; molding compounds/die attach materials and NiPdAu plate - e4 termination finish, which is RoHS compliant and compatible with both SnPb and Pb-free soldering operations. Intersil Pb-free products are MSL classified at Pb-free peak reflow temperatures that meet or exceed the Pb-free requirements of IPC/JEDEC J STD-020.

### Block Diagram

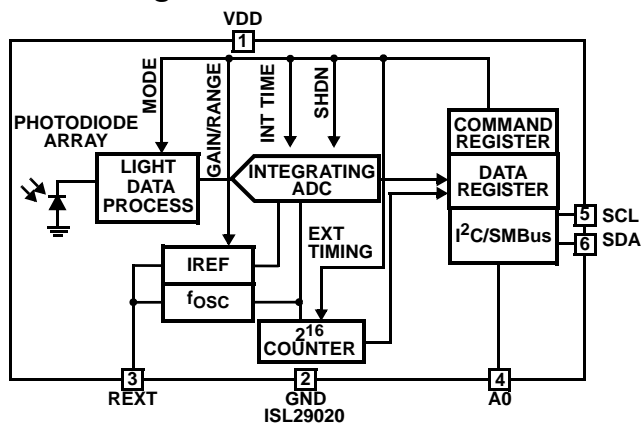

### Features

- Low Power
  - 65µA Max Operating Current
  - 0.5µA Max Shutdown Current
  - Software Shutdown and Automatic Shutdown
- Ideal Spectral Response
  - Close to Human Eye Response
  - Excellent IR and UV Rejection
- Easy to Use
  - Simple Output Code Directly Proportional to lux
  - I<sup>2</sup>C (SMBus Compatible) Output
  - No Complex Algorithms Needed
  - Variable Conversion Resolution up to 16-bits
  - Adjustable Sensitivity up to 65 Counts per lux
  - Works Under Various Light Sources, Including Sunlight
  - Selectable Range (via I<sup>2</sup>C)
    - Range 1 = 0.015 lux to 1,000 lux
    - Range 2 = 0.06 lux to 4,000 lux
    - Range 3 = 0.24 lux to 16,000 lux
    - Range 4 = 0.96 lux to 64,000 lux
  - Temperature Compensated
  - Integrated 50/60Hz Noise Rejection
- Small Form Factor
  - 2.0mmx2.1mmx0.7mm 6 Ld ODFN Package
- Additional Features
  - I<sup>2</sup>C and SMBus Compatible
  - 1.7V to 3.6V Supply for I<sup>2</sup>C Interface
  - 2.25V to 3.3V Supply
  - Address Selection Pin
- Pb-Free (RoHS compliant)

### Applications

- Display and keypad dimming for:
  - Mobile devices: smart phone, PDA, GPS
  - Computing devices: notebook PC, webpad
  - Consumer devices: LCD-TV, digital picture frame, digital camera
- Industrial and medical light sensing

### Pinout

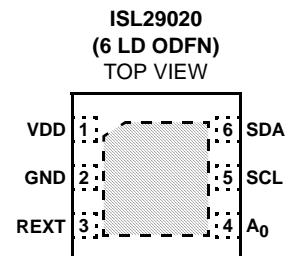

\*EXPOSED PAD CAN BE CONNECTED TO GND OR ELECTRICALLY ISOLATED

**Absolute Maximum Ratings** ( $T_A = +25^{\circ}\text{C}$ )

$V_{DD}$ Supply Voltage between $V_{DD}$ and GND	3.6V
$I^2C$ Bus Pin Voltage (SCL, SDA)	-0.2V to 3.6V
$I^2C$ Bus Pin Current (SCL, SDA)	<10mA
REXT, A0 Pin Voltage	-0.2V to $V_{DD}$
ESD Rating	
Human Body Model	.2kV

**Thermal Information**

Thermal Resistance	$\theta_{JA}$ ( $^{\circ}\text{C}/\text{W}$ )
6 Ld ODFN	88
Maximum Die Temperature	+90 $^{\circ}\text{C}$
Storage Temperature	-40 $^{\circ}\text{C}$ to +100 $^{\circ}\text{C}$
Operating Temperature	-40 $^{\circ}\text{C}$ to +85 $^{\circ}\text{C}$
Pb-Free Reflow Profile	see link below
	<a href="http://www.intersil.com/pbfree/Pb-FreeReflow.asp">http://www.intersil.com/pbfree/Pb-FreeReflow.asp</a>

CAUTION: Do not operate at or near the maximum ratings listed for extended periods of time. Exposure to such conditions may adversely impact product reliability and result in failures not covered by warranty.

IMPORTANT NOTE: All parameters having Min/Max specifications are guaranteed. Typical values are for information purposes only. Unless otherwise noted, all tests are at the specified temperature and are pulsed tests, therefore:  $T_J = T_C = T_A$

**Electrical Specifications**  $V_{DD} = 3\text{V}$ ,  $T_A = +25^{\circ}\text{C}$ ,  $R_{EXT} = 500\text{k}\Omega$  1% tolerance, 16-bit ADC operation, unless otherwise specified.

PARAMETER	DESCRIPTION	CONDITION	MIN	TYP	MAX	UNIT
$V_{DD}$	Power Supply Range		2.25		3.3	V
$I_{DD}$	Supply Current			55	65	$\mu\text{A}$
$I_{DD1}$	Supply Current when Powered Down	Software disabled or auto power-down		0.01	0.5	$\mu\text{A}$
$V_{I^2C}$	Supply Voltage Range for $I^2C$ Interface		1.7		3.6	V
$f_{OSC}$	Internal Oscillator Frequency		650	725	800	kHz
$t_{int}$	ADC Integration/Conversion Time	16-bit ADC data		90		ms
$F_{I^2C}$	$I^2C$ Clock Rate Range			1 to 400		kHz
DATA_0	Count Output When Dark	E = 0 lux, Range 1 (1k lux)		1	5	Counts
DATA_F	Full Scale ADC Code				65535	Counts
$\frac{\Delta\text{DATA}}{\text{DATA}}$	Count Output Variation Over Three Light Sources: Fluorescent, Incandescent and Sunlight	Ambient light sensing		$\pm 10$		%
DATA_1	Light Count Output With LSB of 0.015 lux/count	E = 300 lux, Fluorescent light (Note 1), Ambient light sensing, Range 1 (1k lux)	15000	20000	25000	Counts
DATA_2	Light Count Output With LSB of 0.06 lux/count	E = 300 lux, Fluorescent light (Note 1), Ambient light sensing, Range 2 (4k lux)		5000		Counts
DATA_3	Light Count Output With LSB of 0.24 lux/count	E = 300 lux, Fluorescent light (Note 1), Ambient light sensing, Range 3 (16k lux)		1250		Counts
DATA_4	Light Count Output With LSB of 0.96 lux/count	E = 300 lux, Fluorescent light (Note 1), Ambient light sensing, Range 4 (64k lux)		312		Counts
DATA_IR1	Infrared Count Output	E = 210 lux, Sunlight (Note 2), IR sensing, Range 1	15000	20000	25000	
DATA_IR2	Infrared Count Output	E = 210 lux, Sunlight (Note 2), IR sensing, Range 2		5000		
DATA_IR3	Infrared Count Output	E = 210 lux, Sunlight (Note 2), IR sensing, Range 3		1250		
DATA_IR4	Infrared Count Output	E = 210 lux, Sunlight (Note 2), IR sensing, Range 4		312		
$V_{REF}$	Voltage of REXT Pin			0.52		V
$V_{IL}$	SCL and SDA Input Low Voltage				0.55	V
$V_{IH}$	SCL and SDA Input High Voltage		1.25			V
$I_{SDA}$	SDA Current Sinking Capability		4	5		mA

NOTES:

- 550nm green LED is used in production test. The 550nm LED irradiance is calibrated to produce the same DATA count against an illuminance level of 300 lux fluorescent light.
- 850nm green LED is used in production test. The 850nm LED irradiance is calibrated to produce the same DATA\_IR count against an illuminance level of 210 lux sunlight at sea level.