

XU9N18NP341

photo-electric sensor - XU9 - polarised - Sn 2m -
12..24VDC - cable 2m

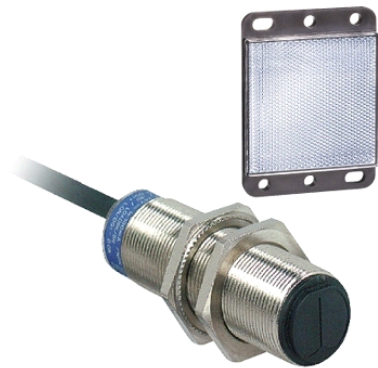

Main

Range of product	OsiSense XU
Series name	Application food and beverage
Electronic sensor type	Photo-electric sensor
Sensor name	XU9
Sensor design	Cylindrical M18
Detection system	Polarised reflex
Material	Stainless steel
Line of sight type	Axial
Type of output signal	Discrete
Supply circuit type	DC
Wiring technique	3-wire
Discrete output type	NPN
Discrete output function	1 NO or 1 NC programmable
Electrical connection	Cable
Cable length	2 m
Product specific application	-
Emission	Red polarised reflex
[Sn] nominal sensing distance	2 m polarised reflex need reflector XUZC50

Complementary

Enclosure material	Stainless steel : 304 CU
Lens material	PMMA
Maximum sensing distance	3 m
Output type	Solid state
Add on output	Without
Add on input	Programmation
Cable composition	4 x 0.34 mm ²
Wire insulation material	PvR
Cable outer diameter	4.2 mm
Status LED	1 LED (green) for supply on 1 LED (yellow) for output state
[Us] rated supply voltage	12...24 V DC with reverse polarity protection
Supply voltage limits	10...30 V DC
Switching capacity in mA	<= 100 mA (overload and short-circuit protection)
Switching frequency	<= 500 Hz
Voltage drop	<= 1.5 V (closed state)
Current consumption	<= 30 mA (no-load)
Delay first up	<= 15 ms
Delay response	<= 1 ms
Delay recovery	<= 1 ms
Setting-up	Without sensitivity adjustment
Diameter	18 mm
Length	72 mm
Product weight	0.085 kg
Kit composition	Sensor Reflector XUZC50

The information provided in this documentation contains general descriptions and/or technical characteristics of the products contained herein. This documentation is not intended as a substitute for and is not to be used for determining suitability or reliability of these products for specific user applications. It is the duty of any such user or integrator to perform the appropriate and complete risk analysis, evaluation and testing of the products with respect to the relevant specific application or use thereof. Neither Schneider Electric Industries SAS nor any of its affiliates or subsidiaries shall be responsible or liable for misuse of the information contained herein.

Environment

product certifications	CE CSA UL
ambient air temperature for operation	-25...55 °C
ambient air temperature for storage	-40...70 °C
vibration resistance	25 gn, amplitude = +/- 1.5 mm (f = 10...55 Hz) conforming to IEC 60068-2-6
shock resistance	30 gn (duration = 11 ms) conforming to IEC 60068-2-27
IP degree of protection	IP67 conforming to IEC 60529

Offer Sustainability

Sustainable offer status	Not Green Premium product
RoHS (date code: YYWW)	Will be Compliant on 3Q2013 Will be Compliant on 3Q2013
Product environmental profile	Available
Product end of life instructions	Available

Contractual warranty

Warranty period	18 months
-----------------	-----------

Dimensions

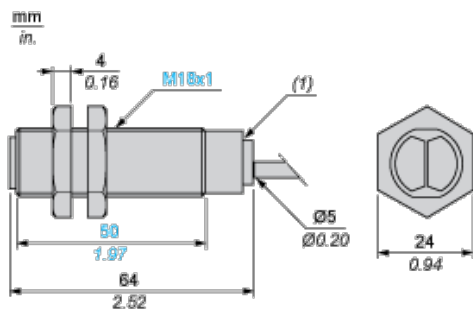

(1) LED

Mounting and Clearance

Fixing nut tightening torque: < 15 N.m

Connector tightening torque: 2 N.m

Wiring Schemes

3-wire, NPN NO or NC Programmable Function

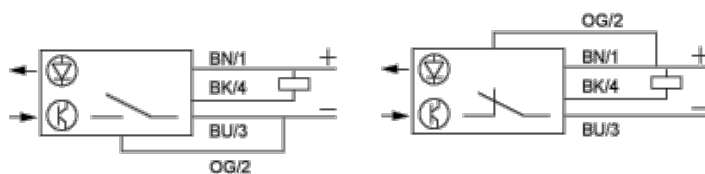

BN : Brown

BK : Black (out / output)

BU : Blue

OG : Orange (program)

Detection Curves

Polarised Reflex System with Reflector XUZC50

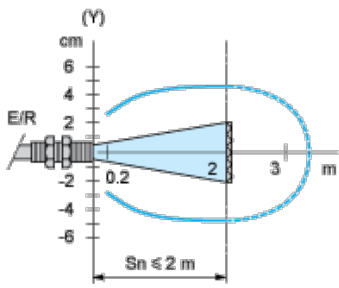

(y) \varnothing of beam

Excess Gain Curves (Ambient Temperature: + 25° C)

Polarised Reflex System with Reflector XUZC50

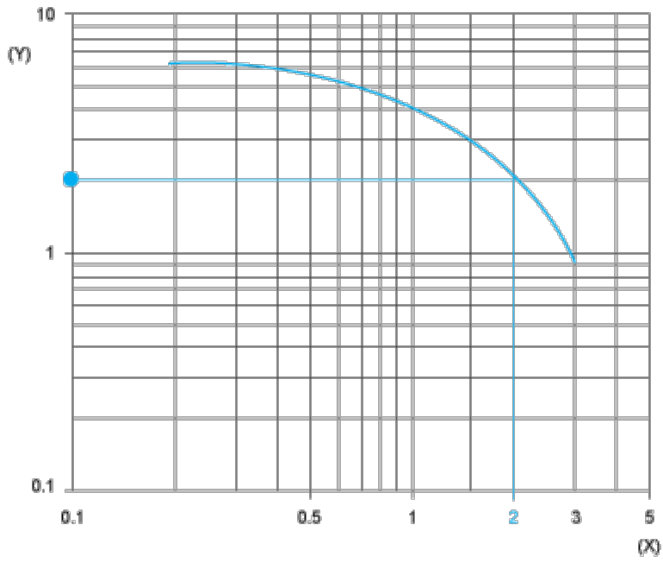

(y) Gain

(x) Distance (m)