

Power consumption	≤ 50 mA ³⁾
Switching frequency	6 kHz ⁴⁾
Response time	80 μs ⁵⁾
Jitter	40 μs
Output type	PNP
Switching output (voltage)	PNP: HIGH = V _S - ≤ 2 V / LOW approx. 0 V
Switching output	Light/dark switching
Output current I_{max}	< 100 mA ⁶⁾
Input, teach-in (ET)	PNP Teach: U = 10 V ... < U _V Run: U < 2 V
Connection type	Cable with M12 male connector, 4-pin, 0.2 m
Protection class	III
Circuit protection	U _V connections, reverse polarity protected Output Q short-circuit protected Interference pulse suppression
Enclosure rating	IP67
Weight	70 g
Housing material	ABS

¹⁾ Limit values: DC 12 V (-10 %) ... DC 24 V (+20 %). Operation in short-circuit protected network max. 8 A.

²⁾ May not exceed or fall below U_V tolerances.

³⁾ Without load.

⁴⁾ With light/dark ratio 1:1.

⁵⁾ Signal transit time with resistive load.

⁶⁾ At supply voltage > 24 V, I_{max} = 30 mA. I_{max} is consumption count of all Q_n.

Ambient data

Ambient operating temperature	-10 °C ... +55 °C
Ambient storage temperature	-20 °C ... +75 °C
Shock load	According to IEC 60068
UL File No.	NRKH.E348498 & NRKH7.E348498

Classifications

ECl@ss 5.0	27270908
ECl@ss 5.1.4	27270908
ECl@ss 6.0	27270908
ECl@ss 6.2	27270908
ECl@ss 7.0	27270908
ECl@ss 8.0	27270908
ECl@ss 8.1	27270908
ECl@ss 9.0	27270908
ETIM 5.0	EC001822
ETIM 6.0	EC001822
UNSPSC 16.0901	39121528

Dimensional drawing (Dimensions in mm (inch))

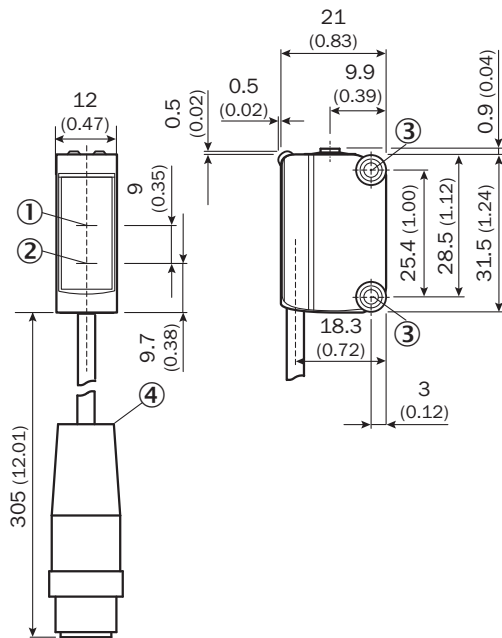

- ① Optical axis receiver
- ② Optical axis sender
- ③ M3 mounting hole
- ④ Cable with male connector

Adjustments

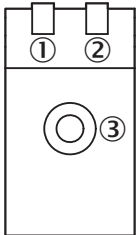

- ① Status indicator LED, yellow: Status switching output Q
- ② LED indicator green: Supply voltage active
- ③ Teach-in button

Connection diagram

Cd-023

