

# Model TS318-1B0814 Thermopile Sensor

## OPTICAL CHARACTERISTICS

Parameter	Symbol	Value	Unit	Description
Field of View	FOV	110	deg	at 50% of maximum signal

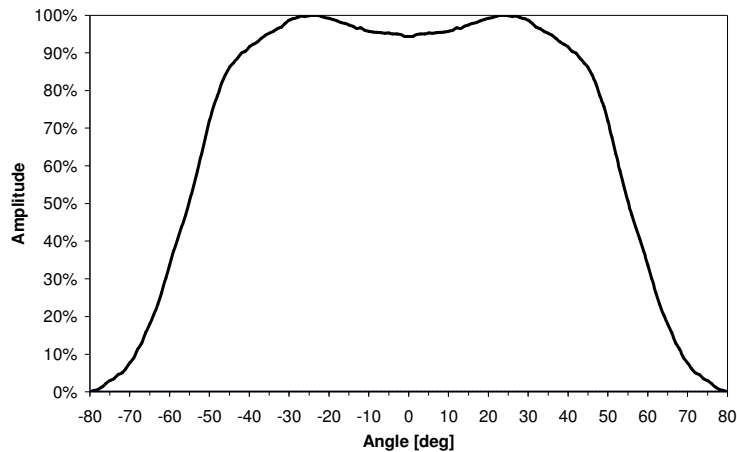

Figure 2: Field of View Curve

## FILTER CHARACTERISTICS

Parameter	Symbol	Value	Unit	Description
Transmission Range	BBP	8-14	$\mu\text{m}$	Broad Band Pass
Transmission	$T_{9 \dots 13\mu\text{m}}$	$\geq 75.0$	%	at 9 ... 13 $\mu\text{m}$

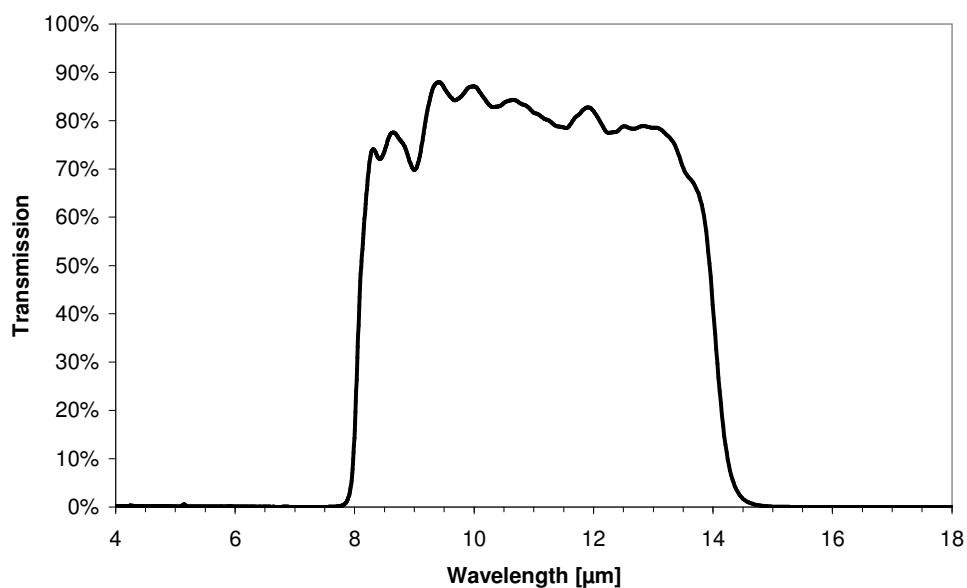

Figure 3: Filter transmission curve

# Model TS318-1B0814 Thermopile Sensor

## ELECTRICAL CONNECTIONS

Pin	Symbol
1	TP +
2	Ni-RTD
3	TP -
4	GND

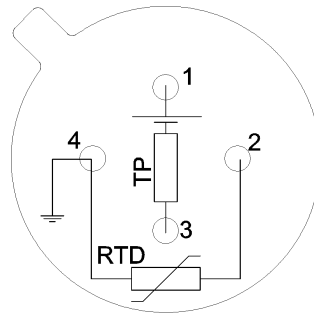
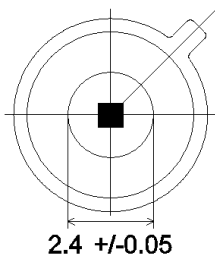

Figure 4: Electrical connections - bottom view of thermopile

## MECHANICAL DIMENSIONS

### TOP VIEW



### SIDE VIEW

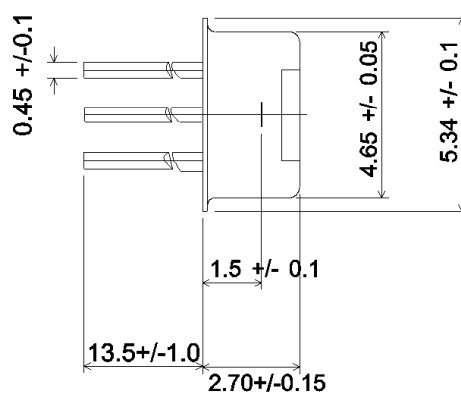

### BOTTOM VIEW

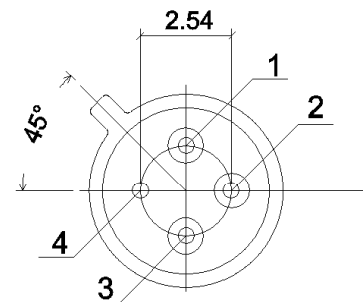

Figure 5: Mechanical dimensions of thermopile