

**HF3 S Relay** (Continued)

**Terminal assignment**

TOP view on component side of PCB  
Monostable

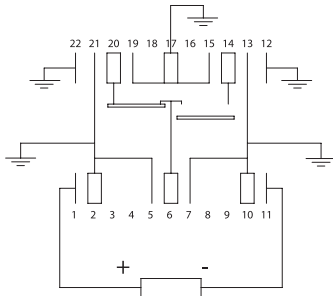

Bistable, 1 coil

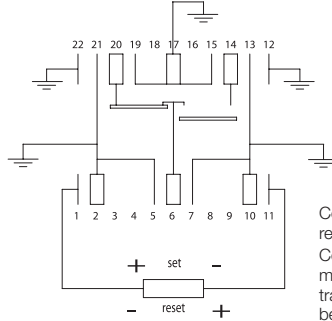

Bistable, 2 coils

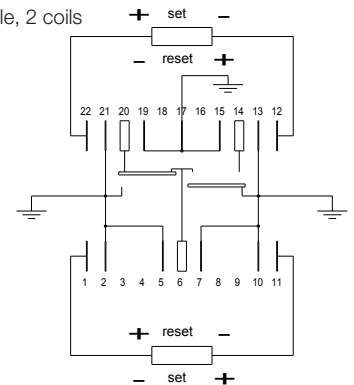

Contacts are shown in reset condition. Contact position might change during transportation and must be reset before use.

**PCB layout**

TOP view on component side of PCB

50Ω version

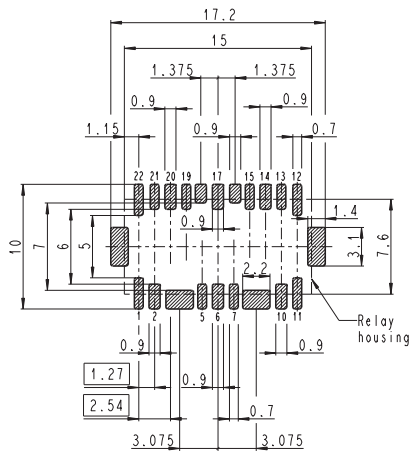

75Ω version

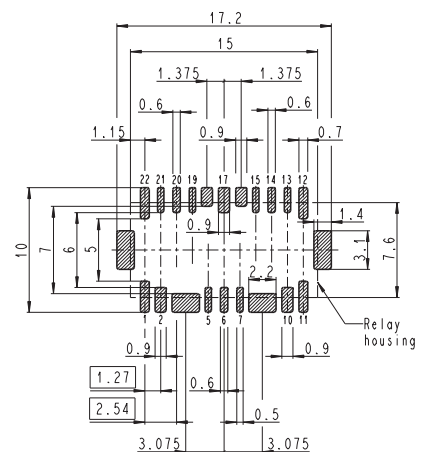

**Dimensions**

50Ω version

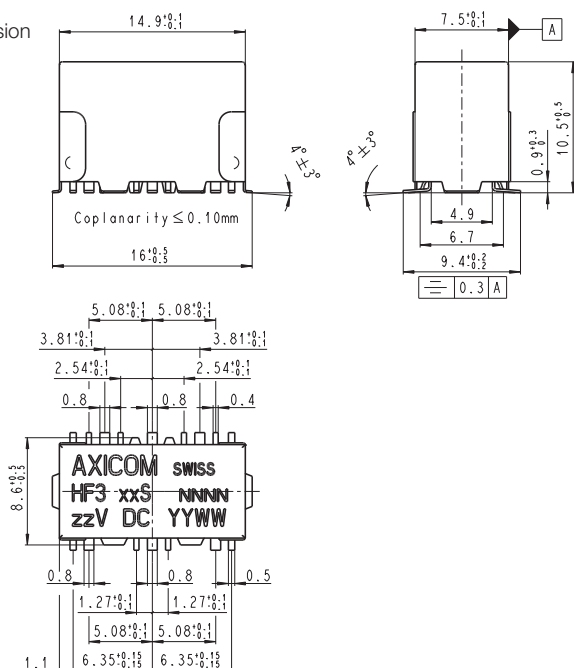

75Ω version

