

PET1300-12-054xA

AC-DC Front-End Power Supply

PET1300-12-054xA is a 1300 Watt AC to DC power-factor-corrected (PFC) power supply that converts standard AC mains power into a main output of 12 VDC for powering intermediate bus architectures (IBA) in high performance and reliability servers, routers, and network switches.

The PET1300-12-054xA meets international safety standards and displays the CE-Mark for the European Low Voltage Directive (LVD).

Key Features & Benefits

- High efficiency up to 94.0%
- Wide input voltage range: 90 – 264 VAC
- Active power factor correction
- Always-On 10 W standby output (3.3 V)
- Hot-plug capability
- Parallel operation with active current sharing
- Full digital control for circuit loop and power management
- High density design: 30.25 W/in³
- Compact form factor: 54.5 x 40.0 x 321.5 mm
- PMBus® Communication Interface for control, programming and monitoring
- Fully protected (OTP, OCP, OVP, SCP)
- 4K Bytes of EEPROM for user information
- 2 Status LEDs: FAIL and OK with fault signaling
- Approved to the latest edition of following Safety Standards: UL/CSA60950-1, IEC / EN 60950-1

Applications

- High Performance Servers
- Networking Switches
- Routers

Disclaimer: PMBus is a registered trademark of SMIF, Inc.



bel POWER
SOLUTIONS &
PROTECTION

a bel group

belfuse.com/power-solutions

1. ORDERING INFORMATION

PET	1300	-	12	-	054	x	A
Product Family	Power Level	Dash	V1 Output	Dash	Width	Airflow	Input
PET Front-Ends	1300 W		12 V		54 mm	N: Normal R: Reverse	A: AC

2. OVERVIEW

The PET1300-12-054xA AC/DC power supply is a fully DSP controlled, highly efficient front-end power supply. It incorporates resonance-soft-switching technology and interleaved power trains to reduce component stresses, providing increased system reliability and very high efficiency. With a wide input operational voltage range and minimal linear derating of output power with input voltage and temperature, the PET1300-12-054xA maximizes power availability in demanding server, network, and other high availability applications. The supply is fan cooled and ideally suited for integration with a matching airflow paths.

The PFC stage is an analogue solution; MCU is used to communicate with DSP chip on secondary side.

The DC/DC stage uses soft switching resonant techniques in conjunction with synchronous rectification. An active OR-ing device on the output ensures no reverse load current and hence it is ideally suited for operation in redundant power systems.

The always-on standby output with voltage level (3.3 Volts), provides power to external power distribution and management controllers. It is protected with an active OR-ing device for maximum reliability.

Status information is provided with front-panel LEDs. In addition, the power supply can be controlled and the fan speed set via the I²C bus. The I²C bus allows full monitoring of the supply, including input and output voltage, current, power, and inside temperatures.

Cooling is managed by a fan controlled by the DSP controller. The fan speed is adjusted automatically depending on the actual power demand and supply temperature and can be overridden through the I²C bus.

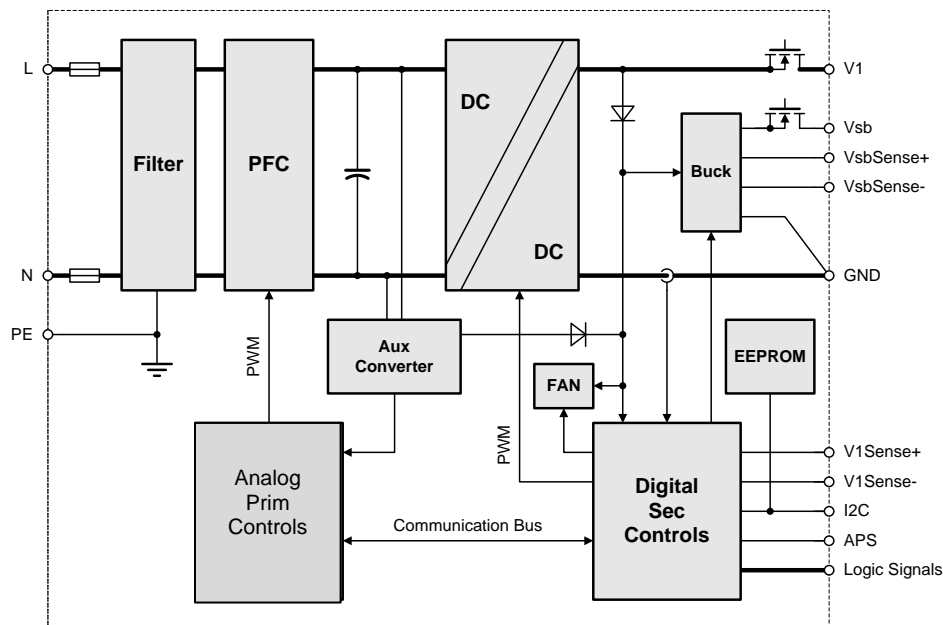

Figure 1. PET1300-12-054xA Block Diagram