

PFE1300-48-054NA

1300 W, 48 VDC Output

The PFE1300-48-054NA is a 1300 Watt AC to DC power-factor-corrected (PFC) power supply that converts standard AC mains power into a main output of 48 VDC for powering intermediate bus architectures (IBA) in high performance and reliability servers, routers, and network switches. The PFE1300-48-054NA meets international safety standards and displays the CE-Mark for the European Low Voltage Directive (LVD).



Key Features & Benefits

- Best-in-class, “Platinum” efficiency
- Wide input voltage range: 90-264 VAC
- High Power Density design: 30.25 W/in³
- Small form factor: 54.5 x 40.0 x 321.5 mm
- AC input with power factor correction
- Always-On 16.5 W programmable standby output (3.3/5 V)
- Hot-plug capable
- Parallel operation with active digital current sharing
- I²C communication interface for control, programming and monitoring with PMBus® protocol
- Over temperature, output over voltage and over current protection
- 256 Bytes of EEPROM for user information
- 2 Status LEDs: AC OK and DC OK with fault signaling

Applications

- High performance servers
- Routers
- Switches

Disclaimer: PMBus is a registered trademark of SMIF, Inc.

1 ORDERING INFORMATION

PFE	1300	-	48	-	054	N	A
Product Family PFE Front-Ends	Power Level 1300 W	Dash	V1 Output 48 V	Dash	Width 54 mm	Airflow N: Normal	Input A: AC

*PFE1300-48-054NAS407 has black front panel with white text

2 OVERVIEW

The PFE1300-48-054NA AC/DC power supply is combination of analog and DSP control, highly efficient front-end power supply.

It incorporates resonance-soft-switching technology to reduce component stresses, providing increased system reliability and very high efficiency. With a wide input operational voltage range and minimal linear derating of output power with input voltage and temperature, the PFE1300-48-054NA maximizes power availability in demanding server, network, and other high availability applications. The supply is fan cooled and ideally suited for integration with a matching airflow paths.

The PFC stage guarantee best efficiency and unity power factor over a wide operating range. The DC/DC stage uses soft switching resonant techniques in conjunction with synchronous rectification. An active OR-ing device on the output ensures no reverse load current and renders the supply ideally suited for operation in redundant power systems.

The always-on standby output, with selectable voltage level (3.3/5.0 Volts), provides power to external power distribution and management controllers. It is protected with an active OR-ing device for maximum reliability.

Status information is provided with front-panel LEDs. In addition, the power supply can be controlled and the fan speed set via the I²C bus. The I²C bus allows full monitoring of the supply, including input and output voltage, current, power, and inside temperatures.

Cooling is managed by a fan controlled by the DSP controller. The fan speed is adjusted automatically depending on the actual power demand and supply temperature and can be overridden through the I²C bus.

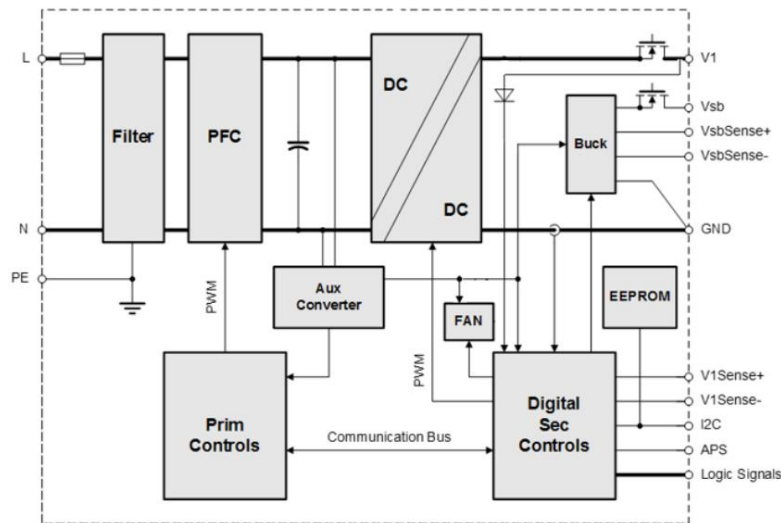

Figure 1. PFE1300-48-054NA Block Diagram

3 ABSOLUTE MAXIMUM RATINGS

Stresses in excess of the absolute maximum ratings may cause performance degradation, adversely affect long-term reliability, and cause permanent damage to the supply.

PARAMETER	DESCRIPTION / CONDITION	MIN	NOM	MAX	UNIT
V_i max	Maximum Input			264	VAC