

## 2. OVERVIEW

The PFE1500 Series AC/DC power supply is combination of analog and DSP control, highly efficient front-end power supply. It incorporates resonance-soft-switching technology and interleaved power trains to reduce component stresses, providing increased system reliability and very high efficiency. With a wide input operational voltage range and minimal derating of output power with input voltage and temperature, the PFE1500 power supply maximizes power availability in demanding server, network, and other high availability applications. The supply is fan cooled and ideally suited for integration with a matching airflow paths. The PFC stage is an analogue solution; MCU is used to communicate with DSP chip on secondary side. The DC/DC stage uses soft switching resonant techniques in conjunction with synchronous rectification. An active OR-ing device on the output ensures no reverse load current and renders the supply ideally suited for operation in redundant power systems. The always-on standby output, provides power to external power distribution and management controllers. It is protected with an active OR-ing device for maximum reliability. Status information is provided with front-panel LEDs.

In addition, the power supply can be controlled and the fan speed set via the I2C bus. The I2C bus allows full monitoring of the supply, including input and output voltage, current, power, and inside temperatures. The fan speed is adjusted automatically depending on the actual power demand and supply temperature and can be overridden through the I2C bus.

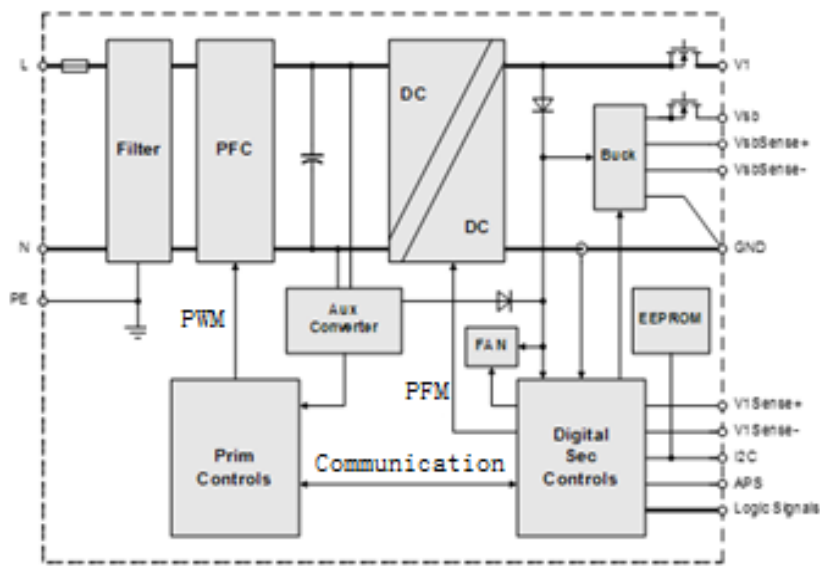

Figure 1. PFE1500 Series Block Diagram

## 3. ABSOLUTE MAXIMUM RATINGS

Stresses in excess of the absolute maximum ratings may cause performance degradation, adversely affect long-term reliability, and cause permanent damage to the supply.

PARAMETER	DESCRIPTION / CONDITION	MIN	NOM	MAX	UNIT
$V_{i\ maxc}$ Maximum Input	Continuous			264	VAC



Asia-Pacific  
+86 755 298 85888

Europe, Middle East  
+353 61 225 977

North America  
+1 408 785 5200

## 4. INPUT SPECIFICATIONS

General Condition:  $T_A = 0 \dots 45^\circ\text{C}$  unless otherwise specified.

PARAMETER	DESCRIPTION / CONDITION	MIN	NOM	MAX	UNIT
$V_{i,nom}$	Nominal Input Voltage	100		240	VAC
		200		350 <sup>1</sup>	VDC
$V_i$	Input Voltage Ranges	Normal operating ( $V_{i,min}$ to $V_{i,max}$ )		264	VAC
		180		350	VDC
$V_{i,red}$	Derating Input Voltage Range	90		180	VAC
$I_{i,max}$	Max Input Current			15	A <sub>rms</sub>
$I_{i,p}$	Inrush Current Limitation	$V_{i,min}$ to $V_{i,max}$ , $T_{NTC} = 25^\circ\text{C}$ (Figure 4)		40	A <sub>p</sub>
$F_i$	Input Frequency	47	50/60	64	Hz
$PF$	Power Factor	$V_{i,nom}$ , 50 Hz, $> 0.3 I_{i,nom}$			W/VA
$V_{i,on}$	Turn-on Input Voltage <sup>2</sup>	Ramping up		89	VAC
		80	174	180	VDC
$V_{i,off}$	Turn-off Input Voltage	Ramping down		85	VAC
		75	171	176	VDC
$\eta$	Efficiency without Fan at AC input	$V_{i,nom}$ , $0.1 \cdot I_{i,nom}$ , $V_{x,nom}$ , $T_A = 25^\circ\text{C}$		90	
		$V_{i,nom}$ , $0.2 \cdot I_{i,nom}$ , $V_{x,nom}$ , $T_A = 25^\circ\text{C}$		92	
		$V_{i,nom}$ , $0.5 \cdot I_{i,nom}$ , $V_{x,nom}$ , $T_A = 25^\circ\text{C}$		94	
	Efficiency without Fan at DC input	$V_{i,nom}$ , $I_{i,nom}$ , $V_{x,nom}$ , $T_A = 25^\circ\text{C}$		92	%
		$V_{i,nom}=336\text{VDC}$ , $0.1 \cdot I_{i,nom}$ , $V_{x,nom}$ , $T_A = 25^\circ\text{C}$		89	
		$V_{i,nom}=336\text{VDC}$ , $0.2 \cdot I_{i,nom}$ , $V_{x,nom}$ , $T_A = 25^\circ\text{C}$		92	
$T_{hold}$	Hold-up Time	After last AC zero point to $V_i \geq 10.8\text{ V}$ , $V_{SB}$ within regulation, $V_i = 230\text{ VAC}$ , $P_{x,nom}$		10	ms
				93.5	
		$V_{i,nom}=336\text{VDC}$ , $I_{i,nom}$ , $V_{x,nom}$ , $T_A = 25^\circ\text{C}$		92	

### 4.1 INPUT FUSE

Quick-acting 16 A input fuse (5 x 20 mm) in series the L line inside the power supply protect against severe defects. The fuses are not accessible from the outside and are therefore not serviceable parts.

### 4.2 INRUSH CURRENT

The AC-DC power supply exhibits an X-capacitance of only 3.2  $\mu\text{F}$ , resulting in a low and short peak current, when the supply is connected to the mains. The internal bulk capacitor will be charged through an NTC which will limit the inrush current.

**NOTE:** Do not repeat plug-in / out operations within a short time, or else the internal in-rush current limiting device (NTC) may not sufficiently cool down and excessive inrush current or component failure(s) may result.

<sup>1</sup> For PFE1500-12-054NAH, PFE1500-12-054RAH and PFE1500-12NAHS412, normal DC operation input range is 200 VDC to 380 VDC and Input range is 180 VDC to 400 VDC; input AC range is 90 VAC ~ 264 VAC.

<sup>2</sup> The Front-End is provided with a minimum hysteresis of 3 V during turn-on and turn-off within the ranges.