

TET3000-12-069RA

AC-DC Front-End Power Supply

The TET3000-12-069RA is a 3000 Watt AC-DC power-factor-corrected (PFC) DC/DC power supply that converts standard AC mains power or high voltage DC bus voltages into a main output of 12 VDC for powering intermediate bus architectures (IBA) in high performance and reliability servers, routers, and network switches.

The TET3000-12-069RA meets international safety standards and displays the CE-Mark for the European Low Voltage Directive (LVD).



Key Features & Benefits

- Best-in-class, Titanium efficiency
- Universal input voltage range: 90 - 300 VAC
- AC input with power factor correction
- DC input voltage range: 180 - 410 VDC
- Hot-plug capable
- Parallel operation with active current sharing thru analog bus
- Full digital controls for improved performance
- High density design: 31.7 W/in³
- Small form factor: 69 x 40.5 x 555 mm
- I2C communication interface with PMBus® protocol for monitoring, control, and firmware update via bootloader
- Overtemperature, output overvoltage and overcurrent protection
- RoHS Compliant
- 2 Status LEDs: AC OK and DC OK with fault signaling
- Safety-approved to IEC/EN 60950-1 and UL/CSA 60950-1 2nd Ed.
- Three US patents (US 6,970,366 B2; US 8,503,199 B1; US9,166,498 B2) and three US patents pending

Applications

- High Performance Servers
- Routers
- Networking Switches

Disclaimer: PMBus is a registered trademark of SMIF, Inc.

1. ORDERING INFORMATION

TET	3000	-	12	-	069	R	A	Option Code
Product Family	Power Level	Dash	V1 Output	Dash	Width	Airflow	Input	
TET Front-End	3000 W		12 V		69 mm	R: Reverse ¹⁾	A: AC	Blank: Standard model

¹⁾ Front to Rear

2. OVERVIEW

The TET3000-12-069RA is a fully DSP controlled, highly efficient front-end power supply. It incorporates resonant-soft-switching technology and interleaved power trains to reduce component stresses, providing increased system reliability and very high efficiency. With a wide input operating voltage range and minimal linear derating of output power with respect to ambient temperature, the TET3000-12-069RA maximizes power availability in demanding server, switch, and router applications. The power supply is fan cooled and ideally suited for server integration with a matching airflow path.

The PFC stage is digitally controlled using a state-of-the-art digital signal processing algorithm to guarantee best efficiency and unity power factor over a wide operating range.

The DC-DC stage uses soft switching resonant techniques in conjunction with synchronous rectification. An active OR-ing device on the output ensures no reverse load current and renders the supply ideally suited for operation in redundant power systems. The always-on +12V standby output provides power to external power distribution and management controllers. Its protection with an active OR-ing device provides for maximum reliability.

Status information is provided with front-panel LEDs. In addition, the power supply can be monitored and controlled (i.e. fan speed setpoint) via I2C communication interface with PMBus® protocol. It allows full monitoring of the supply, including input and output voltage, current, power, and inside temperatures. The same I2C bus supports the bootloader to allow field update of the firmware in the DSP controllers.

Cooling is managed by a fan, controlled by the DSP controller. The fan speed is adjusted automatically depending on the actual power demand and supply temperature and can be overridden through the I2C buses.

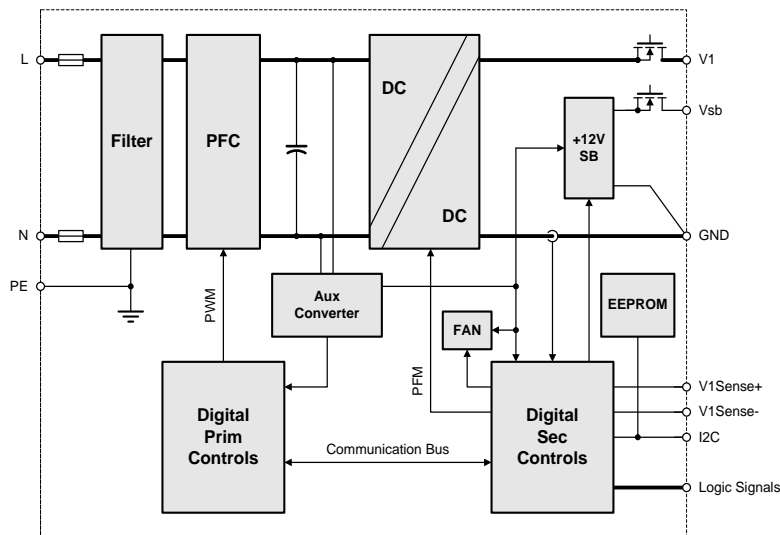

Figure 1. TET3000-12-069RA Block Diagram

3. ABSOLUTE MAXIMUM RATINGS

Stresses in excess of the absolute maximum ratings may cause performance degradation, adversely affect long-term reliability and cause permanent damage to the supply.

PARAMETER	CONDITIONS / DESCRIPTION		MIN	MAX	UNITS
V_i maxc	Maximum Input	Continuous		300	VAC