

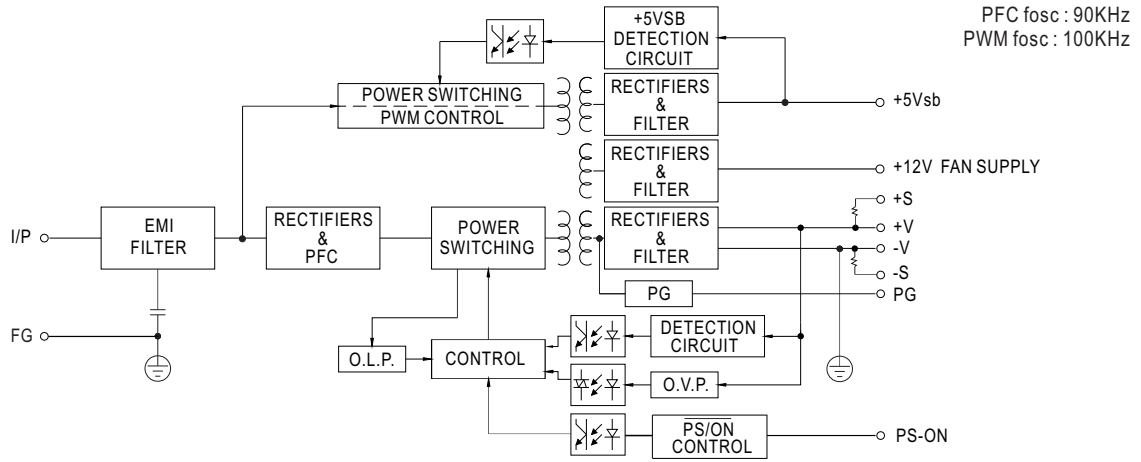

SPECIFICATION

SAFETY & EMC (Note 6)	SAFETY STANDARDS	UL62368-1, TUV EN62368-1, IEC62368-1, EAC TP TC 004 approved										
	WITHSTAND VOLTAGE	I/P-O/P:3KVAC I/P-FG:2KVAC O/P-FG:0.5KVAC										
	ISOLATION RESISTANCE	I/P-O/P, I/P-FG:100M Ohms / 500VDC / 25°C / 70% RH										
	EMC EMISSION	Parameter	Standard	Test Level / Note								
		Conducted	EN55032(CISPR32), CNS13438	Class I : Class B , Class II : Class A								
		Radiated	EN55032(CISPR32), CNS13438	Class A								
		Harmonic Current	EN61000-3-2	Class A								
		Voltage Flicker	EN61000-3-3	-----								
	EMC IMMUNITY	EN55024, EN61000-6-2										
		Parameter	Standard	Test Level /Note								
ESD		EN61000-4-2	Level 3, 8KV air; Level 2, 4KV contact, criteria A									
Radiated Susceptibility		EN61000-4-3	Level 3, criteria A									
EFT/Burest		EN61000-4-4	Level 3, criteria A									
Surge		EN61000-4-5	Level 4,2KV/L-N, criteria A									
Conducted		EN61000-4-6	Level 3, criteria A									
Magnetic Field		EN61000-4-8	Level 4, criteria A									
	Voltage Dips and interruptions	EN61000-4-11	>95% dip 0. 5 periods, 30% dip 25 periods, >95% interruptions 250 periods									
OTHERS	MTBF	194.1Khrs min. MIL-HDBK-217F (25°C)										
	DIMENSION	L*W*H	127x76.2x40mm									
			5"x3"x1.57"inch									
	PACKING	P.W.	0.46Kg									
		Q'TY	30pcs									
		G.W.	14.8Kg									
M'MENT		1.03CUFT										
NOTE	<p>1. All parameters NOT specially mentioned are measured at 230VAC input, rated load and 25 of ambient temperature. 2. Ripple & noise are measured at 20MHz of bandwidth by using a 12" twisted pair-wire terminated with a 0.1μf & 47μf parallel capacitor. 3. Tolerance : includes set up tolerance, line regulation and load regulation. 4. Derating may be needed under low input voltages. Please check the derating curve for more details. 5. The ambient temperature derating of 3.5°C/1000m with fanless models and of 5°C/1000m with fan models for operating altitude higher than 2000m(6500ft). 6. The power supply is considered a component which will be installed into a final equipment. All the Class I (with FG) EMC test are been executed by mounting the unit on a 360mm*360mm metal plate with 1mm of thickness. final equipment must be re-confirmed that it still meets EMC directives. For guidance on how to perform these EMC tests, please refer to "EMI testing of component power supplies." (as available on http://www.meanwell.com)</p> <table border="1" style="margin-left: auto; margin-right: auto;"> <tr> <td>EMI Performance</td> <td>Conducted</td> <td>Radiated</td> </tr> <tr> <td>Class I (with FG)</td> <td>Class B</td> <td>Class A</td> </tr> <tr> <td>Class II (no FG)</td> <td>Class A</td> <td>Class A</td> </tr> </table>			EMI Performance	Conducted	Radiated	Class I (with FG)	Class B	Class A	Class II (no FG)	Class A	Class A
EMI Performance	Conducted	Radiated										
Class I (with FG)	Class B	Class A										
Class II (no FG)	Class A	Class A										

■ Block Diagram



■ Derating Curve

■ Output Derating VS Input Voltage

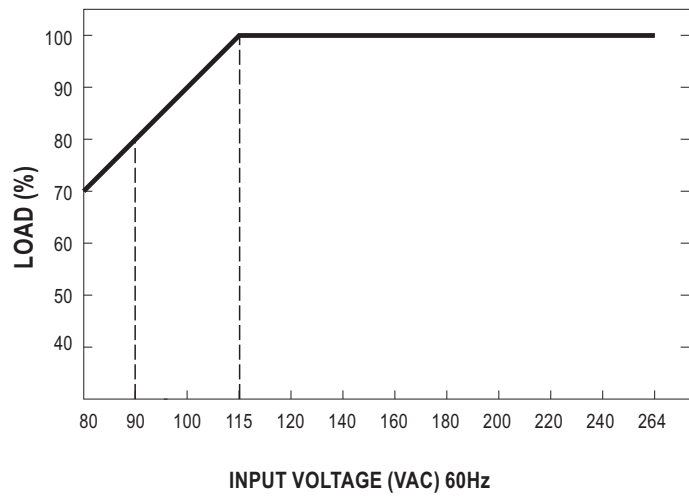
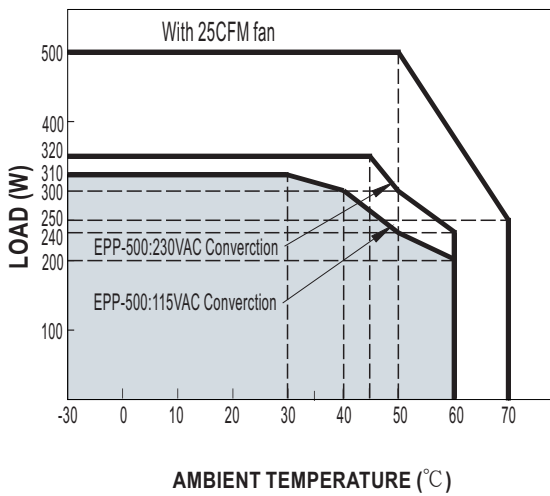

Convection	320W/230Vac 310W/115Vac
Force Air	500W