

Block Diagram

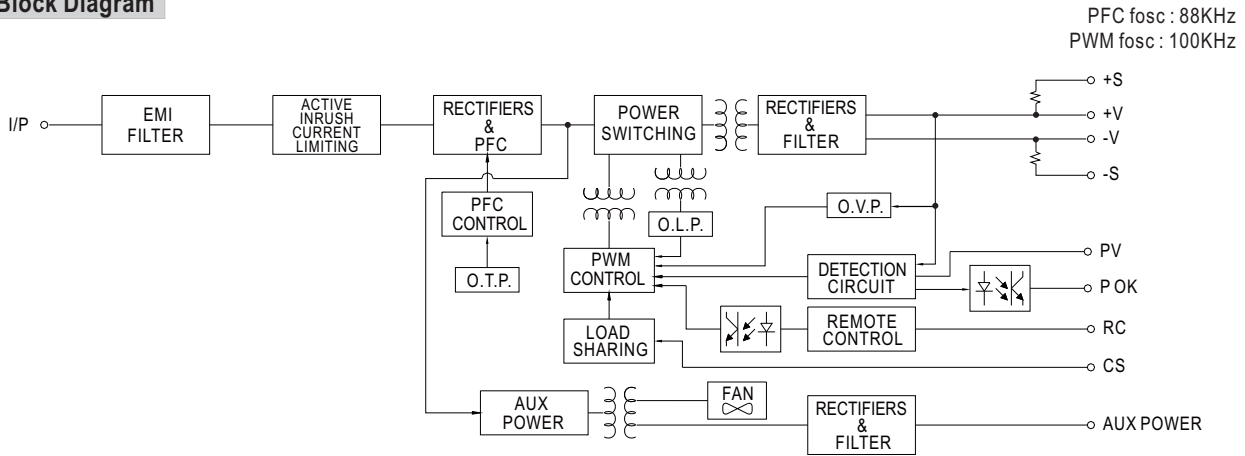

Static Characteristics

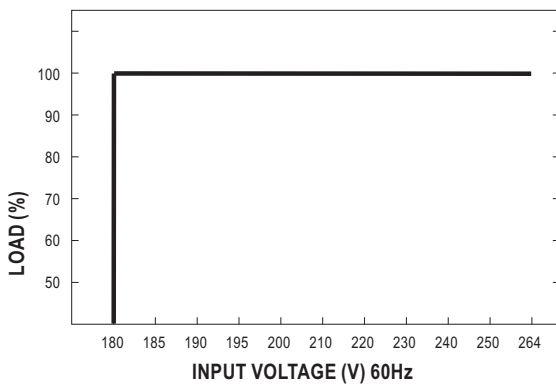

MODEL	12V	24V	48V
INPUT	180~264VAC	180~264VAC	180~264VAC
Power	2000.4W	2400W	2400W
Current	166.7A	100A	50A

Derating Curve

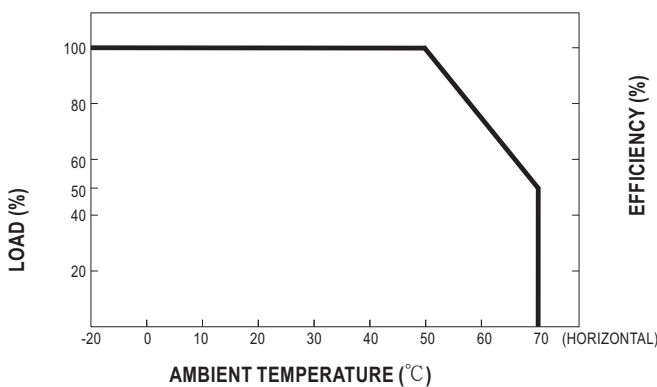

Efficiency vs Load (48V Model)

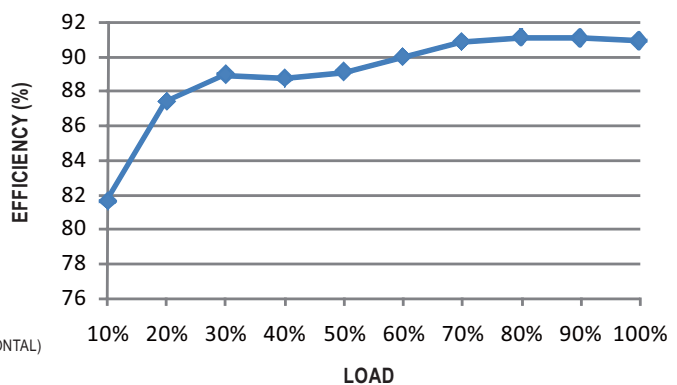

※ The curve above is measured at 230VAC.

■ Function Manual

1. Remote Sense

※ The Remote Sense compensates voltage drop on the load wiring up to 0.25V

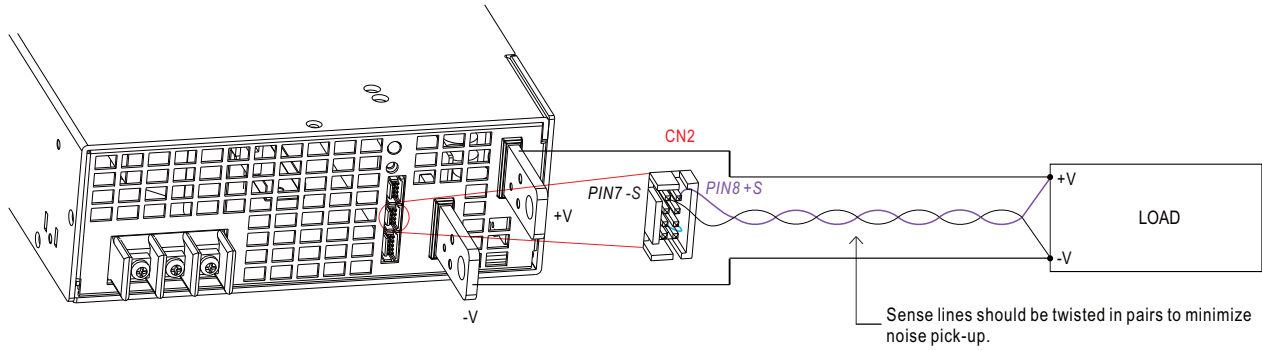

※ Caution: The power supply, by factory default (also the assumption for other sections), is shipped with, -S & -V on CN2, as well as +S & +V, shorted by connector. When activating the Remote Sense, the +S signal should be connected to the positive terminal of the load whereas -S signal to the negative terminal.

2. Output Voltage Programming (or, PV / remote voltage programming / remote adjust / margin programming / dynamic voltage trim)

※ In addition to the adjustment via the built-in potentiometer, the output voltage can be trimmed to 20~110% (Typ.) of the nominal voltage by applying EXTERNAL VOLTAGE.

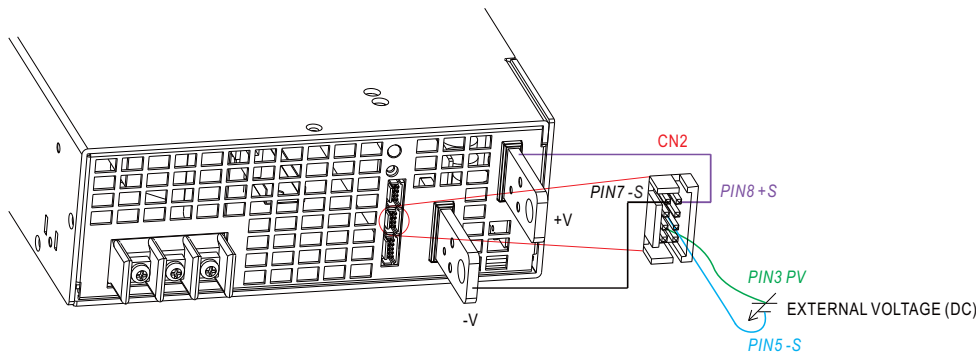

◎ Connecting an external DC source between PV & -S on CN2, and +S & +V, -S & -V also need to be connected as exhibited above.

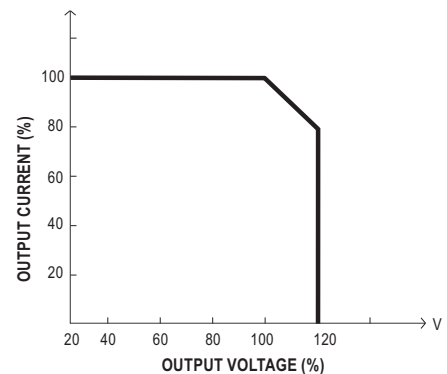
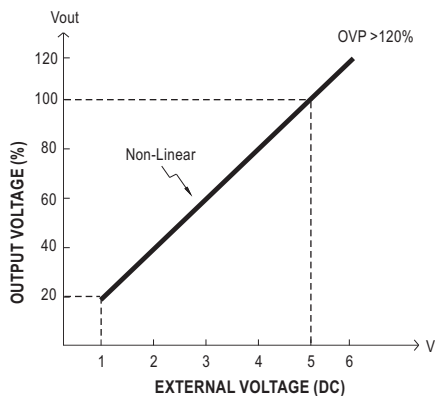

◎ Please do not adopt PWM signal as the EXTERNAL VOLTAGE.

◎ The rated current should change with the Output Voltage Programming accordingly.

※ Caution: (1) By factory default, the Output Voltage Programming is not activated, and PV(PIN3) and PS(PIN4) of CN2 are shorted by connector. Whenever this function is not needed to activate, as assumed in other sections' diagrams, please keep PV(PIN3) and PS(PIN4) of CN2 shorted; otherwise, the power supply will have no output.

(2) PV(PIN3) and PS(PIN4) of CN1 or CN2 must be disconnected if "Output Voltage Programming" function is used; otherwise, the internal electrical components may be damaged, and the power supply unit may thus be out of order.