

Immunity Levels

Test	Standard	Test Level	Criteria	Notes The power stated below is total power (main output + fan output)
ESD	EN61000-4-2	4	A	
Radiated Susceptibility	EN61000-4-3	3	A	inc proximity field requirements of EN60601-1-2:2015
Electrical Fast Transient Burst	EN61000-4-4	4	A	(AC Port, 5kHz and 100KHz)
Surge	EN61000-4-5	3	A	-
Conducted Susceptibility	EN61000-4-6	3	A	-
Magnetic fields	EN61000-4-8	4	A	-
Voltage Dips & Interruptions	EN61000-4-11 Class 3 Industrial inc EN55024 (100VAC)	0% for 1/2 cycle	A	-
		0% for 1 cycle	A	-
		40% for 10/12 cycles	B	-
		70% for 25/30 cycles	A	-
		80% for 250/300 cycles	A	-
		0% for 250/300 cycles	B	-
	EN61000-4-11 Class 3 Industrial inc EN55024 (240VAC)	0% for 1/2 cycle	A	-
		0% for 1 cycle	A	-
		40% for 10/12 cycles	A	-
		70% for 25/30 cycles	A	-
		80% for 250/300 cycles	A	-
		0% for 250/300 cycles	B	-
	EN60601-1-2:2015 (100VAC)	0% for 1/2 cycle	A	-
		0% for 1 cycle	A	-
		70% for 25/30 cycles	A	-
	EN60601-1-2:2015 (240VAC)	0% for 250/300 cycles	B	-
0% for 1/2 cycle		A	-	
0% for 1 cycle		A	-	
70% for 25/30 cycles		A	-	
		0% for 250/300 cycles	B	-
Ringwave Test	EN61000-4-12	3	A	-
Voltage Fluctuations	EN61000-4-14	Class 3	A	-

Criteria A definition: the output stays within +/-5% of regulation

Outline drawing CUS100ME (Open Frame unit)

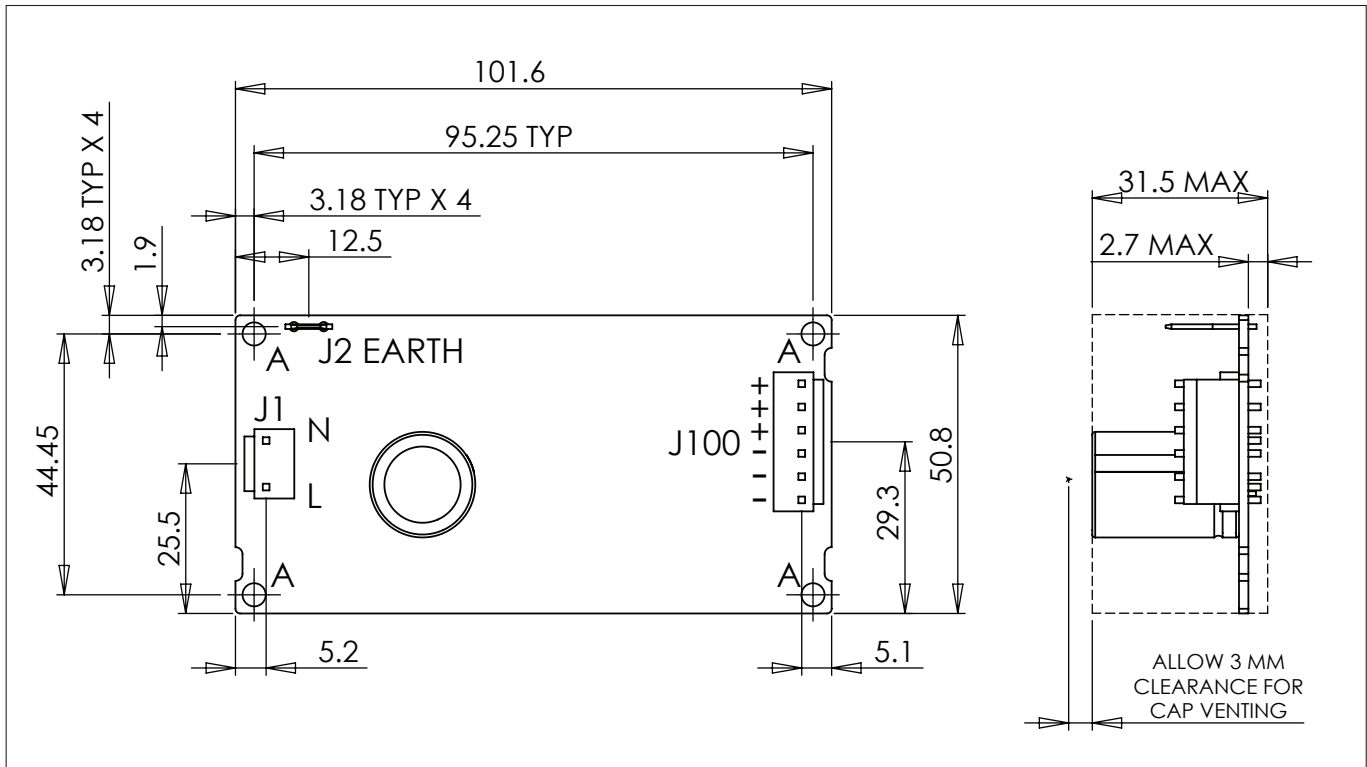

Outline drawing CUS100ME/U (U Channel) Option

