

GLOBAL SIGNALS (-N, -N1 and -N2 Option Models)		GLOBAL SIGNALS (-N3 and -N4 Option Models)	
Remote on/off	TTL logic level high inhibits all outputs (except Standby)	ATX Remote on/off	TTL logic level high or open circuit will inhibit all outputs (except Standby)
Power Good	Open collector output (referenced to PSU 0V). Turns on to indicate ac supply is good and output 1 is within regulation.	ATX Power Good	Logic high indicates ac supply is good and output 1 is within regulation.
Standby Supply	Isolated supply, not affected by remote on/off -N option = 5V / 2A (2.5A peak) -N1 Option = 12V / 1A -N2 Option = 13.5V / 1A	Standby Supply	Common 0V with power supply. Not affected by ATX remote on/off -N3 Option = 5V / 2A -N4 Option = 12V / 1A.

IMMUNITY EN61000-6-2:2001				Criteria
Electrostatic Discharge	EN61000-4-2	Level 4	Air discharge 15kV Contact discharge 8kV Not applicable to open frame units	A
Electromagnetic Field	EN61000-4-3	Level 3	(12V/m)	A
Fast / Burst Transient	EN61000-4-4	Level 4	ac input tested to 4.4kV dc output tested to 2.2kV	A
Surge Immunity	EN61000-4-5	Level 3	Common mode - 2.2kV Differential - 1.1kV	A
Conducted RF Immunity	EN61000-4-6	Level 3	(12V)	A
Power Frequency Magnetic Field	EN61000-4-8	Level 4	(30A/m)	A
Voltage Dips, Variations, Interruptions	EN61000-4-11	Class 3	Criteria B for 5 sec interruption	A

EMISSIONS EN61000-6-3:2001, EN60601-1-2:2001		
Radiated Electric Field	EN55011, EN55022	(as per CISPR.11/22) Class B, FCC47 part 15 subpart B see application note for details. Additional filtering required for IEC inlet version.
Conducted Emissions	EN55011, EN55022	(as per CISPR.11/22) Class B, FCC47 part 15 subpart B
Conducted Harmonics	EN61000-3-2	Class A
Flicker	EN61000-3-3	Compliant - d _{max} only

ENVIRONMENT	
Temperature	0°C to 50°C operational, -40°C to 70°C storage (max 12 months). Full load, with either 'F' option fitted or 2m/s air blown from input to output (approximately 10CFM)
Convection Rating	See Application note for details
Derating	50°C to 70°C derate each output by 2.5% per °C
Low Temp Startup	-20°C
Humidity	5 - 95% RH non condensing
Shock	±3 x 30g shocks in each plane, total 18 shocks 30g shock = 11ms (+/-0.5msec), half sine Conforms to EN60068-2-27, EN60068-2-47, IEC68-2-27, IEC68-2-47, JIS C0041-1987. Conforms to MIL-STD-810E/F, Method 516.5, Pro I, IV, VI
Vibration	Single axis 10 - 500 Hz at 2g (sweep and endurance at resonance) in all 3 planes Conforms to EN60068-2-6, IEC68-2-6 Conforms to MIL-STD-810E, Method 514.4, Pro I, Cat 1,9
Altitude	3,000 metres operational
Pollution	Degree 2, Material group IIIb

SAFETY APPROVALS					
	Date	Amendments		Date	Amendments
EN 60950-1	2006		EN 61010-1	2001	
UL 60950-1	2007		IEC 61010-1*	2001	
CSA 22.2 No 60950-1	2003		IEC 60601-1*	1988	
IEC 60950-1*	2005		EN 60601-1	1990	A1, A2
CE Mark	LV Directive 2006/95/EC (EN60950-1)		UL 60601-1	2003	with revisions 2006
* CB certificate and Report available on request			Check with factory for status of approvals		

OUTLINE & CONNECTION DRAWINGS

All drawings relate to both 175W and 180W versions

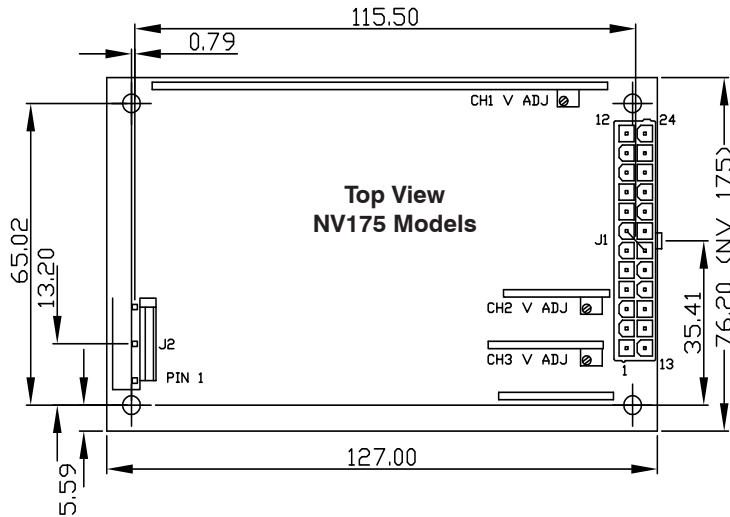

J2

PIN	FUNCTION
1	EARTH
2	NOT CONNECTED
3	LIVE
4	NOT CONNECTED
5	NEUTRAL

J1

PIN	FUNCTION	PIN	FUNCTION
12	STANDBY +Ve	24	STANDBY RETURN
11	POWER GOOD	23	REMOTE ON/OFF
10	CH1 OUTPUT	22	CH1 POWER GOOD
9	CH1 OUTPUT	21	CH1 OUTPUT
8	CH1 OUTPUT	20	CH1 OUTPUT
7	+SENSE CH1	19	-SENSE CH1
6	0V COMMON	18	0V COMMON
5	0V COMMON	17	0V COMMON
4	CH2 OUTPUT	16	0V COMMON
3	CH2 OUTPUT	15	CH2 OUTPUT
2	+SENSE CH2	14	-SENSE CH2
1	CH3 OUTPUT	13	CH4 OUTPUT

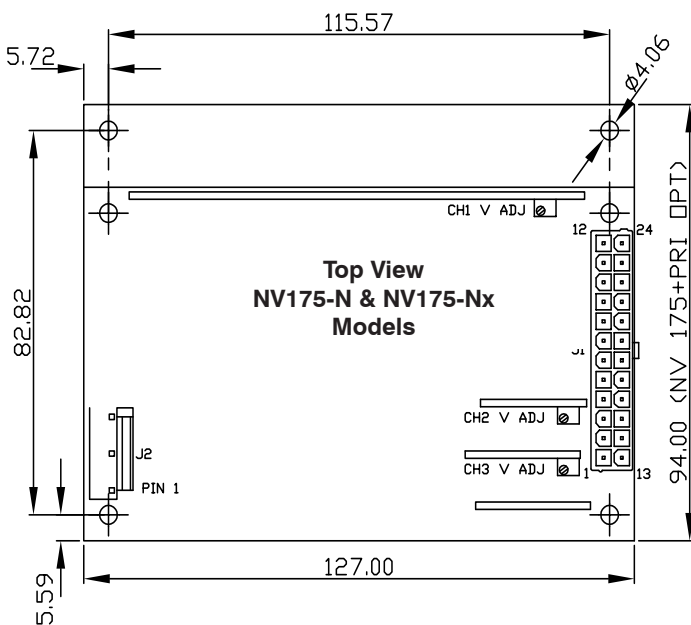

MATING PARTS (MOLEX OR EQUIVALENT)

CONN	HOUSING	PINS
J1	39-01-2245	44476-3112
J2	09-50-8051	08-52-0113

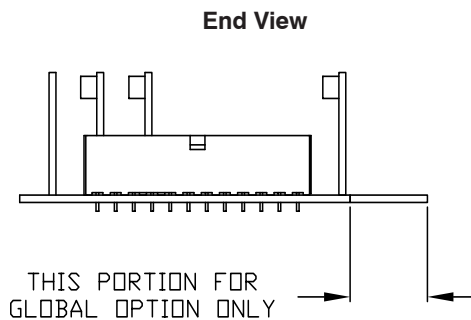
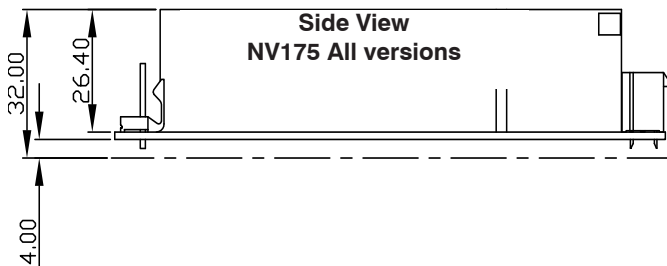

Notes 1. All customer fixings M3

2. Maximum Penetration 4.5mm

3. Maximum torque 0.9Nm

4. All tolerances +/-0.5mm