

Global Signals (-N, -N1 and -N2 option models)	
Remote on/off	TTL logic level high inhibits all outputs (except Standby)
Power Good	Open collector output (referenced to PSU 0V). Turns on to indicate ac supply is good and output 1 is within regulation.
Standby Supply	Isolated supply, not affected by remote on/off -N option = 5V / 2A (2.5A peak) -N1 Option = 12V / 1A -N2 Option = 13.5V / 1A

Global Signals (-N3 and -N4 option models)	
ATX Remote on/off	TTL logic level high or open circuit inhibits all outputs (except Standby)
ATX Power Good	Logic high indicates ac supply is good and output 1 is within regulation.
Standby Supply	Common 0V with power supply. Not affected by ATX remote on/off -N3 option = 5V / 2A -N4 Option = 12V / 1A

Immunity EN61000-6-2:2005, EN60601-1-2:2007				Criteria
Electrostatic Discharge	EN61000-4-2	Level 4	Air discharge 15kV, Contact discharge 8kV. Not applicable to open frame units	A
Electromagnetic Field	EN61000-4-3	Level 3	12V/m	A
Fast / Burst Transient	EN61000-4-4	Level 4	ac input tested to 4.4kV dc output tested to 2.2kV	A
Surge Immunity	EN61000-4-5	Level 3	Common mode - 2.2kV, Differential - 1.1kV	A
Conducted RF Immunity	EN61000-4-6	Level 3	12V	A
Power Frequency Magnetic Field	EN61000-4-8	Level 4	30A/m	A
Voltage Dips, Variations, Interruptions	EN61000-4-11	Class 3	Criteria B for 5 sec interruption and dips to 40% for 5 cycles below 154Vac nominal input	A

Emissions EN61000-6-3:2007, EN60601-1-2:2007			
Radiated Electric Field	EN55011, EN55022	(as per CISPR.11/22) Class B, FCC47 part 15 subpart B see application note for details. Additional filtering is required for IEC inlet version	
Conducted Emissions	EN55011, EN55022	(as per CISPR.11/22) Class B, FCC47 part 15 subpart B	
Conducted Harmonics	EN61000-3-2	Class A	
Flicker	EN61000-3-3	Compliant - d_{max} only	

Environment	
Temperature	0°C to 50°C operational, -40°C to 70°C storage (max 12 months). Full load, with either 'F' option fitted or 2m/s air blown from input to output (approximately 10CFM)
Derating	50°C to 70°C derate each output by 2.5% per °C
Low Temp Startup	-20°C
Humidity	5 - 95% RH non condensing
Shock	±3 x 30g shocks in each plane, total 18 shocks 30g shock = 11ms (+/-0.5msec), half sine Conforms to EN60068-2-27, EN60068-2-47, IEC68-2-27, IEC68-2-47, JIS C0041-1987. Conforms to MIL-STD-810E/F, Method 516.5, Pro I, IV, VI
Vibration	Single axis 10 - 500 Hz at 2g (sweep and endurance at resonance) in all 3 planes Conforms to EN60068-2-6, IEC68-2-6 Conforms to MIL-STD-810E, Method 514.4, Pro I, Cat 1,9
Altitude	3000 metres operational
Pollution	Degree 2, Material group IIIb

Approvals / Accreditations	
IEC/EN 60950-1, UL60950-1 / CSA 22.2 No 60950-1	File E135494
IEC/EN 60601-1, UL/CSA 60601-1, ANSI/AAMI ES60601-1 CAN/CSA-C22.2 No 60601-1-08	File E349607
IEC/EN61010	File E331788
CE Mark (EN60950-1)	LV Directive 2006/95/EC
CB certificate and Report available on request	<i>Please check with technical sales for status of approvals</i>
Designed and manufactured under the control of ISO9001 and ISO13485 (including risk management).	

Outline & Connection Drawings

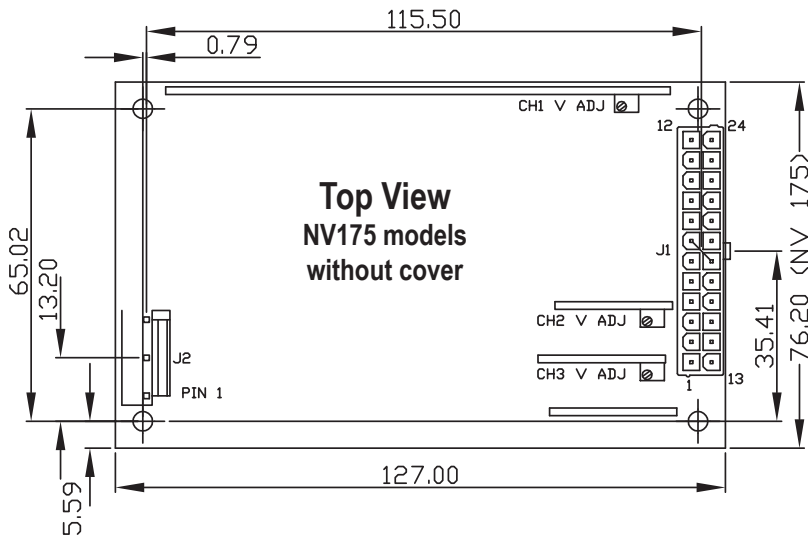

J2

PIN	FUNCTION
1	EARTH
2	NOT CONNECTED
3	LIVE
4	NOT CONNECTED
5	NEUTRAL

J1

PIN	FUNCTION	PIN	FUNCTION
12	STANDBY +Ve	24	STANDBY RETURN
11	POWER GOOD	23	REMOTE ON/OFF
10	CH1 OUTPUT	22	CH1 GOOD
9	CH1 OUTPUT	21	CH1 OUTPUT
8	CH1 OUTPUT	20	CH1 OUTPUT
7	+SENSE CH1	19	-SENSE CH1
6	0V COMMON	18	0V COMMON
5	0V COMMON	17	0V COMMON
4	CH2 OUTPUT	16	0V COMMON
3	CH2 OUTPUT	15	CH2 OUTPUT
2	+SENSE CH2	14	-SENSE CH2
1	CH3 OUTPUT	13	CH4 OUTPUT

MATING PARTS (MOLEX OR EQUIVALENT)

CONN	HOUSING	PINS
J1	39-01-2245	44476-3112
J2	09-50-8051	08-52-0113

Input and output connectors are not included with the product. They are available from TDK-Lambda

Part Number	Contents
94910	1 off input connector and 3 crimps
94911	1 off output connector and 24 crimps

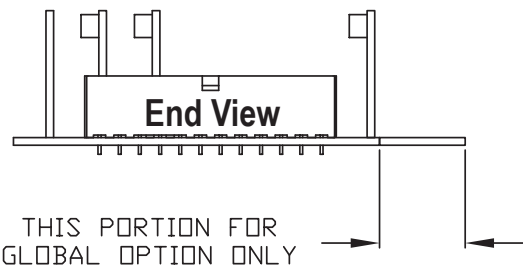
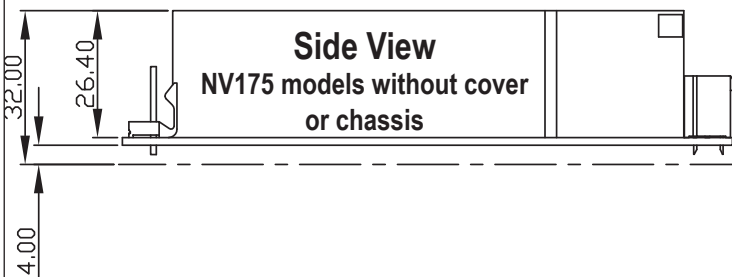
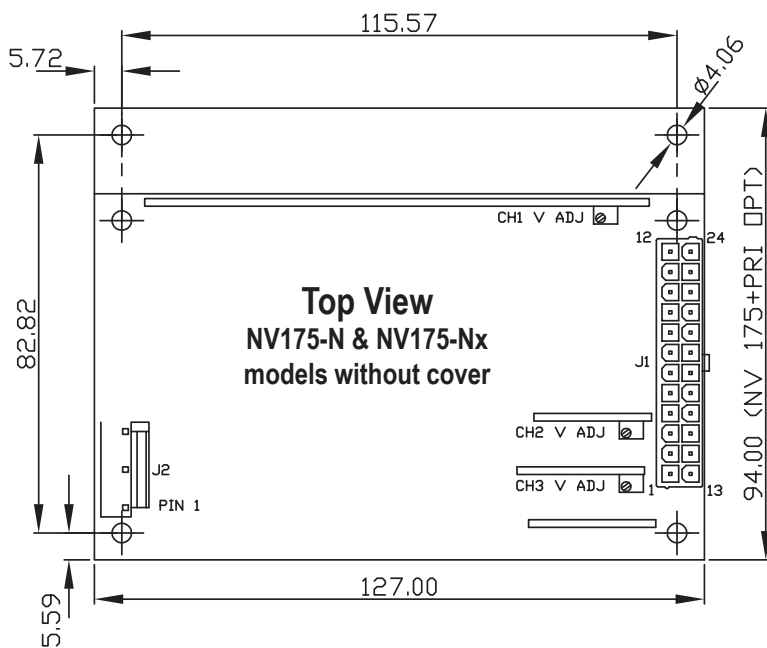

Notes: 1. All customer fixings M3

2. Maximum thread penetration 4.5mm

3. Maximum torque 0.9Nm

4. All tolerances +/-0.5mm