

General

Characteristic	Minimum	Typical	Maximum	Units	Notes & Conditions
Efficiency		93-94		%	230 VAC full load
Isolation: Input to Output Input to Ground Output to Ground	4000			VAC	2 x MOPP
	1500			VAC	1 X MOPP
	500			VDC	
Switching Frequency	60		300	kHz	PFC
		75		kHz	Main converter
		70		kHz	Standby
Power Density			9.1	W/in ³	
Mean Time Between Failure		172		kHrs	MIL-HDBK-217F, Notice 2 +25 °C GB
Weight		2.12 (960)		lb (g)	CCL400PSxx
		2.46 (1115)			CCL400PSxx-C

Efficiency Vs Load

Figure 2
12 V Models

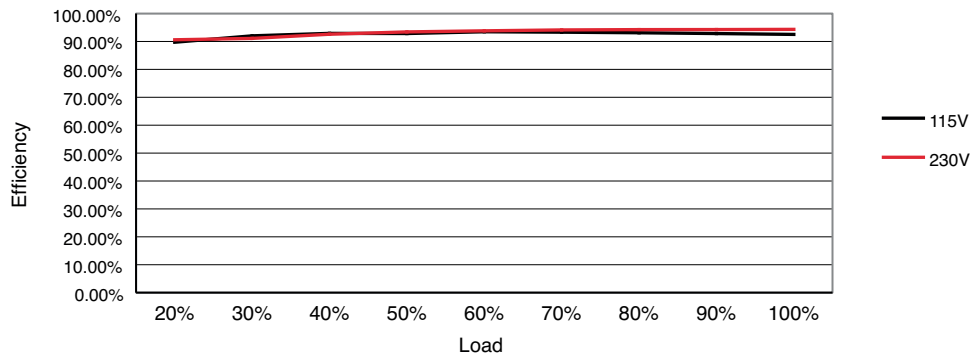

Figure 3
24 V Models

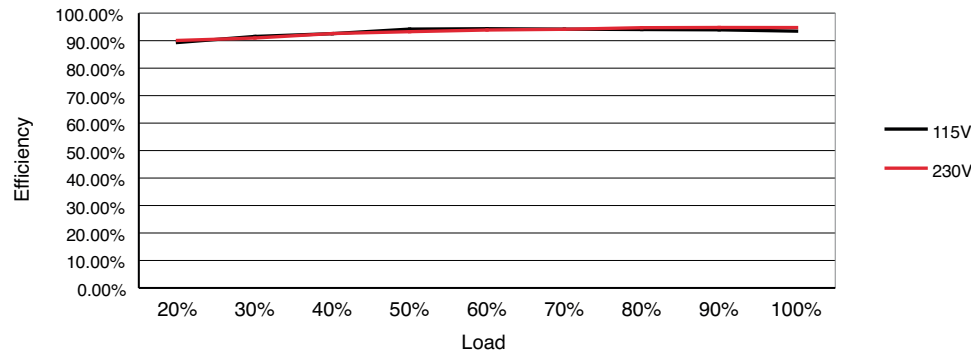
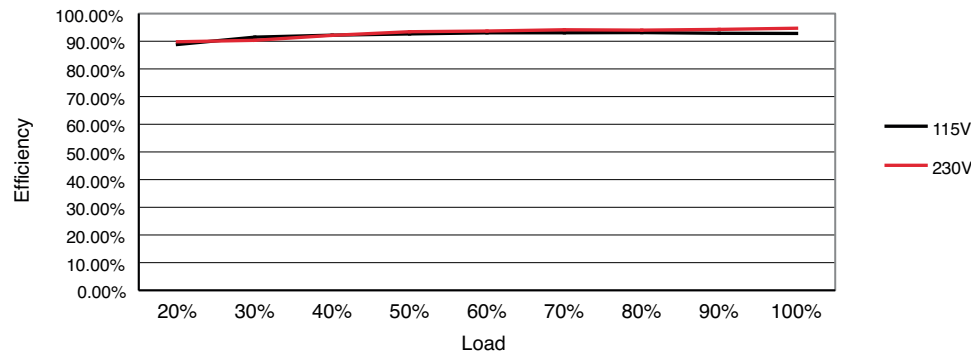

Figure 4
48 V Models



Signals & Controls

Characteristic	Notes & Conditions
Power Fail (AC-OK)	Uncommitted opto isolated transistor, normally off when AC is good (see fig.5) Provides 5 - 15ms warning of loss of output from AC failure off when AC is healthy.
Inhibit	Uncommitted isolated optocoupler diode, powered diode inhibits the supply (see fig.6 & 7)
Standby Supply	5V/0.5A Isolated supply present when AC applied.
Remote Sense	Compensates for 0.25V per lead, 0.5V total drop.

Power Fail

Figure 5

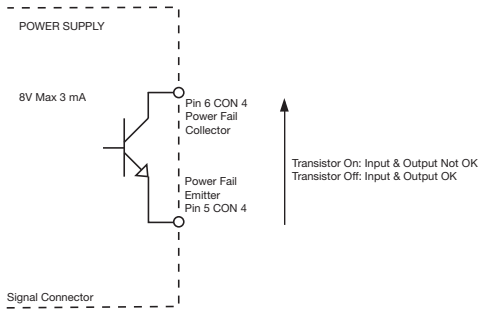

Inhibit (High)

Figure 6

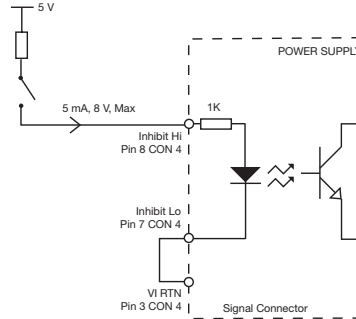

Inhibit (Low)

Figure 7

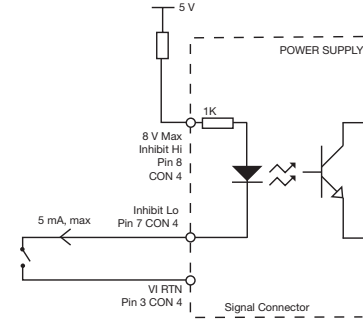

Environmental

Characteristic	Minimum	Typical	Maximum	Units	Notes & Conditions
Operating Temperature	-40		+70	°C	See derating curve, fig.8. and Thermal Considerations on page 8.
Storage Temperature	-40		+85	°C	
Cooling					Convection or conduction-cooled with 0.5 °C/W or better heatsink
Humidity			95	%RH	Non-condensing
Operating Altitude			5000	m	
Shock	±3 x 30g shocks in each plane, total 18 shocks. 30g = 11ms (±0.5msec), half sine. Conforms to EN60068-2-27 & EN60068-2-47				
Vibration	Single axis 10 - 500 Hz at 2g sweep and endurance at resonance in all 3 planes. Conforms to EN60068-2-6				

Temperature Derating Curve

Figure 8 - No Cover Fitted

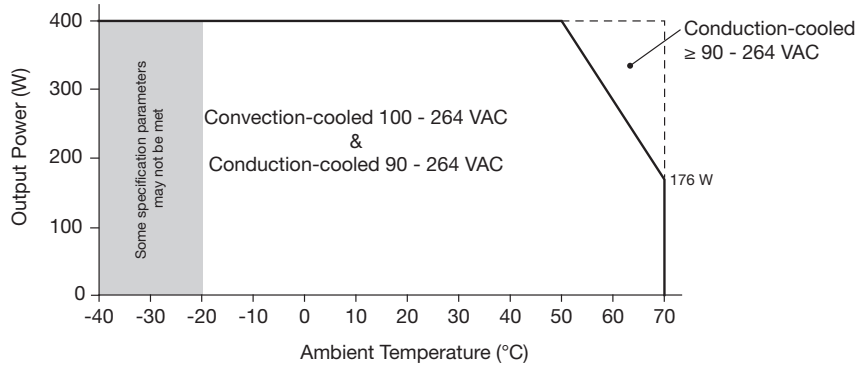

Figure 9 - Cover Fitted

