

Models and Ratings

Output Voltage V1	Output Current V1	Fan Supply V2 ⁽⁴⁾	Standby Supply V3	Output Power ⁽³⁾	Model Number ^(1,2)
12 V	50.0 A	12 V / 0.5 A	5 V / 0.2 A	607 W	SHP650PS12-EF
15 V	40.0 A	12 V / 0.5 A	5 V / 0.2 A	607 W	SHP650PS15-EF
24 V	27.0 A	12 V / 0.5 A	5 V / 0.2 A	655 W	SHP650PS24-EF
28 V	23.0 A	12 V / 0.5 A	5 V / 0.2 A	655 W	SHP650PS28-EF
36 V	18.0 A	12 V / 0.5 A	5 V / 0.2 A	655 W	SHP650PS36-EF
48 V	13.5 A	12 V / 0.5 A	5 V / 0.2 A	655 W	SHP650PS48-EF

Notes

- For top fan version replace '-EF' in model number with '-TF', e.g. SHP650PS12-TF
- For U Channel version remove suffix.

- U Channel models require a minimum of 5.5 m/s airflow from the system.
- Not available for '-TF' and '-EF' models as used by integral fan.

Mechanical Details

End Fan (See Longform Datasheet for U-Channel Version)

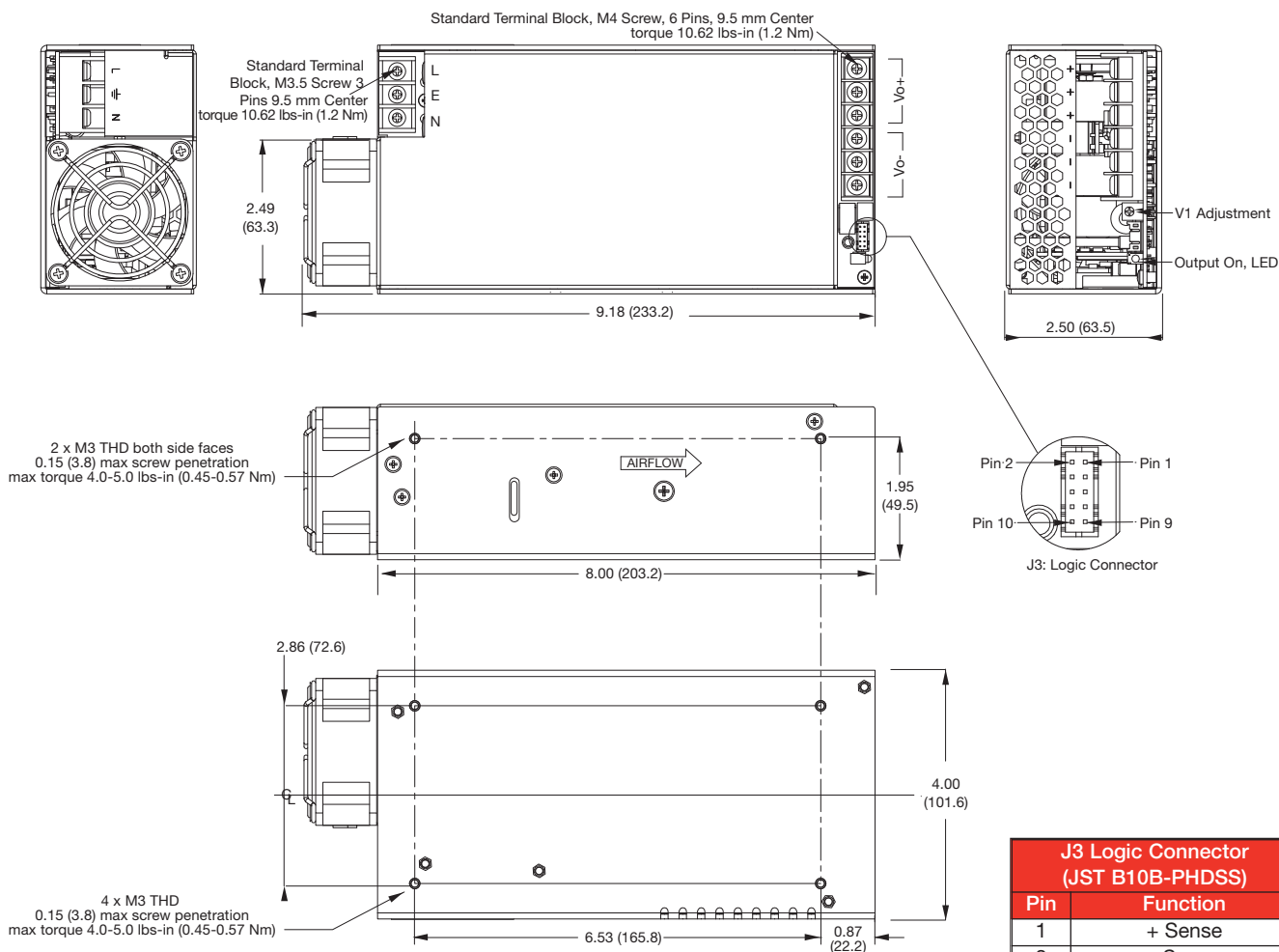

J3 Logic Connector (JST B10B-PHDSS)	
Pin	Function
1	+ Sense
2	- Sense
3	AC OK/Power Fail
4	- Sense
5	Current Share
6	Current Share
7	+ Inhibit
8	- Inhibit
9	+5 V Standby (V3)
10	5 V Standby Return (V3)

Notes

- Dimensions shown in inches (mm).
- Weight: 2.8 lb (1.27 kg).

- J3 Mating Plug: JST part no. PHR-2, contact: JST part no. SPH-002T-P0.5S; J3 Mating Plug: JST part no. PHDR-10VS, contact: 26-22AWG JST part no. SPHD-001T-P0.5

Mechanical Details

Top Fan (Suffix -TF)

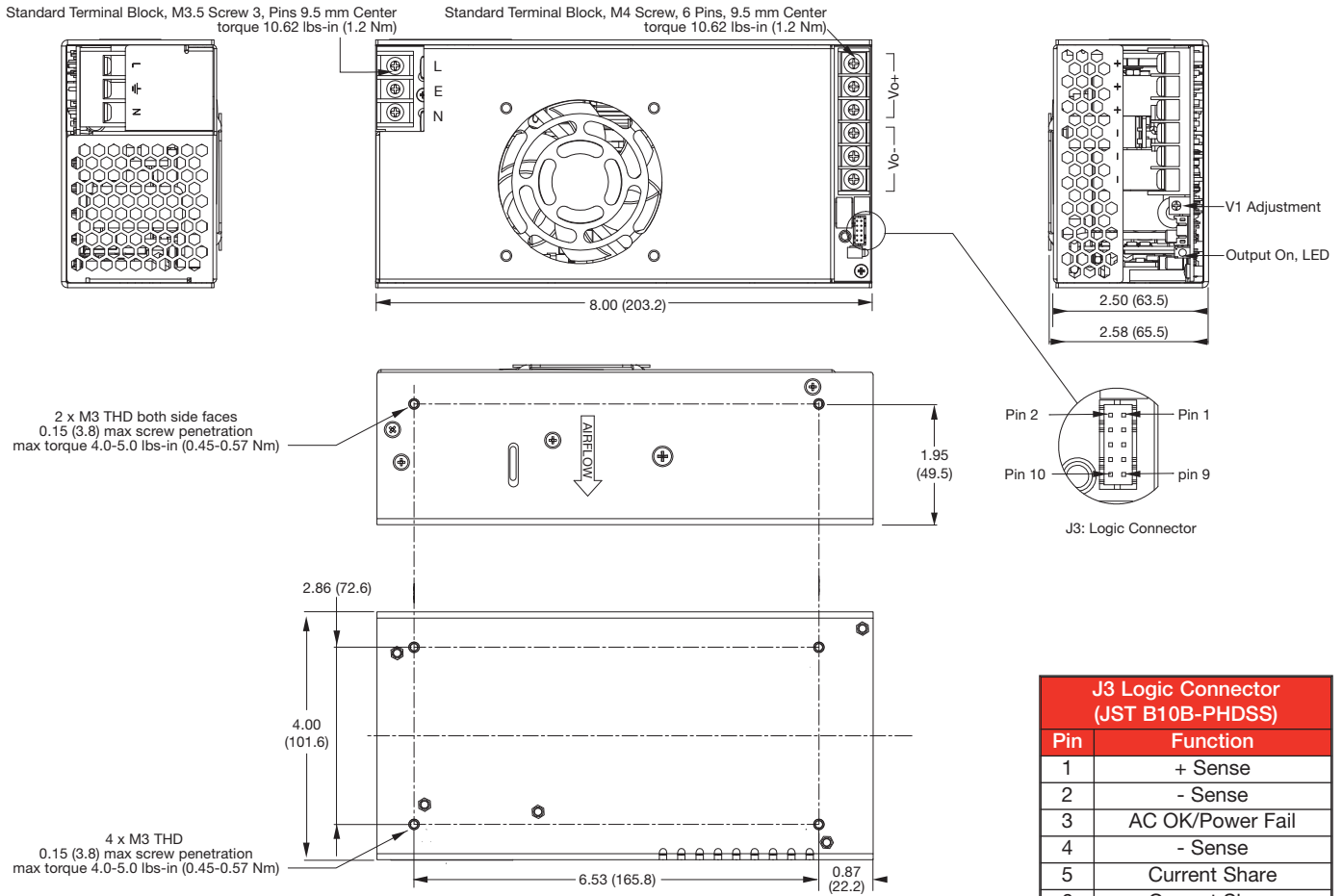

J3 Logic Connector (JST B10B-PHDSS)	
Pin	Function
1	+ Sense
2	- Sense
3	AC OK/Power Fail
4	- Sense
5	Current Share
6	Current Share
7	+ Inhibit
8	- Inhibit
9	+5 V Standby (V3)
10	5 V Standby Return (V3)

Notes

- Dimensions shown in inches (mm).
- Weight: 2.8 lb (1.27 kg).
- J3 Mating plug: JST part no. PHDR-10VS, contact: 26-22 AWG JST part no. SPHD-001T-P0.5.

Signals

AC OK/Power Fail

Remote On/Off (Inhibit)

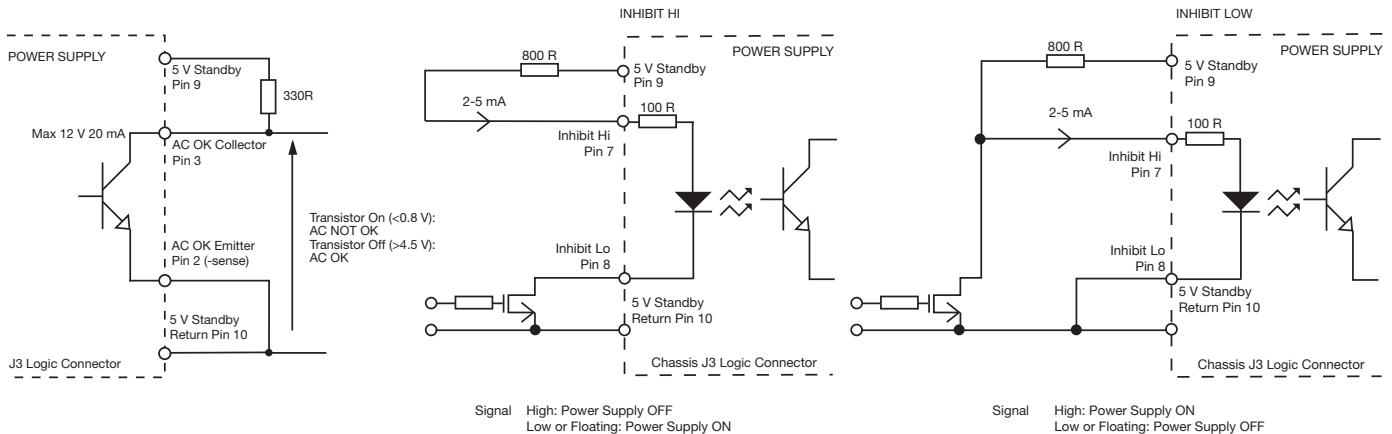

For U Channel and Thermal Considerations please see longform datasheet.