



iX Panel T60

Installation Manual

English

Installation manual for iX Panel T60

Foreword

All iX Panels are developed to satisfy the demands of human-machine communication. Built-in functions such as displaying and controlling text, dynamic indication, time channels, alarm and recipe handling are included.

The operator panel works primarily in an object-oriented way, making it easy to understand and use. Configuration is carried out on a PC using the iX Developer configuration tool. The project can then be transferred and stored in the operator panel itself.

Various types of automation equipment such PLCs, servos or drives can be connected to the iX Panels. In this manual, the term “the controller” refers to the connected equipment.

This manual explains how to install the operator panel. Please refer to the iX Developer reference manual for further information.

FCC Compliance Information

This equipment has been tested and found to comply with the limits for a Class A digital device, pursuant to part 15 of the FCC Rules. These limits are designed to provide reasonable protection against harmful interference when the equipment is operated in a commercial environment. This equipment generates, uses, and can radiate radio frequency energy and, if not installed and used in accordance with the instruction manual, may cause harmful interference to radio communications. Operation of this equipment in a residential area is likely to cause harmful interference in which case the user will be required to correct the interference at user's own expense.

Any modification to this equipment not expressly approved by QSI could void the user's authority to operate the equipment.

© Beijer Electronics AB, MAEN991A, 2010-04

The information in this document is subject to change without notice and is provided as available at the time of printing. Beijer Electronics AB reserves the right to change any information without updating this publication. Beijer Electronics AB assumes no responsibility for any errors that may appear in this document. Read the entire installation manual prior to installing and using this equipment. Only qualified personnel may install, operate or repair this equipment. Beijer Electronics AB is not responsible for modified, altered or renovated equipment. Because the equipment has a wide range of applications, users must acquire the appropriate knowledge to use the equipment properly in their specific applications. Persons responsible for the application and the equipment must themselves ensure that each application is in compliance with all relevant requirements, standards and legislation in respect to configuration and safety. Only parts and accessories manufactured according to specifications set by Beijer Electronics AB may be used.

BEIJER ELECTRONICS AB SHALL NOT BE LIABLE TO ANYONE FOR ANY DIRECT, INDIRECT, SPECIAL, INCIDENTAL OR CONSEQUENTIAL DAMAGES RESULTING FROM THE INSTALLATION, USE OR REPAIR OF THIS EQUIPMENT, WHETHER ARISING IN TORT, CONTRACT, OR OTHERWISE. BUYER'S SOLE REMEDY SHALL BE THE REPAIR, REPLACEMENT, OR REFUND OF PURCHASE PRICE, AND THE CHOICE OF THE APPLICABLE REMEDY SHALL BE AT THE SOLE DISCRETION OF BEIJER ELECTRONICS AB.

Contents

1	Safety Precautions	4
1.1	General	4
1.2	During Installation	4
1.3	During Use	5
1.4	Service and Maintenance	5
1.5	Dismantling and Scrapping	5
2	Installation	6
2.1	Space Requirements	6
2.2	Installation Process	6
2.2.1	Mode Switches	9
2.2.2	Connections to the Controller	9
2.2.3	Other Connections and Peripherals	9
3	Technical Data	10
4	Chemical Resistance	11
4.1	Metal Casing	11
4.2	Touch Screen and Overlay	12
4.2.1	Autotex F157/207	12
4.2.2	Touch Screen Surface	13
4.2.3	Autoflex EB	13
5	Operator Panel Drawings	14
5.1	Communication Ports	14
5.2	iX Panel T60 Outline	15
6	Additional Installation Tips	16
6.1	Grounding the Operator Panel	16
6.2	Ethernet Connection in the Panel	17
6.3	To Achieve Better EMC Protection	18
6.4	Ambient Temperature	19
6.5	Safety	20
6.6	Galvanic Isolation	21
6.7	Cable and Bus Termination RS485	22

1 Safety Precautions

Both the installer and the owner and/or operator of the operator panel must read and understand this installation manual.

1.1 General

- Read the safety precautions carefully.
- Check the delivery for transportation damage. If damage is found, notify the supplier as soon as possible.
- Do not use the operator panel in an environment with high explosive hazards.
- The supplier is not responsible for modified, altered or reconstructed equipment.
- Use only parts and accessories manufactured according to specifications of the supplier.
- Read the installation and operating instructions carefully before installing, using or repairing the operator panel.
- Never allow fluids, metal filings or wiring debris to enter any openings in the operator panel. This may cause fire or electrical shock.
- Only qualified personnel may operate the operator panel.
- Storing the operator panel where the temperature is lower/higher than recommended in this manual can cause the LCD display liquid to congeal/become isotopic.
- The LCD display liquid contains a powerful irritant. In case of skin contact, wash immediately with plenty of water. In case of eye contact, hold the eye open, flush with plenty of water and get medical attention.
- The figures in this manual serves an illustrative purpose. Because of the many variables associated with any particular installation, the supplier cannot assume responsibility for actual use based on the figures.
- The supplier neither guarantees that the operator panel is suitable for your particular application, nor assumes responsibility for your product design, installation or operation.

1.2 During Installation

- The operator panel is designed for stationary installation on a plane surface, where the following conditions are fulfilled:
 - no high explosive risks
 - no strong magnetic fields
 - no direct sunlight
 - no large, sudden temperature changes
- Install the product according to the accompanying installation instructions.
- Ground the product according to the accompanying installation instructions.
- Only qualified personnel may install the operator panel.
- Separate the high voltage, signal and supply cables.
- Make sure that the voltage and polarity of the power source is correct before connecting the product to the power outlet.
- Peripheral equipment must be appropriate for the application and location.

1.3 During Use

- Keep the operator panel clean.
- Emergency stop and other safety functions may not be controlled from the operator panel.
- Do not use too much force or sharp objects when touching the keys, touch screen etc.

1.4 Service and Maintenance

- Only qualified personnel should carry out repairs.
- The agreed warranty applies.
- Before carrying out any cleaning or maintenance operations, disconnect the equipment from the electrical supply.
- Clean the display and surrounding front cover with a soft cloth and mild detergent.
- Replacing the battery incorrectly may result in explosion. Only use batteries recommended by the supplier.

1.5 Dismantling and Scrapping

- The operator panel or parts thereof shall be recycled according to local regulations.
- The following components contain substances that might be hazardous to health and the environment: lithium battery, electrolytic capacitor and display.

2 Installation

2.1 Space Requirements

- Installation plate thickness: 1.5 - 7.5 mm (0.06 - 0.3 inch)
- Space requirements when installing the operator panel:

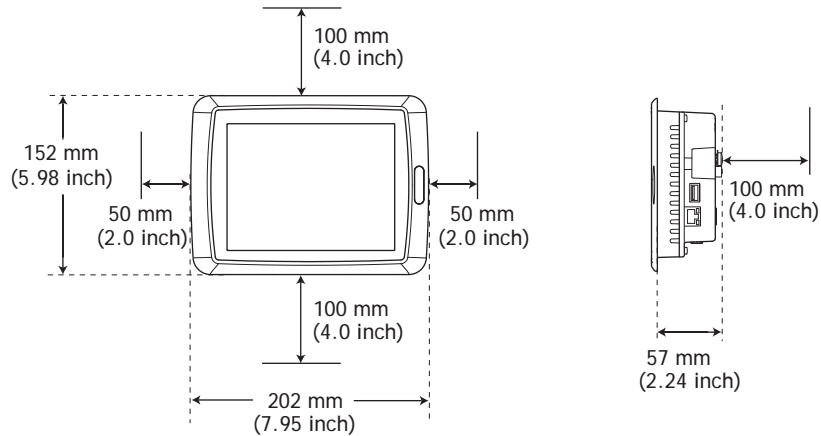

Caution:

The openings on the enclosure are for air convection. Do not cover these openings.

2.2 Installation Process

1. Unpack and check the delivery. If damage is found, notify the supplier.

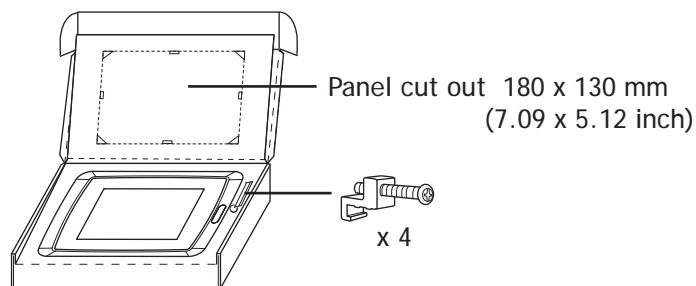

Note:

Place the operator panel on a stable surface during installation. Dropping it or letting it fall may cause damage.

2. Place the panel cut out where the operator panel is to be situated, draw along the outer sides of the holes and cut according to the markings.

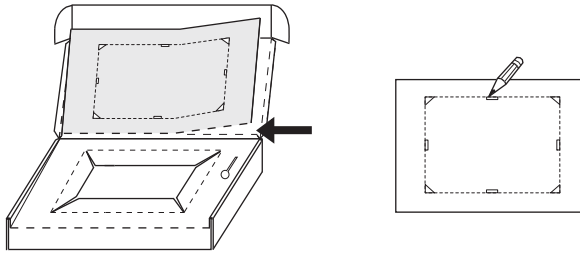

3. Secure the operator panel in position, using all the fastening holes and the provided brackets and screws:

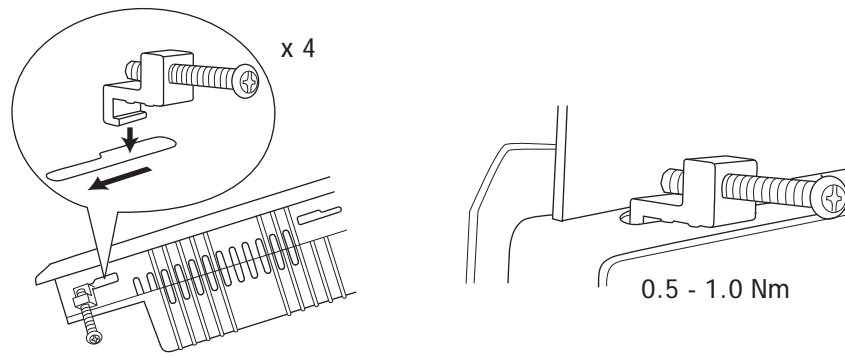

4. Connect the cables in the specified order, according to the drawing and steps below.

Caution:

- Ensure that the operator panel and the controller system have the same electrical grounding (reference voltage level), otherwise errors in communication may occur.
 - The operator panel must be brought to ambient temperature before it is started up. If condensation forms, ensure that the operator panel is dry before connecting it to the power outlet.
 - Ensure that the voltage and polarity of the power source is correct.
 - Use only shielded communication cables.
 - Separate high voltage cables from signal and supply cables.
-

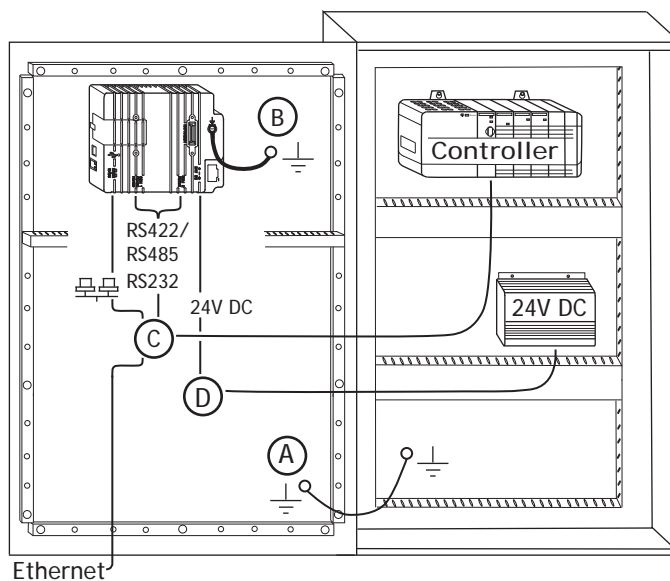

- Connect cable A.
 - Connect cable B, using an M5 screw and a grounding conductor (as short as possible) with a cross-section of minimum 2.5 mm².
 - Connect cable C.
 - Connect cable D.
5. Carefully remove the laminated film over the operator panel display, to avoid static electricity that could damage the panel.

3 Technical Data

Parameter	iX Panel T60
Front panel, W x H x D	202 x 152 x 6 mm
Mounting depth	57 mm (157 mm including clearance)
Front panel seal	IP 66
Rear panel seal	IP 20
Keyboard material/Front panel	Touch screen: Polyester on glass, 1 million finger touch operations. Overlay: Autotex F157 or F207*.
Reverse side material	Powder-coated aluminum
Weight	0.9 kg
Serial port RS422/RS485	25-pin D-sub contact, chassis-mounted female with standard locking screws 4-40 UNC
Serial port RS232C	9-pin D-sub contact, male with standard locking screws 4-40 UNC
Ethernet	Shielded RJ 45
USB	Host type A (USB 1.1), max output current 500 mA
Real time clock	±20 PPM + error because of ambient temperature and supply voltage. Total maximum error: 1 min/month at 25 °C. Temperature coefficient: -0.034±0.006 ppm/°C ²
Real time clock battery	CR2450 (UL and cUL: Sanyo or Panasonic) Minimum lifetime: 3 years
Power consumption at rated voltage	Normal: 0.2 A Maximum: 0.4 A
Display	TFT-LCD. 320 x 240 pixels, 64K colors. LED backlight lifetime at the ambient temperature of +25 °C: >20,000 h.
Active area of display, W x H	115.2 x 86.4 mm
Fuse	Internal DC fuse, 2.0 AT, 5 x 20 mm
Power supply	+24 V DC (20 - 30 V DC). Power supply connector. CE: The power supply must conform with the requirements according to IEC 60950 and IEC 61558-2-4. UL and cUL: The power supply must conform with the requirements for class II power supplies.
Ambient temperature	Vertical installation: 0 ° to +50 °C Horizontal installation: 0 ° to +40 °C
Storage temperature	-20 ° to +70 °C
Relative humidity	5 - 85 % non-condensed
Approvals and certifications	Information is available on the web site www.beijerelectronics.com

* See section [Chemical Resistance](#) for more information.

4 Chemical Resistance

4.1 Metal Casing

The frame and casing material is powder-coated aluminum. This powder paint withstands exposure to the following chemicals without visible change:

Acetic acid 10%	Phosphoric acid 4%
Citric acid 10%	Phosphoric acid 10%
Diesel	Sea water
Distilled water	Sodium chloride 2%
Edible oil	Sodium chloride 20%
Fuel oil	Sulphuric acid 20%
Hydrogen peroxide 3%	Tap water

The powder paint shows limited resistance to the following chemicals at room temperature:

Butanol	Nitric acid 3%
Hydrochloric acid 5%	Nitric acid 10%
Isopropyl alcohol	Phosphoric acid 43%
Na-hypochlorite 10%	Turpentine

Note:

If exposure to any of the above chemicals is demanded, it is recommended to first test the chemical on an "invisible" spot of the metal casing.

The powder paint shows little or no resistance to the following chemicals at room temperature:

Acetic acid, conc.	Methyl-ethyl ketone	Toluene
Acetone	Nitric acid 30%	Trichlorethylene
Ammonia 5%	Phenol	Xylene
Ammonia, conc.	Sodium hydroxide 5%	97 octan unleaded petrol
Ethyl acetate	Sodium hydroxide 30%	98 octan leaded petrol

4.2 Touch Screen and Overlay

4.2.1 Autotex F157/207

Autotex F157 or F207 covers the overlay surrounding the touch screen.

Solvent Resistance

Autotex F157/F207 withstands exposure of more than 24 hours duration under DIN 42 115 Part 2 to the following chemicals without visible change:

Acetonitrile	Diesel Downey / Lenor ¹	Phosphoric acid (<30%)
Ajax / Vim in solution	Ethanol	Potassium ferricyanide
Alkalicarbonate solution ¹	Glycerine	Potassium hydroxide (<30%)
Ammonia (<40%) ¹	Glycol	Pure Turpentine
Acetic acid (<50%)	Gumption ¹	SBP 60/95 ¹
Ariel powder in solution ¹	Hydrochloric acid (<36%)	Sulfuric acid (<10%)
Bleach ¹	Linseed oil	Tomato ketchup
Castor oil	Methanol	Trichloroacetic acid (<50%)
Caustic soda (<40%) ¹	Nitric acid (<10%)	White Spirit
Cutting oil	Paraffin oil	Windex ¹
Cyclohexanol	Persil powder in solution ¹	Wisk
Diacetone alcohol	Petroleum spirit ¹	-

¹ Extremely faint glossing of the texture was noted.

Autotex withstands DIN 42 115 Part 2 exposure of up to 1 hour duration to glacial acetic acid without visible change.

Autotex is not resistant to high pressure steam at over 100 °C or the following chemicals:

Concentrated mineral acids	Benzyl alcohol
Concentrated caustic solution	Methylene chloride

Outdoor Use

In common with all polyester based films Autotex F157/F207 is not suitable for use in conditions of long term exposure to direct sunlight.

4.2.2 Touch Screen Surface

The touch screen surface on the panel withstands exposure to the following solvents without visible change:

Solvents	Time
Acetone	10 minutes
Isopropanol	10 minutes
Toluene	5 hours

4.2.3 Autoflex EB

It is recommended to use the Autoflex EB touch display protection film, that can be ordered from Beijer Electronics.

Solvent Resistance

Autoflex EB withstands exposure to the same chemicals as Autotex F157 or F207 according to section [Autotex F157/207](#).

Outdoor Use

In common with all polyester based films Autotex EB is not suitable for use in conditions of long term exposure to direct sunlight.

5 Operator Panel Drawings

5.1 Communication Ports

RS-232

Pin no	Signal	Signal Name	Signal direction
1	DCD	Data Carrier Detect	Input
2	RD	Receive Data	Input
3	TD	Transmit Data	Output
4	DTR	Data Terminal Ready	Output
5	SG	Signal Ground	-
6	DSR	Data Set Ready	Input
7	RTS	Request To Send	Output
8	CTS	Clear To Send	Input
9	RI	Ring Indicator	Input

RS-422/485

Pin no	RS-422		RS-485	
	Signal	Signal direction	Signal	Signal direction
2	TxD+	Output	Tx/Rx+	In/Output
15	TxD-	Output	Tx/Rx-	In/Output
3	RxD+	Input		
16	RxD-	Input		
4	RTS+	Output		
17	RTS-	Output		
5	CTS+	Input		
18	CTS-	Input		
20	1)			
21	1)			
6	Do not use		2) Bus termination	4) Connect to pin no.19 for bus-termination.
19	Do not use		3) Bus termination	See above
7,8	0V		0V	
14	+5V <100mA	Output	+5V <100mA	Output

1) Pin no 20 connected to pin no 21 internal in the terminal

2) Directly connected internally to pin no. 2 (Tx/Rx+).

3) Connected to pin no. 15 (Tx/Rx-) internally via a 120ohm 1/4W resistor.

4) NOTE! Only the first and the last unit on the bus should be terminated.

USB

Pin no	Signal	Signal direction
1	VBUS	-
2	D-	In/Output
3	D+	In/Output
4	GND	-

Frame connected to chassis.

Ethernet

Pin no	Signal	Signal direction
1	Tx+	Output
2	Tx-	Output
3	Rx+	Input
6	Rx-	Input
4,5,7,8	GND	

5.2 iXPanel T60 Outline

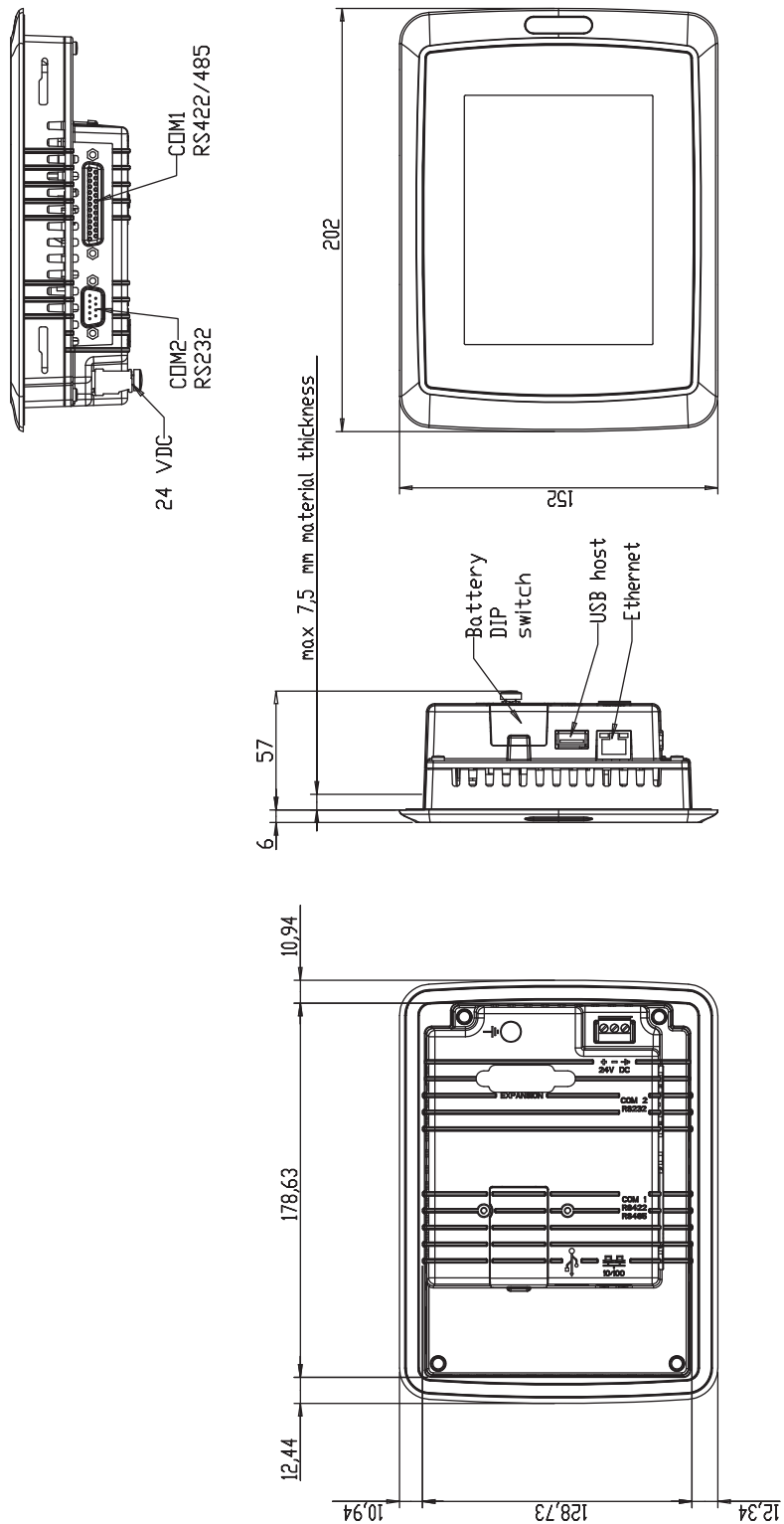

6 Additional Installation Tips

When experiencing communication problems in for example noisy environments or when operating close to temperature limits, the following recommendations are to be noticed.

6.1 Grounding the Operator Panel

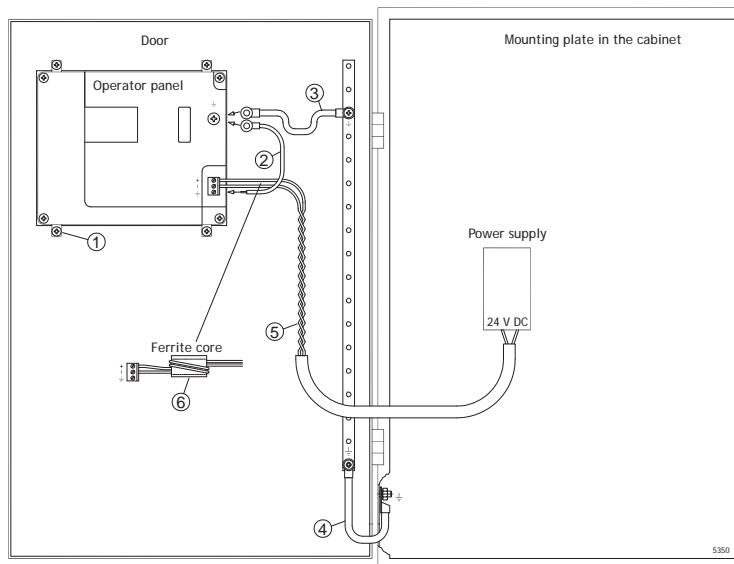

The operator panel's mounting clamps do not provide a secure grounding connection between the panel and the device cabinet, see 1 in drawing above.

1. Connect a 2.5 mm² wire between the operator panel's quick-connect plinth and the panel chassis, see 2 in drawing above.
 2. Connect a 6 or 4 mm² wire or grounding braid between the panel's chassis and the closest grounding point on the door, see 3 in drawing above.
 3. Connect a strong but short grounding braid between the door and the device cabinet, see 4 in drawing above.
 4. Twist the cables onto the 24 V DC feed, see 5 in drawing above.
 - 2 turns around the ferrite core provide 4 times the suppression of 1 turn.
 - 3 turns around the ferrite core provide 9 times the suppression of 1 turn.
- A ferrite core suppresses disturbances to the 24 V feed, see 6 in drawing above.

Note:

The grounding wires should be short and the conductor should have a large area. A long, thin grounding wire has a very high impedance (resistance) at high frequencies and will not guide disturbances to the ground. Multi-wire conductors are better than single wire conductors with the same area. A braided conductor wire with the same area is even better. The best is a short, thick grounding braid.

6.2 Ethernet Connection in the Panel

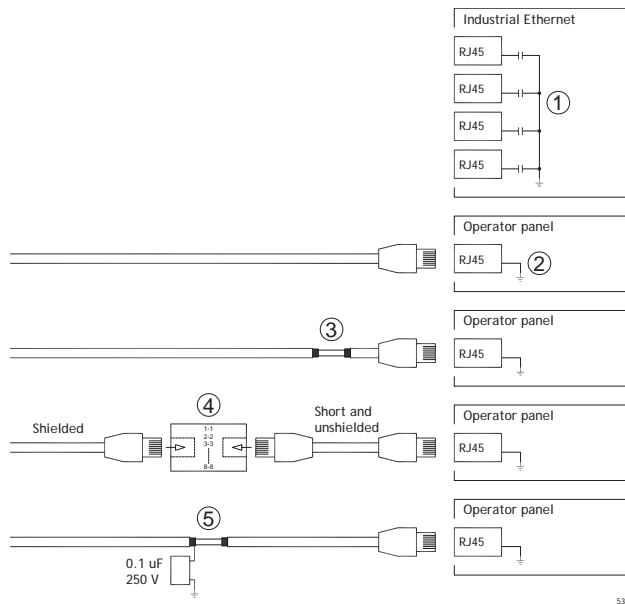

In some industrial units for Ethernet, the RJ45 contact's shield is connected to the chassis via a capacitor, see 1 in drawing above.

The operator panel's Ethernet shield is directly connected to the chassis, see 2 in drawing above.

1. Check whether the other Ethernet unit has its shield directly grounded or grounded via a capacitor.

Note:

In many cases, connecting the shielded Ethernet cabling to the chassis at both ends is inappropriate. Hum or grounding loops can occur. Unshielded cabling may even result in fewer communication errors.

A good solution may be to use a shielded Ethernet cable, but to connect the shield at one end only.

One option is to break the shield, see 3 in drawing above.

A more elegant method is to expand the shielded Ethernet cabling with a piece of unshielded Ethernet cable, see 4 in drawing above.

You can ground the shield via an external 0.1 uF/250 V plastic capacitor, see 5 in drawing above. This will connect the HF transients to the ground.

6.3 To Achieve Better EMC Protection

- Initially, use the original cabling from Beijer Electronics primarily.
- Use shielded cables for RS232 communication.
- Use twisted pair and shielded cabling for RS422 and RS485.
- Use the cabling intended for the bus type; Ethernet, Profibus, CC-Link, CAN, Device Net etc.
- Install and connect according to applicable specifications for the relevant bus standard.
- Use shielded cabling for Ethernet, preferably with foil + braided shield.
- D-sub covers should be shielded, and the shield should be connected to the cover 360° where the cable comes in.
- Connect the shield at both ends.

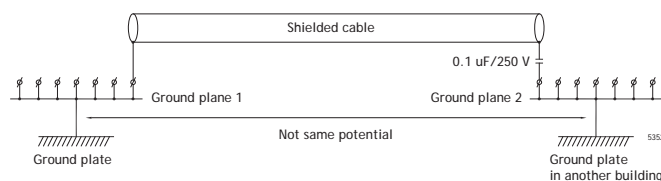

With longer distances, there is a risk that the ground potential may be different. In that case, the shield should only be connected at one end. A good alternative is to connect the other end of the shield to the ground via a 0.1 uF/250 V plastic capacitor. Both ends are then connected to the ground in terms of HF, but only connected to the ground at one end in terms of LF, thus avoiding the 50 Hz grounding loops.

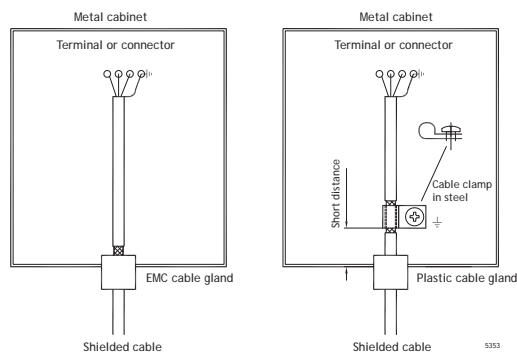

1. Use an EMC cable gland or regular plastic cable gland, remove the outer jacket and connect the shield to the installation plate with a 360° metal cable clamp.
2. Place the 24 V DC and communications cabling in one cable trunk/cable duct and 230/380 V AC in another. If the cables need to be crossed, cross them at 90° only. Avoid combining the cabling for stronger 24 V DC outputs with the communication cabling.

Ferrite cores that are snapped onto the shielded cabling may remove minor disturbances. Large ferrite pieces that are snapped onto unshielded cabling and where the wires go 2-4 times around the cores are approximately 5-25 times more efficient.

6.4 Ambient Temperature

The maximum ambient temperature for the operator panel is provided in the specifications. The ambient temperature refers to the temperature in the device cabinet which cools the panel's electronics.

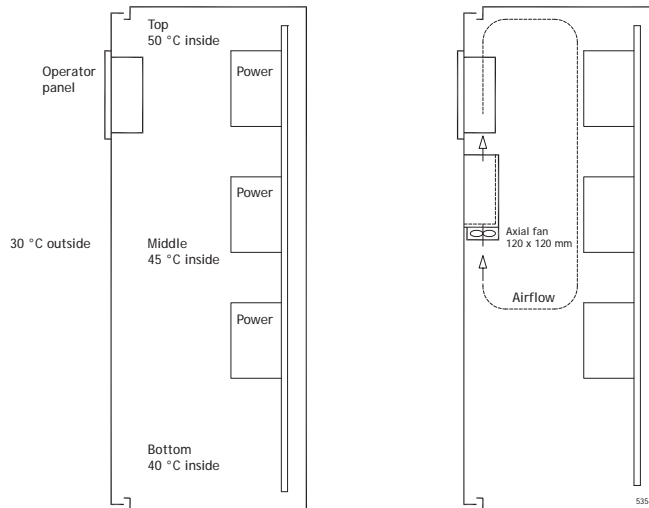

In most cases, the ambient temperature for the operator panel is significantly higher than the device cabinet's ambient temperature.

If the cabinet is tall and there are a number of heat-generating devices, the temperature at the top of the cabinet will be considerably higher than the theoretical temperature increase that would be expected. All electronics are sensitive to heat. The lifespan of an electrolytic capacitor is cut in half with an 8-10 ° increase in temperature. A 15-20 ° temperature increase results in a quarter of the lifespan etc.

Rittal has a good program for estimating the anticipated average temperature in the cabinet as well as a large program for controlling the temperature in the device cabinet.

An enamel-coated steel cabinet has a radiant heat value of 5.5 W/m² and degrees C.

Installing a fan inside the cabinet will even out the temperature, while moving air provides considerably better cooling than still air. A suitable fan is a 120 x 120 mm axial fan, available in 24 V DC, 115 and 230 V AC.

Install the fan so that it sits in the cooler area and will blow cold air against the operator panel. If the fan is mounted at the top and sucks air upwards, the fan's ambient temperature will be higher = shorter lifespan.

A good fan with a ball-bearing mounting has an expected lifespan of at least 40,000 hours (not a guaranteed lifespan) at 40 °C. This corresponds to at least 4 years of continuous use. If a thermostat is installed, the fan only needs to come on when needed.

Large graphic terminals draw only one fifth of the current when the background lighting is off. The loss effect drops from e.g. 25 W to only 5 W.

The operator panel's loss effect = supply voltage x current. Virtually no power goes to external users and no loss effects due to inputs.

6.5 Safety

Most of the operator panels are fed with 24 V DC.

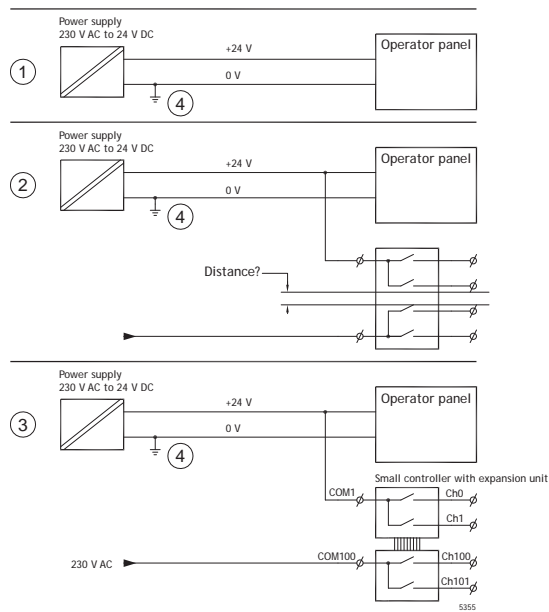

If you use a power supply that meets safety standards and only feeds the operator panel, there is no problem. See 1 in drawing above.

However, if you have a 24 V unit that also feeds other units, there is reason to be cautious, see 2 in drawing above. The operator panel does not have insulation that meets safety requirements in the event of a potential short circuit between 230 V AC and 24 V DC. It is assumed that the 24 V feed is secure, for example, SELV according to EN 60950 (protection against electric shock) and UL 950.

Example:

Here is an example that explains why a secure 24 V DC feed can be ruined by mixing 24 V relay contacts with 230 V AC relay contacts in a smaller controller. Check that the "clearances and creepage distances between 24 V DC and 230 V AC fulfill EN 60950 or UL 950". If not, input a separate 24 V unit into the operator panel.

If there is a substantial distance between the relay contacts for 24 V DC and 230 V AC, it is OK to use the same 24 V devices for all feeds. See 3 in drawing above.

Connect 0 V on the 24 V feed to the ground, see 4 in drawing above. This offers three advantages:

- Safety is increased. The 24 V feed will not be live in the event of a faulty connection or short circuit between 0 V (24 V) and 230 V phase.
- Transients on the 24 V feed are connected to the ground.
- No risk that the 24 V feed is at a high level in relationship to the ground. This is not unusual since there is high static electricity.

6.6 Galvanic Isolation

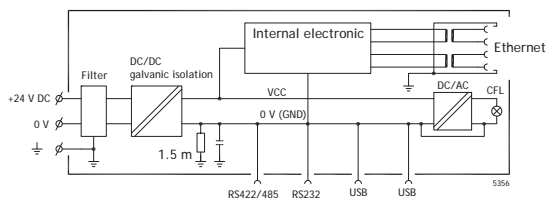

The operator panel has galvanic isolation against the 24 V DC feed but no galvanic isolation between the communication ports for RS232, RS422/485 and USB. Only the Ethernet connection has galvanic isolation.

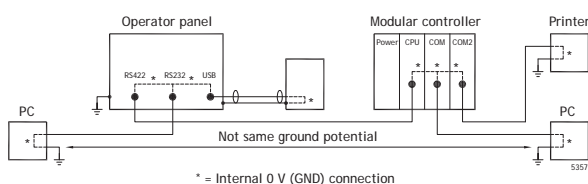

When a PC is connected to the panel, the panel's internal 0 V (GND) will be connected to the protective ground via the PC.

A number of USB devices can have the shield connected together with the protective ground. Here, the panel's 0 V (GND) is connected to the protective ground when, for example, a USB memory stick, keyboard or similar device is plugged in.

If a number of units are connected that have a 0 V and a ground connection, and these are connected to various grounding points, there is a substantial risk of problems. Grounding currents go through communication cables, the rear plate of the controller, and internally in the operator panel, and can cause errors.

Use external units to improve communication and achieve galvanic isolation. Westermo has good industry-standard insulators that are also insulated from the 24 V DC feed.

Note:

It is very important to make sure that the 24 V feed in the external insulation unit is not connected to one of the communication outlets. If it does not have 100% insulation against the 24 V feed, disturbances and grounding currents from the 0V on the 24 V side will disrupt communication.

Using this type of unit solves one problem but creates a larger problem! A substandard installation may work now, but problems may arise when other devices are connected.

6.7 Cable and Bus Termination RS485

- Use shielded and twisted pair cable. The pair capacitance may not exceed 52.5 pF/m and area at least 0.25 mm² (AWG 24), if you want to use the maximum transfer distance and maximum transfer speed.
- 0 V, the reference voltage for communication should be included in the cabling. With two-way communication use two pairs; one pair for communication and one pair for 0 V.
- The shield must be grounded at one end. The other end is usually grounded, but with longer distances or when there is a difference in the ground potential, the shield should be connected to the ground via 0.1 uF/250 V plastic capacitor to prevent ground current in the braided shield. A number of manufacturers recommend that the shield be grounded at each node. Various manufacturers have different systems for bus termination. The RS485 standard does not describe how the “Fail Safe” function would be carried out, just that the system should be be able to handle the error.

Depending on the recipients’ design, the bus wires may be on the same level or require pull-up or pull-down to ensure that no faulty signals are detected when the bus is in resting mode (all transmitters are disconnected).

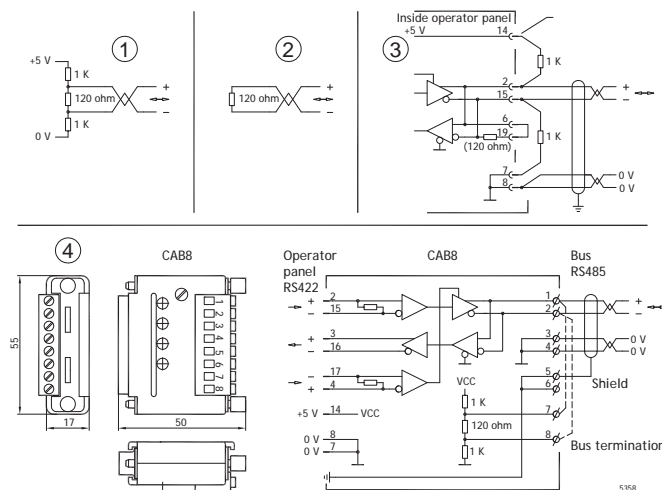

Some (older) operator panels had pull-up and pull-down resistance except for the actual bus termination at 120 ohm, similar to Westermo and Profibus. See 1 in drawing above.

Newer panels have another type of recipient, so-called built-in “Fail Safe”, where simple bus termination resistance is sufficient. See 2 in drawing above.

If other nodes on the RS485 network require pull-up and pull-down and the operator panel is at one end of the loop, one of the following procedures can be carried out:

- Connect two 1k/0.25 W resistors in the 25-pole D-sub contact. See 3 in drawing above. Set jumper pins 6-19.
- Use CAB8. It offers the option of bus termination with pull-up/-down. It is also easy to connect the bus cable via the screw terminal block. See 4 in drawing above.

Beijer

ELECTRONICS

HEAD OFFICE

SWEDEN

Beijer Electronics Products AB
Box 426
SE-201 24 Malmö, Sweden
Tel: +46 40 35 86 00
Fax: +46 40 93 23 01
info@beijerelectronics.com

SUBSIDIARIES

GERMANY

Elektronik-Systeme Lauer GmbH & Co. KG
Kelterstraße 59
72669 Unterensingen, GERMANY
Tel: +49 7022 9660 0
Fax: +49 7022 9660 103
info@lauer-hmi.com

TAIWAN

Hitech Electronics Corp.
7 & 8 F, No. 108 Min-Quan Road
Shin-Tien, Taipei Shien, TAIWAN, R.O.C. 231
Tel: +886-2-2218-3600
Fax: +886-2-2218-9547
info.hmi@hitech-lcd.com.tw

USA

Beijer Electronics Inc.
939 N. Plum Grove Road, Suite F
Schaumburg, IL 601 73, USA
Tel: +1 847 619 6068
Fax: +1 847 619 6674
info.usa@beijerelectronics.com

CHINA

Beijer Electronics Co. Ltd
Room 201, Building B, No. 1618,
Yishan Road, Shanghai 201103, CHINA
Tel: +86 21 6145 0400
Fax: +86 21 6145 0499
info@beijerelectronics.cn