

## Ratings

Power supply voltage	K8DT-AS□□D: 24 VAC 50/60 Hz, 24 VDC K8DT-AS□□A: 100 to 240 VAC 50/60 Hz
Power consumption	24 VAC/DC: 1.8 VA/1 W max. 100 to 240 VAC: 2.5 VA max.
Rated insulation voltage	600 VAC
Operating value setting range (SV)	10% to 100% of the maximum value of the setting range K8DT-AS1: 2 to 20 mA AC/DC 10 to 100 mA AC/DC 50 to 500 mA AC/DC K8DT-AS2: 0.1 to 1 A AC/DC (Compatible with commercially available CTs.) 0.5 to 5 A AC/DC (Compatible with commercially available CTs.) K8DT-AS3: When used with the OMRON CT (K8AC-CT200L). 10 to 100 A AC 20 to 200 A AC
Operating value	100% operation at set value
Reset value setting range (HYS)	5% to 50% of operating value
Reset method	Manual reset/automatic reset (switchable) <b>Note:</b> Manual reset: Turn OFF power supply for 1 s or longer.
Operating time setting range (T)	0.1 to 30 s
Startup lock time setting range (LOCK)	0 to 30 s (The startup lock timer starts when the input has reached approximately 30% or more of the set value.) <b>Note:</b> Enabled only for overcurrent operation.
LED Indicators	Power (PWR): Green, Output (OUT): Yellow, Alarm outputs (ALM): Red
Input impedance	Refer to <i>Input Range</i> on page 2.
Output form	Relay Output: SPDT contact Transistor Output: 1 Switchable between normally open and normally closed with a DIP switch setting.
Output relay ratings	Rated load: 250 VAC 5 A or 30 VDC 5 A (resistive load), 250 VAC 1 A (inductive load), 48 VDC 0.2 A (inductive load) Minimum load: 5 VDC, 10 mA (reference values) Mechanical life: 10 million operations min. Electrical life: 5 A at 250 VAC or 30 VDC: 50,000 operations 3 A at 250 VAC or 30 VDC: 100,000 operations
Transistor output ratings	Rated voltage: 24 VDC (maximum voltage: 26.4 VDC) Maximum current: 50 mA DC
Ambient operating temperature	-20 to 60°C (with no condensation or icing)
Storage temperature	-25 to 65°C (with no condensation or icing)
Ambient operating humidity	25% to 85% RH (with no condensation)
Storage humidity	25% to 85% RH (with no condensation)
Altitude	2,000 m max.
Applicable wires	Stranded wires, solid wires, or ferrules
Applicable wire size	0.25 to 1.5 mm <sup>2</sup> (AWG24 to AWG16)
Wire insertion force	8 N max. for AWG20 wire
Screwdriver insertion force	15 N max.
Wire stripping length	8 mm
Ferrule length	8 mm
Recommended flat-blade screwdriver	XW4Z-00B (Omron) SZF 0.4 × 2.5 (Phoenix Contact) 210-719 (Wago) SDI 0.4 × 2.5 × 75 (Weidmuller)
Current capacity	10 A (per pole)
Number of insertions	50 times
Case color	N1.5
Case material	PC, UL 94 V-0
Weight	Approx. 100 g
Mounting	Mounts to DIN Track, or screw mounting
Dimensions	17.5 × 90 × 90 mm (W×H×D)

## Specifications

Allowable operating voltage range	85% to 110% of power supply voltage	
Allowable operating frequency range	50/60 Hz ±5 Hz	
Input frequency range	K8DT-AS1 and K8DT-AS2: DC input or AC input (45 to 65 Hz) K8DT-AS3: AC input (45 to 65 Hz)	
Overload capacity	K8DT-AS1 and K8DT-AS2: Continuous input at 120% of maximum input, 1 s at 150% K8DT-AS3: Continuous input at 120%, 30 s at 200%, and 1 s at 600% with an OMRON CT (K8AC-CT200L) <b>Note:</b> Overload capacity of primary side of CT.	
Repeat error	Operating value	±0.5% full scale (at 25°C and 65% humidity, rated power supply voltage)
	Operating time	±50 ms (at 25°C and 65% humidity, rated power supply voltage)
Applicable standards	Conforming standards	EN 60947-5-1 Installation environment (pollution level 2, Overvoltage category III)
	EMC	EN 60947-5-1
	Safety standards	UL 60947-5-1 (Listing), Korean Radio Waves Act (Act 10564), CCC (GB14048.5)
Insulation resistance	20 MΩ min. Between external terminals and case Between power supply terminals and input terminals Between power supply terminals and output terminals Between input terminals and output terminals	
Dielectric strength	2,000 VAC for one minute Between external terminals and case Between power supply terminals and input terminals Between power supply terminals and output terminals Between input terminals and output terminals	
Impulse withstand voltage	6 kV (between live terminals and exposed, non-charged metal parts)	
Noise immunity	Square-wave noise of 1-μs/100-ns pulse width with 1-ns rise time 100 to 240 VAC: 1,500 V power supply terminal common/normal mode 24 VAC: 1,500 V power supply terminal common/normal mode 24 VDC: 480 V power supply terminal common	
Vibration resistance	Frequency 10 to 55 Hz, 0.35-mm single amplitude 10 sweeps of 5 min each in X, Y, and Z directions	
Shock resistance	100 m/s <sup>2</sup> , 3 times each in 6 directions along 3 axes	
Degree of protection	Terminals: IP20	

# K8DT-AS

## Connections

### Terminal Diagram

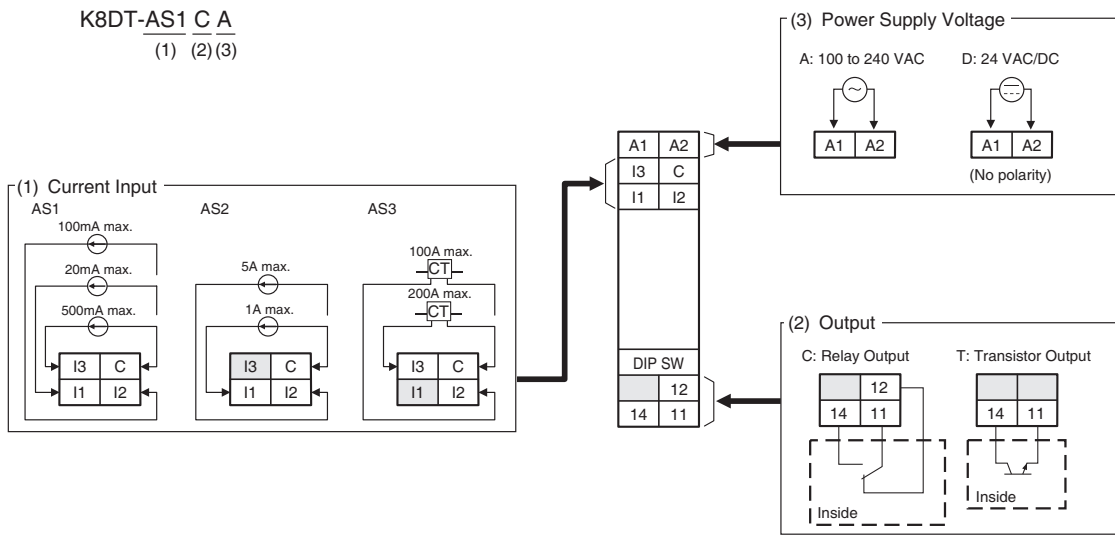

- Note:**
1. Do not connect anything to terminals that are shaded in gray.
  2. There is no polarity for the DC power supply input.
  3. For the current input, you can input only from the C terminal and one other terminal.
  4. Refer to *Setting Ranges and Wiring Connections* on the I1, I2, and I3 current input terminals.
  5. The K8DT-AS3 is designed to be used in combination with the OMRON K8AC-CT200L Current Transformer (CT).

### Wiring Example

#### Directly Inputting a Current

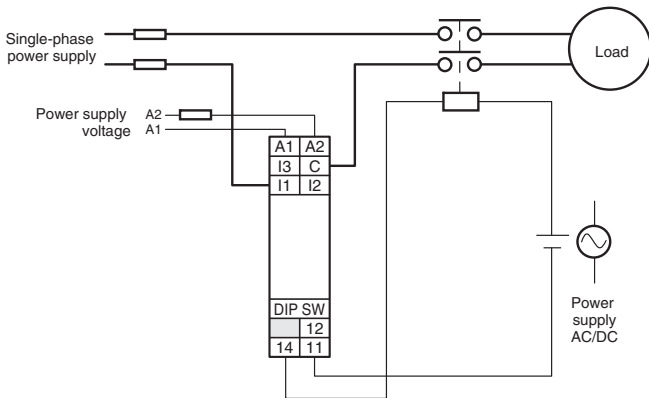

#### Using a CT

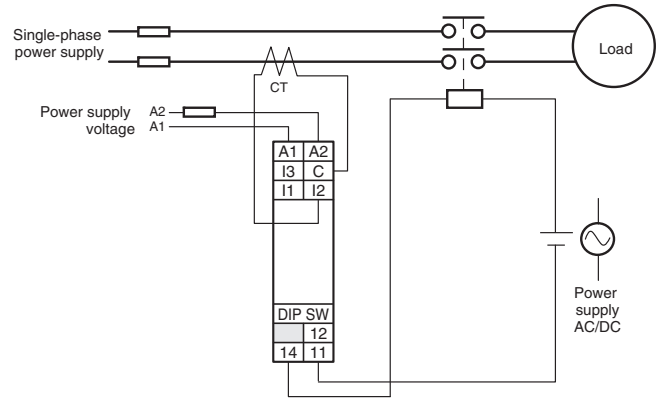

#### Transistor Output

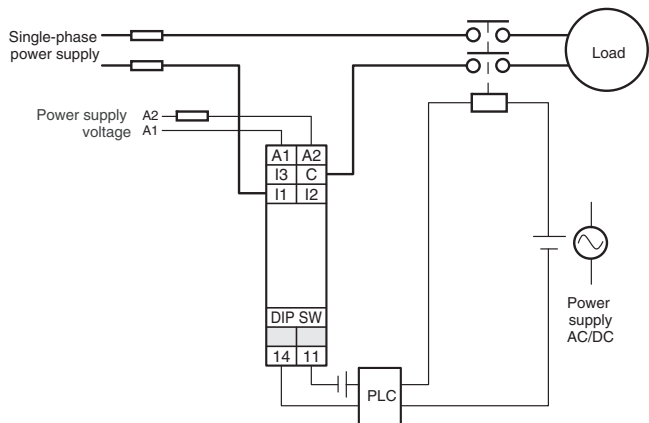

- Note:** Use copper wires with a rating of 75°C or an equivalent rating.