

Si115x Data Sheet

Proximity/Ambient Light Sensor IC with I²C Interface

The Si115x-AB00/AB09/AB9x is an ambient light sensor, proximity, and gesture detector with I²C digital interface and programmable-event interrupt output.

This touchless sensor IC includes dual 23-bit analog-to-digital converters, an integrated high-sensitivity array of visible and infrared photodiodes, a digital signal processor, and up to three integrated LED drivers with programmable drive levels. The Si115x offers excellent performance under a wide dynamic range and a variety of light sources, including direct sunlight. The Si115x can also work under dark glass covers. The photodiode response and associated digital conversion circuitry provide excellent immunity to artificial light flicker noise and natural light flutter noise. With two or more LEDs, the Si115x is capable of supporting multiple-axis proximity motion detection. The Si115x is provided in a 10-lead 2x2 mm DFN package or in a 10-lead 2.9x4.9 mm LGA module with integrated LED, and is capable of operation from 1.62 to 3.6 V over the -40 to +85 °C temperature range.

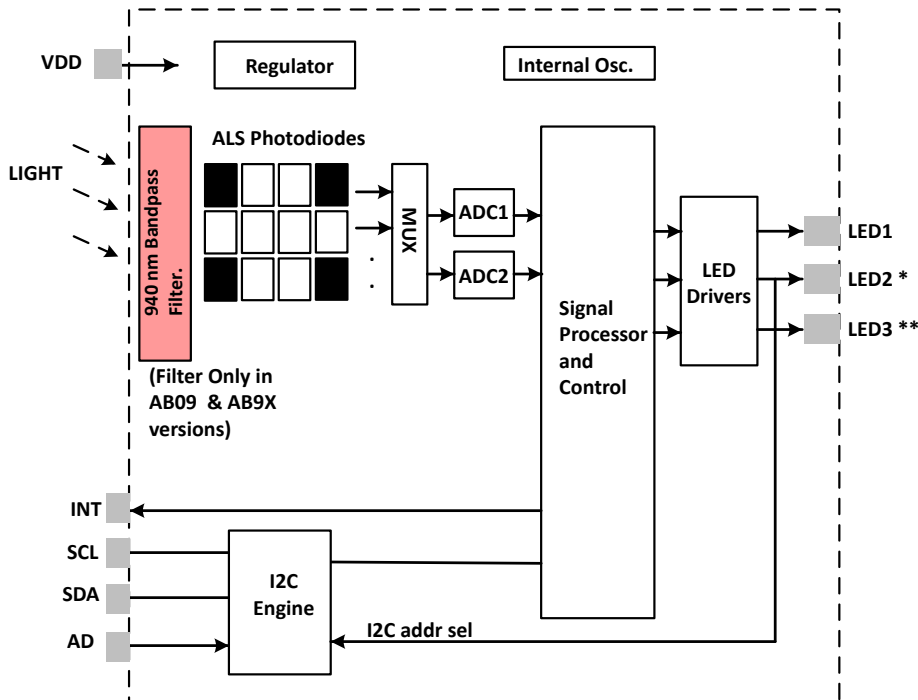

* Pull up to VDD with 47 kOhm resistor to select primary I2C address (0x53), or down to GND for alt I2C address 0x52. LED2 driving capabilities only available on Si1152 and Si1153.

** Pull up to VDD with 47 kOhm resistor. LED3 driving capabilities only available on Si1153.

KEY FEATURES

- Proximity detector
 - From under 1 cm, to 50 cm without additional lensing.
 - From under 1 cm, to 200 cm with additional lensing (e.g., 5 mm hemispherical lens as in our EVB).
 - Up to three independent LED drivers.
 - 30 current settings from 5.6 mA to 360 mA for each LED driver.
 - Operates in direct sunlight with optional on-die 940 nm passband filter.
 - On die 940 bandpass filter that rejects unwanted visible light and IR from daylight and other sources (Si115x-AB09/AB9X).
- Ambient light sensor
 - <100 mlx resolution possible, allowing operation under dark glass.
 - Up to 128 klx dynamic range possible across two ADC range settings.
- Industry's lowest power consumption
 - 1.62 to 3.6 V supply voltage.
 - 9 µA average current (LED pulsed 24.4 µs every 800 ms at 180 mA plus 3 µA Si115x supply).
 - <500 nA standby current.
 - 24.4 µs LED "on" time keeps total power consumption duty cycle low without compromising performance or noise community.
 - Internal and external wake support.
 - Built-in voltage supply monitor and power-on reset controller.

APPLICATIONS

- Wearables
- Handsets
- Display backlighting control
- Consumer electronics

Table of Contents

1. Feature List	4
2. Ordering Guide	5
3. Functional Description	6
3.1 Ambient Light Sensing	8
3.2 Proximity Sensing	8
3.3 Power Consumption	10
3.4 Host Interface	11
4. Operational Modes	13
4.1 Off Mode	13
4.2 Initialization Mode	13
4.3 Standby Mode	13
4.4 Forced Conversion Mode	13
4.5 Automated Operation Mode	13
5. User to Sensor Communication	14
5.1 Basic I ² C Operation	14
5.2 Relationship Between I ² C Registers and Parameter Table	15
5.3 I ² C Command Register Operation	17
5.3.1 Accessing the Parameter Table (PARAM_QUERY & PARAM_SET Commands)	19
5.3.2 Sensor Operation Initiation Commands	19
5.3.3 RESET_CMD_CTR Command	19
5.3.4 RESET Command	19
5.4 I ² C Register Summary	20
5.4.1 PART_ID	20
5.4.2 HW_ID	21
5.4.3 REV_ID	21
5.4.4 INFO0	21
5.4.5 INFO1	21
5.4.6 HOSTIN0	22
5.4.7 COMMAND	22
5.4.8 IRQENABLE	22
5.4.9 RESPONSE1	22
5.4.10 RESPONSE0	23
5.4.11 IRQ_STATUS	24
5.4.12 HOSTOUTx	24
6. Measurement: Principle of Operation	25
6.1 Output Field Utilization	25
6.2 Autonomous and Forced Modes	27
6.3 Burst Mode	29