

Contents

	Page		Page
General		IXYS	
Contents	III	Diodes	
QA and Environmental Management Systems	IV	Gallium Arsenide & Silicon Carbide Schottky Diodes	97
Product Offering	V	Schottky & Schottky Gen ² Diodes	98
Alphanumeric Index	VI	HiPerDyn™ FREDs (Dual Ultrafast)	101
Nomenclature	XVII	Sonic-FRDs™	102
Symbols and Terms	XX	Fast Diodes (HiPerFRED, HiPerFRED ² & FRED)	102
Patents and Intellectual Property	XXII	FRED & HiPerFRED Modules	106
		Rectifier & Avalanche Types	107
MICRONIX			
Analog Mixed Signal ASIC Capabilities	1	Thyristors	
IXYS RF		Phase Control Types	110
DE Linear and Switch Mode Series	17	Rectifier Diode Modules	111
RF MOSFET Gate Driver	18	Thyristor/Diode Modules	113
Switch Mode MOSFETs (DE & F Series)	19	Thyristor Modules	115
		Accessories & Design Information	119
MwT			
Hybrid Microwave Modules	20	Rectifier Bridges	
Standard Amplifier	21	1~/3~ PFC Modules	120
GaAs FETs & PHEMTs	22	MOS/IGBT AC Switches	121
Wireless Amplifiers (MPS, ULA and WPS WiMax)	24	3~ Rectifier Bridges with Brake Unit	122
		Rectifier Bridges with Fast Diodes	123
CLARE		1~ Rectifier Bridges	124
Optically Isolated Solid State Relays	26	1~/3~ High Voltage Rectifiers	128
Optically Isolated AC-Power Switches	31	High Voltage Rectifiers	128
Power Solid State Relays	32	3~ Rectifier Bridges	129
Linear Optocouplers and Isolation Amplifiers	34	AC Controller	134
Optically Isolated Error Amplifiers	35	Braking Rectifier Assemblies	136
Single and Dual Optocouplers	36		
OptoMOS & Telecom Multifunction Products	37	Protection Devices	
xDSL/ISDN DC Termination ICs	39	Breakover Diodes (BOD)	136
Line Card Access Switches (LCAS)	40		
LITELINK™ Silicon DAA	42	Integrated Circuits (IC)	
Phone Line Monitor	44	MOSFET & IGBT Drivers	137
FETs, N-Channel Depletion Mode	45	Half Bridge and 3~ Drivers	139
Data Access Arrangement (DAA) Modules	46	Evaluation Boards	142
Embedded Modem Modules (EMM)	47	High Voltage Current Regulators	143
Tone Signaling Products	48	Various Types	144
High Voltage Analog Switches and Display Drivers	50		
Optically Isolated Gate Drivers	51	Power Semiconductor Chips	147
Solar Cell Products	52	IXOLAR™ High Efficiency Solar Cells & Solar Bits	148
Application Notes	53	Direct Copper Bonded Ceramic Substrates	150
IXYS			
ISOPLUS™ family	54	WESTCODE	
IGBTs		Application Notes & Technical Information	151
CBI Modules	63	Rectifier Diodes	152
Six-Packs	66	Fast Recovery Diodes	157
Full Bridge Modules	68	Phase Control Thyristors	163
Dual & Single Switches	69	Medium Voltage Thyristors	168
Discrete NPT and NPT ³ IGBTs	73	Fast Switching Thyristors	170
S (SCSOA) & G Series	74	GTOs	178
Polar & High Speed Series	76	Pulse Thyristors	179
High Voltage Types (≥1700 V)	78	Press Pack IGBTs	180
BiMOSFET & RIGBTs	80	High Voltage IGBT Gate Drive Units	181
		Power Semiconductor Assemblies	182
Power MOSFETs			
PolarHT™ & PolarHV™ Series (Fast Body Diode)	81	Outline Drawings	
Q2-Class HiPerFETs™	88	IXYS RF	188
Standard N-channel & Depletion-Mode Types	89	MwT	189
P-channel & Linear Types	90	IXYS	193
CoolMOS™ Types	91	Westcode	213
Trench Gate Power Types	91		
MOSFET Modules	94	Worldwide Sales Representatives	225
Trench MOSFET Modules	95		

QA and Environmental Management Systems

Certificates



ISO 9001:2000



ISO/TS 16949:2002
(includes ISO 9001:2000)

ISO 14001
(Environmental)



ISO 9001:2000



ISO 9001:2000



BS EN 9001:2000



ISO 9001:2000



IXYS Product Portfolio

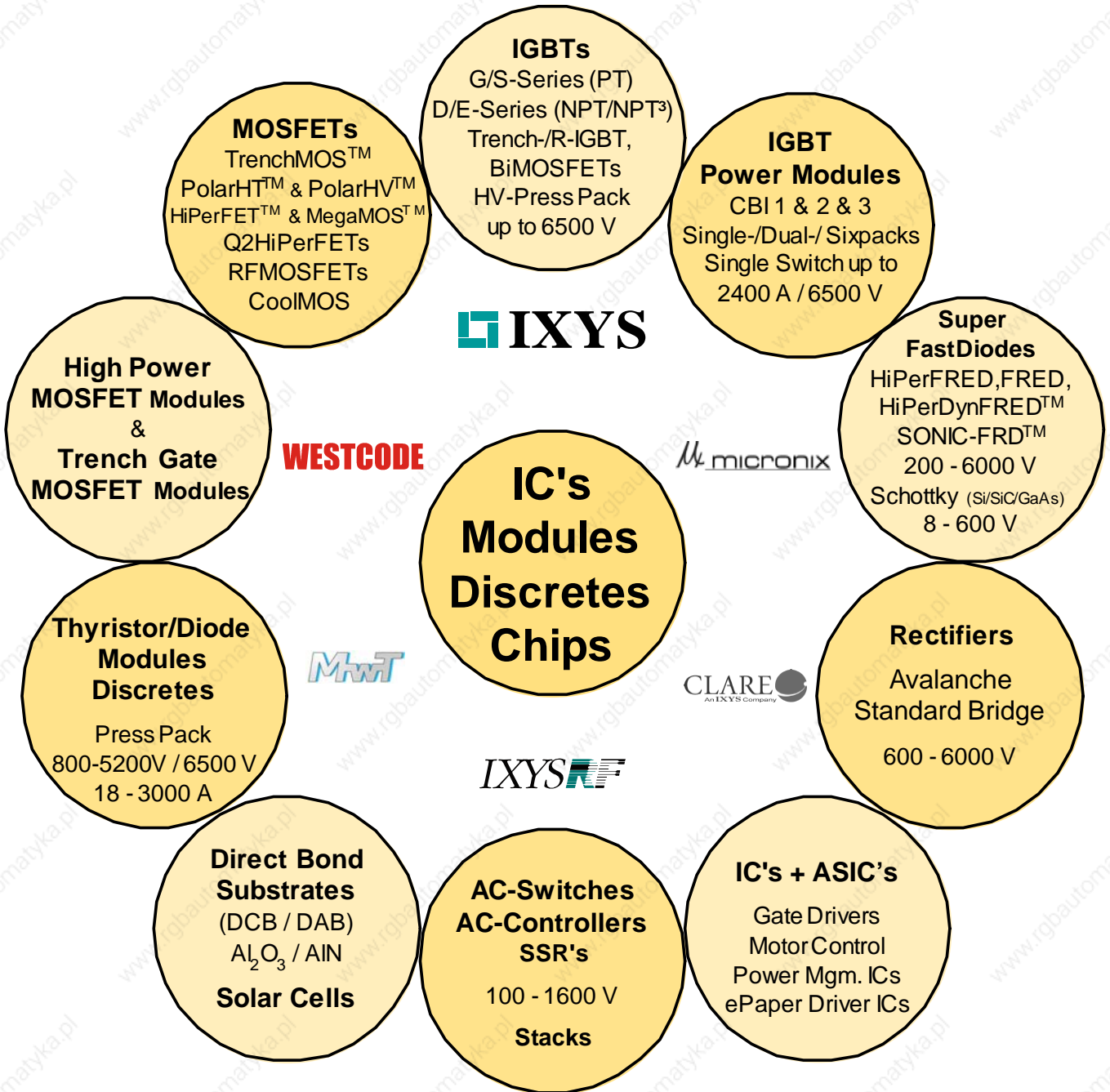

Alphanumeric Index

► new

DSEI 2X 31-04C	105	DSEP 30-12A	103	DSSK 18-0025B	98	FBS 10-06SC	59, 97, 123	HTZ 250G39K	128
DSEI 2X 31-06C	105	DSEP 30-12AR	56, 103	DSSK 18-0025BS	98	► FBS 10-12SC	59	HTZ 250G44K	128
DSEI 2X 31-06P	105	DSEP 30-12CR	56, 101	DSSK 20-0045A	98	FBS 16-06SC	59, 97, 123	HTZ 260G14K	128
DSEI 2X 31-10B	105	► DSEP 40-03AS	102	DSSK 20-0045AM	98	FCC 21-12io	59, 11	HTZ 260G16K	128
DSEI 2X 31-10P	105	DSEP 60-03A	102	DSSK 20-0045B	98	FDM 21-05QC	58, 94	HTZ 260G19K	128
DSEI 2X 31-12B	105	DSEP 60-04A	102	DSSK 20-015A	99	► FDM 25-06KC5	91, 94	HTZ 260G22K	128
DSEI 2X 31-12P	105	DSEP 60-06A	102	DSSK 28-0045A	98	► FDM 25-06KC5SiC	91, 94	HTZ 270H40K	128
DSEI 2X 61-02A	105	DSEP 60-06AT	102	DSSK 28-0045B	98	► FDM 40-06KC5	91, 94	HTZ 270H48K	128
DSEI 2X 61-02P	105	DSEP 60-12A	103	DSSK 28-0045BS	98	FDM 100-0045SP	58, 95	HTZ 270H56K	128
DSEI 2X 61-04C	105	DSEP 60-12AR	56, 103	DSSK 28-006B	98	FID 35-06C	58, 69, 73, 120	HTZ 270H64K	128
DSEI 2X 61-06C	105	DSI 17-08A	107	DSSK 28-006BS	98	FID 36-06D	58, 69, 73, 120	HTZ 280H20K	128
DSEI 2X 61-06P	105	DSI 17-12A	107	DSSK 28-01A	99	FID 60-06D	58, 69, 73, 120	HTZ 280H24K	128
DSEI 2X 61-10B	105	DSI 2x55-12A	108	DSSK 28-01AS	99	FII 30-06D	58, 69, 73	HTZ 280H28K	128
DSEI 2X 61-10P	105	DSI 2x55-16A	108	DSSK 30-0045A	98	FII 30-12E	58, 69, 73	HTZ 280H32K	128
DSEI 2X 61-12B	105	DSI 30-08A	107	DSSK 30-0045B	98	FII 40-06D	58, 69, 73	HVL 900-12io1	135
DSEI 2X 61-12P	105	DSI 30-08AC	107	DSSK 30-018A	99	FII 50-12E	58, 69, 73	HVL 900-14io1	135
DSEI 2X101-06A	105	DSI 30-08AS	107	DSSK 30-01A	99	FIO 50-12BD	58, 73, 121	HVL 900-16io1	135
DSEI 2X101-06P	105	DSI 30-12A	107	DSSK 38-0025B	98	FMD 21-05QC	58, 94, 120	HVL 900-18io1	135
DSEI 2X101-12A	105	DSI 30-12AC	107	DSSK 38-0025BS	98	► FMD 25-06KC5	91, 94, 120		
DSEI 2X101-12P	105	DSI 30-12AS	107	DSSK 40-0015B	98	► FMD 25-06KC5SiC	91, 94, 120		
DSEI 2X121-02A	105	DSI 30-16A	107	DSSK 40-006B	98	FMD 40-06KC	58, 91, 94, 120		
DSEI 2X121-02P	105	DSI 30-16AS	107	DSSK 40-008B	99	► FMD 40-06KC5	91, 94, 120		
DSEI 2X161-02P	105	DSI 35-08A	108	DSSK 48-0025B	98	FMD 80-0045PS	58		
DSEI 2X161-06P	105	DSI 35-12A	108	DSSK 48-003B	98	FMD 80-0045SP	95		
DSEI 2X161-12P	105	DSI 45-08A	108	DSSK 48-003BS	98	FMK 75-01F	58, 94, 121		
DSEI 30-06A	104	DSI 45-12A	108	DSSK 50-0025B	98	FMM 65-015P	58, 95		
DSEI 30-10A	104	DSI 45-16A	108	DSSK 50-015A	99	FMM 75-01F	58, 94		
DSEI 30-10AR	56, 104	DSI 45-16AR	56, 108	DSSK 50-01A	99	FMM 150-0075P	58, 95		
DSEI 30-12A	104	DSI 75-08B	108	DSSK 60-0045A	98	FMM 200-0075P	95		
DSEI 36-06AS	104	DSI 75-12B	108	DSSK 60-0045B	98	FMM 300-0055P	58, 95		
DSEI 60-02A	104	DSIK 45-16AR	56, 108	DSSK 60-015 AR	56, 99	FSS 100-008A	59, 99		
DSEI 60-06A	104	DSP 8-08A	107	DSSK 60-015A	99	FUE 30-12N1	59, 123		
DSEI 60-06AT	104	DSP 8-08AS	107	► DSSK 60-02A	99	FUO 22-12N	59, 129		
DSEI 60-10A	104	DSP 8-08S	107	► DSSK 60-02AR	56, 99	FUO 22-16N	59, 129		
DSEI 60-12A	104	DSP 8-12A	107	DSSK 70-0015B	98	FUO 50-16N	59, 129		
DSEI 120-06A	104	DSP 8-12AC	55, 107	DSSK 70-003B	98	FUS 45-0045B	59, 98		
DSEI 120-12A	104	DSP 8-12AS	107	DSSK 70-008A	99				
DSEI 120-12A	104	DSP 8-12S	107	► DSSK 70-008AR	56, 99				
DSEK 60-02A	104	DSP 25-12A	107	DSSK 80-0008D	98	G			
DSEK 60-02AR	56, 104	DSP 25-12AT	107	DSSK 80-0025B	98	GBO 25-12NO1	124		
DSEK 60-06A	104	DSP 25-16A	107	DSSK 80-003B	98	GBO 25-16NO1	124		
DSEK 60-12A	104	DSP 25-16AR	56, 107	DSSK 80-0045B	98	GDBD 4410	65		
DSEP 6-06AS	102	DSP 25-16AT	107	DSSK 80-006B	98	GWM 70-01P2	60, 95		
DSEP 8-02A	102	DSP 45-12A	107	► DSSK 80-006B	98	► GWM 95-01X1	60, 95		
DSEP 8-03A	102	DSP 45-16A	107	► DSSK 80-06BR	56, 98	► GWM 100-0085X1	60, 95		
DSEP 8-03AS	102	DSP 45-16AR	56, 107	► DSSS 30-01AR	56, 99	GWM 120-0075P3	60, 95		
DSEP 8-06A	102	DSS 6-0025BS	98	► DSSS 35-008AR	56, 99	GWM 160-0055P3	60, 95		
DSEP 8-06B	102	DSS 6-0045AS	98			GWM 220-004P3	60, 95		
DSEP 8-12A	103	DSS 6-015AS	99	E					
DSEP 9-06CR	56, 101	DSS 10-0045A	98	EV6R 11S3	142				
DSEP 12-12A	103	DSS 10-0045B	98	EV6R 11S7	142	HTZ 110A16K	128		
► DSEP 12-12B	103	DSS 10-006A	98	EVBD 4400	142	HTZ 110A19K	128		
DSEP 15-03A	102	DSS 10-01A	99	EVDD 404	142	HTZ 110A22K	128		
DSEP 15-06A	102	DSS 10-01AS	99	EVDD 414	142	HTZ 110A25K	128		
DSEP 15-06B	102	DSS 16-0045A	98	EVDD 415	142	HTZ 120A32K	128		
DSEP 15-12CR	56, 101	DSS 16-0045AS	98	EVDD 430CI	142	HTZ 120A38K	128		
DSEP 29-03A	102	DSS 16-0045B	98	EVDD 430MCI	142	HTZ 120A44K	128		
DSEP 29-06A	102	DSS 16-01A	99	EVDD 430MYI	142	HTZ 120A51K	128		
DSEP 29-06AS	102	DSS 16-01AS	99	EVDD 430YI	142	HTZ 130B24K	128		
DSEP 29-06B	102	DSS 17-06CR	56	EVDI 402	142	HTZ 130B28K	128		
DSEP 29-12A	103	DSS 17-06CR	101	EVDI 404	142	HTZ 130B33K	128		
DSEP 2x 25-12C	101	DSS 20-0015B	98	EVDI 409	142	HTZ 130B38K	128		
DSEP 2x 31-03A	103	DSS 20-01AC	99	EVDI 414	142	HTZ 150C6K	128		
DSEP 2x 31-04A	103	DSS 25-0025B	98	EVDI 430CI	142	HTZ 150C7K	128		
DSEP 2x 31-06A	103	DSS 25-0045A	98	EVDI 430MCI	142	HTZ 150C8K	128		
DSEP 2x 31-06B	103	DSS 2X 41-01A	99	EVDI 430MYI	142	HTZ 150C9K	128		
DSEP 2x 31-12A	103	DSS 2X 61-0045A	98	EVDI 430YI	142	HTZ 160C12K	128		
DSEP 2x 35-06C	101	DSS 2X 61-01A	99	EVDN 402	142	HTZ 160C14K	128		
DSEP 2x 61-03A	103	DSS 2X 81-0045B	98	EVDN 404	142	HTZ 160C17K	128		
DSEP 2x 61-06A	103	DSS 2x101-015A	99	EVDN 409	142	HTZ 160C19K	128		
DSEP 2x 61-12A	103	► DSS 2x101-02A	99	EVND 414	142	HTZ 160C19K	128		
DSEP 2x 91-03A	103	DSS 2X111-008A	99	EVND 414	142	HTZ 170C2.4K	128		
DSEP 2x 91-06A	103	DSS 2x121-0045B	98	EVND 430CI	142	HTZ 170C2.8K	128		
DSEP 2x101-04A	103	DSS 2X160-0045A	98	EVND 430MCI	142	HTZ 170C2K	128		
DSEP 30-03A	102	DSS 2X160-01A	99	EVND 430MYI	142	HTZ 180D22K	128		
► DSEP 30-03AS	102	► DSS 2X200-0008D	98	EVND 430YI	142	HTZ 180D26K	128		
DSEP 30-04A	102	DSS 40-0008D	98	EVDS 430SI	142	HTZ 180D30K	128		
DSEP 30-06A	102	DSS 60-0045B	98	EVIC 420A	142	HTZ 180D35K	128		
DSEP 30-06B	102	DSSK 10-018A	99	EVIC 420B	142	HTZ 240F10K	128		
DSEP 30-06BR	56, 102	DSSK 16-01A	99			HTZ 240F12K	128		
DSEP 30-06CR	56, 101	DSSK 16-01AS	99	F		HTZ 240F14K	128		
				FBE 22-06N1	59, 123	HTZ 240F16K	128		
				FBO 16-12N	59, 120, 124	HTZ 250G28K	128		
				FBO 40-12N	59, 120, 124	HTZ 250G33K	128		

Alphanumeric Index

➤ new

IXBOD 1 - 40R	136	IXDI 414 YI	138	➤ IXFC 96N15P	55, 84	➤ IXFN 60N80P	87	➤ IXFV 16N80PS	87
IXBOD 1 - 42R	136	IXDI 430CI	138	➤ IXFC 110N10P	55, 84	➤ IXFN 64N50P	86	➤ IXFV 18N60P	86
IXBP 5N160G	80	IXDI 430MCI	138	IXFF 24N100	58	➤ IXFN 64N50PD2	86, 120	➤ IXFV 18N60PS	86
IXBT 6N170	80	IXDI 430MYI	138	➤ IXFF 80N50Q2	88	➤ IXFN 64N60P	86	➤ IXFV 20N80P	87
IXBT 10N170	80	IXDI 430YI	138	IXFH 4N100Q	88	IXFN 66N50Q2	88	➤ IXFV 20N80PS	87
IXBT 16N170	80	IXDN 402 PI	137	➤ IXFH 10N80P	87	IXFN 70N60Q2	88	➤ IXFV 22N50P	85
IXBT 16N170A	80	IXDN 402 SI	137	➤ IXFH 12N80P	87	IXFN 72N55Q2	88	➤ IXFV 22N50PS	85
IXBT 42N170A	80	IXDN 402SI-16	137	IXFH 14N100Q2	86	➤ IXFN 80N50P	86	➤ IXFV 22N60P	86
➤ IXC 611P1	140	IXDN 402SIA	137	➤ IXFH 14N60P	86	IXFN 80N50Q2	88	➤ IXFV 22N60PS	86
➤ IXC 611S1	140	IXDN 402SIA-16	137	➤ IXFH 14N80P	87	➤ IXFN 82N60P	86	➤ IXFV 26N50P	85
IXCP 02M45	143	IXDN 404 PI	137	➤ IXFH 16N50P	85	➤ IXFN 100N50P	86	➤ IXFV 26N50PS	85
IXCP 10M45	143	IXDN 404 SI	137	➤ IXFH 16N80P	87	➤ IXFN 102N30P	85	➤ IXFV 26N60P	86
IXCP 10M45S	143	IXDN 404 SI-16	137	➤ IXFH 18N60P	86	➤ IXFN 140N20P	85	➤ IXFV 26N60PS	86
IXCP 10M90S	143	IXDN 404SIA	137	➤ IXFH 20N80P	87	➤ IXFN 140N30P	85	➤ IXFV 30N50P	85
IXCP 20M45	143	IXDN 404SIA-16	137	➤ IXFH 22N50P	85	IXFN 180N07	88	➤ IXFV 30N50PS	85
IXCP 40M45	143	IXDN 409 CI	138	➤ IXFH 22N60P	86	IXFN 180N10	88	➤ IXFV 30N60P	86
IXCP 50M45	143	IXDN 409 PI	138	➤ IXFH 24N80P	87	➤ IXFN 180N15P	84	➤ IXFV 30N60PS	86
IXCP 60M45	143	IXDN 409 SI	138	➤ IXFH 26N50P	85	➤ IXFN 200N10P	84	➤ IXFV 36N50P	85
IXCY 02M45	143	IXDN 409 YI	138	➤ IXFH 26N60P	86	IXFN 280N085	88	➤ IXFV 36N50PS	85
IXCY 10M45	143	IXDN 414 CI	138	➤ IXFH 30N50P	85	IXFN 340N07	88	➤ IXFV 52N30P	85
IXCY 10M45S	143	IXDN 414 PI	138	➤ IXFH 30N60P	86	IXFP 3N120	88	➤ IXFV 52N30PS	85
IXCY 10M90S	143	IXDN 414SI	138	➤ IXFH 36N50P	85	➤ IXFP 3N50PM	85	➤ IXFV 74N20P	84
IXCY 20M45	143	IXDN 414 YI	138	➤ IXFH 36N60P	86	IXFP 4N100Q	88	➤ IXFV 74N20PS	84
IXCY 30M45	143	IXDN 430CI	138	IXFH 40N50Q2	88	➤ IXFP 5N50PM	85	➤ IXFV 96N15P	84
IXCY 50M45	143	IXDN 430MCI	138	➤ IXFH 44N50P	85	➤ IXFP 7N80P	87	➤ IXFV 96N15PS	84
IXCY 60M45	143	IXDN 430MYI	138	➤ IXFH 52N30P	85	➤ IXFP 7N80PM	87	➤ IXFV 96N20P	84
➤ IXD 611P1	140	IXDN 430YI	138	➤ IXFH 69N30P	85	➤ IXFP 8N50PM	85	➤ IXFV 110N10P	84
➤ IXD 611P7	140	IXDN 55N120D1	73	➤ IXFH 74N20P	84	➤ IXFP 10N60P	86	➤ IXFV 110N10PS	84
➤ IXD 611S1	140	IXDN 75N120	73	➤ IXFH 88N30P	85	➤ IXFP 10N80P	87	IXFX 24N100	88
➤ IXD 611S7	140	IXDP 20N60B	73	➤ IXFH 96N15P	84	➤ IXFP 12N50P	85	➤ IXFX 30N100Q2	88
IXDA 20N120AS	73	IXDP 20N60BD1	73	➤ IXFH 96N20P	84	➤ IXFP 12N50PM	85	➤ IXFX 32N80P	87
IXDD 404 PI	137	IXDP 35N60B	73	➤ IXFH 100N25P	85	➤ IXFP 14N60P	86	➤ IXFX 38N80Q2	88
IXDD 404 SI	137	IXDP 610PI	144	➤ IXFH 110N10P	84	➤ IXFP 16N50P	85	➤ IXFX 44N80P	87
IXDD 404 SI-16	137	IXDP 630PI	144	➤ IXFH 120N15P	84	➤ IXFQ 10N80P	87	➤ IXFX 48N60P	86
IXDD 404SIA	137	IXDP 631PI	144	➤ IXFH 120N20P	85	➤ IXFQ 12N80P	87	IXFX 52N60Q2	88
IXDD 404SIA-16	137	IXDR 30N120	73	➤ IXFH 140N10P	84	➤ IXFQ 14N80P	87	IXFX 60N55Q2	88
IXDD 409CI	138	IXDR 30N120D1	73	➤ IXFH 150N15P	84	IXFR 4N100Q	56, 88	➤ IXFX 64N50P	86
IXDD 409PI	138	IXDR 35N60BD1	73	➤ IXFH 170N10P	84	➤ IXFR 14N100Q2	56, 88	➤ IXFX 64N60P	86
IXDD 409SI	138	IXDS 430SI	138	➤ IXFI 7N80P	87	➤ IXFR 20N80P	56, 87	IXFX 66N50Q2	88
IXDD 409YI	138	➤ IXE 611P1	140	IXFK 24N100	88	IXFR 21N100Q	56	➤ IXFX 80N50P	86
IXDD 414 CI	138	➤ IXE 611S1	140	➤ IXFK 24N80P	87	IXFR 24N100	56	➤ IXFX 120N25P	85
IXDD 414 PI	138	IXEH 25N120	73	➤ IXFK 30N100Q2	88	➤ IXFR 24N80P	56, 87	➤ IXFX 140N30P	85
IXDD 414SI	138	IXEH 25N120D1	73	➤ IXFK 32N80P	87	IXFR 24N90Q	56	IXFX 180N07	88
IXDD 414 YI	138	IXEH 40N120	73	➤ IXFK 36N60P	86	➤ IXFR 30N60P	56, 86	IXFX 180N10	88
IXDD 430CI	138	IXEH 40N120D1	73	➤ IXFK 38N80Q2	88	➤ IXFR 32N80P	56, 87	➤ IXFX 180N15P	84
IXDD 430MCI	138	➤ IXEL 40N400	56, 79	➤ IXFK 44N50P	85	➤ IXFR 36N50P	56, 85	➤ IXFX 200N10P	84
IXDD 430MYI	138	IXEN 60N120	73	➤ IXFK 44N80P	87	➤ IXFR 36N60P	56, 86	➤ IXG 611P1	140
IXDD 430YI	138	IXEN 60N120D1	73	➤ IXFK 48N60P	86	➤ IXFR 38N80Q2	56, 88	➤ IXG 611S1	140
IXDF 402 PI	137	IXER 35N120D1	73	IXFK 52N60Q2	88	IXFR 40N50Q2	56, 88	IXGA 7N60B	76
IXDF 402 SI	137	IXER 60N120	73	IXFK 60N55Q2	88	➤ IXFR 44N50P	56, 86	IXGA 7N60C	76
IXDF 402SI-16	137	➤ IXF 611P1	140	➤ IXFK 64N50P	86	➤ IXFR 44N80P	56, 87	IXGA 8N100	75
IXDF 402SIA	137	➤ IXF 611S1	140	➤ IXFK 64N60P	86	➤ IXFR 48N60P	56, 86	➤ IXGA 14N120B	76
IXDF 402SIA-16	137	IXFA 3N120	88	IXFK 66N50Q2	88	➤ IXFR 64N50P	56, 86	IXGA 15N120B	76
IXDF 404 PI	137	IXFA 4N100Q	88	➤ IXFK 80N50P	86	➤ IXFR 64N60P	56, 86	➤ IXGA 15N120B2	76
IXDF 404 SI	137	➤ IXFA 7N80P	87	➤ IXFK 88N30P	85	IXFR 66N50Q2	56, 88	IXGA 16N60B2	76
IXDF 404 SI-16	137	➤ IXFA 10N60P	86	➤ IXFK 102N30P	85	➤ IXFR 80N50P	56, 86	IXGA 16N60B2D1	77
IXDF 404SIA	137	➤ IXFA 10N80P	87	➤ IXFK 120N20P	85	➤ IXFR 102N30P	56, 85	IXGA 16N60C2	77
IXDF 404SIA-16	137	➤ IXFA 12N50P	85	➤ IXFK 120N25P	85	➤ IXFR 140N20P	56, 85	➤ IXGA 16N60C2D1	78
IXDH 20N120	73	➤ IXFA 14N60P	86	➤ IXFK 140N20P	85	➤ IXFR 140N30P	56, 85	IXGA 20N100	75
IXDH 20N120D1	73	➤ IXFA 16N50P	85	➤ IXFK 140N30P	85	➤ IXFR 180N15P	56, 84	IXGA 20N120	75
IXDH 30N120	73	IXFB 38N100Q2	88	➤ IXFK 150N15P	84	➤ IXFR 200N10P	56, 84	IXGC 16N60B2	55, 76
IXDH 30N120D1	73	IXFB 50N80Q2	88	➤ IXFK 170N10P	84	IXFT 4N100Q	88	IXGC 16N60B2D1	77
IXDH 35N60B	73	➤ IXFB 60N80P	87	IXFK 180N07	88	➤ IXFT 14N80P	87	IXGC 16N60C2	55, 77
IXDH 35N60BD1	73	IXFB 70N60Q2	88	IXFK 180N10	88	➤ IXFT 16N80P	87	➤ IXGC 16N60C2D1	55, 78
IXDI 402 PI	137	IXFB 72N55Q2	88	➤ IXFK 180N15P	84	➤ IXFT 20N80P	87	➤ IXGF 32N170	78
IXDI 402 SI	137	IXFB 80N50Q2	88	➤ IXFK 200N10P	84	➤ IXFT 24N80P	87	IXGH 6N170	78
IXDI 402SI-16	137	➤ IXFB 82N60P	86	IXFL 34N100	88	➤ IXFT 26N60P	86	IXGH 6N170A	79
IXDI 402SIA	137	➤ IXFB 100N50P	86	➤ IXFL 38N100Q2	56, 88	➤ IXFT 30N50P	85	IXGH 10N170	78
IXDI 402SIA-16	137	➤ IXFC 10N80P	55, 87	➤ IXFL 60N80P	87	➤ IXFT 30N60P	86	IXGH 10N170A	79
IXDI 404 PI	137	➤ IXFC 12N80P	55, 87	➤ IXFL 80N50Q2	56, 88	➤ IXFT 36N50P	85	IXGH 15N120B	76
IXDI 404 SI	137	➤ IXFC 14N60P	55, 86	➤ IXFL 82N60P	56, 86	➤ IXFT 36N60P	86	IXGH 16N170	78
IXDI 404 SI-16	137	➤ IXFC 14N80P	55, 87	➤ IXFL 100N50P	56, 86	➤ IXFT 44N50P	85	IXGH 16N170A	79
IXDI 404SIA	137	➤ IXFC 16N50P	55, 85	IXFN 230N10	88	➤ IXFT 69N30P	85	➤ IXGH 16N170AH1	79
IXDI 404SIA-16	137	➤ IXFC 16N80P	55, 87	IXFN 24N100	88	➤ IXFT 96N20P	84	IXGH 16N60B2D1	77
IXDI 409 CI	138	➤ IXFC 20N80P	55, 87	➤ IXFN 32N80P	87	➤ IXFT 120N15P	84	➤ IXGH 16N60C2D1	78
IXDI 409 PI	138	➤ IXFC 22N60P	55, 86	IXFN 34N100	88	➤ IXFT 140N10P	84	IXGH 20N100	75
IXDI 409 SI	138	➤ IXFC 26N50P	55, 85	IXFN 36N100	88	➤ IXFV 12N80P	87	IXGH 20N120	75
IXDI 409 YI	138	➤ IXFC 30N60P	55, 86	IXFN 38N100Q2	88	➤ IXFV 12N80PS	87	IXGH 20N120B	76
IXDI 414 CI	138	➤ IXFC 36N50P	55, 85	➤ IXFN 44N80P	87	➤ IXFV 14N80P	87	IXGH 24N170	78
IXDI 414 PI	138	➤ IXFC 52N30P	55, 85	➤ IXFN 48N60P	86	➤ IXFV 14N80PS	87	IXGH 24N170A	79
IXDI 414SI	138	➤ IXFC 74N20P	55, 84	IXFN 50N80Q2	88	➤ IXFV 16N80P	87	➤ IXGH 24N170AH1	79

Alphanumeric Index

► new

IXGH 25N160	78	IXGT 10N170A	79	IXSA 10N60B2D1	75	IXTA 180N10T7	93	IXTP 2N80P	84
IXGH 28N120B	76	IXGT 15N120B	76	IXSA 15N120B	74	IXTA 182N055T	92	IXTP 2R4N50P	83
IXGH 30N120B3D1	77	IXGT 16N170	78	IXSA 20N60B2D1	75	IXTA 182N055T7	92	IXTP 3N120	89
IXGH 30N60B2	76	IXGT 16N170A	79	IXSH 10N60B2D1	75	IXTA 200N075T	92	IXTP 3N50P	83
IXGH 30N60B2D1	77	IXGT 16N170AH1	79	IXSH 15N120B	74	IXTA 200N075T7	92	IXTP 3N60P	83
IXGH 30N60C2	77	IXGT 20N100	75	IXSH 15N120BD1	75	IXTA 200N085T	93	IXTP 4N60P	83
IXGH 30N60C2D1	78	IXGT 20N120	75	IXSH 24N60B2D1	75	IXTA 200N085T7	93	IXTP 4N80P	84
IXGH 32N170	78	IXGT 20N120B	76	IXSH 24N60B	74	IXTA 220N055T	92	IXTP 5N50P	83
IXGH 32N170A	79	IXGT 24N170	78	IXSH 30N60B	74	IXTA 220N055T7	92	IXTP 5N60P	83
IXGH 32N90B2	76	IXGT 24N170A	79	IXSH 30N60B2D1	75	IXTA 220N075T	92	IXTP 6N50P	83
IXGH 32N90B2D1	77	IXGT 24N170AH1	79	IXSH 30N60C	74	IXTA 220N075T7	92	IXTP 7N60P	83
IXGH 35N120B	76	IXGT 25N160	78	IXSH 35N120B	74	IXTA 240N055T	92	IXTP 8N50P	83
IXGH 40N120A2	75	IXGT 28N120B	76	IXSH 35N140A	74	IXTA 240N055T7	92	IXTP 8N50PM	83
IXGH 40N120B2D1	77	IXGT 30N120B3D1	77	IXSH 40N60B	74	IXTB 30N100L	90	IXTP 10N60P	83
IXGH 40N60B2	76	IXGT 30N60B2	76	IXSH 40N60B2D1	75	IXTB 62N50L	90	IXTP 10N60PM	83
IXGH 40N60B2D1	77	IXGT 30N60B2D1	77	IXSH 45N120B	74	IXTC 26N50P	83	IXTP 12N50P	83
IXGH 40N60C2	77	IXGT 30N60C2	77	IXSH 50N60B	74	IXTC 180N10T	55, 93	IXTP 12N50PM	83
IXGH 40N60C2D1	78	IXGT 30N60C2D1	78	IXSK 35N120BD1	75	IXTC 200N085T	55, 93	IXTP 14N60P	83
IXGH 50N60B2	76	IXGT 32N170	78	IXSK 80N60B	74	IXTC 200N10T	55, 93	IXTP 16N50P	83
IXGH 50N60C2	77	IXGT 32N170A	79	IXSP 10N60B2D1	75	IXTC 220N075T	55, 92	IXTP 36N30P	82
IXGH 50N90B2	76	IXGT 32N90B2	76	IXSP 15N120B	74	IXTC 230N085T	55, 93	IXTP 42N25P	82
IXGH 50N90B2D1	77	IXGT 32N90B2D1	77	IXSP 20N60B2D1	75	IXTC 240N055T	55, 92	IXTP 44N10T	93
IXGH 60N60	75	IXGT 35N120B	76	IXSP 24N60B	74	IXTC 250N075T	55, 92	IXTP 50N085T	92
IXGH 60N60B2	76	IXGT 40N120A2	75	IXSQ 10N60B2D1	75	IXTC280N055T	55, 92	IXTP 50N20P	82
IXGH 60N60C2	77	IXGT 40N120B2D1	77	IXSQ 20N60B2D1	75	IXTH 1N100	89	IXTP 50N20PM	82
IXGJ 40N60C2D1	78	IXGT 40N60B2	76	IXSR 35N120BD1	75	IXTH 3N120	89	IXTP 55N075T	92
IXGK 35N120B	76	IXGT 40N60B2D1	77	IXST 15N120B	74	IXTH 6N120	89	IXTP 60N10T	93
IXGK 50N60B2D1	77	IXGT 40N60C2	77	IXST 15N120BD1	75	IXTH 8P50	90	IXTP 62N15P	82
IXGK 50N60C2D1	78	IXGT 40N60C2D1	78	IXST 24N60B	74	IXTH 10N100D	89	IXTP 64N055T	92
IXGK 60N60	75	IXGT 50N60B2	76	IXST 30N60B	74	IXTH 10P60	90	IXTP 70N085T	92
IXGK 60N60B2D1	77	IXGT 50N60C2	77	IXST 30N60B2D1	75	IXTH 11P50	90	IXTP 75N10P	82
IXGK 60N60C2D1	78	IXGT 50N90B2	76	IXST 30N60C	74	IXTH 12N100L	90	IXTP 76N075T	92
IXGK 120N60B	76	IXGT 50N90B2D1	77	IXST 35N120B	74	IXTH 12N120	89	IXTP 80N10T	93
IXGK 120N60C2	77	IXGT 60N60	75	IXST 40N60B	74	IXTH 16P20	90	IXTP 88N085T	93
IXGK 400N30A3	76	IXGT 60N60B2	76	IXST 40N60B2D1	75	IXTH 20N50D	89	IXTP 90N055T	92
IXGN 60N60	75	IXGT 60N60C2	77	IXST 45N120B	74	IXTH 22N50P	83	IXTP 98N075T	92
IXGN 60N60C2	77	IXGT 60N60C2D1	78	IXSX 35N120BD1	75	IXTH 24N50L	90	IXTP 110N055P	82
IXGN 60N60C2D1	78	IXGX 32N170AH1	79	IXSX 80N60B	74	IXTH 24P20	90	IXTP 110N055T	92
IXGN 80N60A2	75	IXGX 32N170H1	78	IXTA 05N100	89	IXTH 26N60P	84	IXTP 130N10T	93
IXGN 200N60A2	75	IXGX 35N120B	76	IXTA 1N100	89	IXTH 30N50P	83	IXTP 152N085T	93
IXGN 200N60B	76	IXGX 50N60B2D1	77	IXTA 1N80	89	IXTH 30N60P	84	IXTP 160N075T	92
IXGN 320N60A3	76	IXGX 50N60C2D1	78	IXTA 2N80	89	IXTH 36N50P	83	IXTP 160N10T	93
IXGN 400N30A3	76	IXGX 60N60B2D1	77	IXTA 2N80P	84	IXTH 36P10	90	IXTP 180N085T	93
IXGP 7N60B	76	IXGX 60N60C2D1	78	IXTA 3N120	89	IXTH 50P085	90	IXTP 180N10T	93
IXGP 7N60C	76	IXGX 120N60B	76	IXTA 3N50P	83	IXTH 50P10	90	IXTP 182N055T	92
IXGP 8N100	75	IXGX 120N60C2	77	IXTA 3N60P	83	IXTH 88N30P	82	IXTP 200N075T	92
IXGP 14N120B	76	IXGX 400N30A3	76	IXTA 4N60P	83	IXTH 96N20P	82	IXTP 200N085T	93
IXGP 15N120B	76	IXH 611P1	140	IXTA 4N80P	84	IXTH 200N10T	93	IXTP 220N055T	92
IXGP 15N120B2	76	IXH 611S1	140	IXTA 5N50P	83	IXTH 230N085T	93	IXTP 220N075T	92
IXGP 16N60B2	76	IXI 848AS1	146	IXTA 5N60P	83	IXTH 250N075T	92	IXTP 240N055T	92
IXGP 16N60B2D1	77	IXI 848S1	146	IXTA 6N50P	83	IXTH 280N055T	92	IXTQ 14N60P	83
IXGP 16N60C2	77	IXI 858S1	146	IXTA 7N60P	83	IXTI 10N60P	83	IXTQ 16N50P	83
IXGP 16N60C2D1	78	IXI 859S1	146	IXTA 8N50P	83	IXTI 12N50P	83	IXTQ 18N60P	84
IXGP 20N100	75	IXJ 611P1	140	IXTA 10N60P	83	IXTK 22N100L	90	IXTQ 22N50P	83
IXGP 20N120	75	IXJ 611S1	140	IXTA 14N60P	83	IXTK 46N50L	90	IXTQ 22N60P	84
IXGP 30N60B2	76	IXK 611P1	140	IXTA 16N50P	83	IXTK 82N25P	82	IXTQ 26N50P	83
IXGP 30N60C2	77	IXK 611S1	140	IXTA 36N30P	82	IXTK 88N30P	82	IXTQ 26N60P	84
IXGQ 20N120B	76	IXKC 13N80C	55, 91	IXTA 42N25P	82	IXTK 100N25P	82	IXTQ 30N50P	83
IXGR 16N170AH1	79	IXKC 20N60C	55, 91	IXTA 50N20P	82	IXTK 102N30P	82	IXTQ 30N60P	84
IXGR 32N170AH1	79	IXKC 25N80C	55, 91	IXTA 62N15P	82	IXTK 120N20P	82	IXTQ 36N30P	82
IXGR 32N170H1	78	IXKC 40N60C	55, 91	IXTA 75N10P	82	IXTK 120N25P	82	IXTQ 36N50P	83
IXGR 32N90B2D1	77	IXKF 40N60SCD1	58, 91	IXTA 80N10T	93	IXTK 140N20P	82	IXTQ 42N25P	82
IXGR 35N120B	56, 76	IXKH 35N60C5	91	IXTA 80N10T7	93	IXTK 150N15P	82	IXTQ 44N50P	83
IXGR 40N60B2	56, 76	IXKH 47N60C	91	IXTA 88N085T	92	IXTK 170N10P	82	IXTQ 50N20P	82
IXGR 40N60B2D1	77	IXKH 70N60C5	91	IXTA 88N085T7	92	IXTK 180N15P	82	IXTQ 52N30P	82
IXGR 40N60C2	56, 77	IXKK 85N60C	91	IXTA 98N075T	92	IXTK 200N10P	82	IXTQ 62N15P	82
IXGR 40N60C2D1	78	IXKL 34N100	56	IXTA 98N075T7	92	IXTK 250N10	89	IXTQ 64N25P	82
IXGR 50N60B2	56, 76	IXKL 60N80P	56	IXTA 110N055P	82	IXTN 22N100L	90	IXTQ 69N30P	82
IXGR 50N60B2D1	77	IXKN 40N60C	91	IXTA 110N055T	92	IXTN 30N100L	90	IXTQ 74N20P	82
IXGR 50N60C2	56, 77	IXKN 45N80C	91	IXTA 110N055T7	92	IXTN 46N50L	90	IXTQ 75N10P	82
IXGR 50N60C2D1	78	IXKN 75N60C	91	IXTA 130N10T	93	IXTN 62N50L	90	IXTQ 82N25P	82
IXGR 50N90B2D1	77	IXKP 35N60C5	91	IXTA 130N10T7	93	IXTP 01N100D	89	IXTQ 88N30P	82
IXGR 60N60B2	56, 76	IXKR 25N80C	56, 91	IXTA 152N085T	93	IXTR 02N 50D	89	IXTQ 96N15P	82
IXGR 60N60B2D1	77	IXKR 40N60C	56, 91	IXTA 152N085T7	93	IXTP 05N100	89	IXTQ 96N20P	82
IXGR 60N60C2	56, 77	IXLF 19N250A	58, 79	IXTA 160N075T	92	IXTP 1N100	89	IXTQ 100N25P	82
IXGR 60N60C2D1	78	IXRH 40N120	80, 121	IXTA 160N075T7	92	IXTP 1N80	89	IXTQ 110N055P	82
IXGR 120N60B	56, 76	IXRP 15N120	80, 121	IXTA 160N10T	93	IXTP 1R4N60P	83	IXTQ 110N10P	82
IXGR 120N60C2	56, 77	IXRR 40N120	80, 121	IXTA 160N10T7	93	IXTP 1R6N50P	83	IXTQ 120N15P	82
IXGT 6N170	78	IXS 839AQ2	145	IXTA 180N085T	93	IXTP 2N100	89	IXTQ 120N20P	82
IXGT 6N170A	79	IXS 839BQ2	145	IXTA 180N085T7	93	IXTP 2N60P	83	IXTQ 130N10T	93
IXGT 10N170	78	IXS 839S1	145	IXTA 180N10T	93	IXTP 2N80	89	IXTQ 140N10P	82

Alphanumeric Index

➤ new

➤ IXTQ 150N06P	82	➤ IXTV 280N055T	92	MCC 72-14io8B	116	MCD 40-12io6	113	MCD 310-16io1	114
➤ IXTQ 150N15P	82	➤ IXTV 280N055TS	92	MCC 72-16io1B	116	MCD 40-16io6	113	MCD 310-18io1	114
➤ IXTQ 152N085T	93	➤ IXTX 22N100L	90	MCC 72-16io8B	116	MCD 44-08io1B	113	MCD 310-20io1	114
➤ IXTQ 160N075T	92	➤ IXTX 46N50L	90	MCC 72-18io1B	116	MCD 44-08io8B	113	MCD 310-22io1	114
➤ IXTQ 160N10T	93	IXTY 01N100	89	MCC 72-18io8B	116	MCD 44-12io1B	113	MCD 312-12io1	114
➤ IXTQ 170N10P	82	➤ IXTY 01N100D	89	MCC 94-20io1B	116	MCD 44-12io8B	113	MCD 312-14io1	114
➤ IXTQ 180N085T	93	IXTY 01N80	89	MCC 94-22io1B	116	MCD 44-14io1B	113	MCD 312-16io1	114
➤ IXTQ 180N10T	93	➤ IXTY 02N50D	89	MCC 95-08io1B	116	MCD 44-14io8B	113	MCD 312-18io1	114
➤ IXTQ 182N055T	92	IXTY 1N80	89	MCC 95-08io8B	117	MCD 44-16io1B	113	MCD 500-12io1	114
➤ IXTQ 200N06P	82	➤ IXTY 1R4N60P	83	MCC 95-12io1B	116	MCD 44-16io8B	113	MCD 500-16io1	114
➤ IXTQ 200N075T	92	➤ IXTY 1R6N50P	83	MCC 95-12io8B	117	MCD 44-18io1B	113	MCD 500-18io1	114
➤ IXTQ 200N085T	93	➤ IXTY 2N80P	84	MCC 95-14io1B	116	MCD 44-18io8B	113	MCD 500-22io1	114
➤ IXTQ 200N10T	93	➤ IXTY 2R4N50P	83	MCC 95-14io8B	117	MCD 56-08io1B	113	MCD 700-12io1W	114
➤ IXTQ 220N055T	92	➤ IXTY 3N50P	83	MCC 95-16io1B	116	MCD 56-08io8B	113	MCD 700-16io1W	114
➤ IXTQ 220N075T	92	➤ IXTY 3N60P	83	MCC 95-16io8B	117	MCD 56-12io1B	113	MCD 700-18io1W	114
➤ IXTQ 230N085T	93	➤ IXTY 5N50P	83	MCC 95-18io1B	116	MCD 56-12io8B	113	MCO 25-12io6	118
➤ IXTQ 240N055T	92	➤ IXTY 2N60P	83	MCC 95-18io8B	117	MCD 56-14io1B	113	MCO 25-16io6	118
➤ IXTQ 250N075T	92	➤ IXTY 44N10T	93	MCC 132-08io1	117	MCD 56-14io8B	113	MCO 50-12io6	118
➤ IXTQ 280N055T	92	➤ IXTY 50N085T	92	MCC 132-12io1	117	MCD 56-16io1B	113	MCO 50-16io6	118
➤ IXTR 200N10P	56, 82	➤ IXTY 55N075T	92	MCC 132-14io1	117	MCD 56-16io8B	113	➤ MCO 75-12io6	118
IXTT 1N100	89	➤ IXTY 60N10T	93	MCC 132-16io1	117	MCD 56-18io1B	113	➤ MCO 75-16io6	118
IXTT 6N120	89	➤ IXTY 64N055T	92	MCC 132-18io1	117	MCD 56-18io8B	113	MCO 100-12io6	118
➤ IXTT 8P50	90	➤ IXTY 70N085T	92	MCC 161-20io1	117	MCD 72-08io1B	113	MCO 100-16io6	118
➤ IXTT 10N100D	89	➤ IXTY 76N075T	92	MCC 161-22io1	117	MCD 72-08io8B	113	MCO 150-12io1	118
IXTT 11P50	90	➤ IXTY 90N055T	92	MCC 162-08io1	117	MCD 72-12io1B	113	MCO 150-16io1	118
➤ IXTT 20N50D	89	IXUC 60N10	55, 91	MCC 162-12io1	117	MCD 72-12io8B	113	MCO 450-20io1	118
➤ IXTT 24P20	90	IXUC 100N055	55, 91	MCC 162-14io1	117	MCD 72-14io1B	113	MCO 450-22io1	118
➤ IXTT 26N50P	83	IXUC 120N10	55, 91	MCC 162-16io1	117	MCD 72-14io8B	113	MCO 500-12io1	118
➤ IXTT 26N60P	84	IXUC 160N075	55, 91	MCC 162-18io1	117	MCD 72-16io1B	113	MCO 500-14io1	118
➤ IXTT 30N50P	83	IXUC 200N055	55, 91	MCC 170-12io1	117	MCD 72-16io8B	113	MCO 500-16io1	118
➤ IXTT 30N60P	84	➤ IXUN 280N10	91	MCC 170-14io1	117	MCD 72-18io1B	113	MCO 500-18io1	118
➤ IXTT 36N50P	83	➤ IXUN 350N10	91	MCC 170-16io1	117	MCD 72-18io8B	113	MCO 600-16io1	118
➤ IXTT 50P10	90	IXUV 170N075	91	MCC 170-18io1	117	MCD 94-20io1B	113	MCO 600-18io1	118
IXTT 52N30P	82	IXUV 170N075S	91	MCC 200-14io1	117	MCD 94-22io1B	113	MCO 600-20io1	118
IXTT 64N25P	82	M		MCC 200-16io1	117	MCD 95-08io1B	113	MCO 600-22io1	118
IXTT 69N30P	82	MCC 19-08io1B	116	MCC 200-18io1	117	MCD 95-08io8B	113	MDD 26-08N1B	111
IXTT 74N20P	82	MCC 19-08io8B	116	MCC 220-08io1	117	MCD 95-12io1B	113	MDD 26-12N1B	111
IXTT 82N25P	82	MCC 19-12io1B	116	MCC 220-12io1	117	MCD 95-12io8B	113	MDD 26-14N1B	111
IXTT 88N30P	82	MCC 19-12io8B	116	MCC 220-14io1	117	MCD 95-14io1B	113	MDD 26-16N1B	111
IXTT 96N15P	82	MCC 19-14io1B	116	MCC 220-16io1	117	MCD 95-14io8B	113	MDD 26-18N1B	111
IXTT 96N20P	82	MCC 19-14io8B	116	MCC 220-18io1	117	MCD 95-16io1B	113	MDD 44-08N1B	111
IXTT 100N25P	82	MCC 19-16io1B	116	MCC 224-20io1	117	MCD 95-16io8B	113	MDD 44-12N1B	111
IXTT 110N10P	82	MCC 19-16io8B	116	MCC 224-22io1	117	MCD 95-18io1B	113	MDD 44-14N1B	111
➤ IXTT 120N15P	82	MCC 21-08io8B	116	MCC 225-12io1	117	MCD 95-18io8B	113	MDD 44-16N1B	111
IXTT 140N10P	82	MCC 21-12io8B	116	MCC 225-14io1	117	MCD 132-08io1	113	MDD 44-18N1B	111
➤ IXTT 170N10P	82	MCC 21-14io8B	116	MCC 225-16io1	117	MCD 132-12io1	113	MDD 56-08N1B	111
IXTU 01N100	89	MCC 21-16io8B	116	MCC 225-18io1	117	MCD 132-14io1	113	MDD 56-12N1B	111
➤ IXTU 01N100D	89	MCC 26-08io1B	116	MCC 250-08io1	117	MCD 132-16io1	113	MDD 56-14N1B	111
IXTU 01N80	89	MCC 26-08io8B	116	MCC 250-12io1	117	MCD 132-18io1	113	MDD 56-16N1B	111
➤ IXTU 02N50D	89	MCC 26-12io1B	116	MCC 250-14io1	117	MCD 161-20io1	113	MDD 56-18N1B	111
➤ IXTU 1R4N60P	83	MCC 26-12io8B	116	MCC 250-16io1	117	MCD 161-22io1	113	MDD 72-08N1B	111
➤ IXTU 44N10T	93	MCC 26-14io1B	116	MCC 250-18io1	117	MCD 162-08io1	114	MDD 72-12N1B	111
➤ IXTU 50N085T	92	MCC 26-14io8B	116	MCC 255-12io1	117	MCD 162-12io1	114	MDD 72-14N1B	111
➤ IXTU 55N075T	92	MCC 26-16io1B	116	MCC 255-14io1	117	MCD 162-14io1	114	MDD 72-16N1B	111
➤ IXTU 60N10T	93	MCC 26-16io8B	116	MCC 255-16io1	117	MCD 162-16io1	114	MDD 72-18N1B	111
➤ IXTU 64N055T	92	MCC 44-08io1B	116	MCC 255-18io1	117	MCD 162-18io1	114	MDD 95-08N1B	111
➤ IXTU 70N085T	92	MCC 44-08io8B	116	MCC 310-08io1	117	MCD 200-14io1	114	MDD 95-12N1B	111
➤ IXTU 76N075T	92	MCC 44-12io1B	116	MCC 310-12io1	117	MCD 200-16io1	114	MDD 95-14N1B	111
➤ IXTU 90N055T	92	MCC 44-12io8B	116	MCC 310-14io1	117	MCD 200-18io1	114	MDD 95-16N1B	111
➤ IXTV 18N60P	83	MCC 44-14io1B	116	MCC 310-16io1	117	MCD 220-08io1	114	MDD 95-18N1B	111
➤ IXTV 18N60PS	84	MCC 44-14io8B	116	MCC 310-18io1	117	MCD 220-12io1	114	MDD 95-20N1B	111
➤ IXTV 22N50P	83	MCC 44-16io1B	116	MCC 312-12io1	117	MCD 220-14io1	114	MDD 95-22N1B	111
➤ IXTV 22N50PS	83	MCC 44-16io8B	116	MCC 312-14io1	117	MCD 220-16io1	114	MDD 142-08N1	111
➤ IXTV 22N60P	84	MCC 44-18io1B	116	MCC 312-16io1	117	MCD 224-20io1	114	MDD 142-12N1	111
➤ IXTV 22N60PS	84	MCC 44-18io8B	116	MCC 312-18io1	117	MCD 224-22io1	114	MDD 142-14N1	111
➤ IXTV 26N50P	83	MCC 56-08io1B	116	MCC 500-12io1	117	MCD 225-12io1	114	MDD 142-16N1	111
➤ IXTV 26N50PS	83	MCC 56-08io8B	116	MCC 500-14io1	117	MCD 225-14io1	114	MDD 142-18N1	111
➤ IXTV 26N60P	84	MCC 56-12io1B	116	MCC 500-16io1	117	MCD 225-16io1	114	MDD 172-08N1	111
➤ IXTV 26N60PS	84	MCC 56-12io8B	116	MCC 500-18io1	117	MCD 225-18io1	114	MDD 172-12N1	111
➤ IXTV 30N50P	83	MCC 56-14io1B	116	MCC 500-22io1	117	MCD 250-08io1	114	MDD 172-14N1	111
➤ IXTV 30N50PS	83	MCC 56-14io8B	116	MCC 700-12io1W	117	MCD 250-12io1	114	MDD 172-16N1	111
➤ IXTV 30N60P	84	MCC 56-16io1B	116	MCC 700-16io1W	117	MCD 250-14io1	114	MDD 172-18N1	111
➤ IXTV 30N60PS	84	MCC 56-16io8B	116	MCC 700-18io1W	117	MCD 250-16io1	114	MDD 200-14N1	111
➤ IXTV 36N50P	83	MCC 56-18io1B	116	MCD 26-08io1B	113	MCD 250-18io1	114	MDD 200-16N1	111
➤ IXTV 36N50PS	83	MCC 56-18io8B	116	MCD 26-08io8B	113	MCD 255-12io1	114	MDD 200-18N1	111
➤ IXTV 200N10T	93	MCC 72-08io1B	116	MCD 26-12io1B	113	MCD 255-14io1	114	MDD 200-22N1	111
➤ IXTV 200N10TS	93	MCC 72-08io8B	116	MCD 26-12io8B	113	MCD 255-16io1	114	MDD 220-08N1	112
➤ IXTV 230N085T	93	MCC 72-12io1B	116	MCD 26-14io1B	113	MCD 255-18io1	114	MDD 220-12N1	112
➤ IXTV 230N85TS	93	MCC 72-12io8B	116	MCD 26-14io8B	113	MCD 310-08io1	114	MDD 220-14N1	112
➤ IXTV 250N075T	92	MCC 72-12io8B	116	MCD 26-16io1B	113	MCD 310-12io1	114	MDD 220-16N1	112
➤ IXTV 250N075TS	92	MCC 72-14io1B	116	MCD 26-16io8B	113	MCD 310-14io1	114	MDD 220-18N1	112

Alphanumeric Index

► new

MDD 250-08N1	112	MII 75-12A3	69	► MUBW 25-12T7	64	VBO 13-12AO2	124	VBO 78-12NO7	125
MDD 250-12N1	112	MII 100-12A3	69	MUBW 30-06A7	64	VBO 13-12NO2	124	VBO 78-14NO7	125
MDD 250-14N1	112	MII 145-12A3	69	MUBW 30-12A6K	64	VBO 13-14AO2	124	VBO 78-16NO7	125
MDD 250-16N1	112	MII 150-12A4	69	► MUBW 30-12E6K	64	VBO 13-14NO2	124	VBO 78-18NO7	125
MDD 255-12N1	112	MII 200-12A4	69	MUBW 35-06A6K	64	VBO 13-16AO2	124	VBO 88-08NO7	125
MDD 255-14N1	112	MII 300-12A4	69	MUBW 35-12A7	64	VBO 13-16NO2	124	VBO 88-12NO7	125
MDD 255-16N1	112	MII 400-12E4	69	MUBW 35-12A8	65	VBO 19-08NO7	124	VBO 88-14NO7	125
MDD 255-18N1	112	► MIO 600-65E11	70	MUBW 35-12E7	64	VBO 19-12NO7	124	VBO 88-16NO7	125
MDD 255-20N1	112	► MIO 1200-25E10	70	► MUBW 40-12T7	64	VBO 20-08NO2	124	VBO 88-18NO7	125
MDD 255-22N1	112	MIO 1200-33E10	70	► MUBW 45-12T6K	64	VBO 20-12AO2	124	VBO 105-08NO7	125
MDD 310-08N1	112	► MIO 1200-33E11	70	MUBW 50-06A7	64	VBO 20-12NO2	124	VBO 105-12NO7	125
MDD 310-12N1	112	► MIO 1500-25E10	70	MUBW 50-06A8	65	VBO 20-14AO2	124	VBO 105-14NO7	125
MDD 310-14N1	112	MIO 1800-17E10	70	MUBW 50-12A8	65	VBO 20-14NO2	124	VBO 105-16NO7	125
MDD 310-16N1	112	MIO 2400-17E10	70	MUBW 50-12E8	65	VBO 20-16AO2	124	VBO 105-18NO7	125
MDD 310-18N1	112	► MITA 10WB1200TMH	63	► MUBW 50-12T8	65	VBO 20-16NO2	124	VBO 125-08NO7	125
MDD 310-20N1	112	► MITA 30WB600TMH	63	► MUBW 50-17T8	65	VBO 21-08NO7	124	VBO 125-12NO7	125
MDD 310-22N1	112	► MITB 10WB1200TMH	63	MUBW 75-06A8	65	VBO 21-12NO7	124	VBO 125-14NO7	125
MDD 312-12N1	112	► MITB 15WB1200TMH	63	MUBW 75-12T8	65	VBO 22-08NO8	124	VBO 125-16NO7	125
MDD 312-14N1	112	MKI 50-06A7	68	► MUBW 75-17T8	65	VBO 22-12NO8	124	VBO 125-18NO7	125
MDD 312-16N1	112	► MKI 50-12E7	68	MUBW 100-06A8	65	VBO 22-14NO8	124	VBO 130-08NO7	125
MDD 312-18N1	112	► MKI 50-12F7	68	► MWI 15-12A6K	66	VBO 22-16NO8	124	VBO 130-12NO7	125
MDD 312-20N1	112	MKI 75-06A7	68	MWI 15-12A7	66	VBO 22-18NO8	124	VBO 130-14NO7	125
MDD 312-22N1	112	MKI 75-12E8	68	MWI 25-12A7	66	VBO 25-08NO2	124	VBO 130-16NO7	125
MDD 600-12N1	112	MKI 100-12E8	68	► MWI 25-12E7	66	VBO 25-12AO2	124	VBO 130-18NO7	125
MDD 600-16N1	112	► MKI 100-12F8	68	MWI 30-06A7	66	VBO 25-12NO2	124	VBO 160-08NO7	125
MDD 600-18N1	112	MLO 36-12io1	134	► MWI 30-12E6K	66	VBO 25-14AO2	124	VBO 160-12NO7	125
MDD 600-22N1	112	MLO 36-16io1	134	MWI 35-12A7	66	VBO 25-14NO2	124	VBO 160-14NO7	125
► MDD 950-12N1W	112	MLO 75-12io1	134	► MWI 45-12T6K	66	VBO 25-16AO2	124	VBO 160-16NO7	125
► MDD 950-16N1W	112	MLO 75-16io1	134	MWI 50-06A7	66	VBO 25-16NO2	124	VBO 160-18NO7	125
► MDD 950-18N1W	112	MLO 110-08io7	134	MWI 50-12A7	66	VBO 30-08NO7	124	VCA 105-06io7	115
► MDD 950-22N1W	112	MLO 110-12io7	134	► MWI 50-12E6K	66	VBO 30-12NO7	124	VCA 105-12io7	115
MDI 75-12A3	69	MLO 110-14io7	134	MWI 50-12E7	66	VBO 30-14NO7	124	VCA 105-14io7	115
MDI 100-12A3	69	MLO 140-08io7	134	► MWI 50-12T7	66	VBO 30-16NO7	124	VCA 105-16io7	115
MDI 145-12A3	69	MLO 140-12io7	134	► MWI 60-06G6K	66	VBO 30-18NO7	124	VCA 105-18io7	115
MDI 150-12A4	69	MLO 140-16io7	134	MWI 60-12T6K	66	VBO 36-08NO8	124	VCC 2X105-06io7	115
MDI 200-12A4	69	MLO 175-08io7	134	MWI 75-06A7	66	VBO 36-12NO8	124	VCC 2X105-12io7	115
MDI 300-12A4	69	MLO 175-12io7	134	MWI 75-12A8	67	VBO 36-14NO8	124	VCC 2X105-14io7	115
MDI 400-12E4	69	MLO 175-16io7	134	MWI 75-12E8	67	VBO 36-16NO8	124	VCC 2X105-16io7	115
MDI 550-12A4	69	MLO 230-08io7	134	► MWI 75-12T7	66	VBO 36-18NO8	124	VCC 2X105-18io7	115
MDO 500-12N1	112	MLO 230-12io7	134	► MWI 75-12T8	67	VBO 40-08NO6	124	VCC 105-06io7	115
MDO 500-14N1	112	MLO 230-14io7	134	MWI 80-12T6K	66	VBO 40-12NO6	124	VCC 105-12io7	115
MDO 500-16N1	112	MLO 230-16io7	134	MWI 100-06A8	67	VBO 40-16NO6	124	VCC 105-14io7	115
MDO 500-18N1	112	MLO 230-18io7	134	MWI 100-12A8	67	VBO 45-08NO7	124	VCC 105-16io7	115
MDO 500-20N1	112	MMO 36-12io1	134	MWI 100-12E8	67	VBO 45-12NO7	124	VCC 105-18io7	115
MDO 500-22N1	112	MMO 36-16io1	134	► MWI 100-12T8	67	VBO 45-14NO7	124	VCD 105-06io7	115
MEA 75-12DA	106	MMO 62-12io6	134	MWI 150-06A8	67	VBO 45-16NO7	124	VCD 105-12io7	115
MEA 95-06DA	106	MMO 62-16io6	134	► MWI 150-12T8	67	VBO 45-18NO7	124	VCD 105-14io7	115
MEA 250-12DA	106	MMO 74-12io6	134	MWI 200-06A8	67	VBO 50-08NO7	125	VCD 105-16io7	115
MEA 300-06DA	106	MMO 74-16io6	134	► MWI 225-12E9	67	VBO 50-12NO7	125	VCD 105-18io7	115
MEE 75-12DA	106	MMO 75-12io1	134	► MWI 225-17E9	67	VBO 50-14NO7	125	VCK 105-06io7	115
MEE 95-06DA	106	MMO 75-16io1	134	► MWI 300-12E9	67	VBO 50-16NO7	125	VCK 105-12io7	115
MEE 250-12DA	106	MMO 90-12io6	134	► MWI 300-17E9	67	VBO 50-18NO7	125	VCK 105-14io7	115
MEE 300-06DA	106	MMO 90-14io6	134	► MWI 450-12E9	67	VBO 52-08NO7	125	VCK 105-16io7	115
MEK 75-12DA	106	MMO 90-16io6	134	► MWI 450-17E9	67	VBO 52-12NO7	125	VCK 105-18io7	115
MEK 95-06DA	106	MMO 110-08io7	134	► MX 841	145	VBO 52-14NO7	125	VCO 132-08io7	115
MEK 150-04DA	106	MMO 110-12io7	134	T		VBO 52-16NO7	125	VCO 132-12io7	115
MEK 250-12DA	106	MMO 110-14io7	134	TX02-4400JI	141	VBO 52-18NO7	125	VCO 132-14io7	115
MEK 300-06DA	106	MMO 140-08io7	134	TX02-4400PI	141	VBO 54-08NO7	125	VCO 132-16io7	115
MEK 350-02DA	106	MMO 140-12io7	134	U		VBO 54-12NO7	125	VCO 132-18io7	115
MEK 600-04DA	106	MMO 140-16io7	134	UGB 3132AD	128	VBO 54-14NO7	125	VCO 180-08io7	115
MEO 450-12DA	106	MMO 175-08io7	134	UGB 6124AG	128	VBO 54-16NO7	125	VCO 180-12io7	115
MEO 500-06DA	106	MMO 175-12io7	134	UGD 6123AG	128	VBO 55-08NO7	125	VCO 180-14io7	115
MEO 550-02DA	106	MMO 175-16io7	134	UGD 8124AG	128	VBO 55-12NO7	125	VCO 180-16io7	115
► MIAA 10WB600TMH	63	MMO 230-08io7	134	UGE 0221AY4	128	VBO 55-14NO7	125	VCO 180-18io7	115
► MIAA 10WD600TMH	63	MMO 230-12io7	134	UGE 0421AY4	128	VBO 55-16NO7	125	VDI 25-06P1	71
► MIAA 10WE600TMH	63	MMO 230-14io7	134	UGE 1112AY4	128	VBO 55-18NO7	125	VDI 25-12P1	71
► MIAA 10WF600TMH	63	MMO 230-16io7	134	UGE 3126AY4	128	VBO 65-08NO7	125	VDI 50-06P1	71
► MIAA 15WB600TMH	63	MMO 230-18io7	134	V		VBO 65-12NO7	125	VDI 50-12P1	71
► MIAA 15WD600TMH	63	► MPK 95-06DA	106	VBE 17-06NO7	123	VBO 65-14NO7	125	VDI 75-06P1	71
► MIAA 15WE600TMH	63	MUBW 10-06A6K	64	VBE 17-12NO7	123	VBO 65-16NO7	125	VDI 75-12P1	71
► MIAA 20WB600TMH	63	MUBW 10-06A7	64	VBE 20-20NO1	123	VBO 65-18NO7	125	VDI 100-06P1	71
► MIAA 20WD600TMH	63	MUBW 10-12A7	64	VBE 26-06NO7	123	VBO 68-08NO7	125	VDI 125-12P1	71
► MIAA 20WE600TMH	63	MUBW 15-06A6K	64	VBE 26-12NO7	123	VBO 68-12NO7	125	VDI 130-06P1	71
MID 75-12A3	69	MUBW 15-06A7	64	VBE 55-06NO7	123	VBO 68-14NO7	125	VDI 160-12P1	71
MID 100-12A3	69	MUBW 15-12A6K	64	VBE 55-12NO7	123	VBO 68-16NO7	125	VGf 0124AY7A	136
MID 145-12A3	69	MUBW 15-12A7	64	VBE 60-06A	123	VBO 72-08NO7	125	VGB 0136AB	136
MID 150-12A4	69	► MUBW 15-12T7	64	VBE 100-06NO7	123	VBO 72-12NO7	125	VGf 0136AH	136
MID 200-12A4	69	MUBW 20-06A6K	64	VBE 100-06NO7	123	VBO 72-14NO7	125	VGO 36-08io7	127
MID 300-12A4	69	MUBW 20-06A7	64	VBE 100-12NO7	123	VBO 72-16NO7	125	VGO 36-12io7	127
MID 400-12E4	69	MUBW 25-06A6K	64	VBH 40-05B	122	VBO 72-18NO7	125	VGO 36-14io7	127
MID 550-12A4	69	MUBW 25-12A7	64	VBO 13-08NO2	124	VBO 78-08NO7	125	VGO 36-16io7	127

Alphanumeric Index

► new

VGO 55-08io7	127	VKM 60-01P1	94	VUO 22-12NO1	129	VUO 86-14NO7	130	VW 2x60-12io1	134
VGO 55-12io7	127	VKO 55-08io7	127	VUO 22-14NO1	129	VUO 86-16NO7	130	VW 2x60-14io1	134
VGO 55-14io7	127	VKO 55-12io7	127	VUO 22-16NO1	129	VUO 98-08NO7	130	VW 2x60-16io1	134
VGO 55-16io7	127	VKO 55-14io7	127	VUO 22-18NO1	129	VUO 98-12NO7	130	VWI 6-12P1	72
VHF 15-08io5	126	VKO 55-16io7	127	VUO 25-08NO8	129	VUO 98-14NO7	130	VWI 15-12P1	72
VHF 15-12io5	126	VMK 90-02T2	94, 121	VUO 25-12NO8	129	VUO 98-16NO7	130	VWI 20-06P1	72
VHF 15-14io5	126	VMK 165-007T	94, 121	VUO 25-14NO8	129	VUO 100-08NO7	130	VWI 35-06P1	72
VHF 15-16io5	126	VMM 45-02F	94	VUO 25-16NO8	129	VUO 100-12NO7	130	VWI 3X20-06P1	72
VHF 25-06io7	126	VMM 85-02F	94	VUO 25-18NO8	129	VUO 100-14NO7	130	VWM 200-01P	95
VHF 25-08io7	126	VMM 90-09F	94	VUO 27-08NO7	129	VUO 100-16NO7	130	VWM 350-0075P	95
VHF 25-12io7	126	VMM 300-03F	94	VUO 27-12NO7	129	VUO 105-12NO7	130	VWO 35-08HO7	135
VHF 28-08io5	126	VMM 650-01F	94	VUO 28-08NO7	129	VUO 105-14NO7	130	VWO 35-12HO7	135
VHF 28-12io5	126	VMM 1000-01P	95	VUO 28-12NO7	129	VUO 105-16NO7	130	VWO 36-08io7	135
VHF 28-14io5	126	VMM 1500-0075P	95	VUO 30-08NO3	129	VUO 105-18NO7	130	VWO 36-12io7	135
VHF 28-16io5	126	VMO 40-05P1	94	VUO 30-12NO3	129	VUO 110-08NO7	130	VWO 36-14io7	135
VHF 36-08io5	126	VMO 60-05F	94	VUO 30-14NO3	129	VUO 110-12NO7	130	VWO 36-16io7	135
VHF 36-12io5	126	VMO 80-05P1	94	VUO 30-16NO3	129	VUO 110-14NO7	130	VWO 40-08io7	135
VHF 36-14io5	126	VMO 150-01P1	94	VUO 30-18NO3	129	VUO 110-16NO7	130	VWO 40-12io7	135
VHF 36-16io5	126	VMO 550-01F	94	VUO 34-08NO1	129	VUO 110-18NO7	130	VWO 40-14io7	135
VHF 55-08io7	126	VMO 580-02F	94	VUO 34-12NO1	129	VUO 120-12NO1	131	VWO 40-16io7	135
VHF 55-12io7	126	VMO 650-01F	94	VUO 34-14NO1	129	VUO 120-16NO1	131	VWO 50-08io7	135
VHF 55-14io7	126	► VMO 1200-01F	94	VUO 34-16NO1	129	VUO 121-16NO1	131	VWO 50-12io7	135
VHF 55-16io7	126	VTO 39-08HO7	133	VUO 34-18NO1	129	VUO 122-08NO7	131	VWO 50-14io7	135
VHF 85-12io7	126	VTO 39-12HO7	133	VUO 35-08NO7	129	VUO 122-12NO7	131	VWO 50-16io7	135
VHF 85-14io7	126	VTO 70-08io7	133	VUO 35-12NO7	129	VUO 122-14NO7	131	VWO 60-08io7	135
VHF 125-12io7	126	VTO 70-12io7	133	VUO 35-14NO7	129	VUO 122-16NO7	131	VWO 60-12io7	135
VHF 125-14io7	126	VTO 70-14io7	133	VUO 35-16NO7	129	VUO 122-18NO7	131	VWO 60-14io7	135
VHF 125-16io7	126	VTO 70-16io7	133	VUO 35-18NO7	129	VUO 125-12NO7	131	VWO 60-16io7	135
VHFD 16-08io1	126	VTO 110-12io7	133	VUO 36-08NO8	129	VUO 125-14NO7	131	VWO 80-08io7	135
VHFD 16-12io1	126	VTO 110-14io7	133	VUO 36-12NO8	129	VUO 125-16NO7	131	VWO 80-12io7	135
VHFD 16-14io1	126	VTO 175-12io7	133	VUO 36-14NO8	129	VUO 125-18NO7	131	VWO 80-14io7	135
VHFD 16-16io1	126	VTO 175-14io7	133	VUO 36-16NO8	129	VUO 155-12NO1	131	VWO 85-08io1	135
VHFD 29-08io1	126	VTO 175-16io7	133	VUO 36-18NO8	129	VUO 155-16NO1	131	VWO 85-12io1	135
VHFD 29-12io1	126	VTOF 70-08io7	133	VUO 50-08NO3	129	VUO 160-08NO7	131	VWO 85-14io1	135
VHFD 29-14io1	126	VTOF 70-12io7	133	VUO 50-12NO3	129	VUO 160-12NO7	131	VWO 85-16io1	135
VHFD 29-16io1	126	VTOF 70-14io7	133	VUO 50-14NO3	129	VUO 160-14NO7	131	VWO 95-08io7	135
VHFD 37-08io1	126	VTOF 70-16io7	133	VUO 50-16NO3	129	VUO 160-16NO7	131	VWO 95-12io7	135
VHFD 37-12io1	126	VUB 33-06P1	122	VUO 50-18NO3	129	VUO 160-18NO7	131	VWO 95-14io7	135
VHFD 37-14io1	126	VUB 50-12PO1	122	VUO 52-08NO1	129	VUO 190-08NO7	131	VWO 140-08io1	135
VHFD 37-16io1	126	VUB 50-16PO1	122	VUO 52-12NO1	129	VUO 190-12NO7	131	VWO 140-12io1	135
VHM 40-06P1	94	VUB 72-12NO1	122	VUO 52-14NO1	129	VUO 190-14NO7	131	VWO 140-14io1	135
VHO 55-08io7	127	VUB 72-16NO1	122	VUO 52-16NO1	129	VUO 190-16NO7	131	VWO 140-16io1	135
VHO 55-12io7	127	VUB 116-16NO1	122	VUO 52-18NO1	129	VUO 190-18NO7	131		
VHO 55-14io7	127	VUB 120-12NO2	122	VUO 52-20NO1	129	VVY 40-16io1	127	X	
VHO 55-16io7	127	VUB 120-16NO2	122	VUO 55-12NO7	129	VVZ 12-12io1	132	► XOB 17-04x3	149
VID 25-06P1	71	► VUB 135-22NO1	122	VUO 55-14NO7	129	VVZ 12-14io1	132	► XOB 17-12x1	149
VID 25-12P1	71	VUB 145-16NO1	122	VUO 55-16NO7	129	VVZ 12-16io1	132	XOD 17-04B	148
VID 50-06P1	71	VUB 160-12NO2	122	VUO 55-18NO7	129	VVZ 24-12io1	132	XOD 17-07B	148
VID 50-12P1	71	VUB 160-16NO2	122	VUO 60-12NO3	129	VVZ 24-14io1	132	XOD 17-12B	148
VID 75-06P1	71	VUBM 33-05P1	122	VUO 60-14NO3	129	VVZ 24-16io1	132	XOD 17-24B	148
VID 75-12P1	71	VUC 25-12go2	132	VUO 60-16NO3	129	VVZ 39-08HO7	132	XOD 17-36B	148
VID 100-06P1	71	VUC 25-14go2	132	VUO 60-18NO3	129	VVZ 39-12HO7	132	XOD 17-48B	148
VID 125-12P1	71	VUC 25-16go2	132	VUO 62-08NO7	130	VVZ 40-12io1	132		
VID 130-06P1	71	VUC 36-12go2	132	VUO 62-12NO7	130	VVZ 40-14io1	132		
VID 160-12P1	71	VUC 36-14go2	132	VUO 62-14NO7	130	VVZ 40-16io1	132		
VII 25-06P1	71	VUC 36-16go2	132	VUO 62-16NO7	130	VVZ 70-08io7	132		
VII 25-12P1	71	VUE 22-06NO7	123	VUO 62-18NO7	130	VVZ 70-12io7	132		
VII 50-06P1	71	VUE 22-12NO7	123	VUO 68-08NO7	130	VVZ 70-14io7	132		
VII 50-12P1	71	VUE 30-20NO1	123	VUO 68-12NO7	130	VVZ 70-16io7	132		
VII 75-06P1	71	VUE 35-06NO7	123	VUO 68-14NO7	130	VVZ 110-12io7	132		
VII 75-12P1	71	VUE 35-12NO7	123	VUO 68-16NO7	130	VVZ 110-14io7	132		
VII 100-06P1	71	VUE 50-12NO1	123	VUO 70-08NO7	130	VVZ 175-12io7	132		
VII 130-06P1	71	VUE 75-06NO7	123	VUO 70-12NO7	130	VVZ 175-14io7	132		
VIO 25-06P1	71	VUE 75-12NO7	123	VUO 70-14NO7	130	VVZ 175-16io7	132		
VIO 25-12P1	71	VUE 130-06NO7	123	VUO 70-16NO7	130	VVZB 120-12io2	122		
VIO 50-06P1	71	VUE 130-12NO7	123	VUO 80-08NO1	130	VVZB 120-16io2	122		
VIO 50-12P1	71	VUI 9-06N7	120	VUO 80-12NO1	130	VVZB 135-16NO1	122		
VIO 75-06P1	71	VUI 30-12N1	120	VUO 80-14NO1	130	VVZB 170-16NO1	122		
VIO 75-12P1	71	VUM 24-05N	120	VUO 80-16NO1	130	VVZF 70-08io7	132		
VIO 100-06P1	71	VUM 25-05E	120	VUO 80-18NO1	130	VVZF 70-12io7	132		
VIO 125-12P1	71	VUM 33-05N	120	VUO 82-08NO7	130	VVZF 70-14io7	132		
VIO 130-06P1	71	VUM 85-05A	120	VUO 82-12NO7	130	VVZF 70-16io7	132		
VIO 160-12P1	71	VUO 16-08NO1	129	VUO 82-14NO7	130	VW 2x30-08io1	134		
VKF 55-08io7	127	VUO 16-12NO1	129	VUO 82-16NO7	130	VW 2x30-12io1	134		
VKF 55-12io7	127	VUO 16-14NO1	129	VUO 82-18NO7	130	VW 2x30-14io1	134		
VKF 55-14io7	127	VUO 16-16NO1	129	VUO 85-08NO7	130	VW 2x30-16io1	134		
VKF 55-16io7	127	VUO 16-18NO1	129	VUO 85-12NO7	130	VW 2x45-08io1	134		
VKI 50-06P1	72	VUO 18-12DT8	123	VUO 85-14NO7	130	VW 2x45-12io1	134		
VKI 50-12P1	72	VUO 18-14DT8	123	VUO 85-16NO7	130	VW 2x45-14io1	134		
VKI 75-06P1	72	VUO 18-16DT8	123	VUO 86-08NO7	130	VW 2x45-16io1	134		
VKM 40-06P1	94	VUO 22-08NO1	129	VUO 86-12NO7	130	VW 2x60-08io1	134		

Alphanumeric Index

► new

N 1010NC300	165	N 3476TD420	166	P 0248SG12E	170	P 0848YS04D	172	R 1124NS18K	174
N 1010NC380	165	N 3533ZC140	166	P 0248SG12F	170	P 0848YS06B	172	R 1124NS18M	174
N 1042LS120	165	N 3533ZC220	166	P 0273SC10D	170	P 0848YS06C	172	R 1124NS21K	174
N 1042LS180	165	N 3533ZD140	166	P 0273SC10E	170	P 0848YS06D	172	R 1124NS21M	174
N 1114LS120	165	N 3533ZD220	166	P 0273SC10F	170	P 1007LS12D	172	R 1127NC32R	174
N 1114LS180	165	N 3839TC300	166	P 0273SC12D	170	P 1007LS12E	172	R 1127NC32S	174
N 1132NC300	165	N 3839TC350	166	P 0273SC12E	170	P 1007LS12F	172	R 1127NC32T	174
N 1132NC320	165	N 3839TD300	166	P 0273SC12F	170			R 1127NC36R	174
N 1159NC380	165	N 3839TD350	166	P 0273SG10D	170	R		R 1127NC36S	174
N 1159NC420	165	N 4004MK020	164	P 0273SG10E	170	R 0487YS10D	173	R 1127NC36T	174
N 1265LS120	165	N 4004MK060	164	P 0273SG10F	170	R 0487YS10E	173	R 1158NS24N	174
N 1265LS150	165	N 4085ZC080	166	P 0273SG12D	170	R 0487YS10F	173	R 1158NS24P	174
N 1297NS200	165	N 4085ZC120	166	P 0273SG12E	170	R 0487YS14D	173	R 1158NS26N	174
N 1297NS260	165	N 4085ZD080	166	P 0273SG12F	170	R 0487YS14E	173	R 1158NS26P	174
N 1314NC300	165	N 4085ZD120	166	P 0295WC12D	172	R 0487YS14F	173	R 1178NS10E	174
N 1314NC360	165	N 4151FC360	167	P 0295WC12E	172	R 0577YS08C	173	R 1178NS10F	174
N 1351VC400	165	N 4151FC420	167	P 0295WC12F	172	R 0577YS08D	173	R 1178NS10G	174
N 1351VC450	165	N 4151FD360	167	P 0306SC04A	170	R 0577YS08E	173	R 1178NS14E	174
N 1351VD400	165	N 4151FD420	167	P 0306SC04B	170	R 0577YS12C	173	R 1178NS14F	174
N 1351VD450	165	N 4400TC120	167	P 0306SC04C	170	R 0577YS12D	173	R 1178NS14G	174
N 1467NS200	165	N 4400TC220	167	P 0306SC08A	170	R 0577YS12E	173	R 1211NS08D	174
N 1467NS260	165	N 4400TC280	167	P 0306SC08B	170	R 0633YS08D	173	R 1211NS08E	174
N 1479NS240	165	N 4400TD120	167	P 0306SC08C	170	R 0633YS08E	173	R 1211NS12D	174
N 1479NS300	165	N 4400TD220	167	P 0306SG04A	170	R 0633YS08F	173	R 1211NS12E	174
N 1547NS160	165	N 4400TD280	167	P 0306SG04B	170	R 0633YS12D	173	R 1271NS08D	174
N 1547NS200	165	N 4472HK160	164	P 0306SG04C	170	R 0633YS12E	173	R 1271NS08E	174
N 1588NS200	165	N 4472HK180	164	P 0306SG08A	170	R 0633YS12F	173	R 1271NS08G	174
N 1588NS260	165	N 4803FC300	167	P 0306SG08B	170	R 0717LS14G	173	R 1271NS10D	174
N 1651QK200	164	N 4803FC350	167	P 0306SG08C	170	R 0717LS14H	173	R 1271NS12E	174
N 1651QK220	164	N 4803FD300	167	P 0311SC10E	171	R 0717LS14J	173	R 1271NS12G	174
N 1661VC300	166	N 4803FD350	167	P 0311SC10F	171	R 0717LS16G	173	R 1275NS14G	174
N 1661VC360	166	N 5177FC200	167	P 0311SC10G	171	R 0717LS16H	173	R 1275NS14M	174
N 1661VD300	166	N 5177FC280	167	P 0311SC12E	171	R 0717LS16J	173	R 1275NS18L	174
N 1661VD360	166	N 5177FD200	167	P 0311SC12F	171	R 0736LS20J	173	R 1275NS18M	174
N 1712VC240	166	N 5177FD280	167	P 0311SC12G	171	R 0736LS20K	173	R 1275NS21L	174
N 1712VC300	166	N 5946FC180	167	P 0311SG10E	171	R 0736LS20L	173	R 1275NS21M	174
N 1712VD240	166	N 5946FC220	167	P 0311SG10F	171	R 0736LS20M	173	R 1279NS22J	175
N 1712VD300	166	N 5946FD180	167	P 0311SG10G	171	R 0736LS25J	173	R 1279NS22K	175
N 1718NS120	166	N 5946FD220	167	P 0311SG12E	171	R 0736LS25K	173	R 1279NS22M	175
N 1718NS180	166	NX 149MK120	164	P 0311SG12F	171	R 0736LS25L	173	R 1279NS25J	175
N 1802NS120	166	NX 149MK140	164	P 0311SG12G	171	R 0736LS25M	173	R 1279NS25K	175
N 1802NS160	166	NX 155QK020	164	P 0327WC12D	172	R 0809LS06A	173	R 1279NS25M	175
N 1806QK160	164	NX 155QK060	164	P 0327WC12E	172	R 0809LS06B	173	R 1280NS18J	175
N 1806QK180	164	NX 157HK020	164	P 0327WC12F	172	R 0809LS06C	173	R 1280NS18K	175
N 2046NS120	166	NX 157HK060	164	P 0330SC04C	171	R 0809LS10A	173	R 1280NS18M	175
N 2046NS160	166	NX 159JK020	164	P 0330SC04D	171	R 0809LS10B	173	R 1280NS21J	175
N 2083QK080	164	NX 159JK060	164	P 0330SC08C	171	R 0809LS10C	173	R 1280NS21K	175
N 2083QK140	164	NX 159JK120	164	P 0330SC08D	171	R 0830LS10D	173	R 1280NS21M	175
N 2086NS060	166	NX 159JK140	164	P 0330SG04C	171	R 0830LS10E	173	R 1280NS25J	175
N 2086NS100	166	NX 159JK160	164	P 0330SG04D	171	R 0830LS10F	173	R 1280NS25K	175
N 2172ZC400	166	NX 159JK180	164	P 0330SG08C	171	R 0830LS10G	173	R 1280NS25M	175
N 2172ZC450	166	NX 159JK200	164	P 0330SG08D	171	R 0830LS14D	173	R 1331NS10B	175
N 2172ZD400	166	NX 159JK220	164	P 0366WC04A	172	R 0830LS14E	173	R 1331NS10C	175
N 2172ZD450	166	NX 160HK120	164	P 0366WC04B	172	R 0830LS14F	173	R 1331NS10D	175
N 2293VC180	166	NX 160HK140	164	P 0366WC04C	172	R 0830LS14G	173	R 1331NS12B	175
N 2293VC220	166	NX 160HK200	164	P 0366WC08A	172	R 0878LS14K	173	R 1331NS12C	175
N 2293VD180	166	NX 160HK220	164	P 0366WC08B	172	R 0878LS14M	173	R 1331NS12D	175
N 2293VD220	166			P 0366WC08C	172	R 0878LS18K	173	R 1446NS08E	175
N 2367MK200	164	P		P 0367WC12E	172	R 0878LS18M	173	R 1446NS08F	175
N 2367MK220	164	P 0128SH10D	170	P 0367WC12F	172	R 0878LS21K	173	R 1446NS08G	175
N 2418ZC300	166	P 0128SH10E	170	P 0367WC12G	172	R 0878LS21M	173	R 1446NS12E	175
N 2418ZC360	166	P 0128SH10F	170	P 0389WC04C	172	R 0929LS08C	174	R 1446NS12F	175
N 2418ZD300	166	P 0128SH12D	170	P 0389WC04D	172	R 0929LS08D	174	R 1446NS12G	175
N 2418ZD360	166	P 0128SH12E	170	P 0389WC08C	172	R 0929LS08E	174	R 1448NS14H	175
N 2500VC120	166	P 0128SH12F	170	P 0389WC08D	172	R 0929LS12C	174	R 1448NS14J	175
N 2500VC160	166	P 0128SJ10D	170	P 0431SC04B	171	R 0929LS12D	174	R 1448NS14L	175
N 2500VD120	166	P 0128SJ10E	170	P 0431SC04C	171	R 0929LS12E	174	R 1448NS18H	175
N 2500VD160	166	P 0128SJ10F	170	P 0431SC06B	171	R 0964LS08D	174	R 1448NS18J	175
N 2543ZC240	166	P 0128SJ12D	170	P 0431SC06C	171	R 0964LS08E	174	R 1448NS18L	175
N 2543ZC300	166	P 0128SJ12E	170	P 0431SG04B	171	R 0964LS08F	174	R 1448NS20H	175
N 2543ZD240	166	P 0248SC10D	170	P 0431SG04C	171	R 0964LS12D	174	R 1448NS20J	175
N 2543ZD300	166	P 0248SC10E	170	P 0431SG06B	171	R 0964LS12E	174	R 1448NS20L	175
N 2593MK160	164	P 0248SC10F	170	P 0431SG06C	171	R 0964LS12F	174	R 2475ZC20N	175
N 2593MK180	164	P 0248SC12D	170	P 0515WC04B	172	R 0990LS04A	174	R 2475ZC28N	175
N 3012ZC200	166	P 0248SC12E	170	P 0515WC04C	172	R 0990LS04B	174	R 2475ZD20N	175
N 3012ZC260	166	P 0248SC12F	170	P 0515WC04D	172	R 0990LS04C	174	R 2475ZD28N	175
N 3012ZD200	166	P 0248SG10D	170	P 0515WC06B	172	R 0990LS08A	174	R 2619ZC18J	175
N 3012ZD260	166	P 0248SG10E	170	P 0515WC06C	172	R 0990LS08B	174	R 2619ZC18K	175
N 3476TC360	166	P 0248SG10F	170	P 0515WC06D	172	R 0990LS08C	174	R 2619ZC18L	175
N 3476TC420	166	P 0248SG12D	170	P 0848YS04B	172	R 1124NS14K	174	R 2619ZC21J	175
N 3476TD360	166			P 0848YS04C	172	R 1124NS14M	174	R 2619ZC21K	175

Alphanumeric Index

► new

R 2619ZC21L	175	R 3708FD40V	177	W 0503RC160	152	W 1411LC300	153	W 5282ZD240	155
R 2619ZC25J	175	R 3708FD40W	177	W 0503RC200	152	W 1411LC360	153	W 5282ZD300	155
R 2619ZC25K	175	R 3708FD45V	177	W 0503RC240	152	W 1520NC500	153	► W 5292TC500	155
R 2619ZC25L	175	R 3708FD45W	177	W 0503RD160	152	W 1520NC600	153	► W 5292TC560	155
R 2619ZD18J	175	RX 075FC24R	177	W 0503RD200	152	W 1524LC240	153	► W 5292TD500	155
R 2619ZD18K	175	RX 075FC24T	177	W 0503RD240	152	W 1524LC300	153	► W 5292TD560	155
R 2619ZD18L	175	RX 075FC28R	177	W 0503SC160	152	W 1608NC400	153	W 5439VC020	155
R 2619ZD21J	175	RX 075FC28T	177	W 0503SC200	152	W 1608NC500	153	W 5439VC100	155
R 2619ZD21K	175	RX 075FD24R	177	W 0503SC240	152	W 1748LC080	153	W 5439VC140	155
R 2619ZD21L	175	RX 075FD24T	177	W 0503SD160	152	W 1748LC180	153	W 5439VF020	155
R 2619ZD25J	175	RX 075FD28R	177	W 0503SD200	152	W 1748LC220	153	W 5439VF100	155
R 2619ZD25K	175	RX 075FD28T	177	W 0503SD240	152	W 1856NC400	153	W 5439VF140	155
R 2619ZD25L	175			W 0507YH360	153	W 1856NC500	153	W 5696VC020	155
R 2620ZC22J	176	S		W 0507YH450	153	W 2020NC360	153	W 5696VC100	155
R 2620ZC22K	176	S 0500KC200	178	W 0508RA040	152	W 2020NC450	153	W 5696VC140	155
R 2620ZC22L	176	S 0500KC20Y	178	W 0508RA120	152	W 2052NC300	153	W 5696VF020	155
R 2620ZC25J	176	S 0500KC25D	178	W 0508RA150	152	W 2052NC400	153	W 5696VF100	155
R 2620ZC25K	176	S 0500KC25Y	178	W 0508RB040	152	W 2054NC360	153	W 5696VF140	155
R 2620ZC25L	176	S 0700KC140	178	W 0508RB120	152	W 2054NC450	153	W 5838ZC120	155
R 2620ZD22J	176	S 0700KC14Y	178	W 0508RB150	152	W 2058LC020	153	W 5838ZC180	155
R 2620ZD22K	176	S 0700KC17D	178	W 0508SA040	152	W 2058LC100	153	W 5838ZC220	155
R 2620ZD22L	176	S 0700KC17Y	178	W 0508SA120	152	W 2058LC120	153	W 5838ZD120	155
R 2620ZD25J	176	S 1200NC200	178	W 0508SA150	152	W 2134NC300	154	W 5838ZD180	155
R 2620ZD25K	176	S 1200NC20Y	178	W 0508SB040	152	W 2134NC400	154	W 5838ZD220	155
R 2620ZD25L	176	S 1200NC25D	178	W 0508SB120	152	W 2416NC160	154	W 6262ZC120	155
R 2714ZC16H	176	S 1200NC25Y	178	W 0508SB150	152	W 2416NC200	154	W 6262ZC200	155
R 2714ZC16J	176	SXB 11987HEX	184	W 0614W C160	153	W 2416NC250	154	W 6262ZC240	155
R 2714ZC16K	176	SXB 1214FG	184	W 0614W C200	153	W 2624NC160	154	W 6262ZD120	155
R 2714ZC16L	176	SXB 1265FB	184	W 0614W C240	153	W 2624NC200	154	W 6262ZD200	155
R 2714ZC18H	176	SXB 1375B	184	W 0628RA040	152	W 2624NC250	154	W 6262ZD240	155
R 2714ZC18J	176	SXB 1645FB	184	W 0628RA120	152	W 2664NC300	154	W 6262ZC020	155
R 2714ZC18K	176	SXB 1764FG	184	W 0628RA150	152	W 2664NC400	154	W 7675ZC100	155
R 2714ZD16H	176	SXB 1920G	184	W 0628RB040	152	W 2820VC360	154	W 7675ZC140	155
R 2714ZD16J	176	SXB 2096B	184	W 0628RB120	152	W 2820VC450	154	W 7675ZD020	155
R 2714ZD16K	176	SXB 2167FB	184	W 0628RB150	152	W 2820VF360	154	W 7675ZD100	155
R 2714ZD18H	176	SXB 2324FG	184	W 0628SA040	152	W 2820VF450	154	W 7675ZD140	155
R 2714ZD18J	176	SXB 2428HEXT	184	W 0628SA120	152	W 2958NC280	154	W 8405ZC020	155
R 2714ZD18K	176	SXB 2939G	184	W 0628SA150	152	W 2958NC350	154	W 8405ZC100	155
R 3047TC24N	176	SXB 3120FG	184	W 0628SB040	152	W 3128VC300	154	W 8405ZC140	155
R 3047TC24R	176	SXB 3442B	184	W 0628SB120	152	W 3128VC400	154	W 8405ZD020	155
R 3047TC24T	176	SXB 3529HEXT	184	W 0628SB150	152	W 3128VF300	154	W 8405ZD100	155
R 3047TC28N	176	SXB 3840HEX	184	W 0642W C160	153	W 3128VF400	154	W 8405ZD140	155
R 3047TC28R	176	SXB 4264B	184	W 0642W C200	153	W 3270NC080	154		
R 3047TC28T	176	SXB 4649HEXT	184	W 0642W C240	153	W 3270NC160	154	Y	
R 3047TD24N	176	SXB 4869G	184	W 0646W C060	153	W 3270NC200	154	Y 2002KC250	179
R 3047TD24R	176	SXB 5877HEX	184	W 0646W C120	153	W 3697VC160	154	Y 5002NC250	179
R 3047TD24T	176	SXB 5993G	184	W 0646W C150	153	W 3697VC220	154	Y 8002VC450	179
R 3047TD28N	176	SXB 6240HEXT	184	W 0735RA040	152	W 3697VC280	154		
R 3047TD28R	176	SXB 868FB	184	W 0735RA120	152	W 3697VF160	154		
R 3047TD28T	176	SXB 9737HEX	184	W 0735RA150	152	W 3697VF220	154		
R 3370ZC10C	176			W 0735RB040	152	W 3697VF280	154		
R 3370ZC10D	176	T		W 0735RB120	152	W 3743ZC400	154		
R 3370ZC10E	176	T 0160NA45A	180	W 0735RB150	152	W 3743ZC500	154		
R 3370ZC12C	176	T 0240NA45E	180	W 0735SA040	152	W 3743ZD400	154		
R 3370ZC12D	176	T 0360NA25A	180	W 0735SA120	152	W 3743ZD500	154		
R 3370ZC12E	176	T 0500NA25E	180	W 0735SA150	152	► W 3841VC300	154		
R 3370ZD10C	176	T 0600T A45A	180	W 0735SB040	152	► W 3841VC340	154		
R 3370ZD10D	176	T 0800T A45E	180	W 0735SB120	152	► W 3841VF300	154		
R 3370ZD10E	176	T 0900EA45A	180	W 0735SB150	152	► W 3841VF340	154		
R 3370ZD12C	176	T 1200EA45E	180	W 0797W C040	153	W 4096ZC340	154		
R 3370ZD12D	176	T 1200T A25A	180	W 0797W C120	153	W 4096ZC450	154		
R 3370ZD12E	176	T 1500T A25E	180	W 0797W C150	153	W 4096ZD340	154		
R 3559TC16K	176	T 1800GA45A	180	W 0944W C040	153	W 4096ZD450	154		
R 3559TC16N	176	T 2400GA45E	180	W 0944W C120	153	W 4307ZC200	154		
R 3559TC16R	176	TX 115TA17A	180	W 0944W C150	153	W 4307ZC240	154		
R 3559TC16T	176	TX 116TA17E	180	W 1032LC500	153	W 4307ZC300	154		
R 3559TC20K	176	TX 167NA17E	180	W 1032LC560	153	W 4307ZD200	154		
R 3559TC20N	176	TX 168NA17A	180	W 1032LC600	153	W 4307ZD240	154		
R 3559TC20R	176			W 1074YC200	153	W 4307ZD300	154		
R 3559TC20T	176	W		W 1074YC320	153	W 4534NC020	154		
R 3559TD16K	177	W 0438RC160	152	W 1074YH200	153	W 4534NC060	154		
R 3559TD16N	177	W 0438RC200	152	W 1074YH320	153	W 5092ZC240	154		
R 3559TD16R	177	W 0438RC240	152	W 1185LC300	153	W 5092ZC280	154		
R 3559TD16T	177	W 0438RD160	152	W 1185LC360	153	W 5092ZC350	154		
R 3559TD20K	177	W 0438RD200	152	W 1185LC450	153	W 5092ZD240	154		
R 3559TD20N	177	W 0438RD240	152	W 1263YC160	153	W 5092ZD280	154		
R 3559TD20R	177	W 0438SD160	152	W 1263YC250	153	W 5092ZD350	154		
R 3559TD20T	177	W 0438SD240	152	W 1263YH160	153	W 5282ZC200	155		
R 3708FC40V	177	W 0438SD160	152	W 1263YH250	153	W 5282ZC240	155		
R 3708FC40W	177	W 0438SD200	152	W 1294NC500	153	W 5282ZC300	155		
R 3708FC45V	177	W 0438SD240	152						
R 3708FC45W	177								

IGBT and MOSFET Discrete

IXGK 60N60B2D1	(Example)
IX	IXYS
	Die technology
B	High voltage BIMOSFET
D	NPT-IGBT with SCSOA capability
E	NPT ³ IGBT
F	HiPerFET™ Power MOSFET
G	Fast IGBT
K	CoolMOS
L	IGBT with SCSOA capability
S	IGBT with SCSOA capability
T	Standard Power MOSFET
U	Trench MOSFET
	Housing type
A	TO-263 (D ² PAK)
B	PLUS 264 (TO-264 without mounting hole)
C	ISOPLUS220 (TO-220 DCB isolated)
E	ISOPLUS227 (DCB isolated miniBLOC)
F	ISOPLUS-i4 (DCB isolated)
H	TO-247
J	TO-268 (I3 PAK)
K	TO-264
L	ISOPLUS 264 (TO-264 DCB isolated)
M	TO-204 (TO-3)
N	SOT-227 B (miniBLOC)
P	TO-220
Q	TO-3P
R	ISOPLUS 247 (TO-247 DCB isolated)
T	TO-268 (D ³ PAK)
U	TO-251 (D PAK)
V	PLUS 220 (TO-220 footprint without mounting hole)
X	PLUS 247 (TO-247 without mounting hole)
50	Current rating, 50 = 50 A MOSFET = value at T _C = 25°C IGBT = value at T _C = 90°C
N	N-channel type
P	P-channel type
60	Voltage class, 60 = 600 V
xx	
	MOSFET
A	Prime R _{DS(on)} for standard MOSFET
Q	Low gate charge die
Q2	Low gate charge die, 2nd generation
P	PolarHT™ Power MOSFET
L	Linear Mode MOSFET
	IGBT
--	No letter, low V _{CE(sat)}
A	Or A2, std speed type
B	Or B2, high speed type
C	Or C2, very high speed type
xx	
D	Integrated HiPerFRED™ diode
H	Integrated SONIC-FRD™ diode
U	Integrated FRED diode
1	Antiparallel diode (free wheeling diode)
2	Diode in boost configuration
3	Diode in buck configuration

IGBT and MOSFET Modules

MII 200-12A4	(Example)
F	ISOPLUS-I4
M	Module
V	Module
C	Thyristor
D	Diode
I	IGBT with SCSOA capability
M	MOSFET
W	Three phase bridge
U	Uncontrolled 3 phase input rectifier
C	Thyristor
D	Diode
I	IGBT with SCSOA capability
K	Common cathode
M	MOSFET
O	No meaning. Reserved for future function
BW	Brake chopper and IGBT sixpack
200	Current rating 200 = 200 A
-12	Voltage class, 12 = 1200 V
A	Version A
E	NPT ³ IGBT
F	HiPerFET, MOSFET, n-channel
G	Low V _{CE(sat)} type, IGBT
K	CoolMOS
S	High speed type, IGBT
T	Standard MOSFET, n-channel or Trench IGBT
4	Version 4
6	Version CBI 1
7	Version CBI 2
8	Version CBI 3
9	E+ Package
10	High Power Module
11	High Power Module with enlarged clearance and creepage distance
T	NTC temperature sensor

CAPSULE DEVICES

W	0646	W	C	15	0
W M F E N R P K A T S H G	0646	W Y K J L Q D N M V H Z T E F G	C D F H J S T V W Y A L	15	0

(Sample)

Device Type

- Rectifier diode
- Fast/soft recovery diode
- Extra fast diode
- HP Sonic-FRD™
- Phase control thyristor
- Distributed gate thyristor
- Fast turn-off thyristor
- Medium voltage thyristor
- Asymmetric thyristor
- Press-Pack IGBT capsule
- Symmetrical Gate Turn-off thyristor
- Fast Symmetrical Gate Turn-off thyristors
- Anode Short Gate Turn-off thyristors

Device nominal current rating

Pole face Diameter

- 19mm
- 25.1mm
- 29mm (GTO Only)
- 32mm
- 34mm
- 38mm
- 44.4mm
- 47mm
- 59mm
- 63mm
- 68mm
- 73.1mm
- 75mm
- 85mm
- 99.3mm
- 125mm

Housing Type

- Standard outline
- Slim pack (63mm-73.1mm pole face only), Thick pack (75mm pole face)
- Slim pack 34mm pole face = 19.5mm height, 63mm pole face = 26mm height
- Slim pack (14mm) for 47mm pole face diode. Thick pack (26mm) for 25.1mm pole face diode)
- Slim pack (19.5mm) for 47mm pole face thyristor)
- Standard < 3kV pole face Y, L, N
- C' housing explosion rated
- D' housing explosion rated
- F' housing explosion rated
- C' housing extended explosion rating
- Round IGBT capsule
- 34mm and 47mm pole face, 26mm height GTO capsule

$$\text{Voltage grade} = V_{RRM} / V_{DRM} \div 100$$

tq code or V_{RRM} % of V_{DRM} for GTO thyristors, or for Press-Pack IGBTs

tq Code			
0	No code		
A	10	M	70
B	12	N	100
C	15	P	120
D	20	R	140
E	25	S	160
F	30	T	200
G	35	V	250
H	40	W	300
J	50	X	400
K	60	Y	500
L	65	Z	1000

V_{RRM} % of V_{DRM} for GTO's	
0	100
D	80
Y	100V

For IGBT's with.....	
A	Fully-rated diode
E	No diode

Nomenclature

WESTCODE

STUD DEVICES

W	0508	S	A	04	0	(Sample)
W						Device type
M						Rectifier diode
N						Fast/soft recovery diode
P						Phase control thyristor
	0508					Fast turn-off thyristor
						Device nominal current rating
		S				Polarity
		R				Normal
						Reverse (diode only)
			A			Package
			B			3/4" stud with lead
			C			Leaded package
			D			3/4" stud with lead
			E			Ceramic Leaded package
			F			3/4" HV ceramic stud with lug
			G			3/4" HV ceramic stud
			H			3/4" ceramic stud with lug
			J			1/2" stud with lead
			K			1/2" stud with flag
			L			M12 ceramic stud
			M			M12 stud with lug
			S			3/8" stud with lead
			T			60mm ² square base
				15		Voltage grade = $V_{RRM}/V_{DRM} \div 100$
						tq code
					0	No code
					A	10
					B	12
					C	15
					D	20
					E	25
					F	30
					G	35
					H	40
					J	50
					K	60
					L	65
					M	70
					N	100
					P	120
					R	140
					S	160
					T	200
					V	250
					W	300
					X	400
					Y	500
					Z	1000

PULSE THYRISTOR CAPSULE DEVICES

Y	2002	K	C	25	0	Device type
Y						Pulse Thyristor
	2002					Device pulse current rating
						Eg. 200×10 ²
						Pole face Diameter
		K				29mm
		N				47mm
		V				63mm
			C			Standard housing
				25		Voltage grade = $V_{RRM}/V_{DRM} \div 100$
					0	No code

Symbols and Terms

a	Acceleration	$I_{F(AV)M}$, $I_{T(AV)M}$	Maximum average forward current
BV_{CES}	Collector emitter breakdown voltage	I_{FLT}	Sink current of fault terminal
BV_{DSS}	Drain source breakdown voltage	I_{FRM}	Maximum repetitive forward current
C_{ies}, C_{iss}	Input capacitance	$I_{F(RMS)}$, $I_{T(RMS)}$	RMS forward current
C_{oes}, C_{oss}	Output capacitance	I_{FSM}, I_{TSM}	Maximum surge forward current
C_{res}, C_{rss}	Reverse transfer (Miller) capacitance	I_G, I_{GT}	Trigger gate current
d	Duty cycle	I_{GD}	Non-trigger gate current
d_A	Strike distance through air	I_{GES}	Gate emitter leakage current
di/dt, $-di/dt$	Rate of change of current	I_H	Holding current
$(di/dt)_{cr}$	Critical rate of rise of current	$I_{IN(H)}$	Signal input current (high level)
di_F/dt, $-di_F/dt$	Rate of change of forward current	$I_{IN(L)}$	Signal input current (low level)
d_S	Creep distance on surface	I_{ISOL}	RMS current for isolation test
dv/dt	Rate of rise of voltage	I_L	Latching current
$(dv/dt)_{cr}$	Critical rate of rise of voltage	I_R	Reverse current
E_{AR}	Repetitive avalanche energy	I_{RM}	Maximum reverse recovery current
E_{AS}	Non-repetitive avalanche energy	I_{RMS}	RMS current
E_{off}	Turn-off energy per pulse	I_{RRM}	Maximum repetitive reverse current
E_{on}	Turn-on energy per pulse	I_S	Continuous source current
$F_{(mounting)}$ on	Required force to mount hole-less discretes heat sink	I_{SM}	Maximum pulsed source current
g_{fs}	Forward transconductance	I^2t, ji^2dt	I^2t value for fusing
I_{AR}	Repetitive avalanche current	I_{TSM}	Maximum surge on-state current
I_{AVM}	Maximum average forward current	K_f	Characteristic factor
I_{BO}	Breakover current	K_p	Coeff. for energy per pulse E_p (material constant)
I_C (on)	Short circuit current	K_T	Temperature coefficient of V_{BO}
I_C	Collector current	L	Series stray inductance
I_{C25}	Continuous DC collector current at $T_C = 25^\circ C$	M_d	Mounting torque
I_{C90}	Continuous DC collector current at $T_C = 90^\circ C$	P_C	Collector power dissipation
I_{CES}	Collector emitter leakage current	P_D	Power dissipation
I_{CM}	Maximum pulsed collector current	P_{GAV}	Average gate power dissipation
I_D	Drain current	$P_{G(AV)M}$	Maximum average gate power dissipation
I_{DD}	Module supply current, operating mode	P_{GM}	Maximum gate power dissipation
I_{DD0}	Module supply current, standby mode	P_{RSM}	Maximum surge reverse power dissipation
$I_{D(cont)}$	Continuous drain current	P_T, P_{tot}	Total power dissipation
I_{D25}	Continuous drain current at $T_C = 25^\circ C$	Q_g	Total gate charge
I_{DAV}	Average DC output current	Q_{gc}	Gate collector (Miller) charge
$I_{D(AV)M}$	Maximum average DC output current	Q_{gd}	Gate drain (Miller) charge
I_{DM}	Maximum pulsed drain current	Q_{ge}	Gate emitter charge
I_{DRM}	Maximum repetitive off-state current	Q_{gs}	Gate source charge
$I_{D(RMS)}$	RMS output current	Q_r	Reverse recovery charge
I_{DSS}	Drain source leakage current	Q_{RM}	Reverse recovery charge (intrinsic diode)
I_F, I_T	Forward current	Q_S	Recovered charge to I_{RM}
I_{FM}	Maximum forward current	RBSOA	Reverse Bias Safe Operating Area
I_{FAV}	Average forward current	$R_{DS(on)}$	Static drain source on resistance
		RFI	Radio frequency interference (= EMI)
		R_G	Gate resistance

Symbols and Terms

R_{GE}	Gate emitter resistance	V_F	Forward voltage
r_T	Slope resistance (for power loss calculation only)	V_{FLT}	Voltage at fault terminal
R_{thCK}, R_{thCH}	Thermal resistance case to heatsink	V_{FR}	Forward recovery voltage
R_{thJA}	Thermal resistance junction to ambient	V_{GD}	Gate non-trigger voltage
R_{thJC}	Thermal resistance junction to case	V_{GE}	Gate emitter voltage
R_{thJK}, R_{thJH}	Thermal resistance junction to heatsink	V_{GE(th)}	Gate emitter threshold voltage
R_{thJS}	Thermal resistance junction to heatsink	V_{GEM}	Maximum transient collector gate voltage
R_{thJW}	Thermal resistance junction to water	V_{GES}	Maximum DC gate voltage
R_{thKA}	Thermal resistance heatsink to ambient	V_{GS}	Gate source voltage
SCSOA	Short Circuit Safe Operating Area	V_{GS(th)}	Gate threshold voltage
T_{amb}, T_A	Ambient (cooling medium) temperature	V_{GSM}	Maximum transient gate source voltage
T_C, T_{case}	Case temperature	V_{GT}	Gate trigger voltage
t_{d(off)}	Turn-off delay time	V_H	Holding voltage
t_{d(on)}	Turn-on delay time	V_{IN}	Input control voltage
t_{fi}	Current fall time (inductive load)	V_{IN(H)}	Input voltage threshold for IGBT turn-on
t_{fr}	Forward recovery time	V_{IN(L)}	Input voltage threshold for IGBT turn-off
t_{FLT}	Overcurrent or short circuit trip delay time	V_{ISOL}	Isolation voltage
t_{gd}	Gate controlled delay time	V_R	Reverse voltage
T_J, T_{VJ}	Virtual junction temperature	V_{RES}	Input voltage threshold for Reset = active
T_{JM}, T_{VJM}	Maximum virtual junction temperature	V_{RGM}	Maximum reverse gate voltage
T_K, T_H, T_S	Heatsink temperature	V_{RRM}	Maximum repetitive reverse voltage
T_L	Lead temperature	V_{RSM}	Maximum non-repetitive reverse voltage
T_{S(max)}	Maximum allowable heatsink temperature	V_{SD}	Forward voltage drop
T_{stg}	Storage temperature	V_T	Forward voltage
t_p	Pulse time	V_{T0}	Threshold voltage (for power loss calculation)
t_q	Turn-off time	Z_{thJC}	Transient thermal impedance junction to case
t_r	Current rise time	Z_{thJK}, Z_{thJH}	Transient thermal impedance junction to heatsink
t_{rr}	Reverse recovery time		
t_{rv}	Rise time of collector emitter voltage		
t_{SC}	Short circuit duration		
V_{BO}	Breakover voltage		
V_{CE}	Collector emitter voltage		
V_{CE(sat)}	Collector emitter saturation voltage		
V_{CE(sat)FLT}	Collector emitter saturation voltage to indicate fault		
V_{CEK}	Collector emitter clamp voltage on chip level		
V_{CES}	Collector emitter voltage		
V_{CGR}	Collector gate voltage		
V_{DD}	Module supply voltage		
V_{DD FLT}	Module supply voltage without fault		
V_{DGR}	Drain gate voltage		
V_{DRM}	Maximum repetitive forward blocking voltage		
V_{DS}	Drain source voltage		
V_{DSM}	Maximum non-repetitive forward blocking voltage		
V_{DSS}	Drain source breakdown voltage		
Version	Various construction designs of products		

Semiconductor Catalog, Edition 2006

© IXYS Corporation 2006
All Rights reserved

Note

As far as patents or other rights of third parties are concerned, liability is only assumed for components per se, not for applications, processes and circuits implemented with components or assemblies. The information describes the type of component and shall not be considered as assured characteristics. Stress above one or more of the limiting values may cause permanent damage to the device. These are stress ratings only and operation of the device at these or at any other conditions above those given in the characteristics sections of the specification is not implied. Exposure to limiting values for extended periods may affect device reliability. Terms of delivery and rights to change design or specifications are reserved. Changes have been made to earlier published specifications. The data herein supersedes all previously published informations.

Life support applications

IXYS products used in life support appliances, devices, or systems where malfunction of these products can reasonably be expected to result in personal injury must be expressly authorized for such purposes.

Patents and Intellectual Property

IXYS products, listed in the Selector Guide, are covered in part or whole by the following patents.

Micronix	Clare	IXYS Corp.	
US 6,594,606	111118	US 4,483,810	US 6,147,393
US 6,828,850	141039	US 4,636,580	US 6,162,665
US 6,943,500	1175115	US 4,670,771	US 6,259,123
US 6,943,761	7812789	US 4,731,644	US 6,306,728
US 6,963,321	US 5,946,394	US 4,766,481	US 6,323,090
US 6,965,360	US 6,037,602	US 4,835,592	US 6,404,065
US 6,972,742	US 6,226,331 B1	US 4,860,072	US 6,507,239
US 6,995,737	DE 2818466	US 4,876,517	US 6,534,343
	EPO 48146	US 4,881,106	US 6,583,505
		US 4,890,013	US 6,583,665
IXYS RF		US 4,912,619	US 6,642,551
US 4,891,686		US 4,931,844	US 6,683,344
US 5,640,045		US 4,970,576	US 6,670,216
	Westcode	US 4,972,043	US 6,710,463
	DE 4306871	US 5,017,508	US 6,727,585
	EP 1168446	US 5,034,796	US 6,731,002
	EP 0923127	US 5,049,961	US 7,005,734
	GB 2363904	US 5,063,307	US 7,005,734 B2
	GB 2332092	US 5,159,425	US D420 983
	GB 2311412	US 5,166,771	
	GB 2264662	US 5,168,076	
	IN 181278	US 5,172,211	
	JP 11238826	US 5,187,117	
	JP 3334813	US 5,191,279	
	US 6678163	US 5,237,481	
	US 6303974	US 5,340,774	
	US 6147382	US 5,381,025	
	US 5380598	US 5,348,897	
		US 5,359,226	
		US 5,384,744	
		US 5,412,227	
		US 5,424,709	
		US 5,477,074	
		US 5,483,104	
		US 5,486,715	
		US 5,493,530	
		US 5,500,616	
		US 5,543,335	
		US 5,557,575	
		US 5,596,466	
		US 5,620,919	
		US 5,629,552	
		US 5,640,045	
		US 5,654,896	
		US 5,656,861	
		US 5,698,454	
		US 5,699,232	
		US 5,731,729	
		US 5,801,419	
		US 5,851,857	
		US 5,895,961	
		US 5,904,544	
		US 6,091,086	
		US 6,107,674	

Analog & Mixed Signal ASIC Capabilities

Since our founding in 1983, Micronix has supplied hundreds of high performance mixed analog-digital integrated circuits for the commercial, industrial and military markets.

Using our own Intellectual Property (IP) combined with third party IP, we can work with you to develop an ASSP that meets the needs of your particular industry or we can perform a complete turnkey solution of a high volume, proprietary mixed-signal ASIC specifically for your product.

As a subsidiary of IXYS, we have access to an in-house High Voltage Silicon On Insulator foundry and multi-chip module assembly line. Additionally, we have developed strategic alliances with other select, highly capitalized wafer foundries

and assembly houses. This unique capability enables us to apply the optimum mix of circuit topology and process to each application.

Experience has taught us that the most successful programs are those in which our customer's engineering staff play a major role in defining the circuit requirements. This close working relationship maximizes the benefits derived from a custom integrated circuit.

We believe that in today's complex business and technical relationships, trust and loyalty are as relevant as they ever have been. These simple virtues have provided the foundation of our growth, and we are committed to bringing them into each new business relationship.

Mixed Signal Design Flow

- **Turnkey:**
Micronix develops and manufactures a device that meets your product specifications.
- **Collaborative:**
Your digital design is incorporated via VHDL (or other high level language) or GDSII with Micronix analog functions to develop and manufacture a device that meets your product specifications.

General Performance Parameters

- Supply Voltages from 0.5 V to 550 V
- Operating Frequencies from DC to 150MHz

Foundry Partners

- **US:** AMI, X-Fab
- **Europe:** AMI, X-Fab, Zarlink
- **Asia:** Dongbu, Samsung, UMC

Process Technologies

- CMOS Mixed Signal w/High Voltage
- Bipolar
- BiCMOS
- SOI BCDMOS High Voltage

Packaging

- Through-Hole
DIP, PGA
- Surface Mount
BGA
CLCC, PLCC
QFN, QFP
SOIC
- Multi-Chip Module
- TCP/COF (Tape Carrier Packaging, Chip On Flex)
70mm
Super 48mm
Super 35mm
- Tested Die (option = bumped)
Waffle Pack
Wafer (Inked or wafer map)
- Tape & Reel

Screening

- Mil-Std-883 Class B
- Custom

Quality

- Mil-I-45208 Certified
- ISO 9001:2000 Certified

Features

- ✓ CMOS Technology
- ✓ ±15 Volt Output Driver Supply Voltage
- ✓ Drives Segment or Active Matrix Displays
- ✓ 4 Level Gray Scale
- ✓ 20 MHz Clock Frequency
- ✓ Bi-Directional Data Transfer
- ✓ Selectable Register Length
- ✓ 2.7V to 5.5V Logic Supply Voltage
- ✓ Cascadable

Ordering Information

Part No.	Description
16001	Gold Bumped Die / Waffle Pack
16026	Gold Bumped Die / Wafer Form
16035-00	48mm Super Wide Tape Carrier

General Description

The MX834 is a selectable 240, 256, or 268 bit long 2-bit wide serial-input parallel-output digital shift register with level conversion on each parallel output which converts the 2 digital bits into positive, VSS, or negative analog output voltages. An 8-bit input bus simultaneously inputs 4 groups of 2 bits each.

The MX834 consists of a selectable length Bi-Directional Input Register, Transfer Latch, and 268 bit Level Shifter / Output Driver. Each „OUT“ pin is switched to one of [VSS, VPOS, VNEG] according to the D0...D7 logic levels clocked into the MX834, modified by the OE pin.

The MX834 is designed to operate over a temperature range of -40°C to +85°C, and is available as Gold Bumped Die in Waffle Pack, Gold Bumped in Wafer Form, and 48mm Tape Carrier Package.

Block Diagram

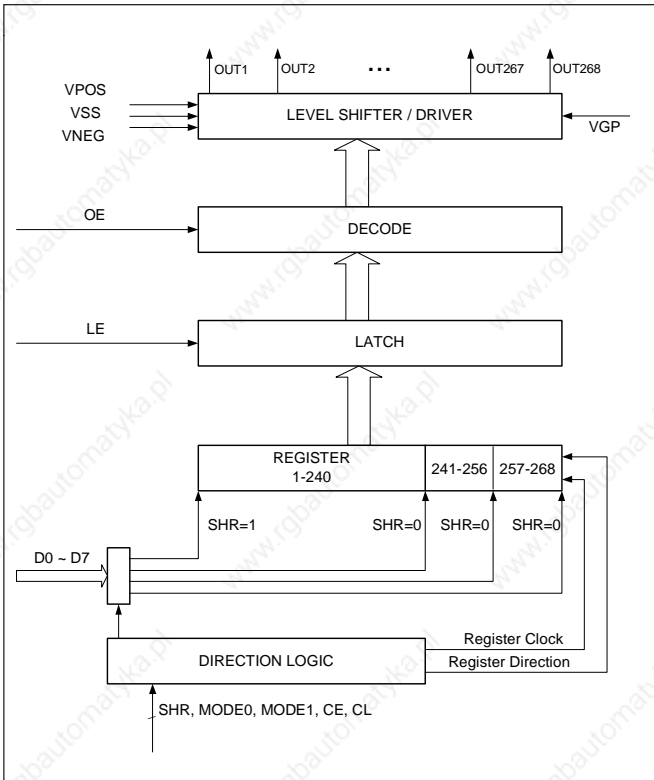

MX860

±15V E Ink Source Driver

Features

- √ CMOS Technology
- √ ±15 Volt Output Driver Supply Voltage
- √ Drives Segment or Active Matrix Displays
- √ 4 Level Gray Scale
- √ 25 MHz Clock Frequency
- √ Bi-Directional Data Transfer
- √ Selectable Register Length
- √ 2.7 V to 5.5 V Logic Supply Voltage
- √ Cascadable

General Description

The MX860 is a selectable 240, 256, or 268 bit long 2-bit wide serial-input parallel-output digital shift register with level conversion on each parallel output which converts the 2 digital bits into VPOS, VSS, or VNEG analog output voltages. An 8-bit input bus simultaneously inputs 4 groups of 2 bits each. The MX860 consists of a selectable length Bi-Directional Input Register, Transfer Latch, and 268 bit Level Shifter / Output Driver. Each „OUT“ pin is switched to one of [VSS, VPOS, VNEG] according to the D0...D7 logic levels clocked into the MX860, modified by the OE pin. The MX860 is designed to operate over a temperature range of -40°C to +85°C, and is available as Gold Bumped Die in Waffle Pack, Gold Bumped in Wafer Form, 48mm Tape Carrier Package, and 324 ball BGA package.

Ordering Information

Part No.	Description
086001	Gold Bumped Die / Waffle Pack
086002	Gold Bumped Die / Wafer Form
086060-00	48mm Super Wide Tape Carrier
086070-00	15mm X 15mm BGA

Block Diagram

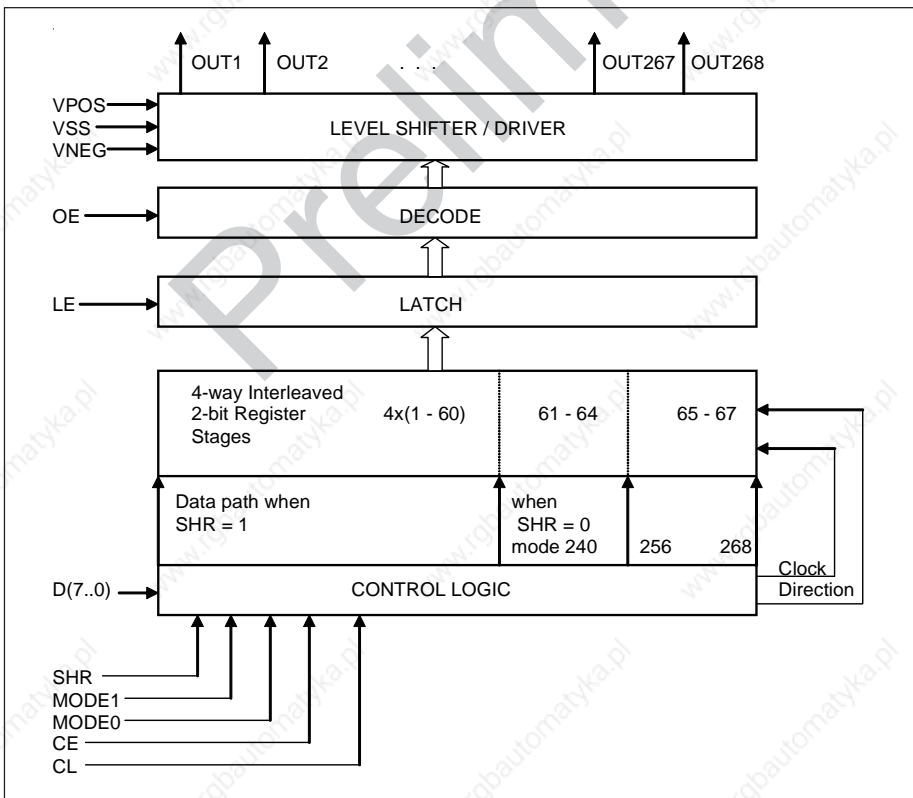

MXEI1480

±15V E Ink Source Driver

Features

- √ CMOS Technology
- √ ±15 Volt Output Driver Supply Voltage
- √ Drives Segment or Active Matrix Displays
- √ 4 Level Gray Scale
- √ 25MHz Clock Frequency
- √ Bi-Directional Data Transfer
- √ Selectable Register Length
- √ 2.7 V to 5.5 V Logic Supply Voltage
- √ Cascadable

General Description

The MXEI1480 is a selectable 400, or 480 bit long 2-bit wide serial-input parallel-output digital shift register with level conversion on each parallel output which converts the 2 digital bits into VPOS, VSS, or VNEG analog output voltages. An 8-bit input bus simultaneously inputs 4 groups of 2 bits each.

The MXEI1480 consists of a selectable length Bi-Directional Input Register, Transfer Latch, and 480 bit Level Shifter / Output Driver. Each „OUT“ pin is switched to one of [VSS, VPOS, VNEG] according to the D0...D7 logic levels clocked into the MXEI1480, modified by the OE pin.

The MXEI1480 is designed to operate over a temperature range of -40°C to +85°C, and is available as Gold Bumped Die in Waffle Pack, and Gold Bumped in Wafer Form.

Ordering Information

Part No.	Description
E1148001-00	Gold Bumped Die / Waffle Pack
E1148002-00	Gold Bumped Die / Wafer Form

Block Diagram

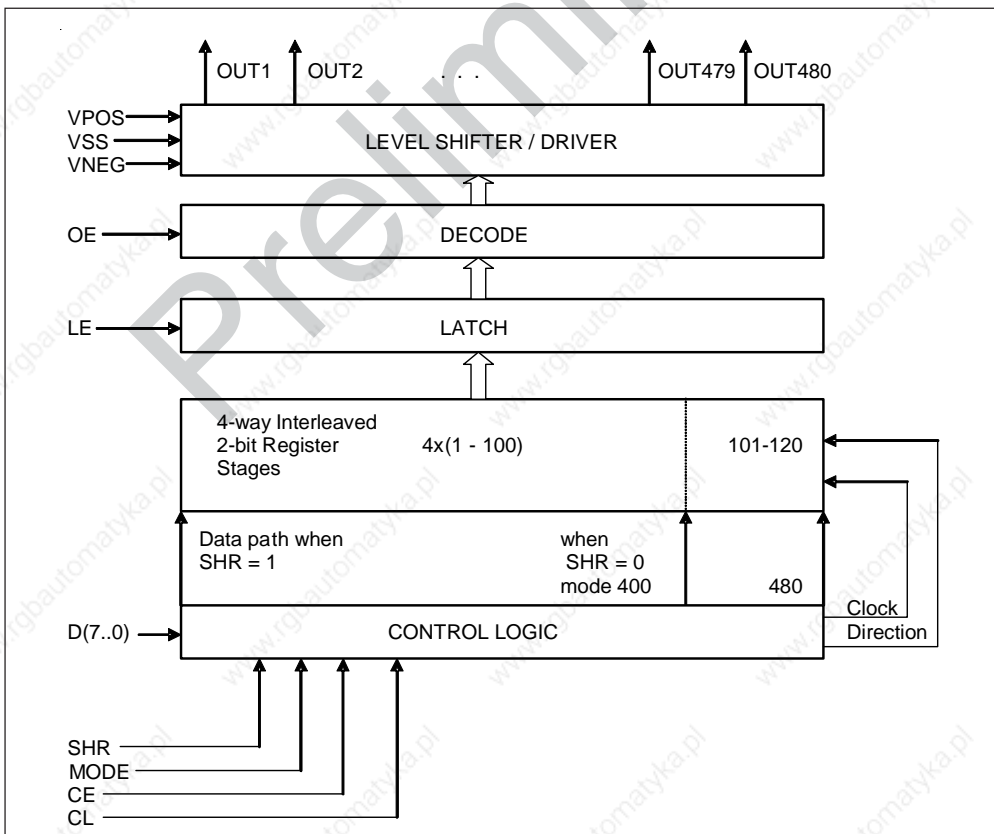

MXEI2240

240 Output E Ink Gate Driver

Features

- ✓ CMOS Technology
- ✓ Drives Segment or Active Matrix Displays
- ✓ 16 to 57.5 Volt Output Drive
- ✓ Selectable Output Shift Direction and Polarity
- ✓ 3 Output Switching Modes
- ✓ Cascadable (4 Maximum)

Ordering Information

Part No.	Description
EI224001-00	Gold Bumped Die / Waffle Pack
EI224002-00	Gold Bumped Die / Wafer Form

General Description

The MXEI2240 is a 240 bit serial shift register, level translator, and high voltage buffered driver. The shift register is 'seeded' by the CE1, CE2, R/L, SPV, and CKV inputs.

The output pulse pattern is selected with the MODE1 and MODE2 inputs. A one pulse, continuous two pulse, jumping two pulse, or no pulse pattern can be generated. Pulse polarity is selected with the WALK0 input.

The register output bits are amplified rail-rail from V_{EE} to V_{DD} , and the output strength of the buffer drivers is modulated by the Vbias generator. This allows the OGN outputs to be continuously optimized for peak performance while minimizing transients over a wide operating range.

The MXEI2240 is designed to operate over a temperature range of -40°C to $+85^{\circ}\text{C}$, and is available as Gold Bumped Die in Waffle Pack, and Gold Bumped Die in Wafer Form.

Block Diagram

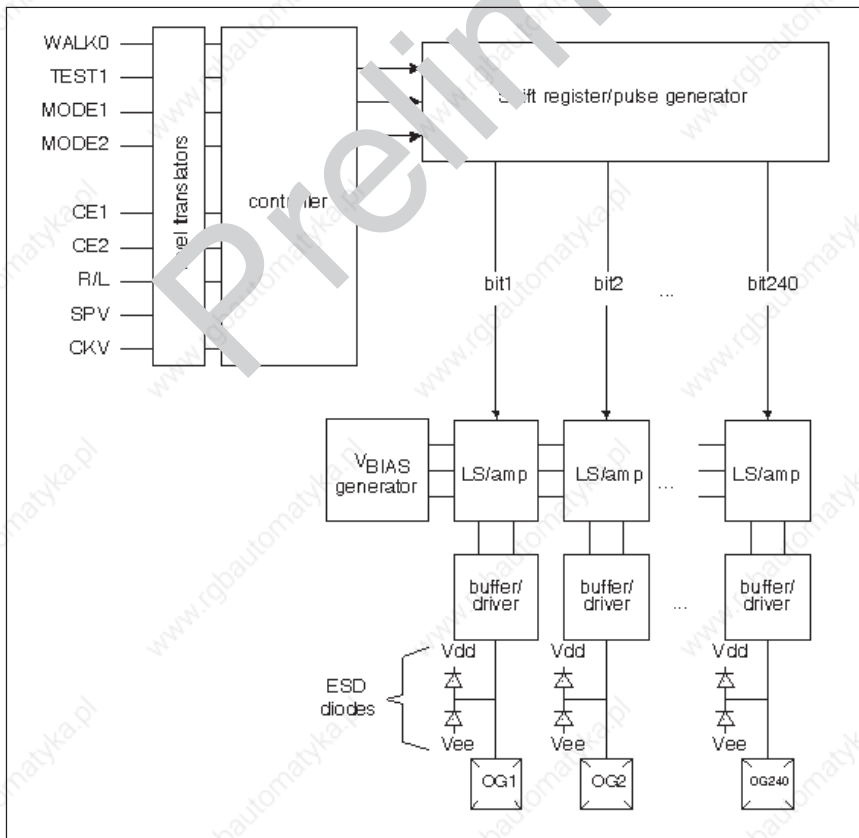

MX841

White LED Step-Up Converter

Features

- ✓ 1.1V to 5.5V Input Range
- ✓ 2 Amp Peak Switch Current
- ✓ High Efficiency > 80%
- ✓ 20 V Maximum Output with Over-Voltage Protection
- ✓ LED Intensity Control
- ✓ 1.0 MHz Fixed Frequency Switching
- ✓ 8 Lead SOIC Package

Applications

- White LED Display Backlighting
 - Low Voltage: Mobile Phones, PDA's, MP3 Players, Digital Cameras
 - High Drive Current: Vehicle Instrumentation Panels

Ordering Information

Part No.	Description	Qty
17000-00TU	SOIC-8 Standard Tube	100
17000-00TR	SOIC-8 Standard T&R	2500
17043-00TU	SOIC-8 Exposed Pad Tube	100
17043-00TR	SOIC-8 Exposed Pad T&R	2500

General Description

The MX841 is a fixed frequency, constant current source step-up DC/DC converter. The output current is directly regulated making the MX841 ideal for driving series connected white light emitting diodes (LED's) in backlight applications. The MX841 powers up to 3 series white LED's at 1.1 V, and 20 series/parallel white LED's at 5.0 V. The MX841 features a 1.0 MHz switching frequency to accommodate the use of small capacitors and a small inductor necessary in size sensitive portable applications.

Light intensity and shutdown are conveniently controlled by a single analog voltage. Power efficiency and battery life are extended through the use of a high voltage, low $R_{DS(ON)}$ N-channel MOSFET switch. The MX841 is designed to operate over a temperature range of -40°C to $+85^{\circ}\text{C}$, and is available in an SOIC-8 Package, with or without an Exposed Pad in Tube or on Tape and Reel. (Alternate package types available upon request).

Functional Block Diagram

Typical Application

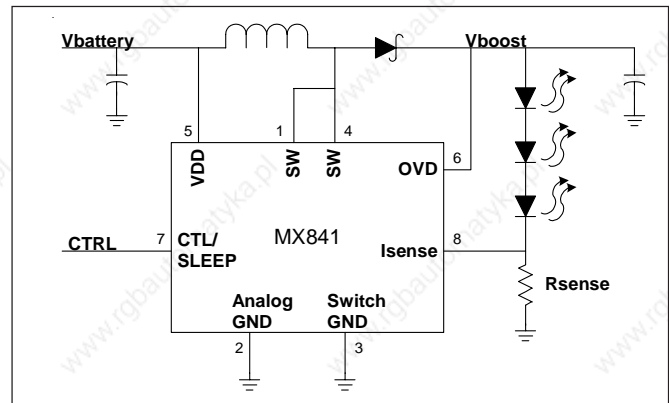
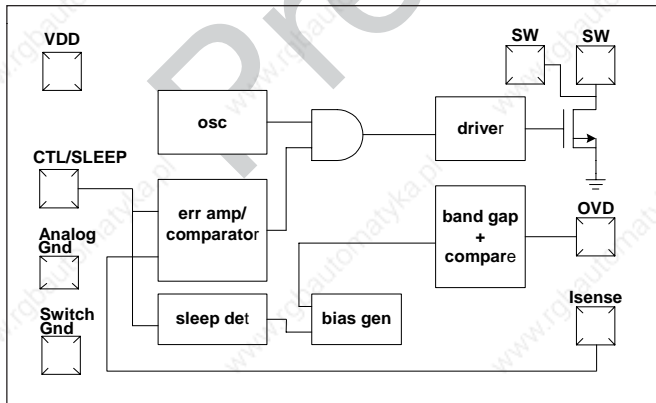

MX865

White LED Step-Up Converter with Log Dimming

Features

- ✓ 2.4V to 5.5V Input Range
- ✓ 2 Amp Peak Switch Current
- ✓ High Efficiency > 80%
- ✓ 20V Maximum Output with Over-Voltage Protection
- ✓ LED Intensity Control
- ✓ 1.0 MHz Fixed Frequency Switching
- ✓ 16 Lead SOIC Package

Applications

- White LED Display Backlighting
 - Low Voltage: Mobile Phones, PDA's, MP3 Players, Digital Cameras
 - High Drive Current: Instrumentation Panels

Ordering Information

Part No.	Description	Qty
086500-00	SOIC-16 Exposed Pad Tube	
086528-00	SOIC-16 Exposed Pad T&R	

General Description

The MX865 is a fixed frequency, constant current source step-up DC/DC converter. The output current is directly regulated making the MX865 ideal for driving series connected white light emitting diodes (LED's) in backlight applications. The MX865 powers up to 3 series white LED's at 2.4 V, and 20 series/parallel white LED's at 5.0 V.

The MX865 features a 1.0MHz switching frequency to accommodate the use of small capacitors and a small inductor necessary in size sensitive portable applications. Light intensity is logarithmically controlled through an external potentiometer or DAC. Power efficiency and battery life are extended through the use of a high voltage, low $R_{DS(ON)}$ N-channel MOSFET switch.

The MX865 is designed to operate over a temperature range of -40°C to $+85^{\circ}\text{C}$, and is available in an SOIC-16 Package, with or without an Exposed Pad in Tube or on Tape and Reel. (Alternate package types available upon request).

Functional Block Diagram

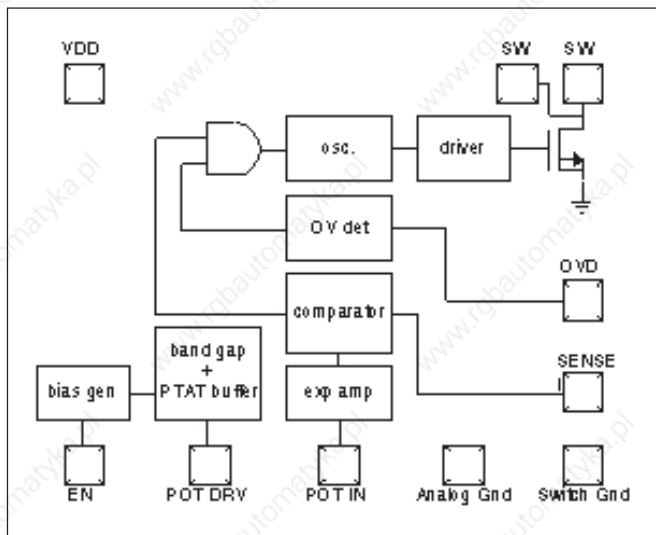

Typical Application

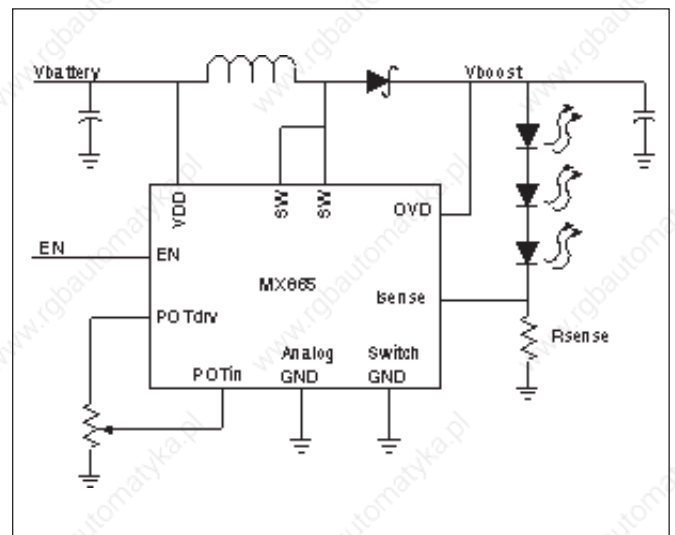

Features

- ✓ Highly Integrated Solution that includes:
Optimized Flyback Boost Converter Controller, IGBT Driver, and 100mA LED Torch Driver
- ✓ Small Size (3mm x 5mm MLPD-16)
- ✓ High Efficiency
- ✓ 3.0 to 5.5 Volt Battery Operation
- ✓ 1.65 to 5.5 Volt Digital Interface Operation
- ✓ Low Shut Down Current: 0.1iA
- ✓ SPI and I²C Bus Compatibility
- ✓ Programmable Average Battery Current:
(50mA – 300mA)
- ✓ Programmable Output Voltage: (300V - 330V)

Applications

- Camera Cell Phones, Digital Still Cameras, and Optical Film Cameras

Ordering Information

Part No.	Package Description
088900-00	3mm X 5mm MLPD-16

General Description

The MX881 offers a highly integrated Xenon Flash controller, providing an ideal solution for small form factor flash and torch lighting applications. The MX881 integrates a user programmable Controller, IGBT Driver, and 100mA LED Torch Driver to significantly reduce component count, solution size, and design complexity.

The Boost Control Logic manages the peak primary current and off time to optimize charge time and control average battery current.

The Charge Cycle Control starts the charge cycle on a low to high transition of the CHARGE input. Then detects when the output voltage has reached the desired voltage and stops the Boost Control Logic, while asserting the DONE output signal.

The SPI/I²C serial interface adds the flexibility of 6 programmable average battery currents and 4 programmable high voltage output levels for the flash function.

Typical Application

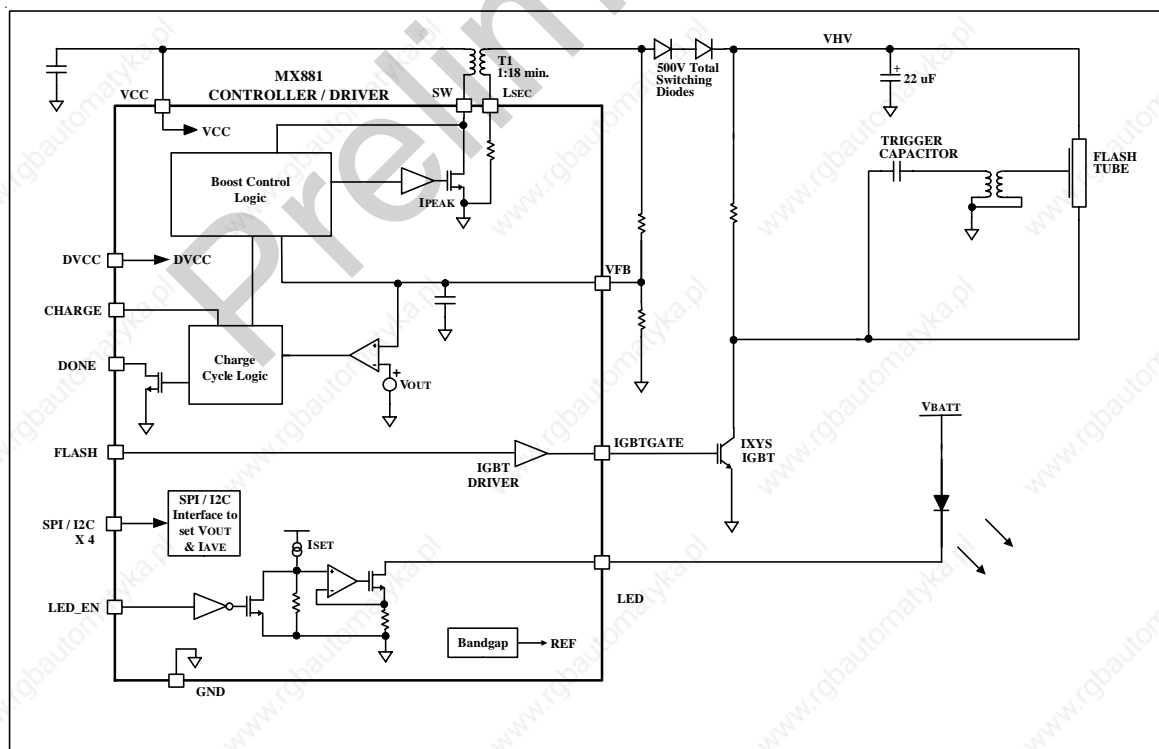

MXHV9910

Off-Line High Brightness LED Driver

Features

- ✓ 8 V to 450 V Input Voltage Range
- ✓ High Efficiency
- ✓ Drives from 1 to Hundreds of LEDs in Series/Parallel Combinations
- ✓ Regulated LED Drive Current
- ✓ Linear or PWM Brightness Control
- ✓ Resistor Programmable Oscillator Frequency
- ✓ SOIC-8 RoHS Package

Applications

- Flat Panel Display RGB Backlighting
- Signage and Decorative LED Lighting
- DC/DC or AC/DC LED Driver Applications

Ordering Information

Part No.	Description	Qty
HV991000-00	SOIC-8	100
HV991041-00	SOIC-8 Tape & Reel	2500

General Description

The MXHV9910 is a high-efficiency off-line LED driver. Manufactured using a dialectically isolated process the MXHV9910 can operate from 8 V to 450 V. This highly versatile input operating voltage enables a broad range of High Brightness (HB) LED applications. The MXHV9910 drives an external MOSFET at a fixed oscillator frequency set by an external resistor. Peak constant current to an LED string is maintained by modulating the MOSFET GATE signal on and off through the external current sense resistor connected to the CS input. Dimming of and LED string is controlled by adjusting the duty cycle of the PWM input, or applying a control voltage from 0 to 250 mV to the LED input.

Functional Block Diagram and Typical Application

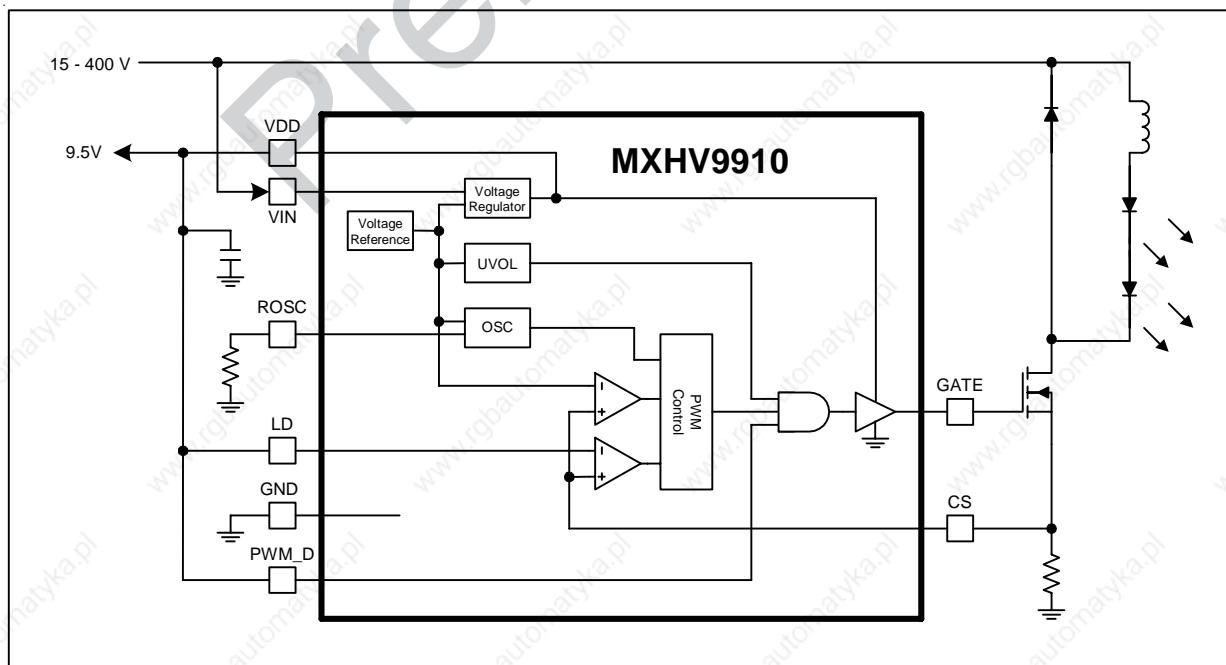

MX887D / MX887P

μ Power Hall-Effect Switch

Features

- ✓ μ Power Operation (15 μ W typical at 25°C)
- ✓ Omni polar (switches with N or S pole)
- ✓ 2.5 to 5.5 Volt Operation
- ✓ Simple Digital Output Interfacing
Open Drain (MX887D) or Active Pull-up (MX887P)
- ✓ Ultra Low Offset Cancelling Amplifiers Provide Sensitive, Accurate, Stable Switching Points and Immunity to Mechanical Stress
- ✓ Solid State Circuitry
- ✓ Operating Temperature Range: -40°C to +85°C
- ✓ SOT-23 Package Lead-Free

General Description

The MX887 integrated Hall-Effect switch is designed to address the requirements of low-power portable devices, such as cellular flip-phones, with battery operating voltages from 2.5 V to 5.5 V. On-chip power management circuitry reduces the effective average current to just 5 μ A at 3.0 V_{SUPPLY}.

The switch output will turn „on“ when either a north or south magnetic pole is applied. The absence of a magnetic field will turn the switch into a high impedance „off“ state. Mimicking the behavior of a traditional reed switch, together with the advantages of high integration and solid state reliability, makes the MX887 is an ideal replacement in low-power portable device applications.

Applications

- Cellular Flip-Phones
- High Reliability Reed Switch Replacement

Ordering Information

Part No.	Description
088741-00	SOT-12 Tape & Reel

Functional Block Diagram

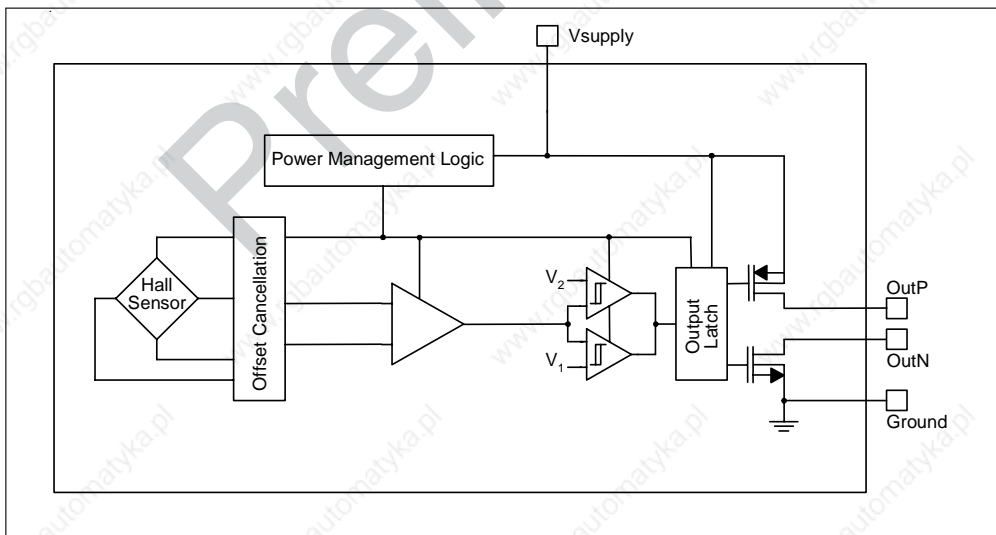

MX840A / MX840B

Hex Level Shifter and Output Driver

Features

- √ CMOS Technology
- √ TTL/CMOS compatible inputs
- √ Low switching noise
- √ < 5 nS typical true / complement output skew
- √ < 3.5 nS typical output rise and fall times
- √ Up to 11 V output voltage
- √ Output high voltage programmable via V_{OPT}
- √ Output low voltage programmable via V_{EE}

Applications

- Digital control of analog circuits
- Level shifting and amplification
- Circuit applications requiring complementary signal generation with low skew
- Bias control for a PIN diode drivers in a microwave switch

General Description

The MX840A and MX840B are high speed six channel level shifters with complimentary output drivers. The MX840A features a 3.3 V V_{CC} positive supply, and the MX840B features a 5.0 V V_{CC} positive supply.

The input buffers accept digital TTL or CMOS level signals, amplifies them to the V_{CC} and GND supply rails, and generates complementary outputs. The translator level shifts these output signals by amplifying them to the V_{CC} and V_{EE} supply rails.

The output drivers then buffer the signals to V_{OPT} and V_{EE} . V_{OPT} may be set within the range of V_{CC} and GND. The output drivers also adjust the complimentary signals for minimized skew error.

The MX840A and MX840B are designed to operate over a temperature range of -40°C to +85°C, and are available as die in wafer form, die in waffle pack, 24 lead SOIC package, and SOIC on Tape and Reel.

Ordering Information – MX840B

Part No.	Description
19902	MX840B Die / Wafer Form
19901	MX840B Die / Waffle Pack
19900-00	MX840B 24 Lead SOIC
19941-00	MX840B SOIC on Tape & Reel

Ordering Information – MX840A

Part No.	Description
19602	MX840A Die / Wafer Form
19601	MX840A Die / Waffle Pack
19600-00	MX840A 24 Lead SOIC
19641-00	MX840A SOIC on Tape & Reel

Functional Block Diagram

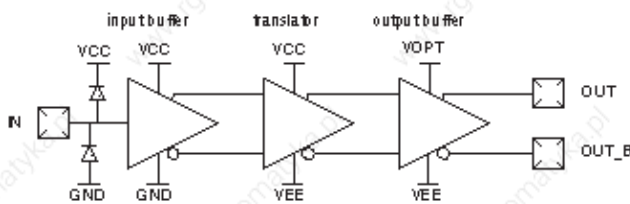

24 Lead SOIC Configuration

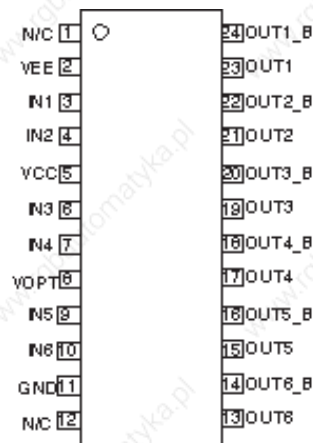

MX844

Multi-Function A/D Converter

Features

- ✓ Programmable gain differential amplifier (± 10 mV, ± 25 mV, ± 50 mV, ± 250 mV ranges)
- ✓ 4 channel differential input multiplexer (3 input channels plus ground)
- ✓ 12-bit dual-slope ADC, ± 2047 maximum count
- ✓ SYNC pin for optional ADC external synchronization
- ✓ Selectable clock dividers for ADC conversion rate
- ✓ Data ready status bit and active-low output pin DRDY
- ✓ Programmable digital comparator for threshold detection, with active-low output pin CMP
- ✓ Fine calibration of full scale range using VTRIM pin
- ✓ Internal temperature sensor with 0.2°C resolution
- ✓ Supply voltage range of 4.5 to 5.5 V, or 6 to 40 V using internal voltage regulator, with internal MOSFET or external PNP transistor pass element
- ✓ TTL compatible inputs allow 3.3V interface
- ✓ Asynchronous serial data output pin AOUT, standard baud rates
- ✓ Crystal/resonator oscillator or external clock input, range from 100 KHz to 20 MHz

General Description

- Voltage, Current & Temperature Measurement
- 12 Bit Resolution, 3 1/2 Digits Plus Sign
- Internal Voltage Reference
- Optimized To Measure Small Voltages Near Ground
- 4-Wire Standard Synchronous Serial I/O Interface Or Scan Mode Controlled By Serial EEPROM
- Asynchronous Serial Talk-Only Data Output
- Device Supply Voltage up to 40 V
- Compatible with 3.3 V and 5 V Microcontrollers
- Bi-directional Current Sensing
- Operating Temperature Range: -40°C to $+85^\circ\text{C}$
- QFN-28 RoHS Package

Ordering Information

Part No.	Description	Qty
084400-00	QFN-28 Tube	73
084441-00	QFN-28 Tape & Reel	2500

Block diagram

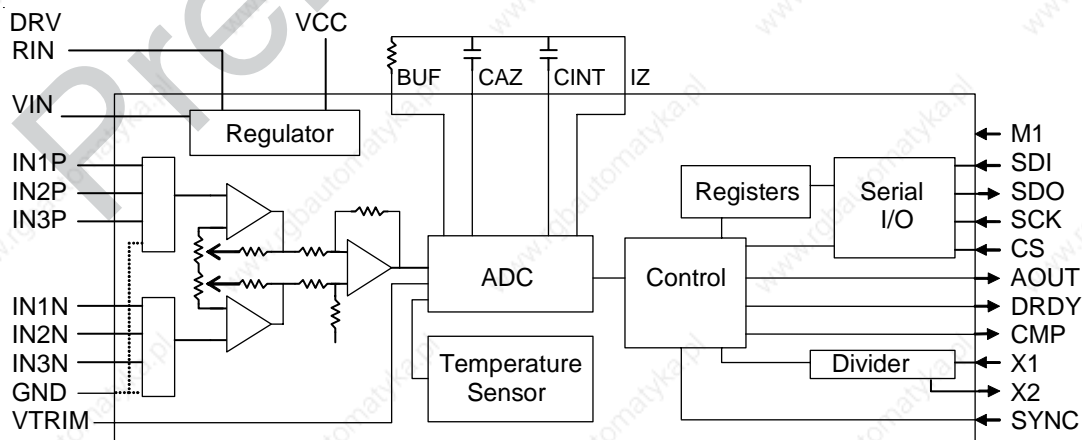

Typical Application

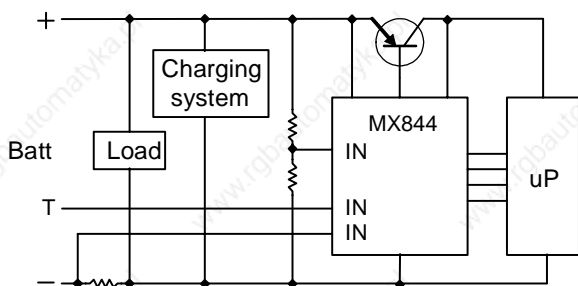

Battery charge/discharge current, voltage, temperature

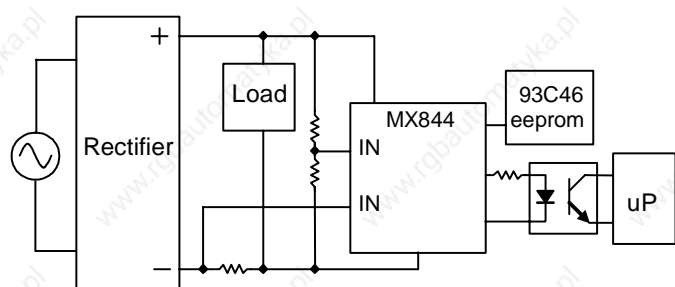

Isolated voltage, current, and temperature sensing

MX877

8-Channel 60V Driver with 3 Wire Interface

Features

- ✓ 8 Outputs Rated at 60V, 80mA
- ✓ Push-Pull Driver Configuration
- ✓ 6 V to 60 V Driver Supply Range
- ✓ 2.7 V to 5.5 V Logic Supply Range
- ✓ 3 Wire Serial Interface plus Chip Select
- ✓ Captures Serial & Parallel Input Data
- ✓ Outputs can be paralleled
- ✓ 28 Lead QFN Package

Ordering Information

Part No.	Description	Qty
087700-00	QFN-28	73
087741-00	QFN-28 Tape & Reel	2500

General Description

The MX877 is an 8 channel high voltage switch with 8-bit parallel or serial input control. The MX877 connects directly to a microprocessor through a standard 3 wire serial interface. The push-pull output configuration can drive up to 60 Volts at 80 mA. Outputs can be paralleled for increased drive current up to a device total of 400 mA sink or source.

The MX877 is designed to operate over a temperature range of -40°C to +85°C, and is available in a QFN-28 Package.

Functional Block Diagram

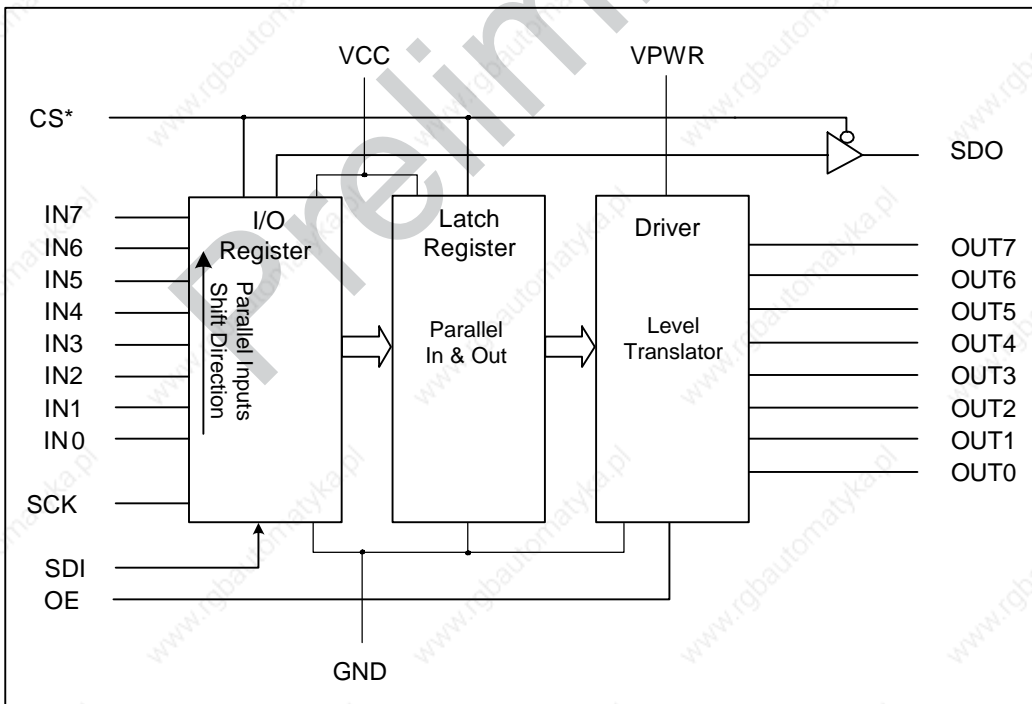

MX878

8-Channel 60V Driver with 3 Wire Interface

Features

- ✓ 8 Outputs Rated at 60V, 200mA
- ✓ Open Drain Pull-Down Driver Configuration
- ✓ 6 V to 60 V Driver Supply Range
- ✓ 2.7 V to 5.5 V Logic Supply Range
- ✓ 3 Wire Serial Interface plus Chip Select
- ✓ Captures Serial & Parallel Input Data
- ✓ Outputs can be paralleled
- ✓ 28 Lead QFN Package

General Description

The MX878 is an 8 channel high voltage switch with 8-bit parallel or serial input control. The MX878 connects directly to a microprocessor through a standard 3 wire serial interface. The open drain pull-down output configuration can drive up to 60 volts at 200 mA. Outputs can be paralleled for increased drive current up to a device total of 1000 mA sink.

The MX878 is designed to operate over a temperature range of -40°C to +85°C, and is available in a QFN-28 Package.

Ordering Information

Part No.	Description	Qty
087800-00	QFN-28	73
087841-00	QFN-28 Tape & Reel	2500

Functional Block Diagram

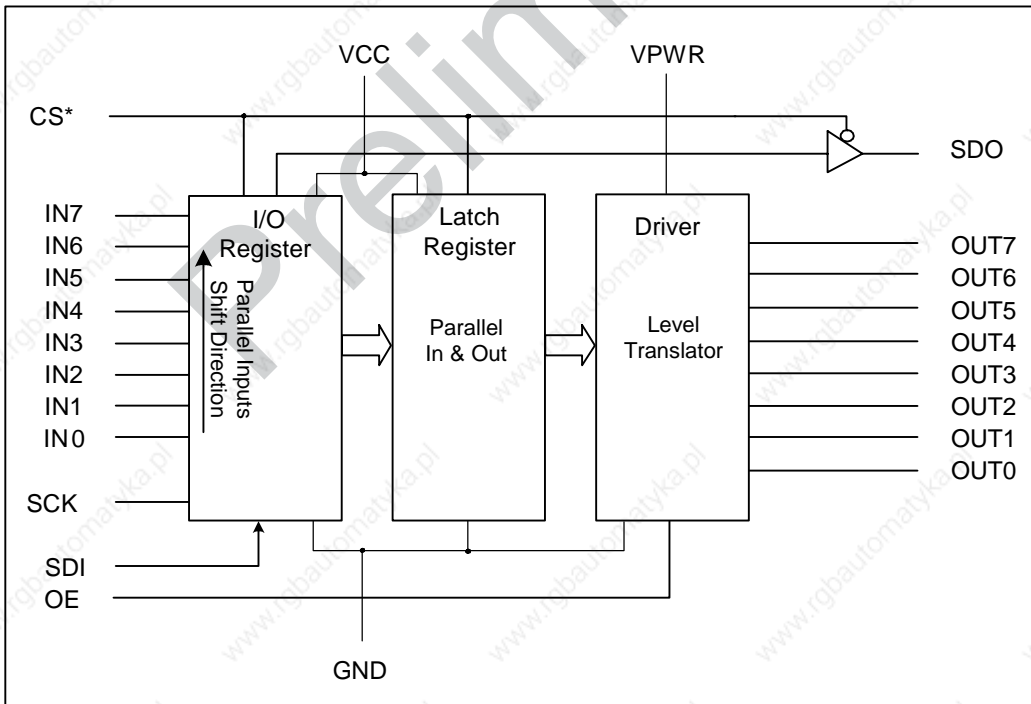

MX879

8-Channel 60V Driver with 3 Wire Interface

Features

- ✓ 8 Outputs Rated at 60V, 120mA
- ✓ Open Drain Pull-Up Driver Configuration
- ✓ 6V to 60V Driver Supply Range
- ✓ 2.7V to 5.5V Logic Supply Range
- ✓ 3 Wire Serial Interface plus Chip Select
- ✓ Captures Serial & Parallel Input Data
- ✓ Outputs can be paralleled
- ✓ 28 Lead QFN Package

Ordering Information

Part No.	Description	Qty
087900-00	QFN-28	73
087941-00	QFN-28 Tape & Reel	2500

General Description

The MX879 is an 8 channel high voltage switch with 8-bit parallel or serial input control. The MX879 connects directly to a microprocessor through a standard 3 wire serial interface. The open drain pull-up output configuration can drive up to 60 volts at 120 mA. Outputs can be paralleled for increased drive current up to a device total of 600 mA source.

The MX879 is designed to operate over a temperature range of -40°C to +85°C, and is available in a QFN-28 Package.

Functional Block Diagram

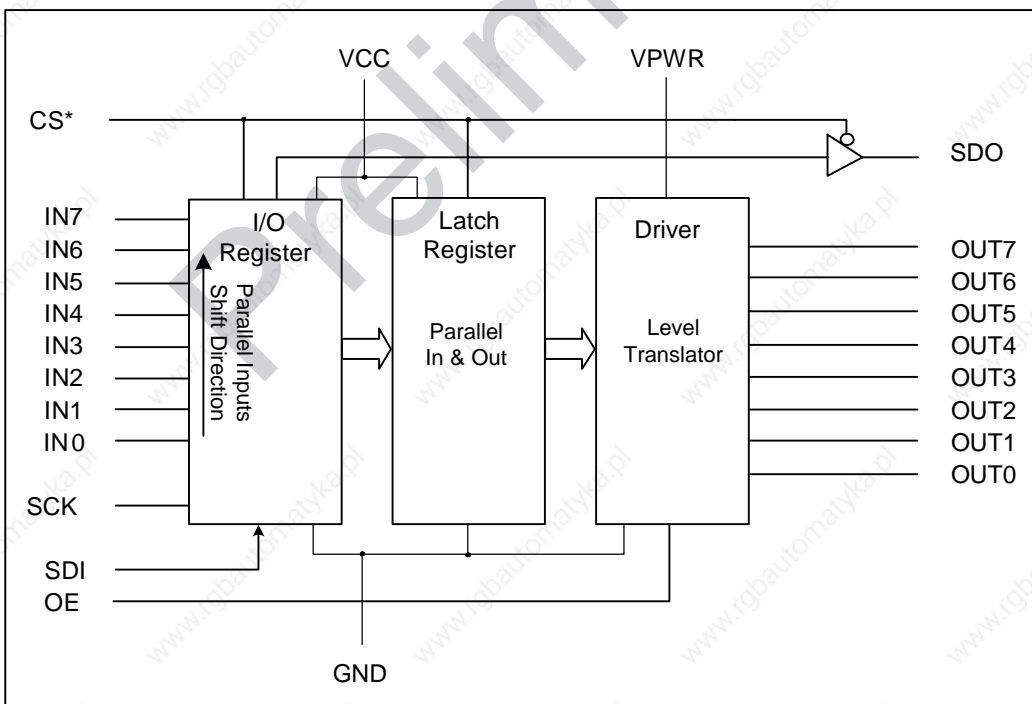

MX856 / MX857

Level Shifter and Output Driver

Features

- ✓ CMOS Technology
- ✓ TTL/CMOS compatible inputs
- ✓ Low switching noise
- ✓ 5 nS typical true / complement output skew
- ✓ 5 nS typical output rise and fall times
- ✓ Up to 20 V output voltage
- ✓ Output high voltage programmable via V_{OPT}
- ✓ Output low voltage programmable via V_{EE}

Applications

- Digital control of analog circuits
- Level shifting and amplification
- Circuit applications requiring complementary signal generation with low skew
- Bias control for PIN diode drivers in a microwave switch

General Description

The MX856 and MX857 are high speed single channel level shifters with complimentary output drivers. The MX856 features a 5.0 V V_{CC} positive supply, and the MX857 features a 3.3 V V_{CC} positive supply.

The input buffers accept digital TTL or CMOS level signals, amplifies them to the V_{CC} and GND supply rails, and generates complementary outputs. The translator level shifts these output signals by amplifying them to the V_{CC} and V_{EE} supply rails.

The output drivers then buffer the signals to V_{OPT} and V_{EE} . V_{OPT} may be set within the range of V_{CC} and GND. The output drivers also adjust the complimentary signals for minimized skew error.

The MX856 and MX857 are designed to operate over a temperature range of -40°C to $+85^{\circ}\text{C}$, and are available as die in wafer form, die in waffle pack, 8 lead SOIC package, and SOIC on Tape and Reel.

Ordering Information – MX856

Part No.	Description
19202	MX856 Die / Wafer Form
19201	MX856 Die / Waffle Pack
19200-00	MX856 8 Lead SOIC
19241-00	MX856 SOIC on Tape & Reel

Ordering Information – MX857

Part No.	Description
19302	MX857 Die / Wafer Form
19301	MX857 Die / Waffle Pack
19300-00	MX857 8 Lead SOIC
19341-00	MX857 SOIC on Tape & Reel

Functional Block Diagram

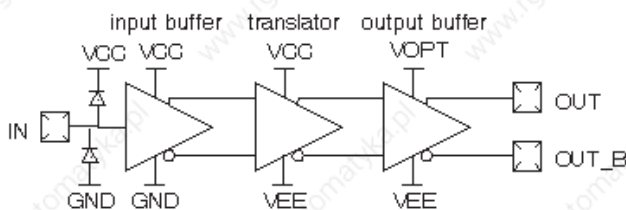

8 Lead SOIC Configuration

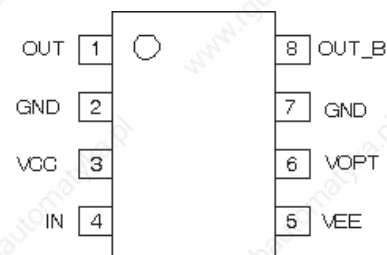

DE Linear and Switch Mode Series

The patented DE-SERIES Fast Power™ MOSFETs are in a new class of unique high power transistors designed as a circuit element from the ground up for high speed, high frequency, high power applications at frequencies up to 100 MHz. DEI's Fast Power™ technology features low insertion inductance (≤ 1.5 nH), and a low profile package, with

$R_{(\theta JA)}$ as low as 0.17°C/W , which provides exceptional switching speeds and power handling capabilities. The DE-Series MOSFETs offer 10 times the speed and 3 times the thermal dissipation, with $1/2$ the volume, $1/3$ the weight and greatly reduced die stress, of comparable conventional power MOSFET devices.

Features

- Isolated Substrate
 - high isolation voltage (> 2500 V)
 - excellent thermal transfer
 - increased temperature and power cycling capability
- IXYS advanced low Q_g process
- Low gate charge and capacitances
 - easier to drive
 - faster switching
- Low $R_{DS(on)}$
- Very low insertion inductance (≤ 1.5 nH)

Advantages

- Optimized for RF and high speed switching at frequencies to 175 MHz
- Higher voltages - lower DC current requirements, higher load impedances, reduced system size and weight, simplifies paralleling of devices
- Easy to mount - no insulators needed
- High power density

Applications

- RF Power Amplifiers
- High Frequency SMPS
- Laser Diode Drivers
- RF Power Generators
- Induction Heating
- High Speed Pulse Generators

Linear Z-MOS

Part Number ▶ New	Configuration	B_{VDSS}	I_d A	Gain 175 MHz dB	Pout 175 MHz W	Pd W	Fig. No.	Package Style Outlines page 188 - 224
100V (operating) Linear RF MOSFETS								
IXZ210N50L	SINGLE	500	10	14	300	550	D2	DE 275 Weight = 2 g
IXZ2210N50L	PUSH-PULL		10X2	14	550	1080	D3	
▶ IXZ12210N50L-754	PUSH-PULL		10X2	14	550	1080	754	
IXZH10N50LA	SINGLE G-S-D		9	14	150	180	X016a	
IXZH10N50LB	SINGLE D-S-G		9	14	150	180	X016a*	
50V (operating) Linear RF MOSFETS								
IXZ215N12L	SINGLE	125	15	13	150	300	D2	DE 275x2 Weight = 4 g

Switch Mode Z-MOS FETs

Part Number ▶ New	Configuration	BV_{DSS}	I_b A	$R_{DS(on)}$ Ω	t_r ns	C_{iss} pF	C_{oss} pF	C_{rss}	Pd	Fig.	Package Style
▶ IXZ211N50	SINGLE	500	11	0.6	4	790	78	12	540	D2	TO-247 AD Weight = 6 g
▶ IXZ2211N50	PUSH-PULL		11X2	0.6		790	78	12	1030	D3	
IXZ318N50	SINGLE		19	0.325		1960	139	19	880	D4	
▶ IXZH18N50	SINGLE		19	0.325		1960	139	19	300	X014a	
▶ IXZR18N50	SINGLE		19	0.325		1960	139	19	300	X016a	
IXZR18N50A	SINGLE G-S-D		19	0.325		1960	139	19	300	X016a	ISOPLUS247™ Weight = 5 g
IXZR18N50B	SINGLE D-S-G		19	0.325		1960	139	19	300	X016a*	
IXZ316N60	SINGLE	600	18	0.44	4	1930	125	17.8	880	D4	
▶ IXZH16N60	SINGLE		18	0.44					300	X014a	
▶ IXZR16N60	SINGLE		18	0.44					300	X016a	
IXZR16N60A	SINGLE G-S-D		18	0.44					300	X016a	X016a* D/G are pin swarped
IXZR16N60B	SINGLE D-S-G		18	0.44					300	X016a*	
IXZ308N120	SINGLE	1200	8	2.1	5	1960	59	9.2	880	D4	
▶ IXZH08N120	SINGLE		8	2.1					300	X014a	
▶ IXZR08N120	SINGLE		8	2.1					300	X016a	
IXZR08N120A	SINGLE G-S-D		8	2.1					300	X016a	
IXZR08N120B	SINGLE D-S-G		8	2.1					300	X016a*	

RF MOSFET Gate Driver IC



The DEIC 420 ultra-fast high current driver is optimized to drive DEI DE-Series MOSFETs for high efficiency performance in RF generators, laser diode drivers, pulse generators, and high frequency power conversion applications. It is designed to switch power MOSFETs with

minimum switching times at frequencies to 45 MHz. The innovative DEIC 420 is manufactured in DEI's patented low-inductance RF package, offering superior thermal performance and high continuous operating frequencies.

Features

- Wide operating voltage range from 8 V to 30 V
- Very low output impedance
- No internal cross conduction which allows operating frequencies to 45 MHz
- Latch-up protected to rated reverse current
- Output Current - up to 20 A peak
- Very low thermal impedance
- Matched rise and fall times
- Evaluation Board available

Applications

- Class D and E RF Generators
- Laser Diode Drivers
- High Frequency Power Factor Correction
- Acoustic Transducer Drivers
- High Frequency SMPS
- Pulse Generators

Fig. D1
DE 150



Fig. D2
DE 275



X550
28-pin SOP

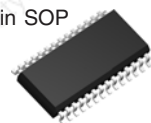

MOSFET Driver ICs

Part Number ▶ New	Configu- ration	Peak I A	Zout Ω	Package	PD W	Enable Pin	Kelvin Input	Evaluation Board
DEIC420	SINGLE	20	0,6	DE275	100	NO	NO	EVIC420
▶ DEIC421	SINGLE	20	0,6	DE275-IC	100	NO	YES	
▶ DEIC515	SINGLE	15	0,6	DE150-IC	100	NO	YES	
IXDD415SI	DUAL	15	0,8	SOIC-28 w/ heat slug	12	YES	YES	EVDD415

Outline drawings
see pages 188-224

Laser Diode Driver IC

Part Number	Pulse Width	Max Freq.	Peak I A	Package	Evaluation Board
IXLD02SI	1.5nS to >1μS	17MHz	2	SOIC-28 w/heat slug	EVLD02







GaAs Schottky Diodes

Part type	V _{RRM} V	I _f (25) A	C _{junction} Pf	V _F (I _F =24) Pf	PTOT(25) W	R _{THJC} K/W	Package
GS150TA_25104	250	4Ax3	9	1,5	9	16,3	DE150
GS150TC_25104	250	4Ax3	9	1,5	9	16,3	DE150
GS150TI_25104	250	4Ax3	9	1,5	9	16,3	DE150
GS150TA_25110	250	10Ax3	18	1,5	15	9,6	DE150
GS150TC_25110	250	10Ax3	18	1,5	15	9,6	DE150
GS150TI_25110	250	10Ax3	18	1,5	15	9,6	DE150
GS150TC_25120	250	20Ax3	36	1,5	20	7,2	DE150
GS08DI25104	250	1AX2	9	1,5	1	125	SOIC8









Switch Mode MOSFETs

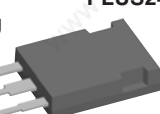

DE Series (DE Package)

Part Number	Configuration	B_{VDSS} V	I_D A	$R_{DS(ON)}$ Ω	$T_{R(ON)}$ ns	C_{ISS} pF	C_{OSS} pF	C_{RSS} pF	PD W	Fig. No.	Package style Outline drawings on page 188 - 224
100V (max) Switch Mode MOSFETs											
DE150-101N09A	SINGLE	100	9	0.16	4	800	200	30	200	D1	D1 Weight = 2 g 
DE275-101N30A	SINGLE		30	0.05	5	2500	500	100	270	D2	
200V (max) Switch Mode MOSFETs											
DE150-201N09A	SINGLE	200	15	0.2	4	700	150	20	200	D1	D2 Weight = 2 g 
DE275-201N25A	SINGLE		25	0.08	5	2500	250	50	590	D2	
500V (max) Switch Mode MOSFETs											
DE150-501N04A	SINGLE	500	4.5	1.5	4	700	90	5	200	D1	D3 Weight = 4 g 
DE275-501N16A	SINGLE		16	0.4	2	1800	150	40	590	D2	
DE275X2-501N16A	PUSH-PULL		16	0.38	2	1800	150	45	1180	D3	D4 Weight = 3 g 
DE375-501N21A	SINGLE		25	0.22	3	2000	200	45	940	D4	
DE475-501N44A	SINGLE		44	0.11	5	5500	230	130	1800	D5	
1000V (max) Switch Mode MOSFETs											
DE150-102N02A	SINGLE	1000	2	7.8	4	500	150	3	200	D1	D5 Weight = 3 g 
DE275-102N06A	SINGLE		8	1.6	2	1800	130	25	590	D2	
DE275X2-102N06A	PUSH-PULL		16	1.6	2	1800	130	25	1180	D3	X014a Weight = 6 g 
DE375-102N10A	SINGLE		10	1.2	3	2900	100	25	940	D4	
DE375-102N12A	SINGLE		12	0.95	3	2000	150	30	940	D4	
DE475-102N20A	SINGLE		20	0.6	5	5600	175	50	1800	D5	
DE475-102N21A	SINGLE		24	0.41	5	5500	200	60	1800	D5	

F Series (Industry Standard Packages)

Part Number	Configuration	B_{VDSS} V	I_D A	$R_{DS(ON)}$ Ω	$T_{R(ON)}$ ns	C_{ISS} pF	C_{OSS} pF	C_{RSS} pF	PD W	Fig. No.		
200V (max) Switch Mode MOSFETs												
IXFH60N20F	SINGLE	200	60	0.038	14	2930	940	320	315	X014a	X015 Weight = 5 g 	
IXFT60N20F	SINGLE	200	60	0.038	14	2930	940	320	315	X019		
500V (max) Switch Mode MOSFETs												
IXFH12N50F	SINGLE	500	12	0.4	14	1870	290	90	180	X014a	X016a Weight = 5 g 	
IXFT12N50F	SINGLE		12	0.4	14	1870	290	90	180	X019		
IXFH21N50F	SINGLE		21	0.25	12	2600	470	160	300	X014a		
IXFT21N50F	SINGLE		21	0.25	12	2600	470	160	300	X019		
IXFH28N50F	SINGLE		28	0.19	13	3000	500	130	315	X014a		
IXFT28N50F	SINGLE		28	0.19	13	3000	500	130	315	X019		
IXFK44N50F	SINGLE		44	0.12	18	5500	990	330	500	X020		
IXFX44N50F	SINGLE		44	0.12	18	5500	990	330	500	X015	X020 Weight = 10 g 	
IXFK55N50F	SINGLE		55	0.085	20	6700	1250	330	560	X020		
IXFN55N50F	SINGLE		55	0.085	20	6700	1250	330	600	X027b	X027a Weight = 30 g 	
IXFX55N50F	SINGLE		55	0.085	20	6700	1250	330	560	X015		
1000V (max) Switch Mode MOSFETs												
IXFH6N100F	SINGLE		1000	6	1.9	14	1870	190	60	180	X014a	
IXFT6N100F	SINGLE			6	1.9	14	1870	190	60	180	X019	
IXFH12N100F	SINGLE	12		1.05	12	2700	305	93	300	X014a		
IXFR12N100F	SINGLE	12		1.05	12	2700	305	93	300	X016a		
IXFT12N100F	SINGLE	12		1.05	12	2700	305	93	300	X014a		
IXFK21N100F	SINGLE	21		0.5	16	5500	640	190	500	X020		
IXFX21N100F	SINGLE	21		0.5	16	5500	640	190	500	X015		
IXFK24N100F	SINGLE	24		0.39	18	6600	760	230	560	X020		
IXFN24N100F	SINGLE	24		0.39	18	6600	760	230	600	X020		
IXFX24N100F	SINGLE	24		0.39	18	6600	760	230	560	X015		

Hybrid Microwave Modules

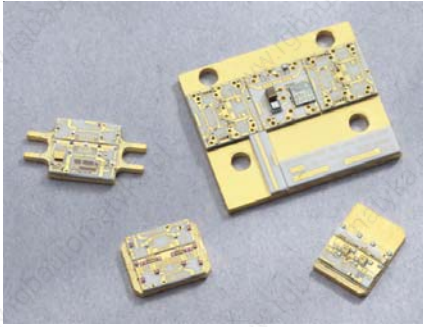

- Miniature, Low Cost for Drop In Hybrid Applications
- Low Noise, High Gain, and High Power Options
- Gain Block, Temp Comp, and Regulator Options
- Low VSWR for Improved Cascade Performance
- Single Voltage Supply and Low Current Design
- Using MwT's Space-Qualified GaAs and Thin Film Substrates
- 100% Eutectic Assembly Technique Assure High Reliability
- Standard and Customer Specific Specifications
- Connectorized Amplifier Options Upon Request
- High-Rel and Space-Rel Screening Available

MwT Standard Gain Block Modules

Model	Freq Range	Linear Gain	Gain ± Flatness	VSWR : 1 In & Out	Reverse Isolation	Noise Figure	Pout @ -1 dB	IP3	Current @ +8 V	Case Code	Carrier Size
▶ New	GHz	Typ/Min dB	Typ/Max dB	Typ/Max dB	Typ dB	Typ dB	Typ/Min dBm	Typ	Typ/Max mA		mil x mil
MwT 0206-1G1	2.0-6.0	16.0 / 15.0	0.6 / 0.6	1.8 / 2.0	-30.0	4.5	17.0 / 16.0	27.0	150 / 180	U/L-1	300 • 600
MwT 0206-1G2	2.0-6.0	18.0 / 17.0	0.5 / 0.6	1.8 / 2.0	-30.0	3.5	19.0 / 18.0	29.0	150 / 200	U/L-1	300 • 600
MwT 0206-2P2	2.0-6.0	10.5 / 10.0	0.4 / 0.6	1.5 / 1.8	-20.0	4.5	24.5 / 24.0	35.0	220 / 260	S/Z-1	300 • 600
MwT 0206-7G2	2.0-6.0	11.0 / 10.5	0.4 / 0.6	1.5 / 1.8	-20.0	3.0	15.0 / 14.0	25.0	60 / 80	S/Z-1	300 • 600
MwT 0206-9P2	2.0-6.0	11.0 / 10.0	0.4 / 0.6	1.7 / 2.0	-20.0	4.0	26.0 / 25.0	37.0	260 / 290	S/Z-1	300 • 600
MwT 0206-11P2	2.0-6.0	6.0 / 5.0	0.4 / 0.6	1.7 / 2.0	-18.0	7.0	30.0 / 29.5	41.0	850 / 950	S/Z-1	300 • 600
▶ MwT 0206-A9G1	2.0-6.0	17.0 / 16.0	0.5 / 0.6	1.8 / 2.0	-30.0	1.5	15.0 / 14.0	25.0	50 / 55	S/Z-1	300 • 600
MwT 0618-2P1	6.0-18.0	5.0 / 4.5	0.4 / 0.6	1.5 / 1.7	-20.0	7.0	24.8 / 24.0	35.0	200 / 250	S/Z-2	250 • 500
MwT 0618-2P2	6.0-18.0	5.5 / 5.0	0.3 / 0.5	1.5 / 1.7	-20.0	7.0	25.5 / 24.5	36.0	220 / 275	S/Z-2	250 • 500
MwT 0618-3P1	6.0-18.0	6.0 / 5.0	0.4 / 0.6	1.5 / 1.7	-20.0	6.5	20.5 / 20.0	30.0	100 / 120	S/Z-2	250 • 500
MwT 0618-3P2	6.0-18.0	6.5 / 6.0	0.3 / 0.5	1.5 / 1.7	-20.0	6.5	21.5 / 21.0	31.0	100 / 120	S/Z-2	250 • 500
MwT 0618-4N1	6.0-18.0	7.5 / 7.0	0.4 / 0.6	1.5 / 1.7	-20.0	4.5	14.0 / 12.0	25.0	40 / 60	S/Z-2	250 • 500
MwT 0618-4N2	6.0-18.0	8.0 / 7.5	0.4 / 0.6	1.5 / 1.7	-20.0	4.0	14.0 / 11.0	25.0	40 / 60	S/Z-2	250 • 500
MwT 0618-H4N2	6.0-18.0	9.0 / 8.5	0.4 / 0.6	1.5 / 1.7	-20.0	3.0	10.0 / 7.0	20.0	40 / 60	S/Z-2	250 • 500
MwT 0618-5G1	6.0-18.0	10.0 / 9.5	0.4 / 0.6	1.5 / 1.7	-30.0	5.5	16.0 / 14.0	26.0	90 / 100	S/Z-2	250 • 500
MwT 0618-5G2	6.0-18.0	10.5 / 10.0	0.4 / 0.6	1.5 / 1.7	-30.0	5.0	18.0 / 15.5	28.0	100 / 120	S/Z-2	250 • 500
MwT 0618-7G2	6.0-18.0	7.5 / 7.0	0.4 / 0.6	1.5 / 1.7	-20.0	5.0	15.0 / 14.0	25.0	60 / 80	S/Z-2	250 • 500
MwT 0618-12P2	6.0-18.0	4.6 / 4.2	0.4 / 0.6	1.5 / 1.7	-20.0	7.5	27.5 / 27.0	38.0	350 / 450	S/Z-2	250 • 500
▶ MwT 0618-H15P2	6.0-18.0	8.5 / 7.5	0.4 / 0.6	1.5 / 1.7	-20.0	7.5	27.0 / 26.0	34.0	250 / 275	S/Z-2	250 • 500
▶ MwT 0618-H15P3	6.0-18.0	7.5 / 6.5	0.4 / 0.6	1.5 / 1.7	-20.0	7.5	29.0 / 28.0	36.0	250 / 300	S/Z-2	250 • 500
▶ MwT 0618-H16P3	6.0-18.0	5.0 / 6.0	0.8 / 1.2	1.7 / 2.0	-17.0	8.0	30.0 / 29.0	38.0	450 / 550	S/Z-2	250 • 500
▶ MwT 0618-H7P2	6.0-18.0	9.0 / 9.5	0.5 / 1.0	1.7 / 2.0	-17.0	5.5	21.0 / 24.0	33.0	110 / 150	S/Z-2	250 • 500
MwT 0820-3P1	8.0-20.0	5.0 / 4.5	0.4 / 0.6	1.5 / 1.7	-20.0	7.5	19.0 / 18.0	29.0	100 / 120	S/Z-2	250 • 500
MwT 0820-3P2	8.0-20.0	5.5 / 5.0	0.4 / 0.6	1.5 / 1.7	-20.0	7.0	20.0 / 19.0	29.0	100 / 120	S/Z-2	250 • 500
MwT 0820-4N1	8.0-20.0	6.0 / 5.5	0.4 / 0.6	1.5 / 1.7	-20.0	8.0	14.0 / 12.0	25.0	40 / 60	S/Z-2	250 • 500
MwT 0820-4N2	8.0-20.0	6.5 / 6.0	0.4 / 0.6	1.5 / 1.7	-20.0	4.0	14.0 / 11.0	25.0	40 / 60	S/Z-2	250 • 500
MwT 0820-5G1	8.0-20.0	9.0 / 8.0	0.4 / 0.6	1.5 / 1.7	-28.0	4.0	16.0 / 14.0	26.0	90 / 110	S/Z-2	250 • 500
MwT 0218-4N1	2.0-18.0	6.0 / 5.0	0.8	1.7 / 2.0	-20.0	7.0	15.0 / 14.0	25.0	100 / 120	S/Z-2	250 • 500
MwT 0218-4N2	2.0-18.0	6.5 / 6.0	1.2	1.7 / 2.0	-20.0	8.5	17.0 / 16.0	26.0	160 / 180	S/Z-2	250 • 500
MwT 0218-H4N1	2.0-18.0	12.0 / 11.0	0.8	1.7 / 2.0	-20.0	4.0	6.0 / 5.0	15.0	40 / 50	S/Z-2	250 • 500
▶ MwT 0218-H4N2	2.0-18.0	11.0 / 10.0	0.8	1.7 / 2.0	-20.0	4.0	12.0 / 11.0	24.0	60 / 75	S/Z-2	250 • 500

Note: Typical 2nd Harmonics @ P-I -21.0 dBc Typ

MwT Standard Temperature Compensation Modules

Model	Freq Range	Insertion Loss	Loss Flatness	Atten.	Current @ +8 V	Case Code	Carrier Size
	GHz	Typ/Max dB	± Max dB	Typ / Min dB	Max mA		milxmil
MwT 0206-TCM	2.0-6.0	1.0 / 2.5	0.4 / 0.6	13.0 / 12.0	10 / 20	S/Z-1	300 • 600
MwT 0618-TCM	6.0-18.0	2.5 / 3.0	0.4 / 0.6	13.0 / 12.0	10 / 20	S/Z-2	250 • 500

MwT Standard Voltage Regulator Modules (Each Module Contains Dual Adjustable Voltage Regulators)

Model	Freq Range	Insertion Loss	Ripple Rej @ 120Hz	Pw Diss Per VR	Regulated Voltage	Supply Voltage	Total Sup. Current	Case Code	Carrier Size
	GHz	Typ/Max dB	Min dB	Max Watts	Min / Max V	Typ / Max V	Max mA		milxmil
MwT 0206-VRM	2.0-6.0	- / 0.5	50.0	1.5	7.9 / 8.1	12.0 / 20.0	800	U/L-1	300 • 600
MwT 0618-VRM	6.0-18.0	- / 1.0	50.0	1.5	7.9 / 8.1	12.0 / 20.0	800	U/L-2	250 • 500

Standard Amplifier Selection Guide



Model Number WideBand Amplifier Type	Freq Range GHz	Linear Gain dB MIN/TYP	Gain Flatness ±dB MAX	Noise Figure dB MAX/TYP	Pout-1dB dBm MIN/TYP	Current @12 V mA MAX	Case Code
AW052202N	0.5-2	30/33	1-4	2.5/2.2	15/17	300	SL-2
AW052203	0.5-2	23/26	1.0	3.0/2.5	17/19	260	SL-2
AW054201N	0.5-4	19/26	1.0	2.5/2.2	15/17	220	SL-2
AW054203	0.5-4	21/24	1.0	4.5/4.0	16/18	260	SL-2
AW12201N	1-2	28/31	1-1	2.5/2.2	18/20	225	SL-2
AW12203	1-2	27/30	1-1	3.5/3.0	27/28	555	SL-2
AW26201N	2-6	21/23	1.0	2.5/2.2	13/15	155	SL-2
AW26204	2-6	19/21	1.0	4.5/4.0	23/24	335	SL-2
AW28201N	2-8	29/32	1-5	3.0/2.5	13/15	175	SL-2
AW28302	2-8	31/33	1-5	5.5/5.0	23/24	615	SL-3
AW612301N	6-12	30/32	1.0	3.5/3.0	16/17	240	SH-3
AW612304	6-12	22/23	1.0	6.5/6.0	27/28	750	SH-4
AW1218301N	12-18	24/26	0.8	3.5/3.0	14/15	230	SH-3
AW1218504	12-18	29/31	1-3	7.5/7.0	27/28	1200	SH-6
AW818301N	8-18	24/26	1.0	3.5/3.0	14/15	230	SH-3
AW818504	8-18	29/32	1-5	7.5/7.0	27/28	1300	SH-6
AW618301N	6-18	24/26	1-3	3.5/3.0	14/15	230	SH-3
AW618302	6-18	19/21	1-3	6.0/5.5	20/21	350	SH-3
AW618404	6-18	20/22	1-5	7.5/7.0	27/28	1200	SH-5
AW218201N	2-18	25/28	1-8	5.0/4.5	6/7	135	SH-2
AW218301N	2-18	24/26	2.0	6.5/6.0	15/16	365	SH-3
AW218301	2-18	20/22	2.0	6.0/5.5	20/21	500	SH-3
Model Number Temp Comp Amplifier Type	Freq Range GHz	Linear Gain dB MIN/TYP	Gain Flatness ±dB MAX	Noise Figure dB MAX/TYP	Gain vs Temp ±dB MAX	Current @12 V mA MAX	Case Code
AT26301	2-6	21/23	1.0	6.0/5.5	0.8	300	SL-3
AT26401	2-6	36/40	1.5	5.5/5.0	1.0	470	SL-4
AT618401	6-18	22/24	1.0	7.5/7.0	0.8	380	SH-4
AT618501	6-18	31/33	1.3	7.0/6.5	0.8	500	SH-5
Model Number Limiting Amplifier Type	Freq Range GHz	Pin Dynamic dBm MIN/MAX	Noise Power dBm MAX	Pout-sat dBm MIN/MAX	Pout Flatness ±dB MAX	Current @12 V mA MAX	Case Code
AL26501	2-6	-50/10	7.0	+15/+20	1.0	500	SL-5
AL618801	6-18	-50/10	10.0	+15/+20	2.0	800	LH-44
Model Number Low Noise Amplifier Type	Freq Range GHz	Linear Gain dB MIN	Gain Flatness ±dB MAX	Noise Figure dB MAX/TYP	Pout-1dB dBm MIN/TYP	Current @12 V mA MAX	Case Code
AN12201N	1.2-1.8	28/31	0.5	1-7	15/17	180	CL-1
AN23201N	2.2-2.9	28/31	0.5	1-7	15/17	180	CL-1
AN45201N	4.4-5.0	25/27	0.5	1-7	15/17	180	CL-1
AN78201N	7.2-7.8	23/25	0.5	1-8	14/16	150	CH-1
AN910201N	9.0-10.0	21/23	0.5	1-8	14/16	150	CH-1
AN1415301N	14.5-15.3	24/27	0.5	2-1	13/15	200	CH-3
AN1718401N	17.7-18.7	29/32	1.0	2-8	12/14	250	CH-3
Model Number Med Power Amplifier Type	Freq Range GHz	Linear Gain dB MIN	Gain Flatness ±dB MAX	VSWR In/Out MAX	Pout-1dB dBm MIN/TYP	Current @12 V mA MAX	Case Code
AP45401	4.4-5.0	35.0	0.6	1.5/1.5	30.0/30.5	1400	CL-3
AP67402	5.9-6.4	33.0	0.6	1.5/1.5	33.0/33.5	2700	CL-3
AP78401	7.2-8.4	33.0	0.8	1.5/1.5	30.0/30.5	1450	CH-3
AP910401	9.0-10.0	32.0	0.8	1.5/1.5	30.0/30.5	1450	CH-3
AP1011401	10.7-11.7	27.0	0.8	1.5/1.5	30.0/30.5	1550	CH-3
AP1415401	14.0-14.5	23.0	0.5	1.5/1.5	29.0/30.0	1700	CH-3
AP1718501	17.7-18.7	24.0	1.0	1.8/1.8	26.0/27.0	1250	CH-5
Model Number Telecom Power Amplifier Type	Freq Range GHz	Linear Gain dB MIN	Gain Flatness ±dB MAX	IMD3 (dBc) @ Po dBm/Tone	Pout-1dB dBm MIN/TYP	Current @12 V mA MAX	Case Code
AP1819701	18.1-18.6	30	0.5	-50@+15	27	2300	PH-01
AP1819801	18.1-18.6	35	0.5	-54@+15	29	2700	PH-01

Contact factory for application assistance on custom and standard amplifiers. High-Rel and Space-Rel screening available.

- Ultra Linear, High Dynamic Range, Low Phase Noise
- GaAs Process is Approved for Space Applications with Proven Reliability
- Commercial, Industrial, Military, and Space Grades
- 100% Wafer Bond Pull, Die Shear, Wafer DC Burn In, and Bake Tests in Evaluation per mil-PRF 385 & 4
- 100% Die Probe Test with Data Recorded for Shipment
- 100% Visual (Perform Level 1, 3, or 4) before Shipment
- 100% Idss Match to Provide Performance Consistency
- RF Sample Test Capability Available Upon Request
- Meet Standard or Customer Specific Specifications
- High-Rel and Space-Rel Screening Options Available
- RoH5 (lead-free) compliant product available

MwT Standard GaAs FETs / PHEMTs RF Properties (DC Properties Listed on 2nd Page)

Model	Package Available Sealed / Hermetic	Gate Width / Length um	Gate Layout Method	Gate Drain Source Bond Pads Qty	Chip Thickness & VIA mil, y/n	S.S. Gain @12GHz Typ/Min dB	N. F. @12GHz Typ/Max dB	Ga @ N.F. @12GHz Typ/Min dB	P-1dB @ 12GHz Typ/Min dBm	IP3 @ 12GHz Typ dBm	Nominal Chip Size um • um	Ideal Circuit
► New												
MwT-1	70, 73 / 71	630/0.3	single stripe	1, 1, 2	5, no	10.0 / 9.0	2.0 / -	7.0 / -	24.0/23.0	-	775 • 241	FB Amp
MwT-2	70, 73 / 71	630/0.3	single stripe	2, 2, 3	5, no	8.5 / 8.0	- / -	- / -	24.5/23.0	-	775 • 241	BA Amp
MwT-3	70, 73 / 71	300/0.3	single stripe	1, 1, 2	5, no	11.0 / 10.0	- / -	- / -	21.0/20.0	-	406 • 241	BA Amp
MwT-4	70, 73 / NA	180/0.3	single stripe	1, 1, 2	5, no	9.0 / 8.0	1.5 / 1.8	9.0 / 8.0	14.0/13.0	-	356 • 241	Osc & Amp
MwT-5	NA / NA	2•300/0.3	dual gate	3, 1, 2	5, no	13.0 / 12.0	3.5 / -	11.0 / -	19.0/15.0	-	406 • 241	Buffer Amp
MwT-6	- / 71	900/0.3	Interdigit	2, 2, 3	5, no	8.0 / 7.5	- / -	- / -	27.0/26.0	-	559 • 292	FB/DA Amp
MwT-7	70, 73 / NA	250/0.3	single stripe	2, 2, 2	5, no	10.5 / 10.0	2.0 / -	8.0 / -	20.0/18.0	-	356 • 241	BA/SE Amp
► MwT-8	71.0	2400/0.3	Interdigit	2, 2, 3	4, no	7.5 / 7.0	-	-	28.0 / 27.0	-	673 • 305	Power Amp
MwT-9	70, 73 / 71	750/0.3	Interdigit	1, 1, 2	5, no	9.0 / 8.0	- / -	- / -	26.0/25.0	-	419 • 292	FB Amp
► MwT-11	71.0	2400/0.3	Interdigit	2, 2, 3	4, no	9.0 / 7.0	-	-	30.0 / 28.0	-	775 • 343	Power Amp
MwT-15	- / -	630/0.3	single stripe	4, 2, 5	5, no	9.5 / 8.5	- / -	- / -	25.0/23.0	-	775 • 241	Amplifier
MwT-16	- / -	900/0.3	single stripe	6, 2, 7	5, no	8.5 / 7.5	- / -	- / -	27.0/26.0	-	1067 • 241	BA Amp
MwT-17	89 / 71	2400/0.8	Interdigit	4, 4, 5	5, no	7.0 / 6.0	0.8@0.9GHz	-	29.5/28.5	45/-	1130 • 279	BA/FB Amp
► MwT-1789HL	sot89	2400/0.8	Interdigit	4, 4, 5	4, no			14.0**	28.0	46	1130 • 279	High Linearity
► MwT-1789LN*	sot89	2400/0.8	Interdigit	4, 4, 5	4, no			16.0**	28.0	46	1130 • 279	Low Noise
► MwT-17QFN	QFN	2400/0.8	Interdigit	4, 4, 5	4, no	18.0/16.0**	1.5**	-	28.0/27.0	46	1130 • 279	Power Amp
► MwT-22	71.0	4800/0.5	Interdigit	6, 6, 7	4, no	12.0 / 9.0	-	-	33.0/31.0	48	1651 • 508	Power Amp
► MwT-22QFN	QFN	4800/0.5	Interdigit	6, 6, 7	4, no	13.5/12.0***	-	-	33.0/32.0	48	1651 • 508	Power Amp
► MwT-24	-	12000/0.5	Interdigit	5, 5, 6	4, no	11.0 / -	-	-	36.0/NA	48	2311 • 508	Power Amp
► MwT-25	-	14400/0.5	Interdigit	6, 6, 7	4, no	10.0 / 9.0	-	-	37.5/36.0	48	2757 • 508	Power Amp
MwT-A9	84, 70, 73 / 71	750/0.3	single stripe	1, 1, 2	5, no	9.5 / 8.5	1.8 / -	6.5 / 6.0	25.5/23.0	-	419 • 292	FB Amp
► MwT-A989SB	sot89	750/0.5	Interdigit	1, 1, 2	4, no	17.0/15.0**	0.9**	-	25.0/23.0	40	419 • 292	Power Amp
► MwT-H7	70, 73 / -	250/0.3	single stripe	2, 2, 2	5, no	12.0 / 11.0	2.0 / -	10.0 / -	21.5/20.0	-	356 • 241	BA Amp
► MwT-LP7	70, 73 / NA	250/0.3	single stripe	2, 2, 2	5, no	10.5 / 10.0	2.0 / -	8.0 / -	20.0/18.0	-	356 • 241	Oscillator
► MwT-PH15	70, 73 / 71	630/0.3	single stripe	3, 2, 5	4, no	12.0 / 10.0	-	-	28.5/27.0	-	775 • 241	Medium pow
► MwT-PH16	71	900/0.3	single stripe	6, 2, 7	4, no	11.5 / 10.0	-	-	30.0/28.5	-	1067 • 241	Medium pow
► MwT-PH7	70, 73 / 71	250/0.3	single stripe	2, 1, 2	4, no	13.5 / 12.0	-	-	24.0/22.0	-	356 • 241	Medium pow
► MwT-PH8	71	1200/0.3	Interdigit	2, 2, 3	4, no	10.0 / 9.0	-	-	30.0/29.0	-	673 • 305	Medium pow

* noise figure = 1.3dB @2.0Ghz

GaAs FETs / PHEMTs

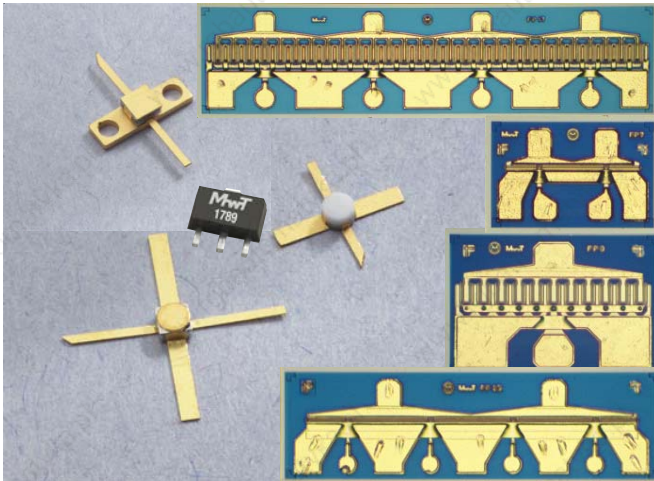

MwT Standard GaAs FETs / PHEMTs RF Properties (RF Properties Listed on First Page)

Model	Device Type	I _{dss} Range Min/Max	I _{dss} Range in Each Container	G _m Tested at V _{ds} /V _{gs}	G _m Typ/Min	V _p Tested at V _{ds} /I _{ds}	V _p Typ/Max	B _{vgs0} Tested I _{gs}	B _{vgs0} Typ/Min	B _{vgs0} Tested at I _{gd}	B _{vgs0} Typ/Min	V _{ds} Absolute Max	Chip R _{th} Typ
► New		mA	mA	V/V	mS	V/mA	(- V)	(- mA)	(- V)	(- mA)	V/V	V	OC/W
MwT-1	MESFET	60 / 240	10	4.0 / 0.0	120 / 90	3.0 / 4.0	2.0 / 5.0	1.0	10.0 / 5.0	1.0	10.0 / 6.0	6.0	80
MwT-2	MESFET	60 / 240	10	4.0 / 0.0	100 / 75	3.0 / 4.0	2.0 / 5.0	0.4	12.0 / 6.0	0.4	12.0 / 8.0	7.0	80
MwT-3	MESFET	30 / 120	5	4.0 / 0.0	55 / 35	3.0 / 2.0	2.0 / 5.0	0.2	12.0 / 6.0	0.2	12.0 / 8.0	7.0	150
MwT-4	MESFET	18 / 66	3	3.0 / 0.0	35 / 27	3.0 / 1.0	1.5 / 4.0	0.2	8.0 / 5.0	0.2	8.0 / 6.0	6.0	250
MwT-5	MESFET	30 / 110	5	2.0 / 0.0	40 / 23	3.0 / 0.0	2.0 / 4.5	0.4	8.0 / 5.0	0.4	10.0 / 7.0	6.5	150
MwT-6	MESFET	90 / 360	15	2.0 / 0.0	145 / 108	3.0 / 6.0	2.0 / 5.0	0.6	12.0 / 6.0	0.6	12.0 / 8.0	7.0	60
MwT-7	MESFET	26 / 98	4	3.0 / 0.0	45 / 36	3.0 / 1.0	1.5 / 4.5	0.4	8.0 / 5.0	0.4	8.0 / 6.0	6.0	180
► MwT-8	MESFET	120 / 480	20	2.5 / 0.0	160 / 144	3.0 / 5.0	2.0 / 5.0	1.2	12.0 / 8.0	1.2	12.0 / 8.0	7.5	45
MwT-9	MESFET	78 / 282	12	2.0 / 0.0	120 / 95	3.0 / 5.0	2.0 / 5.0	0.5	12.0 / 6.0	0.5	12.0 / 6.0	7.0	70
► MwT-11	MESFET	240 / 920	40	2.5 / 0.0	380 / 290	3.0 / 16.0	2.0 / 5.0	2.4	12.0 / 8.0	2.4	12.0 / 8.0	8.0	28
MwT-15	MESFET	60 / 240	10	4.0 / 0.0	100 / 75	3.0 / 4.0	2.0 / 5.0	0.4	12.0 / 6.0	0.4	12.0 / 8.0	7.0	80
MwT-16	MESFET	90 / 360	15	2.0 / 0.0	130 / 108	3.0 / 6.0	2.0 / 5.0	0.6	12.0 / 6.0	0.6	12.0 / 8.0	7.0	55
MwT-17	MESFET	240 / 920	40	2.0 / 0.0	380 / 290	3.0 / 6.0	2.5 / 5.0	1.6	12.0 / 6.0	1.6	12.0 / 8.0	7.0	33
► MwT-1789HL	MESFET	440 / 680	-	2.5 / 0.0	380	3.0 / 16.0	2.0 / 5.0	2.4	12.0 / 6.0	2.4	12.0 / 9.0	8.0	35
► MwT-1789LN*	MESFET	440 / 680	-	2.5 / 0.0	380	3.0 / 16.0	2.0 / 5.0	2.4	12.0 / 6.0	2.4	12.0 / 9.0	8.0	35
► MwT-17QFN	MESFET	440 / 680	NA	2.5 / 0.0	380	3.0 / 16.0	2.0 / 5.0	2.4	12.0 / 6.0	2.4	12.0 / 9.0	8.0	35
► MwT-22	MESFET	800/1200	100	2.5 / 0.0	650 / 500	3.0 / 30.0	2.0 / 5.0	5.0	12.0 / 8.0	0.5	14.0 / 12.0	9.0	12
► MwT-22QFN	MESFET	800 / 1200	NA	2.5 / 0.0	650	3.0 / 30.5	2.0 / 5.0	5.0	12.0 / 8.0	5.0	14.0 / 12.0	9.0	12
► MwT-24	MESFET	1800/2400	200	2.5 / 0.0	1200 / 1000	3.0 / 120.0	2.0 / 5.0	12.0	12.0 / 8.0	12.0	16.0 / 14.0	12.0	7
► MwT-25	MESFET	2000/2600	200	2.5 / 0.0	1500 / 1000	3.0 / 150.0	2.0 / 5.0	14.0	12.0 / 8.0	14.0	16.0 / 14.0	12.0	6
MwT-A9	MESFET	78 / 282	12	2.0 / 0.0	120 / 95	3.0 / 5.0	2.0 / 5.0	1.0	10.0 / 5.0	1.0	10.0 / 6.0	6.0	70
► MwT-A989SB	MESFET	100 / 200	NA	2.5 / 0.0	90 / 120	3.0 / 5.0	2.0 / 5.0	1.0	12.0 / 6.0	1.0	12.0 / 6.0	8.0	75
► MwT-H7	PHEMT	34 / 106	4	3.0 / 0.0	75 / 50	3.0 / 1.0	1.5 / 5.0	0.4	8.0 / 5.0	0.4	8.0 / 6.0	6.0	180
► MwT-LP7	MESFET	38 / 98	4	3.0 / 0.0	45 / 36	3.0 / 1.0	1.5 / 4.5	0.4	8.0 / 5.0	0.4	8.0 / 6.0	6.0	180
► MwT-PH15	PHEMT	120 / 240	10	2.5 / 0.0	200 / 130	3.0 / 2.0	1.2 / 2.5	1.0	12.0 / 6.0	1.0	13.0 / 10.0	8.0	65
► MwT-PH16	PHEMT	150 / 360	15	2.5 / 0.0	280 / 180	3.0 / 3.0	1.2 / 2.5	1.0	12.0 / 6.0	1.0	13.0 / 10.0	8.0	45
► MwT-PH7	PHEMT	50 / 122	4	2.5 / 0.0	80 / 50	3.0 / 1.0	1.2 / 2.5	0.4	12.0 / 6.0	0.4	12.0 / 8.0	7.0	150
► MwT-PH8	PHEMT	240 / 600	20	2.5 / 0.0	320 / 240	3.0 / 8.0	1.2 / 2.5	1.2	12.0 / 6.0	1.2	13.0 / 10.0	8.0	40

Wireless Amplifiers (MPS, ULA and WPS WiMax)



- Miniature, Low Cost, SMT, Flange, & Leadless Options
- Miniature, High Reliability, Hermetic SMT Options
- Low Noise, High Linearity, and Broad Band Options
- Suitable for High Dynamic Range LNA and Receiver
- Suitable for High Linear Driver Amp Gain Stages
- Low VSWR for Improved Cascade Performance
- Single Voltage Supply and Low Current Design
- Uses MwT's Space-Qualified GaAs Devices
- Most Parts are Eutectic Assembly for High Reliability
- Standard and Customer Specific Specifications
- High-Rel and Space-Rel Screening Available (class H, K, and S)

MwT Standard High Linearity Driver Amplifiers

Model (Case Code - XX)	Case Code (- XX) Sealed SMT, Flange Leadless	Case Code (- XX) Hermetic SMT	Freq Range MHz	Linear Gain Typ/Min dB	Gain ± Flatness Typ/Max dB	VSWR: 1 Input Typ dB	VSWR: 1 Output Typ dB	Noise Figure Typ/Max dB	Pout @ -1 dB Typ/Min dBm	IP3 Typ/Min dBm	DC Voltage Applied V	DC Current Typ/Max mA
► New												
MPS 0810A9D-XX	82, -	96	800-960	14.0/13.0	0.20/0.30	1.4	1.2	5.0 / -	26.0/25.0	42.0 / 41.0	7.5	220 / 280
MPS 093011-XX	82, 85	96	800-1000	16.0/14.0	0.25/0.50	1.5	2.2	6.0 / -	30.0/-	45.0 / 43.0	7.5	380 / 450
► ULA 818-XX	82, -	-	800-1000	15.5/14.0	0.25/0.50	1.5	1.5	-	28.0/-	48.0 / 46.0	8.0	270 / 350
MPS 173011-XX	82, 85	96	1400-1700	14.0/13.0	0.25/0.50	1.5	2.2	6.0 / -	30.0/-	45.0 / 42.0	7.5	380 / 450
MPS 213011-XX	82, 85, 02	96	1700-2100	14.0/13.0	0.25/0.50	1.5	2.2	6.0 / -	29.0/-	45.0 / 42.0	7.5	380 / 450
► ULA 808-XX	82, -	-	1800-2100	14.0/13.0	0.25/0.50	2.0	2.0	-	28.0/-	48.0 / 46.0	8.0	270 / 350
MPS 172208-XX	82, 85	-	1900-2000	13.0/12.0	0.20/0.50	2.0	2.0	5.0 / -	26.0/25.0	38.0 / -	7.5	380 / 450
MPS 1820A9D-XX	82, -, 02	-	1800-2000	14.0/13.0	0.20/0.30	1.4	1.2	5.0 / -	26.0/25.0	42.0 / 41.0	7.5	220 / 280
► MPS 182217-XX	82, -, 02	-	1800-2200	14.0/13.0	0.25/0.50	1.5	3.0	6.0 / -	28.5/-	45.0 / 42.0	7.5	380 / 450
MPS 2125A9D-XX	82, -, 02	-	2100-2500	14.0/13.0	0.20/0.50	1.4	1.2	5.0 / -	26.0/25.0	42.0 / 41.0	7.5	220 / 280
MPS 242520-XX	-, 83	-	2400-2500	13.0/12.0	0.30/0.50	3.0	2.0	-	36.0/35.0	52.0 / -	8.0	750 / 900
MPS 252730-XX	-, 83	-	2500-2700	13.0/12.0	0.40/0.60	3.0	2.0	-	36.0/35.0	52.0 / -	8.0	750 / 900
MPS 253011-XX	82, 85	96	2400-2700	13.0/12.0	0.25/0.50	1.5	2.2	6.0 / -	29.0/-	45.0 / 42.0	7.5	380 / 450
MPS 3435A9D-XX	82, -	-	3400-3500	13.0/12.0	0.20/0.30	1.4	1.3	6.0 / -	24.0/23.0	41.0 / 39.0	7.5	220 / 280
MPS 343517-XX	82, -	-	3400-3500	13.0/12.0	0.25/0.50	2.0	2.2	6.0 / -	29.0/-	45.0 / 42.0	7.5	380 / 450
► MPS-0810A9-02	02	-	800-960	15.0/14.0	0.20/0.80	1.5	2	1.1/1.5	20.5/-	34.0/-	6.0	160-240
► MPS-081017-02	02	-	800-1000	15.0/14.0	0.20/0.50	2.0	2.5	-	28.5/-	45.0/42.0	7.5	380-450
► MPS-0820A9D-02	02	-	800-2050	13.5/12.5	0.20/0.50	1.4	1.4	5.5 / -	24.0/-	43.0/-	6.0	220-280
► MPS-1720A9-02	02	-	800-960	14.0/13.0	0.20/0.50	2.1	1.5	1.1/1.5	20.0/-	33.0/-	6.0	100-140
► MPS-182117-02	02	-	1800-2100	14.0/13.0	0.25/0.50	2.0	2.5	1.1 / -	28.5/-	45.0/42.0	7.5	380-450
► MPS-242717-02	02	-	2400-2700	13.0/12.0	0.30/0.50	2.0	2.0	-	28.0/-	45.0/42.0	6.0-7.0	380-450
► MPS-343717-02	02	-	3400-3700	12.5/11.7	0.25/0.50	1.5	2.5	-	28.5/-	45.0/42.0	6.0-7.0	330-400
► MPS-081017P-02	02	-	800-960	14.0/13.0	0.20/0.50	2.0	2.0	1.3/1.7	26.0/-	44.0/-	6.0-7.0	330-400
► MPS-081017N-02	02	-	800-960	13.5/12.0	0.20/0.50	2.0	2.0	1.0/1.3	21.0/-	36.0/-	6.0-7.0	180-250
► MPS-343717-82	82	-	3400-3700	12.5/11.7	0.25/0.50	1.5	2.5	-	28.5/-	45.0/42.0	6.7	380-450
► MPS-343611-82	82	-	3400-3600	13.0/12.0	0.25/0.50	2.0	2.2	-	29.0/-	48.0/44.0	7.5	350-420
► MPS-363817-82	82	-	3600-3800	13.0/12.0	0.25/0.50	2.0	2.2	-	29.0/-	48.0/44.0	7.5	350-420

MwT Standard Low Noise Receiver Amplifiers

Model (Case Code - XX)	Case Code (- XX) Sealed SMT, Flange Leadless	Freq Range MHz	Linear Gain Typ/Min dB	Gain ± Flatness Typ/Max dB	VSWR: 1 Input Typ dB	VSWR: 1 Output Typ dB	Noise Figure Typ/Max dB	Pout @ -1 dB Typ dBm	IP3 Typ/Min dBm	DC Voltage Applied V	DC Current Typ/Max mA
MPS 080817P-XX	82, 85, 02	806-849	14.0/13.0	0.20/0.50	2.0	2.0	1.1 / 1.5	28.0	44.0 / 42.0	7.5	330 / 400
MPS 080817N-XX	82, 85, 02	806-849	13.5/12.0	0.20/0.50	2.0	2.0	0.8 / 1.0	23.0	36.0 / 33.0	7.5	180 / 250
MPS 0808A9-XX	-, 85	806-849	16.0/14.0	0.20/0.50	2.0	2.0	1.1 / 1.5	22.0	36.0 / 33.0	6.0	180 / 250
MPS 080917P-XX	NA, 85, 02	870-925	14.5/13.0	0.20/0.50	2.0	2.0	1.1 / 1.5	28.0	44.0 / 42.0	7.5	330 / 400
MPS 080917N-XX	82, 85, 02	870-925	13.5/12.0	0.20/0.50	2.0	2.0	0.8 / 1.0	23.0	36.0 / 33.0	7.5	180 / 250
MPS 0809A9-XX	82, 85	870-925	16.0/14.0	0.20/0.50	2.0	2.0	1.1 / 1.5	22.0	36.0 / 33.0	6.0	180 / 250
MPS 090917P-XX	82, 85, 02	925-960	14.5/13.0	0.20/0.50	2.0	2.0	1.1 / 1.5	28.0	44.0 / 42.0	7.5	330 / 400
MPS 090917N-XX	-, 85, 02	925-960	13.5/12.0	0.20/0.30	2.0	2.0	0.8 / 1.0	23.0	36.0 / 33.0	7.5	180 / 250
MPS 0909A9-XX	82, 85	925-960	16.0/14.0	0.20/0.50	2.0	2.0	1.1 / 1.5	22.0	36.0 / 33.0	6.0	180 / 250
MPS 1718A9-XX	82, 85	1710-1785	15.5/14.0	0.20/0.50	2.0	2.0	1.1 / 1.5	22.0	36.0 / 33.0	6.0	100 / 150
MPS 1820A9-XX	82, 85	1850-1910	15.5/14.0	0.20/0.50	2.0	2.0	1.1 / 1.5	22.0	36.0 / 33.0	6.0	100 / 137

Note: Contact factory for hermetic package and low cost surface mount package.

Wireless Amplifiers (MPS, ULA and WPS WiMax)

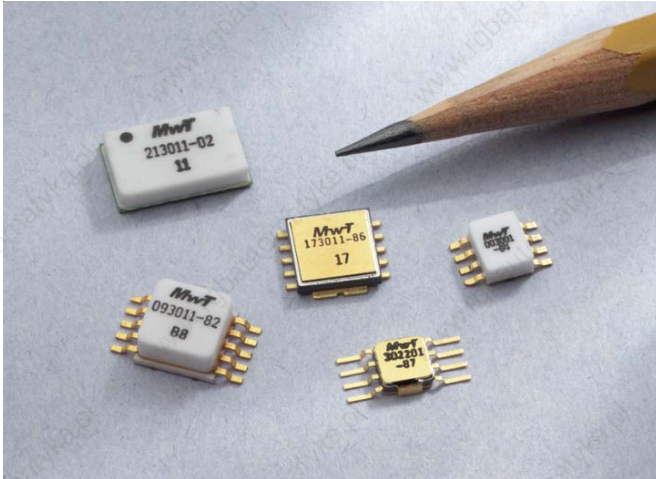

MwT Standard Broad Band General Purpose Amplifiers

Model (Case Code - > New	Case Code (- XX) Sealed SMT, Flange Leadless	Case Code (- XX) Hermetic SMT	Freq Range MHz	Linear Gain Typ/Min dB	Gain ± Flatness Typ/Max dB	VSWR: Input Typ dB	VSWR: 1 Output Typ dB	Noise Figure Typ/Max dB	Pout @ -1 dB Typ/Min dBm	PAE @ -1 dB Typ %	IP3 Typ/Min dBm	DC Voltage Applied V	DC Current Typ/Max mA
MPS 003001-XX	84, -	87	20-3000	11.5/10.5	0.80/1.20	1.6	1.6	4.0* / -	21.0 / 19.0	30*	34.0/-	5.0	90 / 160
MPS 302201-XX	-	87	100-3000	11.5/10.5	0.50/0.80	1.6	1.6	3.5*/5.0*	22.0 / 20.5	30	35.0/-	5.0	90 / 160
MPS 013001-XX	84, -	-	100-3000	11.5/10.5	0.80/1.20	1.6	1.6	3.5*/5.0*	21.0 / 19.0	30	34.0/-	5.0	90 / 160
MPS 082508-XX	82, 85	96	800-2500	13.0/11.0	0.50/1.00	2.0	2.0	5.0 / -	27.0 / 26.0	25	38.0/36.0	12.0	200 / 300
MPS 082509-XX	82, 85	96	800-2500	12.0/10.0	0.50/1.00	2.0	2.0	5.0 / -	25.5 / 23.0	25	36.0/-	10.0	135 / 200
> MPS-0425A9D-82	82	96	400-2500	14.0/13.0	0.50/0.80	1.4	1.2	-	25.0 / 24.0	-	42.0/40.0	7.5	220 / 280
> MPS-032701A-82	82	96	300-2700	20.0	1.0/-	2.0	2	5.0 / -	20.0 / 19.0	-	34.0/-	5.0	320-360

WPS - WiMax Amplifiers

Model #	Case Code Sealed	Case Code Hermetic	Freq Range	Linear Gain	Gain +/- Flatness	VSWR In	VSWR Out	P1dB	IP3	DC Voltage	DC Current
WPS-252717-XX	82	-	2500-2700	13.0/-	0.30/0.60	1.5	2.5	28.5	45	7.5	300
WPS-252724-XX	02,99	-	2500-2700	14.0/-	0.30/0.60	1.5	2.5	36.0	50	8.5	1200
MPS-343717-XX	82	-	3400-3700	13.0/-	0.30/0.60	1.5	2.5	29.0	45	7.5	380-450
MPS-343617-XX	82	-	3400-3600	13.0/-	0.30/0.60	1.5	2.5	29.0	48	7.5	380-450
MPS-363817-XX	82	-	3600-3800	13.0/-	0.30/0.60	1.5	2.5	29.0	48	7.5	380-450
WPS-343722-XX	02	-	3400-3700	13.0/-	0.30/0.60	1.5	2.5	32.0	47	8.0	600
WPS-343724-XX	02,99	-	3400-3700	14.0/-	0.30/0.60	1.5	2.5	36.0	50	8.0	1200
WPS-495917-XX	02	-	4900-5900	13.0/-	0.30/0.60	1.5	2.5	28.5	44	7.5	300
WPS-495922-XX	02	-	4900-5900	11.0/-	0.30/0.60	1.5	2.5	32.0	47	7.5	600

Optically Isolated Solid State Relays



The **OptoMOS** line of Solid State Relays uses discrete semiconductor components and the patented OptoMOS architecture to deliver fast, reliable, bounce-free switching in a compact design. From the world's smallest single-pole, high-voltage, 4-pin relay to multi-pole and multifunction devices, OptoMOS products are an ideal solid state replacement for larger reed and electromechanical relays. Compared to older electromagnetic technologies, the Clare OptoMOS relays offer significantly lower drive current, small package size, no susceptibility to magnetic interference and solid-state reliability. All of these are key requirements for the design of today's

complex low-power, multichannel products.

The small single pole 4-pin SOP relays combine our state-of-the-art, double-molded, vertical-construction packaging with high performance to give you a reliable product with 20% savings in board space compared to other 4-pin products.

Dual pole OptoMOS relays combine two independent relays into a single 8-pin package paving the way for designers to condense functionality using a single component. Common input OptoMOS relays provide a design alternative where two independent outputs are driven by the same input signal.

Features

- Low drive current
- High reliability
- No EMI/RFI generation
- Arc-free with no snubbing circuits
- Machine insertable, wave solderable
- AC/DC switching
- Current limiting (available)
- FCC compatible
- Low off state leakage

Applications

- Telecommunications/Datacommunications
- Instrumentation
- Multiplexers
- Data acquisition/Electronic switching
- I/O subsystems
- Meters (watt-hour, water, gas)
- Medical equipment (patient/equipment isolation)
- Security
- Aerospace
- Industrial controls



Single Pole Normally Open: 1-Form-A - Operational temperature range of -40° to 85°C

Part Number	Load Voltage V	Load Current mA	On Resistance Ω	Input Control Current mA	Switching Speeds T _{ON} /T _{OFF} ms	Isolation Voltage V _{rms}	Package Type ①	Features	
CPC1008N	100	150	8	2	2 / 0.5	1500	4-Pin SMT		
CPC1016N	100	100	16	2	2 / 0.5	1500	4-Pin SMT		
CPC1017N	60	100	16	1	10 / 10	1500	4-Pin SMT	NEW	
CPC1018N	60	600	0.8	2	2 / 1	1500	4-Pin SMT		
CPC1025N	400	120	30	2	2 / 1	1500	4-Pin SMT		
CPC1030N	350	120	30	2	2 / 1	1500	4-Pin SMT	Supplementary Isolation	
CPC1035N	350	100	35	2	2 / 1	1500	4-Pin SMT		
CPC1230N	350	120	30	2	2 / 1	1500	4-Pin SMT		
CPC1330	350	120	30	2	2 / 1	5000	4-Pin SMT, TH		NEW
CPC1335P	350	100	35	1	10 / 10	3750	8-Pin SMT		NEW
CPC1390	400	140	22	2	1 / 0.5	5000	4-Pin SMT, TH		NEW
CPC1393	600	100	50	5	5 / 5	5000	4-Pin SMT, TH	NEW	
CPC1510	250	200	15	5	2 / 2	3750	6-Pin SMT, TH	NEW Active Current Limit + Thermal Shutdown	
LCA100	350	120	25	5	5 / 5	3750	6-Pin SMT, TH	Current Limit	
LCA100L	350	120	25	5	5 / 5	3750	6-Pin SMT, TH		
LCA110	350	120	35	2	3 / 3	3750	6-Pin SMT, TH	Current Limit	
LCA110L	350	120	35	2	3 / 3	3750	6-Pin SMT, TH		
LCA120	250	170	20	5	5 / 5	3750	6-Pin SMT, TH	Current Limit	
LCA120L	250	150	20	5	3 / 3	3750	6-Pin SMT, TH		
LCA125	350	170	16	5	5 / 5	3750	6-Pin SMT, TH	Current Limit	
LCA125L	350	170	20	5	5 / 5	3750	6-Pin SMT, TH		
LCA126	250	170	15	5	5 / 5	3750	6-Pin SMT, TH	Current Limit	
LCA127	250	200	10	5	5 / 5	3750	6-Pin SMT, TH		
LCA127L	250	170	15	5	5 / 5	3750	6-Pin SMT, TH		
LCA129	250	170	20	2	8 / 8	3750	6-Pin SMT, TH		
LCA710	60	1000	0.5	10	2.5 / 0.25	3750	6-Pin SMT, TH		Low Off State Leakage 10nA High Load Current
LCA712	60	1000	0.5	10	2.5 / 0.5	3750	6-Pin SMT, TH		
LCA715	60	1800	0.25	10	5 / 2	3750	6-Pin SMT, TH		
LCA182	350	120	35	0.25	3 / 3	3750	6-Pin SMT, TH	Ultra Low Input Control Current	

① For Package Type, SMT indicates Surface Mount Technology while TH indicates Through-hole.

Optically Isolated Solid State Relays

Single Pole Normally Open: 1-Form-A - Operational temperature range of -40° to 85°C

Part Number	Load Voltage V	Load Current mA	On Resistance Ω	Input Control Current mA	Switching Speeds T_{ON}/T_{OFF} ms	Isolation Voltage V_{rms}	Package Type ①	Features
OMA160	250	50	100	10	0.125/0.125	3750	6-Pin SMT, TH	Low Off State Leakage 25nA
PLA110	400	150	22	5	1 / 0.25	3750	6-Pin SMT, TH	Current Limit
PLA110L	400	150	25	5	1 / 0.25	3750	6-Pin SMT, TH	
PLA132	50	600	1	5	5 / 2	3750	6-Pin SMT, TH	
PLA134	100	350	3	5	5 / 5	3750	6-Pin SMT, TH	
PLA140	400	250	8	5	3 / 1	3750	6-Pin SMT, TH	Current Limit
PLA140L	400	170	13	5	5 / 3	3750	6-Pin SMT, TH	
PLA143	600	100	50	5	5 / 5	4000	6-Pin SMT, TH	
PLA150	250	250	7	5	2.5 / 0.5	3750	6-Pin SMT, TH	
PLA160	300	50	100	10	0.05 / 0.05	3750	6-Pin SMT, TH	Low Off State Leakage 25nA
PLA170	800	100	50	5	5 / 5	3750	6-Pin SMT, TH	
PLA190	400	150	22	5	1 / 0.25	5000	6-Pin SMT, TH	
PLA191	400	250	8	5	1.5 / 0.25	5000	6-Pin SMT, TH	
PLA192	600	150	22	5	5 / 5	5000	6-Pin SMT, TH	
PLA193	600	100	50	5	5 / 5	5000	6-Pin SMT, TH	
XCA170	350	100	50	5	5 / 5	3750	6-Pin SMT, TH	

① For Package Type, SMT indicates Surface Mount Technology while TH indicates Through-hole.

Block diagrams

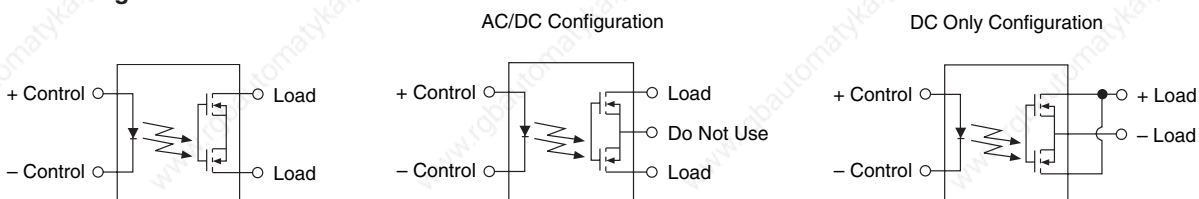

Single Pole Normally Open: 1-Form-A DC-Only - Operational temperature range of -40° to 85°C

Part Number	Load Voltage V	Load Current mA	On Resistance Ω	Input Control Current mA	Switching Speeds T_{ON}/T_{OFF} ms	Isolation Voltage V_{rms}	Package Type ①	Features
CPC1002N	60	700	0.55	2	5 / 2	1500	4-Pin SMT	
CPC1004N	100	300	4	2	3 / 1	1500	4-Pin SMT	Operat. Temperature to +110°C

Block diagram

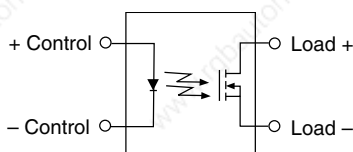

Single Pole Normally Open: 1-Form-A Voltage Controlled - Operational temperature range of -40° to 85°C

Part Number	Load Voltage V	Load Current mA	On Resistance Ω	Input Control Current mA	Switching Speeds T_{ON}/T_{OFF} ms	Isolation Voltage V_{rms}	Package Type	Features
CPC1218Y	60	600	0.8	5-12	5 / 5	2500	4-Pin SIP	NEW - Reed Relay Replacement

Block diagram

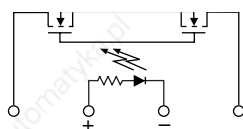

NEW



Optically Isolated Solid State Relays

Dual Independent Single Pole Normally Open: Dual 1-Form-A

Operational temperature range of -40° to 85°C

Part Number	Load Voltage	Load Current	On Resistance	Input Control Current	Switching Speeds	Isolation Voltage	Package Type	Features
	V	mA	Ω	mA	T _{ON} /T _{OFF} ms	V _{rms}		
LAA100	350	120	25	5	5 / 5	3750	8-Pin SMT, TH	Current Limit
LAA100L	350	120	25	5	5 / 5	3750	8-Pin SMT, TH	
LAA110	350	120	35	5	3 / 3	3750	8-Pin SMT, TH	Current Limit
LAA110L	350	120	35	5	3 / 3	3750	8-Pin SMT, TH	
LAA120	250	170	20	5	5 / 5	3750	8-Pin SMT, TH	Current Limit
LAA120L	250	150	25	5	5 / 5	3750	8-Pin SMT, TH	
LAA125	350	170	16	5	5 / 5	3750	8-Pin SMT, TH	Current Limit
LAA125L	350	150	20	5	5 / 5	3750	8-Pin SMT, TH	
LAA126	250	170	15	5	5 / 5	3750	8-Pin SMT, TH	Current Limit
LAA126L	250	170	20	5	5 / 5	3750	8-Pin SMT, TH	
LAA127	250	200	10	5	5 / 5	3750	8-Pin SMT, TH	Current Limit
LAA127L	250	170	15	5	5 / 5	3750	8-Pin SMT, TH	
LAA710	60	1000	0.5	10	2.5 / 0.25	3750	8-Pin SMT, TH	
OAA160	250	50	100	3	0.125 / 0.125	3750	8-Pin SMT, TH	Low Off State Leakage 25nA
PAA110	400	150	22	5	1 / 0.25	3750	8-Pin SMT, TH	Current Limit
PAA110L	400	150	25	5	1 / 0.25	3750	8-Pin SMT, TH	
PAA132	50	600	25	5	5 / 2	3750	8-Pin SMT, TH	
PAA140	400	250	8	5	1.5 / 0.25	3750	8-Pin SMT, TH	Current Limit
PAA140L	400	200	13	5	5 / 3	3750	8-Pin SMT, TH	
PAA150	250	250	7	5	2.5 / 0.5	3750	8-Pin SMT, TH	
PAA190	400	150	22	5	1 / 0.5	5000	8-Pin SMT, TH	
PAA191	400	250	8	5	3 / 1	5000	8-Pin SMT, TH	
PAA193	600	100	50	5	5 / 5	5000	8-Pin SMT, TH	
XAA170	350	100	50	5	5 / 5	3750	8-Pin SMT, TH	

① For Package Type, SMT indicates Surface Mount Technology while TH indicates Through-hole.

Block diagram

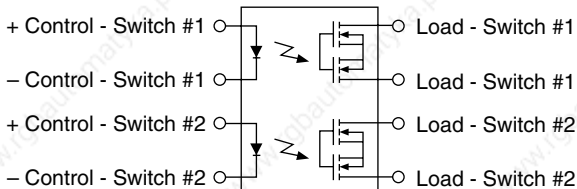

Common Input, Dual Pole: 2-Form-A

Operational temperature range of -40° to 85°C

Part Number	Load Voltage	Load Current	On Resistance	Input Control Current	Switching Speeds	Isolation Voltage	Package Type	Features
	V	mA	Ω	mA	T _{ON} /T _{OFF} ms	V _{rms}		
LCA210	350	85	35	8	3 / 3	3750	8-Pin SMT, TH	Current Limit
LCA210L	350	100	35	5	4 / 4	3750	8-Pin SMT, TH	
LCA211	350	85	35	8	1 / 1.2	3750	8-Pin SMT, TH	
LCA220	250	120	20	10	5 / 5	3750	8-Pin SMT, TH	

① For Package Type, SMT indicates Surface Mount Technology while TH indicates Through-hole.

Block diagram

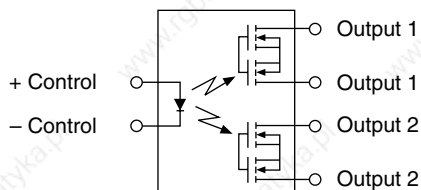

Optically Isolated Solid State Relays

Single Pole Normally Closed: 1-Form-B - Operational temperature range of -40° to 85°C

Part Number	Load Voltage V	Load Current mA	On Resistance Ω	Input Control Current mA	Switching Speeds T_{ON}/T_{OFF} ms	Isolation Voltage V_{rms}	Package Type ①	Features
CPC1117N	60	150	16	1	1 / 2	1500	4-Pin SMT	Supplementary Isolation
CPC1130N	350	120	30	2	2 / 2	1500	4-Pin SMT	
CPC1135N	350	120	35	1	2 / 2	1500	4-Pin SMT	
CPC1150N	350	120	50	2	1 / 2	1500	4-Pin SMT	
CPC1231N	350	120	30	2	2 / 2	1500	4-Pin SMT	
LCB110	350	120	35	5	3 / 3	3750	6-Pin SMT, TH	
LCB111	350	120	35	2	5 / 5	3750	6-Pin SMT, TH	
LCB120	250	170	20	5	5 / 5	3750	6-Pin SMT, TH	
LCB126	250	170	15	5	5 / 5	3750	6-Pin SMT, TH	
LCB127	250	200	10	5	5 / 5	3750	6-Pin SMT, TH	
PLB150	250	250	7	5	1 / 2.5	3750	6-Pin SMT, TH	

① For Package Type, SMT indicates Surface Mount Technology while TH indicates Through-hole.

Block diagram

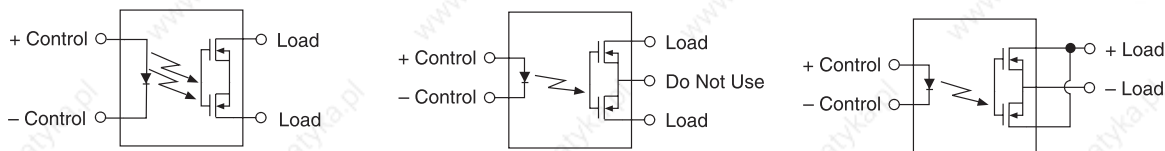

Dual Independent Single Pole Normally Closed: 2-Form-B - Operational temperature range of -40° to 85°C

Part Number	Load Voltage V	Load Current mA	On Resistance Ω	Input Control Current mA	Switching Speeds T_{ON}/T_{OFF} ms	Isolation Voltage V_{rms}	Package Type ①
LBB110	350	120	35	5	3 / 3	3750	8-Pin SMT, TH
LBB120	250	170	20	5	5 / 5	3750	8-Pin SMT, TH
LBB126	250	170	15	5	5 / 5	3750	8-Pin SMT, TH
LBB127	250	200	10	5	5 / 5	3750	8-Pin SMT, TH
PBB150	250	250	7	5	2.5 / 2.5	3750	8-Pin SMT, TH
XBB170	350	100	50	5	5 / 5	3750	8-Pin SMT, TH

① For Package Type, SMT indicates Surface Mount Technology while TH indicates Through-hole.

Block diagram

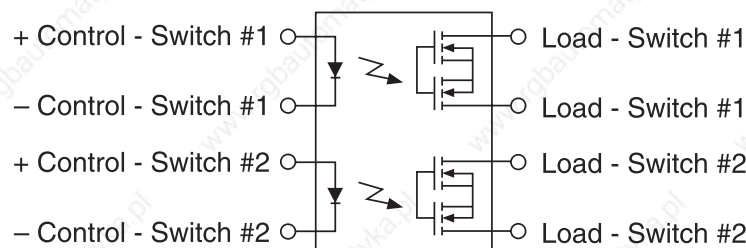

Optically Isolated Solid State Relays

Dual Pole Combination: Form-A & B - Operational temperature range of -40° to 85°C

Part Number	Load Voltage V	Load Current mA	On Resistance Ω	Input Control Current mA	Switching Speeds T_{ON}/T_{OFF} ms	Isolation Voltage V_{rms}	Package Type ①	Features
LBA110	350	120	35	5	3 / 3	3750	8-Pin SMT, TH	Current Limit
LBA110L	350	120	35	5	3 / 3	3750	8-Pin SMT, TH	
LBA120	250	170	20	5	5 / 5	3750	8-Pin SMT, TH	Current Limit
LBA120L	250	150	25	5	5 / 5	3750	8-Pin SMT, TH	
LBA126	250	170	15	5	5 / 5	3750	8-Pin SMT, TH	Current Limit
LBA126L	250	150	20	5	5 / 5	3750	8-Pin SMT, TH	
LBA127	250	200	10	5	5 / 5	3750	8-Pin SMT, TH	Current Limit
LBA127L	250	150	15	5	5 / 5	3750	8-Pin SMT, TH	
PBA150	250	250	7	5	2.5 / 2.5	3750	8-Pin SMT, TH	
XBA170	350	100	50	5	5 / 5	3750	8-Pin SMT, TH	

① For Package Type, SMT indicates Surface Mount Technology while TH indicates Through-hole.

Block diagram

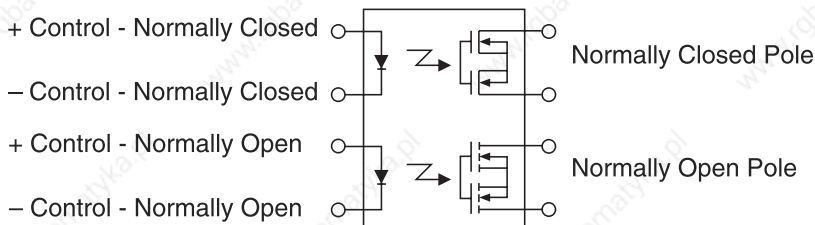

Common Input: 1-Form-C - Operational temperature range of -40° to 85°C

Part Number	Load Voltage V	Load Current mA	On Resistance Ω	Input Control Current mA	Switching Speeds T_{ON}/T_{OFF} ms	Isolation Voltage V_{rms}	Package Type ①
LCC110	350	120	35	8	4 / 4	3750	8-Pin SMT, TH
LCC120	250	170	20	10	5 / 5	3750	8-Pin SMT, TH

① For Package Type, SMT indicates Surface Mount Technology while TH indicates Through-hole.

Block diagram

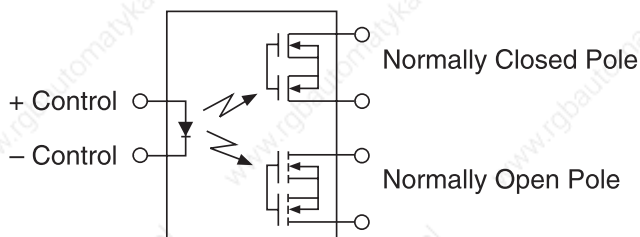

Optically Isolated AC-Power Switches

The OptoMOS line of power products use dual power SCR outputs to produce an alternative to optocoupler and Triac circuits. These AC- Power Switches are robust enough to provide a blocking voltage of up to 800V_P. In addition, tightly controlled zero-cross circuitry ensures switching of AC loads without the generation of transients. The input and output

circuits are optically coupled to provide 3750V_{rms} of isolation and noise immunity between control and load circuits. Long life and environmental integrity make these power switches ideal to control a variety of AC circuits in industrial environments where electromagnetic interference would disrupt the operation of electromechanical relays.

Features

- Load current up to 2 A
- Blocking voltage up to 800 V_P
- 5m A sensitivity
- Zero-crossing detection
- DC control, AC switching
- Optically isolated I/O
- TTL and CMOS compatible
- Low EMI and RFI generation
- High noise immunity
- VDE compatible
- Machine insertable, wave solderable
- Switching speed < 0.5 cycle

Applications

- Programmable controls
- Process control
- Power control panels
- Remote switching
- Gas pump electronics
- Contactors
- Large relay control circuits
- Solenoids
- Motor controls
- Heater controls

Operational temperature range of -40° to 85°C

Part Number	Blocking Voltage V _P	Load Current A _{rms}	Operating Frequency min/max Hz	Input Control Current mA	Isolation Voltage V _{rms}	Package Type	Features
CPC1943G	240	0.5	20 / 400	5	3750	D, E	
CPC1945G	400	1	20 / 400	5	3750	C	
CPC1945Y	400	1	20 / 400	5	3750	A	
CPC1961G	600	0.2	20 / 400	5	3750	F, G	NEW Dual
CPC1962G	600	0.3	20 / 500	5	3750	D, E	NEW
CPC1963G	600	0.5	20 / 500	5	3750	D, E	
CPC1965G	600	1	20 / 400	5	3750	C	
CPC1965Y	600	1	20 / 400	5	3750	A	
CPC1972G	800	0.25	20 / 500	5	3750	D, E	NEW
CPC1976Y	600	2	20 / 500	5	3750	B	NEW
PD1201	400	1	20 / 500	5	3750	C	
PD2401	500	1	20 / 500	5	3750	C	
PD2601	600	1	20 / 500	5	3750	C	
PM1204	400	0.5	20 / 500	5	3750	D, E	
PM1205	500	0.5	20 / 500	5	3750	D, E	
PM1206	600	0.5	20 / 500	5	3750	D, E	
PS1201	400	1	20 / 500	5	3750	A	
PS2401	500	1	20 / 500	5	3750	A	
PS2601	600	1	20 / 500	5	3750	A	

Block Diagram

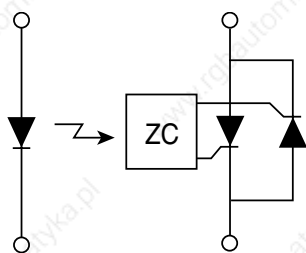

Power Solid State Relays

(Power dissipation greater than 1 Watt)

Power SIP, ISOPLUS™-264 and i4-PAC™ Relays



Clare and IXYS have joined forces to bring OptoMos technology, reliability and compact size to the new Power SIP, i4-PAC and ISOPLUS-264 series of power solid state relays. Development of these new products was founded on the blending of Clare's traditional strengths in the design and manufacture of photovoltaic integrated circuits (ICs), lead-frame design and multichip packaging with IXYS' expertise in power MOSFETs, power packages and substrate technology.

The optically coupled MOSFET technology provides 2500V_{rms} of input to output isolation. Similar to Clare's solid state relays, the optically coupled output is controlled by a GaAIAs infrared LED.

Clare Power Relays are now offered in three package types: the **Power SIP**, the **i4-PAC**, and the **ISOPLUS-264**. The Power SIP package offers pin-to-pin compatibility with other solid state relays providing an easy upgrade path for existing designs and compatibility for new designs.

The i4-PAC and the ISOPLUS-264 packages feature a unique assembly process whereby the silicon is soft soldered onto a Direct Copper Bond (DCB) substrate rather than traditional bonding onto an epoxy encapsulated copper frame. This structure allows for a substantially lower junction-to-case thermal impedance when compared to conventionally assembled power relays. The i4-PAC thermal resistance is 0.35°C/W while the ISOPLUS-264 has an even lower impedance of 0.30°C/W.

Although exposed on the backside of these packages, the electrically non-conductive surface of the DCB ceramic substrate provides 2500V_{rms} of isolation to the package's electrically conductive power switching and control leads.

The combination of an electrically isolated non-conductive exterior and low thermal impedance makes the new i4-PAC and ISOPLUS-264 power relays an ideal solution for power applications preferring a non-biased heat sink with superior thermal management properties.

Features

- Handles loads up to 9A
- Voltage ratings up to 1000V_p
- Low On-resistance
- Non-conductive thermal pad for heat sink applications
- Industry standard 4-Pin SIP package
- Low input control current
- Low thermal impedances:
0.30°C/W - ISOPLUS-264
0.35°C/W - i4-PAC
1.5°C/W - Power SIP

Applications

- Motor controls
- Robotics
- Medical equipment
- Railroad/traffic controls
- Consumer appliances
- Industrial control
- Test and measurement equipment

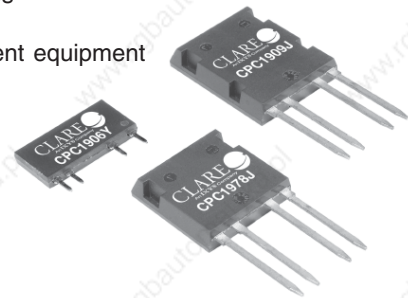

Specifications for: AC/DC Single Pole Power SIP, ISOPLUS-264 and i4-PAC Relays

Part Number	Blocking Voltage V _p	Load Current (Free Air) A _{rms}	On Resistance Ω	Switching Speeds T _{ON} /T _{OFF} ms	Input Control Current mA	Isolation Voltage V _{rms}	Package
CPC1906Y	60	2	0.3	10 / 5	10	2500	Power SIP
CPC1908J	60	3.5	0.3	20 / 5	10	2500	i4-PAC
CPC1909J	60	6.5	0.1	25 / 10	10	2500	ISOPLUS-264
CPC1916Y	100	2.5	0.34	5 / 3	10	2500	Power SIP
CPC1918J	100	5.25	0.1	25 / 10	10	2500	ISOPLUS-264
CPC1926Y	250	0.7	1.4	10 / 10	10	2500	Power SIP
CPC1967J	400	1.35	0.6	20 / 5	10	2500	i4-PAC
CPC1973Y	400	0.35	5	5 / 3	10	2500	Power SIP
CPC1977J	600	1.25	1	20 / 5	10	2500	i4-PAC
CPC1978J	800	0.9	2.3	20 / 5	10	2500	i4-PAC
CPC1979J	600	1.5	0.75	25 / 5	10	2500	ISOPLUS-264
CPC1981Y	1000	0.18	18	10 / 5	10	2500	Power SIP
CPC1986J	1000	0.7	3	20 / 5	10	2500	i4-PAC
CPC1988J	1000	0.9	2.5	20 / 5	10	2500	ISOPLUS-264

Block Diagram

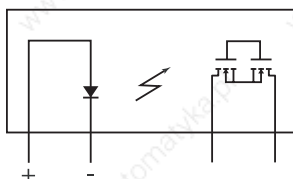

Power Solid State Relays

Specifications for: DC-only Single Pole i4-PAC Relays

Part Number ▶ New	Blocking Voltage V	Load Current (Free Air) A	On Resistance Ω	Switching Speeds T_{ON}/T_{OFF} ms	Input Control Current mA	Isolation Voltage V _{rms}	Package
▶ CPC1708J	60	4	0.08	20 / 5	10	2500	i4-PAC
▶ CPC1709J	60	9	0.025	20 / 5	10	2500	ISOPLUS-264
CPC1777J	600	1.5	0.5	20 / 5	10	2500	i4-PAC
CPC1786J	1000	0.65	2	20 / 5	10	2500	i4-PAC

Block Diagram

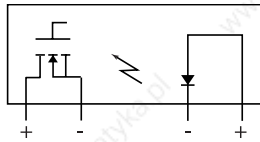

Package Dimensions

Power SIP

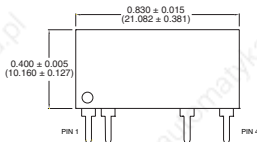

i4-PAC™

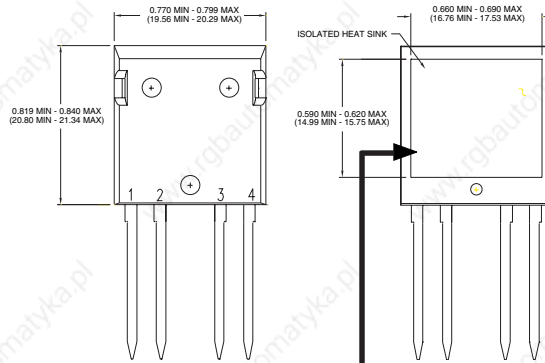

ISOPLUS264

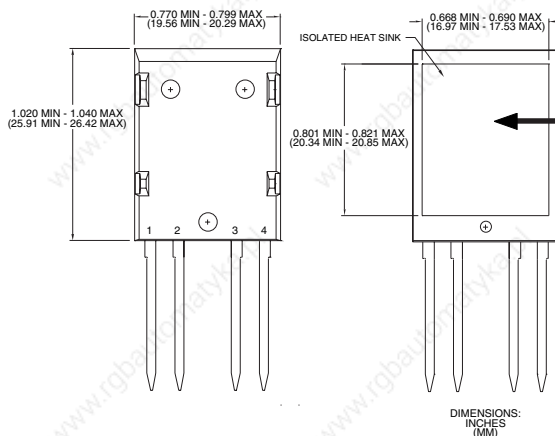

Non-conductive thermal pad

Dimensions:
inches
(mm)

OptoMOS Linear Optocouplers feature an infrared LED optically coupled to a pair of phototransistors. One feedback (input) phototransistor is used to generate a control signal that provides a servomechanism to the LED drive current thus compensating for the LEDs nonlinear time and temperature characteristics. The output phototransistor provides an isolated output signal that is linear with respect to the servo LED current.

OptoMOS Linear Isolation Amplifiers integrate a linear optocoupler with two independent LF356 op-amps in a single 16-pin package. These amplifiers can couple both AC and DC signals in either uni-polar or bi-polar modes, while providing 3750V_{rms} of input/output isolation. Using a servo control loop to compensate for the nonlinear time and temperature characteristics of the LED, these amplifiers distinguish themselves among conventional optocouplers by significantly improving linearity and stability.

Features

- Couples analog and digital signals
- 3750V_{rms} input/output isolation
- Wide bandwidth (>200kHz)
- High gain stability
- Low input/output capacitance
- Low power consumption
- 0.01% servo linearity
- THD 87dB typical
- Machine insertable, wave solderable
- VDE compatible

Applications

- Modem transformer replacement with no insertion loss
- Digital telephone isolation
- Power supply feedback voltage/current
- Medical sensor interfacing
- Isolation of process control transducers



Operational temperature range of -40° to 85°C

Part Number	Servo Gain K1	Forward Gain K2	Transfer Gain K3	Input Control Current mA	Isolation Voltage V _{rms}	Package ¹ Type
LOC110	0.004 / 0.03	0.004 / 0.03	0.55 / 1.43	2	3750	8-Pin SMT, TH
LOC111	0.008 / 0.03	0.006 / 0.03	0.733 / 1.072	2	3750	8-Pin SMT, TH
LOC112	0.004 / 0.03	0.004 / 0.03	0.55 / 1.43	2	3750	8-Pin SMT, TH
LOC210P	0.004 / 0.03	0.004 / 0.03	0.733 / 1.072	2	3750	16-Pin SMT
LOC211P	0.008 / 0.03	0.006 / 0.03	0.733 / 1.072	2	3750	16-Pin SMT
LIA100	0.004 / 0.03	0.004 / 0.03	0.55 / 1.43	2	3750	16-Pin SMT
LIA101	0.004 / 0.03	0.004 / 0.03	0.733 / 1.072	2	3750	16-Pin SMT

¹ For Package Type, SMT indicates Surface Mount Technology while TH indicates Through-hole.

Block Diagrams

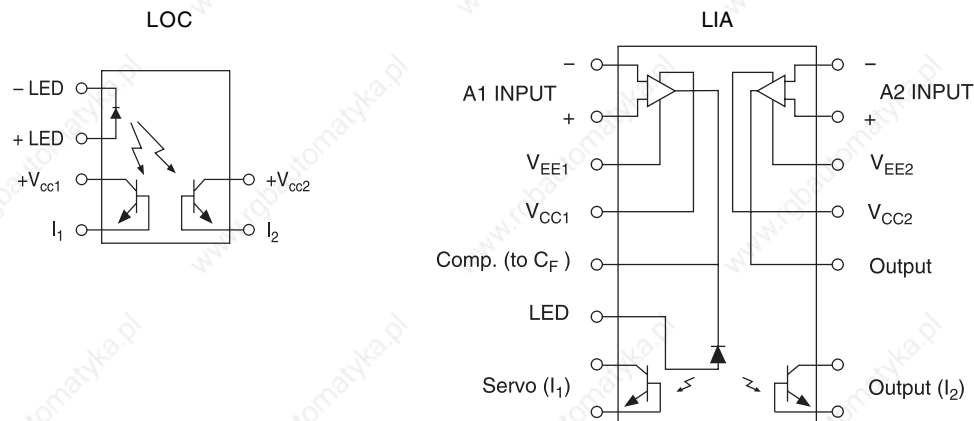

Optically Isolated Error Amplifiers

Optically Isolated Linear Error Amplifiers combine Clare's optical technology with an industry standard 431-type precision programmable shunt regulator to provide linear isolated feedback for power supply designs. The LIA120 features matched photodiodes for linear high-gain response exhibiting excellent temperature stability for a total gain error of less than 2 dB.

These devices are well suited for isolated high-gain feedback amplifiers that require excellent linearity and low temperature variation such as power supply feedback stages, modem and audio transformer replacements, industrial control signals, and sensor feedback.

Features

- Fully Matched IC
- 70dB Linearity (typ.)
- Optocoupler, precision reference and error amplifier in single package
- Low voltage operation 2.7V

Applications

- Power supply feedback
- Telecom central office supply
- Telecom bricks
- Modem transformer replacement



Operational temperature range of -40° to 85°C

Part Number	Reference Voltage	V _{REF} Tolerance	CTR K1	CTR K2	CTR Matching K3	Linearity	Isolation Voltage V _{rms}	Package ¹ Type
LIA120	1.24V	2%	1 to 3%	1 to 3%	85 to 115%	70dB	3750	NEW - 8-Pin SMT, TH
LIA130	1.24V	2%	-	-	-	-	3750	NEW - 8-Pin SMT, TH

¹ For Package Type, SMT indicates Surface Mount Technology while TH indicates Through-hole.

Block Diagrams

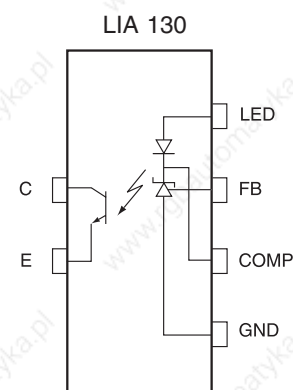
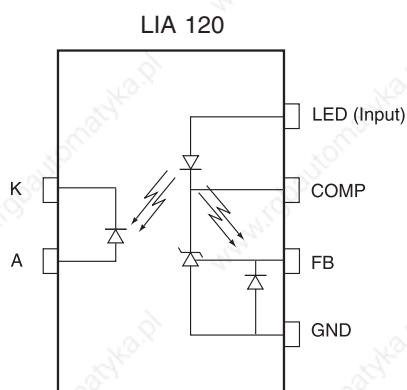

Single and Dual Optocouplers

Single and dual OptoMOS products provide an optically isolated means of current detection or control of switching circuits. Devices offer a single or dual antiparallel LED input stage for unidirectional or bidirectional signal control to the optically coupled phototransistor output. The phototransistor output can be either a single transistor or, for greater gain, a darlington transistor.

These optocouplers allow for either AC or DC input circuits and are ideal for telecom, industrial control and instrumentation circuits where electrical isolation of control circuitry is crucial.

Features

- AC and DC compatible inputs
- 3750V_{rms} input/output isolation
- Machine insertable, wave solderable



Applications

- Telecom switching
- Tip/ring circuits
- Modem switching (laptops, notebooks, PDAs)
- Loop detection
- Ringing detection
- Current sensing



Operational temperature range of -40° to 85°C

Part Number	Breakdown Voltage	Nominal Current Transfer Ratio	Saturation Voltage	Input Control Current	Isolation Voltage	Package ¹ Type	Configuration
	V						
LDA100	20	100	0.5	6	3750	6-Pin SMT, TH	A
LDA101	20	100	0.5	6	3750	6-Pin SMT, TH	B
LDA110	20	1000	0.8	2	3750	6-Pin SMT, TH	C
LDA111	20	1000	0.8	2	3750	6-Pin SMT, TH	D
LDA200	20	100	0.5	6	3750	8-Pin SMT, TH	E
LDA201	20	100	0.5	6	3750	8-Pin SMT, TH	F
LDA202	20	100	0.5	6	3750	8-Pin SMT, TH	NEW E
LDA203	20	100	0.5	6	3750	8-Pin SMT, TH	NEW F
LDA210	20	1000	0.8	2	3750	8-Pin SMT, TH	G
LDA211	20	1000	0.8	2	3750	8-Pin SMT, TH	H
LDA212	20	1000	0.8	2	3750	8-Pin SMT, TH	NEW G
LDA213	20	1000	0.8	2	3750	8-Pin SMT, TH	NEW H

¹ For Package Type, SMT indicates Surface Mount Technology while TH indicates Through-hole.

Block Diagrams

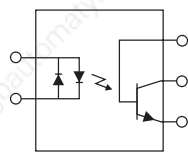

A

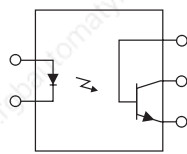

B

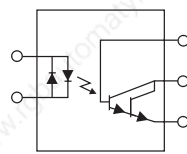

C

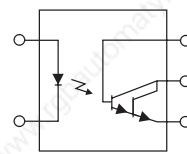

D

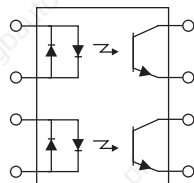

E

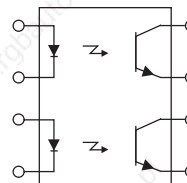

F

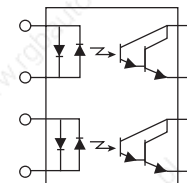

G

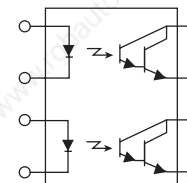

H

Multifunction Products

The **OptoMOS** line of Multifunction products combines optically-isolated discrete component functions into a single package. These products mix and match solid-state relays, optocouplers, bridge rectifiers, Darlington transistors and zener diodes to

create highly functional circuits in a single, small package. Multifunction devices allow designers to consolidate circuit functions into a single device, freeing up valuable board space and reducing component count.

Features

- 3750V_{rms} input to output isolation
- Multiple functionality in single package
- Current limiting (part numbers with L suffix)
- Machine insertable, wave solderable
- TTL and CMOS compatible

Applications

- Telecommunication/Datacommunication
- Instrumentation
- I/O subsystems
- Electronic switching
- Medical equipment (patient/equipment isolation)
- Security
- Aerospace
- Industrial controls



Combination SSR & Optocoupler Products (IAx, IBx, TS, XS) - Operational temperature range of -40° to 85°C

Part Number	Relay Parameters			Optocoupler Parameters					Isolation Voltage V _{rms}	Package ¹ Type	Features
	Load Voltage V _p	Current Handling mA	On Resistance Ω	Input Control Current mA	Break-down Voltage V	Current Transfer Ratio %	Saturation Voltage V	Input Control Current mA			
IAA110P	350	100	35	5	20	33	0.5	6	3750	16-Pin SMT	
IAA170P	350	100	50	5	20	33	0.5	6	3750	16-Pin SMT	
IAB110P	350	100	35	5	20	33	0.5	6	3750	16-Pin SMT	
IAD110P	350	100	35	5	20	33	0.5	6	3750	16-Pin SMT	
IAD170P	350	100	50	5	20	33	0.5	6	3750	16-Pin SMT	
IBB110P	350	100	35	5	20	33	0.5	6	3750	16-Pin SMT	
TS112N	350	120	20	2	20	100	0.5	6	1500	8-Pin SMT Narrow	
TS117	350	120	35	2	20	100	0.5	6	3750	8-Pin SMT, TH	
TS117L	350	120	35	2	20	100	0.5	6	3750	8-Pin SMT, TH	Current Limit
TS118	350	120	35	5	20	100	0.5	6	3750	8-Pin SMT, TH	Form B
TS120	350	120	35	5	20	1000	0.8	2	3750	8-Pin SMT, TH	
TS120L	350	120	35	5	20	1000	0.8	2	3750	8-Pin SMT	Current Limit
TS122	350	170	20	5	20	100	0.5	6	3750	8-Pin SMT, TH	
TS190	350	150	22	5	20	100	0.5	6	3750	8-Pin SMT, TH	
TS190L	350	150	25	5	20	100	0.5	6	3750	8-Pin SMT	Current Limit
XS170	350	120	50	2	20	100	0.5	6	3750	8-Pin SMT, TH	

¹ For Package Type, SMT indicates Surface Mount Technology while TH indicates Through-hole.

Block Diagrams

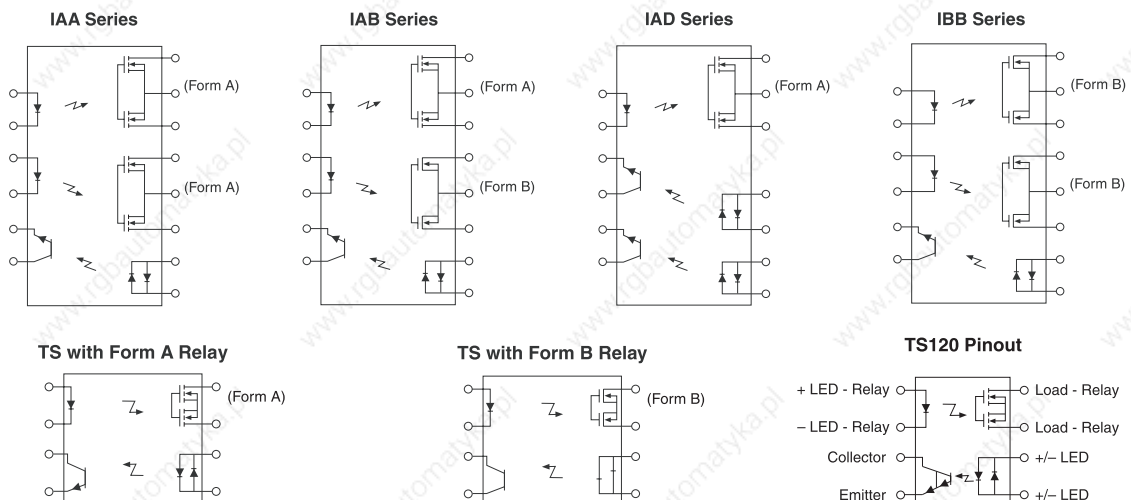

Designed specifically for the telecommunications industry, the Integrated Telecom Circuit (ITC) series is well suited for voice telephony and modem applications, providing most of the major

functions required when designing DAA (Data Access Arrangement) or voice (FXO) line interface circuits.



Telecom Series (ITC) - Operational temperature range of -40° to 85°C

Part Number	Relay Parameters			Octocoupler Parameters					Isolation Voltage V_{rms}	Package ¹ Type	Features
	Load Voltage V_P	Load Current mA	On Resistance Ω	Input Control Current mA	Break-down Voltage V	Current Transfer Ratio %	Saturation Voltage V	Input Control Current mA			
ITC117P	350	120	15	5	20	33	0.5	6	3750	16-Pin SMT	
ITC117PL	350	120	15	5	20	33	0.5	6	3750	16-Pin SMT	Current Limit
ITC135P	350	120	15	5	20	33	0.5	6	3750	16-Pin SMT	Half-wave ringing detect
ITC137P	350	120	15	5	20	33	0.5	6	3750	16-Pin SMT	Full-wave ringing detect

¹ For Package Type, SMT indicates Surface Mount Technology while TH indicates Through-hole.

Block Diagrams

No zener protection Bi-directional opto-input

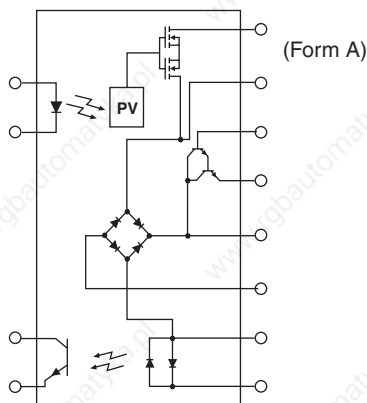

ITC117

Zener protection Bi-directional opto-input

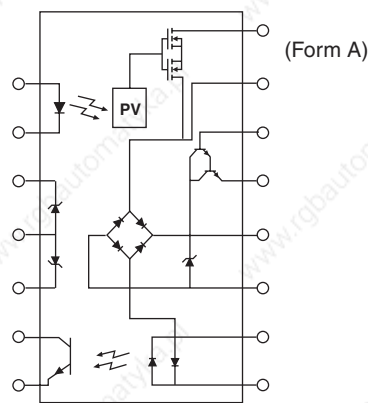

ITC137

Zener protection Uni-directional opto-input

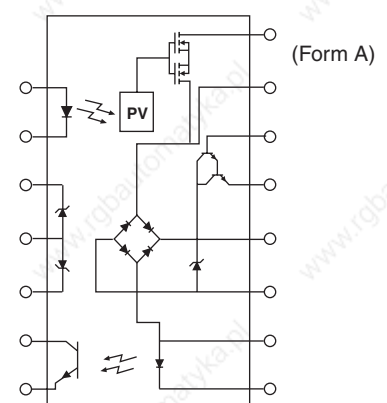

ITC135

xDSL/ISDN DC Termination ICs

The CPC1465 provides a polarity-insensitive DC termination for wetting (sealing) current on the CPE side conforming to ITU-T G.991.2 to eliminate corrosion on xDSL/ISDN lines. The CPC1465 has excellent linearity (70dB typ.) to minimize harmonic distortion and well-controlled turn-on and turn-off characteristics to minimize injecting impulse noise with in-band signal energy into the DSL channel.

This DC termination IC which interfaces with the tip/ring pair is rated at 300V and able to handle power cross and lightning transients with appropriate protection. Manufactured in Clare's proven 320V Silicon-On-Insulator (SOI) process, the CPC1465 is packaged in a 16 pin SOIC or MLP.

Features

- Meets wetting (sealing) current requirements per ITU-T G.991.2
- Integrated bridge rectifier for polarity correction
- Uses inexpensive opto-coupler for DC signalling
- Electronic inductor, breakover, and latch circuits
- Current limiting and excess power protection circuits
- ANSI SHDSL and ISDN compatible
- MLT and SARTS compatible
- Excellent linearity (70dB typ.)

Applications

- ADSL2+ compatible with appropriate inductor
- SHDSL
- ISDN
- Router and bridge customer premises equipment
- Leased line equipment
- T1/E1 network line cards and repeaters
- Network Termination 1 (NT1) equipment
- Mechanized Loop Test (MLT) networks
- Switched Access Remote Test System (SARTS) networks

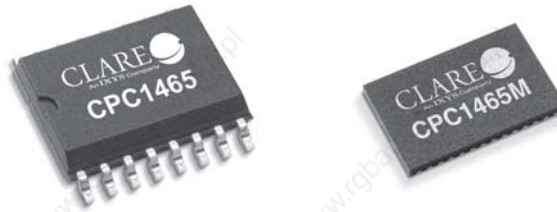

High-speed Line Interface Product

Part Number	Package
CPC1465D	16-pin SOIC
CPC1465M	NEW - 16-pin MLP

Block Diagrams

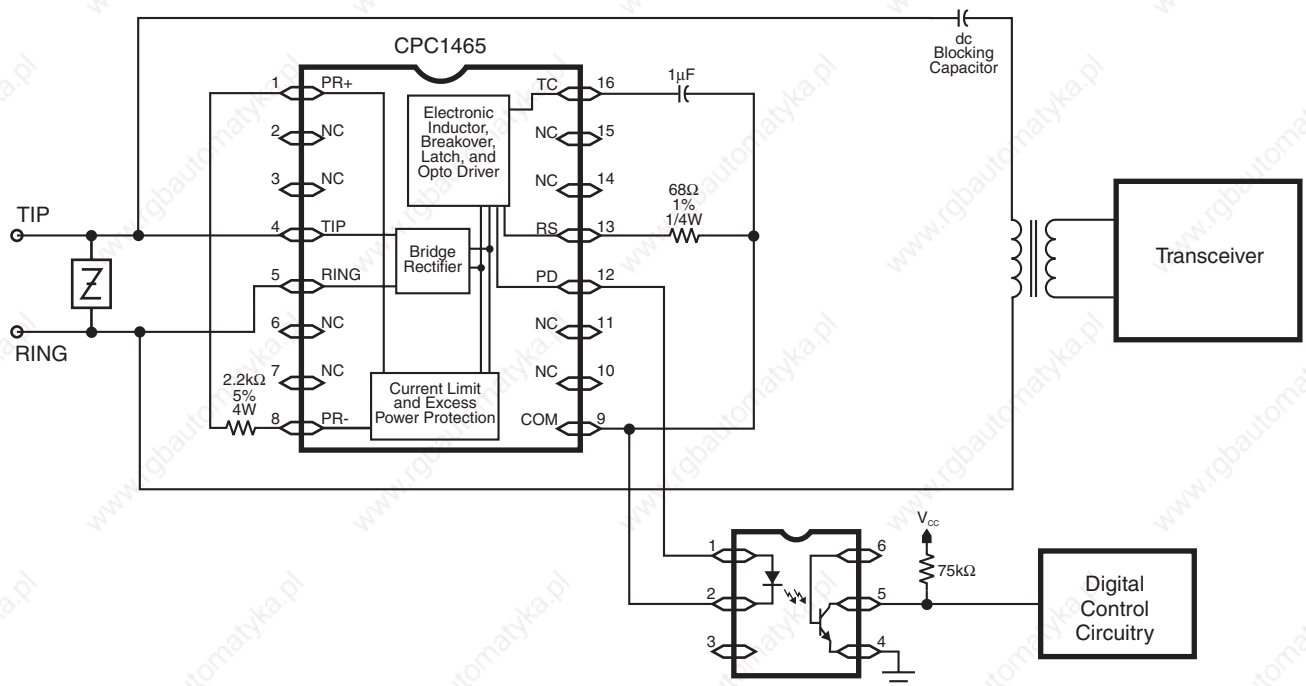

Line Card Access Switch (LCAS)



The Line Card Access Switch (LCAS) product family is an integral part of Clare's product portfolio for the telecommunications market. Clare's unique high-voltage Silicon-On-Insulator (SOI) process technology, manufactured in its state-of-the-art fab in Beverly, MA, provides the foundation for a multitude of silicon solutions that enable low power, high density line cards.

The LCAS product family consists of monolithic ICs that contain high-voltage switches for tip and ring line break, power ringing, line test access, test in access and ringing generator testing.

They provide the necessary functions to replace all 2-Form-C electromechanical relays found on both traditional voice and integrated voice and data (IVD) line cards found in Central Office, Digital Loop Carriers and Channel Banks. With the introduction of the next generation CPC759x family, Clare is poised to continue its leadership in high voltage switching applications. New features include:

- 1) TTL compatible inputs
- 2) Smart logic for safe power up and hot plug state control
- 3) Increased dv/dt immunity.



Features

- Small surface mount SOIC or Micro Leadframe Package (MLP)
- Monolithic IC reliability
- Low, matched on-resistance
- Built-in zero-cross switching
- Impulse noise reduction
- Current limiting, thermal shutdown and SLIC protection
- Robust power cross and lightning surge performance
- Ultra-low power consumption of <10.5 mW
- Pin-to-pin compatibility to the Legerity 7581, 7582, and 7583 SOIC products

Applications

- VOIP gateways
- Central Offices (CO)
- Digital Loop Carriers (DLC)
- Digitally Added Main Line (DAML)
- Hybrid Fiber Coax (HFC)
- Fiber in the Loop (FITL)
- Pair Gain systems
- Channel banks
- PBX systems

Part Number	Switching Pairs						Protection Features				Package Type	
	# Switches	Break	Ringing	Test Out	Test in	Ringing Test	Zero-Cross Switching	Diode Bridge	Protection SCR	Minimum Hold Current mA		Logic States
CPC7591xA	4	•	•				•	Half	•	110	3	16 SOIC or MLP
CPC7591xB	4	•	•				•	Full	•	110	3	
CPC7592xA	6	•	•	•			•	Half	•	60	4	16 SOIC or MLP
CPC7592xB	6	•	•	•			•	Full	•	60	4	
CPC7592xC	6	•	•	•			•	Half	•	110	5	
CPC7593xA	10	•	•	•	•	•	•	Half	•	110	7	20 or 28 SOIC or 28 MLP
CPC7593xB	10	•	•	•	•	•	•	Full	•	110	7	
CPC7593xC	10	•	•	•	•	•	•	Half	•	110	8	
CPC7593xD	10	•	•	•	•	•	•	Full	•	110	8	
CPC7594xA	6	•	•		•		•	Half	•	110	4	16 SOIC or MLP
CPC7594xB	6	•	•		•		•	Full	•	110	4	
CPC7594xC	6	•	•		•		•	Half	•	110	4	
CPC7581xA	4	•	•				•	Half	•	60	3	16 SOIC or MLP
CPC7581xB	4	•	•				•	Full	•	60	3	
CPC7581xC	4	•	•				•	Half	•	110	3	
CPC7582xA	6	•	•	•			•	Half	•	60	4	16 SOIC
CPC7582xB	6	•	•	•			•	Full	•	60	4	
CPC7582xC	6	•	•	•			•	Half	•	110	5	
CPC7583xA	10	•	•	•	•	•	•	Half	•	100	7	20 or 28 SOIC
CPC7583xB	10	•	•	•	•	•	•	Full	•	100	7	
CPC7583xC	10	•	•	•	•	•	•	Half	•	100	8	
CPC7583xD	10	•	•	•	•	•	•	Full	•	100	8	

Line Card Access Switch (LCAS) Micro Lead-frame Package (MLP) Products

With the introduction of the Micro Leadframe Package (MLP), the same functionality and performance now comes at a fraction of the size and makes 32 channel (or greater) line cards a reality. Even compared to fourth generation EMRs, these MLPs offer a dramatic area and height savings of 65% and 80% respectively.

All LCAS versions listed below are available in an MLP package. The last digit in the part number indicates the logic version and is the same for both the MLP and SOIC versions.

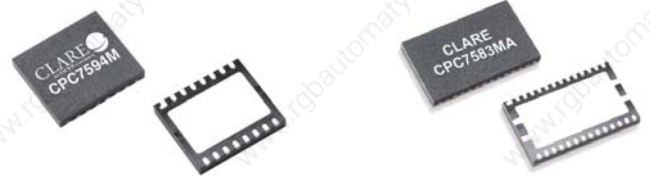

Part Number	Package	W mm	L mm	H mm	Area mm ²	# of EMRs LCAS replaces	Area Savings vs EMRs
CPC7591Mx	16MLP	6	7	0.9	42	1	43%
CPC7592Mx	16MLP	6	7	0.9	42	2	71%
CPC7593Mx	28MLP	7	11	0.9	77	3	65%
CPC7594Mx	16MLP	6	7	0.9	42	2	71%

Block Diagram

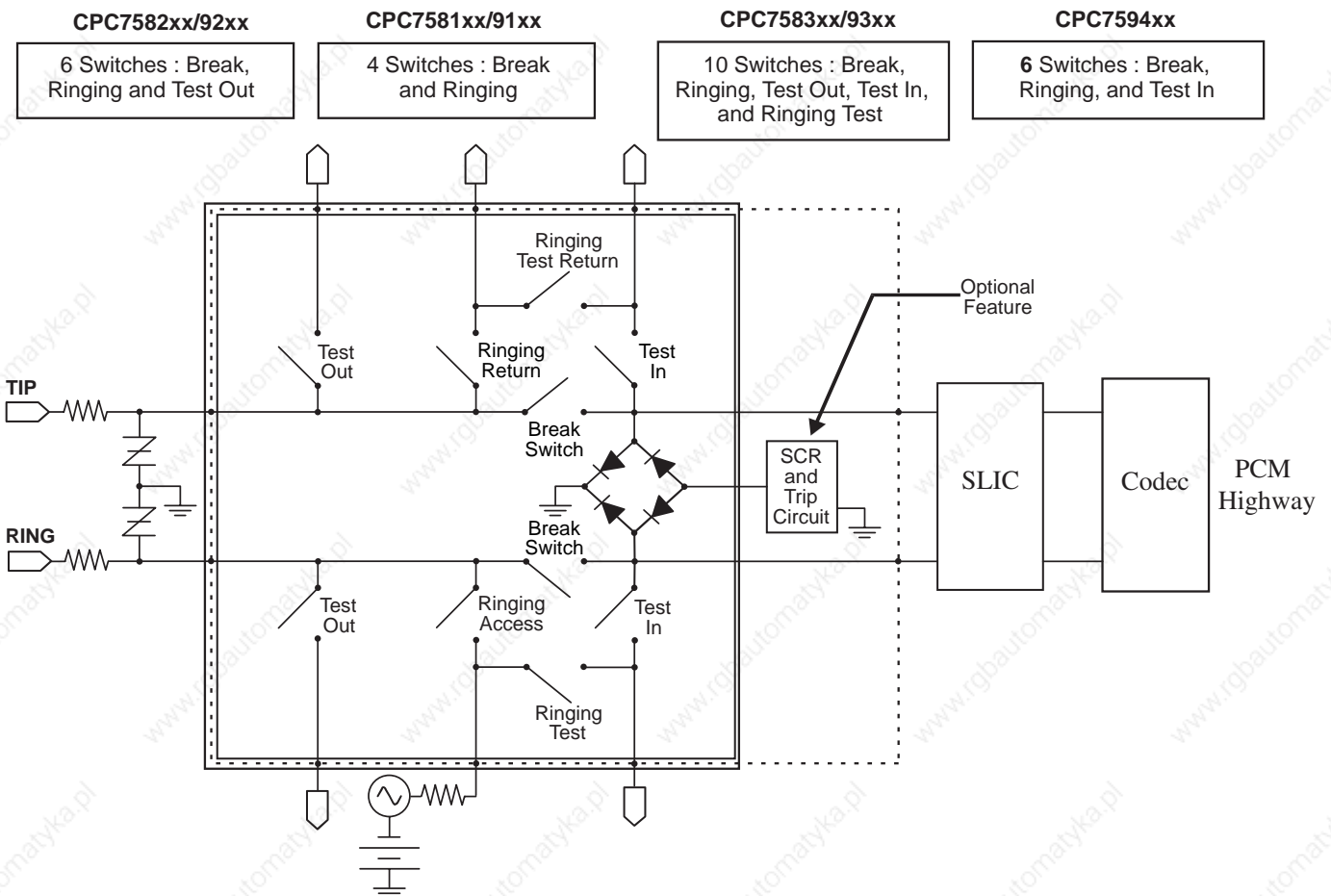

LITELINK™ Silicon DAA, Phone Line Interface



The LITELINK phone line interface is the industry's only single package silicon Data Access Arrangement, featuring a 32-pin, small outline, low profile, surface mount package. It is ideal for both voice and data (V.22bis to V.90/V.92) and applications in particularly dense circuit environments. The internal optical isolation barrier eliminates high cost transformer or capacitive isolation circuits. This solution saves cost relative to competitive circuits through reduced passive component count and smaller printed-circuit board space.

The 3kV_{rms} internal isolation barrier exceeds all worldwide regulatory requirements. The optical isolation barrier yields low distortion performance necessary for high speed communications. In addition, the LITELINK application circuit is capable of surviving 6kV (10usec x 700usec) lightning surge waveforms making it the most robust silicon DAA on the market.

LITELINK offers the lowest operational phone line quiescent current. The device easily interfaces to commonly available

standard single-ended or differential voice and modem codecs on the market. Contact Clare for information on codec reference designs that offer programmable AC termination impedance for global applications. LITELINK complies with international PSTN agency requirements.

The newest device is the CPC5622 which is part of the LITELINK III product family. It offers continuous Caller-ID (CID) signal reception which is ideal for telephony applications in countries where CID information is present before the ringing signal. The CPC5622 also offers both full and half wave ringing signal detection allowing the designer to chose the appropriate interface to the codec/DSP block.

Features

- Voice and data applications
- Modem DAA for speeds up to V.92
- Half-wave or full-wave ringing detection
- Worldwide telephone network compatibility
- Caller-ID reception
- Line side powered from telephone line
- 3.3 V to 5 V power supply
- Easy interface with modem ICs and voice CODECs
- High power transmit option for voice applications (>3 dBm)

Applications

- Computer telephony
- VoIP gateways
- PBXs
- Satellite set-top box
- V.92 modems
- Fax machines
- Voice mail systems
- Embedded modems
- Vending machines
- Automated banking
- Remote metering
- Surveillance
- Security systems



Part Number	Family	Isolation Voltage V _{rms}	Power Supply	MODE pin	Caller ID	Ringing Detect	Status
CPC5622	LITELINK III	3000	3.3V to 5V	Yes	Continuous	Half & Full wave	Recommended for New Designs
CPC5621	LITELINK III	3000	3.3V to 5V	Yes	Selectable	Full wave	Recommended for New Designs
CPC5620	LITELINK III	3000	3.3V to 5V	Yes	Selectable	Half wave	Recommended for New Designs
CPC5611	LITELINK II	1500	3.3V to 5V	No	Selectable	Full wave	
CPC5610	LITELINK II	1500	3.3V to 5V	No	Selectable	Half wave	
CPC5604	LITELINK I	1500	5V	No	Selectable	Half wave	

NOTE: For the CPC5603 and CPC5602 detail, please see "FETs, N-Channel Depletion Mode" section on page 30.

CPC5622 LITELINK III Block Diagram CPC5622 LITELINK III Reference Design Schematic

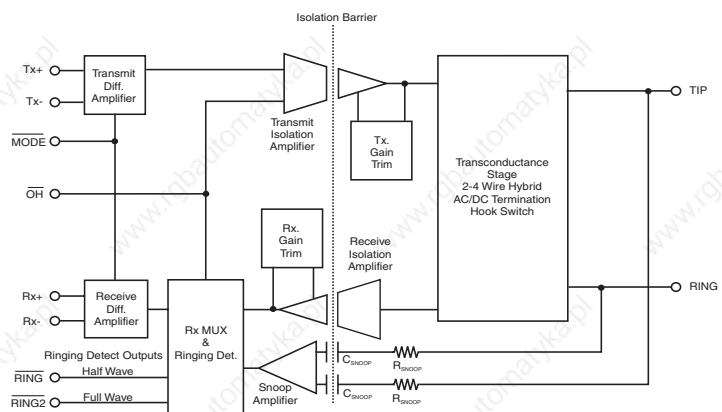

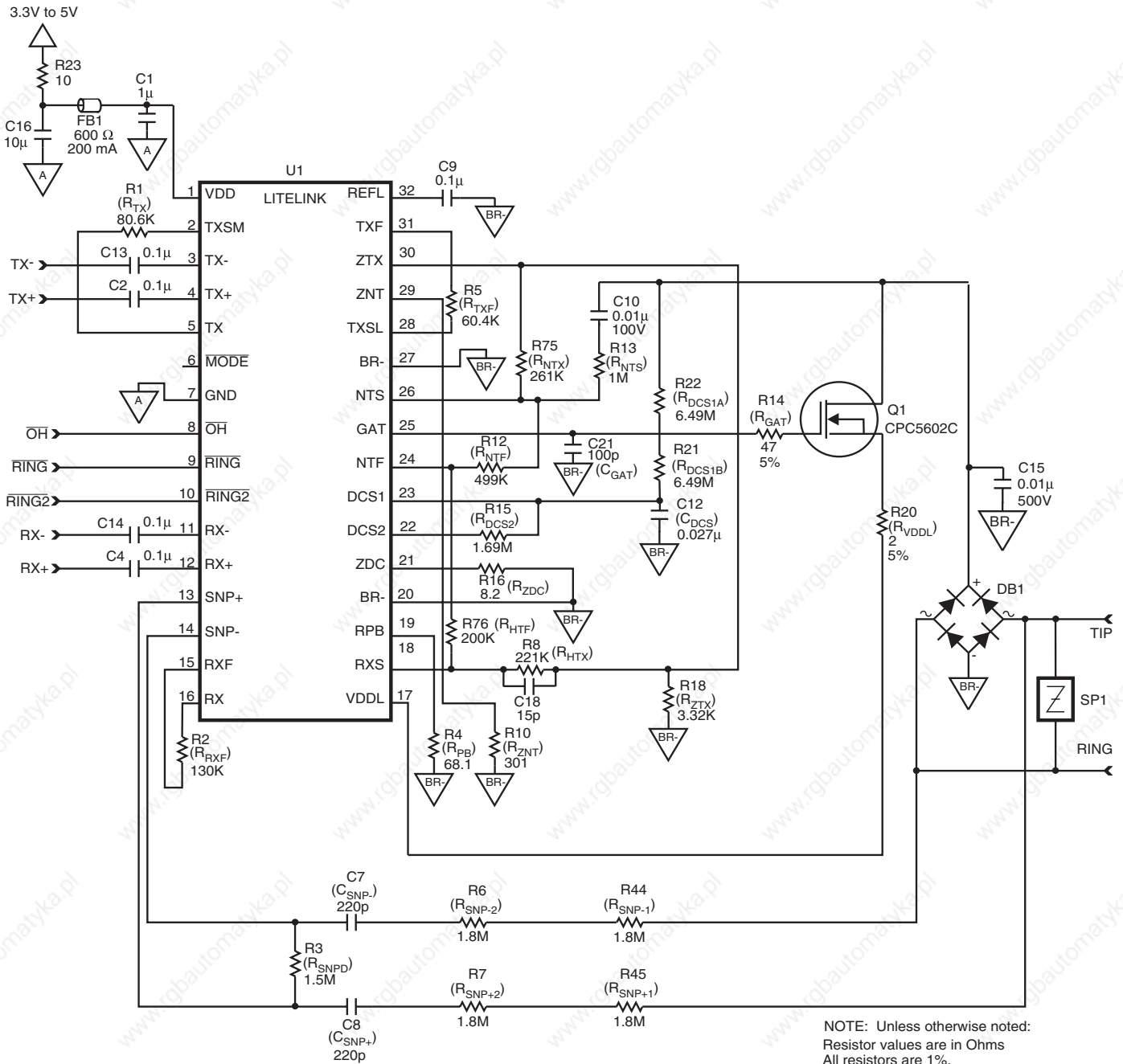

Phone Line Monitor

Clare's CPC5710N 8-pin SOIC is a versatile building block for designing telephone line monitoring circuits. High common-mode rejection ratio (>40 dB) and high input impedance makes the CPC5710N an excellent choice for tip/ring voltage monitoring, battery presence detection, line-in-use detection (another-phone-off-hook), polarity reversal, display feature (Caller ID) signal reception, ringing detection and discrete voice recording.

The CPC5710N high impedance input circuit eliminates phone line monitoring discrete components that reduce central office (CO) battery voltage to Customer Premise Equipment (CPE)

equipment. This allows the CPE equipment to work properly on long phone loops and meet difficult worldwide regulatory low CO voltage conditions. The high impedance resistive barrier application circuit is fully compliant to the EN60950 safety standard and meets the ITU-T K.21 over voltage and over current specifications. Common applications include telephony gateways, IP-PBX, computer telephony, embedded modems, set-top boxes, voice recording applications, and point-of-sale equipment.

Features

- Excellent common-mode rejection ratio (CMRR), >40 dB
- Supplied application circuits meet EN60950 Safety and ITU-T K.21 specification isolation requirements
- High input impedance circuit eliminates line voltage drop for better performance and compliance to worldwide specifications
- Small 8-pin SOIC
- Worldwide telephone network compatibility
- Full-wave ringing level detector comparator with internal threshold, large hysteresis, and logic-level output
- 3.3 V to 5 V operation
- High differential input impedance with very low common mode input impedance
- Fixed gain
- Differential or single-ended linear output
- TTL logic input
- CMOS logic output (TTL compatible)
- Virtually non-detectable in voice monitoring

Applications

In monitoring applications the CPC5710N can be used for:

- Display feature (caller ID) signal processing
- Line-in-use detection (another phone-off-hook)
- Ringing signal level detection
- Battery presence monitoring
- Tip and ring lead voltage monitoring
- Line polarity



Part Number	Power Supply
CPC5710	3.3V to 5V

APOH and Polarity Detection Application Circuit

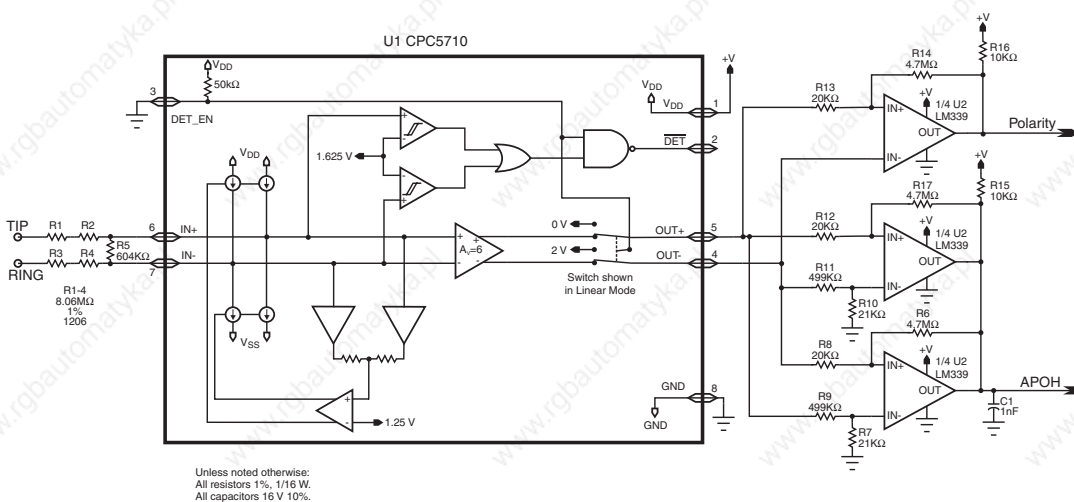

FETs, N-Channel Depletion Mode

Clare's N-channel depletion mode Field Effect Transistors (FETs) utilize a proprietary third generation vertical DMOS process. The third generation process realizes world class, high voltage MOSFET performance in an economical silicon gate process. The vertical DMOS process yields a robust device for high power applications with high input impedance. These highly reliable FET devices have been used extensively in Clare's solid state relays for industrial and telecommunications applications.

The normally-on MOSFETs are well suited for low cost, pre-regulator applications that are tolerant of high voltage drop and power dissipation between the power source and the output regulator stage. The pre-regulator is particularly effective as an inexpensive solution for filtering AC line voltage variations in non-isolated DC power supplies as compared to switch mode power supplies or step down transformers.



Part Number	BV_{DSX} V	$R_{DS(ON)}$ Max Ω	$V_{GS(off)}$ Min V	$V_{GS(off)}$ Max V	I_{DSS} @ $V_{GS} = 0V$ Min mA	Package
CPC3703	250	4	-1.6	-3.9	300	SOT-89
CPC3710	250	10	-1.6	-3.9	220	SOT-89
CPC3714	350	14	-1.6	-3.9	240	SOT-89
CPC3720	350	22	-1.6	-3.9	130	SOT-89
CPC3730	350	30	-1.6	-3.9	140	SOT-89
CPC5602	350	14	-2.0	-3.6	130	SOT-223
CPC5603	415	14	-2.0	-3.6	130	SOT-223

Application - Pre-regulator Non-isolated Power Supply with Depletion Mode FET

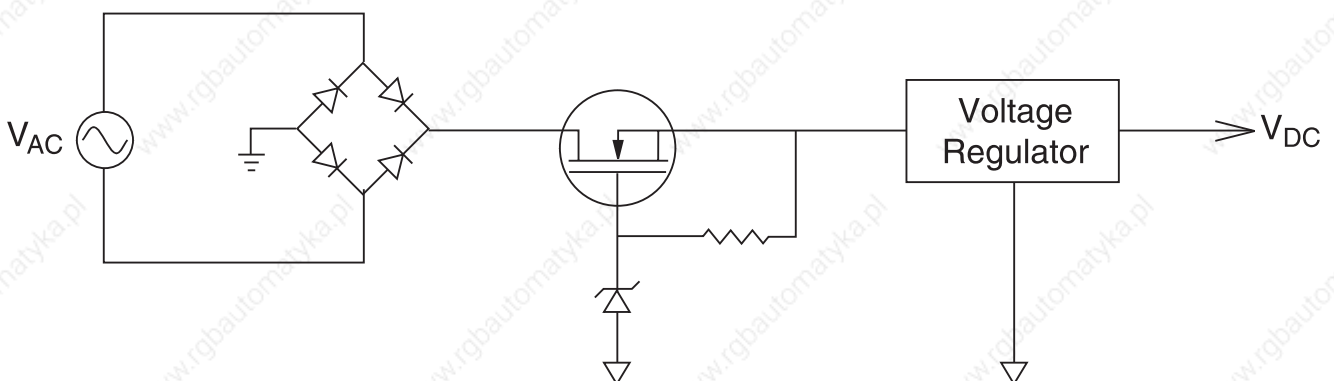

Data Access Arrangement (DAA) Modules

The Cybergate family is Clare's turnkey modular DAA solution. The V.34 family provides the circuitry required in a single, completely functional DAA circuit in a 1.07" x 1.07" x 0.4" plastic module. This plug-and-play design allows the user to choose the necessary options to minimize costs, and in turn, maximize

value. Standard features include surge protection, transient protection zeners, ringing detection, hook-switch circuitry, gyrator circuitry (impedance balancing) and a transformer. Caller-ID (CID) and loop current detection are also available as options.

Features

- 28.8kbps (except for CYG2911 at 9.6kbps)
- Optional caller ID and loop current sense
- Ringing detection
- Low power hookswitch
- Surge protection
- Low THD
- Gyrator circuitry
- Meets most regulatory agency requirements

Applications

- Modems
- Remote data acquisition
- Fax machines
- Security/metering
- Computer telephony
- PBX
- Voice mail systems



Cybergate Data Access Arrangements

Part Number	Region	Hook Switch Resistance	DC Loop Current	Return Loss (min.)	Insertion Loss (max.) TX-Transmit RX-Receive	Ringing Voltage Detection Range	Isolation Voltage	Features						
								Full Wave	Half Wave	Caller-ID	Loop Current Detect	911 Emergency	2-4 Wire Conversion	
														Ω
CYG2000	N. America Asia	15	20-120	18	Tx 7 Rx 7	20-150	1000		•					
CYG2001	N. America Asia	15	20-120	18	Tx 7 Rx 7	20-150	1000	•						
CYG2010	N. America Asia	15	20-120	18	Tx 7 Rx 7	20-150	1000		•		•			
CYG2011	N. America Asia	15	20-120	18	Tx 7 Rx 7	20-150	1000	•			•			
CYG2020	N. America Asia	15	20-120	18	Tx 7 Rx 7	20-150	1000		•	•				
CYG2021	N. America Asia	15	20-120	18	Tx 7 Rx 7	20-150	1000	•		•				
CYG2030	N. America Asia	15	20-120	18	Tx 7 Rx 7	20-150	1000		•	•	•			
CYG2031	N. America Asia	15	20-120	18	Tx 7 Rx 7	20-150	1000	•		•	•			
CYG2100	Europe	35	5-120	14	Tx 7 Rx 7	29-150	1500		•					
CYG2110	France	35	5-120	14	Tx 7 Rx 7	29-150	1500		•					
CYG2111	CTR-21	35	5-120	14	Tx 7.5 Rx 7.5	29-150	1500		•					
CYG2120	Spain	35	5-120	14	Tx 7 Rx 7	28-150	1500		•					
CYG2217	N. America Asia	15	20-120	39	Tx 7 Rx 1	20-150	1000		•					•
CYG2218	N. America Asia	15	20-120	39	Tx 1 Rx 1	20-150	1000		•					•
CYG2300	Germany	-	5-120	14	Tx 7 Rx 7	29 MIN	1500		•					
CYG2320	Australia	-	5-120	14	Tx 7 Rx 7	29 MIN	1500		•					
CYG2911	N. America Asia	15	20-120	18	Tx 9 Rx 9	20-150	1000		•	•		•		

*All of the parts listed are in a DIP package, operate using a 5V power supply, have a minimum On-hook impedance of 10 M Ω , Maximum Total Harmonic Distortion (THD) of 0.01% and a tip to ring surge protection voltage of 300V.

Embedded Modem Module (EMM)

The Embedded Modem Module combines a datapump and microcontroller with the Data Access Arrangement (DAA) to deliver an all-in-one solution for V.22bis modem transaction-oriented applications. This plug-and-play module provides a total solution complete with transferable FCC registration. It

supports a standard serial V.24 TTL interface to the DTE equipment. The CPC2400E features a quick handshake time of 1.6 seconds. This offers a clear advantage for short connection sessions when compared to V.34 and V.90 modems which have a data handshake period greater than 10 seconds.

Features

- Easy integration and installation
- Small footprint of 1.00" x 2.50"
- Low power consumption
- 5V Power supply operation
- Supports V.22bis, V.22, V.23
- FCC part 15B compliant
- FCC part 68 user transferable registration
- UL Approved

Applications

- Point-of-Sale (POS)
- Gaming equipment
- Utility metering
- Lock boxes
- Remote monitoring
- Embedded applications
- Medical appliances

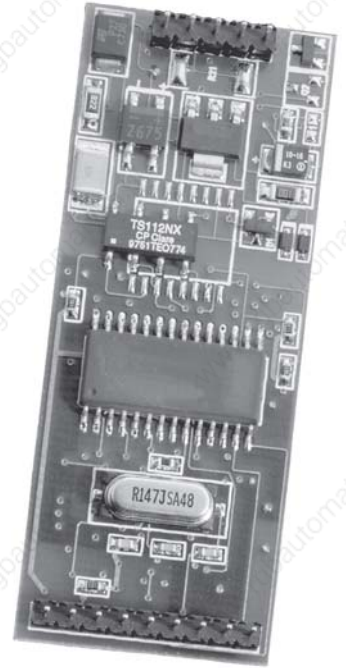

Block Diagram

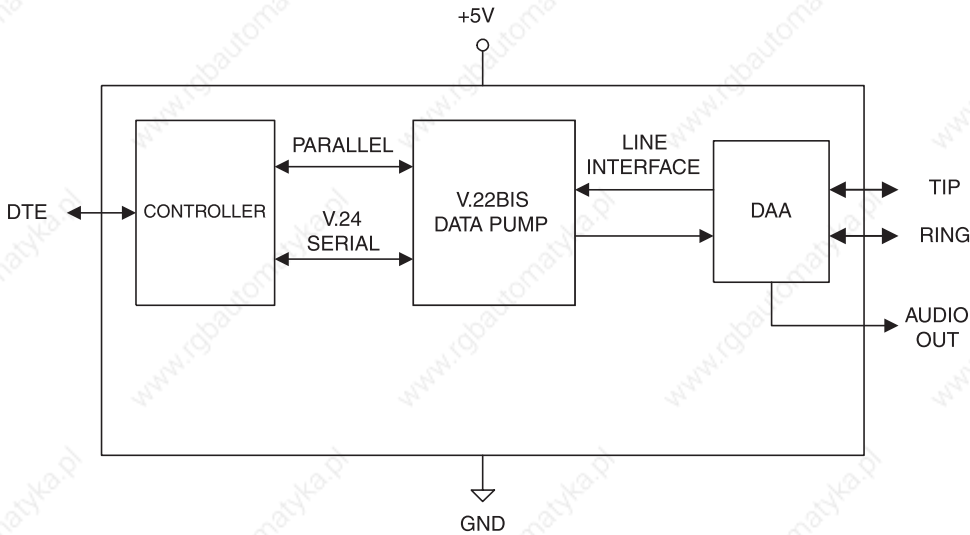

Pin Diagram

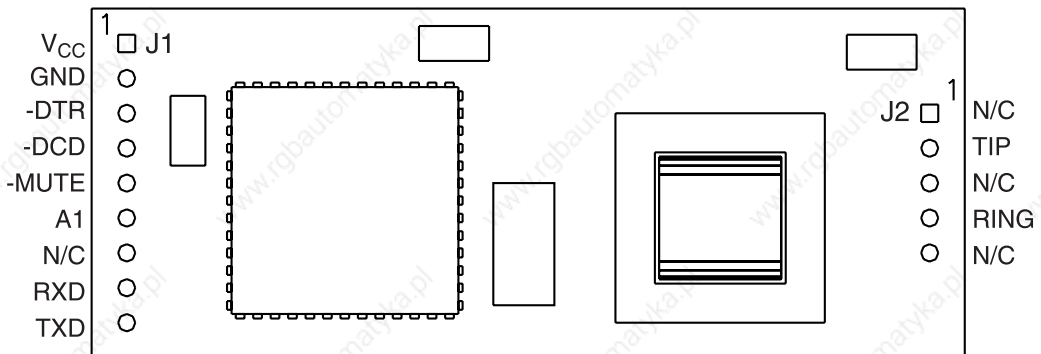

Tone Signaling Products include Dual Tone Multi-Frequency (DTMF) Receivers, MF Trunk Signaling ICs and Call Progress Detectors, and Generators and Hook Switch Status Devices.

Call Progress Detectors and Generators

Clare's family of Call Progress Detectors and Generators provides an inexpensive method of detecting and generating common call progress tones including busy tone, dial tone, call waiting tones and others. The family includes both an inexpensive band detector and precise call tone detectors that detect individual tones. Detectors are available in both DIP and

SOIC packages and operate on a 3 V to 5 V supply. The call progress generator allows for a simple method of providing dial tone busy tone and other call progress tones in applications where a POTS interface is required such as VoIP or other network gateways.

Features

- Receive and generate common call progress tones
- Detectors operate with a single 3V to 5V supply
- Linear input (detectors) and output (generator)
- Inexpensive band detector with wide dynamic range (>38dB)
- Low power consumption
- Detectors available for both common call progress and SIT tones
- Available in both DIP and SOIC packages

Applications

- PBX circuits
- Billing systems
- Test equipment
- Point of Sale terminals
- Pay telephones

Part Number	Function	Detection Frequencies				Special Information Tones (SIT)	Package Type
		Band	Dial Tone	Audible Ringing	Busy Tone		
	315-640Hz	350 + 440Hz	440 + 480Hz	480 + 620Hz			
M-980-02	Detector	•					8-Pin TH, 16-Pin SMT
M-982-02	Detector		•	•	•		22-Pin TH, 20-Pin SMT
M-984-02	Detector		•	•	•	•	14-Pin TH, 16-Pin SMT
M-985-01	Detector		•	•	•	•	22-Pin TH, 20-Pin SMT
M-991	Generator		•	•	•		14-Pin TH, 16-Pin SMT

Block Diagrams

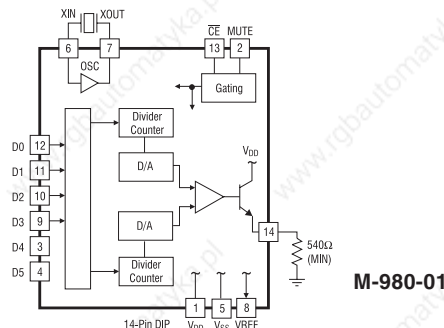
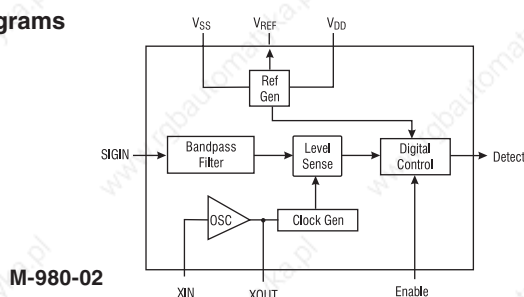

Hook Switch Status Devices

M-949-01 Line Sense Relay

- Senses telephone line current from 18 to 125 mA
- Used by control circuitry for on-hook/off-hook monitoring, switch hook flash detection and rotary dial pulse
- Provides 1500V_{DC} coil-to-contact isolation
- Includes 1-Form-A relay contact
- Applications include central office products, PBX and key systems, rotary dial monitoring devices

M-949-11 Balanced Dual Coil Telephone Line Current Sensing Relay

- Senses telephone line current from 15 to 200mA
- Used by control circuitry for on-hook/off-hook monitoring, switch hook flash detection and rotary dial pulse
- Meets high isolation voltage requirement of 4000V
- Meets UL and British Standard specifications
- Includes 1-Form-A relay contact

M-959 Dial Pulse Counter and Hook Status Monitor

- Independent hook status monitoring
- Time-guarded dial pulse counting
- 10 or 20 PPS dialing speeds pin selectable
- Valid data output strobe

Block Diagram

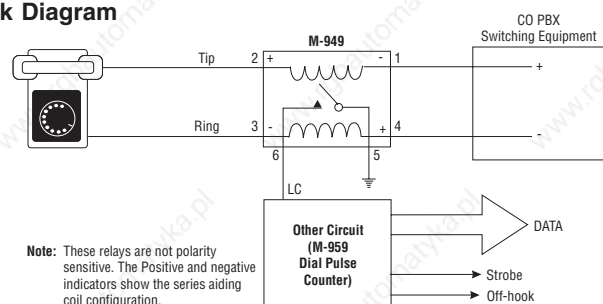

DTMF Receiver M8870

DTMF signaling is used in tone dialing applications where a direct inexpensive method of receiving DTMF digits is required. The M-8870-01 device uses an inexpensive color burst crystal.

Adjustable guard times provide flexibility for fast operation or additional accuracy in receiving DTMF dialing tones.

Features

- 5 Volt receivers
- Adjustable receiver guard time
- Central Office quality and performance

Applications

- PBX and Central Office tone receivers
- Security systems
- Credit card verification
- Fax machines
- Pay telephones
- Remote control
- Remote data entry

Block Diagram M 8870

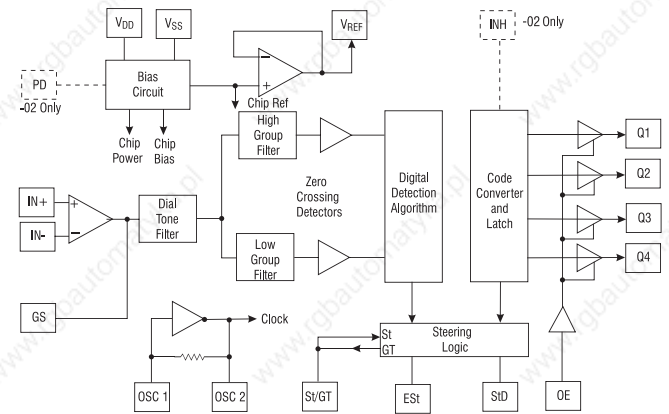

MF Trunk Signaling ICs

MF signaling ICs, available in a variety of formats, eliminate the need for additional software required to implement MF signaling protocols in trunk circuits. Used in MF trunk signaling applications, these products include a family of PCM digital MF transceivers in a variety of formats. Signaling formats include R1 (μ Law) and R2 (A Law) Specification.

The M-993 is a stand-alone generator and provides a simple inexpensive method of generating analog R1 MF signaling tones. Already used in thousands of systems worldwide, these products give the system designer a proven method of providing MF signaling capability.

Features

- Direct PCM interface to chip
- Manual or Compelled Mode operation for R2 Signaling
- 2.048 MHz clocking
- Dual Channel
- Microprocessor read/write interface
- R1 and R2 formats provided

Applications

- Trunk Circuits requiring MF trunk signaling in R1 or R2 signaling formats

Part Number	Function	CCITT R1	CCITT R2	A Law PCM	μ Law PCM	PCM in/Out	Analog out	PackageType
M-986-2A1P	Transceiver	•		•	•	•		40-Pin TH, 44-Pin SMT
M-986-2R2P	Transceiver		•	•		•		40-Pin TH, 44-Pin SMT
M-993	Generator	•					•	14-Pin DIP TH

Block Diagram

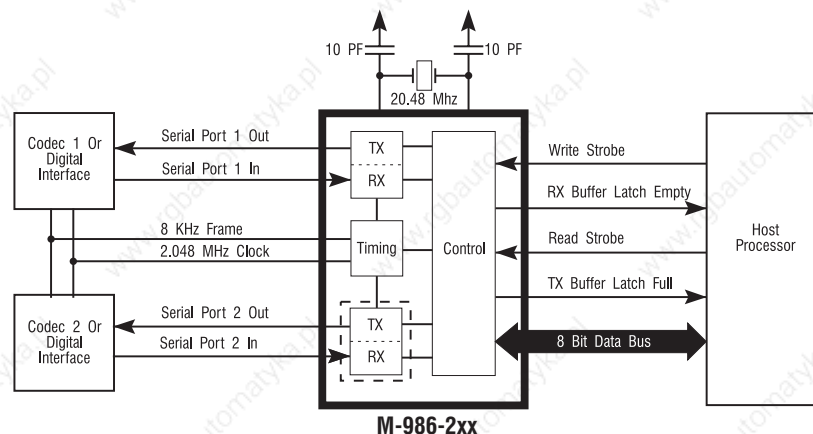

High Voltage Products - Analog Switches and Display Drivers



The high voltage process technology used on these devices is Clare's reliable BCDMOS on SOI (Silicon On Insulator). This process offers unique performance features such as multiple 300V open drain FET devices and 200V bi-directional analog switch cells with 1 Amp peak current capability.

NEW - CPC7220/CPC7221 High Voltage 8 Channel Analog Switch

The CPC7220 and CPC7221 are low charge injection 8-channel high-voltage analog switch integrated circuits (ICs). These devices are capable of switching large load voltages and have a flexible load voltage range, e.g. V_{PP}/V_{NN} : +40V/-160V or +100V/-100V. Switch manipulation is managed by an 8-bit serial to parallel shift register whose outputs are buffered and stored by an 8-bit transparent latch. Level shifters buffer the latch outputs and operate the high voltage switches.

Features

- DC to 10MHz analog signal frequency
- 200 V peak to peak output switches
- Low quiescent power dissipation (< 1 μ A typical)
- Output on-resistance typically 20 Ω
- TTL I/O's for 3.3 V interface
- 28-Pin SOIC Package

Applications

- Ultrasound imaging
- Printers
- Industrial controls and measurement



Block Diagram

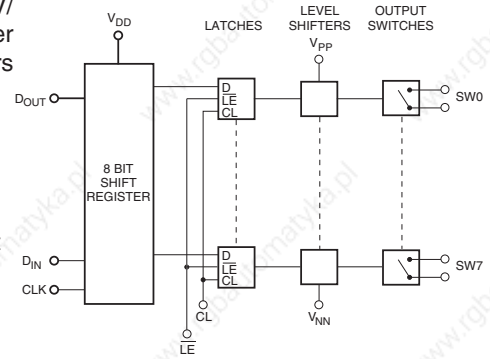

NEW - CPC6530 32-Channel Serial To Parallel Converter With Open Drain Outputs

The CPC6530 is a low-voltage serial input to high-voltage parallel output converter with open drain outputs. This device consists of a 32-bit shift register, 32 latches, and control logic to perform the polarity select and blanking of the outputs. The open drain n-channel MOSFETS have a 300V breakdown voltage rating and are capable of sinking 100mA of current.

Features

- 300V open drain MOSFETs
- 100mA minimum current sink
- 8 MHz shift register
- Polarity and Blanking inputs
- CMOS compatible inputs
- 44-lead surface mount package

Applications

- EL Display Driver
- Inkjet and electrostatic print heads
- Plasma, vacuum fluorescent and large matrix LCDs



Block Diagram

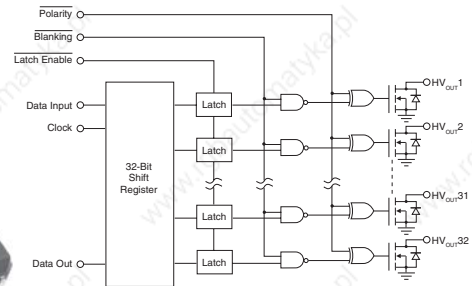

NEW - CPC6826 High Voltage EL Lamp Driver

The CPC6826 is an electroluminescent (EL) lamp driver designed for applications operating from an input supply voltage range of 1.8 V to 3.5 V. The architecture features an integrated boost switching supply with an H-bridge driver circuit to illuminate the EL lamp. Three passive components, an inductor, a capacitor and a diode are required to complete the boost switcher circuit. The internal high voltage H-bridge provides a nominal ± 75 V output between pins V_A and V_B .

Features

- 1.8 V to 3.5 V supply voltage
- DC to AC conversion
- Adjustable output frequency
- Adjustable switch frequency
- Output voltage regulation
- 150V_{PP} H-Bridge drive output
- Enable/disable function
- MSOP-8 Package

Applications

- Mobile cellular phones
- Keypad illumination
- Instrument panels



Block Diagram

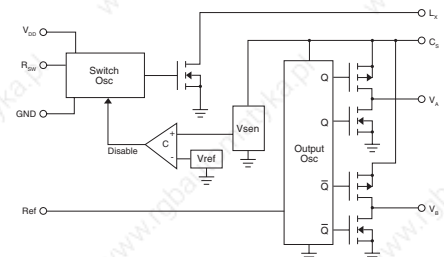

Optically Isolated Gate Driver Circuits

The CPC1580 and CPC1590 are high speed Optically Isolated Gate Driver ICs. On-chip circuitry charges an external capacitor from the AC load voltage which eliminates the need for an external IC power supply. The Driver IC is ideal for low duty cycle switching applications.

Features

- Low drive power requirements (TTL/CMOS Compatible)
- Fast switching T_{ON}/T_{OFF} 20/200 μ sec
- Load Voltages up to 200V
- No external IC power supply



Applications

- Instrumentation
 - Multiplexers
 - Electronic switching
 - I/O Subsystems
 - Meters (Watt-Hour, Water, Gas)
- Medical Equipment (patient/equipment isolation)
- Security
- Aerospace
- Industrial controls

Operational temperature range of -40° to 85°C

Part Number	Input Control Current	Gate Voltage @ $I_F = 5\text{mA}$ (V_G)	Load Voltage (V_D)	Regulated Voltage Capacitor (V_{CAP})	Nominal Switching Speeds T_{ON}/T_{OFF} (ms)	Isolation Voltage (V_{rms})	Package ¹ Type	Features
CPC1580	5	7.3 to 12	50	49.9	0.04 / 0.7	3750	8-Pin SMT	NEW
CPC1590	5	7.2 to 9.1	200	20	0.02 / 0.2	3750	8-Pin SMT	NEW

¹ For Package Type, SMT indicates Surface Mount Technology while TH indicates Through-hole.

Block Diagrams

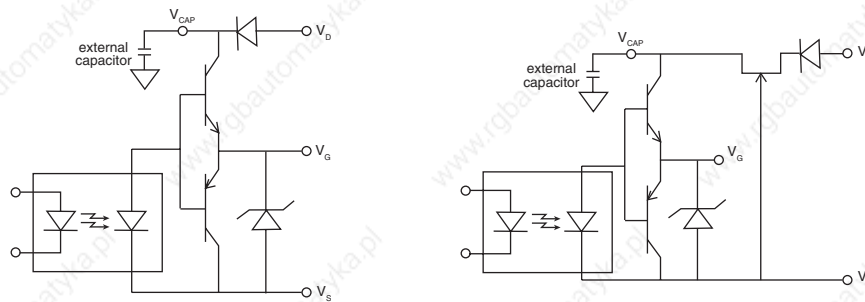

Optically Isolated Dual MOSFET Gate Driver

The FDA215 is a Dual Optically Isolated Photodiode Array. The light activated array produces an open circuit voltage of 8 Volts. This device is suited for use in discrete solid state relay designs.

Features

- Isolated 5V photovoltaic output
- May be configured for AC and DC switching
- Floating outputs for parallel or series configuration

Applications

- MOSFET Driver
- Programmable control
- Process control
- Instrumentation

Operational temperature range of -40° to 85°C

Part Number	Input Control Current I_F (mA)	Open Circuit Voltage (V_{OC})	Nominal Short Circuit Current I_{SC} (μ A)	Switching Speeds T_{ON}/T_{OFF} (ms)	Isolation Voltage (V_{rms})	Package ¹ Type
FDA215	5	5	2.5	5 / 5	3750	8-Pin SMT, TH

¹ For Package Type, SMT indicates Surface Mount Technology while TH indicates Through-hole.

Block Diagram

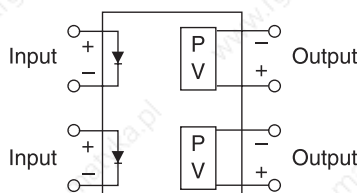

Solar Cell Products

The Clare Solar Cell is a revolutionary new product offering that addresses the diverse needs and applications of the growing low power solar energy market. This technology development is based on Clare's strength in photovoltaic silicon processing and IC packaging. The Solar Cell product family offers several open circuit voltage levels (4, 8 or 16 Volts) when activated by natural or artificial light. These voltage levels correlate to common circuit board power supply voltages making the solar cell ideal for battery charging applications and trickle charge power sources. Standard JEDEC SOIC package styles make

these Solar Cell products ideal for prototype and high volume production usage.

Clare's flexible Solar Cell architecture facilitates product family growth by means of its scalable technology thus paving the way for future solar cell offerings with different voltage and current ratings. Additionally, since there is excellent isolation between the various circuit elements on the Solar Cell's photovoltaic die, it is possible to add options such as power management or logic control circuitry with minimal incremental cost to the product.

Features

- Select from multiple voltage and current outputs
- 4 V - 16 V output
- 12 μ A - 100 μ A current output
- Provides true wireless power
- Triggers with natural sunlight or artificial light
- Semiconductor miniature size and reliability

Applications

- Portable Electronics
- Solar Battery Chargers
- Battery Operated Equipment
- Consumer Electronics
- Off Grid Installation
- Wireless Sensors and Detection
- Self Powered Sunlight/ Light Detection
- Self Powered Products
- Remote Installation

Product Part Number	Open Circuit Voltage (V)	Short Circuit Current (μ A)	SOIC Package
CPC1822	4	50	8-Pin
CPC1824	4	100	16-Pin
CPC1831	8	25	8-Pin
CPC1832	8	50	16-Pin
CPC1840	16	12	8-Pin
CPC1841	16	25	16-Pin

Block Diagram

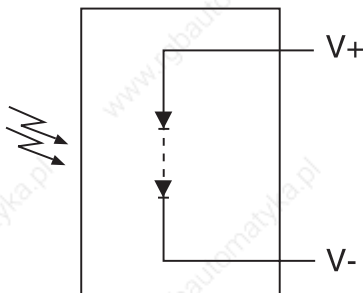

Application Notes

The following application notes can be downloaded from our web site at www.clare.com

General

- AN-130 Handling MOS Devices

Solid-State Relays

- AN-108 Current Limited Solid State Relays
- AN-145 Advantages of Solid State Relays Over Electromechanical Relays (English, Espanol, Deutsch, Francais)

Opto-Isolators

- AN-107 LOCxx Series - Isolated Amplifier Design Principals
- AN-109 LOC110 - Variable Speed Motor Controller Design
- AN-111 Isolated 0-10 V to 4-20 mA Converter Application
- AN-118 Detecting Line Polarity Reversal

Multifunction Products

- AN-112 Ground-Start Supervision Circuit Using Clare's IAA110
- AN-114 ITC117P Integrated Telecom Circuits

Line Interface Products

LCAS

- AN-100 Design Surge and Power Fault Protection for Subscriber Line Interfaces
- AN-144 Impulse Noise Benefits of Line Card Access Switches
- AN-154 LCAS Longitudinal Balance Calculator Excel Spreadsheet for Line Card Applications

LITELINK Silicon DAA

- AN-102 Loop Current Detection for LITELINK
- AN-140 Understanding LITELINK
- AN-146 Guidelines for Effective LITELINK Designs
- AN-155 Understanding LITELINK Display Feature Signal Routing and Applications
- AN-157 Increased LITELINK Transmit Power
- AN-158 LITELINKIII Application Circuit Calculations

Tone Signaling Products

- AN-125 M-986 - Configuring the M-986 MF Trunk Signaling
- AN-128 M-980 - Algorithm for Call Progress Signal Detection
- AN-129 M-991 - Call Progress Tone Generator
- AN-130 Call Progress Tone Standards
- AN-132 M-980 - Clare Components in Private Pay Stations
- AN-138 M-980 - Call Progress Tone Detector Applications
- AN-142 M-949 - Loop Current Sensing and Ring Chatter

ISOPLUS Family

ISOPLUS220™

ISOPLUS247™

ISOPLUS264™

ISOPLUS i4-PAC™

ISOPLUS-DIL™

Isolated Discrete Packages

ISOPLUS247™ is the DCB isolated version of the PLUS247™-package (TO-247 without a mounting hole). The design of this new package patented is revolutionary: the silicon chip is soft soldered onto a Direct Copper Bond (DCB) substrate instead of the usual copper lead frame. The DCB ceramic, the same substrate material used in the high power modules, not only provides high isolation capability (2500 V_{RMS}) but also unbeatable low thermal resistance compared to conventional, external mounted isolation materials.

Advantages:

- Isolation capability from leads to backside 2500 V_{RMS} – no external isolation foil needed
- Thermal resistance from Junction to Case only slightly higher as for non-isolated version
- Increased power- and temperature cycling capability
- DCB can be patterned like printed circuit boards – allowing special functions to be realized

Parts in the **ISOPLUS247™** housing can be identified by the letter “R” in the IXYS part number. Potentially all devices now encapsulated in TO-247, TO-264 and PLUS247™ housings can be molded in the **ISOPLUS247™**. There are already more than 100 different **ISOPLUS247™** types available.

Another interesting feature is the capability to pattern the DCB substrate like a printed circuit board. Now additional special functions can be realized, e.g. the **series connection of single diode** chips within one package.

Package cross section

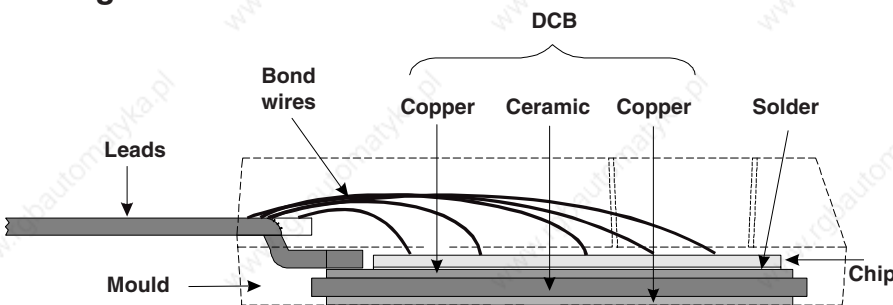

While the junction-to-case thermal resistance is higher than an equivalent, non-isolated device, what really matters is the total thermal resistance from junction-to-heat sink ($R_{th(j-h)}$). Comparing a device in **ISOPLUS247™** to its companion in the non-isolated package with an external isolation foil, one can see that the overall R_{th} is now lower for the part in the already isolated package (see example).

Due to the matched thermal expansion coefficients of silicon and DCB ceramic, mechanical stress to the die and solder caused by power- and temperature cycling is reduced so that reliability is improved. Mounting is done with clips, which not only saves time but also guarantees constant pressure force over the whole lifetime of the assembly.

ISOPLUS220™, **ISOPLUS247™** and **ISOPLUS264™** are the DCB substitutes for the corresponding standard packages.

A larger version of this packaging technology is named **ISOPLUS i4-PAC™**. It has up to five terminal pins, making it possible to build up full diode bridges, phase-leg transistor configurations, buck and boost converters and much more within one isolated discrete package.

ISOPLUS-DIL™ is the latest member of IXYS **ISOPLUS** family. 37,5mm long and 25mm wide, plane power pins for 300A RMS on one side and 12 control pins on the opposite side enables IXYS to provide the user with high current sixpack configuration in one package.

Package version with DAB - the latest development of IXYS - will be available soon. DAB differs from DCB by using Aluminium instead of Copper foils to achieve further improved cycling performance.

ISOPLUS-DIL™ features the highest power density and reliability and is therefore ideally suited for automotive designs.

Example: ISOPLUS247™ compared to conventional isolated device

Type	Package	Isolation	$R_{th(j-c)}$ K/W	$R_{th(c-k)}$ K/W	Total K/W	Factor
IXFR 180N10	ISOPLUS247™	internal DCB	0.30	0.15	0.45	1.0
IXFX 180N10	PLUS247™	external foil	0.22	1.02	1.24	2.8

ISOPLUS220™

Product	Type	V _{DSS}	I _{D(cont)}	R _{DS(on) max}
MOSFETs				
Trench Gate	IXUC 100N055	55 V	100 A	6.1 mΩ
	IXTC 240N055T	55 V	140 A	3.3 mΩ
	IXTC 280N055T	55 V	164 A	2.8 mΩ
	IXUC 200N055	55 V	200 A	4.0 mΩ
	IXTC 220N075T	75 V	125 A	4.0 mΩ
	IXTC 250N075T	75 V	150 A	3.4 mΩ
	IXUC 160N075	75 V	160 A	5.1 mΩ
	IXTC 200N085T	85 V	110 A	5.0 mΩ
	IXTC 230N085T	85 V	136 A	3.3 mΩ
	IXUC 60N10	100 V	60 A	12.8 mΩ
	IXTC 180N10T	100 V	100 A	6.1 mΩ
	IXTC 200N10T	100 V	118 A	5.4 mΩ
	IXUC 120N10	100 V	120 A	7.3 mΩ

Polar	IXFC 110N10P	100 V	60 A	15 mΩ
	IXFC 96N15P	150 V	96 A	24 mΩ
	IXFC 74N20P	200 V	74 A	34 mΩ
	IXFC 52N30P	300 V	52 A	66 mΩ
	IXFC 16N50P	500 V	10 A	400 mΩ
	IXFC 26N50P	500 V	15 A	230 mΩ
	IXFC 36N50P	500 V	19 A	170 mΩ
	IXFC 14N60P	600 V	8 A	600 mΩ
	IXFC 22N60P	600 V	12 A	360 mΩ
	IXFC 30N60P	600 V	24 A	270 mΩ
	IXFC 10N80P	800 V	5 A	1100 mΩ
	IXFC 12N80P	800 V	7 A	850 mΩ
	IXFC 14N80P	800 V	8 A	700 mΩ
	IXFC 16N80P	800 V	9 A	600 mΩ
	IXFC 20N80P	800 V	13 A	500 mΩ

CoolMOS	IXKC 20N60C	600 V	14 A	190 mΩ
	IXKC 40N60C	600 V	28 A	96 mΩ
	IXKC 13N80C	800 V	13 A	290 mΩ
	IXKC 25N80C	800 V	25 A	150 mΩ

Product	Type	V _{CES}	I _C	V _{CE(sat)max}	t _{fi}
IGBTs	IXGC 16N60B2	600 V	28 A	2.3 V	80 ns
	IXGC 16N60C2	600 V	20 A	3.0 V	35 ns
	IXGC 16N60C2D1	600 V	20 A	3.0 V	35 ns

Product	Type	V _{RRM}	I _F	V _F	t _{fi}
Dual Ultrafast Diodes					
Series connected					
	DSEE 6-06CC	600 V	10 A	1.35 V	20 ns
	DSEE 8-06CC	600 V	10 A	1.30 V	30 ns
	DSEE 15-06CC	600 V	15 A	1.25 V	30 ns
	DSEE 29-06CC	600 V	30 A	1.01 V	30 ns
	DSEE 8-08CC	800 V	10 A	1.12 V	30 ns
	DSEE 15-12CC	1200 V	15 A	1.50 V	35 ns
	DSEE 29-12CC	1200 V	30 A	1.75 V	30 ns

Common anode connected					
	DSEA 16-06AC	600 V	2x10 A	1.42 V	35 ns
	DSEA 16-06BC	600 V	2x10 A	1.66 V	30 ns
	DSEA 29-06AC	600 V	2x15 A	1.34 V	35 ns
	DSEA 59-06BC	600 V	2x30 A	1.56 V	30 ns

If your application requires electrically isolated TO-220 device, then it needs ISOPLUS220™ parts. We have replaced the normal copper lead frame with our proprietary lead frame to give it -

- Superior heat transfer junction to heatsink
- 2500 V isolation voltage
- Higher current and power control

Available products include

- MOSFETs
- IGBTs
- FREDs
- SCRs
- Rectifiers
- Schottky diodes

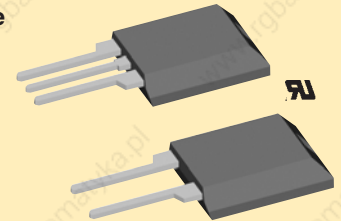

Product	Type	V _{RRM}	I _F	V _F	t _{fi}
Dual Ultrafast Diodes					
Common cathode connected					
					<i>T_{VJ} = 150°C</i>
	DSEC 16-06AC	600 V	2x10 A	1.42 V	35 ns
	DSEC 16-06BC	600 V	2x10 A	1.66 V	30 ns
	DSEC 29-06AC	600 V	2x15 A	1.34 V	35 ns
	DSEC 59-06BC	600 V	2x30 A	1.56 V	30 ns

Schottky Diode					
					<i>T_{VJ} = 125°C</i>
	DSS 20-01AC	100 V	20 A	0.76 V	

GaAs Schottky Diode					
Series connected					
					<i>T_{VJ} = 125°C</i>
	DGSS 6-06CC	600 V	6 A	1.20 V	
	DGSS 10-06CC	600 V	10 A	1.20 V	
	DGSS 20-06CC	600 V	20 A	1.20 V	

Rectifier Diode					
					<i>T_{VJ} = 150°C</i>
	DSI 30-12AC	1200 V	30 A	1.25 V	

Series connected					
	DSP 8-12AC	2x1200 V	2x10 A	1.21 V	

Product	Type	V _{RRM}	I _T	V _T
Thyristor				
				<i>T_{VJ} = 125°C</i>
	CS 19-12ho1C	1200 V	30 A	1.74 V
	CS 29-12io1C	1200 V	45 A	1.56 V

See alphanumeric index for the page number of the particular product.

ISOPLUS247™, ISO264 and ISOPLUS264™

Isolating TO-247 power devices has never been easier than using our new ISOPLUS247™ products. They're internally isolated with our proprietary "integrated leadframe" using our DCB ceramic substrate as part of the package!

The result -

- **Excellent thermal transfer** ($R_{th(j-c)}$)
- **High Isolation Voltage** ($V_{ISOL} > 2500$ V)
- **Increased Temperature & Power Cycling** capability
- **Reduced EMI/RFI** emissions due to lower stray capacitance (junction to heatsink).

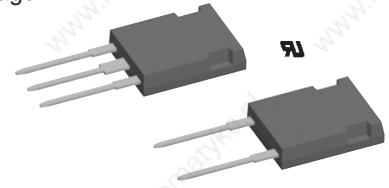

Type	V_{DSS}	$I_{D(cont)}$	$R_{DS(on) max}$
------	-----------	---------------	------------------

MOSFETs in ISOPLUS247™

IXTR 200N10P	100 V	120 A	0.008 Ω
IXFR 200N10P	100 V	120 A	0.0075 Ω
IXFR 180N15P	150 V	180 A	0.013 Ω
IXFR 140N20P	200 V	90 A	0.022 Ω
IXFR 102N30P	300 V	60 A	0.036 Ω
IXFR 140N30P	300 V	82 A	0.024 Ω
IXFR 36N50P	500 V	19 A	0.17 Ω
IXFR 44N50P	500 V	24 A	0.15 Ω
IXFR 64N50P	500 V	35 A	0.1 Ω
IXFR 80N50P	500 V	45 A	0.07 Ω
IXFR 40N50Q2	500 V	29 A	0.14 Ω
IXFR 66N50Q2	500 V	50 A	0.074 Ω
IXFR 30N60P	600 V	15 A	0.27 Ω
IXFR 36N60P	600 V	20 A	0.2 Ω
IXFR 48N60P	600 V	32 A	0.15 Ω
IXFR 64N60P	600 V	36 A	0.1 Ω
IXKR 40N60C	600 V	38 A	0.07 Ω
IXFR 20N80P	800 V	10 A	0.5 Ω
IXFR 24N80P	800 V	14 A	0.4 Ω
IXFR 32N80P	800 V	20 A	0.27 Ω
IXFR 44N80P	800 V	26 A	0.19 Ω
IXFR 38N80Q2	800 V	28 A	0.3 Ω
IXKR 25N80C	800 V	25 A	0.15 Ω
IXFR 24N90Q	900 V	24 A	0.4 Ω
IXFR 4N100Q	1000 V	3.5 A	3 Ω
IXFR 14N100Q2	1000 V	9.1 A	1 Ω
IXFR 21N100Q	1000 V	19 A	0.5 Ω
IXFR 24N100	1000 V	28 A	0.39 Ω

MOSFETs in ISOPLUS264™

IXFL 100N50P	500 V	70 A	0.05 Ω
IXFL 80N50Q2	500 V	80 A	0.066 Ω
IXFL 82N60P	600 V	54 A	0.08 Ω
IXKL 60N80P	800 V	42 A	0.14 Ω
IXFL 38N100Q2	800 V	22 A	0.28 Ω
IXKL 34N100	800 V	34 A	0.28 Ω

MOSFETs in ISO264™

IXKG 25N80C	800 V	25 A	0.15 Ω
-------------	-------	------	---------------

Type	V_{CES}	I_C	$V_{CE(sat) max}$	t_{fi}
------	-----------	-------	-------------------	----------

IGBTs in ISOPLUS247™

IXGR 40N60B2	600 V	60 A	1.9 V	82 ns
IXGR 40N60C2	600 V	56 A	2.7 V	32 ns
IXGR 50N60B2	600 V	68 A	2.2 V	65 ns
IXGR 50N60C2	600 V	75 A	2.7 V	48 ns
IXGR 60N60B2	600 V	75 A	2.0 V	100 ns
IXGR 60N60C2	600 V	75 A	2.7 V	35 ns
IXGR 120N60C2	600 V	75 A	2.7 V	45 ns
IXGR 120N60B	600 V	156 A	2.1 V	160 ns
IXGR 35N120B	1200 V	70 A	3.3 V	160 ns

IGBTs in ISOPLUS264™

IXEL 40N400	4000 V	62 A	4.4 V	450 ns
-------------	--------	------	-------	--------

Type	V_{CES}	I_C	$V_{CE(sat) max}$	t_{fi}
------	-----------	-------	-------------------	----------

IGBT + FRED

IXGR 40N60C2D1	600 V	56 A	2.7 V	32 ns
IXGR 50N60C2D1	600 V	75 A	2.7 V	48 ns
IXGR 60N60C2D1	600 V	75 A	2.7 V	35 ns
IXGR 32N90B2D1	900 V	47 A	2.9 V	165 ns
IXGR 50N90B2D1	900 V	40 A	2.9 V	200 ns
IXSR 35N120BD1	1200 V	52 A	3.6 V	180 ns
IXGR 32N170H1	1700 V	38 A	3.5 V	250 ns
IXGR 32N170AH1	1700 V	26 A	5.2 V	50 ns

Type	V_{RRM}	I_F	V_F	t_{rr}
------	-----------	-------	-------	----------

UltraFast Rectifiers

$T_{vj} = 150^\circ C$

DSEK 60-02AR	200 V	2x30 A	0.85 V	35 ns
DSEC 60-03AR	300 V	2x30 A	0.91 V	30 ns
DSEP 9-06CR	600 V	9 A	2.90 V	15 ns
DSS 17-06CR	600 V	15 A	2.71 V	15 ns
DSEP 30-06BR	600 V	30 A	1.56 V	30 ns
DSEP 30-06CR	600 V	30 A	2.15 V	30 ns
DSEI 30-10AR	1000 V	30 A	1.88 V	35 ns
DSEP 15-12CR	1200 V	15 A	2.67 V	20 ns
DSEP 30-12CR	1200 V	30 A	3.10 V	20 ns
DSEP 30-12AR	1200 V	30 A	1.79 V	40 ns
DSEP 60-12AR	1200 V	60 A	1.74 V	40 ns

Schottky

$T_{vj} = 125^\circ C$

DSSS 35-008AR	80 V	35 A	0.68 V
DSSS 30-01AR	100 V	30 A	0.63 V
DSSK 80-006BR	60 V	2x40 A	0.51 V
DSSK 70-008AR	80 V	2x35 A	0.64 V
DSSK 60-015AR	150 V	2x30 A	0.69 V
DSSK 60-02AR	200 V	2x30 A	0.70 V

Rectifiers

$T_{vj} = 150^\circ C$

DSP 25-16AR	1600 V	25 A	1.18 V
DSI 45-16AR	1600 V	45 A	1.30 V
DSP 45-16AR	1600 V	45 A	1.30 V
DSIK 45-16AR	1600 V	2x45 A	1.30 V

Type	V_{RRM}	I_T	V_T
------	-----------	-------	-------

Thyristor

$T_{vj} = 125^\circ C$

CS 45-16io1R	1600 V	80 A	1.73 V
--------------	--------	------	--------

See alphanumeric index for the page number of the particular part

ISOPLUS i4-PAC™

3, 4 and 5 leaved packages for various circuit topologies

DCB base plate

- 2500 V electrical isolation
- low thermal resistance
- increased power & temperature cycling
- saves space
- replaces multiple discretes
- reduces parasitic inductance and capacitance
- reduces EMI

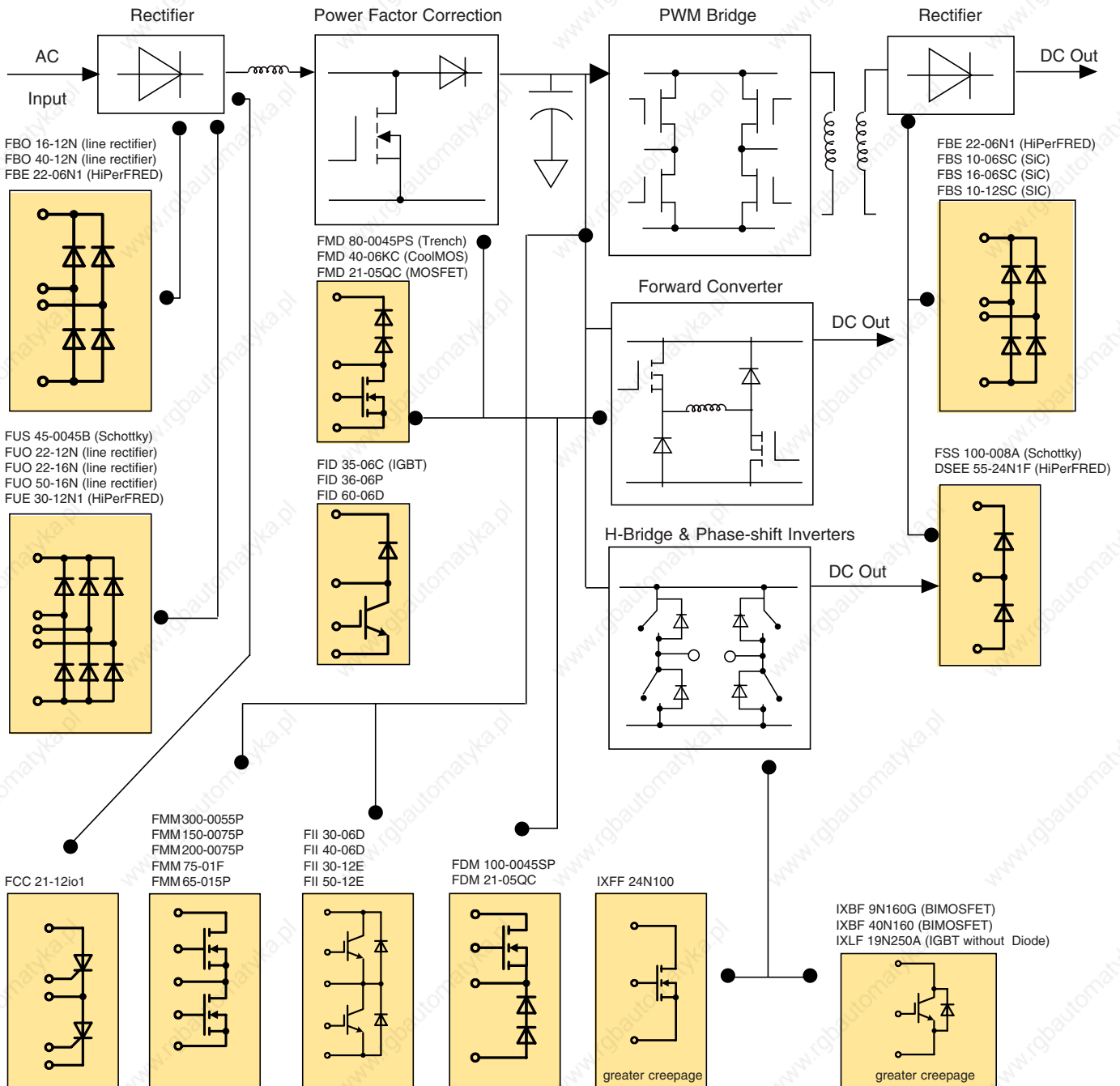
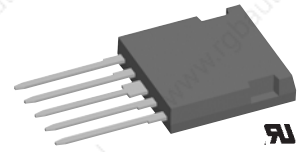

See application note "Combining the features of modules and discretes in a new Power Semiconductor packages" for general description of the packaging technologies.

See alphanumeric index for the page number of the particular product.

ISOPLUS i4-PAC™

Products with MOSFET

Type	Configuration	Technology/ Circuit diagram	V _{DSS}	I _{D25} @ 25°C	I _{D90} @ 90°C	R _{DS(on) typ.} T _c = 25°C	Fig. No.	Package style Outline drawings on page 188 - 224
► New			V	A	A	mΩ		
FMM 300-0055P	<i>phaseleg</i>	Trench MOSFET	B	55	300	220	2.7	X024a
FMM 150-0075P	<i>phaseleg</i>	Trench MOSFET	B	75	150	120	4.7	
FMM 75-01F	<i>phaseleg</i>	HiPerFET	B	100	75	50	20	
FMM 65-015P	<i>phaseleg</i>	Trench MOSFET	B	150	65	50	13	
FMD 80-0045PS	<i>boost</i>	Trench MOSFET & Schottky	D	55	150	110	3.8	
FMD 21-05QC	<i>boost</i>	HiPerFET & HiPerDynFRED	E	500	21	15	180	
FMD 40-06KC	<i>boost</i>	CoolMOS & HiPerDynFRED	E	600	38	25	60	
FDM 100-0045SP	<i>buck</i>	Trench MOSFET & Schottky	F	45	100	80	5.7	
FDM 21-05QC	<i>buck</i>	HiPerFET & HiPerDynFRED	G	500	21	15	180	
IXFF 24N100	<i>single</i>	HiPerFET	A	1000	22	15	320	
IXKF 40N60SCD1	<i>single</i>	CoolMOS & serial Schottky & HiPerFRED as free wheeling diode	H	600	38	25	60	

COOLMOS™ Power Semiconductors CoolMOS™ is a trademark of Infineon Technologies

X024a
ISOPLUS i4-PAC™
Weight = 6 g

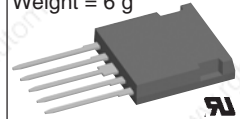

Products with IGBT

Type	Configuration	Technology / Circuit diagram	V _{CES}	I _{C25} @ 25°C	I _{C90} @ 90°C	V _{CE(sat) typ.} T _c = 25°C	Fig. No.	
► New			V	A	A	V		
FII 30-06D	<i>phaseleg</i>	NPT IGBT	K	600	30	18	1.9	X024a
FII 40-06D	<i>phaseleg</i>	NPT IGBT	K	600	40	25	1.8	
FII 30-12E	<i>phaseleg</i>	NPT ³ IGBT	K	1200	50	32	2.4	
FII 50-12E	<i>phaseleg</i>	NPT ³ IGBT	K	1200	50	32	2.0	
FID 35-06C	<i>boost</i>	NPT IGBT & HiPerDynFRED	L	600	38	24	1.9	
FID 36-06D	<i>boost</i>	NPT IGBT & HiPerFRED	M	600	38	24	1.9	
FID 60-06D	<i>boost</i>	NPT IGBT & HiPerFRED	M	600	65	40	1.6	
IXBF 9N160G	<i>single</i>	BiMOSFET	J	1600	7	4	4.9	
IXBF 40N160	<i>single</i>	BiMOSFET	J	1600	28	16	6.2	
IXLF 19N250A	<i>single</i>	High voltage IGBT	I	2500	32	19	3.2	

X024c
ISOPLUS i4-PAC™
Weight = 6 g

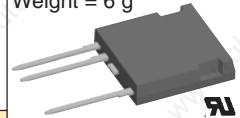

AC Switch

Type	Configuration	Voltage	Current @ T _c = 90°C	Circuit diagram	Fig. No.
► New		V	A		
FMK 75-01F FIO 50-12BD	MOSFET Common Source 1-phase Bridge and IGBT	100 1200	50 32	C N	X024a

- **Applications**
- Lighting Control 1 device replaces a Triac
 - White Goods 2 devices for Motor Control
 - Matrix Inverter 9 devices for 3 Phase Motor Control without DC Link Capacitor

Circuit diagram

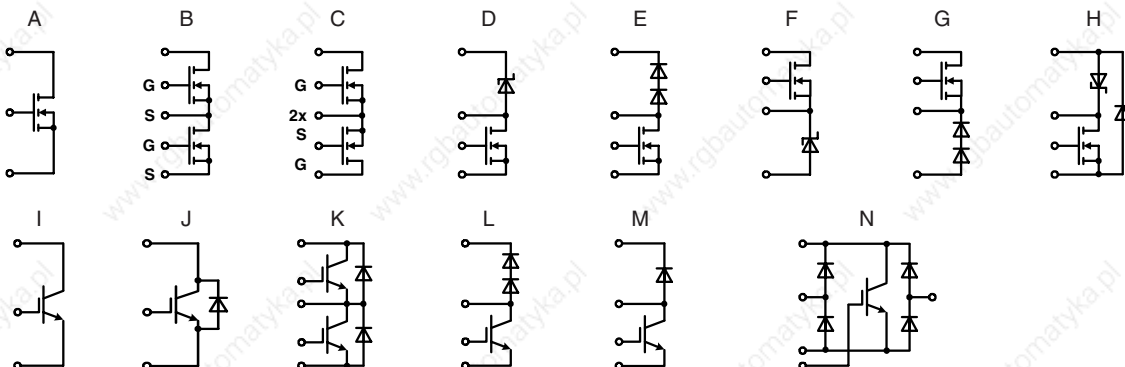

ISOPLUS i4-PAC™

Bipolar Products

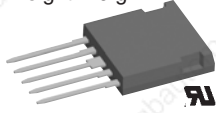
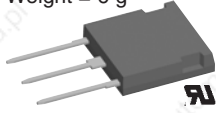
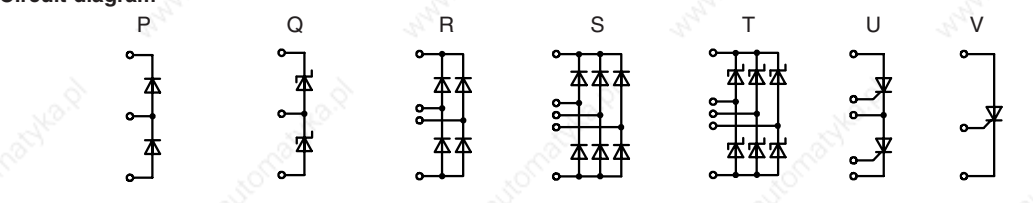
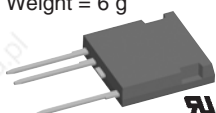
Type	Configuration	Diode type	Voltage	$I_{D(AV)M}$ @ $T_c = 90^\circ C$	Circuit diagram	Fig. No.	Package style Outline drawings on page 188 - 224
► New			V	A			
FUS 45-0045B	3-phase bridge	Schottky	45	45	T	X024a	X024a ISOPLUS i4-PAC™ Weight = 6 g 
FSS 100-008A	phase leg	Schottky	80	90	Q	X024b	
FBS 10-06SC	1-phase bridge	Si-Carbide	600	6.6	R	X024a	
FBS 16-06SC	1-phase bridge	Si-Carbide	600	11	R		
► FBS 10-12SC	1-phase bridge	Si-Carbide	1200	under development	R		
FBE 22-06N1	1-phase bridge	HiperFRED	600	20	R		
FUE 30-12N1	3-phase bridge	HiperFRED	1200	30	S		
FBO 16-12N	1-phase bridge	Rectifier	1200	22	R		
FBO 40-12N	1-phase bridge	Rectifier	1200	40	R		
FUO 22-12N	3-phase bridge	Rectifier	1200	27	S		
FUO 22-16N	3-phase bridge	Rectifier	1600	27	S		
FUO 50-16N	3-phase bridge	Rectifier	1600	50	S		
FCC 21-12io	phaseleg	Thyristor	1200	21	U		
CS 20-22moF1	single part, high voltage	Thyristor	2200	18	V	X024c	X024b ISOPLUS i4-PAC™ Weight = 6 g 
DSEE 55-24N1F	phase leg	HiperFRED	2400*	55	P	X024b	
► DHH 55-36N1F	phase leg	SonicFRD	3600*	50	P		
* series connected							
Circuit diagram 							
							X024c ISOPLUS i4-PAC™ Weight = 6 g 

ISOPLUS-DIL™

High Current low $R_{DS(on)}$ Trench MOSFET Six-Pack

New DCB based surface mount package for automotive applications

In the automotive industry the usage of electronics is growing each year, especially with MOSFET technology. Steering aids, valve control, active suspension and many other functions in a car are driven by MOSFET's. The trends in these applications are the usage of Trench MOSFET and miniaturization of the electronic components, which results in low inductance designs with low EMC disturbance, easy manufacturability and the most important one, reliability. IXYS has introduced the new GWM product series exactly for these applications fulfilling these market demands.

The standard GWM ISOPLUS-DIL (Dual-In-Line) package includes a Trench MOSFET Six-pack, also customized configurations can be integrated.

The ISOPLUS-DIL package is a new member of the IXYS ISOPLUS family. The IXYS ISOPLUS family is well known for its advantages; the expansion coefficient of the DCB is close to that of silicon which results in high temperature cycle reliability, the heat transfer through the ceramic is optimal, if the GWM is compared with standard solutions the current loops are reduced and also the parasitic capacity is reduced. Both results in better EMI behavior of the application. The advantages of the Direct Copper Bonded substrate results in a very reliable, high power density component. The GWM, targeted for the automotive segment, is tested according to the AEC-Q101.

The GWM ISOPLUS-DIL six-pack is a very compact and reliable solution for automotive applications, which contains the latest technology trench MOSFET's. With the electrical and mechanical properties of the GWM ISOPLUS-DIL, design-in and usability is improved compared to solutions currently used.

ISOPLUS-DIL™

Features

- Low $R_{DS(on)}$
- Optimized intrinsic reverse diode
- High level of integration
- Multi chip packaging
- High power density
- High current power terminals (300 A, RMS)
- Auxiliary terminals for MOSFET control
- Terminals for soldering (wave or re-flow) or welding connections
- Isolated DCB ceramic base plate with optimized heat transfer
- 1000 V electrical isolation
- Logic level version feasible

Applications

- Automobile electric power steering
- Active suspension
- Water pump
- Automobile starter generator
- Propulsion drives
- Fork lift drives
- Battery operated equipment

Benefits

- Highest reliability
- Easy assembly
- Optimized EMI behavior
- Extremely low power loss

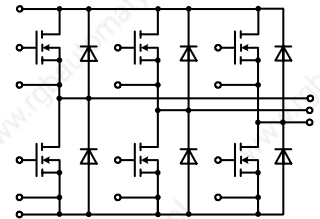

6-pack Trench MOSFET

Type	Trench	V_{DS} Max. V	$I_{D(cont)}$ $T_c = 25^\circ C$ A	I_{D90} $T_c = 90^\circ C$ A	$R_{DS(on) typ}$ $T_c = 25^\circ C$ m Ω	$Q_{G(on)}$ typ nC	t_{rr} typ. ns	Fig. No.	xxx = Order Code:
► New									
GWM 220-004P3-xxx	standard	40	190	145	2.0	94	70	X026	
GWM 160-0055P3-xxx	standard	55	160	120	2.3	86	100		SL Straight Leads
GWM 120-0075P3-xxx	standard	75	125	95	3.7	91	90	-SL	BL Bent Leads
► GWM 100-0085X1-xxx	standard	85		under development					SMD Surface Mount Device
GWM 70-01P2-xxx	standard	100	70	50	11	110	80	-SMD	
► GWM 95-01X1-xxx	standard	100		under development					

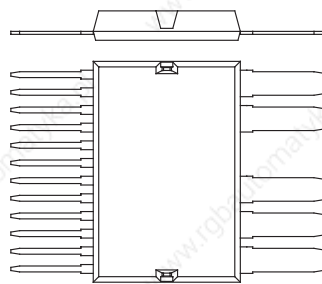

X026a ISOPLUS-DIL™
Weight = 25 g xxx-SL

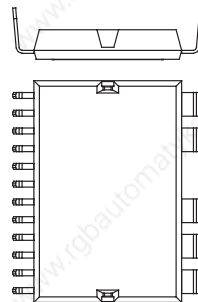

X026b ISOPLUS-DIL™
Weight = 25 g xxx-BL

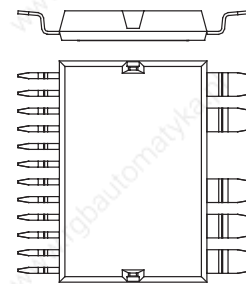

X026c ISOPLUS-DIL™
Weight = 25 g xxx-SMD

Package style

Outline drawings on page 188 - 224

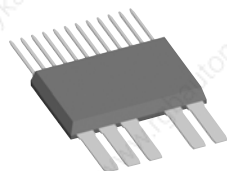

Order Code: SL
(Straight Leads)



Order Code: BL
(Bent Leads)



Order Code: SMD
(Surface Mount Device)

Insulated Gate Bipolar Transistors (IGBT)

An IGBT derives its advantages from a MOSFET and BJT. It operates as a MOSFET with an injecting region on its Drain side to provide for conductivity modulation of the Drain drift region so that on-state losses are reduced, especially when compared to an equally rated high voltage MOSFET. Thus, IGBTs have lower on-state voltage drops with high blocking voltage capabilities, in addition to fast switching speeds, while still featuring smaller chip sizes as compared to equally rated MOSFETs.

IXYS has been making continuous innovation in developing and introducing newer and better IGBTs. As a result, many new IGBT types offered are optimized for critical power conversion applications:

A2-Class features 600V devices with switching frequency ranges of DC to 10 kHz.

B2-Class features 600 V devices with switching frequency ranges of 1 kHz to 100 kHz.

C2-Class features 600 V devices with switching frequency ranges of 25 kHz to 200 kHz.

These new IGBTs use IXYS' Next Generation IGBT Technology, tailored to provide significant improvements in efficiency for off-line power conversion applications. The A2 and B2-Class IGBTs have up to 25% lower saturation voltage and lower turn-off energy, while the C2-Class IGBTs have up to 50% lower turn-off energy and reduced saturation voltage versus prior generation of IGBTs. These performance improvements are further enhanced by a 25% reduction in thermal resistance, additionally providing significant increases in power handling and reliability. A myriad of applications stand to benefit from the unique advantages of power handling and efficiency offered in the range of slow to high frequency IGBTs. Other benefits of IXYS' PT IGBTs include higher surge current capabilities, and saturation voltages with negative temperature coefficients, reducing conduction losses with increasing temperature. All these IGBTs are offered as either discrete or "co-packs" with an internal fast recovery diode.

A3-Class Polar IGBT/Diode Types feature 300 V devices with Mid-Frequency Range (15 KHz-40 KHz)

These high current ($I_c=400A$) Polar IGBT/Diode combo co-packs feature extremely low $V_{CE(SAT)}$ for high power, low voltage applications where conduction and switching losses have to be kept at the bare minimum level. The low R_{thJC} further enhances power handling capability.

B2-Class Short-Circuit Rated PT IGBTs with lower $V_{CE(SAT)}$ optimized for Low to Medium Speed Applications

These IGBTs (either discrete or co-packs) find many applications requiring 10 μ s short-circuit withstand capability for implementing electronic overload protection optimized for medium frequency applications (up to 30kHz). They feature low $V_{CE(SAT)}$, low temperature coefficients, and reduced conduction losses at high temperatures. They find applications in AC & DC Motor Drives and Inverters.

Non-Punch Through (NPT) IGBTs Ideal for paralleling, also sometimes preferred for motor drive applications.

"D" Class – IXDxxxx part numbers
600/1200 V rated NPT IGBTs
"E" Class – IXExxxx part numbers
1200 V rated NPT IGBTs

Non-Punch Through³ (NPT³) IGBTs are the Third Generation NPT IGBTs Ideal for extremely critical applications, requiring lowest conduction and switching losses and 10 μ s short-circuit-withstand capability and a positive temp coefficient of $V_{CE(SAT)}$

All these NPT³ IGBTs feature 10 μ s short-circuit-withstand capability and a positive temperature coefficient of $V_{CE(SAT)}$. They feature extremely low E_{on} and E_{off} and very fast turn-off times with negligible tail current.

IXYS Trench IGBTs in the 600 V and 1200 V class for very fast switching applications requiring very low switching times:

Either discrete or co-packaged with ultrafast soft recovery diodes, IXYS Trench IGBTs have lower saturation voltage $V_{CE(sat)}$ and low total switching energy ($E_{on} + E_{off}$). These result in reduced power dissipation and higher power density in a wide range of motion control applications, such as air conditioners, refrigerator compressors, home appliances, AC drives, and circulating pump speed controllers.

Discrete 1700 V IGBTs, (discrete, co-packs and phaselegs) with its proprietary 1800 V SONIC-FRDTM ultrasoft, fast recovery diodes. SonicTM diodes exhibit low temperature dependence, rugged performance, very soft recovery with very low loss/reverse current.

These are rugged NPT devices for very high voltage applications, requiring 10 μ s short circuit withstand capability. They are particularly suitable for high voltage switching applications. IXYS offers its fast switching "A" version 1700 V NPT IGBTs in co-pack and phaseleg configurations for PWM applications with switching frequencies up to 50 kHz. SONIC-FRDTM superior soft recovery characteristics minimize switching noise and eliminate the need for costly snubber circuits.

IXYS BiMOSFETs are devices, which have combined strengths of MOSFETs and IGBTs. Non-epitaxial construction and new fabrication processes were used in making BiMOSFETs a great success.

BiMOSFETs have found many applications, where high voltage (above 1200 V) MOSFETs are desired but unavailable. BiMOSFETs have MOSFET-like characteristics, yet have very low switching and conduction losses as compared to an equally rated MOSFET.

IXYS' unique offering of discrete 2500V and 4000 V VHV IGBTs benefits system designers in high voltage applications. The very high voltage and current ratings of these fast IGBTs, coupled with simple MOS Gate-control, greatly reduce the complexity of high voltage switching. Previously, one had to use series-connected IGBTs with attendant complexity of gate drive circuitry and matched RC networks for dynamic and static equal voltage sharing.

Insulated Gate Bipolar Transistors (IGBT)

The IXLF19N250A comes in an IXYS' ISOPLUS i4-PAC™, while the IXEL40N400 is offered in IXYS' newly designated ISOPLUS i5-PAC™. IXYS' proprietary ISOPLUS discrete packaging improves the simplicity, reliability, and efficiency of high voltage systems. All IXYS' ISOPLUS packages manufactured with an internal DCB isolated substrate are UL registered and provide integral backside case isolation. These packages provide improved creepage distance to simplify compliance with regulatory spacing requirements. Their ceramic substrate enhances device reliability by greatly improving thermal and power cycling. An isolated backside simplifies mounting and with superior isolated thermal impedance. Thermal performance can be further improved by combining IXYS' ISOPLUS package use with clip mounting and next generation phase change interface materials.

IXYS Introduces the Industry's First High Speed Reverse Blocking IGBTs, A New Class Of Power Semiconductors for AC Power Control. These RIGBTs are a new class of devices, with an inherent capability to block voltage in both the forward direction and the reverse direction. The IXRH40N120 can control 40 A continuous and can block 1200 V and comes in the standard TO-247 package. The IXRP15N120 can control 15 A and can block 1200 V. The added feature of reverse blocking does not compromise the performance of the RIGBT as compared to state of the art standard IGBT. The RIGBT features a low voltage drop of 2.2 V typical in the on state and can switch off current in less than 100 ns. These are ideally suited for special applications such as Matrix Converters, Current Fed Converters and Inverters and PFC circuits without front end diode bridges.

IXYS Releases New IGBTs Optimized for Induction Heating Applications:

These devices are ideal for medium switching frequency applications, up to 30 kHz, in hard-switching applications and, up to 100 kHz, in resonant switching applications. These IGBTs can reduce waste heat and improve efficiency in various circuits, particularly induction cooking and heating. The addition of an ultra-fast recovery epitaxial diode (FREDs) makes IXYS' co-pack IGBT exhibit very low reverse recovery charge, which further increases the efficiency of IXYS PT IGBTs. The diodes provided in these IGBTs for induction heating were selected to meet the needs of designers for induction heating and cooking applications, while minimizing the additional cost (and the resulting price) to end customers.

MiniPack 2 - IGBT Modules

CBI

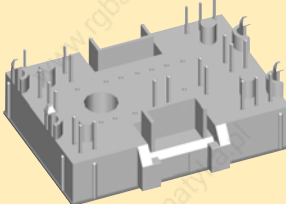
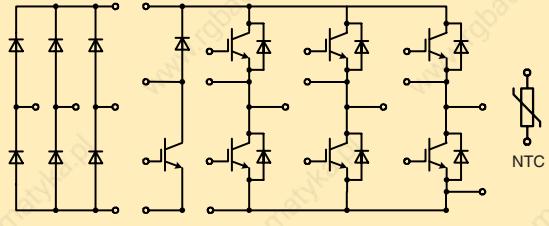

Fig. X110
Outline drawings on page 188 - 224
See data sheet for pin arrangements



Type	Rectifier 3~			V_{CES} V	I_C $T_C = 25^\circ\text{C}$ A	Inverter 3~			V_{CES} V	I_C $T_C = 90^\circ\text{C}$ A	R_{thJC} typ. K/W	
	V_{RRM} V	I_{FAVM} $T_H = 80^\circ\text{C}$ A	R_{thJC} typ. K/W			I_C $T_C = 90^\circ\text{C}$ A	$V_{CE(sat)}$ typ. V	R_{thJC} typ. K/W				Brake chopper
► New												
600 V NPT IGBT												
► MIAA10WB600TMH	1600	62	2.1	600	18	13	2.1	1.8	600	13	1.8	No brake chopper included
► MIAA10WF600TMH	1600	62	2.1	600	18	13	2.1	1.8	600	16	1.6	
► MIAA15WB600TMH	1600	62	2.1	600	23	16	2.1	1.6	600	20	1.3	
► MIAA20WB600TMH	1600	62	2.1	600	29	20	2.1	1.3	600	20	1.3	
600 V Trench IGBT												
► MITA30WB600TMH	1600	90	1.4	600	40	27	1.5	1.4	600	27	1.4	
1200 V Trench IGBT												
► MITA10WB1200TMH	1600	62	2.1	1200	16	11	1.8	2.2	1200	11	2.2	
► MITB10WB1200TMH	1600	62	2.1	1200	17	12	1.9	1.95	1200	12	1.95	
► MITB15WB1200TMH	1600	62	2.1	1200	24	17	1.7	1.6	1200	17	1.6	

CBI

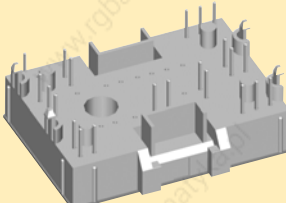
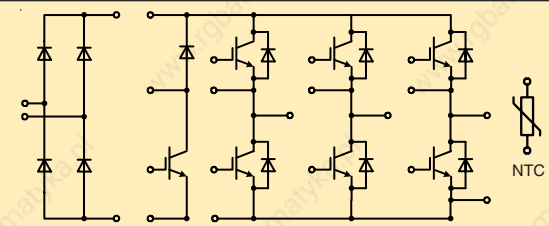

Fig. X110
Outline drawings on page 188 - 224
See data sheet for pin arrangements



Type	Rectifier			V_{CES} V	I_C $T_C = 25^\circ\text{C}$ A	Inverter			V_{CES} V	I_C $T_C = 90^\circ\text{C}$ A	R_{thJC} typ. K/W	
	V_{RRM} V	I_{FAVM} $T_H = 80^\circ\text{C}$ A	R_{thJC} typ. K/W			I_C $T_C = 90^\circ\text{C}$ A	$V_{CE(sat)}$ typ. V	R_{thJC} typ. K/W				Brake chopper
► New												
600 V NPT IGBT												
► MIAA10WE600TMH	1600	23	2.1	600	18	13	2.1	1.8	600	13	1.8	No brake chopper included
► MIAA10WD600TMH	1600	23	2.1	600	18	13	2.1	1.8	600	16	1.6	
► MIAA15WE600TMH	1600	23	2.1	600	23	16	2.1	1.6	600	20	1.3	
► MIAA15WD600TMH	1600	23	2.1	600	23	16	2.1	1.6	600	20	1.3	
► MIAA20WE600TMH	1600	23	2.1	600	29	20	2.1	1.3	600	20	1.3	No brake chopper included
► MIAA20WD600TMH	1600	23	2.1	600	29	20	2.1	1.3	600	20	1.3	No brake chopper included

Nomenclature

M	I	AA	10	WB	600	T	MH	Sample
M								Module
	I							IGBT
		AA						NPT
		TA						Trench standard version
		TB						Trench fast version
			10					Current
				W				Six-Pack
				WB				Six-Pack with 3~ bridge and brake
				WE				Six-Pack with 1~ bridge and brake
					600			Voltage
						T		NTC inside
							MH	MiniPack 2 housing

CBI Modules

CBI = Converter Brake Inverter

three phase rectifier, IGBT brake chopper, three phase IGBT inverter, temperature sensor

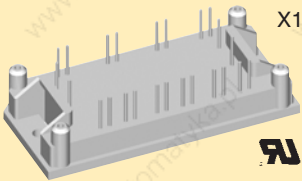
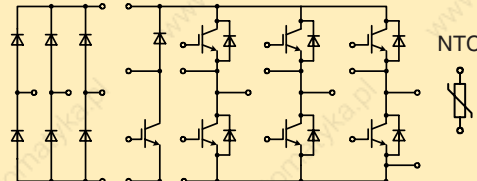
CBI 1 IGBT Modules												
 X111				Package style Outline drawings on page 188 - 224				 NTC				
Type	Rectifier 3~			Inverter 3~					Brake chopper			
	V_{RRM}	I_{DAVM} $T_H = 80^\circ\text{C}$	R_{thJC} typ.	V_{CES}	I_C $T_C = 25^\circ\text{C}$	I_C $T_C = 80^\circ\text{C}$	$V_{CE(sat)}$ typ.	R_{thJC} typ.	V_{CES}	I_C $T_C = 80^\circ\text{C}$	R_{thJC} typ.	
► New	V	A	K/W	V	A	A	V	K/W	V	A	K/W	
600 V NPT IGBT												
MUBW 10-06A6K	1600	61	2.1	600	12	8	2.5	2.8	600	8	2.8	
MUBW 15-06A6K		65	1.9		19	14	2.4	1.7		8	2.8	
MUBW 20-06A6K		65	1.9		25	17	2.0	1.5		8	2.8	
MUBW 25-06A6K		65	1.9		31	21	2.1	1.25		14	1.7	
MUBW 35-06A6K		89	1.4		42	29	2.3	0.95		17	1.5	
1200 V NPT IGBT												
MUBW 15-12A6K	1600	89	1.4	1200	19	13	3.0	1.35	1200	13	1.35	
MUBW 30-12A6K		89	1.4		30	21	3.0	0.95		13	1.35	
1200 V NPT³ IGBT												
► MUBW 30-12E6K	1600	89	1.4	1200	30	21	3.1	0.95	1200	13	1.35	
1200 V Trench IGBT												
► MUBW 45-12T6K	1600	104	1.1	1200	43	31	2.5	0.8	1200	13	1.35	

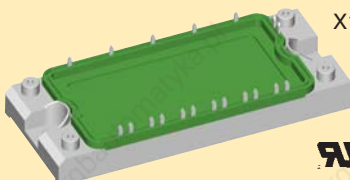
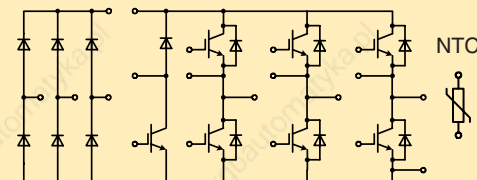
CBI 2 IGBT Modules												
 X112				Package style Outline drawings on page 188 - 224				 NTC				
Type	Rectifier 3~			Inverter 3~					Brake chopper			
	V_{RRM}	I_{DAVM} $T_C = 80^\circ\text{C}$ $d = 1/3$	R_{thJC} max.	V_{CES}	I_C $T_C = 25^\circ\text{C}$	I_C $T_C = 80^\circ\text{C}$	$V_{CE(sat)}$ typ.	R_{thJC} max.	V_{CES}	I_C $T_C = 80^\circ\text{C}$	R_{thJC} max.	
► New	V	A	K/W	V	A	A	V	K/W	V	A	K/W	
600 V NPT IGBT												
MUBW 10-06A7	1600	18	1.5	600	20	15	1.9	1.5	600	15	1.5	
MUBW 15-06A7		18	1.5		25	18	1.9	1.3		15	1.5	
MUBW 20-06A7		24	1.3		35	25	1.9	1.0		18	1.4	
MUBW 30-06A7		24	1.3		50	35	1.9	0.7		18	1.3	
MUBW 50-06A7		29	1.1		75	50	1.9	0.5		25	1.0	
1200 V NPT IGBT												
MUBW 10-12A7	1600	18	1.5	1200	20	15	2.3	1.2	1200	15	1.2	
MUBW 15-12A7		24	1.3		35	25	2.0	0.7		15	1.2	
MUBW 25-12A7		24	1.3		50	35	2.2	0.55		15	1.2	
MUBW 35-12A7		29	1.1		50	35	2.5	0.55		25	0.7	
1200 V NPT³ IGBT												
MUBW 35-12E7	1600	29	1.1	1200	52	36	2.2	0.55	1200	25	0.7	
1200 V Trench IGBT												
► MUBW 15-12T7	1600	24	1.3	1200	25	15	1.7	1.2	1200	15	1.2	
► MUBW 25-12T7		24	1.3		40	25	1.7	0.8		15	1.2	
► MUBW 40-12T7		80	1.3		62	44	2.0	0.6		25	0.7	

CBI Modules

CBI = Converter Brake Inverter

three phase rectifier, IGBT brake chopper, three phase IGBT inverter, temperature sensor

CBI 3
IGBT Modules

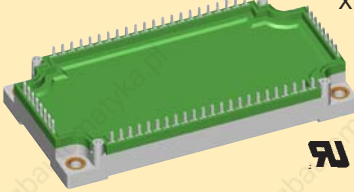

X113



Package style
Outline drawings on page 188 - 224

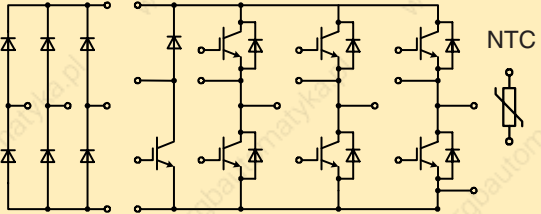

Type	Rectifier 3~			Inverter 3~					Brake chopper		
	V_{RRM}	I_{DAVM} $T_C = 80^\circ\text{C}$ $d = 1/3$	R_{thJC} max.	V_{CES}	I_C $T_C = 25^\circ\text{C}$	I_C $T_C = 80^\circ\text{C}$	$V_{CE(sat)}$ typ.	R_{thJC} max.	V_{CES}	I_C $T_C = 80^\circ\text{C}$	R_{thJC} max.
► New	V	A	K/W	V	A	A	V	K/W	V	A	K/W
600 V NPT IGBT											
MUBW 50-06A8	1600	40	1.1	600	75	50	1.9	0.5	600	25	1.0
MUBW 75-06A8		46	0.94		100	65	2.0	0.39		35	0.75
MUBW 100-06A8		60	0.73		125	85	1.9	0.3		50	0.55
1200 V NPT IGBT											
MUBW 35-12A8	1600	27	1.3	1200	50	35	2.5	0.55	1200	25	0.7
MUBW 50-12A8		46	0.94		85	60	2.2	0.35		35	0.55
1200 V NPT³ IGBT											
MUBW 50-12E8	1600	50	0.94	1200	90	62	1.9	0.35	1200	35	0.55
1200 V Trench IGBT											
► MUBW 50-12T8	1600	50	0.94	1200	75	50	1.7	0.45	1200	35	0.55
► MUBW 75-12T8		50	0.94		105	75	1.7	0.35		35	0.55
1700 V Trench IGBT											
► MUBW 50-17T8	2200	120	1.1	1700	74	53	2.0	0.43	1700	34	0.62
► MUBW 75-17T8		140	0.95		113	80	2.0	0.28		34	0.62

Gate Driver Board GDBD 4410

Drives 7 Gates of a Converter – Brake – Inverter IGBT Power Module for Industrial Applications

GDBD 4410 simplifies driving CBI2 and CBI3 module types. Pin locations of the driver board match that of the CBI modules. Thus it can be mounted very close to the gate control pins of the module, providing the shortest possible traces from driver to the gate and an easy routing on the main inverter board. GDBD4410 is a fast and easy to use solution and ideal for small and medium inverter series.

Main features are:

- Drives CBI modules up to 100A/600V and 50A/1200V
- Driver for brake IGBT included
- Design is based on IXBD4410/11 chipset
- High output gate current up to $\pm 2\text{A}$ peak per gate
- Integrated charge pump for negative gate drive to speed up IGBT turn off and the suppress spurious gate noise triggering
- Noise immune pulse transformer for high dV/dt applications ($>50\text{kV}/\mu\text{s}$)
- $V_{CE(sat)}$ sensing for short circuit protection
- Failure status signal
- Ground referenced and TTL/CMOS compatible interface for control signals
- +15V unipolar power supply required
- Operating frequency up to 25 kHz

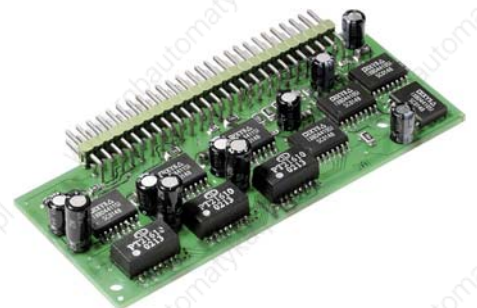

IGBT Modules - Six-Pack configuration

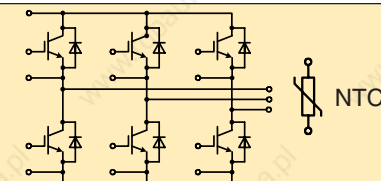
Six-Pack IGBT Modules		X111 Package style Outline drawings on page 188 - 224 See data sheet for pin arrangements								
Type	V_{CES} V	I_{C25} A $T_C = 25^\circ\text{C}$ IGBT	I_{C80} A $T_C = 80^\circ\text{C}$ IGBT	$V_{CE(sat)}$ typ V $T_J = 25^\circ\text{C}$ IGBT	E_{off} mJ $T_J = 125^\circ\text{C}$ IGBT	$R_{th,JC}$ K/W IGBT	I_{F25} A $T_C = 25^\circ\text{C}$ diode	I_{F80} A $T_C = 80^\circ\text{C}$ diode	NTC inside	
600 V PT IGBT										
► MWI 60-06G6K	600	60	41	2.3	0.5	0.7	48	33	yes	
1200 V NPT IGBT										
► MWI 15-12A6K	1200	19	13	3.0	1.1	1.37	24	16	yes	
1200 V NPT³ IGBT										
► MWI 30-12E6K	1200	29	21	2.5	1.8	0.95	24	16	yes	
► MWI 50-12E6K		51	36	2.4	2.6	0.6	49	32	yes	
1200 V Trench IGBT										
► MWI 45-12T6K	1200	43	31	1.9	3.4	0.8	49	32	yes	
► MWI 60-12T6K		58	41	1.9	4.8	0.62	49	32	yes	
► MWI 80-12T6K		80	56	2.0	6.5	0.46	80	51	yes	

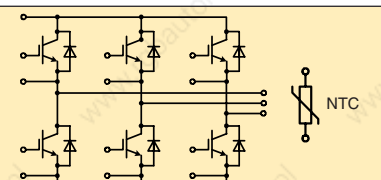
Six-Pack IGBT Modules		X112 Package style Outline drawings on page 188 - 224								
Type	V_{CES} V	I_{C25} A $T_C = 25^\circ\text{C}$ IGBT	I_{C80} A $T_C = 80^\circ\text{C}$ IGBT	$V_{CE(sat)}$ typ V $T_J = 25^\circ\text{C}$ IGBT	E_{off} mJ $T_J = 125^\circ\text{C}$ IGBT	$R_{th,JC}$ K/W IGBT	I_{F25} A $T_C = 25^\circ\text{C}$ diode	I_{F80} A $T_C = 80^\circ\text{C}$ diode	NTC inside	
600 V NPT IGBT										
MWI 30-06A7	600	45	30	1.9	1.0	0.88	36	24	optional	
MWI 50-06A7		75	50	1.9	1.7	0.55	72	45	optional	
MWI 75-06A7		90	60	2.1	2.5	0.44	140	85	optional	
1200 V NPT IGBT										
MWI 15-12A7	1200	30	20	1.0	1.8	0.88	25	17	no	
MWI 25-12A7		50	35	2.2	2.8	0.55	50	33	optional	
MWI 35-12A7		62	44	2.2	4.2	0.44	50	33	optional	
MWI 50-12A7		85	60	2.2	5.6	0.35	110	70	optional	
1200 V NPT³ IGBT										
► MWI 25-12E7	1200	52	36	1.9	2.5	0.55	50	33	no	
► MWI 50-12E7		90	62	2.1	4.0	0.35	110	70	no	
1200 V Trench IGBT										
► MWI 50-12T7	1200	75	50	1.7	6.5	0.49	110	70	yes	
► MWI 75-12T7		105	75	1.7	9.5	0.35	150	100	yes	

IGBT Modules - Six-Pack configuration

Six-Pack
IGBT Modules

X113

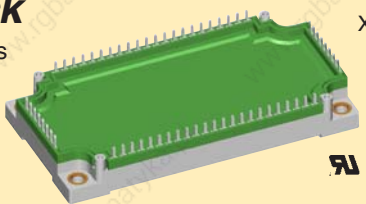

Package style
Outline drawings on page 188 - 224

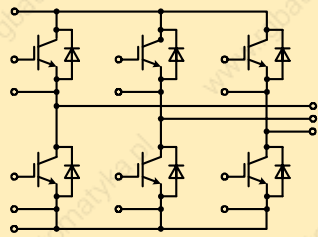

► New

Type	V_{CES} V	I_{C25} A $T_C = 25^\circ\text{C}$ IGBT	I_{C80} A $T_C = 80^\circ\text{C}$ IGBT	$V_{CE(sat)}$ typ V $T_J = 25^\circ\text{C}$ IGBT	E_{off} mJ $T_J = 125^\circ\text{C}$ IGBT	R_{thJC} K/W IGBT	I_{F25} A $T_C = 25^\circ\text{C}$ diode	I_{F80} A $T_C = 80^\circ\text{C}$ diode	NTC inside
600 V NPT IGBT									
MWI 100-06A8	600	130	88	2.0	2.9	0.3	140	88	optional
MWI 150-06A8		170	115	2.0	4.6	0.24	210	130	optional
MWI 200-06A8		215	155	2.0	6.3	0.18	260	165	optional
1200 V NPT IGBT									
MWI 75-12A8	1200	125	85	2.2	10.5	0.25	150	100	optional
MWI 100-12A8		160	110	2.2	14.6	0.19	200	130	optional
1200 V NPT³ IGBT									
MWI 75-12E8	1200	130	90	2.0	7.5	0.25	150	100	no
MWI 100-12E8		165	115	2.0	10.0	0.19	200	130	no
1200 V Trench IGBT									
► MWI 75-12T8	1200	100	75	1.7	9.5	0.35	150	100	yes
► MWI 100-12T8		140	100	1.7	12.0	0.26	200	130	yes
► MWI 150-12T8		200	150	1.7	17.0	0.18	tbd	tbd	yes

Six-Pack
IGBT Modules

X114

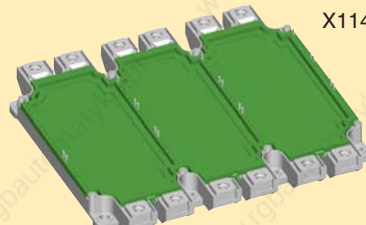

Package style
Outline drawings on page 188 - 224

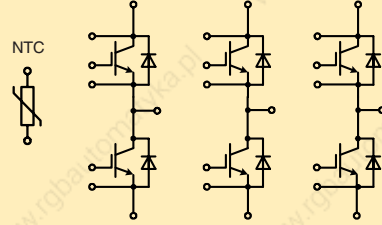

NTC

► New

Type	V_{CES} V	I_{C25} A $T_C = 25^\circ\text{C}$ IGBT	I_{C80} A $T_C = 80^\circ\text{C}$ IGBT	$V_{CE(sat)}$ typ V $T_J = 25^\circ\text{C}$ IGBT	E_{off} mJ $T_J = 125^\circ\text{C}$ IGBT	R_{thJC} K/W IGBT	I_{F25} A $T_C = 25^\circ\text{C}$ diode	I_{F80} A $T_C = 80^\circ\text{C}$ diode	NTC inside
1200 V NPT³ IGBT									
► MWI 225-12E9	1200	355	250	2.1	20	0.09		205	yes
► MWI 300-12E9		530	375	2.0	30	0.06		300	yes
► MWI 450-12E9		640	440	2.2	45	0.057		450	yes
1700 V NPT³ IGBT									
► MWI 225-17E9	1700	335	235	2.5	54	0.085		200	yes
► MWI 300-17E9		500	350	2.3	80	0.057		290	yes
► MWI 450-17E9		580	405	2.25	90	0.057		450	yes

IGBT Modules - Full Bridge configuration

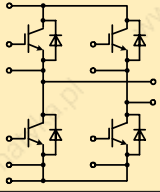
Full Bridge IGBT Modules		X112		Package style		Outline drawings on page 188 - 224			
Type	V_{CES} V	I_{C25} A 25°C IGBT	I_{C80} A 80°C IGBT	$V_{CE(sat)}$ typ V 25°C IGBT	E_{off} mJ 125°C IGBT	R_{thJC} K/W IGBT	I_{F25} A 25°C diode	I_{F80} A 80°C diode	
600 V NPT IGBT									
MKI 50-06A7 MKI 75-06A7	600	72 90	50 60	1.9 2.1	1.7 2.5	0.55 0.44	72 140	45 85	
1200 V Fast NPT IGBT									
► MKI 50-12F7	1200	65	45	3.2	2.5	0.35	110	70	
1200 V NPT³ IGBT									
► MKI 50-12E7	1200	90	62	1.9	4.0	0.35	110	70	

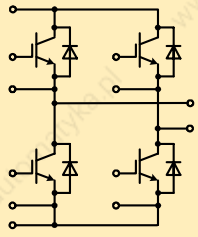

Full Bridge IGBT Modules		X113		Package style		Outline drawings on page 188 - 224			
Type	V_{CES} V	I_{C25} A $T_C = 25^\circ\text{C}$ IGBT	I_{C80} A $T_C = 80^\circ\text{C}$ IGBT	$V_{CE(sat)}$ typ V $T_J = 25^\circ\text{C}$ IGBT	E_{off} mJ $T_J = 125^\circ\text{C}$ IGBT	R_{thJC} K/W IGBT	I_{F25} A $T_C = 25^\circ\text{C}$ diode	I_{F80} A $T_C = 80^\circ\text{C}$ diode	
1200 V Fast NPT IGBT									
► MKI 100-12F8	1200	125	85	3.3	5.0	0.19	200	130	
1200 V NPT³ IGBT									
MKI 75-12E8 MKI 100-12E8	1200	130 165	90 115	2.0 2.0	7.5 10.0	0.25 0.19	150 200	100 130	

IGBT Modules

NPT IGBT Modules

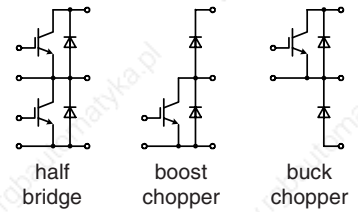
NPT IGBT = non-punch through insulated gate bipolar transistor, square RBSOA, short circuit rated

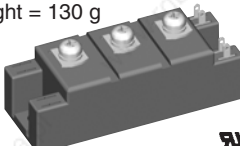
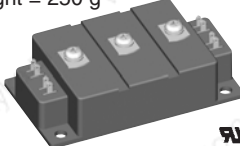

Type	V _{CES} V	I _{C25} A T _C = 25°C IGBT	I _{C80} A T _C = 80°C IGBT	V _{CE(sat) typ} V T _J = 25°C IGBT	E _{off} mJ T _J = 125°C IGBT	R _{thJC} K/W IGBT	I _{F25} A T _C = 25°C diode	I _{F80} A T _C = 80°C diode	Thermistor	Fig. No.	Package style	
<p>► New</p> <p>Outline drawings on page 188 - 224</p>												
1200 V Half Bridge												
MII 75-12A3	1200	90	60	2.2	5.6	0.33	100	60		X127a	X127a/b/c Weight = 130 g 	
MII 100-12A3	1200	135	90	2.2	10.5	0.22	150	100		X127a		
MII 145-12A3	1200	160	110	2.2	15.0	0.18	150	100		X127a		
MII 150-12A4	1200	180	120	2.2	11.5	0.17	200	130		X128a		
MII 200-12A4	1200	270	180	2.2	21.0	0.11	300	200		X128a		
MII 300-12A4	1200	330	220	2.2	29.0	0.09	450	270		X128a		
1200 V Boost chopper												
MID 75-12A3	1200	90	60	2.2	5.6	0.33	100	60		X127b	Gate connection arrangement see data sheet X128a/b/c/d Weight = 250 g 	
MID 100-12A3	1200	135	90	2.2	10.5	0.22	150	100		X127b		
MID 145-12A3	1200	160	110	2.2	15.0	0.18	150	100		X127b		
MID 150-12A4	1200	180	120	2.2	11.5	0.17	200	130		X128b		
MID 200-12A4	1200	270	180	2.2	21.0	0.11	300	200		X128b		
MID 300-12A4	1200	330	220	2.2	29.0	0.09	450	270		X128b		
MID 550-12A4	1200	670	460	2.3	59.0	0.05	750	460		X128b		
1200 V Buck chopper												
MDI 75-12A3	1200	90	60	2.2	5.6	0.33	100	60		X127c	Gate connection arrangement see data sheet X130a/b/c Weight = 250 g 	
MDI 100-12A3	1200	135	90	2.2	10.5	0.22	150	100		X127c		
MDI 145-12A3	1200	160	110	2.2	15.0	0.18	150	100		X127c		
MDI 150-12A4	1200	180	120	2.2	11.5	0.17	200	130		X128c		
MDI 200-12A4	1200	270	180	2.2	21.0	0.11	300	200		X128c		
MDI 300-12A4	1200	330	220	2.2	29.0	0.09	450	270		X128c		
MDI 550-12A4	1200	670	460	2.3	59.0	0.05	750	460		X128c		
1200 V Half Bridge with 3rd generation NPT³												
MII 400-12E4	1200	420	300	2.2	30.0	0.08	450	290		X130a	Gate connection arrangement see data sheet	
1200 V Boost chopper with 3rd generation NPT³												
MID 400-12E4 ①	1200	420	300	2.2	30.0	0.08	450	290		X130b		
1200 V Buck chopper with 3rd generation NPT³												
MDI 400-12E4 ①	1200	420	300	2.2	30.0	0.08	450	290		X130c	Gate connection arrangement see data sheet	

① I_{F80} of IGBT free wheeling diode: 95 A

ISOPLUS i4-PAC™ Package

- isolated back surface (DCB)
- low inductive path
- high reliability

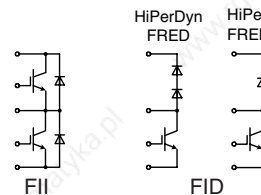

NPT IGBT Modules in i4-PAC

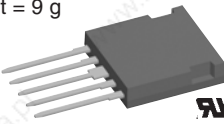
Type	Configu-ration	Technology	V _{CES} V	I _{C25} @ 25°C A	I _{C80} @ 90°C A	V _{CE(sat) typ.} T _C = 25°C	Fig. No.	Package style
<p>► New</p> <p>Weight = 9 g</p> 								
FII 30-06D	phaseleg	NPT IGBT	600	30	18	1.9	X024a	ISOPLUS i4-PAC™
FII 40-06D	phaseleg	NPT IGBT	600	40	25	1.8		
FII 30-12E	phaseleg	NPT ³ IGBT	1200	32	20	2.4		
FII 50-12E	phaseleg	NPT ³ IGBT	1200	50	32	2.0		
FID 35-06C	boost	NPT IGBT & HiPerDynFRED	600	38	24	1.9		
FID 36-06D	boost	NPT IGBT & HiPerFRED	600	38	24	1.9		
FID 60-06D	boost	NPT IGBT & HiPerFRED	600	65	40	1.6		

IGBT Modules

NPT³ IGBT Modules

- low loss and smooth switching
- AlSiC base plate for high power cycling capacity
- AlN substrate for low thermal resistance

High Power Single Switch

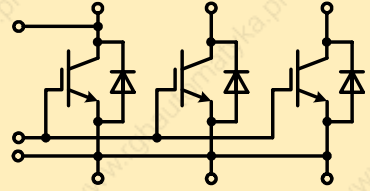

Type	V_{CES} V	I_{C25} A $T_c = 25^\circ\text{C}$ IGBT	I_{C80} A $T_c = 80^\circ\text{C}$ IGBT	$V_{CE(sat)}$ typ V $T_J = 25^\circ\text{C}$ IGBT	E_{off} mJ $T_J = 125^\circ\text{C}$ IGBT	R_{thJC} K/W IGBT	I_{F25} A $T_c = 25^\circ\text{C}$ diode	I_{F80} A $T_c = 80^\circ\text{C}$ diode	Fig. No.
► New									
MIO 1800-17E10	1700	2500	1800	2.3	670	0,009	tbd	1800	X134
MIO 2400-17E10	1700	3300	2400	2.3	980	0,007		2400	
► MIO 1200-25E10	2500	1650	1200	2.5	1250	0,009		1200	
► MIO 1500-25E10	2500	2100	1500	2.7	1450	0,008		1500	
MIO 1200-33E10	3300	1650	1200	3.1	1950	0,0085		1200	

High Voltage Package with enlarged strike and creepage distance

► MIO 1200-33E11	3300	1650	1200	3.1	2000	0,0085	tbd	1200	X135
► MIO 600-65E11	6500	840	600	4.2	3500	0,011		600	

Package style

Outline drawings on page 188 - 224

X134
Weight = 1500 g

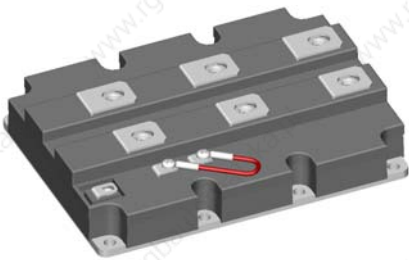

X135
Weight = 1500 g



IGBT Modules

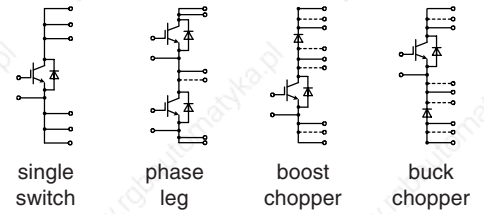

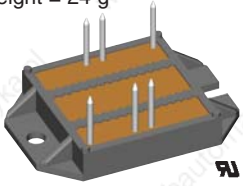
Type	V_{CES}	I_{C25} $T_C = 25\text{ }^\circ\text{C}$	I_{C80} $T_C = 80\text{ }^\circ\text{C}$	$V_{CE(sat)}$ typical $T_J = 25\text{ }^\circ\text{C}$	$t_{d(on)}$ $t_{d(off)}$ delay time Switching Character- istics	R_{thJC} per IGBT	I_{F25} $T_J = 25\text{ }^\circ\text{C}$ diode A	I_{F80} $T_J = 80\text{ }^\circ\text{C}$ diode A	R_{thJC} per diode K/W	Fig. No.	Package style		
► New	V	IGBT A	IGBT A	IGBT V	ns	K/W	A	A	K/W		Outline drawings on page 188 - 224		
Single switch modules													
VIO 25-06P1 VIO 25-12P1	600 1200	25 30	17 21	2.4 2.6	30 270 100 500	1.5 0.95	19 26	12 17	3.5 2.3	X102	ECO-PAC 2 Weight = 24 g  See data sheet for pin arrangement		
VIO 50-06P1 VIO 50-12P1	600 1200	43 49	29 33	2.4 3.1	50 270 100 500	0.95 0.6	39 49	19 31	2.3 1.3				
VIO 75-06P1 VIO 75-12P1	600 1200	69 92	48 62	2.3 2.7	50 300 100 500	0.6 0.33	56 103	35 65	1.3 0.66				
VIO 100-06P1 VIO 125-12P1	600 1200	93 138	63 94	2.4 2.8	150 450 100 650	0.43 0.22	132 154	82 97	0.66 0.45				
VIO 130-06P1 VIO 160-12P1	600 1200	121 169	83 117	2.3 2.9	25 150 100 600	0.33 0.18	134 154	82 97	0.66 0.45				
Phase leg modules													
VII 25-06P1 VII 25-12P1	600 1200	25 30	17 21	2.4 2.6	30 270 100 500	1.5 0.95	19 26	12 17	3.5 2.3				
VII 50-06P1 VII 50-12P1	600 1200	43 49	29 33	2.4 3.1	50 270 100 500	0.95 0.6	39 49	19 31	2.3 1.3				
VII 75-06P1 VII 75-12P1	600 1200	69 92	48 62	2.3 2.7	50 300 100 500	0.6 0.33	56 103	35 65	1.3 0.66				
VII 100-06P1	600	93	63	2.4	150 450	0.43	132	82	0.66				
VII 130-06P1	600	121	83	2.3	25 150	0.33	134	82	0.66				
Boost chopper modules													
VID 25-06P1 VID 25-12P1	600 1200	25 30	17 21	2.4 2.6	30 270 100 500	1.5 0.95	19 26	12 17	3.5 2.3				
VID 50-06P1 VID 50-12P1	600 1200	43 49	29 33	2.4 3.1	50 270 100 500	0.95 0.6	39 49	19 31	2.3 1.3				
VID 75-06P1 VID 75-12P1	600 1200	69 92	48 62	2.3 2.7	50 300 100 500	0.6 0.33	56 103	35 65	1.3 0.66				
VID 100-06P1 VID 125-12P1	600 1200	93 138	63 94	2.4 2.8	150 450 100 650	0.43 0.22	132 154	82 97	0.66 0.45				
VID 130-06P1 VID 160-12P1	600 1200	121 169	83 117	2.3 2.9	25 150 100 600	0.33 0.18	134 154	82 97	0.66 0.45				
Buck chopper modules													
VDI 25-06P1 VDI 25-12P1	600 1200	25 30	17 21	2.4 2.6	30 270 100 500	1.5 0.95	19 26	12 17	3.5 2.3				
VDI 50-06P1 VDI 50-12P1	600 1200	43 49	29 33	2.4 3.1	50 270 100 500	0.95 0.6	39 49	19 31	2.3 1.3				
VDI 75-06P1 VDI 75-12P1	600 1200	69 92	48 62	2.3 2.7	50 300 100 500	0.6 0.33	56 103	35 65	1.3 0.66				
VDI 100-06P1 VDI 125-12P1	600 1200	93 138	63 94	2.4 2.8	150 450 100 650	0.43 0.22	132 154	82 97	0.66 0.45				
VDI 130-06P1 VDI 160-12P1	600 1200	121 169	83 117	2.3 2.9	25 150 100 600	0.33 0.18	134 154	82 97	0.66 0.45				

IGBT Modules

IGBT Modules - Full Bridge configuration

Type	V_{CES} V	I_{C25} A $T_C = 25^\circ C$ IGBT	I_{C80} A $T_C = 80^\circ C$ IGBT	$V_{CE(sat) typ}$ V $T_J = 25^\circ C$ IGBT	E_{off} mJ $T_J = 125^\circ C$ IGBT	R_{thJC} K/W IGBT	I_{F25} A $T_C = 25^\circ C$ diode	I_{F80} A $T_C = 80^\circ C$ diode	Circuit diagram	Fig. No.
► New										
VKI 50-06P1	600	45	30	1.9	1.0	0.88	36	24	A	X102
VKI 75-06P1	600	72	50	1.9	1.7	0.55	72	45		
VKI 50-12P1	1200	50	35	2.5	2.8	0.55	50	35		

Further modules see page 68 "IGBT Modules - Full Bridge Configuration"

Six- Pac in ECO-PAC

Type	V_{CES} V	I_{C25} A $T_C = 25^\circ C$ IGBT	I_{C80} A $T_C = 80^\circ C$ IGBT	$V_{CE(sat) typ}$ V $T_J = 25^\circ C$ IGBT	E_{off} mJ $T_J = 125^\circ C$ IGBT	R_{thJC} K/W IGBT	I_{F25} A $T_C = 25^\circ C$ diode	I_{F80} A $T_C = 80^\circ C$ diode	Circuit diagram	Fig. No.
► New										
VWI 20-06P1	600	19	14	1.9	0.3	1.7	21	14	B	X102
VWI 35-06P1	600	35	25	1.9	0.68	1.0	35	24		
VWI 15-12P1	1200	18	14	2.3	1.1	1.2	12	8		
VWI 6-12P1	1200	6	4.1	3.9	0.2	3.1	12	8		
VWI 3x20-06P1*	600	20	15	1.9	0.3	1.5	20	15	C	X101

* NTC optional

Package style

Outline drawings on page 188 - 224

X101 ECO-PAC 1

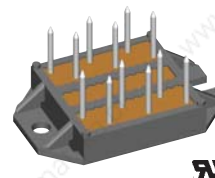

X102 ECO-PAC 2



See data sheet for pin arrangements

Circuit diagrams

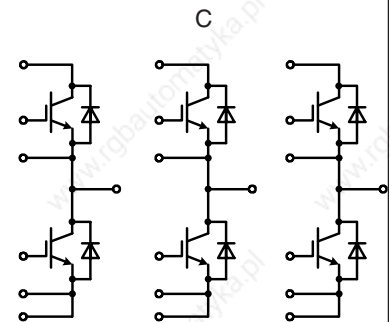
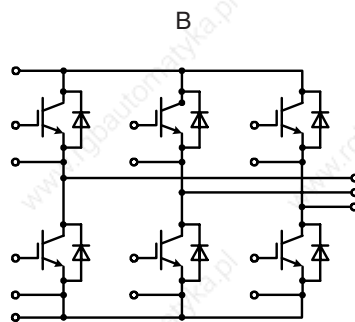
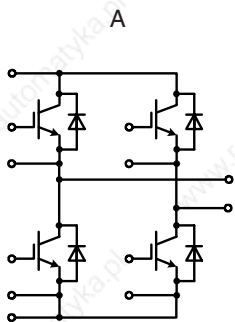



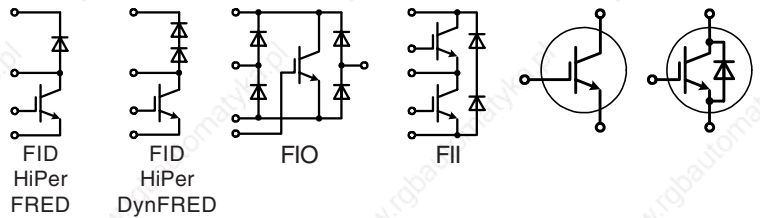

Discrete NPT IGBT

NPT IGBT

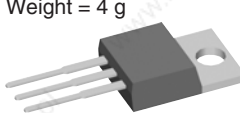
NPT IGBT = non-punch through insulated gate bipolar transistor, square RBSOA, short circuit rated

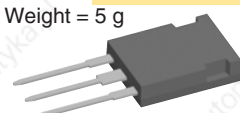

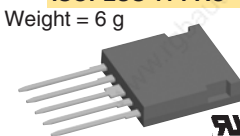

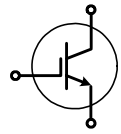

Type	V _{CEsat} V	I _{C25} A T _C = 25 °C IGBT	I _{C90} A T _C = 90 °C IGBT	V _{CEsat} V T _J = 25 °C IGBT	E _{off} mJ T _J = 125 °C IGBT	R _{thJC} K/W max. IGBT	Diode	I _{F90} A T _C = 90 °C diode	Fig. No.	Package style		
<p>► New</p> <p>Outline drawings on pages 188 - 224</p>												
IXDP20N60B	600	32	20	2.2	0.4	0.9	●	14	X005a	TO-220AB Weight = 4 g 		
IXDP20N60BD1		32	20	2.2	0.4	0.9			X005a			
IXDP35N60B		60	35	2.1	0.8	0.5			X005a			
IXDH35N60B		60	35	2.1	0.8	0.5			X014a			
IXDH35N60BD1		60	35	2.1	0.8	0.5			X014a			
IXDR35N60BD1	60	24	2.1	0.8	1.0	●	18	X016a				
IXDA20N120AS	1200	34	25	2.8	2.4	0.63	●	20	X011b	TO-263AA Weight = 2 g 		
IXDH20N120		38	25	2.4	2.4	0.63			X014a			
IXDH20N120D1		38	25	2.4	2.4	0.63			X014a			
IXDH30N120		60	38	2.4	3.4	0.42			X014a			
IXDH30N120D1		60	38	2.4	3.4	0.42			●		35	X014a
IXDR30N120		50	30	2.4	3.4	0.60			●		27	X016a
IXDR30N120D1		50	30	2.4	3.4	0.60			●		27	X016a
IXDN55N120D1	100	62	2.3	6.2	0.28	●	60	X027a				
IXDN75N120	150	95	2.2	10.5	0.19	●	60	X027a				
<p>3rd generation NPT³ IGBT lower V_{CE(sat)}</p>												
IXEH25N120	1200	36	24	2.6	2.5	0.63	●	20	X014a	ISOPLUS247™ Weight = 5 g 		
IXEH25N120D1		36	24	2.6	2.5	0.63			X014a			
IXER35N120D1		50	32	2.2	2.6	0.60			●		25	X016a
IXEH40N120		60	40	2.4	3.0	0.42			●		35	X014a
IXEH40N120D1		60	40	2.4	3.0	0.42						X014a
IXER60N120		95	60	2.1	4.8	0.33			●		60	X016a
IXEN60N120		100	65	2.1	4.8	0.28						X027a
IXEN60N120D1	100	65	2.1	4.8	0.28	●	60	X027a				
<p>Special configurations with NPT IGBT</p>												
Type	Configuration	V _{CEsat} V	I _{C25} A T _C = 25 °C IGBT	I _{C90} A T _C = 90 °C IGBT	V _{CEsat} V T _J = 25 °C IGBT	E _{off} mJ T _J = 125 °C IGBT	R _{thJC} K/W max. IGBT	Fig. No.				
FID35-06C	boost, HiPerDynFRED	600	38	24	1.9	0.6	1.0	X024a				
FID36-06D	boost, HiPerDynFRED	600	38	24	1.9	0.6	1.0					
FID60-06D	boost, HiPerDynFRED	600	65	40	1.6	1.4	0.6					
FII30-06D	phaseleg	600	30	18	1.9	0.68	1.25					
FII40-06D	phaseleg	600	40	25	1.8	0.8	1.0					
<p>Special configurations with NPT³ IGBT</p>												
FII30-12E	phaseleg	1200	32	20	2.4	2.0	0.8	X024a				
FII50-12E	phaseleg	1200	50	32	2.0	2.2	0.6					
FIO50-12BD	1~ bridge & IGBT	1200	50	32	2.0	2.2	0.6					

S Series IGBTs with SCSOA Capability

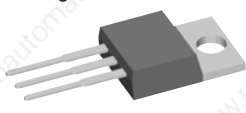

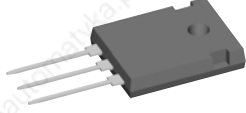
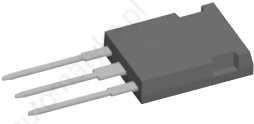
Medium speed (1 kHz to 20 kHz) Single IGBT

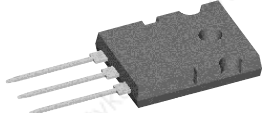

Part Type	V _{CES} max V	I _C max T _C =25°C A	I _C max T _C =90°C A	V _{CE(sat)} max T _C =25°C V	t _{ri} typ T _J =25°C ns	E _{off} typ T _J =125°C mJ	R _{thJC} max IGBT	Fig. No	Package style
IXSP24N60B	600	40	24	2.5	170	-	-	X005a	Outline drawings on pages 188 - 224 X005a TO-220AB Weight = 4 g  X011b TO-263AA Weight = 2 g  X014a TO-247AD Weight = 6 g  X015 PLUS247 Weight = 5 g  X019 TO-268AA  X020 TO-264 Weight = 10 g 
IXSH24N60B		48	24	2.5	170	1.3	0.83	X014a	
IXST24N60B		48	24	2.5	170	1.3	0.83	X019	
IXSH30N60B		55	30	2	140	2.5	0.62	X014a	
IXSH30N60C		55	30	2.5	70	1.2	0.62	X014a	
IXST30N60B		55	30	2	140	2.5	0.62	X019	
IXST30N60C		55	30	2.5	70	1.2	0.62	X019	
IXSH40N60B		75 ①	40	2.2	120	1.8	0.45	X014a	
IXSH50N60B		75 ①	50	2.5	150	3.3	0.5	X014a	
IXST40N60B		75 ①	40	2.2	120	1.8	0.45	X019	
IXSK80N60B		160 ①	80	2.5	180	4.2	0.26	X020	
IXSX80N60B		160 ①	80	2.5	180	4.2	0.26	X015	
IXSA15N120B	1200	30	15	3.4	160	3.1	0.83	X011b	
IXSP15N120B		30	15	3.4	160	3.1	0.83	X005a	
IXSH15N120B		30	15	3.4	126	3.1	0.83	X014a	
IXST15N120B		30	15	3.4	126	3.1	0.83	X019	
IXSH35N120B		70	35	3.6	180	9	0.42	X014a	
IXST35N120B		70	35	3.6	180	9	0.42	X019	
IXSH45N120B		75 ①	45	3	380	13	0.42	X014a	
IXST45N120B		75 ①	45	3	380	13	0.42	X019	
IXSH35N140A	1400	70	35	4	400	12	0.42	X014a	

① Currents may be limited by external package leads.

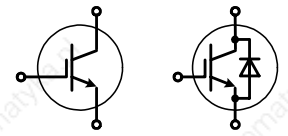
Discrete IGBT S series with SCSOA capability



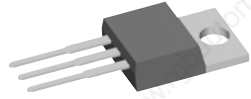

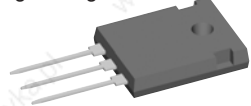
Medium Speed (1 kHz to 20 kHz), IGBT with freewheeling diode

Part Type	V _{CES} max	I _c max T _c =25°C	I _c max T _c =110°C	V _{CE(sat)} max T _c =25°C	t _{fi} typ T _J =25°C	E _{off} typ T _J =125°C	R _{thJC} max IGBT	I _F 110°C Diode	R _{thJC} Diode	Fig. No	Package style
► New	V	A	A	V	ns	mJ		A	K/W		Outline drawings on pages 188 - 224
► IXSA10N60B2D1	600	20	10	2.5	165	0.79	1.25	11	2.5	X011b	TO-220AB X005a Weight = 4 g 
► IXSP10N60B2D1		20	10	2.5	165	0.79	1.25	11	2.5	X005a	
► IXSQ10N60B2D1		20	10	2.5	165	0.79	1.25	11	2.5	X017a	
► IXSH10N60B2D1		20	10	2.5	165	0.79	1.25	11	2.5	X014a	
► IXSA20N60B2D1		35	20	2.5	126	0.97	0.66	11	2.5	X011b	
► IXSP20N60B2D1		35	20	2.5	126	0.97	0.66	11	2.5	X005a	
► IXSQ20N60B2D1		35	20	2.5	126	0.97	0.66	21	1.6	X019	
► IXSH20N60B2D1		35	20	2.5	126	0.97	0.66	21	1.6	X014a	
► IXSH30N60B2D1		48	30	2.5	140	1.18	0.5	28	0.9	X014a	
► IXST30N60B2D1		48	30	2.5	140	1.18	0.5	28	0.9	X019	
► IXSH40N60B2D1	600	75 ①	40	1.7	82	0.4	0.42	30	0.9	X014a	X011b TO-263AA Weight = 2 g 
► IXST40N60B2D1		75 ①	40	1.7	82	0.4	0.42	30	0.9	X019	
IXSH15N120BD1	1200	30	15	3.4	150	1.5	0.83	15	0.9	X014a	X014a TO-247AD Weight = 6 g 
IXST15N120BD1		30	15	3.4	150	1.5	0.83	15	0.9	X019	
IXSK35N120BD1		70	35	3.6	180	5	0.42	35	0.65	X020	
IXSR35N120BD1		70	30	3.6	180	5	0.5	30	0.83	X016a	
IXSX35N120BD1		70	35	3.6	180	5	0.42	35	0.65	X015	

① Currents may be limited by external package leads.

Discrete IGBT G Series

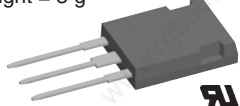
Low Saturation Voltage Types, single IGBT

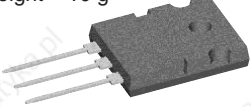
Part Type	V _{CES} max	I _c max T _c =25°C	I _c max T _c =90°C	V _{CE(sat)} max T _c =25°C	t _{fi} typ T _J =25°C	E _{off} typ T _J =125°C	R _{thJC} max	Fig. No	Package style
► New	V	A	A	V	ns	mJ	K/W		
IXGH60N60	600	75 ①	60	1.7	360	17	0.42	X014a	X016a ISOPLUS247™ Weight = 5 g 
IXGK60N60		75	60	1.7	360	17	0.42	X020	
IXGT60N60		75 ①	60	1.7	360	17	0.42	X019	
IXGN60N60		100	60	1.7	360	17	0.5	X027a	
► IXGN80N60A2		160 ①	80 ②	1.35	250	10	0.2	X027a	
IXGN200N60A2		200 ①	100 ②	1.35	250	12	0.17	X027a	
IXGA8N100	1000	16	8	2.7	390	3.7	2.3	X011b	X019 TO-268AA Weight = 5 g 
IXGP8N100		16	8	2.7	390	3.7	2.3	X005a	
IXGA20N100		40	20	3	280	3.5	0.83	X011b	
IXGP20N100		40	20	3	280	3.5	0.83	X005a	
IXGH20N100		40	20	3	280	3.5	0.83	X014a	
IXGT20N100		40	20	3	280	3.5	0.83	X019	
IXGA20N120	1200	40	20	2.5	380	9.5	0.83	X011b	X020 TO-264 Weight = 10 g 
IXGP20N120		40	20	2.5	380	9.5	0.83	X005a	
IXGH20N120		40	20	2.5	380	9.5	0.83	X014a	
IXGT20N120		40	20	2.5	380	9.5	0.83	X019	
► IXGH40N120A2		75 ①	50	2	800	35	0.35	X014a	
► IXGT40N120A2		75 ①	50	2	800	35	0.35	X019	

① Currents may be limited by external package leads.

② @ T_c=110°C

X027a **SOT-227B miniBLOC**
Weight = 30 g

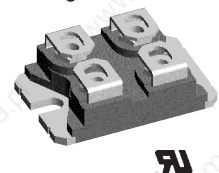

Discrete IGBT G Series

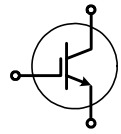

Mid-Frequency Range (15 kHz - 40 kHz) single IGBT

Part Type	V _{CES} max	I _C max T _C =25°C	I _C max T _C =110°C	V _{CE(sat)} max T _C =25°C	t _{fi} typ T _J =25°C	E _{off} typ T _J =125°C	R _{thJC} max	Fig. No	Package style
► New	V	A	A	V	ns	mJ	K/W		Outline drawings on pages 188 - 224
IXGA7N60B	600	14	7 ③	2	150	0.6	2.3	X011b	X005a Weight = 4 g
IXGP7N60B		14	7 ③	2	150	0.6	2.3	X005a	
IXGA7N60C		14	7 ③	2.7	45	0.22	2.3	X011b	X010a Weight = 3 g
IXGP7N60C		14	7 ③	2.7	45	0.22	2.3	X005a	
IXGC16N60B2		28	13	2.3	80	0.35	0.83	X010a	X010a Weight = 3 g
IXGA16N60B2		40	16	2.3	80	0.35	0.83	X011b	
IXGP16N60B2		40	16	2.3	80	0.35	0.43	X005a	X011b Weight = 2 g
IXGP30N60B2		45 ①	30	1.8	82	0.9	0.65	X005a	
IXGH30N60B2		70	30	1.8	82	0.9	0.65	X014a	X016a Weight = 6 g
IXGT30N60B2		70	30	1.8	82	0.9	0.42	X019	
IXGR40N60B2		60	33	1.9	82	1.1	0.74	X016a	X011b Weight = 2 g
IXGR50N60B2		68	36	2.2	65	1.55	0.6	X016a	
IXGH40N60B2		75 ①	40	1.7	82	1.1	0.42	X014a	X014a Weight = 6 g
IXGT40N60B2		75 ①	40	1.7	82	1.1	0.42	X019	
IXGR60N60B2		75 ①	47	2	100	2.8	0.5	X016a	X014a Weight = 5 g
IXGH50N60B2		75 ①	50	2	82	1.55	0.31	X014a	
IXGT50N60B2		75 ①	50	2	82	1.55	0.31	X019	X016a Weight = 5 g
IXGH60N60B2		75 ①	60	1.8	100	2.8	0.25	X014a	
IXGT60N60B2		75 ①	60	1.8	100	2.8	0.25	X019	X016a Weight = 5 g
IXGR120N60B		156 ①	102 ③	2.1	160	8.7	0.3	X016a	
IXGK120N60B		200 ①	120 ③	2.1	160	8.7	0.21	X020	X015 Weight = 10 g
IXGX120N60B		200 ①	120 ③	2.1	160	8.7	0.21	X015	
IXGN200N60B		200 ①	120 ③	2.1	160	8.7	0.21	X027a	X015 Weight = 5 g
► IXGH32N90B2	900	64	32	2.7	165	5.25	0.42	X014a	
► IXGT32N90B2		64	32	2.7	165	5.25	0.42	X019	X016a Weight = 5 g
► IXGH50N90B2		75 ①	50	2.7	200	8.7	0.31	X014a	
► IXGT50N90B2		75 ①	50	2.7	200	8.7	0.31	X019	
► IXGA14N120B	1200	28	14	3.3	330	4.85	0.83	X011b	X016a Weight = 5 g
► IXGP14N120B		28	14	3.3	330	4.85	0.83	X005a	
► IXGA15N120B2		30	15 ③	3.5	137	2.8	0.75	X011b	X016a Weight = 5 g
► IXGP15N120B2		30	15 ③	3.5	137	2.8	0.75	X005a	
IXGA15N120B		30	15 ③	3.2	160	3.5	0.83	X011b	X016a Weight = 5 g
IXGP15N120B		30	15 ③	3.2	160	3.5	0.83	X005a	
IXGH15N120B		30	15 ③	3.2	160	3.5	0.65	X014a	X016a Weight = 5 g
IXGT15N120B		30	15 ③	3.2	160	3.5	0.65	X019	
► IXGQ20N120B		40	20	3.4	160	3.5	0.65	X017a	X016a Weight = 5 g
IXGH20N120B		40	20 ③	3.4	160	3.5	0.65	X014a	
IXGT20N120B		40	20 ③	3.4	160	3.5	0.65	X019	X016a Weight = 5 g
IXGR35N120B		70	23 ③	3.3	160	8	0.5	X016a	
IXGH28N120B		50	28 ③	3.5	160	5	0.5	X014a	X019 Weight = 5 g
IXGT28N120B		50	28 ③	3.5	160	5	0.5	X019	
IXGH35N120B		70	35 ③	3.3	160	8	0.42	X014a	X019 Weight = 5 g
IXGT35N120B		70	35 ③	3.3	160	8	0.42	X019	
IXGK35N120B		70	35 ③	3.3	160	8	0.35	X020	X015 Weight = 10 g
IXGX35N120B		70	35 ③	3.3	160	8	0.35	X015	

① Currents may be limited by external package leads.

③ @ T_C=90°C

Polar IGBTs

Mid-Frequency Range (15KHz-40KHz) IGBT/Diode Types

Part Type	V _{CES} max	I _{CP} / I _{CM} max T _J ≤ 150°C tp < 10 μs	I _C max T _C =110°C	V _{CE(sat)} max T _C =25°C	t _{fi} typ T _J =25°C	R _{thJC} max IGBT	Fig. No
► New	V	A	A	V	ns		
► IXGK400N30A3	300	400	200 ①	1.15	250	0.125	X020
► IXGX400N30A3		400	200 ①	1.15	250	0.125	X015
► IXGN400N30A3		400	200 ①	1.15	250	0.125	X027a
► IXGN320N60A3	600	320	120 ①	1.25	300	0.17	X027a

① Currents may be limited by external package leads.

TO-220AB

ISOPLUS220™

TO-263AA

TO-247AD

PLUS247

ISOPLUS247™

TO-268AA



TO-264

SOT-227B miniBLOC

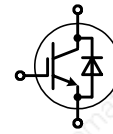
Discrete IGBT G Series

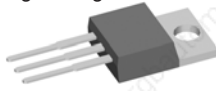
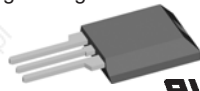
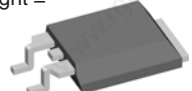
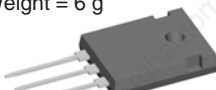
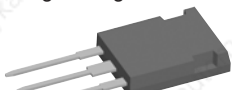
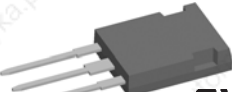

Mid-Frequency Range (15 kHz - 40 kHz) , IGBT with freewheeling diode

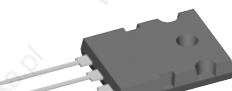

Part Type	V _{CES} max	I _c max T _c =25°C	I _c max T _c =110°C	V _{CE(sat)} max T _c =25°C	t _{fi} typ T _J =25°C	E _{off} typ T _J =125°C	R _{thJC} max IGBT	I _F 110°C	R _{thJC} Diode	Fig. No	Package style
► New	V	A	A	V	ns	mJ	IGBT	A	K/W		Outline drawings on pages 188 - 224
IXGC16N60B2D1	600	28	13	2.3	80	0.35	0.83	10	2.5	X010a	TO-220AB Weight = 4 g  ISOPLUS220™ Weight = 3 g  PLUS220 SMD Weight = 4 g  TO-247AD Weight = 6 g  PLUS247 Weight = 5 g  ISOPLUS247™ Weight = 5 g  TO-268AA Weight = 5 g  TO-264 Weight = 10 g 
IXGA16N60B2D1		40	16	2.3	80	0.35	0.83	11	2.5	X011b	
IXGP16N60B2D1		40	16	2.3	80	0.35	0.83	11	2.5	X005a	
IXGH16N60B2D1		40	16	2.3	80	0.35	0.83	11	2.5	X014a	
IXGH30N60B2D1		70	30	1.8	82	0.9	0.42	30	0.9	X014a	
IXGT30N60B2D1		70	30	1.8	82	0.9	0.42	30	0.9	X019	
IXGR40N60B2D1		60	33	1.9	82	1.1	0.75	25	1.1	X016a	
IXGR50N60B2D1		60	36	2.2	65	1.55	0.6	39	0.85	X016a	
IXGH40N60B2D1		75 ①	40	1.7	82	1.1	0.31	30	0.9	X014a	
IXGT40N60B2D1		75 ①	40	1.7	82	1.1	0.31	30	0.9	X019	
IXGR60N60B2D1		75 ①	47	2	100	2.8	0.5	39	0.85	X016a	
IXGK50N60B2D1		75 ①	50	2	65	1.55	0.25	48	0.65	X020	
IXGX50N60B2D1		75 ①	50	2	65	1.55	0.25	48	0.65	X015	
IXGK60N60B2D1		75 ①	60	1.8	100	2.8	0.25	48	0.65	X020	
IXGX60N60B2D1		75 ①	60	1.8	100	2.8	0.25	48	0.65	X015	
IXGR32N90B2D1	900	47	22	2.9	165	5.25	0.8	22	1.1	X016a	
IXGR50N90B2D1		40	19	2.9	200	8.7	1.25	22	1.1	X016a	
IXGH32N90B2D1		64	32	2.7	165	5.25	0.42	27	0.9	X014a	
IXGT32N90B2D1		64	32	2.7	165	5.25	0.42	27	0.9	X019	
IXGH50N90B2D1		75 ①	50	2.7	200	8.7	0.31	26	0.9	X014a	
IXGT50N90B2D1		75 ①	50	2.7	200	8.7	0.31	26	0.9	X019	
IXGH30N120B3D1	1200	50	30	3.5	160	4.6	0.5	28	0.9	X014a	
IXGT30N120B3D1		50	30	3.5	160	4.6	0.5	28	0.9	X019	
IXGH40N120B2D1		75 ①	40	3.5	140	8.3	0.35	30	0.9	X014a	
IXGT40N120B2D1		75 ①	40	3.5	140	8.3	0.35	30	0.9	X019	

① Currents may be limited by external package leads.

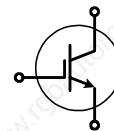
Discrete IGBT G Series for High Speed

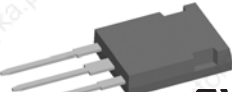

High Frequency Range (> 40 kHz), single IGBT

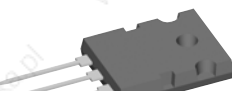
Part Type	V _{CES} max	I _c max T _c =25°C	I _c max T _c =110°C	V _{CE(sat)} max T _c =25°C	t _{fi} typ T _J =25°C	E _{off} typ T _J =125°C	R _{thJC} max IGBT	Fig. No	Package style
► New	V	A	A	V	ns	mJ	IGBT		
IXGC16N60C2	600	20	8	3	35	0.15	2.00	X010a	ISOPLUS247™ Weight = 5 g  TO-268AA Weight = 5 g  TO-264 Weight = 10 g 
IXGA16N60C2		40	16	3	35	0.15	0.83	X011b	
IXGP16N60C2		40	16	3	35	0.15	0.83	X005a	
IXGR40N60C2		56	26	2.7	32	0.5	0.74	X016a	
IXGH30N60C2		70	30	2.5	32	0.4	0.65	X014a	
IXGP30N60C2		70	30	2.5	32	0.4	0.65	X005a	
IXGT30N60C2		70	30	2.5	32	0.4	0.65	X019	
IXGH40N60C2		75 ①	40	2.5	32	0.5	0.42	X014a	
IXGR50N60C2		75 ①	40	2.7	48	0.74	0.62	X016a	
IXGT40N60C2		75 ①	40	2.5	32	0.5	0.42	X019	
IXGR60N60C2		75 ①	48	2.7	35	0.5	0.32	X016a	
IXGH50N60C2		75 ①	50	2.5	48	0.74	0.31	X014a	
IXGT50N60C2		75 ①	50	2.5	48	0.74	0.31	X019	
IXGR120N60C2		75 ①	60	2.7	45	1.5	0.42	X016a	
IXGH60N60C2		75 ①	60	2.5	35	1.2	0.26	X014a	
IXGT60N60C2		75 ①	60	2.5	35	1.2	0.26	X019	
IXGN60N60C2		75 ①	60	2.5	35	1.2	0.26	X027a	
IXGK120N60C2		75 ①	75 ③	2.5	45	1.5	0.15	X020	
IXGX120N60C2		75 ①	75 ③	2.5	45	1.5	0.15	X015	

① Currents may be limited by external package leads.

③ @ T_c=90°C

Discrete IGBT G Series for High Speed

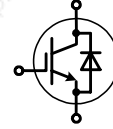

High Frequency Range (> 40 kHz), IGBT with freewheeling diode

Part Type	V _{CES} max	I _c max	I _c max	V _{CE(sat)} max	t _{fi} typ	E _{off} typ	R _{thJC} max	I _F 110°C	R _{thJC}	I _F 90°C	R _{thJC}	Package style
▶ New	V	T _c =25°C A	T _c =110°C A	T _c =25°C V	T _J =25°C ns	T _J =125°C mJ	IGBT	A	Diode K/W	Fig. No	Outline drawings on pages 188 - 224	
▶ IXGC16N60C2D1	600	20	8	3	35	0.15	2	42	2.5	X010a	X005a TO-220AB	
▶ IXGA16N60C2D1		40	16	3	35	0.15	0.83	12	2.5	X011b	Weight = 4 g	
▶ IXGP16N60C2D1		40	16	3	35	0.15	0.83	16	2.5	X005b		
▶ IXGH16N60C2D1		40	16	3	35	0.15	0.83	11	2.5	X010a		
▶ IXGR40N60C2D1		56	26	2.7	32	0.2	0.74	50	1.5	X016a		
▶ IXGH30N60C2D1		70	30	2.5	32	0.4	0.65	30	0.9	X014a		
▶ IXGT30N60C2D1		70	30	2.5	32	0.4	0.65	30	0.9	X019		
▶ IXGH40N60C2D1		75	40	2.5	32	0.2	0.42	40	0.9	X014a	X010a ISOPLUS220™	
▶ IXGJ40N60C2D1		75 ①	40	2.5	32	0.2	0.42	40	0.9	X018	Weight = 3 g	
▶ IXGR50N60C2D1		75 ①	40	2.7	48	0.74	0.75	42	0.85	X016a		
▶ IXGT40N60C2D1		75 ①	40	2.5	32	0.2	0.42	40	0.9	X019		
▶ IXGR60N60C2D1		75 ①	48	2.7	35	1.2	0.65	60	0.85	X016a		
▶ IXGK50N60C2D1		75	50	2.5	48	0.74	0.31	50	0.85	X020		
▶ IXGX50N60C2D1		75 ①	50	2.5	48	0.74	0.31	50	0.85	X015		
▶ IXGK60N60C2D1		75	60	2.5	35	1.2	0.26	60	0.85	X020	X011b TO-263AA	
▶ IXGN60N60C2D1		75	60	2.5	35	1.2	0.26	39	0.85	X027a	Weight = 2 g	
▶ IXGT60N60C2D1		75 ①	60	2.5	35	1.2	0.26	60	0.85	X019		
▶ IXGX60N60C2D1		75 ①	60	2.5	35	1.2	0.26	60	0.85	X015		

1700 V IGBT

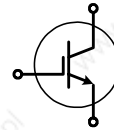

Low saturation voltage Types

Part Type	V _{CES} max	I _c max	I _c max	V _{CE(sat)} max	E _{off} typ	R _{thJC} max	Fig. No
▶ New	V	T _c =25°C A	T _c =110°C A	T _c =25°C V	T _J =125°C mJ	IGBT	
IXGH25N160	1600	75	35	2.5	20	0.42	X014a
IXGT25N160		75	35	2.5	20	0.42	X019
IXGH6N170	1700	12	6	4	2	1.65	X014a
IXGT6N170		12	6	4	2	1.65	X019
IXGH10N170		20	10	4	4.7	1.1	X014a
IXGT10N170		20	10	4	4.7	1.1	X019
IXGH16N170		32	16	3.5	8	0.65	X014a
IXGT16N170		32	16	3.5	8	0.65	X019
▶ IXGF32N170		26	12	3.5	13.5	0.65	X024c
IXGH24N170		50	24	3.3	12	0.5	X014a
IXGT24N170		50	24	3.3	12	0.5	X019
IXGH32N170		75 ①	32	3.3	14	0.35	X014a
IXGT32N170		75 ①	32	3.3	14	0.35	X019

Low Saturation Voltage IGBT with SONIC-FRD Fast Recovery Diodes

Part Type	V _{CES} max	I _c max	I _c max	V _{CE(sat)} max	t _{fi} typ	E _{off} typ	R _{thJC} max	I _F 90°C	R _{thJC}	Fig. No
▶ New	V	T _c =25°C A	T _c =90°C A	T _c =25°C V	T _J =25°C ns	T _J =125°C mJ	IGBT	A	Diode K/W	
▶ IXGR32N170H1	1700	38	20	3.5	250	13.6	0.65	14	1.5	X016a
IXGX32N170H1		75 ①	32	3.3	250	22	0.35	60	0.3	X015

① Currents may be limited by external package leads.

1700 V IGBT

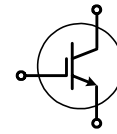

High speed Types

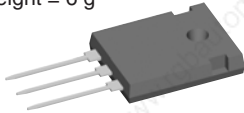
Part Type	V _{CES} max V	I _c max T _c =25°C A	I _c max T _c =110°C A	V _{CE(sat)} max T _c =25°C V	E _{off} typ T _J =125°C mJ	R _{thJC} max IGBT	Fig. No	Package style
► New								Outline drawings on pages 188 - 224
IXGH6N170A	1700	6	3	7	0.26	1.65	X014a	TO-247AD X014a Weight = 6 g 
IXGT6N170A		6	3	7	0.26	1.65	X019	
IXGH10N170A		10	5	6	0.6	1.1	X014a	
IXGT10N170A		10	5	6	0.6	1.1	X019	
IXGH16N170A		16	8	5	1.1	0.65	X014a	
IXGT16N170A		16	8	5	1.1	0.65	X019	
IXGH24N170A		24	16	6	1.7	0.5	X014a	
IXGT24N170A		24	16	6	1.7	0.5	X019	
IXGH32N170A		32	21	5	3	0.35	X014a	
IXGT32N170A		32	21	5	3	0.35	X019	

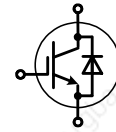

High Speed IGBT with SONIC-FRD Fast Recovery Diodes

Part Type	V _{CES} max V	I _c max T _c =25°C A	I _c max T _c =90°C A	V _{CE(sat)} max T _c =25°C V	t _{fi} typ T _J =25°C ns	E _{off} typ T _J =125°C mJ	R _{thJC} max IGBT	I _F 90°C A	R _{thJC} Diode K/W	Fig. No
► New										
IXGR16N170AH1	1700	16	8	5	40	1.1	1.04	14	1.5	X016a
IXGH16N170AH1		16	8	5	40	1.1	0.65	20	0.9	X014a
IXGT16N170AH1		16	8	5	40	1.1	0.65	20	0.9	X019
IXGH24N170AH1		24	16	6	45	1.7	0.5	17	0.9	X014a
IXGT24N170AH1		24	16	6	45	1.7	0.5	17	0.9	X019
IXGR32N170AH1		26	17	5.2	50	2.4	0.65	14	1.5	X016a
IXGX32N170AH1		32	21	5	50	3	0.35	60	0.3	X015

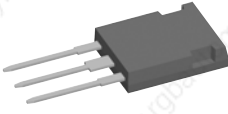
X015 **PLUS247**
Weight = 5 g

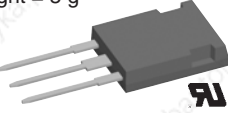
X016a **ISOPLUS247™**
Weight = 5 g

X019 **TO-268AA**
Weight = 5 g

Very High Voltage IGBTs

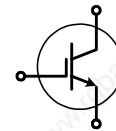

Part Type	V _{CES} max V	I _c max T _c =25°C A	I _c max T _c =90°C A	V _{CE(sat)} max T _c =25°C V	t _{fi} typ T _J =25°C ns	E _{off} typ T _J =125°C mJ	R _{thJC} max IGBT	Fig. No
► New								
IXLF19N250A	2500	32	19	3.9	250	30	0.5	X024c
IXEL40N400	4000	62	40	4	450	220	0.33	X022c

X022s **ISOPLUS264™**
Weight = 10 g

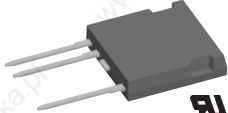
X024c **ISOPLUS i4-PAC™**
Weight = 6 g

BiMOSFET™

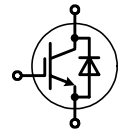

High Speed Types in 1600 V

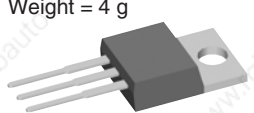
Type	V _{CES} V	I _{C25} T _C =25°C A	I _{C90} T _C =90°C A	V _{CE(sat)} typ T _C =25°C V	Gate drive V	t _f typ T _C =125°C ns	R _{thJC} K/W	Fig. No.	Package style Outline drawings on page 188 - 224
IXBP5N160G	1600	5.7	3.5	4.9	10	70	1.75	X005a	 X005a TO-220AB Weight = 4 g
IXBH5N160G		5.7	3.5	4.9	10	70	1.75	X014a	
IXBF9N160G		7	5	4.9	10	70	1.75	X024c	
IXBH9N160G		9	5	4.9	10	70	1.25	X014a	
IXBF40N160		28	16	6.2	15	40	0.50	X024c	
IXBH40N160		33	20	6.2	15	40	0.35	X014a	

1700 V Types

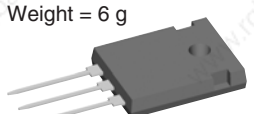
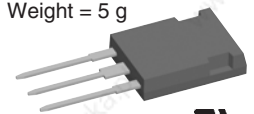
High speed									
IXBH16N170A	1700	16	10	4.7	15	50	0.83	X014a	 X014a TO-247AD Weight = 6 g
IXBT16N170A		16	10	4.7	15	50	0.83	X019	
IXBT42N170A		42	25	5.0	15	50	0.35	X019	
Low V _{CE(sat)}									
IXBH6N170	1700	10	6	2.3	15	1200	1.8	X014a	 X016a ISOPLUS247™ Weight = 5 g
IXBT6N170		10	6	2.3	15	1200	1.8	X019	
IXBH10N170		16	10	2.3	15	1200	1.25	X014a	
IXBT10N170		16	10	2.3	15	1200	1.25	X019	
IXBH16N170		25	16	2.3	15	1200	0.83	X014a	
IXBT16N170		25	16	2.3	15	1200	0.83	X019	
IXBH42N170		70	42	2.3	15	1200	0.35	X014a	
IXBT 42N170		70	42	2.3	15	1200	0.35	X019	

BiMOSFET™ includes a body diode, which can carry rated current
 High voltage, high speed, pulse current applications

RIGBT

IGBT with Reverse Blocking Capability

- Applications: lighting control, AC motor control, matrix converters
- No extra on state losses for reverse blocking feature

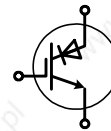

Type	Configuration	V _{CES} max V	I _{C25} T _C =25°C A	I _{C90} T _C =90°C A	V _{CE(sat)} typ T _C =25°C V	t _{rr} typ T _C =125°C μs	t _f typ T _C =125°C ns	Fig. No.
► New								
► IXRP15N120	single RIGBT	1200	25	15	2.5	0.3	46	X005a
► IXRH40N120	single RIGBT	1200	55	35	2.2	1.6	46	X014a
► IXRR40N120	single RIGBT	1200	45	28	2.2	1.6	46	X016a

X019 **TO-268**
 Weight = 5 g



preliminary data, typical values

X024c **ISOPLUS i4-PAC™**
 Weight = 6 g

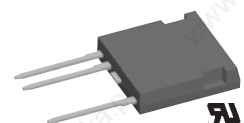

Power MOSFETs and MOSFET Modules

PolarHT™ and PolarHV™ MOSFETs for very low $R_{DS(on)}$

PolarHT™ and PolarHV™ MOSFETs feature a proprietary cell design and processing that has resulted in a MOSFET with a 30% reduction in $R_{DS(on)}$ per unit area along with a decrease in gate charge. IXYS has also reduced the wafer thickness, which substantially reduces thermal resistance. The combination of lower $R_{DS(on)}$, lower gate charge and higher power dissipation capability has resulted in a new family of MOSFETs, which will increase the cost effectiveness in SMPS applications.

PolarHT™ and PolarHV™ HiPerFETs with very low $R_{DS(on)}$, very low R_{thJC} and fast Body Diode

IXYS's PolarHT™ and PolarHV™ HiPerFETs combine the strengths of PolarHT family with a faster body diode, whose t_{rr} is reduced to make them suitable for phase-shift bridges, motor control and Uninterruptible Power Supply applications (UPS). So here is a win-win situation with lowest $R_{DS(on)}$, low R_{thJC} , very low Q_g and a faster body diode.

HiPerFET™ Power MOSFETs

The High Performance MOSFET family of Power MOSFETs is designed to provide superior dv/dt performance while eliminating the need for discrete, fast recovery "free wheeling diodes" in a broad range of power switching applications.

This class of Power MOSFET uses IXYS' HDMOS process, which improves the ruggedness of the MOSFET while reducing the reverse recovery time of the fast intrinsic diode to 250 ns or less at elevated (150°C) junction temperature even for high V_{DSS} rated parts. The performance of the fast intrinsic diode is comparable to discrete high voltage diodes and is tailored to minimize power dissipation and stress in the MOSFET.

'Q2 - Class' HiPerFET™ MOSFETs for lower gate charge and faster switching

New 'Q2 - class' HiPerFET MOSFETs (identified by the suffix letter Q2) are the result of a revolutionary new chip design, which decreases the MOSFET's total gate charge Q_g and the Miller capacitance C_{rss} , while maintaining the ruggedness and fast switching intrinsic diode of the company's current HiPerFET product line. The result is a MOSFET with dramatically improved switching efficiencies and thus enabling higher frequency operation and smaller power supplies.

The 'Q2-Class' line combines the low gate charge advantages with a double-metal construction resulting in a new generation of MOSFETs with an intrinsic gate resistance an order of magnitude lower than conventional MOSFETs. The resulting reduction in switching losses allows large MOSFETs to operate satisfactorily up to the multi-megahertz region.

Standard and MegaMOS™FETs

The IXYS family of high voltage N-Channel Power MOSFETs are designed to provide superior performance and ruggedness in high voltage switching applications. Major improvements are continuing to be made using high-cell density designs processed on thin silicon wafers for lower thermal resistance. The MegaMOS™FET family of large scale monolithic Power MOSFETs provides significantly higher power handling capability than industry standard MOSFETs.

Depletion Mode MOSFETs

Depletion mode MOSFETs, unlike the regular enhancement type MOSFETs, requires a negative gate bias to turn off. Consequently they remain on at or above zero gate bias voltage but otherwise have similar MOSFET characteristics. Their $R_{DS(on)}$ and breakdown voltage have a positive temperature coefficient, increasing the gate bias voltage increases the gate channel conductivity and so decreases $R_{DS(on)}$ to some extent and there is a usable intrinsic diode.

There are many applications in which Depletion Mode MOSFETs can be used: current regulators, off-line linear regulators, input transient voltage suppressors, input current inrush limiters, solid state relays etc.

P-Channel MOSFETs

For applications requiring load to be connected to ground/common, it is very convenient to use P-Channel MOSFETs. IXYS has a wide range of high current, high Voltage P-Channel MOSFETs which find variety of applications in complementary output stage of Totem Pole output stages, Buck Converters and those configurations, in which load must be connected between Source of MOSFET and ground/common terminals.

Linear Power MOSFETs

In some applications, customers need square SOA characteristics, while operating MOSFETs with simultaneous presence of V_{DS} and I_D . IXYS Linear

MOSFETs are very rugged to make this possible. Typical applications for these MOSFETs are constant current regulators and electronic loads.

CoolMOS™ Power MOSFETs

The specific resistance of a conventional designed MOSFET increases by more than the square of its blocking voltage. For CoolMOS™ FETs, this relation can be reduced to a linear function making it possible to achieve extremely low on-resistances at high breakdown voltages and small chip sizes. IXYS offers CoolMOS™ performance in the industry standard SOT-227 package as well as the isolated packages: **ISOPLUS247™**, **ISOPLUS220™** and **ISOPLUS i4-PAC™**. These isolated packages are also available in many MOSFET types affording greater convenience and safety.

Due to their internal DCB isolation, these devices simplify assembly and provide lower thermal resistance from junction to heatsink compared to external isolation materials. Together with the low $R_{DS(on)}$, the junction temperature could be significantly reduced, improving efficiency and reliability. At the same case temperature, the die can control higher currents, saving space and costs by utilizing a smaller number of components. CoolMOS™ devices are avalanche rated, guaranteeing rugged operation.

Trench Gate Power MOSFETs

IXYS Trench Power MOSFETs are ideally suited for low voltage/ high current applications. These MOSFETs feature an exceedingly low $R_{DS(on)}$, thus guaranteeing very low power dissipation in low voltage, high current power switching applications.

This, combined with wide ranging operating junction temperature from -40°C to 175 °C make them suitable candidates for automobile applications and other similar demanding applications in harsh environments.

IXYS has currently a wide portfolio of Trench Gate MOSFETs with ratings from 55V to 300V and 42A to 220A. By optimization of several parameters, IXYS Corporation has come out with special higher Voltage rated Trench Gate MOSFETs for critical applications. Likewise, special Trench Gate MOSFET modules find variety of applications in very demanding Automotive segments.

PolarHT™ N-Channel Power MOSFETs



Low Voltage Types

Part Type	V _{DSS} max	I _D (cont) max	R _{DS(on)} max	C _{iss} typ	Q _g typ	t _{rr} max	R _{thJC} max	P _D	Fig. No	Package style
► New	V	T _C =25°C A	T _C =25°C Ω	pF	nC	ns	K/W	W	Fig.	Outline drawings on pages 188 - 224
► IXTP110N055P	55	110*	0.0135	2210	76	80	0.38	330	X005a	X005a Weight = 4 g
► IXTA110N055P		110*	0.0135	2210	76	80	0.38	330	X011b	
► IXTQ110N055P		110*	0.0135	2210	76	80	0.38	330	X017a	
► IXTQ150N06P	60	150*	0.01	3000	118	120	0.31	480	X017a	X007a Weight = 5 g
► IXTQ200N06P		200*	0.006	5400	200	80	0.21	714	X017a	
► IXTP75N10P	100	75	0.025	2250	74	120	0.42	360	X005a	X007a Weight = 5 g
► IXTA75N10P		75	0.025	2250	74	120	0.42	360	X011b	
► IXTQ75N10P		75	0.025	2250	74	120	0.42	360	X017a	
IXTQ110N10P		110*	0.015	3550	110	130	0.31	480	X017a	
IXTT110N10P		110*	0.015	3550	110	130	0.31	480	X019	
IXTQ140N10P		140*	0.011	4700	155	120	0.25	600	X017a	
IXTT140N10P		140*	0.011	4700	155	120	0.25	600	X019	
► IXTQ170N10P		170*	0.009	6000	198	120	0.21	714	X017a	
► IXTT170N10P		170*	0.009	6000	198	120	0.21	714	X019	
► IXTK170N10P		170*	0.009	6000	198	120	0.21	714	X020	
► IXTK200N10P		200*	0.0075	7600	240	100	0.18	800	X020	X011b Weight = 2 g
► IXTR200N10P		120*	0.008	7600	240	100	0.5	300	X016a	
► IXTP62N15P	150	62	0.04	2250	70	150	0.42	350	X005a	X014a Weight = 6 g
► IXTA62N15P		62	0.04	2250	70	150	0.42	350	X011b	
► IXTQ62N15P		62	0.04	2250	70	150	0.42	350	X017a	
IXTQ96N15P		96*	0.024	3500	110	150	0.31	480	X017a	
IXTT96N15P		96*	0.024	3500	110	150	0.31	480	X019	
► IXTQ120N15P		120*	0.016	4900	150	150	0.25	600	X017a	
► IXTT120N15P		120*	0.016	4900	150	150	0.25	600	X019	
► IXTQ150N15P		150*	0.013	5800	190	150	0.21	714	X017a	
► IXTK150N15P		150*	0.013	5800	190	150	0.21	714	X020	
► IXTK180N15P		180*	0.01	7000	240	150	0.18	800	X020	
► IXTP50N20P	200	50	0.06	2250	70	150	0.42	360	X005a	X016a Weight = 5 g
► IXTP50N20PM		20	0.066	2250	70	150	1.66	90	X007a	
► IXTA50N20P		50	0.06	2250	70	150	0.42	360	X011b	
► IXTQ50N20P		50	0.06	2250	70	150	0.42	360	X017a	
IXTQ74N20P		74	0.034	3300	107	160	0.31	480	X017a	
IXTT74N20P		74	0.034	3300	107	160	0.31	480	X019	
IXTQ96N20P		96*	0.024	4800	145	160	0.25	600	X017a	
IXTH96N20P		96*	0.024	4800	145	160	0.25	600	X014a	
IXTT96N20P		96*	0.024	4800	145	160	0.25	600	X019	
► IXTQ120N20P		120*	0.022	6000	152	180	0.21	714	X017a	
► IXTK120N20P		120*	0.022	6000	152	180	0.21	714	X020	
► IXTK140N20P		140*	0.018	7500	240	180	0.18	800	X020	
► IXTP42N25P	250	42	0.084	2300	70	200	0.42	300	X005a	X017a Weight = 5 g
► IXTA42N25P		42	0.084	2300	70	200	0.42	300	X011b	
► IXTQ42N25P		42	0.084	2300	70	200	0.42	300	X017a	
IXTQ64N25P		64	0.049	3450	105	200	0.31	400	X017a	
IXTT64N25P		64	0.049	3450	105	200	0.31	400	X019	
IXTQ82N25P		82	0.035	4800	142	200	0.25	500	X017a	
IXTT82N25P		82*	0.035	4800	142	200	0.25	500	X019	
IXTK82N25P		82*	0.035	4800	142	200	0.25	500	X020	
IXTQ100N25P		100*	0.027	6300	185	200	0.21	600	X017a	
IXTK100N25P		100	0.027	6300	185	200	0.21	600	X020	
IXTT100N25P		100*	0.027	6300	185	200	0.21	600	X019	X019 Weight = 5 g
► IXTK120N25P		120*	0.024	8000	185	200	0.18	700	X020	
► IXTP36N30P	300	36	0.11	2250	70	250	0.42	300	X005a	X020 Weight = 10 g
► IXTA36N30P		36	0.11	2250	70	250	0.42	300	X011b	
► IXTQ36N30P		36	0.11	2250	70	250	0.42	300	X017a	
IXTQ52N30P		52	0.066	3490	110	250	0.31	400	X017a	
IXTT52N30P		52	0.066	3490	110	250	0.31	400	X019	
IXTQ69N30P		69	0.049	4960	156	250	0.25	500	X017a	
IXTT69N30P		69	0.049	4960	156	250	0.25	500	X019	
IXTQ88N30P		88*	0.04	6300	180	250	0.21	600	X017a	
IXTH88N30P		88*	0.04	6300	180	250	0.21	600	X014a	
IXTK88N30P		88	0.04	6300	180	250	0.21	600	X020	
IXTT88N30P		88*	0.04	6300	180	250	0.21	600	X019	
IXTK102N30P		102*	0.033	7500	224	250	0.18	700	X020	

Note * - Drain and source currents may be limited by external package leads. Note: Performance and availability are subject to change at IXYS' discretion.

PolarHV™ Power MOSFETs

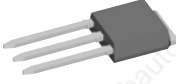
High Voltage Types

Part Type	V _{DSS} max	I _D (cont) max T _C =25°C	R _{DS(on)} max T _C =25°C	C _{iss} typ	Q _g typ	t _{rr} max	R _{thJC} max	P _D	Fig. No	Package style	
► New	V	A	Ω	pF	nC	ns	K/W	W	Fig. No	Outline drawings on pages 188 - 224	
► IXTY1R6N50P	500	1.6	6	120	2	400	3.00	42.0	X004	X003 Weight = 0.3 g	
► IXTP1R6N50P		1.6	6	120	2	400	3.00	42.0	X005a		
► IXTY2R4N50P		2.4	3.5	225	7.25	400	2.5	50	X004		
► IXTP2R4N50P		2.4	3.5	225	7.25	400	2.5	50	X005a		
► IXTY3N50P		3.6	2	409	9.3	400	1.80	70	X004		
► IXTP3N50P		3.6	2	409	9.3	400	1.80	70	X005a		
► IXTA3N50P		3.6	2	409	9.3	400	1.80	70	X011b		
► IXTY5N50P		5	1.3	600	12	400	1.5	83.3	X004		
► IXTP5N50P		5	1.3	600	12	400	1.5	83.3	X005a		
► IXTA5N50P		5	1.3	600	12	400	1.5	83.3	X011b		
► IXTP6N50P		6	1	750	15	400	1.2	105	X005a		
► IXTA6N50P		6	1	750	15	400	1.2	105	X011b		
► IXTA8N50P		8	0.8	1200	21	400	1.00	150	X011b		
► IXTP8N50P		8	0.8	1200	21	400	1.00	150	X005a		
► IXTP8N50PM		4	0.88	1200	21	400	3	41	X007a		
► IXTI12N50P		12	0.5	1689	30	400	0.62	200	X008		
► IXTP12N50P		12	0.5	1689	30	400	0.62	200	X005a		
► IXTP12N50PM		6	0.55	1800	30	400	2.5	50	X007a		
► IXTP16N50P		16	0.4	2110	40	400	0.42	300	X005a		
► IXTA16N50P		16	0.4	2110	40	400	0.42	300	X011b		
► IXTQ16N50P	16	0.4	2110	40	400	0.42	300	X017a			
► IXTV22N50P	22	0.27	2629	50	400	0.35	350	X009			
► IXTV22N50PS	22	0.27	2629	50	400	0.35	350	X013			
► IXTQ22N50P	22	0.27	2629	50	400	0.35	350	X017a			
► IXTH22N50P	22	0.27	2630	50	400	0.35	350	X014a			
► IXTV26N50P	26	0.23	3600	65	300	0.31	400	X009			
► IXTV26N50PS	26	0.23	3600	66	300	0.31	400	X013			
► IXTQ26N50P	26	0.23	3600	67	300	0.31	400	X017a			
► IXTT26N50P	26	0.23	3600	68	300	0.31	400	X019			
► IXTC26N50P	14	0.26	3600	96	400	0.95	130	X010a			
► IXTV30N50P	30	0.2	4150	72	400	0.27	460	X009			
► IXTV30N50PS	30	0.2	4150	72	400	0.27	460	X013			
► IXTH30N50P	30	0.2	4150	72	400	0.27	460	X014a			
► IXTQ30N50P	30	0.2	4150	72	400	0.27	460	X017a			
► IXTT30N50P	30	0.2	4150	72	400	0.27	460	X019			
► IXTV36N50P	36	0.17	4770	82	400	0.23	540	X009			
► IXTV36N50PS	36	0.17	4770	82	400	0.23	540	X013			
► IXTH36N50P	36	0.17	4770	82	400	0.23	540	X014a			
► IXTQ36N50P	36	0.17	4770	82	400	0.23	540	X017a			
► IXTT36N50P	36	0.17	4770	82	400	0.23	540	X019			
► IXTQ44N50P	44	0.14	5440	98	400	0.19	650	X017a			
► IXTU1R4N60P	600	1.4	9.0	140	5.2	500	2.5	50	X003	X013 Weight = 2 g	
► IXTP1R4N60P		1.4	9.0	140	5.2	500	2.5	50	X005a		
► IXTY1R4N60P		1.4	9.0	140	5.2	500	2.5	50	X004		
► IXTP2N60P		2	4.7	205	4	500	2.50	50	X005a		
► IXTY2N60P		2	4.7	205	4	500	2.50	50	X004		
► IXTY3N60P		3	2.8	370	8	500	1.80	70	X004		
► IXTP3N60P		3	2.8	370	8	500	1.80	70	X005a		
► IXTA3N60P		3	2.8	370	8	500	1.80	70	X011b		
► IXTP4N60P		4	1.9	560	12	500	1.50	83.0	X005a		
► IXTA4N60P		4	1.9	560	12	500	1.50	83.0	X011b		
► IXTP5N60P		5	1.6	690	14	500	1.25	100	X005a		
► IXTA5N60P		5	1.6	690	14	500	1.25	100	X011b		
► IXTA7N60P		7	1	1000	20	500	1.00	125	X011b		
► IXTP7N60P		7	1	1000	20	500	1.00	125	X005a		
► IXTA10N60P		10	0.74	1500	30	500	0.62	166	X011b		
► IXTI10N60P		10	0.74	1500	30	500	0.62	166	X008		
► IXTP10N60P		10	0.74	1500	30	500	0.62	166	X005a		
► IXTP10N60PM		5	0.81	1500	30	500	2.5	50	X007a		
► IXTP14N60P		14	0.55	2200	40	500	0.42	300	X005a		
► IXTA14N60P		14	0.55	2200	40	500	0.42	300	X011b		
► IXTQ14N60P	14	0.55	2200	40	500	0.42	300	X017a			
► IXTV18N60P	18	0.42	3000	50	500	0.35	360	X009			

Note: Performance and availability are subject to change at IXYS' discretion.

PolarHV™ Power MOSFETs

High Voltage Types

Part Type	V _{DSS} max	I _D (cont) max T _C =25°C	R _{DS(on)} max T _C =25°C	C _{iss} typ	Q _g typ	t _{rr} max	R _{thJC} max	P _D	No	Package style
> New	V	A	Ω	pF	nC	ns	K/W	W	Fig.	Outline drawings on pages 188 - 224
> IXTV18N60PS	600	18	0.42	3000	50	500	0.35	360	X013	X004 Weight = 0.3 g
> IXTV18N60P		18	0.42	3000	50	500	0.35	360	X017a	
> IXTV22N60P		22	0.35	3600	62	500	0.31	400	X009	
> IXTV22N60PS		22	0.35	3600	62	500	0.31	400	X013	
> IXTV22N60P		22	0.35	3600	62	500	0.31	400	X017a	
> IXTV26N60P		26	0.27	4100	126	500	0.27	460	X009	
> IXTV26N60PS		26	0.27	4100	126	500	0.27	460	X013	
> IXTH26N60P		26	0.27	4100	126	500	0.27	460	X014a	
> IXTV26N60P		26	0.27	4100	126	500	0.27	460	X017a	
> IXTT26N60P		26	0.27	4100	126	500	0.27	460	X019	
> IXTV30N60P		30	0.24	5050	82	500	0.23	540	X009	
> IXTV30N60PS		30	0.24	5050	82	500	0.23	540	X013	
> IXTH30N60P		30	0.24	5050	82	500	0.23	540	X014a	
> IXTV30N60P		30	0.24	5050	82	500	0.23	540	X017a	
> IXTT30N60P	30	0.24	5050	82	500	0.23	540	X019		
> IXTA2N80P	800	2	6	370	8	650	1.8	70	X011b	X009 Weight = 4 g
> IXTP2N80P		2	6	370	8	650	1.8	70	X005a	
> IXTY2N80P		2	6	370	8	650	1.8	70	X004	
> IXTA4N80P		3.5	3	690	15	650	1.25	100	X011b	
> IXTP4N80P		3.5	3	690	15	650	1.25	100	X005a	
> IXTP4N80P		3.5	3	690	15	650	1.25	100	X005a	

Note: Performance and availability are subject to change at IXYS' discretion.

PolarHT™ HiPerFET with Fast Intrinsic Diode

Low Voltage Types

Part Type	V _{DSS} max	I _D (cont) max T _C =25°C	R _{DS(on)} max T _C =25°C	C _{iss} typ	Q _g typ	t _{rr} max	R _{thJC} max	P _D	No	Package style		
> New	V	A	Ω	pF	nC	ns	K/W	W	Fig.	Outline drawings on pages 188 - 224		
> IXFH110N10P	100	110*	0.015	3550	110	200	0.31	480	X014a	X010a Weight = 6 g		
> IXFV110N10P		110*	0.015	3550	110	200	0.31	480	X009			
> IXFV110N10PS		110*	0.015	3550	110	200	0.31	480	X013			
> IXFC110N10P		66*	0.017	3550	110	200	0.95	160	X010a			
> IXFH140N10P		140*	0.011	4700	155	200	0.25	600	X014a			
> IXFT140N10P		140*	0.011	4700	155	200	0.25	600	X019			
> IXFH170N10P		170*	0.009	6000	198	200	0.21	714	X014a			
> IXFK170N10P		170*	0.009	6000	198	200	0.21	714	X020			
> IXFK200N10P		200*	0.0075	7600	240	140	0.18	833	X020			
> IXFX200N10P		200*	0.0075	7600	240	140	0.18	833	X015			
> IXFR200N10P		133*	0.008	7600	240	140	0.42	350	X016a			
> IXFN200N10P		200*	0.0075	7600	240	140	0.18	833	X027a			
> IXFH96N15P		150	96*	0.024	3500	110	200	0.31	480		X014a	X017a Weight = 5 g
> IXFV96N15P			96*	0.024	3500	110	200	0.31	480		X009	
> IXFV96N15PS	96*		0.024	3500	110	200	0.31	480	X013			
> IXFC96N15P	58		0.026	3500	110	200	1.25	120	X010a			
> IXFH120N15P	120*		0.016	4900	150	200	0.25	600	X014a			
> IXFT120N15P	120*		0.016	4900	150	200	0.25	600	X019			
> IXFH150N15P	150*		0.013	5800	190	200	0.21	714	X014a			
> IXFK150N15P	150*		0.013	5800	190	200	0.21	714	X020			
> IXFK180N15P	180*		0.011	7000	240	200	0.18	833	X020			
> IXFR180N15P	94*		0.013	7000	240	200	0.5	250	X016a			
> IXFN180N15P	180*		0.011	7000	240	200	0.18	833	X027a			
> IXFX180N15P	180*		0.011	7000	240	200	0.18	833	X015			
> IXFH74N20P	200		74	0.034	3300	107	200	0.31	480	X014a	X020 Weight = 10 g	
> IXFV74N20P			74*	0.034	3300	107	200	0.31	480	X009		
> IXFV74N20PS		74*	0.034	3300	107	200	0.31	480	X013			
> IXFC74N20P		35	0.036	3300	107	200	1.25	100	X010a			
> IXFH96N20P		96*	0.024	4800	145	200	0.25	600	X014a			
> IXFT96N20P		96*	0.024	4800	145	200	0.25	600	X019			
> IXFV96N20P		96*	0.024	4800	145	200	0.25	600	X009			
> IXFV96N20P		96*	0.024	4800	145	200	0.25	600	X009			

Note 1 - performance and availability are subject to change at the discretion of IXYS

Note 2. * - Drain and source currents may be limited by external package leads.

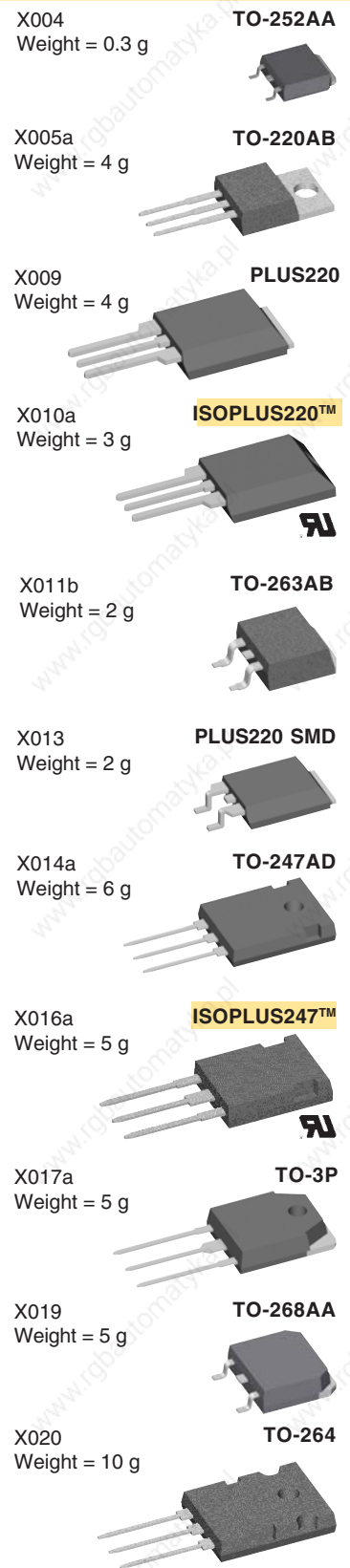

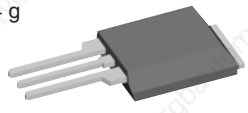
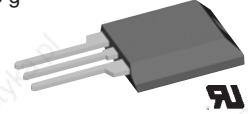
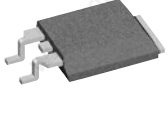
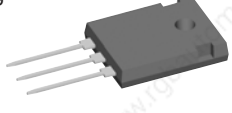
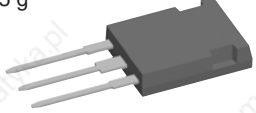

PolarHT™ HiPerFET with Fast Intrinsic Diode

Low Voltage Types

Part Type	V _{DSS} max	I _D (cont) max T _C =25°C	R _{DS(on)} max T _C =25°C	C _{iss} typ	Q _g typ	t _{rr} max	R _{thJC} max	P _D	Fig. No	Package style	
► New	V	A	Ω	pF	nC	ns	K/W	W	Fig. No	Outline drawings on pages 188 - 224	
► IXFH120N20P	200	120*	0.022	6000	185	150	0.21	714	X014a	X009 Weight = 4 g	PLUS220 
► IXFK120N20P		120*	0.022	6000	185	150	0.21	714	X020		
► IXFK140N20P		140*	0.018	7500	240	150	0.18	833	X020		
► IXFR140N20P		90*	0.022	7500	240	150	0.5	300	X016a		
► IXFN140N20P		140*	0.018	7500	240	150	0.18	833	X027a		
► IXFH100N25P	250	100*	0.027	6300	185	200	0.21	600	X014a	X010a Weight = 3 g	ISOPLUS220™ 
► IXFX120N25P		120*	0.024	8000	185	200	0.18	833	X015		
► IXFK120N25P		120*	0.024	8000	185	200	0.18	833	X020		
► IXFH52N30P	300	52	0.066	3490	110	200	0.31	400	X014a	X013 Weight = 4 g	PLUS220 SMD 
► IXFV52N30P		52	0.066	3490	110	200	0.31	400	X009		
► IXFV52N30PS		52	0.066	3490	110	200	0.31	400	X013		
► IXFC52N30P		31	0.072	3490	110	200	1.25	100	X010a		
► IXFH69N30P		69	0.049	4960	156	200	0.25	500	X014a		
► IXFT69N30P		69	0.049	4960	156	200	0.25	500	X019	X014a Weight = 6 g	TO-247AD 
► IXFH88N30P		88	0.04	6300	180	200	0.21	600	X014a		
► IXFK88N30P		88	0.04	6300	180	200	0.21	600	X020		
► IXFK102N30P		102*	0.033	7500	224	200	0.18	700	X020		
► IXFR102N30P		60	0.036	7500	224	200	0.5	250	X016a		
► IXFN102N30P		102*	0.033	7500	224	200	0.18	700	X027a	X015 Weight = 5 g	PLUS247 
► IXFK140N30P		140*	0.024	14000	185	200	0.12	1040	X020		
► IXFN140N30P		140*	0.024	14000	185	200	0.18	700	X027a		
► IXFR140N30P		82*	0.027	14000	185	200	0.35	360	X016a		
► IXFX140N30P		140*	0.024	14000	185	200	0.12	1040	X015		

PolarHV™ HiPerFETs with Fast Intrinsic Diode

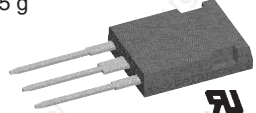
High Voltage Types

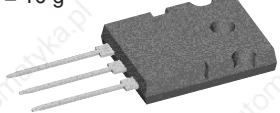
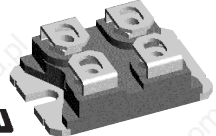
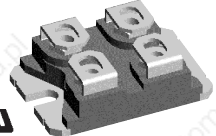
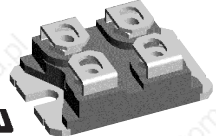







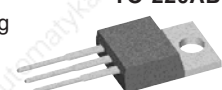
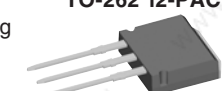

Part Type	V _{DSS} max	I _D (cont) max T _C =25°C	R _{DS(on)} max T _C =25°C	C _{iss} typ	Q _g typ	t _{rr} max	R _{thJC} max	P _D	Fig. No	Package style	
► New	V	A	Ω	pF	nC	ns	K/W	W	Fig. No	Outline drawings on pages 188 - 224	
► IXFP3N50PM	500	2.7	2	409	9.3	200	3.5	36	X007a	X016a Weight = 5 g	ISOPLUS247™ 
► IXFP5N50PM		3.2	1.4	600	12	200	3.3	38	X007a		
► IXFP8N50PM		4	0.8	1200	21	200	3	41	X007a		
► IXFP12N50P		12	0.5	1689	30	200	0.62	200	X005a		
► IXFA12N50P		12	0.5	1689	30	200	0.62	200	X011b		
► IXFP12N50PM		5.4	0.55	1689	30	200	2.5	50	X007a	X019 Weight = 5 g	TO-268AA 
► IXFP16N50P		16	0.4	2250	43	200	0.42	300	X005a		
► IXFA16N50P		16	0.4	2250	43	200	0.42	300	X011b		
► IXFH16N50P		16	0.4	2250	43	200	0.42	300	X014a		
► IXFC16N50P		10	0.45	2250	43	200	1.25	100	X010a		
► IXFV22N50P		22	0.27	3150	50	200	0.35	350	X009	X020 Weight = 10 g	TO-264 
► IXFV22N50PS		22	0.27	3150	50	200	0.35	350	X013		
► IXFH22N50P		22	0.27	3150	50	200	0.35	350	X014a		
► IXFV26N50P		26	0.23	3600	60	200	0.31	400	X009		
► IXFV26N50PS		26	0.23	3600	60	200	0.31	400	X013		
► IXFH26N50P		26	0.23	3600	60	200	0.31	400	X014a	X027a Weight = 30 g	SOT-227B miniBLOC 
► IXFC26N50P		15	0.26	3600	60	200	0.95	130	X010a		
► IXFV30N50P		30	0.2	4000	72	200	0.27	470	X009		
► IXFV30N50PS		30	0.2	4000	72	200	0.27	470	X013		
► IXFH30N50P		30	0.2	4000	72	200	0.27	470	X014a		
► IXFT30N50P		30	0.2	4000	72	200	0.27	470	X019	X019 Weight = 30 g	SOT-227B miniBLOC 
► IXFV36N50P		36	0.17	4800	82	200	0.23	550	X009		
► IXFV36N50PS		36	0.17	4800	82	200	0.23	550	X013		
► IXFH36N50P		36	0.17	4800	82	200	0.23	550	X014a		
► IXFT36N50P		36	0.19	4800	82	200	0.23	550	X019		
► IXFC36N50P		19	0.17	4800	82	200	0.75	166	X010a	X019 Weight = 30 g	SOT-227B miniBLOC 
► IXFR36N50P		24	0.2	4800	82	200	0.8	156	X016a		
► IXFH44N50P		44	0.14	5500	104	200	0.19	670	X014a		
► IXFT44N50P		44	0.14	5500	104	200	0.19	670	X019		
► IXFK44N50P		44	0.14	5500	104	200	0.19	670	X020		

Note 1 - performance and availability are subject to change at the discretion of IXYS

Note 2. * - Drain and source currents may be limited by external package leads.

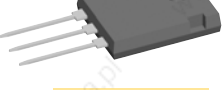
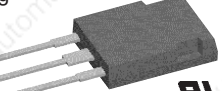
PolarHV™ HiPerFETs with Fast Intrinsic Diode

High Voltage Types

Part Type	V _{DSS} max	I _D (cont) max T _C =25°C	R _{DS(on)} max T _C =25°C	C _{iss} typ	Q _g typ	t _{rr} max	R _{thJC} max	P _D	Fig. No	Package style
> New	V	A	Ω	pF	nC	ns	K/W	W		Outline drawings on pages 188 - 224
> IXFR44N50P	500	24	0.15	5500	104	200	0.6	210	X016a	X005a Weight = 4 g
> IXFX64N50P		64	0.085	7000	150	200	0.42	830	X015	
> IXFK64N50P		64	0.085	7000	150	200	0.15	830	X020	TO-220AB 
> IXFR64N50P		35	0.1	7000	150	200	0.42	300	X016a	
> IXFN64N50P		52	0.085	7000	150	200	0.2	625	X027a	X008 Weight = 3 g
> IXFN64N50PD2**		52	0.086	7000	150	200	0.2	830	X027a	
> IXFX80N50P		80	0.065	8000	200	200	0.12	1040	X015	TO-262 i2-PAC 
> IXFR80N50P		45	0.07	8000	200	200	0.35	360	X016a	
> IXFK80N50P		80	0.065	8000	200	200	0.12	1040	X020	X009 Weight = 4 g
> IXFN80N50P		66	0.065	12700	195	200	0.18	694	X027a	
> IXFB100N50P		100	0.05	20000	240	200	0.1	1250	X021	PLUS220 
> IXFL100N50P		70	0.055	20000	240	200	0.2	625	X022	
> IXFN100N50P		100	0.05	20000	240	200	0.12	1040	X027a	X010a Weight = 3 g
> IXFP10N60P	600	10	0.74	1500	30	200	0.62	200	X005a	
> IXFA10N60P		10	0.74	1500	30	200	0.62	200	X011b	ISOPLUS220™ 
> IXFP14N60P		14	0.55	2300	38	200	0.42	300	X005a	
> IXFA14N60P		14	0.55	2300	38	200	0.42	300	X011b	X010a Weight = 3 g
> IXFH14N60P		14	0.55	2300	38	200	0.42	300	X014a	
> IXFC14N60P		8	0.6	2200	40	200	1.25	100	X010a	TO-263AB 
> IXFV18N60P		18	0.4	3000	50	200	0.35	360	X009	
> IXFV18N60PS		18	0.4	3000	50	200	0.35	360	X013	X011b Weight = 2 g
> IXFH18N60P		18	0.4	3000	50	200	0.35	360	X014a	
> IXFV22N60P		22	0.33	3600	60	200	0.31	400	X009	TO-263AB 
> IXFV22N60PS		22	0.33	3600	60	200	0.31	400	X013	
> IXFH22N60P		22	0.33	3600	60	200	0.31	400	X014a	X013 Weight = 4 g
> IXFC22N60P		12	0.36	3600	105	200	0.95	130	X010a	
> IXFV26N60P		26	0.27	4000	72	200	0.27	460	X009	PLUS220 SMD 
> IXFV26N60PS		26	0.27	4000	72	200	0.27	460	X013	
> IXFH26N60P		26	0.27	4000	72	200	0.27	460	X014a	X014a Weight = 6 g
> IXFT26N60P		26	0.27	4000	72	200	0.27	460	X019	
> IXFV30N60P		30	0.24	4800	82	200	0.23	540	X009	TO-247AD 
> IXFV30N60PS		30	0.24	4800	82	200	0.23	540	X013	
> IXFH30N60P		30	0.24	4800	82	200	0.23	540	X014a	X016a Weight = 5 g
> IXFT30N60P		30	0.24	4800	82	200	0.23	540	X019	
> IXFC30N60P		17	0.25	4800	82	200	0.8	160	X010a	ISOPLUS247™ 
> IXFR30N60P		17	0.25	4800	82	200	0.8	160	X016a	
> IXFH36N60P		36	0.19	5800	102	200	0.19	650	X014a	X017a Weight = 5 g
> IXFT36N60P		36	0.19	5800	102	200	0.19	650	X019	
> IXFK36N60P		36	0.19	5800	102	200	0.19	650	X020	TO-3P 
> IXFR36N60P		20	0.2	5800	103	200	0.6	208	X016a	
> IXFX48N60P		48	0.14	8860	150	200	0.15	830	X015	X019 Weight = 5 g
> IXFK48N60P		48	0.14	8860	150	200	0.15	830	X020	
> IXFR48N60P		32	0.15	8860	150	200	0.42	300	X016a	TO-268AA 
> IXFN48N60P		40	0.14	8860	150	200	0.2	625	X027a	
> IXFK64N60P		64	0.095	12000	200	200	0.12	1040	X020	X020 Weight = 10 g
> IXFN64N60P		50	0.095	12000	200	200	0.18	694	X027a	
> IXFR64N60P		36	0.1	12000	200	200	0.35	360	X016a	TO-264 
> IXFX64N60P		64	0.095	12000	200	200	0.12	1040	X015	
> IXFB82N60P		82	0.075	23000	240	200	0.1	1250	X021	
> IXFL82N60P		54	0.08	23000	240	200	0.2	625	X022	
> IXFN82N60P		82	0.075	23000	240	200	0.12	1040	X027a	

X021
Weight = 10 g

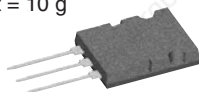

PLUS264

X022
Weight = 10 g

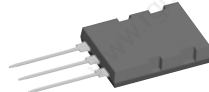

ISOPLUS264

X019
Weight = 5 g

TO-268AA



X020
Weight = 10 g

TO-264

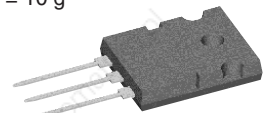





Note 1. Performance and availability are subject to change at the discretion of IXYS

Note 2. ** - MOSFET and FRED diode chips connected in "boost" configuration.

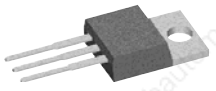
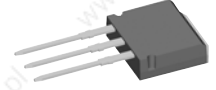
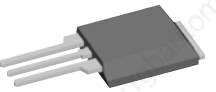
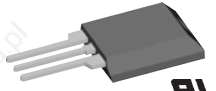
PolarHV™ HiPerFETs with Fast Intrinsic Diodes

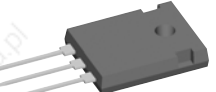
High Voltage Types

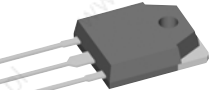
Part Type	V _{DSS} max	I _D (cont) max T _C =25°C	R _{DS(on)} max T _C =25°C	C _{iss} typ	Q _g typ	t _{rr} max	R _{thJC} max	P _D	Fig. No	Package style	
► New	V	A	Ω	pF	nC	ns	K/W	W		Outline drawings on pages 188 - 224	
► IXFA7N80P	800	7	1.4	1500	30	250	0.62	200	X011b	X005a Weight = 4 g	TO-220AB 
► IXFI7N80P		7	1.4	1500	30	250	0.62	200	X008		
► IXFP7N80P		7	1.4	1500	30	250	0.62	200	X005a	X007a	
► IXFP7N80PM		4	1.5	1500	30	250	2.5	50	X007a		
► IXFA10N80P		10	1.1	2300	40	250	0.42	300	X011b	X008 Weight = 5 g	TO-262 i2-PAC 
► IXFC10N80P		5	1.2	2300	40	250	1.25	100	X010a		
► IXFH10N80P		10	1.1	2300	40	250	0.42	300	X014a	X005a	
► IXFP10N80P		10	1.1	2300	40	250	0.42	300	X017a		
► IXFQ10N80P		10	1.1	2300	40	250	0.42	300	X017a	X009 Weight = 4 g	PLUS220 
► IXFC12N80P		7	0.93	3000	50	250	1.05	120	X010a		
► IXFH12N80P		12	0.85	3000	50	250	0.35	360	X014a	X009	
► IXFQ12N80P		12	0.85	3000	50	250	0.35	360	X017a		
► IXFV12N80P		12	0.85	3000	50	250	0.35	360	X009	X013	
► IXFV12N80PS		12	0.85	3000	50	250	0.35	360	X013		
► IXFC14N80P		8	0.77	3600	60	250	0.95	130	X010a	X010a Weight = 3 g	ISOPLUS220™ 
► IXFH14N80P		14	0.7	3600	60	250	0.31	400	X014a		
► IXFQ14N80P		14	0.7	3600	60	250	0.31	400	X017a	X019	
► IXFT14N80P		14	0.7	3600	60	250	0.31	400	X019		
► IXFV14N80P		14	0.7	3600	60	250	0.31	400	X009	X013	
► IXFV14N80PS		14	0.7	3600	60	250	0.31	400	X013		
► IXFC16N80P		9	0.66	4000	70	250	0.9	138	X010a	X011b Weight = 2 g	TO-263AB 
► IXFH16N80P		16	0.6	4000	70	250	0.27	460	X014a		
► IXFT16N80P		16	0.6	4000	70	250	0.27	460	X019	X009	
► IXFV16N80P		16	0.6	4000	70	250	0.27	460	X009		
► IXFV16N80PS		16	0.6	4000	70	250	0.27	460	X013	X014a	
► IXFC20N80P		10	0.55	4800	80	250	0.8	160	X010a		
► IXFH20N80P		20	0.5	4800	80	250	0.23	540	X014a	X016a	
► IXFR20N80P		10	0.55	4800	80	250	0.8	160	X016a		
► IXFT20N80P		20	0.5	4800	80	250	0.23	540	X019	X009	
► IXFV20N80P		20	0.5	4800	80	250	0.23	540	X009		
► IXFV20N80PS		20	0.5	4800	80	250	0.23	540	X013	X014a	
► IXFH24N80P		24	0.4	5800	100	250	0.19	650	X014a		
► IXFK24N80P		24	0.4	5800	100	250	0.19	650	X020	X016a	
► IXFR24N80P		14	0.44	5800	100	250	0.6	208	X016a		
► IXFT24N80P		24	0.4	5800	100	250	0.19	650	X019	X014a	
► IXFK32N80P		32	0.27	8860	135	250	0.15	830	X020		
► IXFN32N80P		29	0.27	8860	135	250	0.2	625	X027a	X014a Weight = 6 g	TO-247AD 
► IXFR32N80P		20	0.29	8860	135	250	0.42	300	X016a		
► IXFX32N80P		32	0.27	8860	135	250	0.15	830	X015	X020	
► IXFK44N80P		44	0.19	12000	200	250	0.12	1040	X020		
► IXFN44N80P		36	0.19	12000	200	250	0.18	694	X027a	X016a Weight = 5 g	ISOPLUS247™ 
► IXFR44N80P		26	0.20	12000	200	250	0.35	360	X016a		
► IXFX44N80P		44	0.19	12000	200	250	0.12	1040	X015	X021	
► IXFB60N80P		60	0.14	23000	265	250	0.1	1250	X021		
► IXFL60N80P		42	0.15	23000	265	250	0.2	625	X022	X017a Weight = 5 g	TO-3P 
► IXFN60N80P		54	0.14	23000	265	250	0.12	1040	X027a		

X019
Weight = 5 g

TO-268AA

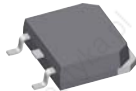

X020
Weight = 10 g

TO-264

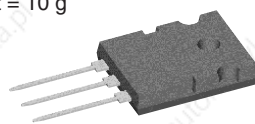

X021
Weight = 10 g

PLUS264

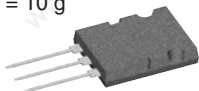

X022
Weight = 10 g

ISOPLUS264

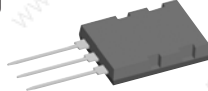

X017a
Weight = 5 g

TO-3P

Note 1 - performance and availability are subject to change at the discretion of IXYS

HiPerFET™ Power MOSFETs with Fast Intrinsic Diode

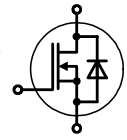

Part Type	V_{DSS} max	I_D (cont) max $T_C=25^\circ\text{C}$	$R_{DS(on)}$ max $T_C=25^\circ\text{C}$	C_{iss} typ	Q_g typ	t_{rr} max	R_{thJC} max	P_D	Fig. No	Package style
	V									
IXFN180N07	70	180*	0.007	9000	480	150	0.24	521	X027a	X005a Weight = 4 g
IXFK180N07		180*	0.006	9400	420	250	0.22	568	X020	
IXFX180N07		180*	0.006	9400	420	250	0.22	568	X015	
IXFN340N07		340*	0.004	12200	490	200	0.18	694	X027a	
IXFN280N085	85	280	0.0044	16000	600	250	0.18	694	X027a	X011b Weight = 2 g
IXFX180N10	100	180*	0.008	9100	360	250	0.22	568	X015	
IXFK180N10		180*	0.008	9100	360	250	0.22	568	X020	
IXFN180N10		180*	0.008	9100	360	250	0.21	595	X027a	
IXFN230N10		230*	0.006	21000	690	250	0.18	694	X027a	
IXFH4N100Q	1000	4	3	1050	39	250	0.8	156	X014a	X014a Weight = 6 g
IXFA4N100Q		4	3	1050	39	250	0.8	156	X011b	
IXFP4N100Q		4	3	1050	39	250	0.8	156	X005a	
IXFT4N100Q		4	3	1050	39	250	0.8	156	X019	
IXFR4N100Q		3.5	3.3	1050	39	250	1.57	80	X016a	X015 Weight = 5 g
IXFX24N100		24	0.39	7000	250	250	0.22	568	X015	
IXFK24N100		24	0.39	7000	250	250	0.22	568	X020	
IXFN24N100		24	0.39	7000	250	250	0.21	595	X027a	
IXFN34N100		34	0.28	9200	380	250	0.18	694	X027a	X015 Weight = 5 g
IXFL34N100		30	0.3	9200	380	250	0.225	556	X022	
IXFN36N100		36	0.24	9200	380	250	0.18	694	X027a	
IXFP3N120		1200	3	4.5	1050	39	300	0.62	200	
IXFA3N120	3		4.5	1050	39	300	0.62	200	X011b	

Note 1. * - Drain and source currents may be limited by external package leads.

Q2-Class HiPerFET™ with Fast Intrinsic Diode

Very High Speed

Part Type	V_{DSS} max	I_D (cont) max $T_C=25^\circ\text{C}$	$R_{DS(on)}$ max $T_C=25^\circ\text{C}$	C_{iss} typ	Q_g typ	t_{rr} max	R_{thJC} max	P_D	Fig. No	Package style
	V									
► New										
IXFR40N50Q2	500	29	0.17	4200	110	250	0.22	560	X016a	X016a Weight = 5 g
IXFH40N50Q2		40	0.16	4200	110	250	0.25	500	X014a	
IXFR66N50Q2		50	0.085	6800	199	250	0.25	500	X016a	X020 Weight = 10 g
IXFN66N50Q2		66	0.08	6800	199	250	0.17	735	X027a	
IXFK66N50Q2		66	0.08	6800	199	250	0.17	735	X020	
IXFX66N50Q2		66	0.08	6800	199	250	0.17	735	X015	
IXFB80N50Q2		80	0.06	10500	260	250	0.14	890	X021	X022 Weight = 10 g
IXFN80N50Q2		80	0.06	10500	260	250	0.14	890	X027a	
► IXFF80N50Q2		80	0.066	10500	260	250	0.33	380	X024c	X022 Weight = 10 g
► IXFL80N50Q2		80	0.066	10500	260	250	0.33	380	X022	
IXFX60N55Q2	550	60	0.088	6900	200	250	0.17	735	X015	X022 Weight = 10 g
IXFK60N55Q2		60	0.088	6900	200	250	0.17	735	X020	
IXFB72N55Q2		72	0.072	10500	258	250	0.14	890	X021	
IXFN72N55Q2		72	0.072	10500	258	250	0.14	890	X027a	
IXFK52N60Q2	600	52	0.115	6800	198	250	0.17	735	X020	X027a Weight = 30 g
IXFX52N60Q2		52	0.115	6800	198	250	0.17	735	X015	
IXFN70N60Q2		70	0.08	7200	265	250	0.14	890	X027a	
IXFB70N60Q2		70	0.08	7200	265	250	0.14	890	X021	
► IXFR38N80Q2	800	28	0.3	8340	190	250	0.3	416	X016a	X027a Weight = 30 g
► IXFK38N80Q2		38	0.22	8340	190	250	0.17	735	X020	
► IXFX38N80Q2		38	0.22	8340	190	250	0.17	735	X015	SOT-227B miniBLOC
IXFB50N80Q2		50	0.15	7200	265	250	0.14	890	X021	
IXFN50N80Q2		50	0.15	7200	265	250	0.14	890	X027a	
► IXFR14N100Q2	1000	9.1	1	2700	83	300	0.62	200	X016a	X027a Weight = 30 g
IXFH14N100Q2		14	0.9	2700	83	300	0.25	500	X014a	
► IXFK30N100Q2		30	0.4	8200	186	300	0.17	735	X020	SOT-227B miniBLOC
► IXFX30N100Q2		30	0.4	8200	186	300	0.17	735	X015	
IXFN38N100Q2		38	0.25	7200	250	300	0.14	893	X027a	
► IXFL38N100Q2		22	0.28	7200	250	300	0.33	380	X022	
IXFB38N100Q2		38	0.25	7200	250	300	0.14	893	X021	

Standard N-Channel Power MOSFETs

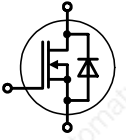

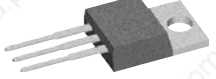

Part Type	V _{DSS} max	I _D (cont) max T _C =25°C	R _{DS(on)} max T _C =25°C	C _{iss} typ	Q _g typ	t _{rr} max	R _{thJC} max	P _D	Fig. No	Package style	
► New	V	A	Ω	pF	nC	ns	K/W	W		Outline drawings on pages 188 - 224	
IXTK250N10	100	250*	0.005	7800	390	150	0.17	730	X020	X003 Weight = 0.3 g	TO-251AA 
IXTY01N80	800	0.1	50	60	8	1500	3	25	X004		
IXTU01N80		0.1	50	60	8	1500	3	25	X003		
IXTY1N80		1	11	220	8.5	710	3.1	40	X004		
IXTP1N80		1	11	220	8.5	710	3.1	40	X005a		
IXTA1N80		1	11	220	8.5	710	3.1	40	X011b		
IXTP2N80		2	6.2	440	22	510	2.3	54	X005a		
IXTA2N80		2	6.2	440	22	510	2.3	54	X011b		
IXTU01N100		1000	0.1	80	60	8	1500	3	25	X003	
IXTY01N100	0.1		80	60	8	1500	3	25	X004		
IXTA05N100	0.75		15	220	8.5	710	3.1	40	X011b		
IXTP05N100	0.75		15	220	8.5	710	3.1	40	X005a		
IXTT1N100	1.5		11	480	23	710	2.3	60	X019		
IXTH1N100	1.5		11	480	23	710	2.3	60	X014a		
IXTA1N100	1.5		11	480	23	710	2.3	54	X011b		
IXTP1N100	1.5		11	480	23	710	2.3	54	X005a		
► IXTP2N100	2	7	825	40	1000	1.25	100	X005a			
IXTP3N120	1200	3	4.5	1050	39	700	0.62	200	X005a	X005a Weight = 4 g	TO-220AB 
IXTA3N120		3	4.5	1050	39	700	0.62	200	X011b		
IXTH3N120		3	4.5	1050	39	700	0.62	200	X014a		
IXTT6N120		6	2.4	1950	56	850	0.42	300	X019		
IXTH6N120		6	2.4	1950	56	850	0.42	300	X014a		
IXTH12N120		12	1.4	3400	95	850	0.25	500	X014a		

Note 1. * - Drain and source currents may be limited by external package leads

N-Channel Depletion-Mode Power MOSFETs

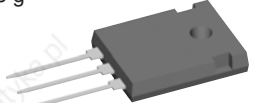
Normally On MOSFETs

Part Type	V _{DSS} max	I _D (cont) max T _C =25°C	R _{DS(on)} max V _{GS} = 0 V	V _{GS(off)} max	C _{iss} typ	C _{rss} typ	R _{thJC} max	P _D	Fig. No	Package style	
► New	V	A	Ω	V	pF	pF	K/W	W		Outline drawings on pages 188 - 224	
► IXTY02N50D	500	0.2	30	-5	120	5	5	25	X004	X004 Weight = 6 g	TO-247AD 
► IXTU02N50D		0.2	30	-5	120	5	5	25	X003		
► IXTP02N50D		0.2	30	-5	120	5	5	25	X005a		
► IXTH20N50D		20	0.33	-3.5	2500	100	0.31	400	X014a		
► IXTT20N50D	20	0.33	-3.5	2500	100	0.31	400	X019			
► IXTY01N100D	1000	0.1	110	-5	120	3	5	25	X004	X019 Weight = 5 g	TO-268AA 
► IXTU01N100D		0.1	110	-5	120	3	5	25	X003		
► IXTP01N100D		0.1	110	-5	120	3	5	25	X005a		
► IXTH10N100D		10	1.4	-3.5	2500	90	0.31	400	X014a		
► IXTT10N100D		10	1.4	-3.5	2500	90	0.31	400	X019		

X020
Weight = 10 g

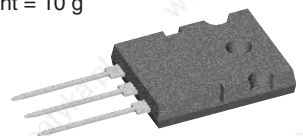

P-Channel Power MOSFETs

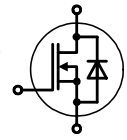

Part Type	V _{DSS} max	I _D (cont) max	R _{DS(on)} max	C _{iss} typ	Q _g typ	t _{rr} typ	R _{thJC} max	P _D	Fig. No	Package style
► New	V	T _C =25°C A	T _C =25°C Ω	pF	nC	ns	K/W	W	Fig.	Outline drawings on pages 188 - 224
IXTH50P085	-85	-50	0.055	4200	150	180	0.42	300	X014a	X014a Weight = 6 g
IXTH36P10 IXTH50P10 ► IXTT50P10	-100	-36 -50 -50	0.075 0.055 0.055	2800 4200 4200	95 140 140	180 180 180	0.65 0.42 0.42	180 300 300	X014a X014a X019	
IXTH16P20 IXTH24P20 ► IXTT24P20	-200	-16 -24 -24	0.16 0.11 0.15	2800 4200 4500	95 150 150	180 250 250	0.42 0.42 0.42	300 300 300	X014a X014a X019	X019 Weight = 5 g
IXTH8P50 ► IXTT8P50 IXTH11P50 IXTT11P50	-500	-8 -8 -11 -11	1.2 1.2 0.75 0.75	3400 3400 4700 4700	130 130 130 130	400 400 500 500	0.65 0.65 0.42 0.42	180 180 300 300	X014a X019 X014a X019	
IXTH10P60	-600	-10	1	4700	160	500	0.42	300	X014a	

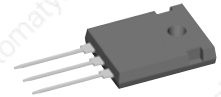

TO-247AD

TO-268AA



Linear Power MOSFETs

High Voltage SOA

Part Type	V _{DSS} max	I _D (cont) max	R _{DS(on)} max	C _{iss} typ	Q _g typ	t _{rr} max	R _{thJC} max	P _D	Fig. No	Package style	
► New	V	T _C =25°C A	T _C =25°C Ω	pF	nC	ns	K/W	W	Fig.	Outline drawings on pages 188 - 224	
► IXTH24N50L ► IXTN46N50L ► IXTK46N50L ► IXTX46N50L ► IXTB62N50L ► IXTN62N50L	500	24 46 46 46 62 62	0.3 0.18 0.18 0.18 0.1 0.1	2500 7000 7000 7000 11500 11500	160 260 260 260 550 550	500 600 600 600 500 500	0.31 0.18 0.18 0.18 0.156 0.156	400 700 700 700 800 800	X014a X027a X020 X015 X021 X027a	X014a Weight = 6 g	
► IXTH12N100L ► IXTX22N100L ► IXTK22N100L ► IXTN22N100L ► IXTB30N100L ► IXTN30N100L	1000	12 24 24 24 30 30	1.3 0.6 0.6 0.6 0.45 0.45	2600 7050 7050 7050 11400 11400	155 270 270 270 530 530	1000 1000 1000 1000 1000 1000	0.31 0.18 0.18 0.18 0.156 0.156	400 700 700 700 800 800	X014a X015 X020 X027a X021 X027a		X015 Weight = 5 g
											X020 Weight = 10 g
											X021 Weight = 10 g
											X027a Weight = 30 g

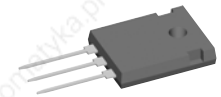

TO-247AD

PLUS247

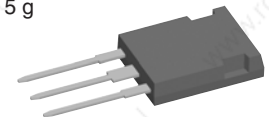

TO-264

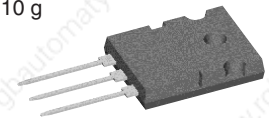

PLUS264

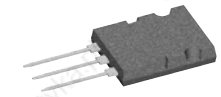

**SOT-227B
miniBLOC**



CoolMOS™ Power MOSFETs

CoolMOS™ is a trademark of Infineon Technologies

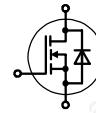

Outline drawings on page 188 - 224

K Series - CoolMOS™

Type	V _{DSS}	I _{D(cont)} T _C = 25°C	R _{DS(on)} max. T _J = 25°C	Q _G typ.	R _{thJC} max.	V _{isol} RMS	Fig. No.	
► New	V	A	Ω	nC	K/W	V		
IXKC20N60C	600	14	0.190	80	1.00	2500	X010a	X005a TO-220AB Weight = 4 g
IXKC40N60C		24	0.096	160	0.50	2500	X010a	
► IXKP35N60C5		35	0.100	60	0.35	-	X005a	X009 PLUS220™ Weight = 4 g
► IXKH35N60C5		35	0.100	60	0.35	-	X014a	
IXKR40N60C		38	0.070	250	0.45	2500	X016a	
IXKN40N60C		40	0.070	250	0.43	2500	X027a	
IXKH47N60C		47	0.070	250	0.30	-	X014a	
► IXKH70N60C5		70	0.045	150	0.20	-	X014a	X010a ISOPLUS220™ Weight = 3 g
IXKN75N60C		75	0.036	500	0.22	2500	X027a	
IXKK85N60C		85*	0.036	540	0.18	-	X020	
IXKC13N80C	800	13	0.290	85	0.96	2500	X010a	
IXKC25N80C		20	0.150	180	0.90	2500	X010a	
IXKR25N80C		25	0.150	170	0.50	2500	X016a	
IXKN45N80C		44	0.074	335	0.33	2500	X027a	X013 PLUS220 SMD Weight = 4 g

Notes: * Silicon chip current rating.

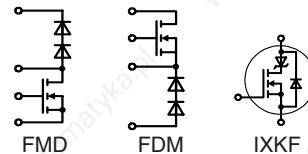

CoolMOS™ configurations in i4-package

Type	V _{DSS}	I _{D(cont)} T _C = 25°C	R _{DS(on)} max. T _J = 25°C	Q _G typ.	R _{thJC} max.	Config.	Fig. No.	
► New	V	A	Ω	nC	K/W			
IXKF40N60SCD1	600	38	0.070	250	0.45	single boost	X024c	X016a ISOPLUS247™ Weight = 5 g
► FMD25-06KC5		25	0.100	under development		boost, SiC	X024a	
► FMD25-06KC5SiC		25	0.100			boost	X024a	
FMD40-06KC		38	0.070	250	0.45	boost	X024a	
► FMD40-06KC5		47	0.045	under development		boost	X024a	
► FDM25-06KC5		25	0.100			buck	X024a	
► FDM25-06KC5SiC		25	0.100			buck, SiC	X024a	
► FDM40-06KC5		47	0.045			buck	X024a	

Trench Gate Power MOSFETs

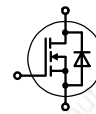

U Series





Type	V _{DSS} Max.	I _{D(cont)} T _C = 25°C	R _{DS(on)} typ T _C = 25°C	Q _{G(on)} typ	t _{rr} typ.	P _D	No.	
► New	V	A	mΩ	nC	ns	W	Fig.	
IXUC100N055	55	100 *	6.1	100	80	150	X010a	
IXUC200N055		200 *	4.0	200	80	250	X010a	X024a ISOPLUS i4-PAC™ Weight = 6 g
IXUC160N075	75	160 *	5.3	250	120	250	X010a	
IXUV170N075		175 *	5.3	250	120	310	X009	
IXUV170N075S		175 *	5.3	250	120	310	X013	
IXUC60N10	100	60 *	12.8	110	80	150	X010a	
IXUC120N10		120 *	7.3	220	80	300	X010a	
► IXUN280N10		280 *	3.9	440	80	770	X027a	
► IXUN350N10		350 *	1.9	640	100	965	X027a	X027a SOT-227B miniBLOC Weight = 30 g

Notes: * Drain and source currents may be limited by external package leads

More Trench Gate MOSFETs are shown in the MOSFET Modules table and the table on the following page.

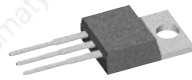
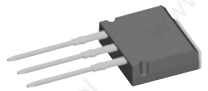
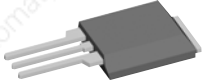
Trench Gate Power MOSFETs

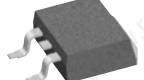
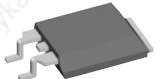
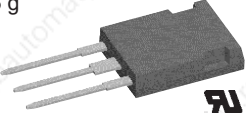
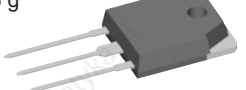
Very Low $R_{DS(on)}$

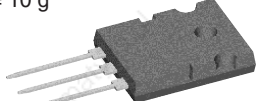
Part Type	V_{DSS} max	I_D (cont) max $T_C=25^\circ C$	$R_{DS(on)}$ max $T_C=25^\circ C$	C_{iss} typ	Q_g typ	t_{rr} max	R_{thJC} max	P_D	Fig. No	Package style	
> New	V	A	Ω	pF	nC	ns	K/W	W		Outline drawings on pages 188 - 224	
> IXTP64N055T	55	64	0.013	1700	60	80	1.25	120	X005a	X005a Weight = 4 g	TO-220AB 
> IXTU64N055T		64*	0.013	1700	60	80	1.25	120	X003		
> IXTY64N055T		64*	0.013	1700	60	80	1.25	120	X004	X008 Weight = 3 g	TO-262 i2-PAC 
> IXTP90N055T		90*	0.008	2600	64	80	1.00	150	X005a		
> IXTU90N055T		90*	0.008	2600	64	80	1.00	150	X003		
> IXTY90N055T		90*	0.008	2600	64	80	1.00	150	X004		
> IXTA110N055T		110*	0.0067	3100	80	80	0.75	200	X011b		
> IXTA110N055T7		110*	0.0067	3100	80	80	0.75	200	X012b		
> IXTP110N055T		110*	0.0067	3100	80	80	0.75	200	X005a	X009 Weight = 4 g	PLUS220 
> IXTA182N055T		182*	0.0044	4850	115	80	0.42	350	X011b		
> IXTA182N055T7		182*	0.0044	4850	115	80	0.42	350	X012b		
> IXTP182N055T		182*	0.0044	4850	115	80	0.42	350	X005a	X010a Weight = 3 g	ISOPLUS220™ 
> IXTQ182N055T		182*	0.0044	4850	115	80	0.42	350	X017a		
> IXTA220N055T		220*	0.0036	5800	175	80	0.37	400	X011b		
> IXTA220N055T7		220*	0.0036	5800	175	80	0.37	400	X012b		
> IXTP220N055T		220*	0.0036	5800	175	80	0.37	400	X005a		
> IXTQ220N055T		220*	0.0036	5800	175	80	0.37	400	X017a		
> IXTA240N055T		240*	0.0033	6900	190	80	0.33	450	X011b	X010a Weight = 3 g	ISOPLUS220™ 
> IXTA240N055T7	240*	0.0033	6900	190	80	0.33	450	X012b			
> IXTC240N055T	140*	0.0036	6900	190	80	1.00	150	X010a			
> IXTQ240N055T	240*	0.0033	6900	190	80	0.33	450	X017a	X011b Weight = 2 g	TO-263AB 	
> IXTP240N055T	240*	0.0033	6900	190	80	0.33	450	X005a			
> IXTC280N055T	164*	0.0030	7900	240	80	0.85	175	X010a			
> IXTH280N055T	280*	0.0028	7900	240	80	0.30	500	X014a			
> IXTQ280N055T	280*	0.0028	7900	240	80	0.30	500	X017a			
> IXTV280N055T	280*	0.0028	7900	240	80	0.30	500	X009			
> IXTV280N055TS	280*	0.0028	7900	240	80	0.30	500	X013	X013 Weight = 4 g	PLUS220 SMD 	
> IXTP55N075T	75	55	0.0017	2100	35	100	1.25	120			X005a
> IXTU55N075T		55*	0.0017	2100	35	100	1.25	120			X003
> IXTY55N075T		55*	0.0017	2100	35	100	1.25	120			X004
> IXTP76N075T		76*	0.0011	2600	64	100	1.00	150			X005a
> IXTU76N075T		76*	0.0011	2600	64	100	1.00	150			X003
> IXTY76N075T		76*	0.0011	2600	64	100	1.00	150			X004
> IXTA98N075T		98*	0.009	3100	80	100	0.75	200			X011b
> IXTA98N075T7		98*	0.009	3100	80	100	0.75	200			X012b
> IXTP98N075T		98*	0.009	3100	80	100	0.75	200			X005a
> IXTA160N075T		160*	0.0055	4850	130	100	0.42	350			X011b
> IXTA160N075T7		160*	0.0055	4850	130	100	0.42	350			X012b
> IXTP160N075T		160*	0.0055	4850	130	100	0.42	350			X005a
> IXTQ160N075T		160*	0.0055	4850	130	100	0.42	350			X017a
> IXTA200N075T		200*	0.0044	5450	139	100	0.37	400			X011b
> IXTA200N075T7		200*	0.0044	5450	139	100	0.37	400			X012b
> IXTP200N075T		200*	0.0044	5450	139	100	0.37	400			X005a
> IXTQ200N075T		200*	0.0044	5450	139	100	0.37	400			X017a
> IXTA220N075T		220*	0.004	6900	190	100	0.33	450	X011b		
> IXTA220N075T7	220*	0.004	6900	190	100	0.33	450	X012b			
> IXTC220N075T	125*	0.0044	6900	190	100	1.00	150	X010a			
> IXTQ220N075T	220*	0.004	6900	190	100	0.33	450	X017a	X016a Weight = 5 g	ISOPLUS247™ 	
> IXTP220N075T	220*	0.004	6900	190	100	0.33	450	X005a			
> IXTC250N075T	150*	0.0037	7900	240	100	0.85	175	X010a			
> IXTH250N075T	250*	0.0034	7900	240	100	0.30	500	X014a			
> IXTQ250N075T	250*	0.0034	7900	240	100	0.30	500	X017a			
> IXTV250N075T	250*	0.0034	7900	240	100	0.30	500	X009			
> IXTV250N075TS	250*	0.0034	7900	240	100	0.30	500	X013	X017a Weight = 5 g	TO-3P 	
> IXTP50N085T	85	50	0.02	2100	35	110	1.25	120			X005a
> IXTU50N085T		50*	0.02	2100	35	110	1.25	120			X003
> IXTY50N085T		50*	0.02	2100	35	110	1.25	120			X004
> IXTP70N085T		70	0.013	2600	64	110	1.00	150			X005a
> IXTU70N085T		70*	0.013	2600	64	110	1.00	150			X003
> IXTY70N085T		70*	0.013	2600	64	110	1.00	150	X004		
> IXTA88N085T		88*	0.011	3100	80	110	0.75	200	X011b		
> IXTA88N085T7		88*	0.011	3100	80	110	0.75	200	X012b		
> IXTP50N085T		50	0.02	2100	35	110	1.25	120	X005a	X019 Weight = 5 g	TO-268AA 
> IXTU50N085T		50*	0.02	2100	35	110	1.25	120	X003		
> IXTY50N085T		50*	0.02	2100	35	110	1.25	120	X004		
> IXTP70N085T		70	0.013	2600	64	110	1.00	150	X005a		
> IXTU70N085T		70*	0.013	2600	64	110	1.00	150	X003		
> IXTY70N085T		70*	0.013	2600	64	110	1.00	150	X004		
> IXTA88N085T		88*	0.011	3100	80	110	0.75	200	X011b	X020 Weight = 10 g	TO-264 
> IXTA88N085T7		88*	0.011	3100	80	110	0.75	200	X012b		

Note 1. Performance and availability are subject to change at IXYS' discretion.
Note 2. * - Drain and source currents may be limited by external package leads.

Trench Gate Power MOSFETs

Very Low $R_{DS(on)}$

Part Type	V_{DSS} max	I_D (cont) max $T_C=25^\circ C$	$R_{DS(on)}$ max $T_C=25^\circ C$	C_{iss} typ	Q_g typ	t_{rr} max	R_{thJC} max	P_D	Fig. No	Package style
> New	V	A	Ω	pF	nC	ns	K/W	W		Outline drawings on pages 188 - 224
> IXTP88N085T	85	88*	0.011	3100	80	110	0.75	200	X005a	X003 Weight = 0.3 g
> IXTA152N085T		152*	0.0066	4850	130	110	0.42	350	X011b	
> IXTA152N085T7		152*	0.0066	4850	130	110	0.42	350	X012b	
> IXTP152N085T		152*	0.0066	4850	130	110	0.42	350	X005a	
> IXTQ152N085T		152*	0.0066	4850	130	110	0.42	350	X017a	
> IXTA180N085T		180*	0.0055	6500	175	110	0.37	400	X011b	
> IXTA180N085T7		180*	0.0055	6500	175	110	0.37	400	X012b	
> IXTP180N085T		180*	0.0055	6500	175	110	0.37	400	X005a	
> IXTQ180N085T		180*	0.0055	6500	175	110	0.37	400	X017a	
> IXTA200N085T		200*	0.005	6900	190	110	0.33	450	X011b	
> IXTA200N085T7		200*	0.005	6900	190	110	0.33	450	X012b	
> IXTC200N085T		110*	0.0055	6900	190	110	1.00	150	X010a	
> IXTQ200N085T		200*	0.005	6900	190	110	0.33	450	X017a	
> IXTP200N085T		200*	0.005	6900	190	110	0.33	450	X005a	
> IXTQ230N085T		136*	0.0045	7900	240	110	0.85	175	X010a	
> IXTH230N085T		230*	0.0041	7900	240	110	0.30	500	X014a	
> IXTQ230N085T	230*	0.0041	7900	240	110	0.30	500	X017a		
> IXTV230N085T	230*	0.0041	7900	240	110	0.30	500	X009		
> IXTV230N85TS	230*	0.0041	7900	240	110	0.30	500	X013		
> IXTP44N10T	100	44	0.025	1800	32	130	1.25	120	X005a	X009 Weight = 4 g
> IXTU44N10T		44*	0.025	1800	32	130	1.25	120	X003	
> IXTY44N10T		44*	0.025	1800	32	130	1.25	120	X004	
> IXTP60N10T		60	0.018	2200	58	130	1.00	150	X005a	
> IXTU60N10T		60*	0.018	2200	58	130	1.00	150	X003	
> IXTY60N10T		60*	0.018	2200	58	130	1.00	150	X004	
> IXTA80N10T		80*	0.013	2600	72	130	0.75	200	X011b	
> IXTA80N10T7		80*	0.013	2600	72	130	0.75	200	X012b	
> IXTP80N10T		80*	0.013	2600	72	130	0.75	200	X005a	
> IXTA130N10T		130*	0.0085	4100	115	130	0.42	350	X011b	
> IXTA130N10T7		130*	0.0085	4100	115	130	0.42	350	X012b	
> IXTP130N10T		130*	0.0085	4100	115	130	0.42	350	X005a	
> IXTQ130N10T		130*	0.0085	4100	115	130	0.42	350	X017a	
> IXTA160N10T		160*	0.0069	5800	155	130	0.37	400	X011b	
> IXTA160N10T7		160*	0.0069	5800	155	130	0.37	400	X012b	
> IXTP160N10T		160*	0.0069	5800	155	130	0.37	400	X005a	
> IXTQ160N10T		160*	0.0069	5800	155	130	0.37	400	X017a	
> IXTA180N10T		180*	0.0061	6200	170	130	0.33	450	X011b	
> IXTA180N10T7		180*	0.0061	6200	170	130	0.33	450	X012b	
> IXTC180N10T		100*	0.0067	6200	170	130	1.00	150	X010a	
> IXTQ180N10T		180*	0.0061	6200	170	130	0.33	450	X017a	
> IXTP180N10T		180*	0.0061	6200	170	130	0.33	450	X005a	
> IXTC200N10T		118*	0.0059	7200	220	130	0.85	175	X010a	
> IXTH200N10T		200*	0.0054	7200	220	130	0.30	500	X014a	
> IXTQ200N10T	200*	0.0054	7200	220	130	0.30	500	X017a		
> IXTV200N10T	200*	0.0054	7200	220	130	0.30	500	X009		
> IXTV200N10TS	200*	0.0054	7200	220	130	0.30	500	X013		

Note 1. Performance and availability are subject to change at IXYS' discretion.

Note 2. * - Drain and source currents may be limited by external package leads.

X016a
Weight = 5 g

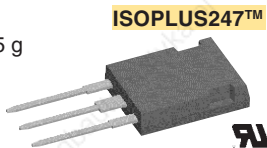

X017a
Weight = 5 g

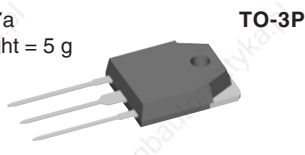

X013
Weight = 4 g



X019
Weight = 5 g



X020
Weight = 10 g

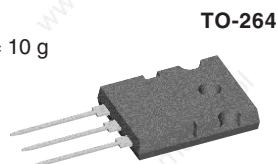

X014a
Weight = 6 g

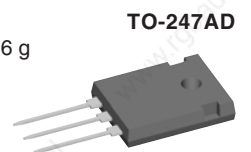

MOSFET Modules

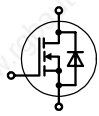

VMO
single
switch

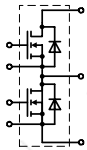

VMM
phase leg

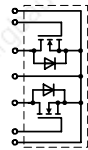

VMK / FMK
dual switch

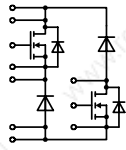

VHM
H-bridge

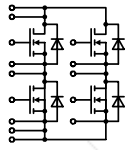

VKM
H-bridge

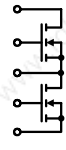

FMM
phase leg





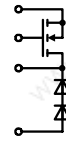



FMD
boost

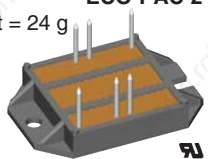
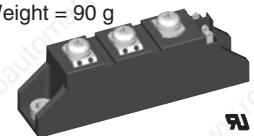

FDM
buck

N Channel Enhancement Types

suffix "F" = HiPerFET™ technology with fast intrinsic diode

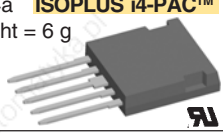
Type	V _{DSS} V	I _{D25} A T _C = 25°C	I _{D80} A T _C = 80°C	R _{DSon} mΩ T _J = 25°C	t _r ns	t _f ns	R _{thJC} K/W	Thermistor	Fig. No.	Package style		
► New												
single switch modules												
VMO150-01P1	100	150	110	8	65	90	0.3		X102	ECO-PAC 2 Weight = 24 g  See data sheet for pin arrangement		
VMO550-01F	100	590	<i>not recommended for new designs</i>					X128				
VMO650-01F	100	690	<i>not recommended for new designs</i>					X128				
► VMO1200-01F	100	1245	930	1.35	200	500	0.039	X130d				
VMO580-02F	200	580	<i>not recommended for new designs</i>					X130d				
VMO40-05P1	500	41	31	100	45	60	0.3	X102				
VMO60-05F	500	60	<i>not recommended for new designs</i>					X125b				
VMO80-05P1	500	82	62	50	45	60	0.16	X102				
dual switch modules - common source configuration												
VMK165-007T	70	165	<i>not recommended for new designs</i>						X125b	TO-240 AA Weight = 90 g 		
FMK75-01F	100	75	50 / 90°C	21	60	60	0.50	X024a				
VMK90-02T2	200	84	<i>not recommended for new designs</i>					X125b				
MOSFET modules - phase leg configuration												
FMM75-01F	100	75	50 / 90°C	21	60	60	0.50		X024a	 Weight 150 g		
VMM650-01F	100	680	<i>not recommended for new designs</i>						X130b			
VMM45-02F	200	45										X125b
VMM85-02F	200	84										X127a
VMM300-03F	300	290										X128
VMM90-09F	900	85	65	76	140	180	0.08	X130b				
MOSFET modules - H bridge configuration												
VHM40-06P1	600	38	25 / 90°C	70	10	95	0.45		X102	 Weight 250 g		
VKM60-01P1	100	75	60	25	60	60	0.5					
VKM40-06P1*	600	38	25	70	10	95	0.45					
MOSFET modules - boost configuration												
FMD21-05QC	500	21	15 / 90°C	180	16	30	1.50		X024a	 Weight = 250 g		
FMD40-06KC *	600	38	25 / 90°C	60	10	30	0.45		X024a			
► FMD25-06KC5 *	600	25	tbd	100	<i>under development</i>				X024a			
► FMD25-06KC5SiC *	600	25		100	<i>under development</i>				X024a			
► FMD40-06KC5 *	600	47		45	<i>under development</i>				X024a			
MOSFET modules - buck configuration												
FDM21-05QC	500	21	15 / 90°C	180	16	30	0.50		X024a	 Weight = 250 g		
► FDM25-06KC5 *	600	25	tbd	100	<i>under development</i>				X024a			
► FDM25-06KC5SiC *	600	25		100	<i>under development</i>				X024a			
► FDM40-06KC5 *	600	47		45	<i>under development</i>				X024a			
*  CoolMOS™ is a trademark of Infineon Technologies												
X024a ISOPLUS i4-PAC™ Weight = 6 g 												

MOSFET Modules

Trench MOSFET Technology

- very low R_{DSon}
- fast body diode

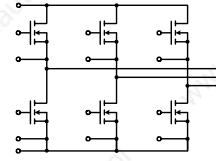

GWM, VWM
sixpack

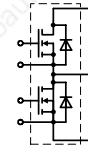

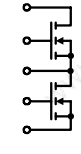

VMM
phase leg

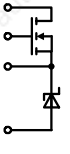

FMM
phase leg

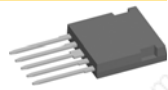
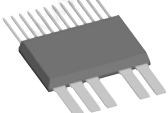

FDM
buck

Type	V_{DSS} V	I_{D25} A	I_{D80} A	R_{DSon} mΩ	t_f ns	t_r ns	R_{thJC} K/W	Fig. No.	Package style
► New	$T_c =$	$T_c =$	$T_j =$	25°C					Outline drawings on page 188 - 224
Phase leg configuration									
FMM300-0055P	55	300	220	2.7	40	50	0.50	X024a	X024a Weight = 6 g ISOPLUS i4-PAC™ 
FMM150-0075P	75	150	120	4.7	60	60	0.60	X024a	
FMM200-0075P	75	200	160	3.5	1170	1020	0.55	X024a	
VMM1500-0075P	75	1500	1200 / 80°C	0.55	200	170	0.06	X130b	X026 Weight = 25 g ISOPLUS-DIL™ 
VMM1000-01P	100	1000	800 / 80°C	0.75	100	100	0.06	X130b	
FMM65-015P	150	65	50	13	100	80	0.60	X024a	
Sixpack configuration									
VWM350-0075P	75	340	250 / 80°C	2.3	200	170	0.26	X104	X104 Weight = 80 g 
VWM200-01P	100	210	170 / 80°C	3.6	100	100	0.26	X104	
GWM220-004P3*	40	220	160	2.8	190	270	0.85	X026	
GWM160-0055P3*	55	160	120	3	50	40	0.85	X026	See data sheet for pin arrangement
GWM120-0075P3*	75	125	100	4.8	50	60	0.85	X026	
► GWM100-0085X1*	85		<i>under development</i>					X026	
GWM70-01P2*	100	70	50 / 80°C	11	70	85	0.85	X026	
► GWM95-01X1*	100		<i>under development</i>					X026	
Buck configuration									
FDM100-0045SP	45	100	80	5.7	155	115	1.0	X024a	
Boost configuration									
FMD80-0045SP	100	70	50	11	70	55	0.85	X024a	X130b Weight = 250 g 

* Bent lead and SMD lead version available, refer to ISOPLUS-DIL pages 59/60

Diodes for High Switching Frequencies

Fast Recovery Epitaxial Diodes (HiPerFRED; FRED)

Power switches (IGBT, MOSFET, BJT, GTO) for applications in electronics are only as good as their associated free-wheeling diodes. At increasing switching frequencies, the proper functioning and efficiency of the power switch, aside from conduction losses, is determined by the turn-off behavior of the diode (characterized by Q_{rr} , I_{RM} and t_{rr} - fig. 1). With optimized ultra-fast switching diodes, the development engineer has various possibilities: either higher pulse rate or higher current load or smaller heatsink or more conservative operation due to "cooler" chips.

The reverse current characteristic following the peak reverse current I_{RM} is another very important property. The slope of the decaying reverse current di_r/dt results from design parameters (technology and diffusion of the diode chips). In a circuit this current slope, in conjunction with parasitic inductances (e.g. connecting leads), causes over-voltage spikes and high frequency interference voltages. The higher the di_r/dt ("hard recovery" or "snap-off" behavior) the higher is the resulting additional stress for both the diode and the paralleled switch. A slow decay of the reverse current ("soft recovery" behavior), is the most desirable characteristic, and this is designed into all diodes. The wide range of available blocking voltages makes it possible to apply these diodes as output rectifiers in switch-mode power supplies (SMPS) as well as protective and free-wheeling diodes for power switches in inverters.

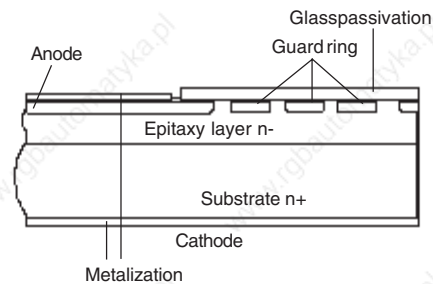

Fig. 2: Cross section of glassivated planar epitaxial diode chip with guard rings (type DWEP)

Diodes for General Purpose Applications

Rectifier Diodes

Diodes of the DS-series (anode on stud) and of the DSI-series (cathode on stud) are mainly used for rectifying 50 or 60 Hz mains currents. Discrete diodes in plastic and metal housings and also different diode bridges are available for standard line voltages (from 100 to 600 V).

Avalanche Diodes

Avalanche diodes or surge-voltage-proof rectifier diodes of the series DSA (anode on stud) and DSAI (cathode on stud) differ from standard diodes of the series DS and DSI in the following manner: the operation in avalanche breakdown above the normal reverse blocking voltage (V_{RRM}) can be tolerated as long as the power is within the specified maximum permissible non-repetitive reverse surge dissipation P_{RSM} at the specified pulse width. In order to have

technologically good control of the avalanche breakdown, it is important to ensure homogeneous doping of the middle zone of the silicon chip and suitable junction termination and passivation at the edges where PN-junctions are exposed to the surface (high field strength at the edge). Because of this ruggedness against periodically occurring short-term voltage surges in the blocking direction, the user frequently can do without protective overvoltage networks. In addition, if avalanche diodes are put in series for high voltage applications, the sharp avalanche breakdown of the blocking characteristic ensures static and dynamic voltage distribution uniformly across each device. Thus, in general, none of the series diodes will be overstressed by reverse voltages which are substantially above the avalanche voltage. All high voltage rectifier modules manufactured in quantity are assembled with avalanche diodes.

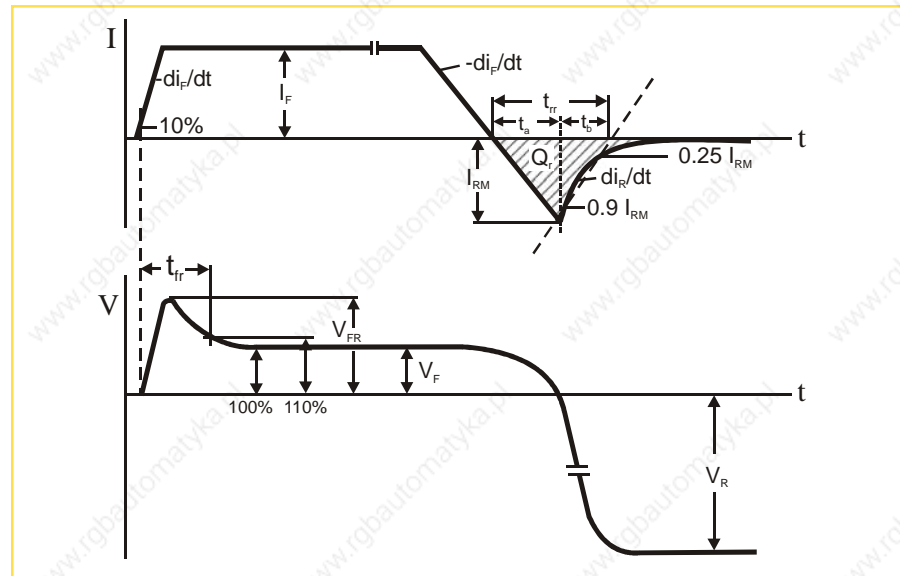

Fig. 1: Current and voltage during turn-on and turn-off switching of fast diodes

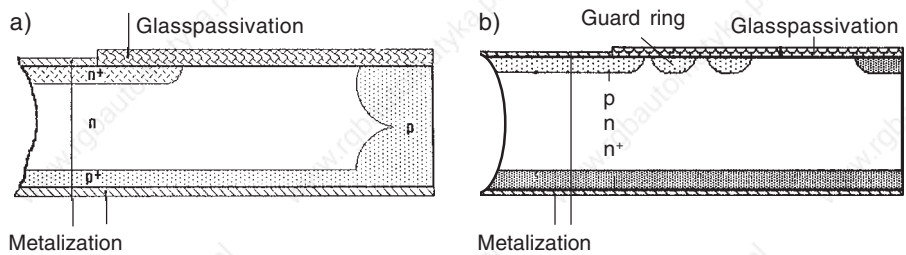
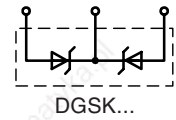

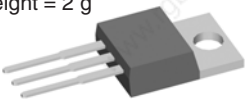
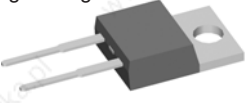

Fig. 3: Cross sections of glassivated planar diode chips with separation diffusion
a) type DWN with Anode on bottom
b) type DWP with Cathode on bottom

Gallium Arsenide Schottky Diodes





No reverse recovery

Type	V _{RRM}	I _{DC} @ T _C	V _F typ. @ I _F T _{VJ} = 125°C	C _J	R _{thJC}	Fig. No.	Package style
► New	V	A °C	V A	pF	K/W		Outline drawings on page 188 - 224
DGS 3-018AS	180	5 90	0.85 2	8.8	8.5	X004	X004 Weight = 0.3 g 
DGS 10-018A	180	11 90	0.8 5	22	4.4	X005b	
DGS 10-018AS	180	11 90	0.8 5	22	4.4	X011b	
DGS 20-018A	180	17 90	0.8 7.5	33	3.1	X005b	
DGS 20-018AS	180	17 90	0.8 7.5	33	3.1	X011b	
DGS 3-025AS	250	3.9 90	1.3 2	6.4	8.5	X004	
DGS 4-025A	250	9 90	1.3 2	6.4	8.5	X005b	
DGS 9-025AS	250	9 90	1.3 5	18	4.4	X004	
DGS 10-025A	250	9 90	1.3 5	18	4.4	X005b	
DGS 10-025AS	250	9 90	1.3 5	18	4.4	X011b	
DGS 19-025AS	250	13 90	1.3 7.5	26	3.1	X004	X005a Weight = 2 g 
DGS 20-025A	250	13 90	1.3 7.5	26	3.1	X005b	
DGS 20-025AS	250	13 90	1.3 7.5	26	3.1	X011b	
DGS 3-030AS	300	3.5 90	1.6 2	3.7	8.5	X004	
DGS 9-030AS	300	8 90	1.6 5	9	4.4	X004	X005b Weight = 2 g 
DGS 10-030A	300	8 90	1.6 5	9	4.4	X005b	
DGSK 20-018A	180	11 90	0.8 5	22	4.4	X005a	
DGSK 40-018A	180	17 90	0.8 7.5	33	3.1	X005a	
DGSK 8-025A	250	3.9 90	1.3 2	6.4	8.5	X005a	
DGSK 20-025A	250	9 90	1.3 5	18	4.4	X005a	
DGSK 20-025AS	250	9 90	1.3 5	18	4.4	X011b	
DGSK 40-025A	250	13 90	1.3 7.5	26	3.1	X005a	
DGSK 40-025AS	250	13 90	1.3 7.5	26	3.1	X011b	

Low leakage current

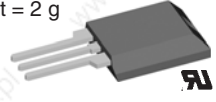
Second generation

Type	V _{RRM}	I _{DC} @ T _C	V _F typ. @ I _F T _{VJ} = 125°C	C _J	R _{thJC}	Fig. No.	Package style
► New	V	A °C	V A	pF	K/W		
DGS 15-018CS	180	15 90	1.0 7.5	21	4.4	X004	X010a ISOPLUS220AB™ Weight = 2 g 
DGS 13-025CS	250	14 90	1.2 7.5	15	4.4		
DGS 19-025CS	250	20 90	1.1 10	24	3.1		
DGS 17-03CS	300	17.5 90	1.1 7.5	10.7	4.4	X011b	X011b Weight = 2 g 
DGSK 32-018CS	180	15 90	1.0 7.5	21	4.4		
DGSK 28-025CS	250	14 90	1.2 7.5	15	4.4		
DGSK 40-025CS	250	20 90	1.1 10	24	3.1		
DGSK 36-03CS	300	17.5 90	1.1 7.5	10.7	4.4	X010a	
► DGSS 6-06CC	600	6 90	1.2 6	4	12.5		
► DGSS 10-06CC	600	15 90	1.2 10	10.7	5.2		
► DGSS 20-06CC	600	23 90	1.2 20	16	3.5		

Silicon Carbide Schottky Diodes

No reverse recovery

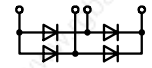

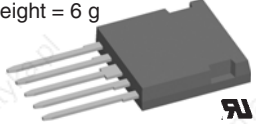

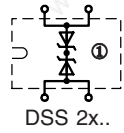
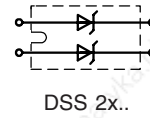
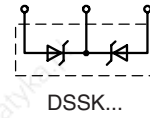
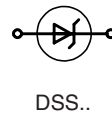
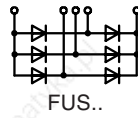

Type	V _{RRM}	I _{DC} @ T _C	V _F typ. @ I _F T _{VJ} = 25...125°C	C _J	R _{thJC}	Fig. No.	Package style
► New	V	A °C	V A	pF	K/W		
FBS 10-06SC	600	3 90	1.7 4	9	8	X024a	X024a ISOPLUS i4-PAC™ Weight = 6 g 
FBS 16-06SC	600	5 90	1.5 6		5.6		

Data according to IEC 60747 and refer to a single diode or thyristor unless otherwise stated.

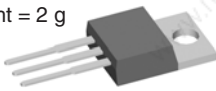
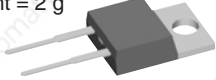
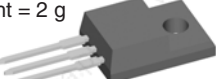
Schottky Diodes

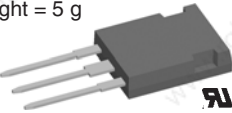
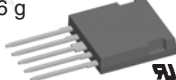



Type	V _{RRM}	I _{FAV} d = 0.5	T _C	V _F @ I _F max.	E _{AS}	I _{AR}	T _{VJM}	R _{thJC}	Fig. No.	Package style
▶ New	V	A	°C	T _{VJM} = 125°C V A	mJ	A	°C	K/W		Outline drawings on page 188 - 224
▶ DSS 40-0008D DSSK 80-0008D DSS 2x200-0008D [Ⓢ]	8	40 2x40 2x200	135 135 100	0.23 40 0.23 40 0.15 100	80 80 80	4 4 4	150 150 150	0.8 0.8 0.4	X014a X014a X027b	X004 Weight = 0.3 g 
DSS 20-0015B DSSK 40-0015B DSSK 70-0015B	15	20 2x20 2x35	135 135 130	0.33 20 0.32 20 0.33 35	tbd tbd 61	tbd tbd 2.5	150 150 150	1.4 1.4 1.1	X005b X014a X014a	X005a Weight = 2 g 
DSS 6-0025BS DSS 25-0025B DSSK 18-0025B DSSK 18-0025BS DSSK 38-0025B DSSK 38-0025BS DSSK 48-0025B DSSK 50-0025B DSSK 80-0025B	25	6 25 2x10 2x10 2x20 2x20 2x25 2x25 2x40	140 125 140 140 130 130 130 125 130	0.30 6 0.44 25 0.37 10 0.37 10 0.40 20 0.40 20 0.35 20 0.42 25 0.39 40	tbd tbd tbd tbd tbd tbd tbd tbd 10	tbd tbd tbd tbd tbd tbd tbd tbd 6.0	150 150 150 150 150 150 150 150 150	3.0 1.4 1.7 1.7 1.4 1.4 1.2 1.4 0.8	X004 X005b X005a X011b X005a X011b X005a X014a X014a	X005b Weight = 2 g 
DSSK 48-003B DSSK 48-003BS DSSK 70-003B DSSK 80-003B	30	2x25 2x25 2x35 2x40	130 130 125 130	0.35 20 0.35 20 0.39 35 0.39 40	tbd tbd tbd 10	tbd tbd tbd 6.0	150 150 150 150	1.2 1.2 1.1 0.8	X005a X011b X014a X014a	X007a Weight = 2 g 
DSS 6-0045AS DSS 10-0045A DSS 10-0045B DSS 16-0045A DSS 16-0045AS DSS 16-0045B DSS 25-0045A DSS 60-0045B DSSK 20-0045A DSSK 20-0045AM DSSK 20-0045B DSSK 28-0045A DSSK 28-0045B DSSK 28-0045BS DSSK 30-0045A DSSK 30-0045B DSSK 60-0045A DSSK 60-0045B DSSK 80-0045B DSS 2x61-0045A DSS 2x81-0045B DSS 2x121-0045B DSS 2x160-0045A [Ⓢ]	45	6 10 10 16 16 16 25 60 2x10 2x10 2x10 2x14 2x15 2x15 2x15 2x15 2x15 2x30 2x30 2x40 2x60 2x80 2x120 2x160	165 160 135 160 160 130 155 100 160 145 135 160 135 135 135 160 120 125 105 75 100 100	0.50 6 0.56 10 0.46 10 0.56 16 0.56 16 0.44 16 0.56 25 0.57 60 0.58 10 0.56 10 0.45 10 0.57 15 0.43 15 0.43 15 0.57 15 0.41 15 0.60 30 0.44 30 0.45 40 0.65 60 0.64 80 0.59 120 0.73 160	24 24 24 32 32 32 46 57 24 11 24 32 32 32 32 32 46 46 57 57 57 112 112	1.3 1.3 1.3 1.5 1.5 1.5 1.8 2.0 1.3 1.5 1.3 1.5 1.5 1.5 1.5 1.5 1.8 1.8 2.0 2.0 2.0 2.8 2.8	175 175 150 175 175 150 175 150 175 175 150 175 150 150 175 150 150 150 150 150 150 150 150 150	3.0 1.7 1.7 1.4 1.4 1.4 1.1 0.8 1.7 4.3 1.7 1.4 1.4 1.4 1.4 1.4 1.1 1.1 0.8 0.8 0.8 0.4 0.3	X004 X005b X005b X005b X011b X005b X005b X014b X005a X007a X005a X005a X005a X011b X014a X014a X014a X014a X014a X014a X027a X027a X027a X027b	X011b Weight = 2 g 
FUS 45-0045B		45	90	0.5 typ. 15	tbd	tbd	150	3.1	X024a	X016a Weight = 5 g 
DSS 10-006A DSSK 28-006B DSSK 28-006BS DSSK 40-006B DSSK 80-006B	60	10 2x15 2x15 2x20 2x40	160 135 135 130 120	0.62 10 0.52 15 0.52 15 0.46 20 0.51 40	0.05 5 5 20 20	0.1 1 1 2 2	175 150 150 150 150	1.6 1.4 1.4 1.1 0.8	X005b X005a X011b X014a X014a	X024a Weight = 6 g 
▶ DSSK 80-006BR		2x40	120	0.51 40	20	2	150	0.8	X016a	X027a/b Weight = 30 g 

Data per Diode unless otherwise specified
[Ⓢ] non isolated base plate

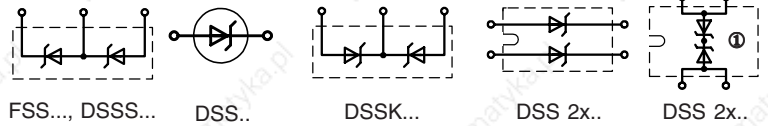
Schottky Diodes

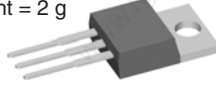
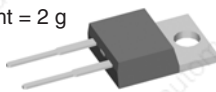
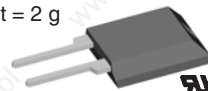

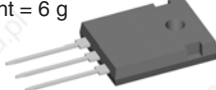
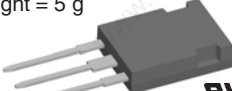
Type	V _{RRM}	I _{FAV} @ d = 0.5	T _C	V _F @ I _F max. T _{VJM} = 125°C	E _{AS}	I _{AR}	T _{VJM}	R _{thJC}	Fig. No.	Package style
► New	V	A	°C	V A	mJ	A	°C	K/W		Outline drawings on page 188 - 224
DSSK 40-008B	80	2x20	130	0.52 20	20	2	150	1.1	X014a	X004 Weight = 0.3 g 
► DSSS 35-008AR		35	150	0.68 35	60	2	175	0.8	X016a	
DSSK 70-008A		2x35	150	0.64 35	tbd	tbd	175	0.8	X014a	
► DSSK 70-008AR		2x35	150	0.64 35	61	3.5	175	0.8	X016a	
DSS 2x111-008A		2x110	105	0.72 100	19	1.4	150	0.4	X027a	
FSS 100-008A		85	90	0.80 75	tbd	tbd	175	1.4	X024b	
DSS 10-01A		10	160	0.66 10	1.3	0.8	175	1.7	X005b	X005a Weight = 2 g 
DSS 10-01AS		10	160	0.66 10	1.3	0.8	175	1.7	X011b	
DSS 16-01A		16	155	0.65 16	5	1.0	175	1.4	X005b	X005b Weight = 2 g 
DSS 16-01AS		16	155	0.65 16	5	1.0	175	1.4	X011b	
DSS 20-01AC		20	140	0.76 20	7	0.8	175	1.7	X010b	X010b Weight = 2 g 
► DSSS 30-01AR		30	155	0.63 30	11	1.5	175	0.8	X016a	
DSSK 16-01A		2x8	165	0.63 8	1.3	0.8	175	1.7	X005a	
DSSK 16-01AS		2x8	165	0.63 8	1.3	0.8	175	1.7	X011b	
DSSK 28-01A		2x15	160	0.64 15	5	1.0	175	1.4	X005a	
DSSK 28-01AS		2x15	160	0.64 15	5	1.0	175	1.4	X011b	
DSSK 30-01A		2x15	160	0.63 15	5	1.0	175	1.4	X014a	
DSSK 50-01A		2x25	155	0.64 25	5	1.0	175	1.1	X014a	
DSS 2x41-01A		2x40	110	0.70 40	5	1.0	150	1.1	X027a	
DSS 2x61-01A		2x60	105	0.74 60	11	1.5	150	0.8	X027a	
DSS 2x160-01A ①		2x160	95	0.81 160	11	1.5	150	0.3	X027b	
DSS 6-015AS	150	6	160	0.62 6	0.05	0.1	175	3.0	X004	X011b Weight = 2 g 
DSSK 20-015A		2x10	165	0.65 10	0.2	0.2	175	1.4	X005a	
DSSK 50-015A		2x25	150	0.68 25	tbd	tbd	175	1.1	X014a	
DSSK 60-015A		2x30	155	0.66 30	0.8	0.4	175	0.8	X014a	
DSSK 60-015AR		2x30	155	0.66 30	0.8	0.4	175	0.8	X016a	
DSS 2x101-015A	150	2x100	110	0.77 100	0.8	0.4	150	0.4	X027a	X014a Weight = 6 g 
DSSK 10-018A	180	2x5	165	0.62 5	tbd	tbd	175	1.7	X005a	
DSSK 30-018A		2x15	150	0.72 15	tbd	tbd	175	1.7	X014a	
► DSSK 60-02A	200	2x30	155	0.70 30	0.8	0.4	175	0.8	X014a	X016a Weight = 5 g 
► DSSK 60-02AR		2x30	155	0.70 30	0.8	0.4	175	0.8	X016a	
► DSS 2x101-02A		2x100	105	0.84 100	tbd	tbd	150	0.4	X027a	

Data per Diode unless otherwise specified
 ① non isolated base plate

X016a **ISOPLUS247™**
Weight = 5 g

X024b **ISOPLUS i4-PAC™**
Weight = 6 g

X027a/b **SOT-227B miniBLOC**
Weight = 30 g

Schottky Gen² Diodes

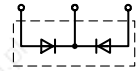

$I_{FAV} = 1 - 120 A$



DS...IM...

DS...I...

DS...C...

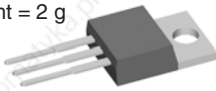
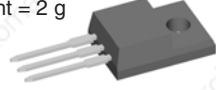
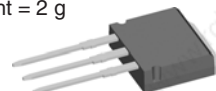
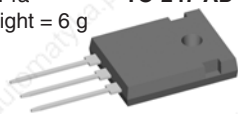
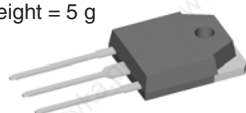
Type	V_{RRM}	I_{FAV} $d = 0.5$	T_C	V_F max.	I_F	E_{AS}	I_{AR}	T_{VJM}	R_{thJC}	Fig. No.	Package style
► New	V	A	°C	$T_{VJM} = 125^\circ C$ V	A	mJ	A	°C	K/W		Outline drawings on page 188 - 224
► DSB 20I15PA ► DSB 40C15PB	15	20 2x20	125 125	0.45 0.45	20 20	tbd	tbd	150	1.75 1.75	X005b X005a	X001 SMA (DO-214AC) Weight = 0.07 g 
► DSB 30C30PB ► DSB 60C30HB	30	2x15 2x30	130 125	0.44 0.47	15 30	tbd	tbd	150	1.75 0.95	X005a X014a	
► DSB 1I40SA ► DSB 2I40SB	40	1 2	125 125	0.40 0.42	1 2	tbd	tbd	150	$R_{thJL} 40$ $R_{thJL} 25$	X001 X002	X002 SMB (DO-214AA) Weight = 0.1 g 
► DSB 10I45PM ► DSA 20C45PB ► DSA 15I45PA ► DSA 15IM45IB ► DSB 15IM45IB ► DSA 30C45PB ► DSB 30C45PB ► DSA 30C45HB ► DSB 30C45HB ► DSA 60C45PB ► DSB 60C45PB ► DSA 60C45HB ► DSB 60C45HB ► DSA 80C45HB ► DSB 80C45HB	45	10 2x10 15 15 15 2x15 2x15 2x15 2x15 2x30 2x30 2x30 2x30 2x40 2x40	115 155 155 155 125 155 125 155 125 150 125 150 125 150 125	0.53 0.62 0.63 0.63 0.55 0.63 0.55 0.62 0.54 0.67 0.60 0.66 0.58 0.67 0.58	10 10 15 15 15 15 15 15 15 30 30 30 30 40 40	tbd	tbd	150 175 175 175 150 175 150 175 150 175 150 175 150 175 150 150	4.50 2.60 1.75 1.75 1.75 1.75 1.75 1.75 1.75 0.85 0.85 0.95 0.95 0.70 0.70	X007b X005a X005b X008 X008 X005a X005a X014a X014a X005a X005a X014a X014a X014a X014a	X005a TO-220AB Weight = 2 g 
► DSB 1I60SA ► DSB 2I60SB ► DSA 20C60PN ► DSB 20C60PN ► DSA 30C60PB ► DSB 30C60PB ► DSA 60C60PB ► DSB 60C60PB ► DSA 60C60HB ► DSB 60C60HB	60	1 2 2x10 2x10 2x15 2x15 2x30 2x30 2x30 2x30	125 125 140 115 150 125 150 125 150 125	0.50 0.52 0.68 0.63 0.70 0.69 0.74 0.69 0.72 0.67	1 2 10 10 15 15 30 30 30 30	tbd	tbd	150 150 175 150 175 150 175 150 175 150	$R_{thJL} 40$ $R_{thJL} 25$ 4.50 4.50 1.75 1.75 0.85 0.85 0.95 0.95	X001 X002 X007a X007a X005a X005a X005a X005a X014a X014a	X007a TO-220ABFP Weight = 2 g 
► DSA1I100SA ► DSA2I100SB ► DSA20C100PB ► DSA20C100PN ► DSA30C100PB ► DSA30C100PN ► DSA30C100QB ► DSA50C100HB ► DSA50C100QB ► DSA60C100PB ► DSA70C100HB ► DSA80C100PB	100	1 2 2x10 2x10 2x15 2x15 2x15 2x25 2x25 2x30 2x35 2x40	125 125 150 140 150 120 150 155 155 150 150 150	0.65 0.65 0.72 0.72 0.73 0.73 0.72 0.72 0.72 0.78 0.74 0.73	1 2 10 10 15 15 15 25 25 30 35 40	tbd	tbd	175	$R_{thJL} 40$ $R_{thJL} 25$ 2.60 4.50 1.75 4.20 1.75 0.95 0.95 0.85 0.70 0.60	X001 X002 X005a X007a X005a X007a X017a X014a X017a X005a X014a X005a	X008 TO-262 (i2-Pac) Weight = 2 g 
► DSA20C150PB ► DSA20C150PN ► DSA30C150PB ► DSA50C150HB ► DSA70C150HB ► DSA120C150QB	150	2x10 2x10 2x15 2x25 2x35 2x60	150 140 150 155 150 150	0.74 0.74 0.75 0.74 0.74 0.80	10 10 15 25 35 60	tbd	tbd	175	2.60 4.50 1.75 0.95 0.70 0.40	X005a X007a X005a X014a X014a X017a	X014a TO-247 AD Weight = 6 g 
► DSA90C200HB	200	2x45	150	0.88	45	tbd	tbd	175	0.55	X014a	X017a TO-3P Weight = 5 g 

HiPerDyn™ FRED

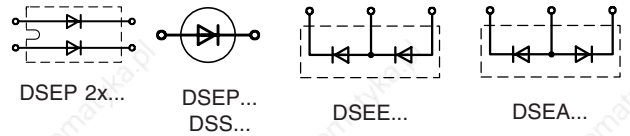

Series connected diodes for high switching frequencies;
packages isolated (2500 V_{RMS})

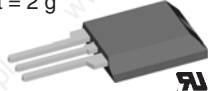
Type	V _{RRM}	I _{FAV} @ T _C d = 0.5	V _F @ T _{VJ} max.	t _{rr} typ. T _{VJ} = 25°C	I _{RM} typ. T _{VJ} = 100°C	T _{VJM}	R _{thJC}	Fig. No.	Package style
	V	A °C	V °C	ns	A A/μs	°C	K/W		Outline drawings on page 188 - 224
DSEP 9-06CR DSS 17-06CR * DSEP 30-06CR	600	9 140 17 95 30 140	2.9 150 2.71 125 2.25 150	15 45 15	3.5 100 4.0 100 2.5 100	175 175 175	1.0 1.4 0.6	X016b	X010a ISOPLUS220AB™ Weight = 2 g 
DSEP 15-12CR DSEP 30-12CR	1200	15 130 30 115	2.67 150 3.1 150	20 20	4.0 100 4.0 100	175 175	1.0 0.6		
DSEP 2x35-06 C	600	35 100	1.97 125	20	4.5 100	150	0.6	X027a	
DSEP 2x25-12 C	1200	25 90	3.0 125	20	3.0 100	150	0.6		

* series connected Schottky Diodes

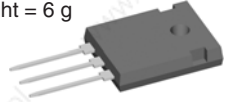
X014a **TO-247 AD**
Weight = 6 g

X016b **ISOPLUS247™**
Weight = 5 g



Dual Ultrafast Diodes

Series connected diodes for high switching frequencies with middle connection; packages isolated (2500 V_{RMS})

Type	V _{RRM}	I _{FAV} @ T _C d = 0.5	V _{Fmax} @ T _{VJ} I _F = I _{FAV}	t _{rr} typ. T _J = 25°C	I _{RM} typ @ -di/dt T _J = 100°C	T _{VJM}	R _{thJC}	Fig. No.
► New	V	A °C	V °C	ns	A A/μs	°C	K/W	
DSEE 6-06CC DSEE 8-06CC DSEE 15-06CC DSEE 29-06CC	2x300	6 150 10 130 15 115 30 115	1.35 125 1.30 125 1.25 125 1.01 125	20 30 30 30	2 100 2 100 2 100 4.5 100	175 175 175 175	3.0 2.75 1.6 0.9	X010a
DSEE 8-08CC	2x400	10 130	1.12 125	30	2 100	175	2.75	
DSEE 15-12CC DSEE 29-12CC DSEE 30-12A ①	2x600	15 100 30 90 30 90	1.50 125 1.75 125 1.78 125	35 30 30	4 100 4 100 4 100	175 175 175	1.6 0.9 0.9	X014a
DSEE 55-24N1F	2x1200	55 90	1.50 typ. 125	220 / 125°C	79 / 125°C 750	150	0.63	X024b

① Non isolated base plate

X024b **ISOPLUS i4-PAC™**
Weight = 6 g



X027a **SOT-227B miniBLOC**
Weight = 30 g

Common anode connected

DSEA 16-06AC DSEA 16-06BC DSEA 29-06AC DSEA 59-06BC	600	2x8 120 2x8 110 2x15 130 2x30 105	1.42 150 1.65 150 1.34 150 1.56 150	35 30 35 30	3.5 100 1.4 100 4 100 4 100	175 175 175 175	3 2.5 2.0 1.1	X010a
--	-----	--	--	----------------------	--------------------------------------	--------------------------	------------------------	-------

Data according to IEC 60747 and refer to a single diode or thyristor unless otherwise stated.

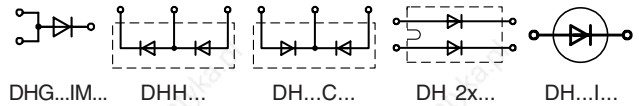
SONIC-FRD™ Diodes



$I_{FAV} = 10 - 120 \text{ A}$

- ultrasoft and fast recovery
- very low temperature dependence

Type	V_{RRM}	I_{FAV}	T_C	@ I_{FSM}	V_F	@ I_F	t_{rr}	I_{RM}	-di/dt	T_{VJM}	R_{thJC}	Fig.	Package style No.	
► New	V	A	°C	45°C	$T_{VJM} = 150^\circ\text{C}$	max. $T_{VJ} = 25^\circ\text{C}$	ns	A	A/ μs	°C	K/W		Outline drawings on page 188 - 224	
► DHG 10I600PA	600	10	95	100	2.20	10	35	4	200	150	1.80	X005b	TO-220 AC Weight = 2 g	
► DHG 10I600PM		10	30	100	2.20	10		4	200		4.00	X007b		
► DHG 20C600QB		2x10	100	100	2.20	10		4	200		1.80	X017a		
► DHG 30I600PA			30	95	200	2.22	30		12		600	0.60		X005b
► DHF 30IM600PN		15	35	200	2.22	30		12	600		3.50	X007a		TO-220ABFP Weight = 2 g
► DHG 30I600HA		30	85	200	2.20	30		12	600		0.70	X014b		
► DHF 30IM600QB		30	85	200	2.20	30		12	600		0.70	X017a		
► DHG 60C600HB	2x30	85	200	2.20	30		12	600	0.70	X014a				
► DHG 30I1200HA	1200	30	85	180	2.40	30	75	25	1000	150	0.70	X014b		
► DH 20-18A	1800	20	80	150	2.94	20	150	16	200	150	0.90	X014b	TO-220ACFP Weight = 2 g	
► DH 40-18A		40	85	350	2.69	40		33	400		0.45	X014b		
► DH 60-18A		60	80	650	2.65	60		50	600		0.30	X014b		
► DHH 55-36N1F		60	80	650	2.65	60		50	600		0.30	X024b		
► DH 2x61-18A		60	25	650	2.61	60		50	600		0.60	X027a		

X027a SOT-227B miniBLOC
Weight = 30 g



X024b ISOPLUS i4-PAC™
Weight = 6 g

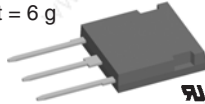

X017a TO-3P
Weight = 5 g

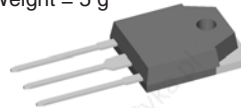

X007b TO-220ACFP
Weight = 2 g

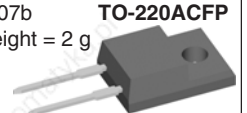

X014a TO-247 AD
Weight = 6 g

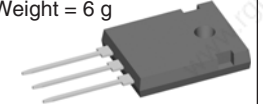

X014b TO-247 AD
Weight = 6 g

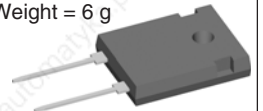

HiPerFRED™ Diodes

$I_{FAV} = 8 - 2x120 \text{ A}$

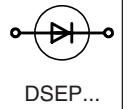

Type	V_{RRM}	I_{FAV}	@ T_C	I_{FSM}	V_F	@ I_F	t_{rr}	I_{RM}	@ -di/dt	T_{VJM}	R_{thJC}	Fig.	Package style	
► New	V	A	°C	10 ms 45°C	max. $T_{VJM} = 150^\circ\text{C}$	$T_{VJ} = 25^\circ\text{C}$	ns	A	A/ μs	°C	K/W		Outline drawings on page 188 - 224	
DSEP 8-02A	200	8	150	80	0.94	8	25	4.1	100	175	2.5	X005b	X004 TO-252AA Weight = 0.3 g	
DSEP 8-03A	300	10	130	60	1.29	10	30	2.4	100	175	2.5	X005b	TO-220 AC Weight = 2 g	
DSEP 8-03AS		8	152	60	1.13	8	30	2.4	100	175	2.5	X004		
DSEP 15-03A		15	135	140	1.21	15	30	2.7	100	175	1.6	X005b		
DSEP 29-03A		30	145	300	0.93	30	30	7.0	100	175	0.9	X005b		
DSEP 30-03A		30	140	300	1.09	30	25	3.5	100	175	0.9	X014b		
► DSEP 30-03AS		30	135	300	1.02	30	35	3.0	200	175	0.85	X011b		
► DSEP 40-03AS		40	120	300	1.11	40	35	3.5	200	175	0.85	X011b		
DSEP 60-03A	60	110	700	1.25	60	30	4.8	100	175	0.65	X014b	X011b TO-263AB Weight = 2 g		
DSEP 30-04A	400	30	140	280	1.11	30	30	6.8	100	175	0.9	X014b	TO-247 AD Weight = 6 g	
DSEP 60-04A		60	120	600	1.01	60	30	7.5	100	175	0.65	X014b		
DSEP 6-06AS	600	6	152	40	1.33	6	20	4.4	100	175	2.8	X004	TO-247 AD Weight = 6 g	
DSEP 8-06A		10	135	50	1.42	10	35	4.4	100	175	2.5	X005b		
DSEP 8-06B		10	125	50	1.66	10	30	2.4	100	175	2.5	X005b		
DSEP 15-06A		15	140	110	1.35	15	35	4.9	100	175	1.6	X005b		
DSEP 15-06B		15	130	110	1.55	15	25	2.6	100	175	1.6	X005b		
DSEP 29-06A		30	135	250	1.26	30	35	6.0	100	175	0.9	X005b		
DSEP 29-06AS		30	135	250	1.26	30	35	6.0	100	175	0.9	X011b		
DSEP 29-06B		30	125	200	1.58	30	30	4.0	100	175	0.9	X005b		
DSEP 30-06A		30	135	250	1.25	30	35	6.0	100	175	0.9	X014b		
DSEP 30-06B		30	125	250	1.56	30	30	4.0	100	175	0.9	X014b		
DSEP 30-06BR		30	115	250	1.56	30	30	4.0	100	175	1.1	X016b		X019 ISOPLUS247™ Weight = 5 g
DSEP 60-06A		60	110	600	1.39	60	35	8.3	100	175	0.65	X014b		
DSEP 60-06AT		60	110	600	1.39	60	35	8.3	100	175	0.65	X019		TO-268 AA Weight = 5 g

HiPerFRED™ Diodes

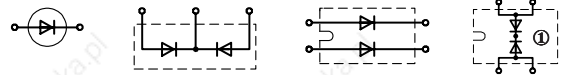

$$I_{FAV} = 8 - 2 \times 120 \text{ A}$$

DSEP...

DSEC...

DSEP 2x...

DSEC

Type	V _{RRM}	I _{FAV} @ T _C d = 0.5		I _{FSM} 10 ms 45°C	V _F @ I _F max. T _{VJM} = 150°C	t _{rr} typ. T _{VJ} = 25°C	I _{RM} @ -di/dt typ. T _{VJ} = 100°C	T _{VJM}	R _{thJC}	Fig. No.	Package style		
► New	V	A	°C	A	V	ns	A	°C	K/W		Outline drawings on page 188 - 224		
DSEP 8-12A	1200	10	115	40	1.96	10	40	4.0	100	175	2.5	X005b	TO-220AB Weight = 2 g
DSEP 12-12A		15	125	90	1.79	15	40	4.5	100	175	1.6	X005b	
► DSEP 12-12B		15	125	90	2.20	15	35	3.7	100	175	1.6	X005b	
DSEP 29-12A		30	115	200	1.81	30	40	8.5	100	175	0.9	X005b	
DSEP 30-12A		30	115	200	1.79	30	40	8.5	100	175	0.9	X014b	
DSEP 30-12AR		30	110	200	1.79	30	40	8.5	100	175	1.1	X016b	
DSEP 60-12A		60	90	500	1.74	60	40	8.5	100	175	0.65	X014b	
DSEP 60-12AR		60	85	500	1.74	60	40	8.5	100	175	0.65	X016b	
DSEC 16-02A	200	2x8	150	80	0.94	8	25	3.5	100	175	2.5	X005a	TO-220 AC Weight = 2 g
DSEC 29-02A		2x15	150	140	0.86	15	25	3.5	100	175	1.6	X005a	
DSEC 29-02AS		2x15	150	140	0.86	15	25	3.5	100	175	1.6	X011b	
DSEC 30-02A		2x15	150	140	0.85	15	25	3.5	100	175	1.6	X014a	
DSEC 60-02A		2x30	145	325	0.95	30	25	4.0	100	175	0.9	X014a	
DSEC 60-02AQ		2x30	145	325	0.95	30	25	4.0	100	175	0.9	X017a	
DSEC 30-03A	300	2x15	140	110	1.20	15	30	2.0	100	175	1.6	X014a	TO-263AB Weight = 2 g
DSEC 60-03A		2x30	145	300	0.91	30	30	4.5	100	175	0.9	X014a	
DSEC 59-03AQ		2x30	125	300	1.00	30	30	3.0	100	175	1.4	X017a	
DSEC 60-03AR		2x30	135	300	0.91	30	30	4.5	100	175	1.1	X016a	
DSEC 16-04AS	400	2x10	140	60	1.12	10	30	2.0	100	175	2.5	X011b	TO-247 AD Weight = 6 g
DSEC 30-04A		2x15	145	tbd	1.06	15	30	5.0	100	175	1.6	X014a	
DSEC 60-04A		2x30	140	tbd	1.09	30	30	5.5	100	175	0.9	X014a	
DSEC 16-06A	600	2x10	135	50	1.42	10	35	3.5	100	175	2.5	X005a	TO-247 AD Weight = 6 g
DSEC 16-06AC		2x8	85	50	1.20	10	35	3.5	100	175	3.0	X010a	
DSEC 16-06BC		2x8	110	50	1.76	8	30	1.4	100	175	2.5	X010a	
DSEC 29-06AC		2x15	140	110	1.34	15	35	4.0	100	175	1.6	X010a	
DSEC 30-06A		2x15	140	110	1.34	15	35	4.0	100	175	1.6	X014a	
DSEC 30-06B		2x15	125	110	1.59	15	25	4.0	100	175	1.6	X014a	
DSEC 59-06BC		2x30	105	200	1.56	30	30	4.0	100	175	1.1	X010a	
DSEC 60-06A		2x30	135	250	1.25	30	35	6.0	100	175	0.9	X014a	
DSEC 60-06B	2x30	125	250	1.56	30	30	4.0	100	175	0.9	X014a		
DSEC 16-12A	1200	2x10	115	40	1.96	10	40	4.0	100	175	2.5	X005a	TO-264 Weight = 10 g
DSEC 30-12A		2x15	125	90	1.78	15	40	4.5	100	175	1.6	X014a	
DSEC 60-12A		2x30	115	200	1.78	30	40	5.5	100	175	0.9	X014a	
DSEC 120-12AK		2x60	90	500	1.74	60	40	7.0	100	175	0.65	X020	
DSEP 2x31-03A	300	2x30	110	300	0.96/125°C	30	30	4.5	100	150	1.15	X027a	ISOPLUS247™ Weight = 5 g
DSEP 2x61-03A		2x60	75	600	1.26	60	30	4.0	100	150	0.85		
DSEP 2x91-03A		2x90	65	1000	1.30	90	30	4.5	100	150	0.6		
DSEP 2x31-04A	400	2x30	105	280	1.15	30	30	5.5	100	150	1.15		
DSEP 2x31-06A	600	2x30	95	250	1.30	30	35	6.0	100	150	1.15		TO-3P Weight = 5 g
DSEP 2x31-06B		2x30	85	250	1.73	30	30	4.0	100	150	1.15		
DSEP 2x61-06A		2x60	65	600	1.48	60	35	6.5	100	150	0.85		
DSEP 2x91-06A		2x90	55	1000	1.52	90	35	6.0	100	150	0.6		
DSEP 2x31-12A	1200	2x30	70	200	1.96	30	40	8.5	100	150	1.15		TO-264 Weight = 10 g
DSEP 2x60-12A		2x60	80	800	1.70	60	40	8.0	100	150	0.6		
DSEP 2x61-12A		2x60	80	800	1.70	60	40	8.0	100	150	0.6		
DSEP 2x101-04A	400	2x101	60	1000	1.24	125	30	5.5	100	150	0.6		
DSEC 240-04A ①	400	2x120	115	2000	1.07	120	30	5.5	100	150	0.2	X027b	
DSEC 240-06A ①	600	2x120	105	2000	1.39	120	35	6.0	100	150	0.2		

① Non isolated base plate

X027a/b **SOT-227B miniBLOC**
Weight = 30 g



HiPerFRED² Diodes

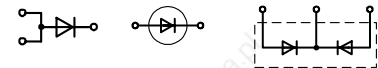

DPG...IM... DPG...I... DPG...C...

$I_{FAV} = 10 - 120 \text{ A}$

Type	V_{RRM}	$I_{FAV} @ T_C$ $d = 0.5$		I_{FSM} 10 ms 45°C	$V_F @ I_F$ max. $T_{VJM} = 150^\circ\text{C}$	t_{rr} typ. $T_{VJ} = 25^\circ\text{C}$	$I_{RM} @ -di/dt$ typ. $T_{VJ} = 25^\circ\text{C}$		T_{VJM}	R_{thJC}	Fig. No.	Package style	
> New	V	A	°C	A	V	ns	A	A/ μs	°C	K/W		Outline drawings on page 188 - 224	
> DPG 10I200PA	200	10	145	100	0.98	10	3	200	175	2.30	X005b	X004 TO-252AA Weight = 0.3 g	
> DPG 10I200PM		10	125	100	0.98	10					X007b		
> DPG 20C200PB		2x10	145	100	0.98	10					X005a		
> DPG 20C200PN		2x10	125	100	0.98	10					X007a		
> DPG 15I200PA		15	140	150	1.00	15					X005b		
> DPG 30C200PB		2x15	140	150	1.00	15					X005a		
> DPG 30C200HB		2x15	140	150	1.00	15					X014a		
> DPG 60C200QB		2x30	135	300	1.06	30					0.95		X017a
> DPG 10I300PA	300	10	140	100	0.98	10	3	200	175	2.30	X005b	X005b TO-220 AC Weight = 2 g	
> DPG 20C300PB		2x10	145	100	0.98	10					X005a		
> DPG 20C300PN		2x10	125	100	0.98	10					X007a		
> DPG 15I300PA		15	140	150	1.00	15					X005b		
> DPG 30C300PB		2x15	140	150	1.00	15					X005a		
> DPG 30C300PC		2x15	140	150	1.00	15					X011b		
> DPG 30C300HB		2x15	140	150	1.00	15					X014a		
> DPG 60C300HB		2x30	135	300	1.06	30					0.95		X014a
> DPG 60C300QB		2x30	135	300	1.06	30					0.95		X017a
> DPG 60IM300PC		60	135	550	1.10	60					0.45		X011b
> DPG 120C300QB		2x60	125	550	1.10	60					0.55		X017a
> DPG 10I400PA		400	10	145	100	1.04					10		4
> DPG 10I400PM	10		120	100	1.04	10	X007b						
> DPG 20C400PB	2x10		145	100	1.04	10	X005a						
> DPG 30C400HB	2x15		140	150	1.07	15	X014a						
> DPG 60C400QB	2x30		135	300	1.13	30	0.95	X017a					
> DPG 60I400HA	60		120	600	1.22	60	0.55	X014b					
> DPG 60IM400QB	60		120	600	1.22	60	0.55	X017a					
												X011b	

FRED Diodes

Fast Recovery Epitaxial Diodes (FRED)

$I_{FAV} = 6 - 120 \text{ A}$

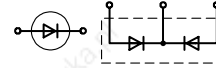

DSEI... DSEK...

Type	V_{RRM}	$I_{FAV} @ T_C$ $d = 0.5$		I_{FRMS}	I_{FSM} 10 ms 45°C	$V_F @ I_F$ max. $T_{VJ} = 150^\circ\text{C}$	t_{rr} typ. $T_{VJ} = 25^\circ\text{C}$	$I_{RM} @ -di/dt$ typ. $T_{VJ} = 100^\circ\text{C}$		R_{thJC}	Fig. No.	Package style
> New	V	A	°C	A	A	V	ns	A	A/ μs	K/W		Outline drawings on page 188 - 224
DSEI 6-06AS	600	6	125	16	65	1.3	8	35	2.5	64	3.0	X004
DSEI 8-06A	600	8	115	16	100	1.3	8	35	2.5	64	2.5	X005b
DSEI 8-06AS	600	8	115	16	100	1.3	8	35	2.5	64	2.5	X011b
DSEI 12-06A	600	14	100	25	100	1.5	16	35	4	100	2.0	X005b
DSEI 12-10A	1000	12	100	25	75	2.1	12	50	6.5	100	1.6	
DSEI 12-12A	1200	11	100	25	75	2.2	12	50	6.5	100	1.6	
DSEI 20-12A	1200	17	85	70	130	1.87	12	40	7	100	1.6	
DSEI 19-06AS	600	20	65	25	100	1.5	16	35	4	100	2.0	X011b
DSEI 36-06AS	600	37	85	70	300	1.4	37	35	10	240	1.0	
DSEI 30-06A	600	37	85	70	300	1.4	37	35	10	240	1.0	X014b
DSEI 30-10A	1000	30	85	70	200	2.0	36	35	16	240	0.9	
DSEI 30-10AR	1000	30	85	70	200	2.0	36	35	16	240	0.9	X016b
DSEI 30-12A	1200	26	85	70	200	2.2	30	40	16	240	0.9	X014b
DSEI 60-02A	200	69	85	98	600	0.88	60	35	8	200	0.75	X014b
DSEI 60-06A	600	60	70	100	550	1.5	70	35	19	480	0.75	
DSEI 60-06AT	600	60	70	100	550	1.5	70	35	19	480	0.75	X019
DSEI 60-10A	1000	60	60	100	500	1.8	60	35	32	480	0.66	
DSEI 60-12A	1200	52	60	100	500	2.0	60	40	32	480	0.66	
DSEI 120-06A	600	126	70	100	600	1.12	70	35	17	200	0.35	X014b
DSEI 120-12A	1200	109	60	100	600	1.55	70	40	25	200	0.35	
DSEK 60-02A	200	2x34	115	50	325	0.85	30	35	4	100	1.0	X014a
DSEK 60-02AR	200	2x34	115	50	325	0.85	30	35	4	100	1.0	X016a
DSEK 60-06A	600	2x30	85	50	300	1.4	37	35	10	240	1.0	X014a
DSEK 60-12A	1200	2x26	85	50	200	2.2	30	40	16	240	0.9	

Fast Recovery Epitaxial Diodes (FRED)

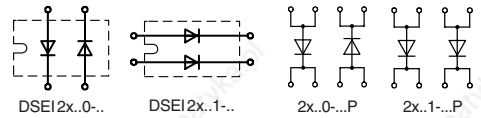



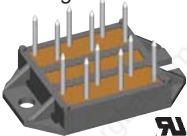



$$I_{FAV} = 2x30 - 2x160 \text{ A}$$

Type	V_{RRM}	$I_{FAV} @ T_C$ $d = 0.5$		I_{FRMS}	I_{FSM} 10 ms	$V_F @ I_F$ max.		t_{rr} typ.	$I_{RM} @ -di/dt$		R_{thJC}	Fig. No.	Package style
$T_{VJM} = 150^\circ\text{C}$ ► New	V	A	$^\circ\text{C}$	A	A	$T_{VJ} = 150^\circ\text{C}$		$T_{VJ} = 25^\circ\text{C}$	$T_{VJ} = 100^\circ\text{C}$		K/W		Outline drawings on page 188 - 224
						V	A	ns	A	A/ μs			
DSEI 2x30-06P	600	2x30	85	70	300	1.4	30	35	10	240	1.25	X101	X027a SOT-227B Weight = 30 g miniBLOC
DSEI 2x30-10P	1000	2x30	50	70	200	2.0	30	35	16	240	1.25		
DSEI 2x30-12P	1200	2x28	50	70	200	2.2	30	40	16	240	1.25		
DSEI 2x30-04C	400	2x30	85	70	300	1.4	30	35	10	240	1.25	X027a	
DSEI 2x30-06C	600	2x30	85	70	300	1.4	30	35	10	240	1.25		
DSEI 2x30-10B	1000	2x30	50	70	200	2.0	30	35	16	240	1.25		
DSEI 2x30-12B	1200	2x28	50	70	200	2.2	30	40	16	240	1.25		
DSEI 2x31-06P	600	2x30	85	70	300	1.4	30	35	10	240	1.25	X101	X101 ECO-PAC 1 Weight = 19 g
DSEI 2x31-10P	1000	2x30	50	70	200	2.0	30	35	16	240	1.25		
DSEI 2x31-12P	1200	2x28	50	70	200	2.2	30	40	16	240	1.25		
DSEI 2x31-04C	400	2x30	85	70	300	1.4	30	35	10	240	1.25	X027a	
DSEI 2x31-06C	600	2x30	85	70	300	1.4	30	35	10	240	1.25		
DSEI 2x31-10B	1000	2x30	50	70	200	2.0	30	35	16	240	1.25		
DSEI 2x31-12B	1200	2x28	50	70	200	2.2	30	40	16	240	1.25		
DSEI 2x61-02P	200	2x71	85	100	950	0.88	60	35	8	200	0.8	X101	See data sheet for pin arrangement
DSEI 2x61-06P	600	2x60	70	100	550	1.50	60	35	19	480	0.7		
DSEI 2x61-10P	1000	2x60	50	100	500	1.80	60	35	32	480	0.7		
DSEI 2x61-12P	1200	2x52	50	100	450	2.15	60	40	32	540	0.7		
DSEI 2x61-02A	200	2x71	85	100	950	0.88	60	35	8	200	0.8	X027a	X102 ECO-PAC 2 Weight = 24 g
DSEI 2x61-04C	400	2x60	70	100	550	1.50	60	35	19	480	0.7		
DSEI 2x61-06C	600	2x60	70	100	550	1.50	60	35	19	480	0.7		
DSEI 2x61-10B	1000	2x60	50	100	500	1.80	60	35	32	480	0.7		
DSEI 2x61-12B	1200	2x52	50	100	450	2.15	60	40	32	480	0.7		
DSEI 2x121-02P	200	2x123	70	150	1200	0.95	120	35	12	200	0.7	X102	See data sheet for pin arrangement
DSEI 2x121-02A	200	2x123	70	150	1200	0.95	120	35	12	200	0.5	X027a	
DSEI 2x101-06P	600	2x96	70	150	1200	1.17	100	40	19	200	0.5	X102	
DSEI 2x101-12P	1200	2x91	50	130	900	1.61	100	40	24	200	0.5		
DSEI 2x101-06A	600	2x96	70	150	1200	1.17	100	35	19	200	0.5	X027a	
DSEI 2x101-12A	1200	2x91	50	130	900	1.61	100	40	24	200	0.5		
DSEI 2x161-02P	200	2x165	70	270	1200	1.05	200	35	20	200	0.29	X102	
DSEI 2x161-06P	600	2x147	70	270	1200	1.40	200	35	45	200	0.29		
DSEI 2x161-12P	1200	2x128	70	270	1200	1.75	200	40	48	200	0.29		

Data according to IEC 60747 and refer to a single diode or thyristor unless otherwise stated.

FRED & HiPerFRED™ Modules

$$I_{FAV} = 75 - 582 \text{ A}$$

Type	V_{RRM}	$I_{FAV} @ T_C$ d = 0.5		I_{FRMS}	I_{FSM} 10 ms 45°C	$V_F @ I_F$ max. $T_{VJ} = 125^\circ\text{C}$		t_{rr} typ. $T_{VJ} = 25^\circ\text{C}$	$I_{RM} @ -di/dt$ max. $T_{VJ} = 100^\circ\text{C}$		R_{thJC}	P_{tot} max.	Fig. No.	Package style
$T_{VJM} = 150^\circ\text{C}$ ► New	V	A	°C	A	A	V	A	ns	A	A/ μs	K/W	W		Outline drawings on page 188 - 224
FRED														
MEO 550-02DA	200	582	75	822	4800	1.08	520	150	15	200	0.071	1750	X126c	X125c Weight = 90 g 
MEO 500-06DA	600	514	75	726		1.41	520	250	132	800		1750		
MEO 450-12DA	1200	453	75	640		1.76	520	450	165	800		1750		
MEK 75-12DA														
MEK 75-12DA	1200	75	75	107	1200	1.85	100	250	33	200	0.45	280*	X125c	
MEA 75-12DA	1200	75	75											
MEE 75-12DA	1200	75	75											
MEK 95-06DA														
MEK 95-06DA	600	95	75	142	1200	1.36	100	250	21	200	0.45	280*	X126a	Weight 150 g 
MEA 95-06DA	600	95	75											
MEE 95-06DA	600	95	75											
MEK 350-02DA														
MEK 350-02DA	200	356	75	503	2400	0.92	260	150	15	200	0.143	875*	X126c	Weight 150 g 
MEK 300-06DA	600	304	75	430		1.19	260	250	66	400		875*		
MEK 250-12DA	1200	260	75	367		1.54	260	450	83	400		875*		
MEE 300-06DA														
MEE 300-06DA	600	304	75	430	2400	1.19	260	250	66	400	0.143	875*	X126c	Weight 150 g 
MEE 250-12DA	1200	260	75	367		1.54	260	450	83	400		875*		
MEA 300-06DA	600	304	75	430	2400	1.19	260	250	66	400	0.143	875*		
MEA 250-12DA														
MEA 250-12DA	1200	260	75	367		1.54	260	450	83	400		875*		
HiPerFRED														
MEK 150-04DA	400	150	100	200	1200	1.4 ^①	300	300	11 typ.	100	0.35	360	X125c	
MEK 600-04DA	400	575	80	800	3000	1.1	400	220	80 typ.	900	0.11	1100	X126a	
► MPK 95-06DA	600	95	110	200	1200	1.4	100	35	5.5	100	0.575	215	X125c	

1 phase and 3 phase rectifiers with fast recovery epitaxial diodes (FRED)

* P_D ^① $T_{VJM} = 150^\circ\text{C}$

Diode connections for Fig. 125 (TO-240)

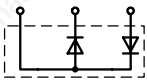

MEE

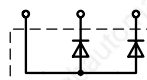

MEA

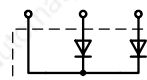

MEK / MPK

Diode connections for Fig. 126 (34 mm package)

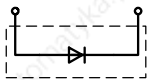

MEO

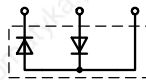

MEE

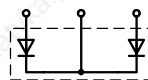

MEK

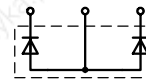





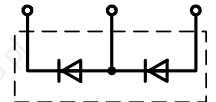
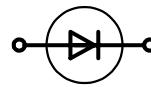





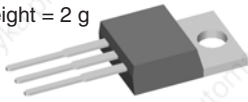
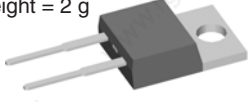
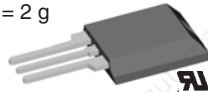

MEA

Rectifier Diodes

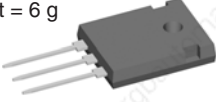
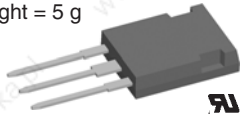

DSP...

$I_{FAV} = 2-45 \text{ A}$, Standard Diodes (DS..), Avalanche Diodes (DSA..)

Type	V_{RRM}	I_{FAV} $T_C = 100^\circ\text{C}$	P_{RSM}	I_{FRMS}	I_{FSM} 45°C 10 ms	V_{T0}	r_T	T_{VJM}	R_{thJC}	R_{thCH}	Fig. No.	Package style
► New	V	A	kW	A	A	V	mΩ	°C	K/W	K/W		Outline drawings on page 188 - 224
DS 1-12 D	1200	2.3	-	7	110	0.8	67	150	$R_{thJA} = 80$		X201	X005a Weight = 2 g 
DSA 1-12 D DSA 1-16 D DSA 1-18 D	1200 1600 1800	$T_{amb} = 45^\circ\text{C}$	1.6	7	110	0.8	67	150	$R_{thJA} = 80$			
DS 2-08 A DS 2-12 A	800 1200											
DSA 2-12 A DSA 2-16 A DSA 2-18 A	1200 1600 1800	$T_{amb} = 45^\circ\text{C}$	2.5	7	120	0.85	43	180	$R_{thJA} = 30$		X200	X005b Weight = 2 g 
DS 2-08 A DS 2-12 A	800 1200											
DSA 2-12 A DSA 2-16 A DSA 2-18 A	1200 1600 1800											
DSP 8-08 S DSP 8-12 S	800 1200	2x11	-	2x17	100	0.8	40	180	3.5	0.6	X011b	X010a Weight = 2 g 
DSP 8-08 A DSP 8-12 A	800 1200	2x11	-	2x17	100	0.8	40	180	3.5	0.6	X005a	
DSP 8-08 AS DSP 8-12 AS	800 1200	2x11	-	2x17	100	0.8	40	180	3.5	0.6	X011a	X010b Weight = 2 g 
DSP 8-12 ACⓄ	1200	2x11	-	2x17	100	0.8	41	150	1.8	0.6	X010a	
DSP 25-12 A DSP 25-16 A	1200 1600	2x28	-	2x43	300	0.8	15	180	1.5	0.4	X014a	X011b Weight = 2 g 
DSP 25-16 ARⓄ	1600	2x28	-	2x43	300	0.8	15	180	1.5	0.4	X016a	
DSP 25-12 AT DSP 25-16 AT	1200 1600	2x28	-	2x43	300	0.8	15	180	1.5	0.4	X019	
DSP 45-12 A DSP 45-16 A	1200 1600	2x45	-	2x70	480	0.8	11	180	0.55	0.2	X014a	X011a Weight = 2 g 
DSP 45-16 AR	1600	$T_C = 130^\circ\text{C}$ 2x43	-	2x70	480	0.8	11	150	0.7	0.2	X016a	
DS 9-08 F DS 9-12 F	800 1200	11	-	18	250	0.85	15	180	2	1	X204	X014a Weight = 6 g 
DSA 9-12 F DSA 9-16 F DSA 9-18 F	1200 1600 1800	11	4.5	18	250	0.85	15	180	2	1		
DS 17-08 A DS 17-12 A	800 1200	25 $T_C = 125^\circ\text{C}$	-	40	370	0.85	8	180	1.5	0.6		
DSA 17-12 A DSA 17-16 A DSA 17-18 A	1200 1600 1800	25 $T_C = 125^\circ\text{C}$	7	40	370	0.85	8	180	1.5	0.6	X205	X016a Weight = 5 g 
DSI 17-08 A DSI 17-12 A	800 1200	25 $T_C = 125^\circ\text{C}$	-	40	370	0.85	8	180	1.5	0.6		
DSAI 17-12 A DSAI 17-16 A DSAI 17-18 A	1200 1600 1800	25	7	40	370	0.85	8	180	1.5	0.6		
DSI 30-08 A DSI 30-12 A DSI 30-16 A	800 1200 1600	30 $T_C = 125^\circ\text{C}$	-	-	300	0.85	13	150	1	0.5	X005b	X200 Weight = 1.5 g 
DSI 30-08 AS DSI 30-12 AS DSI 30-16 AS	800 1200 1600	30	-	-	300	0.85	13	150	1	0.5	X011b	X201 Weight = 0.8 g 
DSI 30-08 ACⓄ DSI 30-12 ACⓄ	800 800	30	-	-	200	0.80	15	150	1.1	0.6		
<p>Ⓞ isolated 2500 V_{RMS}</p>												<p>X204 DO-203AA (DO-4) M5 Weight = 5 g</p> <p>X205 10-32UNF2A Weight = 6 g</p> 

Data according to IEC 60747 and refer to a single diode or thyristor unless otherwise stated.

Rectifier Diodes

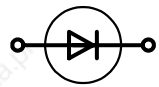
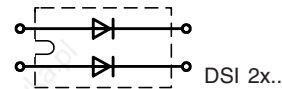
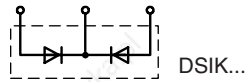

$I_{FAV} = 45-160 \text{ A}$, Standard Diodes (DS..), Avalanche Diodes (DSA..)

Type	V_{RRM}	I_{FAV} $T_C = 100^\circ\text{C}$	P_{RSM}	I_{FRMS}	I_{FSM} 45°C 10 ms	V_{T0}	r_T	T_{VJM}	R_{thJC}	R_{thCH}	Fig. No.	Package style
► New	V	A	kW	A	A	V	mΩ	°C	K/W	K/W		Outline drawings on page 188 - 224
DS 35-08 A DS 35-12 A	800 1200	49	-	80	650	0.85	4.5	180	1.05	0.2	X206a	X010a Weight = 2 g ISOPLUS220™
DSA 35-12 A DSA 35-16 A DSA 35-18 A	1200 1600 1800	49	11	80	650	0.85	4.5	180	1.05	0.2		X010b Weight = 2 g ISOPLUS220™
DSI 35-08 A DSI 35-12 A	800 1200	49	-	80	650	0.85	4.5	180	1.05	0.2	X206a	X010b Weight = 2 g ISOPLUS220™
DSAI 35-12 A DSAI 35-16 A DSAI 35-18 A	1200 1600 1800	49	11	80	650	0.85	4.5	180	1.05	0.2		X014b Weight = 6 g TO-247 AD
DSI 45-08 A DSI 45-12 A DSI 45-16 A	800 1200 1600	48	-	-	475	0.8	8.0	150	0.55	0.2	X010b X010a	X027a Weight = 30 g SOT-227B miniBLOC
DSI 45-16 ARⓄ DSIK 45-16 ARⓄ	1600 1600	45							0.65			
DS 75-08 B DS 75-12 B	800 1200	110	-	160	1400	0.75	2.0	180	0.5	0.4	X207	X027a Weight = 30 g SOT-227B miniBLOC
DSA 75-12 B DSA 75-16 B DSA 75-18 B	1200 1600 1800	110	20	160	1400	0.75	2.0	180	0.5	0.4		
DSI 75-08 B DSI 75-12 B	800 1200	110	-	160	1400	0.75	2.0	180	0.5	0.4	X206a	X207 Weight = 21 g
DSAI 75-12 B DSAI 75-16 B DSAI 75-18 B	1200 1600 1800	110	20	160	1400	0.75	2.0	180	0.5	0.4		
DSI 2x55-12A DSI 2x55-16A	1200 1600	2x56 $T_C = 80^\circ\text{C}$	-	120	650	0.8	8.0	150	0.65	0.1	X027a	X027a Weight = 30 g SOT-227B miniBLOC

Ⓞ isolated 2500 V_{RMS}

Thyristor / Diode Modules

One of the essential advantages of power semiconductor modules compared to discrete designs is the electrical isolation between the baseplate of the module and the parts subject to voltage (3.6 kV_{RMS} tested). This makes possible the mount-down of any number of the same or different modules on a common heatsink. It is feasible to use standard housings with appropriate accessories for designing compact power converter operating from AC mains up to 690 V.

Plastic Housing with DCB Substrate

IXYS has succeeded in simplifying the conventional multilayer module construction by the DCB (Direct Copper Bonding) technique.

Other features are:

- top-side electrical terminals with captured nuts;
- series-connected diode/diode, thyristor/diode and thyristor/thyristor modules;
- easy assembly.

All thyristor modules with DCB ceramic base contacts are available in volume with two standardized twin plugs (2.8 mm x 0.8 mm) for gate and auxiliary cathode control terminals (version 1). Modules in TO-240 housing of the version 8 are delivered with gate plugs only (without auxiliary cathode terminal; mounting screws available on request). The module housing is designed for adequate clearance and creepage distance resulting in  recognition by Underwriters Laboratories, Inc., USA for all types.

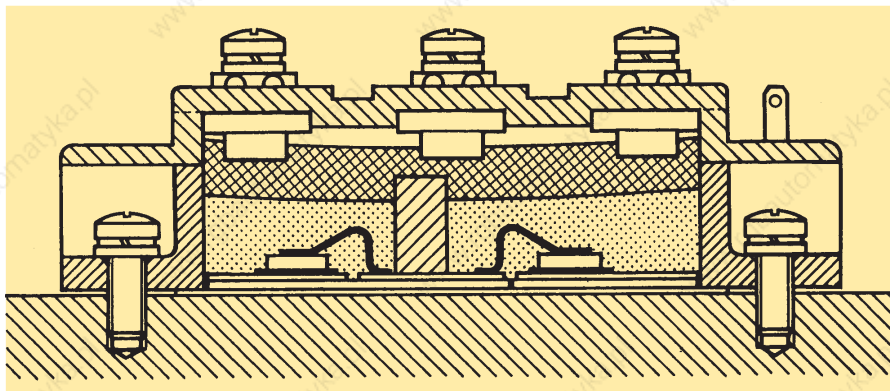

Fig. 2: Principal cross section of an IXYS module with DCB technology

New Generation Silicon Chips

The figures 1 a-c show cross sections of the used thyristor and diode chips in the passivation area. All chips are designed by applying separation diffusion processes such that the zones responsible for the surface field strength are located at the upper chip side. This results in the capability of soldering the entire chip area onto the DCB ceramic substrate without a molybdenum strain buffer, which in turn leads to good stability of the chips as well as to large area heat dissipation if a load is applied. All zones at the edges which are decisive for the blocking stability are coated with passivation glasses the coefficient of expansion of which match that of silicon. Silicon chips increasingly use planar technology with guard rings and channel stoppers to reduce electrical surface fields. This chip design supercedes the design of thyristor chips which were fabricated with passivation moats so that modules of the new series designed with the updated state-of-the-art utilize planar passivated chips processed by separation diffusion techniques. The contact areas of the chips possess physical vapor deposited metal layers. For the user the improved properties are:

- Excellent long-term stability of blocking currents and blocking voltages,
- increased life time of the internal soldered connections,
- high power cycling capability ($\geq 50\,000$).

The thyristor/diode chips have been optimized with regard to their turn-off

parameters: decreasing the carrier lifetime results in reduced stored charges Q_s , which in turn significantly reduces requirements for RC-snubbers for over-voltage protection. Cost reduction and improved efficiency are the benefits of these characteristics. By re-developing the silicon chips, improvements of the firing characteristics were achieved by specifying a higher "gate current not to fire" I_{GD} resulting in substantially less susceptibility to misfiring. This leads to greater safety of operation and higher reliability of the equipment.

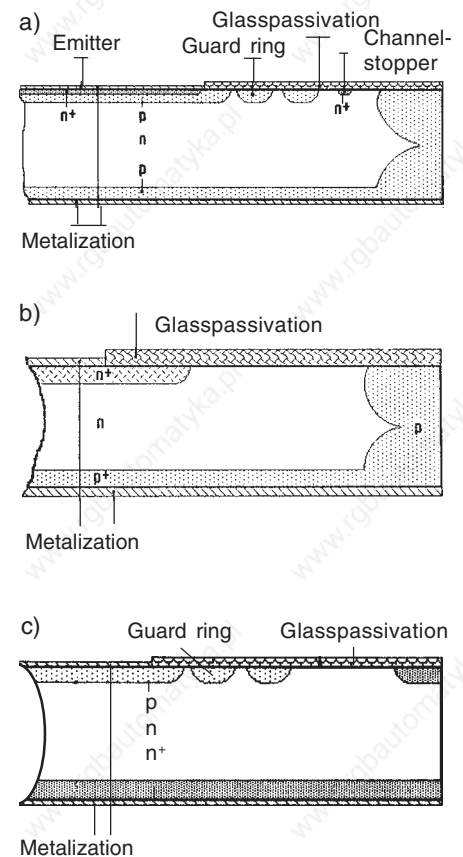

Fig. 1a-c: Cross sections of thyristor and diode chips in the passivation area

- a) glassivated planar thyristor chip with separation diffusion, type CWP
- b) glassivated planar diode chip with separation diffusion, type DWN
- c) glassivated planar diode chip, type DWP (reverse polarity of DWN chips)

Thyristors, SCRs

(SCR = Silicon Controlled Rectifier)

Phase Control Thyristors

Thyristors are very rugged devices. Compared to all other controlled semi-conductor components, they feature the highest current capacity per chip area, especially at high voltage. They are mainly used as control devices in 50 and 60 Hz AC mains equipment.

Principal applications are static converter circuits for speed control of DC-drives, or switching and control functions for temperature, lighting, soft-start, etc. in single-phase and three-phase AC switch configurations. Phase control thyristors are

designed for optimal forward conduction and reverse blocking characteristics, due to only moderate requirements for turn-on and turn-off parameters.

Phase Control Thyristors



$I_{TAV} = 16 - 60 \text{ A}$

Type	V_{RRM} V_{DRM}	I_{TAV} $T_C = 85^\circ\text{C}$	I_{TRMS}	I_{TSM} 45°C 10 ms A	$\left[\frac{dv}{dt}\right]_c$	V_{TO}	r_T	T_{VJM}	R_{thJC}	R_{thCH}	Fig. No.	Package style	
► New	V	A	A	A	V/μs	V	mΩ	°C	K/W	K/W		Outline drawings on page 188 - 224	
CS 8-08 io2 CS 8-12 io2	800 1200	16	25	250	1000	1.0	18	125	1.5	1.0	X208	X005a Weight = 2 g	TO-220AB
CS 19-08 ho1 CS 19-12 ho1	800 1200	19	29	160	500	0.85	27.0	125	1.0	0.25	X005a		
CS 19-08 ho1S CS 19-12 ho1S	800 1200	19	29	160	500	0.85	27.0	125	1.0	0.25	X011b	X007a Weight = 2	TO-220ABFP
CS 19-08 ho1C CS 19-12 ho1C	800 1200	13	35	100	500	0.87	29	125	1.7	0.6	X010a		
CS 20-12 io1 CS 20-14 io1 CS 20-16 io1	1200 1400 1600	19	30	200	1000	1.1	40	125	0.62	0.2	X014a	X010a Weight = 2 g	ISOPLUS220™
CS 20-22 moF1	2200	18		200	2500			125	0.92	0.15	X024c		
CS 22-08 io1M CS 22-12 io1M	800 1200	22	30	300	500	0.9	18	150	2.5	0.5	X007A		
CS 23-08 io2 CS 23-12 io2 CS 23-16 io2	800 1200 1600	25	50	450	1000	1.0	10	125	1.0	0.6	X209	X011b Weight = 2 g	TO-263AB
CS 29-08 io1C CS 29-12 io1C	800 1200	23 $T_C = 95^\circ\text{C}$	35	200	1000	0.82	16.5	150	1.2	0.6	X010a		
CS 30-12 io1 CS 30-14 io1 CS 30-16 io1	1200 1400 1600	31	49	300	1000	0.9	15	125	0.62	0.2	X014a	X014a Weight = 6 g	TO-247 AD
CS 35-08 io4 CS 35-12 io4 CS 35-14 io4	800 1200 1400	63	120	1200	1000	0.85	3.5	125	0.4	0.2	X210		
CS 45-08 io1 CS 45-12 io1 CS 45-16 io1	800 1200 1600	48 $T_C = 75^\circ\text{C}$	75	520	1000	0.85	11	140	0.62	0.2	X014a	X016a Weight = 5 g	ISOPLUS247™
CS 45-16 io1R ①	1600										X016a		
► CLA 50E1200HB ► CLA 50E1200TC	1200	50 $T_C = 125^\circ\text{C}$	75	550	1000	0.92	7.8	150	0.4	0.25	X014a X019		
CS 60-12 io1 CS 60-14 io1 CS 60-16 io1	1200 1400 1600	48 $T_C = 105^\circ\text{C}$	75	1500	1000	0.85	3.7	140	0.32	0.15	X015	X019 Weight = 5 g	TO-268 AA
FCC 21-12 io	1200	21 $T_C = 90^\circ\text{C}$	-	300	1000	-	-	125	1.00	0.32	X024a		

① isolated 2500 V_{RMS}

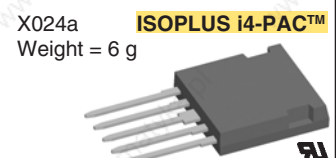
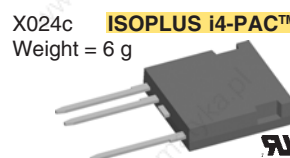
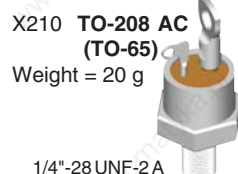
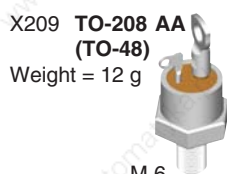

Diode Modules, Single and Dual

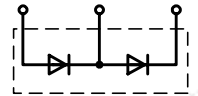

MDD

$$I_{FAV} = 36-224 \text{ A}$$

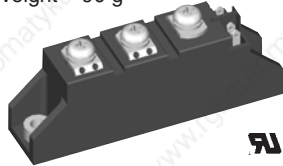
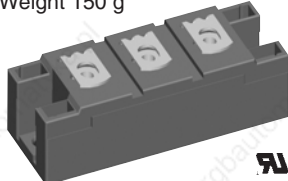
Type	V_{RRM}	$I_{FAV} @ T_C$		I_{FRMS}	I_{FSM} 45°C 10 ms	V_{TO}	r_T	T_{VJM}	R_{thJC} per Chip	R_{thCH} per Chip	Fig. No.	Package style		
►New	V	A	°C	A	A	V	mΩ	°C	K/W	K/W		Outline drawings on page 188 - 224		
MDD 26-08N1B MDD 26-12N1B MDD 26-14N1B MDD 26-16N1B MDD 26-18N1B	800 1200 1400 1600 1800	36	100	60	650	0.8	6.1	150	1.0	0.2	X125b	TO-240 AA Weight = 90 g 		
MDD 44-08N1B MDD 44-12N1B MDD 44-14N1B MDD 44-16N1B MDD 44-18N1B	800 1200 1400 1600 1800	59	100	100	1150	0.8	4.3	150	0.59	0.2				
MDD 56-08N1B MDD 56-12N1B MDD 56-14N1B MDD 56-16N1B MDD 56-18N1B	800 1200 1400 1600 1800	71	100	150	1400	0.8	3.0	150	0.51	0.2				
MDD 72-08N1B MDD 72-12N1B MDD 72-14N1B MDD 72-16N1B MDD 72-18N1B	800 1200 1400 1600 1800	99	100	180	1700	0.8	2.3	150	0.35	0.2				
MDD 95-08N1B MDD 95-12N1B MDD 95-14N1B MDD 95-16N1B MDD 95-18N1B MDD 95-20N1B MDD 95-22N1B	800 1200 1400 1600 1800 2000 2200	120	105	180	2800	0.75	1.95	150	0.26	0.2				
MDD 142-08N1 MDD 142-12N1 MDD 142-14N1 MDD 142-16N1 MDD 142-18N1	800 1200 1400 1600 1800	165	100	300	4700	0.8	1.3	150	0.21	0.1			X126a	X126a Weight 150 g 
MDD 172-08N1 MDD 172-12N1 MDD 172-14N1 MDD 172-16N1 MDD 172-18N1	800 1200 1400 1600 1800	190	100	300	6600	0.8	0.8	150	0.21	0.1				
MDD 200-14N1 MDD 200-16N1 MDD 200-18N1 MDD 200-22N1	1400 1600 1800 2200	224	100	350	10500	0.8	1.5	150	0.13	0.1				

Data according to IEC 60747 and refer to a single diode or thyristor unless otherwise stated.

Diode Modules, Single and Dual

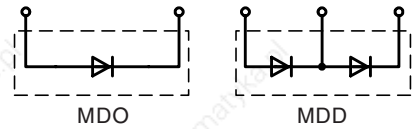

$I_{FAV} = 270-950 \text{ A}$

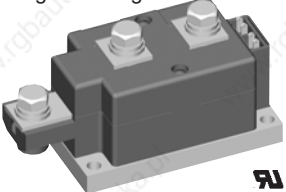
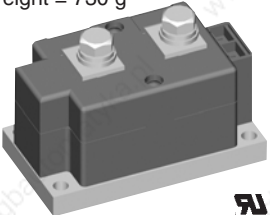
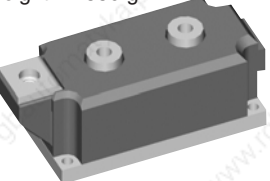
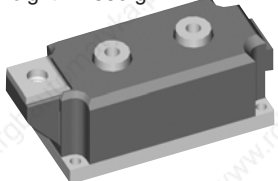
Type	V_{RRM}	I_{FAV}	T_C	I_{FRMS}	I_{FSM} 45°C 10 ms	V_{TO}	r_T	T_{VJM}	R_{thJC} per Chip	R_{thCH} per Chip	Fig. No.	Package style
►New	V	A	°C	A	A	V	mΩ	°C	K/W	K/W		Outline drawings on page 188 - 224
MDD 220-08N1 MDD 220-12N1 MDD 220-14N1 MDD 220-16N1 MDD 220-18N1	800 1200 1400 1600 1800	270	100	450	8500	0.75	0.9	150	0.129	0.04	X129a	X129a Weight = 310 g 
MDD 250-08N1 MDD 250-12N1 MDD 250-14N1 MDD 250-16N1	800 1200 1400 1600	290	100	450	11000	0.75	0.75	150	0.129	0.04		
MDD 255-12N1 MDD 255-14N1 MDD 255-16N1 MDD 255-18N1 MDD 255-20N1 MDD 255-22N1	1200 1400 1600 1800 2000 2200	270	100	450	9500	0.8	0.6	150	0.140	0.04	X131a	X131a Weight = 750 g
MDD 310-08N1 MDD 310-12N1 MDD 310-14N1 MDD 310-16N1 MDD 310-18N1 MDD 310-20N1 MDD 310-22N1	800 1200 1400 1600 1800 2000 2200	305	100	480	11500	0.75	0.63	150	0.129	0.04	X129a	
MDD 312-12N1 MDD 312-14N1 MDD 312-16N1 MDD 312-18N1 MDD 312-20N1 MDD 312-22N1	1200 1400 1600 1800 2000 2200	310	100	520	10500	0.8	0.6	150	0.120	0.04	X131a	X131b Weight = 730 g
MDD 600-12N1* MDD 600-16N1 MDD 600-18N1 MDD 600-22N1	1200 1600 1800 2200	600	111	1818	24000 150°C	0.75	0.2	150	0.062	0.02	X136a	
MDO 500-12N1 MDO 500-14N1 MDO 500-16N1 MDO 500-18N1 MDO 500-20N1 MDO 500-22N1	1200 1400 1600 1800 2000 2200	560	85	880	15000	0.8	0.38	140	0.072	0.024	X131b	
► MDD 950-12N1W* ► MDD 950-16N1W ► MDD 950-18N1W ► MDD 950-22N1W	1200 1600 1800 2200	950	$T_w = 45^\circ\text{C}$	1773	2400 150°C	0.75	0.2	150	$R_{thJW} = 0.09$	-	X136b	X136a Weight = 1550 g 

* for other configurations please contact factory

X136b
Weight = 2100 g

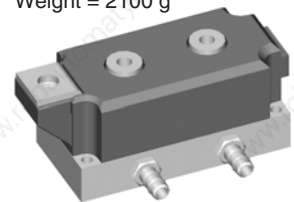

Thyristor / Diode Modules

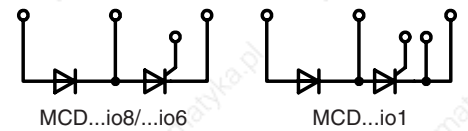

$I_{TAV} = 27-165 \text{ A}$

Type	V_{RRM} V_{DRM}	I_{TAV} @ T_C	I_{TRMS}	I_{TSM} 45°C 10ms	V_{TO}	r_T	T_{VJM}	R_{thJC} per Chip	R_{thCH} per Chip	Fig. No.	Package style
► New	V	A °C	A	A	V	mΩ	°C	K/W	K/W		Outline drawings on page 188 - 224
MCD 26-08io1B MCD 26-12io1B MCD 26-14io1B MCD 26-16io1B	800 1200 1400 1600	27 85	50	520	0.85	11	125	0.88	0.2	X125b	X027a Weight = 30 g SOT-227B miniBLOC 
MCD 26-08io8B MCD 26-12io8B MCD 26-14io8B MCD 26-16io8B	800 1200 1400 1600	27 85	50	520	0.85	11	125	0.88	0.2	X125c	
MCD 40-12io6 MCD 40-16io6	1200 1600	38 85	60	500	0.85	9.5	125	0.6	0.1	X027a	
MCD 44-08io1B MCD 44-12io1B MCD 44-14io1B MCD 44-16io1B MCD 44-18io1B	800 1200 1400 1200 1600	49 85	80	1150	0.85	5.3	125	0.53	0.2	X125b	X125b Weight = 90 g TO-240 AA 
MCD 44-08io8B MCD 44-12io8B MCD 44-14io8B MCD 44-16io8B MCD 44-18io8B	800 1200 1400 1600 1800	49 85	80	1150	0.85	5.3	125	0.53	0.2	X125c	
MCD 56-08io1B MCD 56-12io1B MCD 56-14io1B MCD 56-16io1B MCD 56-18io1B	800 1200 1400 1600 1800	60 85	100	1500	0.85	3.7	125	0.45	0.2	X125b	
MCD 56-08io8B MCD 56-12io8B MCD 56-14io8B MCD 56-16io8B MCD 56-18io8B	800 1200 1400 1600 1800	60 85	100	1500	0.85	3.7	125	0.45	0.2	X125c	X125c Weight = 90 g TO-240 AA 
MCD 72-08io1B MCD 72-12io1B MCD 72-14io1B MCD 72-16io1B MCD 72-18io1B	800 1200 1400 1600 1800	85 85	180	1700	0.85	3.2	125	0.3	0.2	X125b	
MCD 72-08io8B MCD 72-12io8B MCD 72-14io8B MCD 72-16io8B MCD 72-18io8B	800 1200 1400 1600 1800	85 85	180	1700	0.85	3.2	125	0.3	0.2	X125c	
MCD 94-20io1B MCD 94-22io1B	2000 2200	104 85	180	1700	0.85	3.2	125	0.22	0.2	X125b	X126a Weight 150 g 
MCD 95-08io1B MCD 95-12io1B MCD 95-14io1B MCD 95-16io1B MCD 95-18io1B	800 1200 1400 1600 1800	116 85	180	2250	0.8	2.4	125	0.22	0.2	X125b	
MCD 95-08io8B MCD 95-12io8B MCD 95-14io8B MCD 95-16io8B MCD 95-18io8B	800 1200 1400 1600 1800	116 85	180	2250	0.8	2.4	125	0.22	0.2	X125c	
MCD 132-08io1 MCD 132-12io1 MCD 132-14io1 MCD 132-16io1 MCD 132-18io1	800 1200 1400 1600 1800	130 85	300	4750	0.8	1.5	125	0.23	0.1	X126a	X126a Weight 150 g 
MCD 161-20io1 MCD 161-22io1	2000 2200	165 85	300	6000	0.8	1.6	125	0.155	0.07	X126a	

Data according to IEC 60747 and refer to a single diode or thyristor unless otherwise stated.

Thyristor / Diode Modules

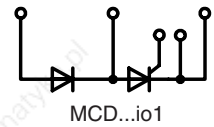

$I_{TAV} = 181 - 700 \text{ A}$

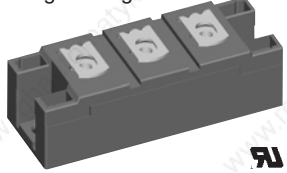
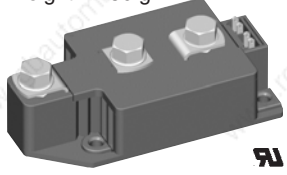
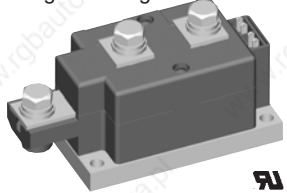
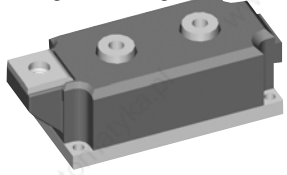
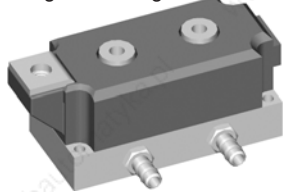
Type	V_{RRM} V_{DRM}	I_{TAV} @ T_C	I_{TRMS}	I_{TSM} 45°C 10 ms	V_{T0}	r_T	T_{VJM}	R_{thJC} per Chip	R_{thCH} per Chip	Fig. No.	Package style	
► New	V	A	°C	A	V	mΩ	°C	K/W	K/W		Outline drawings on page 188 - 224	
MCD 162-08io1 MCD 162-12io1 MCD 162-14io1 MCD 162-16io1 MCD 162-18io1	800 1200 1400 1600 1800	181	85	300	6000	0.88	1.15	125	0.155	0.07	X126a	X126a Weight 150 g 
MCD 200-14io1 MCD 200-16io1 MCD 200-18io1	1400 1600 1800	216	85	340	8000	0.8	1.0	125	0.13	0.05		
MCD 224-20io1 MCD 224-22io1	2000 2200	240	85	400	8000	0.8	0.76	130	0.139	0.04	X131a	
MCD 220-08io1 MCD 220-12io1 MCD 220-14io1 MCD 220-16io1	800 1200 1400 1600	250	85	400	8500	0.9	1.0	140	0.139	0.04	X129b	X129b Weight = 750 g 
MCD 225-12io1 MCD 225-14io1 MCD 225-16io1 MCD 225-18io1	1200 1400 1600 1800	221	85	400	8000	0.8	0.76	130	0.157	0.04	X131a	X131a Weight = 750 g 
MCD 250-08io1 MCD 250-12io1 MCD 250-14io1 MCD 250-16io1 MCD 250-18io1	800 1200 1400 1600 1800	287	85	450	9000	0.85	0.82	140	0.129	0.04	X129b	
MCD 255-12io1 MCD 255-14io1 MCD 255-16io1 MCD 255-18io1	1200 1400 1600 1800	250	85	450	9000	0.8	0.68	130	0.14	0.04	X131a	
MCD 310-08io1 MCD 310-12io1 MCD 310-14io1 MCD 310-16io1 MCD 310-18io1	800 1200 1400 1600 1800	320	85	500	9200	0.8	0.82	140	0.112	0.04	X129b	X136a Weight = 1550 g 
MCD 310-20io1 MCD 310-22io1	2000 2200	320	85	500	8000	0.8	0.82	140	0.112	0.04	X129b	
MCD 312-12io1 MCD 312-14io1 MCD 312-16io1 MCD 312-18io1	1200 1400 1600 1800	320	85	520	9200	0.8	0.68	140	0.12	0.04	X131a	X136b Weight = 2100 g 
MCD 500-12io1* MCD 500-16io1 MCD 500-18io1	1200 1600 1800	500	89	1294	18200 125°C	0.85	0.27	125	0.062	0.02	X136a	
MCD 500-22io1	2200	500	80	1071	15400 125°C	0.88	0.46	125	0.062	0.02	X136b	
MCD 700-12io1W* MCD 700-16io1W MCD 700-18io1W	1200 1600 1800	700	$T_w = 42^\circ\text{C}$	1331	18200 125°C	0.85	0.27	125	0.062	$R_{thJW} = 0.09$	X136b	

* for other configurations please contact factory

Thyristor Modules

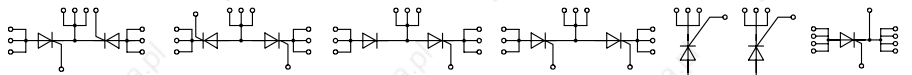

$I_{TAV} = 105 - 180 \text{ A}$

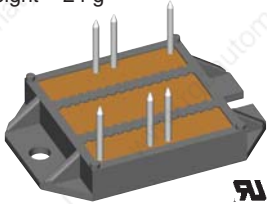
Type	V_{RRM} V_{DRM}	I_{TAV} @ T_C	I_{TRMS}	I_{TSM} 45°C 10 ms	V_{TO}	r_T	T_{VJM}	R_{thJC} per Chip	R_{thCH} per Chip	Fig. No.	Package style	
► New	V	A	°C	A	V	mΩ	°C	K/W	K/W		Outline drawings on page 188 - 224	
VCK 105-06io7 VCK 105-12io7 VCK 105-14io7 VCK 105-16io7 VCK 105-18io7	800 1200 1400 1600 1800	105	85	180	2250	0.8	2.4	125	0.26	0.2	X102	<p>X102 Weight = 24 g</p>  <p>See data sheet for pin arrangement</p>
VCA 105-06io7 VCA 105-12io7 VCA 105-14io7 VCA 105-16io7 VCA 105-18io7	800 1200 1400 1600 1800	105	85	180	2250	0.8	2.4	125	0.26	0.2		
VCD 105-06io7 VCD 105-12io7 VCD 105-14io7 VCD 105-16io7 VCD 105-18io7	800 1200 1400 1600 1800	105	85	180	2250	0.8	2.4	125	0.26	0.2		
VCC 105-06io7 VCC 105-12io7 VCC 105-14io7 VCC 105-16io7 VCC 105-18io7	800 1200 1400 1600 1800	105	85	180	2250	0.8	2.4	125	0.26	0.2		
VCC 2x105-06io7 VCC 2x105-12io7 VCC 2x105-14io7 VCC 2x105-16io7 VCC 2x105-18io7	800 1200 1400 1600 1800	105	85	180	2250	0.8	2.4	125	0.26	0.2		
VCO 132-08io7 VCO 132-12io7 VCO 132-14io7 VCO 132-16io7 VCO 132-18io7	800 1200 1400 1600 1800	130	85	200	3600	0.8	1.65	150	0.25	0.1		
VCO 180-08io7 VCO 180-12io7 VCO 180-14io7 VCO 180-16io7 VCO 180-18io7	800 1200 1400 1600 1800	180	90	280	4500	0.75	1.23	150	0.17	0.06		

Data according to IEC 60747 and refer to a single diode or thyristor unless otherwise stated.

Thyristor Modules

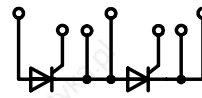

MCC...io1B

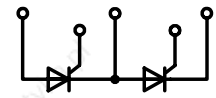

MCC...io8B

$I_{TAV} = 18-116 \text{ A}$

Type	V_{RRM} V_{DRM} V	I_{TAV} @ T_C A °C	I_{TRMS} A	I_{TSM} 45°C 10 ms A	V_{TO} V	r_T mΩ	T_{VJM} °C	R_{thJC} per Chip K/W	R_{thCH} per Chip K/W	Fig. No.	Package style Outline drawings on page 188 - 224
MCC 19-08io1B MCC 19-12io1B MCC 19-14io1B MCC 19-16io1B	800 1200 1400 1600	18 85	40	400	0.85	18	125	1.3	0.2	X125b	 <p>X125b Weight = 90 g</p> <p>TO-240 AA</p>  <p>X125c Weight = 90 g</p> <p>TO-240 AA</p>
MCC 19-08io8B MCC 19-12io8B MCC 19-14io8B MCC 19-16io8B	800 1200 1400 1600	18 85	40	400	0.85	18	125	1.3	0.2	X125c	
MCC 21-08io8B MCC 21-12io8B MCC 21-14io8B MCC 21-16io8B	800 1200 1400 1600	21 85	33	320	0.85	15	125	1.1	0.2	X125c	
MCC 26-08io1B MCC 26-12io1B MCC 26-14io1B MCC 26-16io1B	800 1200 1400 1600	27 85	50	520	0.85	11	125	0.88	0.2	X125b	
MCC 26-08io8B MCC 26-12io8B MCC 26-14io8B MCC 26-16io8B	800 1200 1400 1600	27 85	50	520	0.85	11	125	0.88	0.2	X125c	
MCC 44-08io1B MCC 44-12io1B MCC 44-14io1B MCC 44-16io1B MCC 44-18io1B	800 1200 1400 1600 1800	49 85	80	1150	0.85	5.3	125	0.53	0.2	X125b	
MCC 44-08io8B MCC 44-12io8B MCC 44-14io8B MCC 44-16io8B MCC 44-18io8B	800 1200 1400 1600 1800	49 85	80	1150	0.85	5.3	125	0.53	0.2	X125c	
MCC 56-08io1B MCC 56-12io1B MCC 56-14io1B MCC 56-16io1B MCC 56-18io1B	800 1200 1400 1600 1800	60 85	100	1500	0.85	3.7	125	0.45	0.2	X125b	
MCC 56-08io8B MCC 56-12io8B MCC 56-14io8B MCC 56-16io8B MCC 56-18io8B	800 1200 1400 1600 1800	60 85	100	1500	0.85	3.7	125	0.45	0.2	X125c	
MCC 72-08io1B MCC 72-12io1B MCC 72-14io1B MCC 72-16io1B MCC 72-18io1B	800 1200 1400 1600 1800	85 85	180	1700	0.85	3.2	125	0.3	0.2	X125b	
MCC 72-08io8B MCC 72-12io8B MCC 72-14io8B MCC 72-16io8B MCC 72-18io8B	800 1200 1400 1600 1800	85 85	180	1700	0.85	3.2	125	0.3	0.2	X125c	
MCC 94-20io1B MCC 94-22io1B	2000 2200	104 85	180	1700	0.85	3.2	125	0.22	0.2	X125b	
MCC 95-08io1B MCC 95-12io1B MCC 95-14io1B MCC 95-16io1B MCC 95-18io1B	800 1200 1400 1600 1800	116 85	180	2250	0.8	2.4	125	0.22	0.2	X125b	

Thyristor Modules, Dual

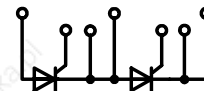

MCC...io1B

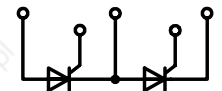

MCC...io8B

$I_{TAV} = 116-700 \text{ A}$

Type	V_{RRM} V_{DRM}	I_{TAV} @ T_C	I_{TRMS}	I_{TSM} 45°C 10 ms	V_{TO}	r_T	T_{VJM}	R_{thJC} per Chip	R_{thCH} per Chip	Fig. No.	Package style
► New	V	A °C	A	A	V	mΩ	°C	K/W	K/W		Outline drawings on page 188 - 224
MCC 95-08io8B MCC 95-12io8B MCC 95-14io8B MCC 95-16io8B MCC 95-18io8B	800 1200 1400 1600 1800	116 85	180	2250	0.8	2.4	125	0.22	0.2	X125c	X125c Weight = 90 g TO-240 AA 
MCC 132-08io1 MCC 132-12io1 MCC 132-14io1 MCC 132-16io1 MCC 132-18io1	800 1200 1400 1600 1800	130 85	300	4750	0.8	1.5	125	0.23	0.1	X126a	X126a Weight 150 g 
MCC 161-20io1 MCC 161-22io1	2000 2200	165 85	300	6000	0.8	1.6	125	0.155	0.07		
MCC 162-08io1 MCC 162-12io1 MCC 162-14io1 MCC 162-16io1 MCC 162-18io1	800 1200 1400 1600 1800	181 85	300	6000	0.88	1.15	125	0.155	0.07		
MCC 170-12io1 MCC 170-14io1 MCC 170-16io1 MCC 170-18io1	1200 1400 1600 1800	203 85	350	5400	0.8	1.0	130	0.164	0.04	X131a	X131a Weight = 750 g 
MCC 200-14io1 MCC 200-16io1 MCC 200-18io1	1400 1600 1800	216 85	340	8000	0.8	1.0	125	0.13	0.05	X126a	X129b Weight = 750 g 
MCC 220-08io1 MCC 220-12io1 MCC 220-14io1 MCC 220-16io1 MCC 220-18io1	800 1200 1400 1600 1800	250 85	400	8500	0.9	1.0	140	0.139	0.04	X129b	X129b Weight = 750 g 
MCC 224-20io1 MCC 224-22io1	2000 2200	240 85	400	8000	0.8	0.76	130	0.139	0.04	X131a	X131a Weight = 750 g 
MCC 225-12io1 MCC 225-14io1 MCC 225-16io1 MCC 225-18io1	1200 1400 1600 1800	221 85	400	8000	0.8	0.76	130	0.157	0.04		
MCC 250-08io1 MCC 250-12io1 MCC 250-14io1 MCC 250-16io1 MCC 250-18io1	800 1200 1400 1600 1800	287 85	450	9000	0.85	0.82	140	0.129	0.04	X129b	X136a Weight = 1550 g 
MCC 255-12io1 MCC 255-14io1 MCC 255-16io1 MCC 255-18io1	1200 1400 1600 1800	250 85	450	9000	0.8	0.68	130	0.14	0.04	X131a	X131a Weight = 2100 g
MCC 310-08io1 MCC 310-12io1 MCC 310-14io1 MCC 310-16io1 MCC 310-18io1	800 1200 1400 1600 1800	320 85	500	9200	0.8	0.82	140	0.112	0.04	X129b	X136a Weight = 1550 g
MCC 312-12io1 MCC 312-14io1 MCC 312-16io1 MCC 312-18io1	1200 1400 1600 1800	320 85	520	9200	0.8	0.68	140	0.12	0.04	X131a	X131a Weight = 2100 g
MCC 500-12io1* MCC 500-14io1 MCC 500-16io1 MCC 500-18io1	1200 1400 1600 1800	500 89	785	18200 125°C	0.85	0.27	125	0.062	0.02	X136a	X136b Weight = 2100 g
MCC 500-22io1*	2200	500 80	1071	15400 125°C	0.88	0.46	125	0.062	0.02		
MCC 700-12io1W MCC 700-16io1W MCC 700-18io1W	1200 1600 1800	700 $T_w = 42°C$	1331	18200 125°C	0.85	0.27	125	0.062	$R_{thJW} = 0.09$	X136b	X136b Weight = 2100 g

* for other configurations please contact factory

Thyristor Modules, Single

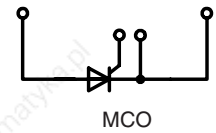

$I_{TAV} = 31-600 \text{ A}$

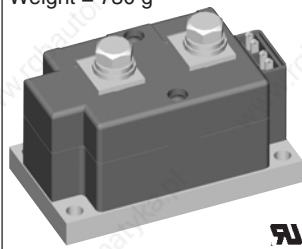
Type	V_{RRM} V_{DRM}	I_{TAV}	T_C	I_{TRMS}	I_{TSM} 45°C 10 ms	V_{TO}	r_T	T_{VJM}	R_{thJC} per Chip	R_{thCH} per Chip	Fig. No.	Package style
► New	V	A	°C	A	A	V	mΩ	°C	K/W	K/W		Outline drawings on page 188 - 224
MCO 25-12io6 MCO 25-16io6	1200 1600	31	80	49	370	0.85	14	150	1.1	0.5	X027a	SOT-227B miniBLOC Weight = 30 g 
MCO 50-12io6 MCO 50-16io6	1200 1600	54	80	85	740	0.9	5.8	150	0.72	0.4		
► MCO 75-12io6 ► MCO 75-16io6	1200 1600	77	80	121	1070	0.85	5.5	150	0.45	0.2		
MCO 100-12io6 MCO 100-16io6	1200 1600	99	80	156	1400	0.85	4.5	150	0.35	0.15		
MCO 150-12io1 MCO 150-16io1	1200 1600	149	80	234	2000	0.8	3.8	150	0.2	0.1		
MCO 450-20io1 MCO 450-22io1	2000 2200	464	85	750	15000	0.77	0.42	130	0.072	0.024	X131b	Weight = 730 g 
MCO 500-12io1 MCO 500-14io1 MCO 500-16io1 MCO 500-18io1	1200 1400 1600 1800	560	85	880	17000	0.8	0.38	140	0.072	0.024		
MCO 600-16io1 MCO 600-18io1 MCO 600-20io1 MCO 600-22io1	1600 1800 2000 2200	600	85	928	15000	0.77	0.42	140	0.065	0.02		

Optional Accessories for Thyristor / Diode Modules

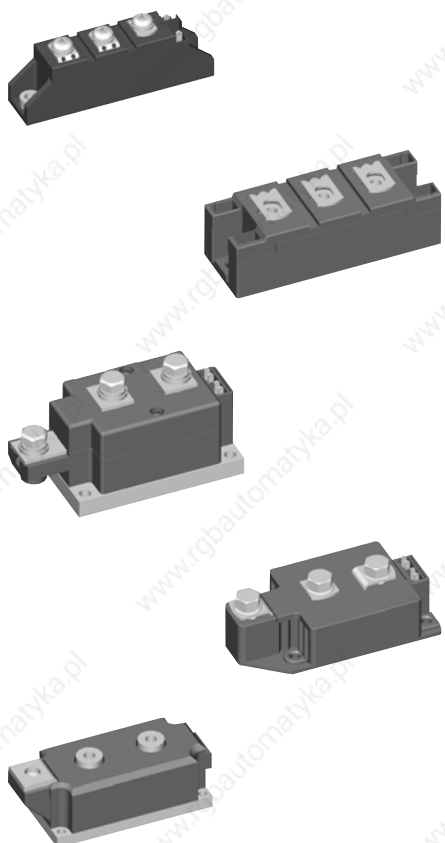

For module-types MCC 19, 26, 44, 56, 60, 72, 94 and 95 version 1:
Keyed Gate Cathode twin plugs with wire length = 350 mm;
gate = yellow, cathode = red
Type **ZY 200 L** (L = Left for pin pair 4/5)
Type **ZY 200 R** (R = Right for pin pair 6/7)

For ZY 180 and ZY 200: UL Styles 1385

For module types MCC/MCD/MCO 122, 132, 161, 162, 170, 200, 220, 224, 225, 250, 255, 310, 312, 500 and MII 400 (for MCD/MCO only L-type):
Keyed Gate Cathode twin plugs with wire length = 350 mm
gate = yellow, cathode = red
Type **ZY 180 L** (L = Left for pin pair 4/5)
Type **ZY 180 R** (R = Right for pin pair 6/7)

For module types MCC/MCD/MDD 220, 250, 310
Threaded spacer for higher Anode / Cathode construction:
Type **ZY 250** (material brass)

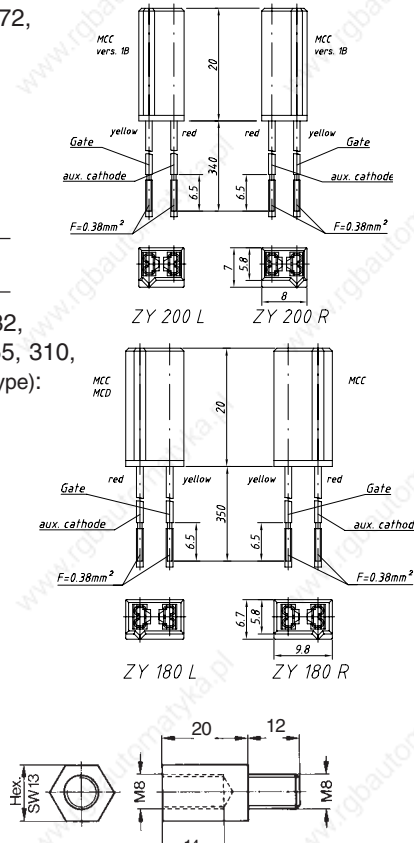

Design Information

For Thyristors, Diodes, Thyristor / Diode Modules and Rectifier Bridges



Surge current	The 60 Hz value of I_{TSM} is 10 % higher than the 50 Hz value The I_{TSM} value at T_{VJM} is 10 to 15 % lower than the 45°C value
Limiting I^2t	50 Hz: I^2t (in A ² s) = $I_{TSM} (A) \cdot I_{TSM} (A) \cdot 0.005 (s)$; use rated I_{TSM} value (10 ms) 60 Hz: I^2t (in A ² s) = $I_{TSM} (A) \cdot I_{TSM} (A) \cdot 0.0042 (s)$; use 60-Hz-value of I_{TSM}
Forward current	The average current ratings in tables are mostly specified for temperature conditions of: $T_A = 45^\circ C$, $T_C = 85^\circ C$ or $T_C = 100^\circ C$. For other temperature conditions, the current ratings can be calculated using the following formulas, applicable up to 400 Hz.
$I_{TAV} = \frac{-V_{TO} + \sqrt{V_{TO}^2 + 4 \cdot k^2 \cdot r_T \cdot P}}{2 \cdot k^2 \cdot r_T} \quad \text{where} \quad P = \frac{T_{VJM} - T_C}{R_{thJC}} \quad \text{or} \quad P = \frac{T_{VJM} - T_A}{R_{thJA}}$	
I_{TAV} (A), P (W); V_{TO} (V); r_T (Ω), T_{VJM} ($^\circ C$), T_C ($^\circ C$), T_A ($^\circ C$) R_{thJC} (K/W), R_{thJA} (K/W)	
$k^2 = 1$ for DC current $k^2 = 2.5$ for sinusoidal half wave current $k^2 = 3.0$ for 120° rectangular current $k^2 = 6.0$ for 60° rectangular current	
The average forward current is limited by the RMS current value I_{TRMS} . When the calculated value I_{TAV} is higher than I_{TRMS}/k , replace it by $I_{TAV} = I_{TRMS}/k$.	

Rectifier Bridges for Power Factor Correction

Power Stage for Boost Converters (Power Factor Correction)

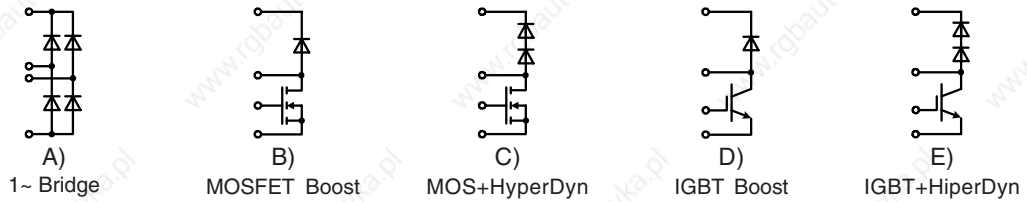
1-phase PFC

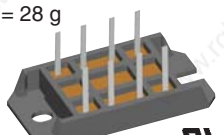

Type	Circuit	V_{DSSmax} V	I_D $T_c = 25^\circ C$ A	$R_{DS(on)}$ max. Ω	V_{RRM} BoostDiode V	V_{RRM} Rectifier Diodes V	Fig. No.	Package style Outline drawings on page 188 - 224
MOSFET	► IXFN 64N50PD2	B	52	0.086	600	-	X027a	X024a ISOPLUS i4-PAC™ Weight = 6 g 
	FMD 21-05QC	C	21	0.22	600	-	X024a	
	FMD 25-06KC5	C, CoolMOS**	25	0.10	600	-	X024a	
	FMD 25-06KCSiC	C, CoolMOS**	25	0.10	600	-	X024a	
	FMD 40-06KC	C, CoolMOS**	38	0.07	600	-	X024a	
	FMD 40-06KC5	C, CoolMOS**	47	0.045	600	-	X024a	
	VUM 24-05N	A + B	35	0.12	600	800	X105b	
VUM 33-05N	A + B	47	0.12	600	800	X105b		
								X027a SOT-227B miniBLOC Weight = 30 g 
Type	Circuit	V_{CESmax} V	I_C $T_c = 25^\circ C$ A	$V_{CE(sat)}$ @ I_C V A	V_{RRM} BoostDiode V	V_{RRM} Rectifier Diodes V	Fig. No.	
IGBT	FID 35-06C	E	38	1.9 25	600	-	X024a	X101 ECO-PAC 1 Weight = 19 g  See data sheet for pin arrangement
	FID 36-06D	D	38	1.9 25	600	-	X024a	
	FID 60-06D	D	65	1.6 30	600	-	X024a	
	VUI 9-06N7	A + D	37	1.8 10	600	1200	X101	
								X105b Weight = 28 g 
Type	Circuit	V_{RRM} V	$I_{D(AV)}$ @ T_c					
Rect.	FBO 16-12N *	A	1200		22 A @ 90 °C			X024a
	FBO 40-12N *	A	1200		40 A @ 90 °C			X024a

* Recommended in combination with types FMD and FID

** **COOLMOS™**
Power Semiconductors

CoolMOS™ is a trademark of Infineon Technologies

3-phase PFC

“Vienna Rectifier” circuit

- wide input voltage range
- sinusoidal mains input currents in phase with mains
- boost converter operation:
 - input: three phase AC mains without neutral conductor
 - output: stabilized DC link with center point
- one module used per phase

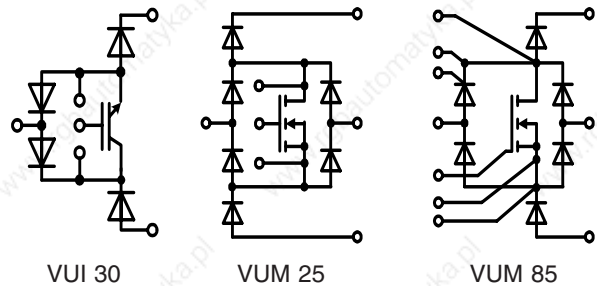

For further information on this circuit please visit IXYS website <http://www.ixys.com>

Type	P_N / kW 3 ~ 400 V $T_c = 80^\circ C$	Configuration	Fig. No.	Package style Outline drawings on pages 188 - 224
VUM 25-05E	10	Vienna rectifier current	X103	X103 Weight = 35 g 
VUM 85-05A	30	Vienna rectifier current	X104	
VUI 30-12N1	15	IGBT stage for buck @ boost PWM converter	X103	

MOS / IGBT AC switch

- Fast AC switch
- Easy to turn-off like a MOSFET or IGBT
- Applications
 - lighting control
 - AC motor control
 - matrix inverter

Type	Configuration	BV voltage ±	Rated current A $T_c = 25\text{ }^\circ\text{C}$	Circuit	Fig. No.	Package style Outline drawings on page 188 - 224
► New						
VMK 165-007T	MOSFET in common source	70	165	A	X125b	X005a TO-220AB Weight = 2 g
FMK 75-01F	MOSFET in common source	100	75	B	X024a	X014a TO-247 AD Weight = 6 g
VMK 90-02T2	MOSFET in common source	200	83	A	X125b	
► IXRP 15N120	single RIGBT ①	1200	25	D	X005a	
IXRH 40N120	single RIGBT ①	1200	55	D	X014a	
► IXRR 40N120	single RIGBT ①	1200	45	D	X016a	
FIO 50-12BD	IGBT and Diode Bridge	1200	50	C	X024a	

preliminary data, typical values

① Single IGBT die with reverse blocking capability

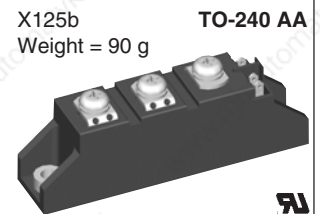
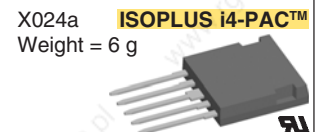
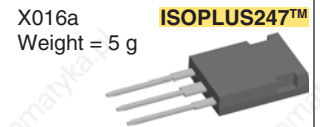
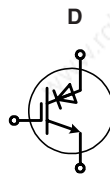
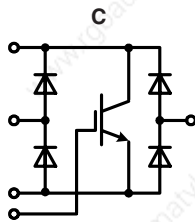
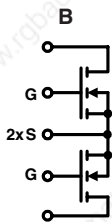
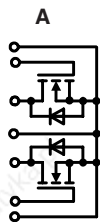

Module with HiPerFET™ H-Bridge and Single Phase Mains Rectifier Bridge

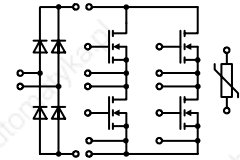

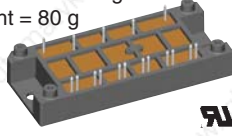
Type	V_{DSS} V	I_D A $T_c = 25^\circ\text{C}$	I_D A $T_c = 80^\circ\text{C}$	$R_{Dson(max)}$ $m\Omega$ $T_c = 25^\circ\text{C}$	V_{DRM} V rectifier diode	I_{DAVM} A @ T_c	Package style
► New							Outline drawings on page 188 - 224
VBH 40-05B	500	40	30	116	1200	33 80	X104 V2-Package Weight = 80 g 

3~ Rectifier Bridges

with IGBT and Diode for Brake Unit

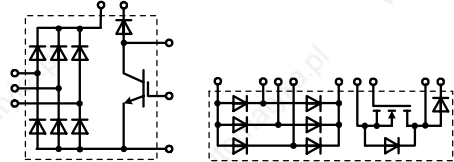

VUB...

VUBM...

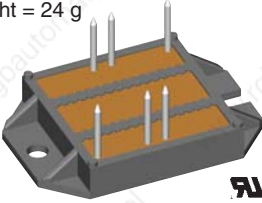
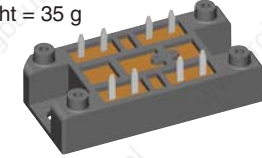
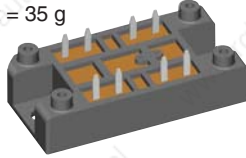
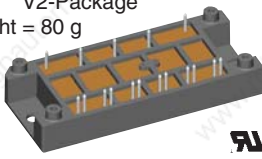
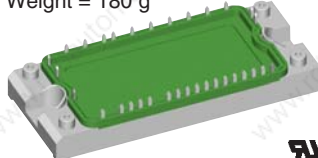
Type	V_{RRM} V	Rectifier		IGBT		fast Diode			Fig. No.	Package style
		I_{dAV} @ T_c A	$^\circ\text{C}$	V_{CES} V	$I_{C 80}$ A	V_{RRM} V	$I_{F(AV)}$ A	t_{rr} ns		
VUB 33-06P1	600	22	90	600	33	600	24	30	X102	X102 Weight = 24 g 
VUBM 33-05P1	500	48	100	500	36/MOSFET	600	30	30	X102	
VUB 50-12PO1	1200	56	100	1200	14	1200	10	110	X102	See data sheet for pin arrangement 
VUB 50-16PO1	1600									
VUB 72-12NO1	1200	110	80	1200	35	1200	15	130	X103	X103 Weight = 35 g 
VUB 72-16NO1	1600									
VUB 116-16NO1	1600	116	100	1200	67	1200	27	40	X112	X104 Weight = 80 g 
VUB 120-12NO2	1200	188	80	1200	100	1200	34	40	X104	
VUB 120-16NO2	1600									
► VUB 135-22NO1	2200	135	100	1700	50	1800	50	40	X112	X112 Weight = 180 g 
VUB 145-16NO1	1600	145	100	1200	100	1200	27	40	X104	
VUB 160-12NO2	1200	188	80	1200	125	1200	34	40	X104	
VUB 160-16NO2	1600									

3~ Half Controlled Rectifier Bridges

with IGBT and Diode for Brake Unit

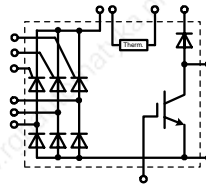

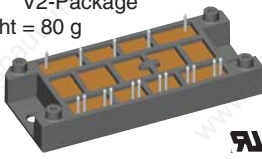
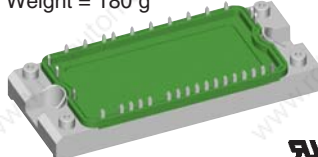
Type	V_{RRM} V	Rectifier		IGBT		fast Diode			Fig. No.	Package style
		I_{dAV} @ T_c A	$^\circ\text{C}$	V_{CES} V	$I_{C 80}$ A	V_{RRM} V	$I_{F(AV)}$ A	t_{rr} ns		
VVZB 120-12io2	1200	120	80	1200	100	1200	27	40	X104	X104 V2-Package Weight = 80 g 
VVZB 120-16io2	1600									
VVZB 135-16NO1	1600	135	85	1200	67	1200	27	40	X112	X112 Weight = 180 g 
VVZB 170-16NO1	1600	170	85	1200	100	1200	27	40	X112	

Rectifier Bridges with Fast Diodes

Rectifier Bridges with Superfast Recovery Diodes

1-phase, B2U

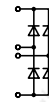

Type	V _{RRM}	I _{dAV} @ T _C	I _{FSM} 45°C 10 ms	V _{T0}	r _T	T _{VJM}	R _{thJC}	R _{thCHtyp} per Chip	Fig. No.	Package style	
► New	V	A	°C	A	V	mΩ	°C	K/W	K/W		Outline drawings on page 188 - 224
VBE 17-06NO7	600	27	85	50	1.18	22.0	150	2.5	0.3	X101	X024a Weight = 6 g
VBE 17-12NO7	1200	19	85	40	1.32	30.0	150	2.5	0.3		
VBE 20-20NO1	2000	20	65	75	3.30	93.0	150	1.7	0.3	X103	X027a Weight = 30 g
VBE 26-06NO7	600	44	85	110	1.13	13.0	150	1.6	0.3	X101	
VBE 26-12NO7	1200	32	85	90	1.32	30.0	150	1.6	0.3		
VBE 55-06NO7	600	68	100	250	0.98	8.0	150	0.9	0.3	X027a	SOT-227B miniBLOC
VBE 55-12NO7	1200	59	85	200	1.31	15.0	150	0.9	0.3		
VBE 60-06A	600	60	90	250	0.98	6.8	150	1.15	0.1	X027a	
FBE 22-06N1	600	20	90	40	-	-	150	3.5	0.15	X024a	X024a Weight = 30 g
VBE 100-06NO7	600	100	85	600	1.09	4.3	150	0.8	0.2	X102	
VBE 100-12NO7	1200	100	70	500	1.07	8.2	150	0.8	0.2		
FBS 10-06SC*	600	6.6	90	12	-	-	175	8.0	3.5	X024a	X024a
FBS 16-06SC*	600	11	90	20	-	-	175	5.6	3.0		

* SiC-Diodes

3-phase, B6U



FUS 45-0045B	45	20	90	150	-	-	150	3.1	0.15	X024a	X101 Weight = 19 g
VUE 50-12NO1	1200	50	85	200	1.65	18.2	150	1.2	0.3	X103	
VUE 30-20NO1	2000	30	65	75	3.30	93.0	150	1.7	0.3		X101
VUE 22-06NO7	600	34	85	50	1.18	22.0	150	2.50	0.3		
VUE 22-12NO7	1200	24	85	40	1.39	55.0	150	2.50	0.3		
VUE 35-06NO7	600	56	85	110	1.13	13.0	150	1.60	0.3	X102	X102 Weight = 24 g
VUE 35-12NO7	1200	40	85	90	1.32	30.0	150	1.60	0.3		
VUE 75-06NO7	600	86	100	250	0.98	8.0	150	0.90	0.3	X102	X102 Weight = 24 g
VUE 75-12NO7	1200	74	85	200	1.31	15.0	150	0.90	0.3		
FUE 30-12N1	1200	30	90	80	-	-	150	2.3	0.15	X024a	X102
VUE 130-06NO7	600	130	85	600	1.09	4.3	150	0.8	0.2	X102	
VUE 130-12NO7	1200	130	70	500	1.07	8.2	150	0.8	0.2		

Rectifier Bridges with Semifast Diodes

3-phase, B6U, t_{rr} = 1.5 μs



VUO 18-12DT8*	1200	18	63	300	1.2	16	150	9.3	0.9	X116b	X116b Weight = 22 g
VUO 18-14DT8*	1400										
VUO 18-16DT8*	1600										

* not recommended for new design

Rectifier Bridges incorporating Fast Diodes

Power switching semiconductors are used in inverter systems with DC-Link. Due to high switching frequencies, harmonics and line distortion may be generated. It is important that the new designs reduce these influences and fulfill the EMI filtering requirements according to EMI/EMC VDE 0871 and other.

The noise level can be reduced by up to **10dB** when the input rectifier is equipped with Semi-fast diodes and is therefore optimised for turn off; resulting in a lower peak recovery current compared to non-optimised and normal rectifier diodes.

The noise level can be further reduced approximately by another **5dB** when using rectifier bridges equipped with Fast

Recovery Epitaxial Diodes (FRED) like module types VBE (single phase bridge) or VUE (three phase bridge). However these are more expensive but may be necessary in some applications to fulfill the VDE or other standards.

This behaviour has a direct influence on the design of the EMI filter networks with its capacitors and inductors of which the size and costs can be reduced.

More detailed information is available in the IXYS application note D98005E "Input Rectifiers with Semi-fast Diodes for DC Link" on www.ixys.com.

1~ Rectifier Bridges

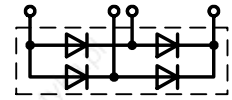

1~ Rectifier Bridges with Avalanche Diodes, B2U

Type	V _{RRM}	V _{VRMS}	I _{dAV} @ T _C		I _{FSM} 45°C 10 ms	V _{TO}	r _T	T _{VJM}	R _{thJC} R _{thJH} per Chip		P _{RSM}	Fig. No.	Package style
► New	V	V	A	°C	A	V	mΩ	°C	K/W	K/W	kW		Outline drawings on page 188 - 224
VBO 13-12AO2	1200	400	18	85	220	0.85	17	150	5.6	6.0	2.5	X115	X024a ISOPLUS i4-PAC™ Weight = 6 g
VBO 13-14AO2	1400	500											
VBO 13-16AO2	1600	500											
VBO 20-12AO2	1200	400	31	85	300	0.85	14	150	3.0	3.4	3.4	X025 Weight = 7 g	
VBO 20-14AO2	1400	440											
VBO 20-16AO2	1600	500											
VBO 25-12AO2	1200	400	38	85	370	0.85	8	150	2.8	3.2	3.4		
VBO 25-14AO2	1400	440											
VBO 25-16AO2	1600	500											



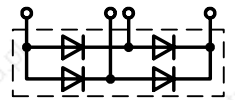

1~ Rectifier Bridges with Standard Diodes, B2U

VBO 13-08NO2	800	250	18	85	220	0.85	17	150	5.6	6.0	-	X115	X027a SOT-227B Weight = 30 g miniBLOC	
VBO 13-12NO2	1200	400												
VBO 13-14NO2	1200	400												
VBO 13-16NO2	1600	500												
FBO 16-12N	1200	400	22	90	100	0.83	28	150	4.0	5.0	-	X024a		
VBO 19-08NO7	800	250	21	100	100	0.8	40	150	2.3	2.8	-	X100	X100 Weight = 17 g Slim-PAC	
VBO 19-12NO7	1200	400												
VBO 20-08NO2	800	250	31	85	300	0.85	14	150	3.0	3.4	-	X115		
VBO 20-12NO2	1200	400												
VBO 20-14NO2	1400	440												
VBO 20-16NO2	1600	500												
VBO 21-08NO7	800	250	21	100	100	0.8	40	150	2.3	2.8	-	X101	X101 Weight = 19 g ECO-PAC 1	
VBO 21-12NO7	1200	400												
VBO 22-08NO8	800	250	17	85	380	0.85	12	150	8.2	9.4	-	X116b	See data sheet for pin arrangement	
VBO 22-12NO8	1200	400												
VBO 22-14NO8	1400	440												
VBO 22-16NO8	1600	500												
VBO 22-18NO8	1800	575												
GBO 25-12NO1	1200	400	25	80	370	0.89	12.2	150	4.3	4.8	-	X025		
VBO 25-08NO2	800	250	38	85	370	0.85	8	150	2.8	3.2	-	X115	See data sheet for pin arrangement	
VBO 25-12NO2	1200	400												
VBO 25-14NO2	1400	440												
VBO 25-16NO2	1600	500												
VBO 30-08NO7	800	250	35	85	400	0.85	12	150	2.8	3.4	-	X119	Weight = 15 g	
VBO 30-12NO7	1200	400												
VBO 30-14NO7	1400	440												
VBO 30-16NO7	1600	500												
VBO 30-18NO7	1800	575												
VBO 36-08NO8	800	250	23	85	550	0.8	5.8	150	6.2	7.4	-	X116b	Weight = 22 g	
VBO 36-12NO8	1200	400												
VBO 36-14NO8	1400	440												
VBO 36-16NO8	1600	500												
VBO 36-18NO8	1800	575												
FBO 40-12N	1200	400	40	90	250	0.83	10	150	2.3	2.9	-	X024a		
VBO 40-08NO6	800	250	40	100	300	0.8	13	150	1.7	2.0	-	X027a	Weight = 100 g	
VBO 40-12NO6	1200	400												
VBO 40-16NO6	1600	500												
VBO 45-08NO7	800	250	45	100	550	0.8	8	150	1.45	1.9	-	X118a	Weight = 135 g	
VBO 45-12NO7	1200	400												
VBO 45-14NO7	1400	440												
VBO 45-16NO7	1600	500												
VBO 45-18NO7	1800	575												

1~ Rectifier Bridges

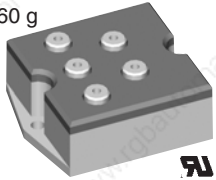
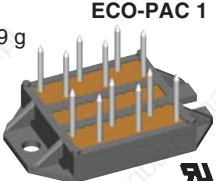
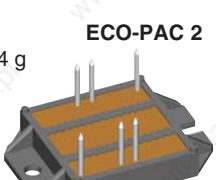
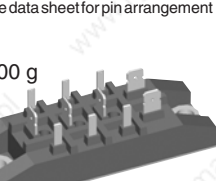
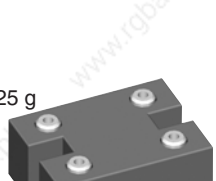

1~ Rectifier Bridges with Standard Diodes, B2U







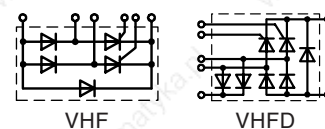

Type	V _{RRM}	V _{VRMS}	I _{dAV}	@ T _C	I _{FSM} 45°C 10 ms	V _{TO}	r _T	T _{VJM}	R _{thJC}	R _{thJH}	Fig. No.	Package style
► New	V	V	A	°C	A	V	mΩ	°C	K/W	K/W		Outline drawings on page 188 - 224
VBO 50-08NO7 VBO 50-12NO7 VBO 50-14NO7 VBO 50-16NO7 VBO 50-18NO7	800 1200 1400 1600 1800	250 400 440 500 575	50	64	750	0.85	8	150	2.6	2.84	X119	Fig. 51 Weight = 260 g 
VBO 52-08NO7 VBO 52-12NO7 VBO 52-14NO7 VBO 52-16NO7 VBO 52-18NO7	800 1200 1400 1600 1800	250 400 440 500 575	52	100	550	0.8	8	150	1.45	1.87	X122	
VBO 54-08NO7 VBO 54-12NO7 VBO 54-14NO7 VBO 54-16NO7	800 1200 1400 1600	250 400 440 500	54	100	300	0.8	13	150	1.1	1.6	X101	X101 Weight = 19 g ECO-PAC 1 
VBO 55-08NO7 VBO 55-12NO7 VBO 55-14NO7 VBO 55-16NO7 VBO 55-18NO7	800 1200 1400 1600 1800	250 400 440 500 575	55	100	750	0.8	6	150	1.3	1.6	X118a	 See datasheet for pin arrangement
VBO 65-08NO7 VBO 65-12NO7 VBO 65-14NO7 VBO 65-16NO7 VBO 65-18NO7	800 1200 1400 1600 1800	250 400 440 500 575	65	100	1000	0.8	5	150	1.12	1.5	X118a	X102 Weight = 24 g ECO-PAC 2 
VBO 68-08NO7 VBO 68-12NO7 VBO 68-14NO7 VBO 68-16NO7	800 1200 1400 1600	250 400 440 500	68	90	530	0.8	7.5	150	1.2	1.5	X101	 See datasheet for pin arrangement
VBO 72-08NO7 VBO 72-12NO7 VBO 72-14NO7 VBO 72-16NO7 VBO 72-18NO7	800 1200 1400 1600 1800	250 400 440 500 575	72	100	750	0.8	5	150	1.1	1.52	X122	X118a Weight = 100 g 
VBO 78-08NO7 VBO 78-12NO7 VBO 78-14NO7 VBO 78-16NO7 VBO 78-18NO7	800 1200 1400 1600 1800	250 400 440 500 575	78	100	750	0.8	6	150	1.2	1.5	X102	
VBO 88-08NO7 VBO 88-12NO7 VBO 88-14NO7 VBO 88-16NO7 VBO 88-18NO7	800 1200 1400 1600 1800	250 400 440 500 575	92	100	900	0.8	4	150	0.85	1.15	X102	X121 Weight = 225 g 
VBO 105-08NO7 VBO 105-12NO7 VBO 105-14NO7 VBO 105-16NO7 VBO 105-18NO7	800 1200 1400 1600 1800	250 400 440 500 575	107	85	1500	0.8	5	150	0.83	1.13	X121	
VBO 125-08NO7 VBO 125-12NO7 VBO 125-14NO7 VBO 125-16NO7 VBO 125-18NO7	800 1200 1400 1600 1800	250 400 440 500 575	124	85	1800	0.8	3	150	0.83	1.13	X121	X122 Weight = 160 g
VBO 130-08NO7 VBO 130-12NO7 VBO 130-14NO7 VBO 130-16NO7 VBO 130-18NO7	800 1200 1400 1600 1800	250 400 440 500 575	122	100	1800	0.8	3	150	0.65	0.83	X123a	X123a Weight = 300 g
VBO 160-08NO7 VBO 160-12NO7 VBO 160-14NO7 VBO 160-16NO7 VBO 160-18NO7	800 1200 1400 1600 1800	250 400 440 500 575	174	100	2800	0.8	2.2	150	0.45	0.6	X123a	

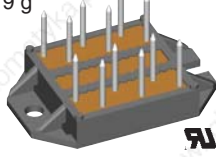
Data according to IEC 60747 and refer to a single diode or thyristor unless otherwise stated.

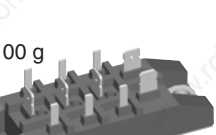
1~ Rectifier Bridges

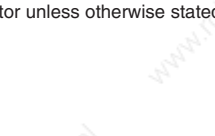

1~ Half Controlled Rectifier Bridges with free wheeling diode, B2HKF

Type	V_{RRM}	V_{VRMS}	$I_{dAV} @ T_H$		I_{FSM} 45°C	V_{TO}	r_T	T_{VJM}	R_{thJC}	R_{thJH}	Fig. No.	Package style Outline drawings on page 188 - 224	
	V	V	A	°C									A
VHF 15-08io5	800	250	15	85	190	1.0	40	125	2.4	3.0	X117a	ECO-PAC 1 Weight = 19 g 	
VHF 15-12io5	1200	400											
VHF 15-14io5	1400	440											
VHF 15-16io5	1600	500											
VHF 25-06io7	600	125	32	85	200	0.85	27	125	1.3	1.8	X101	See data sheet for pin arrangement 	
VHF 25-08io7	800	250											
VHF 25-12io7	1200	400											
VHF 28-08io5	800	250	28	85	300	0.9	15	125	1.4	2.0	X117a	Weight = 35 g 	
VHF 28-12io5	1200	400											
VHF 28-14io5	1400	440											
VHF 28-16io5	1600	500											
VHF 36-08io5	800	250	36	85	320	0.85	13	125	1.15	1.55	X117a		
VHF 36-12io5	1200	400											
VHF 36-14io5	1400	440											
VHF 36-16io5	1600	500											
VHF 55-08io7	800	250	53	85	550	0.85	11	125	0.9	1.1	X118a	Weight = 50 g 	
VHF 55-12io7	1200	400											
VHF 55-14io7	1400	440											
VHF 55-16io7	1600	500											
VHF 85-12io7	1200	400	82	85	1150	0.85	6	125	0.65	0.8	X123a		
VHF 85-14io7	1400	440											
VHF 125-12io7	1200	400	123	85	1500	0.85	3.5	125	0.46	0.55	X123a	Weight = 100 g 	
VHF 125-14io7	1400	440											
VHF 125-16io7	1600	500											
VHFD 16-08io1	800	250	16	85	150	1.0	40	125	2.4	3.0	X103		
VHFD 16-12io1	1200	400											
VHFD 16-14io1	1400	440											
VHFD 16-16io1	1600	500											
VHFD 29-08io1	800	250	28	85	300	0.9	15	125	1.4	2.0	X103		
VHFD 29-12io1	1200	400											
VHFD 29-14io1	1400	440											
VHFD 29-16io1	1600	500											
VHFD 37-08io1	800	250	36	85	320	0.85	13	125	1.2	1.55	X103		
VHFD 37-12io1	1200	400											
VHFD 37-14io1	1400	440											
VHFD 37-16io1	1600	500											

1~ Rectifier Bridges

1~Half Controlled Rectifier Bridge, B2HK

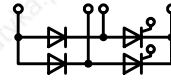

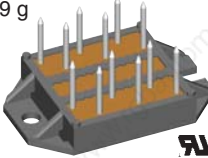
Type	V_{RRM}	V_{VRMS}	I_{dAV} @ T_C		I_{FSM} 45°C 10 ms A	V_{T0}	r_T	T_{VJM}	R_{thJC} R_{thJH} per Chip		Fig. No.	Package style Outline drawings on page 188 - 224
	V	V	A	°C					K/W	K/W		
VHO 55-08io7	800	250	53	85	550	0.85	11	125	0.9	1.1	X118a	X101 Weight = 19 g  See data sheet for pin arrangement
VHO 55-12io7	1200	400										
VHO 55-14io7	1400	440										
VHO 55-16io7	1600	500										

1~ Full Controlled Rectifier Bridge, B2C

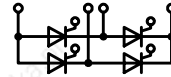

VKO 55-08io7	800	250	53	85	550	0.85	11	125	0.9	1.1	X118a	X106a Weight = 28 g 
VKO 55-12io7	1200	400										
VKO 55-14io7	1400	440										
VKO 55-16io7	1600	500										

1~ Full Controlled Rectifier Bridge, B2CF

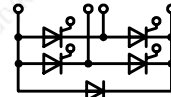

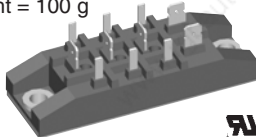
VKF 55-08io7	800	250	53	85	550	0.85	11	125	0.9	1.1	X118a	X118a Weight = 100 g 
VKF 55-12io7	1200	400										
VKF 55-14io7	1400	440										
VKF 55-16io7	1600	500										

1~ Half Controlled Rectifier Bridge, B2HZ

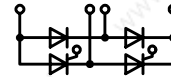

VGO 36-08io7	800	250	36	85	320	0.85	13	125	1.4	2.0	X101	
VGO 36-12io7	1200	400										
VGO 36-14io7	1400	440										
VGO 36-16io7	1600	500										
VGO 55-08io7	800	250	53	85	550	0.85	11	125	0.9	1.1	X118a	
VGO 55-12io7	1200	400										
VGO 55-14io7	1400	440										
VGO 55-16io7	1600	500										

Thyristor Module

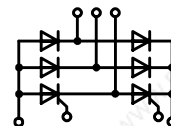

VVY 40-16io1	1600	500	34	100	320	0.85	15	125	1.0	1.6	X106a
--------------	------	-----	----	-----	-----	------	----	-----	-----	-----	-------

1~ / 3~ High Voltage Rectifier Modules

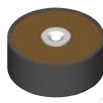
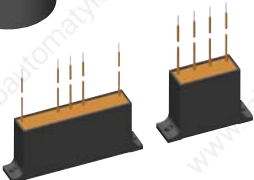

Type	V _{RRM} V	I _{dAV} ① / ② A	I _{FSM} 45°C 10 ms A	V _{T0} V	r _T mΩ	T _{VJM} °C	R _{thJA1} ① K/W	R _{thJA2} ② K/W	Package style
Outline drawings on page 188 - 224									
UGE 0421 AY4	3200	23/7.4	300	1.7	16	150	1.9	7.1	X251 Weight = 130 g 
UGE 0221 AY4	4800	10/3.8	180	2.55	90	150	1.7	8.0	
UGE 1112 AY4	8000	4.2/2.0	120	4.25	215	150	4.2	10.0	
UGE 3126 AY4	24000	2.0/0.8	70	12	1800	150	2.7	8.7	
UGB 3132 AD	4800	1.3	60	-	-	150	-	-	X252 Weight = 150 g X253 Weight = 300 g X253 X253 
UGB 6124 AG	10500	1.0	50	-	-	150	-	-	
UGD 6123 AG	7200	1.8	50	-	-	150	-	-	
UGD 8124 AG	10500	1.2	50	-	-	150	-	-	

Data according to IEC 60747-2/6

① for oil-cooling with cooling plate, T_A = 35°C





② for natural air cooling without cooling plate, T_A = 45°C

High Voltage Rectifiers

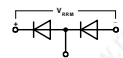
Diode Assembly Range

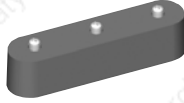

HTZ

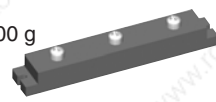
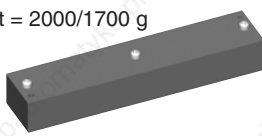
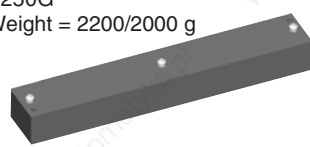
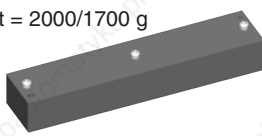
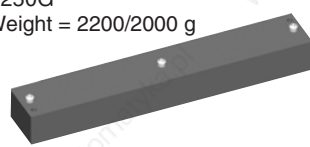
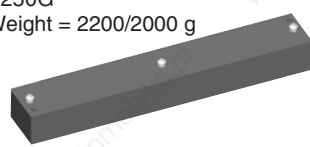
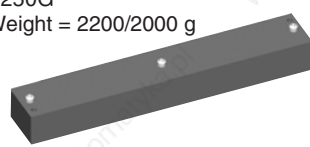
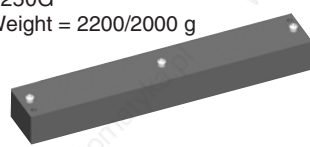

Type ▶ New	V _{RRM} V	I _{F(AV)} A	@ T _A °C	I _{FSM} A	I _{RM} @ T _{VJM} mA	T _{VJ} °C	V _{FM} V	@ I _{FM} A	Fig. No.	Package style
Outline drawings on page 188 - 224										
HTZ110A16K	16000	3.5	35	200	0.5	150	18.3	12	X250A	X250A Weight = 1550/1660 g 
HTZ110A19K	19000									
HTZ110A22K	22000									
HTZ110A25K	25000									
HTZ120A32K	32000	2.0	35	200	0.5	150	36.8	12	X250A	X250B Weight = 380 g 
HTZ120A38K	30000									
HTZ120A44K	44000									
HTZ120A51K	51000									
HTZ130B24K	24000	1.0	35	100	0.5	150	24.0	2.0	X250B	X250C Weight = 240/260/280 g 
HTZ130B28K	28000									
HTZ130B33K	33000									
HTZ130B38K	38000									
HTZ150C6K	6000	3.0	35	100	0.5	150	6.0	2.0	X250C	X250D Weight = 500 g 
HTZ150C7K	7200									
HTZ150C8K	8400									
HTZ150C9K	9600									
HTZ160C12K	12000	1.7	35	100	0.5	150	12.0	2.0	X250C	X250E Weight = 200 g 
HTZ160C14K	14400									
HTZ160C17K	16800									
HTZ160C19K	19200									
HTZ170C2K	2000	10.0	35	1000	0.5	150	1.9	40	X250C	X250F Weight = 2000/1700 g 
HTZ170C2.4K	2400									
HTZ170C2.8K	2800									
HTZ180D22K	22000	1.3	35	100	0.5	150	22.0	2.0	X250D	X250G Weight = 2200/2000 g 
HTZ180D26K	26000									
HTZ180D30K	30000									
HTZ180D35K	35000									
HTZ240F10K	10000	1.7	35	100	0.5	150	10.0	2.0	X250E	X250F Weight = 2000/1700 g 
HTZ240F12K	12000									
HTZ240F14K	14000									
HTZ240F16K	16000									
HTZ250G28K	28000	2.7	35	200	0.5	150	32.0	12	X250F	X250G Weight = 2200/2000 g 
HTZ250G33K	33600									
HTZ250G39K	39200									
HTZ250G44K	44800									
HTZ260G14K	14000	4.7	35	200	0.5	150	16.0	12	X250F	X250G Weight = 2200/2000 g 
HTZ260G16K	16000									
HTZ260G19K	19000									
HTZ260G22K	22000									
HTZ270H40K	40000	3.4	35	200	0.5	150	46.0	12	X250G	X250G Weight = 2200/2000 g 
HTZ270H48K	48000									
HTZ270H56K	56000									
HTZ270H64K	64000									
HTZ280H20K	20000	4.7	35	200	0.5	150	23.0	12	X250G	X250G Weight = 2200/2000 g 
HTZ280H24K	24000									
HTZ280H28K	28000									
HTZ280H32K	32000									

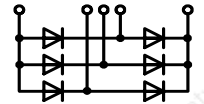
3~ Rectifier Bridges, B6U

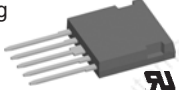
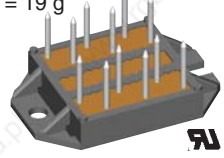

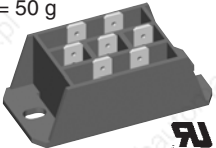
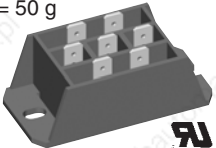
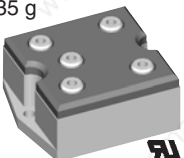
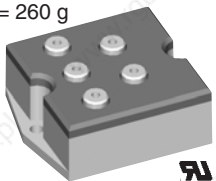





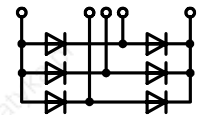

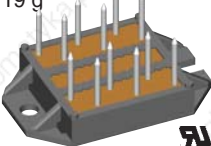
Type	V _{RRM}	V _{VRMS}	I _{dAV}	T _C	I _{FSM} 45°C 10 ms	V _{TO}	r _T	T _{VJM}	R _{thJC} per Chip	R _{thJH}	Fig. No.	Package style		
► New	V	V	A	°C	A	V	mΩ	°C	K/W	K/W		Outline drawings on page 188 - 224		
VUO 16-08NO1 VUO 16-12NO1 VUO 16-14NO1 VUO 16-16NO1 VUO 16-18NO1	800 1200 1400 1600 1800	250 400 440 500 575	15	T _H = 90°C	100	0.8	50	130	-	4.5	X103	X024a ISOPLUS i4-PAC™ Weight = 6 g 		
FUO 22-12N FUO 22-16N	1200 1600	400 500	27		90	100	0.83	28	150	4	5	X024a	X100 Slim-PAC Weight = 17 g 	
VUO 22-08NO1 VUO 22-12NO1 VUO 22-14NO1 VUO 22-16NO1 VUO 22-18NO1	800 1200 1400 1600 1800	250 400 440 500 575	22		T _H = 90°C	100	0.8	40	130	-	3.1	X103	 See data sheet for pin arrangement	
VUO 25-08NO8 VUO 25-12NO8 VUO 25-14NO8 VUO 25-16NO8 VUO 25-18NO8	800 1200 1400 1600 1800	250 400 440 500 575	20			85	380	0.85	12	150	9.3	10.2	X116b	X101 ECO-PAC 1 Weight = 19 g 
VUO 27-08NO7 VUO 27-12NO7	800 1200	250 400	28			100	100	0.8	40	150	2.3	2.8	X100	 See data sheet for pin arrangement
VUO 28-08NO7 VUO 28-12NO7	800 1200	250 400	28	100		100	0.8	40	150	2.3	2.8	X101	 See data sheet for pin arrangement	
VUO 36-08NO8 VUO 36-12NO8 VUO 36-14NO8 VUO 36-16NO8 VUO 36-18NO8	800 1200 1400 1600 1800	250 400 440 500 575	27	85		550	0.8	7.4	150	7.5	8.4	X116b	 See data sheet for pin arrangement	
VUO 34-08NO1 VUO 34-12NO1 VUO 34-14NO1 VUO 34-16NO1 VUO 34-18NO1	800 1200 1400 1600 1800	250 400 440 500 575	36	T _H = 90°C	300	0.8	15	130	-	2.5	X103	X103 Weight = 35 g 		
VUO 30-08NO3 VUO 30-12NO3 VUO 30-14NO3 VUO 30-16NO3 VUO 30-18NO3	800 1200 1400 1600 1800	250 400 440 500 575	37		85	300	0.9	11	125	2.4	3.0	X117b	X116b Weight = 22 g 	
VUO 35-08NO7 VUO 35-12NO7 VUO 35-14NO7 VUO 35-16NO7 VUO 35-18NO7	800 1200 1400 1600 1800	250 400 440 500 575	38		85	400	0.85	12	150	4.2	4.8	X119	X117b Weight = 50 g 	
FUO 50-16N	1600	500	50		90	200	tbd	tbd	150	2.1	3.2	X024a	 Weight = 135 g	
VUO 52-08NO1 VUO 52-12NO1 VUO 52-14NO1 VUO 52-16NO1 VUO 52-18NO1 VUO 52-20NO1	800 1200 1400 1600 1800	250 400 440 500 575	54		T _H = 90°C	350	0.8	12.5	130	-	1.5	X103	X119 Weight = 135 g 	
VUO 50-08NO3 VUO 50-12NO3 VUO 50-14NO3 VUO 50-16NO3 VUO 50-18NO3	800 1200 1400 1600 1800	250 400 440 500 575	58	85		500	0.9	6	125	1.62	2.22	X117b	X120 Weight = 260 g 	
VUO 55-12NO7 VUO 55-14NO7 VUO 55-16NO7 VUO 55-18NO7	1200 1400 1600 1800	400 440 500 575	58	85		750	0.85	8	150	2.7	3.06	X120		
VUO 60-12NO3 VUO 60-14NO3 VUO 60-16NO3 VUO 60-18NO3	800 1400 1600 1800	250 440 500 575	72	85		600	0.8	6.5	125	1.2	1.6	X117b		

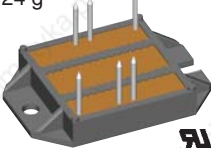
Data according to IEC 60747 and refer to a single diode or thyristor unless otherwise stated.

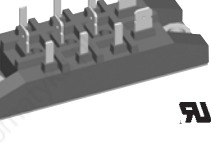
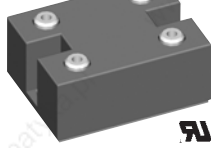

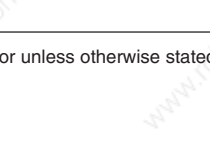
3~ Rectifier Bridges, B6U

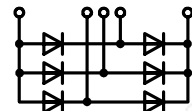

Type	V _{RRM}	V _{VRMS}	I _{dAV}	T _C	I _{FSM} 45°C 10 ms	V _{T0}	r _T	T _{VJM}	R _{thJC} per Chip	R _{thJH}	Fig. No.	Package style
► New	V	V	A	°C	A	V	mΩ	°C	K/W	K/W		Outline drawings on page 188 - 224
VUO 62-08NO7 VUO 62-12NO7 VUO 62-14NO7 VUO 62-16NO7 VUO 62-18NO7	800 1200 1400 1600 1800	250 400 440 500 575	63	110	550	0.8	8	150	1.45	1.87	X122	X101 ECO-PAC 1 Weight = 19 g 
VUO 68-08NO7 VUO 68-12NO7 VUO 68-14NO7 VUO 68-16NO7	800 1200 1400 1600	250 400 440 500	68	100	300	0.8	13	150	1.1	1.6	X101	See data sheet for pin arrangement 
VUO 70-08NO7 VUO 70-12NO7 VUO 70-14NO7 VUO 70-16NO7	800 1200 1400 1600	250 400 440 500	70	100	550	0.8	8	150	1.45	1.9	X118a	X102 ECO-PAC 2 Weight = 24 g 
VUO 80-08NO1 VUO 80-12NO1 VUO 80-14NO1 VUO 80-16NO1 VUO 80-18NO1	800 1200 1400 1600 1800	250 400 440 500 575	82 T _H = 90°C		600	0.8	7.5	150	-	1.42	X103	See data sheet for pin arrangement 
VUO 82-08NO7 VUO 82-12NO7 VUO 82-14NO7 VUO 82-16NO7 VUO 82-18NO7	800 1200 1400 1600 1800	250 400 440 500 575	88	110	750	0.8	5	150	1.1	1.52	X122	X103 Weight = 35 g 
VUO 85-08NO7 VUO 85-12NO7 VUO 85-14NO7 VUO 85-16NO7	800 1200 1400 1600	250 400 440 500	85	100	750	0.8	6	150	1.3	1.6	X118a	X118a Weight = 100 g 
VUO 86-08NO7 VUO 86-12NO7 VUO 86-14NO7 VUO 86-16NO7	600 1200 1400 1600	125 400 440 500	86	90	530	0.8	7.5	150	1.2	1.5	X101	
VUO 98-08NO7 VUO 98-12NO7 VUO 98-14NO7 VUO 98-16NO7	800 1200 1400 1600	250 400 440 500	95	85	750	0.8	6	150	1.2	1.5	X102	X121 Weight = 225 g 
VUO 100-08NO7 VUO 100-12NO7 VUO 100-14NO7 VUO 100-16NO7	800 1200 1400 1600	250 400 440 500	100	100	1000	0.8	5	150	1.12	1.5	X118a	
VUO 105-12NO7 VUO 105-14NO7 VUO 105-16NO7 VUO 105-18NO7	1200 1400 1600 1800	400 440 500 575	140	85	1500	0.8	5	150	0.83	1.13	X121	X122 Weight = 160 g 
VUO 110-08NO7 VUO 110-12NO7 VUO 110-14NO7 VUO 110-16NO7 VUO 110-18NO7	800 1200 1400 1600 1800	250 400 440 500 575	127	110	1200	0.8	4	150	0.90	1.08	X123a	X123a Weight = 300 g 

3~ Rectifier Bridges, B6U

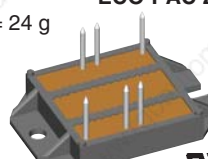
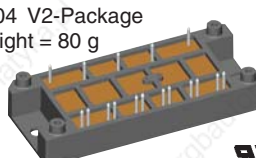
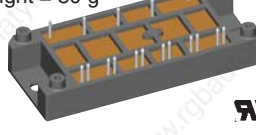
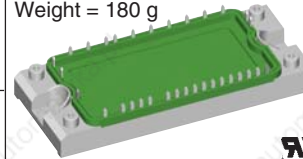

Type	V_{RRM}	V_{VRMS}	I_{dAV}	T_C	I_{FSM} 45°C 10 ms	V_{T0}	r_T	T_{VJM}	R_{thJC} per Chip		Fig. No.	Package style Outline drawings on page 188 - 224	
	V	V	A	°C	A	V	mΩ	°C	K/W	K/W			
► New													
VUO 120-12NO1 VUO 120-16NO1	1200 1600	1200 1600	121	75	650	0.8	6.1	150	1.0	1.3	X104	ECO-PAC 2 Weight = 24 g  See data sheet for pin arrangement	
VUO 121-16NO1	1600	575	118	100	650	0.8	5	150	0.8	0.9	X112		
VUO 122-08NO7 VUO 122-12NO7 VUO 122-14NO7 VUO 122-16NO7 VUO 122-18NO7	800 1200 1400 1600 1800	250 400 440 500 575	117	100	900	0.8	4	150	0.85	1.15	X102		
VUO 155-12NO1 VUO 155-16NO1	1200 1600	1200 1600	157	75	850	0.75	4.6	150	0.8	1.1	X104		X104 V2-Package Weight = 80 g 
VUO 160-08NO7 VUO 160-12NO7 VUO 160-14NO7 VUO 160-16NO7 VUO 160-18NO7	800 1200 1400 1600 1800	250 400 440 500 575	175	90	1800	0.8	3	150	0.65	0.83	X123a		
VUO 125-12NO7 VUO 125-14NO7 VUO 125-16NO7 VUO 125-18NO7	1200 1400 1600 1800	400 440 500 575	166	85	1800	0.8	3	150	0.83	1.13	X121		X112 Weight = 180 g 
VUO 190-08NO7 VUO 190-12NO7 VUO 190-14NO7 VUO 190-16NO7 VUO 190-18NO7	800 1200 1400 1600 1800	250 400 440 500 575	248	110	2800	0.8	2.2	150	0.45	0.6	X123a		

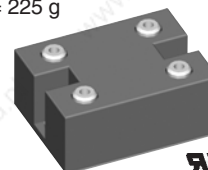

X123a
Weight = 300 g

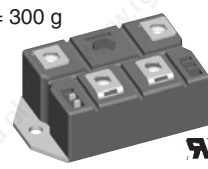

Data according to IEC 60747 and refer to a single diode or thyristor unless otherwise stated.

3~ Rectifier Bridges

3~ Rectifier Bridges with Fast Diodes ($t_{rr} = 1.5 \mu s$) and Integrated Softstart Thyristor

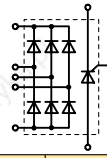

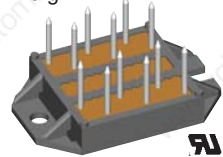
Type	V_{RRM}	V_{VRMS}	I_{dAVM} T_H		I_{FSM} 45°C 10 ms A	V_{TO}	r_T	T_{VJM}	R _{thJC} per Chip		Fig. No.	Package style Outline drawings on page 188 - 224
	V	V	A	°C					K/W	K/W		
VUC 25-12go2	1200	400	25 85	Dio.	300	1.2	18	125	2.3	2.9	X106	ECO-PAC 1 Weight = 19 g  See data sheet for pin arrangement
VUC 25-14go2	1400	440										
VUC 25-16go2	1600	500										
VUC 36-12go2	1200	400	34 85	Dio.	300	1.2	16	125	1.4	2.0		
VUC 36-14go2	1400	440										
VUC 36-16go2	1600	500										

3~ Half Controlled Rectifier Bridges, B6HK

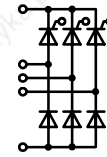

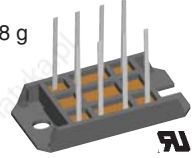
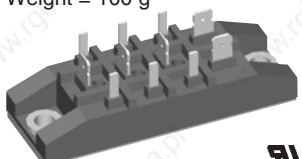
Type	V_{RRM}	V_{VRMS}	I_{dAV} $T_H=100^\circ C$	I_{FSM} 45°C 10 ms A	V_{TO}	r_T	T_{VJM}	R _{thJC} per Chip		Fig. No.								
	V	V	A	A				K/W	K/W									
► New VVZ 12-12io1 VVZ 12-14io1 VVZ 12-16io1	1200 1400 1600	400 440 500	15	110	1.1	30	125	2.5	3.1	X106a	X106a Weight = 28 g 							
VVZ 24-12io1 VVZ 24-14io1 VVZ 24-16io1	1200 1400 1600	400 440 500										21	300	1.0	16	125	2.1	2.7
VVZ 39-08ho7 VVZ 39-12ho7	800 1200	250 400																
VVZ 40-12io1 VVZ 40-14io1 VVZ 40-16io1	1200 1400 1600	400 440 500	34	320	0.85	15	125	1.0	1.6									
VVZ 70-08io7 VVZ 70-12io7 VVZ 70-14io7 VVZ 70-16io7	800 1200 1400 1600	250 400 440 500	70 $T_C = 85^\circ C$	550	0.85	11	125	0.9	1.1			X118a	X118a Weight = 100 g 					
VVZ 110-12io7 VVZ 110-14io7	1200 1400	400 440												110 $T_C = 85^\circ C$	1150	0.85	6	125
VVZ 175-12io7 VVZ 175-14io7 VVZ 175-16io7	1200 1400 1600	400 440 500								167 $T_C = 85^\circ C$	1500			0.85	3.5	125	0.46	0.55

3~ Half Controlled Rectifier Bridges with free wheeling diode, B6HKF

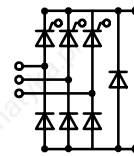

Type	V_{RRM}	V_{VRMS}	I_{dAV} $T_C = 85^\circ C$	I_{FSM} 45°C 10 ms A	V_{TO}	r_T	T_{VJM}	R _{thJC} per Chip		Fig. No.	
	V	V	A	A				K/W	K/W		
VVZF 70-08io7 VVZF 70-12io7 VVZF 70-14io7 VVZF 70-16io7	800 1200 1400 1600	250 400 440 500	70	550	0.85	11	125	0.9	1.1	X118a	X118a Weight = 300 g 

3~ Rectifier Bridges

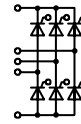

3~ Full Controlled Rectifier Bridges, B6C

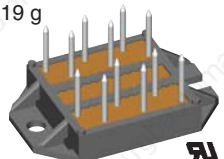
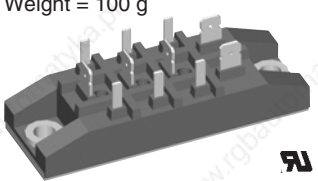
Type	V _{RRM}	V _{VRMS}	I _{dAV} T _c =100°C	I _{TSM} 45°C 10 ms	V _{T0}	r _T	T _{VJM}	R _{thJC} R _{thJH} per Chip		Fig. No.	Package style
► New	V	V	A	A	V	mΩ	°C	K/W	K/W		Outline drawings on page 188 - 224
VTO 39-08ho7 VTO 39-12ho7	800 1200	250 400	39 T _c = 85°C	200	0.85	27	125	1.3	1.8	X101	X101 ECO-PAC 1 Weight = 19 g 
VTO 70-08io7 VTO 70-12io7 VTO 70-14io7 VTO 70-16io7	800 1200 1400 1600	250 400 440 500	70 T _c = 85°C	550	0.85	11	125	0.9	1.1	X118a	
VTO 110-12io7 VTO 110-14io7	1200 1400	400 440	110	1150	0.85	6	125	0.65	0.80	X123b	See data sheet for pin arrangement 
VTO 175-12io7 VTO 175-14io7 VTO 175-16io7	1200 1400 1600	400 440 500	167	1500	0.85	3.5	125	0.46	0.55	X118a	

3~ Full Controlled Rectifier Bridge with free wheeling diode, B6CF

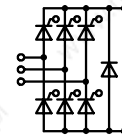

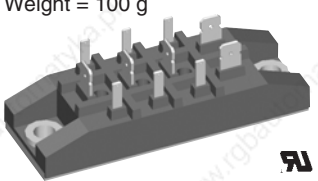
VTOF 70-08io7 VTOF 70-12io7 VTOF 70-14io7 VTOF 70-16io7	800 1200 1400 1600	250 400 440 500	70 T _c = 85°C	550	0.85	11	125	0.9	1.1	X118a	X118a Weight = 100 g 

AC Controller 1~ / 2~ / 3~

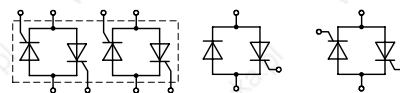



VW 2x...

MLO

MMO

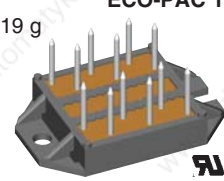
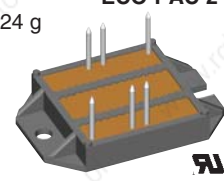
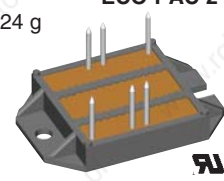
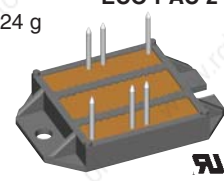
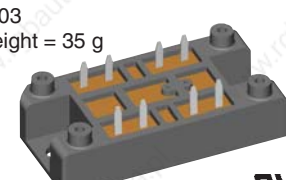
$I_{RMS} = 30 - 230 \text{ A}$

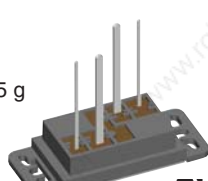
Type	V_{RRM}	V_{VRMS}	I_{RMS} $T_c = 85^\circ\text{C}$	I_{TSM} 45°C 10 ms	V_{T0}	r_T	T_{VJM}	R_{thJC} per Chip	R_{thJH}	Fig. No.	Package style
► New	V	V	A	A	V	mΩ	°C	K/W	K/W		Outline drawings on page 188 - 224
MLO 36-12io1 MLO 36-16io1	1200 1600	400 500	39	360	0.85	15	125	1.3	1.5	X106b	X027a Weight = 30 g SOT-227B miniBLOC 
MLO 75-12io1 MLO 75-16io1	1200 1600	400 500	86	1150	0.85	5	125	0.55	0.75		
MLO 110-08io7 MLO 110-12io7 MLO 110-14io7	800 1200 1400	250 400 440	112	1000	0.85	5.6	150	0.8	0.92	X101	X101 Weight = 19 g ECO-PAC 1 
MLO 140-08io7 MLO 140-12io7 MLO 140-16io7	800 1200 1600	250 400 500	130	1150	0.85	5.2	150	0.7	0.82		
MLO 175-08io7 MLO 175-12io7 MLO 175-16io7	800 1200 1600	250 400 500	175	1500	0.85	3.7	150	0.5	0.62		
MLO 230-08io7 MLO 230-12io7 MLO 230-14io7 MLO 230-16io7 MLO 230-18io7	800 1200 1400 1600 1800	250 400 440 500 575	230	2250	0.8	2.4	125	0.26	0.46	X102	X102 Weight = 24 g ECO-PAC 2 
MMO 36-12io1 MMO 36-16io1	1200 1600	400 500	39	360	0.85	15	125	1.3	1.5	X106a	
MMO 75-12io1 MMO 75-16io1	1200 1600	400 500	86	1150	0.85	5	125	0.55	0.75	X102	X102 Weight = 24 g ECO-PAC 2 
MMO 62-12io6 MMO 62-16io6	1200 1600	400 500	54 $T_c = 110^\circ\text{C}$	400	0.85	12	125	0.91	1.01	X027a	
MMO 74-12io6 MMO 74-16io6	1200 1600	400 500	74 $T_c = 110^\circ\text{C}$	600	0.85	8.4	150	0.71	0.81		
MMO 90-12io6 MMO 90-14io6 MMO 90-16io6	1200 1400 1600	400 440 500	90 $T_c = 111^\circ\text{C}$	800	0.9	5.8	150	0.6	0.7		See data sheet for pin arrangement 
MMO 110-08io7 MMO 110-12io7 MMO 110-14io7	800 1200 1400	250 400 440	112	1000	0.85	5.6	150	0.8	0.92	X101	
MMO 140-08io7 MMO 140-12io7 MMO 140-16io7	800 1200 1600	250 400 500	130	1150	0.85	5.2	150	0.7	0.82	X103	X103 Weight = 35 g 
MMO 175-08io7 MMO 175-12io7 MMO 175-16io7	800 1200 1600	250 400 500	175	1500	0.85	3.7	150	0.5	0.62		
MMO 230-08io7 MMO 230-12io7 MMO 230-14io7 MMO 230-16io7 MMO 230-18io7	800 1200 1400 1600 1800	250 400 440 500 575	230	2250	0.8	2.4	125	0.26	0.46	X102	
VW 2x30-08io1 VW 2x30-12io1 VW 2x30-14io1 VW 2x30-16io1	800 1200 1400 1600	250 400 440 500	2x30	200	0.8	25	125	1.7	2.0	X103	X106b Weight = 15 g 
VW 2x45-08io1 VW 2x45-12io1 VW 2x45-14io1 VW 2x45-16io1	800 1200 1400 1600	250 400 440 500	2x45	300	0.85	15	125	1.25	1.55		
VW 2x60-08io1 VW 2x60-12io1 VW 2x60-14io1 VW 2x60-16io1	800 1200 1400 1600	250 400 440 500	2x60	520	0.85	11	125	0.92	1.22	X106a	X106a Weight = 15 g 

AC Controller 1~ / 2~ / 3~

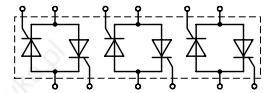

VWO

$$I_{RMS} = 39 - 143 \text{ A}$$

Type	V _{RRM}	V _{VRMS}	I _{RMS} T _C = 85°C	I _{TSM} 45°C 10 ms	V _{T0}	r _T	T _{VJM}	R _{thJC} per Chip	R _{thJH}	Fig. No.	Package style		
► New	V	V	A	A	V	mΩ	°C	K/W	K/W		Outline drawings on page 188 - 224		
3	VWO 35-08ho7	800	250	3x35	200	0.85	27	125	1.3	1.8	X101	X101 Weight = 19 g	
	VWO 35-12ho7	1200	400										
	VWO 36-08io7	800	250	3x39	320	0.85	13	125	1.3	1.5	X118a	X118a Weight = 100 g	
	VWO 36-12io7	1200	400										
	VWO 36-14io7	1400	440										
	VWO 36-16io7	1600	500										
				T _H = 85°C									
	VWO 40-08io7	800	250	3x40	400	0.85	15	125	1.43	1.53	X124	X124 Weight = 180 g	
	VWO 40-12io7	1200	400										
	VWO 40-14io7	1400	440										
	VWO 40-16io7	1600	500										
	VWO 50-08io7	800	250	3x50	520	0.85	11	125	1.2	1.31	X124	X124 Weight = 80 g	
VWO 50-12io7	1200	400											
VWO 50-14io7	1400	440											
VWO 50-16io7	1600	500											
VWO 60-08io7	800	250	3x60	550	0.85	11	125	0.9	1.1	X118a	X118a Weight = 100 g		
VWO 60-12io7	1200	400											
VWO 60-14io7	1400	440											
VWO 60-16io7	1600	500											
			T _H = 85°C										
VWO 85-08io1	800	250	3x83	520	0.85	11	150	0.92	1.22	X104	X104		
VWO 85-12io1	1200	400											
VWO 85-14io1	1400	440											
VWO 85-16io1	1600	500											
VWO 80-08io7	800	250	3x82	1000	0.85	5.2	125	0.81	1.0	X124	X124		
VWO 80-12io7	1200	400											
VWO 80-14io7	1400	440											
VWO 95-08io7	800	250	3x96	1150	0.85	4.8	125	0.66	0.93		X124 Weight = 180 g		
VWO 95-12io7	1200	400											
VWO 95-14io7	1400	440											
VWO 140-08io1	800	250	3x143	1150	0.85	5.2	150	0.6	0.7	X104	X104		
VWO 140-12io1	1200	400											
VWO 140-14io1	1400	440											
VWO 140-16io1	1600	500											

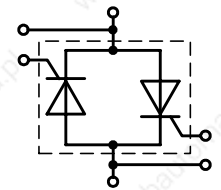

1~ AC Controller with isolated Water Cooling

Type	V _{RRM}	V _{VRMS}	I _{RMS} T _{water} = 17 °C 4l/min	I _{TSM} 45°C 10 ms	V _{T0}	r _T	T _{VJM}	R _{thJW} per Chip 4l/min K/W	Package style	
	V	V	A	A	V	mΩ	°C		Outline drawings on page 188 - 224	
1~	HVL 900-12io1	1200	400	900	9200	0.8	0.68	140	0.203	X133 Weight = 1300 g
	HVL 900-14io1	1400	440							
	HVL 900-16io1	1600	500							
	HVL 900-18io1	1800	590							

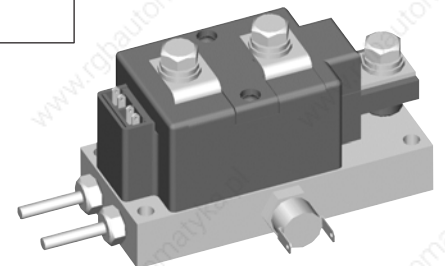

Data according to IEC 60747 and refer to a single diode or thyristor unless otherwise stated.

Braking Rectifier Assemblies

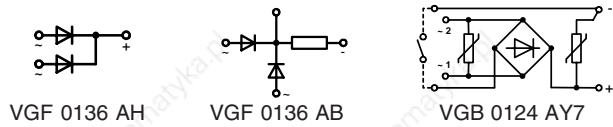

Type	Typical				Max.			Fig. No.	Package style Outline drawings on page 188 - 224
	V_{VRMS} V	V_{dAV} V	I_{dAVM} A	I_{dAVM} A	V_{RRM} V	I_{FSM} A	I^2t A ² s		
VGB 0124 AY7a	380	340	1.0	1.0	1400	60	28	X254	X256 Weight = 50 g
VGF 0136 AB	1000	440	1.2	1.5	2800	80	40	X255	
VGF 0136 AH	1000	440	0.6	1.1	1400	60	28	X256	

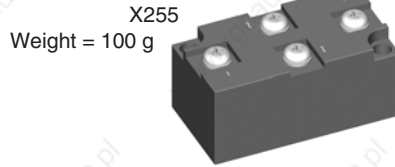
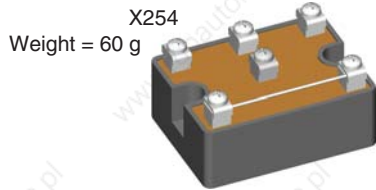

Breakover Diodes



Type	V_{BO} V	I_{BO} $T_{VJ} = 25^\circ\text{C}$ mA	I_D 125 °C μA	I_H $T_J = 25^\circ\text{C}$ mA	V_H $T_{VJ} = 25^\circ\text{C}$ V	I_{AVM} ① 50 °C A	I_{SM} 50 °C A	dv/dt V/ μs	R_{thJA} $^\circ\text{C}/\text{W}$	Fig. No.	Package style Outline drawings on page 188 - 224
► New	V										
IXBOD 1-06	600 ±50	≤15	20	30	4-8	0.9	200	>1000	60	X201	X201 Weight = 0.8 g
IXBOD 1-07	700		0.8 x V_{BO}								
IXBOD 1-08	800										
IXBOD 1-09	900										
IXBOD 1-10	1000										
IXBOD 1-12 R(D)	1200 ±50	≤15	100	30	4-8	1.25	200	>1000	20	X202	
IXBOD 1-13 R(D)	1300		0.8x V_{BO}								
IXBOD 1-14 R(D)	1400										
IXBOD 1-15 R(D)	1500										
IXBOD 1-16 R(D)	1600 ±50	≤15		100	30	4-8	1.25	200	>1500	20	
IXBOD 1-17 R(D)	1700										
IXBOD 1-18 R(D)	1800										
IXBOD 1-19 R(D)	1900										
IXBOD 1-20 R(D)	2000 ±50	≤15	100	30	4-8	0.9	200	>1500	20		X202 Weight = 14 g
IXBOD 1-21 R(D)	2100 ±50	≤15	100	30	4-8	0.9	200	>2000	20		
IXBOD 1-22 R(D)	2200										
IXBOD 1-23 R(D)	2300										
IXBOD 1-24 R(D)	2400										
IXBOD 1-25 R(D)	2500										
IXBOD 1-26 R(D)	2600 ±100	≤15	100	30	4-8	0.7	200	>2500	20		
IXBOD 1-28 R(D)	2800										
IXBOD 1-30 R(D)	3000										
IXBOD 1-32 R(D)	3200 ±100	≤15	100	30	4-8	0.7	200	>3000	20		
IXBOD 1-34 R	3400										
IXBOD 1-36 R	3600 ±100	≤15	100	30	4-8	0.7	200	>3500	20		
IXBOD 1-38 R	3800										
IXBOD 1-40 R	4000										
IXBOD 1-42 R	4200										

① Leads soldered on PCB board, T_s and $T_{VJ} = -40 \dots +125^\circ\text{C}$

Break-Over-Diodes Sets

We deliver also:

- Special selection of more than 2 pcs IXBOD1-... for every break down voltage of $V_{BO} > 2000 \text{ V}$

- Example

type designation IXBOD Set SA05/00

$V_{BO} = 4700 \text{ V} \pm 100 \text{ V}$

(we deliver 5pcs single selected IXBOD1-... in one plastic bag)

Customer use these products on PCB connected in series with parallel resistor $R = 10 \text{ M}\Omega$

across each IXBOD

Integrated Circuits

Ultra-fast Power MOSFET / IGBT Drivers

These ultra-fast high current drivers are optimized for high efficiency performance in the motor drive and power conversion applications. They are designed to switch largest MOSFETs and IGBTs with minimum switching times at frequencies to 10 MHz. These MOSFET/IGBT drivers are manufactured in industry standard outlines, which include TO-263, TO-220 and many IC packages offering superior thermal performance.

Features

- Wide operating voltage range from 4.5 V to 35 V
- Rated for -55 °C to +125 °C operation
- Very Low output impedance
- No internal cross conduction which allows operating frequency to 10 MHz
- Latch-up protected to rated reverse current
- Output Current - up to 30 A peak
- Very low thermal impedance for TO-263 & TO-220 packages
- Matched rise and fall times
- ENABLE pin for emergency shutdown
- TTL or CMOS input signals
- Grounded base tab in 8-Pin SOIC-CT, 14-Pin SOIC-CT, 16-PIN SOIC-CT and 28 Pin SOIC-CT packages for PC board cooling.

Applications

- Inverters
- SMPS Class D Amplifiers
- Power Factor Correction
- Motor drives
- Line drivers
- Traction
- Radiology and laser technology

Low Side MOSFET/IGBT Gate Driver Selection Guide

Part Number	Type	Logic Configuration	I _{PK} Output Current A	Output Resistance Ohm	Package (See Note 1)	Notes	Fig. No.	Outline drawings on page 188 - 224
IXDI402PI	Dual	Inverting	2	4	8-pin DIP	-	X500	X531 
IXDI402SI		Inverting			-	X501		
IXDI402SI-16		Inverting			-	X531		
IXDI402SIA		Inverting			-	X501		
IXDI402SIA-16		Inverting			-	X531		
IXDN402PI		Non-inverting			-	X500		
IXDN402SI		Non-inverting			-	X501		
IXDN402SI-16		Non-inverting			-	X531		
IXDN402SIA		Non-inverting			-	X501		
IXDN402SIA-16		Non-inverting			-	X531		
IXDF402PI		Non-inverting / Inverting			-	X500		
IXDF402SI		Non-inverting / Inverting			-	X501		
IXDF402SI-16		Non-inverting / Inverting			-	X531		
IXDF402SIA		Non-inverting / Inverting			-	X501		
IXDF402SIA-16		Non-inverting / Inverting			-	X531		
IXDI404PI		Dual			Inverting	4	2.5	
IXDI404SI	Inverting		-	X501				
IXDI404SI-16	Inverting		-	X531				
IXDI404SIA	Inverting		-	X501				
IXDI404SIA-16	Inverting		-	X531				
IXDN404PI	Non-inverting		-	X500				
IXDN404SI	Non-inverting		-	X501				
IXDN404SI-16	Non-inverting		-	X531				
IXDN404SIA	Non-inverting		-	X501				
IXDN404SIA-16	Non-inverting		-	X531				
IXDD404PI	Non-inverting		2	X500				
IXDD404SI	Non-inverting		2	X501				
IXDD404SI-16	Non-inverting		2	X531				
IXDD404SIA	Non-inverting		2	X501				
IXDD404SIA-16	Non-inverting		2	X531				
IXDF404PI	Non-inverting / Inverting		-	X500				
IXDF404SI	Non-inverting / Inverting	-	X501					
IXDF404SI-16	Non-inverting / Inverting	-	X531					
IXDF404SIA	Non-inverting / Inverting	-	X501					
IXDF404SIA-16	Non-inverting / Inverting	-	X531					





Notes

1. SOIC packages with suffix letter 'CT' have a grounded base solder tab.
2. Includes ENABLE function.
3. Includes ENABLE function + UVSEL=11.75V.
4. Includes ENABLE function + UVSEL=8.5V.
5. Includes ENABLE function + Programmable UVSEL voltage level.

Integrated Circuits

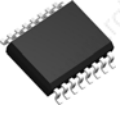
Ultra-fast Power MOSFET / IGBT Drivers

Low Side MOSFET/IGBT Gate Driver Selection Guide

Part Number	Type	Logic Configuration	I _{PK} Output Current A	Output Resistance Ohm	Package (See Note 1)	Notes	Fig. No.	Outline drawings on page 188 - 224			
IXDI409CI	Single	Inverting	9	1.5	5-leaded TO-220	-	X006	X531 16 pin SOP 			
IXDI409PI		Inverting			8-pin DIP	-	X500				
IXDI409SI		Inverting			8-pin SOP-CT	-	X501				
IXDI409YI		Inverting			5-leaded TO-263	-	X012a				
IXDN409CI		Non-inverting			5-pin TO-220	-	X006				
IXDN409PI		Non-inverting			8-pin DIP	-	X500				
IXDN409SI		Non-inverting			8-pin SOP-CT	-	X501				
IXDN409YI		Non-inverting			5-pin TO-263	-	X012a				
IXDD409CI		Non-inverting			5-pin TO-220	2	X006				
IXDD409PI		Non-inverting			8-pin DIP	2	X500				
IXDD409SI		Non-inverting			8-pin SOP-CT	2	X501				
IXDD409YI		Non-inverting			5-pin TO-263	2	X012a				
IXDI414CI	Single	Inverting	14	1	5-pin TO-220	-	X006	X500 8-pin DIP 			
IXDI414PI		Inverting			8-pin DIP	-	X500				
IXDI414SI		Inverting			14-pin SOP-CT	-	X521				
IXDI414YI		Inverting			5-pin TO-263	-	X012a				
IXDN414CI		Non-inverting			5-pin TO-220	-	X006				
IXDN414PI		Non-inverting			8-pin DIP	-	X500				
IXDN414SI		Non-inverting			14-pin SOP-CT	-	X521				
IXDN414YI		Non-inverting			5-pin TO-263	-	X012a				
IXDD414CI		Non-inverting			5-pin TO-220	2	X006				
IXDD414PI		Non-inverting			8-pin DIP	2	X500				
IXDD414SI		Non-inverting			14-pin SOP-CT	2	X521				
IXDD414YI		Non-inverting			5-pin TO-263	2	X012a				
IXDI430CI	Single	Inverting	30	0.4	5-pin TO-220	3	X006	X006 TO-220 (5) 			
IXDI430MCI		Inverting			5-pin TO-220	4	X006				
IXDI430MYI		Inverting			5-pin TO-263	4	X012a				
IXDI430YI		Inverting			5-pin TO-263	3	X012a				
IXDN430CI		Non-inverting			5-pin TO-220	3	X006				
IXDN430MCI		Non-inverting			5-pin TO-220	4	X006				
IXDN430MYI		Non-inverting			5-pin TO-263	4	X012a				
IXDN430YI		Non-inverting			5-pin TO-263	3	X012a				
IXDD430CI		Non-inverting			5-pin TO-220	3	X006				
IXDD430MCI		Non-inverting			5-pin TO-220	4	X006				
IXDD430MYI		Non-inverting			5-pin TO-263	4	X012a				
IXDD430YI		Non-inverting			5-pin TO-263	3	X012a				
IXDS430SI		Non-inverting / Inverting			28-pin SOP-CT	5	X550				
											X012a TO-263(5) 
											X501 8-pin SOP 

Notes

1. SOIC packages with suffix letter 'CT' have a grounded base solder tab.
2. Includes ENABLE function.
3. Includes ENABLE function + UVSEL = 11.75 V
4. Includes ENABLE function + UVSEL = 8.5 V.
5. Includes ENABLE function + Programmable UVSEL voltage level.

Half-Bridge Gate Drivers

Drivers from 0.6 A to 6.0 A with Superior Noise Immunity and Higher Power Handling Capability for Critical applications

IXYS 600V Half-Bridge Driver IC Product Line is a family of surface mount and leaded ICs optimized for gate drive applications up to 600V. This family provides a complete spectrum of solutions with 0.6A peak to 6.0A peak output drive current capability for applications ranging from 1 kHz to 1MHz. These Drivers draw upon a newly optimized architecture first introduced with the IX6R11, building on and enhancing the superior performance and high-end current handling capability of the IX6R11. As with the original IX6R11, IXYS 600V Driver IC Family gives better matching of propagation delays, enhanced fault tolerance and reliability, with improved efficiency and cooler operation.

This Half-Bridge Driver Family provides compatibility with similar Drivers from other suppliers, while offering the superior performance of our architecture. The Family also provides unique Customer options in packaging and configurations. Several Drivers are offered in packages that offer small size (16-Pin SOIC, 48-Pin SSLGA) or thermal advantages (18-Pin SOIC-CT). A unique product configuration is the IX6S11, offered for split-rail circuit configurations (+300V/-200V), with control logic ground referenced.

Performance advantages common to IXYS Half-Bridge Driver ICs include 50 V/ns dV/dt noise immunity and 200V negative voltage transient immunity, 8 times that of competing Half-Bridge Drivers. Noise immunity is further enhanced by the use of non-latching level translation. IXYS level translation technique exhibits lower power dissipation versus techniques using high-voltage transistors typical of competing Half-Bridge Drivers. Lower dissipation enables the use of IXYS Drivers for larger loads, at higher bus voltages, and for higher switching frequencies. Lower dissipation means also that IXYS Drivers can be pushed to higher temperatures.

This Family of Drivers offers a wide mix of user options for input logic types, output current ratings and packages. The high peak current capability of the IX6R11 enables one to drive larger MOSFET and IGBT die sizes at higher frequency without additional discrete transistors and components. 600mA Drivers, such as the IXD611, are used in lower power/lower frequency applications such as small power tools. Other user options covered by this Family include fixed and programmable delays, shutdown options, protection features, as well as high and low side under voltage protection. Other performance advantages include extended voltage range operation, and extended temperature operation from -40°C to +125°C.

IXYS is a global leader in Power Semiconductors, Gate Drive ICs and RF Power Devices. With over 20 years experience, IXYS products are designed to meet the demands of the power market for best-in-class Performance, Quality and Reliability.

Applications

- Welding
- Power Factor Correction
- Offline Power Conversion
- UPS
- Appliance
- Battery Chargers
- Automotive
- Motor Drive

Features

- Floating High Side Driver with bootstrap Power supply along with a Low Side Driver.
- $I_{PK} = 0.6A$ to 6A
- Full operation to 600V BUS
- ± 50 V/ns dV/dt noise immunity
- Gate drive voltage range of 10V to 35V
- Non-latching level translation
- -200V high side drive signal negative transient immunity (8X greater than competitor)
- Versions including undervoltage protection, enable / shutdown functions, fixed and programmable delays, cross-conduction prevention and programmable current limits
- Heat-sinkable versions, such as the 18-Pin SOIC-CT, $R_{THJC} = 3^{\circ}C/W$
- High Density SMD and Hybrid Package Options.
- Extended temperature: -40°C to +125°C
- Rail to rail gate drive voltage swing
- Immune to negative voltage transients
- Separate Logic power supply range: 3.3 V to V_{CL}

Benefits

- Higher switching frequency with larger devices
- Replaces multiple ICs and discrete components
- Full operation to 600V BUS
- Fault tolerant due to non-latching architecture

Integrated Circuits

MOSFET / IGBT Half-Bridge Gate Drivers

Part Number ➤ New	Closet IR Cross	I_{PK} $T_C=25^\circ\text{C}$ A	Shutdown	Inputs / Keying	Protection Features	Deadtime	Package (Note 1)	Fig. No.
➤ IXA611P7 ②	IR2112	0.6	Yes (High)	Dual/In Phase	No	No	14-Pin PDIP	X520
➤ IXA611S3 ②	IR2112S		Yes (High)	Dual/In Phase	No	No	16-Pin SOP	X531
➤ IXB611P1 ②	IR2103		No	Dual/High-In Phase/Low-Inv	Cross-Conduct	Fixed-520ns Typ	8-Pin PDIP	X500
➤ IXB611S1 ②	IR2103S		No	Dual/High-In Phase/Low-Inv	Cross-Conduct	Fixed-520ns Typ	8-Pin SOP	X501
➤ IXC611P1 ②	IR2111		No	Single/High Side	Cross-Conduct	Fixed-650ns Typ	8-Pin PDIP	X500
➤ IXC611S1 ②	IR2111S		No	Single/High Side	Cross-Conduct	Fixed-650ns Typ	8-Pin SOP	X501
➤ IXD611P1 ②	IR2106		No	Dual/In Phase	No	No	8-Pin PDIP	X500
➤ IXD611P7 ②	IR2106		No	Dual/In Phase	No	No	14-Pin PDIP	X520
➤ IXD611S1 ②	IR2106S		No	Dual/In Phase	No	No	8-Pin SOP	X501
➤ IXD611S7 ②	IR2106S		No	Dual/In Phase	No	No	14-Pin SOP	X521
➤ IXE611P1 ③	IR2301		No	Dual/In Phase	No	No	8-Pin PDIP	X500
➤ IXE611S1 ③	IR2301S		No	Dual/In Phase	No	No	8-Pin SOP	X501
➤ IXF611P1 ③	IR2302		Yes (Low)	Single/High Side	Cross-Conduct	Fixed-540ns Typ	8-Pin PDIP	X500
➤ IXF611S1 ③	IR2302S		Yes (Low)	Single/High Side	Cross-Conduct	Fixed-540ns Typ	8-Pin SOP	X501
➤ IXG611P1 ②	IR2304		No	Dual/In Phase	Cross-Conduct	Fixed-100ns Typ	8-Pin PDIP	X500
➤ IXG611S1 ②	IR2304S		No	Dual/In Phase	Cross-Conduct	Fixed-100ns Typ	8-Pin SOP	X501
➤ IXH611P1 ②	IR2308		No	Dual/In Phase	Cross-Conduct	Fixed-540ns Typ	8-Pin PDIP	X500
➤ IXH611S1 ②	IR2308S		No	Dual/In Phase	Cross-Conduct	Fixed-540ns Typ	8-Pin SOP	X501
➤ IXJ611P1 ②	IR2101		No	Dual/In Phase	No	No	8-Pin PDIP	X500
➤ IXJ611S1 ②	IR2101S		No	Dual/In Phase	No	No	8-Pin SOP	X501
➤ IXK611P1 ②	IR2102	No	Dual/Out of Phase	No	No	8-Pin PDIP	X500	
➤ IXK611S1 ②	IR2102S	No	Dual/Out of Phase	No	No	8-Pin SOP	X501	
➤ IX2A11P1 ②	IR2184	2	Yes (Low)	Single/High Side	Cross-Conduct	Fixed-500ns Typ	8-Pin PDIP	X500
➤ IX2A11S1 ②	IR2184S		Yes (Low)	Single/High Side	Cross-Conduct	Fixed-500ns Typ	8-Pin SOP	X501
➤ IX2B11P7 ②	IR21844		Yes (Low)	Single/High Side	Cross-Conduct	Programmable	14-Pin PDIP	X520
➤ IX2B11S7 ②	IR21844S		Yes (Low)	Single/High Side	Cross-Conduct	Programmable	14-Pin SOP	X521
➤ IX2C11P1 ②	IR2181		No	Dual/In Phase	No	No	8-Pin PDIP	X500
➤ IX2C11S1 ②	IR2181S		No	Dual/In Phase	No	No	8-Pin SOP	X501
➤ IX2D11P7 ②	IR21814		No	Dual/In Phase	No	No	14-Pin PDIP	X520
➤ IX2D11S7 ②	IR21814S		No	Dual/In Phase	No	No	14-Pin SOP	X521
➤ IX2R11P7 ②	IR2113		Yes (High)	Dual/In Phase	No	No	14-Pin PDIP	X520
➤ IX2R11S3 ②	IR2113S		Yes (High)	Dual/In Phase	No	No	16-Pin SOP	X531
➤ IX4R11P7 ②	IR2113	4	Yes (High)	Dual/In Phase	No	No	14-Pin PDIP	X520
➤ IX4R11S3 ②	IR2113S		Yes (High)	Dual/In Phase	No	No	16-Pin SOP	X531
➤ IX6R11P7 ②	IR2113	6	Yes (High)	Dual/In Phase	No	No	14-Pin PDIP	X520
➤ IX6R11S3 ②	IR2113S		Yes (High)	Dual/In Phase	No	No	16-Pin SOP	X531
➤ IX6R11S6 ②	IR2113S		Yes (High)	Dual/In Phase	No	No	18-Pin SOIC-CT	X542
➤ IX6S11S6 ②	None		No	Dual/In Phase	No	No	18-Pin SOIC-CT	X542

② UVLO Level for MOSFETs
③ UVLO Level for Logic
Note 1. SOIC packages with suffix letter 'CT' have a grounded base solder tab.

Outline drawings on page 188 - 224

3 phase Driver

Part Number ➤ New	Closet IR Cross	I_{PK} $T_C=25^\circ\text{C}$ A	UVLO Level IGBT, MOSFET LOGIC	Shutdown	Inputs / Keying	Protection Features	Deadtime	Package	Fig. No.
➤ IXA531L4 ①	IR21363J	0.6	IGBT	No	Six/ Out of Phase	Cross-, Conduct OCP (Prog. Reset)	No	44-Pin PLCC	X585
➤ IXA531S10 ①	IR21363J	0.6	IGBT	No	Six/ Out of Phase	Cross-Conduct OCP (Prog. Reset)	No	48-Pin SSLGA	X595

① UVLO Level for IGBTs

Outline drawings on page 188 - 224

Integrated Circuits

ISOSMART® Half Bridge Driver Chipset: IXBD4410, 4411 and TX02-4400 Isolation Transformer

Features

- 1200 V or greater low- to high-side isolation
- Drives power systems operating from industrial AC mains
- dv/dt immunity of greater than 50 V/ns
- Proprietary low- to high-side level-translation and communication
- On-chip negative gate-drive supply to ensure power MOSFET or IGBT turn-off under all conditions
- 5 V logic compatible HCMOS input logic with hysteresis
- 20 ns switching time with 1000 pF load: 100 ns switching time with 10 000 pF load
- 100 ns propagation delay time
- 2 A peak output drive capability
- Self shut-down of output in response to over-current or short-circuit
- Under-voltage lockout protection
- Protection from cross conduction of the half bridge
- Logic compatible fault indication from both low and high side driver

Applications

- 1-, 2- or 3-phase motor control
- Switch mode power supplies (SMPS)
- 1- or 3-phase UPS systems
- Induction heating and welding
- Switching amplifiers
- General power conversion circuits

These chipsets are intended to drive the gates of a pair of power MOSFETs or IGBTs connected in the totem-pole (phase leg) configuration used in PWM inverter bridges for variable speed AC motor drives, or in any other application requiring half bridge power circuits.

Each chipset consists of a pair of DIP ICs interconnected by two TX02-4400 signal pulse transformers. Proprietary voltage translation techniques permit the transmission of ground (0-Volt) referenced gate-control signals for both the upper half of the phase leg with its high-side floating source/emitter, and to the 0-Volt referenced low-side.

Type	Description	Package	Temperature range	Outlines P. 188-224
IXBD4410PI IXBD4411PI	Full-Feature Low-Side Driver Full-Feature High-Side Driver	16-Pin P-DIP 16-Pin P-DIP	-40 to +85°C -40 to +85°C	X530
IXBD4410SI IXBD4411SI	Full-Feature Low-Side Driver Full-Feature High-Side Driver	16-Pin SOP 16-Pin SOP	-40 to +85°C -40 to +85°C	X531
TX02-4400JI TX02-4400PI	Isolation transformer Isolation transformer	8-Pin P-DIP-SM 8-Pin P-DIP	-55 to -125°C	X502 X500

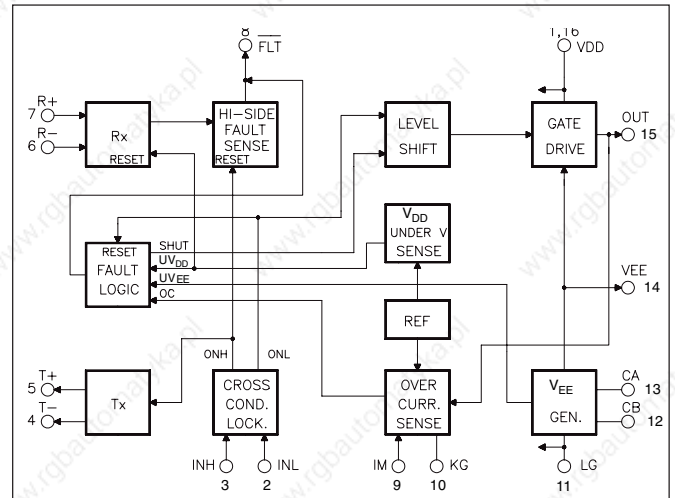

Block diagram IXBD4410

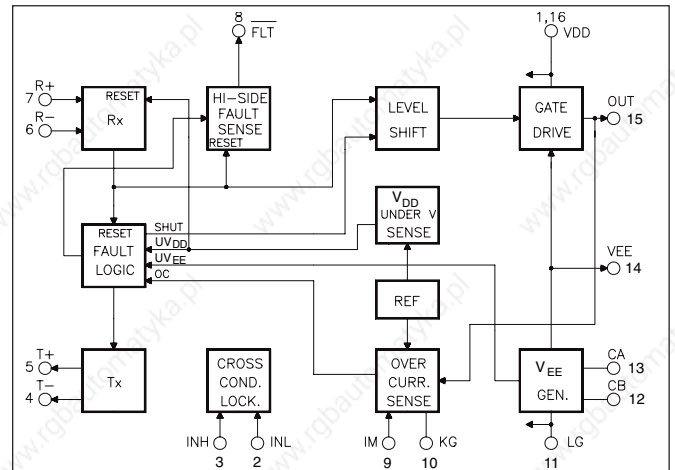

Block diagram IXBD4411

The chipset is noise immunized to commutation dv/dts of 50 V/ns between the two halves. The IXBD4410/11 outputs an on-chip generated negative gate voltage to inhibit possible Miller-induced IGBT turn on created by free-wheel diode commutations. This version also features a 0-Volt referenced fault-signal flag monitoring both high and low side drivers for sophisticated system protection. Both models incorporate shut-down circuitry to disable gate driver signals when an overcurrent is detected, either through desaturation of the driven power switch or by direct measurement of the switch current. Simultaneous conduction of upper and lower signal input logic. C-MOS technology reduces stand-by currents drawn from the single external power supply to low levels, and chipset operation to over 20 kHz is possible. The EVBD4400 evaluation board is also available to facilitate design-in activity.

Gate Drive Evaluation Boards

MOSFET/IGBT Gate Drive Modules/Gate Drive IC Evaluation Boards

The EV-Series MOSFET Gate Drive Modules are general purpose gate drive circuits designed to drive the DE-Series RF POWER MOSFETs, as well as industry-standard MOSFETs and IGBTs. Designed using IXYS/DEI gate drive ICs, they serve as a system development tool for the design engineer, and as a convenient platform for the evaluation of the DE-Series RF MOSFET transistors. The EVDD415 and EVIC420 are designed to drive DE-Series RF MOSFETs. The EVDI402, EVDD404, EVDD409, EVDI409 and EVDD414 gate drive modules are designed to drive MOSFETs or IGBTs in various package types, including TO-220, TO-247, TO-264 or SOT-227 packages.

The evaluation board design allows the MOSFET or IGBT to be attached to a heat sink, and in so doing the board assembly can be used as a ground referenced, low side power switch for both single-ended and push-pull configurations. They may be used as pulse width agile, high power switching modules in pulse generators, RF generators, pulsed laser diode drivers and other high voltage, high speed applications.

By utilizing design techniques developed by DEI, the EVDD 415 and EVIC 420 gate drive modules can drive DE-Series MOSFET transistors at frequencies up to 45 MHz, provide continuously variable output pulse widths from ~5ns to DC, and rise times of <3ns (actual performance is dependent upon the specific gate drive module and the MOSFET device used).

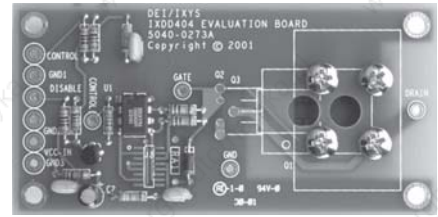

EVDD404 with IXDD404PI *



EVDD409 with IXDD409YI *

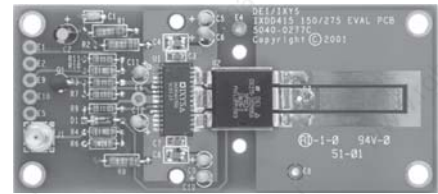

EVDD415 with IXDD415SI *

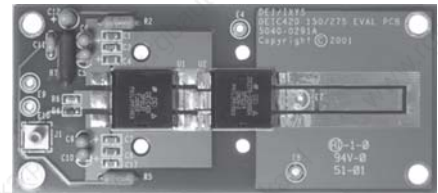

EVIC420A with DEIC420 *

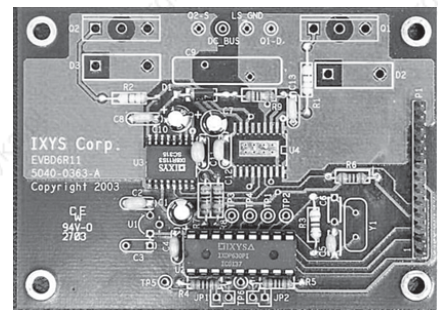

EV6R11 with IX6R11S3 *

Gate Drive Module/Evaluation Board Selection Guide

Gate Drive Module	Installed Device	Connectable Package *
EVDD430CI	IXDD430CI	TO-247, TO-268, SOT-227
EVDD430MCI	IXDD430MCI	TO-247, TO-268, SOT-227
EVDD430YI	IXDD430YI	TO-247, TO-268, SOT-227
EVDD430MYI	IXDD430MYI	TO-247, TO-268, SOT-227
EVDI430CI	IXDI430CI	TO-247, TO-268, SOT-227
EVDI430MCI	IXDI430MCI	TO-247, TO-268, SOT-227
EVDI430YI	IXDI430YI	TO-247, TO-268, SOT-227
EVDI430MYI	IXDI430MYI	TO-247, TO-268, SOT-227
EVDN430CI	IXDN430CI	TO-247, TO-268, SOT-227
EVDN430MCI	IXDN430MCI	TO-247, TO-268, SOT-227
EVDN430YI	IXDN430YI	TO-247, TO-268, SOT-227
EVDN430MYI	IXDN430MYI	TO-247, TO-268, SOT-227
EVDS430SI	IXDS430SI	TO-247, TO-268, SOT-227
EVBD4400	IXBD4400 Chip Set	TO-247, TO-264
EVDI402	IXDI402PI	TO-220, TO-247, TO-264, SOT-227
EVDN402	IXDN402PI	TO-220, TO-247, TO-264, SOT-227
EVDD404	IXDD404PI	TO-220, TO-247, TO-264, SOT-227
EVDI404	IXDI404PI	TO-220, TO-247, TO-264, SOT-227
EVDN404	IXDN404PI	TO-220, TO-247, TO-264, SOT-227
EVDI409	IXDI409YI	TO-220, TO-247, TO-264, SOT-227
EVDN409	IXDN409YI	TO-220, TO-247, TO-264, SOT-227
EVDD414	IXDD414YI	TO-220, TO-247, TO-264, SOT-227
EVDI414	IXDI414YI	TO-220, TO-247, TO-264, SOT-227
EVDN414	IXDN414YI	TO-220, TO-247, TO-264, SOT-227
EVDD415	IXDD415SI	DEI DE-150, DEI DE-275
EVIC420A	DEIC420	DEI DE-150, DEI DE-275
EVIC420B	DEIC420	DEI DE-375, DEI DE-475
EV6R11S3	IX6R11S3	TO-247, TO-264
EV6R11S7	IX6R11S7	TO-247, TO-264

* Connectable Power MOSFET or IGBT is not included

Integrated Circuits

High Voltage Current Regulators

Features

- Extremely stable current characteristics 50 ppm/K
- Minimum of 450 V breakdown
- 40 W continuous dissipation

Applications

- Start-up circuits for SMPS
- PABX current sources
- Telephone line terminations
- Surge limiters and protection
- Waveform synthesizers
- Soft start-up circuits

Non-switchable Regulators



This is a family of extremely stable, 450 Volt (min.) current regulators. Temperature stability is based on a threshold compensation technique and uses IXYS' most recently developed high voltage process. Some specific applications include PABX current sources and line terminations, high stability voltage sources, surge limiters, fast reacting non-destruct fuses and start-up circuits. These regulators also replace power resistors in house-keeping supplies derived from the AC mains, dramatically reducing power consumption while permitting universal use from 110-240 V AC without part changes.

Switchable Regulators

The **IXCP10M45S** is an enhanced version of IXYS' family of high voltage current regulators. It is similar in all respects to the standard product, except that it can be switched off by applying a negative voltage to its control pin. Minimum breakdown voltage is increased to 450 V. For additional versatility, output current may be programmed by inserting a resistor between the negative output and control pins. A prime application to the switchable regulator is in house-keeping power supplies for switch-mode-power-supplies (SMPS), where shutting the regulator down once the SMPS is up and running reduces standby power consumption virtually to zero.

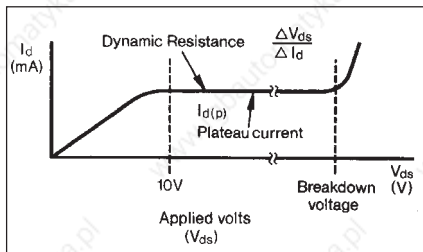
Characteristic

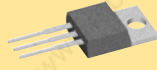

Current regulator	BV_{DS} min. V	$I_{D(P)}$ typ. mA	X005a TO-220 AB 	X004 TO-252 AA 
DC Non-switchable	450	60	IXCP60M45	IXCY60M45
		50	IXCP50M45	IXCY50M45
		40	IXCP40M45	IXCY30M45
		20	IXCP20M45	IXCY20M45
		11	IXCP10M45	IXCY10M45
		2.2	IXCP02M45	IXCY02M45
Switchable	450	10	IXCP10M45S	IXCY10M45S
Gate Controlled	900	10	IXCP10M90S	IXCY10M90S

Outline drawings on page 188 - 224

Bus compatible Digital PWM Controller, IXDP610

Features

- Microcomputer bus compatible
- Two complementary outputs for direct control of switching power bridge
- Dynamically programmable pulse width ranges from 0 to 100%
- Two modules of operation: 7-bit or 8-bit resolution
- Switching frequency range up to 300 kHz
- Programmable Dead-time Counter prevents switching overlap
- Cycle-by-cycle disable input to protect against over-current, over-temperature, etc.
- Outputs may be disabled under software control
- Special locking bit prevents damage to the power stage in the event of a software failure

The IXDP610 Digital Pulse Width Modulator (DPWM) is a programmable CMOS LSI device which accepts digital pulse width data from a microprocessor and generates two complementary non-overlapping pulse width modulated signals for direct digital control of a switching power bridge. The DPWM is designed to be operated under the direct

Basis system Configuration

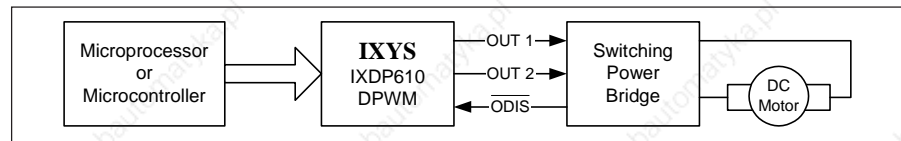

control of a microprocessor and interfaces easily with most standard microprocessor and microcomputer buses. The PWM waveform generated by the IXDP610 results from comparing the output of the Pulse Width Counter to the number stored in the Pulse Width Latch. A programmable 'dead-time' is incorporated into the PWM waveform. The Dead-time Logic disables both outputs on each transition of the Comparator output for the required dead-time interval. The output stage provides complementary PWM output signals capable of sinking and sourcing 20 mA at TTL voltage levels. The Output Disable Logic can be activated either by software or hardware. The facilitates cycle-by-cycle current-limit, short-circuit, overtemperature, and desaturation protection

schemes. The IXDP610 is capable of operating at PWM frequencies from zero to 300 kHz, the dead-time is programmable from zero to 14 clock cycles (0 to 11 % of the PWM cycle), which allows operation with fast power MOSFETs, MOSIGBTs, and bipolar power transistors. A trade-off between PWM frequency and resolution is provided by selecting the counter resolution to be 7-bit or 8-bit. The 20 mA output drive makes the IXDP610 capable of directly driving opto isolators and Smart-power devices. The fast response to pulse width commands is achieved by instantaneous change of the outputs to correspond to the new command. This eliminates the one-cycle delay usually associated with digital PWM implementations.

Type	Package	Temperature Range °C	Outline drawings on page 188-224
IXDP610PI	18-Pin P-DIP	-40 to 85	X540

Digital Deadtime Generator, IXDP630 / 631

Features

- 5 Volt HCMOS logic implementation maintains low power at high speed
- Schmitt trigger inputs and CMOS logic levels improve noise immunity
- Simultaneously injects equal deadtime in up to three output phases
- Replaces 10-12 standard SSI/MSI logic devices
- Allows a wide range of PWM modulation strategies
- Directly drives high speed optocouplers

This 5 Volt HCMOS integrated circuit is intended primarily for application in three-phase sinusoidally commutated brushless motor, induction motor, AC servomotor or UPS PWM modulator control systems. It injects the required deadtime to convert a single phase leg PWM command the two separate logic signals required to drive the upper and lower semiconductor switches in a PWM inverter. It also provides facilities for output disable, fast overcurrent, and fault condition shutdown.

In the IXDP630 the dead time is set by controlling frequency of the internal oscillator using an external R.C. network. In the IXDP631 the dead time is achieved by use of an external crystal oscillator. An alternative programming means for both the IXDP630/631 is by an externally provided clock signal. Because of its flexibility, the IXDP630/631 is easily utilized in a variety of brushed DC, trapezoidally commutated brushless DC, hybrid and VR step, or other more exotic PWM motor drive power and control circuit designs.

Type	Configuration	Package	Temperature Range °C	Outline drawings on page 188-224
IXDP630PI	RC Oscillator	18-Pin P-DIP	-40 to 85	X540
IXDP631PI	Crystal Oscillator	18-Pin P-DIP	-40 to 85	X540

Integrated Circuits

IXS839 / IXS839A / IXS839B

Synchronous Buck MOSFET Driver

(MOSFET Driver for High Efficiency DC to DC Power Converter Applications)

The IXS839/IXS839A/IXS839B are 2 A source / 4 A sink synchronous buck MOSFET drivers. These synchronous buck MOSFET drivers are specifically designed to drive two N-channel power MOSFETs in a synchronous buck converter. The high side driver is powered via a bootstrapped power connection. The driver is capable of 20 ns high-side output, and 18 ns low-side output transition times driving a 3000 pF load. The IXS839 and IXS839B incorporate an under voltage lockout to prevent unintentional gate drive output during low voltage conditions. The IXS839A/B includes external shutdown and low-side drive shutdown features.

Simultaneous shutdown of both outputs prevents rapid output capacitor discharge. The high-side turn-on delay is adjustable with an external capacitor added at the DLY pin. The IXS839/839A/839B are designed to operate over a temperature range of -40°C to +85°C. The IXS839 is available in an 8-lead SOIC, the IXS839A and the IXS839B in a 10-pin QFN.

Features

- Logic level gate drive compatible
- 2 A Source, 4A sink peak drive current
- Programmable high-side driver turn-on delay

- Supports floating voltage for top driver up to 24 V
- IXS839/839B: under voltage sockout
- IXS839A/B: output shutdown, low side shutdown inputs
- 10 μ A shut down current
- 2 mA quiescent current (non-switching)
- Bootstrapped high side driver
- Cross-conduction protection

Applications

- Multiphase desktop CPU supplies
- Mobile CPU core voltage supplies
- High current / low voltage DC/DC synchronous Buck Converters

Synchronous Buck Gate

Part Number	Analog Supply Voltage V	I _{PK} Source A	I _{PK} Sink A	Floating Supply Voltage V	Under Voltage Lockout	Shutdown	Protection Features	Delay	Package	Fig. No.
► New										
► IXS839S1	5.5	2	4	24	Yes		Over Lap, Cross Conduction Protection	Programmable High-Side Driver Turn-on Delay	8-Pin SOP	X501
► IXS839AQ2	5.5	2	4	24		Driver Shutdown & Low Side Shutdown			10-Pin QFN	X510
► IXS839BQ2	5.5	2	4	24	Yes				10-Pin QFN	X510

Outline drawings on page 188 - 224

MX841

White LED Step-Up Converter

The MX841 is a fixed frequency, constant current source step-up DC/DC converter. The output current is directly regulated making the MX841 ideal for driving series connected white light emitting diodes (LED's) in backlight applications. The MX841 powers up to 3 series white LED's at 1.1V, and 20 series/parallel white LED's at 5.0V. The MX841 features a 1.0MHz switching frequency to accommodate the use of small capacitors and a small inductors necessary in size sensitive portable

applications. Light intensity and shutdown are conveniently controlled by a single analog voltage. Power efficiency and battery life are extended through the use of a high voltage, low R_{DS(ON)} N-channel MOSFET switch. The MX841 is designed to operate over a temperature range of -40°C to +85°C, and is available in an SOIC-8 Package, with or without an Exposed Pad in Tube or on Tape and Reel. (Alternate package types available upon request).

Features

- 1.1 V to 5.5 V Input Range
- 2 Amp Peak Switch Current
- High Efficiency > 80%
- 20 V Maximum Output with Over-Voltage Protection
- LED Intensity Control
- 1.0 MHz Fixed Frequency Switching
- 8 Lead SOIC Package

Applications

- White LED Display Backlighting
 - Low Voltage: Mobile Phones, PDA's, MP3 Players, Digital Cameras
 - High Drive Current: Vehicle Instrumentation Panels

LED Driver

Part Number	Supply Voltage max V	Switch Current Peak A	f _{osc} typ MHz	Duty Cycle max %	Switching Voltage Range V _{DD} - V _{SCHOTTKY} V	Package	Fig. No.
► New							
► MX841	5.5	2	1	72.5	20	8-Pin SOP	X501

Integrated Circuits

IXI858 / IXI859

Gate Driver with VReg and Charge Pump Regulator

The IXI858 and IXI859 Gate Driver / Regulator ICs are part of IXYS growing family of interface products. These ICs are designed to provide the needed analog functions required by microcontrollers to implement offline digital power supply control, such as in Power Factor Correction (PFC).

The IXI858 / 859 combine a power gate drive, low voltage linear regulator and a charge pump function for drive voltage generation as needed in these applications. These features make the IXI858 / 859 invaluable for implementing microcontroller based PFC systems. The IXI858/859 can be used in combination with a Depletion-Mode Power MOSFET such as IXTY02N50D, which can be used to create a constant current source to provide offline standby power at lower cost with lower high line power consumption.

The IXI858 is designed to support 5.0V digital systems with an on board 5.0V linear regulator, while the IXI859 features a 3.3V linear regulator for lower voltage systems. In addition, both versions feature logic level input signal compatibility, 60mA source and 120mA sink gate drive output and a charge pump section meant to generate 13V gate drive voltage.

The growing trend of digital power management, with the use of standard microcontroller in motor control, power supply, and PFC circuits require the interface, voltage gain and drive of the IXI858/859 for the digital power management. The IXI858/ 859 were optimized for cost and efficiency to support high volume applications such as dimmable ballast, non-dimmable ballast and High Intensity Discharge

(HID) lighting systems. The IXI858/859 are offered in a small 8-Lead SOIC surface mount package, with rated operation of -25°C to $+125^{\circ}\text{C}$.

Features

- Logic Level Gate Drive Compatible
- 60 mA Source / 120 mA Sink Minimum Gate Drive
- 5.0 V or 3.3 V Voltage Regulator
- Charge Pump Regulator Stabilizes VCC Power Supply at 13 V
- UVLO Protection

Applications

- μ Controller based off-line applications

Gate Driver With Vreg

Part Number	V _{CC} max	I _{peak} +/-	V _{in} max	V _{out} , R _{reg.} max	V _{CPRon} Turn-on Level	V _{CPRoff} Turn-off Level	I _{SINK} , min V _{gate} = 6 V	I _{SRC} , min V _{gate} = 3 V	t _{MINPW} C _{gate} = 10pF	t _{PD} C _{gate} = 10pF	Package	Fig. No.
> New	V	A	V	V	V	V	mA	mA	ns	ns		
> IXI858S1	20	1	6	3.3	13.15	12.85	120	60	80	200	8-Pin SOP	X501
> IXI859S1	20	1	6	5	13.15	12.85	120	60	80	200	8-Pin SOP	X501

Outline drawings on page 188 - 224

IXI848/IXI848A

High-Side Current Monitor

The IXI848/IXI848A is precision high side current sense monitor. High side power-line monitoring offers the advantage of allowing the ground plane to remain undisturbed when sensing load currents.

An external sense resistor sets the range of the amplified ground-referenced output monitoring voltage. The output voltage is amplified by a

selectable fixed gain of either 10 or 50. With an input voltage range up to 40V for IXI848 and 60V for IXI848A, and output gain of up to 50, the IXI848/IXI848A are designed to address a wide variety of current sense applications.

The IXI848/IXI848A operates over a temperature range of -40°C to $+85^{\circ}\text{C}$. The IXI848/IXI848A are available in an 8-Lead SOIC package.

Features

- High-Side Current Sense Amplifier
- IXI848: 2.7 V to 40 V Input Range
- IXI848A: 2.7 V to 60 V Input Range
- 0.7% Typical Full Scale Accuracy
- Scalable Output Voltage
- SOIC Package

Applications

- Power Management Systems
- Smart Battery Packs
- Battery Chargers
- Battery Powered Portable Equipment
- DC Motor Control

High-Side Current Monitor

Part Number	V _{IN} max	I _{IN} max	V _{SENSE} typ	Full Scale Accuracy	Input Offset Voltage, typ.	Gain Accuracy	Temp Range min	Temp Range max	Package	Fig. No.
> New	V	mA	mV	%	V	%	$^{\circ}\text{C}$	$^{\circ}\text{C}$		
> IXI848S1	40	0.13	150	± 0.7	± 0.5	± 0.5	-40	85	8-Pin SOP	X501
> IXI848AS1	60	0.13	150	± 0.7	± 0.5	± 0.5	-40	85	8-Pin SOP	X501

Power Semiconductor Chips

IXYS offers a wide range of dice for a multitude of applications.

IGBT Chips	V_{CES}	I_C	$V_{CE(sat)}$
G series, Low $V_{CE(sat)}$ type	300 - 1200 V	10 - 60 A	1.6 - 3.5 V
G series, High Speed type	300 - 1200 V	10 - 100 A	2.5 - 4.0 V
S series, Low $V_{CE(sat)}$ type	600 - 1200 V	20 - 45 A	2.5 - 3.5 V
S series, High Speed type	600 - 1400 V	20 - 40 A	2.7 - 4.0 V
MOSFET Chips	V_{DSS}	$R_{DS(on)}$	t_{rr}
HiPerFET™ Power MOSFET	70 - 1200 V	0.005 - 4.5 Ω	150 - 250 ns
Standard Power MOSFET	55 - 1100 V	0.013 - 4.5 Ω	-
Fast Recovery Diodes, Rectifier Diodes and Thyristor Chips in Planar Design			
Bipolar Chips	V_{RRM} / V_{DRM}	$I_{F(AV)M} / I_{T(AV)M}$	t_{rr}
Ultrafast FRED Chips	200 - 1200 V	8 - 162 A	35 - 50 ns
Low Leakage ultrafast FRED Chips	200 - 1200 V	15 - 143 A	-
Fast Recovery Diode Chips	1200 - 1600 V	17 - 48 A	1.5 ns
Rectifier Diodes	1200 - 1800 V	15 - 400 A	-
Phase Control Thyristors	800 - 2200 V	19 - 250 A	-
Schottky Diodes	8 - 180 V	10 - 200 A	-
GaAs Diodes		Contact Factory	
Silicon Chip Resistors	1 - 10 Ω		
Sonic Fast Recovery Diode Chips	600 - 1800 V	15 - 90 A	tbd

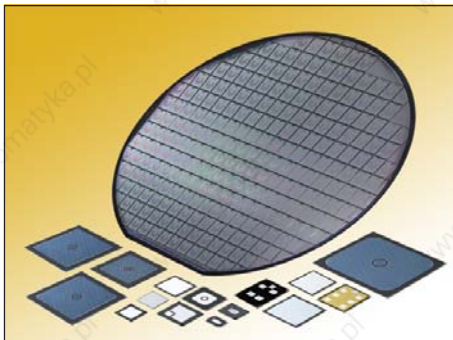

The most important features of planar technology are:

- no PN junction termination in the underside or to the edges; thus non-critical handling and simplified mounting
- fabricated using isolation diffusion with guard rings, channel stoppers and thick glass passivation to assure high electrical reliability and stability
- important electrical parameters 100% tested on the chips
- thyristor chips with center or corner gate construction
- chips with solderable or bondable metallization
- new standard 125 mm (5 inch) diameter wafers

IXYS can ship chips as follows:

- Chips in wafer form, unsawed, electrically tested, rejects are inked
- Chips in sawed wafer on foil, electrically tested, rejects are inked
- Chips in tray (Waffle Pack), electrically tested

IXOLAR™ High Efficiency Solar Cells

Technical Information

Description

IXOLAR™ Solar Cells are IXYS' monocrystalline, high efficiency solar cell technology products incorporating an enhanced light trapping surface. There are 6 different cell sizes available: 36 mm², 72 mm², 120 mm², 240 mm², 360 mm² and 480 mm².

The IXOLAR™ Solar Cells are ideal for charging various battery powered and handheld consumer products such as mobile phones, cameras, PDAs, MP3-Players and toys. They are also suitable for industrial applications such as wireless sensors, portable instrumentation and for charging emergency backup batteries.

With an efficiency of typically 17%, these solar cells give the ability to extend run time even in „low light“ conditions and increase battery life and run time in a small footprint, which can be easily accommodated in the design of Portable Products.

IXOLAR products have a very good response over a wide wavelength range and therefore can be used in both indoor and outdoor applications.

Product and Ordering Information

Part Number	X [mm]	Y [mm]	Open Circuit Voltage [mV]	Short Circuit Current [mA]
XOD17-04B	6	6	630	12
XOD17-07B	12	6	630	24
XOD17-12B	6	20	630	42
XOD17-24B	12	20	630	84
XOD17-36B	18	20	630	126
XOD17-48B	24	20	630	168

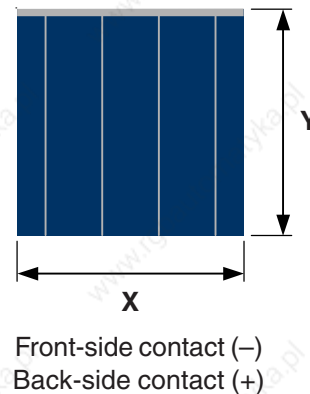

Electrical Characteristics

Symbol	Cell Parameter	Typical Ratings *)	Units
V_{OC}	open circuit voltage	630	mV
J_{SC}	short circuit current density	35	mA/cm ²
V_{mpp}	voltage at max. power point	505	mV
J_{mpp}	current density at max. power point	32.5	mA/cm ²
P_{mpp}	maximum peak power	16.6	mW/cm ²
FF	fill factor	> 75	%
ζ	efficiency	17	%
$\Delta V_{OC}/\Delta T$	open circuit voltage temp. coefficient	-2.1	mV/K
$\Delta J_{SC}/\Delta T$	short circuit current temp. coefficient	0.12	mA/(cm ² K)
t	cell thickness	250	μ m

Features

- Monocrystalline silicon technology
- High efficiency
- Enhanced light trapping surface texturization

Applications

- Battery chargers for portables such as cell phones, PDAs, GPS-Systems, ...
- „Green“ electricity generation
- Power backup for UPS, Sensors, Wearables

Advantages

- Long life and stable output
- Solderable back-side metallization
- Bondable front-side metallization
- Available in die and wafer form

*) All values measured at Standard Condition:
1 sun (= 100 mW/cm²), Air Mass 1.5, 25°C

IXOLAR™ High Efficiency Solar Bits

Description

IXOLAR™ Solar Bits are IXYS' product line of coated monocrystalline, high efficiency solar cell products using IXYS' XOD17 bondable solar cell dies. Solar Bits have reflow solderable surface mount packages, they are available in tape and reel packages and can be automatically pick and place mounted. There are 2 different Solar Bits available with different voltage and current output.

The IXOLAR™ Solar Bits are ideal for charging various battery powered and handheld consumer products such as mobile phones, cameras, PDAs, MP3-Players and toys. They are also suitable for industrial applications such as wireless sensors, portable instrumentation and for charging emergency backup batteries.

With a cell efficiency of typically 17%, Solar Bits give the ability to extend run time even in „low light“ conditions and increase battery life and run time in a small footprint, which can be easily accommodated in the design of Portable Products. The design allows to flexibly connect Solar Bits in series and/or parallel to perfectly meet the application's power requirements.

IXOLAR products have a very good response over a wide wavelength range and therefore can be used in both indoor and outdoor applications.

Product and Ordering Information

Part Number	Open Circuit Voltage [V]	Short Circuit Current [mA]	Typ. Voltage @ P _{mpp} [V]	Typ. Current @ P _{mpp} [mA]
▶ XOB17-12 x 1	0.63	42.0	0.51	39.0
▶ XOB17-04 x 3	1.89	12.6	1.53	11.7

(all parameters given are typical values)

Dimensions (L x W x H): 22 x 7 x 1.4 [mm]

Solar Bit Weight: 0.5 grams

Solar Bits are compliant to the RoHS Norm.

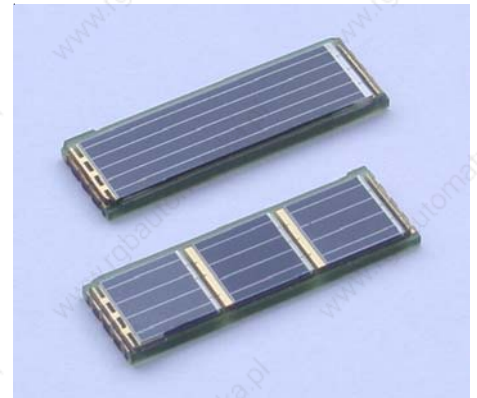

Solar Cell Electrical Characteristics

Symbol	Cell Parameter	Typical Ratings *)	Units
V _{oc}	open circuit voltage	630	mV
J _{sc}	short circuit current density	35	mA/cm ²
V _{mpp}	voltage at max. power point	505	mV
J _{mpp}	current density at max. power point	32.5	mA/cm ²
P _{mpp}	maximum peak power	16.6	mW/cm ²
FF	fill factor	> 75	%
η	efficiency	17	%
ΔV _{oc} /ΔT	open circuit voltage temp. coefficient	-2.1	mV/K
ΔJ _{sc} /ΔT	short circuit current temp. coefficient	0.12	mA/(cm ² K)

*) All values measured at Standard Condition: 1 sun (= 1000 W/m²), Air Mass 1.5, 25°C



Features

- Monocrystalline silicon technology
- High efficiency outdoor and indoor
- Long life and stable output
- Sealed Package
- Surface Mount Package
- Reflow Solderable
- Very high mechanical robustness

Applications

- Battery chargers for portables such as cell phones, PDAs, GPS-Systems, ...
- „Green“ electricity generation
- Power backup for UPS, Sensors, Wearables

Advantages

- Automatic Pick & Place Mounting
- One Product for Multiple Applications
- Flexible Integration into the Application

Direct Copper Bonded Ceramic Substrates

DCB and DAB Ceramic Substrates (Al₂O₃ or AlN)

IXYS manufactures Direct Copper Bonded substrates on aluminum oxide (Al₂O₃) or aluminum nitride (AlN) base. DCB ceramic substrates form the basis for new product ideas and electronic developments with a high degree of integration.

Standard bonded DCB panel dimensions are:

Unclad aluminum oxide ceramic			
Al ₂ O ₃ content		> 96	%
dimensions		138 x 190.5, 115 x 165*	mm
usable area	max.	130 x 180, 107 x 156*	mm
thickness		1.00, 0.63, 0.38, 0.25	mm
arc through voltage		10	kV
thermal conductivity		> 24	W/m · K
Conduction layers - both sides			
copper thickness		0.3 (< 0.3 on request)	mm
conductor width	min.	0.3 + / - 0.2	mm
conductor spacing	min.	0.4 + / - 0.2	mm
spacing conductor/edge of ceramic	min.	0.35 + / - 0.2	mm
surface finishes available		bare copper; nickel plated; nickel + gold plated	
peel-off resistance (DIN 532282)	min.	9	N/mm
DCB ceramic substrate			
application temperature range		-55...+850	°C
resistant to hydrogen	max. up to	400	°C
thermal expansion coefficient	typical	7.4 x 10 ⁻⁶	K ⁻¹
dimensions according to customer specific drawing			

DCB parts are available as:

- bonded plate
- bonded and patterned plate
- prelasered, unbroken plate
- individuale substrates

ALN - DCB on request

* = (for 0.25 mm thk.)

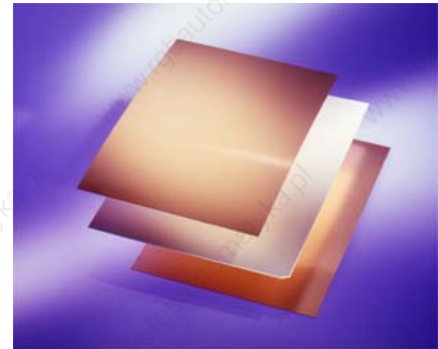

Patterned DCB substrates can be manufactured to customers' drawings.

DCB ceramic substrates fulfill several functions:

- carriers for the semiconductor chips and connection clips
- circuits similar to that on a PC board
- electrical isolator for separating the "current paths" from the "heat paths"
- transfer medium for the heat dissipation from the active parts into the heat sink.

Available from www.westcode.com

- Application dependent gate trigger requirements of GTO thyristors
- The implementation of gate turn-off thyristors as high voltage turn-on switches for pulse power applications
- Improved semiconductor switches for pulse power applications
- Integrated 30kV Solid-State Switch for Pulse Power Applications
- Press-Pack IGBTs, Semiconductor Switches for Pulse Power
- The application of pressure contact IGBTs in pulse power
- Design concepts of a bondless pressure-contact IGBT
- Electromechanical characteristics of a bondless pressure contact IGBT
- Pressure Contacted IGBTs
- Pressure contact IGBT, the ideal switch for high power applications
- Pressure contact IGBT, testing for reliability
- New high current press-pack IGBTs
- Magazine Feature: Positive Development in high reliability completely bond free pressure contact IGBTs
- Application of Press-pack IGBTs in Traction Refurbishment
- New 5.2kV Extra Fast Recovery Diodes for IGBT and IGCT Applications
- New family of 4.5kV Press-Pack IGBTs
- New Extra Fast Soft Recovery Diodes and their Applications
- Managing power semiconductor obsolescence by press-pack IGBT substitution
- Westcode Product Nomenclatures (Capsules, Studs, and Pulse Thyristors)
- Terms & Symbols
- Mounting Instructions
- Press Releases











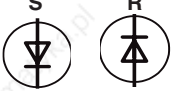

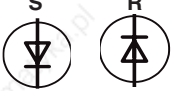

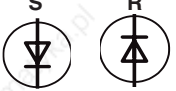

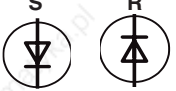

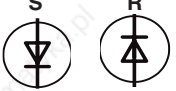

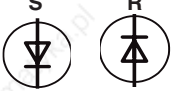

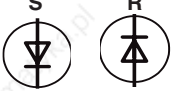

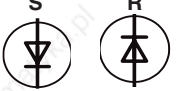

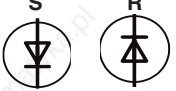

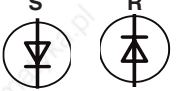

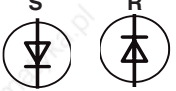

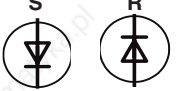

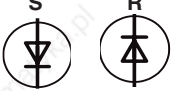

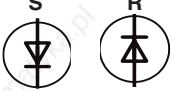

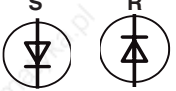

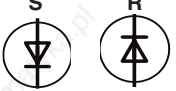
Our comprehensive range of rectifier diodes offers class leading performance and reliability. Devices with blocking voltages from 200V up to 6kV and average current ratings up to 8405A, T_k 55°C.

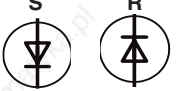
Optimised to offer low conduction losses, these devices are ideally suited to line frequency applications including input

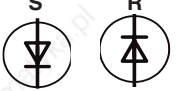
rectifiers for variable speed drives, traction converters, trackside substations, welding and DC power supplies.

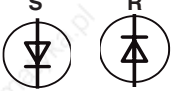
Utilising compression bonded, alloyed Silicon wafer construction, these devices feature low thermal impedance and high overload capacity and are designed to survive even the most arduous applications.

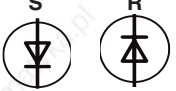
Rectifier Diodes - Stud Types

Type		V_{RRM}	I_{FAV} $T_k=55^\circ\text{C}$	I_{FSM} 10ms 1/2 sine $V_R \leq 60\% V_{RRM}$	I^2t $VR \leq 60\%$ V_{RRM} A^2s	V_{TO} @ T_j max	r_T	T_j max	R_{thJC}		Fig. No.	Package style
Part No.	Old part No.	V	A	A		V	mΩ	°C	d.c. 180° sine K/W	120° Rect. K/W		Outline drawings on pages 188 - 224
W0508SA040	SW04PHN300	400	508	5500	151×10^3	0.95	0.75	180	0.13	0.14	W23	   Fig. W23 Weight 250 g
W0508SA120	SW12PHN300	1200	508	5500	151×10^3	0.95	0.75	180	0.13	0.14	W23	
W0508SA150	SW15PHN300	1500	508	5500	151×10^3	0.95	0.75	180	0.13	0.14	W23	
W0508RA040	SW04PHR300	400	508	5500	151×10^3	0.95	0.75	180	0.13	0.14	W23	   Fig. W23 Weight 250 g
W0508RA120	SW12PHR300	1200	508	5500	151×10^3	0.95	0.75	180	0.13	0.14	W23	
W0508RA150	SW15PHR300	1500	508	5500	151×10^3	0.95	0.75	180	0.13	0.14	W23	
W0508SB040	SW04HHN300	400	508	5500	151×10^3	0.95	0.75	180	0.13	0.14	W27	   Fig. W23 Weight 250 g
W0508SB120	SW12HHN300	1200	508	5500	151×10^3	0.95	0.75	180	0.13	0.14	W27	
W0508SB150	SW15HHN300	1500	508	5500	151×10^3	0.95	0.75	180	0.13	0.14	W27	
W0508RB040	SW04HHR300	400	508	5500	151×10^3	0.95	0.75	180	0.13	0.14	W27	   Fig. W23 Weight 250 g
W0508RB120	SW12HHR300	1200	508	5500	151×10^3	0.95	0.75	180	0.13	0.14	W27	
W0508RB150	SW15HHR300	1500	508	5500	151×10^3	0.95	0.75	180	0.13	0.14	W27	
W0438SC160	SW16PHN320	1600	438	4000	80×10^3	1.00	0.83	180	0.15	0.16	W24	   Fig. W24 Weight 250 g
W0438SC200	SW20PHN320	2000	438	4000	80×10^3	1.00	0.83	180	0.15	0.16	W24	
W0438SC240	SW24PHN320	2400	438	4000	80×10^3	1.00	0.83	180	0.15	0.16	W24	
W0438RC160	SW16PHR320	1600	438	4000	80×10^3	1.00	0.83	180	0.15	0.16	W24	   Fig. W24 Weight 250 g
W0438RC200	SW20PHR320	2000	438	4000	80×10^3	1.00	0.83	180	0.15	0.16	W24	
W0438RC240	SW24PHR320	2400	438	4000	80×10^3	1.00	0.83	180	0.15	0.16	W24	
W0438SD160	SW16HHN320	1600	438	4000	80×10^3	1.00	0.83	180	0.15	0.16	W26	   Fig. W24 Weight 250 g
W0438SD200	SW20HHN320	2000	438	4000	80×10^3	1.00	0.83	180	0.15	0.16	W26	
W0438SD240	SW24HHN320	2400	438	4000	80×10^3	1.00	0.83	180	0.15	0.16	W26	
W0438RD160	SW16HHR320	1600	438	4000	80×10^3	1.00	0.83	180	0.15	0.16	W26	   Fig. W24 Weight 250 g
W0438RD200	SW20HHR320	2000	438	4000	80×10^3	1.00	0.83	180	0.15	0.16	W26	
W0438RD240	SW24HHR320	2400	438	4000	80×10^3	1.00	0.83	180	0.15	0.16	W26	
W0503SC160	SW16PHN380	1600	503	5500	151×10^3	0.99	0.74	180	0.13	0.14	W24	   Fig. W26 Weight 200 g
W0503SC200	SW20PHN380	2000	503	5500	151×10^3	0.99	0.74	180	0.13	0.14	W24	
W0503SC240	SW24PHN380	2400	503	5500	151×10^3	0.99	0.74	180	0.13	0.14	W24	
W0503RC160	SW16PHR380	1600	503	5500	151×10^3	0.99	0.74	180	0.13	0.14	W24	   Fig. W26 Weight 200 g
W0503RC200	SW20PHR380	2000	503	5500	151×10^3	0.99	0.74	180	0.13	0.14	W24	
W0503RC240	SW24PHR380	2400	503	5500	151×10^3	0.99	0.74	180	0.13	0.14	W24	
W0503SD160	SW16HHN380	1600	503	5500	151×10^3	0.99	0.74	180	0.13	0.14	W26	   Fig. W26 Weight 200 g
W0503SD200	SW20HHN380	2000	503	5500	151×10^3	0.99	0.74	180	0.13	0.14	W26	
W0503SD240	SW24HHN380	2400	503	5500	151×10^3	0.99	0.74	180	0.13	0.14	W26	
W0503RD160	SW16HHR380	1600	503	5500	151×10^3	0.99	0.74	180	0.13	0.14	W26	   Fig. W26 Weight 200 g
W0503RD200	SW20HHR380	2000	503	5500	151×10^3	0.99	0.74	180	0.13	0.14	W26	
W0503RD240	SW24HHR380	2400	503	5500	151×10^3	0.99	0.74	180	0.13	0.14	W26	
W0628SA040	SW04PHN400	400	628	7500	280×10^3	0.80	0.55	190	0.13	0.14	W23	   Fig. W26 Weight 200 g
W0628SA120	SW12PHN400	1200	628	7500	280×10^3	0.80	0.55	190	0.13	0.14	W23	
W0628SA150	SW15PHN400	1500	628	7500	280×10^3	0.80	0.55	190	0.13	0.14	W23	
W0628RA040	SW04PHR400	400	628	7500	280×10^3	0.80	0.55	190	0.13	0.14	W23	   Fig. W26 Weight 200 g
W0628RA120	SW12PHR400	1200	628	7500	280×10^3	0.80	0.55	190	0.13	0.14	W23	
W0628RA150	SW15PHR400	1500	628	7500	280×10^3	0.80	0.55	190	0.13	0.14	W23	
W0628SB040	SW04HHN400	400	628	7500	280×10^3	0.80	0.55	190	0.13	0.14	W27	   Fig. W26 Weight 200 g
W0628SB120	SW12HHN400	1200	628	7500	280×10^3	0.80	0.55	190	0.13	0.14	W27	
W0628SB150	SW15HHN400	1500	628	7500	280×10^3	0.80	0.55	190	0.13	0.14	W27	
W0628RB040	SW04HHR400	400	628	7500	280×10^3	0.80	0.55	190	0.13	0.14	W27	   Fig. W26 Weight 200 g
W0628RB120	SW12HHR400	1200	628	7500	280×10^3	0.80	0.55	190	0.13	0.14	W27	
W0628RB150	SW15HHR400	1500	628	7500	280×10^3	0.80	0.55	190	0.13	0.14	W27	
W0735SA040	SW04PHN470	400	735	9000	405×10^3	0.79	0.342	190	0.13	0.14	W23	   Fig. W27 Weight 200 g
W0735SA120	SW12PHN470	1200	735	9000	405×10^3	0.79	0.342	190	0.13	0.14	W23	
W0735SA150	SW15PHN470	1500	735	9000	405×10^3	0.79	0.342	190	0.13	0.14	W23	
W0735RA040	SW04PHR470	400	735	9000	405×10^3	0.79	0.342	190	0.13	0.14	W23	   Fig. W27 Weight 200 g
W0735RA120	SW12PHR470	1200	735	9000	405×10^3	0.79	0.342	190	0.13	0.14	W23	
W0735RA150	SW15PHR470	1500	735	9000	405×10^3	0.79	0.342	190	0.13	0.14	W23	
W0735SB040	SW04HHN470	400	735	9000	405×10^3	0.79	0.342	190	0.13	0.14	W27	   Fig. W27 Weight 200 g
W0735SB120	SW12HHN470	1200	735	9000	405×10^3	0.79	0.342	190	0.13	0.14	W27	
W0735SB150	SW15HHN470	1500	735	9000	405×10^3	0.79	0.342	190	0.13	0.14	W27	
W0735RB040	SW04HHR470	400	735	9000	405×10^3	0.79	0.342	190	0.13	0.14	W27	   Fig. W27 Weight 200 g
W0735RB120	SW12HHR470	1200	735	9000	405×10^3	0.79	0.342	190	0.13	0.14	W27	
W0735RB150	SW15HHR470	1500	735	9000	405×10^3	0.79	0.342	190	0.13	0.14	W27	

Rectifier Diodes - Capsule Types

Type		V_{RRM}	I_{FAV} $T_K=55^\circ C$	I_{FSM} 10ms ½ sine $V_R \leq 60\% V_{RRM}$	I^2t $V_R \leq 60\%$ V_{RRM} A ² s	V_{T0} @ T_{jmax}	r_T	T_{jmax}	R_{thJK}		Fig. No.
Part No.	Old Part No.	V	A	A		V	mΩ	°C	180° Sine K/W	120° Rect. K/W	
W0507YH360	SW36HXC270	3600	507	7600	289×10^3	0.970	0.880	160	0.100	0.117	W3
W0507YH450	SW45HXC270	4500	507	7600	289×10^3	0.970	0.880	160	0.100	0.117	W3
W0614WC160	SW16CXC320	1600	614	4000	80×10^3	1.000	0.830	180	0.090	0.098	W1
W0614WC200	SW20CXC320	2000	614	4000	80×10^3	1.000	0.830	180	0.090	0.098	W1
W0614WC240	SW24CXC320	2400	614	4000	80×10^3	1.000	0.830	180	0.090	0.098	W1
W0642WC160	SW16CXC380	1600	642	5500	151×10^3	0.990	0.740	180	0.090	0.098	W1
W0642WC200	SW20CXC380	2000	642	5500	151×10^3	0.990	0.740	180	0.090	0.098	W1
W0642WC240	SW24CXC380	2400	642	5500	151×10^3	0.990	0.740	180	0.090	0.098	W1
W0646WC060	SW06CXC300	600	646	5500	151×10^3	0.950	0.750	180	0.090	0.098	W1
W0646WC120	SW12CXC300	1200	646	5500	151×10^3	0.950	0.750	180	0.090	0.098	W1
W0646WC150	SW15CXC300	1500	646	5500	151×10^3	0.950	0.750	180	0.090	0.098	W1
W0797WC040	SW04CXC400	400	797	7500	281×10^3	0.800	0.550	190	0.090	0.098	W1
W0797WC120	SW12CXC400	1200	797	7500	281×10^3	0.800	0.550	190	0.090	0.098	W1
W0797WC150	SW15CXC400	1500	797	7500	281×10^3	0.800	0.550	190	0.090	0.098	W1
W0944WC040	SW04CXC470	400	944	9000	405×10^3	0.790	0.342	190	0.090	0.098	W1
W0944WC120	SW12CXC470	1200	944	9000	405×10^3	0.790	0.342	190	0.090	0.098	W1
W0944WC150	SW15CXC470	1500	944	9000	405×10^3	0.790	0.342	190	0.090	0.098	W1
W1032LC500	SW50CXC350	5000	1032	7200	259×10^3	1.000	0.702	150	0.033	0.040	W4
W1032LC560	SW56CXC350	5600	1032	7200	259×10^3	1.000	0.702	150	0.033	0.040	W4
W1032LC600	n/a	6000	1032	7200	259×10^3	1.000	0.702	150	0.033	0.040	W4
W1074YC200	SW20CXC445	2000	1074	10800	583×10^3	0.920	0.390	160	0.050	0.061	W2
W1074YC320	SW32CXC445	3200	1074	10800	583×10^3	0.920	0.390	160	0.050	0.061	W2
W1074YH200	SW20CXC445	2000	1074	10800	583×10^3	0.920	0.390	160	0.050	0.061	W3
W1074YH320	SW32CXC445	3200	1074	10800	583×10^3	0.920	0.390	160	0.050	0.061	W3
W1185LC300	SW30CXC515	3000	1185	9200	423×10^3	1.000	0.575	160	0.033	0.040	W4
W1185LC360	SW36CXC515	3600	1185	9200	423×10^3	1.000	0.575	160	0.033	0.040	W4
W1185LC450	SW45CXC515	4500	1185	9200	423×10^3	1.000	0.575	160	0.033	0.040	W4
W1263YC160	SW16CXC565	1600	1263	11700	684×10^3	0.870	0.330	175	0.050	0.061	W2
W1263YC250	SW25CXC565	2500	1263	11700	684×10^3	0.870	0.330	175	0.050	0.061	W2
W1263YH160	SW16CXC565	1600	1263	11700	684×10^3	0.870	0.330	175	0.050	0.061	W3
W1263YH250	SW25CXC565	2500	1263	11700	684×10^3	0.870	0.330	175	0.050	0.061	W3
W1294NC500	SW50CXC500	5000	1294	10000	500×10^3	1.150	0.684	150	0.022	0.026	W5
W1294NC600	SW60CXC500	6000	1294	10000	500×10^3	1.150	0.684	150	0.022	0.026	W5
W1411LC300	SW30CXC595	3000	1411	10600	562×10^3	0.900	0.388	160	0.033	0.040	W4
W1411LC360	SW36CXC595	3600	1411	10600	562×10^3	0.900	0.388	160	0.033	0.040	W4
W1520NC500	SW50CXC620	5000	1520	12000	720×10^3	1.150	0.450	150	0.022	0.026	W5
W1520NC600	SW60CXC620	6000	1520	12000	720×10^3	1.150	0.450	150	0.022	0.026	W5
W1524LC240	SW24CXC635	2400	1524	12700	810×10^3	0.870	0.323	160	0.033	0.040	W4
W1524LC300	SW30CXC635	3000	1524	12700	810×10^3	0.870	0.323	160	0.033	0.040	W4
W1608NC400	SW40CXC680	4000	1608	13000	850×10^3	0.975	0.501	160	0.022	0.026	W5
W1608NC500	SW50CXC680	5000	1608	13000	850×10^3	0.975	0.501	160	0.022	0.026	W5
W1748LC080	SW08CXC805	800	1748	15400	1.19×10^6	0.870	0.280	175	0.033	0.040	W4
W1748LC180	SW18CXC805	1800	1748	15400	1.19×10^6	0.870	0.280	175	0.033	0.040	W4
W1748LC220	SW22CXC805	2200	1748	15400	1.19×10^6	0.870	0.280	175	0.033	0.040	W4
W1856NC400	SW40CXC815	4000	1856	16000	1.28×10^6	0.975	0.348	160	0.022	0.026	W5
W1856NC500	SW50CXC815	5000	1856	16000	1.28×10^6	0.975	0.348	160	0.022	0.026	W5
W2020NC360	SW36CXC818	3600	2020	18000	1.62×10^6	1.000	0.320	160	0.020	0.022	W5
W2020NC450	SW45CXC818	4500	2020	18000	1.62×10^6	1.000	0.320	160	0.020	0.022	W5
W2052NC300	SW30CXC820	3000	2052	19500	1.90×10^6	0.865	0.288	160	0.022	0.026	W5
W2052NC400	SW40CXC820	4000	2052	19500	1.90×10^6	0.865	0.288	160	0.022	0.026	W5
W2054NC360	SW36CXC920	3600	2054	19000	1.81×10^6	0.800	0.300	160	0.022	0.026	W5
W2054NC450	SW45CXC920	4500	2054	19000	1.81×10^6	0.800	0.300	160	0.022	0.026	W5
W2058LC020	SW02CXC935	200	2058	19500	1.90×10^6	0.790	0.192	175	0.033	0.040	W4
W2058LC100	SW10CXC935	1000	2058	19500	1.90×10^6	0.790	0.192	175	0.033	0.040	W4
W2058LC120	SW12CXC935	1200	2058	19500	1.90×10^6	0.790	0.192	175	0.033	0.040	W4

Outline drawings on pages 188 - 224

Rectifier Diodes - Capsule Types, continued

Type ▶ New Part No.	Old Part No.	V _{RRM}	I _{FAV} T _k =55°C	I _{FSM} 10ms ½ sine V _R ≤ 60% V _{RRM}	I ² t V _R ≤ 60% V _{RRM} A ² s	V _{TO} @ T _j max	r _T	T _j max	R _{thJK}		Fig. No.
		V	A	A		V	mΩ	°C	180° Sine K/W	120° Rect. K/W	
W2134NC300	SW30CXC930	3000	2134	20000	2.00 x 10 ⁶	0.865	0.260	160	0.022	0.026	W5
W2134NC400	SW40CXC930	4000	2134	20000	2.00 x 10 ⁶	0.865	0.260	160	0.022	0.026	W5
W2416NC160	SW16CXC950	1600	2416	25500	3.25 x 10 ⁶	0.780	0.200	160	0.022	0.026	W5
W2416NC200	SW20CXC950	2000	2416	25500	3.25 x 10 ⁶	0.780	0.200	160	0.022	0.026	W5
W2416NC250	SW25CXC950	2500	2416	25500	3.25 x 10 ⁶	0.780	0.200	160	0.022	0.026	W5
W2624NC160	SW16CXC11C	1600	2624	28000	3.92 x 10 ⁶	0.780	0.160	160	0.022	0.026	W5
W2624NC200	SW20CXC11C	2000	2624	28000	3.92 x 10 ⁶	0.780	0.160	160	0.022	0.026	W5
W2624NC250	SW25CXC11C	2500	2624	28000	3.92 x 10 ⁶	0.780	0.160	160	0.022	0.026	W5
W2664NC300	SW30CXC1170	3000	2664	26500	3.51 x 10 ⁶	0.824	0.174	160	0.020	0.022	W5
W2664NC400	SW40CXC1170	4000	2664	26500	3.51 x 10 ⁶	0.824	0.174	160	0.020	0.022	W5
W2820VC360	SW36CXC1100	3600	2820	26200	3.43 x 10 ⁶	1.300	0.147	160	0.016	0.018	W6
W2820VC450	SW45CXC1100	4500	2820	26200	3.43 x 10 ⁶	1.300	0.147	160	0.016	0.018	W6
W2820VF360	SW36FXC1100	3600	2820	26200	3.43 x 10 ⁶	1.300	0.147	160	0.016	0.018	W43
W2820VF450	SW45FXC1100	4500	2820	26200	3.43 x 10 ⁶	1.300	0.147	160	0.016	0.018	W43
W2958NC280	SW28CXC12C	2800	2958	28000	3.92 x 10 ⁶	0.807	0.167	175	0.020	0.022	W5
W2958NC350	SW35CXC12C	3500	2958	28000	3.92 x 10 ⁶	0.807	0.167	175	0.020	0.022	W5
W3128VC300	SW30CXC13C	3000	3128	30000	4.50 x 10 ⁶	0.875	0.158	160	0.016	0.018	W6
W3128VC400	SW40CXC13C	4000	3128	30000	4.50 x 10 ⁶	0.875	0.158	160	0.016	0.018	W6
W3128VF300	SW30FXC13C	3000	3128	30000	4.50 x 10 ⁶	0.875	0.158	160	0.016	0.018	W43
W3128VF400	SW40FXC13C	4000	3128	30000	4.50 x 10 ⁶	0.875	0.158	160	0.016	0.018	W43
W3270NC080	SW08CXC14C	800	3270	33000	5.45 x 10 ⁶	0.826	0.104	175	0.022	0.026	W5
W3270NC160	SW16CXC14C	1600	3270	33000	5.45 x 10 ⁶	0.826	0.104	175	0.022	0.026	W5
W3270NC200	SW20CXC14C	2000	3270	33000	5.45 x 10 ⁶	0.826	0.104	175	0.022	0.026	W5
W3697VC160	SW16CXC16C	1600	3697	40000	8.00 x 10 ⁶	0.860	0.100	160	0.016	0.018	W6
W3697VC220	SW22CXC16C	2200	3697	40000	8.00 x 10 ⁶	0.860	0.100	160	0.016	0.018	W6
W3697VC280	SW28CXC16C	2800	3697	40000	8.00 x 10 ⁶	0.860	0.100	160	0.016	0.018	W6
W3697VF160	SW16FXC16C	1600	3697	40000	8.00 x 10 ⁶	0.860	0.100	160	0.016	0.018	W43
W3697VF220	SW22FXC16C	2200	3697	40000	8.00 x 10 ⁶	0.860	0.100	160	0.016	0.018	W43
W3697VF280	SW28FXC16C	2800	3697	40000	8.00 x 10 ⁶	0.860	0.100	160	0.016	0.018	W43
W3743ZC400	SW40CXC15C	4000	3743	35000	6.13 x 10 ⁶	0.976	0.170	160	0.011	0.012	W7
W3743ZC500	SW50CXC15C	5000	3743	35000	6.13 x 10 ⁶	0.976	0.170	160	0.011	0.012	W7
W3743ZD400	SW40DXC15C	4000	3743	35000	6.13 x 10 ⁶	0.976	0.170	160	0.011	0.012	W42
W3743ZD500	SW50DXC15C	5000	3743	35000	6.13 x 10 ⁶	0.976	0.170	160	0.011	0.012	W42
▶ W3841VC300	SW30CXC17C	3000	3841	39800	7.92 x 10 ⁶	0.860	0.115	175	0.016	0.018	W6
▶ W3841VC340	SW34CXC17C	3400	3841	39800	7.92 x 10 ⁶	0.860	0.115	175	0.016	0.018	W6
▶ W3841VF300	SW30FXC17C	3000	3841	39800	7.92 x 10 ⁶	0.860	0.115	175	0.016	0.018	W43
▶ W3841VF340	SW34FXC17C	3400	3841	39800	7.92 x 10 ⁶	0.860	0.115	175	0.016	0.018	W43
W4096ZC340	SW34CXC1870	3400	4096	41700	8.70 x 10 ⁶	0.730	0.158	160	0.011	0.012	W7
W4096ZC450	SW45CXC1870	4500	4096	41700	8.70 x 10 ⁶	0.730	0.158	160	0.011	0.012	W7
W4096ZD340	SW34DXC1870	3400	4096	41700	8.70 x 10 ⁶	0.730	0.158	160	0.011	0.012	W42
W4096ZD450	SW45DXC1870	4500	4096	41700	8.70 x 10 ⁶	0.730	0.158	160	0.011	0.012	W42
W4307ZC200	SW20CXC20C	2000	4307	55000	15.1 x 10 ⁶	0.800	0.133	160	0.011	0.012	W7
W4307ZC240	SW24CXC20C	2400	4307	55000	15.1 x 10 ⁶	0.800	0.133	160	0.011	0.012	W7
W4307ZC300	SW30CXC20C	3000	4307	55000	15.1 x 10 ⁶	0.800	0.133	160	0.011	0.012	W7
W4307ZD200	SW20DXC20C	2000	4307	55000	15.1 x 10 ⁶	0.800	0.133	160	0.011	0.012	W42
W4307ZD240	SW24DXC20C	2400	4307	55000	15.1 x 10 ⁶	0.800	0.133	160	0.011	0.012	W42
W4307ZD300	SW30DXC20C	3000	4307	55000	15.1 x 10 ⁶	0.800	0.133	160	0.011	0.012	W42
W4534NC020	SW02CXC19C	200	4543	40000	8.00 x 10 ⁶	0.765	0.052	190	0.022	0.026	W5
W4534NC060	SW06CXC19C	600	4543	40000	8.00 x 10 ⁶	0.765	0.052	190	0.022	0.026	W5
W5092ZC240	SW24CXC18C	2400	5092	58000	16.8 x 10 ⁶	0.874	0.079	160	0.011	0.012	W7
W5092ZC280	SW28CXC18C	2800	5092	58000	16.8 x 10 ⁶	0.874	0.079	160	0.011	0.012	W7
W5092ZC350	SW35CXC18C	3500	5092	58000	16.8 x 10 ⁶	0.874	0.079	160	0.011	0.012	W7
W5092ZD240	SW24DXC18C	2400	5092	58000	16.8 x 10 ⁶	0.874	0.079	160	0.011	0.012	W42
W5092ZD280	SW28DXC18C	2800	5092	58000	16.8 x 10 ⁶	0.874	0.079	160	0.011	0.012	W42
W5092ZD350	SW35DXC18C	3500	5092	58000	16.8 x 10 ⁶	0.874	0.079	160	0.011	0.012	W42

Rectifier Diodes - Capsule Types, continued

Type		V_{RRM}	I_{FAV} $T_K=55^\circ\text{C}$	I_{FSM} 10ms ½ sine $V_R \leq 60\% V_{RRM}$	I^2t $V_R \leq 60\%$ V_{RRM} A^2s	V_{TO} $@T_{jmax}$	r_T	T_{jmax}	R_{thJK}		Fig. No.
► New Part No.	Old Part No.	V	A	A		V	mΩ	°C	180° Sine K/W	120° Rect. K/W	
W5282ZC200	SW20CXC21C	2000	5282	60000	18.0×10^6	0.970	0.064	160	0.011	0.012	W7
W5282ZC240	SW24CXC21C	2400	5282	60000	18.0×10^6	0.970	0.064	160	0.011	0.012	W7
W5282ZC300	SW30CXC21C	3000	5282	60000	18.0×10^6	0.970	0.064	160	0.011	0.012	W7
W5282ZD200	SW20DXC21C	2000	5282	60000	18.0×10^6	0.970	0.064	160	0.011	0.012	W42
W5282ZD240	SW24DXC21C	2400	5282	60000	18.0×10^6	0.970	0.064	160	0.011	0.012	W42
W5282ZD300	SW30DXC21C	3000	5282	60000	18.0×10^6	0.970	0.064	160	0.011	0.012	W42
► W5292TC500	N/A	5000	5292	52700	13.9×10^6	1.027	0.111	160	0.008	0.0085	W14
► W5292TC560	N/A	5600	5292	52700	13.9×10^6	1.027	0.111	160	0.008	0.0085	W14
► W5292TD500	N/A	5000	5292	52700	13.9×10^6	1.027	0.111	160	0.008	0.0085	W19
► W5292TD560	N/A	5600	5292	52700	13.9×10^6	1.027	0.111	160	0.008	0.0085	W19
W5439VC020	SW02CXC22C	200	5439	52000	13.5×10^6	0.650	0.067	190	0.016	0.018	W6
W5439VC100	SW10CXC22C	1000	5439	52000	13.5×10^6	0.650	0.067	190	0.016	0.018	W6
W5439VC140	SW14CXC22C	1400	5439	52000	13.5×10^6	0.650	0.067	190	0.016	0.018	W6
W5439VF020	SW02FXC22C	200	5439	52000	13.5×10^6	0.650	0.067	190	0.016	0.018	W43
W5439VF100	SW10FXC22C	1000	5439	52000	13.5×10^6	0.650	0.067	190	0.016	0.018	W43
W5439VF140	SW14FXC22C	1400	5439	52000	13.5×10^6	0.650	0.067	190	0.016	0.018	W43
W5696VC020	SW02CXC27C	200	5696	53000	14.0×10^6	0.650	0.059	190	0.016	0.018	W6
W5696VC100	SW10CXC27C	1000	5696	53000	14.0×10^6	0.650	0.059	190	0.016	0.018	W6
W5696VC140	SW14CXC27C	1400	5696	53000	14.0×10^6	0.650	0.059	190	0.016	0.018	W6
W5696VF020	SW02FXC27C	200	5696	53000	14.0×10^6	0.650	0.059	190	0.016	0.018	W43
W5696VF100	SW10FXC27C	1000	5696	53000	14.0×10^6	0.650	0.059	190	0.016	0.018	W43
W5696VF140	SW14FXC27C	1400	5696	53000	14.0×10^6	0.650	0.059	190	0.016	0.018	W43
W5838ZC120	SW12CXC26C	1200	5838	64000	20.5×10^6	0.800	0.074	175	0.011	0.012	W7
W5838ZC180	SW18CXC26C	1800	5838	64000	20.5×10^6	0.800	0.074	175	0.011	0.012	W7
W5838ZC220	SW22CXC26C	2200	5838	64000	20.5×10^6	0.800	0.074	175	0.011	0.012	W7
W5838ZD120	SW12DXC26C	1200	5838	64000	20.5×10^6	0.800	0.074	175	0.011	0.012	W42
W5838ZD180	SW18DXC26C	1800	5838	64000	20.5×10^6	0.800	0.074	175	0.011	0.012	W42
W5838ZD220	SW22DXC26C	2200	5838	64000	20.5×10^6	0.800	0.074	175	0.011	0.012	W42
W6262ZC120	SW12CXC2850	1200	6262	67000	22.4×10^6	0.740	0.065	175	0.011	0.012	W7
W6262ZC200	SW20CXC2850	2000	6262	67000	22.4×10^6	0.740	0.065	175	0.011	0.012	W7
W6262ZC240	SW24CXC2850	2400	6262	67000	22.4×10^6	0.740	0.065	175	0.011	0.012	W7
W6262ZD120	SW12DXC2850	1200	6262	67000	22.4×10^6	0.740	0.065	175	0.011	0.012	W42
W6262ZD200	SW20DXC2850	2000	6262	67000	22.4×10^6	0.740	0.065	175	0.011	0.012	W42
W6262ZD240	SW24DXC2850	2400	6262	67000	22.4×10^6	0.740	0.065	175	0.011	0.012	W42
W7675ZC020	SW02CXC30C	200	7675	68000	23.1×10^6	0.650	0.050	190	0.011	0.012	W7
W7675ZC100	SW10CXC30C	1000	7675	68000	23.1×10^6	0.650	0.050	190	0.011	0.012	W7
W7675ZC140	SW14CXC30C	1400	7675	68000	23.1×10^6	0.650	0.050	190	0.011	0.012	W7
W7675ZD020	SW02DXC30C	200	7675	68000	23.1×10^6	0.650	0.050	190	0.011	0.012	W42
W7675ZD100	SW10DXC30C	1000	7675	68000	23.1×10^6	0.650	0.050	190	0.011	0.012	W42
W7675ZD140	SW14DXC30C	1400	7675	68000	23.1×10^6	0.650	0.050	190	0.011	0.012	W42
W8405ZC020	SW02CXC32C	200	8405	72000	25.9×10^6	0.670	0.038	190	0.011	0.012	W7
W8405ZC100	SW10CXC32C	1000	8405	72000	25.9×10^6	0.670	0.038	190	0.011	0.012	W7
W8405ZC140	SW14CXC32C	1400	8405	72000	25.9×10^6	0.670	0.038	190	0.011	0.012	W7
W8405ZD020	SW02DXC32C	200	8405	72000	25.9×10^6	0.670	0.038	190	0.011	0.012	W42
W8405ZD100	SW10DXC32C	1000	8405	72000	25.9×10^6	0.670	0.038	190	0.011	0.012	W42
W8405ZD140	SW14DXC32C	1400	8405	72000	25.9×10^6	0.670	0.038	190	0.011	0.012	W42

Rectifier Diodes - Capsule Types, continued



Fig. W1
Weight 70g



Fig. W2
Weight 90 g



Fig. W3
Weight 140 g



Fig. W4
Weight 340 g



Fig. W5
Weight 510 g



Fig. W6
Weight 1000 g



Fig. W7
Weight 1700 g



Fig. W28
Weight 1230 g



Fig. W29
Weight 1700 g



Fig. W42
Weight 1200 g



Fig. W43
Weight 800 g

Fast Recovery Diodes are an essential complement to any switching device and are more often than not the limiting factor in the design and performance of modern power converters. To address the needs of our customers, we have developed an unparalleled range of Fast Recovery Diodes.

These diodes are available with blocking voltages up to 6kV making them suitable for operation with DC link voltages up to 3.3kV and average current ratings to 4kA depending upon type. The devices utilise compression bonding along with both

alloyed and floating silicon technologies to deliver robust devices that you can rely on in demanding applications.

This range has been re-classified as follows to aid appropriate device selection; **Fast Recovery, Soft Recovery, Extra Fast Recovery Diodes and HP Sonic-FRDs™**.

Fast Recovery Diodes: These parts are particularly suitable for use as antiparallel diodes in Gate Turn-Off thyristors and Fast Thyristor inverters, and as series and freewheel diodes for choppers.

Fast Recovery Diodes - Stud Types

Type	V _{RRM}	I _{FAV} T _K = 55°C	I _{FSM} 10ms ½ sine V _R ≤ 60% V _{RRM}	I ² t V _{RRM} A ² s	Typ. Reverse Recovery Parameters				V _{T0} @ T _{j max}	r _T mΩ	T _{j max} °C	R _{thJC} d.c. 180° sine K/W	Fig. No.	
					T _{j max} (50% Chord)									
► New Part No.	Old Part No.	V	A	A	A ² s	t _{rr} µs	Q _r µC	@ I _{FM} A	@ -di _r /dt A/µs	V	mΩ	°C	K/W	Fig. No.
M0130SL200	SM20MCN094	2000	130	2240	25 × 10 ³	2.60	240	1000	150	1.290	1.540	125	0.300	W20
M0130SL250	SM25MCN094	2500	130	2240	25 × 10 ³	2.60	240	1000	150	1.290	1.540	125	0.300	W20
M0130RL200	SM20MCR094	2000	130	2240	25 × 10 ³	2.60	240	1000	150	1.290	1.540	125	0.300	W20
M0130RL250	SM25MCR094	2500	130	2240	25 × 10 ³	2.60	240	1000	150	1.290	1.540	125	0.300	W20
► M0130SM200	N/A	2000	130	2240	25 × 10 ³	2.60	240	1000	150	1.290	1.540	125	0.300	W21
► M0130SM250	N/A	2500	130	2240	25 × 10 ³	2.60	240	1000	150	1.290	1.540	125	0.300	W21
► M0130RM200	N/A	2000	130	2240	25 × 10 ³	2.60	240	1000	150	1.290	1.540	125	0.300	W21
► M0130RM250	N/A	2500	130	2240	25 × 10 ³	2.60	240	1000	150	1.290	1.540	125	0.300	W21
► M0139SL120	N/A	1200	139	2450	30 × 10 ³	1.00	70	1000	100	1.240	1.280	125	0.300	W20
► M0139SL180	N/A	1800	139	2450	30 × 10 ³	1.00	70	1000	100	1.240	1.280	125	0.300	W20
► M0139RL120	N/A	1200	139	2450	30 × 10 ³	1.00	70	1000	100	1.240	1.280	125	0.300	W20
► M0139RL180	N/A	1800	139	2450	30 × 10 ³	1.00	70	1000	100	1.240	1.280	125	0.300	W20
M0139SM120	SM12PHN100	1200	139	2450	30 × 10 ³	1.00	70	1000	100	1.240	1.280	125	0.300	W21
M0139SM180	SM18PHN100	1800	139	2450	30 × 10 ³	1.00	70	1000	100	1.240	1.280	125	0.300	W21
M0139RM120	SM12PHR100	1200	139	2450	30 × 10 ³	1.00	70	1000	100	1.240	1.280	125	0.300	W21
M0139RM180	SM18PHR100	1800	139	2450	30 × 10 ³	1.00	70	1000	100	1.240	1.280	125	0.300	W21
M0268SC200	SM20PHN134	2000	268	4250	90.3 × 10 ³	2.80	230	1000	150	1.210	1.200	125	0.130	W24
M0268SC250	SM25PHN134	2500	268	4250	90.3 × 10 ³	2.80	230	1000	150	1.210	1.200	125	0.130	W24
M0268RC200	SM20PHR134	2000	268	4250	90.3 × 10 ³	2.80	230	1000	150	1.210	1.200	125	0.130	W24
M0268RC250	SM25PHR134	2500	268	4250	90.3 × 10 ³	2.80	230	1000	150	1.210	1.200	125	0.130	W24
M0268SJ200	SM20PCN134	2000	268	4250	90.3 × 10 ³	2.80	230	1000	150	1.210	1.200	125	0.130	W22
M0268SJ250	SM25PCN134	2500	268	4250	90.3 × 10 ³	2.80	230	1000	150	1.210	1.200	125	0.130	W22
M0268RJ200	SM20PCR134	2000	268	4250	90.3 × 10 ³	2.80	230	1000	150	1.210	1.200	125	0.130	W22
M0268RJ250	SM25PCR134	2500	268	4250	90.3 × 10 ³	2.80	230	1000	150	1.210	1.200	125	0.130	W22
M0280SC200	SM20PHN144	2000	280	4500	100 × 10 ³	2.80	342	1000	150	1.280	0.920	125	0.130	W24
M0280SC250	SM25PHN144	2500	280	4500	100 × 10 ³	2.80	342	1000	150	1.280	0.920	125	0.130	W24
M0280RC200	SM20PHR144	2000	280	4500	100 × 10 ³	2.80	342	1000	150	1.280	0.920	125	0.130	W24
M0280RC250	SM25PHR144	2500	280	4500	100 × 10 ³	2.80	342	1000	150	1.280	0.920	125	0.130	W24
M0280SJ200	SM20PCN144	2000	280	4500	100 × 10 ³	2.80	342	1000	150	1.280	0.920	125	0.130	W22
M0280SJ250	SM25PCN144	2500	280	4500	100 × 10 ³	2.80	342	1000	150	1.280	0.920	125	0.130	W22
M0280RJ200	SM20PCR144	2000	280	4500	100 × 10 ³	2.80	342	1000	150	1.280	0.920	125	0.130	W22
M0280RJ250	SM25PCR144	2500	280	4500	100 × 10 ³	2.80	342	1000	150	1.280	0.920	125	0.130	W22
M0334SC120	SM12PHN174	1200	334	4500	101 × 10 ³	3.50	160	550	40	1.000	0.740	125	0.130	W24
M0334SC200	SM20PHN174	2000	334	4500	101 × 10 ³	3.50	160	550	40	1.000	0.740	125	0.130	W24
M0334RC120	SM12PHR174	1200	334	4500	101 × 10 ³	3.50	160	550	40	1.000	0.740	125	0.130	W24
M0334RC200	SM20PHR174	2000	334	4500	101 × 10 ³	3.50	160	550	40	1.000	0.740	125	0.130	W24
M0334SJ120	N/A	1200	334	4500	101 × 10 ³	3.50	160	550	40	1.000	0.740	125	0.130	W22
M0334SJ200	N/A	2000	334	4500	101 × 10 ³	3.50	160	550	40	1.000	0.740	125	0.130	W22
M0334RJ120	N/A	1200	334	4500	101 × 10 ³	3.50	160	550	40	1.000	0.740	125	0.130	W22
M0334RJ200	N/A	2000	334	4500	101 × 10 ³	3.50	160	550	40	1.000	0.740	125	0.130	W22
M0336SA120	SM12PHN170	1200	336	4500	101 × 10 ³	3.00	75	550	40	1.020	0.700	125	0.130	W23
M0336SA140	SM14PHN170	1400	336	4500	101 × 10 ³	3.00	75	550	40	1.020	0.700	125	0.130	W23
M0336RA120	SM12PHR170	1200	336	4500	101 × 10 ³	3.00	75	550	40	1.020	0.700	125	0.130	W23
M0336RA140	SM14PHR170	1400	336	4500	101 × 10 ³	3.00	75	550	40	1.020	0.700	125	0.130	W23

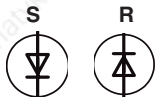

Fig. W20 - 85 g



Fig. W21 - min. 85 g



Fig. W22 - 200 g



Fig. W23 - 250 g



Fig. W24 - 250 g

Fast Recovery Diodes - Capsule Types

Type		V _{RRM} V	I _{FAV} T _K =55°C A	I _{FSM} 10ms ½ sine V _R ≤ 60% V _{RRM} A	I ² t V _R ≤ 60% V _{RRM} A ² s	Typ. Reverse Recovery Parameters T _{JM} (50% Chord)				V _{To} @ T _J max V	r _T mΩ	T _J max °C	R _{thJK} d.c. 180° sine K/W	Fig. No.
Part No.	Old Part No.					t _{rr} μs	Q _r μC	@ I _{FM} A	@ -di _r /dt A/μs					
M0588LC400	SM40CXC344	4000	588	3955	78.2 × 10 ³	3.5	200	1000	60	2.32	1.77	150	0.033	W4
M0588LC450	SM45CXC344	4500	588	3955	78.2 × 10 ³	3.5	200	1000	60	2.32	1.77	150	0.033	W4
M0790YC200	N/A	2000	790	9000	405 × 10 ³	4.0	300	1000	60	1.27	0.58	150	0.050	W2
M0790YC250	N/A	2500	790	9000	405 × 10 ³	4.0	300	1000	60	1.27	0.58	150	0.050	W2
M0790YH200	N/A	2000	790	9000	405 × 10 ³	4.0	300	1000	60	1.27	0.58	150	0.050	W3
M0790YH250	N/A	2500	790	9000	405 × 10 ³	4.0	300	1000	60	1.27	0.58	150	0.050	W3
M0914LC200	SM20CXC804	2000	914	8500	361 × 10 ³	3.2	170	1000	60	1.768	0.653	150	0.032	W4
M0914LC250	SM25CXC804	2500	914	8500	361 × 10 ³	3.2	170	1000	60	1.768	0.653	150	0.032	W4
M1010NC400	SM40CXC604	4000	1010	9600	461 × 10 ³	3.2	700	1000	200	1.70	1.03	150	0.022	W5
M1010NC450	SM45CXC604	4500	1010	9600	461 × 10 ³	3.2	700	1000	200	1.70	1.03	150	0.022	W5
M1163NC400	SM40CXC614	4000	1163	10800	583 × 10 ³	6.4	700	1000	60	1.50	0.77	150	0.022	W5
M1163NC450	SM45CXC614	4500	1163	10800	583 × 10 ³	6.4	700	1000	60	1.50	0.77	150	0.022	W5
M1502NC200	SM20CXC334	2000	1502	17000	1.45 × 10 ⁶	2.3	420	1000	60	1.24	0.44	150	0.022	W5
M1502NC250	SM25CXC334	2500	1502	17000	1.45 × 10 ⁶	2.3	420	1000	60	1.24	0.44	150	0.022	W5
M1583VC400	SM40CXC864	4000	1583	24800	3.08 × 10 ⁶	5.0	1100	1000	200	1.69	0.53	150	0.016	W6
M1583VC450	SM45CXC864	4500	1583	24800	3.08 × 10 ⁶	5.0	1100	1000	200	1.69	0.53	150	0.016	W6
M1583VF400	SM40FXC864	4000	1583	24800	3.08 × 10 ⁶	5.0	1100	1000	200	1.69	0.53	150	0.016	W43
M1583VF450	SM45FXC864	4500	1583	24800	3.08 × 10 ⁶	5.0	1100	1000	200	1.69	0.53	150	0.016	W43
M1609NC200	SM20CXC915	2000	1609	17500	1.53 × 10 ⁶	3.2	600	1000	200	1.31	0.35	150	0.022	W5
M1609NC260	SM26CXC915	2600	1609	17500	1.53 × 10 ⁶	3.2	600	1000	200	1.31	0.35	150	0.022	W5
M2408NC020	SM02CXC504	200	2408	24000	2.88 × 10 ⁶	1.9	160	1000	200	1.07	0.12	150	0.022	W5
M2408NC060	SM06CXC504	600	2408	24000	2.88 × 10 ⁶	1.9	160	1000	200	1.07	0.12	150	0.022	W5
M2408ND020	SM02CXC504	200	2408	24000	2.88 × 10 ⁶	1.9	160	1000	200	1.07	0.12	150	0.022	W5
M2408ND060	SM06CXC504	600	2408	24000	2.88 × 10 ⁶	1.9	160	1000	200	1.07	0.12	150	0.022	W5
M2639ZC360	SM36CXC954	3600	2639	27520	3.79 × 10 ⁶	8.5	1200	1000	60	1.38	0.29	150	0.011	W7
M2639ZC420	SM42CXC954	4200	2639	27520	3.79 × 10 ⁶	8.5	1200	1000	60	1.38	0.29	150	0.011	W7
M2639ZD360	SM36DXC954	3600	2639	27520	3.79 × 10 ⁶	8.5	1200	1000	60	1.38	0.29	150	0.011	W42
M2639ZD420	SM42DXC954	4200	2639	27520	3.79 × 10 ⁶	8.5	1200	1000	60	1.38	0.29	150	0.011	W42
M2698ZC250	SM25CXC964	2500	2698	27800	3.86 × 10 ⁶	6.2	620	1000	60	1.00	0.33	150	0.011	W7
M2698ZC280	SM28CXC964	2800	2698	27800	3.86 × 10 ⁶	6.2	620	1000	60	1.00	0.33	150	0.011	W7
M2698ZC350	SM35CXC964	3500	2698	27800	3.86 × 10 ⁶	6.2	620	1000	60	1.00	0.33	150	0.011	W7
M2698ZD250	SM25DXC964	2500	2698	27800	3.86 × 10 ⁶	6.2	620	1000	60	1.00	0.33	150	0.011	W42
M2698ZD280	SM28DXC964	2800	2698	27800	3.86 × 10 ⁶	6.2	620	1000	60	1.00	0.33	150	0.011	W42
M2698ZD350	SM35DXC964	3500	2698	27800	3.86 × 10 ⁶	6.2	620	1000	60	1.00	0.33	150	0.011	W42
M2837VC180	SM18CXC968	1800	2837	31800	5.1 × 10 ⁶	7.0	1100	1000	60	0.90	0.17	150	0.016	W6
M2837VC250	SM25CXC968	2500	2837	31800	5.1 × 10 ⁶	7.0	1100	1000	60	0.90	0.17	150	0.016	W6
M2837VF180	SM18FXC968	1800	2837	31800	5.1 × 10 ⁶	7.0	1100	1000	60	0.90	0.17	150	0.016	W43
M2837VF250	SM25FXC968	2500	2837	31800	5.1 × 10 ⁶	7.0	1100	1000	60	0.90	0.17	150	0.016	W43
M3770ZC200	SM20CXC974	2000	3770	44000	9.68 × 10 ⁶	7.0	1500	1000	60	1.19	1.18	150	0.011	W7
M3770ZC240	SM24CXC974	2400	3770	44000	9.68 × 10 ⁶	7.0	1500	1000	60	1.19	1.18	150	0.011	W7
M3770ZC300	SM30CXC974	3000	3770	44000	9.68 × 10 ⁶	7.0	1500	1000	60	1.19	1.18	150	0.011	W7
M3770ZD200	SM20DXC974	2000	3770	44000	9.68 × 10 ⁶	7.0	1500	1000	60	1.19	1.18	150	0.011	W42
M3770ZD240	SM24DXC974	2400	3770	44000	9.68 × 10 ⁶	7.0	1500	1000	60	1.19	1.18	150	0.011	W42
M3770ZD300	SM30DXC974	3000	3770	44000	9.68 × 10 ⁶	7.0	1500	1000	60	1.190	1.18	150	0.011	W42



Fig. W2 - 80 g



Fig. W3 - 140 g



Fig. W4 - 340 g



Fig. W5 - 510 g



Fig. W6 - 1000 g



Fig. W7 - 1700 g



Fig. W42 - 1200 g



Fig. W43 - 800 g

Soft Recovery Diodes - Capsule Types

These parts are particularly suitable where soft recovery is required, such as RCD snubber, voltage clamping and snubberless applications.

Type		V _{RRM} V	I _{FAV} T _K = 55°C A	I _{FSM} 10ms ½ sine V _R ≤ 60% V _{RRM} A	I ² t V _R ≤ 60% V _{RRM} A ² s	Typ. Reverse Recovery Parameters				V _{TO} @T _{max} V	r _T mΩ	T _J max °C	R _{thJK} d.c. 180° sine K/W	Fig. No.
Part No.	Old Part No.					t _{rr} µs	Q _r µC	@I _{FM} A	@-di _r /dt A/µs					
M0225YH300	SM30HXC084	3000	225	2000	20 × 10 ³	3.00	100	550	40	1.900	4.160	150	0.100	W3
M0225YH360	SM36HXC084	3600	225	2000	20 × 10 ³	3.00	100	550	40	1.900	4.160	150	0.100	W3
M0225YH450	SM45HXC084	4500	225	2000	20 × 10 ³	3.00	100	550	40	1.900	4.160	150	0.100	W3
M0310YH300	SM30HXC103	3000	310	4590	105 × 10 ³	2.80	210	1000	100	1.490	2.060	150	0.100	W3
M0310YH350	SM35HXC103	3500	310	4590	105 × 10 ³	2.80	210	1000	100	1.490	2.060	150	0.100	W3
M0347WC160	SM16CXC134	1600	347	4250	90.3 × 10 ³	2.80	60	550	40	1.210	1.200	125	0.090	W1
M0347WC200	SM20CXC134	2000	347	4250	90.3 × 10 ³	2.80	60	550	40	1.210	1.200	125	0.090	W1
M0347WC250	SM25CXC134	2500	347	4250	90.3 × 10 ³	2.80	60	550	40	1.210	1.200	125	0.090	W1
M0358WC120	SM12CXC100	1200	358	2450	30 × 10 ³	1.40	65	1000	100	1.460	0.800	125	0.090	W1
M0358WC180	SM18CXC100	1800	358	2450	30 × 10 ³	1.40	65	1000	100	1.460	0.800	125	0.090	W1
M0367WC140	SM14CXC144	1400	367	4500	101 × 10 ³	3.30	120	550	40	1.280	0.920	125	0.090	W1
M0367WC220	SM22CXC144	2200	367	4500	101 × 10 ³	3.30	120	550	40	1.280	0.920	125	0.090	W1
M0367WC280	SM28CXC144	2800	367	4500	101 × 10 ³	3.30	120	550	40	1.280	0.920	125	0.090	W1
M0371YH350	SM35HXC164	3500	371	4900	120 × 10 ³	3.20	625	1000	200	1.050	1.650	150	0.100	W3
M0371YH450	SM45HXC164	4500	371	4900	120 × 10 ³	3.20	625	1000	200	1.050	1.650	150	0.100	W3
M0433WC120	SM12CXC174	1200	433	4500	101 × 10 ³	3.50	120	550	40	1.000	0.740	125	0.090	W1
M0433WC160	SM16CXC174	1600	433	4500	101 × 10 ³	3.50	120	550	40	1.000	0.740	125	0.090	W1
M0433WC200	SM20CXC174	2000	433	4500	101 × 10 ³	3.50	120	550	40	1.000	0.740	125	0.090	W1
M0437WC080	SM08CXC170	800	437	4500	101 × 10 ³	3.00	75	550	40	1.020	0.700	125	0.090	W1
M0437WC140	SM14CXC170	1400	437	4500	101 × 10 ³	3.00	75	550	40	1.020	0.700	125	0.090	W1
M0451YC120	SM12CXC176	1200	451	4500	101 × 10 ³	2.80	120	550	40	1.000	0.740	125	0.085	W2
M0451YC160	SM16CXC176	1600	451	4500	101 × 10 ³	2.80	120	550	40	1.000	0.740	125	0.085	W2
M0451YC200	SM20CXC176	2000	451	4500	101 × 10 ³	2.80	120	550	40	1.000	0.740	125	0.085	W2
M0451YH120	N/A	1200	451	4500	101 × 10 ³	2.80	120	550	40	1.000	0.740	125	0.085	W3
M0451YH160	N/A	1600	451	4500	101 × 10 ³	2.80	120	550	40	1.000	0.740	125	0.085	W3
M0451YH200	N/A	2000	451	4500	101 × 10 ³	2.80	120	550	40	1.000	0.740	125	0.085	W3
M0659LC400	SM40CXC364	4000	659	7620	290 × 10 ³	4.20	270	1000	60	1.710	0.925	125	0.033	W4
M0659LC450	SM45CXC364	4500	659	7620	290 × 10 ³	4.20	270	1000	60	1.710	0.925	125	0.033	W4
M0710LC560	SM56CXC274	5600	710	8400	353 × 10 ³	4.00	1000	1000	200	1.450	0.875	125	0.033	W4
M0710LC600	SM60CXC274	6000	710	8400	353 × 10 ³	4.00	1000	1000	200	1.450	0.875	125	0.033	W4
M0736LC400	SM40CXC374	4000	736	9000	405 × 10 ³	5.20	450	1000	60	1.606	0.700	125	0.033	W4
M0736LC450	SM45CXC374	4500	736	9000	405 × 10 ³	5.20	450	1000	60	1.606	0.700	125	0.033	W4
M0759YC040	SM04CXC190	400	759	9500	450 × 10 ³	2.00	50	550	40	1.130	0.380	125	0.050	W2
M0759YC120	SM12CXC190	1200	759	9500	450 × 10 ³	2.00	50	550	40	1.130	0.380	125	0.050	W2
M0759YC160	SM16CXC190	1600	759	9500	450 × 10 ³	2.00	50	550	40	1.130	0.380	125	0.050	W2
M0759YH040	N/A	400	759	9500	450 × 10 ³	2.00	50	550	40	1.130	0.380	125	0.050	W3
M0759YH120	N/A	1200	759	9500	450 × 10 ³	2.00	50	550	40	1.130	0.380	125	0.050	W3
M0759YH160	N/A	1600	759	9500	450 × 10 ³	2.00	50	550	40	1.130	0.380	125	0.050	W3
M0859LC140	SM14CXC220	1400	859	10000	500 × 10 ³	3.00	110	800	50	1.170	0.320	125	0.044	W4
M0859LC160	SM16CXC220	1600	859	10000	500 × 10 ³	3.00	110	800	50	1.170	0.320	125	0.044	W4
M0863LC260	SM26CXC474	2600	863	10000	500 × 10 ³	4.80	370	1000	60	1.308	0.538	125	0.033	W4
M0863LC300	SM30CXC474	3000	863	10000	500 × 10 ³	4.80	370	1000	60	1.308	0.538	125	0.033	W4
M0863LC360	SM36CXC474	3600	863	10000	500 × 10 ³	4.80	370	1000	60	1.308	0.538	125	0.033	W4
M0872LC140	SM14CXC224	1400	872	10000	500 × 10 ³	4.00	280	1000	60	1.090	0.340	125	0.044	W4
M0872LC180	SM18CXC224	1800	872	10000	500 × 10 ³	4.00	280	1000	60	1.090	0.340	125	0.044	W4
M0872LC210	SM21CXC224	2100	872	10000	500 × 10 ³	4.00	280	1000	60	1.090	0.340	125	0.044	W4
M0955LC200	SM20CXC524	2000	955	11700	684 × 10 ³	3.00	240	1000	60	1.440	0.330	125	0.033	W4
M0955LC250	SM25CXC524	2500	955	11700	684 × 10 ³	3.00	240	1000	60	1.440	0.330	125	0.033	W4
M1022LC120	SM12CXC724	1200	1022	14000	980 × 10 ³	3.00	140	1000	60	1.240	0.330	125	0.033	W4
M1022LC160	SM16CXC724	1600	1022	14000	980 × 10 ³	3.00	140	1000	60	1.240	0.330	125	0.033	W4
M1022LC200	SM20CXC724	2000	1022	14000	980 × 10 ³	3.00	140	1000	60	1.240	0.330	125	0.033	W4
M1080LC100	SM10CXC314	1000	1080	13500	910 × 10 ³	1.90	50	1000	60	1.125	0.314	125	0.033	W4
M1080LC120	SM12CXC314	1200	1080	13500	910 × 10 ³	1.90	50	1000	60	1.125	0.314	125	0.033	W4
M1102NC500	SM50CXC574	5000	1102	13000	845 × 10 ³	5.50	1500	1000	200	1.360	0.557	125	0.022	W5
M1102NC600	SM60CXC574	6000	1102	13000	845 × 10 ³	5.50	1500	1000	200	1.360	0.557	125	0.022	W5
M1104NC400	SM40CXC624	4000	1104	13000	845 × 10 ³	6.00	800	1000	200	1.370	0.553	125	0.022	W5
M1104NC450	SM45CXC624	4500	1104	13000	845 × 10 ³	6.00	800	1000	200	1.370	0.553	125	0.022	W5

Soft Recovery Diodes - Capsule Types, continued

Type		V_{RRM}	I_{FAV} $T_K=55^\circ C$	I_{FSM} 10ms 1/2 sine $V_R \leq 60\% V_{RRM}$	I^2t $V_R \leq 60\%$ V_{RRM} A^2s	Typ. Reverse Recovery Parameters				V_{T0} $@T_{jmax}$	r_T	T_{jmax}	R_{thJK} d.c. 180° sine	Fig. No.
Part No.	Old Part No.	V	A	A		t_{rr} μs	Q_r μC	$@I_{FM}$ A	$@-di_p/dt$ A/ μs	V	m Ω	°C	K/W	
M1242NC260	SM26CXC824	2600	1242	16400	1.34×10^6	7.00	750	1000	60	1.270	0.420	125	0.022	W5
M1242NC360	SM36CXC824	3600	1242	16400	1.34×10^6	7.00	750	1000	60	1.270	0.420	125	0.022	W5
M1494NC160	SM16CXC924	1600	1494	19600	1.92×10^6	4.00	350	1000	60	1.150	0.265	125	0.022	W5
M1494NC250	SM25CXC924	2500	1494	19600	1.92×10^6	4.00	350	1000	60	1.150	0.265	125	0.022	W5
M1565VC400	SM40CXC394	4000	1565	19700	1.94×10^6	5.00	1550	1000	200	1.090	0.360	125	0.018	W6
M1565VC450	SM45CXC394	4500	1565	19700	1.94×10^6	5.00	1550	1000	200	1.090	0.360	125	0.018	W6
M1565VF400	SM40FXC394	4000	1565	19700	1.94×10^6	5.00	1550	1000	200	1.090	0.360	125	0.018	W43
M1565VF450	SM45FXC394	4500	1565	19700	1.94×10^6	5.00	1550	1000	200	1.090	0.360	125	0.018	W43
M1858NC120	SM12CXC514	1200	1858	25000	3.25×10^6	2.50	50	1000	60	1.130	0.127	125	0.022	W5
M1858NC160	SM16CXC514	1600	1858	25000	3.25×10^6	2.50	50	1000	60	1.130	0.127	125	0.022	W5
M2273VC300	N/A	3000	2273	28000	3.92×10^6	8.50	1300	1000	60	1.239	0.244	150	0.016	W6
M2273VC360	N/A	3600	2273	28000	3.92×10^6	8.50	1300	1000	60	1.239	0.244	150	0.016	W6
M2273VF300	N/A	3000	2273	28000	3.92×10^6	8.50	1300	1000	60	1.239	0.244	150	0.016	W43
M2273VF360	N/A	3600	2273	28000	3.92×10^6	8.50	1300	1000	60	1.239	0.244	150	0.016	W43
M2322ZC300	SM30CXC384	3000	2322	23000	2.64×10^6	6.50	1450	1000	150	1.670	0.186	125	0.011	W7
M2322ZC400	SM40CXC384	4000	2322	23000	2.64×10^6	6.50	1450	1000	150	1.670	0.186	125	0.011	W7
M2322ZD300	SM30DXC384	3000	2322	23000	2.64×10^6	6.50	1450	1000	150	1.670	0.186	125	0.011	W42
M2322ZD400	SM40DXC384	4000	2322	23000	2.64×10^6	6.50	1450	1000	150	1.670	0.186	125	0.011	W42
M2413VC200	N/A	2000	2413	32000	5.12×10^6	5.00	1275	1000	200	1.090	0.120	125	0.016	W6
M2413VC250	N/A	2000	2413	32000	5.12×10^6	5.00	1275	1000	200	1.090	0.120	125	0.016	W6
M2413VF200	N/A	2000	2413	32000	5.12×10^6	5.00	1275	1000	200	1.090	0.120	125	0.016	W43
M2413VF250	N/A	2000	2413	32000	5.12×10^6	5.00	1275	1000	200	1.090	0.120	125	0.016	W43



Fig. W1 - 70 g



Fig. W2 - 80 g



Fig. W3 - 140 g



Fig. W4 - 340 g



Fig. W5 - 510 g



Fig. W6 - 1000 g



Fig. W7 - 1700 g



Fig. W42 - 1200 g



Fig. W43 - 800 g

Extra Fast Recovery Diodes - Capsule Types

These products are designed to offer the lowest practical values of recovered charge whilst offering wide safe operating area and high di/dt capability required by modern switching components.

Type		V_{RRM}	I_{FAV} $T_K=55^\circ C$	I_{FSM} 10ms 1/2 sine	I^2t $V_R \leq 60\%$	Typ. Reverse Recovery Parameters					V_{T0} @ T_{jmax}	r_T	T_{jmax}	R_{thJK} d.c.	Fig. No.
► New Part No.	Old Part No.	V	A	$V_R \leq 60\% V_{RRM}$ A	V_{RRM} A^2s	I_{RM} A	T_{jmax} (50% Chord) t_{rr} μs	Q_r μC	@ I_{FM} A	@ -di/dt A/ μs	V	m Ω	$^\circ C$	180° sine K/W	
► F0240YC250	N/A	250	240	3100	48.1×10^3	40	2.0	40	550	40	2.271	2.853	150	0.100	W3
► F0240YH250	N/A	250	240	3100	48.1×10^3	40	2.0	40	550	40	2.271	2.853	150	0.100	W2
► F0240YC300	N/A	300	240	3100	48.1×10^3	40	2.0	40	550	40	2.271	2.853	150	0.100	W3
► F0240YH300	N/A	300	240	3100	48.1×10^3	40	2.0	40	550	40	2.271	2.853	150	0.100	W2
F0300WC140	F0258WC140	1400	240	2700	36.5×10^3	530	0.3	75	300	2000	1.760	2.210	125	0.095	W1
F0300WC180	F0258WC180	1800	240	2700	36.5×10^3	530	0.3	75	300	2000	1.760	2.210	125	0.095	W1
F0800LC140	F0400LC140	1400	775	7630	291×10^3	380	1.1	200	800	1000	1.494	0.692	125	0.032	W4
F0800LC180	F0400LC180	1800	775	7630	291×10^3	380	1.1	200	800	1000	1.494	0.692	125	0.032	W4
F0900VC450	FX055VC450	4500	816	10450	546×10^3	3000	1.4	2000	900	2000	2.024	1.274	115	0.016	W6
F0900VC520	FX055VC520	5200	816	10450	546×10^3	3000	1.4	2000	900	2000	2.024	1.274	115	0.016	W6
F0900VF450	FX055VF450	4500	816	10450	546×10^3	3000	1.4	2000	900	2000	2.024	1.274	115	0.016	W43
F0900VF520	FX055VF520	5200	816	10450	546×10^3	3000	1.4	2000	900	2000	2.024	1.274	115	0.016	W43
F1000LC080	F0500LC080	800	826	8500	361×10^3	320	1.6	250	1000	800	1.530	0.547	125	0.032	W4
F1000LC120	F0500LC120	1200	826	8500	361×10^3	320	1.6	250	1000	800	1.530	0.547	125	0.032	W4
F1400NC140	FX004NC140	1400	1093	17250	1.49×10^6	800	1.5	600	1400	1000	1.618	0.388	125	0.024	W5
F1400NC180	FX004NC180	1800	1093	17250	1.49×10^6	800	1.5	600	1400	1000	1.618	0.388	125	0.024	W5
F1500NC200	FX056NC200	2000	1054	13750	950×10^3	1065	1.5	800	1500	2000	1.372	0.535	125	0.024	W5
F1500NC250	FX056NC250	2500	1054	13750	950×10^3	1065	1.5	800	1500	2000	1.372	0.535	125	0.024	W5
F1600NC080	FX021NC080	800	1326	20000	2.0×10^6	480	2.3	550	1600	800	1.320	0.268	125	0.024	W5
F1600NC120	FX021NC120	1200	1326	20000	2.0×10^6	480	2.3	550	1600	800	1.320	0.268	125	0.024	W5



Fig. W1 - 70 g



Fig. W2 - 80 g



Fig. W3 - 140 g



Fig. W4 - 340 g



Fig. W5 - 510 g



Fig. W6 - 1000 g



Fig. W43 - 800 g

High Power Sonic-FRDs™ - Capsule Types

Introducing a new world-leading class of ultra fast and ultra soft recovery diode available from 1.7kV to 4.5kV in current ratings from 300 to 2500A. These diodes incorporate a unique manufacturing process and novel lifetime control to offer a class leading trade-off between conduction and switching losses. Their exceptionally wide safe operating area (SOA) makes

them the number one choice for freewheeling diodes for snubberless IGBT and IGCT applications. In fact, most applications which require a fast, low loss diode can benefit from this new technology - for example, traction, medium voltage drives, induction heating and pulsed power applications.

Type		V _{RRM} V	I _{FAV} T _c = 55°C A	I _{FSM} 10ms ½ sine V _R ≤ 60% V _{RRM} A	I ² t V _R ≤ 60% V _{RRM} A ² s	Typ. Reverse Recovery Parameters					V _{TO} @T _j max V	r _T mΩ	T _j max °C	R _{thJK} 180° Sine K/W	Fig. No.
Part No.	Old Part No.					T _j max(50% Chord)									
						I _{rm} A	t _{rr} μs	Q _r μC	@I _{FM} A	@-di _p /dt A/μs					
E0300YH400	N/A	4000	277	2630	34.58 × 10 ³	605	0.75	245	300	2000	2.170	3.800	150	0.073	W3
E0300YH450	N/A	4500	277	2630	34.58 × 10 ³	605	0.75	245	300	2000	2.170	3.800	150	0.073	W3
E0400YH200	N/A	2000	348	3542	62.7 × 10 ³	572	0.74	175	400	1500	1.770	2.290	150	0.073	W3
E0400YH250	N/A	2500	348	3542	62.7 × 10 ³	572	0.74	175	400	1500	1.770	2.290	150	0.073	W3
E0900NC400	N/A	4000	969	15270	1.17 × 10 ⁶	1340	2.20	1440	900	2000	2.140	1.150	150	0.020	W5
E0900NC450	N/A	4500	969	15270	1.17 × 10 ⁶	1340	2.20	1440	900	2000	2.140	1.150	150	0.020	W5
E1500NC200	N/A	2000	1557	15180	1.15 × 10 ⁶	1450	2.30	1550	1500	2000	1.670	0.360	150	0.020	W5
E1500NC250	N/A	2500	1557	15180	1.15 × 10 ⁶	1450	2.30	1550	1500	2000	1.670	0.360	150	0.020	W5
E1500VF400	N/A	4000	1995	23600	2.78 × 10 ⁶	1730	3.00	2700	1500	2000	2.350	0.270	150	0.013	W6
E1500VF450	N/A	4500	1995	23600	2.78 × 10 ⁶	1730	3.00	2700	1500	2000	2.350	0.270	150	0.013	W6
E2000NC140	N/A	1400	1568	16500	1.13 × 10 ⁶	1880	1.00	950	2000	4000	1.770	0.350	150	0.020	W5
E2000NC170	N/A	1700	1568	16500	1.13 × 10 ⁶	1880	1.00	950	2000	4000	1.770	0.350	150	0.020	W5
E2500VF200	N/A	2000	2516	28600	4.10 × 10 ⁶	1750	1.40	1350	2500	3000	1.630	0.210	150	0.013	W6
E2500VF250	N/A	2500	2516	28600	4.10 × 10 ⁶	1750	1.40	1350	2500	3000	1.630	0.210	150	0.013	W6
EX175TC400	N/A	4000	Product Under Development										150	0.008	W28
EX175TC450	N/A	4500	Product Under Development										150	0.008	W28

Under development



Fig. W3
Weight 140 g



Fig. W5
Weight 510 g



Fig. W6
Weight 1000 g



Fig. W7
Weight 1700 g

We provide one of the most comprehensive ranges of standard phase control thyristors available in the Industry.

Devices with voltage ranges from 600V up to 4.5kV are available, making them suitable for applications with line voltages from 230V to over 1kV (higher voltage applications are now served by our range of Medium Voltage Thyristors).

Westcode is a leading supplier of phase control products into demanding markets such as industrial DC drives, induction melting, marine/rail propulsion systems, wind power converters, electrochemical power supplies and soft starters.

These devices are optimised to give low conduction losses and are primarily intended for applications from line frequency up to 400Hz.

Phase Control Thyristors - Stud Types

Type		V_{DRM} / V_{RRM} V	I_{TAV} $T_K = 55^\circ C$ A	I_{TSM} 10ms 1/2 sine $V_R = 60\% V_{RRM}$ A	I^2t $V_R = 60\%$ V_{RRM} A^2s	V_{TO} r_T @ T_{jmax}		T_{jmax} °C	R_{thJC}		Fig. No.
► New Part No.	Old Part No.					V	mΩ		d.c. 180° sine K/W	120° Rect. K/W	
N0131SH120	N086PH12	1200	131	1700	14×10^3	1.570	2.290	125	0.23	0.28	W17
N0131SH160	N086PH16	1600	131	1700	14×10^3	1.570	2.290	125	0.23	0.28	W17
► N0131SJ120	N/A	1200	131	1700	14×10^3	1.570	2.290	125	0.23	0.28	W16
► N0131SJ160	N/A	1600	131	1700	14×10^3	1.570	2.290	125	0.23	0.28	W16
N0180SH120	N105PH12	1200	180	2450	30×10^3	0.900	1.790	125	0.23	0.28	W17
N0180SH160	N105PH16	1600	180	2450	30×10^3	0.900	1.790	125	0.23	0.28	W17
► N0180SJ120	N/A	1200	180	2450	30×10^3	0.900	1.790	125	0.23	0.28	W16
► N0180SJ160	N/A	1600	180	2450	30×10^3	0.900	1.790	125	0.23	0.28	W16
N0290SC120	N170PH12	1200	290	4200	88.2×10^3	1.080	1.300	125	0.12	0.14	W18
N0290SC160	N170PH16	1600	290	4200	88.2×10^3	1.080	1.300	125	0.12	0.14	W18
► N0290SG120	N/A	1200	290	4200	88.2×10^3	1.080	1.300	125	0.12	0.14	W25
► N0290SG160	N/A	1600	290	4200	88.2×10^3	1.080	1.300	125	0.12	0.14	W25
N0335SC120	N195PH12	1200	335	4650	108×10^3	0.920	0.990	125	0.12	0.14	W18
N0335SC160	N195PH16	1600	335	4650	108×10^3	0.920	0.990	125	0.12	0.14	W18
► N0335SG120	N/A	1200	335	4650	108×10^3	0.920	0.990	125	0.12	0.14	W25
► N0335SG160	N/A	1600	335	4650	108×10^3	0.920	0.990	125	0.12	0.14	W25
N0416SC020	N275PH02	200	416	6000	180×10^3	0.850	0.535	125	0.12	0.14	W18
N0416SC080	N275PH08	800	416	6000	180×10^3	0.850	0.535	125	0.12	0.14	W18
► N0416SG020	N/A	200	416	6000	180×10^3	0.850	0.535	125	0.12	0.14	W25
► N0416SG080	N/A	800	416	6000	180×10^3	0.850	0.535	125	0.12	0.14	W25



Fig. W16
Weight 100 g



Fig. W17
Weight 130 g

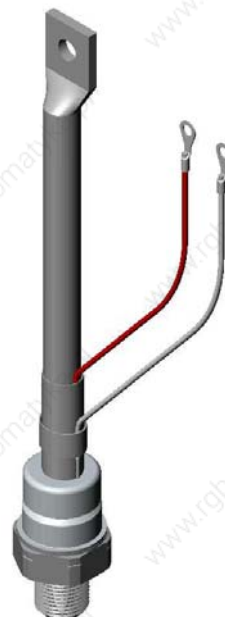

Fig. W18
Weight 250 g



Fig. W25
Weight 220g

The WespacK outline is a new concept in phase control thyristors for applications requiring devices rated to 2200V. It gives the maximum power rating for weight and volume without compromising on quality and reliability. It also gives the maximum current rating and lowest thermal resistance for the package size.

WESPACK Phase Control Thyristors - Capsule Types

Type		V_{DRM} / V_{RRM}	I_{TAV}	I_{TSM}	I^2t	V_{TO}	r_T	T_{jmax}	R_{thJK}		Fig. No.	
Part No.	Old Part No.	V	TK=55°C A	10ms ½ sine $V_R \leq 60\% V_{RRM}$ A	$V_R \leq 60\%$ V_{RRM} A ² s	V	@ T_{jmax} mΩ	°C	d.c. 180° sine K/W	120° Rect. K/W		
NX159JK200	n/a	2000	Product under development - Refer to Westcode factory									WP1
NX159JK220	n/a	2200	Product under development - Refer to Westcode factory									WP1
NX159JK160	n/a	1600	Product under development - Refer to Westcode factory									WP1
NX159JK180	n/a	1800	Product under development - Refer to Westcode factory									WP1
NX159JK120	n/a	1200	Product under development - Refer to Westcode factory									WP1
NX159JK140	n/a	1400	Product under development - Refer to Westcode factory									WP1
NX159JK020	n/a	200	Product under development - Refer to Westcode factory									WP1
NX159JK060	n/a	600	Product under development - Refer to Westcode factory									WP1
N1651QK200	n/a	2000	1651	17300	1.50×10^6	1.060	0.317	125	0.018	0.0217	WP2	
N1651QK220	n/a	2200	1651	17300	1.50×10^6	1.060	0.317	125	0.018	0.0217	WP2	
N1806QK160	n/a	1600	1806	19100	1.82×10^6	1.022	0.253	125	0.018	0.0217	WP2	
N1806QK180	n/a	1800	1806	19100	1.82×10^6	1.022	0.253	125	0.018	0.0217	WP2	
N2083QK080	n/a	800	2083	22000	2.42×10^6	0.955	0.177	125	0.018	0.0217	WP2	
N2083QK140	n/a	1400	2083	22000	2.42×10^6	0.955	0.177	125	0.018	0.0217	WP2	
NX155QK020	n/a	200	Product under development - Refer to Westcode factory									WP2
NX155QK060	n/a	600	Product under development - Refer to Westcode factory									WP2
N2367MK200	n/a	2000	2367	32400	5.25×10^6	0.883	0.210	125	0.014	0.0157	WP3	
N2367MK220	n/a	2200	2367	32400	5.25×10^6	0.883	0.210	125	0.014	0.0157	WP3	
N2593MK160	n/a	1600	2593	34500	5.95×10^6	0.940	0.154	125	0.014	0.0157	WP3	
N2593MK180	n/a	1800	2593	34500	5.95×10^6	0.940	0.154	125	0.014	0.0157	WP3	
NX149MK120	n/a	1200	Product under development - Refer to Westcode factory									WP3
NX149MK140	n/a	1400	Product under development - Refer to Westcode factory									WP3
N4004MK020	n/a	200	4004	45400	10.3×10^6	0.990	0.053	125	0.014	0.0157	WP3	
N4004MK060	n/a	600	4004	45400	10.3×10^6	0.990	0.053	125	0.014	0.0157	WP3	
NX160HK200	n/a	2000	Product under development - Refer to Westcode factory									WP4
NX160HK220	n/a	2200	Product under development - Refer to Westcode factory									WP4
N4472HK160	n/a	1600	4472	59000	17.40×10^6	0.986	0.068	125	0.009	0.0099	WP4	
N4472HK180	n/a	1800	4472	59000	17.40×10^6	0.986	0.068	125	0.009	0.0099	WP4	
NX160HK120	n/a	1200	Product under development - Refer to Westcode factory									WP4
NX160HK140	n/a	1400	Product under development - Refer to Westcode factory									WP4
NX157HK020	n/a	200	Product under development - Refer to Westcode factory									WP4
NX157HK060	n/a	600	Product under development - Refer to Westcode factory									WP4



Fig. WP1
Weight 180 g



Fig. WP2
Weight 200 g



Fig. WP3
Weight 260 g



Fig. WP4
Weight 550 g

Under development

Phase Control Thyristors - Capsule Types

Type		V_{DRM} / V_{RRM}	I_{TAV} $T_K=55^\circ C$	I_{TSM} 10ms 1/2 sine $V_R \leq 60\% V_{RRM}$	I^2t $V_R \leq 60\%$ V_{RRM} A^2s	V_{TO} r_T @ T_{jmax}		T_{jmax} °C	R_{thJK}		Fig. No.
Part No.	Old Part No.					V	A		V	mΩ	
N0194WC120	N086CH12	1200	194	1700	14.5×10^3	1.570	2.290	125	0.135	0.190	W8
N0194WC160	N086CH16	1600	194	1700	14.5×10^3	1.570	2.290	125	0.135	0.190	W8
N0255WC120	N105CH12	1200	255	2450	30.0×10^3	0.900	1.790	125	0.135	0.190	W8
N0255WC160	N105CH16	1600	255	2450	30.0×10^3	0.900	1.790	125	0.135	0.190	W8
N0339WC120	N170CH12	1200	339	4200	88.2×10^3	1.080	1.300	125	0.095	0.110	W8
N0339WC160	N170CH16	1600	339	4200	88.2×10^3	1.080	1.300	125	0.095	0.110	W8
N0392WC120	N195CH12	1200	392	4650	108×10^3	0.920	0.990	125	0.095	0.110	W8
N0392WC160	N195CH16	1600	392	4650	108×10^3	0.920	0.990	125	0.095	0.110	W8
N0491WC020	N275CH02	200	491	6000	180×10^3	0.850	0.535	125	0.095	0.110	W8
N0491WC080	N275CH08	800	491	6000	180×10^3	0.850	0.535	125	0.095	0.110	W8
N0606YS200	N282SH20	2000	606	7100	252×10^3	1.103	0.804	125	0.050	0.058	W9
N0606YS250	N/A	2500	606	7100	252×10^3	1.103	0.804	125	0.050	0.058	W9
N0616LC400	N255CH40	4000	616	5250	138×10^3	1.220	1.530	125	0.032	0.040	W10
N0616LC450	N255CH45	4500	616	5250	138×10^3	1.220	1.530	125	0.032	0.040	W10
N0634LC380	N257CH38	3800	634	7000	245×10^3	1.100	1.500	125	0.032	0.040	W10
N0634LC420	N257CH42	4200	634	7000	245×10^3	1.100	1.500	125	0.032	0.040	W10
N0646LC300	N260CH30	3000	646	5700	162×10^3	1.210	1.360	125	0.032	0.040	W10
N0646LC360	N260CH36	3600	646	5700	162×10^3	1.210	1.360	125	0.032	0.040	W10
N0676YS120	N281SH12	1200	676	7500	281×10^3	1.090	0.587	125	0.050	0.058	W9
N0676YS180	N281SH18	1800	676	7500	281×10^3	1.090	0.587	125	0.050	0.058	W9
N0734YS120	N280SH12	1200	734	8400	353×10^3	1.030	0.483	125	0.050	0.058	W9
N0734YS160	N280SH16	1600	734	8400	353×10^3	1.030	0.483	125	0.050	0.058	W9
N0782YS120	N283SH12	1200	782	9420	444×10^3	0.920	0.450	125	0.050	0.058	W9
N0782YS140	N283SH14	1600	782	9420	444×10^3	0.920	0.450	125	0.050	0.058	W9
N0882NC400	N320CH40	4000	882	7700	296×10^3	1.300	0.920	125	0.024	0.030	W11
N0882NC450	N320CH45	5000	882	7700	296×10^3	1.300	0.920	125	0.024	0.030	W11
N0910LS200	N330SH20	2000	910	9200	423×10^3	1.040	0.606	125	0.032	0.040	W10a
N0910LS260	N330SH26	2600	910	9200	423×10^3	1.040	0.606	125	0.032	0.040	W10a
N0992YS020	N310SH02	200	992	11000	605×10^3	0.820	0.240	125	0.050	0.058	W9
N0992YS060	N310SH06	600	992	11000	605×10^3	0.820	0.240	125	0.050	0.058	W9
N1010NC300	N360CH30	3000	1010	12100	732×10^3	1.170	0.687	125	0.024	0.030	W11
N1010NC380	N360CH38	3800	1010	12100	732×10^3	1.170	0.687	125	0.024	0.030	W11
N1042LS120	N350SH12	1200	1042	11500	661×10^3	1.080	0.395	125	0.032	0.040	W10a
N1042LS180	N350SH18	1800	1042	11500	661×10^3	1.080	0.395	125	0.032	0.040	W10a
N1114LS120	N370SH12	1200	1114	12700	806×10^3	1.000	0.349	125	0.032	0.040	W10a
N1114LS180	N370SH18	1800	1114	12700	806×10^3	1.000	0.349	125	0.032	0.040	W10a
N1132NC300	N390CH30	3000	1132	14300	1.02×10^6	1.150	0.510	125	0.024	0.030	W11
N1132NC320	N390CH32	3200	1132	14300	1.02×10^6	1.150	0.510	125	0.024	0.030	W11
N1159NC380	N500CH38	3800	1159	14500	1.05×10^6	1.100	0.574	125	0.022	0.027	W11
N1159NC420	N500CH42	4200	1159	14500	1.05×10^6	1.100	0.574	125	0.022	0.027	W11
N1265LS120	N520SH12	1200	1265	15000	1.13×10^6	0.900	0.265	125	0.032	0.040	W10a
N1265LS150	N520SH15	1500	1265	15000	1.13×10^6	0.900	0.265	125	0.032	0.040	W10a
N1297NS200	N450SH20	2000	1297	17600	1.55×10^6	1.030	0.380	125	0.024	0.030	W11a
N1297NS260	N450SH26	2600	1297	17600	1.55×10^6	1.030	0.380	125	0.024	0.030	W11a
N1314NC300	N570CH30	3000	1314	16600	1.38×10^6	1.000	0.437	125	0.024	0.030	W11
N1314NC360	N570CH36	3600	1314	16600	1.38×10^6	1.000	0.437	125	0.024	0.030	W11
N1351VC400	N560CH40	4000	1351	17500	1.53×10^6	1.200	0.553	125	0.017	0.020	W12
N1351VC450	N560CH45	4500	1351	17500	1.53×10^6	1.200	0.553	125	0.017	0.020	W12
N1351VD400	N/A	4000	1351	17500	1.53×10^6	1.200	0.553	125	0.017	0.020	W50
N1351VD450	N/A	4500	1351	17500	1.53×10^6	1.200	0.553	125	0.017	0.020	W50
N1467NS200	N490SH20	2000	1467	21500	2.31×10^6	1.000	0.272	125	0.024	0.030	W11a
N1467NS260	N490SH26	2600	1467	21500	2.31×10^6	1.000	0.272	125	0.024	0.030	W11a
N1479NS240	N620SH24	2400	1436	21000	2.21×10^6	1.000	0.342	125	0.022	0.026	W11a
N1479NS300	N620SH30	3000	1436	21000	2.21×10^6	1.000	0.342	125	0.022	0.026	W11a
N1547NS160	N510SH16	1600	1547	23300	2.71×10^6	0.920	0.252	125	0.024	0.030	W11a
N1547NS200	N510SH20	2000	1547	23300	2.71×10^6	0.920	0.252	125	0.024	0.030	W11a
N1588NS200	N680SH20	2000	1588	22500	2.53×10^6	0.951	0.268	125	0.022	0.027	W11a
N1588NS260	N680SH26	2600	1588	22500	2.53×10^6	0.951	0.268	125	0.022	0.027	W11a

Phase Control Thyristors - Capsule Types, continued

Type		V_{DRM} / V_{RRM}	I_{TAV} $T_K=55^\circ C$	I_{TSM} 10ms 1/2 sine $V_R \leq 60\% V_{RRM}$	I^2t $V_R \leq 60\%$ V_{RRM} A ² s	V_{T0} r_T @ T_{jmax}	$T_{i max}$	R_{thJK}		Fig. No.	
Part No.	Old Part No.	V	A	A	A ² s	V	mΩ	°C	180° Sine K/W	120° Rect. K/W	
N1661VC300	N630CH30	3000	1661	23000	2.65×10^6	1.040	0.350	125	0.017	0.020	W12
N1661VC360	N630CH36	3600	1661	23000	2.65×10^6	1.040	0.350	125	0.017	0.020	W12
N1661VD300	N/A	3000	1661	23000	2.65×10^6	1.040	0.350	125	0.017	0.020	W50
N1661VD360	N/A	3600	1661	23000	2.65×10^6	1.040	0.350	125	0.017	0.020	W50
N1712VC240	N640CH24	2400	1712	24500	3.00×10^6	1.050	0.320	125	0.017	0.020	W12
N1712VC300	N640CH30	3000	1712	24500	3.00×10^6	1.050	0.320	125	0.017	0.020	W12
N1712VD240	N/A	2400	1712	24500	3.00×10^6	1.050	0.320	125	0.017	0.020	W50
N1712VD300	N/A	3000	1712	24500	3.00×10^6	1.050	0.320	125	0.017	0.020	W50
N1718NS120	N540SH12	1200	1718	27200	3.70×10^6	0.979	0.169	125	0.024	0.030	W11a
N1718NS180	N540SH18	1800	1718	27200	3.70×10^6	0.979	0.169	125	0.024	0.030	W11a
N1802NS120	N600SH12	1200	1802	29600	4.38×10^6	0.855	0.171	125	0.024	0.030	W11a
N1802NS160	N600SH16	1600	1802	29600	4.38×10^6	0.855	0.171	125	0.024	0.030	W11a
N2046NS120	N740SH12	1200	2046	29200	4.26×10^6	0.980	0.114	125	0.022	0.026	W11a
N2046NS160	N740SH16	1600	2046	29200	4.26×10^6	0.980	0.114	125	0.022	0.026	W11a
N2086NS060	N610SH06	600	2086	35000	6.13×10^6	0.840	0.108	125	0.024	0.030	W11a
N2086NS100	N610SH10	1000	2086	35000	6.13×10^6	0.840	0.108	125	0.024	0.030	W11a
N2172ZC400	N750CH40	4000	2172	28000	3.92×10^6	1.350	0.294	125	0.011	0.012	W13
N2172ZC450	N750CH45	4500	2172	28000	3.92×10^6	1.350	0.294	125	0.011	0.012	W13
N2172ZD400	N750DH40	4000	2172	28000	3.92×10^6	1.350	0.294	125	0.011	0.012	W46
N2172ZD450	N750DH45	4500	2172	28000	3.92×10^6	1.350	0.294	125	0.011	0.012	W46
N2293VC180	N760CH18	1800	2293	33800	5.71×10^6	0.956	0.148	125	0.017	0.020	W12
N2293VC220	N760CH22	2200	2293	33800	5.71×10^6	0.956	0.148	125	0.017	0.020	W12
N2293VD180	N/A	1800	2293	33800	5.71×10^6	0.956	0.148	125	0.017	0.020	W50
N2293VD220	N/A	2200	2293	33800	5.71×10^6	0.956	0.148	125	0.017	0.020	W50
N2418ZC300	N850CH30	3000	2418	30000	4.50×10^6	1.160	0.246	125	0.011	0.012	W13
N2418ZC360	N850CH36	3600	2418	30000	4.50×10^6	1.160	0.246	125	0.011	0.012	W13
N2418ZD300	N/A	3000	2418	30000	4.50×10^6	1.160	0.246	125	0.011	0.012	W46
N2418ZD360	N/A	3600	2418	30000	4.50×10^6	1.160	0.246	125	0.011	0.012	W46
N2500VC120	N990CH12	1200	2500	37000	6.85×10^6	0.880	0.124	125	0.017	0.020	W12
N2500VC160	N990CH16	1600	2500	37000	6.85×10^6	0.880	0.124	125	0.017	0.020	W12
N2500VD120	N/A	1200	2500	37000	6.85×10^6	0.880	0.124	125	0.017	0.020	W50
N2500VD160	N/A	1600	2500	37000	6.85×10^6	0.880	0.124	125	0.017	0.020	W50
N2543ZC240	N880CH24	2400	2543	32000	5.12×10^6	0.780	0.274	125	0.011	0.012	W13
N2543ZC300	N880CH30	3000	2543	32000	5.12×10^6	0.780	0.274	125	0.011	0.012	W13
N2543ZD240	N/A	2400	2543	32000	5.12×10^6	0.780	0.274	125	0.011	0.012	W46
N2543ZD300	N/A	3000	2543	32000	5.12×10^6	0.780	0.274	125	0.011	0.012	W46
N3012ZC200	N900CH20	2000	3012	45100	10.2×10^6	0.920	0.160	125	0.011	0.012	W13
N3012ZC260	N900CH26	2600	3012	45100	10.2×10^6	0.920	0.160	125	0.011	0.012	W13
N3012ZD200	N/A	2000	3012	45100	10.2×10^6	0.920	0.160	125	0.011	0.012	W46
N3012ZD260	N/A	2600	3012	45100	10.2×10^6	0.920	0.160	125	0.011	0.012	W46
N3476TC360	N1463CH36	3600	3476	46800	10.95×10^6	0.970	0.180	125	0.008	0.009	W14
N3476TC420	N1463CH42	4200	3476	46800	10.95×10^6	0.970	0.180	125	0.008	0.009	W14
N3476TD360	N1463DH36	3600	3476	46800	10.95×10^6	0.970	0.180	125	0.008	0.009	W19
N3476TD420	N1463DH42	4200	3476	46800	10.95×10^6	0.970	0.180	125	0.008	0.009	W19
N3533ZC140	N1400CH14	1400	3533	50000	12.50×10^6	0.970	0.095	125	0.011	0.012	W13
N3533ZC220	N1400CH22	2200	3533	50000	12.50×10^6	0.970	0.095	125	0.011	0.012	W13
N3533ZD140	N/A	1400	3533	50000	12.50×10^6	0.970	0.095	125	0.011	0.012	W46
N3533ZD220	N/A	2200	3533	50000	12.50×10^6	0.970	0.095	125	0.011	0.012	W46
N3839TC300	N1663CH30	3000	3839	49500	12.25×10^6	0.950	0.140	125	0.008	0.012	W14
N3839TC350	N1663CH35	3500	3839	49500	12.25×10^6	0.950	0.140	125	0.008	0.012	W14
N3839TD300	N1663DH30	3000	3839	49500	12.25×10^6	0.950	0.140	125	0.008	0.012	W19
N3839TD350	N1663DH35	3500	3839	49500	12.25×10^6	0.950	0.140	125	0.008	0.012	W19
N4085ZC080	N1600CH08	800	4085	64000	20.5×10^6	0.850	0.070	125	0.011	0.012	W13
N4085ZC120	N1600CH12	1200	4085	64000	20.5×10^6	0.850	0.070	125	0.011	0.012	W13
N4085ZD080	N/A	800	4085	64000	20.5×10^6	0.850	0.070	125	0.011	0.012	W46
N4085ZD120	N/A	1200	4085	64000	20.5×10^6	0.850	0.070	125	0.011	0.012	W46

Phase Control Thyristors - Capsule Types, continued

Type		V_{DRM} / V_{RRM}	I_{TAV} $T_K=55^\circ\text{C}$	I_{TSM} 10ms 1/2 sine $V_R \leq 60\% V_{RRM}$	I^2t $V_R \leq 60\%$ V_{RRM} A^2s	V_{TO} $@ T_{jmax}$	r_T	T_{jmax}	R_{thJK}		Fig. No.
Part No.	Old Part No.	V	A	A		V	mΩ	°C	180° Sine K/W	120° Rect. K/W	
N4151FC360	N1483CH36	3600	4151	54000	14.6×10^6	0.850	0.170	125	0.0065	0.0068	W15
N4151FC420	N1483CH42	4200	4151	54000	14.6×10^6	0.850	0.170	125	0.0065	0.0068	W15
N4151FD360	N1483DH36	3600	4151	54000	14.6×10^6	0.850	0.170	125	TBC	TBC	W48
N4151FD420	N1483DH42	4200	4151	54000	14.6×10^6	0.850	0.170	125	TBC	TBC	W48
N4400TC120	N1863CH12	1200	4400	54000	14.6×10^6	0.900	0.100	125	0.008	0.0085	W14
N4400TC220	N1863CH22	2200	4400	54000	14.6×10^6	0.900	0.100	125	0.008	0.0085	W14
N4400TC280	N1863CH28	2800	4400	54000	14.6×10^6	0.900	0.100	125	0.008	0.0085	W14
N4400TD120	N1863DH12	1200	4400	54000	14.6×10^6	0.900	0.100	125	0.008	0.0085	W19
N4400TD220	N1863DH22	2200	4400	54000	14.6×10^6	0.900	0.100	125	0.008	0.0085	W19
N4400TD280	N1863DH28	2800	4400	54000	14.6×10^6	0.900	0.100	125	0.008	0.0085	W19
N4803FC300	N1683CH30	3000	4803	60000	18.0×10^6	0.920	0.110	125	0.0065	0.0068	W15
N4803FC350	N1683CH35	3500	4803	60000	18.0×10^6	0.920	0.110	125	0.0065	0.0068	W15
N4803FD300	N/A	3000	4803	60000	18.0×10^6	0.920	0.110	125	TBC	TBC	W48
N4803FD350	N/A	3500	4803	60000	18.0×10^6	0.920	0.110	125	TBC	TBC	W48
N5177FC200	N1883CH20	2000	5177	67500	22.8×10^6	0.800	0.100	125	0.0065	0.0068	W15
N5177FC280	N1883CH28	2800	5177	67500	22.8×10^6	0.800	0.100	125	0.0065	0.0068	W15
N5177FD200	N/A	2000	5177	67500	22.8×10^6	0.800	0.100	125	TBC	TBC	W48
N5177FD280	N/A	2800	5177	67500	22.8×10^6	0.800	0.100	125	TBC	TBC	W48
N5946FC180	N1983CH18	1800	5946	72000	25.9×10^6	0.855	0.065	125	0.0065	0.0068	W15
N5946FC220	N1983CH22	2200	5946	72000	25.9×10^6	0.855	0.065	125	0.0065	0.0068	W15
N5946FD180	N/A	1800	5946	72000	25.9×10^6	0.855	0.065	125	TBC	TBC	W48
N5946FD220	N/A	2200	5946	72000	25.9×10^6	0.855	0.065	125	TBC	TBC	W48



Fig. W8
Weight 70 g



Fig. W9
Weight 90 g



Fig. W10
Weight 340 g



Fig. W10a
Weight 340 g



Fig. W11
Weight 510 g



Fig. W11a
Weight 510 g



Fig. W12
Weight 1000 g



Fig. W13
Weight 1700 g



Fig. W14
Weight 1300 g



Fig. W15
Weight 2800 g

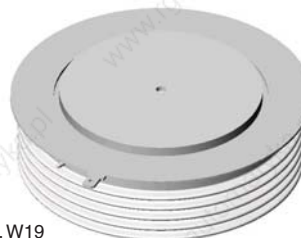

Fig. W19
Weight 1700 g

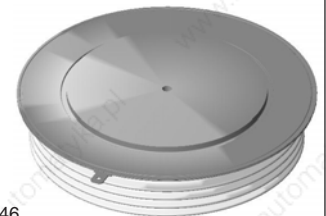

Fig. W46
Weight 1200 g



Fig. W48
Weight 1200 g

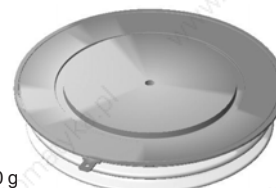

Fig. W50
Weight 750 g

Medium voltage applications place additional demands on phase controlled thyristors. To meet these demands we have developed a comprehensive range of thyristors optimised for medium voltage applications. As voltages increase, so do switching losses and turn-off time – to a point where they become significant in line frequency applications.

Medium voltage thyristors are available from 3.2 kV up to 6.5 kV with silicon diameters from 38 mm to 100 mm making them particularly suitable for high power converters such as medium voltage DC drives, medium voltage soft starts and utility applications such as HVDC, static VAR compensators, excitation and transfer switches.

Our patented distributed gate architecture ensures excellent switching performance over a wide range of voltage, current and di/dt. Device lifetime is also engineered to achieve an optimum balance between conduction losses, commutation losses and turn off time to give maximum power handling from line frequency to 400 Hz. This also gives significant benefits when series or parallel connection of devices is required.

We recognise the importance of reliability in these large, capital intensive applications and as a result we subject these parts to extended levels of both routine and type testing to ensure that your investment gives years of trouble free service.

Medium Voltage Thyristors - Capsule Types

Under development

Type		V _{DRM} / V _{RRM} V	I _{TAV} T _{K=55°C} A	I _{TSM} 10ms ½ sine V _R ≤ 60% V _{RRM} A	I ² t V _{RRM} ≤ 60% A ² s	t _q @ 200V/µs µs	Typ. Reverse Recovery Charge T _j max, 50% Chord			V _{TO} V	r _T mΩ	T _j max °C	R _{thJK}		Fig. No.
> New Part No.	Old Part No.						Q _{ra} µC	@ I _{TM} A	@ -di/dt A/µs				180° Sine K/W	120° Rect. K/W	
K0349LC600	P201CH60	6000	349	4800	115 x 10 ³	900-1200	900	1000	60	1.568	2.428	115	0.047	0.049	W10
K0349LC650	P201CH65	6500	349	4800	115 x 10 ³	900-1200	900	1000	60	1.568	2.428	115	0.047	0.049	W10
K0769NC600	P410CH60	6000	769	8600	370 x 10 ³	900-1200	2050	1000	10	1.566	1.172	115	0.024	0.029	W11
K0769NC650	P410CH65	6500	769	8600	370 x 10 ³	900-1200	2050	1000	10	1.566	1.172	115	0.024	0.029	W11
K0890NC360	R295CH36	3600	890	10900	594 x 10 ³	350-550	1500	1000	10	1.516	0.800	125	0.024	0.029	W11
K0890NC420	R295CH42	4200	890	10900	594 x 10 ³	350-550	1500	1000	10	1.516	0.800	125	0.024	0.029	W11
K1121NC320	P440CH32	3200	1121	15000	1.13 x 10 ⁶	400-500	1000	1000	10	1.098	0.542	125	0.024	0.029	W11
K1121NC360	P440CH36	3600	1121	15000	1.13 x 10 ⁶	400-500	1000	1000	10	1.098	0.542	125	0.024	0.029	W11
K1197NC300	P480CH30	3000	1197	10646	567 x 10 ³	200-300	1400	1000	10	1.210	0.430	125	0.024	0.029	W11
K1197NC320	P480CH32	3200	1197	10646	567 x 10 ³	200-300	1400	1000	10	1.210	0.430	125	0.024	0.029	W11
> K1351VC600	N/A	6000	1351	14300	1.02 x 10 ⁶	800-1500	4500	2000	10	1.410	0.600	115	0.013	0.014	W12
> K1351VC650	N/A	6500	1351	14300	1.02 x 10 ⁶	800-1500	4500	2000	10	1.410	0.600	115	0.013	0.014	W12
> K1351VF600	N/A	6000	1351	14300	1.02 x 10 ⁶	800-1500	4500	2000	10	1.410	0.600	115	0.013	0.014	W50
> K1351VF650	N/A	6500	1351	14300	1.02 x 10 ⁶	800-1500	4500	2000	10	1.410	0.600	115	0.013	0.014	W50
K1947ZC400	P855CH40	4000	1947	25000	3.13 x 10 ⁶	600-700	3500	1000	10	1.221	0.425	125	0.011	0.012	W13
K1947ZC450	P855CH45	4500	1947	25000	3.13 x 10 ⁶	600-700	3500	1000	10	1.221	0.425	125	0.011	0.012	W13
K1947ZD400	P855CH40	4000	1947	25000	3.13 x 10 ⁶	600-700	3500	1000	10	1.221	0.425	125	0.011	0.012	W46
K1947ZD450	P855CH45	4500	1947	25000	3.13 x 10 ⁶	600-700	3500	1000	10	1.221	0.425	125	0.011	0.012	W46
K2095ZC360	P880CH36	3600	2095	18200	1.66 x 10 ⁶	400-500	2400	2000	10	1.502	0.296	125	0.011	0.012	W13
K2095ZC420	P880CH42	4200	2095	18200	1.66 x 10 ⁶	400-500	2400	2000	10	1.502	0.296	125	0.011	0.012	W13
K2095ZD360	P880DH36	3600	2095	18200	1.66 x 10 ⁶	400-500	2400	2000	10	1.502	0.296	125	0.011	0.012	W46
K2095ZD420	P880DH42	4200	2095	18200	1.66 x 10 ⁶	400-500	2400	2000	10	1.502	0.296	125	0.011	0.012	W46
K2359TC600	P1063CH60	6000	2359	27000	3.65 x 10 ⁶	1100-1500	6800	2000	10	1.391	0.360	115	0.0085	0.009	W14
K2359TC650	P1063CH65	6500	2359	27000	3.65 x 10 ⁶	1100-1500	6800	2000	10	1.391	0.360	115	0.0085	0.009	W14
K2359TD600	N/A	6000	2359	27000	3.65 x 10 ⁶	1100-1500	6800	2000	10	1.391	0.360	115	0.0085	0.009	W19
K2359TD650	N/A	6500	2359	27000	3.65 x 10 ⁶	1100-1500	6800	2000	10	1.391	0.360	115	0.0085	0.009	W19
K2623TC450	R1263CH45	4500	2623	27000	3.65 x 10 ⁶	500-1000	2600	2000	60	1.421	0.295	125	0.008	0.009	W14
K2623TC520	R1263CH52	5200	2623	27000	3.65 x 10 ⁶	500-1000	2600	2000	60	1.421	0.295	125	0.008	0.009	W14
K2623TD450	N/A	4500	2623	27000	3.65 x 10 ⁶	500-1000	2600	2000	60	1.421	0.295	125	0.008	0.009	W19
K2623TD520	N/A	5200	2623	27000	3.65 x 10 ⁶	500-1000	2600	2000	60	1.421	0.295	125	0.008	0.009	W19
K2960TC450	N/A	4500	2960	32500	5.28 x 10 ⁶	800-1600	11000	4000	10	1.229	0.212	125	0.0085	0.009	W14
K2960TC520	N/A	5200	2960	32500	5.28 x 10 ⁶	800-1600	11000	4000	10	1.229	0.212	125	0.0085	0.009	W14
K2960TD450	N/A	4500	2960	32500	5.28 x 10 ⁶	800-1600	11000	4000	10	1.229	0.212	125	0.0085	0.009	W19
K2960TD520	N/A	5200	2960	32500	5.28 x 10 ⁶	800-1600	11000	4000	10	1.229	0.212	125	0.0085	0.009	W19
K2973FC600	N/A	6000	2973	35400	6.27 x 10 ⁶	1100-1500	6200	4000	10	1.581	0.207	115	0.0065	0.007	W15
K2973FC650	N/A	6500	2973	35400	6.27 x 10 ⁶	1100-1500	6200	4000	10	1.581	0.207	115	0.0065	0.007	W15
K2973FD600	N/A	6000	2973	35400	6.27 x 10 ⁶	1100-1500	6200	4000	10	1.581	0.207	115	TBC	TBC	W48
K2973FD650	N/A	6500	2973	35400	6.27 x 10 ⁶	1100-1500	6200	4000	10	1.581	0.207	115	TBC	TBC	W48
K3362TC360	N/A	3600	3362	39500	7.80 x 10 ⁶	1000-2000	7400	4000	10	1.052	0.168	125	0.0085	0.009	W14
K3362TC420	N/A	4200	3362	39500	7.80 x 10 ⁶	1000-2000	7400	4000	10	1.052	0.168	125	0.0085	0.009	W14
K3362TD360	N/A	3600	3362	39500	7.80 x 10 ⁶	1000-2000	7400	4000	10	1.052	0.168	125	0.0085	0.009	W19
K3362TD420	N/A	4200	3362	39500	7.80 x 10 ⁶	1000-2000	7400	4000	10	1.052	0.168	125	0.0085	0.009	W19
K3503FC450	N/A	4500	3503	43200	9.33 x 10 ⁶	900-1800	5500	4000	10	1.375	0.196	125	0.0065	0.007	W15
K3503FC520	N/A	5200	3503	43200	9.33 x 10 ⁶	900-1800	5500	4000	10	1.375	0.196	125	0.0065	0.007	W15
K3503FD450	N/A	4500	3503	43200	9.33 x 10 ⁶	900-1800	5500	4000	10	1.375	0.196	125	TBC	TBC	W48
K3503FD520	N/A	5200	3503	43200	9.33 x 10 ⁶	900-1800	5500	4000	10	1.375	0.196	125	TBC	TBC	W48
KX101FC360	N/A	3600										125	0.0065	0.007	W15
KX101FC420	N/A	4200										125	0.0065	0.007	W15
KX101FD360	N/A	3600										125	TBC	TBC	W48
KX101FD420	N/A	4200										125	TBC	TBC	W48

Product under development



Fig. W10
Weight 340 g



Fig. W11
Weight 510 g



Fig. W12
Weight 1000 g



Fig. W13
Weight 1700 g



Fig. W14
Weight 1300 g



Fig. W15
Weight 2800 g



Fig. W19
Weight 1700 g

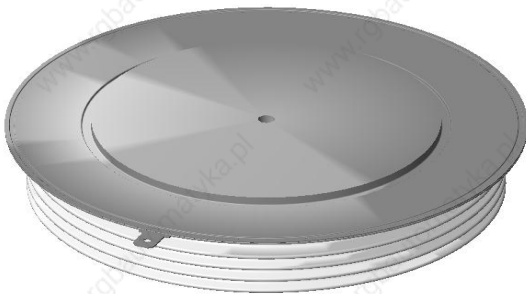

Fig. W46
Weight 1200 g

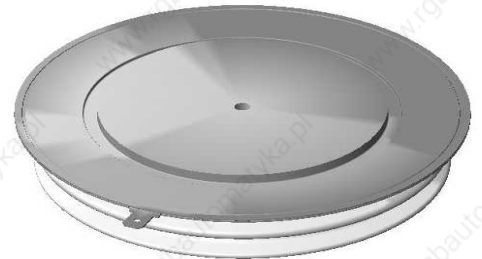

Fig. W50
Weight 750 g



Fig. W48
Weight 1200 g

We are widely acknowledged as the global leader in fast switching thyristor technologies.

Devices with blocking voltages up to 4.5kV and current ratings up to 4kA are available with turn off times as low as 10µs. Our patented distributed gate architecture together with highly efficient axial lifetime control produce a unique combination of high di/dt capability, fast / soft recovery and low conduction losses.

Fast Turn-Off and Distributed Gate Thyristor devices allow the development of highly efficient, compact and reliable high frequency resonant converters for demanding applications such as induction heating, traction and UPS.

Additionally these devices make an excellent choice for fast high-energy switches such as pulsed power and crowbars. As with all of our high power semiconductors, these parts utilise advanced compression bonded construction ensuring long term reliability in applications subject to repeated power cycles.

Fast Turn-Off Thyristors - Stud Types

Type		V _{DRM} / V _{RRM} V	I _{TAV} T _K = 55°C A	I _{TSM} 10ms ½ sine V _R ≤ 60% V _{RRM} A	I ² t V _R ≤ 60% V _{RRM} V _{RRM} A ² s	t _q @ 200V/µs µs	Typ. Reverse Recovery Charge			V _{TO} @T _J max V	r _T mΩ	T _J max °C	R _{thJC} d.c. 180° sine K/W	Fig. No
Part No.	Old Part No.						Q _r µC	@I _{TM} A	@-di/dt A/µs					
P0128SH10D	N/A	1000	128	1700	19 × 10 ³	20	25	100	10	1.600	2.490	125	0.23	W17
P0128SH10E	N/A	1000	128	1700	19 × 10 ³	25	25	100	10	1.600	2.490	125	0.23	W17
P0128SH10F	N/A	1000	128	1700	19 × 10 ³	30	25	100	10	1.600	2.490	125	0.23	W17
P0128SH12D	N/A	1200	128	1700	19 × 10 ³	20	25	100	10	1.600	2.490	125	0.23	W17
P0128SH12E	N/A	1200	128	1700	19 × 10 ³	25	25	100	10	1.600	2.490	125	0.23	W17
P0128SH12F	N/A	1200	128	1700	19 × 10 ³	30	25	100	10	1.600	2.490	125	0.23	W17
P0128SJ10D	N/A	1000	128	1700	19 × 10 ³	20	25	100	10	1.600	2.490	125	0.23	W16
P0128SJ10E	N/A	1000	128	1700	19 × 10 ³	25	25	100	10	1.600	2.490	125	0.23	W16
P0128SJ10F	N/A	1000	128	1700	19 × 10 ³	30	25	100	10	1.600	2.490	125	0.23	W16
P0128SJ12D	N/A	1200	128	1700	19 × 10 ³	20	25	100	10	1.600	2.490	125	0.23	W16
P0128SJ12E	N/A	1200	128	1700	19 × 10 ³	25	25	100	10	1.600	2.490	125	0.23	W16
P0128SJ12F	N/A	1200	128	1700	19 × 10 ³	30	25	100	10	1.600	2.490	125	0.23	W16
P0248SC10D	P200PH10	1000	248	2700	36.5 × 10 ³	20	25	300	20	1.600	1.230	125	0.12	W18
P0248SC10E	P200PH10	1000	248	2700	36.5 × 10 ³	25	25	300	20	1.600	1.230	125	0.12	W18
P0248SC10F	P200PH10	1000	248	2700	36.5 × 10 ³	30	25	300	20	1.600	1.230	125	0.12	W18
P0248SC12D	P200PH12	1200	248	2700	36.5 × 10 ³	20	25	300	20	1.600	1.230	125	0.12	W18
P0248SC12E	P200PH12	1200	248	2700	36.5 × 10 ³	25	25	300	20	1.600	1.230	125	0.12	W18
P0248SC12F	P200PH12	1200	248	2700	36.5 × 10 ³	30	25	300	20	1.600	1.230	125	0.12	W18
P0248SG10D	N/A	1000	248	2700	36.5 × 10 ³	20	25	300	20	1.600	1.230	125	0.12	W25
P0248SG10E	N/A	1000	248	2700	36.5 × 10 ³	25	25	300	20	1.600	1.230	125	0.12	W25
P0248SG10F	N/A	1000	248	2700	36.5 × 10 ³	30	25	300	20	1.600	1.230	125	0.12	W25
P0248SG12D	N/A	1200	248	2700	36.5 × 10 ³	20	25	300	20	1.600	1.230	125	0.12	W25
P0248SG12E	N/A	1200	248	2700	36.5 × 10 ³	25	25	300	20	1.600	1.230	125	0.12	W25
P0248SG12F	N/A	1200	248	2700	36.5 × 10 ³	30	25	300	20	1.600	1.230	125	0.12	W25
P0273SC10D	P202PH10	1000	273	3250	52.8 × 10 ³	20	45	300	20	1.550	0.870	125	0.12	W18
P0273SC10E	P202PH10	1000	273	3250	52.8 × 10 ³	25	45	300	20	1.550	0.870	125	0.12	W18
P0273SC10F	P202PH10	1000	273	3250	52.8 × 10 ³	30	45	300	20	1.550	0.870	125	0.12	W18
P0273SC12D	P202PH12	1200	273	3250	52.8 × 10 ³	20	45	300	20	1.550	0.870	125	0.12	W18
P0273SC12E	P202PH12	1200	273	3250	52.8 × 10 ³	25	45	300	20	1.550	0.870	125	0.12	W18
P0273SC12F	P202PH12	1200	273	3250	52.8 × 10 ³	30	45	300	20	1.550	0.870	125	0.12	W18
P0273SG10D	N/A	1000	273	3250	52.8 × 10 ³	20	45	300	20	1.550	0.870	125	0.12	W25
P0273SG10E	N/A	1000	273	3250	52.8 × 10 ³	25	45	300	20	1.550	0.870	125	0.12	W25
P0273SG10F	N/A	1000	273	3250	52.8 × 10 ³	30	45	300	20	1.550	0.870	125	0.12	W25
P0273SG12D	N/A	1200	273	3250	52.8 × 10 ³	20	45	300	20	1.550	0.870	125	0.12	W25
P0273SG12E	N/A	1200	273	3250	52.8 × 10 ³	25	45	300	20	1.550	0.870	125	0.12	W25
P0273SG12F	N/A	1200	273	3250	52.8 × 10 ³	30	45	300	20	1.550	0.870	125	0.12	W25
P0306SC04A	P214PH04	400	306	4700	101 × 10 ³	10	25	300	20	1.400	0.670	125	0.12	W18
P0306SC04B	P214PH04	400	306	4700	101 × 10 ³	12	25	300	20	1.400	0.670	125	0.12	W18
P0306SC04C	P214PH04	400	306	4700	101 × 10 ³	15	25	300	20	1.400	0.670	125	0.12	W18
P0306SC08A	P214PH08	800	306	4700	101 × 10 ³	10	25	300	20	1.400	0.670	125	0.12	W18
P0306SC08B	P214PH08	800	306	4700	101 × 10 ³	12	25	300	20	1.400	0.670	125	0.12	W18
P0306SC08C	P214PH08	800	306	4700	101 × 10 ³	15	25	300	20	1.400	0.670	125	0.12	W18
P0306SG04A	N/A	400	306	4700	101 × 10 ³	10	25	300	20	1.400	0.670	125	0.12	W25
P0306SG04B	N/A	400	306	4700	101 × 10 ³	12	25	300	20	1.400	0.670	125	0.12	W25
P0306SG04C	N/A	400	306	4700	101 × 10 ³	15	25	300	20	1.400	0.670	125	0.12	W25
P0306SG08A	N/A	800	306	4700	101 × 10 ³	10	25	300	20	1.400	0.670	125	0.12	W25
P0306SG08B	N/A	800	306	4700	101 × 10 ³	12	25	300	20	1.400	0.670	125	0.12	W25
P0306SG08C	N/A	800	306	4700	101 × 10 ³	15	25	300	20	1.400	0.670	125	0.12	W25

Fast Turn-Off Thyristors - Stud Types, continued

Type		V_{DRM} / V_{RRM}	I_{TAV} $T_K = 55^\circ C$	I_{TSM} 10ms 1/2 sine $V_R \leq 60\% V_{RRM}$	I^2t $V_R \leq 60\%$ V_{RRM} A^2s	t_q @ 200V/ μs	Typ. Reverse Recovery Charge			V_{TO} @ T_{Jmax}	r_T $m\Omega$	T_{Jmax} $^\circ C$	R_{thJC} d.c. 180° sine K/W	Fig. No.
Part No.	Old Part No.						V	A	Q_r μC					
P0311SC10E	P205PH10	1000	311	3600	64.8×10^3	25	30	300	20	1.170	0.920	125	0.12	W18
P0311SC10F	P205PH10	1000	311	3600	64.8×10^3	30	30	300	20	1.170	0.920	125	0.12	W18
P0311SC10G	P205PH10	1000	311	3600	64.8×10^3	35	30	300	20	1.170	0.920	125	0.12	W18
P0311SC12E	P205PH12	1200	311	3600	64.8×10^3	25	30	300	20	1.170	0.920	125	0.12	W18
P0311SC12F	P205PH12	1200	311	3600	64.8×10^3	30	30	300	20	1.170	0.920	125	0.12	W18
P0311SC12G	P205PH12	1200	311	3600	64.8×10^3	35	30	300	20	1.170	0.920	125	0.12	W18
P0311SG10E	N/A	1000	311	3600	64.8×10^3	25	30	300	20	1.170	0.920	125	0.12	W25
P0311SG10F	N/A	1000	311	3600	64.8×10^3	30	30	300	20	1.170	0.920	125	0.12	W25
P0311SG10G	N/A	1000	311	3600	64.8×10^3	35	30	300	20	1.170	0.920	125	0.12	W25
P0311SG12E	N/A	1200	311	3600	64.8×10^3	25	30	300	20	1.170	0.920	125	0.12	W25
P0311SG12F	N/A	1200	311	3600	64.8×10^3	30	30	300	20	1.170	0.920	125	0.12	W25
P0311SG12G	N/A	1200	311	3600	64.8×10^3	35	30	300	20	1.170	0.920	125	0.12	W25
P0330SC04C	P215PH04	400	330	5000	125×10^3	15	30	300	20	1.050	0.880	125	0.12	W18
P0330SC04D	P215PH04	400	330	5000	125×10^3	20	30	300	20	1.050	0.880	125	0.12	W18
P0330SC08C	P215PH08	800	330	5000	125×10^3	15	30	300	20	1.050	0.880	125	0.12	W18
P0330SC08D	P215PH08	800	330	5000	125×10^3	20	30	300	20	1.050	0.880	125	0.12	W18
P0330SG04C	N/A	400	330	5000	125×10^3	15	30	300	20	1.050	0.880	125	0.12	W25
P0330SG04D	N/A	400	330	5000	125×10^3	20	30	300	20	1.050	0.880	125	0.12	W25
P0330SG08C	N/A	800	330	5000	125×10^3	15	30	300	20	1.050	0.880	125	0.12	W25
P0330SG08D	N/A	800	330	5000	125×10^3	20	30	300	20	1.050	0.880	125	0.12	W25
P0431SC04B	P270PH04	400	431	6500	211×10^3	12	106	300	20	0.950	0.377	125	0.12	W18
P0431SC04C	P270PH04	400	431	6500	211×10^3	15	106	300	20	0.950	0.377	125	0.12	W18
P0431SC06B	P270PH06	600	431	6500	211×10^3	12	106	300	20	0.950	0.377	125	0.12	W18
P0431SC06C	P270PH06	600	431	6500	211×10^3	15	106	300	20	0.950	0.377	125	0.12	W18
P0431SG04B	N/A	400	431	6500	211×10^3	12	106	300	20	0.950	0.377	125	0.12	W25
P0431SG04C	N/A	400	431	6500	211×10^3	15	106	300	20	0.950	0.377	125	0.12	W25
P0431SG06B	N/A	600	431	6500	211×10^3	12	106	300	20	0.950	0.377	125	0.12	W25
P0431SG06C	N/A	600	431	6500	211×10^3	15	106	300	20	0.950	0.377	125	0.12	W25



Fig. W16
Weight 100 g

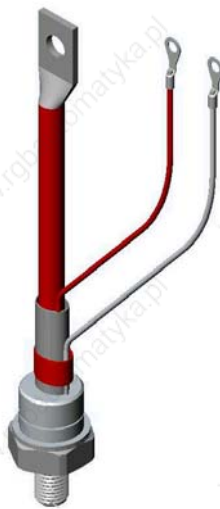

Fig. W17
Weight 130 g

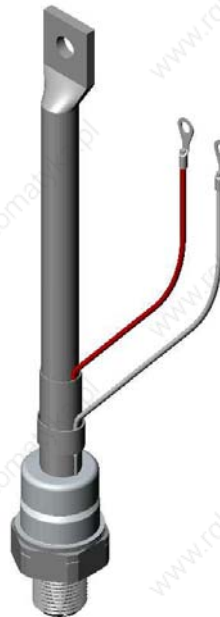

Fig. W18
Weight 250 g



Fig. W25
Weight 220g

Westcode "P" series of fast switching thyristors have regenerative gate structure to ensure low switching losses and high di/dt performance. "P" Series devices are particularly attractive to; Inverter, DC chopper

drives, UPS and Pulse Power applications. In addition to pressure contact technology these devices offer lower reverse recovery charge values, low forward switching losses and high reliability.

Fast Turn-Off Thyristors - Capsule Types

Type		V _{DRM} / V _{RRM}	I _{TAV} T _K = 55°C	I _{TSM} 10ms ½ sine V _R ≤ 60% V _{RRM}	I ² t V _R ≤ 60% V _{RRM} A ² s	t _q @ 200V/μs	Typ. Reverse Recovery Charge			V _{TO} @T _j max	r _T mΩ	T _j max °C	R _{thJK} d.c. 180° sine K/W	Fig. No.
Part No.	Old Part No.						V	A	A					
P0295WC12D	P200CH12	1200	295	2700	36.5 x 10 ³	20	25	300	20	1.600	1.230	125	0.095	W8
P0295WC12E	P200CH12	1200	295	2700	36.5 x 10 ³	25	25	300	20	1.600	1.230	125	0.095	W8
P0295WC12F	P200CH12	1200	295	2700	36.5 x 10 ³	30	25	300	20	1.600	1.230	125	0.095	W8
P0327WC12D	P202CH12	1200	327	3250	52.8 x 10 ³	20	45	300	20	1.550	0.870	125	0.095	W8
P0327WC12E	P202CH12	1200	327	3250	52.8 x 10 ³	25	45	300	20	1.550	0.870	125	0.095	W8
P0327WC12F	P202CH12	1200	327	3250	52.8 x 10 ³	30	45	300	20	1.550	0.870	125	0.095	W8
P0366WC04A	P214CH04	400	366	4700	110 x 10 ³	10	20	300	20	1.400	0.670	125	0.095	W8
P0366WC04B	P214CH04	400	366	4700	110 x 10 ³	12	20	300	20	1.400	0.670	125	0.095	W8
P0366WC04C	P214CH04	400	366	4700	110 x 10 ³	15	20	300	20	1.400	0.670	125	0.095	W8
P0366WC08A	P214CH08	800	366	4700	110 x 10 ³	10	20	300	20	1.400	0.670	125	0.095	W8
P0366WC08B	P214CH08	800	366	4700	110 x 10 ³	12	20	300	20	1.400	0.670	125	0.095	W8
P0366WC08C	P214CH08	800	366	4700	110 x 10 ³	15	20	300	20	1.400	0.670	125	0.095	W8
P0367WC12E	P205CH12	1200	367	3600	64.8 x 10 ³	25	45	300	20	1.170	0.920	125	0.095	W8
P0367WC12F	P205CH12	1200	367	3600	64.8 x 10 ³	30	45	300	20	1.170	0.920	125	0.095	W8
P0367WC12G	P205CH12	1200	367	3600	64.8 x 10 ³	35	45	300	20	1.170	0.920	125	0.095	W8
P0389WC04C	P215CH04	400	389	5000	125 x 10 ³	15	30	300	20	1.050	0.880	125	0.095	W8
P0389WC04D	P215CH04	400	389	5000	125 x 10 ³	20	30	300	20	1.050	0.880	125	0.095	W8
P0389WC08C	P215CH08	800	389	5000	125 x 10 ³	15	30	300	20	1.050	0.880	125	0.095	W8
P0389WC08D	P215CH08	800	389	5000	125 x 10 ³	20	30	300	20	1.050	0.880	125	0.095	W8
P0515WC04B	P270CH04	400	515	6500	211 x 10 ³	12	100	300	20	0.950	0.377	125	0.095	W8
P0515WC04C	P270CH04	400	515	6500	211 x 10 ³	15	100	300	20	0.950	0.377	125	0.095	W8
P0515WC04D	P270CH04	400	515	6500	211 x 10 ³	20	100	300	20	0.950	0.377	125	0.095	W8
P0515WC06B	P270CH06	600	515	6500	211 x 10 ³	12	100	300	20	0.950	0.377	125	0.095	W8
P0515WC06C	P270CH06	600	515	6500	211 x 10 ³	15	100	300	20	0.950	0.377	125	0.095	W8
P0515WC06D	P270CH06	600	515	6500	211 x 10 ³	20	100	300	20	0.950	0.377	125	0.095	W8
P0848YS04B	P280SH04	400	848	8750	383 x 10 ³	12	80	550	40	1.010	0.305	125	0.050	W9
P0848YS04C	P280SH04	400	848	8750	383 x 10 ³	15	80	550	40	1.010	0.305	125	0.050	W9
P0848YS04D	P280SH04	400	848	8750	383 x 10 ³	20	80	550	40	1.010	0.305	125	0.050	W9
P0848YS06B	P280SH06	600	848	8750	383 x 10 ³	12	80	550	40	1.010	0.305	125	0.050	W9
P0848YS06C	P280SH06	600	848	8750	383 x 10 ³	15	80	550	40	1.010	0.305	125	0.050	W9
P0848YS06D	P280SH06	600	848	8750	383 x 10 ³	20	80	550	40	1.010	0.305	125	0.050	W9
P1007LS12D	P300SH12	1200	1007	9500	451 x 10 ³	20	200	800	50	1.509	0.265	125	0.032	W10a
P1007LS12E	P300SH12	1200	1007	9500	451 x 10 ³	25	200	800	50	1.509	0.265	125	0.032	W10a
P1007LS12F	P300SH12	1200	1007	9500	451 x 10 ³	30	200	800	50	1.509	0.265	125	0.032	W10a



Fig. W8
Weight 70 g



Fig. W10a
Weight 340 g



Fig. W9
Weight 90 g

Recognised as the worldwide leader in distributed gate thyristor technology, these devices are available with blocking voltages to 5.2kV and currents to 3kA, with t_q from 10 to 300 μ s.

The unique distributed gate design and lifetime control features give these devices both high di/dt capability and fast low recovery turn-off, while maintaining a low forward voltage drop.

Ideally suited to applications including; induction heating, power supplies, high frequency inverters/converters, UPS and pulse power.

Distributed Gate Thyristors - Capsule Types

Type		V_{DRM} / V_{RRM}	I_{TAV} $T_K=$ 55°C	I_{TSM} 10ms 1/2 sine	I^2t $V_R \leq 60\%$	t_q @ 200V/ μ s	Typ. Reverse Recovery Charge $T_{j,max}$ 50% Chord			V_{TO}	r_T	$T_{j,max}$	R_{thJK} 180° Sine	Fig. No.
Part No.	Old Part No.	V	A	A	V_{RRM} A ² s	μ s	Q_{ra} μ C	@ I_{TM} A	@ -di/dt A/ μ s	@ $T_{j,max}$ V	m Ω	°C	K/W	
R0487YS10D	R210SH10	1000	487	4300	92.45×10^3	20	40	550	40	1.738	0.943	125	0.050	W9
R0487YS10E	R210SH10	1000	487	4300	92.45×10^3	25	40	550	40	1.738	0.943	125	0.050	W9
R0487YS10F	R210SH10	1000	487	4300	92.45×10^3	30	40	550	40	1.738	0.943	125	0.050	W9
R0487YS14D	R210SH14	1400	487	4300	92.45×10^3	20	40	550	40	1.738	0.943	125	0.050	W9
R0487YS14E	R210SH14	1400	487	4300	92.45×10^3	25	40	550	40	1.738	0.943	125	0.050	W9
R0487YS14F	R210SH14	1400	487	4300	92.45×10^3	30	40	550	40	1.738	0.943	125	0.050	W9
R0577YS08C	R185SH08	800	577	6000	180×10^3	15	85	550	40	1.510	0.640	125	0.050	W9
R0577YS08D	R185SH08	800	577	6000	180×10^3	20	85	550	40	1.510	0.640	125	0.050	W9
R0577YS08E	R185SH08	800	577	6000	180×10^3	25	85	550	40	1.510	0.640	125	0.050	W9
R0577YS12C	R185SH12	1200	577	6000	180×10^3	15	85	550	40	1.510	0.640	125	0.050	W9
R0577YS12D	R185SH12	1200	577	6000	180×10^3	20	85	550	40	1.510	0.640	125	0.050	W9
R0577YS12E	R185SH12	1200	577	6000	180×10^3	25	85	550	40	1.510	0.640	125	0.050	W9
R0633YS08D	R216SH08	800	633	6300	199×10^3	20	85	125	40	1.250	0.614	125	0.050	W9
R0633YS08E	R216SH08	800	633	6300	199×10^3	25	85	125	40	1.250	0.614	125	0.050	W9
R0633YS08F	R216SH08	800	633	6300	199×10^3	30	85	125	40	1.250	0.614	125	0.050	W9
R0633YS12D	R216SH12	1200	633	6300	199×10^3	20	85	125	40	1.250	0.612	125	0.050	W9
R0633YS12E	R216SH12	1200	633	6300	199×10^3	25	85	125	40	1.250	0.614	125	0.050	W9
R0633YS12F	R216SH12	1200	633	6300	199×10^3	30	85	125	40	1.250	0.614	125	0.050	W9
R0717LS14G	R181SH06	1400	717	7050	249×10^3	35	150	1000	60	1.752	0.732	125	0.032	W10a
R0717LS14H	R181SH06	1400	717	7050	249×10^3	40	150	1000	60	1.752	0.732	125	0.032	W10a
R0717LS14J	R181SH06	1400	717	7050	249×10^3	50	150	1000	60	1.752	0.732	125	0.032	W10a
R0717LS16G	R181SH10	1600	717	7050	249×10^3	35	150	1000	60	1.752	0.732	125	0.032	W10a
R0717LS16H	R181SH10	1600	717	7050	249×10^3	40	150	1000	60	1.752	0.732	125	0.032	W10a
R0717LS16J	R181SH10	1600	717	7050	249×10^3	50	150	1000	60	1.752	0.732	125	0.032	W10a
R0736LS20J	R175SH20	2000	736	6800	231×10^3	50	240	1000	60	1.842	0.619	125	0.032	W10a
R0736LS20K	R175SH20	2000	736	6800	231×10^3	60	240	1000	60	1.842	0.619	125	0.032	W10a
R0736LS20L	R175SH20	2000	736	6800	231×10^3	65	240	1000	60	1.842	0.619	125	0.032	W10a
R0736LS20M	R175SH20	2000	736	6800	231×10^3	70	240	1000	60	1.842	0.619	125	0.032	W10a
R0736LS25J	R175SH25	2500	736	6800	231×10^3	50	240	1000	60	1.842	0.619	125	0.032	W10a
R0736LS25K	R175SH25	2500	736	6800	231×10^3	60	240	1000	60	1.842	0.619	125	0.032	W10a
R0736LS25L	R175SH25	2500	736	6800	231×10^3	65	240	1000	60	1.842	0.619	125	0.032	W10a
R0736LS25M	R175SH25	2500	736	6800	231×10^3	70	240	1000	60	1.842	0.619	125	0.032	W10a
R0809LS06A	R180SH06	600	809	8000	320×10^3	10	50	1000	60	2.100	0.300	125	0.032	W10a
R0809LS06B	R180SH06	600	809	8000	320×10^3	12	50	1000	60	2.100	0.300	125	0.032	W10a
R0809LS06C	R180SH06	600	809	8000	320×10^3	15	50	1000	60	2.100	0.300	125	0.032	W10a
R0809LS10A	R180SH10	1000	809	8000	320×10^3	10	50	1000	60	2.100	0.300	125	0.032	W10a
R0809LS10B	R180SH10	1000	809	8000	320×10^3	12	50	1000	60	2.100	0.300	125	0.032	W10a
R0809LS10C	R180SH10	1000	809	8000	320×10^3	15	50	1000	60	2.100	0.300	125	0.032	W10a
R0830LS10D	R190SH10	1000	830	8500	361×10^3	20	110	1000	60	1.900	0.357	125	0.032	W10a
R0830LS10E	R190SH10	1000	830	8500	361×10^3	25	110	1000	60	1.900	0.357	125	0.032	W10a
R0830LS10F	R190SH10	1000	830	8500	361×10^3	30	110	1000	60	1.900	0.357	125	0.032	W10a
R0830LS10G	R190SH10	1000	830	8500	361×10^3	35	110	1000	60	1.900	0.357	125	0.032	W10a
R0830LS14D	R190SH14	1400	830	8500	361×10^3	20	110	1000	60	1.900	0.357	125	0.032	W10a
R0830LS14E	R190SH14	1400	830	8500	361×10^3	25	110	1000	60	1.900	0.357	125	0.032	W10a
R0830LS14F	R190SH14	1400	830	8500	361×10^3	30	110	1000	60	1.900	0.357	125	0.032	W10a
R0830LS14G	R190SH14	1400	830	8500	361×10^3	35	110	1000	60	1.900	0.357	125	0.032	W10a
R0878LS14K	R200SH16	1600	878	7500	281×10^3	60	350	1000	60	1.447	0.480	125	0.032	W10a
R0878LS14M	R200SH16	1600	878	7500	281×10^3	70	350	1000	60	1.447	0.480	125	0.032	W10a
R0878LS18K	R200SH18	1800	878	7500	281×10^3	60	350	1000	60	1.447	0.480	125	0.032	W10a
R0878LS18M	R200SH18	1800	878	7500	281×10^3	70	350	1000	60	1.447	0.480	125	0.032	W10a
R0878LS21K	R200SH21	2100	878	7500	281×10^3	60	350	1000	60	1.447	0.480	125	0.032	W10a
R0878LS21M	R200SH21	2100	878	7500	281×10^3	70	350	1000	60	1.447	0.480	125	0.032	W10a

Distributed Gate Thyristors - Capsule Types, continued

Type		V_{DRM} / V_{RRM}	I_{TAV} $T_K=55^\circ C$	I_{TSM} 10ms ½ sine $V_R \leq 60\% V_{RRM}$	I^2t $V_R \leq 60\%$ V_{RRM} A ² s	t_q @ 200V/ μs	Typ. Reverse Recovery Charge			V_{TO}	r_T	T_{jmax}	R_{thJK} 180° Sine K/W	Fig. No.
Part No.	Old Part No.						V	A	A					
R0929LS08C	R219SH08	800	929	9000	405×10^3	15	85	1000	60	1.549	0.350	125	0.032	W10a
R0929LS08D	R219SH08	800	929	9000	405×10^3	20	85	1000	60	1.549	0.350	125	0.032	W10a
R0929LS08E	R219SH08	800	929	9000	405×10^3	25	85	1000	60	1.549	0.350	125	0.032	W10a
R0929LS12C	R219SH12	1200	929	9000	405×10^3	15	85	1000	60	1.549	0.350	125	0.032	W10a
R0929LS12D	R219SH12	1200	929	9000	405×10^3	20	85	1000	60	1.549	0.350	125	0.032	W10a
R0929LS12E	R219SH12	1200	929	9000	405×10^3	25	85	1000	60	1.549	0.350	125	0.032	W10a
R0964LS08D	R220SH08	800	964	9400	442×10^3	20	75	1000	60	1.530	0.309	125	0.032	W10a
R0964LS08E	R220SH08	800	964	9400	442×10^3	25	75	1000	60	1.530	0.309	125	0.032	W10a
R0964LS08F	R220SH08	800	964	9400	442×10^3	30	75	1000	60	1.530	0.309	125	0.032	W10a
R0964LS12D	R220SH12	1200	964	9400	442×10^3	20	75	1000	60	1.530	0.309	125	0.032	W10a
R0964LS12E	R220SH12	1200	964	9400	442×10^3	25	75	1000	60	1.530	0.309	125	0.032	W10a
R0964LS12F	R220SH12	1200	964	9400	442×10^3	30	75	1000	60	1.530	0.309	125	0.032	W10a
R0990LS04A	R270SH08	800	990	11000	605×10^3	10	40	1000	60	1.350	0.350	125	0.032	W10a
R0990LS04B	R270SH08	800	990	11000	605×10^3	12	40	1000	60	1.350	0.350	125	0.032	W10a
R0990LS04C	R270SH08	800	990	11000	605×10^3	15	40	1000	60	1.350	0.350	125	0.032	W10a
R0990LS08A	R270SH12	1200	990	11000	605×10^3	10	40	1000	60	1.350	0.350	125	0.032	W10a
R0990LS08B	R270SH12	1200	990	11000	605×10^3	12	40	1000	60	1.350	0.350	125	0.032	W10a
R0990LS08C	R270SH12	1200	990	11000	605×10^3	15	40	1000	60	1.350	0.350	125	0.032	W10a
R1124NS14K	R305SH14	1400	1124	13500	911×10^3	60	400	1000	60	1.540	0.379	125	0.024	W11a
R1124NS14M	R305SH14	1400	1124	13500	911×10^3	70	400	1000	60	1.540	0.379	125	0.024	W11a
R1124NS18K	R305SH18	1800	1124	13500	911×10^3	60	400	1000	60	1.540	0.379	125	0.024	W11a
R1124NS18M	R305SH18	1800	1124	13500	911×10^3	70	400	1000	60	1.540	0.379	125	0.024	W11a
R1124NS21K	R305SH21	2100†	1124	13500	911×10^3	60	400	1000	60	1.540	0.379	125	0.024	W11a
R1124NS21M	R305SH21	2100†	1124	13500	911×10^3	70	400	1000	60	1.540	0.379	125	0.024	W11a
R1127NC32R	D315CH32	3200	1127	12800	819×10^3	140	1500	1000	60	1.500	0.474	125	0.022	W11
R1127NC32S	D315CH32	3200	1127	12800	819×10^3	160	1500	1000	60	1.500	0.474	125	0.022	W11
R1127NC32T	D315CH32	3200	1127	12800	819×10^3	200	1500	1000	60	1.500	0.474	125	0.022	W11
R1127NC36R	D315CH36	3600	1127	12800	819×10^3	140	1500	1000	60	1.500	0.474	125	0.022	W11
R1127NC36S	D315CH36	3600	1127	12800	819×10^3	160	1500	1000	60	1.500	0.474	125	0.022	W11
R1127NC36T	D315CH36	3600	1127	12800	819×10^3	200	1500	1000	60	1.500	0.474	125	0.022	W11
R1158NS24N	D350SH24	2400	1158	14500	1.05×10^6	100	900	1000	60	1.600	0.400	125	0.022	W11a
R1158NS24P	D350SH24	2400	1158	14500	1.05×10^6	120	900	1000	60	1.600	0.400	125	0.022	W11a
R1158NS26N	D350SH26	2600	1158	14500	1.05×10^6	100	900	1000	60	1.600	0.400	125	0.022	W11a
R1158NS26P	D350SH26	2600	1158	14500	1.05×10^6	120	900	1000	60	1.600	0.400	125	0.022	W11a
R1178NS10E	R325SH10	1000	1178	17000	1.45×10^6	25	170	1000	60	1.600	0.300	125	0.024	W11a
R1178NS10F	R325SH10	1000	1178	17000	1.45×10^6	30	170	1000	60	1.600	0.300	125	0.024	W11a
R1178NS10G	R325SH10	1000	1178	17000	1.45×10^6	35	170	1000	60	1.600	0.300	125	0.024	W11a
R1178NS14E	R325SH14	1400	1178	17000	1.45×10^6	25	170	1000	60	1.600	0.300	125	0.024	W11a
R1178NS14F	R325SH14	1400	1178	17000	1.45×10^6	30	170	1000	60	1.600	0.300	125	0.024	W11a
R1178NS14G	R325SH14	1400	1178	17000	1.45×10^6	35	170	1000	60	1.600	0.300	125	0.024	W11a
R1211NS08D	R350SH08	800	1211	17600	1.55×10^6	20	100	1000	60	1.720	0.230	125	0.024	W11a
R1211NS08E	R350SH08	800	1211	17600	1.55×10^6	25	100	1000	60	1.720	0.230	125	0.024	W11a
R1211NS12D	R350SH12	1200	1211	17600	1.55×10^6	20	100	1000	60	1.720	0.230	125	0.024	W11a
R1211NS12E	R350SH12	1200	1211	17600	1.55×10^6	25	100	1000	60	1.720	0.230	125	0.024	W11a
R1271NS08D	R355SH08	800	1271	18000	1.62×10^6	20	120	1000	60	1.550	0.236	125	0.024	W11a
R1271NS08E	R355SH08	800	1271	18000	1.62×10^6	25	120	1000	60	1.550	0.236	125	0.024	W11a
R1271NS08G	R355SH08	800	1271	18000	1.62×10^6	35	120	1000	60	1.550	0.236	125	0.024	W11a
R1271NS12D	R355SH12	1200	1271	18000	1.62×10^6	20	120	1000	60	1.550	0.236	125	0.024	W11a
R1271NS12E	R355SH12	1200	1271	18000	1.62×10^6	25	120	1000	60	1.550	0.236	125	0.024	W11a
R1271NS12G	R355SH12	1200	1271	18000	1.62×10^6	35	120	1000	60	1.550	0.236	125	0.024	W11a
R1275NS14L	R395SH14	1400	1275	15500	1.20×10^6	65	420	1000	60	1.207	0.342	125	0.024	W11a
R1275NS14M	R395SH14	1400	1275	15500	1.20×10^6	70	420	1000	60	1.207	0.342	125	0.024	W11a
R1275NS18L	R395SH18	1800	1275	15500	1.20×10^6	65	420	1000	60	1.207	0.342	125	0.024	W11a
R1275NS18M	R395SH18	1800	1275	15500	1.20×10^6	70	420	1000	60	1.207	0.342	125	0.024	W11a
R1275NS21L	R395SH21	2100†	1275	15500	1.20×10^6	65	420	1000	60	1.207	0.342	125	0.024	W11a
R1275NS21M	R395SH21	2100†	1275	15500	1.20×10^6	70	420	1000	60	1.207	0.342	125	0.024	W11a

Distributed Gate Thyristors - Capsule Types, continued

Type		V_{DRM} / V_{RRM}	I_{TAV} $T_K=55^\circ C$	I_{TSM} 10ms 1/2 sine $V_R \leq 60\% V_{RRM}$	I^2t $V_R \leq 60\%$ V_{RRM} A^2s	t_q @ 200V/ μs	Typ. Reverse Recovery Charge			V_{TO}	r_T	T_{jmax}	R_{thJK} 180° Sine K/W	Fig. No.
Part No.	Old Part No.						V	A	A					
R1279NS22J	D391SH22	2200	1279	14800	1.10×10^6	50	700	1000	60	1.440	0.330	125	0.022	W11a
R1279NS22K	D391SH22	2200	1279	14800	1.10×10^6	60	700	1000	60	1.440	0.330	125	0.022	W11a
R1279NS22M	D391SH22	2200	1279	14800	1.10×10^6	70	700	1000	60	1.440	0.330	125	0.022	W11a
R1279NS25J	D391SH25	2500	1279	14800	1.10×10^6	50	700	1000	60	1.440	0.330	125	0.022	W11a
R1279NS25K	D391SH25	2500	1279	14800	1.10×10^6	60	700	1000	60	1.440	0.330	125	0.022	W11a
R1279NS25M	D391SH25	2500	1279	14800	1.10×10^6	70	700	1000	60	1.440	0.330	125	0.022	W11a
R1280NS18J	D390SH18	1800	1280	14800	1.10×10^6	50	600	1000	60	1.440	0.330	125	0.022	W11a
R1280NS18K	D390SH18	1800	1280	14800	1.10×10^6	60	600	1000	60	1.440	0.330	125	0.022	W11a
R1280NS18M	D390SH18	1800	1280	14800	1.10×10^6	70	600	1000	60	1.440	0.330	125	0.022	W11a
R1280NS21J	D390SH21	2100	1280	14800	1.10×10^6	50	600	1000	60	1.440	0.330	125	0.022	W11a
R1280NS21K	D390SH21	2100	1280	14800	1.10×10^6	60	600	1000	60	1.440	0.330	125	0.022	W11a
R1280NS21M	D390SH21	2100	1280	14800	1.10×10^6	70	600	1000	60	1.440	0.330	125	0.022	W11a
R1280NS25J	D390SH25	2500	1280	14800	1.10×10^6	50	600	1000	60	1.440	0.330	125	0.022	W11a
R1280NS25K	D390SH25	2500	1280	14800	1.10×10^6	60	600	1000	60	1.440	0.330	125	0.022	W11a
R1280NS25M	D390SH25	2500	1280	14800	1.10×10^6	70	600	1000	60	1.440	0.330	125	0.022	W11a
R1331NS10B	D450SH10	1000	1331	18200	1.66×10^6	12	80	1000	60	1.450	0.285	125	0.022	W11a
R1331NS10C	D450SH10	1000	1331	18200	1.66×10^6	15	80	1000	60	1.450	0.285	125	0.022	W11a
R1331NS10D	D450SH10	1000	1331	18200	1.66×10^6	20	80	1000	60	1.450	0.285	125	0.022	W11a
R1331NS12B	D450SH12	1200	1331	18200	1.66×10^6	12	80	1000	60	1.450	0.285	125	0.022	W11a
R1331NS12C	D450SH12	1200	1331	18200	1.66×10^6	15	80	1000	60	1.450	0.285	125	0.022	W11a
R1331NS12D	D450SH12	1200	1331	18200	1.66×10^6	20	80	1000	60	1.450	0.285	125	0.022	W11a
R1446NS08E	R400SH08	800	1446	19500	1.90×10^6	25	120	1000	60	1.304	0.200	125	0.024	W11a
R1446NS08F	R400SH08	800	1446	19500	1.90×10^6	30	120	1000	60	1.304	0.200	125	0.024	W11a
R1446NS08G	R400SH08	800	1446	19500	1.90×10^6	35	120	1000	60	1.304	0.200	125	0.024	W11a
R1446NS12E	R400SH12	1200	1446	19500	1.90×10^6	25	120	1000	60	1.304	0.200	125	0.024	W11a
R1446NS12F	R400SH12	1200	1446	19500	1.90×10^6	30	120	1000	60	1.304	0.200	125	0.024	W11a
R1446NS12G	R400SH12	1200	1446	19500	1.90×10^6	35	120	1000	60	1.304	0.200	125	0.024	W11a
R1448NS14H	D405SH14	1400	1448	15500	1.20×10^6	40	500	1000	60	1.350	0.250	125	0.022	W11a
R1448NS14J	D405SH14	1400	1448	15500	1.20×10^6	50	500	1000	60	1.350	0.250	125	0.022	W11a
R1448NS14L	D405SH14	1400	1448	15500	1.20×10^6	65	500	1000	60	1.350	0.250	125	0.022	W11a
R1448NS18H	D405SH18	1800	1448	15500	1.20×10^6	40	500	1000	60	1.350	0.250	125	0.022	W11a
R1448NS18J	D405SH18	1800	1448	15500	1.20×10^6	50	500	1000	60	1.350	0.250	125	0.022	W11a
R1448NS18L	D405SH18	1800	1448	15500	1.20×10^6	65	500	1000	60	1.350	0.250	125	0.022	W11a
R1448NS20H	N/A	2000	1448	15500	1.20×10^6	40	500	1000	60	1.350	0.250	125	0.022	W11a
R1448NS20J	N/A	2000	1448	15500	1.20×10^6	50	500	1000	60	1.350	0.250	125	0.022	W11a
R1448NS20L	N/A	2000	1448	15500	1.20×10^6	65	500	1000	60	1.350	0.250	125	0.022	W11a
R2475ZC20N	R500CH20	2000	2475	31000	4.81×10^6	100	1700	4000	60	1.504	0.174	125	0.011	W13
R2475ZC28N	R500CH28	2800	2475	31000	4.81×10^6	100	1700	4000	60	1.504	0.174	125	0.011	W13
R2475ZD20N	R500DH20	2000	2475	31000	4.81×10^6	100	1700	4000	60	1.504	0.174	125	0.011	W46
R2475ZD28N	R500DH28	2800	2475	31000	4.81×10^6	100	1700	4000	60	1.504	0.174	125	0.011	W46
R2619ZC18J	R600CH18	1800	2619	33800	5.71×10^6	50	1100	4000	60	1.308	0.173	125	0.011	W13
R2619ZC18K	R600CH18	1800	2619	33800	5.71×10^6	60	1100	4000	60	1.308	0.173	125	0.011	W13
R2619ZC18L	R600CH18	1800	2619	33800	5.71×10^6	65	1100	4000	60	1.308	0.173	125	0.011	W13
R2619ZC21J	R600CH21	2100†	2619	33800	5.71×10^6	50	1100	4000	60	1.308	0.173	125	0.011	W13
R2619ZC21K	R600CH21	2100†	2619	33800	5.71×10^6	60	1100	4000	60	1.308	0.173	125	0.011	W13
R2619ZC21L	R600CH21	2100†	2619	33800	5.71×10^6	65	1100	4000	60	1.308	0.173	125	0.011	W13
R2619ZC25J	R600CH25	2500†	2619	33800	5.71×10^6	50	1100	4000	60	1.308	0.173	125	0.011	W13
R2619ZC25K	R600CH25	2500†	2619	33800	5.71×10^6	60	1100	4000	60	1.308	0.173	125	0.011	W13
R2619ZC25L	R600CH25	2500†	2619	33800	5.71×10^6	65	1100	4000	60	1.308	0.173	125	0.011	W13
R2619ZD18J	N/A	1800	2619	33800	5.71×10^6	50	1100	4000	60	1.308	0.173	125	0.011	W46
R2619ZD18K	N/A	1800	2619	33800	5.71×10^6	60	1100	4000	60	1.308	0.173	125	0.011	W46
R2619ZD18L	N/A	1800	2619	33800	5.71×10^6	65	1100	4000	60	1.308	0.173	125	0.011	W46
R2619ZD21J	N/A	2100†	2619	33800	5.71×10^6	50	1100	4000	60	1.308	0.173	125	0.011	W46
R2619ZD21K	N/A	2100†	2619	33800	5.71×10^6	60	1100	4000	60	1.308	0.173	125	0.011	W46
R2619ZD21L	N/A	2100†	2619	33800	5.71×10^6	65	1100	4000	60	1.308	0.173	125	0.011	W46
R2619ZD25J	N/A	2500†	2619	33800	5.71×10^6	50	1100	4000	60	1.308	0.173	125	0.011	W46
R2619ZD25K	N/A	2500†	2619	33800	5.71×10^6	60	1100	4000	60	1.308	0.173	125	0.011	W46
R2619ZD25L	N/A	2500†	2619	33800	5.71×10^6	65	1100	4000	60	1.308	0.173	125	0.011	W46

NB: † - V_{RM} 1800V max

Distributed Gate Thyristors - Capsule Types, continued

Type		V_{DRM} / V_{RRM}	I_{TAV} $T_K=55^\circ C$	I_{TSM} 10ms ½ sine $V_R \leq 60\% V_{RRM}$	I^2t $V_R \leq 60\%$ V_{RRM} A^2s	t_q @ 200V/ μs	Typ. Reverse Recovery Charge T_{jmax} 50% Chord			V_{TO}	r_T	T_{jmax}	R_{thJK} 180° Sine K/W	Fig. No.
Part No.	Old Part No.	V	A	A		μs	Q_{rr} μC	@ I_{TM} A	@ $-di/dt$ A/ μs	@ T_{jmax} V	m Ω	°C		
R2620ZC22J	R610CH22	2200	2620	33800	5.71×10^6	50	1200	4000	60	1.500	0.143	125	0.011	W13
R2620ZC22K	R610CH22	2200	2620	33800	5.71×10^6	60	1200	4000	60	1.500	0.143	125	0.011	W13
R2620ZC22L	R610CH22	2200	2620	33800	5.71×10^6	65	1200	4000	60	1.500	0.143	125	0.011	W13
R2620ZC25J	R610CH25	2500	2620	33800	5.71×10^6	50	1200	4000	60	1.500	0.143	125	0.011	W13
R2620ZC25K	R610CH25	2500	2620	33800	5.71×10^6	60	1200	4000	60	1.500	0.143	125	0.011	W13
R2620ZC25L	R610CH25	2500	2620	33800	5.71×10^6	65	1200	4000	60	1.500	0.143	125	0.011	W13
R2620ZD22J	N/A	2200	2620	33800	5.71×10^6	50	1200	4000	60	1.500	0.143	125	0.011	W46
R2620ZD22K	N/A	2200	2620	33800	5.71×10^6	60	1200	4000	60	1.500	0.143	125	0.011	W46
R2620ZD22L	N/A	2200	2620	33800	5.71×10^6	65	1200	4000	60	1.500	0.143	125	0.011	W46
R2620ZD25J	N/A	2500	2620	33800	5.71×10^6	50	1200	4000	60	1.500	0.143	125	0.011	W46
R2620ZD25K	N/A	2500	2620	33800	5.71×10^6	60	1200	4000	60	1.500	0.143	125	0.011	W46
R2620ZD25L	N/A	2500	2620	33800	5.71×10^6	65	1200	4000	60	1.500	0.143	125	0.011	W46
R2714ZC16H	R800CH16	1600	2714	35600	6.34×10^6	40	700	4000	60	1.250	0.163	125	0.011	W13
R2714ZC16J	R800CH16	1600	2714	35600	6.34×10^6	50	700	4000	60	1.250	0.163	125	0.011	W13
R2714ZC16K	R800CH16	1600	2714	35600	6.34×10^6	60	700	4000	60	1.250	0.163	125	0.011	W13
R2714ZC18H	R800CH18	1800	2714	35600	6.34×10^6	40	700	4000	60	1.250	0.163	125	0.011	W13
R2714ZC18J	R800CH18	1800	2714	35600	6.34×10^6	50	700	4000	60	1.250	0.163	125	0.011	W13
R2714ZC18K	R800CH18	1800	2714	35600	6.34×10^6	60	700	4000	60	1.250	0.163	125	0.011	W13
R2714ZD16H	N/A	1600	2714	35600	6.34×10^6	40	700	4000	60	1.250	0.163	125	0.011	W46
R2714ZD16J	N/A	1600	2714	35600	6.34×10^6	50	700	4000	60	1.250	0.163	125	0.011	W46
R2714ZD16K	N/A	1600	2714	35600	6.34×10^6	60	700	4000	60	1.250	0.163	125	0.011	W46
R2714ZD18H	N/A	1800	2714	35600	6.34×10^6	40	700	4000	60	1.250	0.163	125	0.011	W46
R2714ZD18J	N/A	1800	2714	35600	6.34×10^6	50	700	4000	60	1.250	0.163	125	0.011	W46
R2714ZD18K	N/A	1800	2714	35600	6.34×10^6	60	700	4000	60	1.250	0.163	125	0.011	W46
R3047TC24N	R1863CH24	2400	3047	50000	12.5×10^6	100	1400	4000	60	1.580	0.170	125	0.008	W14
R3047TC24R	R1863CH24	2400	3047	50000	12.5×10^6	140	1400	4000	60	1.580	0.170	125	0.008	W14
R3047TC24T	R1863CH24	2400	3047	50000	12.5×10^6	200	1400	4000	60	1.580	0.170	125	0.008	W14
R3047TC28N	R1863CH28	2800	3047	50000	12.5×10^6	100	1400	4000	60	1.580	0.170	125	0.008	W14
R3047TC28R	R1863CH28	2800	3047	50000	12.5×10^6	140	1400	4000	60	1.580	0.170	125	0.008	W14
R3047TC28T	R1863CH28	2800	3047	50000	12.5×10^6	200	1400	4000	60	1.580	0.170	125	0.008	W14
R3047TD24N	R1863DH24	2400	3047	50000	12.5×10^6	100	1400	4000	60	1.580	0.170	125	0.008	W19
R3047TD24R	R1863DH24	2400	3047	50000	12.5×10^6	140	1400	4000	60	1.580	0.170	125	0.008	W19
R3047TD24T	R1863DH24	2400	3047	50000	12.5×10^6	200	1400	4000	60	1.580	0.170	125	0.008	W19
R3047TD28N	R1863DH28	2800	3047	50000	12.5×10^6	100	1400	4000	60	1.580	0.170	125	0.008	W19
R3047TD28R	R1863DH28	2800	3047	50000	12.5×10^6	140	1400	4000	60	1.580	0.170	125	0.008	W19
R3047TD28T	R1863DH28	2800	3047	50000	12.5×10^6	200	1400	4000	60	1.580	0.170	125	0.008	W19
R3370ZC10C	R1200CH10	1000	3370	43900	9.64×10^6	15	240	4000	60	1.353	0.064	125	0.011	W13
R3370ZC10D	R1200CH10	1000	3370	43900	9.64×10^6	20	240	4000	60	1.353	0.064	125	0.011	W13
R3370ZC10E	R1200CH10	1000	3370	43900	9.64×10^6	25	240	4000	60	1.353	0.064	125	0.011	W13
R3370ZC12C	R1200CH12	1200	3370	43900	9.64×10^6	15	240	4000	60	1.353	0.064	125	0.011	W13
R3370ZC12D	R1200CH12	1200	3370	43900	9.64×10^6	20	240	4000	60	1.353	0.064	125	0.011	W13
R3370ZC12E	R1200CH12	1200	3370	43900	9.64×10^6	25	240	4000	60	1.353	0.064	125	0.011	W13
R3370ZD10C	N/A	1000	3370	43900	9.64×10^6	15	240	4000	60	1.353	0.064	125	0.011	W46
R3370ZD10D	N/A	1000	3370	43900	9.64×10^6	20	240	4000	60	1.353	0.064	125	0.011	W46
R3370ZD10E	N/A	1000	3370	43900	9.64×10^6	25	240	4000	60	1.353	0.064	125	0.011	W46
R3370ZD12C	N/A	1200	3370	43900	9.64×10^6	15	240	4000	60	1.353	0.064	125	0.011	W46
R3370ZD12D	N/A	1200	3370	43900	9.64×10^6	20	240	4000	60	1.353	0.064	125	0.011	W46
R3370ZD12E	N/A	1200	3370	43900	9.64×10^6	25	240	4000	60	1.353	0.064	125	0.011	W46
R3559TC16K	R1966CH16	1600	3559	38900	7.57×10^6	60	750	4000	60	1.173	0.155	125	0.008	W14
R3559TC16N	R1966CH16	1600	3559	38900	7.57×10^6	100	750	4000	60	1.173	0.155	125	0.008	W14
R3559TC16R	R1966CH16	1600	3559	38900	7.57×10^6	140	750	4000	60	1.173	0.155	125	0.008	W14
R3559TC16T	R1966CH16	1600	3559	38900	7.57×10^6	200	750	4000	60	1.173	0.155	125	0.008	W14
R3559TC20K	R1966CH20	2000	3559	38900	7.57×10^6	60	750	4000	60	1.173	0.155	125	0.008	W14
R3559TC20N	R1966CH20	2000	3559	38900	7.57×10^6	100	750	4000	60	1.173	0.155	125	0.008	W14
R3559TC20R	R1966CH20	2000	3559	38900	7.57×10^6	140	750	4000	60	1.173	0.155	125	0.008	W14
R3559TC20T	R1966CH20	2000	3559	38900	7.57×10^6	200	750	4000	60	1.173	0.155	125	0.008	W14

Distributed Gate Thyristors - Capsule Types, Packages

Type		V_{DRM} / V_{RRM}	I_{TAV} $T_K=55^\circ C$	I_{TSM} 10ms 1/2 sine $V_R \leq 60\% V_{RRM}$	I^2t $V_R \leq 60\%$ V_{RRM} A^2s	t_q @ 200V/ μs	Typ. Reverse Recovery Charge T_{jmax} 50% Chord			V_{T0}	r_T	T_{jmax}	R_{thJK} 180° Sine K/W	Fig. No.
Part No.	Old Part No	V	A	A	A^2s	μs	Q_{ra} μC	@ I_{TM} A	@ -di/dt A/ μs	V	m Ω	°C		
R3559TD16K	R1966DH16	1600	3559	38900	7.57×10^6	60	750	4000	60	1.173	0.155	125	0.008	W19
R3559TD16N	R1966DH16	1600	3559	38900	7.57×10^6	100	750	4000	60	1.173	0.155	125	0.008	W19
R3559TD16R	R1966DH16	1600	3559	38900	7.57×10^6	140	750	4000	60	1.173	0.155	125	0.008	W19
R3559TD16T	R1966DH16	1600	3559	38900	7.57×10^6	200	750	4000	60	1.173	0.155	125	0.008	W19
R3559TD20K	R1966DH20	2000	3559	38900	7.57×10^6	60	750	4000	60	1.173	0.155	125	0.008	W19
R3559TD20N	R1966DH20	2000	3559	38900	7.57×10^6	100	750	4000	60	1.173	0.155	125	0.008	W19
R3559TD20R	R1966DH20	2000	3559	38900	7.57×10^6	140	750	4000	60	1.173	0.155	125	0.008	W19
R3559TD20T	R1966DH20	2000	3559	38900	7.57×10^6	200	750	4000	60	1.173	0.155	125	0.008	W19
R3708FC40V	R1386CH40	4000††	3708	50000	12.5×10^6	250	4000	4000	60	1.473	0.156	125	0.0065	W15
R3708FC40W	R1386CH40	4000††	3708	50000	12.5×10^6	300	4000	4000	60	1.473	0.156	125	0.0065	W15
R3708FC45V	R1386CH45	4500††	3708	50000	12.5×10^6	250	4000	4000	60	1.473	0.156	125	0.0065	W15
R3708FC45W	R1386CH45	4500††	3708	50000	12.5×10^6	300	4000	4000	60	1.473	0.156	125	0.0065	W15
R3708FD40V	N/A	4000††	3708	50000	12.5×10^6	250	4000	4000	60	1.473	0.156	125	TBC	W48
R3708FD40W	N/A	4000††	3708	50000	12.5×10^6	300	4000	4000	60	1.473	0.156	125	TBC	W48
R3708FD45V	N/A	4500††	3708	50000	12.5×10^6	250	4000	4000	60	1.473	0.156	125	TBC	W48
R3708FD45W	N/A	4500††	3708	50000	12.5×10^6	300	4000	4000	60	1.473	0.156	125	TBC	W48
RX075FC24R	N/A	2400	3814	64500	20.8×10^6	140	1800	4000	60	1.568	0.133	125	0.0065	W15
RX075FC24T	N/A	2400	3814	64500	20.8×10^6	200	1800	4000	60	1.568	0.133	125	0.0065	W15
RX075FC28R	N/A	2800	3814	64500	20.8×10^6	140	1800	4000	60	1.568	0.133	125	0.0065	W15
RX075FC28T	N/A	2800	3814	64500	20.8×10^6	200	1800	4000	60	1.568	0.133	125	0.0065	W15
RX075FD24R	N/A	2400	3814	64500	20.8×10^6	140	1800	4000	60	1.568	0.133	125	TBC	W48
RX075FD24T	N/A	2400	3814	64500	20.8×10^6	200	1800	4000	60	1.568	0.133	125	TBC	W48
RX075FD28R	N/A	2800	3814	64500	20.8×10^6	140	1800	4000	60	1.568	0.133	125	TBC	W48
RX075FD28T	N/A	2800	3814	64500	20.8×10^6	200	1800	4000	60	1.568	0.133	125	TBC	W48

NB: †† - V_{rm} 3000V max

Under development



Fig. W9
Weight 90 g



Fig. W10a
Weight 340 g



Fig. W11
Weight 510 g



Fig. W11a
Weight 510 g



Fig. W13
Weight 1700 g



Fig. W14
Weight 1300 g

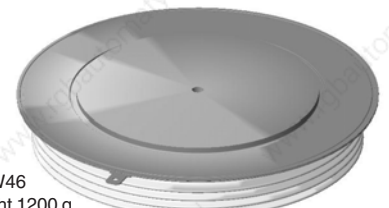

Fig. W46
Weight 1200 g



Fig. W19
Weight 1700 g



Fig. W15
Weight 2800 g



Fig. W48
Weight 1000 g

We offer a broad range of high specification devices incorporating advanced features such as buffer layer, fine pattern and transparent emitter technologies.

Offering both symmetrical devices for applications with a reverse blocking requirement e.g. current sourced inverters and anode shorted devices for applications where no reverse blocking requirement exists e.g. voltage sourced inverters.

Devices with voltage ratings to 6kV (3.8kV DC link) and controllable current ratings of up to 4kA are available to meet the toughest demands in applications such as traction propulsion and auxiliaries, AC industrial drives, FACTs and active VAR controllers.

Gate Turn-Off Thyristors are still the component of choice when it comes to very high power converters and we remain totally committed to this technology for the foreseeable future.

Gate Turn-Off Thyristors - Capsule Types

Type		V _{DRM}	V _{RRM}	I _{TGM} @ C _S		I _{TAV} T _K = 55°C	I _{TSM} 10ms ½ sine V _R ≤ 10V	I ² t V _R ≤ 10V A ² s	Typ. Switching Times		V _T I _T =	T _J max	R _{thJK} 180° Sine K/W	Fig. No.
Part No.	Old Part No.	V	V	A	μF	A	kA	A ² s	t _{gt} μs	t _{gr} μs	I _{TGM} V	°C		
S0500KC200	N/A	2000	2000	500	1.0	330	4.0	80 x 10 ³	3.5	10	2.5	125	0.065	W34
S0500KC20Y	N/A	2000	100	500	1.0	330	4.0	80 x 10 ³	3.5	10	2.5	125	0.065	W34
S0500KC25D	N/A	2500	2000	500	1.0	330	4.0	80 x 10 ³	3.5	10	2.5	125	0.065	W34
S0500KC25Y	N/A	2500	100	500	1.0	330	4.0	80 x 10 ³	3.5	10	2.5	125	0.065	W34
S0700KC140	N/A	1400	1400	700	1.5	430	5.0	125 x 10 ³	3.0	10	2.2	125	0.065	W34
S0700KC14Y	N/A	1400	100	700	1.5	430	5.0	125 x 10 ³	3.0	10	2.2	125	0.065	W34
S0700KC17D	N/A	1700	1400	700	1.5	430	5.0	125 x 10 ³	3.0	10	2.2	125	0.065	W34
S0700KC17Y	N/A	1700	100	700	1.5	430	5.0	125 x 10 ³	3.0	10	2.2	125	0.065	W34
S1200NC200	N/A	2000	2000	1200	3.0	790	13.0	840 x 10 ³	4.5	19	2.7	125	0.027	W36
S1200NC20Y	N/A	2000	100	1200	3.0	790	13.0	840 x 10 ³	4.5	19	2.7	125	0.027	W36
S1200NC25D	N/A	2500	2000	1200	3.0	790	13.0	840 x 10 ³	4.5	19	2.7	125	0.027	W36
S1200NC25Y	N/A	2500	100	1200	3.0	790	13.0	840 x 10 ³	4.5	19	2.7	125	0.027	W36
H0500KC200	N/A	2500	2000	500	1.0	280	3.0	45 x 10 ³	2.0	5	3.2	125	0.065	W34
H0500KC20Y	N/A	2500	100	500	1.0	280	3.0	45 x 10 ³	2.0	5	3.2	125	0.065	W34
H0500KC25D	N/A	2500	2000	500	1.0	280	3.0	45 x 10 ³	2.0	5	3.2	125	0.065	W34
H0500KC25Y	N/A	2500	100	500	1.0	280	3.0	45 x 10 ³	2.0	5	3.2	125	0.065	W34
H0700KC140	N/A	1400	1400	700	1.5	360	4.0	80 x 10 ³	3.0	5	2.75	125	0.065	W34
H0700KC14Y	N/A	1400	100	700	1.5	360	4.0	80 x 10 ³	3.0	5	2.75	125	0.065	W34
H0700KC17D	N/A	1700	1400	700	1.5	360	4.0	80 x 10 ³	3.0	5	2.75	125	0.065	W34
H0700KC17Y	N/A	1700	100	700	1.5	360	4.0	80 x 10 ³	3.0	5	2.75	125	0.065	W34
H1200NC200	N/A	2000	2000	1200	3.0	670	10.5	550 x 10 ³	3.0	12	3.3	125	0.027	W36
H1200NC20Y	N/A	2000	100	1200	3.0	670	10.5	550 x 10 ³	3.0	12	3.3	125	0.027	W36
H1200NC25D	N/A	2500	2000	1200	3.0	670	10.5	550 x 10 ³	3.0	12	3.3	125	0.027	W36
H1200NC25Y	N/A	2500	100	1200	3.0	670	10.5	550 x 10 ³	3.0	12	3.3	125	0.027	W36
GX152QC450	N/A	4500	18	1000	1.0	Product under development					125		W35	
GX185QC250	N/A	2500	18	1000	1.0	Product under development					125		W35	
G1000NC450	N/A	4500	18	1000	2.0	545	8.0	320 x 10 ³	4.5	14	4.0	125	0.027	W36
G2000VC250	WG20025SN	2500	18	2000	4.0	1020	16.0	1.28 x 10 ⁶	5.0	24	2.8	125	0.022	W31
G2000VC450	WG20045SN	4500	18	2000	4.0	870	13.0	845 x 10 ³	8.0	25	3.5	125	0.022	W31
G3000TC250	WG30025SN	2500	18	3000	5.0	1640	30.0	4.50 x 10 ⁶	3.0	25	2.5	125	0.015	W32
G3000TC450	WG30045SN	4500	18	3000	6.0	1180	24.0	2.88 x 10 ⁶	9.0	28	4.0	125	0.015	W32
G3000TC600	WG30060SN	6000	18	3000	3.0	1100	24.0	2.88 x 10 ⁶	7.5	28	3.5	110	0.015	W32
G4000EC450	WG40045SN	4500	18	4000	6.0	1270	25.0	3.13 x 10 ⁶	7.5	28	4.4	125	0.014	W33

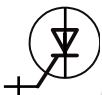

Fig. W31
Weight 800 g



Fig. W32
Weight 1500 g

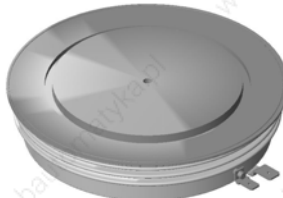
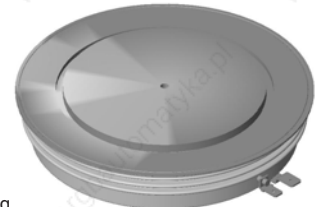

Fig. W33
Weight 1500 g



Under
development

Fig. W34
Weight 120 g



Fig. W35
Weight approx 300 g
Product in development

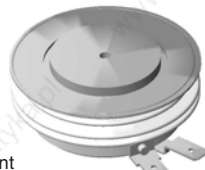

Fig. W36
Weight 500 g



Pulse Thyristors

We have long since been at the forefront of solid state pulsed power technology, offering custom solutions to complex pulsed power problems. Pulse thyristors are, in essence, optimised Gate Turn-Off thyristors and as such we are able to offer a flexible range of parts depending upon customer needs.

Devices with voltage ratings to 6kV (3.8kV DC link), pulsed currents to 150kA peak and di/dt capabilities to over 30kA/μs are available.

A selection of preferred parts is shown here, for other parts and technical support please contact the Westcode factory.



Pulse Thyristors - Capsule Types

Type		V_{DRM} $V_{GK=}$ -2V	V_{RRM}	V_{DC} $V_{GK=}$ -2V	I_{PULSE}	di/dt_{cr}	V_{T0} @ $T_{j max}$	r_T	$T_{j max}$	R_{thJK} d.c. 180° sine K/W	Fig. No.
Part No.	Old Part No.	V	V	V	kA	kA/μs	V	mΩ	°C		
Y2002KC250	N/A	2500	2000	1500	20	5	1.216	2.196	125	0.065	W34
Y5002NC250	N/A	2500	2000	1500	50	11	1.755	1.122	125	0.027	W36
Y8002VC450	N/A	4500	17	2200	80	15	1.800	0.850	125	0.022	W31



Fig. W34
Weight 120 g



Fig. W31
Weight 800 g



Fig. W36
Weight 500 g

As a pioneer of Press-Pack IGBT technology, we are able to offer a range of class leading devices with voltage ratings of 2.5kV (1.25kV DC link) and 4.5kV (2.8kV DC link).

The construction of these devices is totally free from wire and solder bonds which all but eliminates the problems of mechanical fatigue associated with conventional modules. Internal stray inductance in both the gate connections and emitter connections is vastly reduced when compared to conventional modules leading to improved ruggedness and short circuit behaviour, which is further enhanced by direct cooling of the emitter side of the chip.

These devices are based on a state-of-the-art soft punch through (SPT) process, which yields exceptional values $V_{CE(sat)}$ and quiet switching behaviour despite the high voltage ratings, yet the devices feature a positive temperature coefficient making them suitable for reliable parallel operation.

Devices are available with or without integral anti-parallel diode – a range of complementary High Power Sonic-FRDs™ optimised for use with these IGBTs are available, please contact your representative for further details.

The press pack construction offers several advantages over conventional IGBT modules.

- They exhibit exceptional power cycling performance – typically an order of magnitude better than modules – making them highly suited to applications such as induction heating and mass transits where there are repeated cyclic power demands.

- They are explosion rated making them a good choice in critical applications such as mining, the petro-chemical industry, and transportation applications.
- They have a stable short circuit failure mode which, as well as safety benefits, makes them an ideal choice for medium and high voltage applications where series connection is required. Press-pack construction is the obvious choice where series connection is needed and the short circuit failure mode allows for the design in of n+1 redundancy. Typical examples include HVDC, active VAR controllers and medium voltage drives.
- They are largely backwardly compatible with standard 2.5kV and 4.5kV Gate Turn-Off thyristors (including GCTs) in many applications such as AC drives. This makes these parts a simple and economical path to upgrade or refurbish equipment that previously used Gate Turn-Off thyristors, such as locomotives or medium voltage drives.
- They are suitable for all cooling options including direct liquid immersion.
- Applications include Medium Voltage drives, traction (main drives and auxiliaries), Utilities (HVDC and Active VAR controllers), motor control, pulsed power and induction heating power supplies. Press-pack IGBTs are particularly suited to Safety critical applications for the mining and petrochemical industries.
- Complementary gate drives, mounting clamps and passive components are available.

Press-Pack IGBTs - Capsule Types

Type Part No.	V_{CES} V	I_C A	I_{CM} A	$V_{CE(sat)}$ $I_C=I_C$ V	IGBT Switching Typical		V_F $I_F=I_C$ V	Diode Recovery Typical			$T_j \text{ max}$ °C	R_{thJK}		Fig. No.
					E_{ON} J	E_{OFF} J		I_{rm} A	t_{rr} µs	Q_r µC		IGBT K/W	Diode K/W	
T0160NA45A	4500	160	310	4.6	0.50	0.42	3.6	400	0.96	340	125	0.058	0.095	W40
T0240NA45E	4500	240	400	4.7	0.73	0.88	N/A	N/A	N/A	N/A	125	0.042	N/A	W40
T0360NA25A	2500	360	720	3.6	0.75	0.34	2.5	250	0.93	285	125	0.054	0.087	W40
T0500NA25E	2500	500	1000	3.6	0.80	0.50	N/A	N/A	N/A	N/A	125	0.039	N/A	W40
T0600TA45A	4500	600	1000	4.7	1.75	1.50	3.6	1400	0.92	650	125	0.016	0.039	W41
T0800TA45E	4500	800	1500	4.6	2.20	1.92	3.6	N/A	N/A	N/A	125	0.012	N/A	W41
T0900EA45A	4500	900	1500	4.6	2.80	2.60	3.6	1800	0.85	800	125	0.014	0.026	W44
T1200TA25A	2500	1200	2400	3.6	2.50	1.40	2.5	670	1.50	830	125	0.017	0.029	W41
T1200EA45E	4500	1200	2100	4.6	3.20	3.80	3.6	N/A	N/A	N/A	125	0.010	N/A	W44
T1500TA25E	2500	1500	3000	3.6	3.30	1.70	N/A	N/A	N/A	N/A	125	0.013	N/A	W41
T1800GA45A	4500	1800	3000	4.7	TBC	TBC	3.6	TBC	TBC	TBC	125	0.008	0.014	W45
T2400GA45E	4500	2400	4200	4.7	TBC	TBC	3.6	TBC	TBC	TBC	125	0.005	N/A	W45
TX168NA17A	1700	Products under development											W40	
TX167NA17E	1700												W40	
TX115TA17A	1700												W41	
TX116TA17E	1700												W41	

Under development



High Voltage IGBT Gate Drive Units – C0030BG400

The C0030BG400 is a single channel 30A peak rated gate drive unit (GDU), suitable for low and high side applications with DC link voltages of up to 3.5kV (5kV available on request) and with dv/dt immunity of over 100kV/μs.

This GDU performs all of the necessary supervisory functions including under voltage lockout and SCSOA protection with user configurable response and feedback. The unit requires a simple 15V DC power supply and features fibre optic command and feedback signals.

This GDU is capable of driving virtually all IGBTs including our range of press-pack devices at frequencies from DC up to 20kHz with no duty cycle limitations.

Options include standard variants set up for use with each of Westcode's range of IGBTs (see table) and the core module for integration into end user PCBs. Additionally our application engineers can develop semi-custom solutions based around the standard core module.

Type of IGBT	$R_{g(on)}$ W	$R_{g(off)}$ W	GDU part
T0360NA25A	33	15	C0030BG400SAA
T0500NA25E	22	15	C0030BG400SAB
T1200TA25A	12	6.8	C0030BG400SAC
T1500TA25E	10	6.8	C0030BG400SAD
T0160NA45A	15	8.2	C0030BG400SAK
T0240NA45E	10	8.2	C0030BG400SAL
T0600TA45A	5.6	3.3	C0030BG400SAM
T0800TA45E	4.7	3.3	C0030BG400SAN
T0900EA45A	3.9	2.7	C0030BG400SAP
T1200EA45E	3.3	2.2	C0030BG400SAR

Features

- 30A peak drive current (500ns rise time)
- 10kV AC rms isolation test
- Partial discharge free up to 4kV AC rms
- 100kV/μs dv/dt immunity
- Temperature range -40°C up to +70°C (-55°C up to +80°C available)
- ±15V gate drive voltage
- Standard HP Versatile Link™ Fibre Optic links
- Status feedback signal
- User configurable SCSOA protection



The launch of this new complementary product demonstrates our continued commitment to provide our customers with complete solutions for power electronics and further strengthens our assemblies' capability. This GDU also provides our customers with a rapid route to prototype with our range of high voltage press-pack IGBTs without having to solve the additional problems associated with high isolation voltage gate drives.

Power Semiconductor Assemblies from IXYS and Westcode

WESTCODE

Power Semiconductor Assemblies

From discrete devices to complete assemblies, our customers can procure our products in whatever form suits their needs on a global basis. Supply management is critical to every manufacturer and reducing costs without compromising quality is essential. Our experienced, international, team of engineers is on hand to help our customers to get more from their products and keep at the forefront of technology in an increasingly competitive marketplace.

Standard Assemblies

We have a comprehensive range of standard assemblies for all of the common converter topologies utilising either natural air, forced air or liquid cooling. These well-proven designs provide an economical alternative to in house design and assembly of discrete parts. These assemblies are available on short lead-times to suit most common line voltages and current ratings from 35A to 15kA.

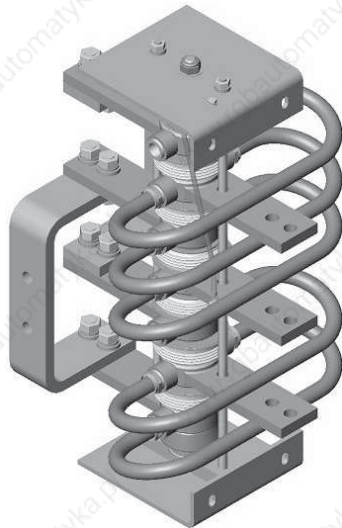
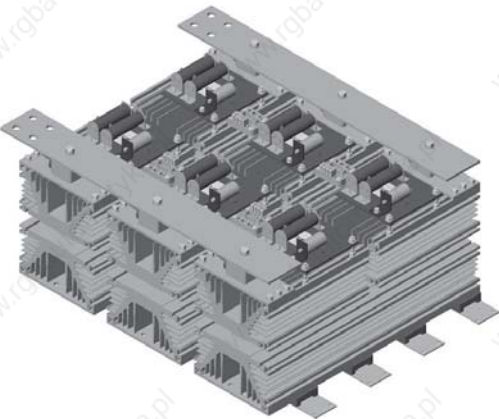

Custom Assemblies

With over 70 years of experience in power circuit design and manufacture, our dedicated team of design engineers can deliver custom solutions for a whole range of design problems ranging from simple crowbar applications to complicated multi-megawatt power converters. Utilising the latest 3D modeling techniques, we can reduce the cycle time from concept to manufacture and ensure successful system level integration into our customers equipment.

Pulsed Power

As a pioneer in the development of solid state pulsed power components and systems, we are able to deliver anything from discrete components to fully integrated energy transfer switches. With systems successfully delivering voltage ratings of over 50kV and pulsed currents to 140kA, we have wealth of experience to put at your disposal. Our modular design solutions based on either pulse thyristor or press-pack IGBT technology and integrating control and protection functions provide you with a flexible "black box" approach to energy transfer problems.



We are involved with pulsed power on global basis, working with prestigious research organisations such as CERN, Switzerland as well as medium volume manufacture for emerging commercial applications such as laser supplies, PUV and PEF sterilisation, magnetisation and metal forming.

We have a philosophy of working closely with our customers to ensure that we deliver the right solution in the right time and right price – first time and every time.

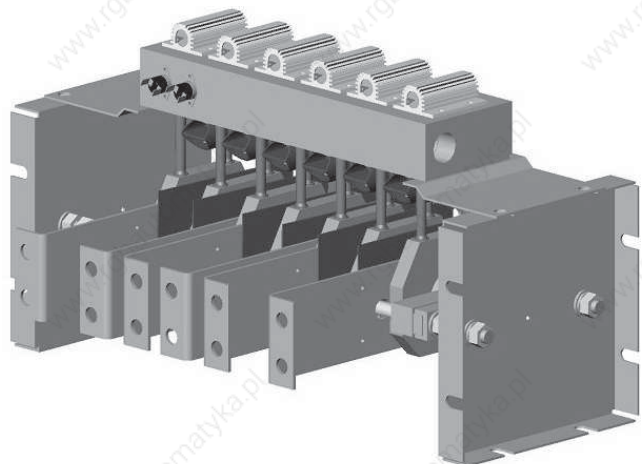

Transportation

We have a long association with the railway industry and over the years have gained an enviable reputation within railway industry as a solution provider. Using our experience and wide ranging contacts within the industry, we are able to offer assistance in tackling issues such as component obsolescence, improving power equipment reliability, contract maintenance of power modules, refurbishment of power electronics and upgrades to existing systems.

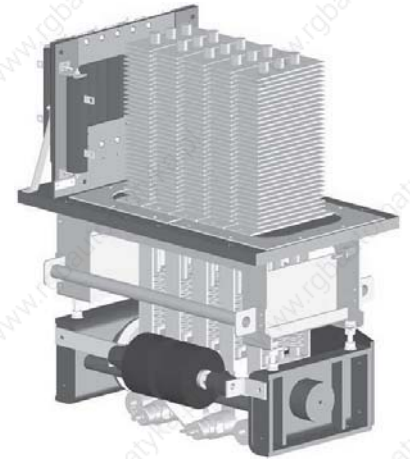
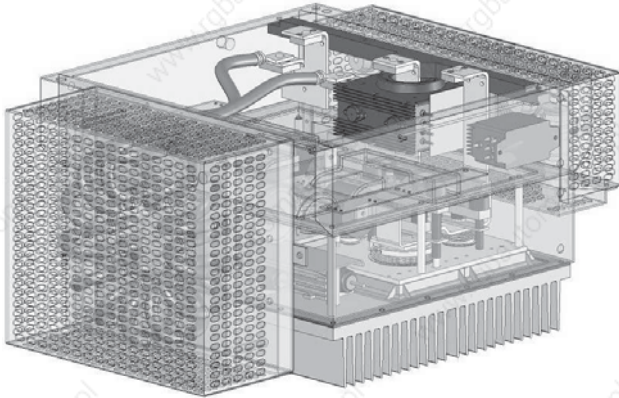

Silicon Assemblies

A wide range of units is available, incorporating international standard outline silicon semiconductors. Westcode products have gained a worldwide reputation for quality in military, industrial and domestic applications.

Standard extruded aluminium heatsink profiles are used for mounting discrete semiconductor devices in various configurations, for example:

- Single-phase diode bridges with current ratings from 70 to 5170 Amps DC
- Single-phase half or fully controlled bridges from 35 to 2200 Amps DC
- Three-phase diode bridges with current ratings from 100 to 7190 Amps DC
- Three-phase half or fully controlled bridges from 45 to 3790 Amps DC
- Hexaphase single way diode assemblies from 200 to 14380 Amps DC
- Hexaphase single way Thyristor assemblies from 90 to 7580 Amps DC
- AC Regulators, single and three phase, from 40 to 2940 Amps RMS

Water Cooled AC Regulators

Included in our standard range are solid state, water cooled AC Regulators for resistance welding, with ratings from 315 to 3020 Amps RMS.

Also available are water cooled, single and three phase assemblies from 1200 to 6000 Amps DC.

All the above range is suitable for 440 VRMS 50Hz mains operation.

Outlines on pages 188 - 224

Working systematically to the highest international standards, we can give your equipment a new lease of life and help protect your investment in these valuable assets. For larger projects, such as fleet wide re-fits, we are able to work within a consortium of specialist companies to ensure that you have the right skills to hand to deliver a turnkey solution to your requirements.

Beyond Semiconductors

Our flexible manufacturing facility is able to readily adapt to our customers needs. In addition to power semiconductor assembly, we can offer complementary sub-assemblies to our customer's requirements, such as fuse panels and capacitor banks as well as contract manufacture to your designs.

Application and Engineering Support

Our highly experienced technical team is on hand to provide our customers with first class support for everything from the application of our range of discrete devices to the design and development of complex systems. We can help you from concept through design to manufacture and test, working closely with you at every step of the way.

Components

We offer a full portfolio of components which are complementary to our range of power semiconductors including:

Heatsinks Coolers Mounting Clamps
Ultra Rapid Semiconductor Protection Fuses
Capacitors for Power Electronics
Gate Drive Units

A standard assembly module provides the basic building block for this new range of assemblies.

Assembly modules can incorporate either single or dual devices and allow for the building of; single-phase diode and thyristor bridges, 3-phase diode and thyristor bridges, or 6-phase single way diode and thyristor assemblies.

A custom built assembly can be provided when a standard solution is not suitable.

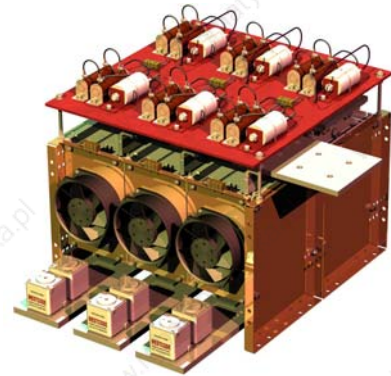

Westack - Modular Solutions

Single phase diode bridges													Approx. total loss $2xI_{DC}$ @ 25°C	
Assembly Part Number	I _{DC} amps Air Forced 2.5m/s			I _{FSM} amps I _{TSM} amps	I ² t A ² s	Dimensions mm				Mass kg	Device Type and Quantity	Heat Sink Type		
	T _a 25°C	T _a 35°C	T _a 45°C			Fig.	W	H	D					
SXB1375B	1375	1303	1230	19500	1.9x10 ⁶	1	382	325	405	20	W2058LC (4)	B(2x83,1x180)		
SXB2096B	2096	1987	1874	33000	5.45x10 ⁶	1	382	325	405	20	W3270NC (4)	B(2x83,1x180)		
SXB3442B	3442	3277	3109	53000	13.5x10 ⁶	2	382	593	405	40	W5696VC (4)	B(2x180)		
SXB4264B	4264	4051	3835	72000	22.5x10 ⁶	2	382	593	405	40	W8405ZC (4)	B(2x180)		
Three phase diode bridges													Approx. total loss 2.5xI _{DC} @ 25°C	
Assembly Part Number	I _{DC} amps Air Forced 2.5m/s			I _{FSM} amps I _{TSM} amps	I ² t A ² s	Dimensions mm				Mass kg	Device Type and Quantity	Heat Sink Type		
	T _a 25°C	T _a 35°C	T _a 45°C			Fig.	W	H	D					
SXB1920G	1920	1822	1721	19500	1.9x10 ⁶	3	548	325	405	30	W2058LC (6)	B(2x83,1x180)		
SXB2939G	2939	2788	2634	33000	5.45x10 ⁶	3	548	325	405	30	W3270NC (6)	B(2x83,1x180)		
SXB4869G	4869	4640	4407	53000	13.5x10 ⁶	4	548	593	405	60	W5696VC (6)	B(2x180)		
SXB5993G	5993	5701	5402	72000	22.5x10 ⁶	4	548	593	405	60	W8405ZC (6)	B(2x180)		
Six phase diode, single way with IPT													Approx. total loss 1.25xI _{DC} @ 25°C	
Assembly Part Number	I _{DC} amps Air Forced 2.5m/s			I _{FSM} amps I _{TSM} amps	I ² t A ² s	Dimensions mm				Mass kg	Device Type and Quantity	Heat Sink Type		
	T _a 25°C	T _a 35°C	T _a 45°C			Fig.	W	H	D					
SXB3840HEX	3840	3644	3442	19500	1.9x10 ⁶	5	548	325	395	30	W2058LC (6)	B(2x83,1x180)		
SXB5877HEX	5877	5576	5268	33000	5.45x10 ⁶	5	548	325	395	30	W3270NC (6)	B(2x83,1x180)		
SXB9737HEX	9737	9281	8813	53000	13.5x10 ⁶	6	548	593	395	60	W5696VC (6)	B(2x180)		
SXB11987HEX	11987	11401	10804	72000	22.5x10 ⁶	6	548	593	395	60	W8405ZC (6)	B(2x180)		
Six phase thyristor, single way with IPT													Approx. total loss 1.5xI _{DC} @ 25°C	
Assembly Part Number	I _{DC} amps Air Forced 2.5m/s			I _{FSM} amps I _{TSM} amps	I ² t A ² s	Dimensions mm				Mass kg	Device Type and Quantity	Heat Sink Type		
	T _a 25°C	T _a 35°C	T _a 45°C			Fig.	W	H	D					
SXB2428HEXT	2428	2233	2030	15000	1.13x10 ⁶	5	548	325	395	30	N1265LS (6)	B(2x83,1x180)		
SXB3529HEXT	3529	3244	2949	29600	4.38x10 ⁶	5	548	325	395	30	N1802NS (6)	B(2x83,1x180)		
SXB4649HEXT	4649	4270	3878	37000	6.85x10 ⁶	6	548	593	395	60	N2500VC (6)	B(2x180)		
SXB6240HEXT	6240	5714	5173	64000	20.5x10 ⁶	6	548	593	395	60	N4085ZC (6)	B(2x180)		
Single phase fully controlled bridges													Approx. total loss 2.5xI _{DC} @ 25°C	
Assembly Part Number	I _{DC} amps Air Forced 2.5m/s			I _{FSM} amps I _{TSM} amps	I ² t A ² s	Dimensions mm				Mass kg	Device Type and Quantity	Heat Sink Type		
	T _a 25°C	T _a 35°C	T _a 45°C			Fig.	W	H	D					
SXB868FB	868	797	724	15000	1.13x10 ⁶	1	382	325	405	20	N1265LS (4)	B(2x83,1x180)		
SXB1265FB	1265	1161	1054	29600	4.38x10 ⁶	1	382	325	405	20	N1802NS (4)	B(2x83,1x180)		
SXB1645FB	1645	1508	1367	37000	6.85x10 ⁶	2	382	593	405	40	N2500VC (4)	B(2x180)		
SXB2167FB	2167	1981	1790	64000	20.5x10 ⁶	2	382	593	405	40	N4085ZC (4)	B(2x180)		
Three phase fully controlled bridges													Approx. total loss 3xI _{DC} @ 25°C	
Assembly Part Number	I _{DC} amps Air Forced 2.5m/s			I _{FSM} amps I _{TSM} amps	I ² t A ² s	Dimensions mm				Mass kg	Device Type and Quantity	Heat Sink Type		
	T _a 25°C	T _a 35°C	T _a 45°C			Fig.	W	H	D					
SXB1214FG	1214	1116	1015	15000	1.13x10 ⁶	3	548	325	405	30	N1265LS (6)	B(2x83,1x180)		
SXB1764FG	1764	1622	1475	29600	4.38x10 ⁶	3	548	325	405	30	N1802NS (6)	B(2x83,1x180)		
SXB2324FG	2324	2135	1939	37000	6.85x10 ⁶	4	548	593	405	60	N2500VC (6)	B(2x180)		
SXB3120FG	3120	2857	2586	64000	20.5x10 ⁶	4	548	593	405	60	N4085ZC (6)	B(2x180)		

Cooling for each module section is provided by the use of a low noise 115/230V ac fan which is protected against overloading by an integral thermal cut-out.

Surge suppression and fusing provides reliable and safe operation. Surge suppression (protecting the devices from voltage transients) and high speed fuses (to protect against short circuit) are available. Contact Westcode for details.

All plastic components are UL recognised and meet the requirements of the European Union Directive 2002/95/EC covering the restricted use of certain hazardous substances in electrical and electronic equipment.

ISO 9000 2000 provides the standard against which all our products and services are measured.

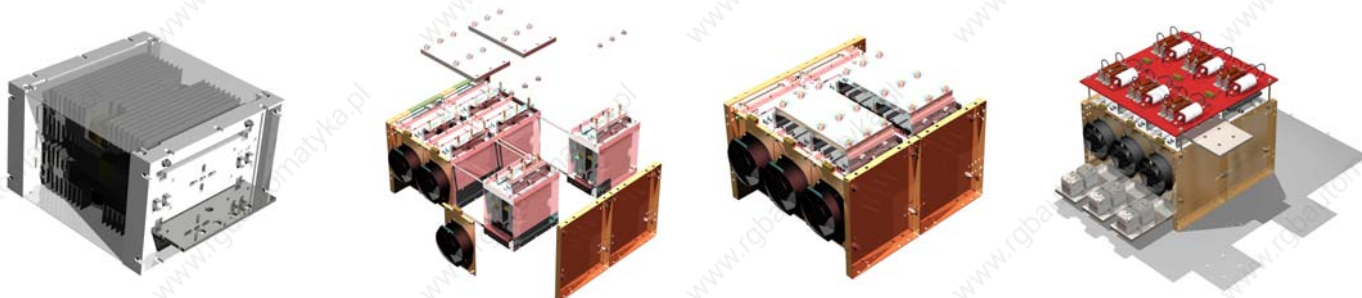

Westack - Modular Solutions are available in 6 standard configurations, others by request.

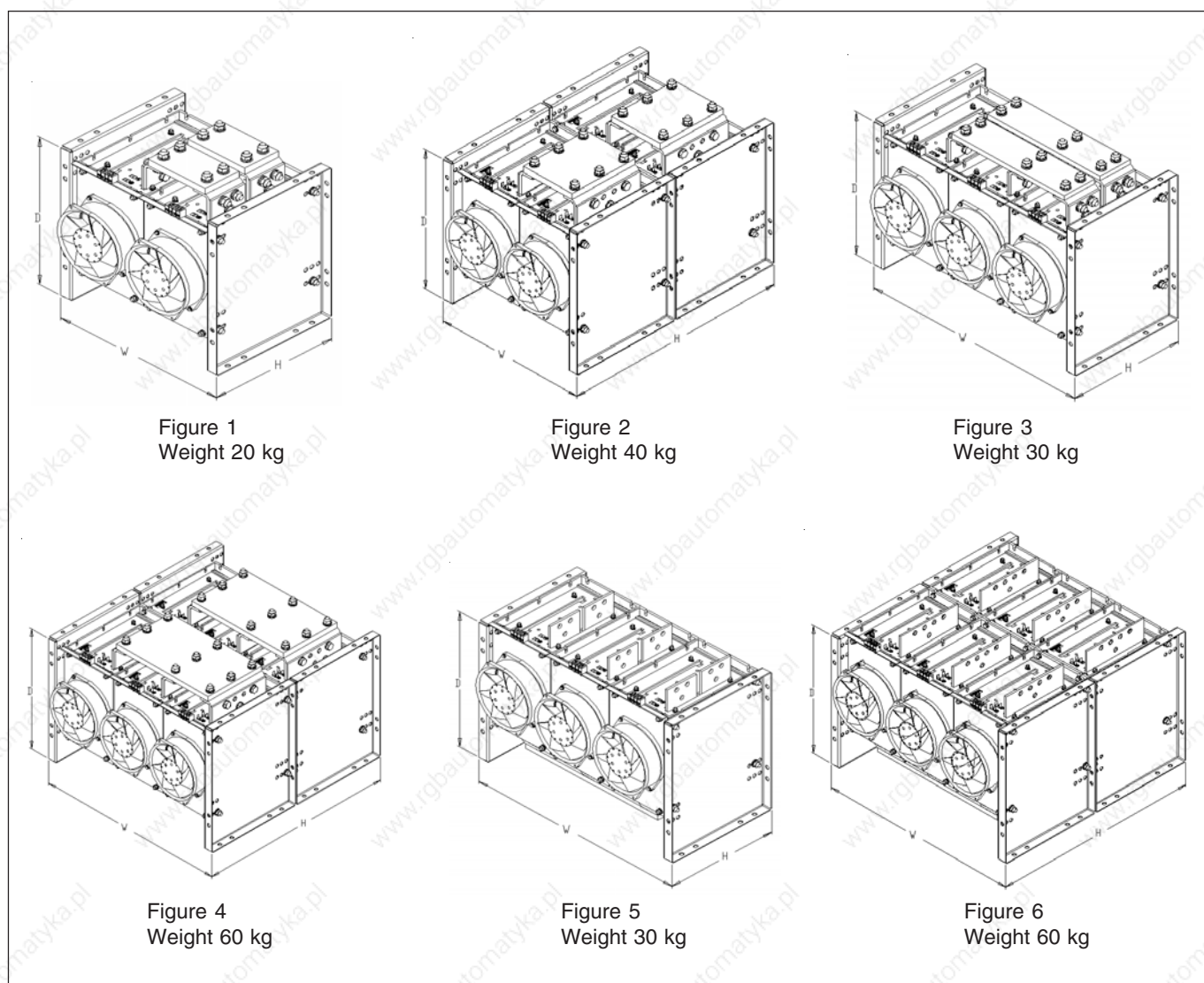

Figure 1
Weight 20 kg

Figure 2
Weight 40 kg

Figure 3
Weight 30 kg

Figure 4
Weight 60 kg

Figure 5
Weight 30 kg

Figure 6
Weight 60 kg

Capsule Mounting Clamps

The "Bar" type clamp uses a two rod system with a straight bar spring that is bent over a central point to give the clamping force on the device. This force is achieved when the indicators, metal shims at each end of the clamp, become just trapped. (CMK 9000 uses a disc spring stack).

The "Box" type clamp uses a four bolt system with disc springs and the correct force on the device is achieved when the bottom of the box just touches the heatsink.

As the force indication is contained within these clamps, special equipment or torque spanners are not required. The clamps can therefore be reset to the correct force at any time, using only a box spanner.

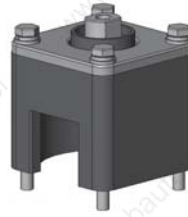

Box clamps are suitable for devices with 19mm, 25mm or 34mm diameter mounting surfaces and of 13.8mm, 14.6 or 26.2mm nominal thicknesses respectively.



Bar clamps are suitable for devices with 19mm to 125mm diameter mounting surfaces and 450kgf to 9000kgf clamping forces.

Bar Type	Fixing Centres mm	Rod Size	Capsule Device		
			Outline	Mounting Surface Diameter mm	Nominal Thickness mm
CMK450S56M CMK450D56M CMK450DT56M	65	M8	DO-200AA/TO-200AB	19.0	13.8
CMK550S56M CMK550D56M	65	M8	GTO	29.5	16.0
CMK900S56M CMK900D56M CMK900DT56M	65	M8	Diode/Thyristor	25.1	14.6
CMK0600S74M CMK0600D74M	89	M10	Press-Pack IGBTs	47.0	27.0
CMK1000S74M CMK1000D74M	89	M10	Press-Pack IGBTs	47.0	27.0
CMK1100D76M	89	M10	DO-200AB/TO-200AC	34.0	26.2
CMK1130S76M CMK1130D76M CMK1130DT76M	89	M10	DO-200AB/TO-200AC	34.0	26.2
CMK1800S76M CMK1800D76M CMK1800DT76M	89	M10	Wespack PCT	38.0	14.0
CMK2100S76M* CMK2100D76M*	89	M10	GTO	47.0	27.0
CMK2140S76M* CMK2140D76M* CMK2140DT76M*	89	M10	DO-200/Thyristor	47.0	26.8
CMK2700S76M CMK2700D76M CMK2700DT76M	89	M10	Wespack PCT	50.0	14.0

Bar Type	Fixing Centres mm	Rod Size	Capsule Device		
			Outline	Mounting Surface Diameter mm	Nominal Thickness mm
CMK2000S114M CMK2000D114M	132	M12	Press-Pack IGBTs	75.0	26.0
CMK2500S114M CMK2500D114M	132	M12	Press-Pack IGBTs	75.0	26.0
CMK2500S116M* CMK2500D116M*	132	M12	GTO	63.0	26.0
CMK3000S116M* CMK3000D116M*	132	M12	DO-200AD/Thyristor	63.0	33.0
CMK3500S116M* CMK3500D116M*	132	M12	GTO	75.0	26.0
CMK4000S116M* CMK4000D116M*	132	M12	Diode/Thyristor	73.0	36.8
CMK5000D128M* CMK7000D128M*	146	M16	GTO	75.0	26.0
CMK3060S140ML CMK3060D140ML	154	M12	Press-Pack IGBTs	85.1	26.0
CMK9000S160M* CMK9000D160M*	180	M16	Thyristor	99.3	35.8
CMK6120S180ML CMK6120D180ML	196	M16	Press-Pack IGBTs	125.0	26.0

* M for T_j up to 190°C, ML for T_j 125°C.

Note: 1Kgf = 9.8 Newtons

Outline Drawings for both Bar and Box type Clamps are available from Westcode via the website

www.westcode.com

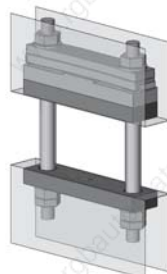

CMK	XXXX	S, D or DT	XX	M
Capsule Mounting Kit	Nominal Clamping Force Kgf	S-Single side cooled (tapped heatsink) D-Double side cooled (through hole in heatsink) DT-Double side cooled (tapped heatsink)	Maximum Capsule Diameter mm	Metric Fixings M8, 10 or 12

Box Type	Fixing Centres mm	Rod Size	Capsule Device		
			Outline	Mounting Surface Diameter mm	Nominal Thickness mm
CMK450B 19M CMK450B 25M CMK1500B 34M	50 PCD 70 PCD	M5x50 Bolts M6x50 Bolts	DO-200AA/TO-200AB Diode/Thyristor DO-200AB/TO-200AC	19.0 25.1 34.0	13.8 14.6 26.2

Note: 1Kgf = 9.8 Newtons



CMK	XXX	B	XX	M
Capsule Mounting Kit	Nominal Clamping Force Kgf	Box Clamp	Capsule Mounting Surface Diameter 19, 25 or 34mm	Metric Fixing Bolts (See Chart)

Coolers and Heatsinks

A comprehensive range of coolers and heatsinks are offered, details available upon request.

Heatsink Type	Weight Kg/m	Periphery mm	Area mm ²
G Fin	8.1	1059	2979
GA Fin	15.6	1682	5867
H Fin	12.7	1684	4655
T Fin	20	2065	7573
TB Fin	29	2467	10905
TC Fin	28	2544	10561
LP100 Fin (40 Vane)	30	6620	11172
WS46 Fin	20	2822	7411

WS30 Copper Fin Dimensions 125mm x 125mm x 4 vanes

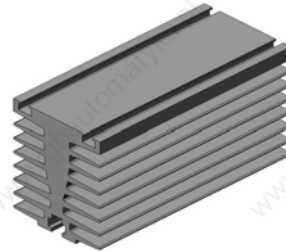

WH1 - G Fin



WH2 - GA Fin

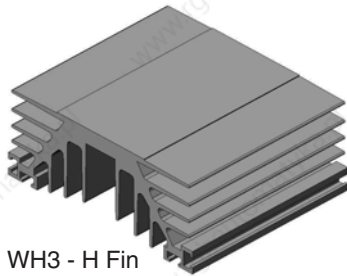

WH3 - H Fin

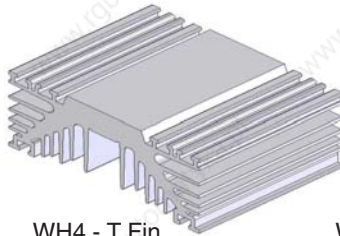

WH4 - T Fin

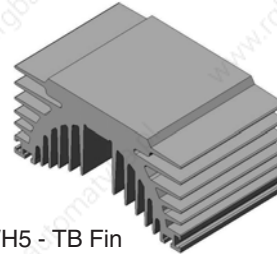

WH5 - TB Fin

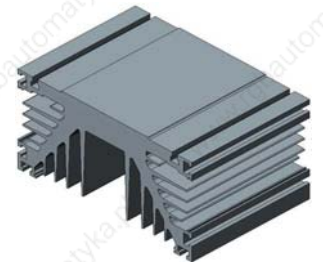

WH6 - TC Fin

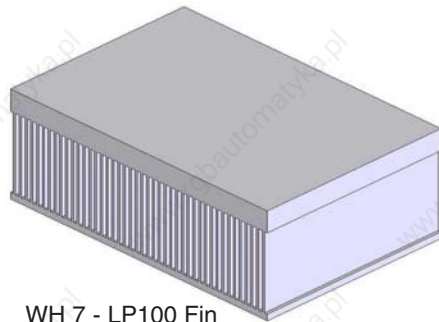

WH7 - LP100 Fin

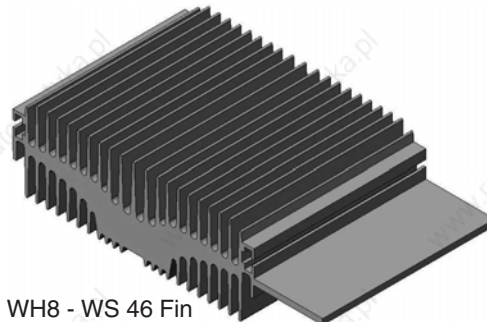

WH8 - WS 46 Fin

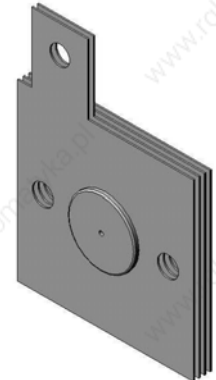

WH9 - WS 30 Copper Fin

Cooler Type	Weight kg	Cooler Thickness mm	Busbar Thickness mm
LK	0.612	16	6,4
LKA	0.418	16	n/a
LKB	1.75	20	10
LKC	1.30	20	n/a
WS27	0.375	15	n/a



WH10 - LK Cooler

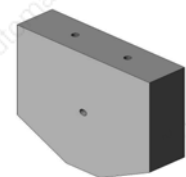

WH11 - LKA Cooler



WH14 - WS 27 Cooler



WH12 - LKB Cooler

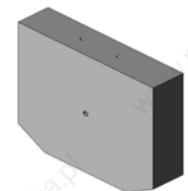

WH13 - LKC Cooler

Dimensions in mm and inches (1 mm = 0.0394")

D1 DE 150

N/C - AN DCB metalized bottom heatsink.
2500 Vrms isolation between leads.
LEADS - Full Silver plating.

D2 DE 275

N/C - AN DCB metalized bottom heatsink.
2500 Vrms isolation between leads.
LEADS - Full Silver plating.

D3 DE 275x2

N/C - AN DCB metalized bottom heatsink.
2500 Vrms isolation between leads.
LEADS - Full Silver plating.

D4 DE 375

N/C - AN DCB metalized bottom heatsink.
2500 Vrms isolation between leads.
LEADS - Full Silver plating.

DE 475

N/C - AN DCB metalized bottom heatsink.
2500 Vrms isolation between leads.
LEADS - Full Silver plating.

Package 754

DIM	INCHES		MILLIMETERS	
	MIN	MAX	MIN	MAX
A	1.330	1.350	33.79	34.21
B	0.370	0.100	9.40	10.41
C	0.190	0.230	4.83	5.84
D	0.215	0.235	5.47	5.96
E	0.050	0.070	1.27	1.77
G	0.430	0.440	10.92	11.18
H	0.102	0.112	2.59	2.84
J	0.004	0.006	0.11	0.15
K	0.185	0.215	4.83	5.33
N	0.845	0.875	21.46	22.23
O	0.060	0.070	1.52	1.78
R	0.390	0.410	9.91	10.41
U	1.100 BSC		27.94 BSC	

DE275-IC

DE150-IC

Outline drawings

Dimensions in mm and inches (1 mm = 0.0394")

Package 81

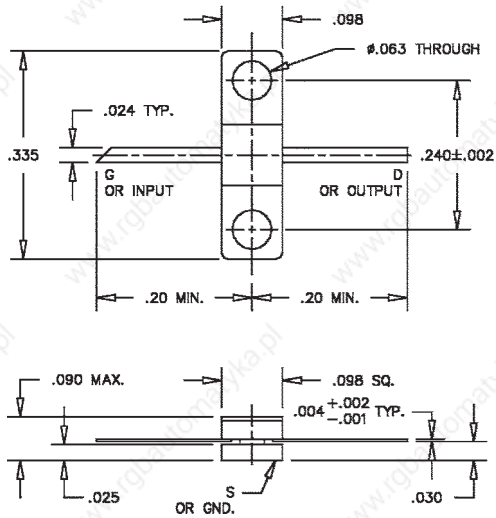

Package 82

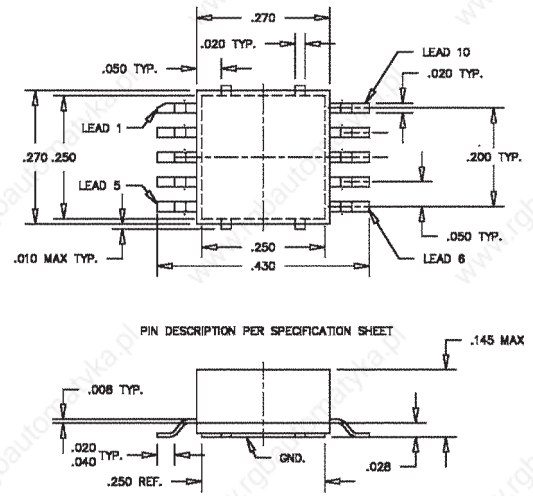

Package 83

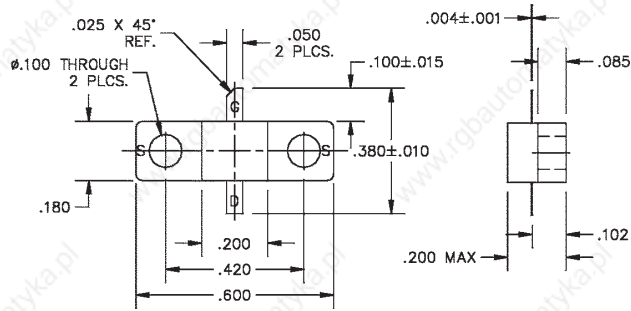

Package 84

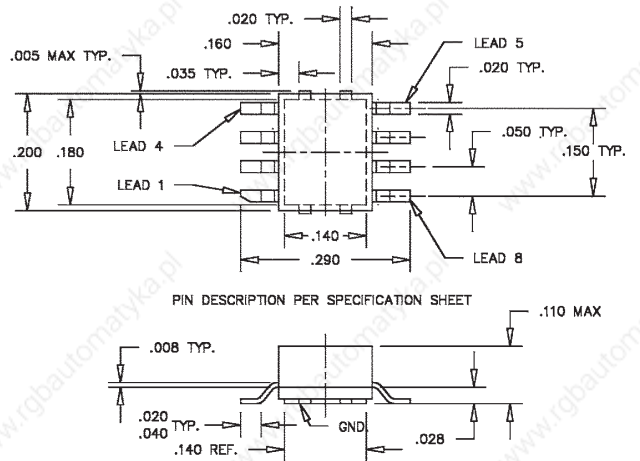

Package 85

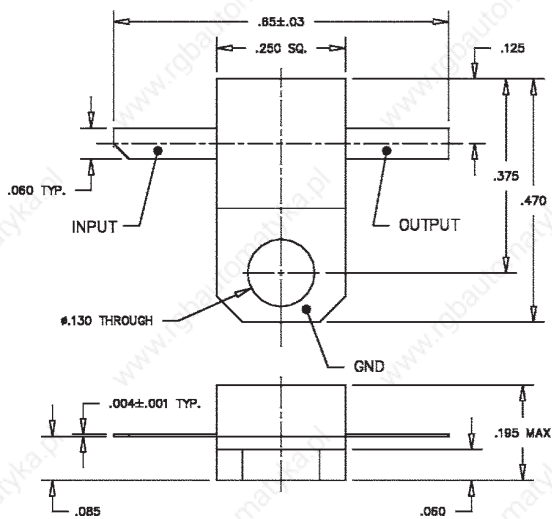

Outline drawings

Dimensions in mm and inches (1 mm = 0.0394")

Package 87

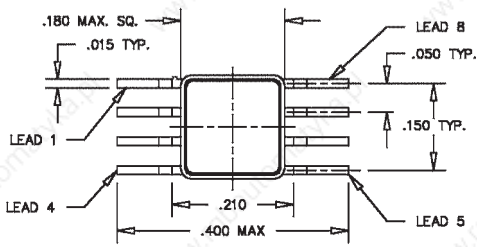

PIN DESCRIPTION PER SPECIFICATION SHEET

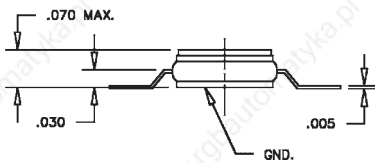

Package 70

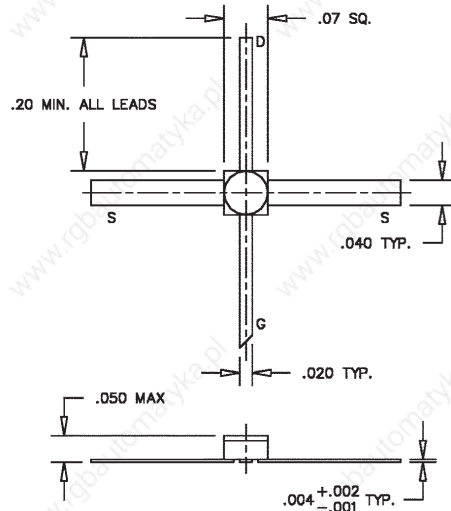

Package 71

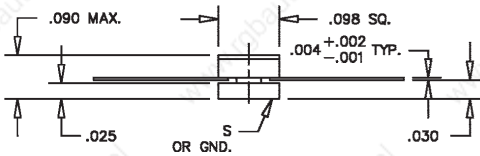
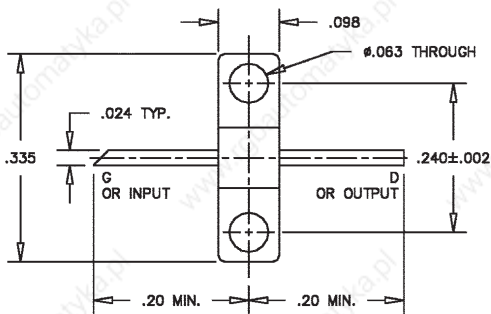

Package 73

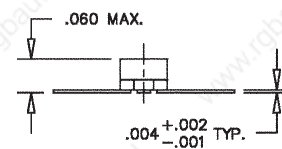
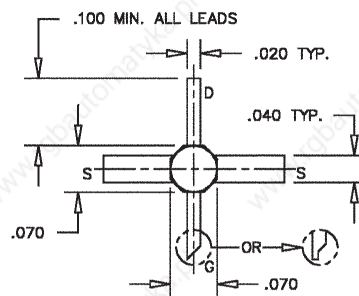

Slim-Pak

SH & SL Housing Series

SMA Female, DC Filter Feedthru
Through Hole Mounting

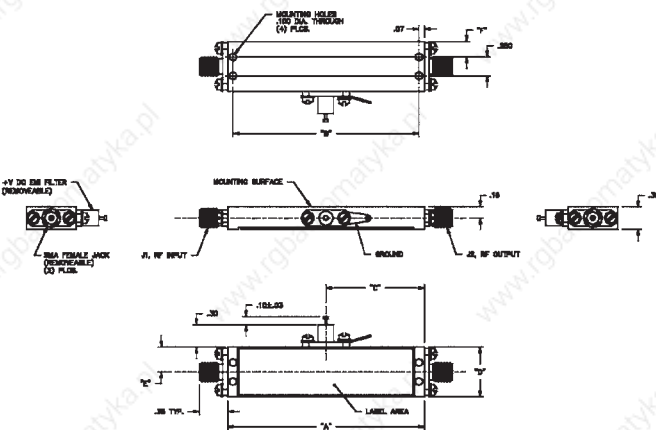

SZ-1

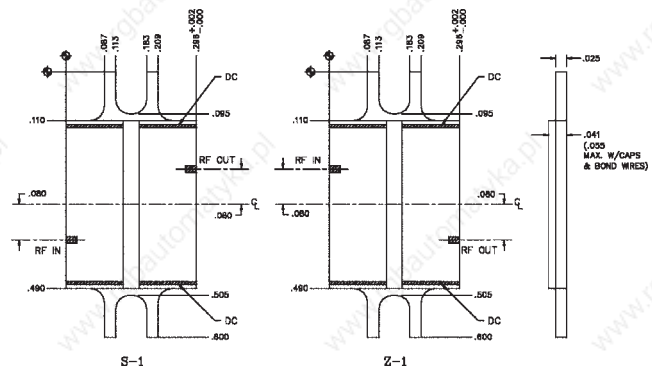

Outline drawings

Dimensions in mm and inches (1 mm = 0.0394")

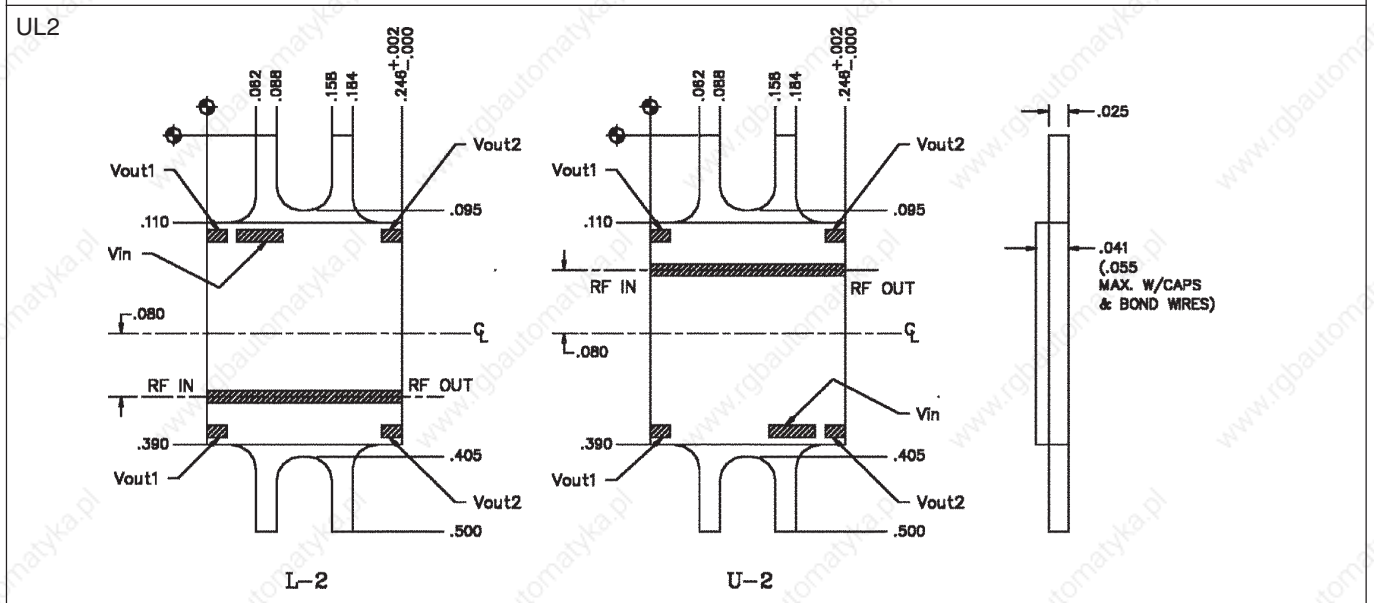
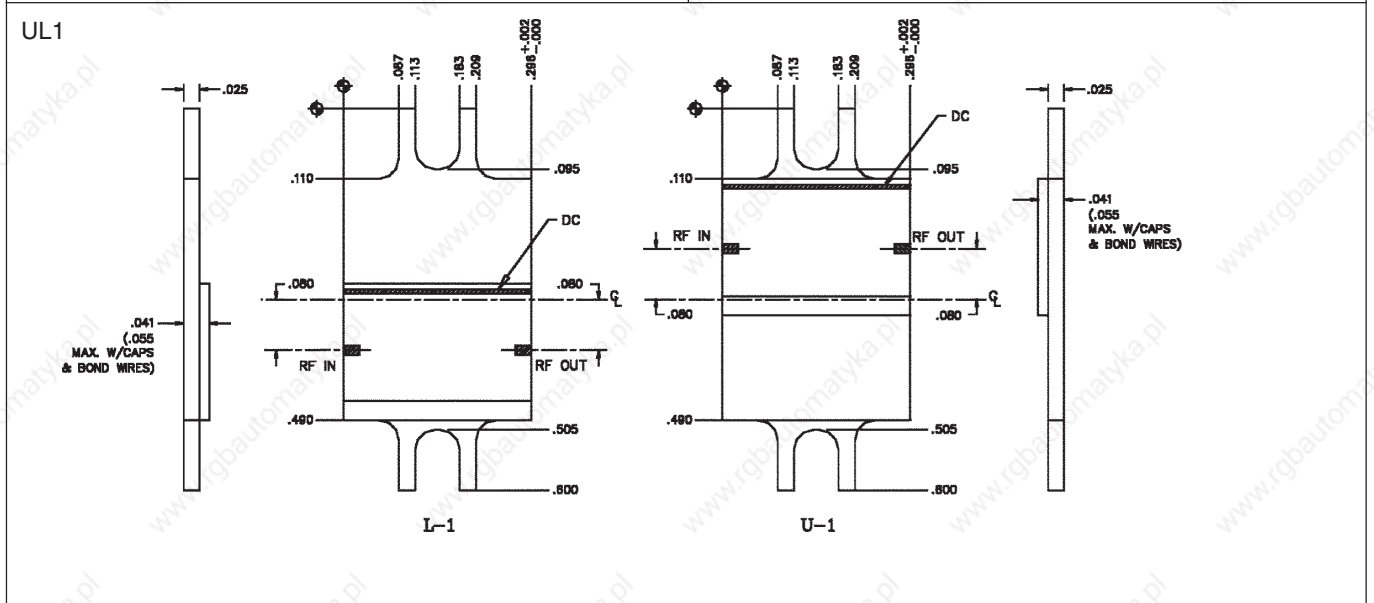
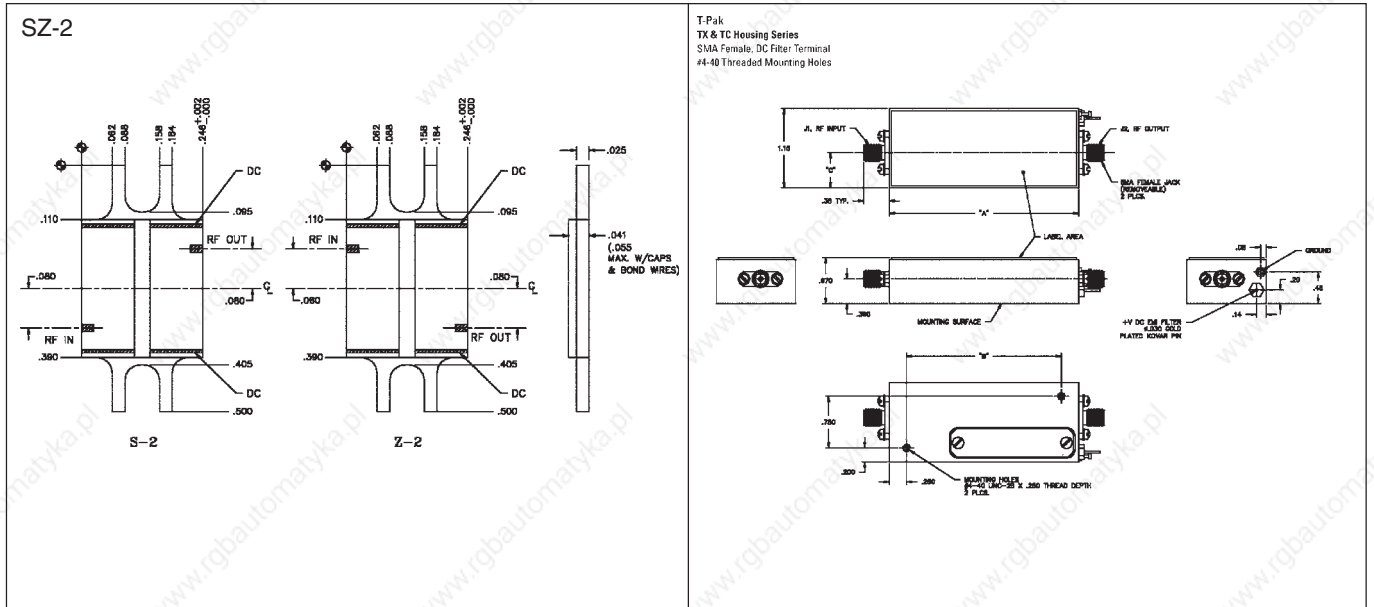

Outline drawings

Dimensions in mm and inches (1 mm = 0.0394")

Package 02

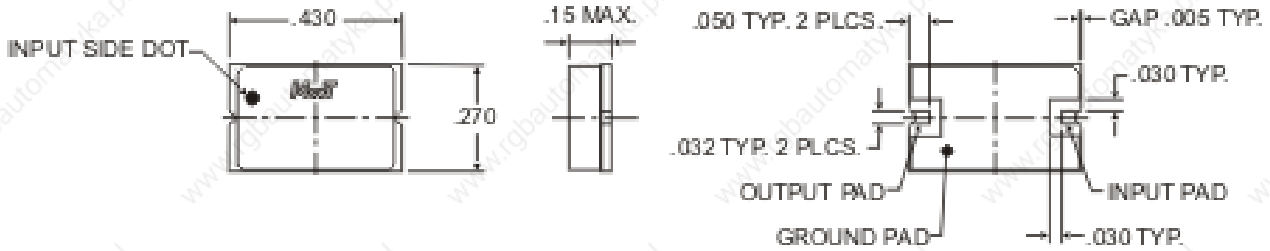

Package 96

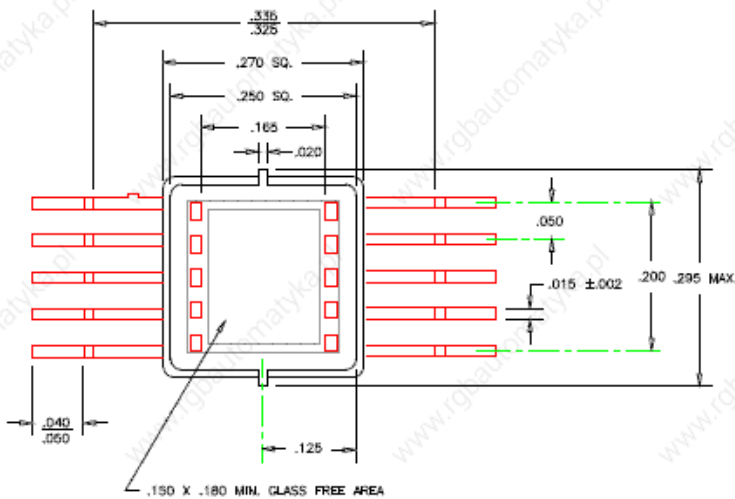

Package -QFN

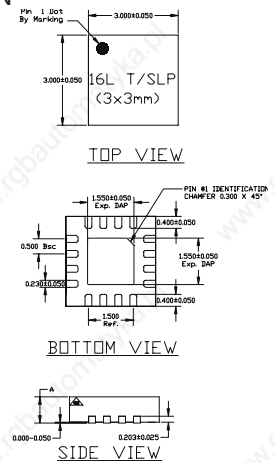
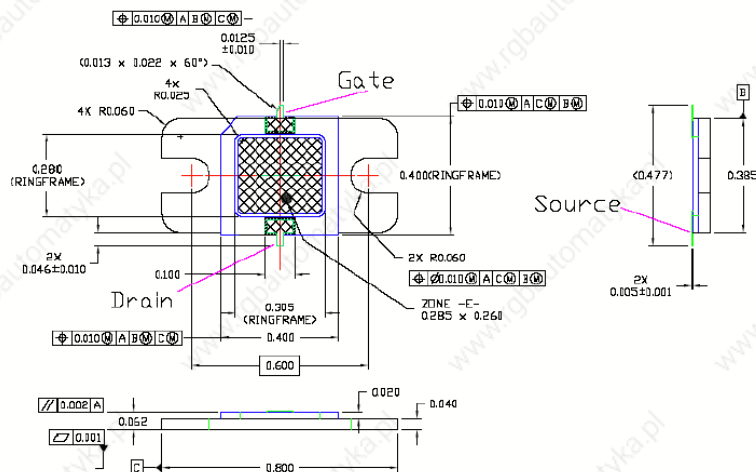

TABLE 1: TSLP AND SLP SHARE THE SAME EXPOSE OUTLINE BUT WITH DIFFERENT THICKNESSES

	TSLP	SLP
MAX.	0.600	0.900
NOM.	0.750	0.850
MIN.	0.700	0.800

Package 99



Package 89

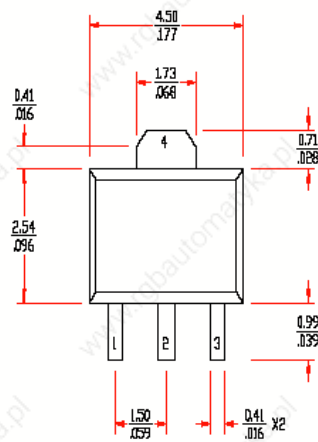

Outline drawings



Dimensions in mm and inches (1 mm = 0.0394")

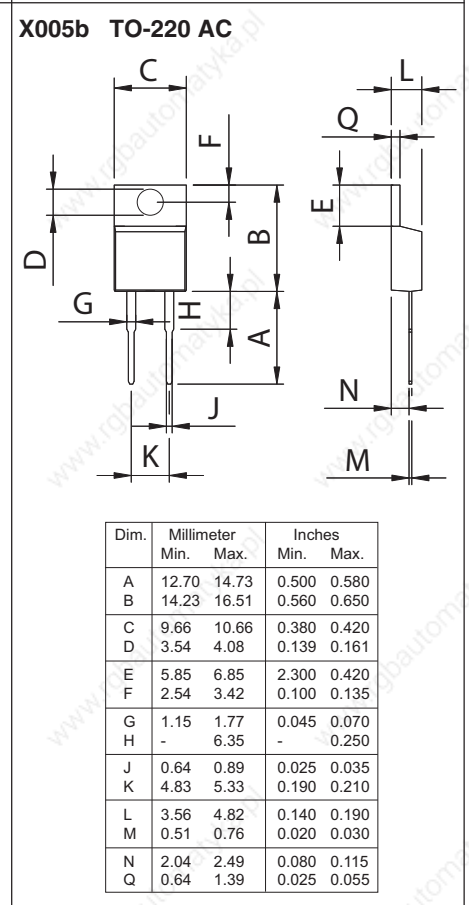
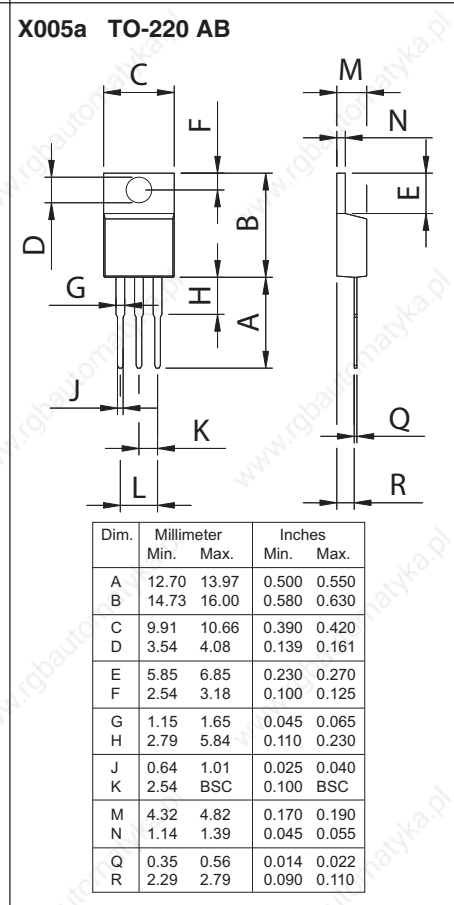
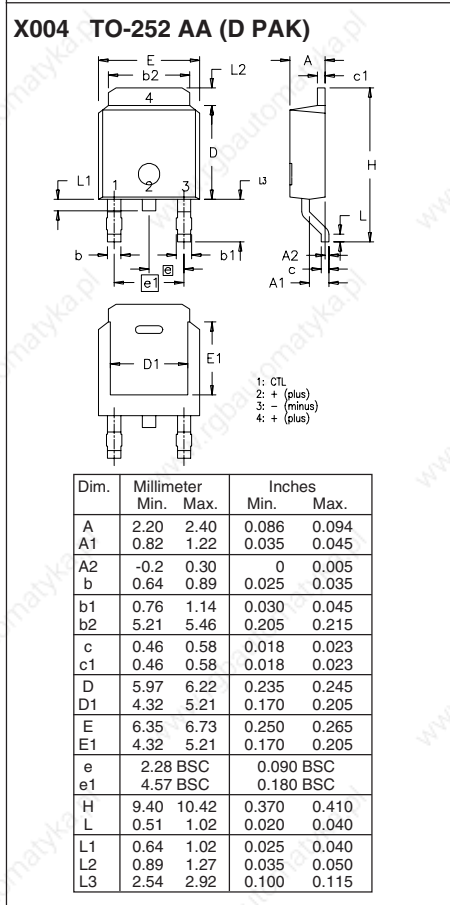
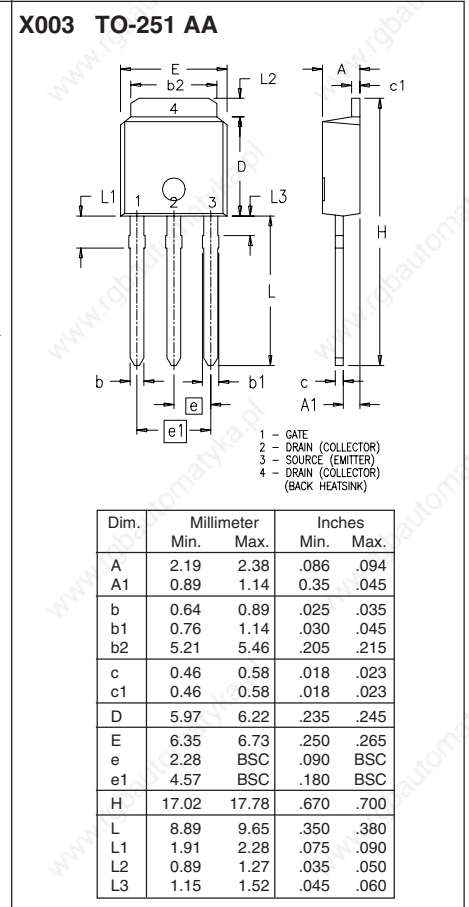
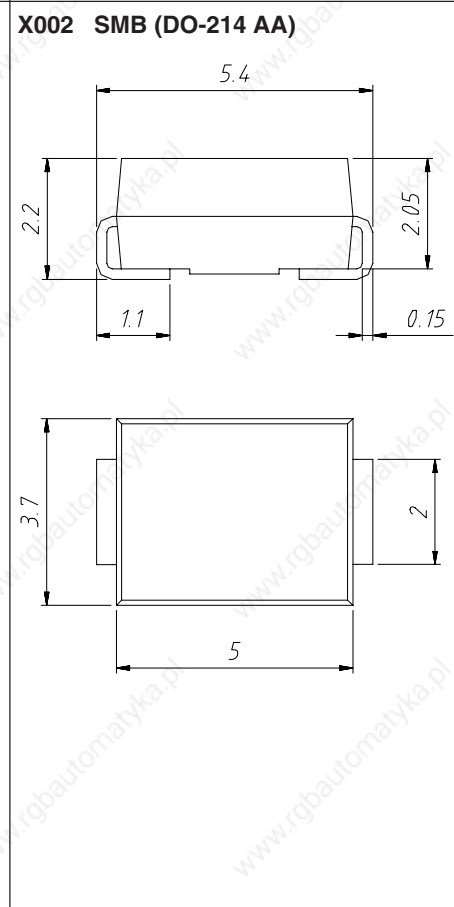
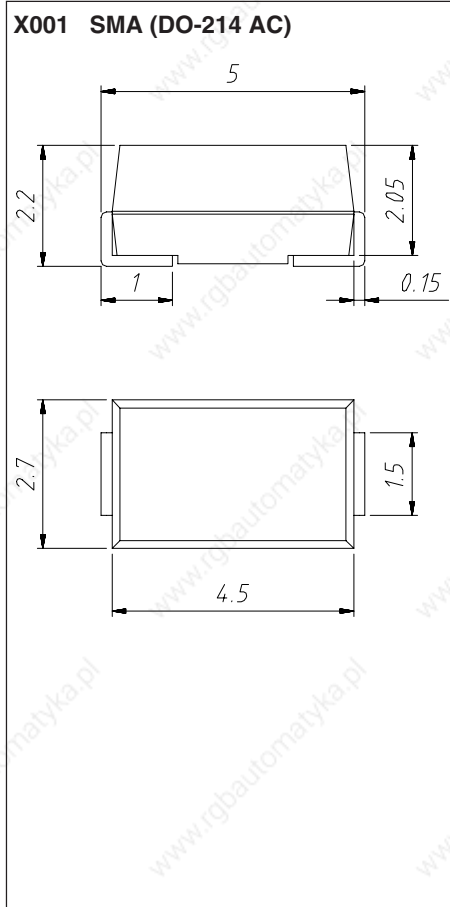

Dimensions in mm and inches (1 mm = 0.0394")

X006 TO-220 (5)

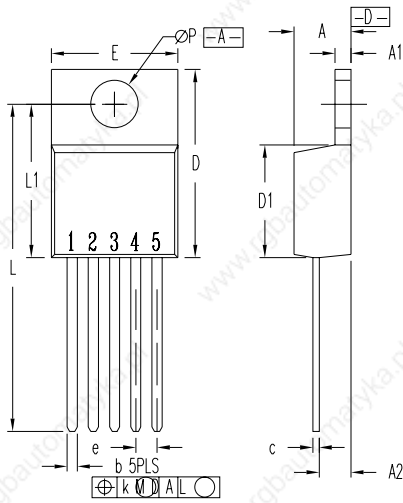

SYM	INCHES		MILLIMETERS	
	MIN	MAX	MIN	MAX
A	.170	.190	4.32	4.83
A1	.045	.055	1.14	1.40
A2	.090	.115	2.29	2.92
b	.025	.040	0.64	1.02
c	.015	.025	0.38	0.64
D	.580	.620	14.73	15.75
D1	.340	.370	8.64	9.40
E	.390	.415	9.91	10.54
e	.067 BSC		1.70 BSC	
k	0	.014	0	0.36
L	.995	1.045	25.27	26.54
L1	.470	.510	11.94	12.95
P	.139	.156	3.53	3.96

X007a TO-220 ABFP

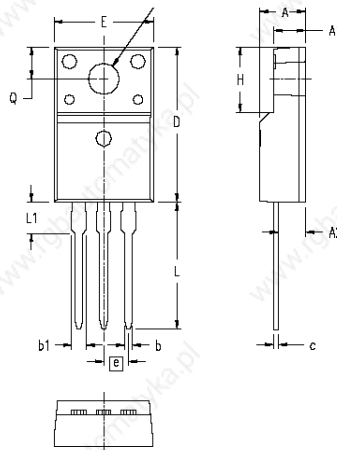

SYM	INCHES		MILLIMETER	
	MIN	MAX	MIN	MAX
A	.177	.193	4.50	4.90
A1	.092	.108	2.34	2.74
A2	.101	.117	2.56	2.96
b	.028	.035	0.70	0.90
b1	.050	.058	1.27	1.47
c	.018	.024	0.45	0.60
D	.617	.633	15.67	16.07
E	.392	.408	9.96	10.36
e	.100BSC		2.54 BSC	
H	.255	.271	6.48	6.88
L	.499	.523	12.68	13.28
L1	.119	.135	3.03	3.43
Ø P	.0121	.129	3.08	3.28
Q	.126	.134	3.20	3.40

X007b TO-220 ACFP

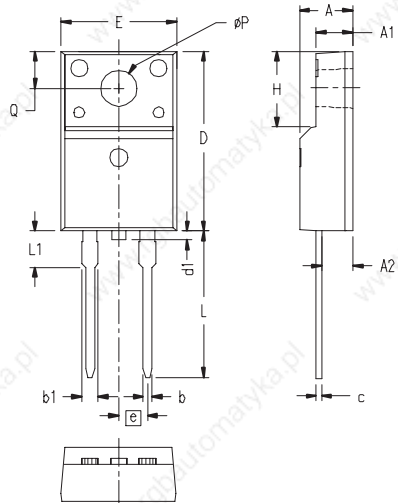

SYM	INCHES		MILLIMETERS	
	MIN	MAX	MIN	MAX
A	.177	.193	4.50	4.90
A1	.092	.108	2.34	2.74
A2	.101	.117	2.56	2.96
b	.028	.035	0.70	0.90
b1	.050	.058	1.27	1.47
c	.018	.024	0.45	0.60
D	.617	.633	15.67	16.07
d1	0	.043	0	1.10
E	.392	.408	9.96	10.36
e	.100 BSC		2.54 BSC	
H	.255	.271	6.48	6.88
L	.499	.523	12.68	13.28
L1	.119	.135	3.03	3.43
ØP	.0121	.129	3.08	3.28
Q	.126	.134	3.20	3.40

X008 TO-262 I²PAK

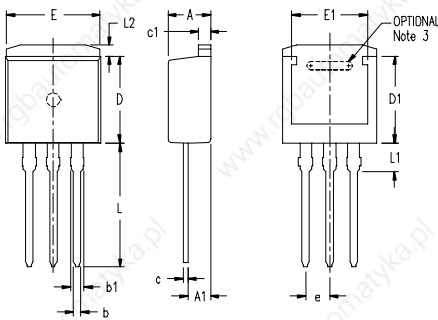

NOTE:
 1. This drawing will meet all dimensions requirement of JEDEC outline TO-262 AA.
 2. All metal surface are matte pure tin plated except trimmed area.
 3. Inter locking slot depends upon frame type.

SYM	INCHES		MILLIMETERS	
	MIN	MAX	MIN	MAX
A	.160	.190	4.06	4.83
A1	.080	.110	2.03	2.79
b	.025	.035	0.64	0.88
b1	.025	.039	1.14	1.40
c	.018	.025	0.46	0.64
c1	.045	.055	1.14	1.40
D	.340	.380	8.64	9.65
D1	.270	.290	6.86	7.37
E	.380	.405	9.65	10.29
E1	.245	.320	6.22	8.13
e	.100 BSC		2.54 BSC	
L	.500	.560	12.70	14.22
L1	.100	.125	2.54	3.18
L2	.040	.055	1.02	1.40

X009 PLUS220

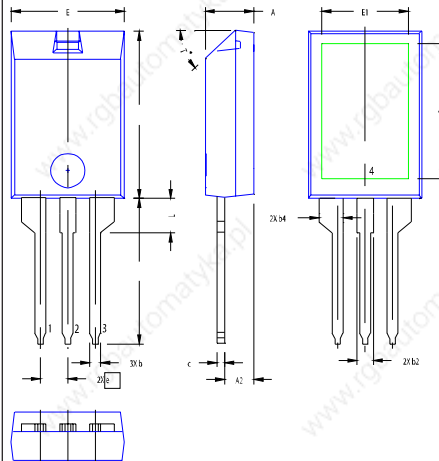

SYM	INCHES		MILLIMETER	
	MIN	MAX	MIN	MAX
A	.157	.197	4.00	5.00
A2	.098	.118	2.50	3.00
b	.035	.051	0.90	1.30
b2	.049	.065	1.25	1.65
b4	.093	1.00	2.35	2.55
c	.028	.039	0.70	1.00
D	.591	.630	15.00	16.00
D1	.472	.512	12.00	13.00
E	.394	.433	10.00	11.00
E1	.295	.335	7.50	8.50
e	.100 BASIC		2.55 BASIC	
L	.512	.571	13.00	14.50
L1	.118	.138	3.00	3.50
T°			42.5°	47.5°

X010a ISOPLUS 220™ AB

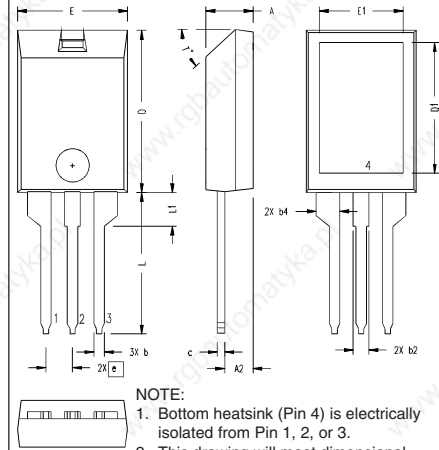

NOTE:
 1. Bottom heatsink (Pin 4) is electrically isolated from Pin 1, 2, or 3.
 2. This drawing will meet dimensional requirement of JEDEC SS Product Outline TO-273 except D and D1 dimension.

SYM	INCHES		MILLIMETERS	
	MIN.	MAX	MIN	MAX
A	.157	.197	4.00	5.00
A2	.098	.118	2.50	3.00
b	.035	.051	0.90	1.30
b2	.049	.065	1.25	1.65
b4	.093	.100	2.35	2.55
c	.028	.039	0.70	1.00
D	.591	.630	15.00	16.00
D1	.472	.512	12.00	13.00
E	.394	.433	10.00	11.00
E1	.295	.335	7.50	8.50
e	.100 BASIC		2.55 BASIC	
L	.512	.571	13.00	14.50
L1	.118	.138	3.00	3.50
T°			42.5°	47.5°

Dimensions in mm and inches (1 mm = 0.0394")

X010b ISOPLUS 220™ AC

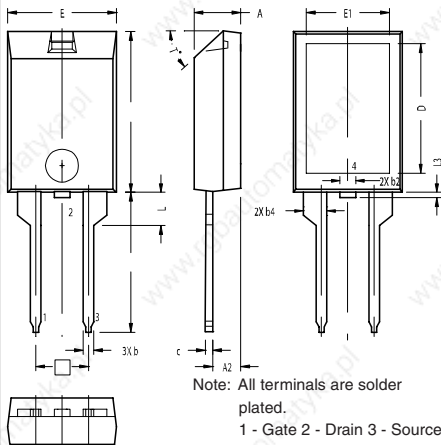

SYM	INCHES		MILLIMETER	
	MIN	MAX	MIN	MAX
A	.157	.197	4.00	5.00
A2	.098	.118	2.50	3.00
b	.035	.051	0.90	1.30
b2	.049	.065	1.25	1.65
b4	.093	.100	2.35	2.55
c	.028	.039	0.70	1.00
D	.591	.630	15.00	16.00
D1	.472	.512	12.00	13.00
E	.394	.433	10.00	11.00
E1	.295	.335	7.50	8.50
e	.200BSC		5.08 BSC	
L	.512	.571	13.00	14.50
L1	.118	.138	3.00	3.50
L2	.035	.051	0.90	1.30
L3	.000	.059	.000	1.50
T°			42.5°	47.5°

X011a TO-263 AA (D²PAK)

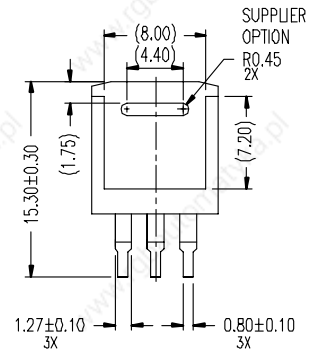
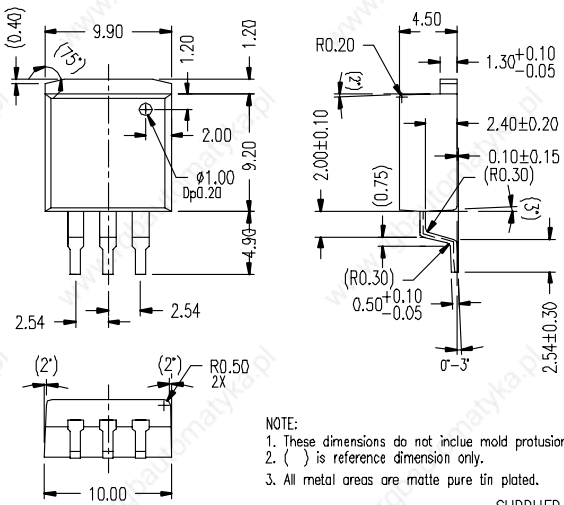

X011b TO-263 AB (D²PAK)

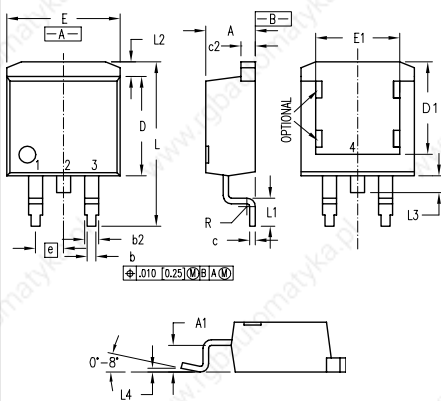

Dim.	Millimeter		Inches	
	Min.	Max.	Min.	Max.
A	4.06	4.83	.160	.190
A1	2.03	2.79	.080	.110
b	0.51	0.99	.020	.039
b2	1.14	1.40	.045	.055
c	0.46	0.74	.018	.029
c2	1.14	1.40	.045	.055
D	8.64	9.65	.340	.380
D1	7.11	8.13	.280	.320
E	9.65	10.29	.380	.405
E1	6.86	8.13	.270	.320
e	2.54	BSC	.100	BSC
L	14.61	15.88	.575	.625
L1	2.29	2.79	.090	.110
L2	1.02	1.68	.040	.066
L3	1.27	1.78	.050	.070
L4	0	0.38	0	.015
R	0.46	0.74	.018	.029

X012a TO-263 (5)

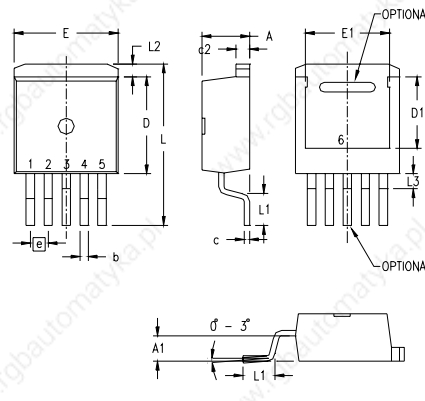

SYM	INCHES		MILLIMETERS	
	MIN	MAX	MIN	MAX
A	.165	.189	4.20	4.80
A1	.083	.106	2.10	2.70
b	.024	.039	0.60	0.99
c	.016	.028	0.40	0.70
c2	.047	.055	1.20	1.40
D	.346	.374	8.80	9.50
D1	.260	.283	6.60	7.20
E	.380	.406	9.65	10.30
E1	.295	.323	7.50	8.20
e	.067BSC		1.70 BSC	
L	.583	.622	14.80	15.80
L1	.088	.112	2.24	2.84
L2	.039	.055	1.00	1.40
L3	.047	.067	1.20	1.70

X012b TO-263 (7)

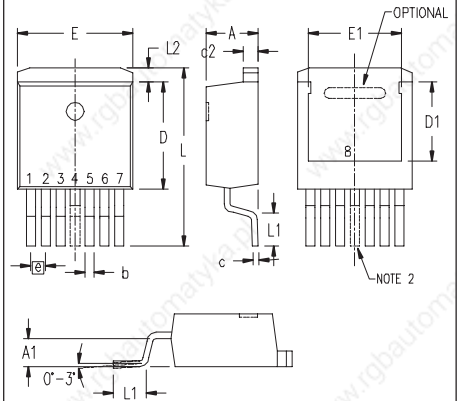

SYM	INCHES		MILLIMETER	
	MIN	MAX	MIN	MAX
A	.165	.181	4.20	4.60
A1	.096	.108	2.45	2.75
b	.026	.035	0.65	0.90
c	.016	.024	0.40	0.60
c2	.045	.055	1.14	1.40
D	.330	.340	8.38	8.64
D1	.240	.250	6.10	6.35
E	.394	.406	10.00	10.30
E1	.290	.315	7.34	8.00
e	.050 BSC		1.27BSC	
L	.580	.620	14.73	15.75
L1	.088	.112	2.24	2.84
L2	.053	.061	1.35	1.55

Dimensions in mm and inches (1 mm = 0.0394")

X013 PLUS220 (SMD)

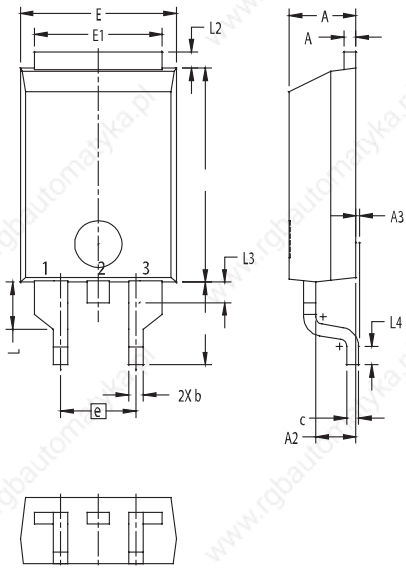

SYM	INCHES		MILLIMETER	
	MIN	MAX	MIN	MAX
A	.169	.185	4.30	4.70
A1	.028	.035	0.70	0.90
A2	.098	.118	2.50	3.00
A3	.000	.010	0.00	0.25
b	.035	.047	0.90	1.20
b1	.080	.095	2.03	2.41
b2	.054	.064	1.37	1.63
c	.028	.035	0.70	0.90
D	.551	.591	14.00	15.00
D1	.512	.539	13.00	13.70
E	.394	.433	10.00	11.00
E1	.331	.346	8.40	8.80
e	.200 BSC		5.08 BSC	
L	.209	.228	5.30	5.80
L1	.118	.138	3.00	3.50
L2	.035	.051	0.90	1.30
L3	.047	.059	1.20	1.50
L4	.039	.059	1.00	1.50

X014a TO-247 AD

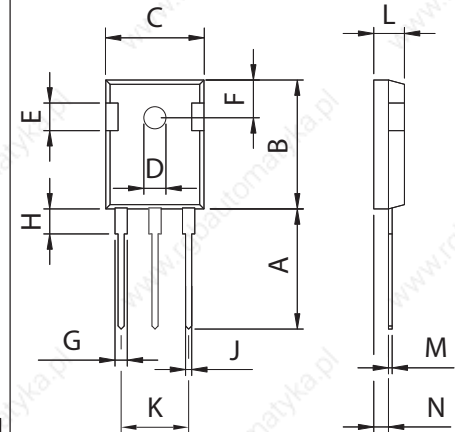

Dim.	Millimeter		Inches	
	Min.	Max.	Min.	Max.
A	19.81	20.32	0.780	0.800
B	20.80	21.46	0.819	0.845
C	15.75	16.26	0.610	0.640
D	3.55	3.65	0.140	0.144
E	4.32	5.49	0.170	0.216
F	5.4	6.2	0.212	0.244
G	1.65	2.13	0.065	0.084
H	-	4.5	-	0.177
J	1.0	1.4	0.040	0.055
K	10.8	11.0	0.426	0.433
L	4.7	5.3	0.185	0.209
M	0.4	0.8	0.016	0.031
N	1.5	2.49	0.087	0.102

X014b TO-247 AD

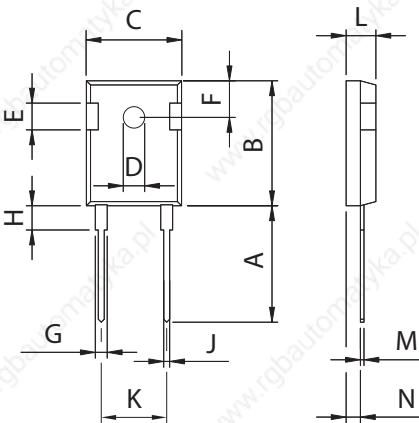

Dim.	Millimeter		Inches	
	Min.	Max.	Min.	Max.
A	19.81	20.32	0.780	0.800
B	20.80	21.46	0.819	0.845
C	15.75	16.26	0.610	0.640
D	3.55	3.65	0.140	0.144
E	4.32	5.49	0.170	0.216
F	5.4	6.2	0.212	0.244
G	1.65	2.13	0.065	0.084
H	-	4.5	-	0.177
J	1.0	1.4	0.040	0.055
K	10.8	11.0	0.426	0.433
L	4.7	5.3	0.185	0.209
M	0.4	0.8	0.016	0.031
N	1.5	2.49	0.087	0.102

X015 PLUS247™

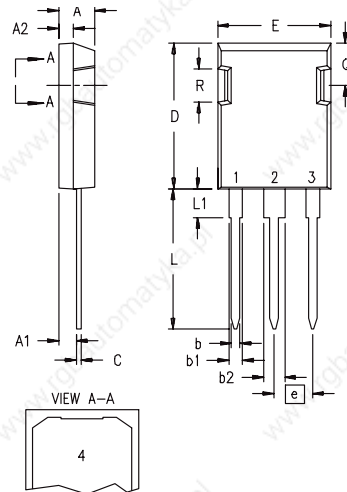

Dim.	Millimeter		Inches	
	Min.	Max.	Min.	Max.
A	4.83	5.21	.190	.205
A ₁	2.29	2.54	.090	.100
A ₂	1.91	2.16	.075	.085
b	1.14	1.40	.045	.055
b ₁	1.91	2.13	.075	.084
b ₂	2.92	3.12	.115	.123
C	0.61	0.80	.024	.031
D	20.80	21.34	.819	.840
E	15.75	16.13	.620	.635
e	5.45 BSC		.215 BSC	
L	19.81	20.32	.780	.800
L1	3.81	4.32	.150	.170
Q	5.59	6.20	.220	.244
R	4.32	4.83	.170	.190

X016a ISOPLUS247

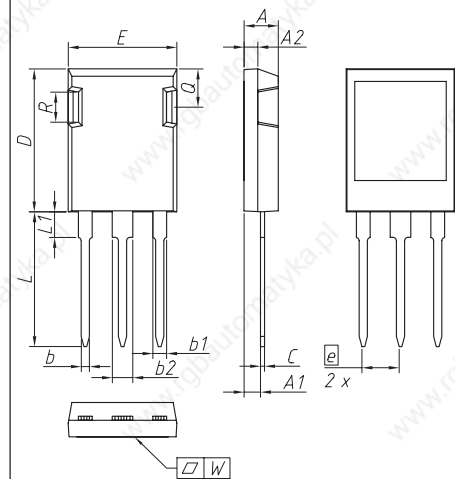

DIM.	MILLIMETER		INCHES	
	MIN	MAX	MIN	MAX
A	4.83	5.21	0.190	0.205
A1	2.29	2.54	0.090	0.100
A2	1.91	2.16	0.075	0.085
b	1.14	1.40	0.045	0.055
b1	1.91	2.15	0.075	0.085
b2	2.92	3.20	0.115	0.126
C	0.61	0.83	0.024	0.033
D	20.80	21.34	0.819	0.840
E	15.75	16.13	0.620	0.635
e	5.45 BSC		.215 BSC	
L	19.81	20.60	0.780	0.811
L1	3.81	4.38	0.150	0.172
Q	5.59	6.20	0.220	0.244
R	4.32	4.85	0.170	0.191
W*	-	0.10	-	0.004

* convex bow of substrate is typ. < 0.04 mm over plastic surface level of device bottom side

Dimensions in mm and inches (1 mm = 0.0394")

X016b ISOPLUS247

NOTE: 1. This drawing will meet all dimensions requirement of JEDEC outline TO-247AD except screw hole.
2. Leads terminals are Pb-free solder plated.
3. Bottom heatsink (4) is pre-Ni plated and electrically isolated 2.500V from pin 1, 2, and 3.

SYM	INCHES		MILLIMETERS	
	MIN	MAX	MIN	MAX
A	.190	.205	4.83	5.21
A1	.090	.100	2.29	2.54
A2	.075	.085	1.91	2.16
b	.045	.055	1.14	1.40
b1	.075	.084	1.91	2.13
b2	.115	.123	2.92	3.12
c	.024	.031	0.61	0.80
D	.819	.840	20.80	21.34
E	.620	.635	15.75	16.13
e	.430	BSC	10.92	BSC
L	.780	.800	19.81	20.32
L1	.150	.170	3.81	4.32
L2	0	.100	0	2.54
Q	.220	.244	5.59	6.20
R	.170	.190	4.32	4.83
S	.520	.540	13.21	13.72
T	.620	.640	15.75	16.26
U	.065	.080	1.65	2.03

X017a TO-3P

All metal area are tin plated.

- 1 - GATE
- 2 - DRAIN (COLLECTOR)
- 3 - SOURCE (EMITTER)
- 4 - DRAIN (COLLECTOR)

SYM	INCHES		MILLIMETERS	
	MIN	MAX	MIN	MAX
A	.185	.193	4.70	4.90
A1	.051	.059	1.30	1.50
A2	.057	.065	1.45	1.65
b	.035	.045	0.90	1.15
b2	.075	.087	1.90	2.20
b4	.114	.126	2.90	3.20
c	.022	.031	0.55	0.80
D	.780	.791	19.80	20.10
D1	.665	.677	16.90	17.20
E	.610	.622	15.50	15.80
E1	.531	.539	13.50	13.70
e	.215	BSC	5.45	BSC
L	.779	.795	19.80	20.20
L1	.134	.142	3.40	3.60
ØP	.126	.134	3.20	3.40
ØP1	.272	.280	6.90	7.10
S	.193	.201	4.90	5.10

X017b TO-3P

- 1 - GATE
- 2 - DRAIN (COLLECTOR)
- 3 - SOURCE (EMITTER)
- 4 - DRAIN (COLLECTOR) connected to Pin 2.

SYM	INCHES		MILLIMETERS	
	MIN	MAX	MIN	MAX
A	.185	.193	4.70	4.90
A1	.051	.059	1.30	1.50
A2	.057	.065	1.45	1.65
b	.035	.045	0.90	1.15
b2	.075	.087	1.90	2.20
b4	.114	.126	2.90	3.20
c	.022	.031	0.55	0.80
D	.780	.799	19.80	20.30
D1	.665	.677	16.90	17.20
E	.610	.622	15.50	15.80
E1	.531	.539	13.50	13.70
e	.215	BSC	5.45	BSC
L	.779	.795	19.80	20.20
L1	.134	.142	3.40	3.60
L2	0	.055	0	1.40
ØP	.126	.134	3.20	3.40
ØP1	.272	.280	6.90	7.10
S	.193	.201	4.90	5.10

X018 TO-268 I³PAK

All metal area are solder plated

- 1 - gate
- 2 - drain (collector)
- 3 - source (emitter)
- 4 - drain (collector)

Dim.	Inches		Millimeters	
	Min	Max	Min	Max
A	.193	.201	4.90	5.10
A1	.106	.114	2.70	2.90
b	.045	.057	1.15	1.45
b2	.075	.083	1.90	2.10
C	.016	.026	.040	.065
C2	.057	.063	1.45	1.60
D	.543	.551	13.80	14.00
D1	.488	.500	12.40	12.70
E	.624	.632	15.85	16.05
E1	.524	.535	13.30	13.60
e	.215	BSC	5.45	BSC
H	1.365	1.395	34.67	35.43
L	.780	.800	19.81	20.32
L1	.079	.091	2.00	2.30
L2	.039	.045	1.00	1.15

X019 TO-268 AA (D³PAK)

Dim.	Millimeter		Inches	
	Min.	Max.	Min.	Max.
A	4.9	5.1	.193	.201
A ₁	2.7	2.9	.106	.114
A ₂	.02	.25	.001	.010
b	1.15	1.45	.045	.057
b ₂	1.9	2.1	.75	.83
C	.4	.65	.016	.026
D	13.80	14.00	.543	.551
E	15.85	16.05	.624	.632
E ₁	13.3	13.6	.524	.535
e	5.45 BSC			
H	18.70	19.10	.736	.752
L	2.40	2.70	.094	.106
L1	1.20	1.40	.047	.055
L2	1.00	1.15	.039	.045
L3	0.25 BSC		.010 BSC	
L4	3.80	4.10	.150	.161

X020 TO-264 AA

Back side Rückseite

Dim.	Millimeter		Inches	
	Min.	Max.	Min.	Max.
A	4.82	5.13	.190	.202
A1	2.54	2.89	.100	.114
A2	2.00	2.10	.079	.083
b	1.12	1.42	.044	.056
b1	2.39	2.69	.094	.106
b2	2.90	3.09	.114	.122
c	0.53	0.83	.021	.033
D	25.91	26.16	1.020	1.030
E	19.81	19.96	.780	.786
e	5.46 BSC		.215 BSC	
J	0.00	0.25	.000	.010
K	0.00	0.25	.000	.010
L	20.32	20.83	.800	.820
L1	2.29	2.59	.090	.102
P	3.17	3.66	.125	.144
Q	6.07	6.27	.239	.247
Q1	8.38	8.69	.330	.342
R	3.81	4.32	.150	.170
R1	1.78	2.29	.070	.090
S	6.04	6.30	.238	.248
T	1.57	1.83	.062	.072

Dimensions in mm and inches (1 mm = 0.0394")

X021 PLUS264

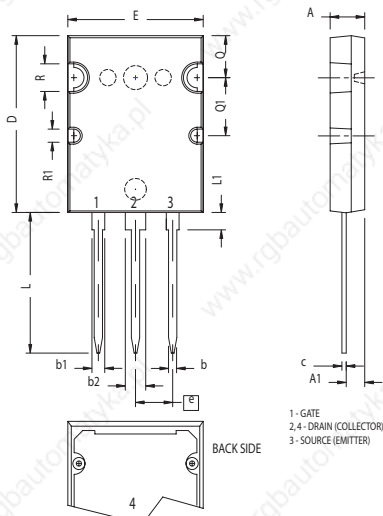

SYM	INCHES		MILLIMETERS	
	MIN	MAX	MIN	MAX
A	.185	.209	4.70	5.31
A1	.102	.118	2.59	3.00
b	.037	.055	0.94	1.40
b1	.087	.102	2.21	2.59
b2	.110	.126	2.79	3.20
c	.017	.029	0.43	0.74
D	1.007	1.047	25.58	26.59
E	.760	.799	19.30	20.29
e	.215 BSC		5.46 BSC	
L	.779	.842	19.79	21.39
L1	.087	.102	2.21	2.59
Q	.240	.256	6.10	6.50
Q1	.330	.346	8.38	8.79
∅R	.155	.187	3.94	4.75
∅R1	.085	.093	2.16	2.36

X022 ISOPLUS264

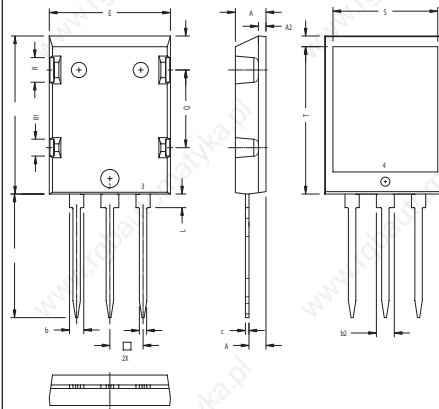

SYM	INCHES		MILLIMETER	
	MIN	MAX	MIN	MAX
A1	.102	.118	2.59	3.00
A2	.046	.055	1.17	1.40
b	.045	.055	1.14	1.40
b1	.087	.102	2.21	2.59
b2	.100	.110	2.54	2.79
c	.020	.029	0.51	0.74
D	1.020	1.040	25.91	26.42
E	.770	.799	19.56	20.29
e	.150 BSC		3.81 BSC	
L	.780	.820	19.81	20.83
L1	.080	.102	2.03	2.59
Q	.210	.235	5.33	5.97
Q1	.490	.513	12.45	13.03
R	.150	.180	3.81	4.57
R1	.100	.130	2.54	3.30
S	.668	.690	16.97	17.53
T	.801	.821	20.34	20.85
U	.065	.080	1.65	2.03

X022c ISOPLUS264 (3HV)

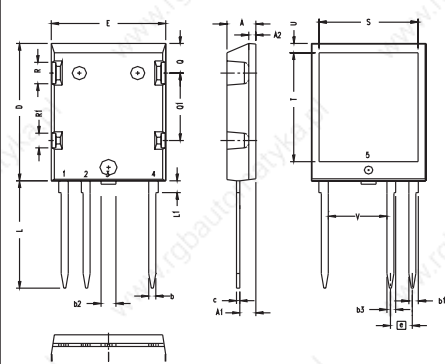

SYM	INCHES		MILLIMETERS	
	MIN	MAX	MIN	MAX
A	.190	.205	4.83	5.21
A1	.102	.118	2.59	3.00
A2	.046	.055	1.17	1.40
b	.045	.055	1.14	1.40
b1	.063	.072	1.60	1.83
b2	.100	.110	2.54	2.79
b3	.058	.068	1.47	1.73
c	.020	.029	0.51	0.74
D	1.020	1.040	25.91	26.42
E	.770	.799	19.56	20.29
e	.150 BSC		3.81 BSC	
L	.780	.820	19.81	20.83
L1	.080	.102	2.03	2.59
O	.210	.235	5.33	5.97
Q1	.490	.513	12.45	13.03
R	.150	.180	3.81	4.57
R1	.100	.130	2.54	3.30
S	.668	.690	16.97	17.53
T	.801	.821	20.34	20.85
U	.065	.080	1.65	2.03
V	.398	.406	10.11	10.31

X023 ISO264

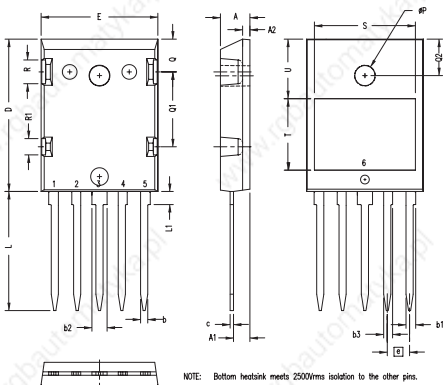

SYM	INCHES		MILLIMETERS	
	MIN	MAX	MIN	MAX
A	.190	.205	4.83	5.21
A1	.102	.118	2.59	3.00
A2	.046	.055	1.17	1.40
b	.045	.055	1.14	1.40
b1	.063	.072	1.60	1.83
b2	.100	.110	2.54	2.79
b3	.058	.068	1.47	1.73
c	.020	.029	0.51	0.74
D	1.020	1.040	25.91	26.42
E	.770	.799	19.56	20.29
e	.150 BSC		3.81 BSC	
L	.780	.820	19.81	20.83
L1	.080	.102	2.03	2.59
P	.130	.145	3.30	3.68
O	.210	.235	5.33	5.97
Q1	.490	.513	12.45	13.03
Q2	.235	.255	5.96	6.48
R	.150	.180	3.81	4.57
R1	.100	.130	2.54	3.30
S	.668	.690	16.97	17.53
T	.470	.490	11.94	12.45
U	.390	.410	9.91	10.41

X024a ISOPLUS i4-Pac™

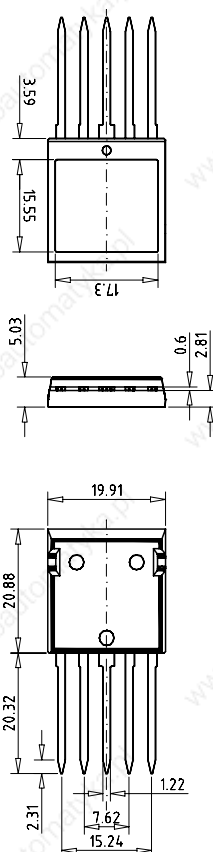

X024b ISOPLUS i4-Pac™

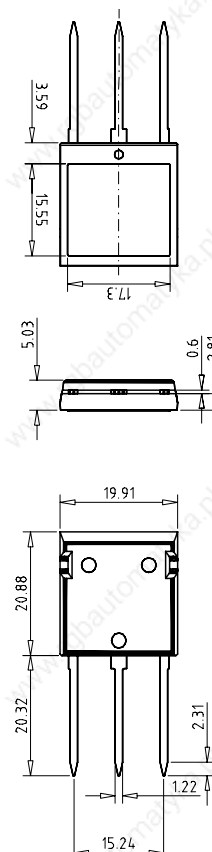

Dimensions in mm and inches (1 mm = 0.0394")

X024c ISOPLUS i4-Pac™

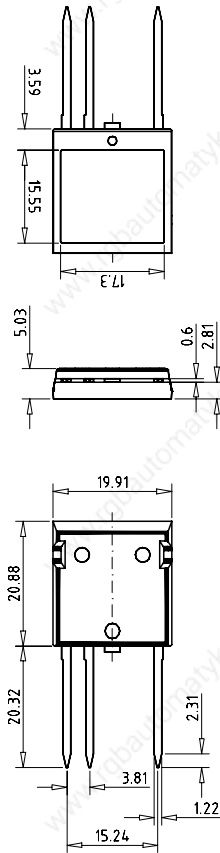

X025 GBFP

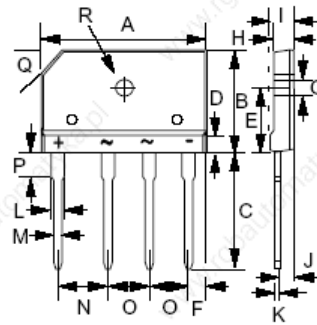

DIM.	MIN.	MAX.
A	29.70	30.30
B	19.70	20.30
C	17.0	18.0
D	4.70	4.90
E	10.80	11.20
F	2.30	2.70
G	3.10	3.40
H	3.40	3.80
I	4.40	4.80
J	2.50	2.90
K	0.60	0.80
L	2.00	2.40
M	0.90	1.10
N	9.80	10.20
O	7.30	7.70
P	3.80	4.20
Q	(3.0) x 45°	
R	3.10 ϕ	3.40 ϕ

All Dimensions in millimeter

X026a ISOPLUS-DIL (SL)

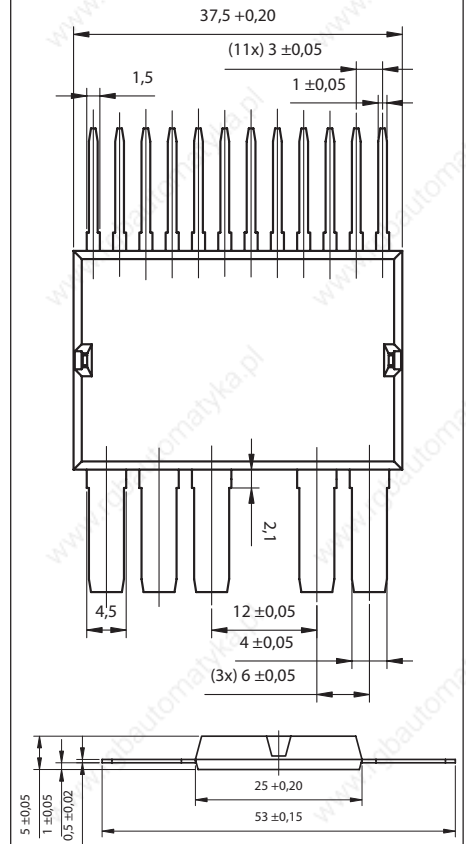

X026b ISOPLUS-DIL (BL)

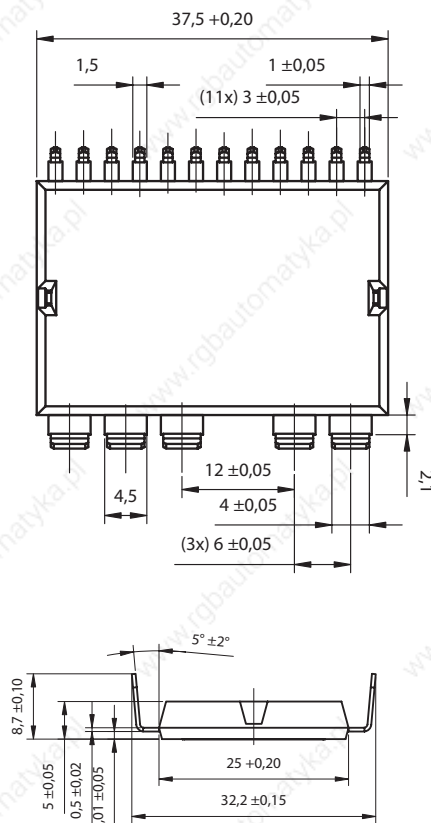

X026c ISOPLUS-DIL (SMD)

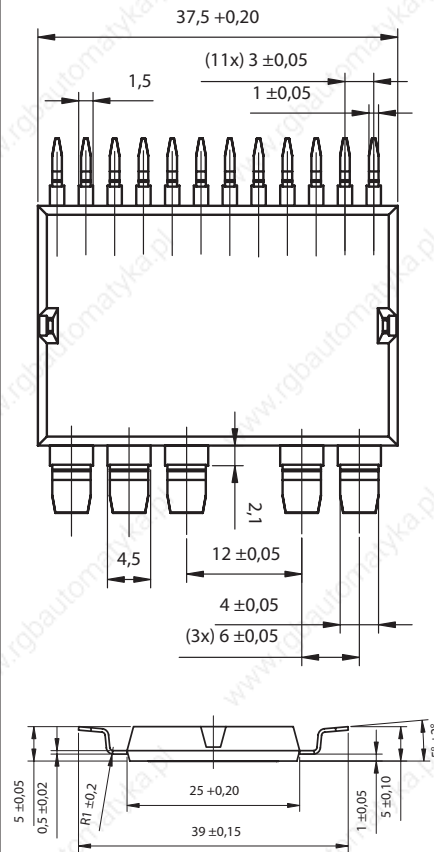

X027a SOT-227 B miniBLOC
X027b SOT-227 UI miniBLOC

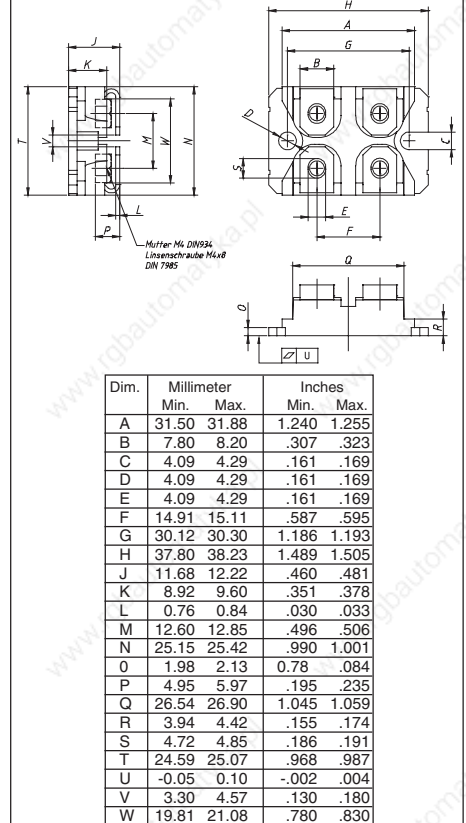

Dimensions in mm and inches (1 mm = 0.0394")

X028 ISOPLUS227™

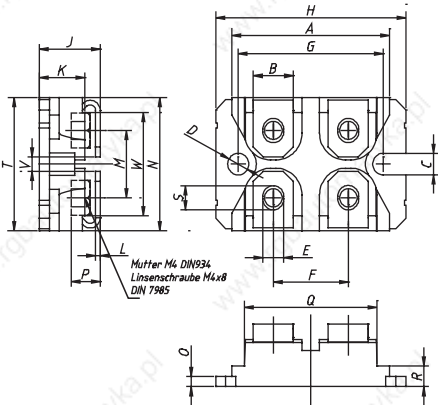

SYM	INCHES		MILLIMETERS	
	MIN	MAX	MIN	MAX
A	1.240	1.270	31.50	32.26
B	.310	.330	7.87	8.38
C	.155	.165	3.94	4.19
D	.155	.165	3.94	4.19
D1	.150	.157	3.81	3.98
E	.160	.168	4.06	4.27
F	.587	.595	14.91	15.11
G	1.186	1.193	30.12	30.30
H	1.489	1.505	37.80	38.23
J	.465	.481	11.81	12.22
K	.370	.380	9.40	9.65
L	.030	.033	0.76	0.84
M	.496	.506	12.60	12.85
N	.990	1.001	25.15	25.42
O	.100	.105	2.54	2.67
P	.195	.205	4.95	5.19
Q	1.045	1.059	26.54	26.90
R	.160	.170	4.06	4.32
S	.186	.191	4.72	4.85
T	.968	.987	24.59	25.07
U	-.001	.002	-0.03	0.05
V	.130	.160	3.30	4.06
W	.780	.830	19.81	21.08
X	.770	.810	19.56	20.57
Y	.680	.720	17.27	18.29
Z	.885	.892	22.48	22.66

X100 Slim-PAC

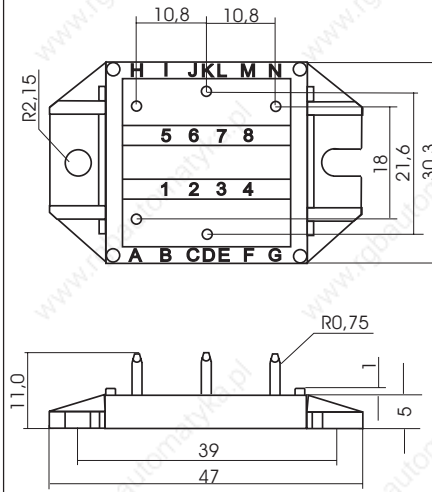

See data sheet for pin arrangement

X101 ECO-PAC1

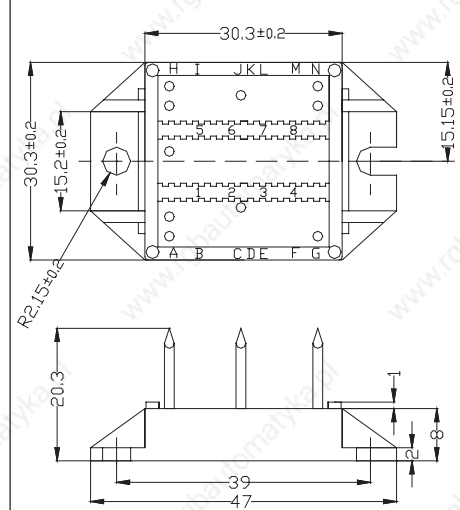

See data sheet for pin arrangement

X102 ECO-PAC2

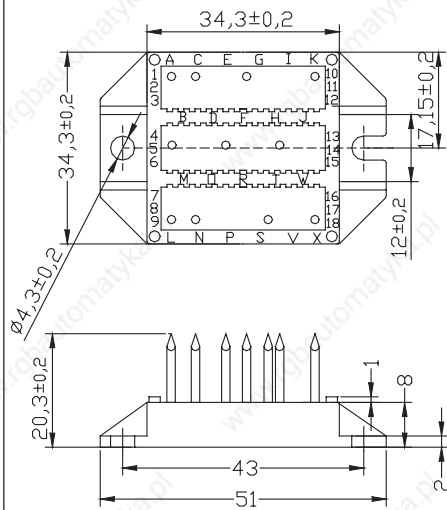

See data sheet for pin arrangement

X103 V1-A-Pack

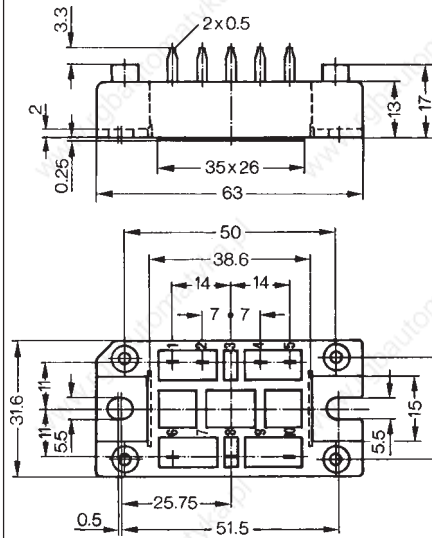

See data sheet for pin arrangement

X104 V2-Pack

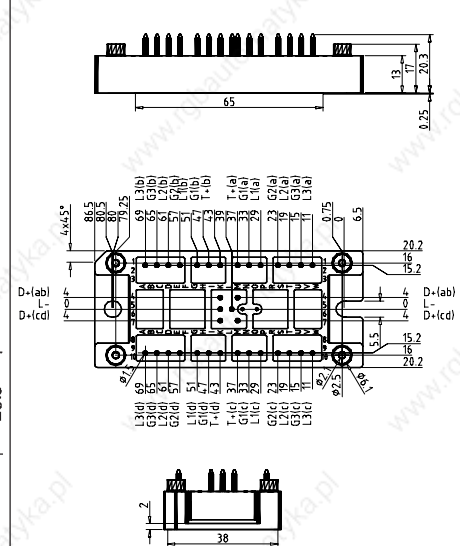

See data sheet for pin arrangement

Dimensions in mm and inches (1 mm = 0.0394")

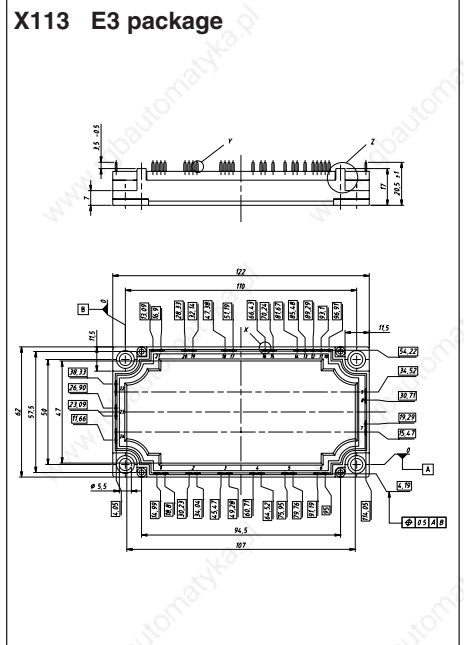
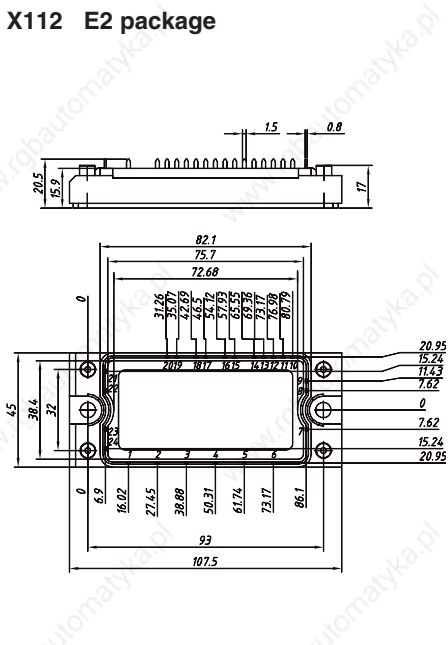
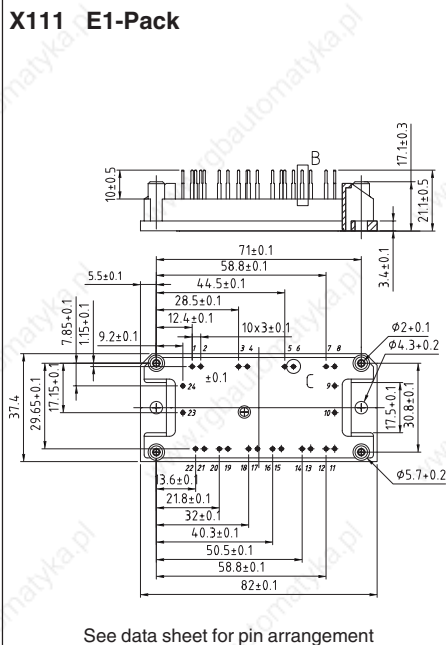
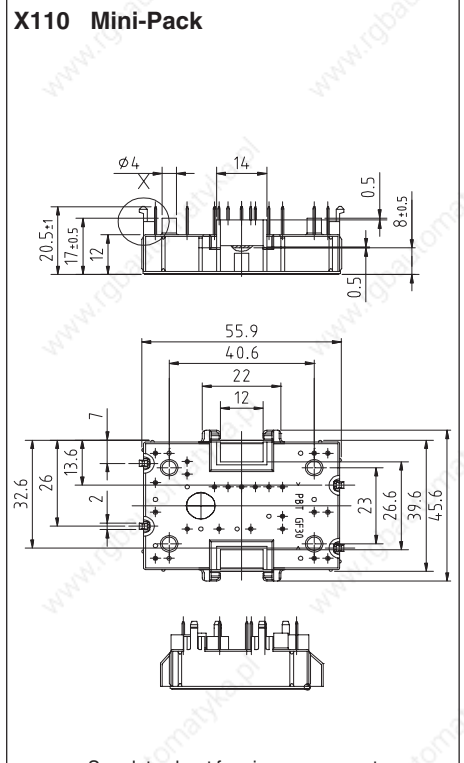
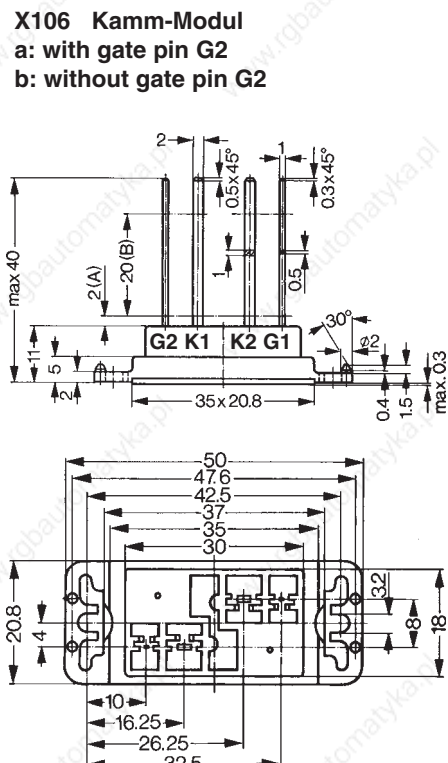
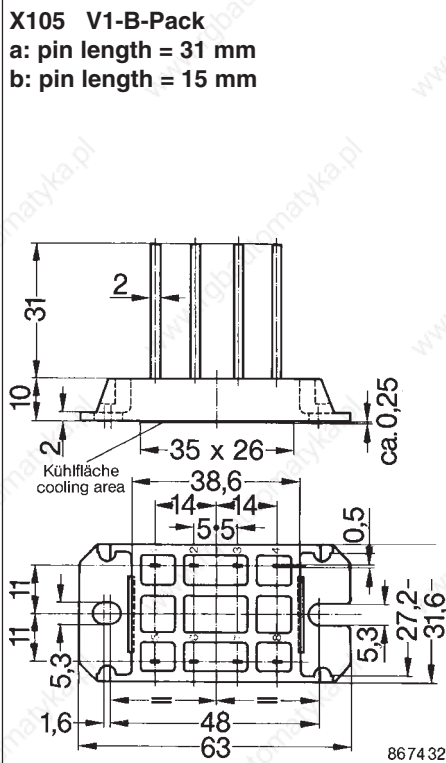

Dimensions in mm and inches (1 mm = 0.0394")

X114 E9-Pack

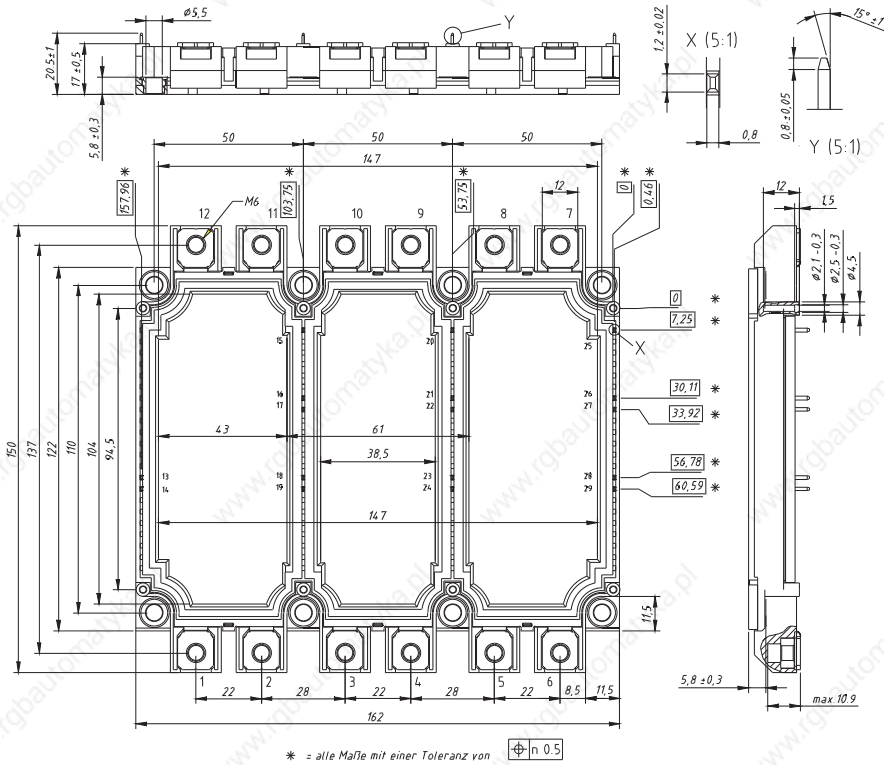

X115 FO-A

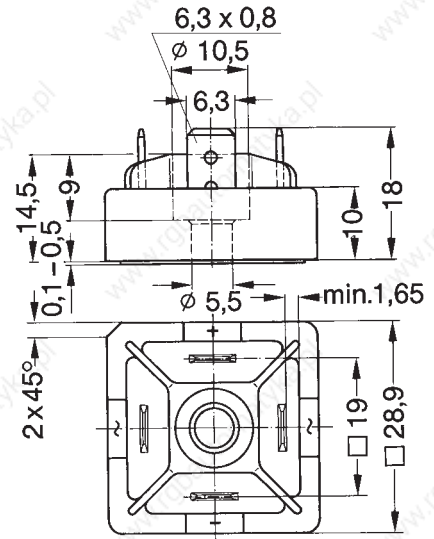

X116a FO-B-A

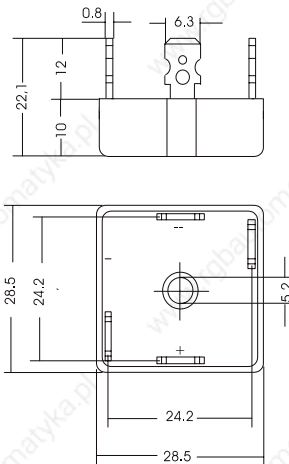

X116b FO-B-B

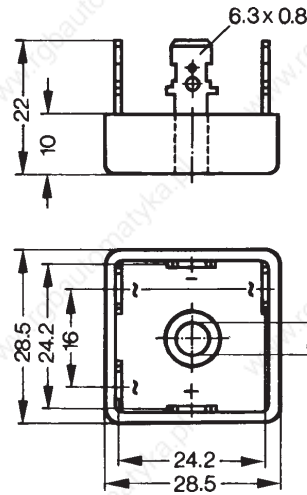

X117a FO-F-A

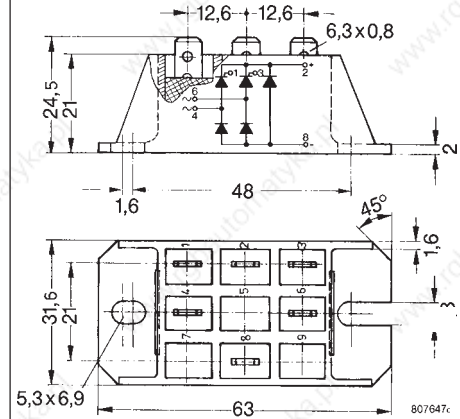

Dimensions in mm and inches (1 mm = 0.0394")

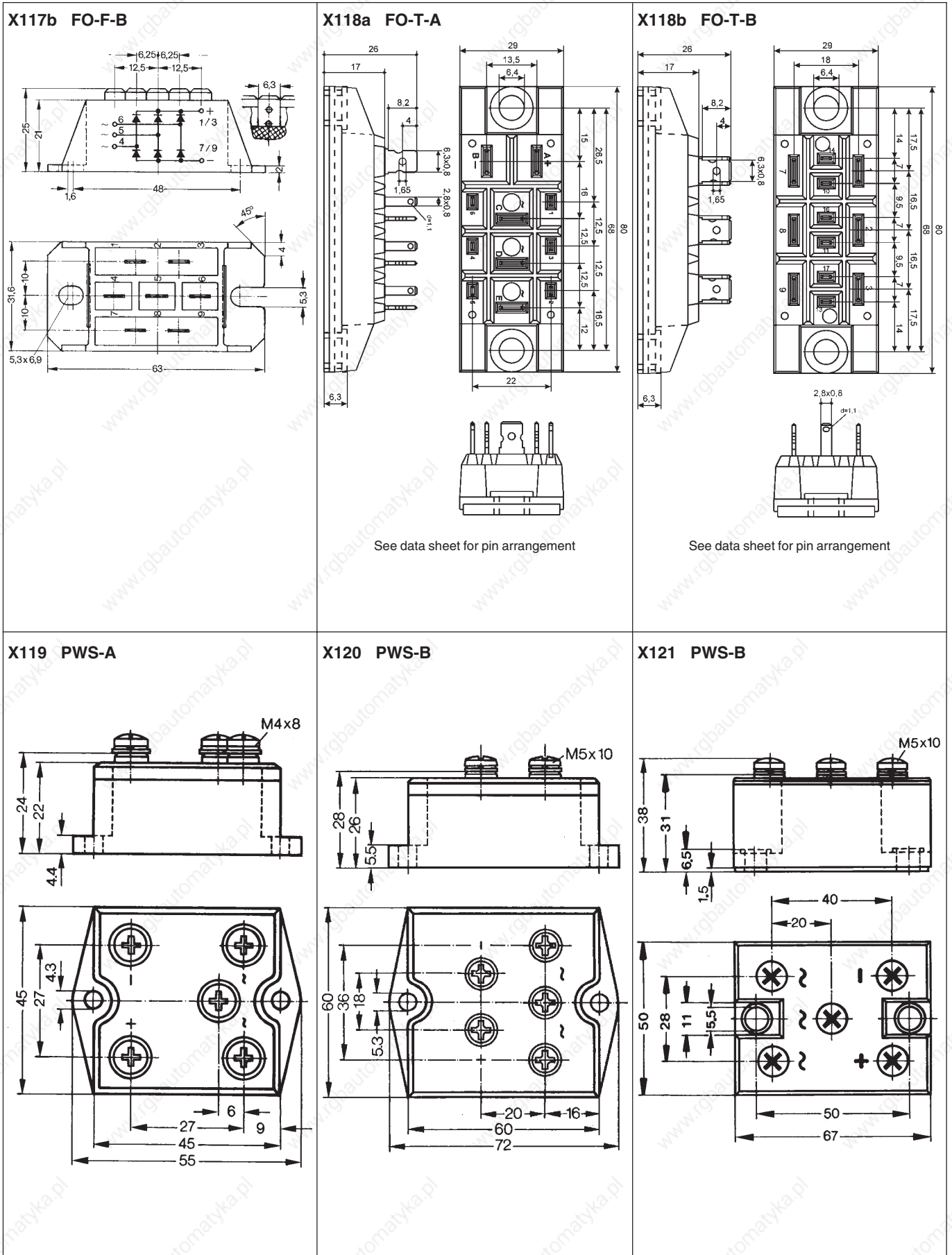

Dimensions in mm and inches (1 mm = 0.0394")

X122 PWS-D

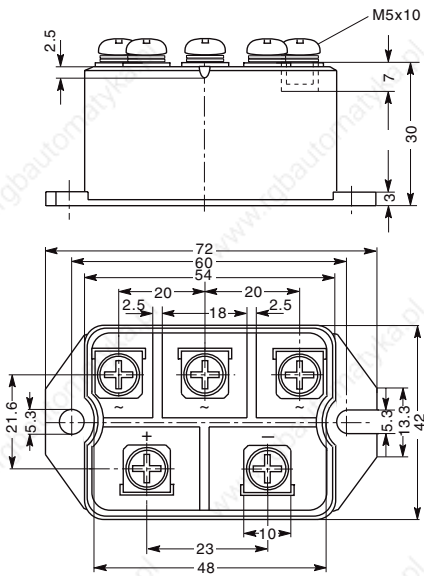

X123a PWS-E-1

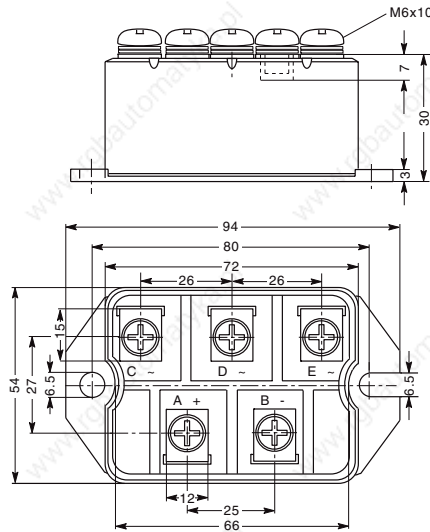

X123b PWS-E-2

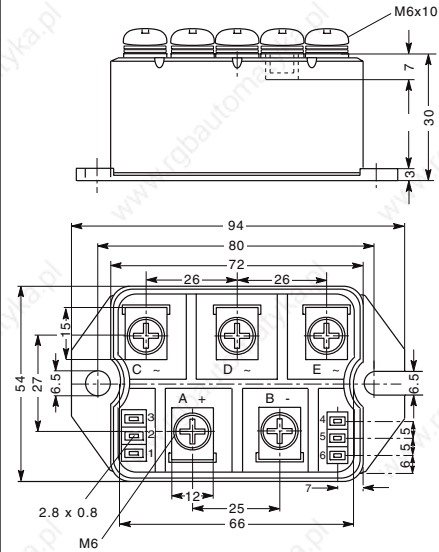

X124 PWS-F

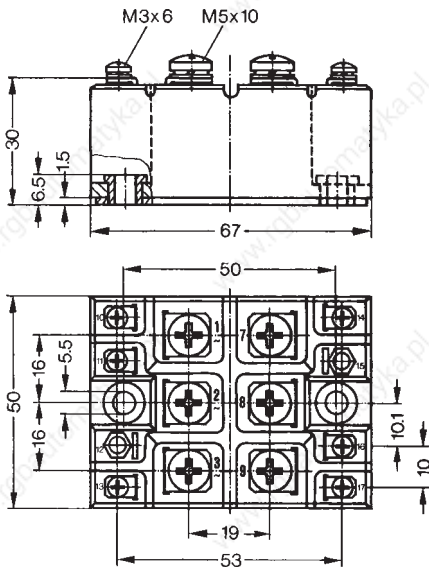

X125 TO-240 AA

- a: (+ Kelvin contact (MCC))
- b: (+ Kelvin contact, w/o pin 6 & 7 (MCD))
- c: (w/o Kelvin contact 4 & 7 (MCC))
- d: (w/o Kelvin contact 4, 7 & pin 6 (MCD))
- e: (w/o pin 4, 5, 6 & 7 (MDD))

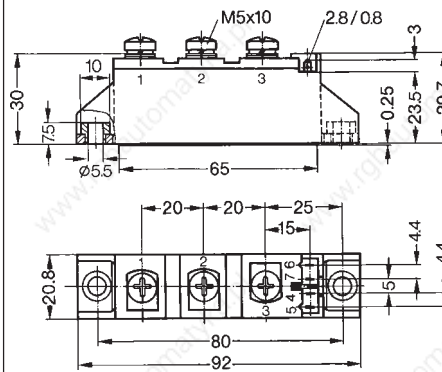

See data sheet for pin arrangement

X126 Y4-M6

- a: (+ Kelvin contact (MCC))
- b: (+ Kelvin contact, w/o pin 6 & 7 (MCD))
- c: (w/o pin 4, 5, 6 & 7 (MDD))
- d: (w/o terminal 2 (MEO))

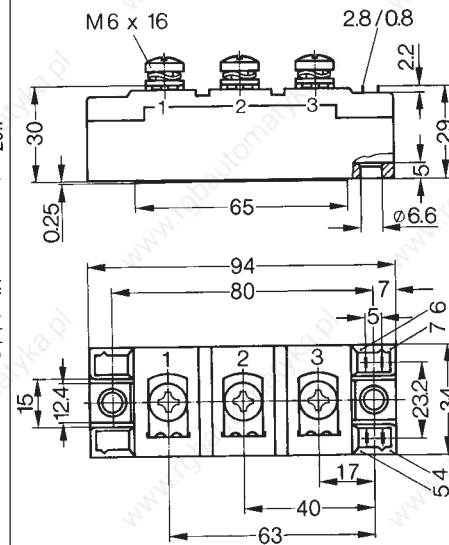

Dimensions in mm and inches (1 mm = 0.0394")

<p>X127 Y4-M5 a: (MII) b: (w/o pin 6 & 7 (MID)) c: (w/o pin 4 & 5 (MDI))</p>	<p>X128 Y3-DCB a: (MII) b: (w/o pin 8 & 9 (MID)) c: (w/o pin 10 & 11 (MDI)) d: (w/o terminal 3 (VMO))</p>	<p>X129 Y2-DCB a: (+ Kelvin contact (MCC)) b: (+ Kelvin contact, w/o pin 6 & 7 (MCD)) c: (w/o pin 4, 5, 6 & 7 (MDD))</p>
<p>X130 Y3-Li a: (low inductance (VMM, MII)) b: (w/o pin 8 & 9, low inductance (MID)) c: (w/o pin 10 & 11, low inductance (MDI)) d: (w/o terminal 1, low inductance (VMO))</p>	<p>X131 Y1-CU a: (+ Kelvin contact (MCC)) b: (+ Kelvin contact, w/o pin 6 & 7 (MCD)) c: (w/o pin 4, 5, 6 & 7 (MDD))</p>	<p>X132 Y1-2-CU a: (+ Kelvin contact (MCO)) b: (w/o pin 4 & 5 (MDO))</p>

Dimensions in mm and inches (1 mm = 0.0394")

X133 Y1-wc (+ water-cooler, HVL)

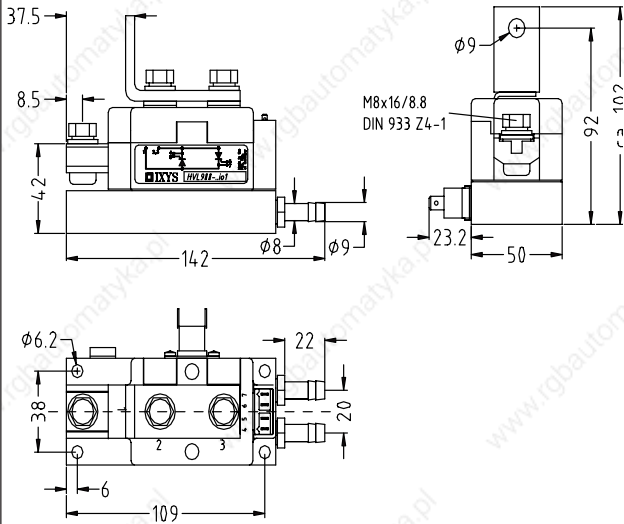

X134 E10-Pack

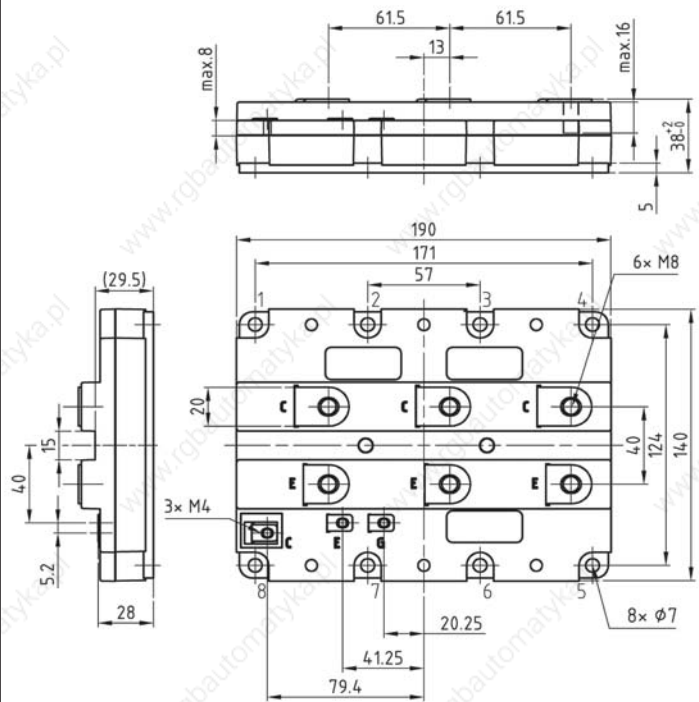

X135 E11-Pack

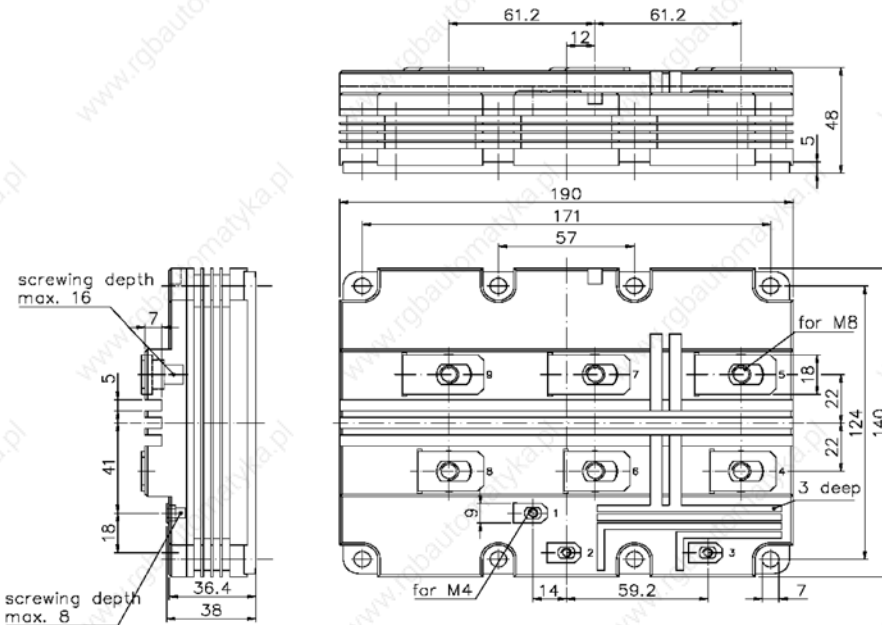

Dimensions in mm and inches (1 mm = 0.0394")

X136a WC-500

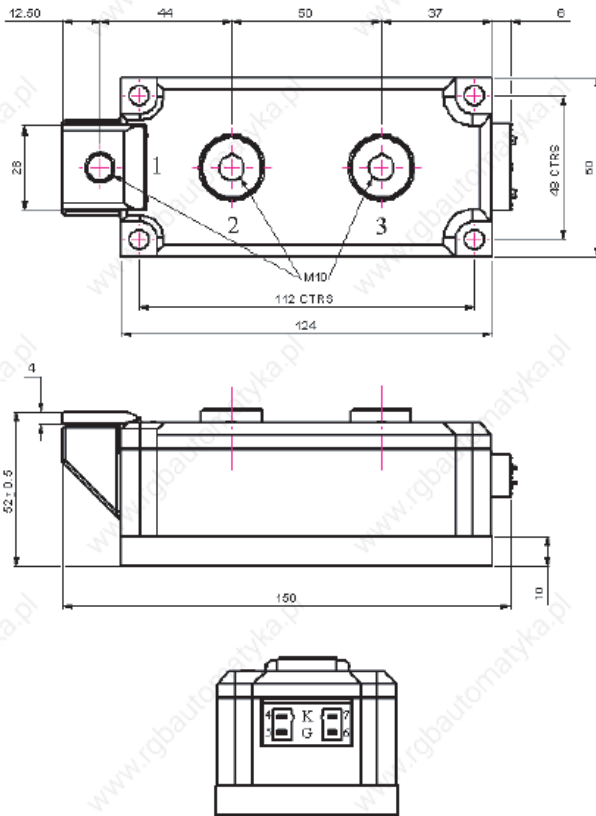

X136b WC-500 wc

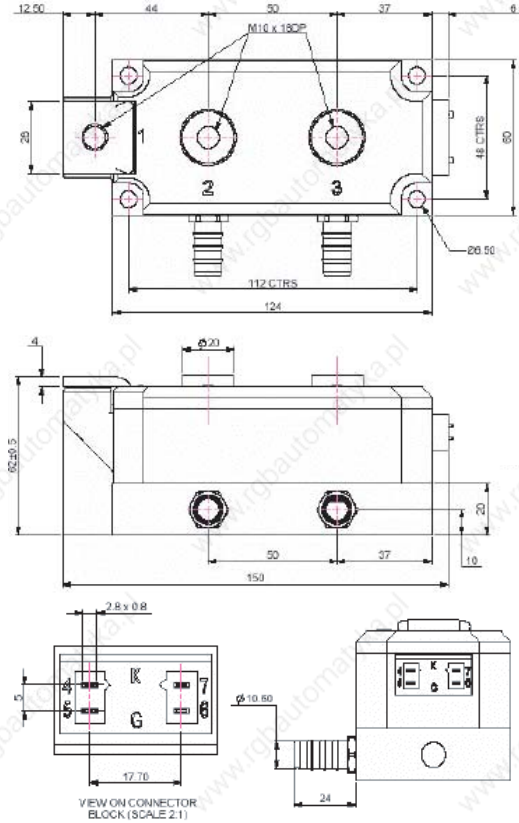

X200 Metal-can

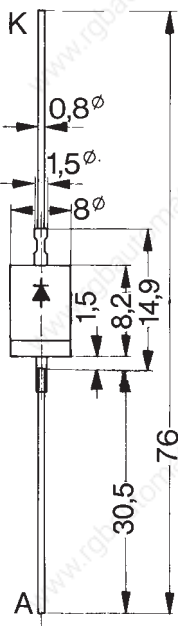

X201 FP-Case (oilproof)

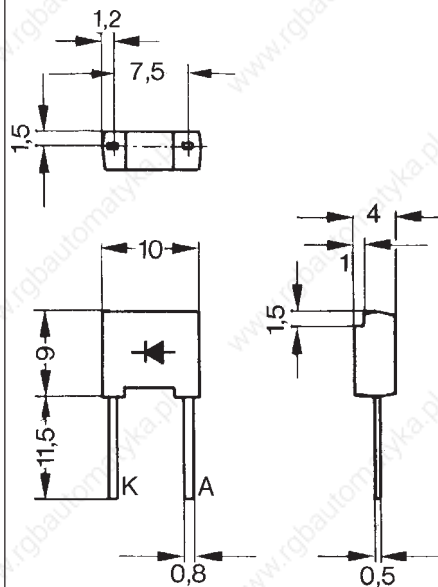

X202 BOD-Package

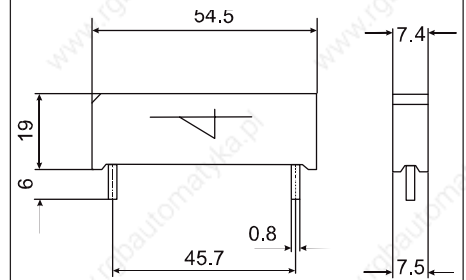

Dimensions in mm and inches (1 mm = 0.0394")

X203 TO-204 AE

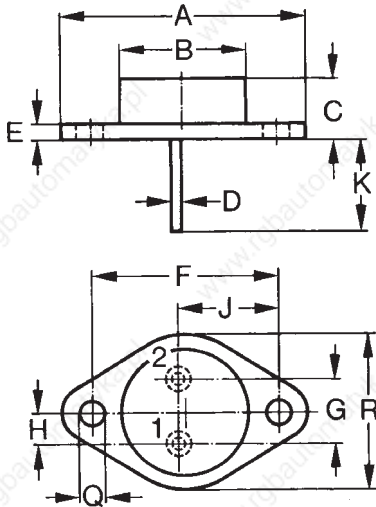

Dim.	Millimeter		Inches	
	Min.	Max.	Min.	Max.
A	38.61	39.12	1.520	1.540
B	-	22.22	-	0.875
C	6.40	11.40	0.252	0.449
D	1.45	1.60	0.057	0.063
E	1.52	3.43	0.060	0.135
F	30.15	BSC	1.187	BSC
G	10.67	11.17	0.420	0.440
H	5.21	5.71	0.205	0.225
J	16.64	17.14	0.655	0.675
K	11.18	12.19	0.440	0.480
Q	3.84	4.19	0.151	0.165
R	25.16	26.66	0.991	1.050

X204 DO-203 AA [M] (DO-4)

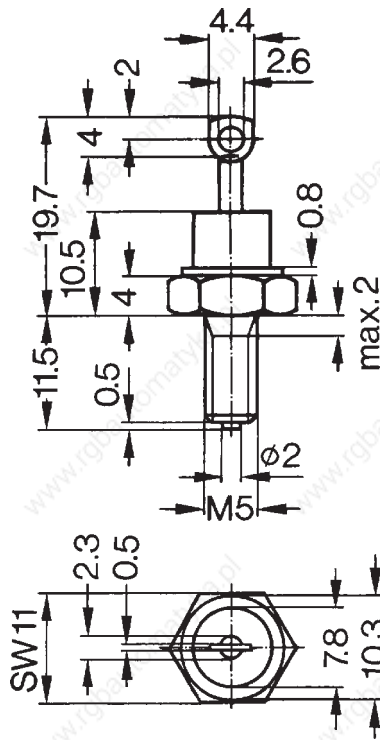

X205 DO-203 AA [UNF] (DO-4)

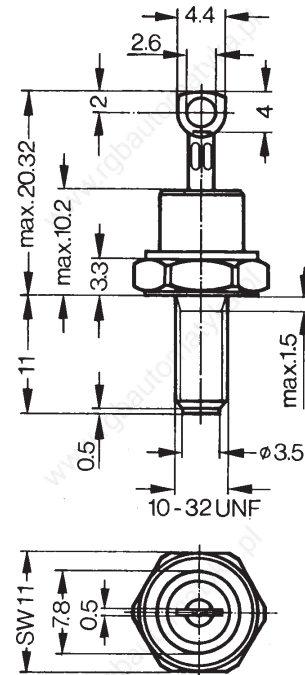

X206a DO-203 AB [UNF] (DO-5)
X206b DO-203 AB [M] (DO-5)

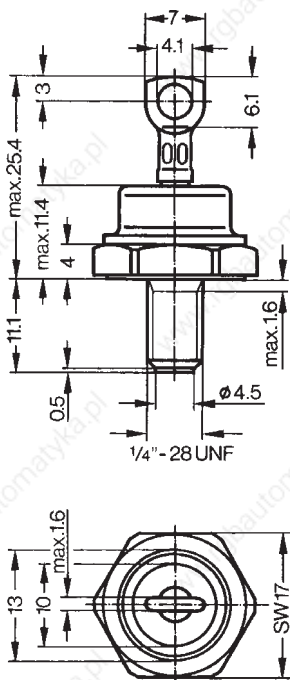

X207 DO-203 AB (DO-5)

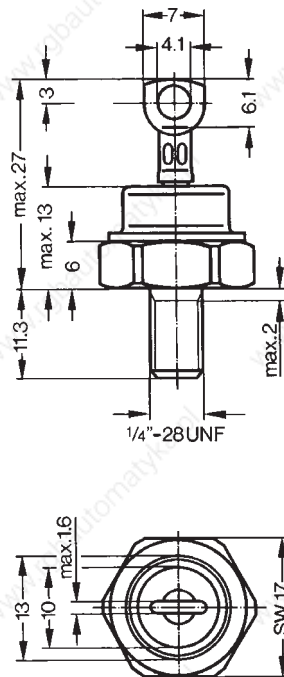

X208 TO-64

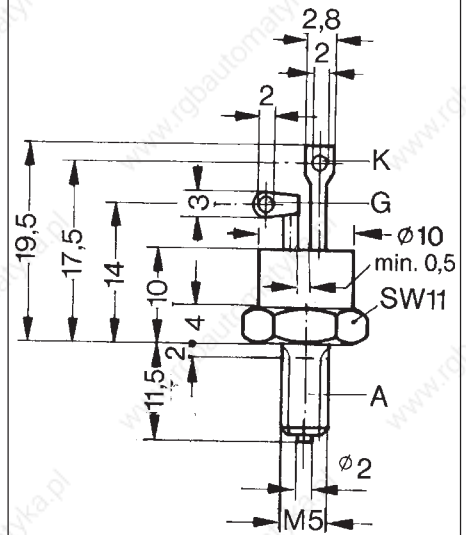

Dimensions in mm and inches (1 mm = 0.0394")

X209 TO-208 AA (TO-48)

86 71 11

X210 TO-208 AC (TO-65)

817543b

X250a-g HTZ

Type	A	B	C
a: HTZ 110	368	48	48
a: HTZ 120	368	48	48
b: HTZ 130	201	32	31
c: HTZ 150	130	32	31
c: HTZ 160	130	32	31
c: HTZ 170	130	32	31
d: HTZ 180	264	32	32
e: HTZ 240	166	27	21
f: HTZ 250	306	65	47
f: HTZ 260	306	65	47
g: HTZ 270	382	64	47
g: HTZ 280	382	64	47

all dimension in mm
other dimensions see datasheet

X251 UGE-single

X252 UGB 1~

UGB 3132 AD
UGB 6124 AG

X253 UGD 3~

UGD 6123 AG
UGD 8124 AG

Type	a	b	c	d	e	f	g	h	i	k
UGB 3132 AD	80	70	57	58.5	260	6	15	15	15	
UGB 6124 AG	135	125	112	58.5	260	11	32.5	25	32.5	
UGB 6123 AG	135	125	112	58.5	260	8	30	18	18	30
UGB 8124 AG	135	125	112	58.5	260	8	30	18	18	30

Dimensions in mm and inches (1 mm = 0.0394")

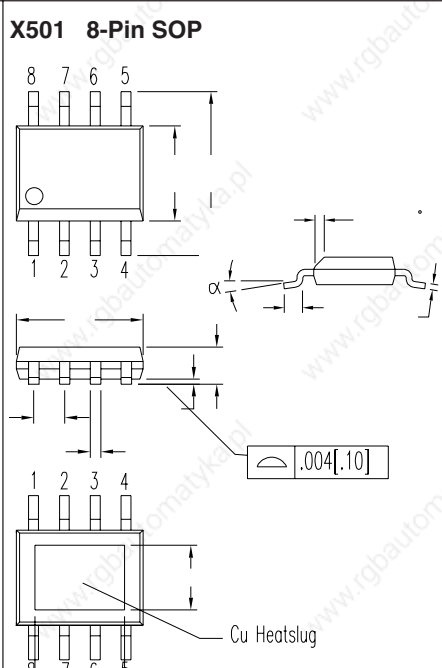
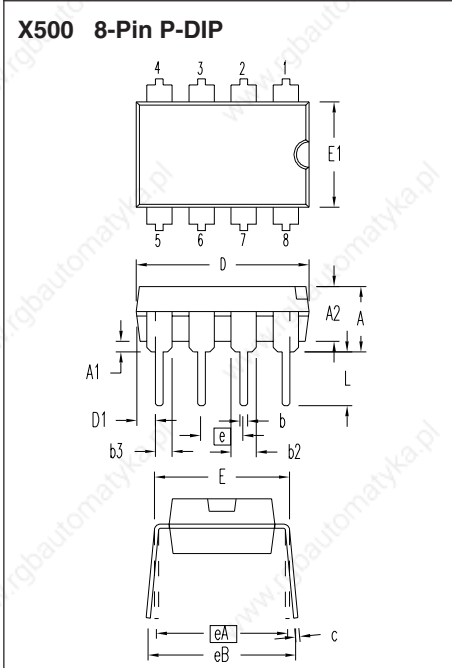
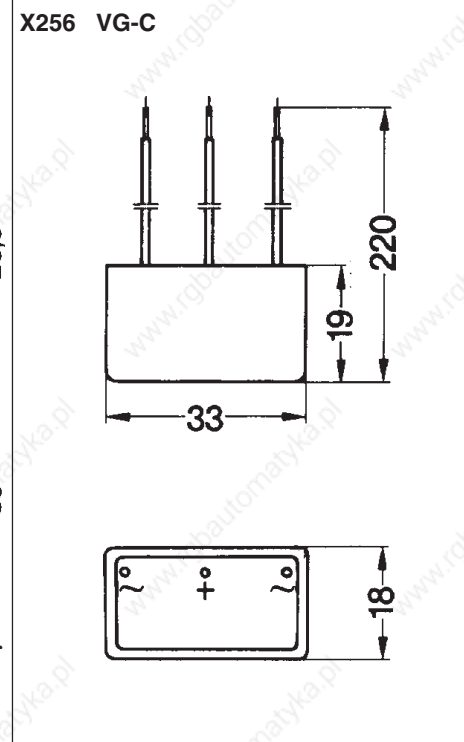
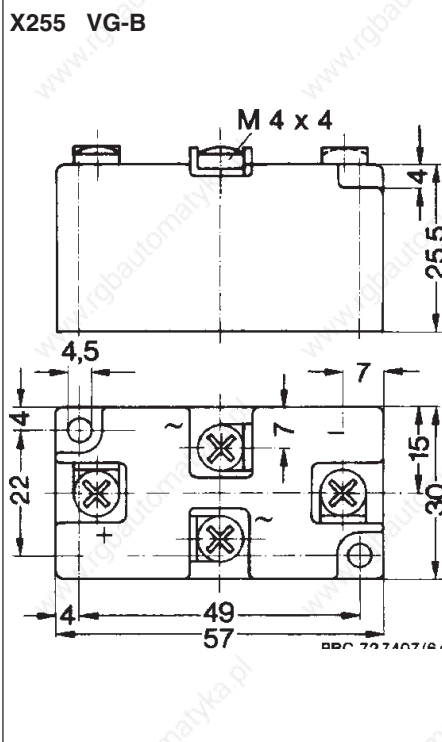
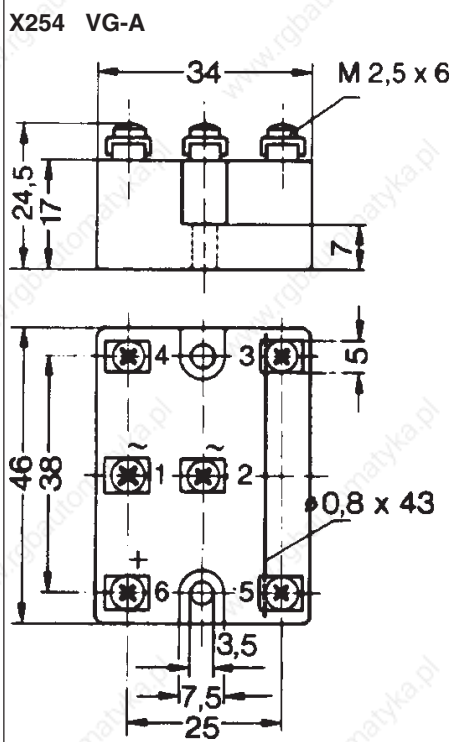

SYM	INCHES		MILLIMETERS	
	MIN	MAX	MIN	MAX
A	.140	.180	3.56	4.57
A1	.015	.040	0.38	1.02
A2	.125	.145	3.18	3.68
b	.015	.020	0.38	0.51
b2	.055	.065	1.40	1.65
b3	.035	.045	0.89	1.14
c	.009	.012	0.23	0.30
D	.355	.400	9.02	10.16
D1	.010	.040	0.25	1.02
E	.300	.325	7.62	8.26
E1	.240	.270	6.10	6.86
e	.100 BSC		2.54 BSC	
eA	.300 BSC		7.62 BSC	
eB	.300	.430	7.62	10.92
L	.120	.140	3.05	3.56

SYM	INCHES		MILLIMETERS	
	MIN	MAX	MIN	MAX
A	.053	.069	1.35	1.75
A1	.004	.010	0.10	0.25
B	.013	.020	0.33	0.51
C	.008	.010	0.19	0.25
D	.189	.197	4.80	5.00
E	.150	.157	3.80	4.00
e	.050 BSC		1.27 BSC	
H	.228	.244	5.80	6.20
h	.010	.020	0.25	0.50
L	.016	.050	0.40	1.27
M	.135	.155	3.43	3.94
N	.095	.115	2.41	2.92
α	0°	8°	0°	8°

Dimensions in mm and inches (1 mm = 0.0394")

X520 14-Pin PDIP

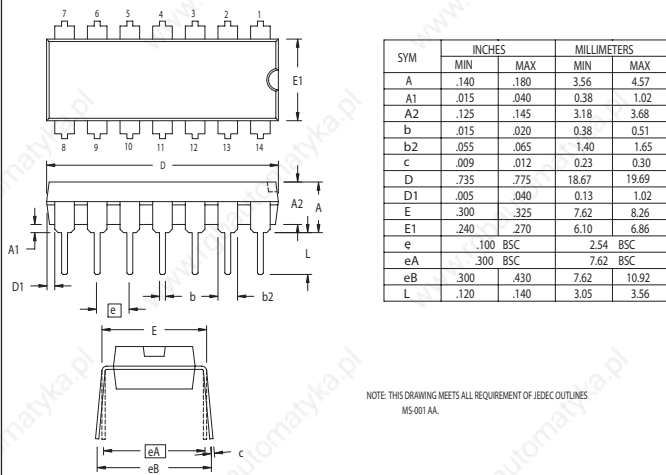

X521 14-Pin SOP

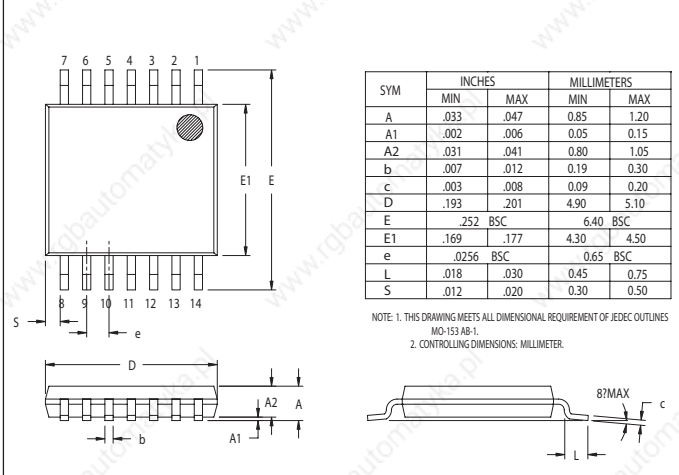

X530 16-Pin PDIP

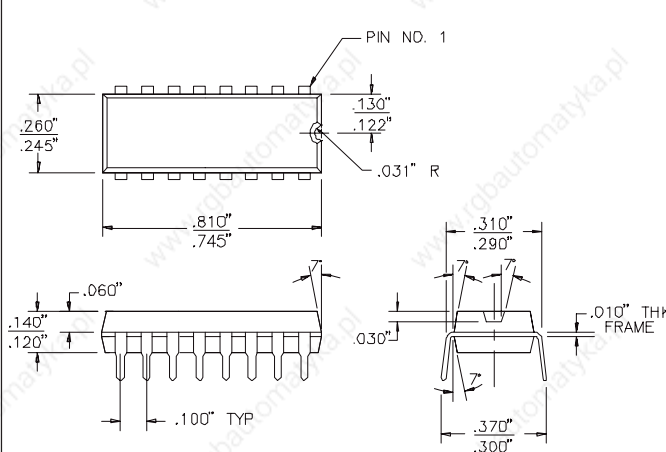

X531 16-Pin SOP

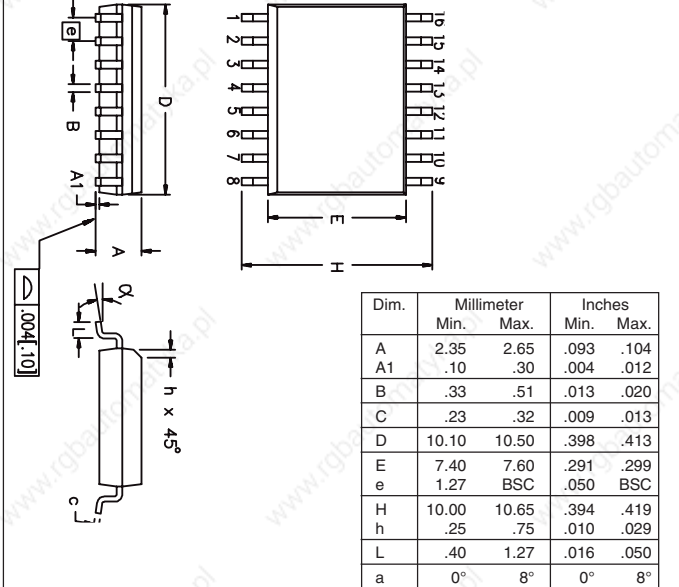

X540 18-Pin PDIP

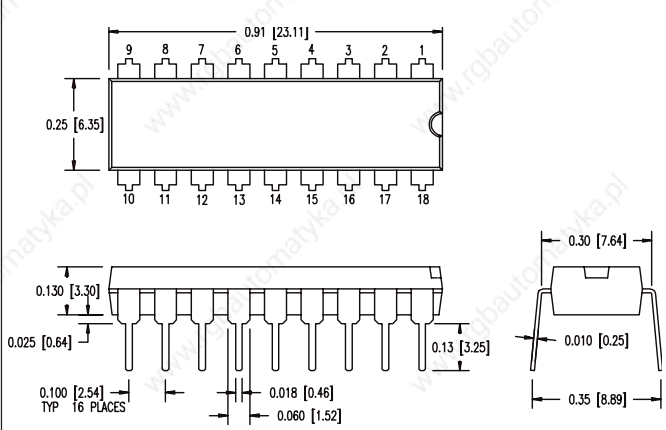

X541 18-Pin SOP



Dimensions in mm and inches (1 mm = 0.0394")

X542 18-Pin SOIC-CT

SYM	INCHES		MILLIMETERS	
	MIN	MAX	MIN	MAX
A	.093	.104	2.35	2.65
A1	.004	.012	.10	.30
B	.013	.020	.33	.51
C	.009	.013	.23	.32
D	.447	.462	11.35	11.73
D1	.310	.350	7.87	8.89
E	.291	.299	7.40	7.60
E1	.140	.180	3.56	4.57
e	.050 BSC		1.27 BSC	
H	.394	.419	10.00	10.65
h	.010	.029	.25	.75
L	.016	.050	.40	1.27
α	0°	8°	0°	8°

NOTE: This drawing will meet all dimensions requirement of JEDEC MS-013 AB.

X595 48-Pin SSLGA

TOP SIDE VIEW

BOTTOM SIDE VIEW

X550 28-Pin SOIC

SYM	INCHES		MILLIMETERS	
	MIN	MAX	MIN	MAX
A	.093	.104	2.35	2.65
A1	.004	.012	.10	.30
B	.013	.020	.33	.51
C	.009	.013	.23	.32
D	.697	.713	17.70	18.10
E	.291	.299	7.40	7.60
e	.050 BSC		1.27 BSC	
H	.394	.419	10.00	10.65
h	.010	.029	.25	.75
L	.016	.050	.40	1.27
α	0°	8°	0°	8°

NOTE: This drawing will meet all dimensions requirement of JEDEC MS-013 AE.

X585 44-Pin PLCC

SYM	INCHES		MILLIMETERS	
	MIN	MAX	MIN	MAX
A	.160	.180	4.06	4.57
A1	.100	.120	2.54	3.05
A2	.070	.090	1.78	2.29
b	.015	.022	0.38	0.56
b1	.026	.032	0.66	0.81
c	.018	.023	0.46	0.58
D, E	.685	.695	17.40	17.65
D1, E1	.640	.655	16.26	16.64
D2, E2	.310	.325	7.87	8.26
D3, E3	.280	.300	7.11	7.62
e	.050 BSC		1.27 BSC	
Q	.040	.050	1.02	1.27

NOTE: 1. This drawing will meet all dimensions requirement of JEDEC outline MS018 AC.
2. Leads terminals are Pb-free solder plated.

Dimensions in mm and inches (1 mm = 0.0394")

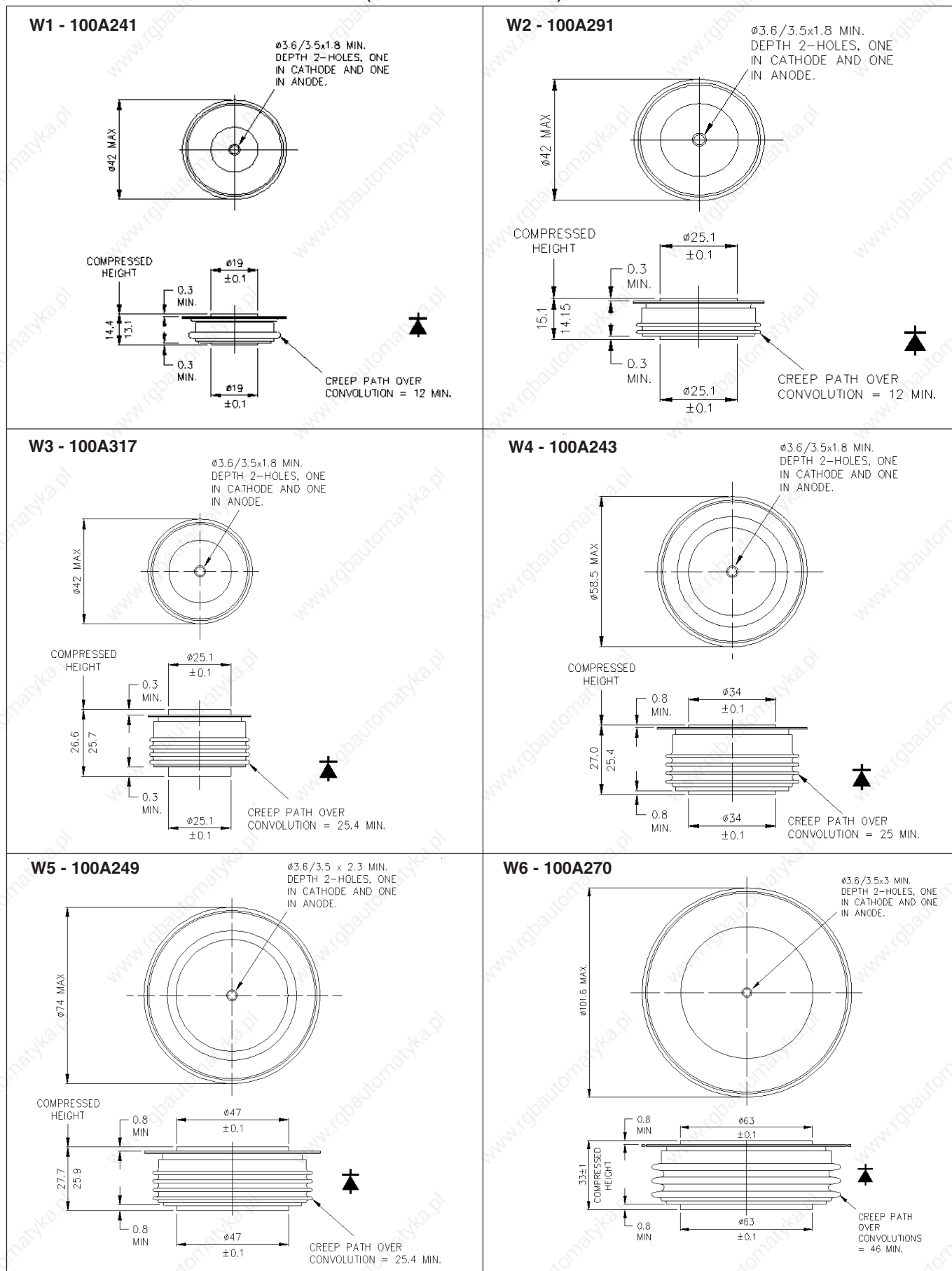

Dimensions in mm and inches (1 mm = 0.0394")

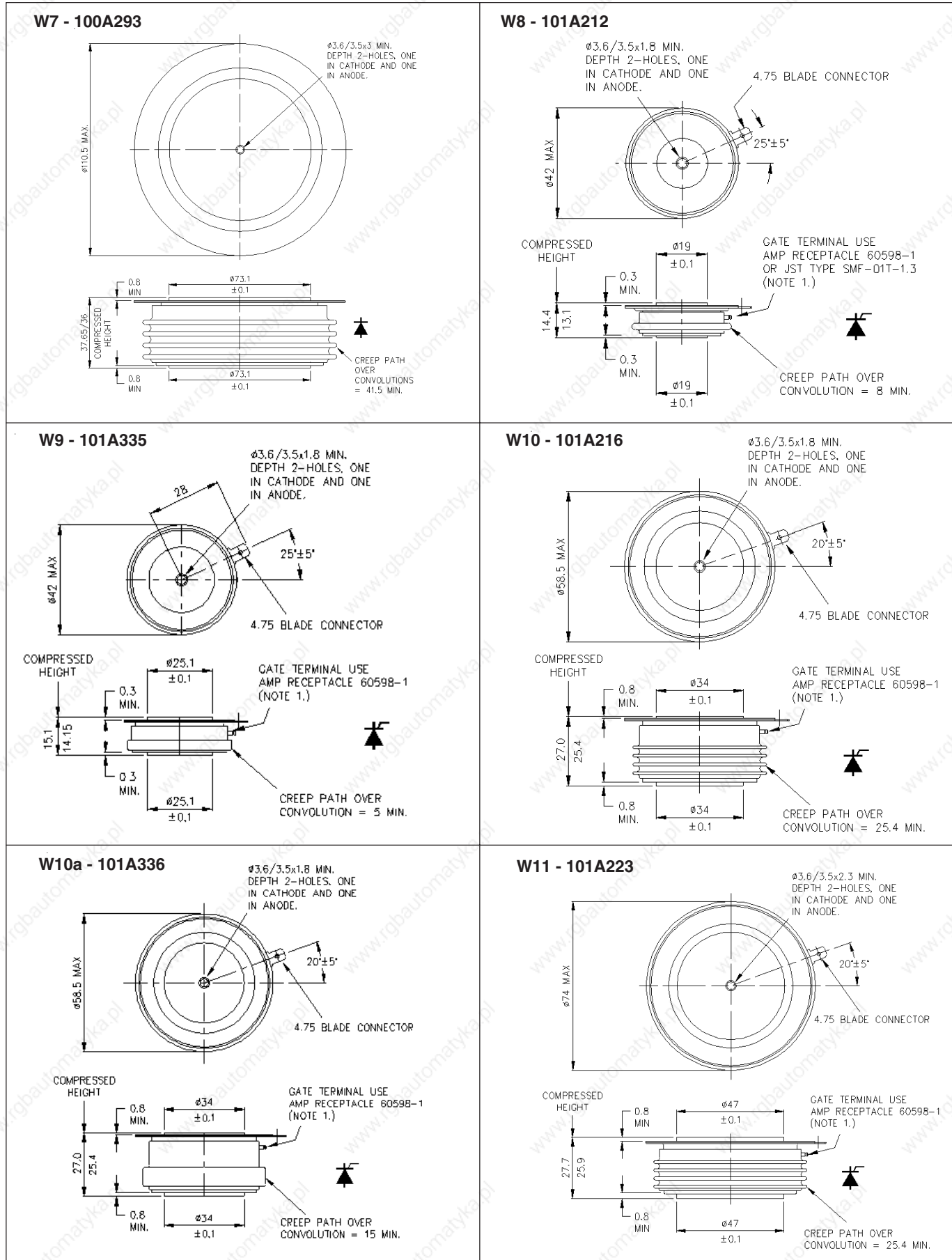

Dimensions in mm and inches (1 mm = 0.0394")

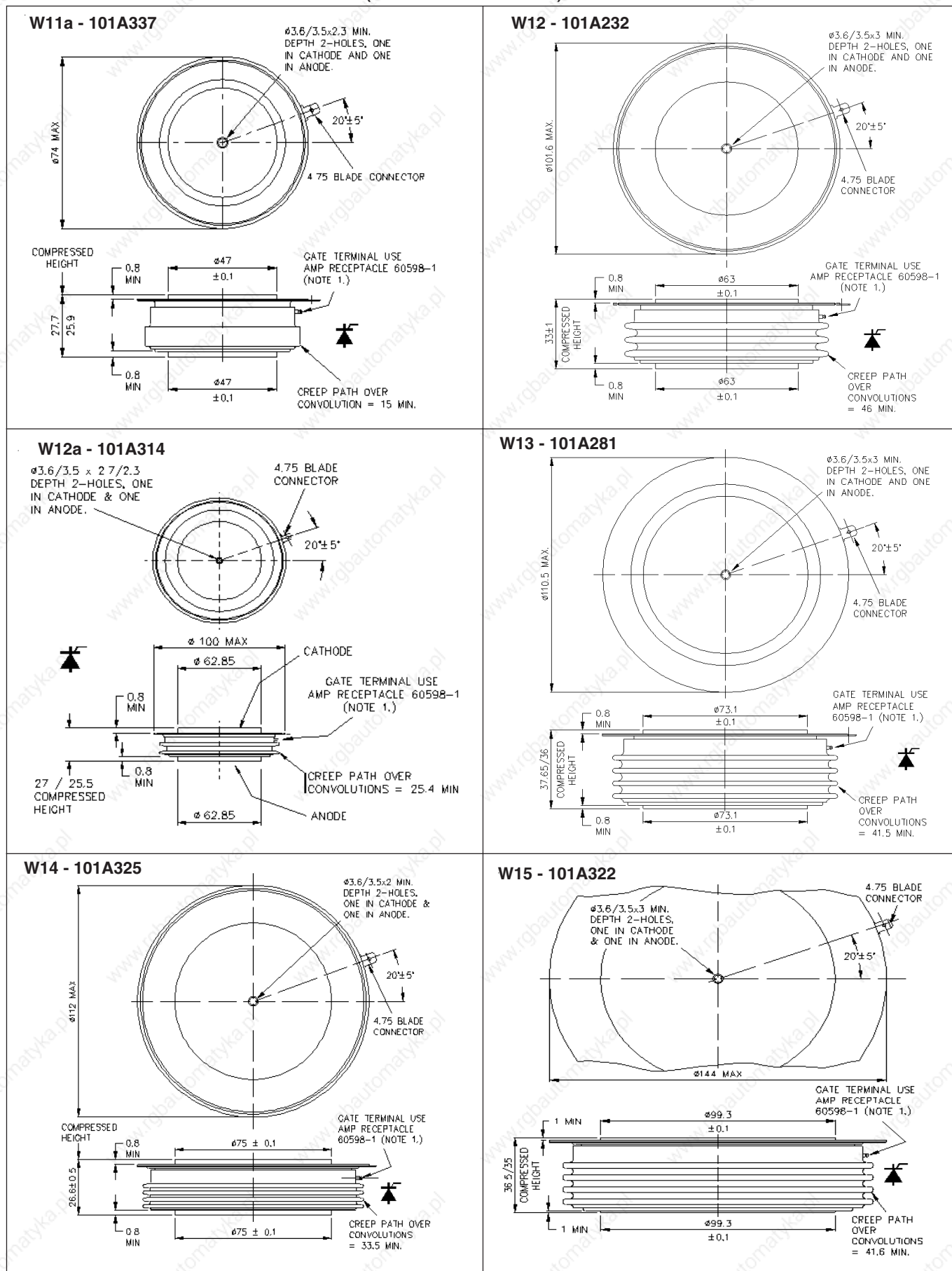

Dimensions in mm and inches (1 mm = 0.0394")

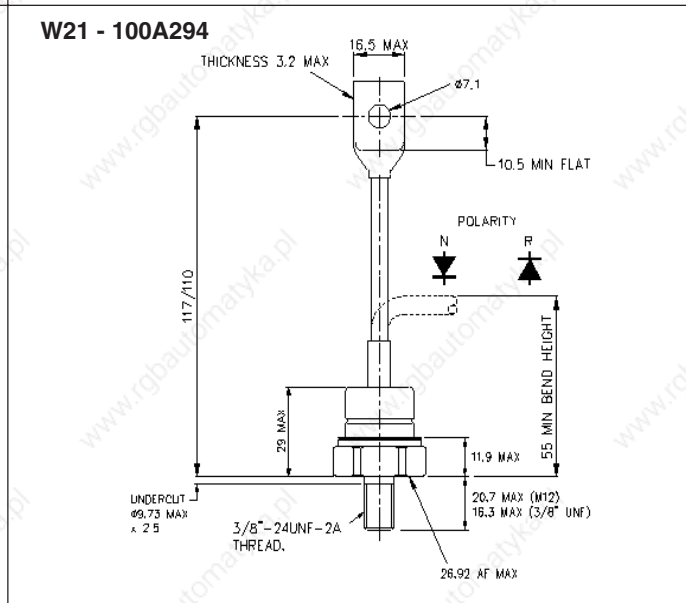
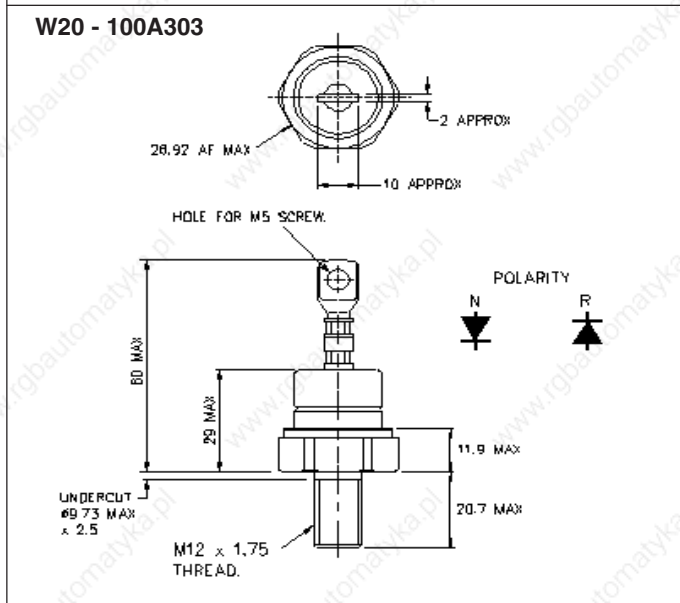
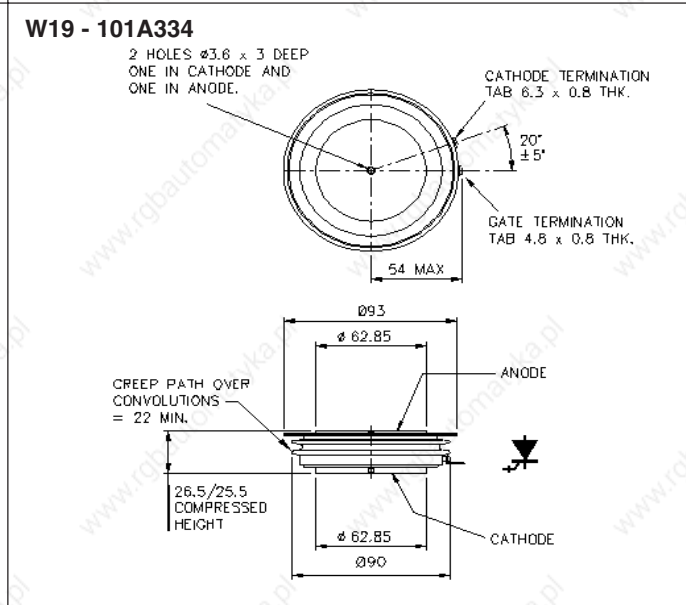
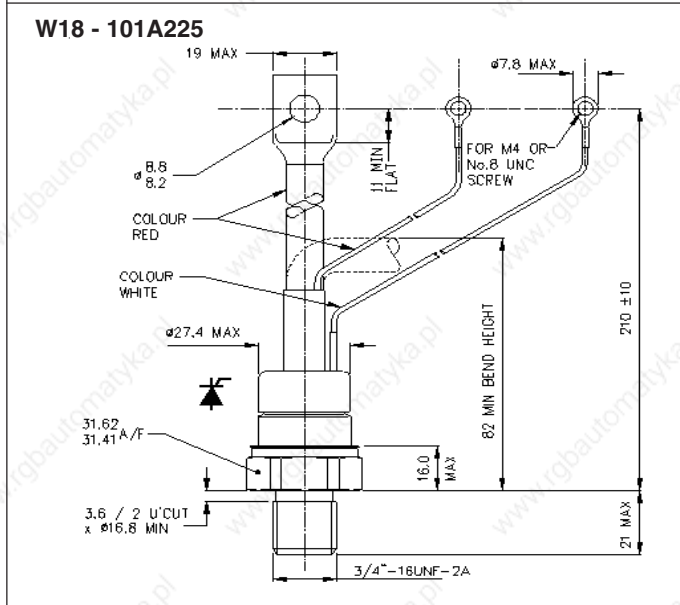
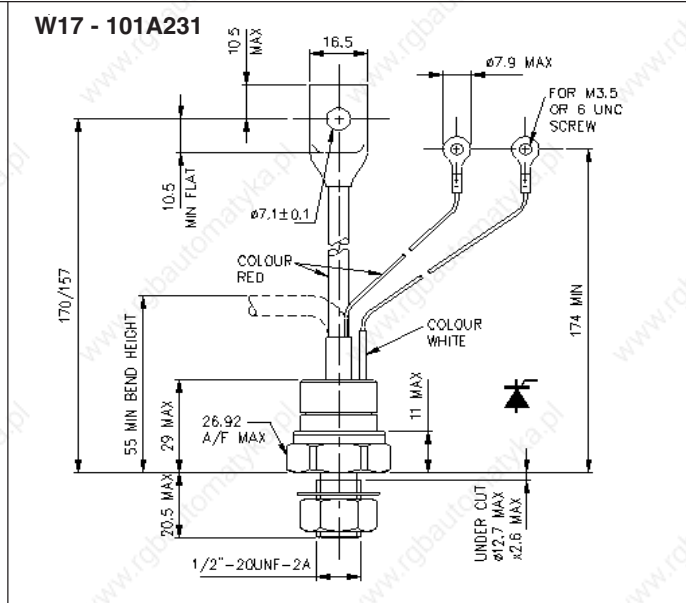
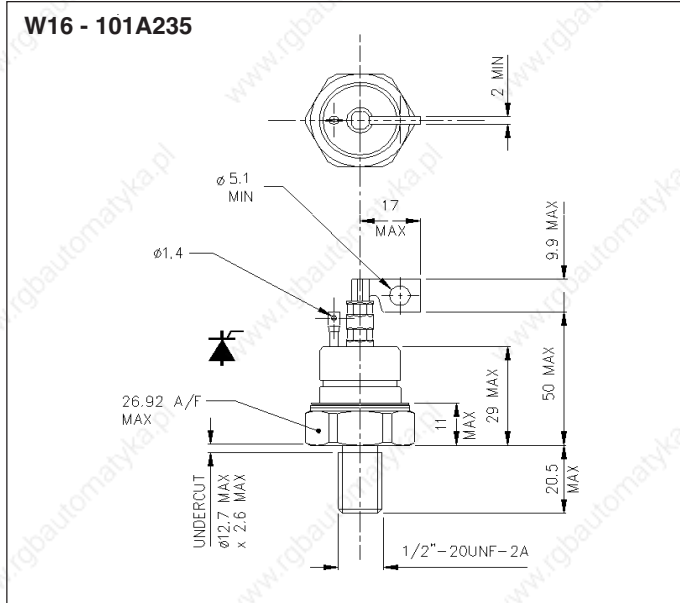

Dimensions in mm and inches (1 mm = 0.0394")

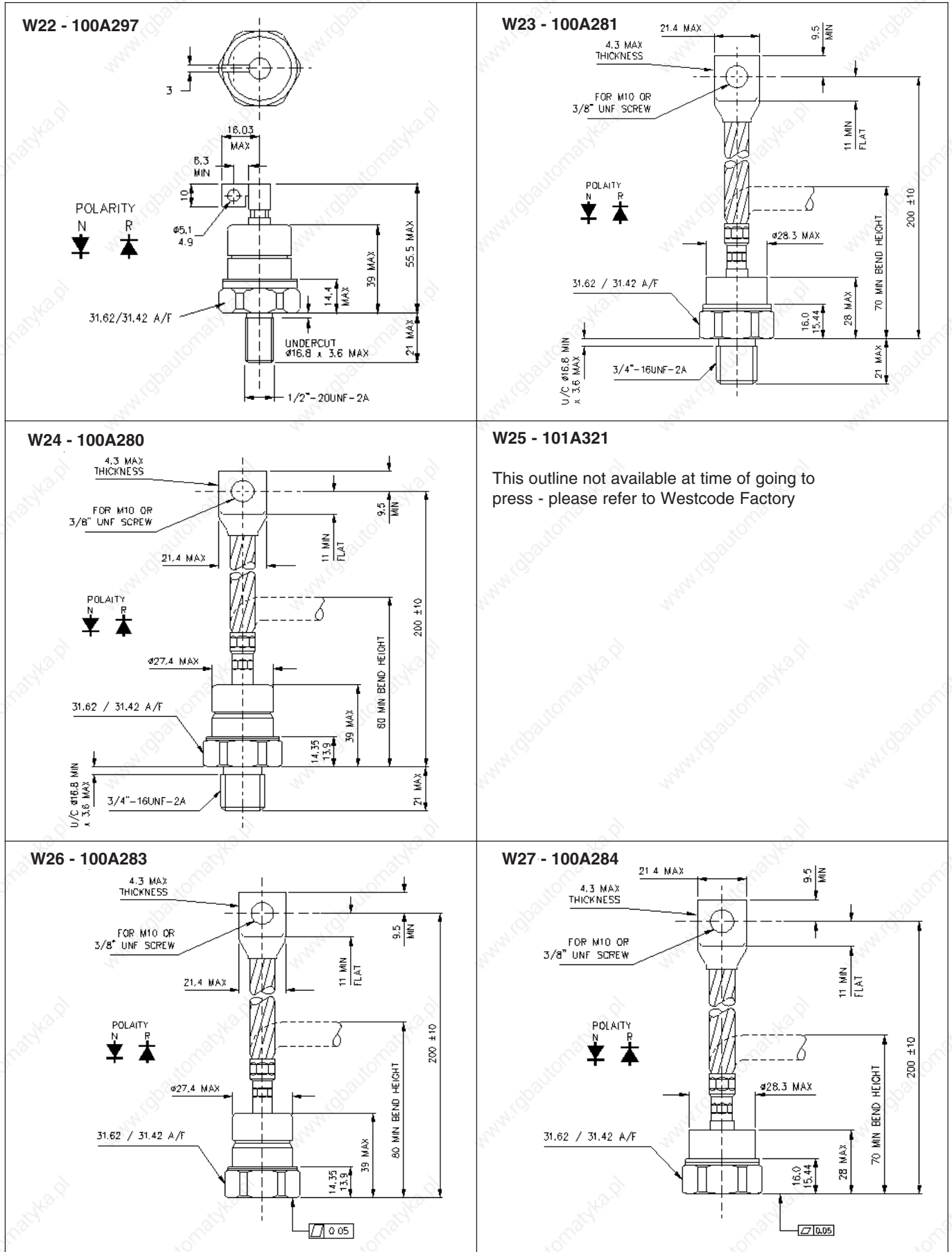

Dimensions in mm and inches (1 mm = 0.0394")

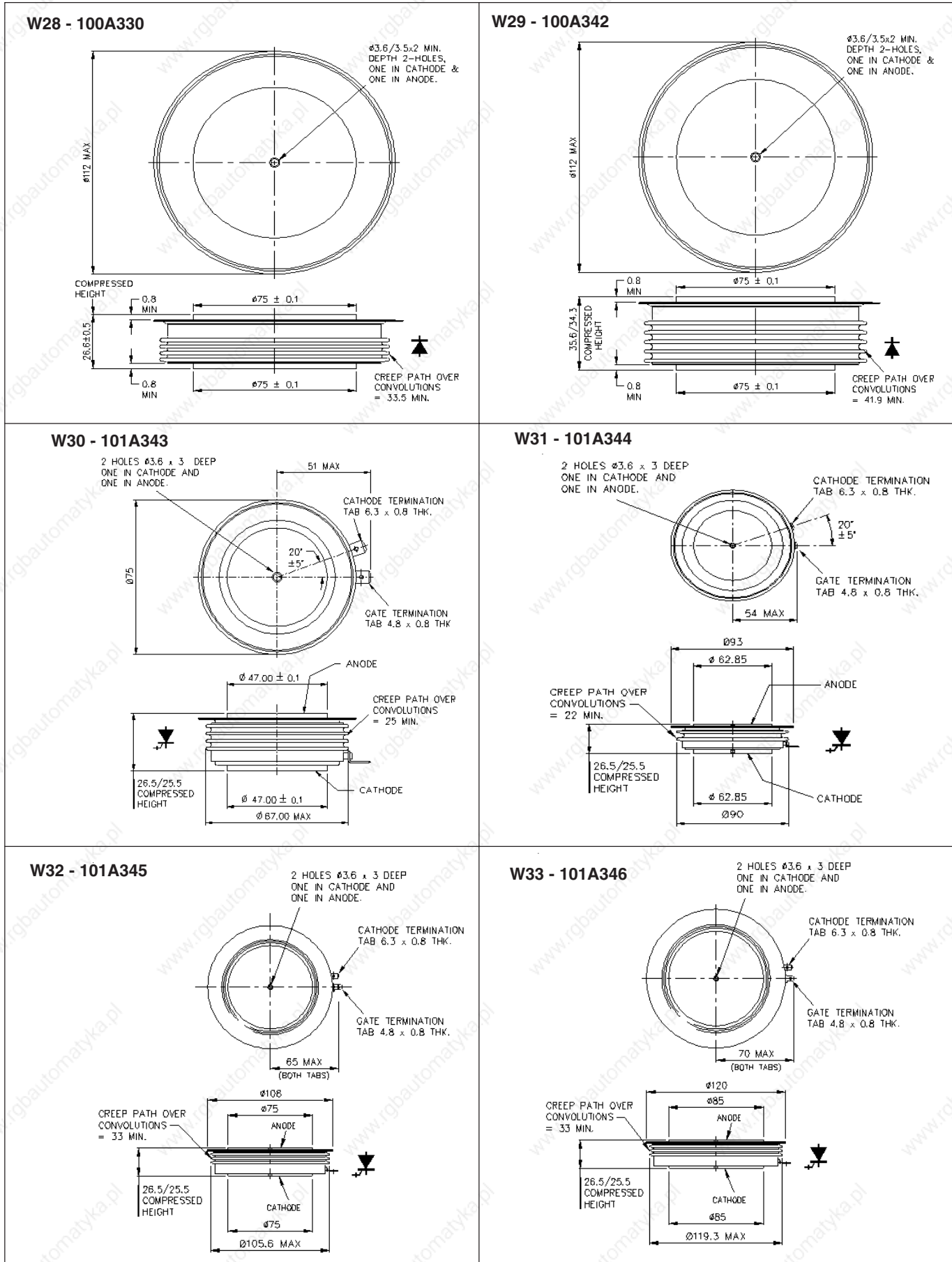

Dimensions in mm and inches (1 mm = 0.0394")

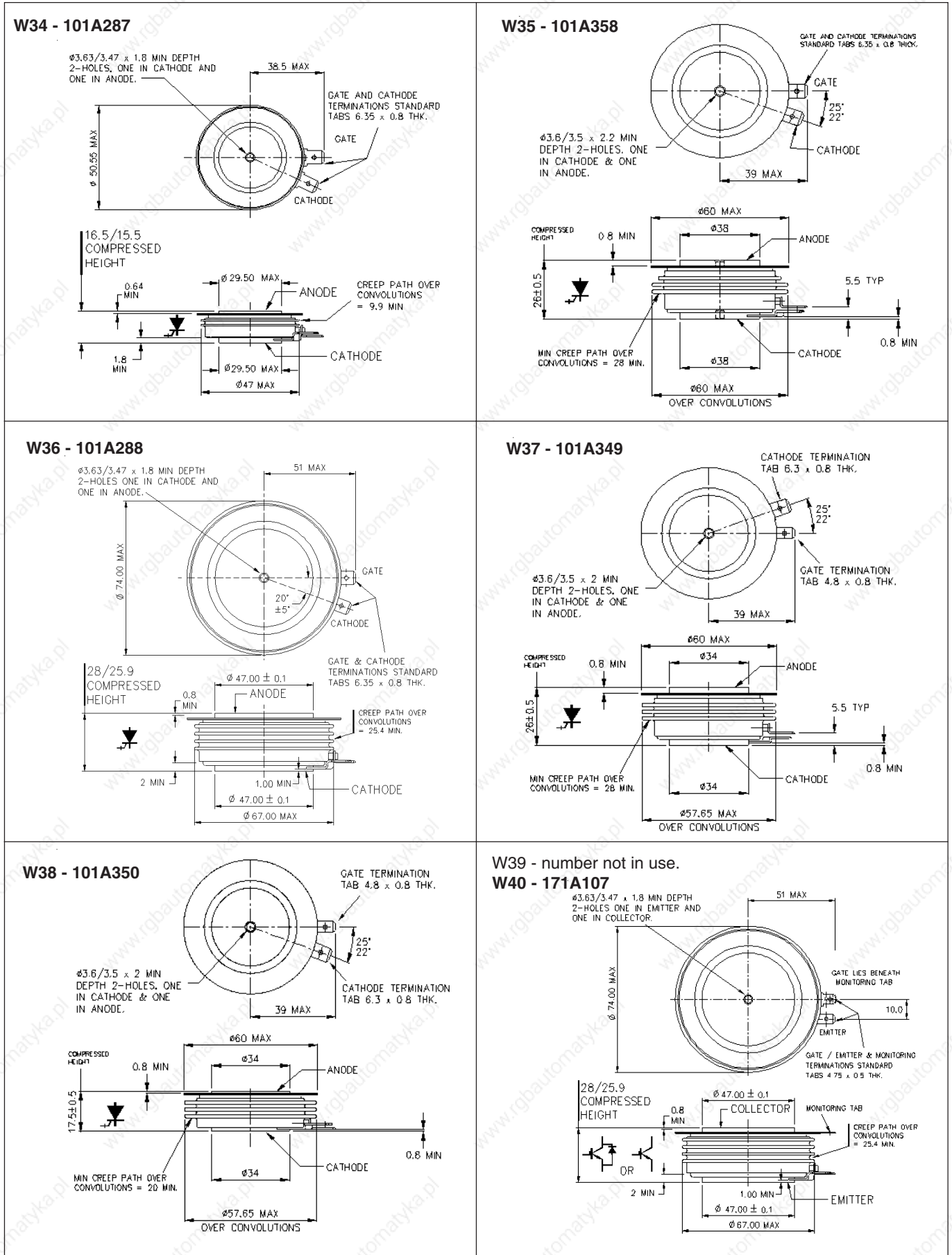

Dimensions in mm and inches (1 mm = 0.0394")

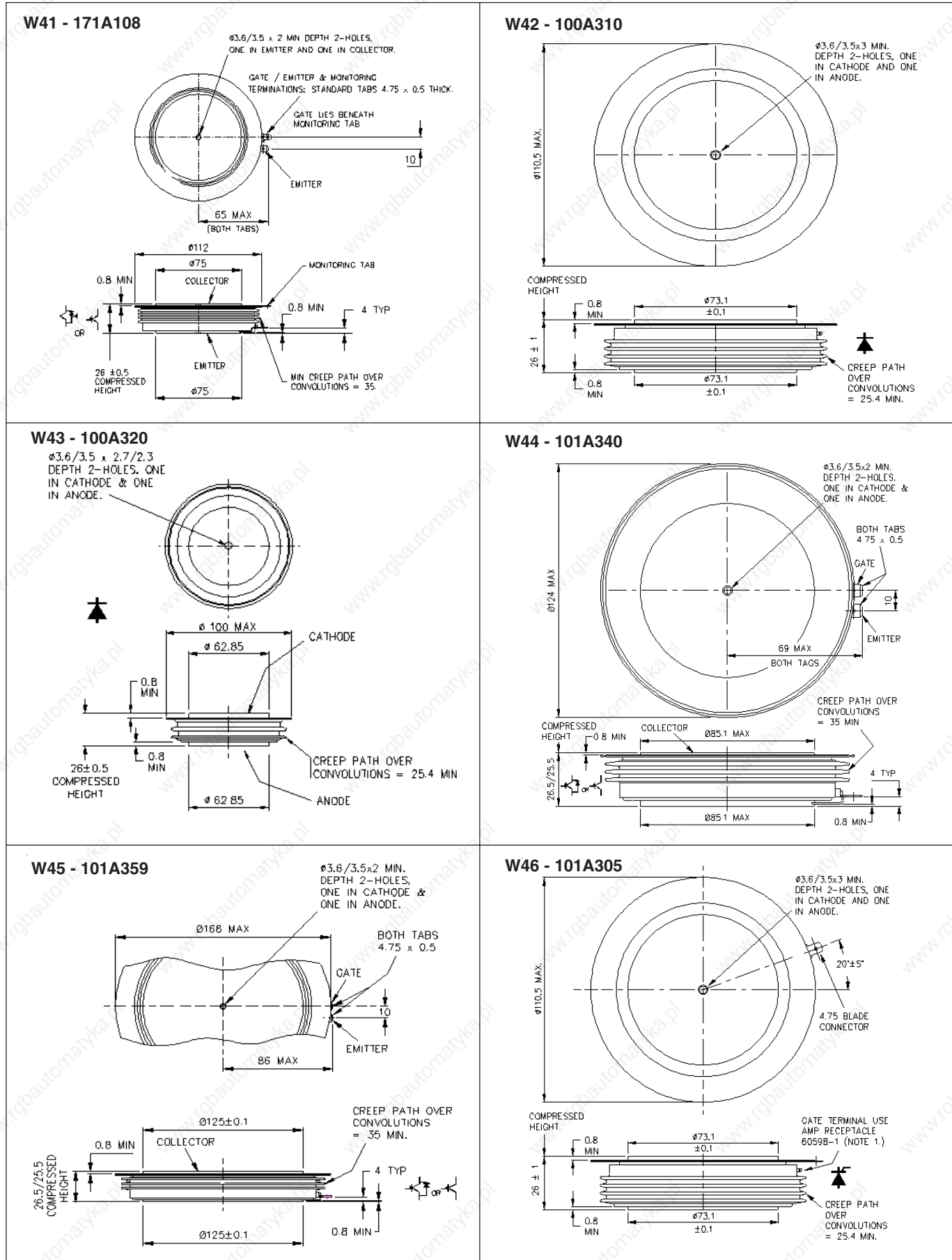

Dimensions in mm and inches (1 mm = 0.0394")

W47 - number not in use
W48 - 101A347

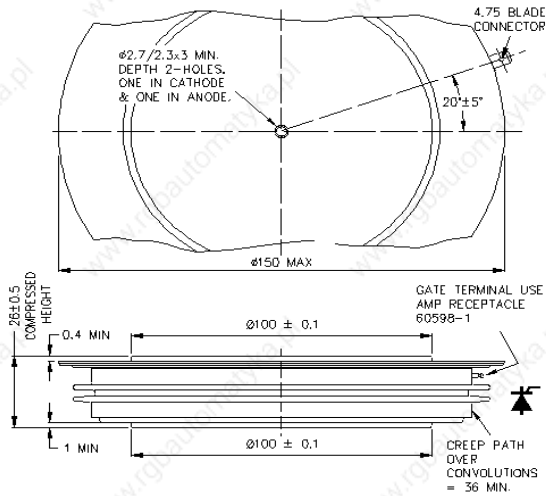

W49 - 150A111

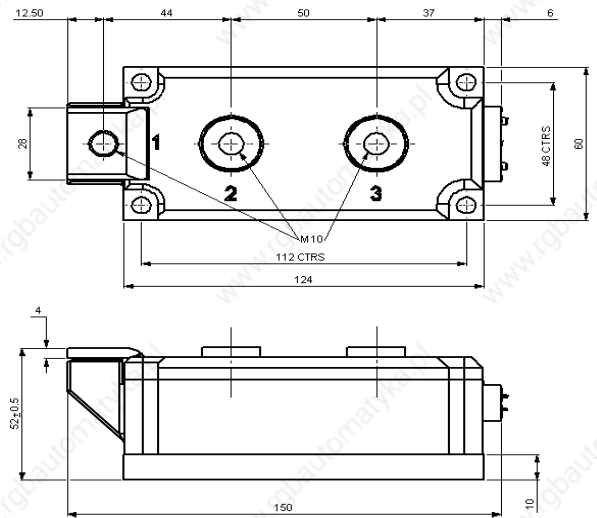

W50 - 101A309

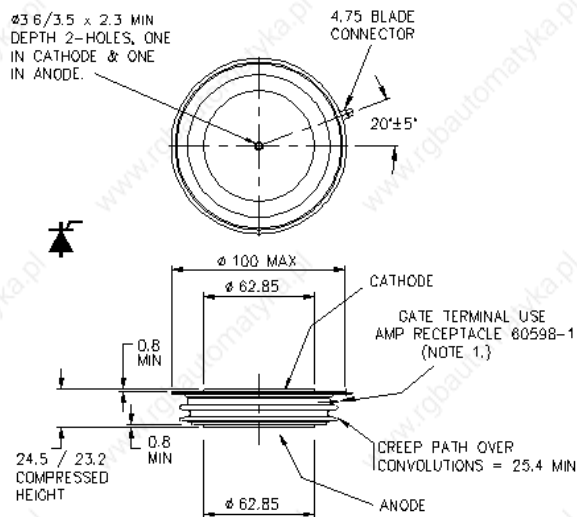

WP1 - 101A361

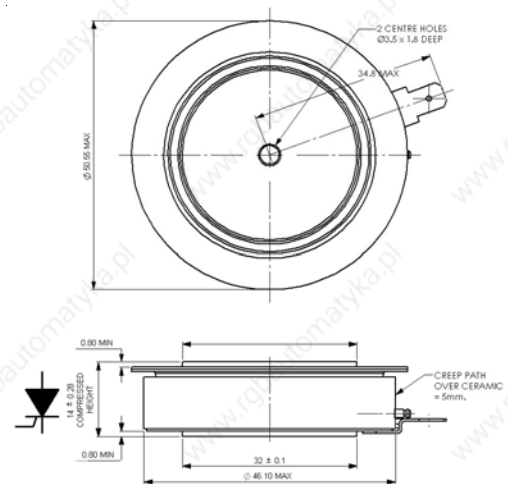

WP2 - 101A354

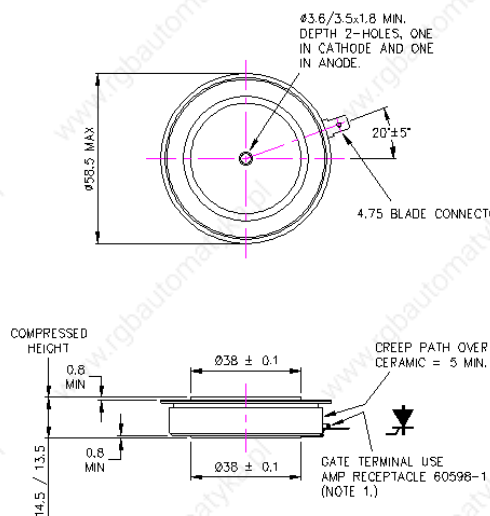

WP3 - 101A353

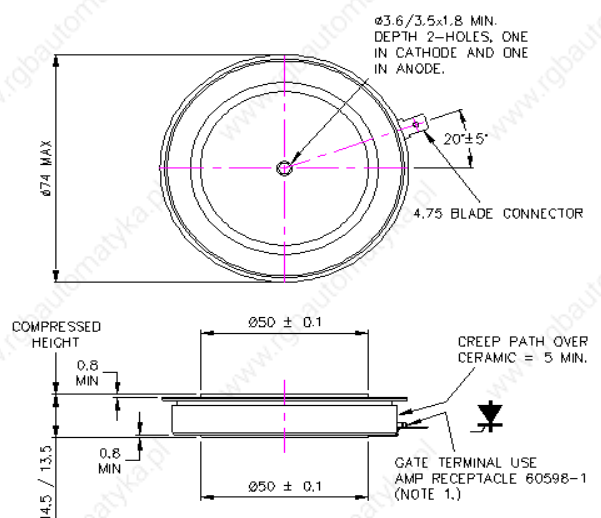

Dimensions in mm and inches (1 mm = 0.0394")

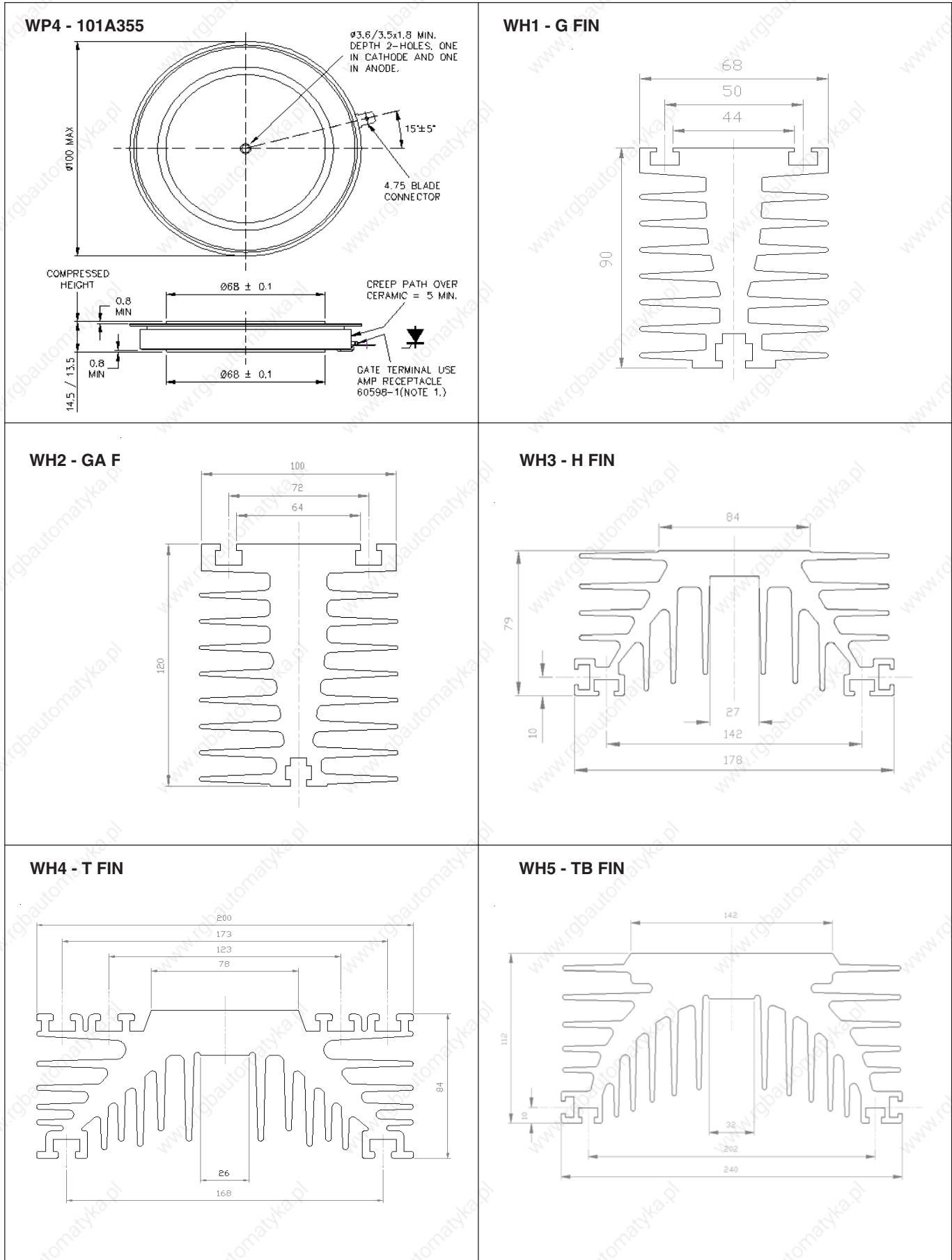

Dimensions in mm and inches (1 mm = 0.0394")

<p>WH6 - TC FIN</p>	<p>WH7 - LP100 FIN</p>
<p>WH8 - WS30 COPPER FIN</p>	<p>WH9 - WS46 FIN</p>
<p>WH10 - LK COOLER</p> <p>Nozzles suitable for 10mm hose</p>	<p>WH11 - LKA COOLER</p> <p>Nozzles suitable for 10mm hose</p>

Dimensions in mm and inches (1 mm = 0.0394")

WH12 - LKB COOLER

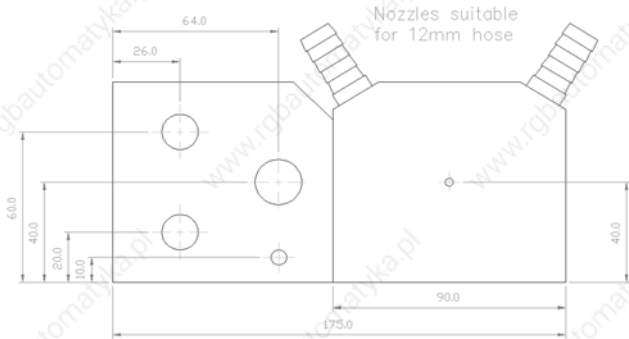

WH13 - LKC COOLER

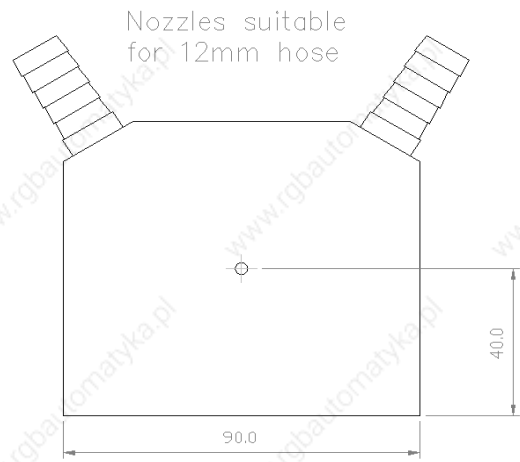

WH14 - WS27 COOLER

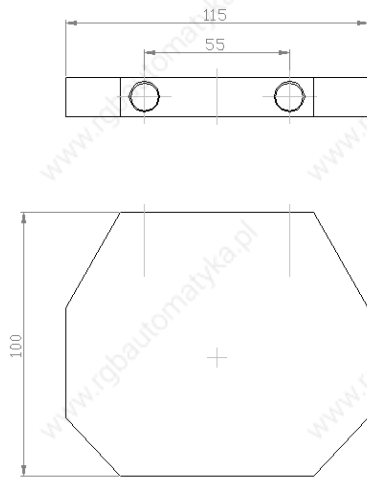

IXYS Sales Representatives North America & Canada

Country	Authorized for					Company	Phone	Fax	Email
	IXYS	Westcode	Clare	IXYS RF	MwT				
Alabama						• Holmes & Associates Inc	931-473-7155	931-473-7216	everett@egholmes.com
	•	•	•	•	•	MEC	256-351-0352	256-351-4081	tom@mec-corp.com
Alaska	•	•	•	•	•	Advanced Technical Mktg.	425-869-7636	425-869-9841	sales@a-t-m-l-.com
Arizona						• Odyssey 1	602-284-4407	928-223-0003	billm@odyssey1.biz
	•	•	•	•	•	MindShare Technical Sales	480-945 7157	480-945 7156	info@mindsharetechnical.com
Arkansas						• Commtech Sales	972-562-0555	972-542-8335	jerry.mcgraw@commtechsales.com
					•	Norcom, Inc.	972-386-4888	972-386-4907	dallas@norcomtexas.com
California	•	•	•	•	•	Fusion Technical Sales	408-496-6068	408-588-4017	info@fusiontechnical.com
					•	West Electronic Sales	760-929-1615	760-929-1619	west@westelec.com
	•	•	•	•	•	SCA	858-792-1101	858-793-9818	slodor@ix.netcom.com
	•	•	•	•	•	West Electronic Sales	714-465-3720	714-465-3734	west@westelec.com
						• Steward Technology	408-432-7393	408-432-7358	john@stechrep.com
						• Wes K	949-421-0124	949-421-0127	wes-k@wes-k.com
Colorado	•	•		•		AKI Enterprises	303-756-0700	303-756-3135	dean@akienterprises.com
					•	Lange Sales	303-795-5462	303-809-8270	dwhite@langesales.com
						• Odyssey 1	303-773-8176	303-773-8240	billm@odyssey1.biz
Connecticut						• Matrix Sales	978-459-4000	978-937-5882	matrix@matrixsalesinc.com
	•	•		•		SJ New England	203-723-4707	203-723-1629	info@sjassoc.com
					•	JEBCO	203-265-1318	203-265-1318	csteele@jebco.net
Delaware						• Engineering Techniques	410-453-0594	410-453-0596	etsinc@erols.com
					•	Nexus Technology	215-942-7868	215-942-0731	kmayer.nexus@verizon.net
	•	•		•		SJ Mid-Atlantic	856-866-1234	856-866-8627	info@sjassoc.com
Florida						• Holmes & Associates Inc	800-331-8417	813-884-1764	bobduke@egholmes.com
	•	•	•	•	•	MEC	954-426-8944	954-570-8568	bob@mec-corp.com
Georgia						• Holmes & Associates Inc	931-473-7155	931-473-7216	everett@egholmes.com
	•	•	•			MEC	770-985-6599		jcorbitt@mec-corp.com
Hawaii	•				•	N. A. Corporate Sales	408-982-0700	408-496-0670	sales@ixys.net
Idaho	•				•	Advanced Technical Mktg.	503-643-8307	503-643-4364	sales@a-t-m-l-.com
						• Odyssey 1	801-485-4728	801-485-4753	don@odyssey1.biz
Illinois	•	•		•	•	AEM, Inc.	314-298-9900	314-298-8660	dmoore@aemrep.com
	•	•	•	•	•	Martan, Inc.	847-330-3200	847-330-0024	sales@martaninc.com
Indiana	•	•		•	•	R.O. Whitesell & Assoc.	317-876-9000	317-876-0434	edna_baker@whitesell.com
					•	Rathsburg Associates, Inc.	317-818-7055	317-818 7060	Mail@rathsburg.com
					•	Rathsburg Associates, Inc.	574-642-4585	574-442 4060	Mail@rathsburg.com
Iowa	•	•	•	•	•	AEM, Inc.	913-393-4100	319-377-1539	tmaring@aemrep.com
Kansas	•	•		•	•	AEM, Inc.	913-393-4100	913-393-4044	mbarnes@aemrep.com
					•	Martan, Inc.	847-330-3200	847-330-0024	sales@martaninc.com
Kentucky	•	•		•	•	R.O. Whitesell & Assoc.	859-277-4904	859-277-5116	edna_baker@whitesell.com
					•	Rathsburg Associates, Inc.	317-818-7055	317-818-7060	Mail@rathsburg.com
Louisiana						• Commtech Sales	972-234-1447	972-234-5454	jerry.mcgraw@commtechsales.com
					•	Norcom, Inc.	972-386-4888	972-386-4907	dallas@norcomtexas.com
Maine						• Matrix Sales	978-459-4000	978-937-5882	matrix@matrixsalesinc.com
	•	•		•		SJ New England	508-485-2700	508-485-2702	info@sjassoc.com
					•	JEBCO	978-251-1300	978-251-3533	csboeingqjebconet.com
Maryland						• Engineering Techniques	410-453-0594	410-453-0596	etsinc@erols.com
	•	•		•		SJ Chesapeake	703-533-2233	703-533-2236	jland@sjassoc.com
					•	Contact Clare Directly	978-524 6400		sales@clare.com
Massachusetts						• Matrix Sales	978-459-4000	978-937-5882	matrix@matrixsalesinc.com
	•	•		•		SJ New England	508-485-2700	508-485-2702	info@sjassoc.com
					•	JEBCO	978-251-1300	978-251-3533	csboeingqjebconet.com
Michigan	•	•		•	•	R.O. Whitesell & Assoc.	248-473-5454	248-473-1165	edna_baker@whitesell.com
					•	Rathsburg Associates, Inc.	616-554-1460	616-554 1462	Mail@rathsburg.com
					•	Rathsburg Associates, Inc.	248-615-4000	248-615-4001	Mail@rathsburg.com

IXYS Sales Representatives North America & Canada

Country	Authorized for					Company	Phone	Fax	Email
	IXYS	Westcode	Clare	IXYS RF	M/W/T				
Minnesota					•	Northstar Technology	952-831-6777	952-831-7076	dennis@northstartech.com
	•	•	•	•	•	Hanna Lind Ltd.	952-931-1242	952-931-3015	hlsales@hannalind.com
Mississippi	•	•	•	•	•	MEC	256-351-0352	256-351-4081	tom@mec-corp.com
Missouri	•	•	•	•	•	AEM, Inc.	314-298-9900	314-298-8660	dmoore@aemrep.com
			•		•	Martan, Inc.	636-939-3300	636-447-1371	sales@martaninc.com
Montana					•	Odyssey 1	801-485-4728	801-485-4753	don@odyssey1.biz
	•				•	AKI Enterprises	303-756-0700	303-756-3135	dean@akienterprises.com
Nebraska	•	•			•	AEM, Inc.	402-328-8311	775-254-5887	tczap@aemrep.com
Nevada					•	Steward Technology	408-432-7393	408-432-7358	john@stechrep.com
					•	Wes K	949-421-0124	949-421-0127	wes-k@wes-k.com
	•				•	Fusion Technical Sales	408-955-9525	408-955-9581	info@fusiontechnical.com
	•	•	•	•	•	MindShare Technical Sales	480-945 7157	480-945 7156	info@mindsharetechnical.com
NewHampshire					•	Matrix Sales	978-459-4000	978-937-5882	matrix@matrixsalesinc.com
	•	•			•	SJ New England	508-485-2700	508-485-2702	info@sjassoc.com
			•			JEBSCO	978-251-1300	978-251-3533	csboeingqjebconet.com
New Jersey					•	Nexus Technology	631-843-0100	631-843-9176	inatalie@nexustec.com
	•				•	SJ Mid-Atlantic	856-866-1234	856-866-8627	info@sjassoc.com
Southern NJ	•	•			•	SJ Associates	856-866-1234	856-866-8627	info@sjassoc.com
Northern NJ					•	Microcom Sales	908-370-6990	908-654-3428	jjackson@microcomsales.com
Southern NJ					•	Scientific Devices	215-256-8641	215-256-8642	john@scidev-phila.com
New Mexico					•	Odyssey 1	602-861-0704	928-223-0003	bill@odyssey1.biz
	•	•	•	•	•	MindShare Technical Sales	480-945 7157	480-945 7156	info@mindsharetechnical.com
New York					•	Microcom Sales	908-370-6990	908-654-3428	jjackson@microcomsales.com
	•	•	•	•	•	L-Mar Associates	585-899-3920	585-899-3931	wendy.milleed@l-mar.com
					•	Nexus Technology	631-843-0100	631-843-9176	inatalie@nexustec.com
	•	•			•	SJ Associates, Inc.	516-536-4242	516-536-9638	info@sjassoc.com
North Carolina					•	Holmes & Associates Inc	919-387-1072	919387-1077	mike@egholmes.com
	•	•	•	•	•	MEC	919-215-2555	954-570-8568	bob@mec-corp.com
North Dakota					•	Northstar Technology	952-831-6777	952-831-7076	dennis@northstartech.com
	•	•	•	•	•	Hanna Lind Ltd.	952-931-1242	952-931-3015	hlsales@hannalind.com
Ohio	•	•			•	R.O. Whitesell & Assoc.	216-661-2613	216-661-3192	edna_baker@whitesell.com
					•	Rathsburg Associates, Inc.	440-838-8100	440-128-8397	mark@rathsburg.com
					•	Rathsburg Associates, Inc.	614-777-5915	937-291-1450	mark@rathsburg.com
					•	Rathsburg Associates, Inc.	937-291-4001	937-291-1450	mark@rathsburg.com
Oklahoma					•	Commtech Sales	972-562-0555	972-542-8335	jerry.mcgraw@commtechsales.com
					•	Norcom, Inc.	972-386-4888	972-386-4907	dallas@norcomtexas.com
Oregon	•	•	•	•	•	Advanced Technical Mktg.	503-643-8307	503-643-4364	sales@a-t-m-l.com
					•	Lionheart Northwest, Inc.	425-882-2587	425-952-8739	sales@lionheartnw.com
Pennsylvania					•	Nexus Technology	215-942-7868	215-942-0731	kmayer.nexus@verizon.net
					•	Scientific Devices	215-256-8641	215-256-8642	john@scidev-phila.com
	•					Adel	216-661-2613	261-661-3192	
	•	•			•	SJ Mid-Atlantic	856-866-1234	856-866-8627	info@sjassoc.com
					•	Rathsburg Associates, Inc.	724-865-9511	724-865-9811	mark@rathsburg.com
Rhode Island					•	Matrix Sales	978-459-4000	978-937-5882	matrix@matrixsalesinc.com
	•	•			•	SJ New England	508-485-2700	508-485-2702	info@sjassoc.com
					•	JEBSCO	978-251-1300	978-251-3533	csboeingqjebconet.com
South Carolina					•	Holmes & Associates Inc	919-387-1072	919-387-1077	mike@egholmes.com
	•	•	•	•	•	MEC	919-215-2555	313-557-0617	jcorbitt@mec-corp.com
South Dakota	•				•	Hanna Lind Ltd.	952-931-1242	952-931-3015	hlsales@hannalind.com
					•	Northstar Technology	952-831-6777	952-831-7076	dennis@northstartech.com
Tennessee					•	Holmes & Associates Inc	931-473-7155	931-473-7216	everett@egholmes.com
	•	•	•	•	•	MEC	256-351-0352	256-351-4081	jcorbitt@mec-corp.com

IXYS Sales Representatives North America & Canada

Country	Authorized for					Company	Phone	Fax	Email
	IXYS	Westcode	Clare	IXYS RF	MwT				
Texas						• Commtech Sales	972-562-0555	972-542-8335	jerry.mcgraw@commtechsales.com
						• Norcom, Inc.	972-386-4888	972-386-4907	dallas@norcomtexas.com
						• Odyssey 1	602-861-0704	928-223-0003	billm@odyssey1.biz
Utah	•	•				• AKI Enterprises	801-763-0780	801-763-7841	mike@akienterprises.com
						• Odyssey 1	801-485-4728	801-485-4753	don@odyssey1.biz
Vermont						• Matrix Sales	978-459-4000	978-937-5882	matrix@matrixsalesinc.com
	•	•				• SJ New England	508-485-2700	508-485-2702	info@sjassoc.com
						• JEBCO	978-251-1300	978-251-3533	csboeingqjebconet.com
Virginia						• Engineering Techniques	410-453-0594	410-453-0596	etsinc@erols.com
	•					• SJ Chesapeake	703-533-2233	703-533-2236	info@sjassoc.com
						• Contact Clare Directly	978-524 6400		sales@clare.com
Washington	•	•	•	•		• Advanced Technical Mktg.	425-869-7636	425-869-9841	sales@a-t-m-l-.com
						• Lionheart Northwest, Inc.	425-882-2587	425-952-8739	sales@lionheartnw.com
Washington DC	•					• SJ Chesapeake	703-533-2233	703-533-2236	info@sjassoc.com
						• Contact Clare Directly	978-524 6400		sales@clare.com
West Virginia						• Engineering Techniques	410-453-0594	410-453-0596	etsinc@erols.com
	•	•				• R.O. Whitesell & Assoc.	614-888-9396	614-888-8792	edna_baker@whitesell.com
Wisconsin	•	•	•	•		• Martan, Inc.	847-330-3200	847-330-0024	sales@martininc.com
Wyoming	•					• AKI Enterprises	303-756-0700	303-756-3135	dean@akienterprises.com
						• Odyssey 1	801-485-4728	801-485-4753	don@odyssey1.biz
Central Canada	•	•	•			• CMT-Remark, Inc.	905-612-0900	905-612-0905	emccarrel@cmt-renmark.com
		•				• Iconopower	613-744-3670	613-744-8452	mike@iconopower.com
Canada						• Giga-Tron Assoc. Ltd.	613-747-4114	613-747-3474	greg@gigatron.com
Eastern Canada	•	•	•			• CMT-Remark, Inc.	450-510-2003	450-468-6363	rmorin@cmt-renmark.com
	•					• Advanced Technical Mktg.	450-510-2003		sales@a-t-m-l-.com
		•				• Iconopower	613-744-3670	613-744-8452	mike@iconopower.com
Montreal						• Giga-Tron Associates	514-984-2598	514-620-7812	greg.payne@gigatron.com
						• Giga-Tron Associates	519-220-1856	519-220-1938	greg.payne@gigatron.com
Cambridge						• Giga-Tron Associates	403-257-0636	403-257-0569	karen.white@gigatron.com
Calgary	•	•	•			• CMT-Remark, Inc.	403-225-3033	403-271-2395	mmorton@cmt-renmark.com
		•				• Iconopower	613-744-3670	613-744-8452	mike@iconopower.com
	•					• Advanced Technical Mktg.	905-794-5326		sales@a-t-m-l-.com
	•					• Advanced Technical Mktg.	613-223-3925		sales@a-t-m-l-.com
	•					• CMT-Remark Inc.	613-223-3925		sales@a-t-m-l-.com
	•					• Advanced Technical Mktg.	604-875-6066		sales@a-t-m-l-.com
	•					• Advanced Technical Mktg.	604-875-6066		sales@a-t-m-l-.com

IXYS Distributors North America & Canada

Authorized for					Company	Phone	Web Site
IXYS	Westcode	Clare	IXYS RF	MwT			
•		•			All American	1-800-573-ASAP	www.allamerican.com
		•			Allied	1-800-433-5000	www.alliedelect.com
•					Darrah	216-631-0912	becdarrah@erthlink.net
•		•			Digi-Key	1-800-DIGI-KEY	www.digikey.com
•		•			Future Electronics	1-800-388-3731	www.future.com
•					Hughes Peters	937-235-7100	www.hughespeters.com
		•			Master	1-800-421-8153	www.masterdistributors.com
		•			Newark	1-800-463-9275	www.newark.com
•		•			Nu Horizons	1-888-747-NUHO	www.newhorizons.com
			•		RFMW	408-350-8318	www.rfmw.com

IXYS Sales Representatives and Distributors Central & South America

Country	Authorized for					Company	Phone	Fax	Email
	IXYS	Westcode	Clare	IXYS RF	MwT				
Puerto Rico	•	•	•			MEC	787-790-5532	787-708-1054	jon@mec-corp.com
Mexico		•				MindShare Technical Sales	480-945 7157	480-945 7156	info@mindsharetechnical.com
Central America			•			Latinrep de Mexico	52-33-3817-3900	33-3817-3010	enzot@latin-rep.com
Brazil		•				Corona Brazil Ind.Com E Repr Ltda	55-19-3935 3257	55-19-3935 3282	semicondutores@coronabrasil.com.br
		•	•			Masteronics Rep. Ltda	55-51-3312-6757	55-51-3312-6758	roberto@masteronics.com.br
				•		Vermont Representatives	55 11 37266655	55 11 37222791	altrevizan@vermont-rep.com
South America	•		•			Masteronics Rep. Ltda	55-51-3333-2874	55-51-3312-6758	roberto@masteronics.com.br

IXYS Sales Representatives and Distributors Japan

Country	Authorized for					Company	Phone	Fax	Email
	IXYS	Westcode	Clare	IXYS RF	MwT				
Japan					•	AMT Incorporated	+81 7 4230 0070	+81 7 4230 0200	sales@ad-mtech.com
	•	•		•		J-Rep Corporation Osaka	+81 6 6368 2111	+81 6 6368 2114	info@j-rep.com
	•	•		•		J-Rep Corporation Tokyo	+81 3 5789 2310	+81 3 3449 7844	tokyo@j-rep.com
	•	•				Nihon West Corporation	+81 4 7340 6701	+81 4 7340 6710	nwest@nihonwest.co.jp
			•			Global Electronic Corp.	+81 3 32601411	+81 3 32607100	arai@gec-tokyo.co.jp
				•		Unidux Inc.	+81 422 324500	+81 422 312050	okada@unidux.co.jp

IXYS Sales Representatives and Distributors Asia / Pacific / Middle East

Country	Authorized for					Company	Phone	Fax	Email
	IXYS	Westcode	Clare	IXYS RF	MWT				
Australia	•			•		Braemac Pty Limited	+61 2 9550 6600	+61 2 9550 6377	k.ottaway@braemac.com.nz
			•			Eaton IRH Components	+61 2 9693 9333	+61 2 9667 3702	toryrosa@eaton.com
			•			Semikron Pty.	+61 3 85615600	+61 3 95618769	tony.damelio@semikron.com
China	•	•		•		Advantage Power Ltd., ShenZhen	+86 755 8294 7272	+86 755 8294 7262	sales@szapl.com
	•	•		•		Advantage Power Ltd., Beijing	+86 10 6296 9270 / 6296	+86 10 6296 0085	sales@szapl.com
	•	•		•		Advantage Power Ltd, Shanghai	+86 21 3414 1365 / 5448	+86 21 6475 0953	sales@szapl.com
				•		ANV Shanghai	+86 21 5890 3528	+86 21 5890 0058	anvsh@online.sh.cn
				•		AsiaCom Techn. Ltd, ShenZhen	+86 755 8287/7333	+86 755 8287/7666	jemmy.lin@asiacom.com.cn
				•		AsiaCom Technology Ltd, WuHan	+86 27 8243 9240	+86 27 8243 9069	zxli@public.wh.hb.cn
		•				Chun Wang Electrical Limited	+86 20 8449 6073 / 6156	+86 20 8440 6960	info@ccsem.com
	•			•		Gangli Electronics	+86 51 9811 7388	+86 51 9810 4942	czgangli@public.cz.js.cn
	•			•		Karin Electronic Supplies Comp. Ltd	+852 2389 8252	+852 2343 6479	stephen.chong@karin.com.hk
	•			•		Revel Electronics Company Ltd	+86 20 8364 9251	+86 20 8364 9086	donaldyang@gzrevel.com
				•		Tektron Electronics Ltd, Shanghai	+86 21 6427 8233	+86 21 6427 0992	allanhuang@tekprc.com
				•		UST Company Limited, Beijing	+86 10 5155 0182 / 0183	+86 10 8208 5272	song@ustcn.com
						• ACA Technology (auth sales agent)	9094441013	9094440224	norman@acatec.com
					• Silicon Tech (auth sales agent)	862150595180	862150595190	frank.yang@siliconelec.com	
Egypt	•	•	•	•		Ozdisan Elektronik	+90 216 4663683	+90 216 4663686	export@ozdisan.com
Hong Kong	•	•		•		Advantage Power Ltd, Hong Kong	+852 6498 0762	+852 8161 3953	sales@szapl.com
				•		Chun Wang Electrical Comp. Ltd	+852 23312090	+852 2305 2377	info@chunwang.com.hk
	•			•		Karin Electronic Supplies Comp. Ltd	+852 2389 8252	+852 2372 6381	stephen.chong@karin.com.hk
	•			•		Revel Electronics Company Ltd	+852 2389 8891	+852 2389 2448	philipho@revel.com.hk
				•		Tektron Electronics (Hong Kong) Ltd	+852 2388 0629	+852 2780 5871	jasonchan@tek.com.hk
					• Anv Trading Co	6622611688	6622611689	anvtrading@pacific.net.th	
India			•			BBS Electronics Internat. Pvt. Ltd	+91 80 2530 6611	+91 80 2530 6610	vishvajit@bbsgroup.net
			•			Electric Controls Company	+91 22 2208 1223/5369	+91 22 2208 5177	sales@ecc.co.in
				•	•	Indosale Pvt Limited	+91 80 2364 0503	+91 80 2364 1170	elcam@vsnl.com
					• Pankaj Electronics	+91 11 2627 1049	+91 11 2627 3494	info@pankaj.biz	
Indonesia	•					PT Ometraco Arya Samanta	+62 21 619 6166	+62 21 619 3447	sales-eld@aos.co.id
	•			•		Bluetree Electronics Ltd	+65 6 3482247	+65 6 64555922	rfq@bluetree.com.sg
Israel	•					Bruno International Corporation	+972 3 570 5323	+972 3 570 5331	brn@brunocorp.co.il
	•	•	•			Future Electronics	+972 9 970 1414	+972 9 958 4333	alon.balash@futureelectronics.com
				•	•	MTI Engineering Limited	+972 39008900	+972 3 9008901	adi_p@mti-group.co.il
				•	•	Avnet	+972 9 778 0280	+972 3 760 1115	avnet.israel@avnet.com
Korea - South				•	•	AnyEparts	+82 31 713 4216	+82 31 713 8160	skkang@anyeparts.com
	•	•		•		Daan Electronics Co. Limited	+82 2 718 8033	+82 2 718 1161	skyim@daan.co.kr
	•	•		•		Daan Electronics Co. Ltd (Seoul)	+82 26 679 3614	+82 2 718 1161	oypark@daan.co.kr
	•	•		•		Daan Electronics Co. Ltd (Seoul)	+82 22 279 3614	+82 22 279 6496	syjeon@daan.co.kr
	•	•		•		Daan Electr. Co. Ltd (Daegu City)	+82 53 423 0192	+82 53 604 2650	eslee@daan.co.kr
	•	•		•		Daan Electr. Co. Ltd (Pusan City)	+82 51 802 9076	+82 51 802 5306	eslee@daan.co.kr
	•			•		GenCore (Seoul)	+82 23 463 0040	+82 23 463 4935	marketing@gencore.co.kr
	•			•		GenCore (Gumi)	+82 54 4571062	+82 54 457 1063	justinpark@gencore.co.kr
				•		Mainsail Mercantile Limited	+82 2 745 2761	+82 2 745 2766	mainsail@korea.com
				•		Mitech Corp.	+82 2 868 0551-2	+82 2 868 0557	mitechbk@chollian.net
				•		Wonil Digital technology Corp.	+82 31 420 5871-3	+82 31 420 5870	jkkim@wonildigital.com
					• Electro-comm	323-254-7790	323-254-8066	dsong@anyeparts.com	
Malaysia			•			Enzer Electronics Sdn, Bhd, K.L.	+60 3 795 54813	+60 3 795 84313	christineml_lai@enzer.com.my
			•			Enzer Electronics Sdn,Bhd, Peneng	+60 4 656 1288	+60 4 656 0288	cl_chee@enzer.com.my
			•		•	Shanhong Electric Pte Limited	+65 6745 8343	+65 6745 8783	ycong@shanhong.com
	•			•		Bluetree Electronics Ltd	+65 6 3482247	+65 6 64555922	rfq@bluetree.com.sg
New Zealand	•					Braemac Pty Limited	+64 9 486 5200	+64 9 486 460	k.ottaway@braemac.com.nz
				•		Eaton Electric	+61 2 9693 9333	+61 2 9667 3702	toryrosa@Eaton.com
				•		Semikron Pty. Limited	+64 9 414 2970	+64 9 414 2971	aaron.murray@semikron.com

IXYS Sales Representatives and Distributors Asia / Pacific / Middle East

Country	Authorized for					Company	Phone	Fax	Email
	IXYS	Westcode	Clare	IXYS RF	MwT				
Singapore				•	•	ANV Trading Company Limited	+66 2 2611688	+66 2 2611689	anvtrading@pacific.net.th
				•		Enzer Electronics Pte. Limited	+65 6 553 0988	+65 6 553 0218	kenny_low@enzer.com.sg
				•		Shanhong Electric Pte Limited	+65 6745 8343	+65 6745 8783	ycong@shanhong.com
				•	•	Bluetree Electronics Ltd	+65 6 3482247	+65 6 64555922	rfq@bluetree.com.sg
South East Asia				•		Anv Trading Co	6622611688	6622611689	anvtrading@pacific.net.th
Taiwan				•		Frontek Technology Corp.	+886 2 8912 1688	+886 2 8912 1396	andy_liu@frontek.com.tw
				•		Neolec International Inc.	+886 2 8751 5852	+886 2 8751 3584	fyih@neolec.com.tw
				•	•	Industrade Company Limited	+886 2 2809 1251	+886 2 2808 4990	info@industrade.com.tw
				•	•	IXYS Taiwan Office	+886 2 2523 6368	+886 2 2523 6369	Sales@ixys.com.tw
				•	•	Seraphim Engineering Company Ltd	+886 2 2698 4660	+886 2 2698 4536	takuyalin@seraphim.com.tw
				•		Sinchtec Company Limited	+886 2 2738 3600	+886 2 2735 1646	sinchtec@ms39.hinet.net
Thailand				•		ANV Trading Company Limited	+662 261 1688	+662 261 1689	anvtrading@pacific.net.th
				•		APT Group Company Limited	+662 757 8222-5	+662 394 1880	aphouse@hotmail.com
				•		Enzer Electr. (Thailand) Comp. Ltd	+662 576 1518	+662 576 1517	jeerapon@enzer.co.th
				•	•	Bluetree Electronics Ltd	+65 6 3482247	+65 6 64555922	rfq@bluetree.com.sg
Middle East	•	•	•	•	•	IXYS Semiconductor GmbH	-	+44 1249 659448	sales.middleeast@ixys.co.uk

IXYS Sales Representatives and Distributors Rest of World

Country	Authorized for					Company	Phone	Fax	Email
	IXYS	Westcode	Clare	IXYS RF	MwT				
Belarus				•		RSP	+7 095 787 6353	+7 095 787 6353	katlerov@rssp.ru
Russia	•	•	•	•	•	Argussoft Electronic Components	+7 495 221 0130	+7 495 221 0137	ixys@argussoft.ru
				•		MT-Systems Limited	+7 812 325 3685	+7 812 786 8579	micro@mtgroup.ru
Ukraine	•	•	•	•	•	SEA Company	+380 44 575 94 00	+380 44 575 9410	aleksandra@sea.com.ua
South Africa				•		Arrow Altech	+27 11 923 9600	+27 11 923 9887	info@arrow.altech.co.za
				•		Avnet Kopp (Pty) Limited	+27 11 809 6100	+27 11 809 6276	sales@avnet.co.za
				•	•	Ecs (Pty) Limited	+27 11 805 4272	+27 11 805 2119	info@ecssa.co.za
				•	•	Advanced Product Techn. (Pty) Ltd	+27 11 792 6583	+27 11 8052119	tony@ecssa.co.za

IXYS Sales Representatives and Distributors Germany

Country	Authorized for					Company	Phone	Fax	Email
	IXYS	Westcode	Clare	IXYS RF	MwT				
Germany Sales Representatives									
South East (D)	•	•	•	•	•	Industrievertretung Reiner Neuf	+49 9356 972020	+49 9356 972121	r.neuf@t-online.de
South West (D)	•	•	•	•	•	Hauber & Graf Electronics	+49 7144 281503	+49 7144 281505	electronics@hauber-graf.de
North West (D)	•	•	•	•	•	Industrievertretung Kraus	+49 2088 833992	+49 2088 833993	p.w.kraus@t-online.de
East (D)	•	•	•	•	•	Power Components	+49 3988 8520015	+49 3988 843071	thomas.kindervater@t-online.de
Central (D)	•	•	•	•	•	Handelsvertretung ELREP	+49 7191 733305	+49 7191 733304	sales@elrep.de
Spare Parts Service	•					IXYS Semiconductor GmbH	+49 6206 503483	+49 6206 503274	w.jaeger@ixys.de
Distributors									
Germany			•			Dacom Sued GmbH	+49 8996 4880	+49 8996 5165	email@dacom-sued.de
		•				Dietrich Schuricht GmbH & Co. KG	+49 1805 2234 35	+49 1805 2234 36	scc@schuricht.de
		•		•		Future Electronics	+49 8995 7270	+49 8995 78838	anita.meisner@futureelectronics.com
		•				Hubert Schroeter	+49 4060 0006-0	+49 4060 0006-30	info@schroeter-kg.de
		•	•	•	•	MJC Elektrotechnik GmbH	+49 6206 15575-0	+49 6206 15670-50	info@mjc-elektrotechnik.de
		•			•	MSC Vertriebs GmbH	+49 7249 910115	+49 7249 910215	wg@msc-ge.com

Europe

Country	Authorized for					Company	Phone	Fax	Email
	IXYS	Westcode	Clare	IXYS RF	MwT				
Austria	•		•	•		ABB Komponenten Div. Industrie	+43 160109 6183	+43 160109 8600	kurt.lechner@at.abb.com
	•		•	•		Future Electronics	+43 2233 55366-0	+43 2233 55360	info-at-future@futureelectronics.com
	•	•		•		IGI Handels GmbH	+43 1699 1636	+43 1699 1638	office@igi.at
	•			•		MSC Vertriebs GmbH	+49 7249 910115	+49 7249 910215	wg@msc-ge.com
					•	MRC Components	+49 816198480	+49 8161984820	info@mrccomponents.de
Belgium			•			ACAL	+32 2 720 59 83	+32 2 725 10 14	jp.cnop@acal.be
	•		•	•		Future Electronics	+32 9340 5270	+32 9340 5270	gino.matthys@futureelectronics.com
	•	•				Promethe Electronics SPRL	+32 71 51 52 80	+32 71 51 99 01	
Bulgaria	•		•	•		Future Electronics	+359 2 9745952	+359 2 9745968	antoaneta.petkova@futureelectronics.com
	•	•	•	•		MJC Elektrotechnik GmbH	+49 6206 15575-0	+49 6206 15670-50	info@mjc-elektrotechnik.de
Czech Rep & Slovakia			•			Enika CZ	+420 49 377 3365	+420 49 377 3322	p.samal@enika.cz
	•		•	•		Future Electronics	+420 72 499 8532	+420 26 121 8842	Pavel.rasejev@futureelectronics.com
	•	•				Starmans Electronics, s.r.o	+420 28 384 2063	+420 28 384 1067	ikolatek@starmans.cz
Denmark	•		•	•		Future Electronics	+45 764 08764	+ 45 764 08765	karl-peter.andersen@futureelectronics.com
	•	•	•	•	•	Trafomo A/S	+45 446 86100	+45 446 86200	trafomo@trafomo.dk
Estonia	•		•	•		Future Electronics Estonia	+372 614 3601	+372 614 3603	janika.metsallik@futureelectronics.com
	•	•		•		Teamtron OY	+358 9 857 1770	+358 9 851 77600	info@teamtron.fi
					•	Avelek Oy	+358 9346 3415	+358 9346 3540	timov.avelek@dlc.fi
				•		Flinkenberg	+358 9 859911	+358 9 85991306	customer.service@flinkenberg.fi
Finland	•	•	•	•		CARO Electronics Ltd	+371 75 01005	+371 75 01004	info@caro.lv
				•		Flinkenberg	+358 9 859911	+358 9 85991306	customer.service@flinkenberg.fi
					•	Avelek Oy	+358 93463415	+358 93463540	timov.avelek@dlc.fi
	•	•	•	•		Future Electronics Finland	+358 9 525 9950	+358 9 455 1050	eero.marttila@futureelectronics.com
Former Yugoslavia/ Croatia/Slovenia/ Bosnia/Serbia	•	•	•	•	•	Teamtron OY	+358 9 857 1770	+358 9 851 77600	info@teamtron.fi
	•	•	•	•	•	Piletic	+385 1 3638 318	+385 1 3639 399	piletic@zg.t-com.hr

IXYS Sales Representatives and Distributors Europe

Country	Authorized for					Company	Phone	Fax	Email
	IXYS	Westcode	Clare	IXYS RF	MwT				
Europe (cont.)									
France	•	•	•	•	•	Arcel	+33 4 78 35 02 21	+33 4 78 35 69 54	diederichs@arcel.fr
						• Elexience	+33 1 69538000	+33 1 60 11 98 09	info@elexience.fr
	•	•	•	•	•	Eurocomposant S.A.	+33 1 30 64 95 15	+33 1 30 43 68 27	vmadeline@eurocomposant.fr
	•	•	•	•	•	Future Electronics	+33 1 69 82 11 11	+33 1 69 82 11 02	patricia.avsec@futureelectronics.com
Greece	•	•	•	•	•	Markides Michelis & Company	+30 210 5980145	+30 210 5909833	sales@markidi.gr
	•	•	•	•	•	Micronics	+30 210 9962948	+30 210 9951814	info@micronics.gr
Hungary	•	•	•	•	•	Future Electronics	+36 1 224 0510	+36 1 224 0511	agnes.morocz@futureelectronics.com
	•	•	•	•	•	MJC Elektrotechnik GmbH	+49 6206 15575-0	+49 6206 15670-50	info@mjc-elektrotechnik.de
Ireland	•	•	•	•	•	Anglia Microwave	+44 1245 227919	+44 1245 227084	sales@anglia-micro.co.uk
	•	•	•	•	•	Future Electronics	+353 162 64098	+353 162 63538	steve.burns@futureelectronics.com
	•	•	•	•	•	Solid State Supplies PLC	+353 673 4455	+353 673 4329	myron.robinson@sssplc.ie
Italy	•	•	•	•	•	CELTE S.R.L.	+39 029 108020	+39 029 210 8088	d.carraro@celte-srl.com
	•	•	•	•	•	Claitron Div. Of Silverstar	+39 026 614 91	+39 026 610 5666	Mguri@arrowitaly.com
	•	•	•	•	•	Enrico Falloni s.r.l.	+39 024 671 2230	+39 0248013233	info@enricofalloni.it
	•	•	•	•	•	FCE	+39 024 892 2329	+39 024 892 2341	giovanni.morelli@FCEdirect.com
	•	•	•	•	•	Future Electronics	+39 026 609 41	+39 026 601 2843	daniela.zanuso@futureelectronics.com
	•	•	•	•	•	Italwest s.r.l.	+39 011 403 3864	+39 011 403 3857	info@italwest.it
Latvia	•	•	•	•	•	CARO Electronics Ltd	+371 75 01005	+371 75 01004	info@caro.lv
Lithuania	•	•	•	•	•	Future Electronics Estonia	+370 37 408482	+370 37 373357	donatas.trapenskas@futureelectronics.com
	•	•	•	•	•	CARO Electronics Ltd	+371 75 01005	+371 75 01004	info@caro.lv
Netherlands	•	•	•	•	•	ACAL, Netherlands	+31 4 0 2502602	+31 40 2510255	acal@acal.nl
	•	•	•	•	•	Future Electronics	+31 76 5444 888	+31 76 5444 880	anne.baeten@future.electronics.com
	•	•	•	•	•	KWx	+31 186 633602	+31 186 633605	halfgeleiders@kwx.nl
Norway	•	•	•	•	•	Future Electronics	+47 2290 5800	+47 2290 5790	erik.dragset@futureelectronics.com
	•	•	•	•	•	Trafomo AB	+45 44 68 61 00	+45 44 68 62 00	Trafomo@trafomo.dk
Poland/Moldavia	•	•	•	•	•	MJC Elektrotechnik GmbH	+49 6206 15575-0	+49 6206 15670-50	info@mjc-elektrotechnik.de
Romania	•	•	•	•	•	Comat ELTH SRL	+40 21 444 1241	+40 21 444 1241	syscom02@as.ro
	•	•	•	•	•	MJC Elektrotechnik GmbH	+49 6206 15575-0	+49 6206 15670-50	info@mjc-elektrotechnik.de
Spain/ Portugal	•	•	•	•	•	ALTAIX ELECTRONICA	+34 91 4400385	+34 91 4400386	javaquero@altaix.com
	•	•	•	•	•	Future Electronics	+34 91 721 4270	+34 91 721 1043	anton.arriaga@futureelectronics.com
	•	•	•	•	•	NEXO Electronica SL	+34 91 375 66 80	+34 91 754 4375	cial@nexosl.com
	•	•	•	•	•	Rectificadores Guasch S.A.	+34 93 309 8891	+34 93 300 1841	guasch@e-guasch.com
Sweden	•	•	•	•	•	Comptronic AB	+46 856 470 670	+46 856 470 671	mailbox@comptronic.se
	•	•	•	•	•	Future Electronics	+46 862 488 00	+46 862 488 90	jan.brandt@futureelectronics.com
	•	•	•	•	•	Trafomo AB	+46 363 895 70	+46 363 895 79	trafomo@trafomo.se
Switzerland	•	•	•	•	•	Novitronic AG	+41 44 306 91 91	+41 44 306 91 81	info@novotronic.ch
	•	•	•	•	•	Powerparts AG	+41 62 896 70 80	+41 62 896 70 88	info@powerparts.ch
Turkey	•	•	•	•	•	Future Electronics	+90 216 571 9700	+90 216 445 8704	bilal.murteza@futureelectronics.com
	•	•	•	•	•	Özdisan Elektronik	+90 216 466 3683	+90 216 466 3686	bilgi@ozdisan.com
United Kingdom	•	•	•	•	•	Anglia Microwave	+44 1245227919	+44 1245227084	sales@anglia-micro.co.uk
	•	•	•	•	•	Europower Components Limited	+44 1427 668888	+44 1427 668866	sales@europowercomponents.com
	•	•	•	•	•	Future Electronics	+44 1753 763000	+44 1753 689100	info-eur-future@futureelectronics.com
	•	•	•	•	•	H-Rep Limited	+44 1249 467403	+44 1249 445306	andy.hurkett@ixys.co.uk
	•	•	•	•	•	GD Rectifiers Limited	+44 1444 243452	+44 1444 870722	enquiries@gdrectifiers.co.uk
	•	•	•	•	•	Harmsworth Townley & Comp. Ltd	+44 1706 814931	+44 1706 812382	sales@townleyltd.co.uk
	•	•	•	•	•	Solid State Supplies PLC	+44 1892 836836	+44 1892 837837	sales@sssplc.com
	•	•	•	•	•	Techrep UK	+44 1823 352572	+44 1823 352797	info@tech-rep.co.uk