

Electrical and Optical Specifications (Ta = 25 °C)

Parameter	Symbol	Min.	Typ.	Max.	Units	Conditions
Photo Current ^a	I _{PH1}	21	30	39	uA	V _{cc} = 1.8V, Lux = 100 ^b
Photo Current ^b	I _{PH2}	—	33	—	uA	V _{cc} = 1.8V, Lux = 100 ^a
Dark Current	I _{DARK}	—	300	—	nA	V _{cc} = 3V, Lux = 0
Light Current Ratio	I _{PH2} / I _{PH1}	—	1.1	—	—	
Rise Time	T _r	—	5	—	ms	R _I = 1K ohm, Lux = 100
Fall Time	T _f	—	5	—	ms	R _I = 1 Kohm, Lux=100
Peak sensitivity wavelength	λ	—	500	—	nm	
Settling Time pulsed at V _{cc}	T _{set}	—	10	—	ms	V _{cc} pulsed = 0V to 3V; R _{load} = 2.4 Kohms; Lux = 100 ^b
Propagation delay	T _d	—	5	—	ms	R _I = 1 Kohm, Lux = 100
Storage delay	T _s	—	5	—	ms	R _I = 1 Kohm, Lux=100
Saturation voltage	V _{sat}	1.0	—	—	V	R _I = 150 Kohm, Lux = 100

a. Illuminance by incandescent lamp

b. White LED is used as a light source

Light Measurement Circuit and Waveforms

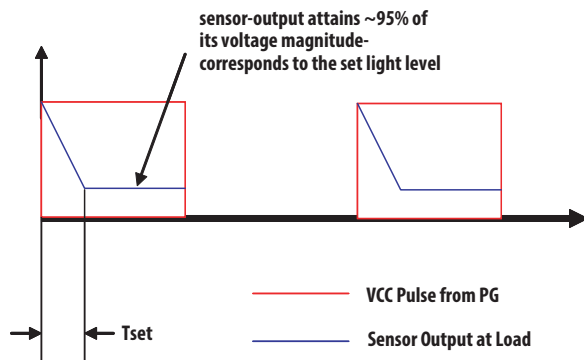
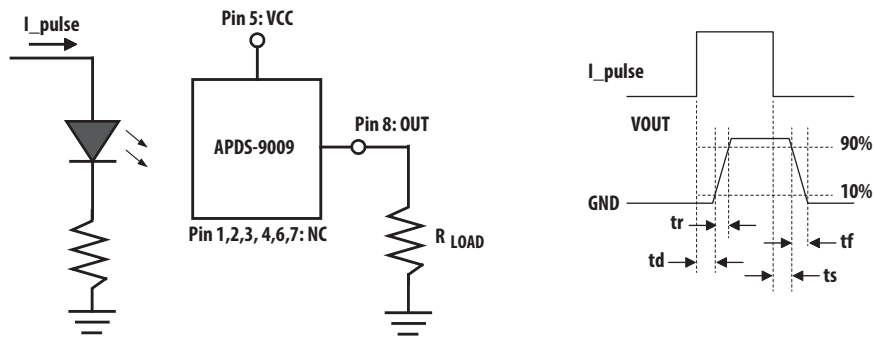

Figure 3 Average IOUT Vs. Lux (Vcc = 1.8V, T=25 °C, White LED Source)

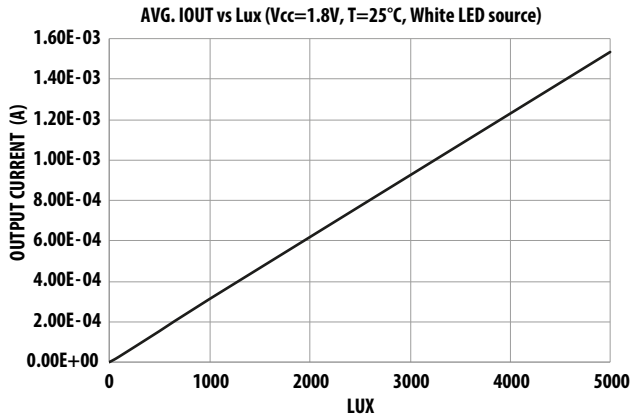

Figure 4 Average relative IOUT Vs. Temp (Vcc = 1.8V, T=25 °C, 100 Lux)

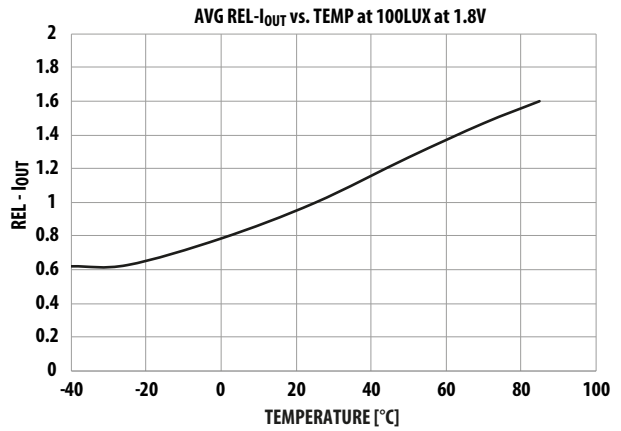

Figure 5 Relative Output Current Vs. Temp (Vcc = 1.8V, 100 Lux)

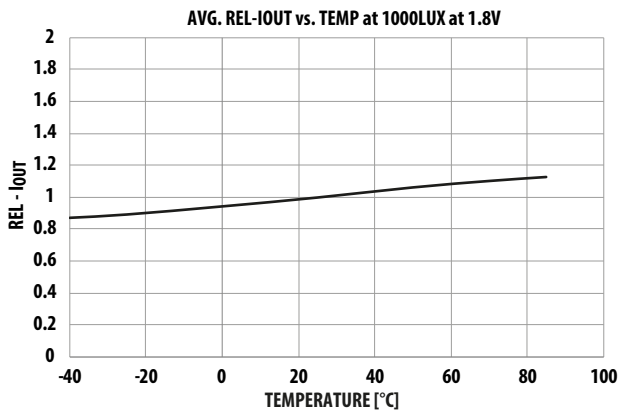

Figure 6 Relative Output Current Vs. Vcc (Ta = 25 °C, 100Lux)

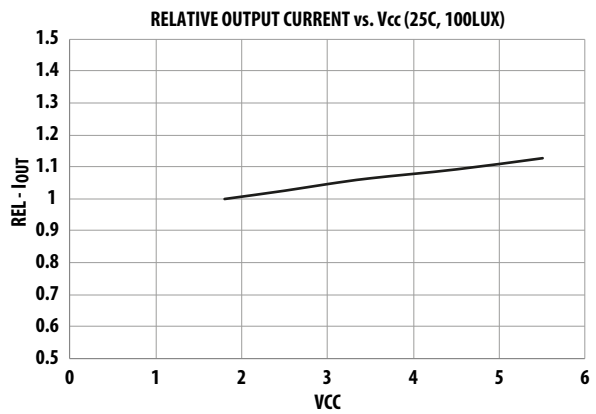

Figure 7 Relative IOUT Vs. Angle (Vcc = 1.8V, Ta = 25 °C)

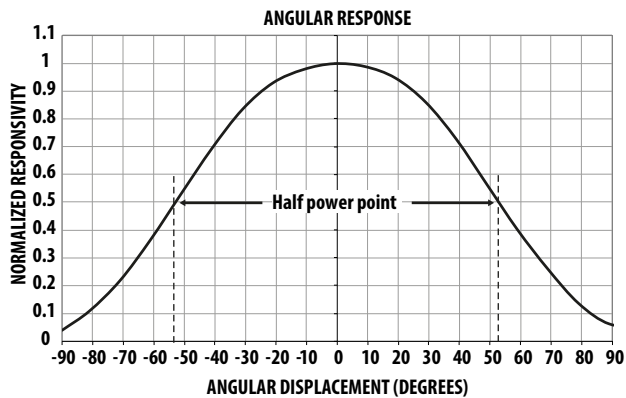

Figure 8 Average Rise Time Vs. Load Resistance at Vcc = 1.8V

