

Product Manual



Servo Positioning Controller ARS-310/5(UL) ARS-310/10

Metronix Meßgeräte und Elektronik GmbH
Kocherstraße 3
D-38120 Braunschweig
Germany

Telefon: +49-(0)531-8668-0
Telefax: +49-(0)531-8668-555
E-mail: vertrieb@metronix.de
<http://www.metronix.de>

metronix

Copyrights

© 2003 Metronix Meßgeräte und Elektronik GmbH. All rights reserved.

The information and data in this document have been composed to the best of our knowledge. However, deviations between the document and the product cannot be excluded entirely. For the devices and the corresponding software in the version handed out to the customer, Metronix guarantees the contractual use in accordance with the user documentation. In the case of serious deviations from the user documentation, Metronix has the right and the obligation to repair, unless it would involve an unreasonable effort. A possible liability does not include deficiencies caused by deviations from the operating conditions intended for the device and described in the user documentation.

Metronix does not guarantee that the products meet the buyer's demands and purposes or that they work together with other products selected by the buyer. Metronix does not assume any liability for damages resulting from the combined use of its products with other products or resulting from improper handling of machines or systems.

Metronix Meßgeräte und Elektronik GmbH reserves the right to modify, amend, or improve the document or the product without prior notification.

This document may, neither entirely nor in part, be reproduced, translated into any other natural or machine-readable language nor transferred to electronic, mechanical, optical or any other kind of data media, without expressive authorisation by the author.

Trademarks

Any product names in this document may be registered trademarks. The sole purpose of any trademarks in this document is the identification of the corresponding products.

Microsoft and Windows are either registered trademarks or trademarks of Microsoft Corporation in the United States and/or other countries.

Revision log			
Author:		Metronix Meßgeräte und Elektronik GmbH	
Manual name:		Product Manual „Servo Positioning Controller ARS-310/5(UL) ARS-310/10“	
File name:		ProductManual_ARS_310_5_10_V2p3.doc	
File location:			
Series no.	Description	Revision index	Date of change
001	Release for distribution	2.0	09.12.2003
002	Numbers of AWG and marks about the (European standard)	2.1	15.01.2004
003	final corrections	2.2	03.02.2004
004	Correction of Windows® Trademark and CPT	2.3	10.01.2005

Table of Contents:

1	GENERAL.....	12
1.1	Documentation	12
1.2	Scope of supply	13
2	SAFETY NOTES FOR ELECTRICAL DRIVES AND CONTROLLERS	14
2.1	Used symbols	14
2.2	General notes	14
2.3	Danger resulting from misuse.....	16
2.4	Safety notes.....	16
2.4.1	General safety notes.....	16
2.4.2	Safety notes for assembly and maintenance	18
2.4.3	Protection against contact with electrical parts	19
2.4.4	Protection against electrical shock by means of protective extra-low voltage (PELV)	20
2.4.5	Protection against dangerous movements.....	21
2.4.6	Protection against contact with hot parts	21
2.4.7	Protection during handling and assembly	22
2.5	Overload behaviour	22
3	PRODUCT DESCRIPTION	23
3.1	General.....	23
3.2	Power supply	25
3.2.1	AC supply	25
3.2.2	Power supply	25
3.2.3	Mains fuse	25
3.3	Brake chopper	25
3.4	Communication interfaces	26
3.4.1	RS232 interface	26
3.4.2	CAN-Bus.....	26
3.4.3	Profibus.....	26
3.4.4	I/O functions and device controller.....	27
4	TECHNICAL DATA	28
4.1	Operating and display elements	29
4.2	Supply [X9]	30
4.3	Motor connection [X6].....	31
4.4	Motor feedback connection [X2]	31

4.4.1	Resolver connection [X2]	32
4.4.2	Encoder connection [X2], [X10], additional 15-pole connector [X21]	32
4.5	Communication interfaces	36
4.5.1	RS232 [X5]	36
4.5.2	CAN bus technology plug-in module	36
4.5.3	Profibus technology plug-in module	37
4.5.4	I/O interface [X1]	38
4.5.5	Incremental encoder input [X10]	39
4.5.6	Incremental encoder output [X11]	39
5	FUNCTION OVERVIEW	40
5.1	Motors	40
5.1.1	Synchronous servo motors	40
5.2	Functions of the servo positioning controller ARS-310/xx	40
5.2.1	Pulse width modulation (PWM)	41
5.2.2	Setpoint management	41
5.2.3	Torque-controlled mode	41
5.2.4	Speed-controlled mode	42
5.2.5	Torque-limited speed control	42
5.2.6	Positioning and position control	42
5.2.7	Synchronization, electrical transmissions	43
5.2.8	Brake management	43
5.3	Positioning control	43
5.3.1	Overview	43
5.3.2	Relative positioning	44
5.3.3	Absolute positioning	44
5.3.4	Driving profile generator	44
5.3.5	Homing	45
6	MECHANICAL INSTALLATION	46
6.1	Important notes	46
6.2	View of the device	48
6.3	Mounting	51
7	ELECTRICAL INSTALLATION	53
7.1	Connector configuration	53
7.2	ARS-310/xx complete system	54
7.3	Connection: Power supply [X9]	56

7.3.1	Device side [X9].....	56
7.3.2	Counterplug [X9].....	56
7.3.3	Pin configuration [X9].....	56
7.3.4	Cable type and design [X9].....	57
7.3.5	Connection notes [X9].....	57
7.4	Connection: external break resistor [X12].....	58
7.5	Connection: Motor [X6].....	58
7.5.1	Device side [X6].....	58
7.5.2	Counterplug [X6].....	58
7.5.3	Pin configuration [X6].....	59
7.5.4	Cable type and design [X6].....	59
7.5.5	Connection notes [X6].....	60
7.6	Connection: I/O communication [X1].....	61
7.6.1	Device side [X1].....	63
7.6.2	Counterplug [X1].....	63
7.6.3	Pin configuration [X1].....	64
7.6.4	Cable type and design [X1].....	65
7.6.5	Connection notes [X1].....	65
7.7	Connection: Resolver [X2].....	66
7.7.1	Device side [X2].....	66
7.7.2	Counterplug [X2].....	66
7.7.3	Pin configuration [X2].....	66
7.7.4	Cable type and design [X2].....	67
7.7.5	Connection notes [X2].....	67
7.8	Connection: Encoder [X2].....	68
7.8.1	Device side [X2].....	68
7.8.2	Counterplug [X2].....	68
7.8.3	Pin configuration [X2].....	68
7.8.4	Cable type and design [X2].....	69
7.8.5	Connection notes [X2].....	70
7.9	Connection: Encoder [X21] (additional 15-pole connector).....	71
7.9.1	Device side [X21] (additional 15-pole connector).....	71
7.9.2	Counterplug [X21] (additional 15-pole connector).....	71
7.9.3	Pin configuration [X21] (additional 15-pole connector).....	71
7.9.4	Cable type and design [X21] additional 15-pole connector.....	73
7.10	Connection: Incremental encoder input [X10].....	75
7.10.1	Device side [X10].....	75
7.10.2	Counterplug [X10].....	75

7.10.3	Pin configuration [X10].....	76
7.10.4	Cable type and design [X10].....	76
7.10.5	Connection notes [X10].....	76
7.11	Connection: Incremental encoder output [X11].....	77
7.11.1	Device side [X11].....	77
7.11.2	Counterplug [X11].....	77
7.11.3	Pin configuration [X11].....	78
7.11.4	Cable type and design [X11].....	78
7.11.5	Connection notes [X11].....	78
7.12	Connection: CAN-Bus Technology Modul	79
7.12.1	Device side as presented by the CAN-Bus Module	79
7.12.2	Counterplug	79
7.12.3	Cable type and design	80
7.12.4	Connection notes	80
7.13	Connection: RS232/COM [X5].....	81
7.13.1	Device side [X5].....	81
7.13.2	Counterplug [X5].....	81
7.13.3	Pin configuration [X5].....	82
7.13.4	Cable type and design [X5].....	82
7.13.5	Connection notes [X5].....	82
8	NOTES ON SAFE AND EMC-COMPLIANT INSTALLATION.....	83
8.1	Definition and terms.....	83
8.2	General information on EMC	83
8.3	EMC areas: first and second environment.....	84
8.4	EMC-compliant cabling.....	84
8.5	Additional EMC equipment for operation with long motor cable	85
8.5.1	Content of the EMC kit.....	86
8.5.2	External Cabling and Assembly	87
8.5.3	Assembly Instructions for the EMC Kit:.....	88
8.5.3.1	Alternative in case of restricted room	89
8.5.4	EMC Kit applications.....	89
8.6	ESD protection	90
9	INITIAL OPERATION	91
9.1	General notes on connection.....	91
9.2	Tools / material	91
9.3	Connecting the motor	91

9.4	Connecting the servo positioning controller ARS-310/xx to the power supply	92
9.5	Connecting the PC	92
9.6	Checking operability	92
10	SERVICE FUNCTIONS AND ERROR MESSAGES	93
10.1	Protection and service functions.....	93
10.1.1	Overview.....	93
10.1.2	Overcurrent and short-circuit monitoring.....	93
10.1.3	Overvoltage monitoring for the DC bus.....	93
10.1.4	Temperature monitoring of the heat sink	94
10.1.5	Monitoring of the motor	94
10.1.6	I ² t monitoring.....	94
10.1.7	Power monitoring for the brake chopper	94
10.1.8	Initial operation status	94
10.2	Display of operating mode and error messages	95
10.2.1	Display of operating mode and errors	95
10.2.2	Error messages.....	95
11	INFORMATION CONCERNING UL.....	99
11.1	Circuit protection.....	99
11.2	Wiring and environment regards.....	99
11.2.1	Motor and mains supply and sensor wiring according to AWG ..	99
11.3	Overload behaviour	99

Table of Figures:

Figure 1:	Type key	23
Figure 2:	Control scheme of the ARS-310/xx	40
Figure 3:	Driving profiles of servo positioning controller ARS-310/xx.....	45
Figure 4:	Servo positioning controller ARS-310/xx: Installation space	47
Figure 5:	Servo positioning controller ARS-310/5 (UL): Front view	48
Figure 6:	Servo positioning controller ARS-310/5 (UL): Top view	49
Figure 7:	Servo positioning controller ARS-310/5 (UL): Bottom view	50
Figure 8:	Servo positioning controller ARS-310/10: Bottom view	51
Figure 9:	Servo positioning controller ARS-310/xx: Mounting plate	52
Figure 10:	Connection to power supply and motor	53
Figure 11:	Complete setup of the ARS-310/xx with motor and PC	55
Figure 12:	Supply [X9] for the servo positioning controller ARS-310/5 (UL)	57
Figure 13:	Supply [X9] for the servo positioning controller ARS-310/10	57
Figure 14:	Motor connection [X6].....	60
Figure 15:	Connecting a holding brake with high current draw (> 0.5A) to the device.....	61
Figure 16:	Basic circuit diagram connector [X1]	62
Figure 17:	Pin configuration: Resolver connection [X2].....	67
Figure 18:	Pin configuration [X2]: In case of the Stegmann (HIPERFACE) encoder evaluation module	70
Figure 19:	Pin configuration [X2]: In case of the Yaskawa (SGM, Sigma 1) Incremental encoder evaluation module.....	70
Figure 20:	Pin configuration X21: Analog incremental encoder –additional 15-pole connector...74	
Figure 21:	Pin configuration X21: Incremental encoder with serial data port (EnDat) –additional 15-pole connector	74
Figure 22:	Pin configuration [X21]: Digital incremental encoder –additional 15-pole connector...75	
Figure 23:	Pin configuration: Input of the incremental encoder [X10].....	77
Figure 24:	Pin configuration: Incremental encoder output [X11]	78
Figure 25:	Pin configuration: CAN-Bus module	79
Figure 26:	Cabling example for CAN-Bus.....	80
Figure 27:	Pin configuration [X5]: RS232 null modem cable	82
Figure 28:	Mechanical installation: EMC kit with three toroidal cores	87
Figure 29:	EMC kit: wiring length of the motor cable	87
Figure 30:	Mechanical dimension of the EMC holding plate	88

Table of Tables:

Table 1:	Scope of supply	13
Table 2:	Connector set: Connector Set 1 and 2	13
Table 3:	Technical data: Ambient conditions and qualification.....	28
Table 4:	Technical specifications: Dimensions and weight	28
Table 5:	Technical specifications: Motor temperature monitoring	28
Table 6:	Technical specifications: Cable specifications	29
Table 7:	Display elements and RESET button	29
Table 8:	Technical specifications: Performance data [X9]	30
Table 9:	Technical specifications: Internal brake resistor [X12]	30
Table 10:	Technical specifications: External brake resistor [X12].....	30
Table 11:	Technical specifications: Motor connection specifications [X6].....	31
Table 12:	Technical specifications: Resolverinterface RDC16N [X2]	32
Table 13:	Technical specifications: Standard incremental encoder with commutation signals ([x2], additional 15-pole connector [X21]).....	33
Table 14:	Technical specifications: high resolution encoder evaluation [X2], additional 15-pole connector [X21].....	35
Table 15:	Technical specifications: RS232 [X5]	36
Table 16:	Technical specifications: CAN bus	36
Table 17:	Technical specifications: Profibus	37
Table 18:	Technical specifications: Digital inputs and outputs [X1].....	38
Table 19:	Technical specifications: analog inputs and outputs [X1].....	38
Table 20:	Technical specifications: Incremental encoder input [X10]	39
Table 21:	Technical specifications: Incremental encoder output [X11].....	39
Table 22:	Pin configuration [X9].....	56
Table 23:	ARS-310/5 (UL) Connector [X12]: External brake resistor.....	58
Table 24:	Pin configuration [X6].....	59
Table 25:	Connector configuration: I/O communication [X1].....	64
Table 26:	Pin configuration [X2].....	66
Table 27:	Pin configuration: Stegmann "HIPERFACE" Encoder evaluation	68
Table 28:	Pin configuration: YASKAWA Incremental encoder [X2].....	69
Table 29:	Pin configuration [X21]: analog incremental encoder – additional 15-pole connector .	71
Table 30:	Pin configuration [X21]: Incremental encoder with serial data port (EnDat) – additional 15-pole connector	72

Table 31:	Pin configuration [X21]: Digital incremental encoder – additional 15-pole connector ..	73
Table 32:	Pin configuration [X10]: Incremental encoder input.....	76
Table 33:	Pin configuration [X11]: Incremental encoder output	78
Table 34:	Pin configuration RS232 interface [X5].....	82
Table 35:	EMC requirements: First and second environment.....	84
Table 36:	content of the EMC kit	86
Tabelle 37:	EMC-Components	89
Table 38:	Display of operating mode and errors	95
Table 39:	Error messages	96

1 General

1.1 Documentation

This product manual serves the purpose of a safe use of the ARS-310/xx series servo positioning controller. It contains safety notes, which must be complied with.

Further information can be found in the following manuals of the ARS-310/xx product range:

❖ **Software Manual WMEMOC 3.5**

”Servo Positioning Controller ARS-310, ARS-560, IMD-310/5F”: Description of the device functionality and the software functions of the firmware including RS232 communication.

Description of the parameterisation program WMEMOC 3.5 GAMMA with instructions on the commissioning of an ARS-310/xx series servo positioning controller.

❖ **CANopen User Manual**: Description of the implemented CANopen protocol as per DSP402.

❖ **PROFIBUS-DP Product manual**: Description of the implemented PROFIBUS-DP protocol.

❖ **Metronix Drive Control (MDC) Programming manual**: This manual contains instructions for all steps necessary to design, produce and test applications based on MDC for the Servo Positioning Controller ARS-310/xx and IMD-F .

1.2 Scope of supply

The scope of supply includes:

Table 1: Scope of supply

1x	Servo positioning controller ARS-310/xx
----	---

Counterplugs for power, controller and shaft encoder connections are not included in the standard scope of supply. They can, however, be ordered as accessories.

Table 2: Connector set: Connector Set 1 and 2

1x	Connector Set 1		Metronix order no.: 9003-0252
	Content:	2x 7-pole PHOENIX connector PC4/7-ST-7,62	
		3x Coding profile	
1x	Connector Set 2		Metronix order no.: 9003-0256
	Content:	2x 7-pole PHOENIX connector PC4/7-ST-7,62	
		3x Coding profile	
		3x 9-pole DSUB connector, male	
		1x 9-pole DSUB connector, female	
		4x DSUB housing for 9-pole DSUB connector	
		1x 25-pole DSUB connector, male	
		1x DSUB housing for 25-pole DSUB connector	

2 Safety notes for electrical drives and controllers

2.1 Used symbols



Information

Important information and notes.



Caution!

Nonobservance may result in severe property damages.



DANGER!

Nonobservance may result in **property damages** and in **personal injuries**.



Caution! Dangerous voltages.

The safety note indicates a possible perilous voltage.

2.2 General notes

In the case of damage resulting from non-compliance of the safety notes in this manual Metronix Meßgeräte und Elektronik GmbH will assume any liability.



Prior to the initial use you must read the chapters *Safety notes for electrical drives and controllers* starting on page 14 and 8 *Notes on safe and EMC-compliant installation* page 83.

If the documentation in the language at hand is not understood accurately, please contact and inform your supplier.

Sound and safe operation of the servo drive controller requires proper and professional transportation, storage, assembly and installation as well as proper operation and maintenance. Only trained and qualified personnel may handle electrical devices:

TRAINED AND QUALIFIED PERSONNEL

in the sense of this product manual or the safety notes on the product itself are persons who are sufficiently familiar with the setup, assembly, commissioning and operation of the product as well as all warnings and precautions as per the instructions in this manual and who are sufficiently qualified in their field of expertise:

- ❖ Education and instruction or authorisation to switch devices/systems on and off and to ground them as per the standards of safety engineering and to efficiently label them as per the job demands.
- ❖ Education and instruction as per the standards of safety engineering regarding the maintenance and use of adequate safety equipment.
- ❖ First aid training.

The following notes must be read prior to the initial operation of the system to prevent personal injuries and/or property damages:



These safety notes must be complied with at all times.



Do not try to install or commission the servo drive controller before carefully reading all safety notes for electrical drives and controllers contained in this document. These safety instructions and all other user notes must be read prior to any work with the servo drive controller.



In case you do not have any user notes for the servo drive controller, please contact your sales representative. Immediately demand these documents to be sent to the person responsible for the safe operation of the servo drive controller.



If you sell, rent and/or otherwise make this device available to others, these safety notes must also be included.



The user must not open the servo drive controller for safety and warranty reasons.



Professional control process design is a prerequisite for sound functioning of the servo drive controller!



DANGER!

Inappropriate handling of the servo drive controller and non-compliance of the warnings as well as inappropriate intervention in the safety features may result in property damage, personal injuries, electric shock or in extreme cases even death.

2.3 Danger resulting from misuse



DANGER!

High electrical voltages and high load currents!

Danger to life or serious personal injury from electrical shock!



DANGER!

High electrical voltage caused by wrong connections!

Danger to life or serious personal injury from electrical shock!



DANGER!

Surfaces of device housing may be hot!

Risk of injury! Risk of burning!



DANGER!

Dangerous movements!

Danger to life, serious personal injury or property damage due to unintentional movements of the motors!

2.4 Safety notes

2.4.1 General safety notes



The servo drive controller corresponds to IP20 class of protection as well as pollution level 1. Make sure that the environment corresponds to this class of protection and pollution level.



Only use replacements parts and accessories approved by the manufacturer.



The devices must be connected to the mains supply as per EN regulations, so that they can be cut off the mains supply by means of corresponding separation devices (e.g. main switch, contactor, power switch).



The servo drive controller may be protected using an AC/DC sensitive 300mA fault current protection switch (RCD = Residual Current protective Device).



Gold contacts or contacts with a high contact pressure should be used to switch the control contacts.



Preventive interference rejection measures should be taken for control panels, such as connecting contactors and relays using RC elements or diodes.



The safety rules and regulations of the country in which the device will be operated must be complied with.



The environment conditions defined in the product documentation must be kept. Safety-critical applications are not allowed, unless specifically approved by the manufacturer.



For notes on installation corresponding to EMC, please refer to *chapter 8 Notes on safe and EMC-compliant installation (page 83)*. The compliance with the limits required by national regulations is the responsibility of the manufacturer of the machine or system.



The technical data and the connection and installation conditions for the servo drive controller are to be found in this product manual and must be met.



DANGER!

The general setup and safety regulations for work on power installations (e.g. DIN, VDE, EN, IEC or other national and international regulations) must be complied with.

Non-compliance may result in death, personal injury or serious property damages.



Without claiming completeness, the following regulations and others apply:

(European standard)

VDE 0100 Regulations for the installation of high voltage (up to 1000 V) devices

EN 60204 Electrical equipment of machines

EN 50178 Electronic equipment for use in power installations

2.4.2 Safety notes for assembly and maintenance

The appropriate DIN, VDE, EN and IEC regulations as well as all national and local safety regulations and rules for the prevention of accidents apply for the assembly and maintenance of the system. The plant engineer or the operator is responsible for compliance with these regulations:



The servo drive controller must only be operated, maintained and/or repaired by personnel trained and qualified for working on or with electrical devices.

Prevention of accidents, injuries and/or damages:



Additionally secure vertical axes against falling down or lowering after the motor has been switched off, e.g. by means of:

- Mechanical locking of the vertical axle,
- External braking, catching or clamping devices or
- Sufficient balancing of the axle.



The motor holding brake supplied by default or an external motor holding brake driven by the drive controller alone is not suitable for personal protection!



Render the electrical equipment voltage-free using the main switch and protect it from being switched on again until the DC bus circuit is discharged, in the case of:

- Maintenance and repair work
- Cleaning
- long machine shutdowns



Prior to carrying out maintenance work make sure that the power supply has been turned off, locked and the DC bus circuit is discharged.



The external or internal brake resistor carries dangerous DC bus voltages during operation of the servo drive controller and up to 5 minutes thereafter. Contact may result in death or serious personal injury.



Be careful during the assembly. During the assembly and also later during operation of the drive, make sure to prevent drill chips, metal dust or assembly parts (screws, nuts, cable sections) from falling into the device.



Also make sure that the external power supply of the controller (24V) is switched off.



The DC bus circuit or the mains supply must always be switched off prior to switching off the 24V controller supply.



Carry out work in the machine area only, if AC and/or DC supplies are switched off. Switched off output stages or controller enablings are no suitable means of locking. In the case of a malfunction the drive may accidentally be put into action.



Initial operation must be carried out with idle motors, to prevent mechanical damages e.g. due to the wrong direction of rotation.



Electronic devices are never fail-safe. It is the user's responsibility, in the case an electrical device fails, to make sure the system is transferred into a secure state.



The servo drive controller and in particular the brake resistor, externally or internally, can assume high temperatures, which may cause serious burns.

2.4.3 Protection against contact with electrical parts

This section only concerns devices and drive components carrying voltages exceeding 50 V. Contact with parts carrying voltages of more than 50 V can be dangerous for people and may cause electrical shock. During operation of electrical devices some parts of these devices will inevitably carry dangerous voltages.



DANGER!

High electrical voltage!

Danger to life, danger due to electrical shock or serious personal injury!

The appropriate DIN, VDE, EN and IEC regulations as well as all national and local safety regulations and rules for the prevention of accidents apply for the assembly and maintenance of the system. The plant engineer or the operator is responsible for compliance with these regulations:



Before switching on the device, install the appropriate covers and protections against accidental contact. Rack-mounted devices must be protected against accidental contact by means of a housing, e.g. a switch cabinet. The regulations VGB4 must be complied with!



Always connect the ground conductor of the electrical equipment and devices securely to the mains supply. Due to the integrated line filter the leakage current exceeds 3.5 mA!



Comply with the minimum copper cross-section for the ground conductor over its entire length as per EN60617!

(European standard)



Prior to the initial operation, even for short measuring or testing purposes, always connect the ground conductor of all electrical devices as per the terminal diagram or connect it to the ground wire. Otherwise the housing may carry high voltages which can cause electrical shock.



Do not touch electrical connections of the components when switched on.



Prior to accessing electrical parts carrying voltages exceeding 50 Volts, disconnect the device from the mains or power supply. Protect it from being switched on again.



For the installation the amount of DC bus voltage must be considered, particularly regarding insulation and protective measures. Ensure proper grounding, wire dimensioning and corresponding short-circuit protection.



The servo drive controllers can carry voltage until up to 5 minutes after being switched off (residual capacitor charge).

2.4.4 Protection against electrical shock by means of protective extra-low voltage (PELV)

All connections and terminals with voltages between 5 and 50 Volts at the servo drive controller are protective extra-low voltage, which are designed safe from contact in correspondence with the following standards:

International: IEC 60364-4-41

European countries within the EU: EN 50178/1998, section 5.2.8.1.



DANGER!

High electrical voltages due to wrong connections!

Danger to life, risk of injury due to electrical shock!

Only devices and electrical components and wires with a protective extra low voltage (PELV) may be connected to connectors and terminals with voltages between 0 to 50 Volts.

Only connect voltages and circuits with protection against dangerous voltages. Such protection may be achieved by means of isolation transformers, safe optocouplers or battery operation.

2.4.5 Protection against dangerous movements

Dangerous movements can be caused by faulty control of connected motors, for different reasons:

- ❖ Improper or faulty wiring or cabling
- ❖ Error in handling of components
- ❖ Error in sensor or transducer
- ❖ Defective or non-EMC-compliant components
- ❖ Error in software in superordinated control system

These errors can occur directly after switching on the device or after an indeterminate time of operation.

The monitors in the drive components for the most part rule out malfunctions in the connected drives. In view of personal protection, particularly the danger of personal injury and/or property damage, this may not be relied on exclusively. Until the built-in monitors come into effect, faulty drive movements must be taken into account; their magnitude depends on the type of control and on the operating state.

	<p>DANGER!</p> <p>Dangerous movements!</p> <p>Danger to life, risk of injury, serious personal injuries or property damage!</p>
--	--

For the reasons mentioned above, personal protection must be ensured by means of monitoring or superordinated measures on the device. These are installed in accordance with the specific data of the system and a danger and error analysis by the manufacturer. The safety regulations applying to the system are also taken into consideration. Random movements or other malfunctions may be caused by switching the safety installations off, by bypassing them or by not activating them.

2.4.6 Protection against contact with hot parts

	<p>DANGER!</p> <p>Housing surfaces may be hot!</p> <p>Risk of injury! Risk of burning!</p>
---	---



Do not touch housing surfaces in the vicinity of heat sources! Danger of burning!



Before accessing devices let them cool down for 10 minutes after switching them off.



Touching hot parts of the equipment such as the housing, which contain heat sinks and resistors, may cause burns!

2.4.7 Protection during handling and assembly

Handling and assembly of certain parts and components in an unsuitable manner may under adverse conditions cause injuries.

	<p>DANGER!</p> <p>Risk of injury due to improper handling!</p> <p>Personal injury due to pinching, shearing, cutting, crushing!</p>
---	--

The following general safety notes apply:



Comply with the general setup and safety regulations on handling and assembly.



Use suitable assembly and transportation devices.



Prevent incarcerations and contusions by means of suitable protective measures.



Use suitable tools only. If specified, use special tools.



Use lifting devices and tools appropriately.



If necessary, use suitable protective equipment (e.g. goggles, protective footwear, protective gloves).



Do not stand underneath hanging loads.



Remove leaking liquids on the floor immediately to prevent slipping.

2.5 Overload behaviour

To ensure the Internal Overload Protection operates at 225% of the Motor Full Load Current after 10 seconds make sure that the motor is properly parameterised according to chapter 5.2.x configuration of motor specification in Software Manual WMEMOC 3.5 "Servo Positioning Controller ARS-310, ARS-560, IMD-310/5 F".

3 Product description

3.1 General

The servo positioning controller ARS-310/xx (ARS servo 1st generation) series devices are intelligent AC servo inverter with substantial parameterisation possibilities and extension options. They are flexible and can be easily adapted to a number of different applications.

The series includes types with single-phase and three-phase supply.

Type key:

Example using the ARS-310/5 (UL)

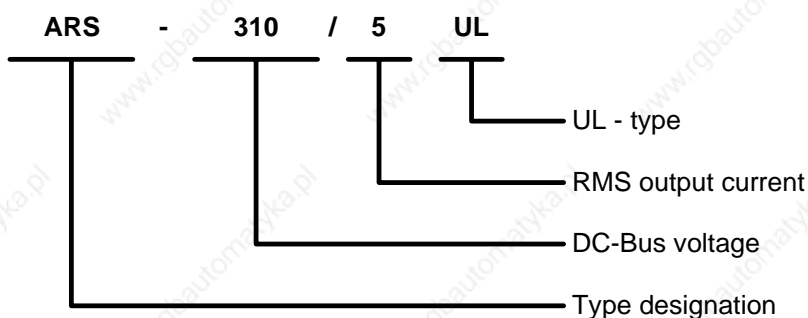

Figure 1: Type key

The single-phase supply type ARS-310/5 (UL) are designed for connection to the 230VAC mains. The servo positioning controller ARS-310/10 is equipped with a symmetrical 3-phase power input, which needs to be connected to a 230VAC 3-phase power supply.

All servo positioning controller ARS-310/xx series devices have the following features:

- ❖ Space-saving compact design, directly cascadable
- ❖ High quality of control due to extremely high-quality sensor technology, far superior to conventional market standards, and better than average computer resources
- ❖ Complete integration of all components for controller and power module including RS232 interface for PC communication, CAN interface for the integration into automation systems
- ❖ Insertabel encoder modules for evaluation for the following encoders:
 - Resolver
 - Incremental encoder with commutation signals

- High-resolution Stegmann incremental encoders, absolute encoders with Hiperface
- High-resolution Heidenhain incremental encoders, absolute encoders with EnDat
- ❖ Compliance with current CE and EN standards without additional external measures
- ❖ UL certification (exclusive for the ARS-310/5 (UL))
- ❖ Completely closed, EMC-optimized metal housing for mounting to conventional control cabinet plates. All devices comply with the IP20 system of protection.
- ❖ Integration of all filters to fulfill the EMC regulations (industrial) inside the device, e.g. line filter, motor output filter, filter for 24V-supply as well as inputs and outputs
- ❖ Integrated brake resistor. External resistors can be connected to the ARS-310/5 (UL) for higher braking energies.
- ❖ Complete galvanic separation of controller and power output stage as per EN50178. Galvanic separation of the 24V potential area with the digital inputs and outputs, analog electronics and the controller electronics.
- ❖ Operation as speed controller, torque controller or positioning controller
- ❖ Integrated positioning control with wide range of functions as per CAN in Automation (CiA) DSP402 and numerous additional application-specific functions
- ❖ Jerk limit or time-optimal positioning relative or absolute to a point of reference
- ❖ Point-to-point positioning with or without active positioning profile
- ❖ Speed and angle synchronisation with electronic gear system via incremental encoder input
- ❖ Extensive modes of operation for synchronisation
- ❖ Various methods for homing
- ❖ Short cycle times, bandwidth in current control circuit ca. 2 kHz, in speed control circuit ca. 500Hz.
- ❖ Integrated soft PLC with MDC (**M**etronix **D**rive **C**ontrol) for customized function changes and extensions
- ❖ Freely programmable I/O's
- ❖ User-friendly parameterisation with the parameterising tool WMemoc
- ❖ Menu-driven first set up
- ❖ Automatic motor identification
- ❖ Easy coupling to host controller, e.g. to a PLC via I/O level or fieldbus
- ❖ Technology slot for extensions, e.g. a fieldbus interface

3.2 Power supply

3.2.1 AC supply

3.2.2 Power supply

In Opposite to the supply of the servo positioning controller of the ARS-310/5 (UL) which is done by a single phase 230VAC supply, the ARS-310/10 needs to be connected to a symmetrical 230VAC supply. Alternatively the ARS-310/xx can be supplied by use of the DC bus connections ZK+ and ZK- connected to 320VDC. Enlargement of the output power of the ARS-310/xx can be achieved by DC-Bus supply. The output power raises from 1kVA to 1.5kVA for the ARS-310/5 (UL). The ARS-310/10 has a power increase from 2.5kVA to 3kVA.



The ARS-310/10 needs to have a 3-phase **230VAC** supply, which is not equal to the 3-phase 400VAC supply

The DC bus coupling improves the load characteristic on big loads because it ensures an equal power distribution between the different servo positioning controller.



If DC bus coupling is taken into account, please refer to application note 67 or contact the manufacturer!

3.2.3 Mains fuse

Depending of the type of the servo positioning controller ARS-310/xx, a single phase (ARS-310/5 (UL)) or a 3 phase (ARS-310/10) mains fuse with 16A and slow characteristic (B16) is necessary.

3.3 Brake chopper

A brake chopper with a brake resistor is integrated into the power output stage. If during the generator operation the permissible charging capacity of the DC bus is exceeded, the braking energy can be converted into heat by the internal braking resistor. The brake chopper is software-driven. The internal braking resistor is overload-protected by means of software and hardware.

If in a special application the power of the internal resistors should be insufficient, they can be cut off by removing the bridge between the pin *RB-* and *RBI* of the [X12] plug. Instead, an external brake resistor is inserted between the pins *RB-* and *RB+*. This brake resistor must fulfill certain minimum specifications (see *Table 10, page 30*). The output is protected against short-circuiting in the brake resistor or its cable.

Pin *RB+* lies on positive DC bus potential and is thus not protected against ground fault or short-circuits against mains voltage or negative DC bus voltages.

Simultaneous use of the internal and external brake resistors is not possible. The external resistors are not automatically overload-protected by the device.

Excel calculation sheets for the selection of an external brake resistor can be received from the manufacturer.

3.4 Communication interfaces

The servo positioning controller ARS-310/xx has several communication interfaces. The device comprises a RS232 interface, which is crucial for the connection via PC and for using the parameterization tool WMEMOC.

As an enlargement, the servo positioning controller ARS-310/xx also features a CANopen and a PROFIBUS-DP interface. CANopen and PROFIBUS-DP plug-in modules can be used as extension option's.

Customized fieldbus protocols can be realized, if necessary.

In any case, the servo positioning controller of this design always works as a slave to the fieldbus.

3.4.1 RS232 interface

The RS232 protocol is mainly intended to be a parameterization interface, but also allows the control of the servo positioning controller.

3.4.2 CAN-Bus

The CANopen protocol as per DS301 with application profile DSP402 is implemented.

3.4.3 Profibus

Support of Profibus communication as by the Metronix telegram is given. To fulfill drive applications, a set of modules (Function Block) for the Siemens S7 PLC are placed for disposal. The modules handle speed- torque- and position - control.

3.4.4 I/O functions and device controller

Ten digital inputs provide the elementary control functions (see *chapter 4.5.4 I/O interface [X1], page 38*):

The ARS-310/xx comprises a target table, in which the positioning targets are stored and from which they can later be retrieved. Four digital inputs serve the purpose of target selection; one input is used as a start input. The limit switches serve the safety limitation of the motion space. During a homing one of the two limit switches may serve as a reference point for the positioning control.

Two inputs are used for the power stage enabling on the hardware side as well as for the controller enabling on the software side.

High-speed sample inputs are available for different time-critical applications (homing, special applications...). The servo positioning controller ARS-310/xx has two analog inputs for input levels in the range of $+10V$ to $-10V$. The differential inputs guarantee high interference immunity. The analog signals are quantified and digitized by an analog-digital converter at a resolution of 10 bit. The analog signals provide the setpoints (speed or torque) for the control.

4 Technical data

Table 3: Technical data: Ambient conditions and qualification

Range	Value
Admissible temperature ranges	Storage temperature: -25°C to +60°C
	Operating temperature: 0°C to +40°C +40°C to +50°C at reduced power
Admissible installation height	Up to 1000 m above msl, 1000 to 4000 m above msl at reduced power
Humidity	Relative humidity up to 90%, not bedewing
Protection class	IP20
Pollution degree	1
CE conformity Low-voltage directive: EMC regulation:	EN 50 178 EN 61 800 – 3 (European standard)
Listings	UL508C and cUL508C (only ARS-310/5 (UL))

Table 4: Technical specifications: Dimensions and weight

Type	ARS-310/5 (UL)	ARS-310/10
Dimensions H*W*D	215*70*215 mm	230*70*215 mm
Dimensions of the mounting plate	240*32*3 mm	
Weight	2,8 kg	

Table 5: Technical specifications: Motor temperature monitoring

Motor temperature monitoring	Range
Digital sensor	Normally closed contact: $R_{cold} < 500 \Omega$, $R_{hot} > 100 k\Omega$ (configurable as normally open contact if necessary)



The wiring of the motor temperature need to be done in accordance to the regards of EN50178 as far as galvanic separation between controller and main supply is concerned.

Table 6: Technical specifications: Cable specifications

Range	ARS-310/5 (UL)	ARS-310/10
Maximum motor cable length for interference emission as per EN 61800-3 (corresponds to EN 55011, EN 55022)		
Second ambient (industrial area)	$l \leq 10\text{m}$	$l \leq 10\text{m}$
Second ambient (industrial area) (see chapter 8 Notes on safe and EMC-compliant installation)	$l \leq 40\text{m}$	$l \leq 40\text{m}$
Cable capacity of a phase against shield or between two lines	$C' \leq 250\text{pF/m}^{1)}$	



1) The internal filter is made for a maximum cable capacity $C_{\text{cabel}} = l \times C$, which is equal to $C_{\text{cabel}} = 10\text{nF}$.

In the case of 50m cable length, a cable capacity of $C' < 200\text{pF/m}$ is desired

4.1 Operating and display elements

On the front the servo positioning controller ARS-310/xx has a LED and one seven-segment display to indicate the operating status.

Table 7: Display elements and RESET button

Element	Function
Seven-segment display	Display of operating mode and a coded error number in the case of a malfunction
LED	Operational state
RESET-Button	Hardware reset for processor

4.2 Supply [X9]

Table 8: Technical specifications: Performance data [X9]

Type	ARS-310/5 (UL)	ARS-310/10
Supply voltage	1 x 230 VAC [-30% + 10%]	3 x 230 VAC [-30% + 10%]
Alternative DC supply	20 .. 350 VDC	20 .. 350 VDC
24V supply	24 VDC [\pm 20%] (0,35 A) *	24 VDC [\pm 20%] (0,35 A) *

*) plus current consumption of a possibly connected holding brake and I/Os

Table 9: Technical specifications: Internal brake resistor [X12]

Type	ARS-310/5 (UL)	ARS-310/10
Brake resistance internal	approx. 175 Ω	33 Ω
Pulse power	1 kW	4 kW
Continuous power	25 W	40 W
Threshold limit	385 V	385 V

Table 10: Technical specifications: External brake resistor [X12]

Type	ARS-310/5 (UL)	ARS-310/10
Brake resistance external	\geq 50 Ω	no support for external brake resistor. (Please contact manufacturer)
Continuous power	\leq 1000 W	
Operating voltage	\geq 400 V	

4.3 Motor connection [X6]

Table 11: Technical specifications: Motor connection specifications [X6]

Type	ARS-310/5 (UL)	ARS-310/10
Specifications for operation with 1x 230 VAC 50 Hz (or 3x 230 VAC 50 Hz for ARS-310/10)		
Output power	1 kVA	2,5 kVA
Output power in case of DC bus supply	1,5 kVA	3 kVA
Max. output power for 2 s	3 kVA	6 kVA
Output current	5 A _{RMS}	10 A _{RMS}
Max. output current for 3 s	10 A _{RMS}	20 A _{RMS}
Clock frequency	10 kHz	10 kHz

4.4 Motor feedback connection [X2]

Different feedback systems can be connected to the servo positioning controller ARS-310/xx via the universal encoder interface:

- ❖ Resolver (interface [X2])
- ❖ Encoder (interface [X2], additional 15-pole DSUB connector)
 - Incremental encoder (YASKAWA)
 - SinCos encoder (single-turn/multi-turn) with HIPERFACE
 - SinCoder with HIPERFACE
 - Multiturn absolute encoder with EnDat
 - Analog Heidenhain encoder

The type of the encoder interface module of the servo positioning controller ARS-310/xx is equipped by the manufacturer.

The feedback signal is available via the incremental encoder output [X11] for master-slave application. The resolution of the encoder output [X11] is dependent of the plugged encoder evaluation module. The default resolution is 1024 lines per revolution.

It is possible to evaluate two shaft encoder systems in parallel. Typically, the resolver for the current control is connected to [X2], and e.g. an encoder is connected to [X11] as a feedback system for the positioning control.

4.4.1 Resolver connection [X2]

Common resolvers are evaluated at the 9-pole D-Sub connector [X2]. Single-pole resolvers are supported.

The resolver offset angle, which is determined automatically during the identification, is readable and writeable for service purposes.

Table 12: Technical specifications: Resolverinterface RDC16N [X2]

Parameter	Value
Resolution	16 Bit
Speed resolution	ca. 4 min ⁻¹
Absolute accuracy of angle detection	< 5'
Max. rotational speed	16.000 min ⁻¹
encoder output	
lines per revolution	programmable 1 – 16384
output	A, B, Index
output level	differential / RS422
maximum output frequency	312kHz (lines per sec)

4.4.2 Encoder connection [X2], [X10], additional 15-pole connector [X21]

At the input [X2], [X10] and at the 15-pole DSUB connection [X21], motors with encoder can be fed back. The possible incremental encoders for the encoder connection are divided into several groups. Dependent of the application and the use of an absolute encoder it is possible to get rid of the so called homing run at switch on of the servo positioning controller.

If you want to use other types of encoder, please contact your sales representative.

Standard incremental encoders without commutation signals (connector [X10]):

This type of encoder is used as an additional second encoder to enlarge the positioning resolution of the workpiece. It is not possible to drive a motor with an encoder connected to this input of the servo positioning controller ARS-310/xx.

Standard incremental encoders with commutation signals (additional 15-pole connector [X21])

These are standard incremental encoders with three binary hall sensor signals. The number of lines of the encoder can be freely parameterized (16 – 9192 lines/rotation).

There is an additional offset angle for the hall sensor signals. It is determined during motor identification or can be set via the parameterization software. In general, the hall sensor offset angle is zero.

Incremental encoders used with the YASKAWA SGM motors with Sigma 1 interface (connector [X2])

In this variation of a standard incremental encoders hall signal information is coded into the index pulse. The number of lines of the encoder is limited to 1024, 2048 or 8192 lines/rotation.

There is no angle identification necessary.

Table 13: Technical specifications: Standard incremental encoder with commutation signals ([x2], additional 15-pole connector [X21])

Parameter	YASKAWA (SGM motor) (connector [X2])	Incremental encoder with commutation signals (additional. 15-pole connector [X21])
Parameterisable number of encoder lines	1024, 2048, 8192 lines/rev (dependent from the encoder type)	adjustable: 16 – 8192 lines/rev
Angular resolution	12, 13, 15 Bit/rev	adjustable: (dependent from the encoder type)
Encoder signals A, B	differentiell; RS 422	
Encoder signal N	differentiell; RS 422	
Commutation track	coded in Index-pulse (RS422)	Hall-inputs (TTL – level)
Input impedance encoder signals A, B, N	Differential input 120 Ω	
maximum input frequency	>600kHz	
Output supply	5 V; max. 150 mA; current-limited control via sensor lines	
Incremental encoder output		
Number of lines	Programmable 1 – number of encoder lines	
Connection level	Differential / RS422 specification	
Encoder signals A, B, N	As per RS422 specification	
Limit frequency	$f_{Limit} > 600kHz$ (lines/s)	

Stegmann encoders [X2]:

Single-turn and multi-turn shaft encoders with HIPERFACE made by Stegmann are supported. To support Stegmann encoder with the servo positioning controller the Hiperface encoder module needs to be plugged. The following series of encoders can be connected:

- ❖ Single-turn SinCos encoders: SCS 60, SCS 70, SR 50, SR 60
- ❖ Multi-turn SinCos encoders: SRM 50, SRM 60, SCM 60, SCM 70
- ❖ SinCoder encoders: SNS 50, SNS 60
- ❖ SinCos encoders for hollow-shaft motor drives: SCS-Kit 101, SCM-Kit 101, SHS 170

Analog Heidenhain encoders (additional 15-pole connector [X21]):

Incremental analog encoders by Heidenhain which support the Z0 and Z1 line are evaluated. To evaluate analog Heidenhain encoders, the Heidenhain encoder module must be plugged in. The following series of encoders can be connected:

- ❖ Heidenhain ERN1085, ERN1085, ERN 1387,

Heidenhain encoders with EnDat and Z0 (additional 15-pole connector [X21]):

Incremental analogue encoders by Heidenhain which support the Z0 line and the digital EnDat can be evaluated. If encoders with EnDat-interface are used the connection to multiturn absolute encoders is also possible.

- ❖ Heidenhain encoder with EnDat-interface: ECN413, ECN1313, EQN 425, ECN1113, ECN1313, EQN1125, EQN1325,
- ❖ ECI 1317, EQI1329 (new low-cost series with magnetic sensors (32 lines per revolution)).

It must be taken into account that in case of having an EnDat encoder the so called EnDat module needs to be used for evaluation of the encoder output. Furthermore a special firmware must be loaded. Please refer to your sales partner.

Table 14: Technical specifications: high resolution encoder evaluation [X2], additional 15-pole connector [X21]

Parameter	Stegmann HIPERFACE (connector [X2])	Heidenhain (additional. 15-pole connector [X21])
Changeable number of encoder lines	till 1024 (dependent from the encoder type)	1 – 16384 lines/rev
Angular resolution	18 Bit/rev	>18 Bit/rev (dependent from the encoder type)
Interpolation	8 Bit	9 Bit
Encoder signals A, B	1V _{ss} differential 2,5V offset	
Encoder signal N	1V _{ss} differential 2,5V offset	
Commutation track A1, B1		1V _{ss} differential 2,5V offset (only for analog Heidenhain encoder)
Input impedance encoder signals A, B, N	Differential input 120 Ω	
maximum input frequency	f _{limit} > 100kHz (high resolution signal)	f _{limit} > 300kHz (high resolution signal)
Additional data port	HIPERFACE (Stegmann)	EnDat (Heidenhain) (only EnDat encoder modul)
Output supply	12 V; max. 200 mA; current-limited control via sensor lines	5 V; max. 250 mA; current-limited control via sensor lines
Incremental encoder output		
Number of lines	number of encoder lines	Programmable 1 – 16384 lines
Output	A,B, Index	
Output level	differential, As per RS422 specification	
Limit frequency	102kHz (equal to 1024 lines/s)	312kHz (lines per rev)

4.5 Communication interfaces

4.5.1 RS232 [X5]

The serial interface is build in accordance to the RS 232 specification and it is provided to configure the ARS. The parameterization is done by use of the parameterization program WMEMOC (for *Windows®*).

In applications with no need for high data transfer rates and no network integration, the RS-232 can also be used for control of the servo positioning controller.

Table 15: Technical specifications: RS232 [X5]

Communication interfaces	Value
RS232	As per RS232 specification, 9600 Baud to 57,6kBaud

4.5.2 CAN bus technology plug-in module

The CAN interface for the ARS or IMD-F technology extension slot offers an inexpensive and fast field bus connection. The ARS version also provides eight additional digital inputs and outputs each.

The ADU16 module differs from the CAN bus module in the additional 16-Bit analog input port instead of the 8 digital outputs.

Table 16: Technical specifications: CAN bus

Communication interfaces	CAN-modul	ADU-16 modul
CAN controller	ISODIS 11898, full CAN controller, max. 1Mbaud	
CAN protocol	CANopen as per DS301 and DS402	
Additional features		
Digital inputs (number/level)	8 / (12-24V)	
Digital outputs	8 (24V; 100mA; external supplied)	-
Analog inputs	-	16 Bit / differential; +10 V

4.5.3 Profibus technology plug-in module

The PROFIBUS-DP interface for the ARS technology extension slot offers a further field bus connection in addition to the CAN module. All functions and parameters can be directly addressed, e.g. by means of a Simatic S7 control.

As a special feature, S7 functional blocks were developed for the servo controllers. By means of these units the user can manage the drive controllers directly from the PLC program, thereby providing an easy integration into the world of the Simatic S7.

Table 17: Technical specifications: Profibus

Communication interfaces	Profibus-modul
Controller	Profibus controller VPC3+, max. 12Mbaud
Protocol	PROFIBUS-DP, 32 Byte telegram with operating mode dependent assembly
Interface	optoisolated, 9-pole DSUB, integrated termination resistors
specific features	Support of diagnostic information, separate connectable RTS-signal, fail safe mode, sync/freeze

4.5.4 I/O interface [X1]

Table 18: Technical specifications: Digital inputs and outputs [X1]

Inputs/outputs	Specifications	
Signal level	24V (12V...30V) active high, conforming with EN 1131-2	
Logic inputs general	Bit 0 \ Bit 1, \ Target selection for positioning Bit 2, / 16 targets selectable from target table Bit 3 /	
DIN4	Control input stage enable at High	
DIN5	Controller enable at High, clear error high-low transition at Low	
DIN6	End switch input 0	
DIN7	End switch input 1	
DIN8	Control signal Start positioning	
DIN9	Home switch for homing or saving of positions	
Logic outputs general	Galvanically separated, 24V active high	
DOUT0	Operational state	24 V, max. 100 mA
DOUT1	Freely configurable	24 V, max. 100 mA
DOUT2	Freely configurable	24 V, max. 100 mA
DOUT3	Freely configurable	24 V, max. 100 mA
DOUT4 [X6]	Holding brake adjustable for vertical axis movement additional voltage loss nearly 1.5V	24 V, max. 500mA

Table 19: Technical specifications: analog inputs and outputs [X1]

Analog in-/outputs	Values
Analog input: AIN0	$\pm 10V$ input range, 10 Bit, differentially, $< 250\mu s$ delay time Impedance $R_i = 20k\Omega$
Analog input: AIN1	
Analog outputs: AOUT0 and AOUT1	$\pm 10V$ output range, 8 bit resolution, $f_{Limit} > 1kHz$

4.5.5 Incremental encoder input [X10]

The input supports all common incremental encoders.

For example encoders corresponding to the industry standard ROD426 by Heidenhain or encoders with single-ended TTL outputs as well as open collector outputs.

Table 20: Technical specifications: Incremental encoder input [X10]

Parameter	Value
Trace signals A, #A, B, #B, N, #N	As per RS422 specification
Max. input frequency	500 kHz
Output supply	5 V; max. 100 mA

4.5.6 Incremental encoder output [X11]

The output provides incremental encoder signals for processing in superimposed controls.

The signals are generated from the encoder's angle of rotation with a freely programmable number of lines.

Besides the encoder signals A and B, the emulation also provides a reset pulse, which goes to high once per rotation (for the programmed number of lines), for the duration of a $\frac{1}{4}$ signal period (as long as the encoder signals A and B are high).

Table 21: Technical specifications: Incremental encoder output [X11]

Parameter	Value
Number of lines	Programmable but dependent from the encoder module
Connection level	Differential / RS422 specification
Encoder signals A, B, N	As per RS422 specification
Limit frequency	dependent from the encoder module
Output supply	5 V, max. 100 mA

5 Function overview

5.1 Motors

5.1.1 Synchronous servo motors

Typically, permanently excited synchronous motors with sinusoidal EMF are used. The servo positioning controller ARS-310/xx is a universal servo drive controller, which can be operated with standard servo motors. The motor specifications are determined and parameterized by means of an automatic motor identification.

5.2 Functions of the servo positioning controller ARS-310/xx

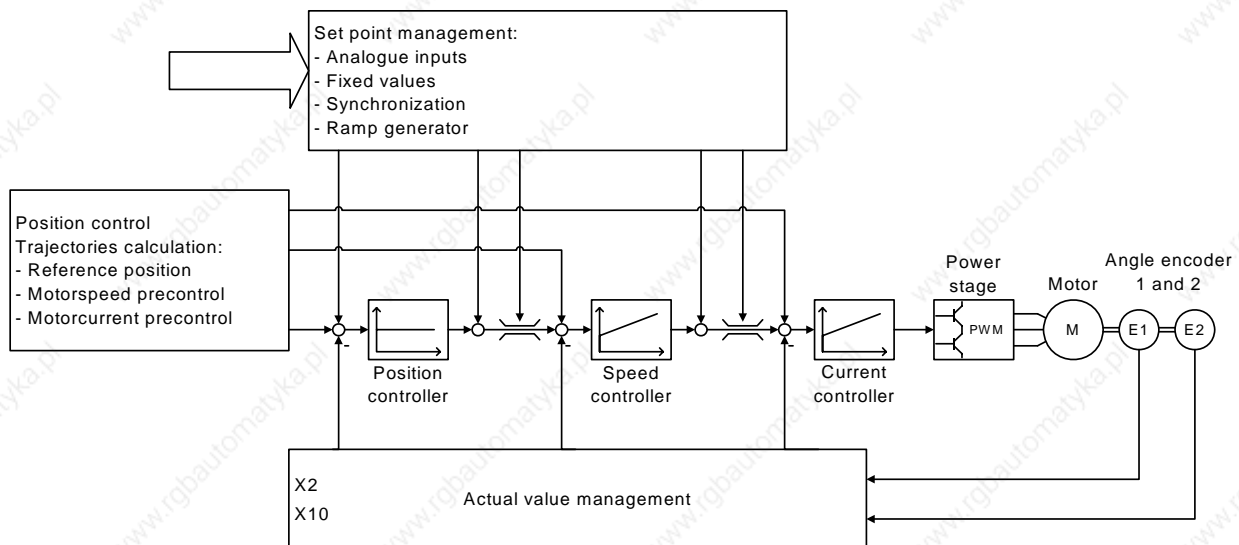

Figure 2: Control scheme of the ARS-310/xx

Figure 2 shows the basic control structure of the ARS-310/xx. Current controller, speed controller and positioning controller are arranged in a cascade. Due to the rotor-oriented control principle the current can be set separated in active current (i_q) and reactive current (i_d). Therefore there are two current controllers, both of them PI controllers. To provide a better overview, however, the i_d controller does not appear in Figure 2.

The basic modes of operation are torque control, speed control with torque limitation and positioning. Functions such as synchronization, „flying saw“, etc. are variants of these basic modes of operation.

5.2.1 Pulse width modulation (PWM)

The servo positioning controller ARS-310/xx features a sine modulation or alternatively a sine modulation with third harmonic. This increases the effective converter output voltage. The type of modulation can be selected via the WMEMOC. The default setting is sine modulation.

5.2.2 Setpoint management

For speed controlled and torque controlled modes of operation, the setpoint can be set via a setpoint management.

Possible setpoint sources are:

- ❖ 3 analog inputs:
 - AIN 0, AIN 1 and AIN 2 (16-bit analog input provided by the ADU16 modul)
- ❖ fixed values:
 - value: setting depending on controller enabling logic:
 - RS232 interface or
 - CANopen bus interface or
 - PROFIBUS-DP interface or
- ❖ Additional incremental encoder input [X10]



If no setpoint source is activated, the setpoint is zero.

The setpoint management has a ramp generator with a preceding adder. Any of the above-mentioned setpoint sources can be selected via the corresponding selectors and run through the ramp generator. Additional sources can be selected as setpoints using the second selector. These, however, cannot be run through the ramp generator. The total setpoint is then a summation of both values. The acceleration and deceleration times of the ramp are directionally changeable

5.2.3 Torque-controlled mode

In torque control mode a certain setpoint torque is set, which the servo positioning controller generates in the motor. In this case only the current controller is activated, since the torque is proportional to the motor current.

5.2.4 Speed-controlled mode

This mode of operation is used, if the motor speed is to be kept constant regardless of the acting load. The motor speed exactly follows the speed set by the setpoint management.

The cycle time of the speed control loop for the servo positioning controller ARS-310/xx is twice the PWM period duration, thus typically 200µs.

The speed controller is a PI controller. In order to eliminate wind-up effects, the integrator function is stopped upon reaching subsidiary limitations.

In speed control mode the current controllers and the speed controller are active.

The setpoints of the speed as well as the actual position are generally determined from the encoder system inside the motor, which is also used for commutation. For the actual value feedback to the speed control the X2 encoder interface (additional X21 connector) is selected. The actual speed value for the speed controller is always fed back via the commutation encoder e. g. resolver input.

The setpoint for the speed can also be set internally or can be derived from the data of an external encoder system (speed synchronization via [X10] for speed controller).

It is also possible to use values set in a MDC program (**Metronix Drive Control**).

5.2.5 Torque-limited speed control

The servo positioning controllers ARS-310/xx support torque-limited speed-controlled operation with the following features:

- ❖ Fast updating of the limit value, e.g. in 200 µs cycle

5.2.6 Positioning and position control

In positioning mode a superordinated positioning controller is active in addition to the speed control, which processes deviation of the actual position from the set position and converts it into the corresponding setpoints for the speed controller.

The cycle time of the positioning cycle is by default twice the speed controller cycle time and can be read from the parameterization software WMEMOC. The position controller is configured as a P controller.

When the positioning controller is activated, it receives its setpoints from the positioning or from the synchronization controller. The internal resolution is 16 or 18 bits per motor revolution (depending on the used encoder).

The setpoint management also allows the setting of setpoints in MDC programs.

5.2.7 Synchronization, electrical transmissions

The servo positioning controller ARS-310/xx allows master-slave operation, which in the following will be called synchronization. The controller can serve as master or slave.

If the servo positioning controller ARS-310/xx is the master, it can provide the slave with its current rotor position at the incremental encoder output [X11]. If the ARS-310/xx controller comprises a communication interface, it can as a master optionally transmit either its current position, speed or both values.

If the servo positioning controller ARS-310/xx is to work as a slave, different inputs are available for synchronization. An incremental encoder (position synchronization via [X10] with speed feed forward for the speed controller) or the communication interface can be used as inputs. The speed feed forward can be calculated by the servo positioning controller ARS-310/xx itself. All inputs can be activated/deactivated. The internal encoder can optionally be shut off, if another input is selected as setpoint encoder. This also applies for speed control mode. The external inputs can be weighed with transmission factors. The different inputs can be used individually or simultaneously and can be read out via a fieldbus.

5.2.8 Brake management

The servo positioning controller ARS-310/xx can directly actuate a holding brake. The holding brake is operated with programmable delay times.

In positioning mode an additional automatic braking function can be activated, which shuts down the power stage of the ARS-310/xx after a parameterized idle time and which lets the brake fall in.

5.3 Positioning control

5.3.1 Overview

In positioning mode a certain position is set, which is to be approached by the motor. The current position is derived from the information provided by the internal encoder evaluation. The position deviation is processed in the position controller and is passed on to the speed controller.

The integrated positioning control allows jerk-limited or time-optimal positioning relative or absolute to a point of reference. It provides the position controller and - to improve the dynamics - the speed controller also, with the setpoints.

In the case of absolute positioning a set target position is directly approached. In the case of relative positioning a parameterized route is run. The positioning space of 2^{16} full revolutions allows any number of relative positioning in one direction.

The positioning control is parameterized via a target table. This includes entries for the parameterization of a target via a communication interface and also target positions, which can be retrieved via the digital inputs. For each entry it is possible to set the positioning method, the driving profile, the acceleration and the deceleration times as well as the maximum speed. All targets can be

pre-parameterized. The only thing to do for positioning is then to select an entry and start the action. It is also possible to change the target parameters online via the communication interface.

The servo positioning controller ARS-310/xx provides 16 programmable positioning sets.

The following settings are possible for all positioning sets:

- ❖ Target position (Destination)
- ❖ Driving speed (Running speed)
- ❖ Final speed
- ❖ Acceleration
- ❖ Deceleration
- ❖ Torque feed forward
- ❖ Remaining distance trigger
- ❖ Remaining time trigger
- ❖ Additional flags:
 - Relative / relative to last target / absolute
 - Wait for end / interrupt / ignore start
 - Synchronized

5.3.2 Relative positioning

In the case of relative positioning, the target position is added to the current position. Since no fixed zero is required, referencing is not compulsory. It does, however, make sense in many cases, in order to bring the drive to a defined position.

Adding of relative positioning allows for example endless positioning in one direction for a trimming unit or a conveyor belt (incremental dimension).

5.3.3 Absolute positioning

The target position is approached independent of the current position. In order to execute an absolute positioning we recommend prior homing of the drive. In the case of absolute positioning the target position is a fixed (absolute) position referred to the zero or reference point.

5.3.4 Driving profile generator

Driving profiles are categorized in time-optimal and jerk-limited positioning. In the case of time-optimal positioning the maximum set acceleration is used for starting and braking. The drive approaches the target in the shortest time possible, the velocity profile is trapezoidal, and the acceleration profile is block-shaped. In the case of jerk-limited positioning the acceleration profile is trapezoidal and the

velocity profile is therefore of third order. Since the acceleration changes continuously, the drive is extremely gentle on the mechanics

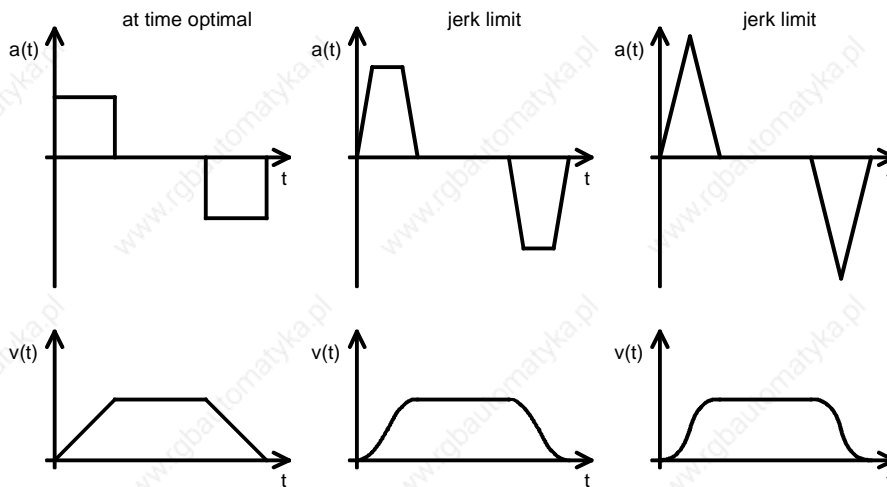

Figure 3: Driving profiles of servo positioning controller ARS-310/xx

5.3.5 Homing

Every positioning control requires a defined zero at startup, which is determined by means of a homing if no multiturn absolute encoder system (HIPERFACE, EnDat) is used. The servo positioning controller ARS-310/xx can do this homing on its own. As reference signals it evaluates different inputs, e.g. the end switch inputs.

A homing can be started by means of a command via the communication interface or automatically with the controller enabling. Optionally a start via the parameterization program WMEMOC can be performed, to carry out a specific homing independent of the controller enabling. The controller enabling acknowledges e.g. error messages and can be switched off depending on the application, without requiring another homing with a new enabling.

Several methods as per the CANopen manual and following DSP 402 are implemented for the homing. Most methods first search for a switch at search velocity. The further movement depends on the method of communication.

If a homing is activated via the fieldbus, there is generally no following positioning to zero. This is done optionally during the start via the controller enabling or RS232. The default setting is „no following positioning“. Ramps and velocities are changeable for the homing. The homing can also be time-optimal and jerk-limited.

6 Mechanical installation

6.1 Important notes

- ❖ Only use the servo positioning controller ARS-310/xx as a built-in device for switch cabinets
- ❖ Mounting position vertical with supply lines [X9] on bottom
- ❖ Mount to control cabinet plate using the small mounting plate
- ❖ Installation spaces:
Keep a minimum distance of 100 mm above to other components and 150 mm underneath the device to ensure sufficient venting.
- ❖ The servo positioning controller ARS-310/xx may be installed adjacently in one switch cabinet without a gap. Please note that excessive heat may cause premature aging and/or damaging of the device.
- ❖ In case of high thermal loads the following minimum distance (measure A in the following drawing) is recommended.
 - ARS-310/5 (UL) 75 mm
 - ARS-310/10 75 mm



The connections of the following illustrations for the servo positioning controller ARS-310/5 (UL) also apply to the servo positioning controller ARS-310/10!

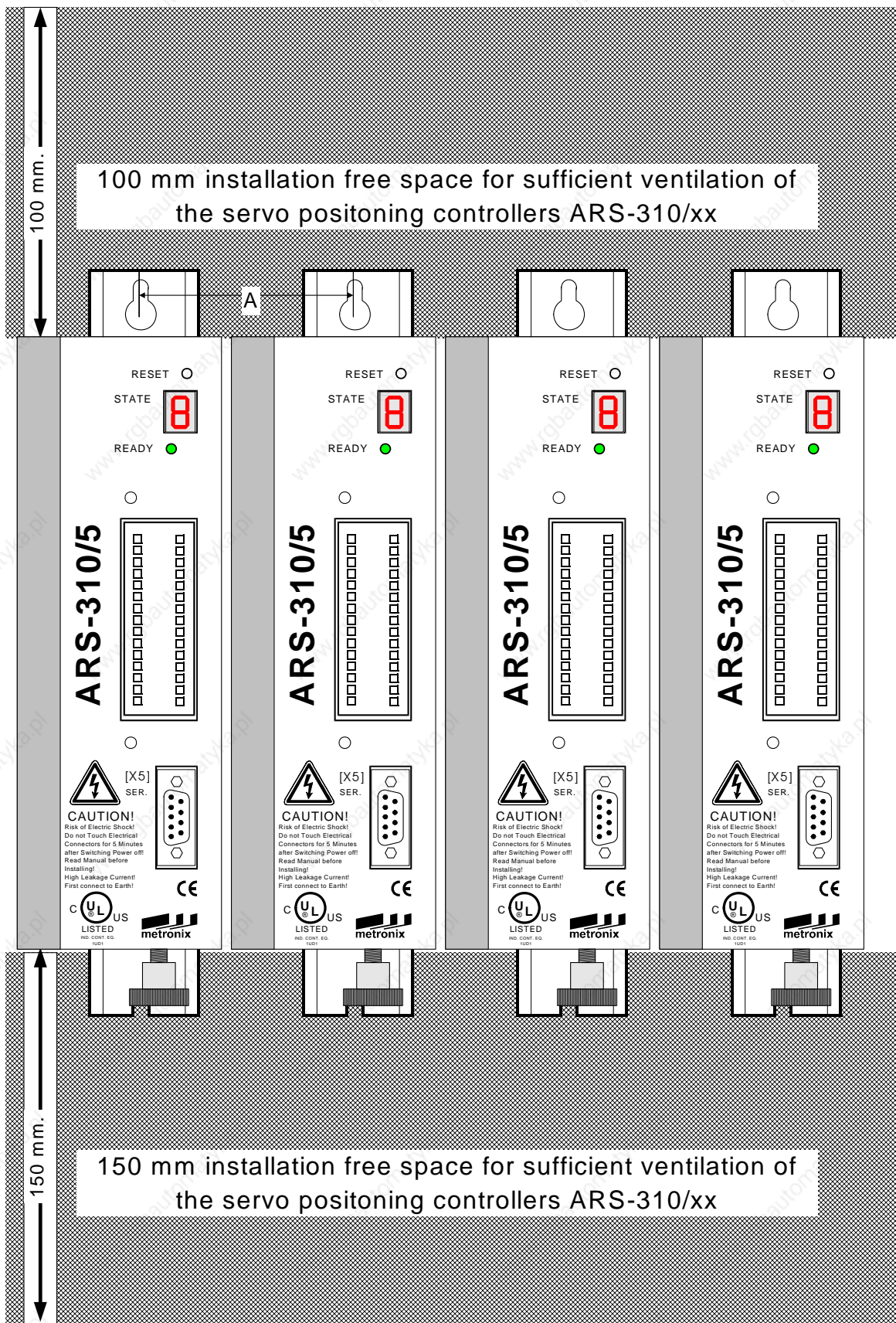

Figure 4: Servo positioning controller ARS-310/xx: Installation space

6.2 View of the device

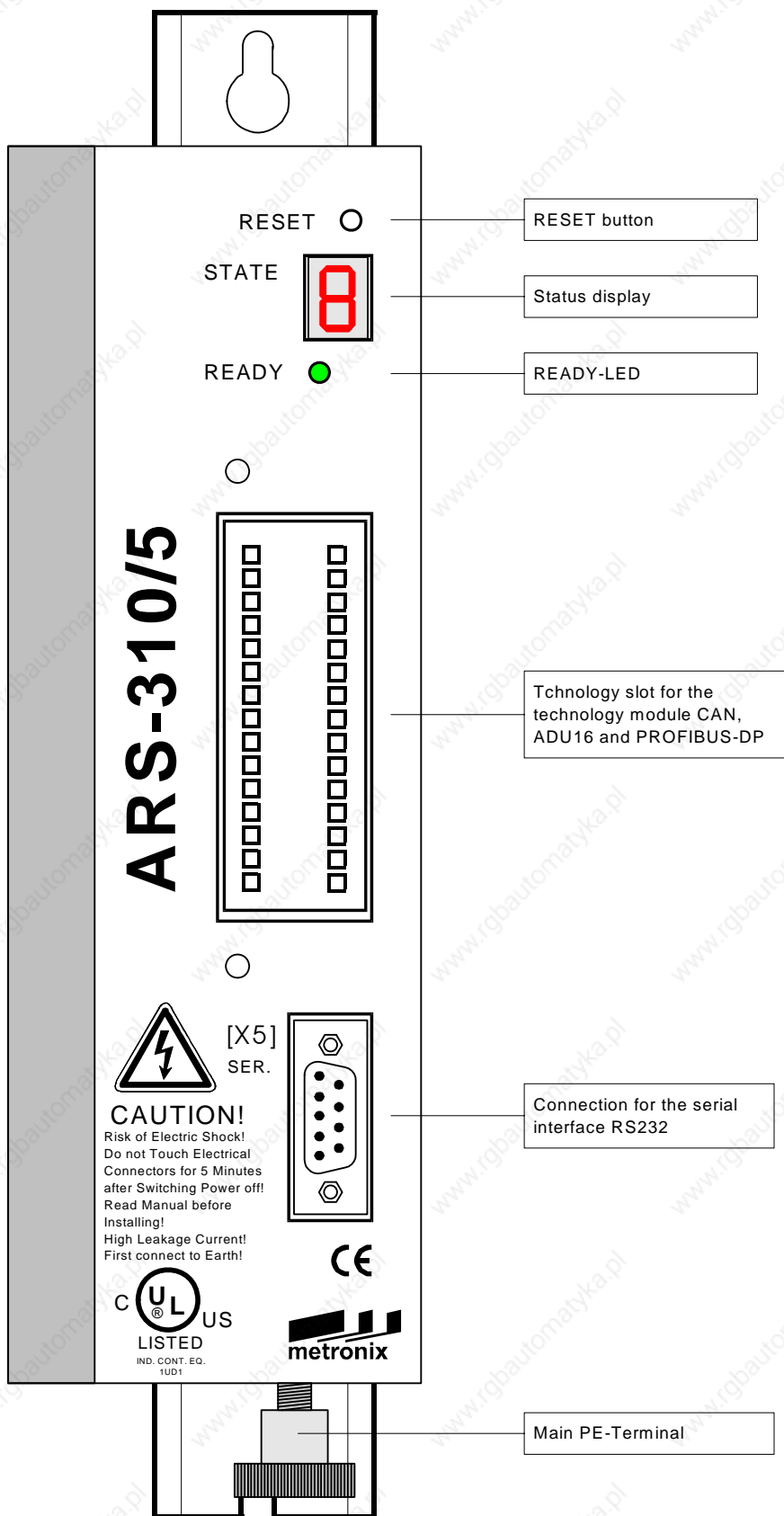

Figure 5: Servo positioning controller ARS-310/5 (UL): Front view

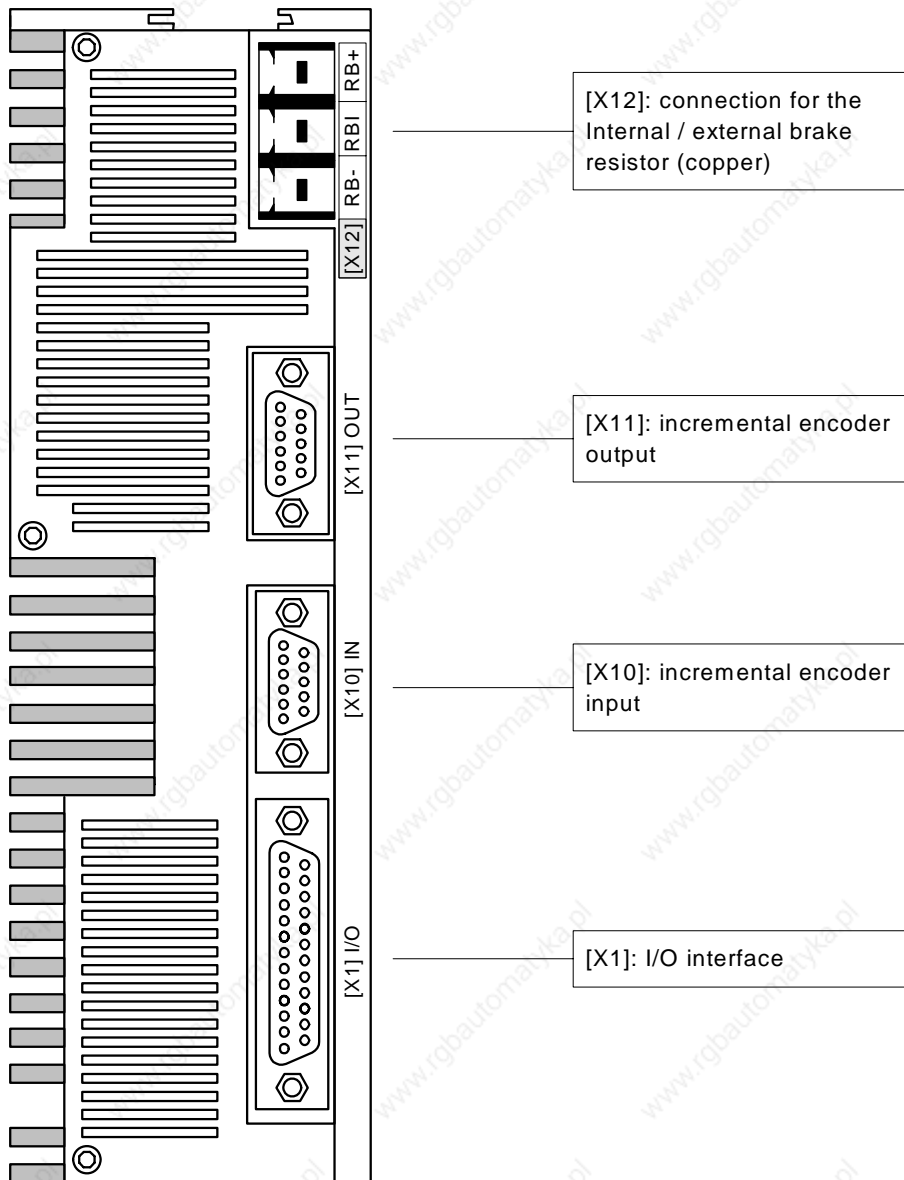

Figure 6: Servo positioning controller ARS-310/5 (UL): Top view

i The connection X12 in the previous illustration for the servo positioning controller ARS-310/5 (UL) is not part of the servo positioning controller ARS-310/10.

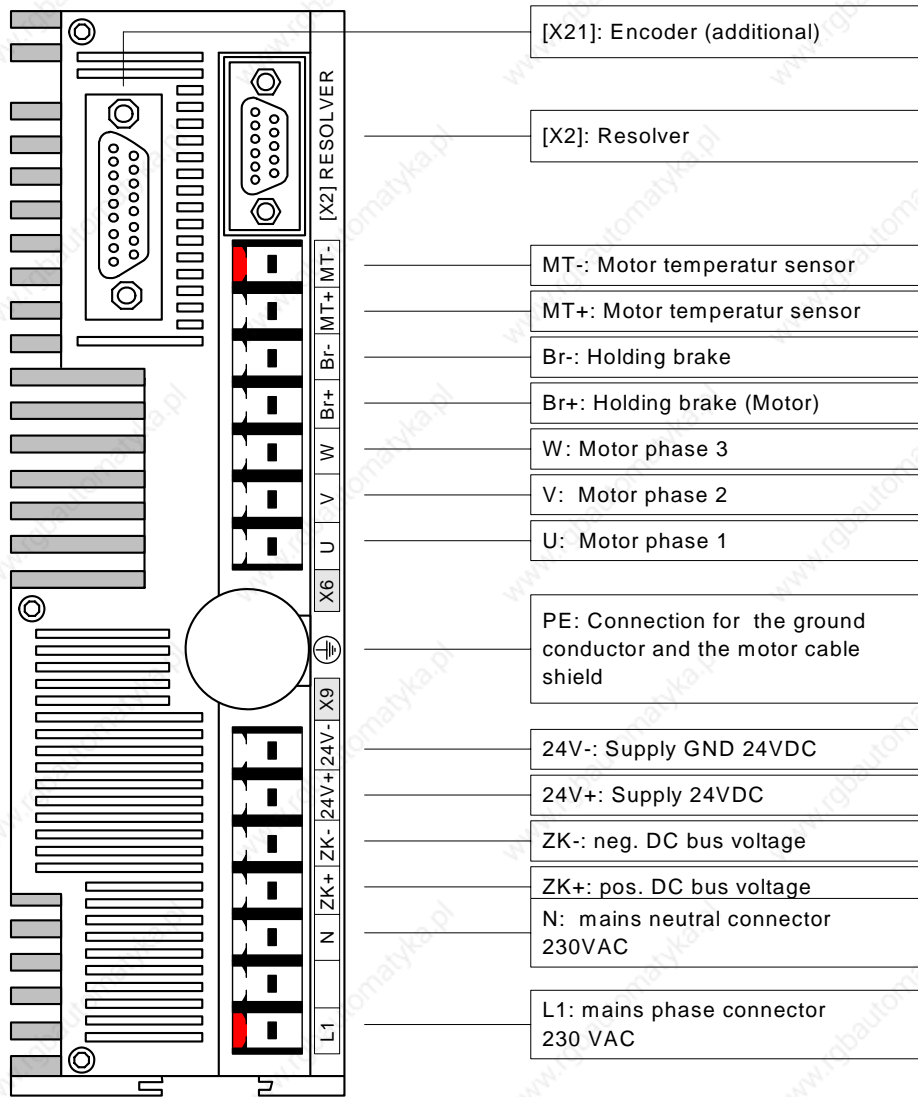

Figure 7: Servo positioning controller ARS-310/5 (UL): Bottom view

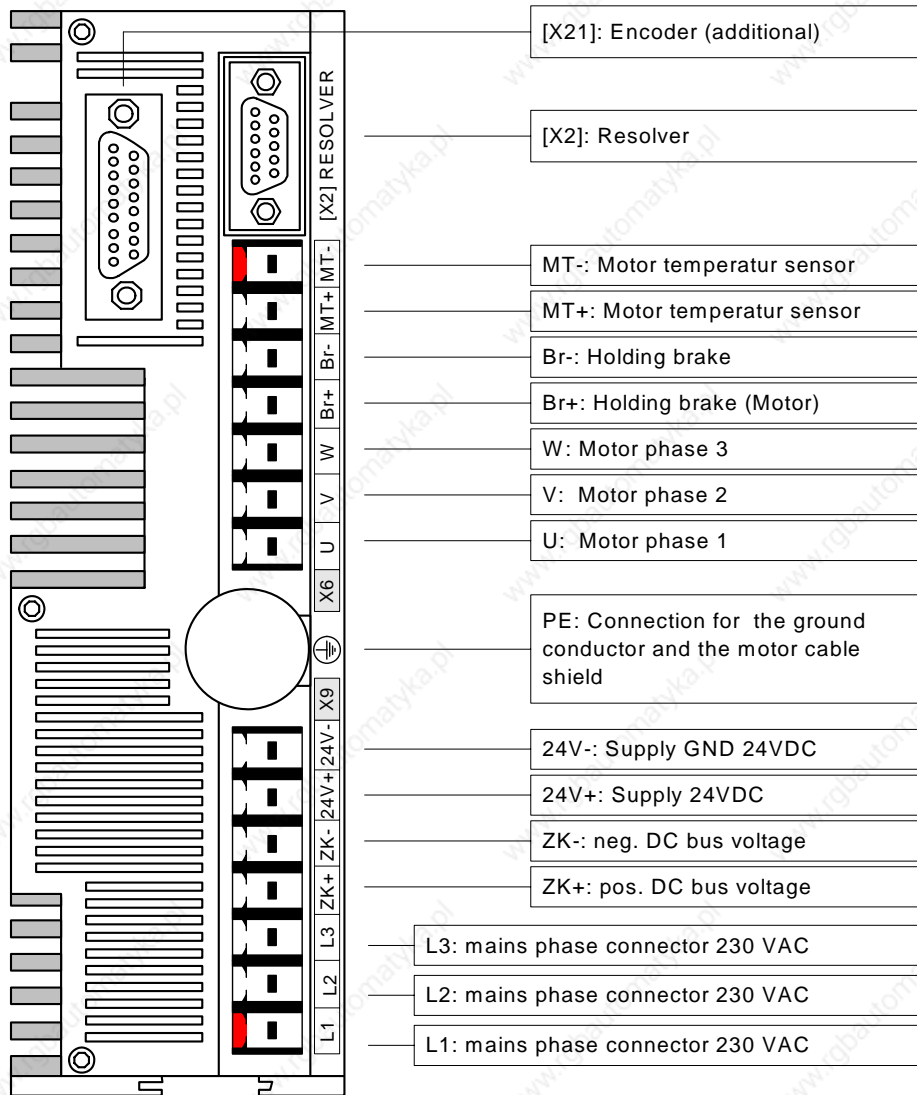

Figure 8: Servo positioning controller ARS-310/10: Bottom view

6.3 Mounting

The servo positioning controller ARS-310/xx has attachment lugs for inserting a mounting plate on the rear side of the device. This plate is used to mount the servo positioning controller vertically to a control cabinet plate.

Please use M5 screws for the mounting of the servo positioning controller ARS-310/xx.

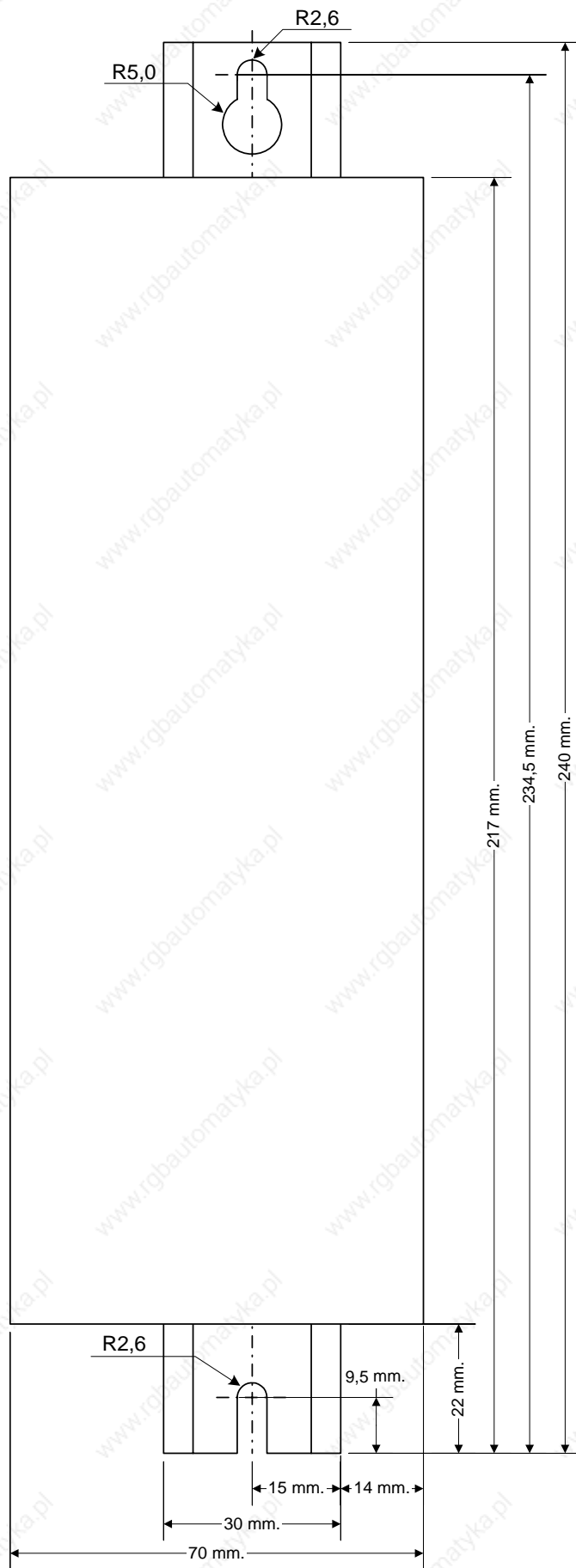

Figure 9: Servo positioning controller ARS-310/xx: Mounting plate

7 Electrical installation

7.1 Connector configuration

The servo positioning controller ARS-310/xx is connected to the supply voltage, the motor, the brake resistor and the holding brakes as shown in Figure 10.

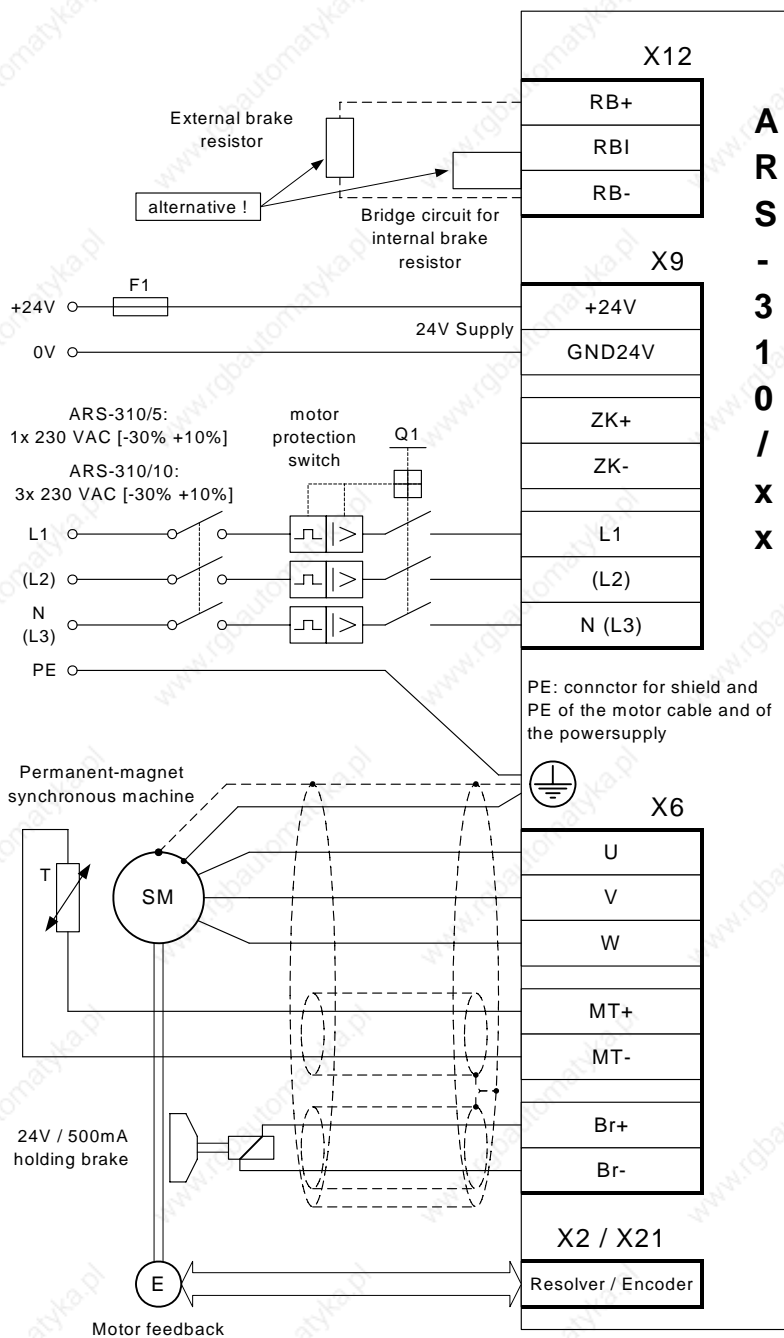

Figure 10: Connection to power supply and motor

The operation of the servo positioning controller ARS-310/xx requires a 24V voltage supply source for the electronics supply, which is connected to the terminals +24V and GND24V.

The connection to the supply for the power output stage is either made to terminals L1 and N (or L1, L2, L3 for ARS-310/10) for AC supply or to ZK+ and ZK- for DC supply.

The motor is connected to terminals U,V,W. The motor temperature switch (PTC or normally closed contact) is connected to terminals MT+ and MT-. If it is lead into one cable together with the motor phases, an additional shielding is necessary for save operation. If an temperature sensor is used which is lead into the encoder cable, it is connected to [X2] or [X21]. The connection of the holding brake is fed to X6 and need as the temperature wiring an additional shielding.

The connection of the shaft encoder via the D-Sub connector to [X2] is roughly shown in Figure 10.

The servo positioning controller ARS-310/xx must be connected to ground with its PE connection.

The ARS-310/xx must be completely wired first. Only then may the operating voltages for the DC bus and the electronics be switched on. In the case of inverted wiring of the operating voltage connections, excessive operating voltage or in the case of confusing the connections for operating voltage and motor the servo positioning controller will be damaged.

7.2 ARS-310/xx complete system

The complete servo positioning controller ARS-310/xx system is shown in Figure 11. The following components are required for using the servo positioning controller:

- ❖ Main switch mains supply
- ❖ Fault current protection switch (RCD), AC/DC sensitive 300mA
- ❖ Automatic circuit breaker
- ❖ Servo positioning controller ARS-310/xx
- ❖ Motor with motor cable
- ❖ Mains cable
- ❖ if required, an external brake resistor for the ARS-310/5 (UL)

The parameterization requires a PC with serial connection cable.

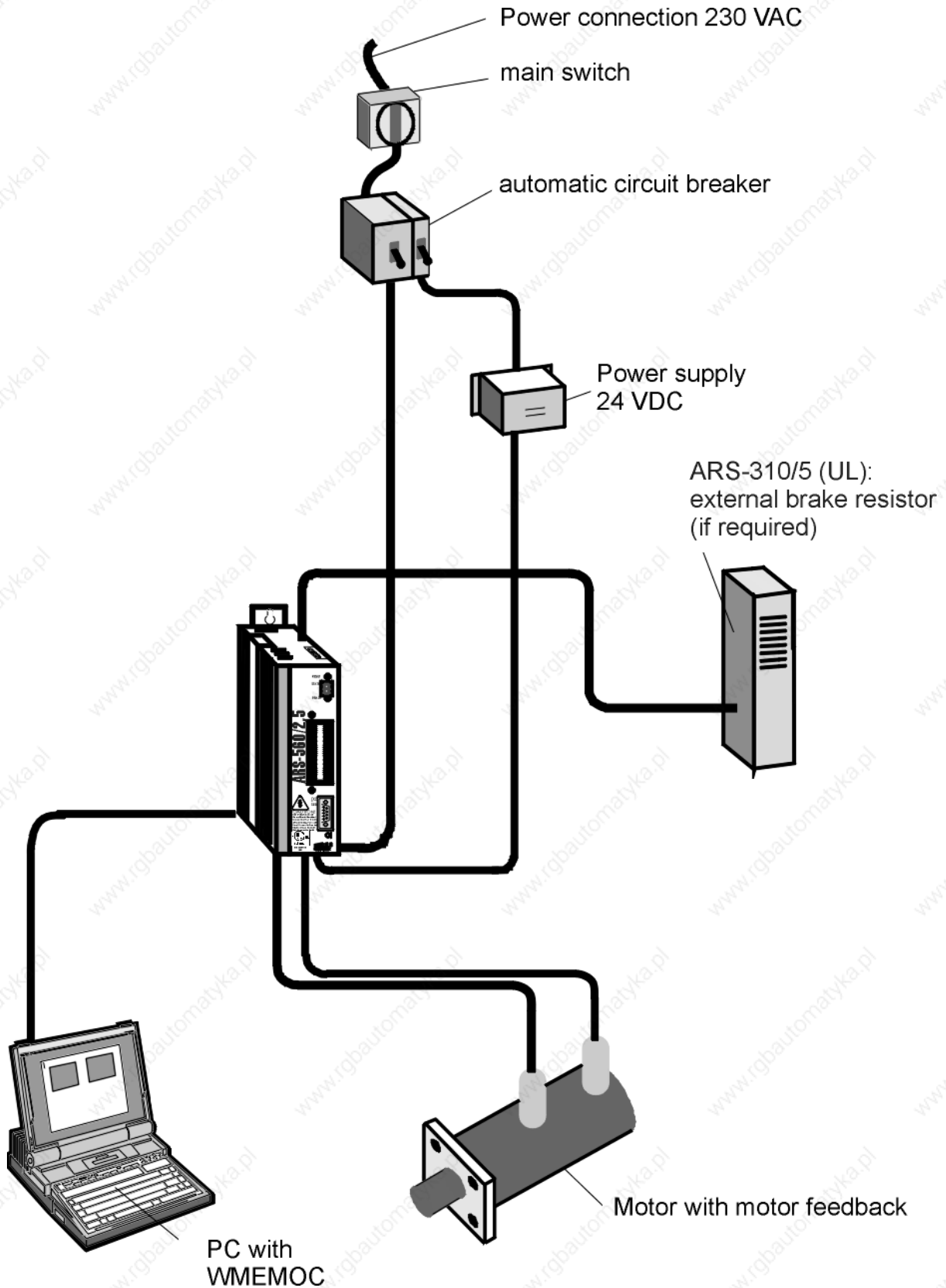

Figure 11: Complete setup of the ARS-310/xx with motor and PC

7.3 Connection: Power supply [X9]

The servo positioning controller ARS-310/xx receives its 24 VDC power supply for the control electronics also via connector [X9].

Depending on the device the mains voltage supply may be single-phase or three-phase. The ARS-310/10 needs a 3-phase supply. As an alternative to AC feed, a direct DC supply for the DC bus is possible by feeding 320VDC to its terminals ZK+ and ZK-.

7.3.1 Device side [X9]

- ❖ PHOENIX Power-Combicon 7-pole PC 4/7-G-7.62

7.3.2 Counterplug [X9]

- ❖ PHOENIX Power-Combicon 7-pole PC 4/7-ST-7.62
- ❖ PHOENIX Coding to PIN7 (GND24V)

7.3.3 Pin configuration [X9]

Table 22: Pin configuration [X9]

Pin No.	Denomination	Value	Specification
1	L1	100..230V AC ±10% 50..60Hz	Mains phase L1 for ARS-310/5 (UL) and ARS-310/10
2	(L2)		(Main phase 2 for ARS-310/10)
3	N (L3)		Mains neutral conductor for ARS-310/5 (UL) (Main phase 3 for ARS-310/10)
4	ZK+	ZK+	Pos. DC bus voltage
5	ZK-	ZK-	Neg. DC bus voltage
6	+24V	+24V / 1A	Supply for control part (0.5A) and holding brake (0.5A)
7	GND24V	GND24	Reference potential supply

7.3.4 Cable type and design [X9]

The mentioned cable denominations refer to cables by Lapp. They have proven effective and are successfully used in many applications. However, similar cables from other manufacturers, e.g. Lütze or Helukabel, may also be used.

For the 230V supply:

- ❖ LAPP KABEL ÖLFLEX-CLASSIC 110; 3 x 1.5 mm²

7.3.5 Connection notes [X9]

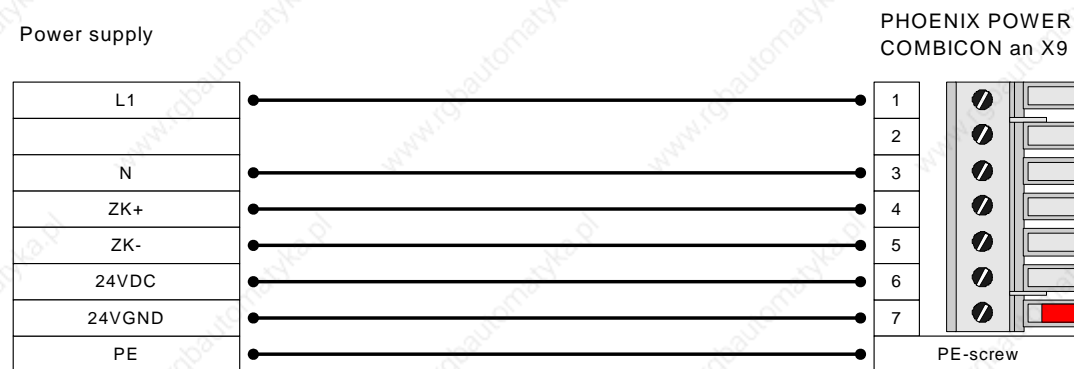

Figure 12: Supply [X9] for the servo positioning controller ARS-310/5 (UL)

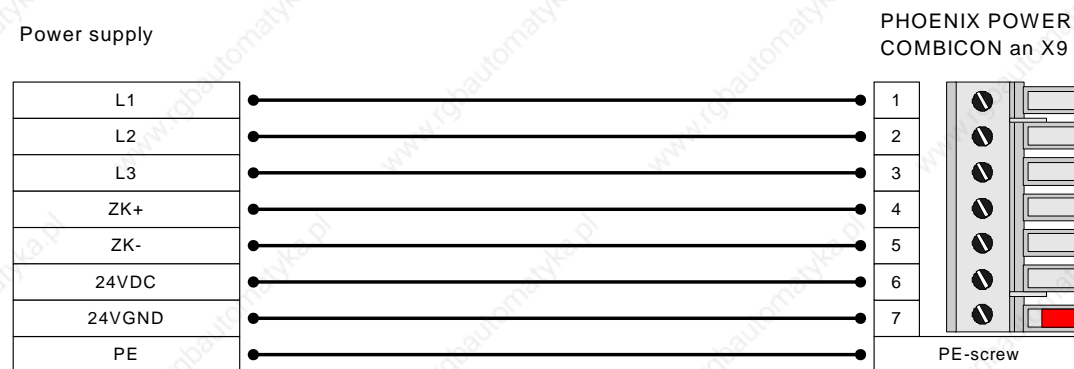

Figure 13: Supply [X9] for the servo positioning controller ARS-310/10

7.4 Connection: external brake resistor [X12]

The servo positioning controller ARS-310/xx has an internal brake chopper with brake resistor. For more brake power it is possible to connect an external brake resistor to the connector [X12] in case of an ARS-310/5 (UL) is given.

Table 23: ARS-310/5 (UL) Connector [X12]: External brake resistor

Pin No.	Denomination	Value	Specification
1	RB+	< 400V DC	External brake resistor positive terminal
2	RBI	< 400V DC	Brake chopper connection for internal brake resistor against RB-
3	RB-	< 400V DC	Brake chopper connection for external brake resistor against RB+



If no external brake resistor is used, a bridge must be connected between PIN2 and PIN3, in order to activate the internal brake resistor!

7.5 Connection: Motor [X6]

7.5.1 Device side [X6]

- ❖ PHOENIX Power-Combicon 7.pole PC 4/7-G-7.62

7.5.2 Counterplug [X6]

- ❖ PHOENIX Power-Combicon 7.pole PC 4/7-ST-7.62
- ❖ PHOENIX Coding to PIN1 (U)

7.5.3 Pin configuration [X6]

Table 24: Pin configuration [X6]

Pin No.	Denomination	Value	Specification
1	U	0...280 V _{rms}	Connection of three motor phases
2	V	0..5 A _{rms} (ARS-310/5 (UL))	
3	W	0..10 A _{rms} (ARS-310/10) 0...1000Hz	
4	Br+	24 V brake, >500mA	Holding brake (motor), signal level dependent on switch status, high side / low side switch
5	Br-	0 V brake	
6	MT+	+5V / 5mA	Motor temperature sensor, normally closed contact, PTC
7	MT-	GND	



The cable shield on the PE wire of the motor cable must be connected to the PE screw terminal.



The wiring for the temperature sensor is must fulfil the regards of EN50178 as far as save potential isolation between all control (24V) potentials and main power is concerned.

7.5.4 Cable type and design [X6]

The mentioned cable denominations refer to cables by Lapp. They have proven effective and are successfully used in many applications. However, similar cables from other manufacturers, e.g. Lütze or Helukabel, may also be used.

- ❖ LAPP KABEL ÖLFLEX-SERVO 700 CY; 4 G 1.5 + 2 x (2 x 0.75) StD-CY; Ø 12.7 mm, with tinned total Cu shielding

For highly flexible applications:

- ❖ LAPP KABEL ÖLFLEX-SERVO-FD 755 CP; 4 G 1.5 + 2 x (2 x 0.75 StD) CP; Ø 15.4 mm, with tinned total Cu shielding
for highly flexible use in drag chains

7.5.5 Connection notes [X6]

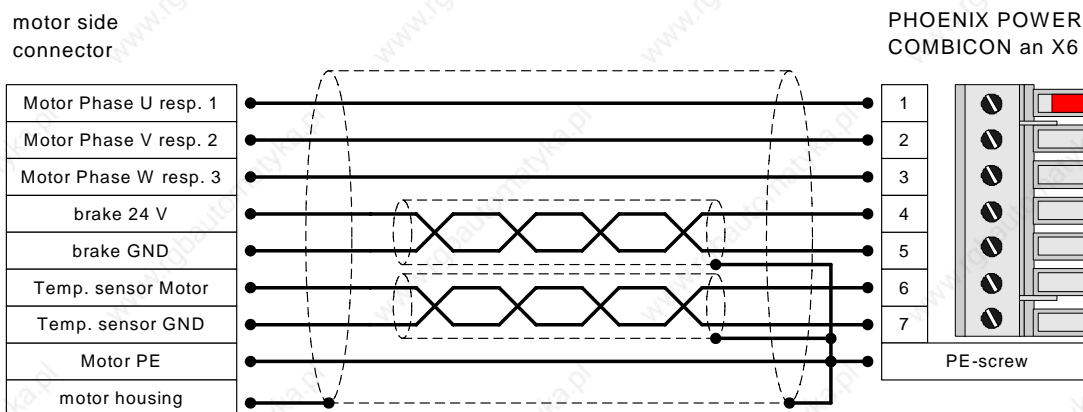

Figure 14: Motor connection [X6]

- ❖ Connect the inner shields to the PE-screw; maximum length 40 mm.
- ❖ Length of unshielded cores maximum 35 mm.
- ❖ Connect total shield on controller side flat to PE-screw; maximum length 40 mm.
- ❖ Connect total shield on motor side flat to connector or motor housing; maximum length 40 mm.

Via terminals ZK+ and ZK- the DC bus of several servo positioning controllers ARS-310/xx can be interconnected. The coupling of the DC bus is interesting for applications with high brake energies or if movements have to be carried out even in the case of power failure.

A holding brake can be connected to terminals BR+ and BR- of the motor. The arresting brake is fed by the servo positioning controller's power supply. Note the maximum output current provided by the servo positioning controller ARS-310/xx. A relay may have to be placed between the device and the arresting brake as shown in Figure 15:

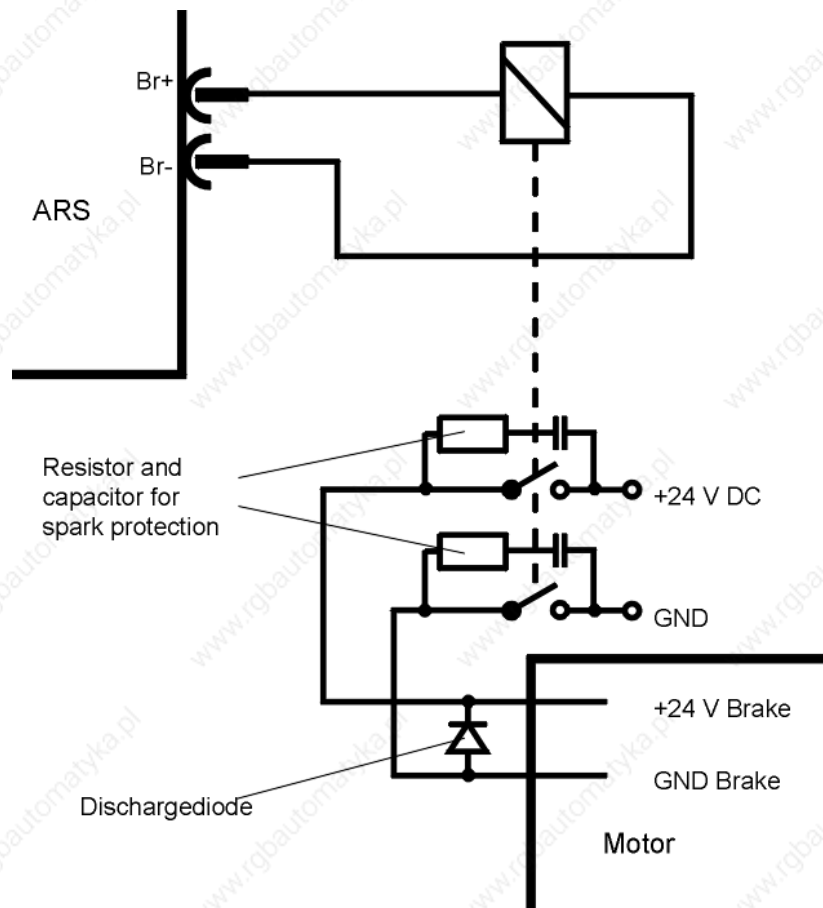

Figure 15: Connecting a holding brake with high current draw (> 0.5A) to the device



The switching of inductive direct current via relay produces strong currents and sparking. For interference suppression we recommend integrated RC suppressor elements, e.g. by Evox RIFA, denomination: PMR205AC6470M022 (RC element with 22Ω in series with 0.47μF).

7.6 Connection: I/O communication [X1]

The following Figure 16 shows the principle function of the digital and analog inputs and outputs. The servo positioning controller ARS-310/xx is shown on the right hand side, the controller connection on the left. The cable design is also visible.

The servo positioning controller ARS-310/xx features two potential ranges:

Analog inputs and outputs:

All analog inputs and outputs refer to AGND. AGND is internally connected with GND, the reference potential for the control part with μC and AD converters in the controller. This potential range is galvanically separated from the 24V range and from the DC bus.

24V inputs and outputs:

These signals refer to the 24V supply voltage of the servo positioning controller ARS-310/xx which is fed via [X9], and separated from the reference potential of the control part by means of optocouplers.

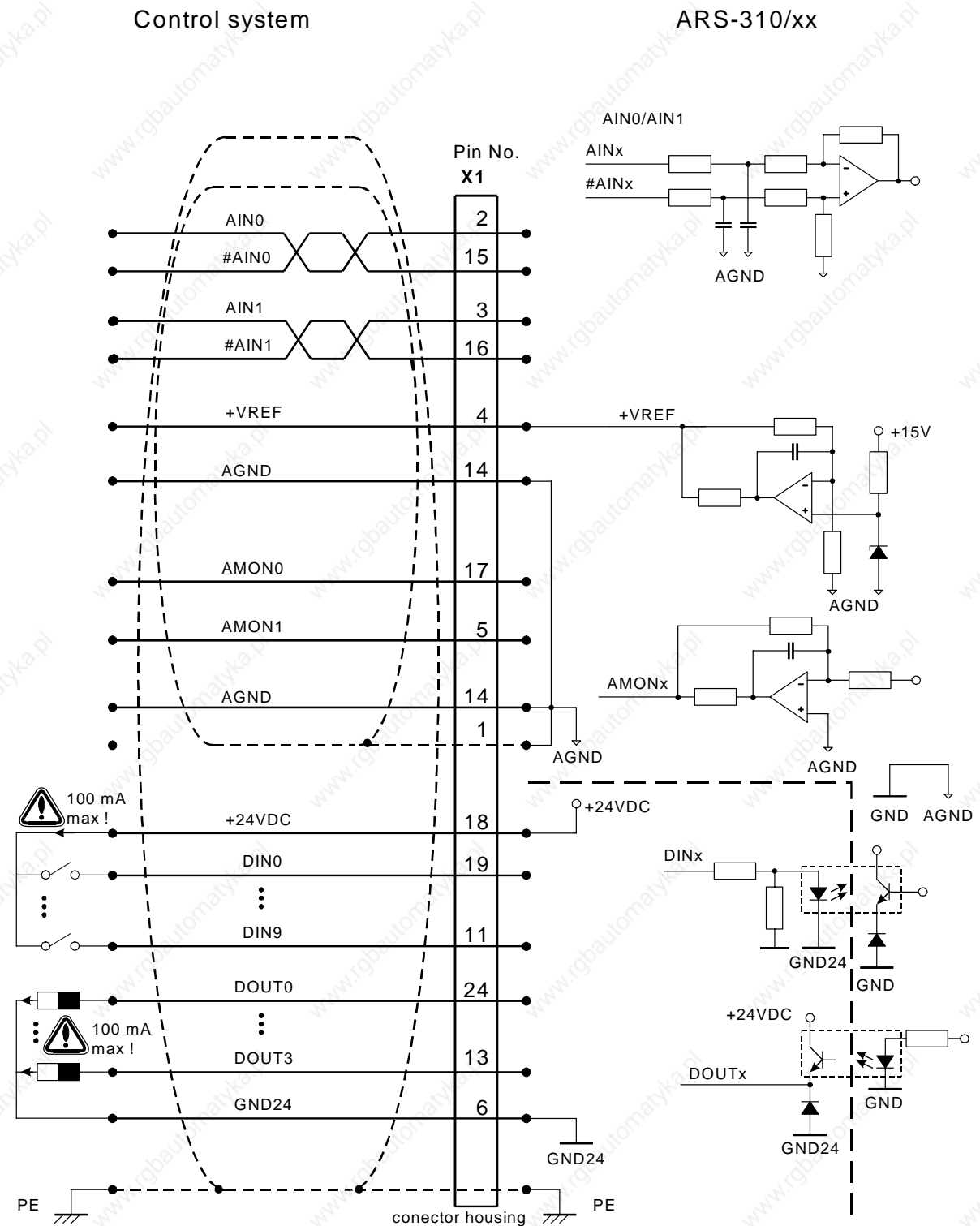

Figure 16: Basic circuit diagram connector [X1]

The servo positioning controller ARS-310/xx comprises two differential (AIN0/AIN1) analog inputs, designed for input voltages within a range of $\pm 10V$. The inputs AINx and #AINx are lead to the control via twisted cables (twisted pair design).

If the control comprises single-ended outputs, the output is connected to AINx and #AINx is put on the reference potential of the control. If the control has differential outputs, they are to be connected 1:1 to the differential inputs of the servo positioning controller ARS-310/xx.

The reference potential AGND is connected to the reference potential of the control. This is necessary in order to prevent the differential input of the servo positioning controller ARS-310/xx from being overridden by high "common-mode interference".

There are two analog monitor outputs with output voltages in the range of $\pm 10V$ and an output for a reference voltage of $+10V$. These outputs can be led to the superimposed control, the reference potential AGND must be carried along. If the control has differential inputs, the "+"-input of the control is connected to the output of the servo positioning controller ARS-310/xx and "-"-input of the control with AGND.

7.6.1 Device side [X1]

- ❖ D-SUB connector, 25-pole, female

7.6.2 Counterplug [X1]

- ❖ D-SUB connector, 25-pole, male
- ❖ Housing for 25-pole D-SUB connector with bolting screws 4/40 UNC

7.6.3 Pin configuration [X1]

Table 25: Connector configuration: I/O communication [X1]

Pin No.	Denomination	Value	Specification
1	AGND	0V	Shield for analog signals, AGND
14	AGND	0V	Reference potential for analog signals
2	AIn0	$U_{in} = \pm 10V$ $R_I = 20k\Omega$	Setpoint input 0, differential, max. 25V input voltage
15	#AIn0		
3	Ain1	$U_{in} = \pm 10V$ $R_I = 20k\Omega$	Setpoint inputs 1, differential, max. 25V input voltage
16	#Ain1		
4	+VREF	+10V	Reference output for e.g. setpoint potentiometer
17	AMON0	$\pm 10V$	Analog monitor output 0
5	AMON1	$\pm 10V$	Analog monitor output 1
18	+24V	24V / 100mA	24V output voltage (24V connected to X9 is outputted here)
6	GND24	corresponding GND	Reference potential for digital I/Os
19	DIn0	POS bit0	Target selection positioning bit0
7	DIn1	POS bit1	Target selection positioning bit1
20	DIn2	POS bit2	Target selection positioning bit2
8	DIn3	POS bit3	Target selection positioning bit3
21	DIn4	FG_E	Power stage enable
9	DIn5	FG_R	Controller enable
22	DIn6	END0	Input limit switch 0
10	DIn7	END1	Input limit switch 1
23	DIn8	START	Input for positioning start
11	DIn9	SAMP	High-speed input
24	DOut0 / READY	24V / 100mA	Output operational
12	DOut1	24V / 100mA	Output freely programmable
25	DOut2	24V / 100mA	Output freely programmable
13	DOut3	24V / 100mA	Output freely programmable

7.6.4 Cable type and design [X1]

The mentioned cable denominations refer to cables by Lapp. They have proven effective and are successfully used in many applications. However, similar cables from other manufacturers, e.g. Lütze or Helukabel, may also be used.

- ❖ LAPP KABEL UNITRONIC-LiYCY; 25 x 0,25 mm²

Figure 16 shows the cable between the servo positioning controller ARS-310/xx and the control. The cable shown has two cable shields.

The outer cable shield is connected on both sides to PE. Inside the servo positioning controller the connector housing of the D-Sub connector is connected to PE. When using metal D-Sub connector housings the cable shield is simply squeezed underneath the strain relief.

Often, an unshielded cable is sufficient for the 24V signals. In heavily disturbed surroundings or in the case of long cables ($l > 2\text{m}$) between the control and the servo positioning controller ARS-310/xx Metronix recommends the use of shielded cables.

In spite of the differential design of the analog inputs of the ARS-310/xx the cables should not be unshielded, since interference, e.g. due to switching contacts or final stage interference's of the converters can reach high amplitudes. They couple into the analog signals and cause common-mode interference, which may lead to deviation of the analog measured values.

In the case of limited cable lengths ($l < 2\text{m}$, wiring inside control cabinet) the outer dual-sided PE shield is enough to guarantee undisturbed operation.

For optimal interference suppression on the analog signals the cores for the analog signals are to be shielded together and separate from others. This internal cable shield is at the ARS-310/xx on one side connected to AGND (Pin 1 or 14). It can be connected on both sides in order to establish a connection between the reference potentials of the control and the servo positioning controller ARS-310/xx. Pins 1 and 14 are directly connected to each other inside the controller.

7.6.5 Connection notes [X1]

The digital inputs are designed for control voltages of 24V. Due to the high signal level a higher interference immunity of these inputs is already guaranteed. The servo positioning controller ARS-310/xx provides a 24V auxiliary voltage, which may be loaded with a maximum of 100 mA. This way the inputs can be activated directly via switches. Activation via the 24V outputs of a PLC is, of course, also possible.

The digital outputs are designed as so-called "high-side switches". That means that the 24V of the servo positioning controller ARS-310/xx are actively switched through to the output. Loads such as lamps, relays, etc. are thus switched from the output to GND24. The four outputs DOUT0 to DOUT3 can be loaded with a maximum of 100mA each. The outputs can also be lead directly to 24V inputs of a PLC.

7.7 Connection: Resolver [X2]

7.7.1 Device side [X2]

- ❖ 1 D-SUB connector, 9-pole, female

7.7.2 Counterplug [X2]

- ❖ D-SUB connector, 9-pole, male
- ❖ Housing for 9-pole D-SUB connector with bolting screws 4/40 UNC

7.7.3 Pin configuration [X2]

Table 26: Pin configuration [X2]

Pin No.	Denomination	Value	Specification
1	S2	$3,5V_{RMS} / 10kHz$	SINE trace signal, differential
6	S4	$R_i > 5k\Omega$	
2	S1	$3,5V_{RMS} / 10kHz$	COSINE trace signal, differential
7	S3	$R_i > 5k\Omega$	
3	AGND	0V	Shield for signal pairs (inner shield)
8	MT-	GND	Reference potential temperature sensor
4	R1	$7V_{RMS} / I_A \leq 50mA_{RMS}$	Carrier signal for resolver
9	R2	GND	
5	MT+	+5V / 5mA	Motor temperature sensor, normally closed contact, PTC, KTY...

7.7.4 Cable type and design [X2]

The mentioned cable denominations refer to cables by Lapp. They have proven effective and are successfully used in many applications. However, similar cables from other manufacturers, e.g. Lütze or Helukabel, may also be used.

- ❖ LAPP KABEL ÖLFLEX-SERVO 720 CY; 3 x (2 x 0,14 CY) + 2 x (0,5 CY) CY; Ø 8.5 mm, with tinned total Cu shielding
Error during angle detection up to ca. 1.5° at 50 m cable length
 - 2 x (0.5 CY) use carriers for the resolver!

For highly flexible applications:

- ❖ LAPP KABEL ÖLFLEX-SERVO-FD 770 CP; 3 x (2 x 0,14 D12Y) + 2 x (0,5 D12Y) CP; Ø 8.3 mm, with tinned total Cu shielding
Error during angle detection up to ca. 1.5° at 50 m cable length
 - 2 x (0.5 D12Y) use carriers for the resolver!

7.7.5 Connection notes [X2]

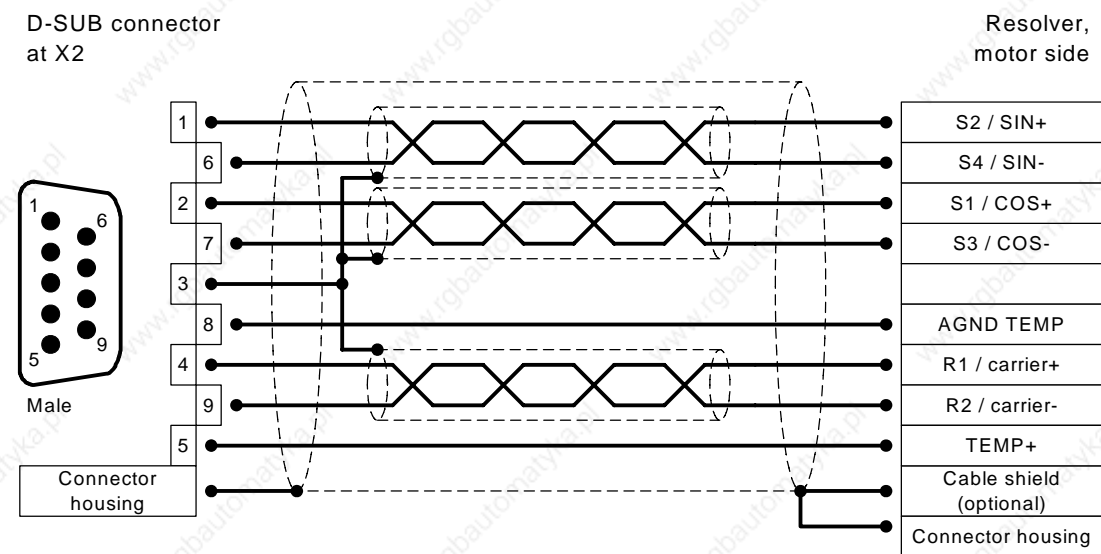

Figure 17: Pin configuration: Resolver connection [X2]

- ❖ The outer shield is always connected to PE (connector housing) on the controller side.
- ❖ The three inner shields are connected on one side of the servo positioning controller ARS-310/xx to PIN3 of [X2].

7.8 Connection: Encoder [X2]

7.8.1 Device side [X2]

- ❖ D-SUB connector, 15-pole, female

7.8.2 Counterplug [X2]

- ❖ D-SUB connector, 15-pole, male
- ❖ Housing for 15-pole D-SUB connector with bolting screws 4/40 UNC

7.8.3 Pin configuration [X2]

Table 27: Pin configuration: Stegmann “HIPERFACE” Encoder evaluation

Pin No.	Denomination	Value	Specification
1	SIN	$1 V_{SS} \pm 10\%$	SINE trace signal (differential) from high-resolution incremental encoder
6	SIN_REF	$R_i \approx 120 \Omega$	
2	COS	$1 V_{SS} \pm 10\%$	COSINE trace signal (differential) from high-resolution incremental encoder
7	COS_REF	$R_i \approx 120 \Omega$	
3	GND	0 V	Reference potential encoder supply and motor temperature sensor
8	+12V	12 V / 130 mA	Output supply
4	DATA+	RS485	Bidirectional RS485 data line (differential), zero puls after initialisation
9	DATA-		
5	TEMP+	+5 V / $R_i = 2 k\Omega$	Motor temperature sensor, normally closed contact, PTC

Table 28: Pin configuration: YASKAWA Incremental encoder [X2]

Pin No.	Denomination	Value	Specification
1	A	5 V / $R_i \approx 120 \Omega$	Trace signal A (differential) from digital incremental encoder as per RS422 specification
6	#A		
2	B	5 V / $R_i \approx 120 \Omega$	Trace signal B (differential) from digital incremental encoder as per RS422 specification
7	#B		
3	GND	0 V	Reference potential encoder supply and motor temperature sensor
8	+5 V	+5 V \pm 5% 120 mA	Output supply
4	N	5 V / $R_i \approx 120 \Omega$	Index pulse N (differential) from digital incremental encoder as per RS422 specification
9	#N		
5	TEMP+	5 V	Motor temperature sensor, normally closed contact, PTC

7.8.4 Cable type and design [X2]

We recommend using the encoder connection cables released for their product by the corresponding manufacturer (Heidenhain, Stegmann, etc.). If the manufacturer does not recommend a particular cable, we recommend the assembly of the encoder connections cables as described below.

7.8.5 Connection notes [X2]

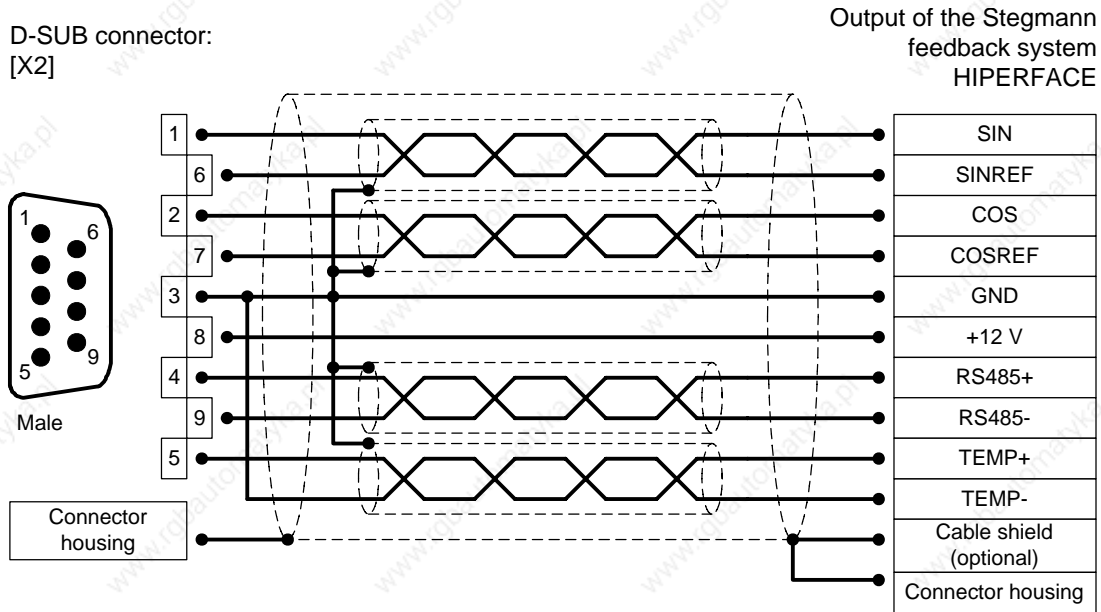

Figure 18: Pin configuration [X2]: In case of the Stegmann (HIPERFACE) encoder evaluation module

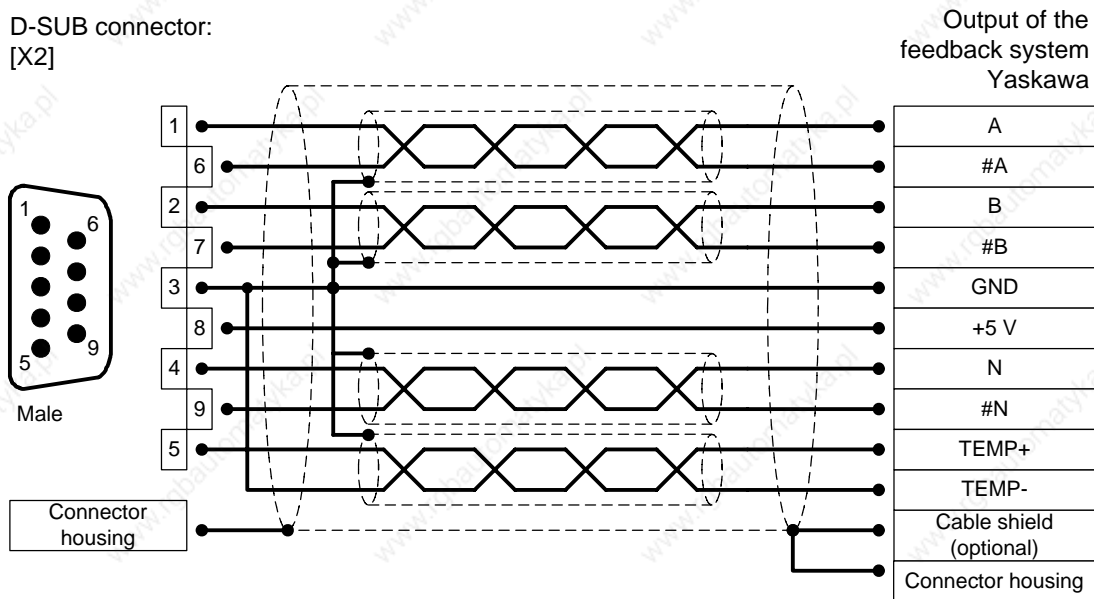

Figure 19: Pin configuration [X2]: In case of the Yaskawa (SGM, Sigma 1) Incremental encoder evaluation module

7.9 Connection: Encoder [X21] (additional 15-pole connector)

7.9.1 Device side [X21] (additional 15-pole connector)

- ❖ D-SUB connector, 15-pole, female

7.9.2 Counterplug [X21] (additional 15-pole connector)

- ❖ D-SUB connector, 15-pole, male
- ❖ Housing for 15-pole D-SUB connector with bolting screws 4/40 UNC

7.9.3 Pin configuration [X21] (additional 15-pole connector)

Table 29: Pin configuration [X21]: analog incremental encoder – additional 15-pole connector

Pin No.	Denomination	Value	Specification
1	MT+	+5 V / $R_i = 2 \text{ k}\Omega$	Motor temperature sensor
9	U SENS+	5 V	Sensor cables for encoder supply
2	U_SENS-	$R_i \approx 1 \text{ k}\Omega$	
10	VCC	5 V $\pm 10\%$ $I_{\max} = 300 \text{ mA}$	Supply voltage for high-resolution incremental encoder
3	GND	0 V	Reference potential encoder supply and motor temperature sensor
11	R	0,2V _{PP} ... 0,8V _{PP}	Reference signal (differential)
4	#R	$R_i \approx 120 \Omega$	
12	COS_Z1	1 V _{PP} $\pm 10\%$	COSINE commutation signal (differential) from high-resolution incremental encoder
5	#COS_Z1	$R_i \approx 120 \Omega$	
13	SIN_Z1	1 V _{PP} $\pm 10\%$	SINE commutation signal (differential) from high-resolution incremental encoder
6	#SIN_Z1	$R_i \approx 120 \Omega$	
14	COS_Z0	1 V _{PP} $\pm 10\%$	COSINE trace signal (differential) from high resolution encoder
7	#COS_Z0	$R_i \approx 120 \Omega$	
15	SIN_Z0	1 V _{PP} $\pm 10\%$	SINE trace signal (differential) from high resolution encoder
8	#SIN_Z0	$R_i \approx 120 \Omega$	

Table 30: Pin configuration [X21]: Incremental encoder with serial data port (EnDat) – additional 15-pole connector

Pin No.	Denomination	Value	Specification
1	TEMP+	+5 V / 5 mA	Motor temperature sensor
2	U_SENS+	5 V	Sensor cables for encoder supply
	U_SENS-	$R_i \approx 1k\Omega$	
10	VCC	5V $\pm 10\%$ $I_{max} = 300$ mA	Supply voltage for high-resolution incremental encoder
3	GND / TEMP-	0 V	Reference potential encoder supply and motor temperature sensor
11	NC		
4	NC		
12	DATA	5 V _{pp}	Bi-directional data line (differential) as per RS485 specification
5	#DATA	$R_i \approx 120 \Omega$	
13	CLK	5 V _{pp}	Clock output (differential) as per RS485 specification
6	#CLK	$R_i \approx 120 \Omega$	
14	COS_Z0	1 V _{pp} $\pm 10\%$	COSINE trace signal (differential) from high-resolution incremental encoder
7	#COS_Z0	$R_i \approx 120 \Omega$	
15	SIN_Z0	1 V _{pp} $\pm 10\%$	SINE trace signal (differential) from high-resolution incremental encoder
8	#SIN_Z0	$R_i \approx 120 \Omega$	

Table 31: Pin configuration [X21]: Digital incremental encoder – additional 15-pole connector

Pin No.		Denomination	Value	Specification
1		A	2 V _{PP} .. 5 V _{PP}	Trace signal A (differential) from digital incremental encoder as per RS422 specification
	9	#A	R _i ≈ 120 Ω	
2		B	2 V _{PP} .. 5 V _{PP}	Trace signal B (differential) from digital incremental encoder as per RS422 specification
	10	#B	R _i ≈ 120 Ω	
3		GND	0 V	Reference potential encoder supply and motor temperature sensor
	11	VCC	5 V ±10% I _{max} = 200 mA	Supply voltage for high-resolution incremental encoder
4		N	2 V _{PP} .. 5 V _{PP}	Index pulse (differential) from digital incremental encoder as per RS422 specification
	12	#N	R _i ≈ 120 Ω	
5		U_SENS-	5 V	Sensor cables for encoder supply
	13	U_SENS+	R _i ≈ 1 kΩ	
6		H_U	0 V / 5 V	Phase U hall sensor for commutation
	14	H_V	R _i ≈ 2 kΩ against VCC	Phase V hall sensor for commutation
7		H_W		Phase W hall sensor for commutation
	15	GND	0 V	Reference potential encoder supply and motor temperature sensor
8		TEMP+	+5 V / 5 mA	Motor temperature sensor +

7.9.4 Cable type and design [X21] additional 15-pole connector

We recommend using the encoder connection cables released for their product by the corresponding manufacturer (Heidenhain, Stegmann, etc.). If the manufacturer does not recommend a particular cable, we recommend the assembly of the encoder connections cables as described below.

D-SUB connector:
[X21]

Output of the
analog incremental encoder

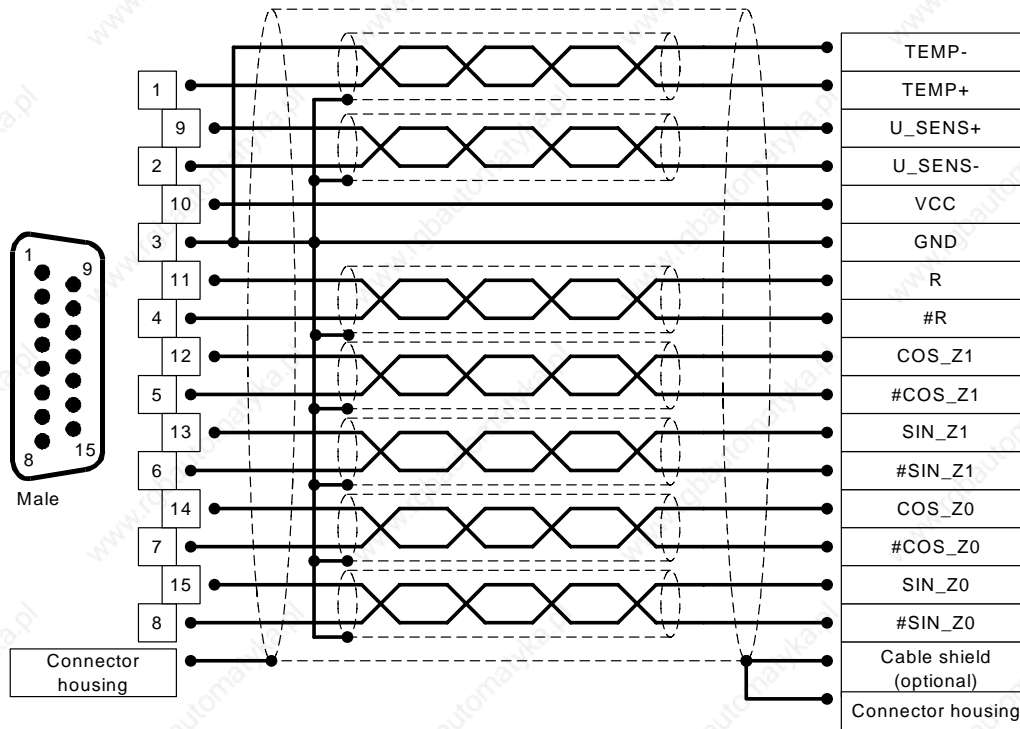

Figure 20: Pin configuration X21: Analog incremental encoder –additional 15-pole connector

D-SUB connector:
[X21]

Output of the
incremental encoder

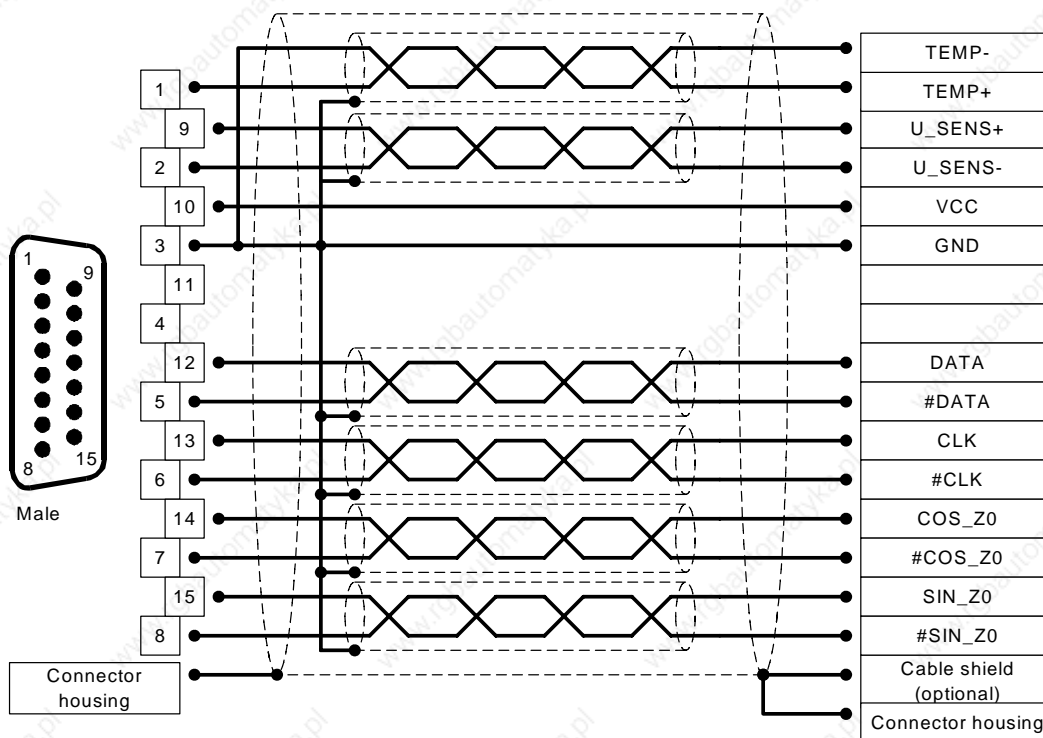

Figure 21: Pin configuration X21: Incremental encoder with serial data port (EnDat) – additional 15-pole connector

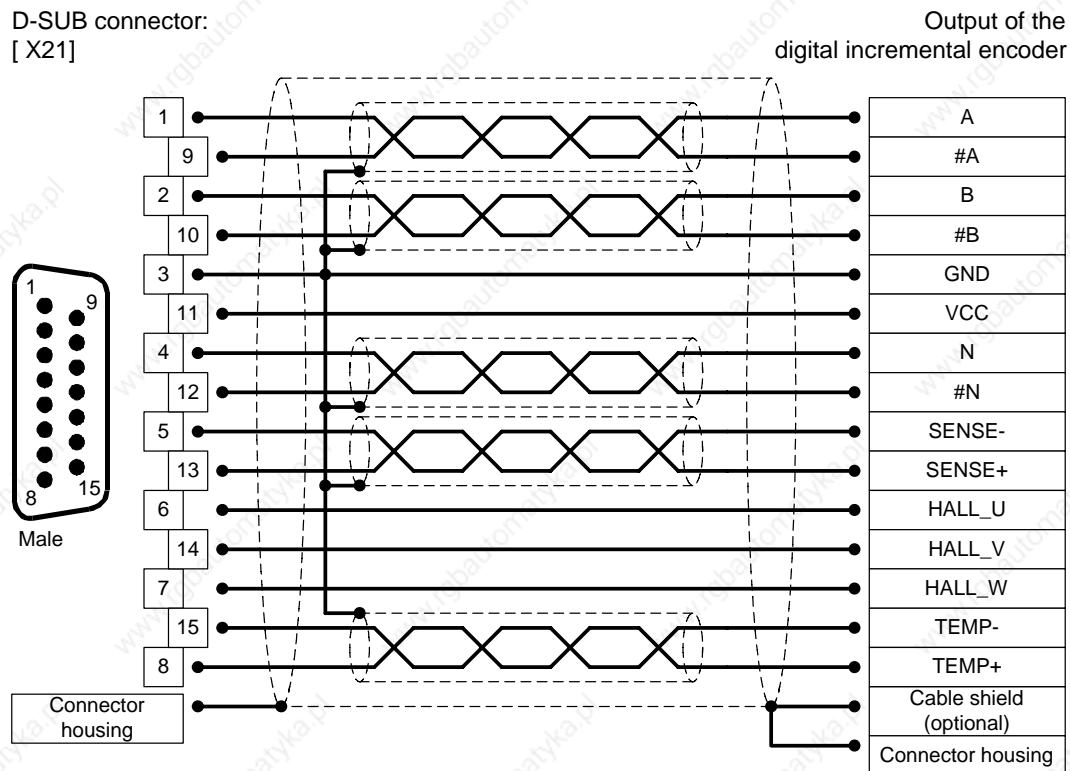

Figure 22: Pin configuration [X21]: Digital incremental encoder –additional 15-pole connector

7.10 Connection: Incremental encoder input [X10]

7.10.1 Device side [X10]

- ❖ D-SUB connector, 9-pole, female

7.10.2 Counterplug [X10]

- ❖ D-SUB connector, 9-pole, male
- ❖ Housing for 9-pole D-SUB connector with bolting screws 4/40 UNC

7.10.3 Pin configuration [X10]

Table 32: Pin configuration [X10]: Incremental encoder input

Pin No.	Denomination	Value	Specification
1	A	$5V / R_1 \approx 120\Omega$	Incremental encoder signal A pos. polarity as per RS422
6	A#	$5V / R_1 \approx 120\Omega$	Incremental encoder signal A neg. polarity as per RS422
2	B	$5V / R_1 \approx 120\Omega$	Incremental encoder signal B pos. polarity as per RS422
7	B#	$5V / R_1 \approx 120\Omega$	Incremental encoder signal B neg. polarity as per RS422
3	N	$5V / R_1 \approx 120\Omega$	Incremental encoder index pulse N pos. polarity as per RS422
8	N#	$5V / R_1 \approx 120\Omega$	Incremental encoder index pulse N neg. polarity as per RS422
4	GND	-	Supply GND for encoder
9	GND	-	Shield for the connection cable
5	VCC	$+5V \pm 5\%$ 100mA	Auxiliary supply, load with 100mA maximum, but short circuit-proof!

7.10.4 Cable type and design [X10]

We recommend encoder connection cables twisted in pairs and the single pairs individually shielded.

7.10.5 Connection notes [X10]

Input [X10] can be used to process incremental encoder signals if they were outputted by simple encoders.

The input amplifier at the signal input is designed for the processing of differential signals as per interface standard RS422. Processing of other signals and levels (e.g. 5V single-ended or 24V_{HTL} from a PLC) may be possible. Please contact your sales representative.

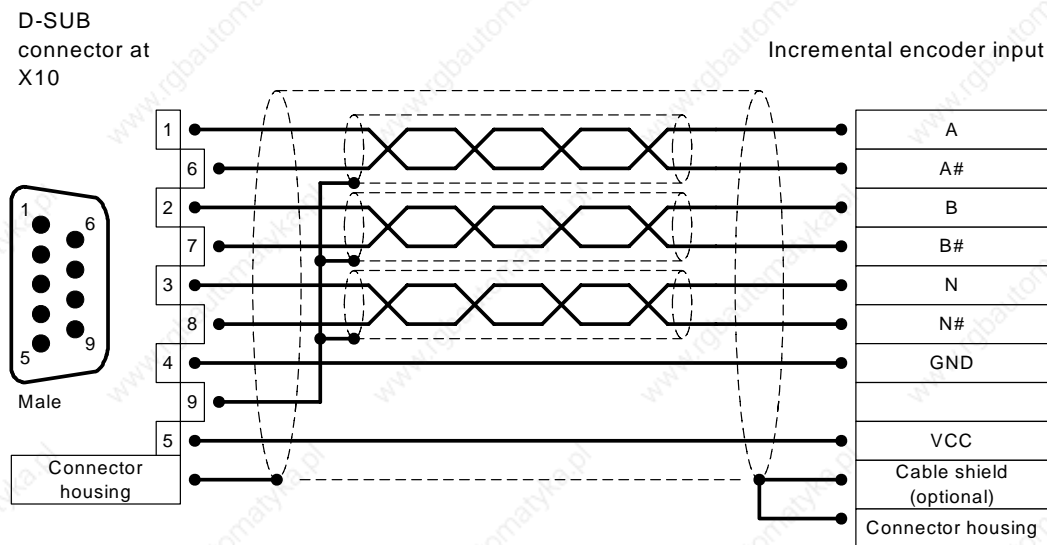

Figure 23: Pin configuration: Input of the incremental encoder [X10]

7.11 Connection: Incremental encoder output [X11]

7.11.1 Device side [X11]

- ❖ D-SUB connector, 9-pole, female

7.11.2 Counterplug [X11]

- ❖ D-SUB connector, 9-pole, male
- ❖ Housing for 9-pole D-SUB connector with bolting screws 4/40 UNC

7.11.3 Pin configuration [X11]

Table 33: Pin configuration [X11]: Incremental encoder output

Pin No.	Denomination	Value	Specification
1	A	5V / $R_A \approx 66\Omega$ *)	Incremental encoder signal A
6	A#	5V / $R_A \approx 66\Omega$ *)	Incremental encoder signal A#
2	B	5V / $R_A \approx 66\Omega$ *)	Incremental encoder signal B
7	B#	5V / $R_A \approx 66\Omega$ *)	Incremental encoder signal B#
3	N	5V / $R_A \approx 66\Omega$ *)	Incremental encoder index pulse N
8	N#	5V / $R_A \approx 66\Omega$ *)	Incremental encoder index pulse N#
4	GND	-	Reference GND for encoder
9	GND	-	Shield for connection cable
5	VCC	+5V \pm 5% 100mA	Auxiliary supply, to be loaded with maximal 100mA, but short-circuit-proof!

*) The value for R_A is the differential output resistance

7.11.4 Cable type and design [X11]

We recommend encoder connection cables twisted in pairs and the single pairs individually shielded.

7.11.5 Connection notes [X11]

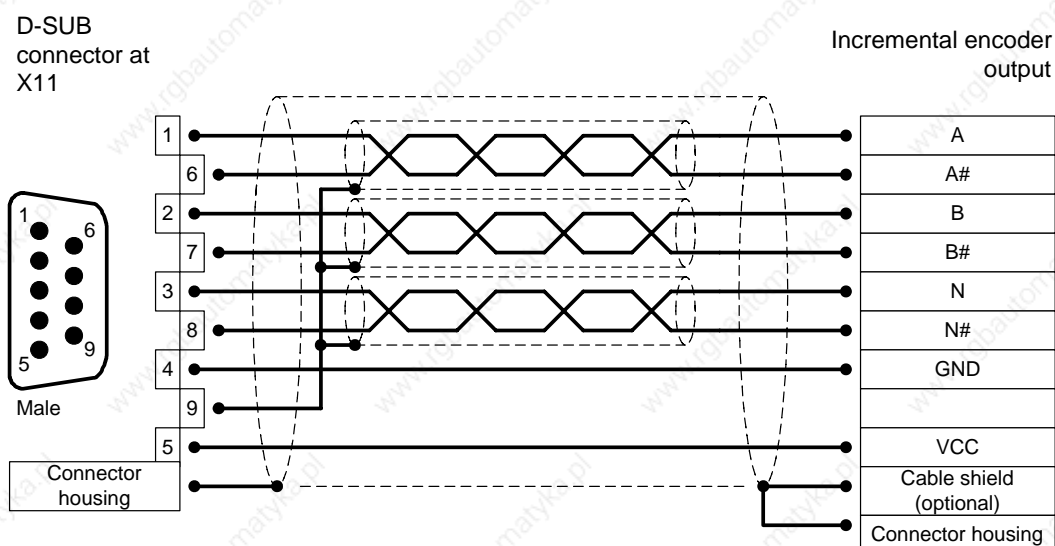

Figure 24: Pin configuration: Incremental encoder output [X11]

The output driver at the signal output provides differential signals (5V) as per interface standard RS422.

Up to 32 other controllers may be driven by one device.



The supply output ([X11] pin no. 5) should not be connected to slave servos

7.12 Connection: CAN-Bus Technology Modul

7.12.1 Device side as presented by the CAN-Bus Module

- ❖ PHOENIX Mini-Combicon female MCD 1,5/14-G1F-3,81

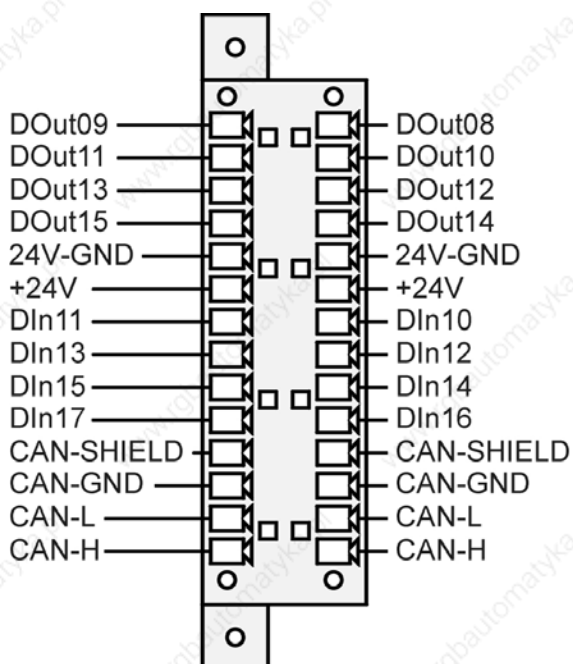

Figure 25: Pin configuration: CAN-Bus module

7.12.2 Counterplug

- ❖ PHOENIX 1x14pol Plug MCVR 1.5/14-STF-3.81
- ❖ PHOENIX 1x14pol Plug MCVW 1.5/14-STF-3.81

7.12.3 Cable type and design

The mentioned cable denominations refer to cables by Lapp. They have proven effective and are successfully used in many applications. However, similar cables from other manufacturers, e.g. Lütze or Helukabel, may also be used.



Technical specifications CAN bus cable: 2 pairs of 2 twisted cores, $d \geq 0.22 \text{ mm}^2$, shielded, loop resistance $< 0.2 \Omega/\text{m}$, characteristic impedance $100\text{-}120 \Omega$

- ❖ LAPP KABEL UNITRONIC BUS CAN; $2 \times 2 \times 0.22$; $\varnothing 7.6 \text{ mm}$, with total Cu shielding

For highly flexible applications:

- ❖ LAPP KABEL UNITRONIC BUS-FD P CAN UL/CSA; $2 \times 2 \times 0.25$; $\varnothing 8.4 \text{ mm}$, with total Cu shielding

7.12.4 Connection notes



When cabling the connector via the CAN bus, make sure to observe the following information and notes, to ensure a stable and interference-free system. Improper cabling may cause the CAN bus to malfunction which in turn can cause the controller to shut down with an error for safety reasons.

The CAN bus provides a simple and fail-safe way of connecting all components of a system, assuming, however, compliance with the following notes on cabling.

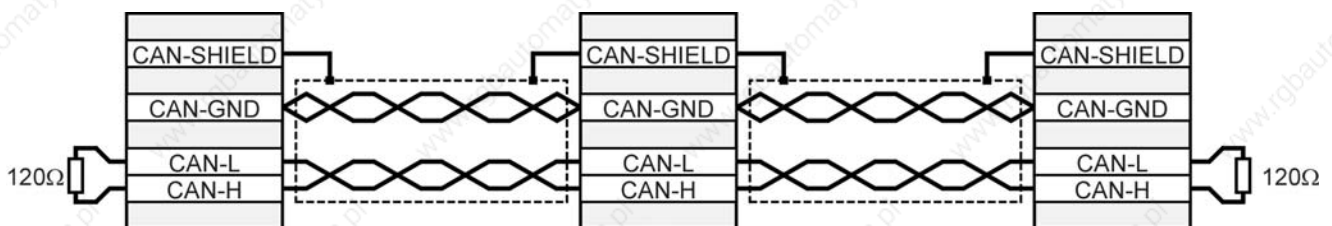

Figure 26: Cabling example for CAN-Bus

- ❖ The individual nodes of a network are always connected in line, so that the CAN cable is looped through from controller to controller (see Figure 26).
- ❖ On both ends of the CAN bus cable must be exactly one terminating resistor of $120\Omega \pm 5\%$. Such resistors are often already installed on CAN boards or in PLCs, which must be taken into consideration.

- ❖ **Shielded** cables with exactly two **twisted** pairs must be used for cabling.
- ❖ Use a twisted pair for the connection of CAN-H and CAN-L.
- ❖ The cores of the other pair are used **jointly** for CAN-GND.
- ❖ The shield of the cable is led to the CAN shield connections for all nodes.
- ❖ For suitable and Metronix-recommended cables please refer to chapter 7.12.3 *Cable type and design*
- ❖ We advise against the use of plug adapters for CAN bus cabling. Should be necessary nonetheless, make sure to use metal connector housings to connect the cable shield.
- ❖ In order to keep interference's as low as possible make sure that
 - Motor cables are not installed parallel to signal lines.
 - Motor cables comply with Metronix specifications.
 - Motor cables are properly shielded and grounded.
 - Avoid the use of star-type wiring
- ❖ For further information on interference-free CAN bus cabling, please refer to the Controller Area Network protocol specification, Version 2.0 by Robert Bosch GmbH, 1991.

7.13 Connection: RS232/COM [X5]

7.13.1 Device side [X5]

- ❖ D-SUB connector, 9-pole, female

7.13.2 Counterplug [X5]

- ❖ D-SUB connector, 9-pole, male
- ❖ Housing for 9-pole D-SUB connector with bolting screws 4/40 UNC

7.13.3 Pin configuration [X5]

Table 34: Pin configuration RS232 interface [X5]

Pin No.	Denomination	Value	Specification
1	-	-	Not occupied
6	-	-	Not occupied
2	RxD	$10\text{ V} / R_T > 2\text{k}\Omega$	Receive line, RS232 specification
7	-	-	Not occupied
3	TxD	$10\text{ V} / R_A < 2\text{k}\Omega$	Transmitting line, RS232 specification
8	-	-	Not occupied
4	-	-	Not occupied
9	-	-	Not occupied
5	GND	0V	Interfaces GND, galvanically connected to GND DGND

7.13.4 Cable type and design [X5]

Interface cable for serial interface (null modem), 3-core.

7.13.5 Connection notes [X5]

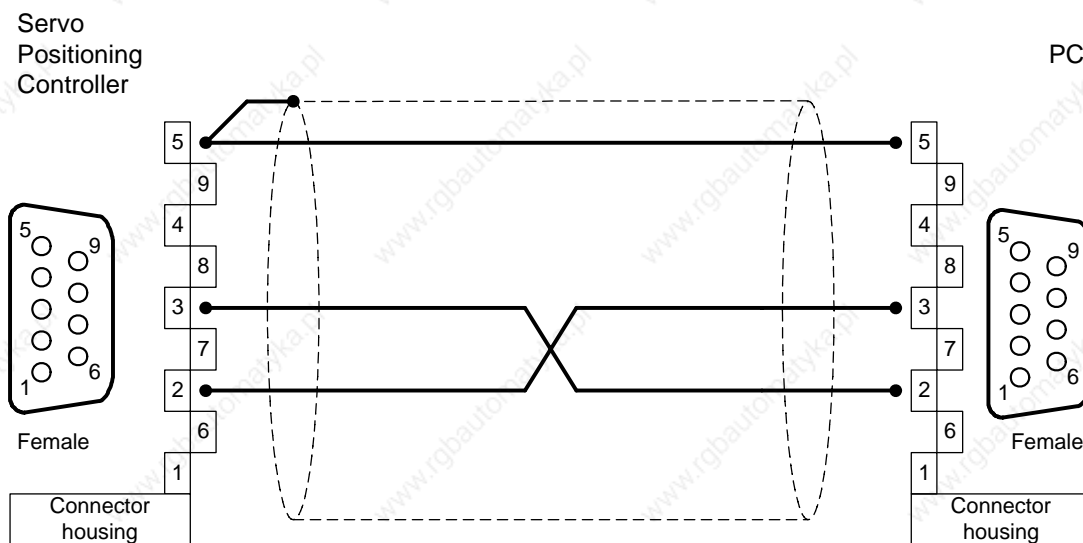

Figure 27: Pin configuration [X5]: RS232 null modem cable

8 Notes on safe and EMC-compliant installation

8.1 Definition and terms

Electromagnetic compatibility (EMC) or electromagnetic interference (EMI) includes the following requirements:

- ❖ Sufficient **immunity** of an electrical installation or an electrical device against outside electrical, magnetic or electromagnetic interference's via cables or the ambient.
- ❖ Sufficiently small **unwanted emission** of electrical, magnetic or electromagnetic interference from an electrical installation or an electrical device to other devices in the vicinity via cables or the ambient.

8.2 General information on EMC

The interference emission and interference immunity of a device always depend on the entire drive concept consisting of the following components:

- ❖ Voltage supply
- ❖ Servo positioning controller
- ❖ Motor
- ❖ Electromechanical
- ❖ Execution and type of wiring
- ❖ Superimposed control

In order to increase interference immunity and to decrease interference emissions the servo positioning controller ARS-310/xx already comprises output chokes and mains filters, so that it can be operated in most application without additional shielding and filtering devices.



The servo positioning controllers ARS-310/xx are certified as per the product standard EN 61800-3 for electrical drive systems.

In most cases no external filtering is required (see below).

The conformity certificate for EMC directive 89/336/EEC is available from the manufacturer.

8.3 EMC areas: first and second environment

Suitable installation and suitable wiring of all connection cables provided, the servo positioning controllers ARS-310/xx fulfill the requirements of the corresponding product standard EN 61800-3. This standard no longer refers to “classes” but so-called environments. The first environment includes mains supplies serving residential buildings and the second environment includes mains supplies exclusively serving industrial buildings.

The following applies for servo positioning controller, type ARS-310/xx:

Table 35: EMC requirements: First and second environment

EMC type	Area	Compliance with EMC requirements
Emitted interference	Second environment (industrial area)	Motor cable length up to 10m
	Second environment (industrial area)	Motor cable length up to 40m with usage of the EMC-Kit (see also chapter 8.5 Additional EMC equipment for operation with long motor cable, page 85)
Interference immunity	Second environment (industrial area)	Independent of the length of the motor cable

8.4 EMC-compliant cabling

The following must be considered for an EMC-compliant setup of the drive system (see also chapter 7 Electrical installation, page 53):

- ❖ The control cabinet bed plate must be conducting (zinc-coated design). The imperative central grounding point should also be located on the control cabinet bed plate.
- ❖ The signal lines must be as far away from the power cables as possible. They should not be placed parallel. If intersections cannot be avoided, they should be perpendicular (i.e. at a 90° angle), if possible.
- ❖ In order to keep the leakage currents and the losses in the motor connection cable as small as possible, the servo positioning controller ARS-310/xx should be located as close to the motor as possible (see also the following *chapter*).
- ❖ The shield of the motor cable is connected to the housing of the servo positioning controller ARS-310/xx (shield connection terminal, PE-screw). The shield of the motor cable also has to be connected to the control cabinet housing by means of metal cable glands.
- ❖ The mains-end PE connection is connected as the motor cable shield to the central PE connection point (PE-screw).
- ❖ The inner PE conductor of the motor cable is also connected to the PE point (PE-screw).

- ❖ Motor cable and angle encoder cable must be shielded.
- ❖ Unshielded signal and control lines should not be used. If their use is inevitable they should at least be twisted.
- ❖ Even shielded cables will inevitably have short unshielded ends (unless shielded connector housings are used). In general, the following applies:
 - Connect the inner shields to the corresponding pins of the connectors; Maximum length 40 mm.
 - Length of the unshielded cores 35 mm maximum.
 - Connect the total shield on the controller side plane to the PE terminal; Maximum length 40 mm.
 - Connect the total shield on the motor side plane to the connector housing or motor housing; Maximum length 40 mm.

**DANGER!**

For safety reasons, all PE ground conductors must be connected prior to initial operation.

The EN 50178 regulations for protective earthing must be complied with during installation!

8.5 Additional EMC equipment for operation with long motor cable

Servo controllers produce a pulse width modulated output voltage on its motor outlets by a pulsed IGBT inverter module. The edges of this motor outlet signal are very steep (approx. 5V/ns). All motor cable are characterized by a capacity between the conductors for the motor phases and the shield. So the steep edged motor outlet signal cause leakage currents in the shield which is connected to PE.

The leakage currents are the larger

- ❖ the larger the cable length is
- ❖ the larger the capacitance per unit length of the cable (unit of C': pF/m)

The leakage currents cause interference's in the encoder wiring, make the EMC behavior worse (emission of interference's into mains) and can result in the worst case in overload of some components of the servo positioning controller (e.g. EMC filters, current measuring modules etc.).

For the ARS-310/xx is mentioned:

- ❖ up to 10m motor cable length the internal EMC filters are sufficient

- ❖ for a motor cable length of more than 10m additional EMC equipment is necessary

Particularly in case of operation with high resolution incremental encoders, e. g. SINCOS encoders by Stegmann, YASKAWA encoders or Heidenhain incremental encoders it is essential to employ the EMC-Kit to provide undisturbed operation of the angle encoders.

Below the use of the EMC kit is described.

It is an external filtering measure, a so-called dU/dt motor filter, which reduces the steepness of the signal edges at the inverter outlet.

The permitted cable length and the capacitance per unit length for the different types of servo positioning controllers and the needed external measures you can be seen in the *Table 37, page 89* below.

8.5.1 Content of the EMC kit

Table 36: content of the EMC kit

1x	EMC kit complete with 2 toroidal cores suitable for applications with motor cable length till 40m:		Item No.: 9003-0253-10	
	Components:	1x		holding plate for 3 toroidal cores
		1x		shield terminal block
		2x		toroidal core R58 of ferrite material N30
		1x		shield terminal block SK20-D
		2x		screw M3*5
		2x		spring washer for M3
		4x		cable tie

8.5.2 External Cabling and Assembly

The following photo show the mounted EMC kit. An application with three toroidal cores can be seen.

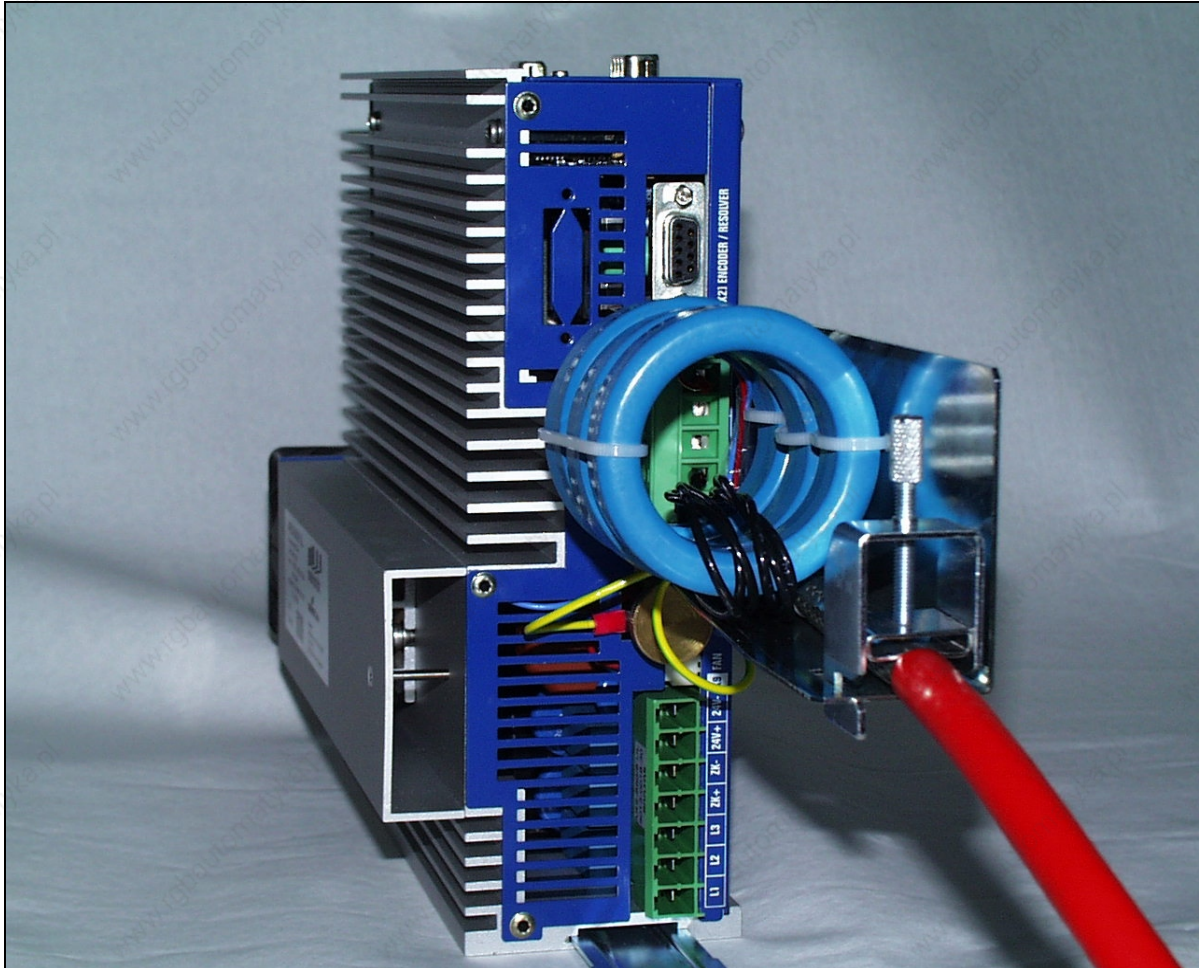

Figure 28: Mechanical installation: EMC kit with three toroidal cores

The motor cable has to be prepared in the following way:

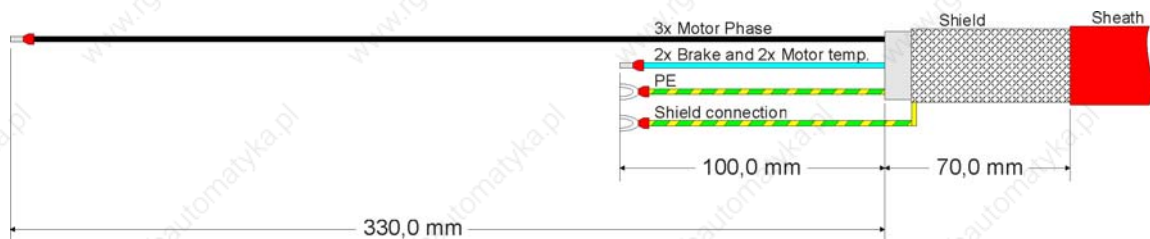

Figure 29: EMC kit: wiring length of the motor cable

With two toroidal cores the length of the motor phase conductors can be reduced to 260mm.

The following drawing show the dimension of the EMC holding plate:

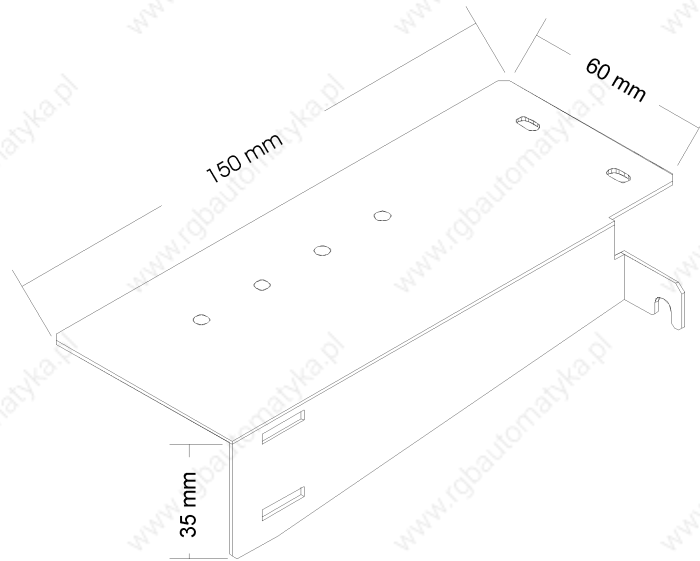

Figure 30: Mechanical dimension of the EMC holding plate

8.5.3 Assembly Instructions for the EMC Kit:

1. Attach the holding plate for the toroidal cores with the two screws M3*5 and the two spring washers to the ARS servo positioning controller. The contact plate of the plate has to be shifted underneath the PE terminal screw.
2. Attach the required number of toroidal cores to the holding plate with one cable tie per core (see chapter applications). On the opposite side the cores need to be fixed with a further cable tie.
3. Wind the three phase conductors of the prepared motor cable two times through the toroidal cores (see photo) and connect it to the motor connector X6.
4. The conductors for the motor temperature sensor and the holding brake must not be wound through the toroidal cores and feed directly to the motor connector X6.
5. The two PE conductors (motor PE and shield) must be connected to the PE terminal screw.
6. The shield of the motor cable is connected to the shield terminal block on the holding plate (see photo).

8.5.3.1 Alternative in case of restricted room

Applications in which the EMC Kit can not be used cause of restricted room, it is also possible to use the cores together with a modified motor cable.

1. The shield of the motor cables is modified by connecting it to of a wide copper tape (15mm - 20mm) and attach it to the PE screw.
2. The cores are tied together by use of cable ties
3. The motor phase wires fed to the ARS as shown in the previous photo
4. Take a mechanical fastening for the cores into account cause of the weight of the cores

8.5.4 EMC Kit applications

The following table shows the required additional equipment for the different servo positioning controllers and certain motor cable lengths:

Table 37: EMC-Components

Motor cable length in case of a capacitance per unit length of $C' \leq 250 \text{ pF/m}^{1)}$	EMC-Additional Components for the servo positioning controller ARS-310/xx	
	with resolver	high resolution encoder
$l \leq 10 \text{ m}$	---	---
$10 \text{ m} < l \leq 40 \text{ m}$	---	EMC-Kit (9003-0253-10)



- 1) Maximum capacitance per unit length of a single motor phase conductor against PE. The filter is designed for a maximum cable capacitance of $C_{\text{Cabel}} = l \times C' = 10\text{nF}$.

Therefore cable types with $C' < 200\text{pF/m}$ are required at a motor cable length of 50m!

8.6 ESD protection



Unassigned D-Sub connectors may cause damage to the device or other parts of the systems due to ESD (electrostatic discharge)



To prevent such discharge, protective caps are available (e.g. Spoerle).

The servo positioning controller ARS-310/xx has been designed to provide high interference immunity. For that reason, some individual functional blocks are electrically isolated. Inside the device the signals are transmitted via optocouplers.

The following isolated areas are distinguished:

- ❖ Power stage with DC bus and mains input
- ❖ Control electronics with processing of analogue signals
- ❖ 24V supply and digital inputs and outputs

9 Initial operation

9.1 General notes on connection



Since the laying of the connection cables is very important in terms of EMC, make sure to comply with the previous *chapter 8.4 EMC-compliant cabling (page 84)*!



DANGER!

Noncompliance with *chapter 2 Safety notes for electrical drives and controllers (page 14)* may result in property damage, person injury, electric shock or in extreme cases in death.

9.2 Tools / material

- ❖ Screwdriver for slotted head screws size 1
- ❖ Serial interface cable
- ❖ Angle encoder cable
- ❖ Motor cable
- ❖ Power supply cable
- ❖ Controller enabling cable

9.3 Connecting the motor

- ❖ Plug the connector of the motor cable into the corresponding socket of the motor and screw tight.
- ❖ Plug PHOENIX connector into socket **[X6]** of the device.
- ❖ Connect the PE line of the motor to the **PE** socket.
- ❖ Plug the connector of the encoder cable into the encoder output socket of the motor and screw tight.
- ❖ Plug the D-Sub connector into the socket **[X2] Resolver** or **[X21] Encoder** of the device and fasten the bolting screws.
- ❖ Check all connections again.

9.4 Connecting the servo positioning controller ARS-310/xx to the power supply

- ❖ Make sure that the power supply has been switched off.
- ❖ Plug the PHOENIX connector into socket **[X9]** of the device.
- ❖ Connect the PE line of the mains to the **PE** socket.
- ❖ Connect the 24V connections to a suitable power supply unit.
- ❖ Make mains supply connections.
- ❖ Check all connections again.

9.5 Connecting the PC

- ❖ Plug the D-Sub connector of the serial interface cable into the socket for the serial interface of the PC and fasten the bolting screws.
- ❖ Plug the D-Sub connector of the serial interface cable into the socket **[X5] RS232/COM** of the servo positioning controller ARS-310/xx and fasten the bolting screws.
- ❖ Check all connections again.

9.6 Checking operability

1. Make sure the controller enabling switch is turned off.
2. Switch on the power supply of all devices. The READY-LED on the front of the device should now be active.

If the READY-LED is not active, there is a malfunction. If the seven-segment display indicates a number sequence, it is displaying an error message. You have to take care of the corresponding problem. In this case please continue with *chapter 10.2.2 Error messages (page 95)*. If the device displays nothing, follow these steps:

1. Switch off the power supply.
2. Wait 5 minutes, so the DC bus can discharge.
3. Check all connection cables.
4. Check the functionality of the 24 V power supply.
5. Switch the power supply back on.

10 Service functions and error messages

10.1 Protection and service functions

10.1.1 Overview

The servo positioning controller ARS-310/xx has a powerful sensor analysis, which monitors the proper functioning of the controller, power output stage, motor and communication with the outside world. All occurring errors are stored in an internal error memory. Most errors will cause the controller unit to shut down the servo positioning controller and the power output stage. They can only be switched on again after the error memory has been deleted by acknowledging the error and after the error has been eliminated or no longer exists.

A powerful sensor analysis and monitoring function provides operational safety:

- ❖ Measuring of motor temperature
- ❖ Measuring of power section temperature
- ❖ Detection of ground faults (PE)
- ❖ Detection of connections between two motor phases
- ❖ Detection of overvoltage in the DC bus
- ❖ Detection of errors with the internal voltage supply

10.1.2 Overcurrent and short-circuit monitoring

This monitor responds as soon as the current in the DC bus exceeds twice the maximum current of the controller. It detects short-circuits between two motor phases as well as short-circuits at the motor output terminals against the positive and negative reference potential of the DC bus and against PE. If the error monitoring detects an overcurrent, the power output stage will shut down immediately to guarantee the ability to withstand short-circuits.

10.1.3 Overvoltage monitoring for the DC bus

This monitor responds, if the DC bus voltage exceeds the operating voltage range. The power output stage will be shut down.

10.1.4 Temperature monitoring of the heat sink

The heat sink temperature of the power output stage is measured with a linear temperature sensor. The temperature limit varies from device to device. Approx. 5°C underneath the limit value a temperature warning is issued.

10.1.5 Monitoring of the motor

The servo positioning controller ARS-310/xx has the following protective functions to monitor the motor and the connected encoder:

Monitoring of the encoder: An error in the shaft encoder shuts down the power output stage. In the case of resolvers, e.g. the encoder signal is monitored. In the case of incremental encoders the commutation signals are checked. Other „intelligent“ encoders provide further means of error detection

Measurement and monitoring of the motor temperature: The servo positioning controller ARS-310/xx has a two inputs for the detection and monitoring of the motor temperature. The following inputs for temperature sensors can be chosen:

At [X6]: Digital input for PTCs, normally closed contacts and normally open contacts.

At [X2] and [X21]: Digital input for PTCs, normally closed contacts and normally open contacts.

10.1.6 I²t monitoring

The servo positioning controller ARS-310/xx comprises an I²t monitoring to limit the average power loss in the power output stage and in the motor. Since the occurring power loss in the power electronics and in the motor in the worst case increases square with the current, the squared current value is assumed as the measure for the power loss.

10.1.7 Power monitoring for the brake chopper

Power monitoring for the internal brake resistor is implemented in the servo positioning controller.

10.1.8 Initial operation status

Servo positioning controller, which are sent to Metronix for service, will be equipped with a different firmware and other parameters for testing purposes.

Before the next initial operation at the consumer the servo positioning controller ARS-310/xx must be parameterized again. The parameterization software WMEMOC 3.5 GAMMA queries the initial operation status and asks the user to parameterize the servo positioning controller. At the same time the device shows an “A” on the seven-segment display to indicate that the servo is running but not yet parameterized.

10.2 Display of operating mode and error messages

10.2.1 Display of operating mode and errors

A seven-segment display is supported. The following table shows the displayed symbols and their meaning:

Table 38: Display of operating mode and errors

Display	Meaning
-	Center bar of seven-segment display: Speed-controlled or torque controlled (in this modes of operation, an additional bar rotates around the center bar, indicating the position of the rotor)
A	The servo positioning controller ARS-310/xx is yet to be parameterized
L	Position-controlled operating mode but without having the profile generation engaged
LS	Position-controlled operating mode but without having the profile generation engaged but with synchronous mode
P	Profile Position mode
PS	Position-controlled operating mode with having the profile generation engaged an synchronous mode
P xx	Positioning (“xx” stands for pos. no.) The numbers are successively indicated
xx	Error with index “xx”

10.2.2 Error messages

If an error occurs, the servo positioning controller ARS-310/xx will cyclically show an error message in its seven-segment display. The error message is comprised of a two character index e.g.: **07**.

The characters are shown in a sequence with a short pause between the characters and a long pause at the end of the sequence consisting out of the two characters.

The following Table 39 summarizes the meaning and corresponding measures:

Table 39: Error messages

Mainindex	Meaning of error message	Measures
01	Stack overflow	Wrong firmware? Reload standard firmware, if necessary Contact Technical Support
02	Undervoltage in DC bus	Check DC bus voltage (measure) Adjust configuration
03	Overtemperature motor	Right sensor? Sensor defective? Error also occurs if sensor is by-passed: device defective. Motor too hot? Check parameterisation (current controller, current limit)
04	Overtemperature power section	Temperature display plausible? Check installation conditions, filter mats of ventilator dirty? Device ventilator defective?
05	Failure of internal voltage	Error cannot be fixed by user. Send servo positioning controller to sales representative.
06	Short-circuit output stage	Output stage defective? Motor defective? Short-circuit in cable?
07	Overvoltage	Check connection to brake resistor (internally / externally) Brake resistor overloaded? Check dimensioning.
08	Angle encoder error resolver	Angle encoder connected? Angle encoder cable defective? Angle encoder defective? Check configuration of angle encoder interface
	Error encoder signal Z0 incremental encoder	Angle encoder connected? Angle encoder cable defective?
	Error encoder signals Z1 incremental encoder	Angle encoder defective? Check configuration of angle encoder interface
	Error encoder signals digital incremental encoder	Encoder signals disturbed: check installation regarding EMC

Mainindex	Meaning of error message	Measures
	Error hall sensor signals incremental encoder	recommendations.
10	Actual speed higher then maximum speed	speed protection is active, if necessary it should be adjusted
11	Error in homing run	homing is not working, wrong direction (limit switch), check methods Controller enable is missing (if start by field bus is regarded) power stage enable is missing
12	Bus- error	the used field bus is not active, no bus-master in the system Master is activated to late Datarate, wires not correct Termination resistors wrong
14	Automatic angle detection error	encoder defective motor shaft could not be moved To small motor current parameterised, motor blocked
15	Division by zero	Problems in parameter set, for instance new download or new realisation of the parameter set is necessary Reload of firmware, wrong firmware Gearing factors not correct
16	Error in program execution	Please contact the technical support.
17	Limit values exceeded lag error	to big difference between setpoint and actual position Check load of the drive Increase configuration Acceleration parameterised too large
18	Error in position profile pre-computation	check position parameter set
20	Error in encoder input	Check counts per revolution check the wiring
21	Error current measurement	Error cannot be fixed by user. Send servo positioning controller to sales representative.
23	fieldbus node two times in the network	Check fieldbus setup

Mainindex	Meaning of error message	Measures
24	fieldbus node-guarding in operation	node-guarding needs to be checked check wiring
25	Invalid device type	Error cannot be fixed by user. Send servo positioning controller to sales representative.
26	Flash-memory: Missing user parameter set	Load default parameter set. If the error still exists, send servo positioning controller to sales representative.
27	Flash-memory: Check sum error	Flash-memory is not ok reload firmware and parameter set-up Please contact the technical support.
28	Flash-memory: write error	Flash-memory is not ok reload firmware and parameter setup Please contact the technical support.
30	error in computation factors	change factor for the gearing
31	I ² t motor	motor blocked
	I ² t servo positioning controller	Check power dimensioning of drive package.

11 Information concerning UL

In respect to the UL approval of the ARS-310/5 (UL) further information are given in this chapter.

- The ARS-310/5 (UL) is listed according to UL508C, File E219816

11.1 Circuit protection

Branch Circuit Protection has to be provided in the field. The following fuse sizes shall be used.

- ❖ 16 Amp for ARS-310/5 (UL)

11.2 Wiring and environment regards

Use 60/75 or 75°C copper (CU) wire only.

The terminal tightening torque is 0.5...0.6 Nm.

To be used in a Pollution Degree 2 environment only.

11.2.1 Motor and mains supply and sensor wiring according to AWG

In the following an overview according to the regarded AWG wire types are given.

- ❖ Use AWG 15 for the power supply wiring ([X9])
- ❖ Use AWG 15 (shielded) for the motor supply wiring ([X6])
- ❖ Use AWG 23 for the control wiring ([X1])
- ❖ Use AWG 25 for the RS232 interface wiring ([X5])
- ❖ Use AWG 25 (signal wiring) combined with AWG 20 for the encoder power supply wiring ([X2], [X10], [X11] and [X21])

11.3 Overload behaviour

To ensure the Internal Overload Protection operates at 225% of the Motor Full Load Current after 10 seconds make sure that the motor is properly parameterised according to chapter 5.2.x configuration of motor specification in Software Manual WMEMOC 3.5 "Servo Positioning Controller ARS-310, ARS-560, IMD-310/5 F".