

# BMH

Servo motor  
Motor manual  
V1.04, 10.2012

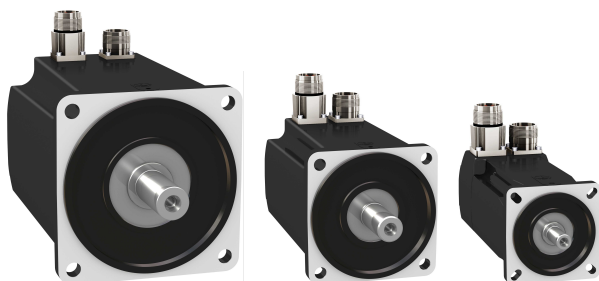

---

## Important information

This manual is part of the product.

Carefully read this manual and observe all instructions.

Keep this manual for future reference.

Hand this manual and all other pertinent product documentation over to all users of the product.

Carefully read and observe all safety instructions as well as chapter "2 Before you begin - safety information".

Some products are not available in all countries.

Please consult the latest catalog for information on the availability of products.

Subject to technical modifications without notice.

All details provided are technical data which do not constitute warranted qualities.

Most of the product designations are registered trademarks of their respective owners, even if this is not explicitly indicated.

# Table of contents

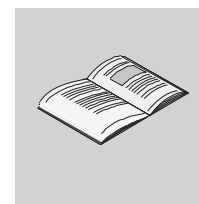

	<b>Important information</b> .....	<b>2</b>
	<b>Table of contents</b> .....	<b>3</b>
	<b>About this manual</b> .....	<b>7</b>
<b>1</b>	<b>Introduction</b> .....	<b>9</b>
	1.1 Motor family.....	9
	1.2 Options and accessories .....	10
	1.3 Nameplate.....	11
	1.4 Type code.....	12
<b>2</b>	<b>Before you begin - safety information</b> .....	<b>13</b>
	2.1 Qualification of personnel.....	13
	2.2 Intended use .....	13
	2.3 Hazard categories .....	14
	2.4 Basic information.....	15
	2.5 Standards and terminology.....	17
<b>3</b>	<b>Technical Data</b> .....	<b>19</b>
	3.1 General features.....	19
	3.2 Motor-specific data.....	22
	3.2.1 BMH070.....	22
	3.2.2 BMH100.....	24
	3.2.3 BMH140.....	26
	3.2.4 BMH190.....	28
	3.2.5 BMH205.....	29
	3.3 Dimensions .....	31
	3.4 Shaft-specific data.....	36
	3.4.1 Force for pressing on.....	36
	3.4.2 Shaft load .....	37
	3.5 Options .....	39
	3.5.1 Holding brake.....	39
	3.5.2 Encoder .....	40
	3.6 Conditions for UL 1004 .....	41
	3.7 Certifications .....	41
	3.8 Declaration of conformity.....	42
<b>4</b>	<b>Installation</b> .....	<b>43</b>

019844113749, V1.04, 10.2012

4.1	Overview of procedure.....	45
4.2	Electromagnetic compatibility, EMC.....	45
4.3	Before mounting.....	47
4.4	Mounting the motor.....	52
4.4.1	Installation and connection of IP67 kit (accessory).....	56
4.5	Electrical installation.....	58
4.5.1	Connectors and connector assignments.....	58
4.5.2	Power and encoder connection.....	62
4.5.3	Holding brake connection.....	68
<b>5</b>	<b>Commissioning.....</b>	<b>69</b>
<b>6</b>	<b>Diagnostics and troubleshooting.....</b>	<b>71</b>
6.1	Mechanical problems.....	71
6.2	Electrical problems.....	71
<b>7</b>	<b>Accessories and spare parts.....</b>	<b>73</b>
7.1	IP67 Kit.....	73
7.2	Connectors.....	73
7.3	Motor cables.....	74
7.3.1	Motor cables 1.5 mm <sup>2</sup> .....	74
7.3.2	Motor cables 2.5 mm <sup>2</sup> .....	75
7.3.3	Motor cables 4 mm <sup>2</sup> .....	76
7.3.4	Motor cables 6 mm <sup>2</sup> .....	77
7.3.5	Motor cables 10 mm <sup>2</sup> .....	78
7.4	Encoder cables.....	79
<b>8</b>	<b>Service, maintenance and disposal.....</b>	<b>81</b>
8.1	Service address.....	81
8.2	Storage.....	81
8.3	Maintenance.....	81
8.4	Changing the motor.....	83
8.5	Shipping, storage, disposal.....	83
<b>9</b>	<b>Glossary.....</b>	<b>85</b>
9.1	Units and conversion tables.....	85
9.1.1	Length.....	85
9.1.2	Mass.....	85
9.1.3	Force.....	85
9.1.4	Power.....	85
9.1.5	Rotation.....	86
9.1.6	Torque.....	86
9.1.7	Moment of inertia.....	86
9.1.8	Temperature.....	86
9.1.9	Conductor cross section.....	86
9.2	Terms and Abbreviations.....	87

**10 Table of figures..... 89**

**11 Index ..... 91**



## About this manual

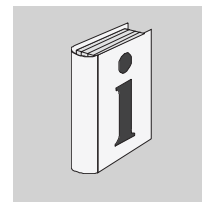

This manual is valid for BMH standard products. Chapter "1 Introduction" lists the type code for this product. The type code allows you to identify whether your product is a standard product or a customized version.

*Source manuals* The latest versions of the manuals can be downloaded from the Internet at:

<http://www.schneider-electric.com>

*Corrections and suggestions* We always try to further optimize our manuals. We welcome your suggestions and corrections.

Please get in touch with us by e-mail:

[techcomm@schneider-electric.com](mailto:techcomm@schneider-electric.com).

*Work steps* If work steps must be performed consecutively, this sequence of steps is represented as follows:

- Special prerequisites for the following work steps
  - ▶ Step 1
  - ◁ Specific response to this work step
  - ▶ Step 2

If a response to a work step is indicated, this allows you to verify that the work step has been performed correctly.

Unless otherwise stated, the individual steps must be performed in the specified sequence.

*Making work easier* Information on making work easier is highlighted by this symbol:



*Sections highlighted this way provide supplementary information on making work easier.*

*SI units* SI units are the original values. Converted units are shown in brackets behind the original value; they may be rounded.

Example:

Minimum conductor cross section: 1.5 mm<sup>2</sup> (AWG 14)

*Glossary* Explanations of special technical terms and abbreviations.

*Index* List of keywords with references to the corresponding page numbers.





# 1 Introduction

# 1

## 1.1 Motor family

The motors are AC synchronous servo motors with a very high power density. A drive system consists of the AC synchronous servo motor and the appropriate drive. Maximum performance requires the motor and drive to be adapted to each other.

*Features* The AC synchronous servo motors excel with:

- High power density: the use of the latest magnetic materials and an optimized design result in motors with a shorter length at a comparable torque.
- High peak torque: the peak torque can be up to four times the continuous stall torque

## 1.2 Options and accessories

The motors are available with various options such as:

- Various encoder systems
- Holding brake
- Various shaft versions
- Various degrees of protection
- Various lengths
- Various sizes
- Various winding versions

The options can be found in the type code section on page 12.

For accessories see chapter "7 Accessories and spare parts", page 73.

Gearboxes adapted to the motor can be found in the Lexium 32 product catalog.

### 1.3 Nameplate

The nameplate contains the following data:

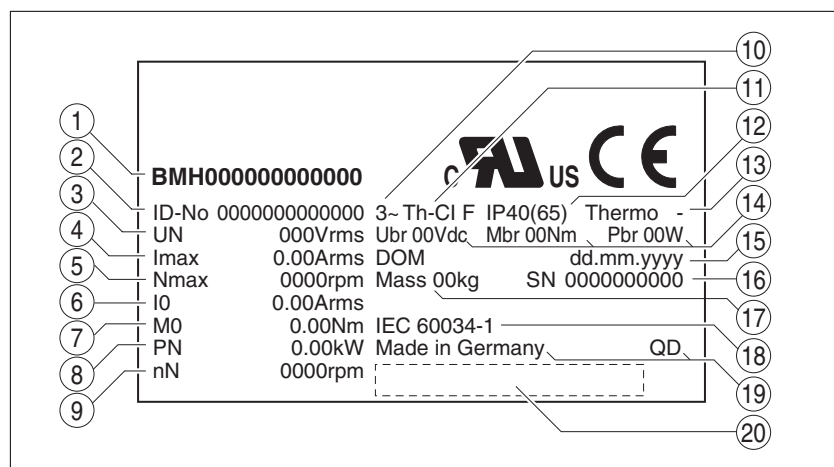

Figure 1: Nameplate

- (1) Motor type, see type code
- (2) Identification number
- (3) Maximum nominal value of supply voltage
- (4) Maximum current
- (5) Maximum speed of rotation
- (6) Continuous stall current
- (7) Continuous stall torque
- (8) Nominal power
- (9) Nominal speed of rotation
- (10) Number of motor phases
- (11) Thermal class
- (12) Degree of protection (housing without shaft bushing)
- (13) Temperature sensor
- (14) Holding brake data
- (15) Date of manufacture
- (16) Serial number
- (17) Mass of the motor
- (18) Applied standard
- (19) Country of manufacture, site
- (20) Barcode

1.4 Type code

	<b>BMH</b>	<b>070</b>	<b>1</b>	<b>P</b>	<b>0</b>	<b>1</b>	<b>A</b>	<b>1</b>	<b>A</b>
<b>Product family</b> BMH: Synchronous motor - medium moment of inertia									
<b>Size (housing)</b> 070 = 70 mm flange 100 = 100 mm flange 140 = 140 mm flange 190 = 190 mm flange 205 = 205 mm flange									
<b>Length</b> 1 = 1 stack 2 = 2 stacks 3 = 3 stacks									
<b>Winding</b> P = Optimized in terms of torque and speed of rotation T = Optimized in terms of high speed of rotation									
<b>Shaft and degree of protection</b> 0 = Smooth shaft <sup>1)</sup> ; degree of protection: shaft IP54 <sup>2)</sup> , housing IP65 1 = Parallel key <sup>1)</sup> ; degree of protection: shaft IP 54 <sup>2)</sup> , housing IP 65 2 = Smooth shaft; degree of protection: shaft and housing IP65 <sup>2) 3)</sup> 3 = Parallel key; degree of protection: shaft and housing IP 65 <sup>2) 3)</sup>									
<b>Encoder system</b> 1 = Absolute singleturn 128 Sin/Cos periods per revolution (SKS36) 2 = Absolute multiturn 128 Sin/Cos periods per revolution (SKM36) 6 = Absolute singleturn 16 Sin/Cos periods per revolution (SEK37) 7 = Absolute multiturn 16 Sin/Cos periods per revolution (SEL37)									
<b>Holding brake</b> A = Without holding brake F = With holding brake									
<b>Connection version</b> 1 = Straight connector <sup>1)</sup> 2 = Angular connector 90°, can be rotated									
<b>Mechanical interface - mounting</b> A = International IEC Standard									

1) Not for size 190  
 2) In the case of mounting position IM V3 (drive shaft vertical, shaft end up), the motor only has degree of protection IP50.  
 3) The maximum permissible speed of rotation is limited to 6000 min<sup>-1</sup> by the shaft sealing ring. Separate accessories allow you to obtain degree of protection IP67. See chapter "7 Accessories and spare parts".

If you have questions concerning the type code, contact your Schneider Electric sales office.

*Designation customized version* In the case of a customized version, position 8 of the type code is an "S". The subsequent number defines the customized version. Example: B.....S1234

Contact your machine vendor if you have questions concerning customized versions.

## 2 Before you begin - safety information

# 2

### 2.1 Qualification of personnel

Only appropriately trained persons who are familiar with and understand the contents of this manual and all other pertinent product documentation are authorized to work on and with this product. In addition, these persons must have received safety training to recognize and avoid hazards involved. These persons must have sufficient technical training, knowledge and experience and be able to foresee and detect potential hazards that may be caused by using the product, by changing the settings and by the mechanical, electrical and electronic equipment of the entire system in which the product is used.

All persons working on and with the product must be fully familiar with all applicable standards, directives, and accident prevention regulations when performing such work.

### 2.2 Intended use

This product is a motor and intended for industrial use according to this manual.

The product may only be used in compliance with all applicable safety regulations and directives, the specified requirements and the technical data.

Prior to using the product, you must perform a risk assessment in view of the planned application. Based on the results, the appropriate safety measures must be implemented.

Since the product is used as a component in an entire system, you must ensure the safety of persons by means of the design of this entire system (for example, machine design).

Operate the product only with the specified cables and accessories. Use only genuine accessories and spare parts.

The product must NEVER be operated in explosive atmospheres (hazardous locations, Ex areas).

Any use other than the use explicitly permitted is prohibited and can result in hazards.

Electrical equipment should be installed, operated, serviced, and maintained only by qualified personnel.

## 2.3 Hazard categories

Safety instructions to the user are highlighted by safety alert symbols in the manual. In addition, labels with symbols and/or instructions are attached to the product that alert you to potential hazards.

Depending on the seriousness of the hazard, the safety instructions are divided into 4 hazard categories.

### **DANGER**

DANGER indicates an imminently hazardous situation, which, if not avoided, **will result** in death or serious injury.

### **WARNING**

WARNING indicates a potentially hazardous situation, which, if not avoided, **can result** in death, serious injury, or equipment damage.

### **CAUTION**

CAUTION indicates a potentially hazardous situation, which, if not avoided, **can result** in injury or equipment damage.

### **NOTICE**

NOTICE indicates a potentially hazardous situation, which, if not avoided, **can result** in equipment damage.

## 2.4 Basic information

### **DANGER**

#### **HAZARD OF ELECTRIC SHOCK, EXPLOSION OR ARC FLASH**

- Only appropriately trained persons who are familiar with and understand the contents of this manual and all other pertinent product documentation and who have received safety training to recognize and avoid hazards involved are authorized to work on and with this drive system. Installation, adjustment, repair and maintenance must be performed by qualified personnel.
- The system integrator is responsible for compliance with all local and national electrical code requirements as well as all other applicable regulations with respect to grounding of all equipment.
- Supplement the motor cable grounding conductor with an additional protective ground conductor to the motor housing.
- Do not touch unshielded components or terminals with voltage present. Use only electrically insulated tools.
- The motor generates voltage when the shaft is rotated. Prior to performing any type of work on the drive system, block the motor shaft to prevent rotation.
- AC voltage can couple voltage to unused conductors in the motor cable. Insulate both ends of unused conductors in the motor cable.
- Do not short across the DC bus terminals or the DC bus capacitors.
- Before performing work on the drive system:
  - Disconnect all power, including external control power that may be present.
  - Place a "Do Not Turn On" label on all power switches.
  - Lock all power switches in the open position.
  - Wait for the DC bus capacitors to discharge (see the product manual for the power stage). Then measure the DC bus voltage and verify it is less than  $< 42 V_{dc}$  (see the product manual for the power stage).
- Install and close all covers before applying voltage.

**Failure to follow these instructions will result in death or serious injury.**

**▲ WARNING****MOVEMENT WITHOUT BRAKING EFFECT**

If power outage, functions or errors cause the power stage to be switched off, the motor is no longer decelerated in a controlled way. Overload or errors can cause hazards due to the failure of the holding brake. Incorrect use of the holding brake results in premature wear and failure.

- Secure the hazardous area so it cannot be accessed.
- Verify the function of the holding brake at regular intervals.
- Do not use the holding brake as a service brake.
- If necessary, use a cushioned mechanical stop or a suitable brake.

**Failure to follow these instructions can result in death, serious injury or equipment damage.**

**▲ WARNING****LOSS OF CONTROL**

- The designer of any control scheme must consider the potential failure modes of control paths and, for certain critical functions, provide a means to achieve a safe state during and after a path failure. Examples of critical control functions are emergency stop, overtravel stop, power outage and restart.
- Separate or redundant control paths must be provided for critical functions.
- System control paths may include communication links. Consideration must be given to the implication of unanticipated transmission delays or failures of the link.
- Observe all accident prevention regulations and local safety guidelines.<sup>1)</sup>
- Each implementation of the product must be individually and thoroughly tested for proper operation before being placed into service.

**Failure to follow these instructions can result in death or serious injury.**

1) For USA: Additional information, refer to NEMA ICS 1.1 (latest edition), "Safety Guidelines for the Application, Installation, and Maintenance of Solid State Control" and to NEMA ICS 7.1 (latest edition), "Safety Standards for Construction and Guide for Selection, Installation and Operation of Adjustable-Speed Drive Systems".



## 2.5 Standards and terminology

Technical terms, terminology and the corresponding descriptions in this manual are intended to use the terms or definitions of the pertinent standards.

In the area of drive systems, this includes, but is not limited to, terms such as "safety function", "safe state", "fault", "fault reset", "failure", "error", "error message", "warning", "warning message", etc.

Among others, these standards include:

- IEC 61800: "Adjustable speed electrical power drive systems"
- IEC 61158: "Digital data communications for measurement and control – Fieldbus for use in industrial control systems"
- IEC 61784: "Industrial communication networks – Profiles"
- IEC 61508: "Functional safety of electrical/electronic/programmable electronic safety-related systems"

Also see the glossary at the end of this manual.



### 3 Technical Data

# 3

This chapter contains information on the ambient conditions and on the mechanical and electrical properties of the product family and the accessories.

#### 3.1 General features

Motor type	AC synchronous servo motor	
Number of pairs of poles	5	
Degree of protection motor housing	IP65	As per IEC 60034-5
Degree of protection shaft bushing without shaft sealing ring	IP54 <sup>2)</sup>	As per IEC 60034-5
Degree of protection shaft bushing with shaft sealing ring	IP65 <sup>1) 2)</sup>	As per IEC 60034-5
Degree of protection with IP67 kit	IP67 <sup>2)</sup>	As per IEC 60034-5
Thermal class	F (155 C°)	As per IEC 60034-1
Vibration grade	A	As per IEC 60034-14
Test voltage	> 2400 V <sub>ac</sub>	As per IEC 60034-1
Maximum permissible winding voltage	BMH••••T 240 V <sub>ac</sub> BMH••••P 480 V <sub>ac</sub>	
Maximum voltage to ground	280 V <sub>ac</sub>	
Perpendicularity	normal class	As per IEC 60072-1, DIN 42955
Housing color	Black RAL 9005	
Overvoltage category	III	As per IEC 61800-5-1
Protection class <sup>3)</sup>	I	As per IEC 61140, EN 50178

- 1) With shaft sealing ring: the maximum speed of rotation is limited to 6000 min<sup>-1</sup>; shaft sealing ring with initial lubrication, if the seal runs dry, this increases friction and reduces service life.
- 2) In the case of mounting position IM V3 (drive shaft vertical, shaft end up), the motor only has degree of protection IP50. The degree of protection only relates to the motor itself, not to mounted components such as, for example, a gearbox.
- 3) The signals of the holding brake at CN1 and the signals at CN2 meet the PELV requirements.

The motor has been tested for compatibility with external substances according to the latest knowledge. However, it is impossible to follow up on all further developments of all substances such as lubricants or cleaning agents. Therefore, you must perform a compatibility test prior to using new substances.

#### *Climatic environmental conditions transportation and storage*

The environment during transportation and storage must be dry and free from dust.

The storage time is primarily limited by the service life of the lubricants in the bearings; do not store the product for more than 36 months. It is recommended to periodically operate the motor. Long storage periods may reduce the holding torque of the holding brake. See "Checking/running in the holding brake" in chapter "8 Service, maintenance and disposal".

Temperature	[°C]	-40 ... 70
Relative humidity (non-condensing)	[%]	≤75
Set of class combinations as per IEC 60721-3-2		IE 21

*Climatic environmental conditions operation*

Ambient temperature <sup>1)</sup> (no icing, non-condensing)	[°C]	-20 ... 40
Ambient temperature with current reduction of 1% per °C <sup>1)</sup>	[°C]	40 ... 60
Relative humidity (non-condensing)	[%]	5 ... 85
Class as per IEC 60721-3-3		3K3, 3Z12, 3Z2, 3B2, 3C1, 3M6
Installation altitude <sup>2)</sup>	[m]	≤1000
Installation altitude with current reduction of 1% per 100 m at altitudes of more than 1000 m <sup>2)</sup>	[m]	1000 ... 3000

- 1) Limit values with flanged motor (steel plate, height and width = 2.5 \* motor flange, 10 mm thickness, centered hole.)  
 2) The installation altitude is defined as altitude above mean sea level.

*Vibration and shock BMH070 ... 190*

Vibration, sinusoidal	Type test with 10 runs as per IEC 60068-2-6 0.15 mm (von 10 Hz ... 60 Hz) 20 m/s <sup>2</sup> (from 60 Hz ... 500 Hz)
Shock, semi-sinusoidal	Type test with 3 shocks in each direction as per IEC 60068-2-27 150 m/s <sup>2</sup> (11 ms)

*Vibration and shock BMH205*

Vibration, sinusoidal	Type test with 10 runs as per IEC 60068-2-6 0.35 mm (von 10 Hz ... 60 Hz) 50 m/s <sup>2</sup> (from 60 Hz ... 150 Hz)
Shock, semi-sinusoidal	Type test with 3 shocks in each direction as per IEC 60068-2-27 200 m/s <sup>2</sup> (6 ms)

*Service life*

Nominal bearing service life L <sub>10h</sub> <sup>1)</sup>	h	20000
---	---	-------

- 1) Operating hours at a probability of failure of 10%

The service life of the motors when operated correctly is limited primarily by the service life of the rolling bearing.

The following operating conditions significantly reduce the service life:

- Installation altitude >1000 m above m.s.l.
- Rotary movements exclusively within a fixed angle of <100°
- Operation under vibration load >20 m/s<sup>2</sup>
- Allowing sealing rings to run dry
- Contact of the seals with aggressive media

*Shaft sealing ring / degree of protection*

The motors can be equipped with an optional shaft sealing ring. With a shaft sealing ring, they have degree of protection IP65. The shaft sealing ring limits the maximum speed of rotation to 6000 min<sup>-1</sup>.

Note the following:

- The shaft sealing ring is factory-pre-lubricated.
- If the seals run dry, this increases friction and greatly reduces the service life of the sealing rings.

*Compressed air connection*

Compressed air must also be available when the system is switched off, for example to maintain the required degree of protection during cleaning work. When the compressed air is switched off, the degree of protection is lost. The degree of protection only relates to the motor itself, not to mounted components such as, for example, a gearbox.

Special compressed air must be used:

Nominal pressure	[bar] [PSI]	0.1 ... 0.3 (1.45 ... 4.35)
Maximum air pressure	[bar] [PSI]	0.4 (5.8)
Permissible humidity	[%]	20 ... 30
Other properties of the compressed air		Free from dust, free from oil

*Tightening torque and property class of screws used*

Tightening torque of housing screws M3	[Nm] (lb•in)	1 (8.85)
Tightening torque of housing screws M4	[Nm] (lb•in)	1.5 (13.28)
Tightening torque of housing screws M5	[Nm] (lb•in)	5 (44.3)
Tightening torque protective ground conductor M4 (BMH055 ... 140)	[Nm] (lb•in)	2.9 (25.7)
Tightening torque protective ground conductor M6 (BMH205)		9.9 (87.3)
Property class of the screws	H	8.8

Table 1: Tightening torques and property classes

*Approved drives*

You may use drives that are approved for the BMH motor family (for example, LXM32). When selecting, consider the type and amount of the mains voltage. Inquire for additional drives that can be used to operate BMH motors. Note that the BMH motor does not have a conventional temperature sensor.

## 3.2 Motor-specific data

## 3.2.1 BMH070

Motor type			BMH0701	BMH0701	BMH0702	BMH0702	BMH0703	BMH0703
Winding			P	T	P	T	P	T
<b>Technical data - general</b>								
Continuous stall torque <sup>1)</sup>	M <sub>0</sub> <sup>2)</sup>	[Nm]	1.40	1.40	2.48	2.48	3.40	3.40
Peak torque	M <sub>max</sub>	[Nm]	4.20	4.20	7.44	7.44	10.20	10.20
With supply voltage U <sub>n</sub> = 115 V <sub>ac</sub> <sup>1)</sup>								
Nominal speed of rotation	n <sub>N</sub>	[min <sup>-1</sup> ]	1250	2500	1250	2500	1250	2000
Nominal torque	M <sub>N</sub>	[Nm]	1.38	1.35	2.37	2.27	3.18	3.05
Nominal current	I <sub>N</sub>	[A <sub>rms</sub> ]	1.75	2.75	2.82	4.92	3.56	4.98
Nominal power	P <sub>N</sub>	[kW]	0.18	0.35	0.31	0.59	0.42	0.64
With supply voltage U <sub>n</sub> = 230 V <sub>ac</sub> <sup>1)</sup>								
Nominal speed of rotation	n <sub>N</sub>	[min <sup>-1</sup> ]	3000	5000	3000	5000	2500	4000
Nominal torque	M <sub>N</sub>	[Nm]	1.34	1.31	2.23	2.06	2.96	2.70
Nominal current	I <sub>N</sub>	[A <sub>rms</sub> ]	1.75	2.76	2.70	4.63	3.47	4.55
Nominal power	P <sub>N</sub>	[kW]	0.42	0.68	0.70	1.08	0.75	1.13
With supply voltage U <sub>n</sub> = 400 V <sub>ac</sub> <sup>1)</sup>								
Nominal speed of rotation	n <sub>N</sub>	[min <sup>-1</sup> ]	5500	-	5500	-	5000	-
Nominal torque	M <sub>N</sub>	[Nm]	1.30	-	2.01	-	2.53	-
Nominal current	I <sub>N</sub>	[A <sub>rms</sub> ]	1.72	-	2.49	-	3.02	-
Nominal power	P <sub>N</sub>	[kW]	0.75	-	1.16	-	1.32	-
With supply voltage U <sub>n</sub> = 480 V <sub>ac</sub> <sup>1)</sup>								
Nominal speed of rotation	n <sub>N</sub>	[min <sup>-1</sup> ]	7000	-	7000	-	6500	-
Nominal torque	M <sub>N</sub>	[Nm]	1.27	-	1.89	-	2.26	-
Nominal current	I <sub>N</sub>	[A <sub>rms</sub> ]	1.70	-	2.36	-	2.74	-
Nominal power	P <sub>N</sub>	[kW]	0.93	-	1.38	-	1.54	-

1) Conditions for performance data: Mounted to steel plate, (2.5 \* flange dimensions)<sup>2</sup> area, 10 mm thickness, centered hole.

2) M<sub>0</sub>=Continuous stall torque at low speed of rotation and 100% duty cycle; at speeds of rotation of < 20 min<sup>-1</sup> the continuous stall torque is reduced to 87%

Motor type			BMH0701	BMH0701	BMH0702	BMH0702	BMH0703	BMH0703
Winding			P	T	P	T	P	T
<b>Technical data - electrical</b>								
Maximum current	$I_{max}$	[A <sub>rms</sub> ]	5.97	9.56	9.68	17.71	12.57	17.84
Continuous stall current	$I_0$	[A <sub>rms</sub> ]	1.78	2.85	2.94	5.38	3.91	5.55
Voltage constant <sup>1)</sup>	$k_{EU-V}$	[V <sub>rms</sub> ]	50.72	31.70	54.08	29.58	55.00	39.29
Torque constant <sup>2)</sup>	$k_t$	[Nm/A]	0.79	0.49	0.84	0.46	0.87	0.61
Winding resistance	$R_{20U-V}$	[Ω]	8.28	3.23	3.84	1.15	2.65	1.32
Winding inductance	$L_{qU-V}$	[mH]	23.40	9.14	12.19	3.64	8.64	4.29
Winding inductance	$L_{dU-V}$	[mH]	24.15	9.43	12.54	3.75	8.91	4.42
<b>Technical data - mechanical</b>								
Maximum permissible speed of rotation	$n_{max}$	[min <sup>-1</sup> ]	8000	8000	8000	8000	8000	8000
Rotor inertia without holding brake	$J_M$	[kgcm <sup>2</sup> ]	0.59	0.59	1.13	1.13	1.67	1.67
Rotor inertia with holding brake	$J_M$	[kgcm <sup>2</sup> ]	0.70	0.70	1.24	1.24	1.78	1.78
Mass without holding brake	$m$	[kg]	1.60	1.60	2.30	2.30	3.00	3.00
Mass with holding brake	$m$	[kg]	2.60	2.60	3.30	3.30	4.00	4.00

1) RMS value at 1000 min<sup>-1</sup> and 20 °C

2) At n = 20 min<sup>-1</sup> and 20 °C

#### 3.2.2 BMH100

Motor type			BMH1001	BMH1001	BMH1002	BMH1002	BMH1003	BMH1003
Winding			P	T	P	T	P	T
<b>Technical data - general</b>								
Continuous stall torque <sup>1)</sup>	M <sub>0</sub> <sup>2)</sup>	[Nm]	3.40	3.40	6.00	6.10	9.00	8.50
Peak torque	M <sub>max</sub>	[Nm]	10.20	10.20	18.00	18.30	27.00	25.50
With supply voltage U <sub>n</sub> = 115 V <sub>ac</sub> <sup>1)</sup>								
Nominal speed of rotation	n <sub>N</sub>	[min <sup>-1</sup> ]	1000	1750	1000	1750	1000	1500
Nominal torque	M <sub>N</sub>	[Nm]	3.30	3.20	5.67	5.75	8.45	7.88
Nominal current	I <sub>N</sub>	[A <sub>rms</sub> ]	3.07	4.85	4.81	8.26	7.30	9.40
Nominal power	P <sub>N</sub>	[kW]	0.35	0.58	0.59	1.05	0.88	1.24
With supply voltage U <sub>n</sub> = 230 V <sub>ac</sub> <sup>1)</sup>								
Nominal speed of rotation	n <sub>N</sub>	[min <sup>-1</sup> ]	2000	4000	2000	3500	2500	3000
Nominal torque	M <sub>N</sub>	[Nm]	3.20	2.90	5.33	5.40	7.63	7.25
Nominal current	I <sub>N</sub>	[A <sub>rms</sub> ]	2.99	4.50	4.58	7.85	6.70	8.80
Nominal power	P <sub>N</sub>	[kW]	0.67	1.20	1.12	1.98	2.00	2.28
With supply voltage U <sub>n</sub> = 400 V <sub>ac</sub> <sup>1)</sup>								
Nominal speed of rotation	n <sub>N</sub>	[min <sup>-1</sup> ]	4000	-	4000	-	4000	-
Nominal torque	M <sub>N</sub>	[Nm]	3.00	-	4.67	-	6.80	-
Nominal current	I <sub>N</sub>	[A <sub>rms</sub> ]	2.83	-	4.10	-	6.07	-
Nominal power	P <sub>N</sub>	[kW]	1.26	-	1.95	-	2.85	-
With supply voltage U <sub>n</sub> = 480 V <sub>ac</sub> <sup>1)</sup>								
Nominal speed of rotation	n <sub>N</sub>	[min <sup>-1</sup> ]	5000	-	5000	-	5000	-
Nominal torque	M <sub>N</sub>	[Nm]	2.90	-	4.20	-	6.25	-
Nominal current	I <sub>N</sub>	[A <sub>rms</sub> ]	2.75	-	3.73	-	5.64	-
Nominal power	P <sub>N</sub>	[kW]	1.52	-	2.27	-	3.27	-

1) Conditions for performance data: Mounted to steel plate 300 \* 300 mm area, 20 mm thickness, centered hole.

2) M<sub>0</sub>=Continuous stall torque at low speed of rotation and 100% duty cycle; at speeds of rotation of < 20 min<sup>-1</sup> the continuous stall torque is reduced to 87%



Motor type			BMH1001	BMH1001	BMH1002	BMH1002	BMH1003	BMH1003
Winding			P	T	P	T	P	T
<b>Technical data - electrical</b>								
Maximum current	$I_{max}$	[A <sub>rms</sub> ]	11.20	18.20	17.50	30.00	26.71	34.70
Continuous stall current	$I_0$	[A <sub>rms</sub> ]	3.15	5.11	5.04	8.65	7.69	10.00
Voltage constant <sup>1)</sup>	$k_{EU-V}$	[V <sub>rms</sub> ]	70.30	43.00	78.00	46.10	77.95	56.00
Torque constant <sup>2)</sup>	$k_t$	[Nm/A]	1.09	0.67	1.19	0.71	1.17	0.85
Winding resistance	$R_{20U-V}$	[Ω]	4.12	1.58	1.97	0.68	1.08	0.61
Winding inductance	$L_{qU-V}$	[mH]	14.90	5.44	8.24	2.84	5.23	2.71
Winding inductance	$L_{dU-V}$	[mH]	13.15	4.78	7.35	2.52	4.62	2.40
<b>Technical data - mechanical</b>								
Maximum permissible speed of rotation	$n_{max}$	[min <sup>-1</sup> ]	6000	6000	6000	6000	6000	6000
Rotor inertia without holding brake	$J_M$	[kgcm <sup>2</sup> ]	3.19	3.19	6.28	6.28	9.37	9.37
Rotor inertia with holding brake	$J_M$	[kgcm <sup>2</sup> ]	3.68	3.68	6.77	6.77	10.30	10.30
Mass without holding brake	$m$	[kg]	3.34	3.34	4.92	4.92	6.50	6.50
Mass with holding brake	$m$	[kg]	4.80	4.80	6.38	6.38	8.15	8.15

1) RMS value at 1000 min<sup>-1</sup> and 20 °C

2) At n = 20 min<sup>-1</sup> and 20 °C

## 3.2.3 BMH140

Motor type			BMH1401	BMH1402	BMH1403
Winding			P	P	P
Technical data - general					
Continuous stall torque <sup>1)</sup>	M <sub>0</sub> <sup>2)</sup>	[Nm]	10.30	18.50	24.00
Peak torque	M <sub>max</sub>	[Nm]	39.90	55.50	75.00
With supply voltage U <sub>n</sub> = 115 V <sub>ac</sub> <sup>1)</sup>					
Nominal speed of rotation	n <sub>N</sub>	[min <sup>-1</sup> ]	1000	1000	750
Nominal torque	M <sub>N</sub>	[Nm]	9.36	16.34	22.17
Nominal current	I <sub>N</sub>	[A <sub>rms</sub> ]	7.82	14.87	18.00
Nominal power	P <sub>N</sub>	[kW]	0.98	1.71	1.78
With supply voltage U <sub>n</sub> = 230 V <sub>ac</sub> <sup>1)</sup>					
Nominal speed of rotation	n <sub>N</sub>	[min <sup>-1</sup> ]	2000	2000	1750
Nominal torque	M <sub>N</sub>	[Nm]	8.50	14.00	19.30
Nominal current	I <sub>N</sub>	[A <sub>rms</sub> ]	7.30	13.13	14.90
Nominal power	P <sub>N</sub>	[kW]	1.78	2.93	3.55
With supply voltage U <sub>n</sub> = 400 V <sub>ac</sub> <sup>1)</sup>					
Nominal speed of rotation	n <sub>N</sub>	[min <sup>-1</sup> ]	3500	3500	3500
Nominal torque	M <sub>N</sub>	[Nm]	7.22	10.17	13.06
Nominal current	I <sub>N</sub>	[A <sub>rms</sub> ]	6.35	9.76	10.42
Nominal power	P <sub>N</sub>	[kW]	2.64	3.73	4.75
With supply voltage U <sub>n</sub> = 480 V <sub>ac</sub> <sup>1)</sup>					
Nominal speed of rotation	n <sub>N</sub>	[min <sup>-1</sup> ]	3500	3500	3500
Nominal torque	M <sub>N</sub>	[Nm]	7.22	10.17	13.06
Nominal current	I <sub>N</sub>	[A <sub>rms</sub> ]	6.35	9.76	10.42
Nominal power	P <sub>N</sub>	[kW]	2.64	3.73	4.75

1) Conditions for performance data: Mounted to steel plate 400 \* 400 mm area, 10 mm thickness, centered hole.

2) M<sub>0</sub>=Continuous stall torque at low speed of rotation and 100% duty cycle; at speeds of rotation of < 20 min<sup>-1</sup> the continuous stall torque is reduced to 87%

Motor type			BMH1401	BMH1402	BMH1403
Winding			P	P	P
<b>Technical data - electrical</b>					
Maximum current	$I_{max}$	[A <sub>rms</sub> ]	29.80	57.42	62.32
Continuous stall current	$I_0$	[A <sub>rms</sub> ]	8.58	16.83	18.00
Voltage constant <sup>1)</sup>	$k_{E\text{U-V}}$	[V <sub>rms</sub> ]	77.41	70.70	85.89
Torque constant <sup>2)</sup>	$k_t$	[Nm/A]	1.20	1.10	1.33
Winding resistance	$R_{20\text{U-V}}$	[Ω]	0.69	0.23	0.22
Winding inductance	$L_{q\text{U-V}}$	[mH]	6.72	2.99	3.00
Winding inductance	$L_{d\text{U-V}}$	[mH]	6.72	2.99	2.80
<b>Technical data - mechanical</b>					
Maximum permissible speed of rotation	$n_{max}$	[min <sup>-1</sup> ]	4000	4000	4000
Rotor inertia without holding brake	$J_M$	[kgcm <sup>2</sup> ]	16.46	32.00	47.54
Rotor inertia with holding brake	$J_M$	[kgcm <sup>2</sup> ]	17.96	33.50	50.27
Mass without holding brake	$m$	[kg]	8.00	12.00	16.00
Mass with holding brake	$m$	[kg]	10.30	14.30	18.53

1) RMS value at 1000 min<sup>-1</sup> and 20 °C

2) At n = 20 min<sup>-1</sup> and 20 °C

### 3 Technical Data

BMH

#### 3.2.4 BMH190

Motor type			BMH1901	BMH1902	BMH1903
Winding			P	P	P
<b>Technical data - general</b>					
Continuous stall torque <sup>1)</sup>	M <sub>0</sub> <sup>2)</sup>	[Nm]	30	48	65
Peak torque	M <sub>max</sub>	[Nm]	90	144	195
With supply voltage U <sub>n</sub> = 400 V <sub>ac</sub> )					
Nominal speed of rotation	n <sub>N</sub>	[min <sup>-1</sup> ]	3000	2000	2000
Nominal torque	M <sub>N</sub>	[Nm]	16.50	29.00	37.00
Nominal current	I <sub>N</sub>	[A <sub>rms</sub> ]	14.00	19.30	21.30
Nominal power	P <sub>N</sub>	[kW]	5.18	6.07	7.75
With supply voltage U <sub>n</sub> = 480 V <sub>ac</sub> )					
Nominal speed of rotation	n <sub>N</sub>	[min <sup>-1</sup> ]	3000	2000	2000
Nominal torque	M <sub>N</sub>	[Nm]	16.50	29.00	37.00
Nominal current	I <sub>N</sub>	[A <sub>rms</sub> ]	14.00	19.30	21.30
Nominal power	P <sub>N</sub>	[kW]	5.18	6.07	7.75

1) Conditions for performance data: Mounted to steel plate 550 x 550 mm area, 30 mm thickness, centered hole.

2) M<sub>0</sub>=Continuous stall torque at low speed of rotation and 100% duty cycle; at speeds of rotation of < 20 min<sup>-1</sup> the continuous stall torque is reduced to 87%

Motor type			BMH1901	BMH1902	BMH1903
Winding			P	P	P
<b>Technical data - electrical</b>					
Maximum current	I <sub>max</sub>	[A <sub>rms</sub> ]	89.6	114	124.5
Continuous stall current	I <sub>0</sub>	[A <sub>rms</sub> ]	23.2	30.8	36.1
Voltage constant <sup>1)</sup>	k <sub>EU-V</sub>	[V <sub>rms</sub> ]	87.6	108.3	129.2
Torque constant <sup>2)</sup>	k <sub>t</sub>	[Nm/A]	1.30	1.56	1.80
Winding resistance	R <sub>20U-V</sub>	[Ω]	0.24	0.15	0.13
Winding inductance	L <sub>qU-V</sub>	[mH]	5.08	3.86	3.62
Winding inductance	L <sub>dU-V</sub>	[mH]	5.23	3.73	3.43
<b>Technical data - mechanical</b>					
Maximum permissible speed of rotation	n <sub>max</sub>	[min <sup>-1</sup> ]	4000	4000	3500
Rotor inertia without holding brake	J <sub>M</sub>	[kgcm <sup>2</sup> ]	67.7	130.1	194.1
Rotor inertia with holding brake	J <sub>M</sub>	[kgcm <sup>2</sup> ]	71.8	144.8	208.8
Mass without holding brake	m	[kg]	19	31	43
Mass with holding brake	m	[kg]	20.5	32.5	44.5

1) RMS value at 1000 min<sup>-1</sup> and 20 °C

2) At n = 20 min<sup>-1</sup> and 20 °C

3.2.5 BMH205

Motor type			BMH2051	BMH2052	BMH2053
Winding			P	P	P
<b>Technical data - general</b>					
Continuous stall torque <sup>1)</sup>	M <sub>0</sub> <sup>2)</sup>	[Nm]	34.4	62.5	88
Peak torque	M <sub>max</sub>	[Nm]	110	220	330
With supply voltage U <sub>n</sub> = 115 V <sub>ac</sub> <sup>1)</sup>					
Nominal speed of rotation	n <sub>N</sub>	[min <sup>-1</sup> ]	750	500	375
Nominal torque	M <sub>N</sub>	[Nm]	31.40	57.90	80.30
Nominal current	I <sub>N</sub>	[A <sub>rms</sub> ]	19.6	22.4	23.6
Nominal power	P <sub>N</sub>	[kW]	2.47	3.03	3.23
With supply voltage U <sub>n</sub> = 230 V <sub>ac</sub> <sup>1)</sup>					
Nominal speed of rotation	n <sub>N</sub>	[min <sup>-1</sup> ]	1500	1000	750
Nominal torque	M <sub>N</sub>	[Nm]	28.20	51.70	75.60
Nominal current	I <sub>N</sub>	[A <sub>rms</sub> ]	17.6	20.0	23.0
Nominal power	P <sub>N</sub>	[kW]	4.43	5.41	5.94
With supply voltage U <sub>n</sub> = 400 V <sub>ac</sub> <sup>1)</sup>					
Nominal speed of rotation	n <sub>N</sub>	[min <sup>-1</sup> ]	3000	2000	1500
Nominal torque	M <sub>N</sub>	[Nm]	21	34	58.7
Nominal current	I <sub>N</sub>	[A <sub>rms</sub> ]	13.1	13.2	18.5
Nominal power	P <sub>N</sub>	[kW]	6.60	7.12	9.22
With supply voltage U <sub>n</sub> = 480 V <sub>ac</sub> <sup>1)</sup>					
Nominal speed of rotation	n <sub>N</sub>	[min <sup>-1</sup> ]	3600	2400	1800
Nominal torque	M <sub>N</sub>	[Nm]	17.90	24.90	50.70
Nominal current	I <sub>N</sub>	[A <sub>rms</sub> ]	11.2	9.7	16.4
Nominal power	P <sub>N</sub>	[kW]	6.75	6.26	9.56

1) Conditions for performance data: Mounted to steel plate, (2.5 \* flange dimensions)<sup>2</sup> area, 10 mm thickness, centered hole.

2) M<sub>0</sub>=Continuous stall torque at low speed of rotation and 100% duty cycle; at speeds of rotation of < 20 min<sup>-1</sup> the continuous stall torque is reduced to 87%

### 3 Technical Data

BMH

Motor type			BMH2051	BMH2052	BMH2053
Winding			P	P	P
<b>Technical data - electrical</b>					
Maximum current	$I_{\max}$	$[A_{\text{rms}}]$	78.1	96.8	107.4
Continuous stall current	$I_0$	$[A_{\text{rms}}]$	21.5	24.2	25.2
Voltage constant <sup>1)</sup>	$k_{\text{EU-V}}$	$[V_{\text{rms}}]$	104	161	218
Torque constant	$k_t$	$[\text{Nm/A}]$	1.6	2.58	3.5
Winding resistance	$R_{20\text{U-V}}$	$[\Omega]$	0.3	0.3	0.32
Winding inductance	$L_{\text{qU-V}}$	$[\text{mH}]$	5.9	5.6	6.9
Winding inductance	$L_{\text{dU-V}}$	$[\text{mH}]$	5.6	5.2	6.4
<b>Technical data - mechanical</b>					
Maximum permissible speed of rotation	$n_{\max}$	$[\text{min}^{-1}]$	3800	3800	3800
Rotor inertia without holding brake	$J_M$	$[\text{kgcm}^2]$	71.4	129	190
Rotor inertia with holding brake	$J_M$	$[\text{kgcm}^2]$	88.4	146	207
Mass without holding brake	$m$	$[\text{kg}]$	33	44	67
Mass with holding brake	$m$	$[\text{kg}]$	37.9	48.9	71.9

1) RMS value at 1000 min<sup>-1</sup> and 20 °C

### 3.3 Dimensions

Dimensions BMH070

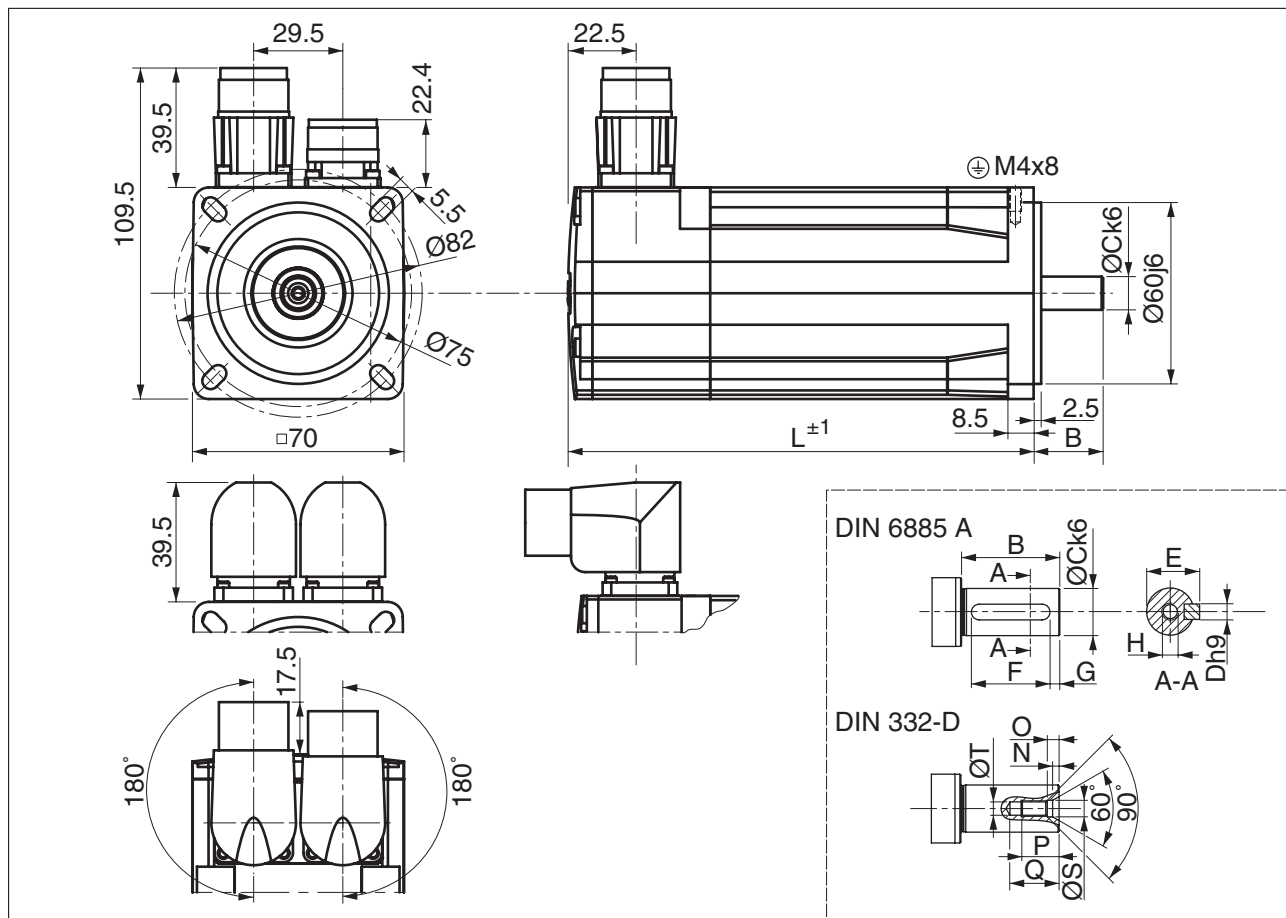

Figure 2: Dimensions BMH070

			BMH0701	BMH0702	BMH0703
L	Length without holding brake	[mm]	122	154	186
L	Length with holding brake	[mm]	161	193	225
B	Shaft length	[mm]	23	23	30
C	Shaft diameter	[mm]	11	11	14
D	Width of parallel key	[mm]	4	4	5
E	Shaft width with parallel key	[mm]	12.5	12.5	16
F	Length of parallel key	[mm]	18	18	20
G	Distance parallel key to shaft end	[mm]	2.5	2.5	5
	Parallel key		DIN 6885-A4x4x18	DIN 6885-A4x4x18	DIN 6885-A4x4x20
H	Female thread of shaft		M4	M4	M5
N		[mm]	2.1	2.1	2.4
O		[mm]	3.2	3.2	4
P		[mm]	10	10	12.5
Q		[mm]	14	14	17
S		[mm]	4.3	4.3	5.3
T		[mm]	3.3	3.3	4.2

019844113749, V1.04, 10.2012

Dimensions BMH100

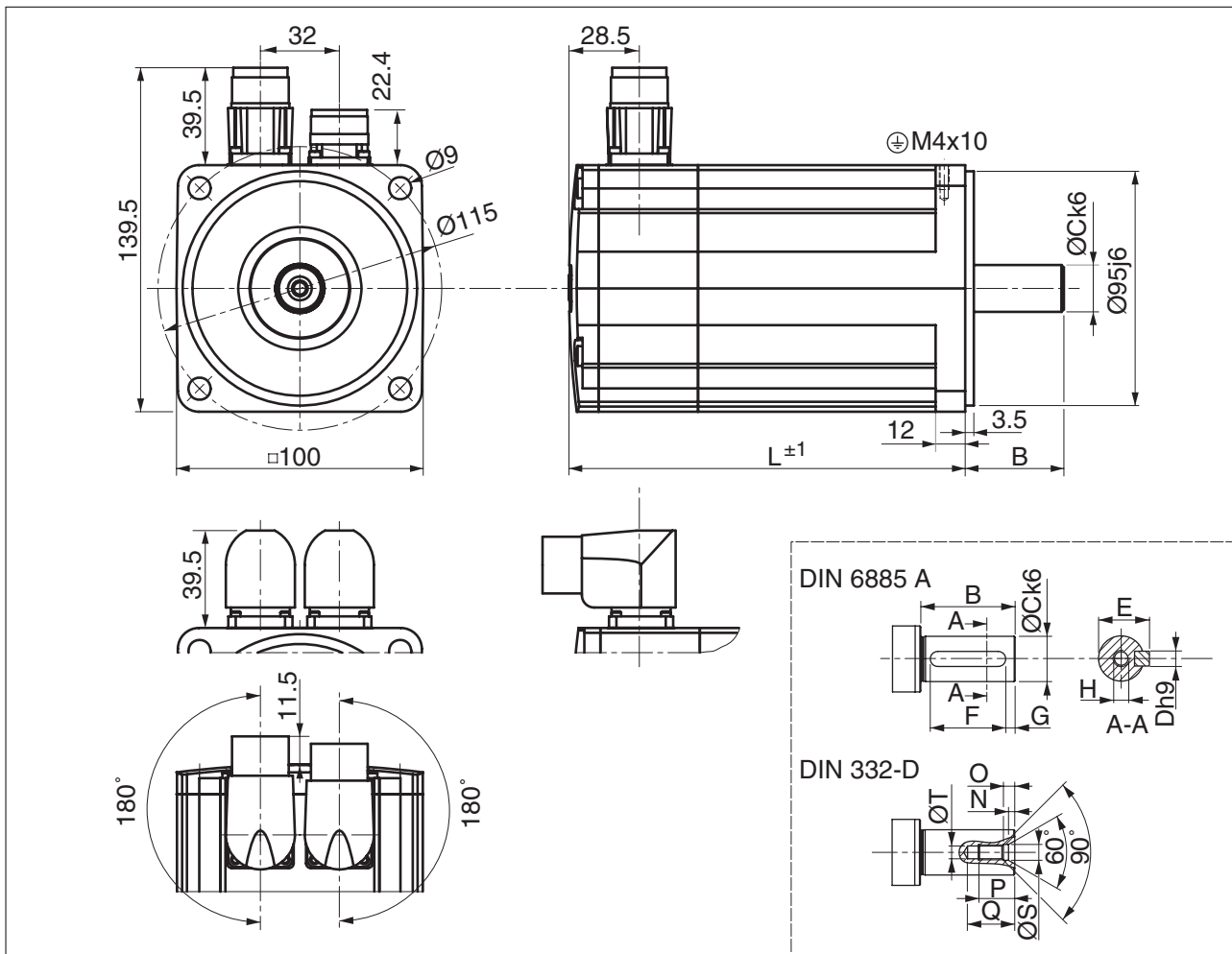

Figure 3: Dimensions BMH100

			<b>BMH1001</b>	<b>BMH1002</b>	<b>BMH1003</b>
<b>L</b>	Length without holding brake	[mm]	128.6	160.6	192.6
<b>L</b>	Length with holding brake	[mm]	170.3	202.3	234.3
<b>B</b>	Shaft length	[mm]	40	40	40
<b>C</b>	Shaft diameter	[mm]	19	19	19
<b>D</b>	Width of parallel key	[mm]	6	6	6
<b>E</b>	Shaft width with parallel key	[mm]	21.5	21.5	21.5
<b>F</b>	Length of parallel key	[mm]	30	30	30
<b>G</b>	Distance parallel key to shaft end	[mm]	5	5	5
	Parallel key		DIN 6885-A6x6x30	DIN 6885-A6x6x30	DIN 6885-A6x6x30
<b>H</b>	Female thread of shaft		M6	M6	M6
<b>N</b>		[mm]	2.8	2.8	2.8
<b>O</b>		[mm]	5	5	5
<b>P</b>		[mm]	16	16	16
<b>Q</b>		[mm]	21	21	21
<b>S</b>		[mm]	6.4	6.4	6.4
<b>T</b>		[mm]	5	5	5



Dimensions BMH140

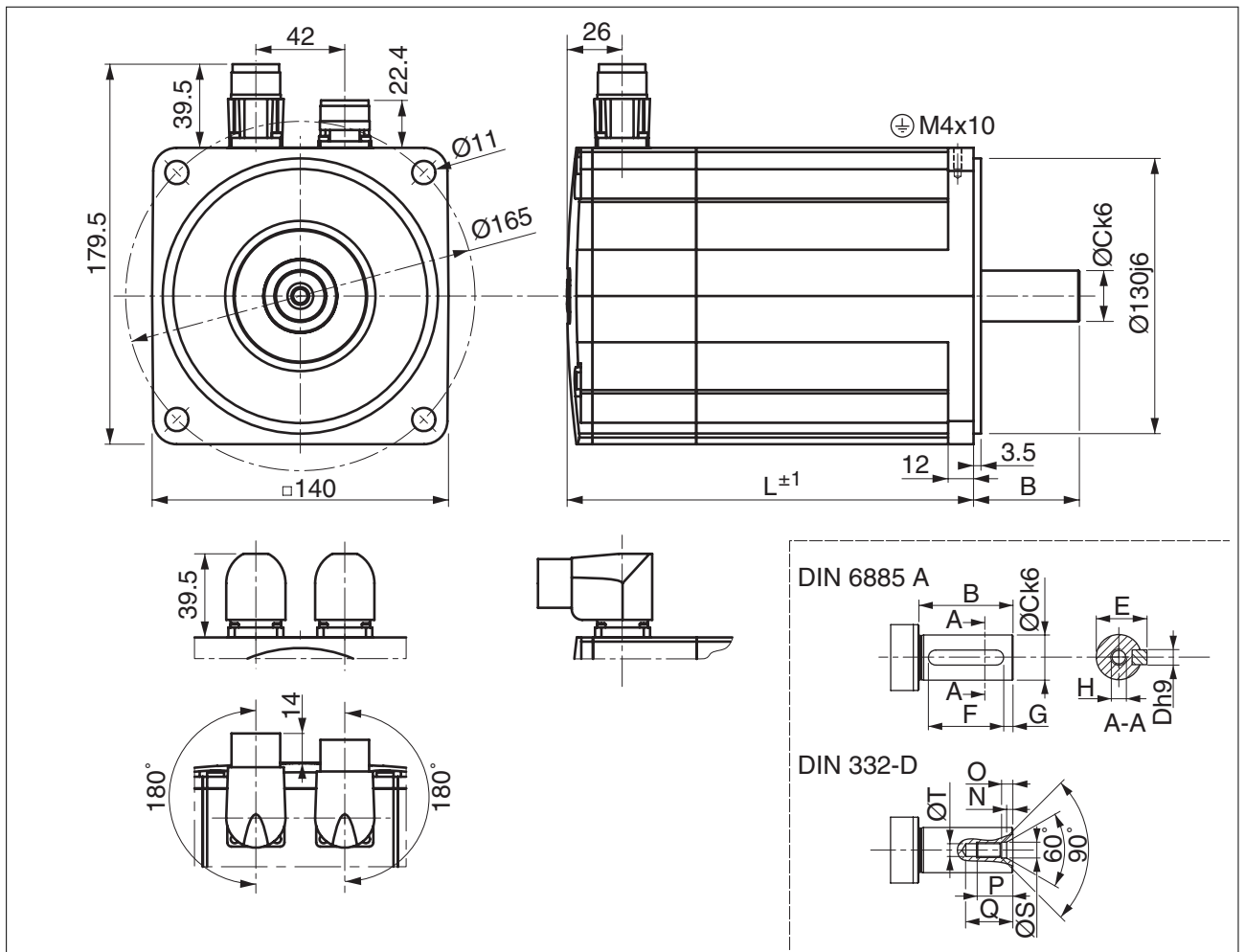

Figure 4: Dimensions BMH140

			BMH1401	BMH1402	BMH1403
L	Length without holding brake	[mm]	152	192	232
L	Length with holding brake	[mm]	187	227	267
B	Shaft length	[mm]	50	50	50
C	Shaft diameter	[mm]	24	24	24
D	Width of parallel key	[mm]	8	8	8
E	Shaft width with parallel key	[mm]	27	27	27
F	Length of parallel key	[mm]	40	40	40
G	Distance parallel key to shaft end	[mm]	5	5	5
	Parallel key		DIN 6885-A8x7x40	DIN 6885-A8x7x40	DIN 6885-A8x7x40
H	Female thread of shaft		M8	M8	M8
N		[mm]	3.3	3.3	3.3
O		[mm]	6	6	6
P		[mm]	19	19	19
Q		[mm]	25	25	25
S		[mm]	8.4	8.4	8.4
T		[mm]	6.8	6.8	6.8

019844113749, V1.04, 10.2012

Dimensions BMH190

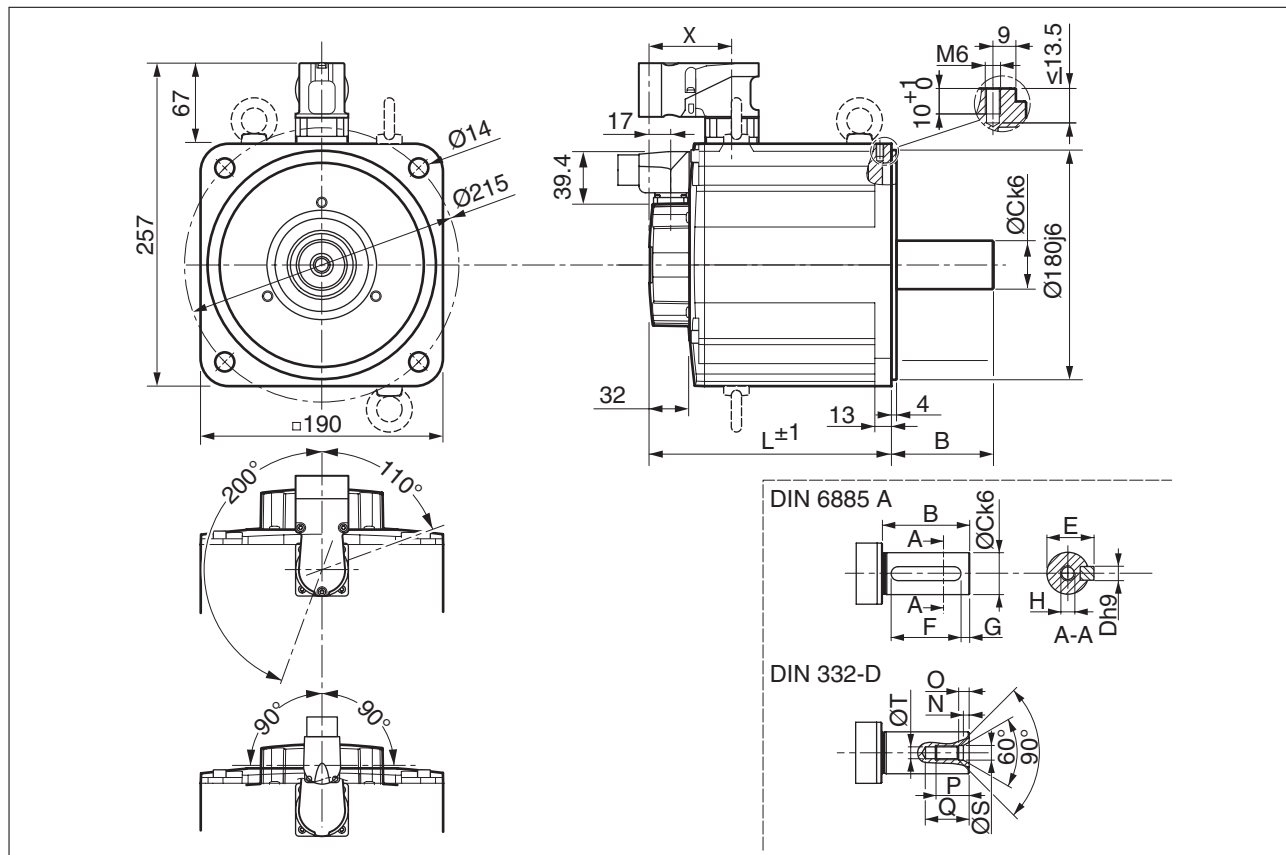

Figure 5: Dimensions BMH190

			BMH1901	BMH1902	BMH1903
L	Length without holding brake	[mm]	190	250	310
L	Length with holding brake	[mm]	248	308	368
X	Length without holding brake	[mm]	65	65	65
X	Length with holding brake	[mm]	123	123	123
B	Shaft length	[mm]	80	80	80
C	Shaft diameter	[mm]	38	38	38
D	Width of parallel key	[mm]	10	10	10
E	Shaft width with parallel key	[mm]	41	41	41
F	Length of parallel key	[mm]	70	70	70
G	Distance parallel key to shaft end	[mm]	5	5	5
	Parallel key		DIN 6885-A10x8x70	DIN 6885-A10x8x70	DIN 6885-A10x8x70
H	Female thread of shaft		M12	M12	M12
N		[mm]	4.4	4.4	4.4
O		[mm]	9.5	9.5	9.5
P		[mm]	28	28	28
Q		[mm]	37	37	37
S		[mm]	13	13	13
T		[mm]	10.2	10.2	10.2

Dimensions BMH205

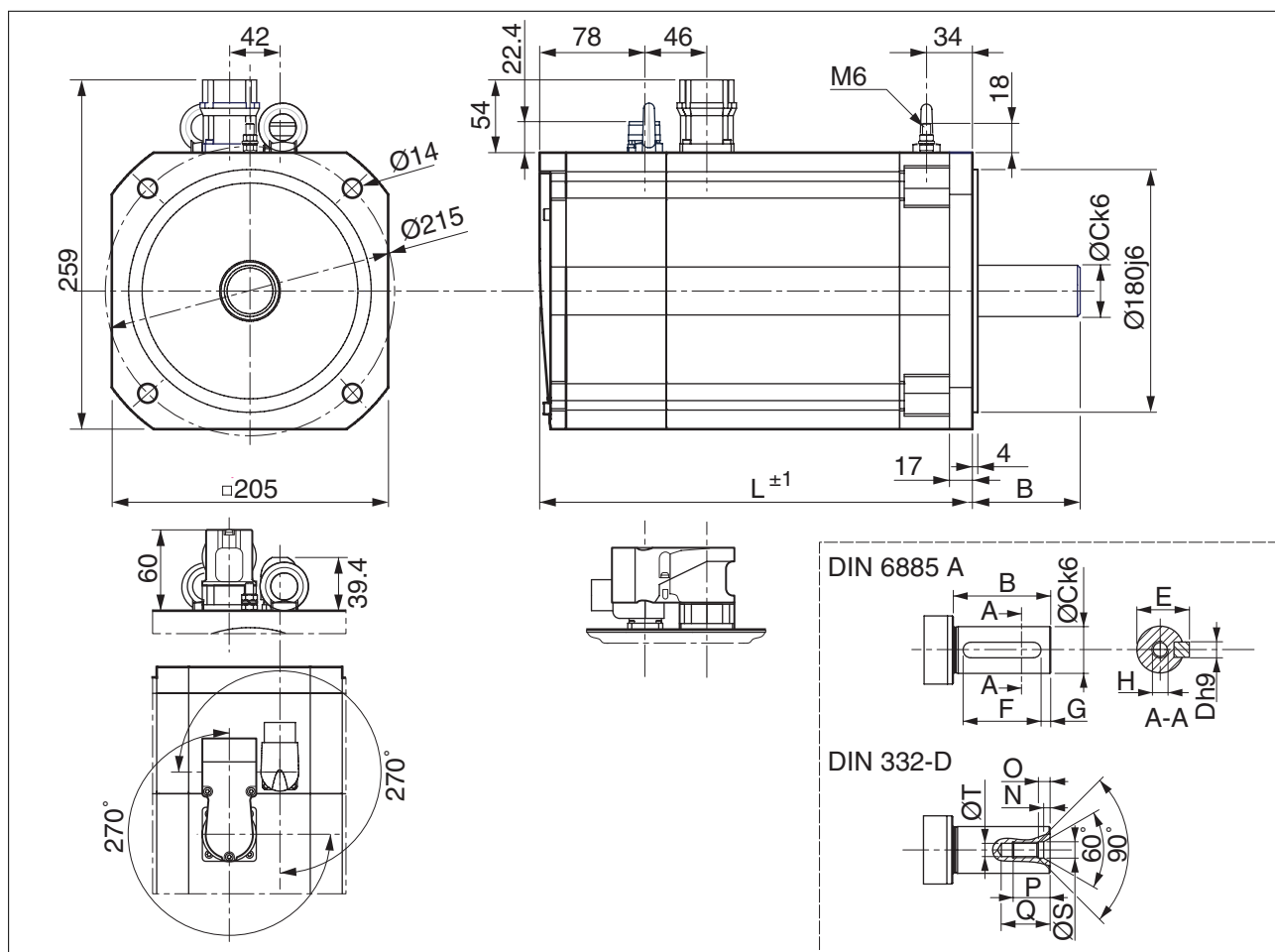

Figure 6: Dimensions BMH205

			<b>BMH2051</b>	<b>BMH2052</b>	<b>BMH2053</b>
<b>L</b>	Length without holding brake	[mm]	321	405	489
<b>L</b>	Length with holding brake	[mm]	370.5	454.5	538.5
<b>B</b>	Shaft length	[mm]	80	80	80
<b>C</b>	Shaft diameter	[mm]	38	38	38
<b>D</b>	Width of parallel key	[mm]	10	10	10
<b>E</b>	Shaft width with parallel key	[mm]	41	41	41
<b>F</b>	Length of parallel key	[mm]	70	70	70
<b>G</b>	Distance parallel key to shaft end	[mm]	5	5	5
	Parallel key		DIN 6885-A10x8x70	DIN 6885-A10x8x70	DIN 6885-A10x8x70
<b>H</b>	Female thread of shaft		M12	M12	M12
<b>N</b>		[mm]	4.4	4.4	4.4
<b>O</b>		[mm]	9.5	9.5	9.5
<b>P</b>		[mm]	28	28	28
<b>Q</b>		[mm]	37	37	37
<b>S</b>		[mm]	13	13	13
<b>T</b>		[mm]	10.2	10.2	10.2

019844113749, V1.04, 10.2012

### 3.4 Shaft-specific data

#### ▲ WARNING

##### UNINTENDED BEHAVIOR CAUSED BY MECHANICAL DAMAGE TO THE MOTOR

If the maximum permissible forces at the shaft are exceeded, this will result in premature wear of the bearing or shaft breakage.

- Do not exceed the maximum permissible axial and radial forces.
- Protect the shaft from impact.
- Do not exceed the maximum permissible axial force when pressing on components.

**Failure to follow these instructions can result in death, serious injury or equipment damage.**

#### 3.4.1 Force for pressing on

*Maximum force during pressing on*

The force applied during pressing on must not exceed the maximum permissible axial force, see chapter "3.4.2 Shaft load". Applying assembly paste (such as Klüberpaste 46 MR 401) to the shaft and the component to be mounted reduces friction and mechanical impact on the surfaces.

If the shaft has a thread, it is recommend to use it to press on the component to be mounted. This way there is no axial force acting on the rolling bearing.

It is also possible to shrink-fit, clamp or glue the component to be mounted.

The following table shows the maximum permissible axial force  $F_A$  at standstill.

BMH...		070	100	140	190	205
	[N]	80	160	300	500	740
	(lb)	(18)	(36)	(65)	(112)	(165)

3.4.2 Shaft load

The following conditions apply:

- The permissible force applied during pressing on must not be exceeded.
- Radial and axial limit loads must not be applied simultaneously
- Nominal bearing service life in operating hours at a probability of failure of 10% ( $L_{10h} = 20000$  hours)
- Mean speed of rotation  $n = 4000 \text{ min}^{-1}$
- Ambient temperature = 40 °C
- Peak torque = Duty types S3 - S8, 10% duty cycle
- Nominal torque = Duty type S1, 100% duty cycle

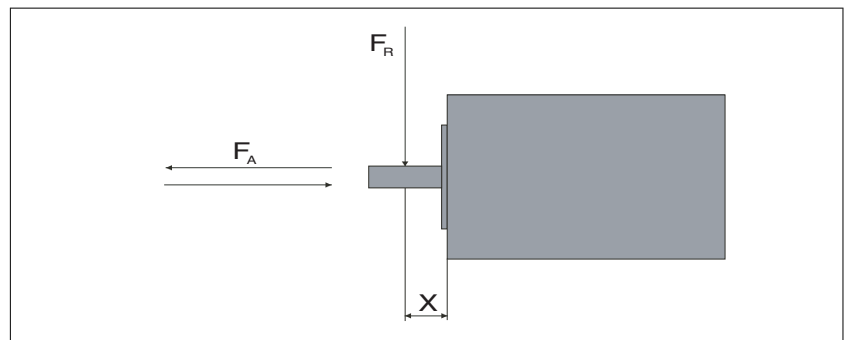

Figure 7: Shaft load

The point of application of the forces depends on the motor size:

Motor version		Values for "X"
BMH0701 and BMH0702	[mm]	11.5
BMH0703	[mm]	15
BMH100	[mm]	20
BMH140	[mm]	25
BMH190	[mm]	40
BMH205	[mm]	40

The following table shows the maximum radial shaft load  $F_R$ .

BMH...		070 1	070 2	070 3	100 1	100 2	100 3	140 1	140 2	140 3
1000 min <sup>-1</sup>	[N]	660	710	730	900	990	1050	1930	2240	2420
2000 min <sup>-1</sup>	[N]	520	560	580	720	790	830	1530	1780	1920
3000 min <sup>-1</sup>	[N]	460	490	510	630	690	730	1340	1550	1670
4000 min <sup>-1</sup>	[N]	410	450	460	570	620	660	-	-	-
5000 min <sup>-1</sup>	[N]	380	410	430	530	580	610	-	-	-
6000 min <sup>-1</sup>	[N]	360	390	400	-	-	-	-	-	-

BMH...		190 1	190 2	190 3	205 1	205 2	205 3
1000 min <sup>-1</sup>	[N]	2900	3200	3300	3730	4200	4500
2000 min <sup>-1</sup>	[N]	2750	3100	3250	2960	3330	3570
3000 min <sup>-1</sup>	[N]	2650	3000	3150	2580	2910	3120
4000 min <sup>-1</sup>	[N]	2600	2950	3100	-	-	-
5000 min <sup>-1</sup>	[N]	-	-	-	-	-	-
6000 min <sup>-1</sup>	[N]	-	-	-	-	-	-

The following table shows the maximum axial shaft load  $F_A$ .

BMH...		070 1	070 2	070 3	100 1	100 2	100 3	140 1	140 2	140 3
1000 min <sup>-1</sup>	[N]	132	142	146	180	198	210	386	448	484
2000 min <sup>-1</sup>	[N]	104	112	116	144	158	166	306	356	384
3000 min <sup>-1</sup>	[N]	92	98	102	126	138	146	268	310	334
4000 min <sup>-1</sup>	[N]	82	90	92	114	124	132	-	-	-
5000 min <sup>-1</sup>	[N]	76	82	86	106	116	122	-	-	-
6000 min <sup>-1</sup>	[N]	72	78	80	-	-	-	-	-	-

BMH...		190 1	190 2	190 3	205 1	205 2	205 3
1000 min <sup>-1</sup>	[N]	580	640	660	746	840	900
2000 min <sup>-1</sup>	[N]	550	620	650	592	666	714
3000 min <sup>-1</sup>	[N]	530	600	630	516	582	624
4000 min <sup>-1</sup>	[N]	520	590	620	-	-	-
5000 min <sup>-1</sup>	[N]	-	-	-	-	-	-
6000 min <sup>-1</sup>	[N]	-	-	-	-	-	-

### 3.5 Options

#### 3.5.1 Holding brake

*Holding brake* The holding brake in the motor has the task of holding the current motor position when the power stage is disabled, even if external forces act (for example, in the case of a vertical axis). The holding brake is not a safety function.

For a description of the controller, see chapter "4.5.3 Holding brake connection".

Motor type		BMH 070	BMH 1001, 2	BMH 1003	BMH 1401	BMH 1402	BMH 1403	BMH 1901	BMH 1902, 3	BMH 205	
Holding torque <sup>1)</sup>	[Nm]	3.0	5.5	9	18	18	23	32	60	80	
Holding brake release time	[ms]	80	70	90	100	100	100	200	220	200	
Holding brake application time	[ms]	10	30	25	50	50	40	60	50	50	
Nominal voltage	[V <sub>dc</sub> ]	24 +5/-15%									24 +6/-10 %
Nominal power (electrical pull-in power)	[W]	7	12	18	18	18	19	22.5	25	40	
Maximum speed of rotation during braking of moving loads		3000									
Maximum number of decelerations during braking of moving loads and 3000 min <sup>-1</sup>		500									
Maximum number of decelerations during braking of moving loads per hour (at even distribution)		20									
Maximum kinetic energy that can be transformed into heat per deceleration during braking of moving loads	[J]	130	150	150	550	550	550	850	850	21000	

1) The holding brake is factory run in. After longer storage periods, parts of the holding brake may corrode. See "Checking/running in the holding brake" in chapter "8 Service, maintenance and disposal".

Table 2: Technical data holding brake

## 3.5.2 Encoder

The standard motor is equipped with a SinCos encoder. The drive can access the electronic nameplate via the Hiperface interface for easy commissioning.

The signals meet the PELV requirements.

*SKS36 Singleturn*

This motor encoder measures an absolute value within one revolution during switching on and continues to count incrementally from this point.

Resolution in increments	Depending on evaluation
Resolution per revolution	128 sin/cos periods
Measuring range absolute	1 revolution
Accuracy of the digital absolute value <sup>1)</sup>	$\pm 0.0889^\circ$
Accuracy of the incremental position	$\pm 0.0222^\circ$
Signal shape	Sinusoidal
Supply voltage	7 ... 12 V <sub>dc</sub>
Maximum supply current	60 mA (without load)
Maximum angular acceleration	200,000 rad/s <sup>2</sup>

1) Depending on the evaluation through the drive, the accuracy may be increased by including the incremental position in the calculation of the absolute value. In this case, the accuracy corresponds to the incremental position.

*SKM36 Multiturn*

This motor encoder measures an absolute value within 4096 revolutions during switching on and continues to count incrementally from this point.

Resolution in increments	Depending on evaluation
Resolution per revolution	128 sin/cos periods
Measuring range absolute	4096 revolutions
Accuracy of the digital absolute value <sup>1)</sup>	$\pm 0.0889^\circ$
Accuracy of the incremental position	$\pm 0.0222^\circ$
Signal shape	Sinusoidal
Supply voltage	7 ... 12 V <sub>dc</sub>
Maximum supply current	60 mA (without load)
Maximum angular acceleration	200,000 rad/s <sup>2</sup>

1) Depending on the evaluation through the drive, the accuracy may be increased by including the incremental position in the calculation of the absolute value. In this case, the accuracy corresponds to the incremental position.



*SEK37 Singleturn* This motor encoder measures an absolute value within one revolution during switching on and continues to count incrementally from this point.

Resolution in increments	Depending on evaluation
Resolution per revolution	16 sin/cos periods
Measuring range absolute	1 revolution
Accuracy of position	± 0.08°
Signal shape	Sinusoidal
Supply voltage	7 ... 12 V <sub>dc</sub>
Maximum supply current	50 mA (without load)

*SEL37 Multiturn* This motor encoder measures an absolute value within 4096 revolutions during switching on and continues to count incrementally from this point.

Resolution in increments	Depending on evaluation
Resolution per revolution	16 sin/cos periods
Measuring range absolute	4096 revolutions
Accuracy of position	± 0.08°
Signal shape	Sinusoidal
Supply voltage	7 ... 12 V <sub>dc</sub>
Maximum supply current	50 mA (without load)

### 3.6 Conditions for UL 1004

*PELV power supply* Use only power supply units that are approved for overvoltage category III.

*Wiring* Use at least 60/75 °C copper conductors.

### 3.7 Certifications

Product certifications:

Certified by	Assigned number	Validity
UL	File E 208613	-

3.8 Declaration of conformity



SCHNEIDER ELECTRIC MOTION DEUTSCHLAND GmbH  
Breslauer Str. 7 D-77933 Lahr

**EC DECLARATION OF CONFORMITY**  
**YEAR 2010**

according to EC Directive on Machinery 2006/42/EC  
 according to EC Directive EMC 2004/108/EC  
 according to EC Directive Low Voltage 2006/95/EC

We hereby declare that the products listed below meet the requirements of the EC Directives indicated with respect to design, construction and version distributed by us. This declaration becomes invalid in the case of any modification to the products not authorized by us.

Designation:	3 Phase servo motor
Type:	BMH070, BMH100, BMH140, BMH190, BMH205
Applied harmonized standards, especially:	EN 60034-1:2004 Thermal class 155 EN 60034-5:2001 Degree of protection according product documentation EN 61800-5-1:2007
Applied national standards and technical specifications, especially:	UL 1004 Product documentation

Company stamp: **Schneider Electric Motion Deutschland GmbH**  
 Postfach 11 80 • D-77901 Lahr  
 Breslauer Str. 7 • D-77933 Lahr

Date/Signature: 30 November 2010 *ppa. Hagemann*

Name/Department: Björn Hagemann/R & D

019844113749, V1.04, 10.2012

## 4 Installation

# 4

### **WARNING**

#### **GREAT MASS OR FALLING PARTS**

The motor can have an unexpectedly great mass.

- Consider the mass of the motor when mounting it. It may be necessary to use a suitable crane.
- Use personal protective equipment (for example, safety shoes and protective gloves).
- Mount the motor in such a way (tightening torque, securing screws) that it cannot come loose even in the case of fast acceleration or continuous vibration.

**Failure to follow these instructions can result in death, serious injury or equipment damage.**

### **WARNING**

#### **STRONG ELECTROMAGNETIC FIELDS**

Motors can generate strong local electrical and magnetic fields. This can cause interference in sensitive devices.

- Keep persons with implants such as pacemakers away from the motor.
- Do not place any sensitive devices close to the motor.

**Failure to follow these instructions can result in death, serious injury or equipment damage.**

### **WARNING**

#### **UNEXPECTED BEHAVIOR CAUSED BY DAMAGE OR FOREIGN OBJECTS**

Damage to the product as well as foreign objects, deposits or humidity can cause unexpected behavior.

- Do not use damaged products.
- Keep foreign objects from getting into the product.
- Verify correct seat of seals and cable entries.

**Failure to follow these instructions can result in death, serious injury or equipment damage.**

**▲ WARNING****HOT SURFACES**

The heat sink at the product may heat up to over 100°C (212°F) during operation.

- Avoid contact with the hot heat sink.
- Do not allow flammable or heat-sensitive parts in the immediate vicinity.
- Consider the measures for heat dissipation described.

**Failure to follow these instructions can result in death or serious injury.**

**▲ CAUTION****DAMAGE CAUSED BY IMPROPER APPLICATION OF FORCES**

If the motor is improperly subjected to loads, it can be damaged or fall down.

- Do not step onto the motor.
- Avoid improper use by means of safeguards at the machine or safety instructions.

**Failure to follow these instructions can result in injury or equipment damage.**

## 4.1 Overview of procedure

Chapter	Page
"4.2 Electromagnetic compatibility, EMC"	45
"4.3 Before mounting"	47
"4.4 Mounting the motor "	52
"4.5.2 Power and encoder connection"	62
"4.5.3 Holding brake connection"	68

- ▶ Finally, verify proper installation.

## 4.2 Electromagnetic compatibility, EMC

<b>⚠ WARNING</b>
<p><b>SIGNAL AND DEVICE INTERFERENCE</b></p> <p>Signal interference can cause unexpected responses of the device.</p> <ul style="list-style-type: none"> <li>• Install the wiring in accordance with the EMC requirements.</li> <li>• Verify compliance with the EMC requirements.</li> </ul> <p><b>Failure to follow these instructions can result in death, serious injury or equipment damage.</b></p>



*EMC requirement: Route motor cable separately*

*Pre-assembled motor cables and encoder cables in many different lengths are available for the drive solutions. Contact your local sales office.*

When planning the wiring, take into account the fact that the motor cable must be routed separately. The motor cable must be separate from the mains cable or the signal wires.

*Motor and encoder cables* Motor and encoder cables are especially critical in terms of EMC. Use only pre-assembled cables or cables that comply with the specifications and implement the EMC measures described below.

EMC measures	Effect
Keep cables as short as possible. Do not install unnecessary cable loops, use short cables from the central grounding point in the control cabinet to the external ground connection.	Reduces capacitive and inductive interference.
Ground the product via the motor flange or with a ground strap to the ground connection at the cover of the connector housing.	Reduces emissions, increases immunity.
Connect large surface areas of cable shields, use cable clamps and ground straps.	Reduces emissions.
Do not install switching elements in motor cables or encoder cables.	Reduces interference.
Route the motor cable at a distance of at least 20 cm from the signal cable or use shielding plates between the motor cable and signal cable.	Reduces mutual interference
Route the motor cable and encoder cable without cutting them. <sup>1)</sup>	Reduces emission.

1) If a cable is cut for the installation, take appropriate measures for uninterrupted shielding (such as a metal housing) at the point of the cut. Connect a large area of the cable shield to the metal housing at both ends of the cut.

*Pre-assembled connection cables (accessories)* Use pre-assembled cables to reduce the risk of wiring errors, see chapter "7 Accessories and spare parts".

Place the female connector of the motor cable onto the male connector and tighten the union nut. Proceed in the same manner with the connection cable of the encoder system. Connect the motor cable and the encoder cable to the drive according to the wiring diagram of the drive.

*Equipotential bonding conductors* Potential differences can result in excessive currents on the cable shields. Use equipotential bonding conductors to reduce currents on the cable shields.

The equipotential bonding conductor must be rated for the maximum current flowing. Practical experience has shown that the following conductor cross sections can be used:

- 16 mm<sup>2</sup> (AWG 4) for equipotential bonding conductors up to a length of 200 m
- 20 mm<sup>2</sup> (AWG 4) for equipotential bonding conductors with a length of more than 200 m

### 4.3 Before mounting

*Checking for damage* Damaged products must neither be installed nor operated.

- ▶ Prior to mounting, check the product for visible damage.

*Checking the holding brake (option)* See chapter "8.3 Maintenance", "Checking/running in the holding brake".

*Cleaning the shaft* The shaft extensions are factory-treated with an anti-corrosive. If output components are glued to the shaft, the anti-corrosive must be removed and the shaft cleaned. If required, use a grease removal agent as specified by the glue manufacturer. If the glue manufacturer does not provide information on grease removal, it is recommended to use acetone.

- ▶ Remove the anti-corrosive. Avoid direct contact of the skin and the sealing material with the anti-corrosive or the cleaning agent.

*Mounting surface for flange* The mounting surface must be stable, clean, deburred and low-vibration.

- ▶ Verify that the system side meets all requirements in terms of dimensions and tolerances.

*Conductor cross sections according to method of installation* The following sections describe the conductor cross sections for two standard methods of installation:

- Method of installation B2:  
Cables in conduits or cable trunking systems
- Method of installation E:  
Cables on open cable trays

Cross section [mm <sup>2</sup> ] <sup>1)</sup>	Current carrying capacity with method of installation E [A] <sup>2)</sup>	Current-carrying capacity with method of installation B2 [A] <sup>2)</sup>
0.75	10.4	8.5
1	12.4	10.1
1.5	16.1	13.1
2.5	22	17.4
4	30	23
6	37	30
10	52	40
16	70	54
25	88	70

1) See chapter "7 Accessories and spare parts" for available cables.  
 2) Values as per IEC 60204-1 for continuous operation, copper conductors and ambient air temperature 40°C; see IEC 60204-1 for additional information.

Note the derating factors for grouping of cables and correction factors for other ambient conditions (IEC 60204-1).

The conductors must have a sufficiently large cross section so that the upstream fuse can trip.

In the case of longer cables, it may be necessary to use a greater conductor cross section to reduce the energy losses.

*Cable specifications* Use pre-assembled cables to reduce the risk of wiring errors. See chapter "7 Accessories and spare parts".

The genuine accessories have the following properties:

<b>Cables with connectors</b>		<b>VW3M5101R•••</b>	<b>VW3M5102R•••</b>	<b>VW3M5103R•••</b>
Cable jacket, insulation		PUR orange (RAL 2003), polypropylene (PP)		
Capacitance	[pF/m]	Approx. 70 (wire/wire) Approx. 110 (wire/shield)		
Number of contacts (shielded)		[(4 x 1.5 mm <sup>2</sup> ) + (2 x 1 mm <sup>2</sup> )]	[(4 x 2.5 mm <sup>2</sup> ) + (2 x 1 mm <sup>2</sup> )]	[(4 x 4 mm <sup>2</sup> ) + (2 x 1 mm <sup>2</sup> )]
Connection version		Motor end 8-pin circular connector M23, other cable end open	Motor end 8-pin circular connector M23, other cable end open	Motor end 8-pin circular connector M40, other cable end open
Cable diameter	[mm]	12 ± 0.2	14 ± 0.3	16.3 ± 0.3
Minimum bend radius	[mm]	90	110	125
Nominal voltage Power wires Signal wires	[V]	600 300		
Maximum orderable length	[m]	75 <sup>1)</sup>		
Permissible temperature range during operation	[°C]	-40 ... 90 (fixed) -20 ... 80 (moving)		
Certifications		UL, cUL, CE, DESINA		

1) Contact your Schneider Electric sales office for longer cables.

<b>Cables without connectors</b>		<b>VW3M5301R••••</b>	<b>VW3M5302R••••</b>	<b>VW3M5303R••••</b>
Cable jacket, insulation		PUR orange (RAL 2003), polypropylene (PP)		
Capacitance	[pF/m]	Approx. 70 (wire/wire) Approx. 110 (wire/shield)		
Number of contacts (shielded)		[(4 x 1.5 mm <sup>2</sup> ) + (2 x 1 mm <sup>2</sup> )]	[(4 x 2.5 mm <sup>2</sup> ) + (2 x 1 mm <sup>2</sup> )]	[(4 x 4 mm <sup>2</sup> ) + (2 x 1 mm <sup>2</sup> )]
Connection version		Both cable ends open	Both cable ends open	Both cable ends open
Cable diameter	[mm]	12 ± 0.2	14 ± 0.3	16.3 ± 0.3
Minimum bend radius	[mm]	90	110	125
Nominal voltage Power wires Signal wires	[V]	600 300		
Maximum orderable length	[m]	100		
Permissible temperature range during operation	[°C]	-40 ... 90 (fixed) -20 ... 80 (moving)		
Certifications		UL, cUL, CE, DESINA		



<b>Cables with connectors</b>		<b>VW3M8102R•••</b>
Cable jacket, insulation		PUR green (RAL 6018), polypropylene (PP)
Capacitance	[pF/m]	Approx. 135 (wire/wire)
Number of contacts (shielded)		[3 x (2 x 0.14 mm <sup>2</sup> ) + (2 x 0.34 mm <sup>2</sup> )]
Connection version		Motor end 12-pin circular connector M23, device end 10-pin connector RJ45
Cable diameter	[mm]	6.8 ± 0.2
Minimum bend radius	[mm]	68
Nominal voltage	[V]	300
Maximum orderable length	[m]	75 <sup>1)</sup>
Permissible temperature range during operation	[°C]	-40 ... 90 (fixed) -20 ... 80 (moving)
Certifications		UL, cUL, CE, DESINA

1) Contact your Schneider Electric sales office for longer cables.

<b>Cables without connectors</b>		<b>VW3M8222R••••</b>
Cable jacket, insulation		PUR green (RAL 6018), polypropylene (PP)
Capacitance	[pF/m]	Approx. 135 (wire/wire)
Number of contacts (shielded)		[3 x (2 x 0.14 mm <sup>2</sup> ) + (2 x 0.34 mm <sup>2</sup> )]
Connection version		Motor end 12-pin circular connector M23, device end 10-pin connector RJ45
Cable diameter	[mm]	6.8 ± 0.2
Minimum bend radius	[mm]	68
Nominal voltage	[V]	300
Maximum orderable length	[m]	100
Permissible temperature range during operation	[°C]	-40 ... 90 (fixed) -20 ... 80 (moving)
Certifications		UL, cUL, CE, DESINA

<b>Cables with connectors</b>		<b>VW3M5105R•••</b>	<b>VW3M5305R•••</b>
Cable jacket, insulation		PUR orange (RAL 2003), polypropylene (PP)	
Capacitance	[pF/m]		
Number of contacts (shielded)		[(4 x 6 mm <sup>2</sup> ) + (2 x 1 mm <sup>2</sup> )]	[(4 x 6 mm <sup>2</sup> ) + (2 x 1 mm <sup>2</sup> )]
Connection version		Motor end 8-pin circular connector M40, other cable end open	Both cable ends open
Cable diameter	[mm]		
Minimum bend radius	[mm]	5 times the cable diameter with permanently installed connection 10 times the cable diameter with flexible installation	
Nominal voltage Power wires Signal wires	[V]	600 300	
Maximum orderable length	[m]	75 <sup>1)</sup>	100 <sup>1)</sup>
Permissible temperature range during operation	[°C]	-40 ... 90 (fixed) -20 ... 80 (moving)	
Certifications		UL, cUL, CE, DESINA	

1) Contact your Schneider Electric sales office for longer cables.

019844113749, V1.04, 10.2012

Cables with connectors		VW3M5104R•••	VW3M5304R•••
Cable jacket, insulation		PUR orange (RAL 2003), polypropylene (PP)	
Capacitance	[pF/m]		
Number of contacts (shielded)		[(4 x 10 mm <sup>2</sup> ) + (2 x 1 mm <sup>2</sup> )]	[(4 x 10 mm <sup>2</sup> ) + (2 x 1 mm <sup>2</sup> )]
Connection version		Motor end 8-pin circular connector M40, other cable end open	Both cable ends open
Cable diameter	[mm]		
Minimum bend radius	[mm]	5 times the cable diameter with permanently installed connection 10 times the cable diameter with flexible installation	
Nominal voltage Power wires Signal wires	[V]	600 300	
Maximum orderable length	[m]	75 <sup>1)</sup>	100 <sup>1)</sup>
Permissible temperature range during operation	[°C]	-40 ... 90 (fixed) -20 ... 80 (moving)	
Certifications		UL, cUL, CE, DESINA	

1) Contact your Schneider Electric sales office for longer cables.

Space for connectors

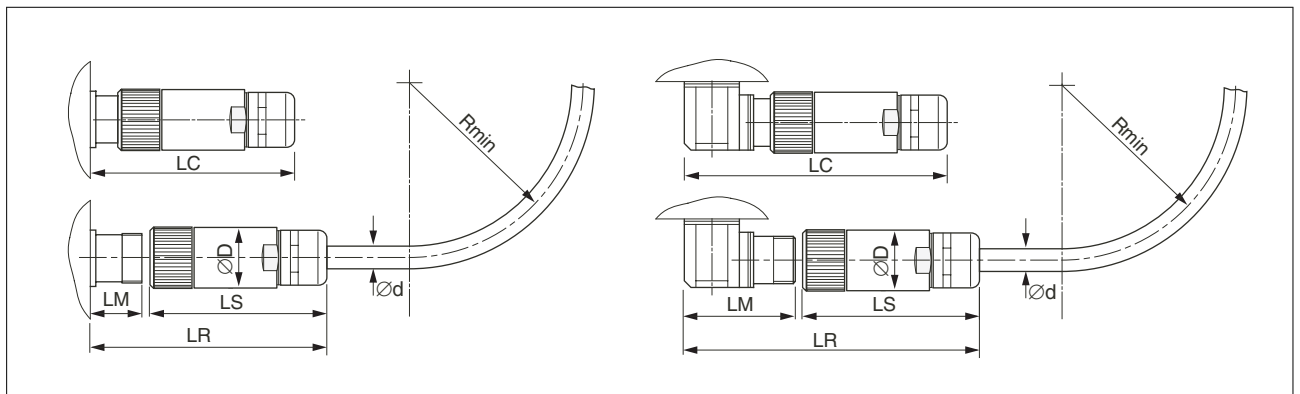

Figure 8: Connector installation space

Dimensions		Motor connectors straight BMH070 ... 140	Motor connectors straight BMH205	Encoder connector straight
D	[mm]	28	46	26
LS	[mm]	76	100	51
LR	[mm]	117	155	76
LC	[mm]	100	145	60
LM	[mm]	40	54	23

Dimensions		Motor connectors angular BMH070 ... 140	Motor connectors angular BMH190 ... 205	Encoder connector angular
D	[mm]	28	46	26
LS	[mm]	76	100	51
LR	[mm]	132	191	105
LC	[mm]	114	170	89
LM	[mm]	55	91	52

Dimensions		Motor cables BMH070 ... 140	Motor cables BMH190 ... 205	Encoder cables
d	[mm]	18	25	18
R <sub>min</sub>	[mm]	90	125	68

## 4.4 Mounting the motor

### WARNING

#### UNEXPECTED MOVEMENT CAUSED BY ELECTROSTATIC DISCHARGE

In rare cases, electrostatic discharge to the shaft may cause incorrect operation of the encoder system and result in unexpected motor movements and damage to the bearing.

- Use conductive components (such as antistatic belts) or other suitable measures to avoid static charge by motion.

**Failure to follow these instructions can result in death, serious injury or equipment damage.**

### WARNING

#### UNEXPECTED MOVEMENT

If the permissible ambient conditions are exceeded, external substances from the environment may penetrate and cause unexpected movement or equipment damage.

- Verify that the ambient conditions are met.
- Do not allow seals to run dry.
- Keep liquids from getting to the shaft bushing (for example in mounting position IM V3).
- Do not expose the shaft sealing rings and cable entries to the direct spray of a pressure washer.

**Failure to follow these instructions can result in death, serious injury or equipment damage.**

### WARNING

#### UNINTENDED BEHAVIOR CAUSED BY MECHANICAL DAMAGE TO THE MOTOR

If the maximum permissible forces at the shaft are exceeded, this will result in premature wear of the bearing, shaft breakage or damage to the encoder.

- Do not exceed the maximum permissible axial and radial forces.
- Protect the shaft from impact.
- Do not exceed the maximum permissible axial force when pressing on components.

**Failure to follow these instructions can result in death, serious injury or equipment damage.**

**⚠ WARNING**

**HOT SURFACES**

The heat sink at the product may heat up to over 100°C (212°F) during operation.

- Avoid contact with the hot heat sink.
- Do not allow flammable or heat-sensitive parts in the immediate vicinity.
- Consider the measures for heat dissipation described.

**Failure to follow these instructions can result in death or serious injury.**

*Mounting position* The following mounting positions are defined and permissible as per IEC 60034-7:

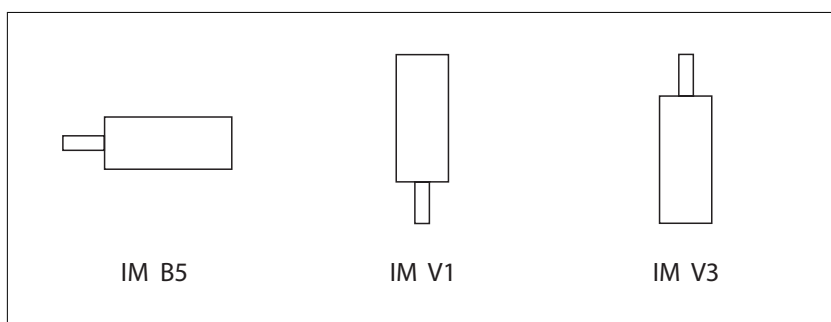

*Mounting situation*

**NOTICE**

**DAMAGE TO THE MOTOR CAUSED BY FORCES ACTING ON THE REAR SIDE OF THE MOTOR**

Motors equipped with eyebolts for transportation purposes are subject to a high risk of damage caused by forces acting at the rear side of the motor, caused by the great mass.

- Do not place the motor on the rear side.
- Protect the rear side of the motor from impact.
- Only lift the motor via the eyebolts, not via the rear side.

**Failure to follow these instructions can result in equipment damage.**

*Special features BMH190*

Figure 9: BMH190 rear side of motor

- (1) Protect the rear side of the motor from application of forces. Consider the mass of the product when mounting the motor. It may be necessary to use suitable lifting gear.

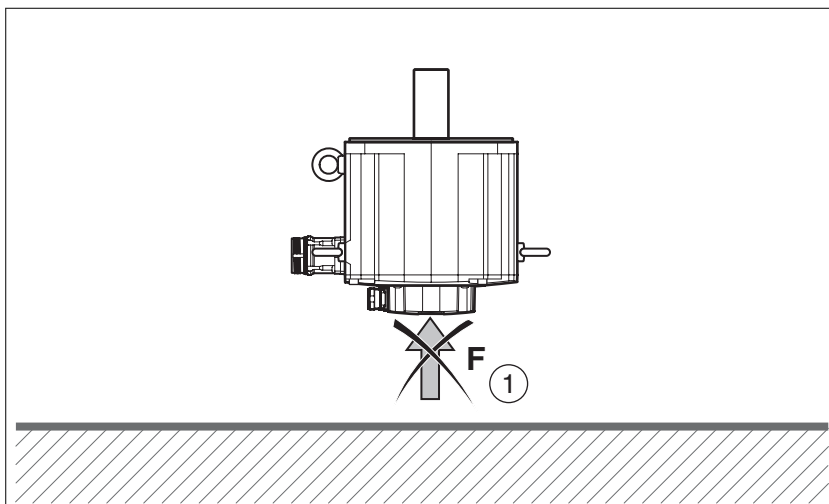
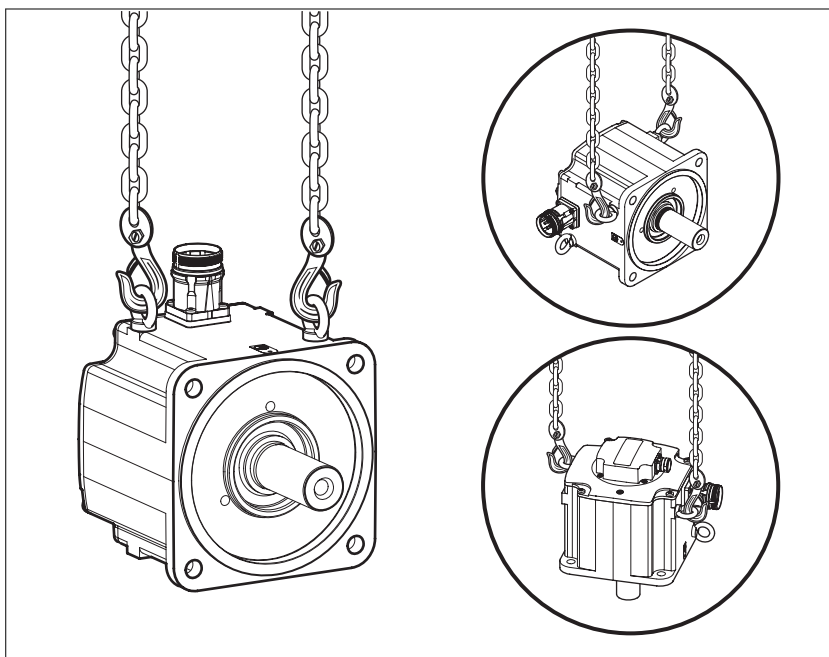

**Mounting** When the motor is mounted to the mounting surface, it must be accurately aligned (axially and radially) and evenly contact the surface. All mounting screws must be tightened with the specified torque. There must be no tension. See chapter "3 Technical Data" for data, dimensions and degrees of protection.

*Mounting output components*

If output components are not properly mounted, the motor may be damaged. Output components such as pulleys, couplings must be mounted with suitable equipment and tools. The maximum axial and radial forces acting on the shaft must not exceed the maximum shaft load values specified, see "3.4.2 Shaft load".

Observe the mounting instructions provided by the manufacturer of the output component. Motor and output component must be accurately aligned both axially and radially. Failure to follow the instructions will cause runout, damage to the rolling bearings and premature wear.

4.4.1 Installation and connection of IP67 kit (accessory)

The IP67 kit is used to connect compressed air to the motor. Degree of protection IP65 is a prerequisite for the use of the IP67 kit. The compressed air generates a permanent overpressure inside the motor. This overpressure inside the motor is used to obtain degree of protection IP67.

Note the special requirements in terms of the compressed air in chapter "3 Technical Data".

*Installation: BMH070, BMH100, BMH140 and BMH205*

When the IP67 kit is installed, the existing cover is replaced by the cover of the IP67 kit. The O-ring is also replaced (shipped with the IP67 kit).

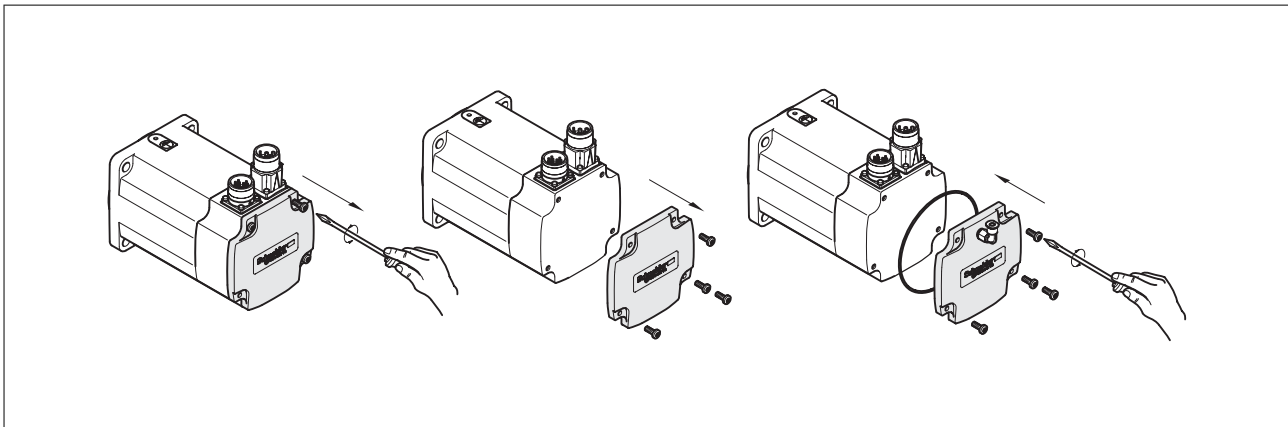

Figure 10: Installation IP67 Kit

- ▶ Loosen the 4 housing screws of the cover.
- ▶ Remove the cover and the O-ring
- ▶ Verify proper seat of the O-ring in the cover of the IP67 kit.

To facilitate mounting of the new O-ring, you may slightly grease the O-ring to hold it in place.

- ▶ Fasten the cover of the IP67 kit with the 4 housing screws. Use the required tightening torque. (Table 1)
- ▶ Verify the tightening torque of the compressed air connection:

Tightening torque compressed air connection	[Nm] (lb·in)	0.6 (5.31)
---	--------------	------------



*Installation: BMH190* For installation, the existing screw plug is replaced by an L-shaped push-in fitting. See 73 for sources of supply of the L-shaped push-in fitting.

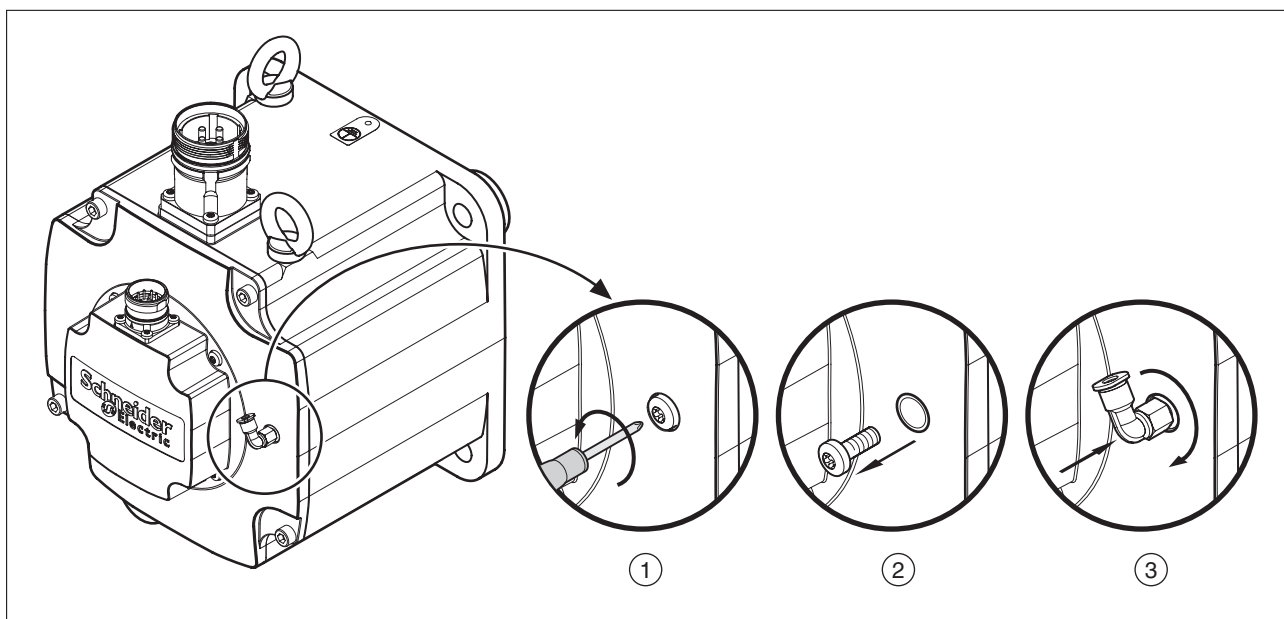

Figure 11: Installation L-shaped push-in fitting BMH190

- ▶ (1) and (2): Remove the screw plug.
- ▶ (3) Screw the L-shaped push-in fitting into the thread.
- ▶ Verify proper seat of the L-shaped push-in fitting.
- ▶ Verify the tightening torque of the L-shaped push-in fitting:

Tightening torque L-shaped push-in fitting	[Nm] (lb·in)	0.6 (5.31)
--	--------------	------------

*Compressed air connection* The compressed air connection of the L-shaped push-in fitting is designed for compressed air hoses made of standard plastic with an outside diameter of 4 mm.

*Compressed air monitoring* It is recommended to use a compressed air monitor.

## 4.5 Electrical installation

### 4.5.1 Connectors and connector assignments

*Connection overview*

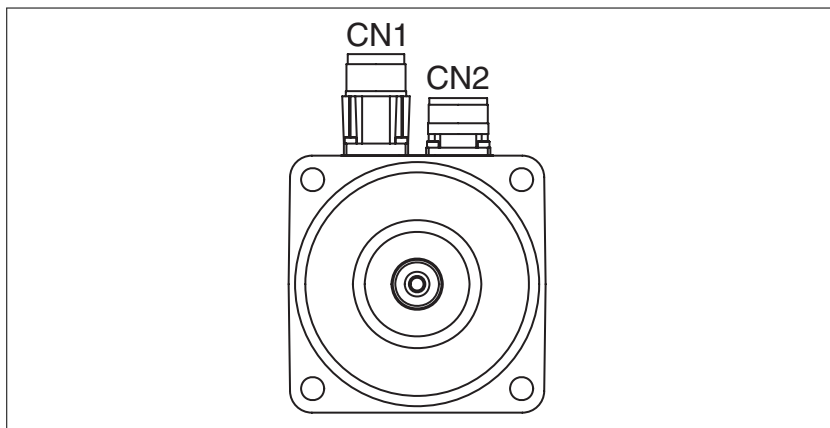

Figure 12: Connection overview

Depending on the motor size, different connector sizes are used for the motor connection CN1. BMH070, BMH100 and BMH140 have an M23 connection. BMH190 and BMH205 have an M40 connection. The encoder connection CN2 is identical irrespective of the motor size.

*CN1 motor connection M23* Motor connector for connection of the motor phases and the holding brake.

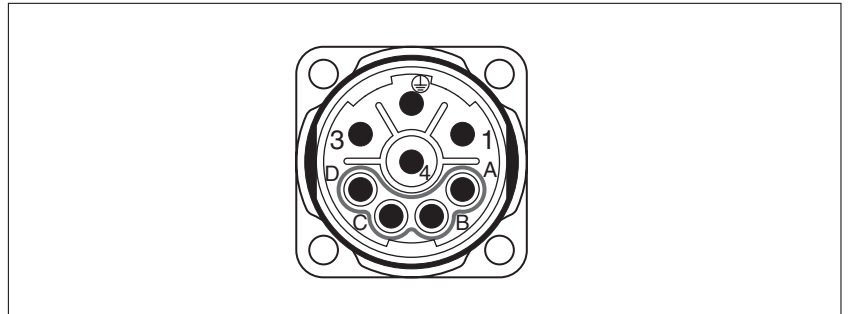

Figure 13: Pin assignment motor connection M23

See chapter "7.2 Connectors" for suitable mating connectors.

The signals of the holding brake meet the PELV requirements.

Pin	Assignment	Meaning
1	U	Motor phase
⊕	PE	Protective ground conductor
3	W	Motor phase W
4	V	Motor phase V
A	BR+	Supply voltage holding brake 24 V <sub>dc</sub>
B	BR-	Reference potential holding brake
C	Reserved	Reserved
D	Reserved	Reserved
	SHLD	Shield (to connector housing)

*CN1 motor connection M40* Motor connector for connection of the motor phases and the holding brake.

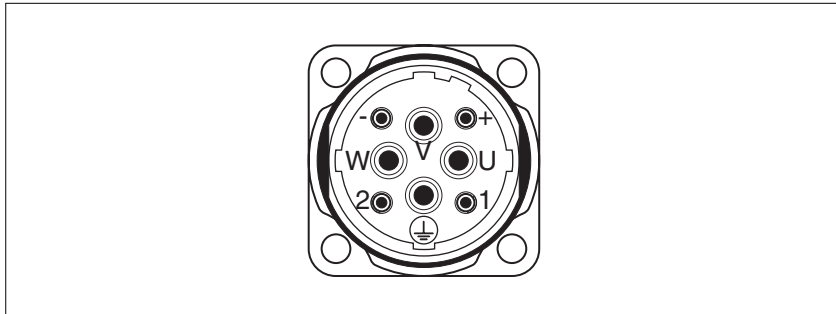

Figure 14: Pin assignment motor connection M40

See chapter "7.2 Connectors" for suitable mating connectors.

The signals of the holding brake meet the PELV requirements.

Pin	Assignment	Meaning
U	U	Motor phase U
⊕	PE	Protective ground conductor
W	W	Motor phase W
V	V	Motor phase V
+	BR+	Supply voltage holding brake 24 V <sub>dc</sub>
-	BR-	Reference potential holding brake
1	Reserved	Reserved
2	Reserved	Reserved
	SHLD	Shield (to connector housing)

*CN2 encoder connection M23*

Encoder connector for connection of the SinCos encoder (singleturn and multiturn)

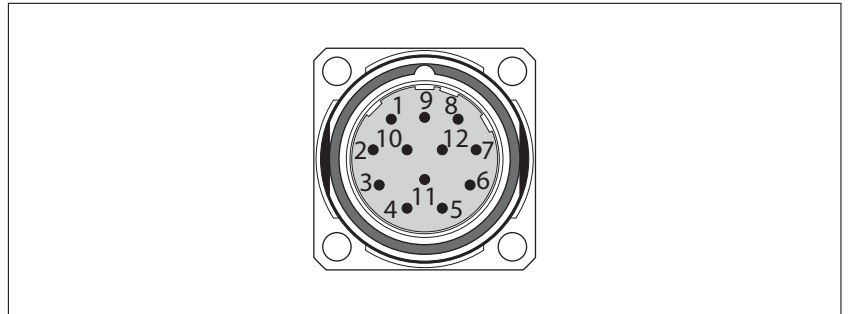

Figure 15: Pin assignment encoder connector

See chapter "7.2 Connectors" for suitable mating connectors.

The signals meet the PELV requirements.

Pin	Signal	Meaning	Pair <sup>1)</sup>
1	Reserved	Reserved	6
2	Reserved	Reserved	5
3	Reserved	Reserved	5
4	REFSIN_OUT	Reference for sine signal, 2.5 V	1
5	REFCOS_OUT	Reference for cosine signal, 2.5V	2
6	DATA	Receive data, transmit data	3
7	$\overline{\text{DATA}}$	Receive data and transmit data, inverted	3
8	SIN_OUT	Sine signal	1
9	COS_OUT	Cosine signal	2
10	ENC+10V	7...12 V supply voltage	6
11	ENC_0V	Reference potential <sup>2)</sup>	4
12	Reserved	Reserved	4
	SHLD	Shield (to connector housing)	

1) Signal pairs must be twisted

2) The ENC\_0V connection of the supply voltage has no connection to the encoder housing.

## 4.5.2 Power and encoder connection

**⚠ ⚠ DANGER****ELECTRIC SHOCK**

High voltages at the motor connection may occur unexpectedly.

- The motor generates voltage when the shaft is rotated. Prior to performing any type of work on the drive system, block the motor shaft to prevent rotation.
- AC voltage can couple voltage to unused conductors in the motor cable. Insulate both ends of unused conductors in the motor cable.
- The system integrator is responsible for compliance with all local and national electrical code requirements as well as all other applicable regulations with respect to grounding of all equipment. Supplement the motor cable grounding conductor with an additional protective ground conductor to the motor housing.

**Failure to follow these instructions will result in death or serious injury.**

**⚠ WARNING****UNEXPECTED MOVEMENT**

Drive systems may perform unexpected movements because of incorrect connection or other errors.

- Operate the motor with approved power stages only. Even if the connectors of a different power stage match, this does not imply compatibility.
- Verify proper wiring.
- Only start the system if there are no persons or obstructions in the hazardous area.
- Perform the first test runs without coupled loads.
- Do not touch the motor shaft or the mounted output components.

**Failure to follow these instructions can result in death, serious injury or equipment damage.**

The motors are not suitable for direct connection to mains power. The motors must be operated with a suitable power stage.

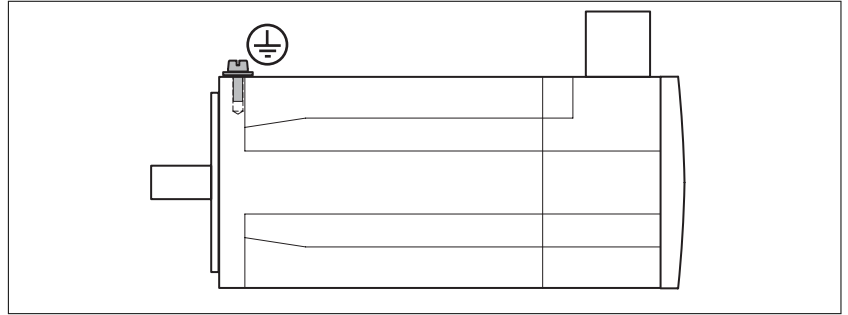
*Protective ground conductor connection*

- ▶ Ground the motor via a grounding screw if grounding via the flange and the protective ground conductor of the motor cable is not sufficient. Use parts with suitable corrosion protection. Note the required tightening torque and the property class of the grounding screw, see Table 1 in chapter 21.

*Assembling cables*

Insulate unused wires individually.

- ▶ Note the EMC requirements for motor cables and encoder cables, page 46.
- ▶ Use equipotential bonding conductors for equipotential bonding.

Follow the procedure and note the dimensions in "Dimensions for crimping and assembling".

Depending on the motor size, different connector sizes are used for the motor connection CN1. BMH070, BMH100 and BMH140 have an M23 connection. BMH190 and BMH205 have an M40 connection. The encoder connection CN2 is identical irrespective of the motor size.

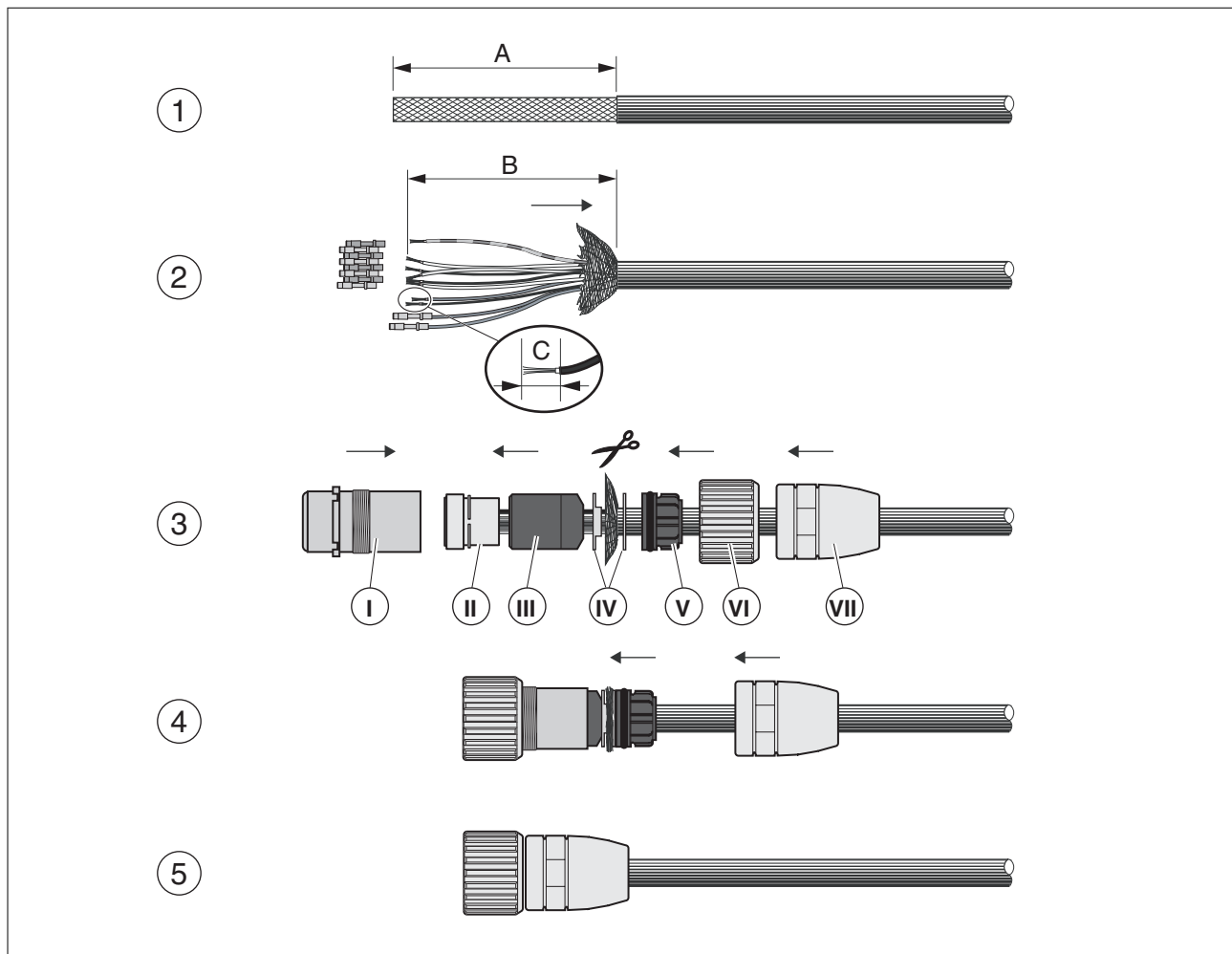

Figure 16: Assembling encoder cables with M23 encoder connector

- ▶ (1) Strip the cable jacket; length as specified (see Table 3).
- ▶ Open the shield braiding and slide it back over the outer cable jacket.
- ▶ Shorten the inner cable jacket.
- ▶ (2) Shorten the wires to the specified length (see Table 3) and crimp them to the connector.

If possible, also connect unused wires. This improves EMC. Wires that are not connected must be insulated at both ends.

- ▶ (3) Push part (IV) and part (III) onto the cable. The cable entry contains rubber seals of various sizes for different cable diameters. Use rubber seals matching the diameter of the cable. Enclose the shield with part (IV). Snap the contacts into part (II). Open part (III) at the side and enclose part (II) as well as the rear part of the contacts with it. Slide part (II) into part (I).
- ▶ (4) Slide part (IV) behind the shield braiding. Slide part (VI) over part (I).
- ▶ Screw part (IV) onto part (I) all the way to the stop.



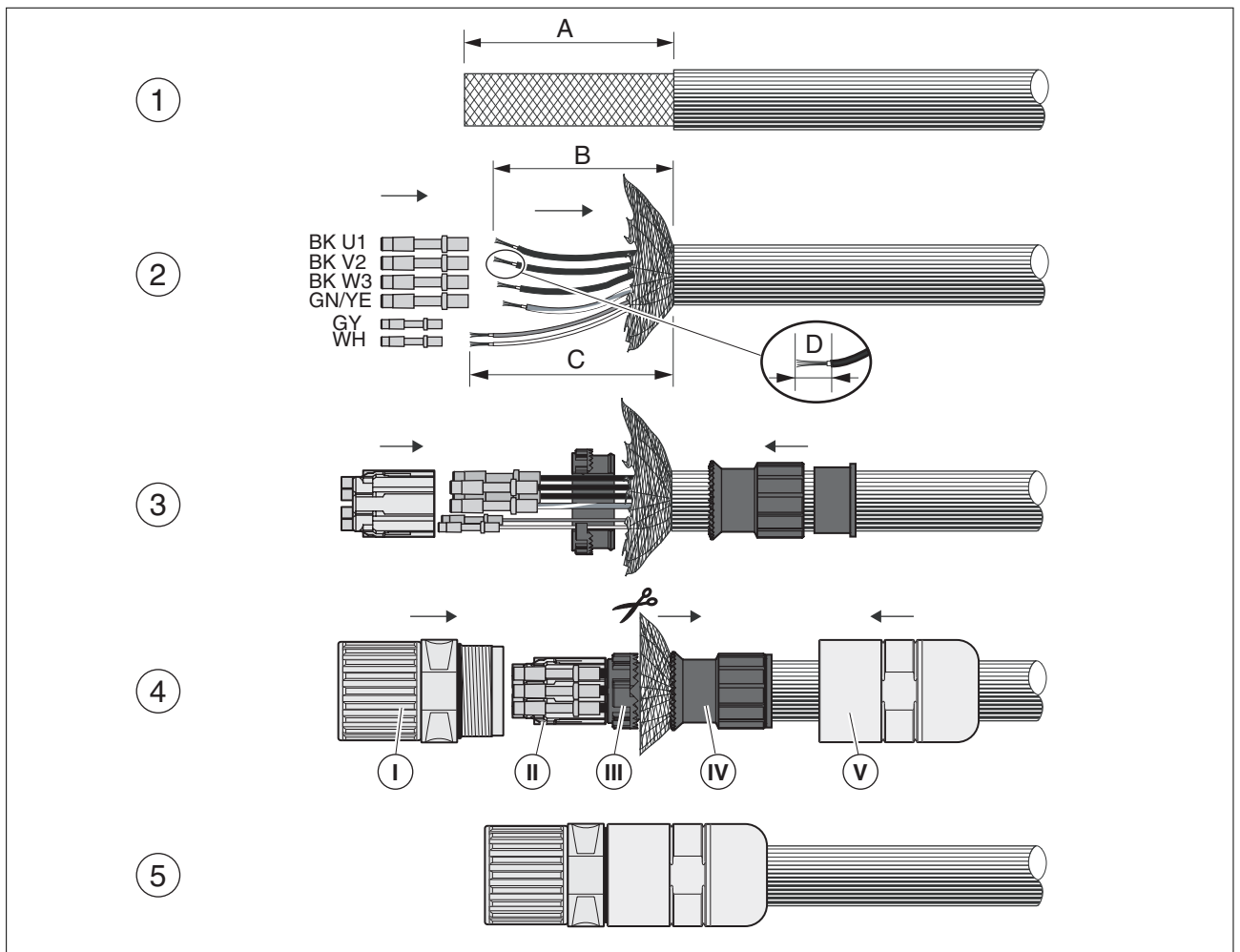

Figure 17: Assembling motor cables with M23 motor connector

- ▶ (1) Strip the cable jacket; length as specified (see Table 3).
  - ▶ Open the shield braiding and slide it back over the outer cable jacket.
  - ▶ Shorten the inner cable jacket.
  - ▶ (2) Shorten the wires to the specified length (see Table 3) and crimp them to the connector.
- If possible, also connect unused wires. This improves EMC. Wires that are not connected must be insulated at both ends.
- ▶ (3) Push part (IV) and part (III) onto the cable. Snap the contacts into part (II). Open the side of part (III) and enclose the wires using this part.
  - ▶ (4) Slide part (III) behind the shield braiding and insert part (II) into part (I). Arrange the shield braiding as shown. Push part (I) and part (III) together and shorten the shield braiding.
  - ▶ Screw part (IV) onto part (I) all the way to the stop.
  - ▶ If your motor is equipped with a holding brake, follow the instructions in chapter "4.5.3 Holding brake connection".

019844113749, V1.04, 10.2012

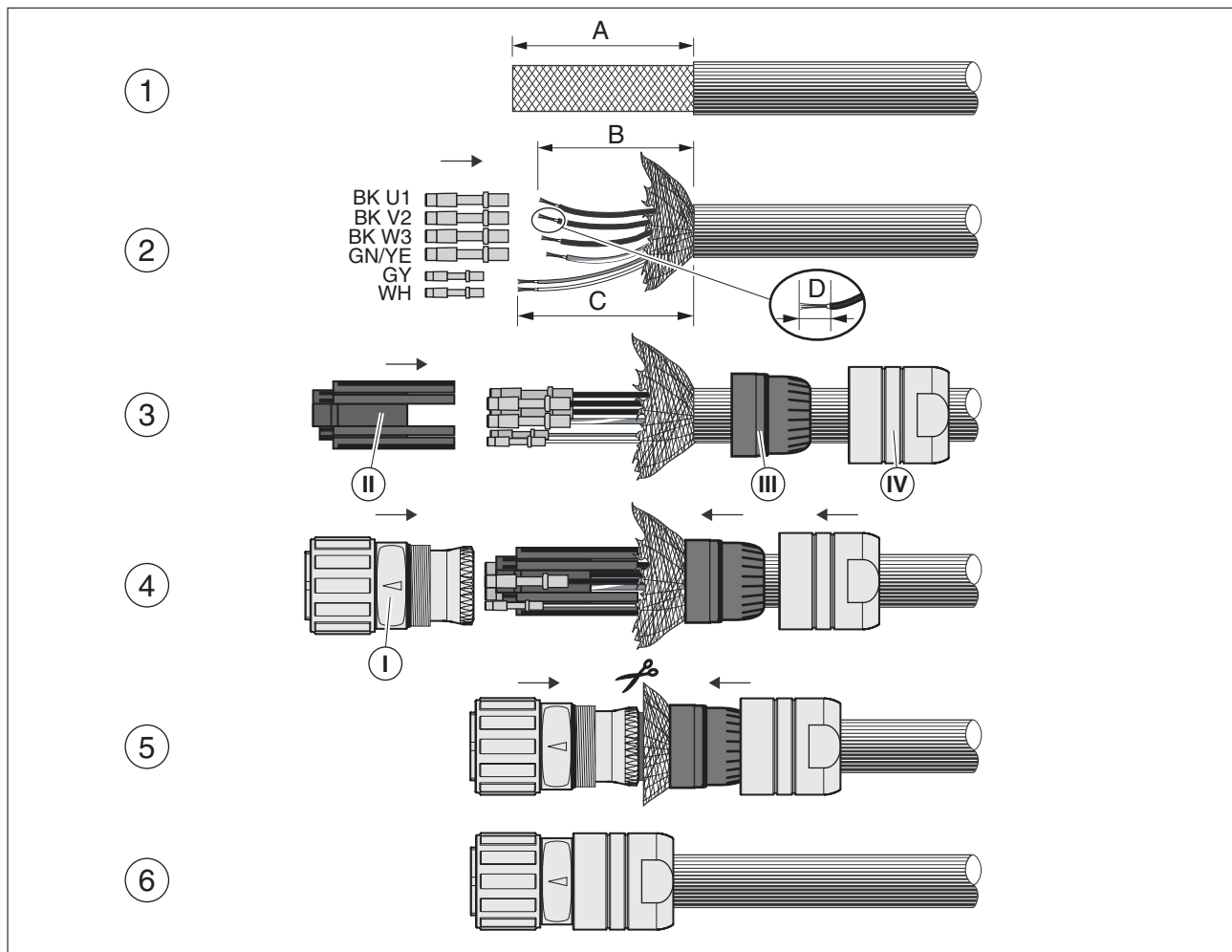

Figure 18: Assembling motor cables with M40 motor connector

- ▶ (1) Strip the cable jacket; length as specified (see Table 3).
- ▶ Open the shield braiding and slide it back over the outer cable jacket.
- ▶ Shorten the inner cable jacket.
- ▶ (2) Shorten the wires to the specified length (see Table 3) and crimp them to the connector.

If possible, also connect unused wires. This improves EMC. Wires that are not connected must be insulated at both ends.

- ▶ (3) Push part (IV) and part (III) onto the cable. Snap the contacts laterally into part (II).
- ▶ (4) Slide part (III) behind the shield braiding and insert part (II) into part (I).
- ▶ (5) Arrange the shield braiding as shown. Push part (I) and part (III) together and shorten the shield braiding.
- ▶ Screw part (IV) onto part (I) all the way to the stop.
- ▶ If your motor is equipped with a holding brake, follow the instructions in chapter "4.5.3 Holding brake connection".

	Signal wires encoder 0.25 mm <sup>2</sup>	Signal wires encoder 0.5 mm <sup>2</sup>	Signal wires holding brake 1 mm <sup>2</sup>	Power wire 1.5 mm <sup>2</sup>	Power wire 2.5 mm <sup>2</sup>	Power wire 4 mm <sup>2</sup>
Stripping length A	28 mm	28 mm	40 mm	40 mm	40 mm	40 mm
Stripping length B	28 mm	28 mm	-	36 mm	36 mm	36 mm
Stripping length C	-	-	40 mm	-	-	-
Stripping length D	4.5 mm	4.5 mm	4.5 mm	8 mm	8 mm	10 mm
Crimping tool	SF-Z0007	SF-Z0007	SF-Z0007	SF-Z0008	SF-Z0008	SF-Z0008
Positioner type	SF-Z2002	SF-Z2002	SF-Z0012	SF-Z0012	SF-Z0012	SF-Z0013
Parameters positioner	Fixed	Fixed	+2	-2	-2	-2
Parameters eccentric	5	6	1	4	6	6

Table 3: Dimensions for crimping and assembling

*Connecting the cables*

**⚠ ⚠ DANGER**

**ELECTRIC SHOCK AND FIRE CAUSED BY INCORRECT INSTALLATION OF THE CABLE**

Incorrect installation of the cable may destroy the insulation. Broken conductors in the cable or improperly connected connectors may be melted by arcs.

- Avoid impermissible movements of the cable.
- Avoid forces or movements of the cable at the cable entry.
- Verify that the connector is properly plugged in and locked.

**Failure to follow these instructions will result in death or serious injury.**

Motor and encoder system connectors must not be disconnected or reconnected as long as voltage is present.

Motor connectors must not be disconnected or reconnected as long as voltage is present.

- ▶ Place the female connector of the motor cable onto the motor connector and tighten the union nut. Proceed in the same manner with the connection cable of the encoder system.

Keep the connection cables from being twisted when tightening the union nut.

- ▶ Connect the motor cable and the encoder cable to the drive according to the wiring diagram of the drive.
- ▶ Ground the shield to a large surface area. See the product manual of the drive for information on connecting the shield.
- ▶ If your motor is equipped with a holding brake, follow the instructions in chapter "4.5.3 Holding brake connection".

## 4.5.3 Holding brake connection

**⚠ WARNING****LOSS OF BRAKING FORCE DUE TO WEAR OR HIGH TEMPERATURE**

Applying the holding brake while the motor is running will cause excessive wear and loss of the braking force.

- Do not use the brake as a service brake.
- Note that a emergency stop may also cause wear.
- Note the maximum number of brake applications and the kinetic energy during braking of moving loads.

**Failure to follow these instructions can result in death, serious injury or equipment damage.**

**⚠ WARNING****UNEXPECTED MOVEMENT**

Releasing the holding brake may cause an unexpected movement in the system, for example if vertical axes are used.

- Take appropriate measures to avoid damage caused by falling or lowering loads.
- Only run the test if there are no persons or obstacles in the hazardous area.

**Failure to follow these instructions can result in death, serious injury or equipment damage.**

**⚠ CAUTION****MISOPERATION OF THE HOLDING BRAKE CAUSED BY INCORRECT VOLTAGE**

If the voltage is incorrect, the holding brake cannot be released which causes wear.

- Note that if the voltage is higher than the specified value, the holding brake may be re-applied.
- Note that if the voltage polarity is incorrect, the holding brake cannot be released.
- Note the voltage drop in the cable according to the conductor cross section.
- Verify that the specified voltage is available at the holding brake connection.

**Failure to follow these instructions can result in injury or equipment damage.**

A motor with a holding brake requires a suitable holding brake controller which releases the brake when the power stage is enabled and locks the motor shaft when the power stage is disabled.

*Cable specifications*

- Minimum wire cross section: 2 \* 1.0 mm<sup>2</sup> (AWG 16)
- Maximum cable length: See product manual of the drive.

## 5 Commissioning

# 5

### **WARNING**

#### **UNEXPECTED MOVEMENT**

Drive systems may perform unexpected movements because of incorrect connection or other errors.

- Operate the motor with approved power stages only. Even if the connectors of a different power stage match, this does not imply compatibility.
- Verify proper wiring.
- Only start the system if there are no persons or obstructions in the hazardous area.
- Perform the first test runs without coupled loads.
- Do not touch the motor shaft or the mounted output components.

**Failure to follow these instructions can result in death, serious injury or equipment damage.**

### **WARNING**

#### **ROTATING PARTS**

Rotating parts may cause injuries and may catch clothing or hair. Loose parts or parts that are out of balance may be catapulted away.

- Verify correct mounting and installation of all rotating parts.
- Use a suitable cover.

**Failure to follow these instructions can result in death, serious injury or equipment damage.**

### **WARNING**

#### **FALLING PARTS**

The motor may move, tip and crash down as a result of the reaction torque.

- Mount the motor securely so it will not break loose during strong acceleration.

**Failure to follow these instructions can result in death, serious injury or equipment damage.**

**▲ WARNING****HOT SURFACES**

The heat sink at the product may heat up to over 100°C (212°F) during operation.

- Avoid contact with the hot heat sink.
- Do not allow flammable or heat-sensitive parts in the immediate vicinity.
- Consider the measures for heat dissipation described.

**Failure to follow these instructions can result in death or serious injury.**

*Verifying correct installation*

The installation must be checked prior to commissioning.

- ▶ Check the mechanical installation.
- ▶ Check the electrical installation.
  - Did you connect all protective ground conductors?
  - Did you properly connect and install all cables and connectors?
  - Did you tighten the cable glands properly?
- ▶ Check the ambient conditions.
  - Does the installation meet the ambient conditions specified?
- ▶ Check the output components.
  - Have the installed output components been balanced and accurately aligned?
- ▶ Check the parallel key at the shaft end of the motor.

If you have a motor with a parallel key groove and parallel key, the parallel key must not be inserted during commissioning without output component or it must be appropriately secured.

- ▶ Verify the function of the holding brake.
  - Is the holding brake able to hold the maximum acting load?
  - Is the holding brake released prior to the start of a movement?



*Observe the information on commissioning in the product manual of the drive.*

## 6 Diagnostics and troubleshooting

# 6

### 6.1 Mechanical problems

Error	Cause	Troubleshooting
Excessive heat	Overload Holding brake not released Heavy pollution	Reduce load Check the holding brake controller Clean the motor
Whistling or knocking noise	Rolling bearings	Contact service
Grinding noise	Rotating output component grinds	Align output component
Radial oscillation	Poor alignment of output component Output component out of balance Shaft bent Resonance with mounting elements	Align output component Balance output component Contact service Check the stiffness of the motor mounting
Axial oscillation	Poor alignment of output component Shocks of the output component Resonance with mounting elements	Align output component Check output component Check the stiffness of the motor mounting

### 6.2 Electrical problems

Error	Cause	Troubleshooting
Motor does not start or starts with problems	Overload Unsuitable settings for the drive Cable damaged	Reduce load Check drive settings Check cables and connections
Excessive heat	Overload	Reduce power
Heat at the connection terminals	Connector loose or not tightened	Tighten connector





## 7 Accessories and spare parts

# 7

### 7.1 IP67 Kit

Degree of protection IP65 is a prerequisite for the use of the IP67 kit (shaft sealing ring).

Description	Order no.
IP67 kit for size 070, cover with compressed air connection, O-ring, 4 screws	VW3M2301
IP67 kit for size 100, cover with compressed air connection, O-ring, 4 screws	VW3M2302
IP67 kit for size 140, cover with compressed air connection, O-ring, 4 screws	VW3M2303
IP67 kit for size 205, cover with compressed air connection, O-ring, 4 screws	VW3M2304
L-shaped push-in fitting, to be bought from Festo	QSML-B-M3-4-20

### 7.2 Connectors

Description	Order no.
Encoder connector (cable end) for motor M23, 5 pcs	VW3M8214
Encoder connector (cable end) for drive RJ45 (10 pins), 5 pcs	VW3M2208
Motor connector (cable end) M23, 1.5 ... 2.5 mm <sup>2</sup> , 5 pcs	VW3M8215
Motor connector (cable end) M40, 4 mm <sup>2</sup> , 5 pcs	VW3M8217
Motor connector (cable end) M40, 6 ... 10 mm <sup>2</sup> , 5 pcs	VW3M8218

**Tools** The tools required for cable assembly can be ordered directly from the manufacturer.

- Crimping tool for encoder connector M23:  
Coninvers SF-Z0007 [www.coninvers.com](http://www.coninvers.com)
- Crimping tool for power connector M23/M40:  
Coninvers SF-Z0008 [www.coninvers.com](http://www.coninvers.com)
- Crimping tools for encoder connector RJ45 10 pins:  
Yamaichi Y-ConTool-11, Y-ConTool-20, Y-ConTool-30  
[www.yamaichi.com](http://www.yamaichi.com)

## 7.3 Motor cables

7.3.1 Motor cables 1.5 mm<sup>2</sup>

Description	Order no.
Motor cable 1.5 m, [(4 x 1.5 mm <sup>2</sup> ) + (2 x 1 mm <sup>2</sup> )] shielded; motor end 8-pin circular connector M23, other cable end open	VW3M5101R15
Motor cable 3 m, [(4 x 1.5 mm <sup>2</sup> ) + (2 x 1 mm <sup>2</sup> )] shielded; motor end 8-pin circular connector M23, other cable end open	VW3M5101R30
Motor cable 5 m, [(4 x 1.5 mm <sup>2</sup> ) + (2 x 1 mm <sup>2</sup> )] shielded; motor end 8-pin circular connector M23, other cable end open	VW3M5101R50
Motor cable 10 m, [(4 x 1.5 mm <sup>2</sup> ) + (2 x 1 mm <sup>2</sup> )] shielded; motor end 8-pin circular connector M23, other cable end open	VW3M5101R100
Motor cable 15 m, [(4 x 1.5 mm <sup>2</sup> ) + (2 x 1 mm <sup>2</sup> )] shielded; motor end 8-pin circular connector M23, other cable end open	VW3M5101R150
Motor cable 20 m, [(4 x 1.5 mm <sup>2</sup> ) + (2 x 1 mm <sup>2</sup> )] shielded; motor end 8-pin circular connector M23, other cable end open	VW3M5101R200
Motor cable 25 m, [(4 x 1.5 mm <sup>2</sup> ) + (2 x 1 mm <sup>2</sup> )] shielded; motor end 8-pin circular connector M23, other cable end open	VW3M5101R250
Motor cable 50 m, [(4 x 1.5 mm <sup>2</sup> ) + (2 x 1 mm <sup>2</sup> )] shielded; motor end 8-pin circular connector M23, other cable end open	VW3M5101R500
Motor cable 75 m, [(4 x 1.5 mm <sup>2</sup> ) + (2 x 1 mm <sup>2</sup> )] shielded; motor end 8-pin circular connector M23, other cable end open	VW3M5101R750
Motor cable 25 m, [(4 x 1.5 mm <sup>2</sup> ) + (2 x 1 mm <sup>2</sup> )] shielded; both cable ends open	VW3M5301R250
Motor cable 50 m, [(4 x 1.5 mm <sup>2</sup> ) + (2 x 1 mm <sup>2</sup> )] shielded; both cable ends open	VW3M5301R500
Motor cable 100 m, [(4 x 1.5 mm <sup>2</sup> ) + (2 x 1 mm <sup>2</sup> )] shielded; both cable ends open	VW3M5301R1000

7.3.2 Motor cables 2.5 mm<sup>2</sup>

Description	Order no.
Motor cable 3 m, [(4 x 2.5 mm <sup>2</sup> ) + (2 x 1 mm <sup>2</sup> )] shielded; motor end 8-pin circular connector M23, other cable end open	VW3M5102R30
Motor cable 5 m, [(4 x 2.5 mm <sup>2</sup> ) + (2 x 1 mm <sup>2</sup> )] shielded; motor end 8-pin circular connector M23, other cable end open	VW3M5102R50
Motor cable 10 m, [(4 x 2.5 mm <sup>2</sup> ) + (2 x 1 mm <sup>2</sup> )] shielded; motor end 8-pin circular connector M23, other cable end open	VW3M5102R100
Motor cable 15 m, [(4 x 2.5 mm <sup>2</sup> ) + (2 x 1 mm <sup>2</sup> )] shielded; motor end 8-pin circular connector M23, other cable end open	VW3M5102R150
Motor cable 20 m, [(4 x 2.5 mm <sup>2</sup> ) + (2 x 1 mm <sup>2</sup> )] shielded; motor end 8-pin circular connector M23, other cable end open	VW3M5102R200
Motor cable 25 m, [(4 x 2.5 mm <sup>2</sup> ) + (2 x 1 mm <sup>2</sup> )] shielded; motor end 8-pin circular connector M23, other cable end open	VW3M5102R250
Motor cable 50 m, [(4 x 2.5 mm <sup>2</sup> ) + (2 x 1 mm <sup>2</sup> )] shielded; motor end 8-pin circular connector M23, other cable end open	VW3M5102R500
Motor cable 75 m, [(4 x 2.5 mm <sup>2</sup> ) + (2 x 1 mm <sup>2</sup> )] shielded; motor end 8-pin circular connector M23, other cable end open	VW3M5102R750
Motor cable 25 m, [(4 x 2.5 mm <sup>2</sup> ) + (2 x 1 mm <sup>2</sup> )] shielded; both cable ends open	VW3M5302R250
Motor cable 50 m, [(4 x 2.5 mm <sup>2</sup> ) + (2 x 1 mm <sup>2</sup> )] shielded; both cable ends open	VW3M5302R500
Motor cable 100 m, [(4 x 2.5 mm <sup>2</sup> ) + (2 x 1 mm <sup>2</sup> )] shielded; both cable ends open	VW3M5302R1000

7.3.3 Motor cables 4 mm<sup>2</sup>

Description	Order no.
Motor cable 3 m, [(4 x 4 mm <sup>2</sup> ) + (2 x 1 mm <sup>2</sup> )] shielded; motor end 8-pin circular connector M40, other cable end open	VW3M5103R30
Motor cable 5 m, [(4 x 4 mm <sup>2</sup> ) + (2 x 1 mm <sup>2</sup> )] shielded; motor end 8-pin circular connector M40, other cable end open	VW3M5103R50
Motor cable 10 m, [(4 x 4 mm <sup>2</sup> ) + (2 x 1 mm <sup>2</sup> )] shielded; motor end 8-pin circular connector M40, other cable end open	VW3M5103R100
Motor cable 15 m, [(4 x 4 mm <sup>2</sup> ) + (2 x 1 mm <sup>2</sup> )] shielded; motor end 8-pin circular connector M40, other cable end open	VW3M5103R150
Motor cable 20 m, [(4 x 4 mm <sup>2</sup> ) + (2 x 1 mm <sup>2</sup> )] shielded; motor end 8-pin circular connector M40, other cable end open	VW3M5103R200
Motor cable 25 m, [(4 x 4 mm <sup>2</sup> ) + (2 x 1 mm <sup>2</sup> )] shielded; motor end 8-pin circular connector M40, other cable end open	VW3M5103R250
Motor cable 50 m, [(4 x 4 mm <sup>2</sup> ) + (2 x 1 mm <sup>2</sup> )] shielded; motor end 8-pin circular connector M40, other cable end open	VW3M5103R500
Motor cable 75 m, [(4 x 4 mm <sup>2</sup> ) + (2 x 1 mm <sup>2</sup> )] shielded; motor end 8-pin circular connector M40, other cable end open	VW3M5103R750
Motor cable 25 m, [(4 x 4 mm <sup>2</sup> ) + (2 x 1 mm <sup>2</sup> )] shielded; both cable ends open	VW3M5303R250
Motor cable 50 m, [(4 x 4 mm <sup>2</sup> ) + (2 x 1 mm <sup>2</sup> )] shielded; both cable ends open	VW3M5303R500
Motor cable 100 m, [(4 x 4 mm <sup>2</sup> ) + (2 x 1 mm <sup>2</sup> )] shielded; both cable ends open	VW3M5303R1000

7.3.4 Motor cables 6 mm<sup>2</sup>

Description	Order no.
Motor cable 3 m, [(4 x 6 mm <sup>2</sup> ) + (2 x 1 mm <sup>2</sup> )] shielded; motor end 8-pin circular connector M40, other cable end open	VW3M5105R30
Motor cable 5 m, [(4 x 6 mm <sup>2</sup> ) + (2 x 1 mm <sup>2</sup> )] shielded; motor end 8-pin circular connector M40, other cable end open	VW3M5105R50
Motor cable 10 m, [(4 x 6 mm <sup>2</sup> ) + (2 x 1 mm <sup>2</sup> )] shielded; motor end 8-pin circular connector M40, other cable end open	VW3M5105R100
Motor cable 15 m, [(4 x 6 mm <sup>2</sup> ) + (2 x 1 mm <sup>2</sup> )] shielded; motor end 8-pin circular connector M40, other cable end open	VW3M5105R150
Motor cable 20 m, [(4 x 6 mm <sup>2</sup> ) + (2 x 1 mm <sup>2</sup> )] shielded; motor end 8-pin circular connector M40, other cable end open	VW3M5105R200
Motor cable 25 m, [(4 x 6 mm <sup>2</sup> ) + (2 x 1 mm <sup>2</sup> )] shielded; motor end 8-pin circular connector M40, other cable end open	VW3M5105R250
Motor cable 50 m, [(4 x 6 mm <sup>2</sup> ) + (2 x 1 mm <sup>2</sup> )] shielded; motor end 8-pin circular connector M40, other cable end open	VW3M5105R500
Motor cable 75 m, [(4 x 6 mm <sup>2</sup> ) + (2 x 1 mm <sup>2</sup> )] shielded; motor end 8-pin circular connector M40, other cable end open	VW3M5105R750
Motor cable 25 m, [(4 x 6 mm <sup>2</sup> ) + (2 x 1 mm <sup>2</sup> )] shielded; both cable ends open	VW3M5305R250
Motor cable 50 m, [(4 x 6 mm <sup>2</sup> ) + (2 x 1 mm <sup>2</sup> )] shielded; both cable ends open	VW3M5305R500
Motor cable 100 m, [(4 x 6 mm <sup>2</sup> ) + (2 x 1 mm <sup>2</sup> )] shielded; both cable ends open	VW3M5305R1000

7.3.5 Motor cables 10 mm<sup>2</sup>

Description	Order no.
Motor cable 3 m, [(4 x 10 mm <sup>2</sup> ) + (2 x 1 mm <sup>2</sup> )] shielded; motor end 8-pin circular connector M40, other cable end open	VW3M5104R30
Motor cable 5 m, [(4 x 10 mm <sup>2</sup> ) + (2 x 1 mm <sup>2</sup> )] shielded; motor end 8-pin circular connector M40, other cable end open	VW3M5104R50
Motor cable 10 m, [(4 x 10 mm <sup>2</sup> ) + (2 x 1 mm <sup>2</sup> )] shielded; motor end 8-pin circular connector M40, other cable end open	VW3M5104R100
Motor cable 15 m, [(4 x 10 mm <sup>2</sup> ) + (2 x 1 mm <sup>2</sup> )] shielded; motor end 8-pin circular connector M40, other cable end open	VW3M5104R150
Motor cable 20 m, [(4 x 10 mm <sup>2</sup> ) + (2 x 1 mm <sup>2</sup> )] shielded; motor end 8-pin circular connector M40, other cable end open	VW3M5104R200
Motor cable 25 m, [(4 x 10 mm <sup>2</sup> ) + (2 x 1 mm <sup>2</sup> )] shielded; motor end 8-pin circular connector M40, other cable end open	VW3M5104R250
Motor cable 50 m, [(4 x 10 mm <sup>2</sup> ) + (2 x 1 mm <sup>2</sup> )] shielded; motor end 8-pin circular connector M40, other cable end open	VW3M5104R500
Motor cable 75 m, [(4 x 10 mm <sup>2</sup> ) + (2 x 1 mm <sup>2</sup> )] shielded; motor end 8-pin circular connector M40, other cable end open	VW3M5104R750
Motor cable 25 m, [(4 x 10 mm <sup>2</sup> ) + (2 x 1 mm <sup>2</sup> )] shielded; both cable ends open	VW3M5304R250
Motor cable 50 m, [(4 x 10 mm <sup>2</sup> ) + (2 x 1 mm <sup>2</sup> )] shielded; both cable ends open	VW3M5304R500
Motor cable 100 m, [(4 x 10 mm <sup>2</sup> ) + (2 x 1 mm <sup>2</sup> )] shielded; both cable ends open	VW3M5304R1000

## 7.4 Encoder cables

Description	Order no.
Encoder cable 1.5 m, [3 x (2 x 0.14 mm <sup>2</sup> ) + (2 x 0.34 mm <sup>2</sup> )] shielded; motor end 12-pin circular connector M23, device end 10-pin connector RJ45	VW3M8102R15
Encoder cable 3 m, [3 x (2 x 0.14 mm <sup>2</sup> ) + (2 x 0.34 mm <sup>2</sup> )] shielded; motor end 12-pin circular connector M23, device end 10-pin connector RJ45	VW3M8102R30
Encoder cable 5 m, [3 x (2 x 0.14 mm <sup>2</sup> ) + (2 x 0.34 mm <sup>2</sup> )] shielded; motor end 12-pin circular connector M23, device end 10-pin connector RJ45	VW3M8102R50
Encoder cable 10 m, [3 x (2 x 0.14 mm <sup>2</sup> ) + (2 x 0.34 mm <sup>2</sup> )] shielded; motor end 12-pin circular connector M23, device end 10-pin connector RJ45	VW3M8102R100
Encoder cable 15 m, [3 x (2 x 0.14 mm <sup>2</sup> ) + (2 x 0.34 mm <sup>2</sup> )] shielded; motor end 12-pin circular connector M23, device end 10-pin connector RJ45	VW3M8102R150
Encoder cable 20 m, [3 x (2 x 0.14 mm <sup>2</sup> ) + (2 x 0.34 mm <sup>2</sup> )] shielded; motor end 12-pin circular connector M23, device end 10-pin connector RJ45	VW3M8102R200
Encoder cable 25 m, [3 x (2 x 0.14 mm <sup>2</sup> ) + (2 x 0.34 mm <sup>2</sup> )] shielded; motor end 12-pin circular connector M23, device end 10-pin connector RJ45	VW3M8102R250
Encoder cable 50 m, [3 x (2 x 0.14 mm <sup>2</sup> ) + (2 x 0.34 mm <sup>2</sup> )] shielded; motor end 12-pin circular connector M23, device end 10-pin connector RJ45	VW3M8102R500
Encoder cable 75 m, [3 x (2 x 0.14 mm <sup>2</sup> ) + (2 x 0.34 mm <sup>2</sup> )] shielded; motor end 12-pin circular connector M23, device end 10-pin connector RJ45	VW3M8102R750
Encoder cable 25 m, [3 x (2 x 0.14 mm <sup>2</sup> ) + (2 x 0.34 mm <sup>2</sup> )] shielded; both cable ends open	VW3M8222R250
Encoder cable 50 m, [3 x (2 x 0.14 mm <sup>2</sup> ) + (2 x 0.34 mm <sup>2</sup> )] shielded; both cable ends open	VW3M8222R500
Encoder cable 100 m, [3 x (2 x 0.14 mm <sup>2</sup> ) + (2 x 0.34 mm <sup>2</sup> )] shielded; both cable ends open	VW3M8222R1000





## 8 Service, maintenance and disposal

# 8

### 8.1 Service address



*If you have any questions please contact your sales office. Your sales office staff will be happy to give you the name of a customer service office in your area.*

<http://www.schneider-electric.com>

### 8.2 Storage

The motors must be transported and stored in a dry, dust-free and vibration-free environment. The ambient conditions and application conditions specified in chapter "3.1 General features" must be met; in case of doubt you must air-condition the storage location.

The storage time is primarily limited by the service life of the lubricants; do not store the product for more than 36 months. It is recommended to periodically operate the drive solution to maintain its operability.

### 8.3 Maintenance

Repairs may only be made by the manufacturer. No warranty or liability is accepted for repairs made by unauthorized persons.

Repairs cannot be made with the device installed.



*Prior to any type of work on the drive system, consult the chapters on Installation and Commissioning for information on the precautions and processes to be observed.*

Include the following points in the maintenance plan of your machine.

#### *Connections and fastening*

- ▶ Check all connection cables and connectors regularly for damage. Replace damaged cables immediately.
- ▶ Check that all output elements are firmly seated.
- ▶ Tighten all mechanical and electrical threaded connections to the specified torque. Check the union nuts at the connection cables.

#### *Lubricating the shaft sealing ring*

In the case of motors with shaft sealing ring, lubricant must be applied to the space between the sealing lip of the shaft sealing ring and the shaft with a suitable non-metallic tool. If the shaft sealing rings are allowed to run dry, the service life of the shaft sealing rings will be significantly reduced.

## Cleaning

**▲ WARNING****UNEXPECTED MOVEMENT**

If the permissible ambient conditions are exceeded, external substances from the environment may penetrate and cause unexpected movement or equipment damage.

- Verify that the ambient conditions are met.
- Do not allow seals to run dry.
- Keep liquids from getting to the shaft bushing (for example in mounting position IM V3).
- Do not expose the shaft sealing rings and cable entries to the direct spray of a pressure washer.

**Failure to follow these instructions can result in death, serious injury or equipment damage.**

Clean dust and dirt off the product at regular intervals. Insufficient heat dissipation to the ambient air may excessively increase the temperature.

Motors are not suitable for cleaning with a pressure washer. The high pressure may force water into the motor.

When using solvents or cleaning agents, verify that the cables, cable entry seals, O-rings and motor paint are not damaged.

## Checking/running in the holding brake



*Occasional braking while the load moves helps to maintain the holding torque of the holding brake. If the brake does not work mechanically for an extended period of time, parts of the holding brake may corrode. Corrosion reduces the holding torque.*

The holding brake is factory run in. If the holding brake does not work mechanically for an extended period of time, parts of the holding brake may corrode. If the holding brake does not have the holding torque indicated in the technical data, it must be run in again.

- The motor is dismounted. The holding brake is applied.
- ▶ Check the holding torque of the holding brake using a torque wrench.
- ▶ Compare the value to the specified holding torque of the holding brake when it was delivered. See chapter "3.5.1 Holding brake".
- ▶ If the holding torque of the holding brake considerably differs from the specified values, manually rotate the motor shaft by 25 rotations in both directions.
- ▶ Repeat the process. Contact your sales office if you cannot restore the original holding torque by repeating the process 3 times.

## Replacing the rolling bearing

The customer must not replace the rolling bearing. The motor will be partially demagnetized by this procedure and lose power.

## 8.4 Changing the motor

### WARNING

#### UNINTENDED MOVEMENT DUE TO CHANGED ABSOLUTE POSITION

If you replace the motor, the absolute position of the encoder changes.

- Reset the absolute position of the encoder after having replaced the motor.

**Failure to follow these instructions can result in death, serious injury or equipment damage.**

- ▶ Switch off all supply voltages. Verify that no voltages are present (safety instructions).
- ▶ Label all connections and uninstall the product.
- ▶ Note the identification number and the serial number shown on the product nameplate for later identification.
- ▶ Install the new product as per chapter "4 Installation".
- ▶ Commission the product as per chapter "5 Commissioning".

## 8.5 Shipping, storage, disposal

Note the ambient conditions in chapter "3.1 General features".

*Shipping* The product must be protected against shocks during transportation. If possible, use the original packaging for shipping.

*Storage* The product may only be stored in spaces where the specified permissible ambient conditions are met.  
Protect the product from dust and dirt.

*Disposal* The product consists of various materials that can be recycled. Dispose of the product in accordance with local regulations.

Visit <http://www.schneider-electric.com> for information and documents on environmental protection as per ISO 14025 such as:

- EoLi (Product End-of-Life Instructions)
- PEP (Product Environmental Profile)



# 9 Glossary



## 9.1 Units and conversion tables

The value in the specified unit (left column) is calculated for the desired unit (top row) with the formula (in the field).

Example: conversion of 5 meters [m] to yards [yd]  
 $5 \text{ m} / 0.9144 = 5.468 \text{ yd}$

### 9.1.1 Length

	in	ft	yd	m	cm	mm
in	-	/ 12	/ 36	* 0.0254	* 2.54	* 25.4
ft	* 12	-	/ 3	* 0.30479	* 30.479	* 304.79
yd	* 36	* 3	-	* 0.9144	* 91.44	* 914.4
m	/ 0.0254	/ 0.30479	/ 0.9144	-	* 100	* 1000
cm	/ 2.54	/ 30.479	/ 91.44	/ 100	-	* 10
mm	/ 25.4	/ 304.79	/ 914.4	/ 1000	/ 10	-

### 9.1.2 Mass

	lb	oz	slug	kg	g
lb	-	* 16	* 0.03108095	* 0.4535924	* 453.5924
oz	/ 16	-	* 1.942559*10 <sup>-3</sup>	* 0.02834952	* 28.34952
slug	/ 0.03108095	/ 1.942559*10 <sup>-3</sup>	-	* 14.5939	* 14593.9
kg	/ 0.45359237	/ 0.02834952	/ 14.5939	-	* 1000
g	/ 453.59237	/ 28.34952	/ 14593.9	/ 1000	-

### 9.1.3 Force

	lb	oz	p	N
lb	-	* 16	* 453.55358	* 4.448222
oz	/ 16	-	* 28.349524	* 0.27801
p	/ 453.55358	/ 28.349524	-	* 9.807*10 <sup>-3</sup>
N	/ 4.448222	/ 0.27801	/ 9.807*10 <sup>-3</sup>	-

### 9.1.4 Power

	HP	W
HP	-	* 746
W	/ 746	-

019844113749, V1.04, 10.2012

## 9.1.5 Rotation

	min <sup>-1</sup> (RPM)	rad/s	deg./s
min <sup>-1</sup> (RPM)	-	* $\pi / 30$	* 6
rad/s	* $30 / \pi$	-	* 57.295
deg./s	/ 6	/ 57.295	-

## 9.1.6 Torque

	lb·in	lb·ft	oz·in	Nm	kp·m	kp·cm	dyne·cm
lb·in	-	/ 12	* 16	* 0.112985	* 0.011521	* 1.1521	* $1.129 \cdot 10^6$
lb·ft	* 12	-	* 192	* 1.355822	* 0.138255	* 13.8255	* $13.558 \cdot 10^6$
oz·in	/ 16	/ 192	-	* $7.0616 \cdot 10^{-3}$	* $720.07 \cdot 10^{-6}$	* $72.007 \cdot 10^{-3}$	* 70615.5
Nm	/ 0.112985	/ 1.355822	/ $7.0616 \cdot 10^{-3}$	-	* 0.101972	* 10.1972	* $10 \cdot 10^6$
kp·m	/ 0.011521	/ 0.138255	/ $720.07 \cdot 10^{-6}$	/ 0.101972	-	* 100	* $98.066 \cdot 10^6$
kp·cm	/ 1.1521	/ 13.8255	/ $72.007 \cdot 10^{-3}$	/ 10.1972	/ 100	-	* $0.9806 \cdot 10^6$
dyne·cm	/ $1.129 \cdot 10^6$	/ $13.558 \cdot 10^6$	/ 70615.5	/ $10 \cdot 10^6$	/ $98.066 \cdot 10^6$	/ $0.9806 \cdot 10^6$	-

## 9.1.7 Moment of inertia

	lb·in <sup>2</sup>	lb·ft <sup>2</sup>	kg·m <sup>2</sup>	kg·cm <sup>2</sup>	kp·cm·s <sup>2</sup>	oz·in <sup>2</sup>
lb·in <sup>2</sup>	-	/ 144	/ 3417.16	/ 0.341716	/ 335.109	* 16
lb·ft <sup>2</sup>	* 144	-	* 0.04214	* 421.4	* 0.429711	* 2304
kg·m <sup>2</sup>	* 3417.16	/ 0.04214	-	* $10 \cdot 10^3$	* 10.1972	* 54674
kg·cm <sup>2</sup>	* 0.341716	/ 421.4	/ $10 \cdot 10^3$	-	/ 980.665	* 5.46
kp·cm·s <sup>2</sup>	* 335.109	/ 0.429711	/ 10.1972	* 980.665	-	* 5361.74
oz·in <sup>2</sup>	/ 16	/ 2304	/ 54674	/ 5.46	/ 5361.74	-

## 9.1.8 Temperature

	°F	°C	K
°F	-	(°F - 32) * 5/9	(°F - 32) * 5/9 + 273.15
°C	°C * 9/5 + 32	-	°C + 273.15
K	(K - 273.15) * 9/5 + 32	K - 273.15	-

## 9.1.9 Conductor cross section

AWG	1	2	3	4	5	6	7	8	9	10	11	12	13
mm <sup>2</sup>	42.4	33.6	26.7	21.2	16.8	13.3	10.5	8.4	6.6	5.3	4.2	3.3	2.6

AWG	14	15	16	17	18	19	20	21	22	23	24	25	26
mm <sup>2</sup>	2.1	1.7	1.3	1.0	0.82	0.65	0.52	0.41	0.33	0.26	0.20	0.16	0.13

## 9.2 Terms and Abbreviations

See chapter "2.5 Standards and terminology" for information on the pertinent standards on which many terms are based. Some terms and abbreviations may have specific meanings with regard to the standards.

<i>Axial forces</i>	Tension or compression forces acting longitudinally on the shaft
<i>Centering collar</i>	Centering device at the motor flange that allows for accurate motor mounting.
<i>DOM</i>	<b>Date of manufacturing:</b> The nameplate of the product shows the date of manufacture in the format DD.MM.YY or in the format DD.MM.YYYY. For example: 31.12.11 corresponds to December 31, 2011 31.12.2011 corresponds to December 31, 2011
<i>Degree of protection</i>	The degree of protection is a standardized specification for electrical equipment that describes the protection against the ingress of foreign objects and water (for example: IP 20).
<i>EMC</i>	Electromagnetic compatibility
<i>Encoder</i>	Sensor that converts a measured distance or angle into an electrical signal. This signal is evaluated by the drive to determine the actual position of a shaft (rotor) or a driving unit.
<i>Error</i>	Discrepancy between a detected (computed, measured or signaled) value or condition and the specified or theoretically correct value or condition.
<i>Error class</i>	Classification of errors into groups. The different error classes allow for specific responses to errors, for example by severity.
<i>Fatal error</i>	In the case of fatal error, the product is no longer able to control the motor so that the power stage must be immediately disabled.
<i>Fault</i>	Fault is a state that can be caused by an error. Further information can be found in the pertinent standards such as IEC 61800-7, ODVA Common Industrial Protocol (CIP).
<i>Fault reset</i>	A function used to restore the drive to an operational state after a detected error is cleared by removing the cause of the error so that the error is no longer active.
<i>Length</i>	In the type code, the length is defined in terms of the number of stacks.
<i>PELV</i>	Protective Extra Low Voltage, low voltage with isolation. For more information: IEC 60364-4-41
<i>Radial forces</i>	Forces that act radially on the shaft
<i>Size</i>	In the type code, the size is defined in terms of the flange size.
<i>Warning</i>	If the term is used outside the context of safety instructions, a warning alerts to a potential problem that was detected by a monitoring function. A warning does not cause a transition of the operating state.





10 Table of figures



1)	Nameplate .....	11
2)	Dimensions BMH070 .....	31
3)	Dimensions BMH100 .....	32
4)	Dimensions BMH140 .....	33
5)	Dimensions BMH190 .....	34
6)	Dimensions BMH205 .....	35
7)	Shaft load .....	37
8)	Connector installation space .....	51
9)	BMH190 rear side of motor .....	54
10)	Installation IP67 Kit .....	56
11)	Installation L-shaped push-in fitting BMH190 .....	57
12)	Connection overview .....	58
13)	Pin assignment motor connection M23 .....	59
14)	Pin assignment motor connection M40 .....	60
15)	Pin assignment encoder connector .....	61
16)	Assembling encoder cables with M23 encoder connector .....	64
17)	Assembling motor cables with M23 motor connector .....	65
18)	Assembling motor cables with M40 motor connector .....	66



11 Index



<b>A</b>		Dimensions .....	31
	Abbreviations .....	87	
	Accessories and spare parts .....	73	
	Approved drives .....	21	
<b>B</b>		<b>E</b>	
	Before you begin	EMC .....	45
	Safety information .....	Motor cable and encoder cable .....	46
		EMC requirement	
		Route motor cable separately .....	45
<b>C</b>		Encoder .....	40
	Cable assembly	Connection .....	62
	Power .....	Multiturn .....	40, 40, 41
	Cable specifications .....	Singleturn .....	41
	Holding brake .....	Encoder cable	
	Certifications .....	EMC requirements .....	46
	Changing the motor .....	Environmental conditions	
	Commissioning .....	Operation .....	20
	Connecting the motor cable .....	Equipotential bonding conductors .....	46
	Connection	<b>F</b>	
	Holding brake .....	Force for pressing on .....	36
	Motor .....	<b>G</b>	
	Power .....	General features .....	19
	Connector	Glossary .....	85
	Installation .....	<b>H</b>	
	Connector assignments .....	Hazard categories .....	14
<b>D</b>		Holding brake .....	39
	Degree of protection .....	Connection .....	68
	Diagnostics .....		
	dimensional drawing, see dimensions		

019844113749, V1.04, 10.2012



**W**

Wiring UL ..... 41