









AC & DC Drives, Servos and Motors













Product and Services Catalogue









April 2005



I	Control Techniques at a glance6	2.3 Commander SX – IP66 solutions32
1.1	Control Techniques – Solutions Through Innovation.....6	Overview.....32
1.2	Drive Centre Engineered Solutions.....8	Feature performance.....33
1.3	Drives, Servos & Controls that Deliver Productivity.....10	Ratings.....33
1.4	Product Matrix Overview.....12	Terminal diagram.....34
2	AC Drives - Simple and Easy14	Terminal description.....35
2.1	Commander SK – Simplicity and Functionality14	Specification.....36
Overview.....14	Overview.....14	Dimensions.....37
Feature performance.....15	Feature performance.....15	Options.....37
Terminal diagram.....16	Terminal diagram.....16	Drive Configuration & Programming.....38
Terminal description.....16	Terminal description.....16	Configuration Tool CTSoft
Specification.....17	Specification.....17	Communication Cable
Dimensions.....17	Dimensions.....17	XPressKey Memory
Options.....18	Options.....18	Operator Interface.....39
Drive Configuration & Programming.....19	Drive Configuration & Programming.....19	6 button version
Configuration Tool	Configuration Tool	Potentiometer version
Programming Communications Cable	Programming Communications Cable	Display only
Cloning & Parameter Storage	Cloning & Parameter Storage	Power Accessories.....39
Operator Interfaces.....20	Operator Interfaces.....20	EMC filter
Remote LED display	Remote LED display	PX-Brake
Remote LCD display	Remote LCD display	Brake Resistors
Power Accessories.....20	Power Accessories.....20	Input/Output.....40
EMC Filters	EMC Filters	Extended I/O
Braking resistors	Braking resistors	Motor Feedback.....41
Gland Cover	Gland Cover	Encoder
Top Cover	Top Cover	Communication.....41
Input/Output.....21	Input/Output.....21	RS485
Extended I/O	Extended I/O	PROFIBUS-DP
Extended I/O with Real Time Clock	Extended I/O with Real Time Clock	INTERBUS
Double Insulated Extended I/O	Double Insulated Extended I/O	DeviceNet
120V I/O	120V I/O	CANopen
Communication.....22	Communication.....22	3 AC Solutions Drives42
MODBUS RTU	MODBUS RTU	3.1 Unidrive SP - The Solutions Platform42
PROFIBUS-DP	PROFIBUS-DP	Overview.....44
DeviceNet	DeviceNet	Feature performance.....45
CANopen	CANopen	Ratings.....47
INTERBUS	INTERBUS	Terminal diagram.....50
Ethernet	Ethernet	Terminal description.....50
Programming Software.....23	Programming Software.....23	Specification.....51
LogicStick ladder & function block program	LogicStick ladder & function block program	Dimensions.....51
LogicStick memory for SyntiLite	LogicStick memory for SyntiLite	Options.....52
2.2 Commander SE – Simple and Easy.....24	2.2 Commander SE – Simple and Easy.....24	Drive Configuration and Programming.....52
Overview.....24	Overview.....24	SmartCard Parameter Cloning
Feature performance.....25	Feature performance.....25	CTSoft Configuration Tool
Ratings.....25	Ratings.....25	Communications Cable
Terminal diagram.....26	Terminal diagram.....26	Operator Interface.....54
Terminal description.....26	Terminal description.....26	LED SM-Keypad
Specification.....27	Specification.....27	LCD SM-Keypad Plus
Dimensions.....27	Dimensions.....27	HMI Range
Options.....28	Options.....28	Power accessories.....54
Drive Configuration & Programming.....28	Drive Configuration & Programming.....28	Braking resistors
Configuration Tool SE Soft	Configuration Tool SE Soft	Internal fitting
Programming Communication Cable	Programming Communication Cable	E Stop duty
QuickKey Cloning Tool	QuickKey Cloning Tool	Cyclic duty
Operator Interface.....29	Operator Interface.....29	EMC filter.....54
Universal Keypad	Universal Keypad	Internal fitting
HMI Operator Interface	HMI Operator Interface	External fitting
Power Accessories.....30	Power Accessories.....30	Motor Feedback.....55
Cable Shield Clamps	Cable Shield Clamps	Universal Encoder Plus
EMC filter	EMC filter	Encoder Plus
Braking resistors	Braking resistors	Resolver Input
Input/Output.....31	Input/Output.....31	Encoder Terminal Connector
Network Communication.....31	Network Communication.....31	Input/Output.....56
RS485 / Modbus RTU	RS485 / Modbus RTU	Extended I/O
PROFIBUS DP	PROFIBUS DP	Extended I/O Plus
INTERBUS	INTERBUS	Extended I/O with Real Time Clock
DeviceNet	DeviceNet	Extended I/O 120V
CANopen	CANopen	Double Insulated Extended I/O

Communication.....	56	5 DC Servo Drives and Motors.....	92
Modbus RTU		5.1 Maestro Range.....	92
PROFIBUS DP		Overview	92
INTERBUS		Feature performance	92
DeviceNet		Specifications.....	92
CTNet		Dimensions	94
CAN		Ratings.....	94
CANopen		Matador motors	95
SLM		Overview	95
SERCOS		Features.....	95
Ethernet		Brake.....	95
Application Co-processor Modules	57	Tacho.....	95
SM-Applications		Dimensions	95
SM-Applications Lite		Drive & Motor Selection.....	96
SM-EZMotion		Speed Torque Curves.....	97
Application Programming Software	58	6 AC Servo Drives and Motors	98
 SyPTLite		6.1 Unidrive  & Unimotor UM/EZ Servo Solutions.....	98
 SyPTPro		Overview	98
PowerTools Pro		Feature performance	101
Solutions Software.....	62	Ratings.....	103
Dual Mode Winder		Terminal diagram.....	104
Flying Shear Control		Terminal description	104
Fan & Pump Duty Assist		Specification.....	105
Unidrive  + Secure Disable.....	65	Dimensions	105
Unidrive  + Secure Disable in Elevators.....	68	Options.....	106
Unidrive  Low Voltage Operation.....	70	Drive Configuration & Programming	106
4 DC Drives.....	74	Cloning & Parameter storage card	
4.1 Mentor II – DC Solutions Drive	74	CTSoft Configuration Tool	
Overview.....	76	Communication cable	
Feature performance	77	Operator Interface	108
Ratings.....	77	LED Keypad	
Terminal diagram.....	78	LCD Keypad	
Terminal description.....	78	HMI Operator Interfaces	
Specification.....	79	Power Accessories.....	108
Dimensions.....	79	Internally fitted brake resistor	
Options/accessories.....	80	E Stop duty resistors	
Configuration Tool (MentorSoft).....	80	Cyclic duty resistors	
Operator Interfaces	81	Internal EMC filter	
Universal Keypad		External EMC filter	
HMI Operator Interfaces		Motor Feedback.....	109
Input/Output.....	81	Universal Encoder	
Remote I/O		Second Encoder	
Network I/O		Resolver	
Field Regulation		Encoder Terminal Connector	
Communication.....	82	Input/Output.....	110
Modbus RTU		Extended I/O	
PROFIBUS DP		Extended I/O with Real Time Clock	
Interbus		Extended I/O Plus	
CTNet		Double Insulated Extended I/O	
DeviceNet		120V I/O	
Modbus +		Remote I/O	
Application Co-processor Modules	83	Communication.....	110
MD29 & MD29AN		Modbus RTU	
Applications Programming Software	84	PROFIBUS-DP	
 SyPTPro		INTERBUS	
12/24 Pulse Configuration	86	DeviceNet	
4.2 Small DC Drives	91	CTNet	
Puma.....	91	CAN Interface	
Cheetah	91	CANopen	
Lynx	91	Ethernet	
4Q2	91	SERCOS	
		SLM Interface	

Application Co-processor Modules.....	111	Terminal diagram.....	158
SM-Applications		Terminal description.....	158
SM-Applications Lite		Specification.....	158
SM-EZ Motion		Dimensions.....	159
Application Programming Software.....	112	MM55 motor.....	159
 SyPT Lite		Overview.....	159
 SyPT Pro		Specification.....	159
PowerTools Pro		Dimensions.....	159
Solutions Software.....	116	MiniAx & MM55 motor selection.....	160
Flying Shear Control		MiniAx & MM55 speed torque curves.....	161
Unimotor EZ/UM.....	117	Power & Signal Cable selection.....	162
Overview.....	117		
Nameplate detail.....	117	7 Motion Control.....	164
Dimensions.....	118	Overview.....	164
Specifications.....	120	7.1 Decentralised Motion Control.....	165
Unidrive  & Unimotor UM Selection (400V).....	122	Overview.....	165
Unidrive  & Unimotor UM Speed Torque Curves (400V).....	123	Motion Made Easy with Unidrive 	166
Unidrive  & Unimotor EZ Selection (200V).....	124	using Power Tools Pro.....	166
Unidrive  & Unimotor EZ Speed Torque Curves (200V).....	125	Overview	
Power & Signal Cable selection.....	126	Savings	
6.2 Epsilon & Unimotor EZ.....	130	Performance	
Overview.....	130	Unidrive 	
Epsilon EB base drive operation.....	131	Application co-processor modules	
Pulse mode.....	132	SM-EZMotion	
Velocity mode.....	132	Application programming software	
Torque mode.....	132	PowerTools Pro	
Flexible I/O functionality.....	132	Unidrive SP	
Epsilon Ei compact indexing drive.....	133	SM-EZMotion	
Indexing.....	133	Motion with Unidrive  and 	170
Jogging.....	134	Overview	
Homing.....	134	Savings	
Flexible I/O functionality.....	134	Performance	
Epsilon Ei-Dn DeviceNet.....	135	Unidrive SP	
Dimensions.....	137	Application co-processor modules	
Specifications.....	137	SM-Applications Lite	
Ratings.....	137	SM-Applications	
Unimotor EZ.....	138	Application programming software	
Overview.....	138	 SyPT Lite	
Specifications.....	138	 SyPT Pro	
Motor Dimensions.....	139	PLCopen Motion Programming	
Ratings.....	139	CTSync	
Epsilon & Unimotor motor selection.....	140	Motion Functionality Summary	
Epsilon & Unimotor speed torque curves.....	140	7.2 Centralised Motion Control.....	176
Power & Signal Cable selection.....	141	Overview.....	176
6.3 Max & Unimotor SLM – High Performance Servos.....	144	Motion controller based SLM solution.....	176
Overview of M'Ax & SLM technology.....	144	MC Motion Co-ordinator.....	176
Feature performance.....	144	Motion Perfect Programming Software	
Ratings.....	147	SLM technology overview.....	178
Terminal diagram.....	147	Feature performance of M'Ax and	
Terminal description.....	148	MultiAx Servos.....	180
Specification.....	149	M'Ax Servo.....	181
Dimensions.....	150	Ratings	
Options.....	150	Terminal Diagram	
M'AxSoft.....	150	Terminal description	
Unimotor SLM.....	151	Specification	
Overview.....	151	Dimensions	
Specification.....	151	MultiAx Servo.....	185
Dimensions.....	152	Ratings	
Ratings.....	153	Terminal Diagram	
M'Ax & Unimotor SLM selection.....	154	Terminal Description	
M'Ax & Unimotor SLM speed torque curves.....	155	Specification	
Power & Signal Cable selection.....	156	Dimensions	
6.4 MiniAx and MM55.....	158	Unimotor SLM.....	186
Overview.....	158	Overview	
Feature performance.....	158	Specification	
Ratings.....	158	Performance data	
		Dimensions	

M'Ax & Unimotor SLM selection	
M'Ax & Unimotor SLM speed torque curves	
MultiAx & Unimotor SLM selection	
MultiAx & Unimotor SLM speed torque curves	
Power & Signal Cable selection	
Motion Control with SLM Partners.....	194
Trio Motion	
Delta Tau	
Nyquist	
Pantec	
Schliecher	
ISAC	
8 PLC Functionality with Unidrive 	208
Overview.....	208
Savings.....	208
Performance.....	208
Unidrive 	209
Applications Co-processor Modules.....	209
SM-Applications.....	209
SM-Applications Lite.....	210
Application Programming Software.....	210
Overview.....	210
	211
	211
Levels of PLC functionality.....	214
9 Set-up & Configuration Software	216
Drive Configuration Tools.....	216
Drive Sizing Software – CTSize.....	218
Energy Saving Tool – CTSave.....	219
10 Application Programming Software	220
Overview.....	220
Applications Co-processor Modules.....	220
	220
	221
Solutions Software.....	224
PowerTools Pro.....	228
11 Automation Hierarchy selection	230
Overview.....	230
Centralised.....	230
Decentralised.....	231
Hybrid.....	231
OPC Server.....	233
12 Networking Communications	234
12.1 CTNet	234
Overview.....	234
Application Co-processor Modules.....	234
Network Accessories.....	235
PC Network Interface Cards.....	235
Remote I/O.....	235
HMI Operator Interface.....	235
Application Programming Software.....	236
12.2 Fieldbus	237
PROFIBUS-DP.....	237
DeviceNet.....	237
INTERBUS.....	237
CANopen.....	238
CAN.....	238
CTNet.....	238
SERCOS.....	238
Ethernet.....	239
12.3 Operator Interfaces	241
HMI.....	241
SM Keypads.....	244
Universal Keypad.....	245
12.4 Power accessories	246
Dynamic Braking Resistors.....	246
Line and Load Reactors.....	247
EMC Filters.....	248
13 Soft Starters	250
14 Unimotors	254
Overview.....	254
Ordering information.....	255
Features.....	256
Specification.....	257
Nameplate.....	257
Performance data (std motor).....	258
Performance graphs (3000rpm).....	259
Performance data (UL motor).....	262
Dimensions.....	264
Feedback devices.....	265
Brake.....	266
Servo Gearboxes.....	267
Power and Signal cables.....	268
15 AC Motors (Inverter rated)	276
LSMV Inverter Rated.....	276
16 DC Motors	280
17 Linear Motors	284
Overview.....	284
Applications.....	284
Comparison of Linear & Rotary Motors.....	284
Linear Motors suitable for Unidrive 	285
Iron core synchronous	
Ironless core synchronous	
Tubular	
Unidrive  configuration parameters.....	286
Autotune.....	287
18 Training at Control Techniques	288
19 Symbols, Formulae and Conversion Tables	290
Symbols and Formulae.....	290
Protective Enclosures.....	291
Electrical Formulae.....	293
Mechanical Formulae.....	294
Inertia.....	296
Servo Formulae.....	298
Rectifier Power Conversion Formulae.....	300
Mechanical Conversion Tables.....	301
General Conversion Tables.....	304



Control Techniques – Solutions through Innovation

Innovation and application know-how has made Control Techniques one of the world's leading suppliers of drives, servos, controls and drive systems. Building on its ground breaking technologies and engineering excellence Control Techniques supplies today's diverse industry with a wide variety of motion control solutions – from the simple to the intricate – setting the standard with innovative design geared to machine productivity.

A History of Firsts

Control Techniques has shaped the history of drives and controls. It was among the first to offer an AC flux vector drive, and introduced the first digital DC drive, the first fully integrated servo drive, and the first universal AC and Servo drive – the Unidrive.



The recent introduction of the second generation Unidrive  - the benchmark for all AC and Servo drive technology – has seen Control Techniques consolidate its position as the leader in the field of drive based intelligence. Multiple operating modes, cost saving standard features and universal solution modules make the Unidrive  the most flexible and easily integrated high performance solutions drive available today.

Expert Global Support

Control Techniques supports an installed base of over two million drives throughout its fifty Drive and Application Centres located in over 30 countries. This network is backed up with an infrastructure of dedicated distributors in countries not covered by the Drive Centre network.

This network is uniquely focussed on the application of drives into machines with the express intention of giving the users greater control and/or productivity from their new or existing machine or process. Application support, documentation, field service are all available 24/7 to help our customers deliver on their promises.



The Commander SK above is the newest AC drive from Control Techniques, and is targeted at the simple and compact open loop drive market. Many of the Unidrive  innovations have been incorporated in this very economical general purpose drive.

Strength through Synergy

Control Techniques and our customers benefit from the strength, stability and synergy of being part of Emerson (NYSE: EMR), a \$15.6 billion company with over 60 divisions. Control Techniques and Emerson companies often work together to offer innovative and comprehensive solutions to our customers. Across applications and industries the synergy of Emerson and its divisions ensures that customers are always the focus of our attention.



Customer focused from concept to control solution

With its manufacturing headquarters and purpose built research and development based in Newtown, UK, Control Techniques has become a global 'no-compromise' drive supplier dedicated to the provision of customer driven solutions that deliver productivity improvements.



From its 14000sqm highly automated state of the art manufacturing facility, the team of engineers and skilled operators oversee the production of drives and servos to the very highest quality using the latest manufacturing techniques.

Control Techniques drives enable customers to deploy highly productive, easy to use motion solutions. Beyond achieving superior performance characteristics, the



design philosophy of Control Techniques is guided by customer input to produce truly 'user friendly' control solutions. As a result the drives are ergonomically designed for quick installation, simple set up, and easy maintenance; software tools are intuitive, consistent and flexible; and many advanced features are built into the drive as standard.

Modular controls enable drives to be tailored to the application. The SM-Applications modules snap into the Unidrive and allow a wide variety of integration activities to be undertaken easily and elegantly to give a truly scalable, tailored solution. PLC functionality without having to resort to typical PLC cost implications can be achieved using a combination of SM-Applications modules and ladder and function block programming.



Control Techniques gives users all the tools and options needed to tailor the drives to the application and operating environment. Often this is accomplished using option modules, which can provide expanded I/O, additional feedback options, fieldbus connectivity and greater programming flexibility.

Drive & Servo Range at a Glance

AC Drive kW	0.18	0.25	0.37	0.75	1.1	2.2	4	7.5	15	30	37	75	400	1200
Commander SX														
200V														
400V														
Commander SK														
200V														
400V														
Commander SE														
200V														
400V														
Unidrive 														
200V														
400V														
575V														
690V														

DC Drive kW	0.18	0.25	0.37	0.75	1.5	2.2	4	7.5	15	30	37	75	340	750
Puma														
220V														
Cheetah														
220V														
Lynx														
220V														
400V														
4Q2														
220V														
400V														
Mentor II														
200V														
400V														

Servo (A) Cont.	1.8	3.5	7	9.5	12	15	18	20	30	45	60	80	100	125	190	210
Epsilon																
200V																
Max																
400V																
MultiAx																
400V																
Unidrive 																
200V																
400V																
575V																
690V																

Drive Centre Engineered Solutions

Integrating drive solutions that deliver productivity

Control Techniques, established in 1973, are world leaders in the design and assembly of AC and DC drives and servos for the precise control of electric motors in machines and manufacturing processes.

Our unique focus is based on understanding your machine and process requirements and then integrating the best drive or servo solution to ensure you achieve maximum productivity at the lowest lifecycle cost. This 'machine-level drive integration' approach requires a high degree of industry knowledge from qualified application engineers. Our global network of Drive Centres are staffed by dedicated drives engineers focussed on how best to integrate our drives into your application.

- Local understanding of your machine or process
- Collaborative solution design for productivity
- Tailoring the drive solution to the machine or process



Precision drive-to-drive synchronisation with CTSync on the Unidrive has revolutionised the printing industry with new, "jitter free" 8- and 10-colour flexographic presses. Retrofits with this gearless technology are giving older presses new life and greater flexibility.

Local understanding of your machine or process



From elevators to hot rolling mills, from packaging machines to fans and pumps, variable speed drives and servos have a huge variety of applications. Control Techniques through its network of Drive Centre engineers has the local expertise to talk your language, and to understand how your machines and processes can benefit from the addition of precision drives and servos.

- Local engineers that are familiar with your applications and issues and available 24/7
- Understanding of local and industry compliance and conformance issues
- Focus on integrating the drive or servo to best enhance the machine's performance

Customers turn to Control Techniques for standard and customised automation solutions that deliver productivity.

Collaborative design to lower costs

Today's machine designers are continually searching for productivity enhancements, and our application engineers are integrating 'solutions drives' in such a way as to make productivity improvements a reality – at a lower total cost. Getting the best from integrating drives and servos into varied applications requires our engineers to be experts at matching the features of the drive with the customer's knowledge of his process to deliver tangible benefits. The Solutions Platform product portfolio from Control Techniques makes this a reality.

- Matching drive integration features to application or machine productivity goals
- True solutions platform drive approach based on incorporating years of experience into new drives
- Local experts always on hand to review and configure the solutions
- Flexible approach to engineering support and application software programming
- Highly qualified applications engineers focussed on drives and servos

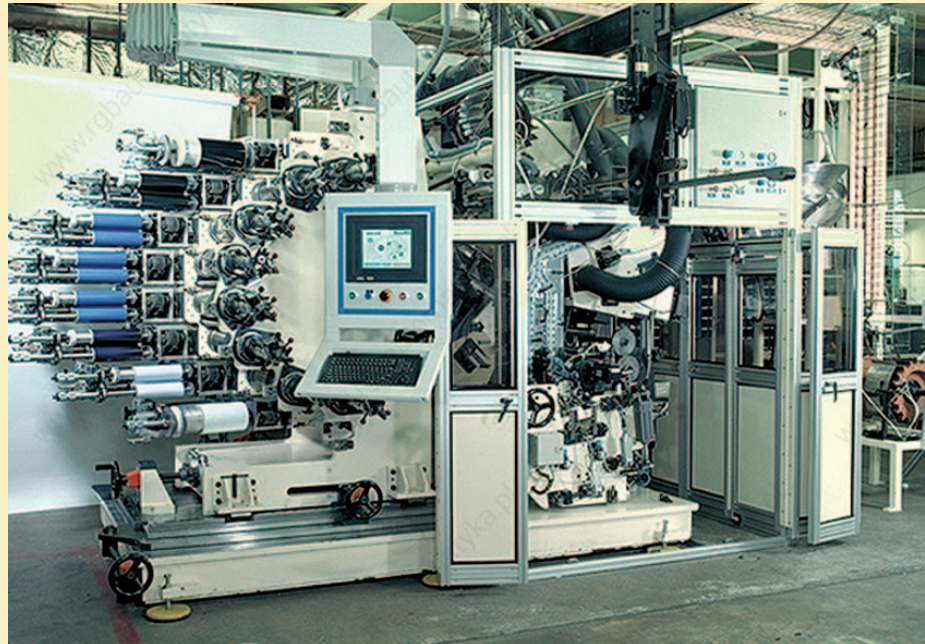

This oval-tube packaging printer has over 40 servomotors and several AC induction motors. Cost savings were achieved using the Unidrive SP with an SM-Applications module together with several Commander SE drives to complete this one-of-a-kind machine.

Tailoring the drive solution to the application



Unidrive's integration flexibility is making it the "standard" drive in automobile plants around the world. The rolling test rig performs simulated road testing of front-wheel, rear-wheel and four-wheel drive vehicles, checking motor, brake, and gearbox performance and road-noise decibel levels.

The key to successful drive integration projects stems from the flexibility of the drive, its options, its on-board intelligence and the different levels that these can be tailored to fit. From a clear understanding of the machine or process our drive engineers can tailor the solutions platform to deliver exactly the right integration solution – no more, no less than required. The flexibility of the drive and its features allows perfect matching of the drive to the application – and the most cost effective.

- Versatility of the drive solution platforms across industries and applications
- Adapt and scale the solution to cost effectively match the application
- Fieldbus flexibility to talk your language
- Scalable 'drive-based' PLC intelligence to release the true power of the drive technology

Drives, Servos and Controls that deliver productivity

Simple and Easy Drives

From cubicle based solutions in the form of Commander SK and Commander SE, to cubicle-free AC drives in Commander SX, the range offers users simplicity and functionality. The simple and easy approach to turning the motor shaft is the key to the Commander range but, in keeping with the Control Techniques approach to drive design, there are considerable solution integration options and possibilities to enable the discerning machine builder or process engineer to lower their overall costs. This is evident from the extra integration options available from Commander SK.

Solutions Platform Drives

The Unidrive $\mathcal{S}D$ AC range and the Mentor range of DC drives offer professional machine designers and process engineers unparalleled flexibility and integration possibilities for improving the performance of their machine or process. Drive Centre application engineers adapt the features and options of these Solutions drives and, via consultation and discussion, tailor these to your application.

Servos Drives

Unidrive $\mathcal{S}D$ is a class leading servo drive which with our other servo drives and motors offer engineers with responsibility for machine design the possibilities of integrating high performance motor control into their applications.



High Performance Motion Co-ordination

Accurate and dynamic control of multiple axis machinery requires a clear understanding of the application. The integration of Control Techniques drives into centralised (either PLC based, PC based, controller based) or decentralised solutions for the control of complex multi-axis solutions demands high performance drives and motors such as Unidrive SP, M'Ax, MultiAx and Epsilon.

Application software programming





Our Drive Centre engineers have years of experience in developing, writing, and programming drives in all industrial applications. Using IEC61131-3 ladder and function block programming, complex routines, once only possible using a PLC, can be written and carried out using the internally fitted options such as the SM-Applications co-processor.

Control Systems







The Drive Centre concept brings customers a compelling competitive advantage in being able to adapt our drives and servos into the most appropriate control system to meet their needs, and having designed the systems we can build, write software, test and commission locally.



GENERAL PURPOSE AC DRAWINGS

Product Range	Commander SE 	Commander SX 	Commander SK 																																				
Drives																																							
Control Technology	Open Loop	Open Loop	Open Loop																																				
Power	0.25 to 37kW	0.75 to 7.5kW	0.25 to 4kW																																				
AC Voltage 50/60Hz ± 10%	200V 1 phase 200V 3 phase 400V 3 phase	200V 1 phase 200V 3 phase 400V 3 phase	200V 1 phase 200V 3 phase 400V 3 phase																																				
Max Frequency	1000Hz	1000Hz	1500Hz																																				
Configuration & Programming	SESoft CT Comms Cable	SXSoft CT Comms Cable	CTSoft CT Comms Cable																																				
Memory	Quickey	XpressKey	SmartStick																																				
Power Accessories	External filter	On board filter External filter	On board filter External filter																																				
Motor Feedback	Open Loop	PX – Encoder for incremental encoders	Open Loop																																				
Input/Output on board	<table border="1"> <thead> <tr> <th></th> <th>Input</th> <th>Output</th> </tr> </thead> <tbody> <tr> <td>Digital</td> <td>5</td> <td>1</td> </tr> <tr> <td>Analog</td> <td>2</td> <td>1</td> </tr> <tr> <td>Relay</td> <td></td> <td>1</td> </tr> </tbody> </table>		Input	Output	Digital	5	1	Analog	2	1	Relay		1	<table border="1"> <thead> <tr> <th></th> <th>Input</th> <th>Output</th> </tr> </thead> <tbody> <tr> <td>Digital</td> <td>5</td> <td>1</td> </tr> <tr> <td>Analog</td> <td>2</td> <td>1</td> </tr> <tr> <td>Relay</td> <td></td> <td>1</td> </tr> </tbody> </table>		Input	Output	Digital	5	1	Analog	2	1	Relay		1	<table border="1"> <thead> <tr> <th></th> <th>Input</th> <th>Output</th> </tr> </thead> <tbody> <tr> <td>Digital</td> <td>5</td> <td>1</td> </tr> <tr> <td>Analog</td> <td>2</td> <td>1</td> </tr> <tr> <td>Relay</td> <td></td> <td>1</td> </tr> </tbody> </table>		Input	Output	Digital	5	1	Analog	2	1	Relay		1
	Input	Output																																					
Digital	5	1																																					
Analog	2	1																																					
Relay		1																																					
	Input	Output																																					
Digital	5	1																																					
Analog	2	1																																					
Relay		1																																					
	Input	Output																																					
Digital	5	1																																					
Analog	2	1																																					
Relay		1																																					
Input/Output options		PX – I/O Extended I/O	SM-I/O Lite SM-I/O Timer with real time clock SM-PELV – Double insulated I/O to NAMUR specification SM-I/O 120V																																				
Communication	MODBUS SE-PROFIBUS DP SE-DeviceNet SE-CANopen SE-INTERBUS	MODBUS SM-PROFIBUS DP SM-DeviceNet SM-CANopen SM-INTERBUS	MODBUS SM-PROFIBUS DP SM-DeviceNet SM-CANopen SM-INTERBUS SM-Ethernet																																				
Application Co-processor Modules			LogicStick																																				
Application Programming Software			 SyPTLite – IEC61131-3 ladder and function block programming																																				
Solutions Software																																							
Approvals	UL, CUL, CE, C-Tick, ISO 14001, ISO9001:2000	UL, CUL, CE, C-Tick, ISO 14001, ISO9001:2000	UL, CUL, CE, C-Tick, ISO 14001, ISO9001:2000																																				

SOLUTIONS PLATFORM AC AND DC DRIVES

 <p>Unidrive SP</p>	 <p>Mentor II</p>	<p>Product Range</p>																					
<p>Open loop, Closed loop, Servo, Regen</p>	<p>Closed loop</p>	<p>Drives</p>																					
<p>0.75 to 1200kW</p> <p>200V 1 phase 200V 3 phase 400V 3 phase 575V 3 phase 690V 3 phase</p>	<p>3.75 to 750kW</p> <p>200V 3 phase, 400V 3 phase 525V 3 phase, 600V 3 phase</p>	<p>Control Technology</p> <p>Power</p> <p>AC Voltage 50/60Hz ± 10%</p>																					
<p>3000Hz (Open Loop) 1250Hz (Closed Loop)</p>		<p>Max Frequency</p>																					
<p>CTSoft CT Comms Cable</p>	<p>MentorSoft</p>	<p>Configuration & Programming</p>																					
<p>SmartCard</p>		<p>Memory</p>																					
<p>On Board Filter, External Filter Braking Resistor</p>	<p>Braking Resistor, External Filter FXM Field Regulator</p>	<p>Power Accessories</p>																					
<p>On Board Universal Encoder Port SM-Resolver SM-Encoder Plus SM-Universal Encoder Plus</p>	<p>Tacho Encoder</p>	<p>Motor Feedback</p>																					
<table border="1"> <thead> <tr> <th></th> <th>Input</th> <th>Output</th> </tr> </thead> <tbody> <tr> <td>Digital</td> <td>4</td> <td>3*</td> </tr> <tr> <td>Analog</td> <td>3</td> <td>2</td> </tr> <tr> <td>Relay</td> <td></td> <td>1</td> </tr> </tbody> </table> <p>*Programmable in/out</p>		Input	Output	Digital	4	3*	Analog	3	2	Relay		1	<table border="1"> <thead> <tr> <th></th> <th>Input</th> <th>Output</th> </tr> </thead> <tbody> <tr> <td>Digital/Logic</td> <td>12</td> <td>7</td> </tr> <tr> <td>Analog</td> <td>5</td> <td>5</td> </tr> </tbody> </table>		Input	Output	Digital/Logic	12	7	Analog	5	5	<p>Input/Output on board</p>
	Input	Output																					
Digital	4	3*																					
Analog	3	2																					
Relay		1																					
	Input	Output																					
Digital/Logic	12	7																					
Analog	5	5																					
<p>SM-I/O Lite SM-I/O Plus, SM-I/O 120V SM-I/O Timer with real time clock SM-PELV – Double insulated I/O to NAMUR specification Remote I/O</p>	<p>I/O Box Remote I/O</p>	<p>Input/Output options</p>																					
<p>MODBUS SM-PROFIBUS DP SM-DeviceNet SM-CANopen SM-INTERBUS SM-Ethernet SM-CAN SM-SERCOS SM-SLM CTNet</p>	<p>MODBUS PROFIBUS DP DeviceNet Modbus Plus INTERBUS CTNet</p>	<p>Communication</p>																					
<p>SM-Applications Lite SM-Applications, SM-EZMotion</p>	<p>MD29, MD29AN</p>	<p>Application Co-processor Modules</p>																					
<p> SyPTPro – IEC61131-3 ladder and function block programming  SyPTLite – a subset of  SyPTPro PowerTools Pro</p>	<p> SyPTPro – IEC61131-3 ladder and function block programming</p>	<p>Application Programming Software</p>																					
<p>Winder, Fan and Pump Duty Assist, Flying Shear</p>	<p>Winder, Flying Shear</p>	<p>Solutions Software</p>																					
<p>UL, CUL, CE, C-Tick, ISO14001, ISO9001:2000</p>	<p>UL, CUL, CE, C-Tick, ISO14001, ISO9001:2000</p>	<p>Approvals</p>																					

Commander SK

Simplicity with Functionality

OVERVIEW

Commander SK has been designed as a simple, compact, cost effective AC motor speed controller that delivers performance with simplicity and ease of use. With all the parameters you need for 90% of applications printed on the front of the drive, Commander SK ensures installation and commissioning are straight forward.

THE BENCHMARK
in simple drives

However, for more demanding applications, Commander SK can deliver the benchmark functionality of its larger Solutions Platform products and at no extra cost on the base drive itself. Plug-in options, dynamic performance, PLC functionality and other benchmark features ensure that in more complex applications Commander SK can deliver more than the average general purpose drive – giving you lower cost solutions and better productivity in your motor control applications.

- From 0.25 to 2.2kW, 1 phase 200V
- From 1.1 to 2.2kW, 3 phase 200V
- From 0.37 to 4.0kW, 3 phase 400V

Simplicity

- Easy to set-up – all the parameters you need (90% of typical applications) are printed on the front
- Easy installation – choose between simple panel mounting and DIN-rail mounting (up to 1.5kW)
- Simple connections – easy access terminals with clear marking
- Simple start-up – easy push button set-up – no need for complex programming

Functionality

- Communications – the popular global fieldbus options are available PROFIBUS-DP, INTERBUS, DeviceNet, CANopen, Ethernet
- PLC Functionality – LogicStick and IEC61131-3 ladder and function block programming
- Wide range of I/O – extra I/O options available including Real Time Clock
- Performance – inherits the torque linearity and speed torque performance from the Solution Platform products

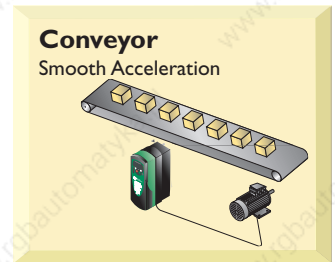
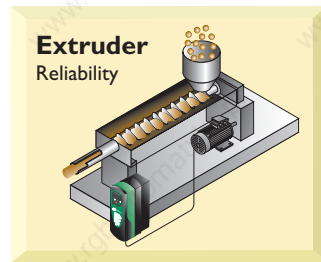
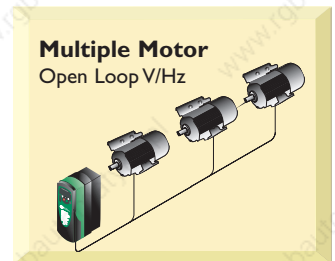
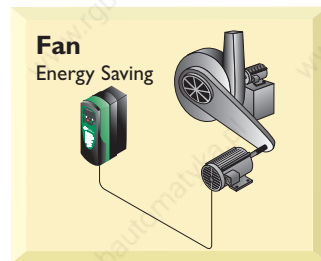
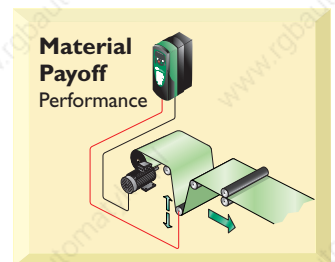
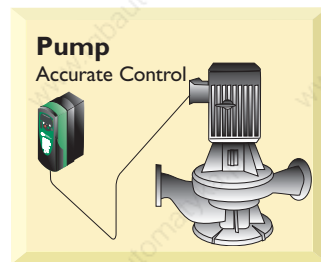

Size A Size B & C



Submitted for UL listing



FEATURE PERFORMANCE

Open loop vector control with true space vector modulation

Precise control algorithm provides full torque down to 1 Hz for exceptional performance

Access to multiple parameter levels

Customises the drive to meet each user's needs: simple (level 1), flexible (level 2) and advanced (level 3)

SmartStick cloning module

Provides fast and cost-effective drive-to-drive parameter transfer and storage with no PC required

Terminal connection drawings and Level 1 parameters (10) listed on the drive's front cover

On-the-spot easy reference for drive set-up and maintenance

Static auto-tune

Allows fast motor / drive optimisation without motor shaft rotation

Two sets of motor map parameters saved in the drive's memory

Allows sequenced switching between two motors with different operating characteristics

Configurable analog and digital I/O

Customises drive to the specific application

S-ramp accel / decel profiling

Provides smooth speed transitions, minimising machine "jerk"

Built-in independent PID control

Eliminates the need for an external PID controller while providing "outer loop" control of a process variable

Real Time Clock option

For scheduling and timing operations

Wide range of industry standard fieldbuses

Modbus RTU (Standard), PROFIBUS-DP, INTERBUS, DeviceNet, CANopen, Ethernet

Replace nano and micro PLCs by using LogicStick and IEC61131-3 ladder and function block programming

RATINGS

200 to 240V ± 10% 48 to 62Hz					
Order Code	Frame Size	Motor kW ^①	Input Phases	Contin. Output Current (A)	Overload Current ^② (A)
SKA1200025	A	0.25	1	1.7	2.6
SKA1200037	A	0.37	1	2.2	3.3
SKA1200055	A	0.55	1	3.0	4.5
SKA1200075	A	0.75	1	4.0	6.0
SKBD200110	B	1.1	1 or 3	5.2	7.8
SKBD200150	B	1.5	1 or 3	7.0	10.5
SKCD200220	C	2.2	1 or 3	9.6	14.4

380 to 480V ± 10% 48 to 62Hz					
Order Code	Frame Size	Motor kW ^①	Input Phases	Contin. Output Current (A)	Overload Current ^② (A)
SKB3400037	B	0.37	3	1.3	2.0
SKB3400050	B	0.55	3	1.7	2.6
SKB3400075	B	0.75	3	2.1	3.2
SKB3400110	B	1.1	3	2.8	4.2
SKB3400150	B	1.5	3	3.8	5.7
SKC3400220	C	2.2	3	5.1	7.7
SKC3400300	C	3.0	3	7.2	10.8
SKC3400400	C	4.0	3	9.0	13.5

① Motor power is based on four pole, 230 / 460 VAC NEMA ratings.

② Overload: 150% for one minute.

Order Code					
SK	X	X	XX	XXXX	
				Drive Kilowatt Rating	
				Drive Voltage Rating: 20 = 200-240 VAC 40 = 380-480 VAC	
				Input Phase: 1 = 1ph, D = 1ph & 3ph, 3 = 3ph	
				Size: A, B, C	
Commander SK product family name					

TERMINAL DIAGRAM

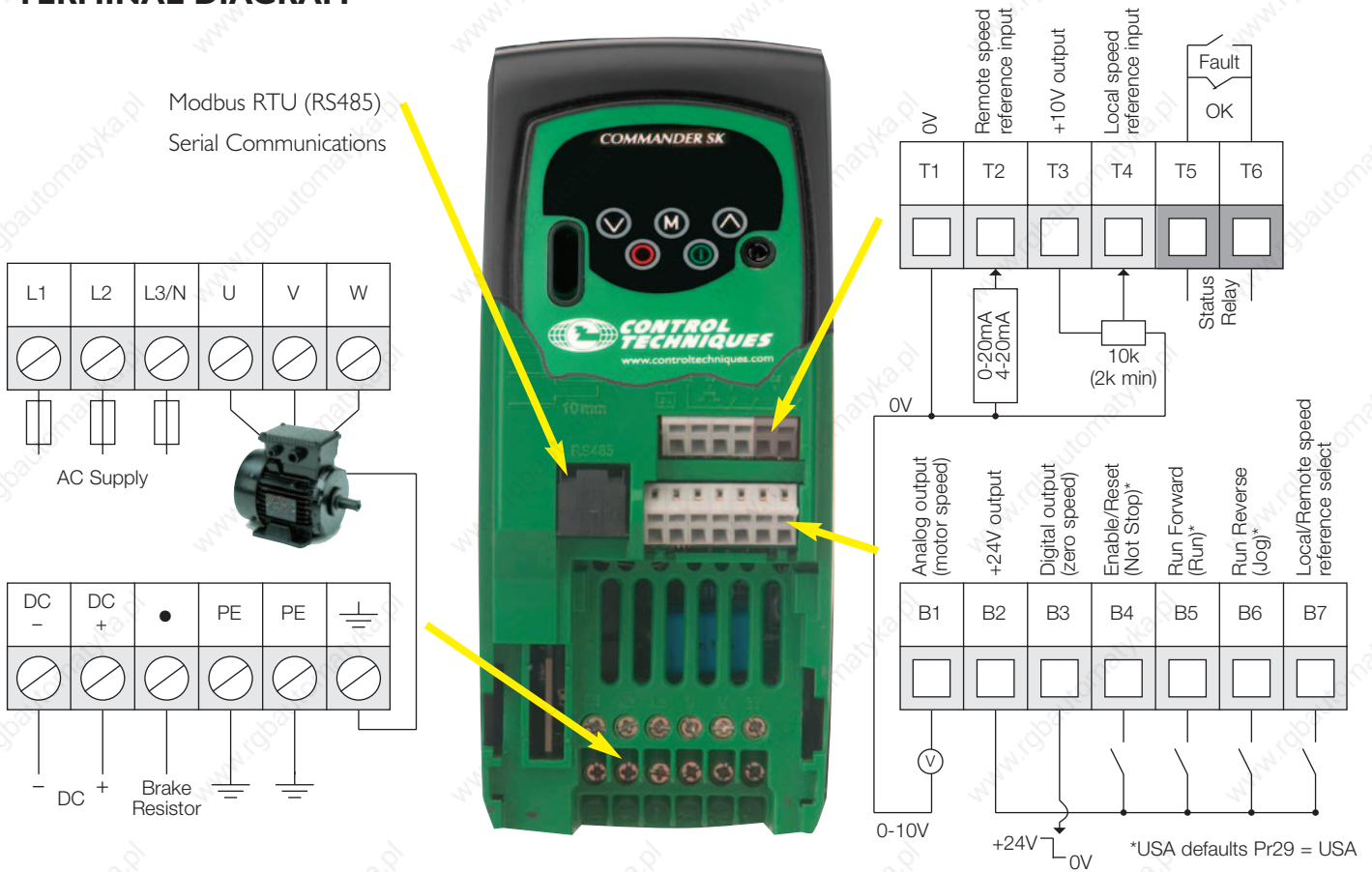

Commander SK Terminal Diagram: Terminal Description

TERMINAL DESCRIPTION

Ter.	Type/Description	Default function	Notes
T1	0V Common	Common for External Analog Signals	
T2	Analog Input 1 (A1) either voltage or current	Single-ended Analog Input	0 to +10 VDC, 100k Ohms, Sample Time 6ms
T3	+10VDC	Reference Supply	5 mA max Short Circuit Protected
T4	Analog Input 2 (A2) or Digital Input	Single-ended Analog Input	0 to +10VDC (AI), 0 to +24VDC (DI) Sample Time 6ms
T5 T6	Status Relay (Normally open)	Drive healthy	240AC 30 VDC, 2A/6A resistive
B1	Analog Output 1 single ended Unipolar	Motor speed	0 to +10VDC @ 5 mA max Update Time 6ms
B2	+24VDC Output	User Supply	100 mA max
B3	Digital (Output)	Zero speed	0 to 24VDC, 6.8k Ohms input Update Time 1.5ms

Ter.	Type/Description	Default function	Notes
B4	Digital Input	Enable/Reset (not stop)	0 to 24VDC, 6.8k Ohms Update Time 1.5ms
B5	Digital Input	Run forward (run)	0 to 24VDC, 6.8k Ohms Update Time 1.5ms
B6	Digital Input	Run reverse (jog)	0 to 24VDC, 6.8k Ohms Update Time 1.5ms
B7	Digital Input	Local/Remote Speed reference select AI/A2	0 to 24VDC, 6.8k Ohms Update Time 1.5ms

Programmable Analog Programmable Digital
 All Analog I/O is scalable

① 4-20, 20-4, 0-20, 20-0mA are also available. See Commander SK Getting Started Guide.

② Brackets indicate North American default function when different.

SPECIFICATION

Control

- Open loop vector control
- Speed or torque control
- Speed reference input: 0-10V, 0-20 mA, 4-20 mA, (-10 to +10V SM-I/O Lite option)
- 4 digital inputs
 - World (enable, run forward, run reverse, local/remote)
 - USA (not stop, run, jog, local/remote)
- Switching frequency: 3 (default) – 6 – 12 – 18 kHz
- Output frequency 0 to 1500 Hz
- Accel and Decel ramps (linear and S type)
- Positive logic control
- Serial communication
 - Modbus RTU RS485 via RJ45 connector
 - Baud rate 4800, 9600, 19200 or 38400 bits per second
- DC injection braking as standard
- Dynamic braking transistor as standard
- Dynamic motor flux V/Hz for energy saving
- Quadratic motor flux V/Hz for fan and pump optimisation

Protection

- Undervoltage, Supply and DC Link overvoltage, Phase loss, Drive overload, Instantaneous overcurrent, Short circuit, Ground fault, Drive thermal, Watchdog, Motor thermal

General Characteristics

- Maximum overload 150% of rated current for 60s
- Intelligent Thermal Management (ITM) optimises switching frequency
- 8 preset speeds
- Flying start
- Mains dip ride through
- Automatic no-spin autotune for fast performance optimisation
- Keypad access to all parameters for more demanding set-ups

Environment

- IP20
- NEMA 1 rating with optional cover
- Ambient temperature -10 to +40°C @ 3 kHz switching
- Humidity 95% maximum (non-condensing)
- Electromagnetic Immunity complies with EN61800-3 and EN61000-6-3 and 4
- Electromagnetic Emissions complies with EN61800-3 (second environment) as standard. Complies with EN61000-6-3 (residential) and EN61000-6-4 (industrial) generic standards with optional footprint EMC filter

Approvals & Listings

UL, cUL	UL File Listed 8D14
IEC	Meets IEC Vibration, Mechanical Shock and Electromagnetic Immunity Standards
CE	Low Voltage Directive
NEMA	NEMA 1 enclosure type
ISO 9001:2000	Certified Manufacturing Facility
ISO 14001	Certified Manufacturing Facility

DIMENSIONS (mm)

Drive size	w	h	d
	mm	mm	mm
A	75	140	145
B	85	190	156
C	100	240	173



OPTIONS

Overview

Commander SK has been designed to offer simplicity, but with the impressive selection of benchmark options and standard features it also offers functionality that enables users to get more productivity from their machines.

Users that scratch the surface of this simple drive will reveal a list of dynamic yet functional options that owe a lot to the ground breaking Solution Platform products such as Unidrive SP, that are in the Control Techniques product portfolio.

Options At-A-Glance

Option	Description	Order Code
Drive Configuration & Programming	Configuration Tool	CTSoft
	RS232/485 Cable	CT Comms Cable
	Cloning and parameter storage	SmartStick
Operator Interfaces	Remote LED display	SK-Keypad Remote
	Remote LCD display	SM-Keypad Plus
	HMI Operator Interfaces	See Section 12.3
Power Accessories	Internal EMC Filter	Standard
	External EMC Filter	To fit drive
	Braking Resistor	To fit drive
	Bottom metal gland plate cover	Gland cover Size A, B or C
	Top cover for NEMA 1 installations	Top cover Size A, B or C
	Universal cable management bracket	SK-Bracket
	Input/Output	Extended I/O
	Extended I/O plus Real Time Clock	SM-I/O Timer
	Double Insulated Extended I/O	SM-PELV
	120V Extended I/O	SM-I/O 120V
Communication	Modbus RTU	Standard
	PROFIBUS-DP	SM-PROFIBUS-DP
	DeviceNet	SM-DeviceNet
	CANopen	SM-CANopen
	ETHERBUS	SM-ETHERBUS
Application Programming Software (IEC61131-3)	Ladder and function block programming	SyPT Lite
	Memory for SyPT Lite program	LogicStick



DRIVE CONFIGURATION AND PROGRAMMING

Drive Configuration Tool

CTSoft software is a complimentary PC or laptop Windows™ based drive configuration tool designed to enable the complete control and display of all parameters within a Commander SK. Functions within CTSoft allow data to be uploaded, viewed and saved, or retrieved from disk, modified and printed. It can be used off-line in the office or on-line in the factory. CTSoft communicates with the Commander SK via the computer's serial port to the drive's RS485 port using a communications cable (CT Comms Cable).

Some of CTSoft's capabilities include:

- Remote Upload/Download
- Parameter Saving
- Monitor Screens
- Multiple Window Display
- Block Diagram Animation
- Project Storage

CTSoft IS SUPPLIED WITH THE DRIVE OR YOU CAN DOWNLOAD FROM www.controltechniques.com/download.htm

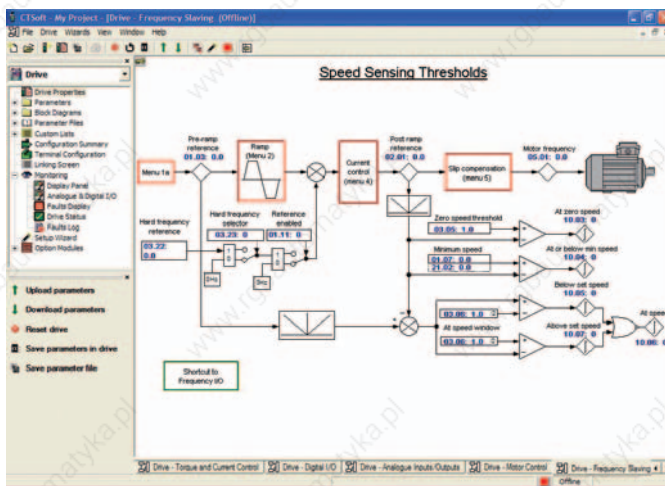

Communications Cable

Using an isolated serial to RS485 converter you can connect the PC/laptop to the RJ45 serial port on the front of the drive.



A special pre-made cable is available from

Control Techniques for this purpose – this same cable is also used with other Control Techniques products that use a RJ45 RS485 connector such as the Unidrive .

Description	Order Code
PC-to-drive Comms Cable	CT Comms Cable
USB-to-drive Comms Cable	USB CT Comms Cable

SmartStick

This option enables the simple set up of parameters in a variety of ways. The SmartStick can:

- 'Clone' a complete set of parameters from the first drive to multiple drives (perfect for serial production)
- Download parameter settings to the drive to easily set up your application
- Automatically save the user parameter set up for storage and maintenance purposes
- Load complete motor map parameters



The drive only communicates with the SmartStick when commanded to read or write, meaning that it may be "hot swapped".



Description	Order Code
Cloning and parameter storage	SmartStick

OPERATOR INTERFACES

Keypad Options

The Commander SK can operate and be set up using the standard fixed keypad, or with either the SK-Keypad Remote or SM-Keypad Plus. The SK-Keypad Remote is a full-function, 7-digit LED data display. The SM-Keypad Plus is a back-lit LCD display option that can be remote mounted, has 5 languages, plus custom text database, on-line help, and HMI features. Both keypads are “hot-pluggable,” enabling them to be moved from one drive to another without powering down.



SK-Keypad Remote



SM-Keypad Plus

Description	Order Code
Remote panel mounting LED display to IP54 (NEMA 12) with additional function key	SK-Keypad Remote
Remote panel mounting LCD multilingual text keypad display to IP54 (NEMA 12) with additional help key	SM-Keypad Plus

Operator Interface Unit (HMI)

The HMI operator interface units have a range of features including a back-lit LCD display and easy-to-use navigation keys. Using the intuitive “WYSIWIG” page editor, they can be programmed to display a variety of menus, submenus, alarms, fault conditions and other critical information. The HMIs support a range of capabilities including multiple font sizes, real time trends and graphs, scheduling and background programs. They communicate* via Modbus RTU and, to simplify installation, some HMIs are rated IP54 and require no screw mounting holes.

For more information, refer to the Network Communications Section 12.3.



HMI 200

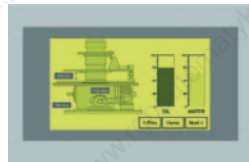

VTI55W



TIU500

POWER ACCESSORIES

Dynamic Braking Resistors

Dynamic braking resistors provide a means of rapidly decelerating or stopping the motor and load. The mechanical energy stored in the spinning mass is converted into electrical energy by the drive and then quickly dissipated into the resistor.

Onboard EMC Filter

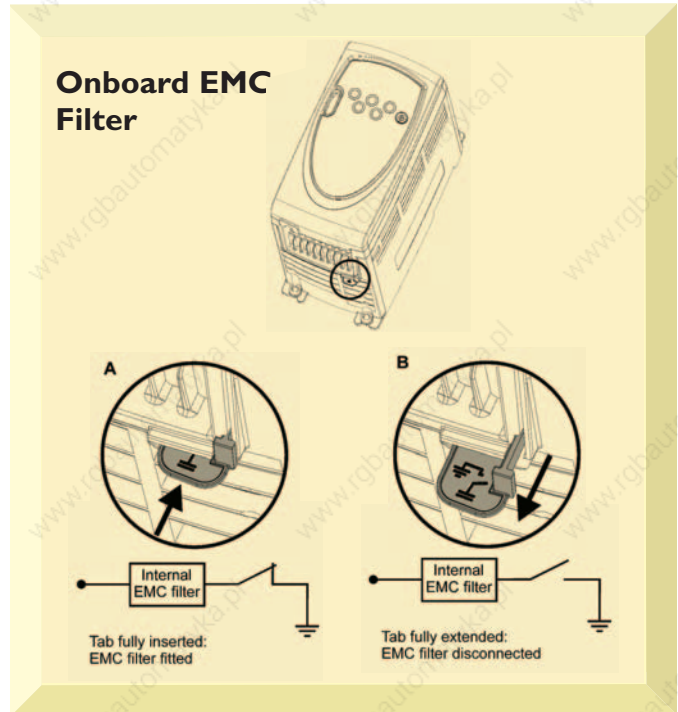

An internal EMC filter is provided as standard with the Commander SK which is adequate for most industrial applications. The drive and filter conforms to EN61800-3 (second environment). For installations where it is deemed necessary, Control Techniques provide a range of additional external EMC filters. The internal filter can be easily removed if the drive is to be used on IT supplies or with low earth leakage external EMC Footprint filters.

External EMC filters

EMC filters are used to minimise high frequency power supply line disturbances caused by PWM AC drives that may interfere with proper operation of sensitive electronic equipment. These specific filters have been assessed for conformance with the EMC directive by testing with the appropriate Control Techniques drives.

Two Mounting Styles in One

- Bookend: filter mounts next to the drive with the smallest dimension being the width of the filter
- Footprint: filter mounts between the drive heatsink and the panel or enclosure



Footprint EMC Filter Description	Voltage	Order Code
SK-EMC Filter Size A 1 Phase	200 to 240V +/- 10% 1ph	4200-6122
SK-EMC Filter Size B 1 Phase	200 to 240V +/- 10% 1ph	4200-6212
SK-EMC Filter Size B 3 Phase	380 to 480V +/- 10% 3ph	4200-6213
SK-EMC Filter Size C 1 Phase	200 to 240V +/- 10% 1ph	4200-6310
SK-EMC Filter Size C 3 Phase	380 to 480V +/- 10% 3ph	4200-6311

Single phase footprint filters for low earth leakage applications	Voltage	Order Code
SK-EMC Low Leakage Size A	200 to 240V +/- 10% 1ph	4200-6122
SK-EMC Low Leakage Size B	200 to 240V +/- 10% 1ph	4200-6212
SK-EMC Low Leakage Size C	380 to 480V +/- 10% 3ph	4200-6213

INPUT/OUTPUT

Extended I/O

Description	Order Code
Additional I/O option with the following connections	SM-I/O Lite

Terminal Function

- 1 0V
- 2 ± bi-polar or 4-20mA Analogue input
- 3 0-10V or 4-20mA Analogue output
- 4 +24V
- 5 Digital input
- 6 Digital input
- 7 Encoder B or Digital input
- 8 Encoder B\
- 9 Encoder A
- 10 Encoder A\
- 11 0V
- 12 Encoder +5V
- 13 Relay
- 14 Relay
- 15 Relay



This 'Encoder Speed Reference' input is not a true quadrature counter – therefore applications which require accuracy when operating close to zero speed will not be possible. Therefore, generally the option cannot be used for position applications but is more suited to applications that require accurate speed holding and speed following.

Extended I/O with Real Time Clock

(Year, Month, Date, Week Day, Hour, Minute, Second)

Description	Order Code
Real Time Clock for scheduling drive running as well as the following additional I/O connections:	SM-I/O Timer

Terminal Function

- 1 0V
- 2 ± bi-polar or 4-20mA Analogue input
- 3 0-10V or 4-20mA Analogue output
- 4 +24V
- 5 Digital input
- 6 Digital input
- 7 Encoder B or Digital input
- 8 Encoder B\
- 9 Encoder A
- 10 Encoder A\
- 11 0V
- 12 Encoder +5V
- 13 Relay
- 14 Relay
- 15 Relay



This 'Encoder Speed Reference' input is not a true quadrature counter – therefore applications which require accuracy when operating close to zero speed will not be possible. Therefore, generally the option cannot be used for position applications but is more suited to applications that require accurate speed holding and speed following.

Commander SK
Input/Output

Double Insulated Extended I/O

Description	Order Code
Double Insulated Extended I/O	SM-PELV

Chemical industry conformance to NAMUR NE37 gives security in demanding application environment.



120V Extended I/O

Description	Order Code
120V Digital I/O	SM-I/O 120V

120V Digital inputs/outputs for applications with 120V control voltage.

COMMUNICATION

Fieldbus Options

The most popular industrial fieldbus protocols are available in the SM range of option modules.

One option slot in sizes B and C allows an SM fieldbus option and or an extended I/O SM option module to be fitted.



Ethernet

MODBUS RTU

SM-DeviceNet

SM-PROFIBUS-DP



SM-CANopen

SM-INTERBUS

SM-Ethernet



Communications Protocol	Order Code
Modbus RTU*	Standard
PROFIBUS-DP	SM-PROFIBUS-DP
INTERBUS	SM-INTERBUS
DeviceNet	SM-DeviceNet
CANopen	SM-CANopen
Ethernet	SM-Ethernet

Use fieldbus firmware version 3.0 or higher for complete compatibility for the entire range of AC drives

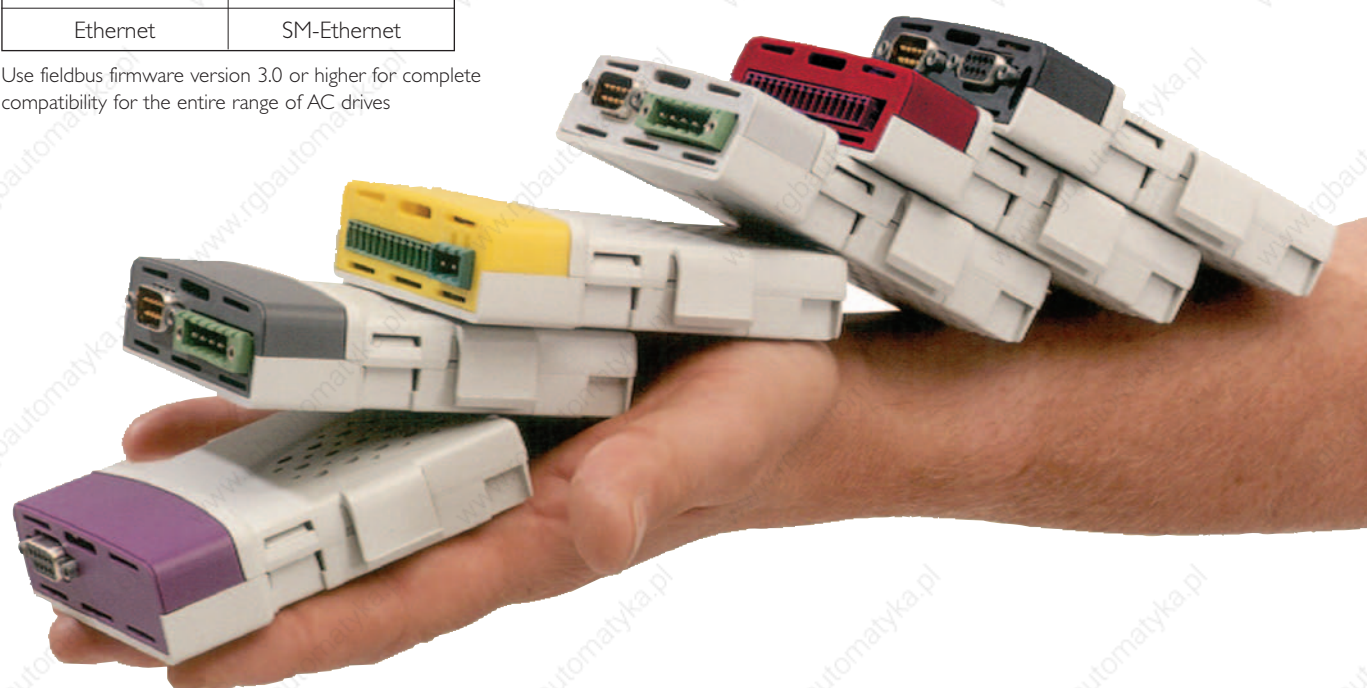

PROGRAMMING SOFTWARE

SyPTLite with LogicStick

Commander SK is Control Techniques' simple and easy-to-use general-purpose drive. However, Commander SK contains features and functions that you may not expect to find on a low-cost drive, such as the flexibility to program PLC applications onboard the drive. By inserting a LogicStick into the front of the drive, you quickly add memory for program storage that allows you to write a PLC ladder program using SyPTLite. The drive is prioritised to execute all motor control related functions first and will use any remaining processing time to execute the SyPTLite ladder program as a background activity. Commander SK may also be fitted with the SM-I/O Timer option that incorporates a real-time clock, allowing the drive to be used as a low-cost stand alone solution in a wide range of applications such as dosing, lubricating, heating and ventilation.



SyPTLite IEC 61131-3

Ladder Programming Software

SyPTLite is a ladder diagram editor that allows you to develop programs that can be executed onboard Commander SK with LogicStick.

SyPTLite is designed to meet the needs of the majority of automation users wishing to extend the functionality of the drive control and sequencing. The software has been developed with a definite focus on intuitive ease of use allowing you to quickly access all of the drive's parameters and to monitor and debug your ladder program on line.

Description	Order Code
Software for your PC or laptop which allows you to program PLC functions within the drive. Use with LogicStick and CTComms cable	SyPTLite
The LogicStick plugs into the front of the drive and enables you to program PLC functions within the drive	LogicStick

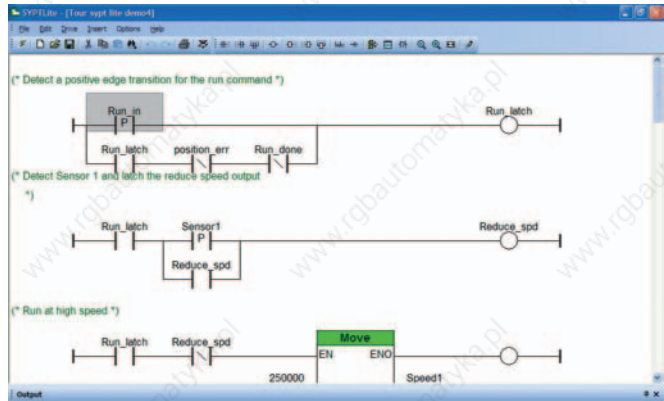

SyPTLite contains a comprehensive library of functions that is based on a subset of those available in the SyPTPro programming tool. These include:

- Arithmetic Blocks
- Comparison Blocks
- Timers
- Counters
- Multiplexers
- Latches
- Bit Manipulation

SyPTLite IS PROVIDED FREE OF CHARGE WITH THE DRIVE OR VISIT www.controltechniques.com/download.htm

Commander SE

Simple and Easy

OVERVIEW

Control Techniques' economical microdrive is an AC open loop vector powerhouse, combining unmatched flexibility with a small footprint. Best of all, the Commander SE is simple to use and easy to install.

The Commander SE's first 10 parameters meet the needs of nearly 80% of drive applications, making setup fast and effortless. Installation requires only a standard screwdriver, while the removable control terminal strip makes changeover quick and error free.

The rugged and robust design has been field tested in harsh environments and proven itself a dependable drive for a wide range of applications. The Commander SE, with its Intelligent Thermal Management (ITM) technology, was designed with reliability in mind. Rated at 50°C ambient temperature, the Commander SE withstands the most severe operating conditions.



- **Digital AC Drive**
- **0.25 to 2.2kW, 1 phase, 200 to 240 VAC**
- **0.75 to 7.5kW, 3 phase, 200 to 240 VAC**
- **0.75 to 37kW, 3 phase, 380 to 480 VAC**
- **IP21 (NEMA1) enclosure**
- **RS485 serial communications with Modbus RTU protocol**
- **Plug-in communications via PROFIBUS-DP, DeviceNet, INTERBUS, and CANopen**
- **SESoft Windows based configuration tool for PC/Laptop**
- **QuickKey cloning module**
- **Advanced menus for ultimate control and flexibility**

Mixer

Simple and Easy

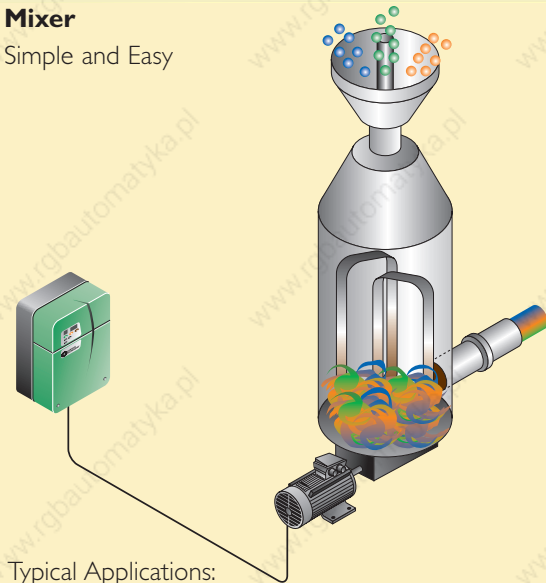

Typical Applications:
Fans, Pumps, Conveyors, Blowers, Ovens, Chillers

Material Payoff

Performance

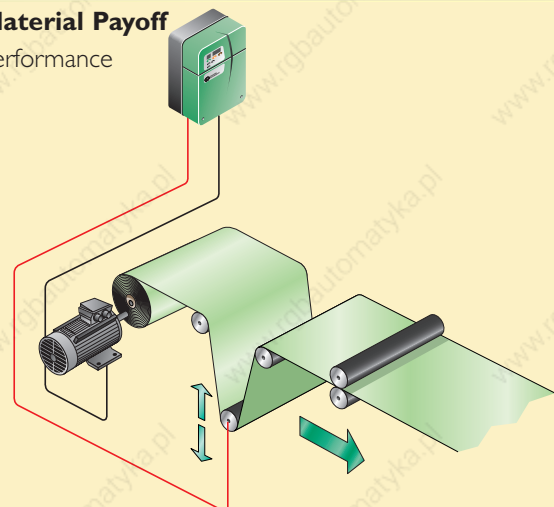

Typical Applications: Material Handling, Lifts



FEATURE PERFORMANCE

Open loop vector control with true space vector modulation

Precise control algorithm provides full torque down to 1 Hz for exceptional performance

Access to multiple parameter levels

Customizes the drive to meet each user's needs: simple (level 1), flexible (level 2) and advanced (level 3)

QuicKey cloning module

Provides fast and cost-effective drive-to-drive parameter transfer and storage with no PC required

Terminal connection drawings and Level 1 parameters (I0) listed on the drive's front cover

On-the-spot easy reference for drive set-up and maintenance

Static auto-tune

Allows fast motor / drive optimization without motor shaft rotation

Two sets of motor map parameters saved in the drive's memory

Allows sequenced switching between two motors with different operating characteristics

Configurable analog and digital I/O

Customizes drive to the specific application

S-ramp accel / decel profiling

Provides smooth speed transitions, minimizing machine "jerk"

Built-in independent PID control

Eliminates the need for an external PID controller while providing "outer loop" control of a process variable

Built-in Motorised Potentiometer

Emulates the functionality of the traditional Motorised Potentiometer with increase / decrease pushbuttons

8 Preset speeds with independent accel / decel ramps

Allows predetermined speed sequencing via logic inputs

Selectable Stopping modes including Ramp, Coast, DC Injection, and Dynamic Braking (except size I)

Added flexibility meets many application requirements

Full EMC compliance with optional filter

Meets global standards for worldwide use

RATINGS

SINGLE OR THREE PHASE INPUT

0.25 to 7.5kW 200-240V±10%

0.75 to 37kW 380-480V±10%

200 to 240V ± 10%

Order Code	Frame Size	Motor kW ^①	Input Phases	Conti. Output Current (A)	Overload Current ^② (A)
SE11200025	I	0.25	I	11.5	2.25
SE11200037	I	0.37	I	2.5	3.45
SE11200055	I	0.55	I	3.1	4.65
SE11200075	I	0.75	I	4.3	6.45
SE2D200075	2	0.75	I or 3	4.3	6.45
SE2D200150	2	1.5	I or 3	7.5	11.3
SE2D200220	2	2.2	I or 3	10	15
SE23200400	2	4	3	17	25
SE33200550	3	5.5	3	25	37.5
SE33200750	3	7.5	3	28.5	42.8

380 to 480V ± 10%

Order Code	Frame Size	Motor kW ^①	Input Phases Current (A)	Conti. Output (A)	Overload Current ^②
SE23400075	2	0.75	3	2.1	3.2
SE23400150	2	1.5	3	4.2	6.3
SE23400220	2	2.2	3	5.8	8.7
SE23400400	2	4.0	3	9.5	14.3
SE33400550	3	5.5	3	13	19.5
SE33400750	3	7.5	3	16.5	24.8
SE43401100	4	11	3	24.5	36.8
SE43401500	4	15	3	30.5	45.8
SE43401850	4	18.5	3	37	55.5
SE53402200	5	22	3	46	69.0
SE53403000	5	30	3	60	90.0
SE53403700	5	37	3	70	105.0

Use new Commander SK, see page 14

① Motor Power is based on four pole, 230 / 460 VAC NEMA ratings.

② Overload: 150% for one minute.

Order Code

SE	X	X	XX	X	X	X	X
				Drive Kilowatt Rating			
				Drive Voltage Rating: 20 = 200-240 VAC			
				40 = 380-480 VAC			
				Input Phase: I = 1ph, D = 1ph & 3ph, 3 = 3ph			
				Size: 1, 2, 3, 4, 5			
				Commander SE product family name			

TERMINAL DIAGRAM

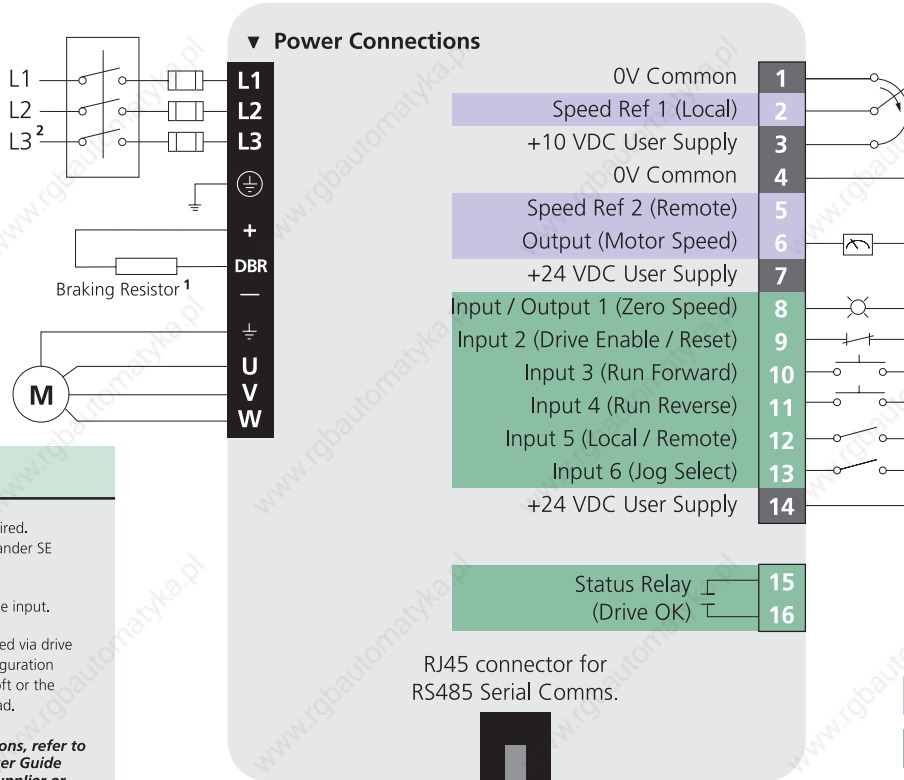

NOTE

- Thermal protection required. Not available on Commander SE Size 1.
- Not used for single-phase input.
- Some I/O may be modified via drive Keypad. Enhanced configuration may be done using SESoft or the optional Universal Keypad.

For complete instructions, refer to the Commander SE User Guide available from local supplier or www.controltechniques.com/download.htm

Terminal Diagram: Terminal Description

Commander SE

TERMINAL DESCRIPTION

Pin#	Function ①	Type/Description	Notes
1	0V Common	Common for External Analog Signals	
2	Analog Input 1 (Local Frequency / Speed Reference), 10 bit	Single-ended Analog Input	0 to +10VDC, 100k Ohms, Sample Time 6ms
3	+10VDC User Supply	Reference Supply	5 mA max Short Circuit Protected
4	0V Common	Common for External Digital Signals	
5	Analog Input 2 (Remote Frequency / Speed Reference), 10 bit	Single-ended Analog Input	4-20 mA ² input, 200 Ohms, Sample Time 6ms
6	Analog Output 1 (Frequency / Speed), 10 bit	Single-ended Analog Output, Unipolar	0 to +10VDC @ 5 mA max Update Time 22ms
7	+24VDC User Supply Short Circuit Protected	User Supply	100 mA max
8	Digital I/O 1 (Zero Speed Output)	Digital Input / Output	0 to 24VDC, 7.5k Ohms input or 0 to 24VDC, 50 mA max output Update Time 1.5ms

Pin#	Function ①	Type/Description	Notes
9	Digital Input (Enable)	Digital Input	0 to 24VDC, 7.5k Ohms Update Time 1.5ms
10	Digital Input (Run Forward)	Digital Input	0 to 24VDC, 7.5k Ohms Update Time 1.5ms
11	Digital Input (Run Reverse)	Digital Input	0 to 24VDC, 7.5k Ohms Update Time 1.5ms
12	Digital Input (Local/Remote Select)	Digital Input	0 to 24VDC, 7.5k Ohms Update Time 1.5ms
13	Digital Input (Jog Select)	Digital Input	0 to 24VDC, 7.5k Ohms Update Time 1.5ms
14	+24VDC User Supply	User Supply	100 mA max Short Circuit Protected
15	Status Relay (Drive Healthy)	Normally Open	240 VAC, 6A resistive
16	Status Relay (Drive Healthy)	Normally Open	240 VAC, 6A resistive

① Programmable Analog Programmable Digital All Analog I/O is scalable

② Values in brackets designate default functions.

③ 0-20, 20-0, and 20-4 mA are also available. See Commander SE Manual.

SPECIFICATION

Environment

Ambient Operating Temperature	-10°C to 40°C @ 6kHz. -10°C to 50°C @ 3kHz For SE Size 4 (@ 18.5kW) and all SE Size 5's. -10°C to 40°C @ 3kHz
Cooling method	Convection and forced convection, model dependent
Humidity	95% maximum non-condensing at 40°C
Storage Temperature	-40°C to 60°C
Altitude	Derate the continuous output current by 1% for every 100m above 1000m to a maximum of 4000m.
Vibration	Tested in accordance with IEC 68-2-34 and IEC 68-2-36
Mechanical Shock	Tested in accordance with IEC 68-2-29
Enclosure	NEMA 1 (IP 21)
Electromagnetic Immunity	In compliance with EN61800-3 and EN50082-2
Electromagnetic Emissions	In compliance with EN61800-3 second environment, without RFI filter: EN50081-1*, EN50082-1-2 and EN50081-3 first environment with optional RFI filter. *Size 1 only

AC Supply Requirements

Voltage	200V model: 200 to 240 VAC \pm 10% 400V model: 380 to 480 VAC \pm 10%
Phase	1ph and 3ph (Model dependent)
Maximum Supply Imbalance	2% negative phase sequence (3% voltage imbalance between phases)
Frequency	48 to 62 Hz
Input Displacement	0.97
Power Factor	

Control

Switching Frequency	3, 6 and 12 kHz (Default value model dependent)
Output Frequency	Up to 1000 Hz
Frequency Accuracy	\pm 0.01% of full scale
Frequency Resolution	0.1 Hz
Analog Input Resolution	10 Bit + sign (Qty 2)

Serial Communications ANSI 2-wire EIA485 via RJ45 connector: Baud rate is 4800, 9600 or 19,200

Braking DC injection braking standard. Dynamic braking transistor standard (not available on Size 1)

Protection

DC Bus Undervoltage Trip	200V model: 180 VDC (approx 127 VAC line voltage) 400V model: 400 VDC (approx 282 VAC line voltage)
DC Bus Overvoltage Trip	200V model: 420 VDC (approx 299 VAC line voltage) 400V model: 830 VDC (approx 587 VAC line voltage)
MOV Voltage Transient Protection	160 Joules, 1400 VDC clamping (Line to line and line to earth)

Drive Overload Trip	Current overload value is exceeded. Programmable to allow up to 150% of drive current for one minute
Instantaneous Overcurrent Trip	215% of drive rated current
Phase Loss Trip	DC bus ripple threshold exceeded
Overtemperature Trip	Drive heatsink temperature exceeds 95°C (203°F)
Short Circuit Trip	Protects against output phase to phase fault
Earth Fault Trip	Protects against output phase to earth fault
Motor Thermal Trip	Electronically protects the motor from overheating due to loading conditions

Approvals & Listings

UL, cUL	UL File Listed 8D14
IEC	Meets IEC Vibration, Mechanical Shock and Electromagnetic Immunity Standards
CE	Designed for marking
NEMA	NEMA 1 enclosure type
ISO 9002	Certified Manufacturing Facility
ISO 14001	Certified Manufacturing Facility

DIMENSIONS (mm)

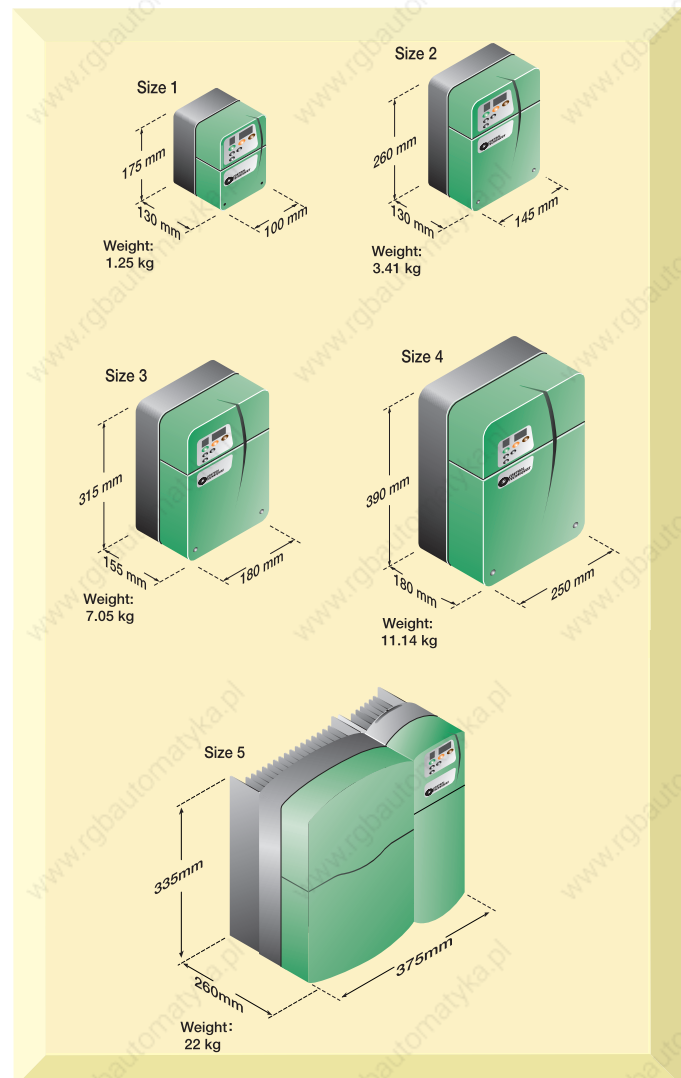

OPTIONS

Overview

This simple and easy drive also provides flexibility with easy to install options. Drive set-up is quick and convenient using our remote keypad or SESoft, the Windows based configuration tool. The SE QuickKey allows parameter cloning for fast parameter storage and transfer, making it easy to add or replace drives within your system. The Commander SE easily connects into your network with a wide range of fieldbus protocols and operator interface options.



Options At-A-Glance

Option	Description	Order Code
Drive Configuration & Programming	Configuration Tool	SESoft
	RS232/485 Cable	CTComms Cable
	QuickKey Cloning Tool	SE55
Operator Interfaces	Remote Keypad	Universal Keypad
	Operator Interface HMI	Refer to Drive Centre
Power Accessories	Cable Shield Clamps	SE11 to SE14
	EMC Filters	To fit drive
	Braking Resistors	To fit drive
Input/Output	Bi-polar Analog Input Card	SE51
Communication	RS485/Modbus RTU	Standard
	PROFIBUS-DP	SE73
	INTERBUS	SE74
	DeviceNet	SE77DN
	CANopen	SE77CO

DRIVE CONFIGURATION AND PROGRAMMING

Drive Configuration Tool

SESoft is a complimentary Windows™ based drive configuration tool designed to enable the complete control and display of all parameters within a Commander SE. The set-up wizard guides the user in entering motor and application data. Motor data may be supplied from the motor nameplate, or the user may select a motor from the database supplied in the wizard. A monitoring screen displays real-time drive values such as current, voltage and DC bus level. SESoft communicates via the computer's serial port and the Commander SE's RJ45 port using the CT Comms Cable.

SESoft IS SUPPLIED WITH THE DRIVE OR YOU CAN DOWNLOAD FROM
www.controltechniques.com/download.htm

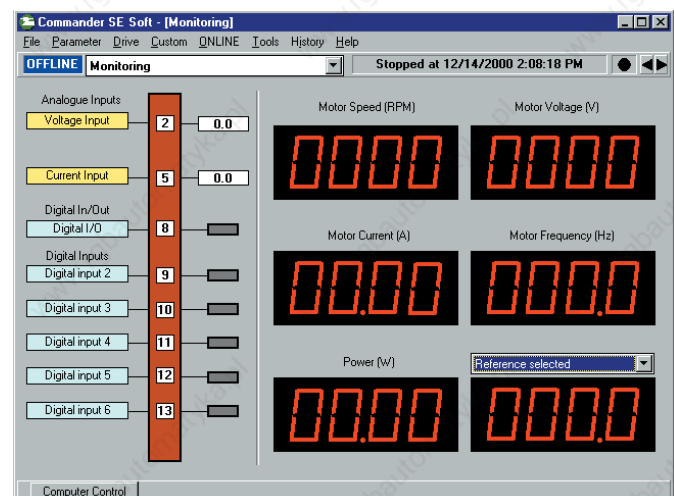
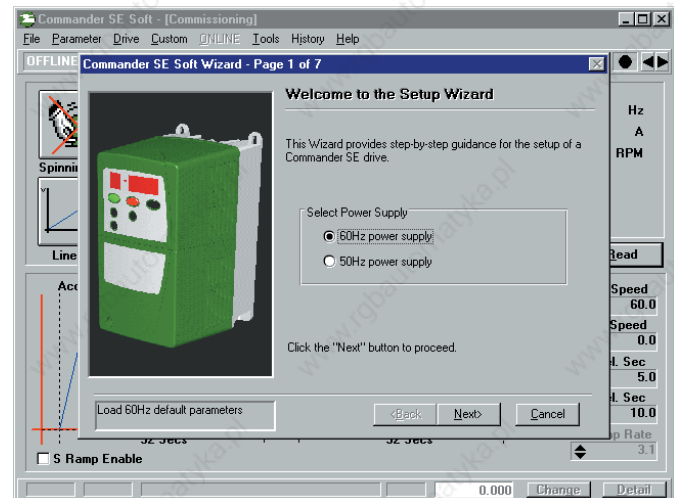

Programming / Configuration Cable

Using a special RS232 to RS485 converter you can connect the PC to the RJ45 serial port on the front of the drive. A special pre-made cable is available from Control Techniques for this purpose – this same cable is used with other Control Techniques products that use a RS485 connector – such as the Unidrive .



Description	Order Code
PC-to-drive Comms Cable	CT Comms Cable

QuicKey / Cloning Module

The QuicKey is a small, encapsulated memory module that stores the entire set of the Commander SE parameter values. It plugs onto the drive near the control terminals. The Commander SE may be programmed to download / upload a set of parameters to / from the QuicKey or to operate with or without the module installed. Once the information is stored in the QuicKey, it may be removed from the drive for future use such as cloning other drives or programming a replacement drive.



OPERATOR INTERFACES

Universal Keypad

The Universal Keypad is an ideal maintenance tool for use with Control Techniques' digital drives (Commander SE, Mentor II). Five navigation keys and plain text parameter descriptions make the Keypad easy to use for viewing and modifying drive data. The keypad is designed to be hand-held or panel mounted. The IP65 rating, screw-down terminals and stress relief for cable connections assure a rugged and robust design.



An RS485 cable with an RJ45 connector on the Commander SE cable end and dressed wires on the Keypad cable end is available.

Operator Interface Unit

The HMI operator interface units incorporate a range of features including back-lit LCD display and easy-to-use navigation keys. Using the "WYSIWYG" page editor, they can be programmed to display a variety of menus, submenus, alarms, fault conditions and other critical information. The HMIs support a range of capabilities including multiple font sizes, real time trends and graphs, scheduling and background programs. They communicate via 2 or 4-wire RS485 and, to simplify installation, some HMIs are rated to IP54 and require no screw mounting holes.



HMI 200

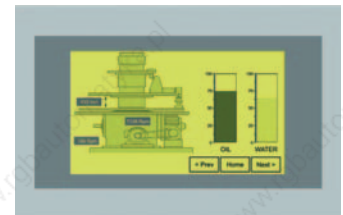

VT155W



TIU500

POWER ACCESSORIES

Cable Shield Clamps

The cable shield clamps are used with the Commander SE to stabilise wire / cable connections when mounting a drive inside an enclosure. The clamps

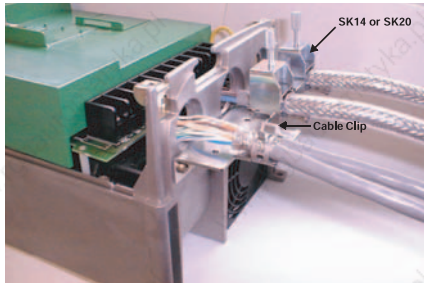

attach to the bottom of the Commander SE drive and provide a convenient shielded earth connection.

Commander SE Size	Order Code
1	SE11
2	SE12
3	SE13
4	SE14

Drive Type	EMC Filter Order Code	Filter Type	Mounting Style	Current (A)
230 VAC				
SE11200025-075	4200-6102	Standard	Footprint/Bookend	12
	4200-6101	Light Duty	Panel Mount	12
	4200-6103	Low Leakage	Footprint/Bookend	12
SE2D200075-220 Single Phase	4200-6201	Standard	Footprint/Bookend	26
	4200-6204	Light Duty	Panel Mount	26
	4200-6205	Low Leakage	Footprint/Bookend	26
SE2D200075-220 Three Phase	4200-6202	Standard	Footprint/Bookend	16
	4200-6304	Light Duty	Panel Mount	16
	4200-6207	Low Leakage	Footprint/Bookend	16
SE23200400	4200-6203	Standard	Footprint/Bookend	26
	4200-6303	Light Duty	Panel Mount	26
	4200-6209	Low Leakage	Footprint/Bookend	26
SE33200550-750	4200-6302	Standard	Footprint/Bookend	30
	4200-6303	Light Duty	Panel Mount	30
480 VAC				
SE23400075-400	4200-6202	Standard	Footprint/Bookend	16
	4200-6304	Light Duty	Panel Mount	16
	4200-6207	Low Leakage	Footprint/Bookend	16
SE33200550-750	4200-6301	Standard	Footprint/Bookend	18
	4200-6304	Light Duty	Panel Mount	18
SE43401100-1500	4200-6401	Standard	Footprint/Bookend	33
	4200-6402	Light Duty	Panel Mount	33
SE43401850	4200-6403	Standard	Footprint/Bookend	37
	4200-6404	Light Duty	Panel Mount	37
SE53402200	4200-6116	Standard	Bookend	50
SE53403000	4200-6117	Standard	Bookend	63
SE53403700	4200-6106	Standard	Bookend	100

INPUT / OUTPUT

Bi-polar Analog Input Card

The bi-polar speed reference input card (SE51) allows the direction of a motor to be controlled via a speed potentiometer or external bi-polar speed reference rather than the forward/reverse terminal selector.

The +10V potentiometer reference can be supplied from the drive (term. #3) or from an external power supply. The -10V potentiometer reference must be supplied from an external supply. The SE51 also has a relay that is controlled by the digital output (default "zero speed") of the drive.

Bi-polar Analog Input Card Terminal Diagram

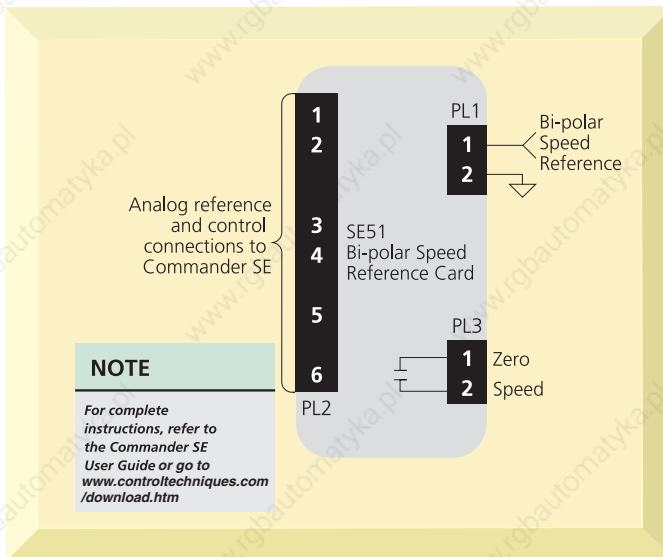

Bi-polar Analog Input Card Terminal Description

Signal Connector	Pin #	Function
PL1	1	Bi-polar Analog Input (± 10 VDC, 22k Ohms)
	2	0V Common
PL2 (Interface connections to Commander SE)	1	0V Common
	2	0 to +10VDC Analog Output
	3	+24 VDC Supply for option card
	4	Digital Input (+24 VDC) to control relay
PL3	5	Run Forward Output (+24 VDC)*
	6	Run Reverse or Run Forward / Reverse Output (+24 VDC)*
PL3	1	Relay Contact Common (48 VAC / DC, 2A resistive)
	2	Relay Contact (Normally Open)

* Directional control of Commander SE

COMMUNICATION

Communication Cards



Each fieldbus interface for the Commander SE is a single option card that fits within the drive. Parameter data is transferred to and from the Commander SE using a 2-wire RS485 link into the serial communications port on the drive.

Communication Protocol*	Order Code
RS485 / Modbus RTU	as standard
PROFIBUS-DP	SE73
INTERBUS	SE74
DeviceNet	SE77DN
CANopen	SE77CO

* Maximum communication rate through RJ45 port is 19.2 kbaud. Commander SE operates as slave node only.



Commander SX

OVERVIEW

Dirt, dust, water, pollution. All environments that can mean additional cost whenever a variable speed drive is needed. From wash down food and drink applications to dust and other airborne particles such as in a textile plant, Control Techniques have designed the perfect match for such rugged applications – Commander SX

The Commander SX from 0.37kW to 7.5kW is an IP66 (NEMA 4X) protected drive that enables users to mount the drive directly next to the motor giving significant cabling, cabinet and installation savings. The practicality of mounting the drive near the motor, while being protected from the harsh environments, brings users the additional benefit over integrated motors by separating the two technologies in the event of maintenance and breakdown. Typical applications include; Fans, Pumps, Conveyors, Blowers, Ovens and Chillers.

- 0.37 to 4kW 3 phase 200VAC
- 0.75 to 7.5kW 3 phase 400VAC
- IP66 NEMA 4X enclosed drive – no need for separate enclosure
- Designed for 'direct to wall' or next to motor mounting – avoiding cabling, cabinet, and installation costs
- Easy set up and commissioning – the first ten parameters cover 80% of applications
- More than 8 preset drive configurations
- Surface textured and rounded corners designed to maximise washdown effectiveness
- Internally fitted EMC filter (to generic and drive standards) for units up to 4kW, with externally fitting IP66 filters above 4kW
- Robust industrial housing with simple speed control interface



TYPICAL APPLICATIONS

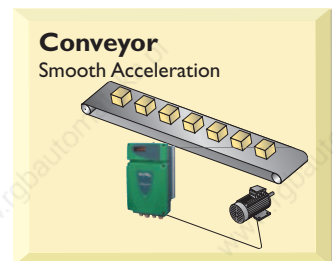
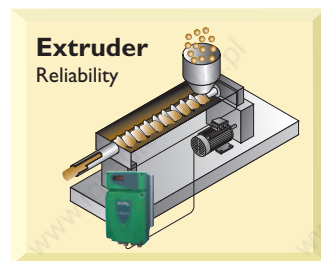
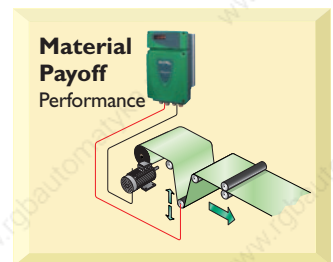
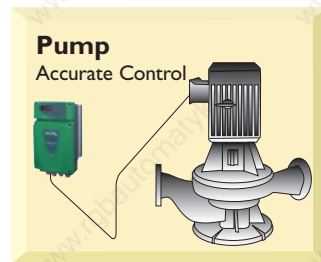

FEATURE PERFORMANCE

- Open loop vector control with true space vector modulation – Precise control algorithm provides full torque down to 1 Hz for exceptional performance
- Access to multiple parameter levels – Customises the drive to meet each user's needs: simple (level 1), flexible (level 2) and advanced (level 3)
- XpressKey cloning module – Provides fast and cost-effective drive-to-drive parameter transfer and storage with no PC required
- Static auto-tune – Allows fast motor / drive optimisation without motor shaft rotation
- Configurable analog and digital I/O – Customises drive to the specific application
- S-ramp accel / decel profiling – Provides smooth speed transitions, minimising machine "jerk"
- Built-in independent PID control – Eliminates the need for an external PID controller while providing "outer loop" control of a process variable
- Built-in Motorised Potentiometer – Emulates the functionality of the traditional motorised potentiometer with increase/decrease pushbuttons.
- 8 Preset speeds with independent accel / decel ramps – Allows predetermined speed sequencing via logic inputs
- Selectable Stopping modes including Ramp, Coast, DC – Injection, and Dynamic Braking – Added flexibility meets many application requirements
- Full EMC compliance with optional filter – Meets global standards for worldwide use



PB Local Controls and access to basic parameters via buttons.



PT Local Controls via buttons and potentiometer. Access to parameters via LCD console or PC.



DV Display only. Access to parameters via LCD console or PC.

RATINGS

200 to 220 VAC 3 phase \pm 10%

Order Code	Frame size	Input Phases	kW	100% output current (A)	150% overload current for 60s
SX13200037	1	3	0.37	2.5	3.8
SX13200055	1	3	0.55	3.2	4.8
SX13200075	1	3	0.75	4.5	6.8
SX23200110	2	3	1.1	6	9
SX23200150	2	3	1.5	8	12
SX23200220	2	3	2.2	10	15
SX33200300	3	3	3	13.5	20
SX33200400	3	3	4	16.5	25

380 to 480 VAC 3 phase \pm 10%

Order Code	Frame size	Input Phases	kW	100% output current (A)	150% overload current for 60s
SX13400075	1	3	0.75	2.5	3.8
SX13400110	1	3	1.1	3.2	4.8
SX13400150	1	3	1.5	4.5	6.8
SX23400220	2	3	2.2	6	9
SX23400300	2	3	3	8	12
SX23400400	2	3	4	10	15
SX33400550	3	3	5.5	13.5	20
SX33400750	3	3	7.5	16.5	25

Product Designation

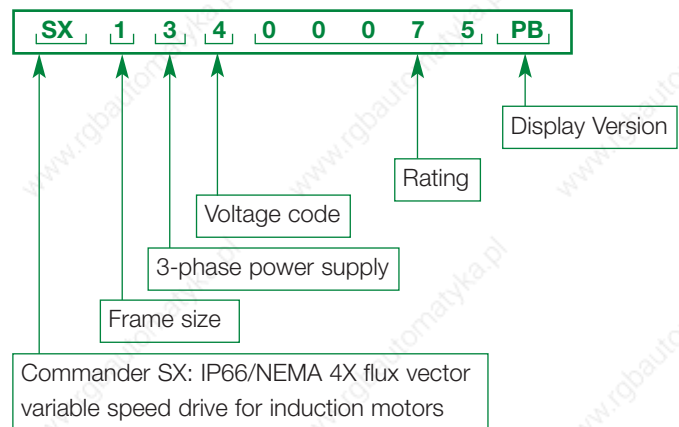

- PB: Local controls and access to basic parameters via buttons.
- PT: Local controls via buttons and potentiometer. Access to parameters via PX-LCD console or PC.
- DV: Display only. Access to parameters via PX-LCD console or PC.

TERMINAL DIAGRAM

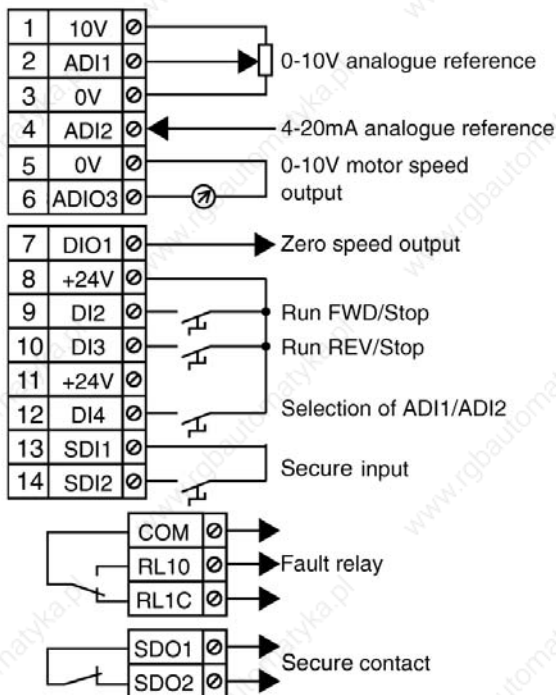
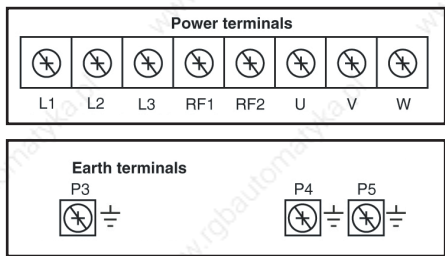

Applying secure input SDI2 to obtain a secure stop

The Secure Input function provides a means for preventing the drive from generating torque in the motor, with a very high level of integrity. It is suitable for incorporation into a safety system for a machine. It is also suitable for use as a conventional drive enable input.

The Secure Input function is fail-safe, so when the input is disconnected the drive will not operate the motor, even if a combination of components within the drive has failed. Most component failures are revealed by the drive failing to operate. Secure Input is also independent of the drive firmware. This meets the requirements of EN954-1 category 3 for the prevention of operation of the motor when the PX-Secure option module is used.

Secure Input can be used to eliminate the need for electro-mechanical contactors, including special safety contactors, which would otherwise be required for safety applications.

Connections in accordance with safety standard EN954-1 – category 2 or 3

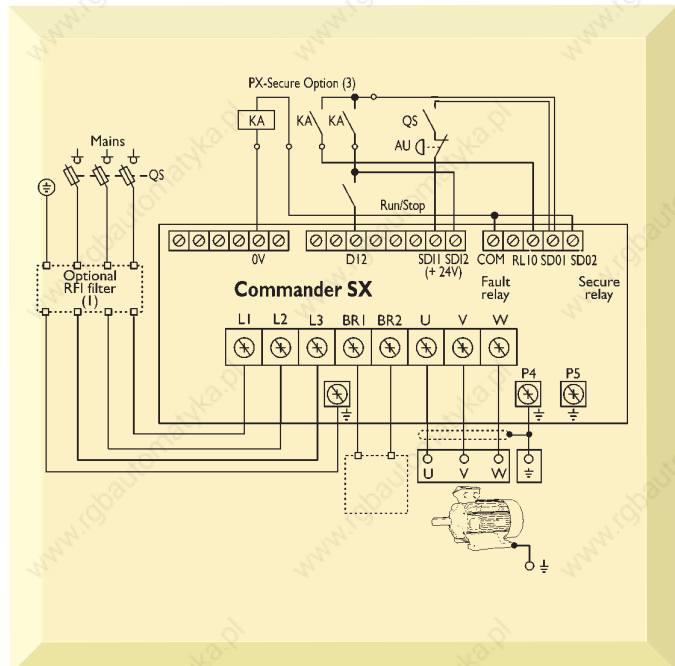

TERMINAL DESCRIPTION

1	10V	+10V internal analog source
	Accuracy	$\pm 2\%$
	Maximum output current	20 mA
	Protection	Threshold at 15V

2	AD11	Analog or logic input 1
	Resolution	10 bits
	Sampling	6 ms
Voltage input		
	Full scale voltage range	$10V \pm 2\%$
	Maximum voltage	33V
	Input impedance	95 k
Current input		
	Current ranges	0 to 20 mA $\pm 5\%$
	Maximum voltage	33V/0V
	Maximum current	33 mA
	Input impedance	500
Logic input (if connected to the +24V)		
	Thresholds	0: < 5V 1: > 10V
	Voltage range	0 to +24V
	Maximum voltage	33V/0V
	Load	95 k
	Input threshold	7.5V

3	0V	Logic circuit common 0V
----------	-----------	--------------------------------

4	AD12	Analog or logic input 2
	Resolution	10 bits
	Sampling	6 ms
Voltage input		
	Full scale voltage range	$10V \pm 2\%$
	Maximum voltage	33V
	Input impedance	95 k
Current input		
	Current ranges	0 to 20 mA $\pm 5\%$
	Maximum voltage	33V/0V
	Maximum current	33 mA
	Input impedance	500
Logic input (if connected to the +24V)		
	Thresholds	0: < 5V 1: > 10V
	Voltage range	0 to +24V
	Maximum voltage	33V/0V
	Load	95 k
	Input threshold	7.5V
PTC Sensor input		
	Internal Voltage	5V
	Default threshold	> 3.3k
	Reset default threshold	< 1.8k

6	ADIO3	Analog or logic input or analog output 3
	Characteristics	Unipolar analog voltage (common mode) or current
	Resolution	10 bits
	Sampling	6 ms
Voltage input		
	Full scale voltage range	$10V \pm 2\%$
	Maximum voltage	33V
	Input impedance	95 k
Current input		
	Current ranges	0 to 20 mA $\pm 5\%$
	Maximum voltage	33V
	Maximum current	33 mA
	Input impedance	500
Logic input (if connected to the +24V)		
	Thresholds	0: < 5V 1: > 10V
	Voltage range	0 to +24V
	Maximum voltage	33V/0V
	Load	95 k
	Input threshold	7.5V
Voltage output		
	Voltage range	0 to 10V
	Load resistor	2 k
	Protection	Short-circuit (40 mA max)
Current output		
	Current range	0 to 20 mA
	Maximum voltage	10V
	Maximum load resistor	1 k

7	DIO1	Logic input or output 1
	Characteristics	Logic input or output (positive logic)
	Thresholds	0: < 5V 1: > 10V
	Voltage range	0 to +24V
	Sampling/refreshment	2 ms
Logic input		
	Maximum voltage	-0V to +35V
	Load	15 k
	Input threshold	7.5V
Logic output		
	Maximum output current	50 mA
	Overload current	50 mA

8	+24V	+24V internal source
11		
Output current		100 mA in total
Overload current		150 mA
Accuracy		± 5%
Protection		Current limiting and setting to fault mode

9	DI2	Logic input 2
10	DI3	Logic input 3
12	DI4	Logic input 4
Characteristics		Logic input (positive logic)
Thresholds		0: < 5V 1: > 10V
Voltage range		0 to +24V
Sampling/refreshment		2 ms
Maximum voltage		0V or +35V
Load		15 k
Input threshold		7.5V

13	SDI1	+24V DC dedicated to secure input only
14	SDI2	secure input/enable
Characteristics		Logic input (positive logic)
Thresholds		0: < 5V 1: > 18V
Voltage range		9V to 33V
Impedance		820

15	COM	Fault relay output
16	RLIC	
17	RLIO	
Characteristics		NO_NC single-pole changeover contact 250VAC
Maximum contact current		<ul style="list-style-type: none"> • 2A, resistive load • 2A, inductive load

18	SDO1	Secure contact
19	SDO2	
Characteristics		250 VAC
Maximum contact current		<ul style="list-style-type: none"> • 2A, resistive load • 1A, inductive load

SPECIFICATION

Environment

IP66 Nema 4X rating for mounting in close proximity to the motor and application.

Ambient temperature 40°C (104°F) without derating. Up to 50°C operation with a maximum derating of only one motor size.

Removable gland plate for easy termination and removal of control and motor cables.

Complies with EN954-1 Cat 3 with PX-Secure option.

EMC cable gland option for shielded cable management.

Electromagnetic Immunity complies with EN61800-3 (Drive standard) and EN61000-6-2 (generic standard).

Electromagnetic Emissions complies with EN61800-3 (Drive standard - 1st and 2nd environment) with integral EMC filter.

Complies with EN61000-6-3 and EN61000-6-4 (Generic standard) with integral EMC filter.

Earth leakage current less than 3mA with integral EMC filter in circuit.

European Hygienic Engineering and Design Group EHEDG and FDA hygienic recommendations have been adopted for the food industry:

- No paint.
- Anodised aluminium heat sink.
- Polycarbonate covers.
- All slopes > 3 degrees incline.
- Roughness < 0.8 microns.
- No zones where liquids can accumulate.

Control

Open loop vector control.

V/F control.

Closed loop vector with PX-Encoder option.

Speed reference input 0-10V, 0-20mA, 4-20mA.

Digital inputs: Enable, Run forward, Run reverse, Jog, local/remote select.

Switching frequency 3kHz to 11kHz with 4.5kHz as default.

Acceleration and Deceleration ramps (linear and S-type).

Serial communication as standard

- Modbus RTU RS485 via RJ45 connector.

DC injection braking as standard.

Integral dynamic braking transistor and resistor. PID Controller.

Protection

Undervoltage, Supply and DC Link overvoltage, Phase loss, Drive overload, Instantaneous overcurrent, Over temp, Short circuit, Ground fault, Over heat, Motor thermal, Watchdog.

DIMENSIONS (mm)

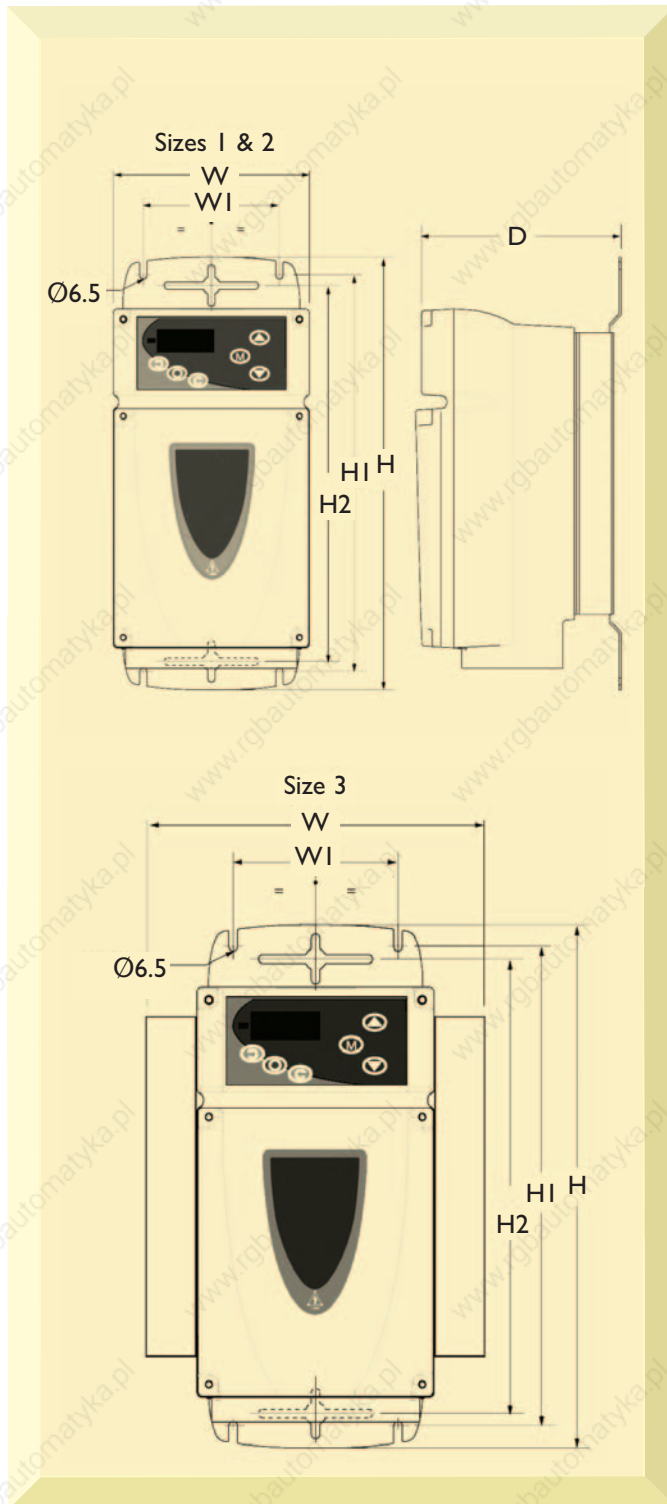

Commander SX		Dimensions (mm)					Screw	Weight kg
Size	W	WI	H	HI	H2	D		
1	180	125	380	350	330	189	M6	4.7
2	180	125	380	350	330	223	M6	6.7
3	281	125	380	350	330	233	M6	8.8

OPTIONS

Options At-A-Glance

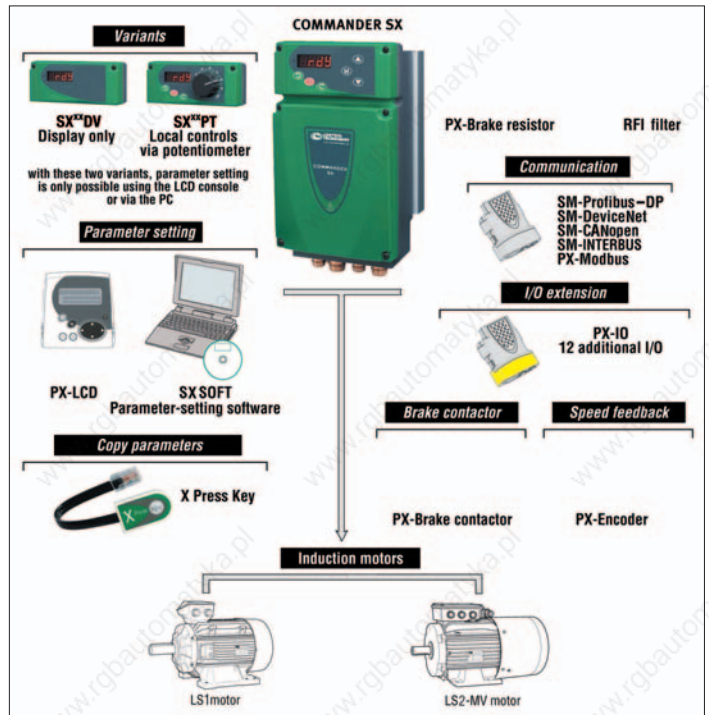

Option	Description	Order Code
Drive Configuration and Programming	LCD hand held programmer	PX-LCD
	Commissioning software	SXSoft
	PC to drive comms cable	CT Comms Cable
	Cloning and parameter copying	Xpresskey
Operator Interface	Display only	SX ^{DV}
	Local Controls via potenhometer	SX ^{PT}
Power Accessories	Brake resistor	Drive dependant
	EMC filter IP66	Drive dependant
Input/ Output	12 additional I/O	PX-I/O
Motor Feedback	Encoder feedback	PX-Encoder
Communications	Modbus RTU	Standard
	PROFIBUS-DP	SM-PROFIBUS-DP
	DeviceNet	SM-DeviceNet
	CANopen	SM-CANopen
	INTERBUS	SM-INTERBUS

DRIVE CONFIGURATION AND PROGRAMMING

PX-LCD

This handheld console makes it much easier to set the Commander SX parameters and access them. Its LCD display, consisting of one line of 12 characters and 2 lines of 16 characters, offers text which can be displayed in 5 languages (English, French, German, Italian and Spanish).

The PX-LCD console has 4 main functions:

- A read mode for Commander SX supervision and diagnostics
- From the time it is plugged in, the PX-LCD display is in read mode. By pressing the keys, the user can scroll through all the parameters required for supervision and diagnostics, such as:
 - motor current
 - motor frequency
 - motor voltage
 - analogue I/O levels
 - logic I/O states
 - logic function states
 - timer
 - last faults
- An interactive parameter-setting wizard which makes it very simple to configure the Commander SX. The parameters are set in successive steps. The parameters offered at each step by the PX-LCD handheld console depend on parameters set in the previous steps. The user will therefore only be offered those parameters required by the application
- Access to all the Commander SX advanced parameters in order to optimise settings or configure special applications. All the parameters, organised by menus, can be accessed via the PX-LCD console



This kit enables user-friendly parameter setting or supervision of the Commander SX and offers numerous functions:

- Interactive parameter-setting wizard
- Leroy-Somer motor database
- File saving
- Online help
- Comparison of 2 files or one file with the factory setting
- Printing of a complete file or differences compared to the Factory setting
- Supervision
- Diagnostics
- Representation of parameters in table or graphic form

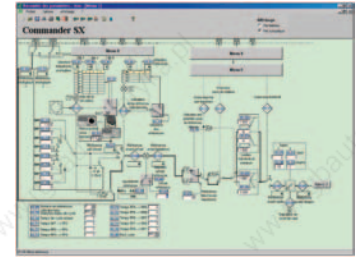

SXSoft CAN BE DOWNLOADED FROM
www.controltechniques.com/download.htm

Programming / Configuration Cable

Using a special RS232 to RS485 converter you can connect the PC to the RJ45 serial port on the front of the drive. A special pre-made cable is available from Control Techniques for this purpose – this same cable is used with other Control Techniques products that use a RJ45 RS485 connector such as the Unidrive  and Commander SK.



Description	Order Code
PC-to-drive Comms Cable	CT Comms Cable

XPressKey



The XPressKey option is used to save a copy of all the Commander SX parameters so that they can be duplicated very simply into another drive.

To Save parameters using the XPressKey:

- Connect the XPressKey to the Commander SX serial port
- With the drive disabled "Inh", set Pr 64 to "Prog"
- Confirm the transfer of parameters into XPressKey by pressing the drive "Stop" key

To set the drive parameters with the XPressKey:

- Connect the XPressKey to the serial port
- With the drive disabled "Inh", press the "Key" button once
- Confirm the transfer of parameters into the drive by pressing the "Key" button a second time
- When the display reverts back to "Inh", the transfer is complete and the XPressKey can be disconnected and replaced in its storage slot

OPERATOR INTERFACE

Local Controls via pushbutton (PB)

Commander SX is supplied as standard with LED display comprising 4 x 7 segment digits to indicate drive status and operating data. Programming is done via intuitive operator panel with 3 control buttons and three parameter setting buttons. All parameters are in a simple menu structure and programming is done in a simple and easy way just like Commander SK.



Local controls via Potentiometer (PT)

This version is available to give local speed setting via a rugged potentiometer. All parameter adjustments during set up need to be done using either the PX-LCD console or via the PC and SXSoft.



Display only (DV)

Designed for special OEM applications where regular interfacing with Commander SX is not required. This version ensures no unwanted user interference during operation.



POWER ACCESSORIES

EMC filter

Commander SX sizes 1 and 2 drives conform to the drive standard EN 61800-3 since they have an RFI filter integrated internally, as standard.

For conformity of size 3 Commander SX drives and in certain conditions for sizes 1 and 2, an external RFI filter must be added (part number FS 6376-16-07).

The customer connects the filter to the mains supply, without any special tools, using an IP 66 dust and damp proof insulation displacement connector.

For Commander SX sizes 1 and 2, the filter should be mounted on the left as close as possible to the drive.

For size 3, the filter should be mounted on the heatsink.

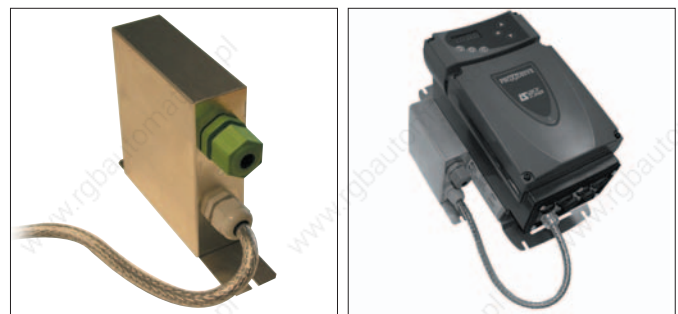

Description	Order Code
IP66 RF Filter	FS6376-16-07

PX-Brake resistor

The braking resistors are supplied on a metal plate ready to be fixed using 4 screws at the back of the drive.

To ensure that the heat losses from the resistors are dissipated correctly, the drive must be fixed with spacers (supplied with the resistors).

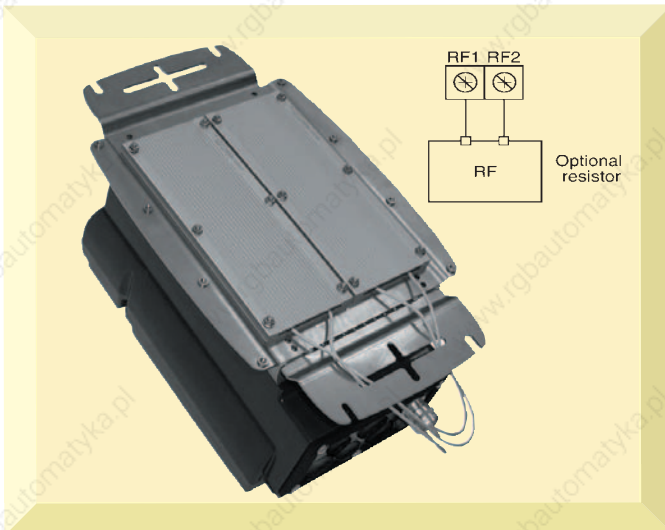

Electrical characteristics

Minimum compatible resistance

Commander SX	Minimum value Ω	Order Code
Sizes 1 and 2	180	Consult Sales Office
Size 3	60	Consult Sales Office

INPUT/OUTPUT

PX-I/O Plus

This module enables the drive system designer to solve more complex applications by providing additional inputs and outputs that the Commander SX can access locally. These connections on 12-pin and 3-pin removable terminal strips are programmable using SXSofT or the drive's keypad. Their assignments are stored within the drive's memory.

PX-I/O Terminal Description

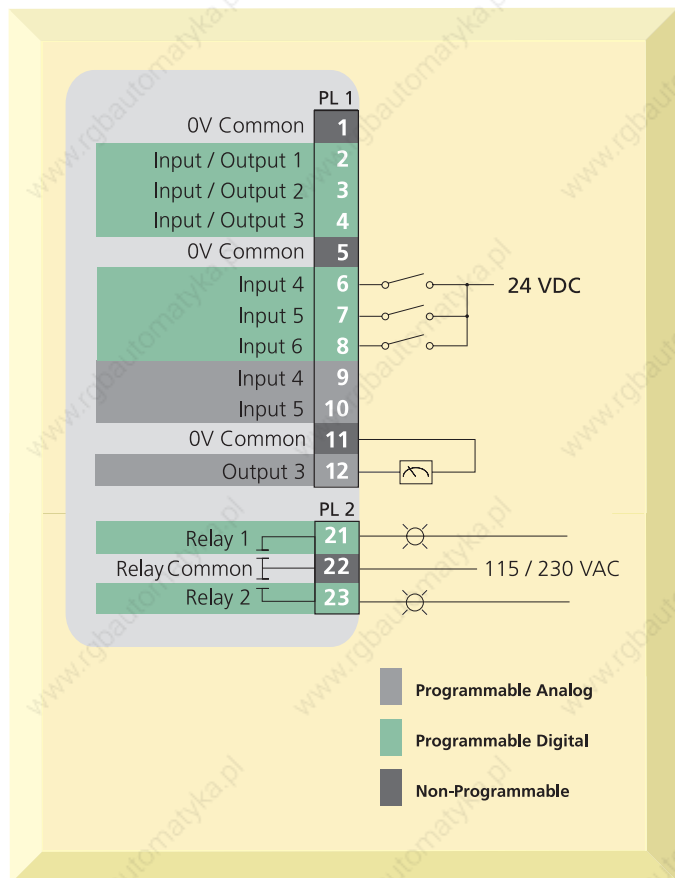

PX-I/O Terminal Description

Quantity	Description	Notes
2	Relay Contacts (N.O.)	110 VAC, 2 A resistive
3	Digital Input	+24 VDC, 7.5k Ohms
3	Digital Input / Output	+24 VDC, 7.5k Ohms / +24 VDC @ 10 mA max.
2	Analog Voltage Input	± 10 VDC, 20k Ohms, 10 bit
1	Analog Voltage Output	± 10 VDC @ 30 mA max., 10 bit

MOTOR FEEDBACK

PX-Encoder

The PX-Encoder module provides an internally fitted encoder feedback option up to 32,000 lines per revolution.



COMMUNICATIONS

Fieldbus Network

Communication Modules

The Commander SX has a standard Modbus RTU RS485 communications RJ45 connector. In addition, SM fieldbus option modules can be inserted to control and monitor a Commander SX on fieldbus networks. The standard Modbus-RTU port can be used for drive configuration using SXSoft.



SM-DeviceNet
DeviceNet
CONFORMANCE TESTED



SM-PROFIBUS-DP
PROFIBUS



SM-CANopen
CANopen



SM-INTERBUS
INTERBUS
Certified! No. 197



Communications Protocol	Interface Order Code
PROFIBUS-DP	SM-PROFIBUS DP
INTERBUS	SM-INTERBUS
DeviceNet	SM-DeviceNet
CANopen	SM-CANopen
MODBUS	Standard

Unidrive Integration flexibility with

Overview

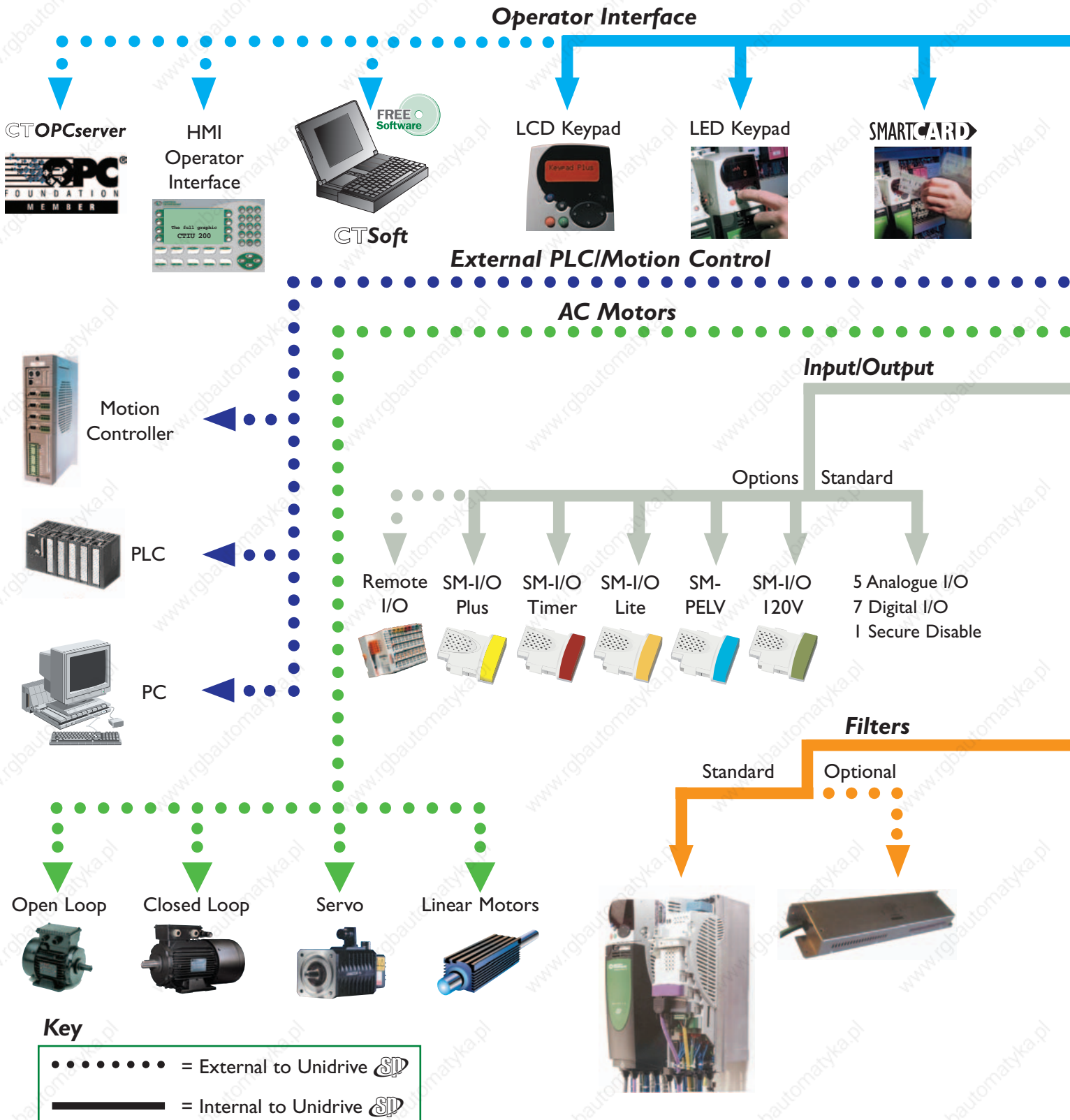

Unidrive Overview

Unidrive - the Solutions Platform



Applications with PLC or Motion functionality

SM-Applications Lite OR SM-Applications OR SM-EZMotion



Programming Platform



OR SyPTPro (IEC61131-3)

Programming Platform -
Power ToolsPro
Motion Made Easy

Indexing
Gearing
Profiles

Feedback

PLC Functionality

Features
Function Block Programming
Ladder Logic Sequencing

AND

Motion Functionality

Features
Embedded Position Loop
Function Block Programming
Ladder Logic Sequencing

Standard

SinCos
Quadrature
Frequency/Direction
Clockwise/
Counter clockwise



Communications

Standard

Options



Modbus RTU



CAN Interface DeviceNet

Ethernet TCP/IP



Unidrive

OVERVIEW

The Unidrive is "The Benchmark" for AC drive and servo controls in the automation industry. It is a truly scalable "Solutions Platform" with the flexibility to be personalised to customers requirements, and lower true total cost while maximizing productivity.

The Unidrive "Solution Platform" incorporates many cost saving and performance improvement features based on input from end users and OEMs. These include Secure Disable, Multiple Fieldbus capability, on-board EMC filter, Universal feedback device support, and the facility for up to three Solution Modules to tailor the drive to specific application needs. Normal and Heavy-Duty operation and servo performance make the Unidrive the ideal "Solutions Platform."

SOLUTIONS PLATFORM



Typical Applications

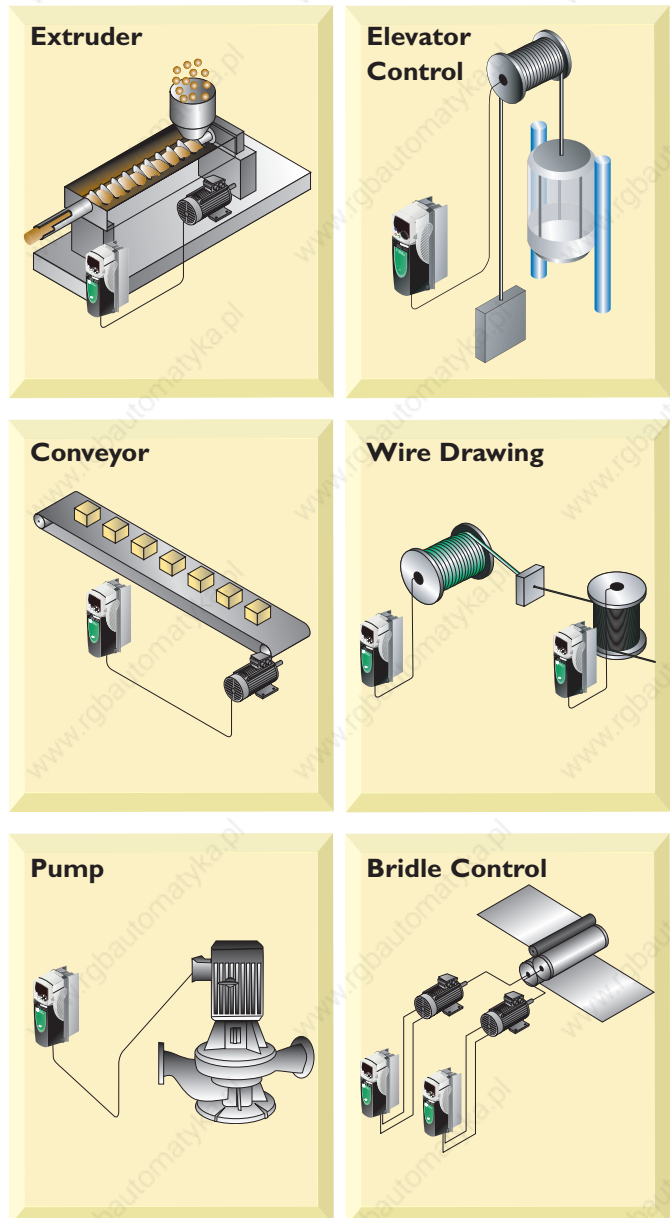

- **Universal Digital AC Drive**
- **0.75 to 30kW, 3 phase, 200-240 VAC**
- **0.75 to 1200kW, 3 phase, 380-480 VAC**
- **2.2 to 1000kW, 3 phase, 575 VAC**
- **15 to 1200kW, 3 phase, 690 VAC**
- **Five operating modes with energy-saving Power Factor Control in Regen Mode***
- **Secure Disable for contactor elimination to EN954-1 cat 3**
- **SMARTCARD – Parameter and application program cloning and back up card**
- **Universal feedback interface with 12 selectable modes**
- **High Resolution Analog Input (16 bit plus sign)**
- **RS485 Interface for PC connection**
- **Dual duty ratings: Normal and Heavy**
- **Three zero-space universal option slots**

*Note: Additional components are necessary to produce a regen drive package.



Size 1 – 5

Size 6 – 9



Submitted for UL listing

FEATURE PERFORMANCE

Secure Disable

The Unidrive **SD** Secure Disable function meets the requirements of EN954-1 : category 3 for machine safety, and can serve as a part of a category 4 application. Control Techniques' Secure Disable safety solution has been independently verified by the German safety organization, BIA. This exclusive feature of the Unidrive **SD** saves money and space. Under many conditions, this standard feature eliminates the need for safety contactors by utilising secure circuitry to prevent the motor shaft from being driven by the drive.

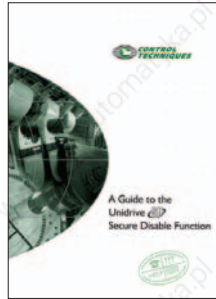

Order Code: 0175-0317

Secure Disable

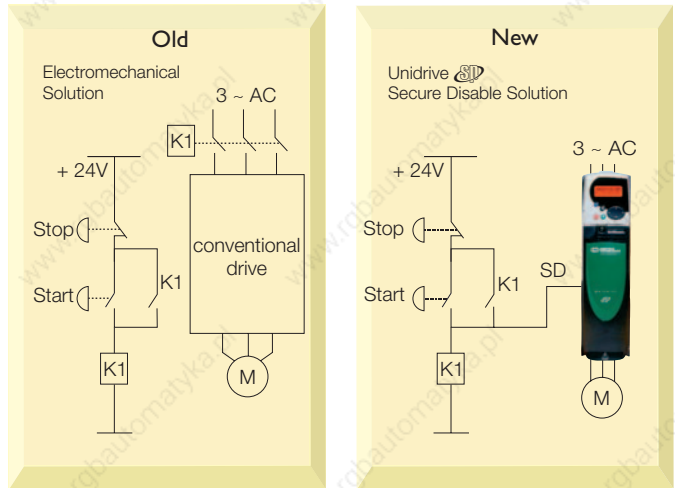

Multiple Fieldbus Capability

The Unidrive **SD** provides unrivaled fieldbus flexibility. In addition to the standard Modbus RTU port, up to three fieldbus option modules can be installed in the Unidrive **SD**'s option slots. This provides the capability to control and monitor a Unidrive **SD** on multiple fieldbus networks. For example, a single Unidrive **SD** can be configured to communicate on both DeviceNet and PROFIBUS networks simultaneously.

In the example shown, CTNet is used to provide real-time coordination between two Unidrive **SD** modules. The DeviceNet and PROFIBUS connections allow data to be passed to the controllers in a machine line.

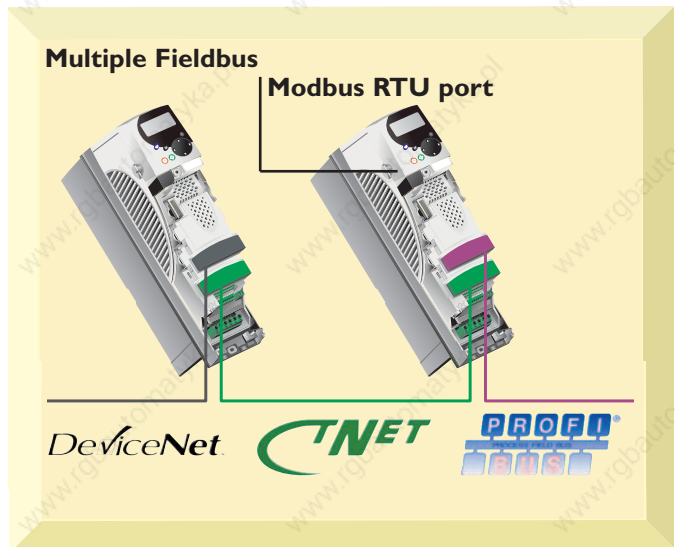

PLC Functionality with Unidrive **SD**

In addition to the extensive drive configuration capabilities of the Unidrive **SD**, scalable programming is available to solve virtually any application requirements. Simple logic function programming is achieved using **SyPTLite** software and the drive's built in PLC. More complex systems can be solved by adding SM-Applications Lite (with **SyPTLite** or **SyPTPro**) and SM-Applications (**SyPTPro** only) option modules.



SM-Applications



SM-Applications Lite

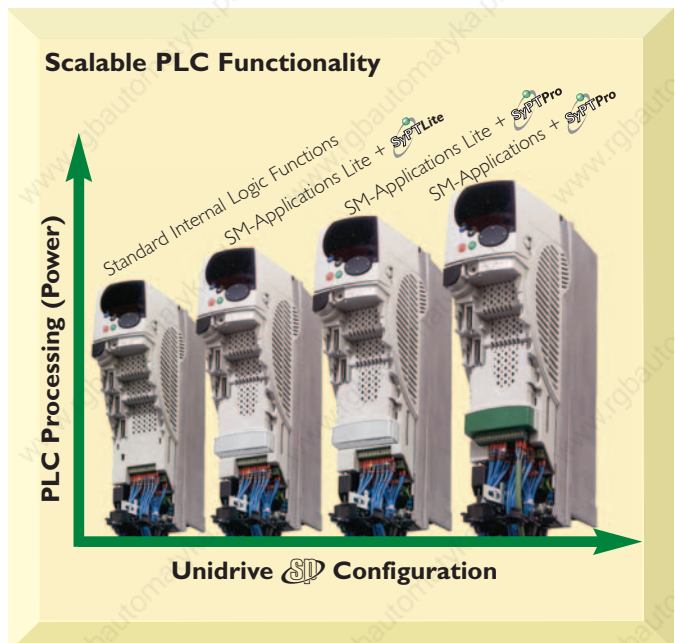

Unidrive

**THE
BENCHMARK**

FEATURE PERFORMANCE

Dual Duty Ratings – Normal and Heavy

Provides cost effective sizing choices for all applications.

Low Voltage DC Operation

Ideally suited for elevator rescue and machine tool set up.

24V DC Auxiliary Power Supply Input

Provides an additional means of maintaining control, fieldbus and position loop on mains loss.

Comprehensive Autotune

Inertia measurement and static autotune reduce startup time.

Universal Feedback Interface

Supports 12 different feedback configurations, including several absolute encoders. No need for additional components.

High Resolution Analog Input

16-bit, 250 μ sec (sample time) interface for high performance applications.

Extensive Fieldbus Connectivity

ModbusRTU (Standard), PROFIBUS-DP (12Mbit), DeviceNet, CANopen, INTERBUS, CAN interface, SERCOS, Ethernet and CTNet options via zero-space SM modules.

Up to three fieldbuses can connect to a single drive, eliminating the need for expensive gateways.

Three Universal Option Slots

Fieldbus, control and application SM modules fit in any of the three option slots beneath the drive cover.

Secure Disable Function

Conforms to EN954-1 Category 3 for machine safety with system cost reduction.

SMART for Simple Setup, Cloning and Back-up

Easy-to-use card stores drive configuration and application program for simple startup and parameter cloning. Supplied free with Unidrive 

Keypad Options

Choose between no keypad, high visibility LED keypad or multi-language LCD keypad based on the system design and operating environment.

Drive Mounted Brake Resistor

Unidrive  sizes 1 and 2 feature a drive mounted brake resistor option to reduce panel space requirements.

Standard Features of the Unidrive

- 5 Operating modes: V/Hz, open loop vector, closed loop vector, servo, and regen
- 32-bit application co-processor module (up to a maximum of 3 modules)
- Universal encoder feedback
- Application functions for Torque control, Brake control and Axis-limit control
- Built-in shaft orientation mode
- Digital lock with adjustable ratio (frequency slaving)
- Programmable boolean logic (AND, NAND, OR, NOR) gates with delay outputs
- Programmable threshold comparators
- Built-in PID controller
- S-ramp accel / decel profiling
- Built-in motorised potentiometer
- 8 Preset speeds and independent accel / decel rates
- 3 Skip frequencies with adjustable bandwidths
- Run time chronometers
- Configurable analog and digital I/O
- Selectable stopping modes including Coast, Ramp, and DC injection
- Dynamic braking capability
- Removable control terminals common to all sizes
- Output frequencies up to 3000 Hz
- Intelligent Thermal Management (ITM) technology with switching frequencies up to 16 kHz

RATINGS – select model on actual motor full load current

Unidrive		Motor Output	Continuous Output Current	Peak Output Current	Motor Output	Continuous Output Current	Peak Output Current
200 / 240 VAC +/- 10% 3 phase		Normal Duty			Heavy Duty		
Order Code	Frame	kW@220V	I _N (A)	I _{PK} (A)	kW@220V	I _H (A)	I _{PK} (A)
SP1201	1	1.1	5.2	5.7	0.75	4.3	7.5
SP1202		1.5	6.8	7.5	1.1	5.8	10.2
SP1203		2.2	9.6	10.6	1.5	7.5	13.1
SP1204		3	11	12.1	2.2	10.6	18.6
SP2201	2	4	15.5	17.1	3	12.6	22.1
SP2202		5.5	22	24.2	4	17	29.8
SP2203		7.5	28	30.8	5.5	25	43.8
SP3201	3	11	42	46.2	7.5	31	54.3
SP3202		15	54	59.4	11	42	73.5
SP4201	4	18.5	68	75	15	56	98
SP4202		22	80	88	18.5	68	119
SP4203		30	104	114	22	80	140

380 / 480 VAC +/- 10% 3 phase		Normal Duty			Heavy Duty		
Order Code	Frame	kW@400V	I _N (A)	I _{PK} (A)	kW@400V	I _H (A)	I _{PK} (A)
SP1401	1	1.1	2.8	3.1	0.75	2.1	3.7
SP1402		1.5	3.8	4.2	1.1	3.0	5.3
SP1403		2.2	5	5.5	1.5	4.2	7.4
SP1404		3	6.9	7.6	2.2	5.8	10.2
SP1405		4	8.8	9.7	3	7.6	13.3
SP1406		5.5	11	12.1	4	9.5	16.6
SP2401	2	7.5	15.3	16.8	5.5	13	22.8
SP2402		11	21	23.1	7.5	16.5	28.9
SP2403		15	29	31.9	11	25	40.2
SP2404		15	29	31.9	15	29	45.5
SP3401	3	18.5	35	38.5	15	32	56
SP3402		22	43	47.3	18.5	40	70
SP3403		30	56	61.6	22	46	80.5
SP4401	4	37	68	75	30	60	105
SP4402		45	83	91	37	74	130
SP4403		55	104	114	45	96	168
SP5401	5	75	138	152	55	124	217
SP5402		90	168	185	75	156	273
SP6401	6	110	202	222	90	180	270
SP6402		132	236	260	110	210	315
SP6411		110	202	222	90	180	270
SP6412		132	236	260	110	210	315
SP7411	7	160	290	319	132	240	360
SP7412		200	350	385	160	290	435
SP8411	8	250	440	486	200	350	525
SP8412		315	540	594	250	440	660
SP8413		355	620	682	315	540	810
SP9411	9	400	700	770	355	620	930
SP9412		450	770	926	400	700	1050
SP9413		500	850	1023	450	770	1155
SP9414		560	990	1179	500	850	1275
SP9415		675 ^②	1150	1377	560	990	1485

- ① Motor kW based on four pole, 220 / 400 VAC typical motor ratings. Select model based on actual motor full load current.
- ② For ratings to 1.2MW consult your local Drive Centre.

Unidrive Product Line
 – Solution Platform
 – Size 1 to 9 complete inverter drive

Standard Power Range

Voltage Rating
 2 – 200V to 240V
 4 – 380V to 480V
 5 – 500V to 575V
 6 – 500V to 690V

Configuration
 0 – Wall Mount
 1 – Free Standing
 2 – Wall Mount, no dynamic brake control
 3 – Free Standing, no dynamic brake control
 4 – Regen Free Standing (4 Quadrant)

Normal Duty (open loop)	Suitable for most applications, current overload is set at 110% for 60 seconds. Where motor rated current is less than the drive rated continuous current, higher overloads are achieved.
Heavy Duty (open loop vector; closed)	Suitable for demanding applications, current overload is set at up to 175% for 40 seconds. Where motor rated or loop servo current is less than the drive rated continuous current, higher overloads (200% or greater) are achieved.

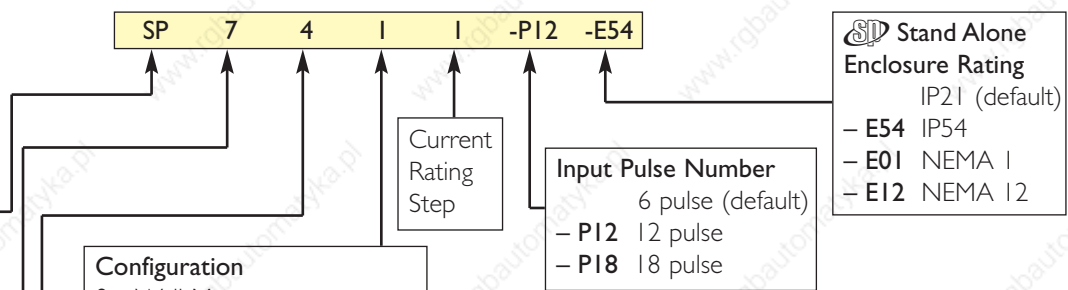

Stand Alone Enclosure Rating
 IP21 (default)
 – E54 IP54
 – E01 NEMA 1
 – E12 NEMA 12

Input Pulse Number
 6 pulse (default)
 – P12 12 pulse
 – P18 18 pulse

Current Rating Step

RATINGS – select model on actual motor full load current

Unidrive SD [®]		Motor Output	Continuous Output Current	Peak Output Current	Motor Output	Continuous Output Current	Peak Output Current
575 VAC +/- 10% 3 phase		Normal Duty			Heavy Duty		
Order Code	Frame	kW@575V	I _N (A)	I _{PK} (A)	kW@575V	I _H (A)	I _{PK} (A)
SP3501	3	3	5.4	5.9	2.2	4.1	7.2
SP3502		4	6.1	6.7	3.0	5.4	9.5
SP3503		5.5	8.4	9.1	4	6.1	10.7
SP3504		7.5	11.0	12.1	5.5	9.5	16.6
SP3505		11	16.0	17.6	7.5	12.0	21.0
SP3506		15	22.0	24.2	11	18.0	31.5
SP3507		18.5	27.0	29.7	15	22.0	38.5
SP4603 [®]	4	22	36	40	18.5	27	47
SP4604 [®]		30	43	47	22	36	63
SP4605 [®]		37	52	57	30	43	75
SP4606 [®]		45	62	68	37	52	91
SP5601 [®]	5	55	84	92	45	62	109
SP5602 [®]		75	99	109	55	84	147
SP6601 [®]	6	90	125	138	75	100	150
SP6602 [®]		110	144	158	90	125	188
SP6611 [®]		90	125	138	75	100	150
SP6612 [®]	110	144	158	90	125	188	
SP7611 [®]	7	110	168	185	110	144	216
SP7612 [®]		150	192	211	110	168	252
SP8611 [®]	8	200	274	301	150	192	288
SP8612 [®]		250	341	375	200	274	411
SP9611 [®]	9	315	428	471	250	341	512
SP9612 [®]		355	483	531	315	428	642
SP9613 [®]		400	505	556	355	483	725
SP9614 [®]		450	637	701	400	505	758
SP9615 [®]		500	705	776	450	637	956

690 VAC +/- 10% 3 phase		Normal Duty			Heavy Duty		
Order Code	Frame	kW@690V	I _N (A)	I _{PK} (A)	kW@690V	I _H (A)	I _{PK} (A)
SP4601	4	18.5	22	24	15	19	32
SP4602		22	27	30	18.5	22	39
SP4603		30	36	40	22	27	47
SP4604		37	43	47	30	36	63
SP4605		45	52	57	37	43	75
SP4606		55	62	68	45	52	91
SP5601	5	75	84	92	55	63	109
SP5602		90	99	109	75	85	147
SP6601	6	110	125	138	90	100	150
SP6602		132	144	158	110	125	188
SP6611		110	125	138	90	100	150
SP6612		132	144	158	110	125	188
SP7611	7	160	168	185	132	144	216
SP7612		185	192	211	160	168	252
SP8611	8	200	208	229	185	192	288
SP8612		250	263	289	200	208	312
SP8613		315	331	364	250	263	395
SP9611	9	355	374	411	315	331	497
SP9612		400	429	472	355	374	561
SP9613		450	478	526	400	429	644
SP9614		500	526	579	450	478	717
SP9615		560	591	650	500	526	789
SP9616		630	655	720	560	591	887

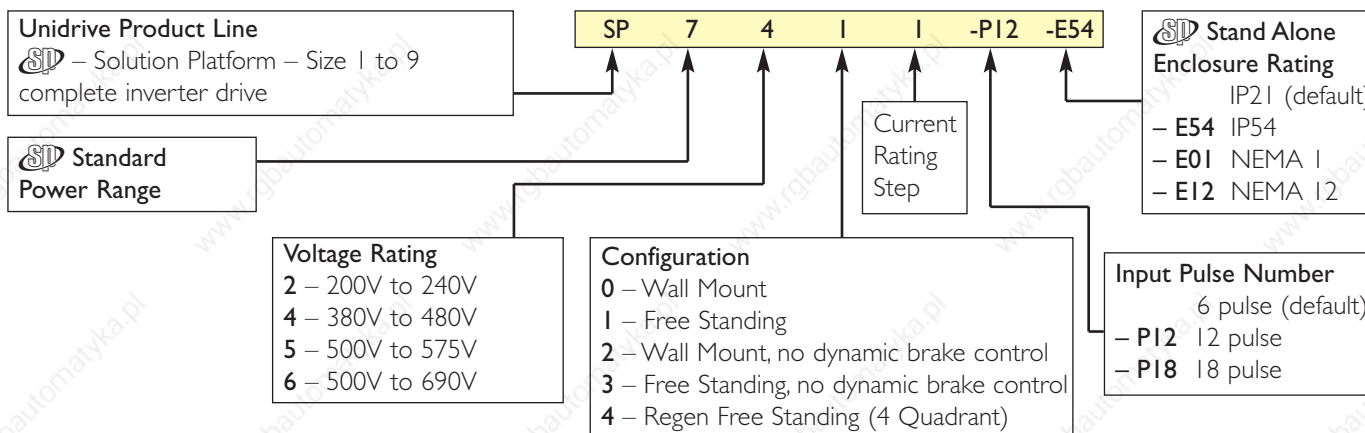

RATINGS – four quadrant regenerative

Unidrive $\mathcal{S}\mathcal{D}$ [®]		Motor Output	Continuous Output Current	Peak Output Current	Motor Output	Continuous Output Current	Peak Output Current
400 VAC +/- 10% 3 phase		Normal Duty			Heavy Duty		
Order Code	Frame	kW@400V	I _N (A)	I _{PK} (A)	kW@400V	I _H (A)	I _{PK} (A)
SP8441	8	110	202	222	90	180	270
SP8442		132	236	260	110	210	315
SP8443		160	290	319	132	240	360
SP8444		200	350	385	160	290	435
SP9441	9	250	440	484	200	350	525
SP9442		315	540	594	250	440	660
SP9443		355	620	770	315	540	810

575 VAC +/- 10% 3 phase		Normal Duty			Heavy Duty		
Order Code	Frame	kW@575V	I _N (A)	I _{PK} (A)	kW@575V	I _H (A)	I _{PK} (A)
SP8641 [Ⓜ]	8	90	125	138	75	100	150
SP8642 [Ⓜ]		110	144	158	90	125	188
SP8643 [Ⓜ]		110	168	185	110	144	216
SP8644 [Ⓜ]		150	192	211	110	168	252
SP9641 [Ⓜ]	9	200	274	301	150	192	288
SP9642 [Ⓜ]		250	341	375	200	274	411

690 VAC +/- 10% 3 phase		Normal Duty			Heavy Duty		
Order Code	Frame	kW@690V	I _N (A)	I _{PK} (A)	kW@690V	I _H (A)	I _{PK} (A)
SP8641	8	110	125	138	90	100	150
SP8642		132	144	158	110	125	188
SP8643		160	168	185	132	144	216
SP8644		185	192	211	160	168	252
SP9641	9	200	208	229	185	192	288
SP9642		250	263	289	200	208	312
SP9643		315	331	364	250	263	392

- ① Motor kW based on four pole, 575 / 690 VAC typical motor ratings. Select model based on actual motor full load current.
- ② The same model can be used on a 575V or a 690V supply, and has two different output ratings. For example: At Normal Duty, SP4603 is suitable for a 22kW output motor on a 575V supply, and a 30kW output motor on a 690V supply.

Normal Duty (open loop)	Suitable for most applications, current overload is set at 110% for 60 seconds. Where motor rated current is less than the drive rated continuous current, higher overloads are achieved.
Heavy Duty (open loop vector, closed loop or servo)	Suitable for demanding applications, current overload is set at up to 175% for 40 seconds. Where motor rated current is less than the drive rated continuous current, higher overloads (200% or greater) are achieved.

UNIDRIVE $\mathcal{S}\mathcal{D}$ REGEN MODE

Unidrive $\mathcal{S}\mathcal{D}$ can be configured to provide full four-quadrant control of the power or drive system. In regen mode, the Unidrive is capable of either supplying power to the DC bus of the Unidrive controlling the motor or removing power from the DC bus of the Unidrive controlling the motor and returning it back to the supply.

- Unity or controllable Input Power Factor
- Sinusoidal Input Current (Low Harmonic Content)

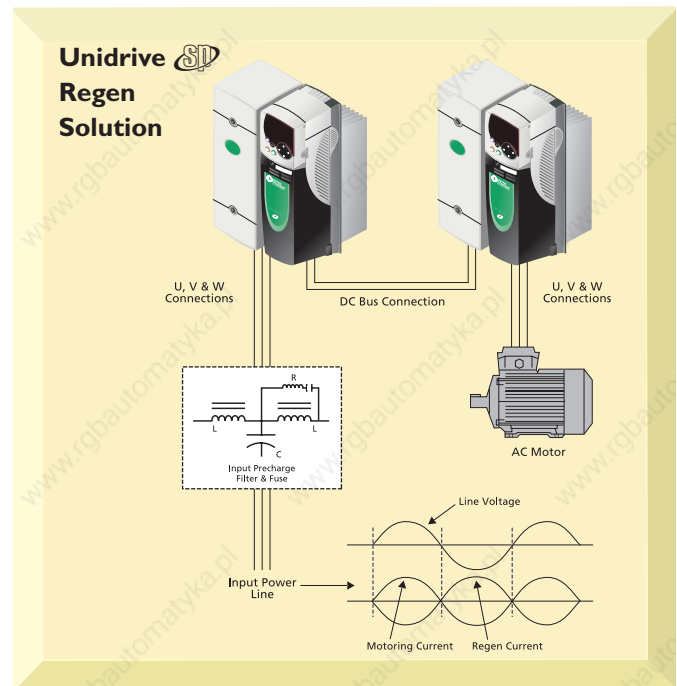

TERMINAL DIAGRAM

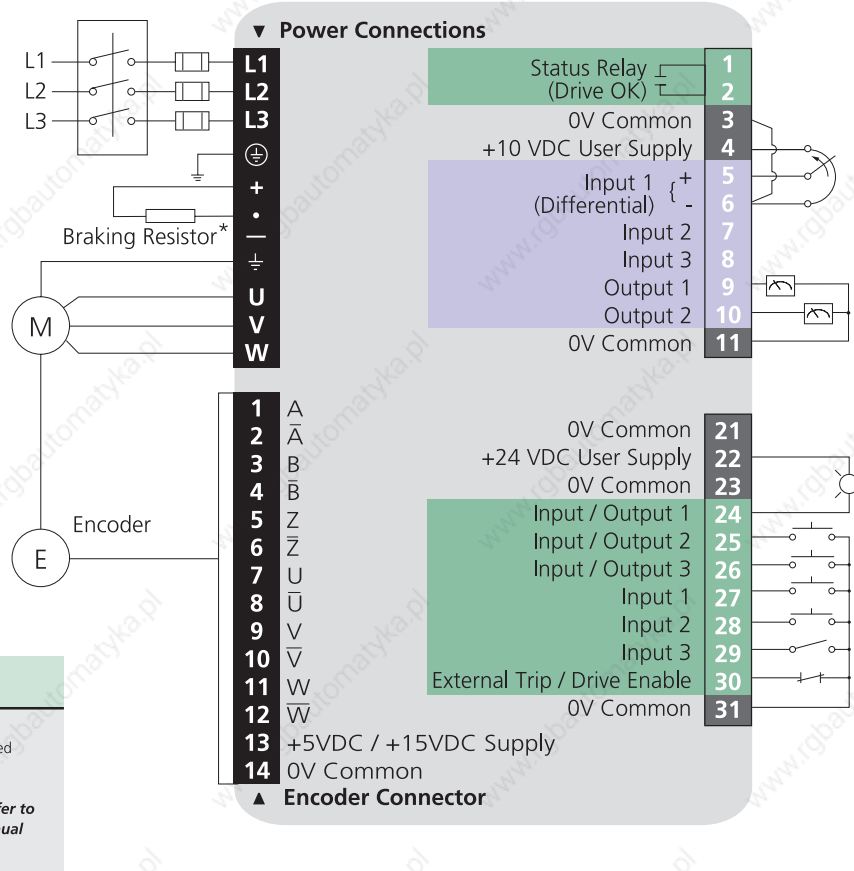

NOTE

* Thermal protection required. Braking Transistors is not included in Unidrive HIHP.

For complete instructions, refer to the Unidrive Installation Manual and User Guide.

TERMINAL DESCRIPTION

Pin#	Function ①	Type/Description	Notes
1	0V Common		
2	+24 VDC External Input	Back up Power Supply for Control	60W, 24 VDC
3	0V Common	Common for External Analog Devices	
4	+10 VDC	Reference Supply	10 mA max
5	Analog Input 1 (Local Frequency / Speed Reference), 16 bit	Differential Analog Input, Non-inverting Input	± 10 VDC, 100k Ohms
6	Analog Input 1 (Local Frequency / Speed Reference), 16 bit	Differential Analog Input, Inverting Input	± 10 VDC, 100k Ohms
7	Analog Input 2 (Remote Frequency / Speed Reference), 10 bit	Single-ended Analog Input	± 10 VDC, 100k Ohms or 4-20 mA _i , 200 Ohms
8	Analog Input 3 (Motor Thermistor), 10 bit (Trip at 3.3kOhm)	Single-ended Analog Input	± 10 VDC, 100k Ohms or 4-20 mA _i , 200 Ohms
9	Analog Output 1 (Frequency / Speed Monitor)	Single-ended Analog Output, Bi-polar	± 10 VDC or 0-20 / 4-20mA
10	Analog Output 2 (Motor Torque Monitor)	Single-ended Analog Output, Bi-polar	± 10 VDC 0-20 / 4-20mA
11	0V Common	Common for External Analog Signals	

Pin#	Function ①	Type/Description	Notes
21	0V Common		
22	+24 VDC	User Supply	200 mA max
23	0V Common	Common for External Digital Inputs	
24	Digital I/O 1 (Zero Speed Output)	Digital Input / Output	0 to 24 VDC input, or 1 to 24VDC, 100 mA max output
25	Digital I/O 2 (Reset Input)	Digital Input / Output	0 to 24 VDC input, or 1 to 24VDC, 100 mA max output
26	Digital I/O 3 (Run Forward Input)	Digital Input / Output	0 to 24 VDC input, or 1 to 24VDC, 100 mA max output
27	Digital Input (Run Reverse)	Digital Input	0 to 24 VDC, 7.5k Ohms
28	Digital Input (Local / Remote)	Digital Input	0 to 24 VDC, 7.5k Ohms
29	Digital Input (Log)	Digital Input	0 to 24 VDC, 7.5k Ohms
30	0V Common	Common for External Digital Inputs	
31	Digital Input (Secure Disable)	Digital Input	0 to 24 VDC, 1µsec sample
41	Status Relay (Drive Healthy)	Normally Open	240 VAC, 2A resistive
42	Status Relay(Drive Healthy)	Normally Open	240 VAC, 2A resistive

① Programmable Analog Programmable Digital All Analog I/O is scalable

① Values in (parenthesis) designate default functions.

② 0-20, 20-0, and 20-4 mA are also available. See Unidrive Manual.

SPECIFICATION

Environment

Ambient Operating Temperature	0° to 40°C
	0° to 50°C with derating
Cooling method	Forced convection
Humidity	95% maximum non-condensing at 40°C
Storage Temperature	-40° to 50°C
Altitude	0 to 3000m. Derate 1% per 100m between 1000m and 3000m
Vibration	Tested in accordance with IEC 68-2-34
Mechanical Shock	In accordance with IEC 68-2-27
Enclosure	IP 20 (NEMA1), IP 54 (NEMA12) through panel mounting
Electromagnetic Immunity	In compliance with IEC801 and EN50082-2, and complies with EN61800-3 with built-in filter
Electromagnetic Emissions	In compliance with EN50081-2 when the recommended RFI filter is used and EMC installation guidelines are followed

AC Supply Requirements

Voltage	200 to 240 VAC ±10%
	380 to 480 VAC ±10%
	500 to 575 VAC ±10%
	500 to 690 VAC ±10%
Phase	3Ø
Phase Imbalance Tolerance	2% negative phase sequence (equivalent to 3% voltage imbalance between phases)
Frequency	48 to 65 Hz
Input Displacement Power Factor	0.93

Control

Switching Frequency	3, 4, 6, 8, 12, 16 kHz
Output Frequency	0 to 3000 Hz (Open loop)
Output Speed	0 to 40,000 rpm (Closed loop)
Frequency Accuracy	±0.01% of full scale
Frequency Resolution	0.001 Hz
Analog Input Resolution	16 Bit + sign (Qty 1), 10 Bit + sign (Qty 2)
Serial Communications	2 or 4-wire RS232 or RS485. Protocol is ANSI x 3.28-2.5-A4, or Modbus RTU Baud rate 300 to 115,200
Braking	DC injection braking (stopping and holding) standard. Dynamic braking transistor standard
Mains Dip Ride Through	Up to 1 second depending on inertia and decel time

Protection

DC Bus Undervoltage Trip	175 / 350 / 435 VDC (approximately 124 / 247 / 307 VAC line voltage)
DC Bus Overvoltage Trip	415 / 830 / 990 VDC (approximately 293 / 587 / 700 VAC line voltage)
MOV Voltage Transient Protection	160 Joules, 1400 VDC clamping (Line to line and line to earth)
Drive Overload Trip	Current overload value is exceeded. Programmable for Normal Duty or Heavy Duty, Open loop or Closed loop operation
Instantaneous Overcurrent Trip	225% of drive rated current
Phase Loss Trip	DC bus ripple threshold exceeded
Overtemperature Trips	Drive heatsink, control board, and option module(s) monitoring
Short Circuit Trip	Protects against output phase to phase fault

Earth Fault Trip	Protects against output phase to ground fault
Motor Thermal Trip	Electronically protects the motor from overheating due to loading conditions

Approvals & Listings

UL, cUL	Listed E171230
IEC	Meets IEC Vibration, Mechanical Shock and Electromagnetic Immunity Standards
CE	Designed for marking
NEMA	NEMA 1 enclosure type
VDE	Meets VDE Electromagnetic Emissions Standards
ISO9001: 2000	Certified Manufacturing Facility
ISO 14001	Certified Manufacturing Facility

DIMENSIONS (mm)

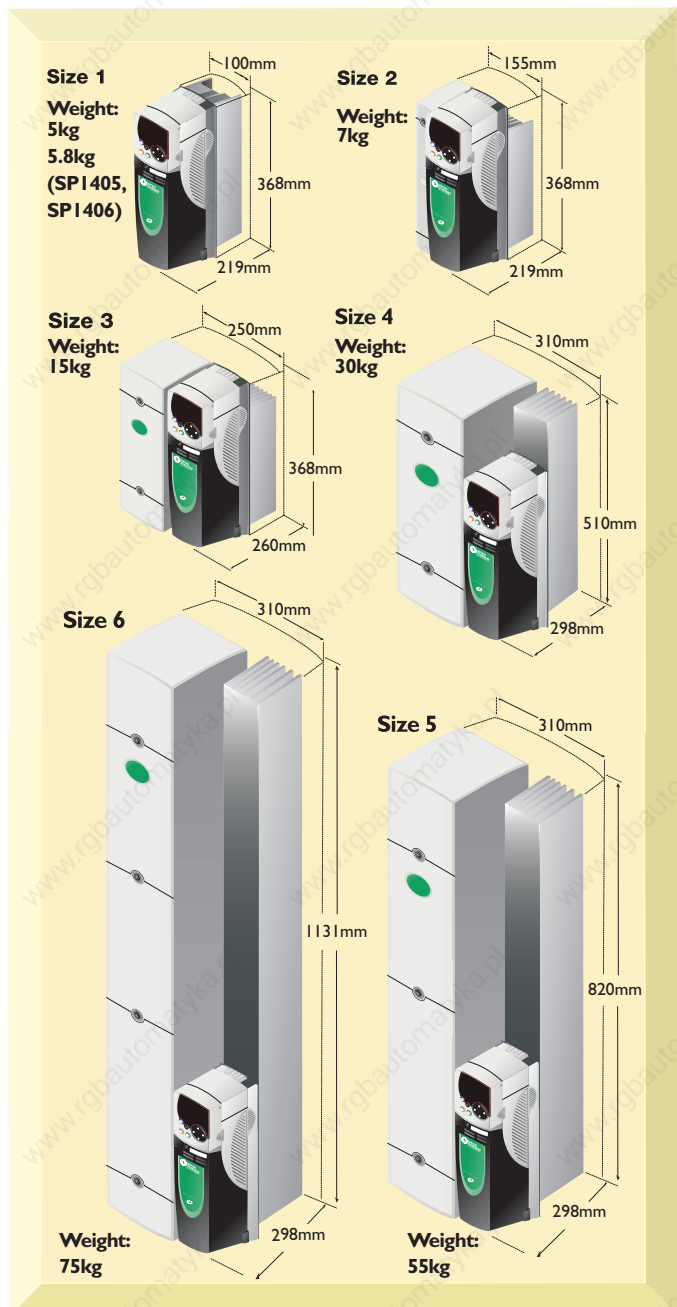

For dimensions of frame sizes 7, 8 and 9 contact your local Drive Centre.

OPTIONS

The Unidrive **SD** provides application and system designers with an incredibly flexible drive platform, which is easily modified by an extensive range of sophisticated SM option modules that can be used singly or in combination for economical and space saving solutions. SM option modules install easily into any of the three option slots, with no tools required. The I/O, feedback, memory, communication and application modules enable the Unidrive **SD** to provide an optimised solution regardless of the demands of the application. A complete range of other accessories are available to simplify system integration and meet system design criteria.

Options At-A-Glance

Option	Description	Order Code
Drive Configuration and Programming	Cloning and Programme Storage Card Configuration Tool Communications Cable	Smart Card*** CTSoft*** CT Comms Cable
Operator Interface	No Keypad LED Keypad Backlit LCD Keypad Operator Interfaces HMI	As standard SM-Keypad SM-Keypad Plus See section 12.3 for details
Power Accessories	Internal Fitting Brake Resistor Panel Mounting DB Resistors E Stop Duty Wall Mounting DB Resistors Cyclic Duty Internal Fitting EMC Filter External Fitting EMC Filters	SM - Heatsink DBR To fit drive To fit drive As standard To fit drive
Motor Feedback	Universal Encoder Feedback Second Encoder Feedback Resolver Input Feedback Encoder Terminal Connector	SM-Universal Encoder Plus SM-Encoder Plus SM-Resolver** SM-ETC
Input/Output	Extra I/O Extra I/O with Real Time Clock Extended I/O Double Insulated Extended I/O 120V I/O Remote Network I/O	SM-I/O Lite SM-I/O Timer SM-I/O Plus SM-PELV SM-I/O 120V Beckhoff I/O
Communication	Modbus RTU (Standard) PROFIBUS-DP INTERBUS DeviceNet CTNet CAN Interface CANopen (SLM) Interface SERCOS Ethernet	SM-Applications* SM-PROFIBUS-DP SM-INTERBUS SM-DeviceNet SM-Applications SM-CAN SM-CANopen SM-SLM SM-SERCOS SM-Ethernet
Application Co-processor Modules	System Programming System Programming Motion Made Easy	SM-Applications SM-Applications Lite SM-EZMotion**
Application Programming Software	SyPT Lite (IEC61131-3) SyPT Pro (IEC61131-3) PowerTools Pro	Free with Unidrive SD SyPT Pro Free download from Control Techniques.com
Solutions Software	Dual Mode Winder Flying Shear Control Fan and Pump Duty Assist	SSP-4000-0010 SSP-4000-0020 SSP-4000-0030

* Provides additional Modbus RTU port.
** Only one of these modules per drive.
*** Supplied as standard with Unidrive **SD**

DRIVE CONFIGURATION AND PROGRAMMING

SMARTCARD

This is a **standard** feature that enables simple configuration of parameters in a variety of ways. The SMARTCARD can:

- 'Clone' a complete set of parameters for serial production
- Save multiple complete sets of parameters
- Set up an application as parameter differences from default
- Automatically save all user parameter changes for maintenance purposes
- Load complete motor map parameters
- Set up an application as parameter differences from default
- Read/write SMARTCARD information from within SM-Applications and SM-Applications Lite



The drive only communicates with the SMARTCARD when commanded to read or write, meaning the card may be "hot swapped".

CTSoft

CTSoft is a complimentary Windows based drive configuration tool designed to enable the complete control and display of all parameters within a Unidrive . Functions within CTSoft allow data to be uploaded, viewed and saved, or retrieved from disk, modified and printed. It can be used off-line in the office or on-line in the factory. CTSoft communicates with the Unidrive via the computer's serial port to the drive's RS485 port using a communications cable (CT Comms cable) or via SM-Ethernet module. For more information, refer to the Set up and Configuration Software Section 9.1.

Some of CTSoft's capabilities include:

- Remote Upload/Download
- Parameter Saving
- Drive and SM-Application Reset
- Monitor Screens
- Multiple Window Display
- Block Diagram Animation
- Project Storage

CTSoft IS SUPPLIED WITH THE DRIVE OR YOU CAN DOWNLOAD FROM www.controltechniques.com/download.htm

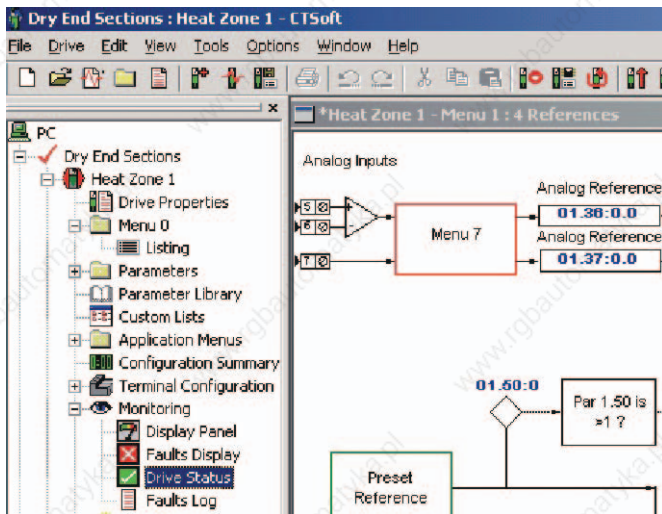

Communications Cable

Using a special RS232 to RS485 converter you can connect the PC to the RJ45 serial port on the front of the drive. A special pre-made cable is available from Control Techniques for this purpose – this same cable is used with other Control Techniques products that use a RJ45 RS485 connector such as the Commander SE.

The RJ45 socket is located under a small flap on the front of the Unidrive just below the keypad. The pin-outs of this connector are described in the Unidrive User Guide.



Order Code	Description
CT Comms Cable	PC-to-drive Comms Cable
USB CT Comms Cable	USB-to-drive Comms Cable

OPERATOR INTERFACE

Keypad Options

The Unidrive can operate without a keypad, or with either the SM-Keypad or SM-Keypad Plus. The SM-Keypad is a full-function, 7-digit LED data display. The SM-Keypad Plus is a back-lit LCD display option that can be remote mounted, has 5 languages, plus custom text database, on-line help, and HMI features. Both keypads are "hot-pluggable," enabling them to be moved from one drive to another without powering down.



SM-Keypad + No Keypad



SM-Keypad Plus

Operator Interface Unit (HMI)

The HMI operator interface units have a range of features including a back-lit LCD display and easy-to-use navigation keys.

Using the intuitive "WYSIWYG" page editor, they can be programmed to display a variety of menus, submenus, alarms, fault conditions and other critical information. The HMIs support a range of capabilities including multiple font sizes, real time trends and graphs, scheduling and background programs. They communicate via Modbus RTU and, to simplify installation, some HMIs are rated IP54 and require no screw mounting holes.

For more information, refer to the Network Communications Section 12.3.

Operator Interface Range



HMI 200

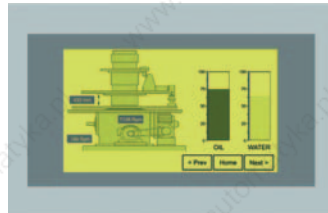

VT155W



TIU500

POWER ACCESSORIES

Internal Dynamic Braking Resistors

Dynamic braking resistors provide a means of rapidly stopping motor and load. The mechanical energy stored in the spinning mass is converted into electrical energy and quickly dissipated into the resistor. The ohmic value and power rating of the resistor is a function of the drive type.

A dynamic braking resistor is available for heatsink mounting on size 1 and 2 drives. No external thermal protection device is required as resistors are electronically protected by drive firmware.

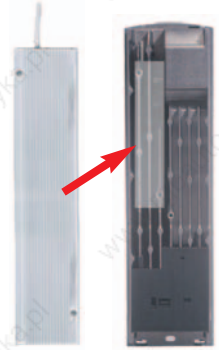

Size 1 Unidrive heatsink shown

Unidrive Size	DC Resistance	Power Rating
1	75 R	100W
2	37.5 R	200W

E-Stop Duty Dynamic Braking

Panel mounted DB resistors are designed for non-cyclic use where energy dissipation from an active drive is required. Resistors are supplied with mounting hardware unless otherwise noted.

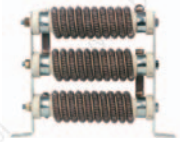

Cyclic Duty Dynamic Braking

These heavy-duty kits have been designed to provide dynamic braking for cyclic and continuous braking applications.

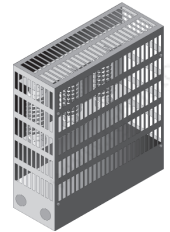

Onboard EMC Filter

An internal EMC filter is provided as standard with the Unidrive . It is adequate for most industrial applications. The filter conforms to EN61800-3 (second environment) when motor cable length does not exceed a certain length depending on the model.



External EMC filters

EMC filters are used to minimize high frequency power supply line disturbances caused by PWM AC drives that may interfere with proper operation of sensitive electronic equipment. These specific filters have been assessed for conformance with the EMC directive by testing with the appropriate Control Techniques drives.

Mounting Style

- Bookend: filter mounts next to the drive with the smallest dimension being the width of the filter
- Footprint: filter mounts between the drive heatsink and the panel or enclosure
- Block: filter mounts on the panel near the drive



Optional External EMC Filters

Drive	Order Code	Drive cont.	Order Code
SP1201 to SP1202	4200-6118	SP3401 to SP3403	4200-6305
SP1203 to SP1204	4200-6119	SP4401 to SP4403	4200-6406
SP2201 to SP2203	4200-6210	SP5401 to SP5402	4200-6503
SP3201 to SP3202	4200-6307	SP3501 to SP3507	4200-6309
SP4201 to SP4203	4200-6406	SP4601 to SP4606	4200-6408
SP1401 to SP1404	4200-6118	SP5601 to SP5602	4200-6504
SP1405 to SP1406	4200-6119	SP6401 to SP6402	4200-6603
SP2401 to SP2404	4200-6210	SP6601 to SP6602	4200-6604

For filters beyond SP6602 consult local Drive Centre.

MOTOR FEEDBACK

The Unidrive has a built-in Universal encoder port that accepts the following signal types:

- Quadrature Incremental
- Pulse and Direction
- Forward and Reverse Pulses
- Quadrature with commutation
- Forward and Reverse Pulses with commutation
- SinCos without commutation
- Absolute SinCos using EI485 serial protocol
- Absolute encoder
- Absolute SinCos using serial communications protocol
- Absolute encoder
- Commutation only eg Hall Effect devices



Universal Encoder Port

SM-ETC



Encoder Terminal Connector

The 15 way D-Type Converter is used to simplify motor feedback wiring by "Breaking out" the 15-pin D-connector signals to screw terminals.

SM-Universal Encoder Plus

The SM-Universal Encoder Plus module provides the Unidrive with an additional feedback port with the same functionality as the base drive, plus a simulated encoder output that can be programmed to operate in the following modes:



- SinCos with Commutation
- Quadrature Incremental
- Pulse and Direction
- SSI

The module also incorporates freeze inputs for applications requiring position capture.

SM-Encoder Plus

The SM-Encoder Plus module provides an additional incremental encoder feedback port.



More than one SM-Encoder Plus and/or SM-Universal Plus Encoder module may be installed in a single drive.

SM-Resolver

This module enables the Unidrive to control the speed and position of motors fitted with resolvers. Because of their ruggedness, resolvers are often used in hot, demanding environments.



- Input Impedance:** >85 Ohms
- Transformation Ratio:** 3:1 or 2:1
- Excitation Frequency:** 6kHz
- Excitation Voltage:** 6V or 4V rms sine wave

Maximum Motor Speed	Feedback Resolution	Simulated Encoder Output (ppr)	
		Quadrature Format	Frequency & Direction
0-3,300 rpm	14 bit	4096	8192
3,301-13,200 rpm	12 bit	1024	2048
13,201-40,000 rpm	10 bit	256	512

The encoder simulated output can be sourced either from the resolver or the main drive encoder.

INPUT/OUTPUT

SM-I/O Lite

Additional I/O (1 x Analog Input ($\pm 10V$ bi-polar or 4-20mA), 1 x Analog Output (0-10V or 4-20 mA), 3 x Digital Output and 1 x Relay).

SM-I/O Timer

As per SM-I/O Lite but with the addition of a Real Time Clock for scheduling drive running.

SM-I/O 120V

Additional I/O conforming to IEC6 1131-2 120VAC. 6 inputs and 2 non-protected relay outputs rated for 120VAC operation.

SM-I/O PELV

Double Insulated Extended I/O to NAMUR NE37 specifications for chemical industry applications.

SM-I/O Plus

This module enables the drive system designer to solve more complex applications by providing additional inputs and outputs that the Unidrive can access locally. These connections are on removable terminal strips and are programmable using CTSoft or the drive's keypad.

SM I/O Plus Terminal Diagram

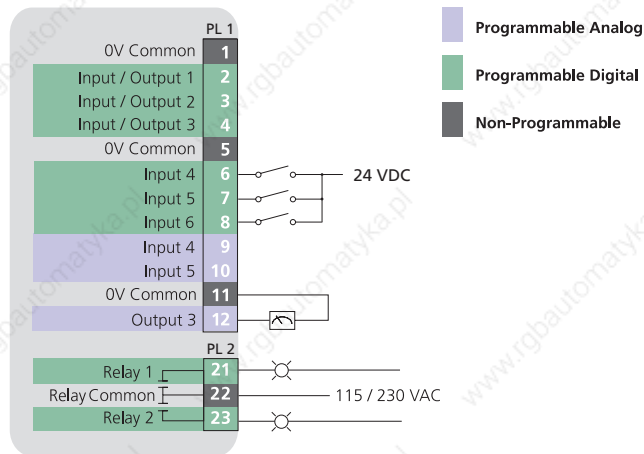

SM I/O Plus Terminal Description

Quantity	Description	Notes
2	Relay Contacts (N.O.)	110 VAC, 2 A resistive
3	Digital Input	+24VDC, 7.5k Ohms
3	Digital Input / Output	+24 VDC, 7.5k Ohms / +24 VDC @ 10 mA max.
2	Analog Voltage Input	± 10 VDC, 20k Ohms, 10 bit
1	Analog Voltage Output	± 10 VDC @ 30 mA max., 10 bit

Remote Network I/O

The high-quality Beckhoff I/O system is available for CTNet systems. Beckhoff systems for CTNet include an I/O bus coupler and a large variety of snap-on terminal blocks allowing up to 256 digital inputs or outputs and up to 100 analog inputs and outputs per bus coupler. Up to 64 Beckhoff I/O systems can be attached to a CTNet network. I/O points can be easily read or written. Contact Control Techniques for details on the wide range of available Beckhoff Remote I/O options.

COMMUNICATION

SM-DeviceNet



SM-PROFIBUS - DP



SM-SLM



SM-CANopen



SM-INTERBUS



SM-SERCOS



CT Net and Modbus RTU via SM-Applications



SM-CAN



SM-Ethernet



Communications Protocol	Interface Module Order Code	System Configuration
Modbus RTU*	SM-Applications	Master/Slave
PROFIBUS-DP	SM-PROFIBUS-DP	Slave
INTERBUS	SM-INTERBUS	Slave
CTNet	SM-Applications	Peer-to-Peer
DeviceNet	SM-DeviceNet	Slave
CANopen	SM-CANopen	Slave
CAN Interface	SM-CAN	Master/Slave
SERCOS	SM-SERCOS	Slave
ModbusTCP/IP	SM-Ethernet	Slave
SMTMP Mail		Slave
FTP Filetransfer		N/A
SLM	SM-SLM	Slave

* Modbus RTU is standard. An additional Modbus RTU port can be provided with an SM-Applications module.

SM-SLM

The SM-SLM module allows connection to Control Techniques' high performance digital servo system, offering over 8,000,000 counts per revolution velocity feedback. For performance benefits of (SLM) technology see section 7.2 for centralised motion control.



Fieldbus Connectivity

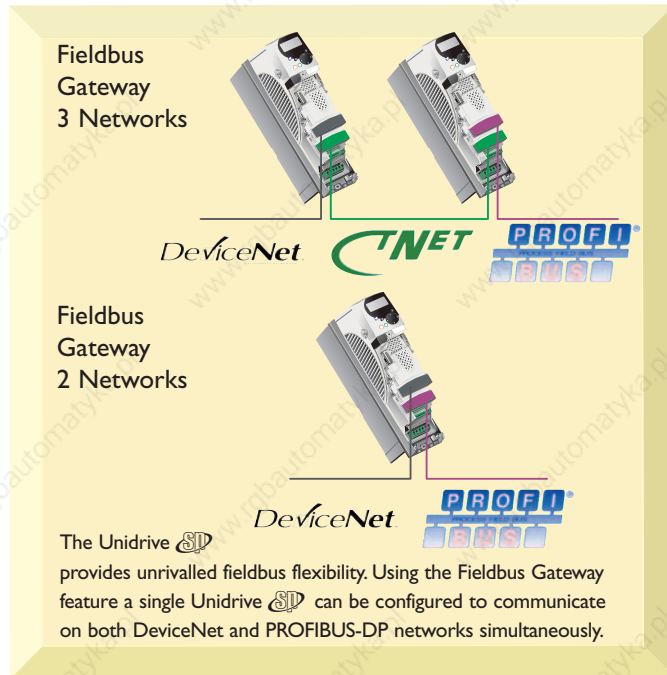



APPLICATION MODULES

SM-Applications

The SM-Applications module transforms your Unidrive  drive into a powerful automation controller that adds PLC functionality and can be devices via our drive-to-drive network CTNet. This gives you all of the benefits of a fully distributed control system including better performance, reduced cost and smaller electrical panel sizes.



Performance – The SM-Applications module contains its own high performance microprocessor, leaving the drives own processor to give you the best possible motor performance. It contains 384K of user program memory, meaning that you are never likely to be limited by the program size or processing power of the module.

Easy Powerful Configuration – The PLC functionality is programmed using  (System Programming Tool) allowing you to tackle automation problems from simple start and stop sequencing through to more complex machine and motion control applications. The device is programmed within an IEC61131-3 environment with your choice of 3 languages, meaning that you will be quickly familiar with the  intuitive user interface.  provides a suite of diagnostic and

debugging features for maintenance and to help you to get your solution into service faster.





Real Time Control – SM-Applications gives you real-time access to all of the drives parameters plus access to data from I/O or other drives. The module uses a high-speed multi-tasking operating system with task update times as low as 250µs, fully synchronised to the drives own control kernel to give you the best possible performance for drive control and motion.

Inputs/Outputs – The module has two digital inputs and two digital outputs for high-speed I/O operations such as position capture or actuator firing and a fast optically isolated RS485 port, supporting standard protocols such as; Modbus for connection to external devices like Operator Interface panels or synchronous communication using the  protocol.

SM-Applications Lite

The SM-Applications Lite module is designed to solve your automation requirements where intelligence is needed on a standalone drive or a drive connected to a centralised controller via I/O or Fieldbus.



The Module provides many of the functions of SM-Applications but may be programmed using either  or . SM-Applications Lite with  gives you an intermediate level automation solution that is suitable for a wide variety of applications, while  and SM-Applications Lite will allow you to exploit the full power and performance of the option module in 'stand-alone' applications.

SM-EZMotion

The SM-EZMotion is ideal for all of your motion control applications whether simple or highly complex. Windows™ based PowerTools Pro configuration software helps to simplify applications whilst maintaining flexibility and functionality.



The module is equipped with four high speed digital inputs and two digital outputs for external control. Simplify all of your motion applications by using the built-in High-Speed Capture, Queuing, Profile Summation, and Program Multi-tasking capabilities.

Ease of use defines this multipurpose motion controller. Take advantage of all its features to quickly solve these applications:

- Simple Indexing
- Pick and Place
- Flying Shear
- High Speed Labeling
- Phase Synchronisation
- Random Infeed Control
- Rotary Knife
- And many more...

APPLICATION PROGRAMMING SOFTWARE

SyPTLite

SyPTLite is a ladder diagram editor that allows you to develop programs that can be executed onboard Commander SK with LogicStick, onboard the Unidrive SD built-in PLC or on SM-Applications Lite option modules.

SyPTLite is designed to meet the needs of the majority of automation users wishing to extend the functionality of the drive to add simple PLC functionality such as drive control and sequencing. The software has been developed with a focus on intuitive ease of use allowing you easy access to all of the drives parameters and to monitor and debug your program on line.

SyPTLite contains a comprehensive library of functions that are based on a subset of those available in the SyPTPro programming tool. These include:

- Arithmetic Blocks
- Comparison Blocks
- Timers
- Counters
- Multiplexers
- Latches
- Bit Manipulation
- SMARTCARD

SyPTLite with Unidrive SD onboard PLC

Unidrive SD supports ladder-programming capability, i.e. the drive itself is capable of storing and executing a SyPTLite program without the requirement for additional option modules. The drive is prioritised to execute all motor control related functions first and will use any remaining processing time to execute the SyPTLite ladder diagram as a background activity.

The SyPTLite program may be copied to or from the SMARTCARD on the drive, allowing the data to be safely stored or retrieved for serial machine manufacture and maintenance purposes.

SyPTLite with SM-Applications Lite and Unidrive SD

The SM-Applications Lite contains it's own high-performance microprocessor, of the same type as used in the drive, giving you access to a step change in PLC power and more than doubling the program size available up to 10kb. Using this option module gives you the flexibility to decide how your program task will run, either background or cyclic. The cyclic task means that the program will start on a fixed time-base that is synchronised with the drives own internal control loops. The time-base is selectable between 1 – 200ms.

SM-Applications Lite and SyPTLite offer a compelling alternative to traditional mini-PLC systems, in applications where cost, foot print size and performance are critical.

Note: Full SM-Applications does not support SyPTLite programs.



FREE Software SyPTLite IS SUPPLIED FREE WITH THE DRIVE OR VISIT www.controltechniques.com/download.htm

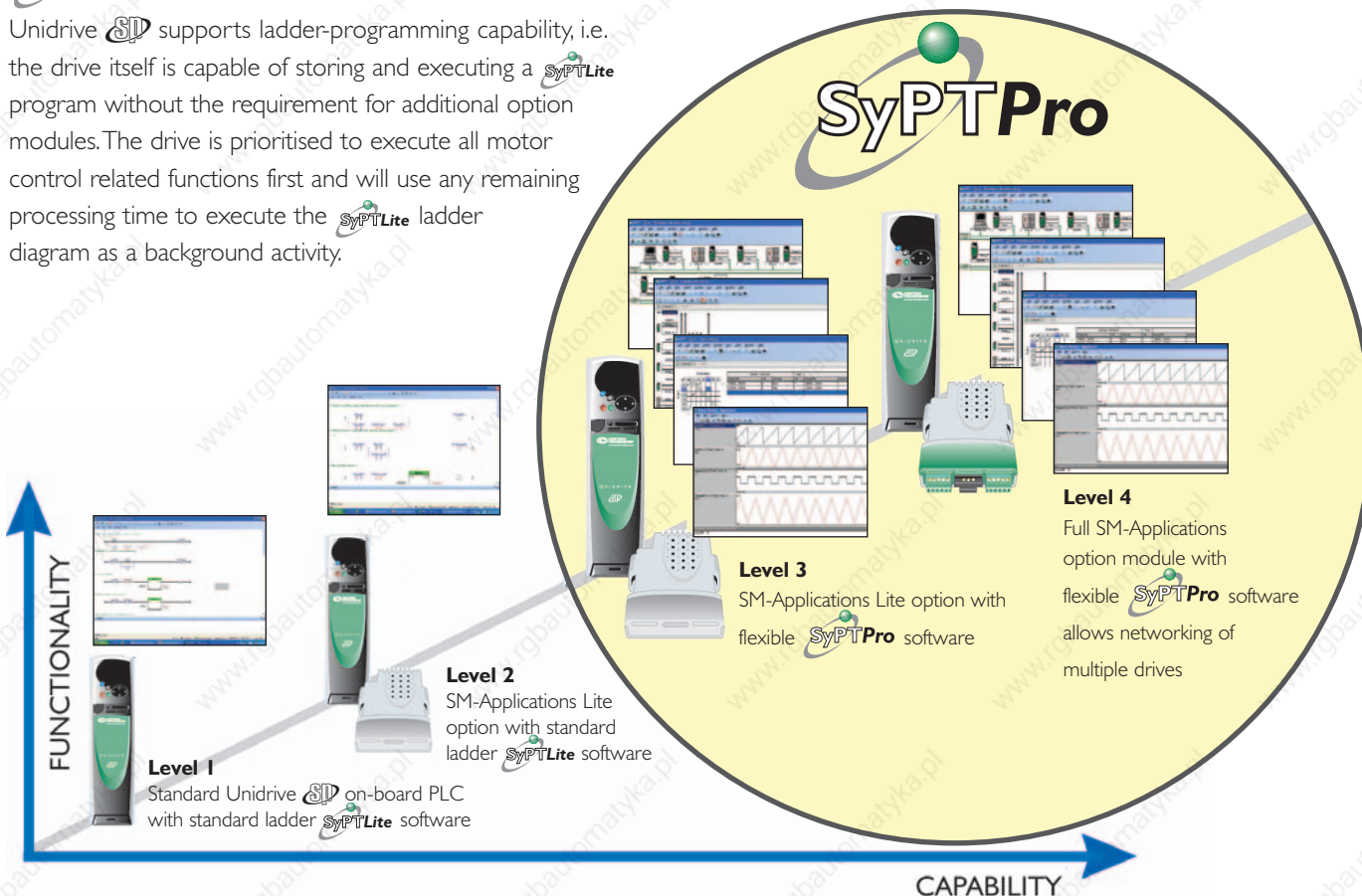

SyPTPro – System Programming Toolkit

Overview – SyPTPro is the professional drive programming toolkit for OEM's and End Users who wish to maximise the performance of their machines and factory. This IEC61131-3 programming software offers greatly enhanced functionality allowing you to connect drives, Operator Interfaces and I/O to a network and configure how they exchange data. SyPTPro allow you to program in your choice of three different languages, with a real-time multi-tasking environment. It contains a suite of monitoring and diagnostics features that help you to reduce the time it takes to develop your programmes and allows you to get your machine into service faster.

SyPTPro may be used to program Unidrive SD with SM-Applications and SM-Application Lite option modules



(and Mentor II DC Drive with MD29 option modules).

Industrial Network – SyPTPro allows you to configure a single drive or a complete drive system connected to a network. CTNet is an industrial network designed to be deterministic, robust and tolerant to noise and interference. An OPC server is available free of charge from your local Control Techniques Drive Centre or Distributor.

Programming – SyPTPro allows you to program in your choice of three programming languages; Function block diagram, Ladder diagram and DPL (Drive Programming Language). And offer a multi-tasking environment where the tasks are scheduled according to the required speed of execution or triggered by events.

Function Block – SyPTPro incorporates an IEC61131-3 function block diagram editor, and comes with a library of more than 250 function blocks for both simple and complex functions. These embed years of application experience to make your software easier to write and easy to re-use. Additionally you can create a library of your own function blocks or update your library via our online user resources – SyPTPro.com. All function blocks may be used in any of the three languages.

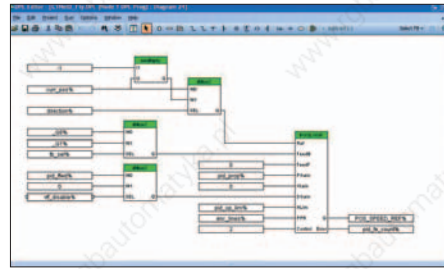

Ladder – SyPTPro incorporates an IEC 61131-3 Ladder language editor. This form of programming will be familiar to all PLC programmers and is the ideal format for sequencing and I/O control.

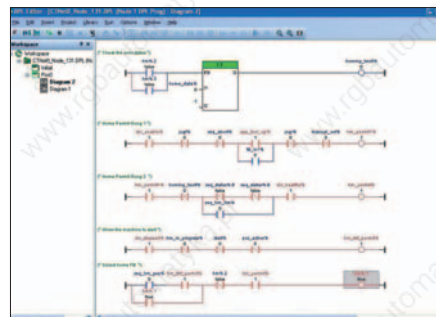

DPL – Drive Programming Language is a structured text language, as easy to use as BASIC, incorporating many standard constructs, such as IF, THEN, ELSE, and FOR, NEXT loops. DPL is ideal for initialising, configuration and general programming.

Diagnostics and debugging – Good diagnostics are essential and ensure:

- Software development time is minimised.
- Commissioning time is reduced.
- Down time is cut dramatically.

SyPTPro contains a suite of diagnostic tools that help you to find problems with the system or software quickly and easily. When connected on-line, SyPTPro shows you live real-time views of variables in Function Block Diagrams, Ladder Diagrams and DPL, and allows you to execute program stepping and breakpoints.

System Watch Window – Allows you to monitor real-time variables and parameters from a single drive or multiple drives.

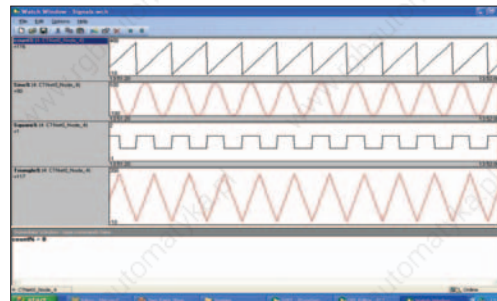

POWERTOOLS PRO FOR UNIDRIVE AND SM-EZ MOTION

The PowerTools Pro software in combination with the SM-EZMotion module enables you to fully realise the motion control power of the Unidrive . A familiar Windows™ interface provides operators and machine builders with the tools needed to access everything required for complete servo control– PLS, Queueing, Analog-In, User Variables, High-Speed Capture, Electronic Gearing, Multiple Profile Summation, S-Curve Accel and Decel, Program multitasking, Synchronised motion, and more.

Developing applications with PowerTools Pro is an easy “five-step, top-down” process that quickly gets your applications running. The five task areas that need to be completed in order are found in the Windows™ Hierarchy View – Hardware, Setup, I/O Setup, Motion, Programs and Network. Some areas may not need completing, as some applications, such as a “flying cutoff” may not require “programming” nor network parameters to operate.



- Programming software for the SM-EZMotion module that gets applications up and running quickly, from the simple to the complex
- Hierarchy View provides for an easy, flexible, and powerful programming environment
- Familiar Windows™-based processes simplify entering data
 - “Fill-in-the-Blank” Values
 - “Point and Click” Radio Buttons
 - “Scrolling” Menu Selections
 - “Drag and Drop” parameters and I/O assignments
- Online Watch window for diagnostic, fault, and parameter updates



OR VISIT www.controltechniques.com/download.htm

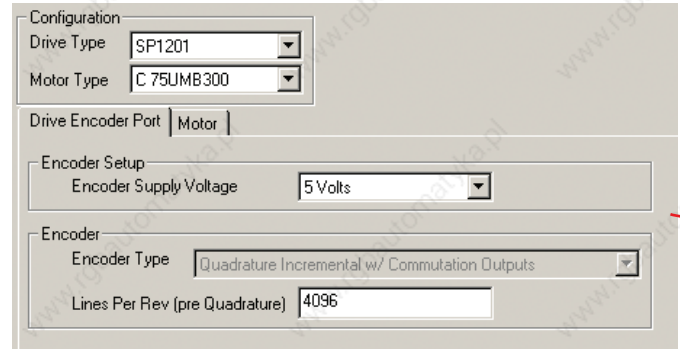

An unexpanded Hierarchy View is shown on the left-hand side of the SM-PowerTools startup screen.

User Units

User Units are the first item under Setup on the PowerTools hierarchy. User units deliver high resolution performance and ease of use. Motion can be programmed in any units that the user desires. Setup the 32-bit data resolution for position, velocity, and acceleration data one time and the rest is done for you. Select from optional time scales for Velocity and Acceleration units.

Programs

Combine program flow and motion instructions to create fully customised user programs up to 1,000 lines of code. Use conditional branching, wait for, program calls, formulas, user variables, and numerous motion instructions to solve your complex applications. Easily create programs, such as the drill head positioning program below, by dragging and dropping, or typing program instructions, variables, I/O, and formula operands into your program screen. Use the SM-EZMotion module to run one program at a time, or up to four programs simultaneously!

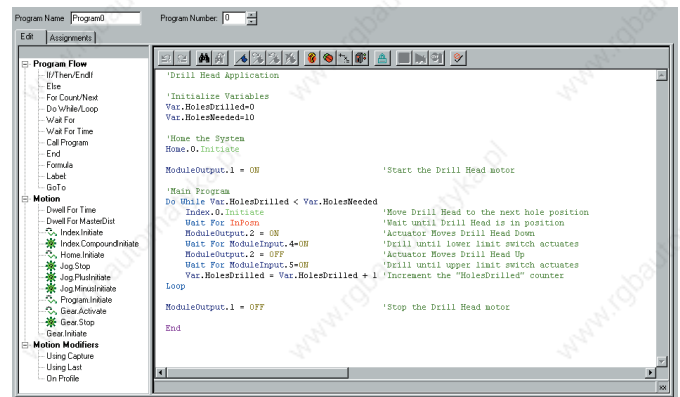

Expanded Hierarchy View

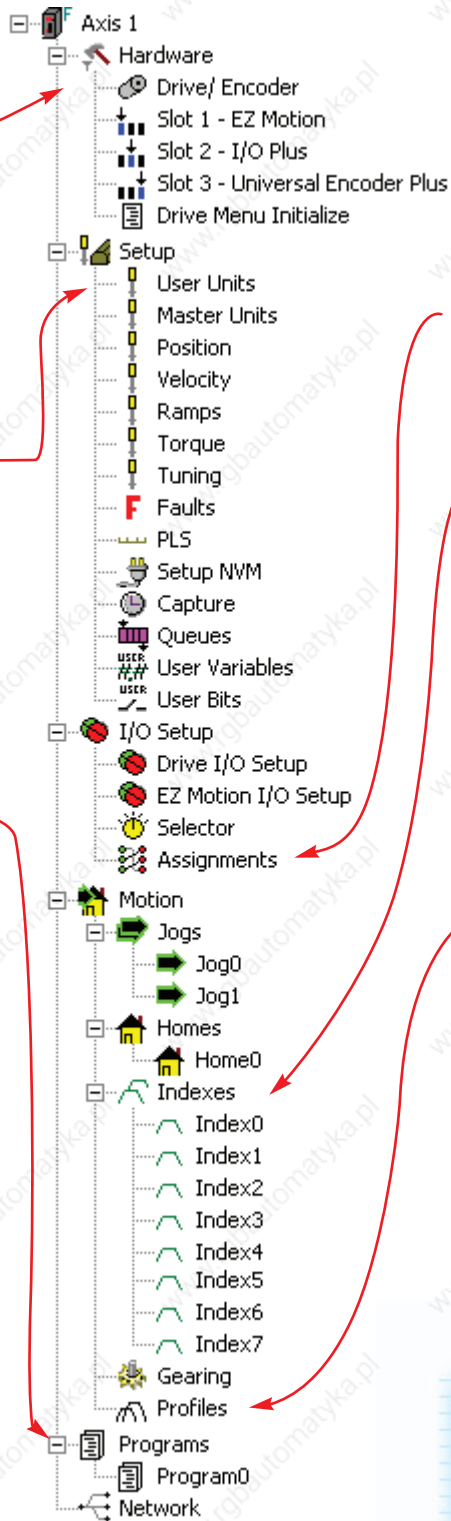

Source	Assigned to	Polarity	Destination	Set From	Polarity
InitiallyActive	PLS.0.PLSEnable	Active On	DriveOutput.1	Index.0.AirVel	Active On
Index			Index		
Cut	Index.0.AirVel	Active On	Cut	Index.0.Status	Active On
	Index.0.CommandComplete	Active On	Retract	Index.0.CommandComplete	Active On
PLS			Home		
PLS0	PLS.0.Status	Active On	Home0	Home.0.Initiate	Active On
Inputs			Home0	Home.0.SensorTrigger	Active On
DriveInput.1	Home.0.Initiate	Active On	PLS	PLS.0.PLSEnable	Active On
DriveInput.2	Home.0.SensorTrigger	Active On	Ramps	Stop	Active On
DriveInput.3	MasterAxis.DefineHome	Active On	Master	MasterAxis.DefineHome	Active On
	Stop	Active On			

Assignments

Use our "Virtual Wiring" to create programs right out of the box, without writing a "line of code." For example, the assignment screen below shows how easily a flying cutoff routine can be created.

Indexes

Setting up indexes is easily accomplished by filling in the screen's blanks to create an index profile. Select from Incremental, Absolute, Rotary Plus and Minus types. Choose the time base of the index by selecting either realtime or synchronised to a master.

Index Number: 0
 Index Name: Index0
 Index Type: Incremental
 Time Base: Realtime

Distance: 50 mm
 Velocity: 2000 mm/m
 Acceleration: 10000 mm/m/s
 Deceleration: 2000 mm/m/s

Enable Index PLS
 PLS On Point: 0.0000 mm
 PLS Off Point: 0.0000 mm

Calculations		Registration		Assignments	
Start Position	0.0000 mm	Peak Velocity Attainable	2000 mm/m		
Index Distance	50.0000 mm	Index Time	2.1000 Seconds		
Accel Distance	3.3333 mm	Accel Time	0.2000 Seconds		
At Velocity Distance	30.0000 mm	At Velocity Time	0.9000 Seconds		
Decel Distance	16.6667 mm	Decel Time	1.0000 Seconds		

Graph: Velocity (mm/m) vs Time (Seconds). Shows a trapezoidal profile starting at 0, reaching 2000 mm/m, and decelerating to 0 at 2.00 seconds.

Example Index screen

Profiles

This function allows the user to simultaneously execute any two motion types together resulting in a summed profile (i.e. Gear + Index, Jog + Index, Index + Index, etc.). Summing profiles is ideal for phasing applications such as Random Infeed, Rotary Knife, Merge Conveyor, and any number of other applications.

```

Gear.initiate on Profile.0
Index.0.Initiate on Profile.1
Wait for Index.0.CommandComplete
Wait for Time .25 'second
Index.1.Initiate on Profile.1
    
```

Multiple Profiling

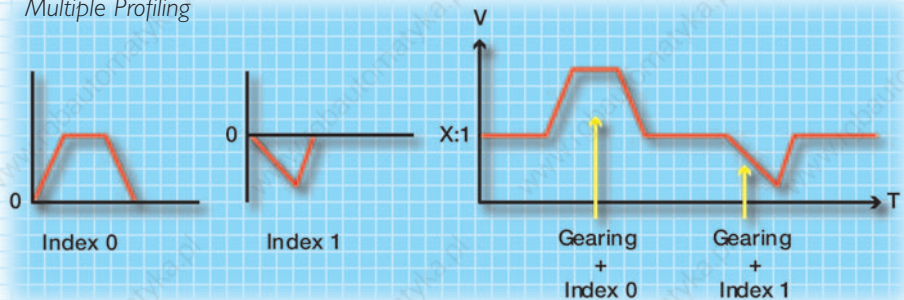

solutions

DUAL MODE WINDER

The Dual Mode Winder Application Software is the result of over 35 years of programming successful winder applications for a wide variety of materials and industries.

The term “Dual Mode” refers to the ability of the software to switch between torque and speed control modes, often a critical requirement in demanding applications such as high speed dual-turret, flying splice machines. The Dual Mode Winder Application Software supports over 95% of industrial winding applications.

The addition of a co-processor option module loaded with the Dual Mode Winder software provides a low cost flexible solution for a wide variety of winding applications.

Paper and Film Unwind and Rewinders

- Single or multi spindle
- Low tension high speed unwinds

Metal Coilers and Uncoilers

- Speed based control for thin strip with precise tension control
- Torque based control for heavy strip without tension feedback
- Speed/Torque control switching on the fly

Wire, Cable and Textile Spoolers

- Torque or speed controlled spoolers

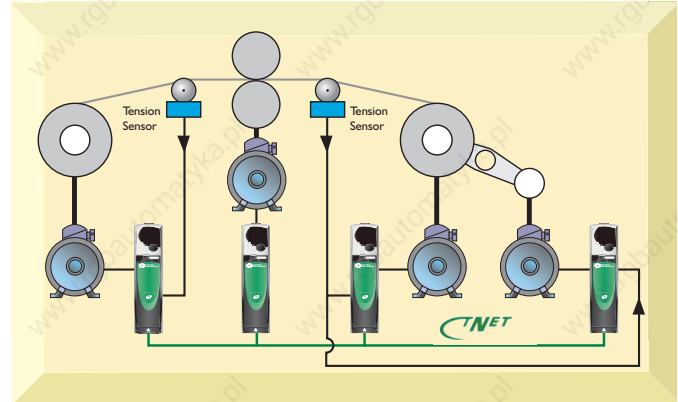

Standard Features

- Torque Control Mode, including Constant Tension Centre Wind
- Speed Control Mode
- Dancer Feedback
- Load Cell Feedback
- Dancer Air Loading Output
- Line Speed Input
- Diameter Calculator
- Inertia Compensation
- Taper Tension – linear or hyperbolic
- Unwind/Rewind Selection
- Web Break detection
- Stall Tension adjustment
- Multiple Preset Diameters
- Jog
- Torque Memory
- All data entry done using Engineering Units

Accessories

- Fieldbus communication options: Modbus, DeviceNet, CANopen, PROFIBUS DP, INTERBUS, Ethernet and CTNet
- Expanded I/O option
- CTNet Modular I/O
- Range of HMIs
- Dynamic Braking
- Regenerative Braking

Solutions Software	Order Code
Dual Mode Winder	SSP-4000-0010



FLYING SHEAR CONTROL

The Flying Shear is a common industrial application for cutting a continuous product to a set length while at line speed. This means that the main production process is not interrupted, and so machine productivity is maximised.

Typical applications include various types of cut to length machines, depositors, punches, product inspection, or any other process where synchronisation at line speed is required.

Standard Features

- Easy configuration
- Hardware and software limits
- Manual jog functions
- Several homing modes
- High speed output is used to initiate the cut
- Registration capture
- Batch control functions
- Dynamic motion profile changes on the fly
- Engineering units are used for programming
- Units are defined for the master and slave axis as the number of encoder counts per unit. These are entered as a numerator and denominator to allow fractional values
- Resolution of the 'cut-length' may be entered to within 0.001 units
- Profile optimization reduces the machines mechanical stress: The return profile is calculated to operate at the slowest speed and acceleration rate, and yet with sufficient time to achieve the next cut, either triangular or trapezoidal profiles are used
- Parallel and angled carriage applications are handled

Flying Shear – Inline

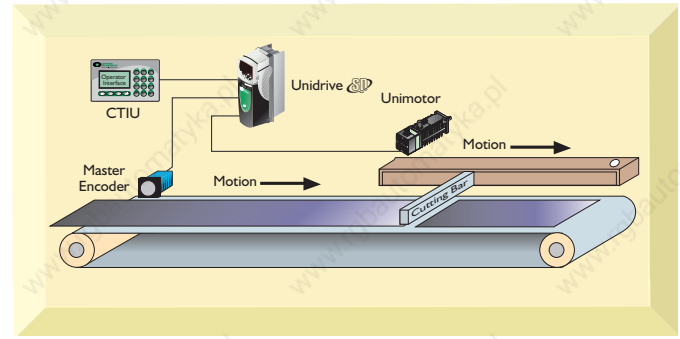

Flying Shear – Angled

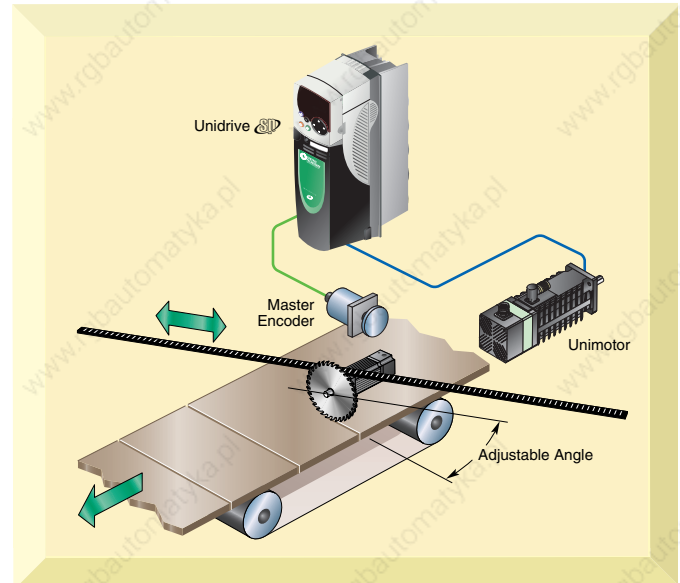

Solutions Software	Order Code
Flying Shear Control	SSP-4000-0020

Accessories

- Fieldbus communication options: Modbus, DeviceNet, CANopen, PROFIBUS DP, INTERBUS, Ethernet and CTNet
- Expanded I/O option
- CTNet Modular I/O
- Range of HMIs
- Dynamic Braking
- Regenerative Braking



FAN & PUMP DUTY ASSIST

The Duty-Assist control is an effective method of controlling multiple pumps or fans in parallel to maintain the required process demand. Pumps and fans are often used in parallel banks to avoid motor overload, guarantee security of supply through system redundancy, reduce running costs due to system load cycles, and provide a wide range of control and flexibility.

The system consists of a 'Duty' Drive and assist starters. The assist starters can be of any type, (e.g. Contactor; Wye-Delta, Auto-Transformer; Soft Starter or Inverter); the choice is dependent on the system limits. The Duty drive can control one dedicated motor (Fixed Duty), or with additional external switchgear could be selected to control other motors within the parallel configuration (Flexible Duty).

Standard Features

- Fixed Duty Motor – up to 4 assist starters can be controlled
- Flexible Duty Selection – up to 3 assist starters can be controlled
- Assist or Duty selection by Runtime (to ensure each pump/fan is equal used) or a set sequence
- Automatic reselection requested assist fails to start
- Local/Remote: Digital control from Unidrive terminal I/O or via fieldbus
- Stand-alone or system configurable
- Set-points and feedback can be derived as direct analog signals or by fieldbus
- 2 selectable process set points for use with day/night function
- Process High and Low trip thresholds (selectable)
- Inverse Speed characteristic (selectable)
- No Flow Protection (selectable)
- Wake/Sleep, Energy save function (selectable)
- Dynamic V/F, Energy save function (selectable)
- Cascade System Stop (selectable)

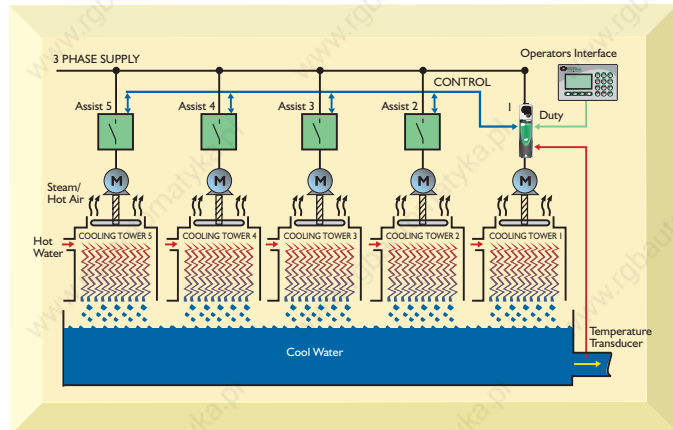

More Features

- Auto-changeover to ensure starters are not continually running for long periods of time
- Assists number of starts per hour protection (selectable)
- Assist Override delay to react to peak demands (selectable)
- All data entry for set-up in engineering units

Accessories

- Fieldbus communication options:
Modbus, DeviceNet, PROFIBUS DP, INTERBUS and CTNet
- Expanded I/O option
- CTNet Modular I/O
- Range of HMI's
- Dynamic Braking
- Regenerative Braking

Solutions Software	Order Code
Fan and Pump Duty Assist	SSP-4000-0030

Unidrive Secure Disable Function

Overview

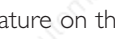
The Secure Disable feature on the Unidrive  AC allows the drive output to be disabled so that the drive cannot generate torque in the motor. Secure Disable also provides a normal “enable” input to the drive, and can be used in the same way.

A +24V logic level must be applied in order to enable the drive power functions. However the internal circuitry has been designed using in-depth fail safe approved techniques and principles so that no single fault or component failure can cause a disabled drive to produce motor shaft torque. Only in extremely unlikely combinations of faults could this function be defeated. Secure Disable can therefore be used in safety-related applications to prevent unintended operation of the motor:

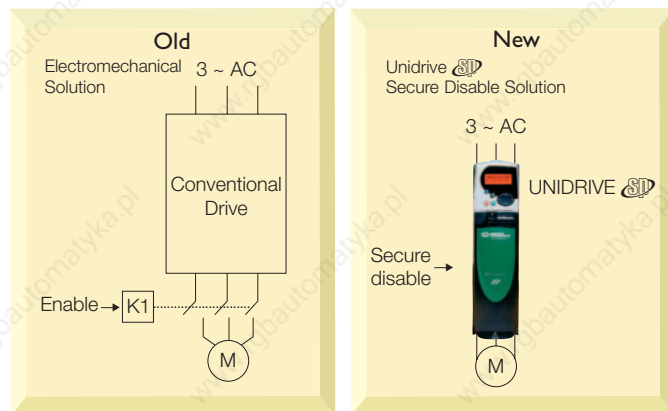

Figure 1: The Secure Disable function can take the place of control gear, saving components and space for the same level of security

The reliability of the Secure Disable function is superior to that offered by virtually any single channel electromechanical device such as a contactor. It is like having a special highly reliable contactor built in to the drive output, but there are no moving parts, no extra cost, and no special requirements for preventing the contactor from opening on load. It offers the possibility of eliminating contactors, including special safety contactors, from systems where the prevention of movement is important to prevent safety hazards or expensive damage.

Special note on emergency stop functions

To avoid misunderstandings it is important to make clear the purpose of the Secure Disable function. It has the ability on request to prevent unintended operation of the motor, with a very high level of integrity, i.e. despite the occurrence of faulty components. This is intended to be used in the normal range of functions of a machine, to prevent unexpected movement when this might cause a hazard. For example, a “safeguard” or “interlock” system might be provided so that when a guard is open and an operator might be within the area protected by the guard, operation of the drives within that area is inhibited. This could be a normal and frequent condition of the machine, so that a failure to inhibit the drive could be quite likely to result in serious injury.

In general, Secure Disable is not intended to provide an emergency stop function. The requirement for an emergency stop is different from a safeguard. The emergency stop is not specifically a very high integrity function, because it is not intended to be used routinely to ensure personal safety. It is intended to provide a simple over-riding method for completely removing power to all actuators in the event of an unforeseen hazardous situation, regardless of the state of the machine. It is used when the intended, designed safety provisions and operating rules of the machines have failed, and an operator realises that a hazardous situation has occurred. According to standards such as EN 60204-1 (Europe), IEC 60204-1 (International) and NFPA 79 (U.S.A.), the final removal of power for emergency stop must be carried out by hard-wired electromechanical components. The use of Secure Disable alone will not fulfil this requirement.



Important Warning

The design of safety-related systems requires specialist knowledge. To ensure that a complete system is safe requires an overall risk assessment. The use of Secure Disable and other equipment intended for safety-related applications does not of itself ensure safety. They must be correctly incorporated into the complete design.



The information in this publication gives guidance on the use of Unidrive  Secure Disable, and also some general background material on the design of safety-related systems. This information is believed to be correct and to reflect accepted practice at the time of writing. However it is the responsibility of the designer of the end product or application to ensure that it is safe and in compliance with relevant regulations.

SECURE DISABLE APPLICATIONS

As well as in conventional non-safety-related applications, Secure Disable can also be used in any position where contactors with connected movement are used to achieve safe disable.

Case 1 – Simple stop/start control to EN 954-1 Cat I

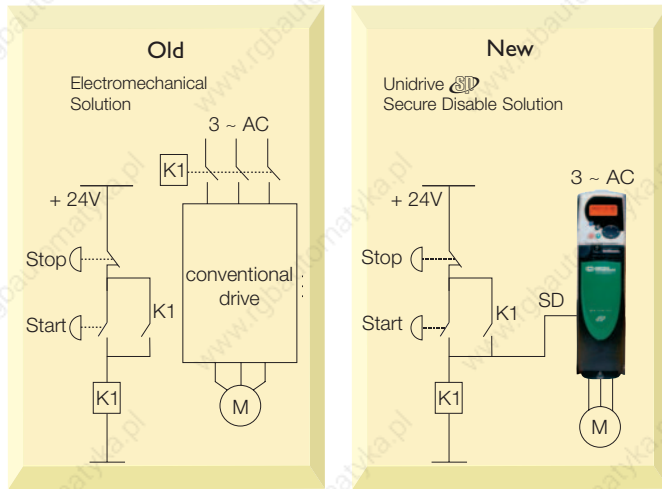

The benefits of using Secure Disable on the Unidrive SD are:

- Power contactor replaced by a signal relay (cost and space saving)
- Drive can now have power applied continuously, so that its auxiliary functions remain active
- 24V DC logic supply can be taken from the drive, eliminating an external supply (cost and space saving)

Case 2 – Interlock (previously with feedback) to EN 954-1 Cat 2

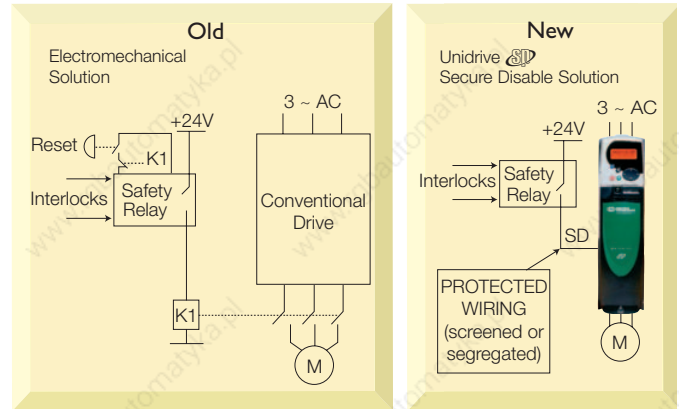

The failure mode where the relay closes (or stays closed) when not energised no longer exists, so the feedback contact is not required. The enable input wiring has to be protected in order to avoid the possibility of a short circuit to positive d.c. supply or digital logic signal which could cause inadvertent enable. Protection is achieved either by ensuring physical separation from all other circuits or else by the use of a cable with an earthed screen so that a short circuit always results in an earth fault and a loss of the logic signal (see EN ISO 13849-2).

The benefits of using Secure Disable are:

- Power contactor (with connected movement) eliminated (cost and space saving)
- Feedback checking arrangement eliminated
- No need for drive early-disable arrangement

The additional cost of arranging protected wiring for the drive enable input is small compared with these benefits.

Case 3 – Fail safe interlock (previously with feedback) to EN 945-1 Cat 3

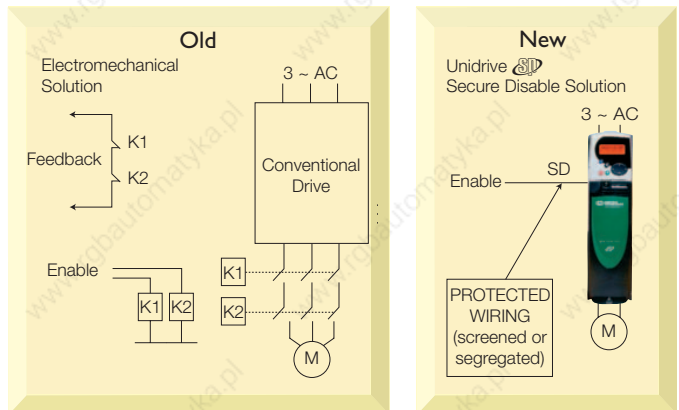

Again the failure mode where a relay closes (or stays closed) when not energised no longer exists, so the feedback contacts are not required. This also means that in order to achieve EN 954-1 category 3 it is no longer necessary to provide two channels for interrupting the power; because no single faults cause the motor to be driven. As in the previous case, the enable input wiring has to be protected in order to avoid the possibility of a short circuit to a positive d.c. supply or digital logic signal which could cause inadvertent enable.

The benefits of using Secure Disable are:

- Two power contactors with connected movement eliminated (cost and space saving)
- Feedback checking arrangement eliminated
- No need for drive early-disable arrangements

Again the additional cost of arranging protected wiring for the drive enable input is small compared with these benefits.

Category 4 applications EN 954-1

Secure Disable alone meets the requirements of category 3. It can form part of a category 4 application. The additional requirements are:

- A further channel for inhibiting motor operation in the event of an accumulation of faults, for example a contactor with contacts having connected movement and a test arrangement
- A method for testing that Secure Disable is intact. This can be done by testing that no voltage is present at the SD input, since the only credible failure modes result in voltage appearing at that point. The test can be done by a conventional relay, but that relay must itself be tested

For an electromechanical system, the arrangement is the same as for case 3. The difference from category 3 application is the degree of checking in the control circuit which provides the two inhibit channels.

Case 4 shows a possible arrangement. "Feedback 1" is used in the same way as for the electromechanical systems, allowing a test of the safety function whenever the control relay (or other control circuit) is reset. "Feedback 2" is used to test the monitoring relay, for example it may be included to latch in a start circuit so that if the relay does not operate the circuit fails to latch. In an electronic control system, this feedback could be provided by a logic input on the controller.

Case 4 – Secure Disable used in EN 954-1 Cat 4 applications

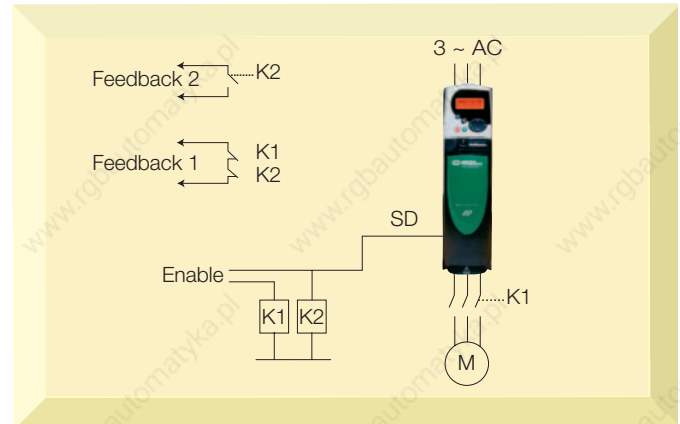

The benefits of Secure Disable are:

- Power contactor with connected movement replaced by relay or controller logic input (cost and space saving)
- No need for drive early-disable arrangement

Provision of electronic braking for rapid stop.

The drive is capable of active braking through the motor; but this not a high-integrity function. Where braking is desirable, such as in an emergency stop function, but the actual safety function is the removal of power from the motor; a time delay is required between instructing the drive to stop and then disabling it.

A fail-safe time delay relay can be used for this function, such as shown in Case 5. Safety relay ranges include relay expansion units with a delay feature. In this arrangement the drive brakes as soon as the gate is opened, and is disabled securely after the delay relay de-energises.

It must be emphasised that if braking is itself a safety requirement, i.e. if the braking does not operate then there is an unacceptable risk of injury, then a fail-safe brake must be provided, such as a mechanical brake with electrical hold-off.

Case 5 – Provision of braking through the drive

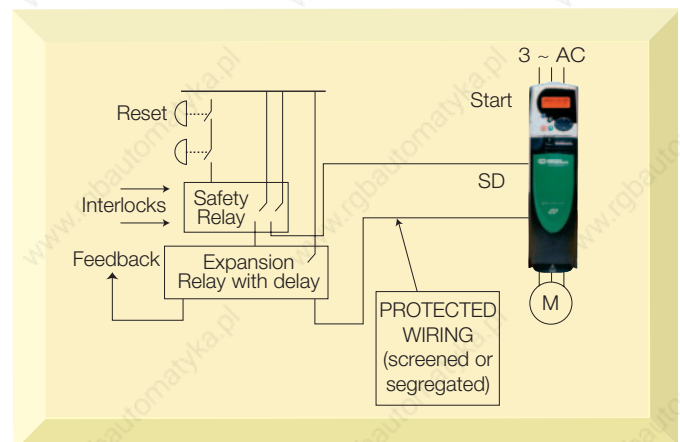

USE OF SECURE DISABLE FUNCTION IN ELEVATORS TO EN 81-1: 1998

The Secure Disable function in Unidrive  provides a highly secure method for preventing the motor from being driven when the enable signal is absent. It can be used in place of one of the two output contactors normally used for this purpose in an elevator drive, giving conformity to European standard EN 81-1:1998 and providing savings in space, cost and maintenance requirements.

This guide explains how to incorporate the drive into an elevator control system, which is assumed to conform to EN 81-1 with the use of two contactors, and to enable one contactor to be eliminated.

The guide does not apply to Unidrive  manufactured before 2005. Anyone wishing to use this function please refer to your local Drive Centre to confirm drive serial numbers with EN 81-1 compliant control circuits.

Connecting the safety-related circuits

Figure 1 illustrates in general terms the existing system with a drive without Secure Disable.

Figure 1: Safety interface for existing controller with two contactors

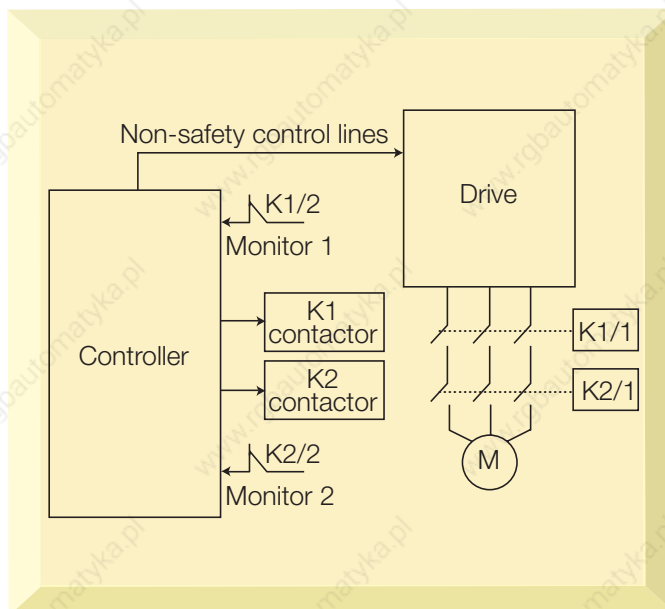



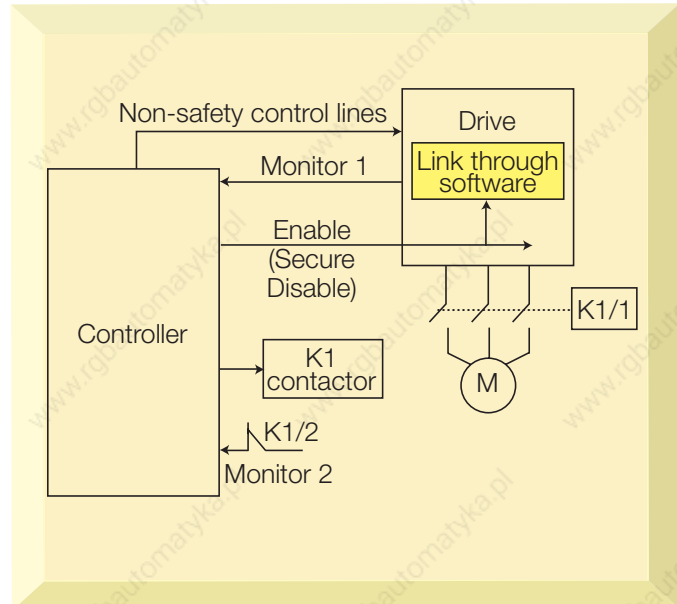

Figure 2 shows how the system can be changed to use Unidrive  with a single contactor.

Figure 2: Safety interface for Unidrive  with one contactor



The controller output which previously operated contactor K1 now controls the drive enable input (Secure Disable). The feedback for this channel is provided by a digital output from the drive which is programmed to monitor the "enabled" parameter. This interface can be through 24VDC logic levels or through an interposing relay, as required by the controller design.

To program the digital output, refer to section 11 and menu 8 of the Unidrive  User Guide.

Parameter 8.09 is the state of the enable input. Any of the digital outputs or input/outputs can be programmed to reflect 8.09 by using their source pointers to point to 8.09. The inversion function should be set so that the digital output is high when the enable input is low. This gives the same sense as the original auxiliary contact, and ensures that the more common faults such as broken wires and earth faults in this circuit result in a fault indication to the controller.

If an interposing relay is used then it should have normally open contacts, so that the more likely fault in the relay, non-operation, results in a fault indication to the controller.

Although not required for conformity with EN 81-1, if the controller is of the programmable type then the correct functioning of the "Monitor 1" drive digital output can be monitored by checking that it goes low when the drive is enabled, as well as going high when the drive is disabled. If it fails to go low then the monitor circuit is not healthy and the elevator operation should be prevented at the next opportunity.

Environmental protection

The drive must be protected from condensation and electrically conductive contamination. In exterior elevator control rooms subject to rapid temperature and humidity cycles some form of anti-condensation heating must be used.

Independent verification to EN 81-1:1998

Provided that the controller with two contactors as shown in Figure 1 was in conformity with EN 81-1 12.7.3 method a), the system shown in Figure 2 will also conform to EN 81-1 12.7.3 method b).

The recommended arrangement, including this guidance note, have been approved by TÜV as conforming to the requirements of EN 81-1:1998 for interruption of the supply to the motor.

The Secure Disable function has no failure modes which could result in an unexpected output to the motor, other than modes which are excluded in Annex H of EN 81-1:1998. In this respect it is superior to the contactor, which has a relatively high probability of sticking closed and relies upon the auxiliary contact and second contactor to ensure safety in this case.

The monitor circuit uses complex hardware and software. Since it might fail in an undetected (high) state, it is recommended that either automatic checking is used within the controller, or else a manual check is carried out during routine maintenance. The check should confirm that the output goes low when the drive is enabled.

A failure of the monitor circuit does not cause the system to become unsafe.



ELECTROMAGNETIC COMPATIBILITY

Elevator requirements within the European Union are:

EN 12015:1998 Emission

EN 12016:1998 Immunity

The 1998 versions are current at the time of publication of this guide (December 2004). Revised versions are expected to be published early in 2005 (see below).

The emission limits in EN 12015:1998 are similar to EN 61000-6-4, which is met by Unidrive  when using the recommended optional input filter and screened motor cable. Full instructions are given in the Unidrive  EMC data sheet.

Particular notice must be taken of the recommendations where a device such as the output contactor must be included in the motor circuit. The EMC data sheet gives recommendations for managing this situation, which must be followed carefully. The output contactor and any associated unscreened wiring, and the contactor coil wiring, must be kept well spaced from the input wiring to the filter; otherwise stray capacitive coupling will cause increased high-frequency emission from the power input wiring.

Unidrive  meets the requirements of EN 12016 unconditionally.

Future revisions of EN 12015 and EN 12016

Please refer to your local Drive Centre/Distributor for information regarding EN 12015:2005 and EN 12016:2004.



Unidrive

LOW VOLTAGE DC OPERATION

Introduction

Note: To design a system to operate from 48-96VDC, please read "Application Note: Low Voltage DC Operation" available as a download from controltechniques.com.

Principles of Operation

The Unidrive  is normally operated from a 3-phase AC supply (200V, 400V etc.) or a DC supply of the equivalent rectified voltage. This provides power for all control circuits via the SMPS (Switch Mode Power Supply), and power for the motor via the inverter. Instead of powering the drive from a 3-phase AC supply it is also possible to operate the Unidrive  from an external low voltage DC supply, the supply voltage is dependant on the drive frame size as detailed in the table below.

Drive size	Nominal continuous applied low voltage DC
1	48
2	48-72
3	48-72
4	48-96*
5-9	48-96

*Size 4 low voltage drives have a nominal continuous applied low voltage of 48V.

It is possible under certain circumstances for the Low voltage DC to be higher than the above stated values, for example if regen energy is allowed a return path to the supply, the DC level would rise.

Note that this method of drive operation will be referred to as Low Voltage DC operation through the remainder of this document.

For low voltage DC operation, as well as the main low voltage DC supply the following external supplies are required.

For all Unidrive , a 24VDC supply must be connected to the +24V external input on the green control terminal block of the drive. This supplies the control circuitry and may be connected permanently.

For Unidrive SP4 to 9 a 24VDC external supply needs to be connected to the battery mode enable on the drive. (This supply is in addition to the +24V external input).

Advantages of low voltage DC operation

Low voltage DC operation is intended to allow for motor operation in an emergency back-up situation following failure of the AC supply, for example in elevators, or to limit the motor speed of servo motors during commissioning of equipment, for example a robot cell.

Even though low voltage DC operation is intended for an emergency back-up situation, it is also possible to run the drive permanently in this mode. In the case were the low voltage DC power supply is in the form of a battery the length of time that the drive will run is limited by the battery capacity.

Operating modes

Low voltage DC operation can be used in any of the following modes:

1. Open loop mode

- Open loop vector
- Fixed V/F mode (V/Hz)
- Quadratic V/F mode (V/Hz)

2. Closed loop vector

3. Servo

Low voltage DC operation speed limitation



Low Voltage DC operation CANNOT be used to limit the speed of an induction motor.



The drive can only provide rated torque at low speeds as described above. It is very important to consider this when operating with an overhauling load such as elevator applications, where even with the correct braking resistor selection, the drive may not be able to maintain control of the load if the drive goes into field weakening.

When set up for low voltage DC operation, the drive can provide rated torque to the motor at low speeds. The maximum speed that can be achieved whilst operating from this supply is dependent on the type of motor connected to the drive.

Operation with an induction motor

When operating with an induction motor the drive will effectively start to field weaken at the point that the output voltage requirement (based on the programmed V/F) reaches the maximum that the DC bus voltage of the drive can support (about 34V based on a DC bus of 48V). e.g. The drive would begin to field weaken the motor at around 4Hz for a 50Hz 400V motor.

The drive may continue to rotate the motor up to base speed. However, even with no external load (just a bare motor shaft) the motor could stall due to the reduced torque available whilst so far into field weakening.

Be aware that reduced torque may be experienced in instances where the motor requires significant volts to magnetise; the reasons for this are:

- The external low voltage DC power supply has reached the maximum supply voltage to the drive
- The drive has reached the maximum allowable output voltage available in this mode of operation

Operation with a servo motor



When in Low Voltage DC operation the Unidrive  may NOT be able to limit the speed of a servo motor with an overhauling load.



If a permanent magnet motor is made to rotate at a high enough speed by an external torque, the DC bus of the drive and its associated wiring could rise above 48V.

The speed of the motor is limited based on the k_e of the motor: e.g. with a 3,000rpm Unimotor (with a k_e of 98.0V/krpm), a 48V DC bus would allow a motor speed of up to around 347rpm.

RATINGS

Drive output current ratings

The table below shows the maximum continuous output currents of the individual drives, current de-rating may need to be considered under certain conditions. See the Technical Data chapter of the Unidrive  User Guide for full details.

Maximum continuous output current (200V drives)

Model	FLC (A) Normal Duty	Model	FLC (A) Normal Duty
SP1201	5.2	SP3201	42
SP1202	6.8	SP3202	54
SP1203	9.6	SP4201	68
SP1204	11	SP4202	80
SP2201	15.5	SP4203	104
SP2202	22		
SP2203	28		

Maximum continuous output current (400V drives)

Model	FLC (A) Normal Duty	Model	FLC (A) Normal Duty
SP1401	2.8	SP5401	138
SP1402	3.8	SP5402	168
SP1403	5.0	SP6401	202
SP1404	6.9	SP6402	236
SP1405	8.8	SP7411	202
SP1406	11	SP7412	236
SP2401	15.3	SP7413	290
SP2402	21	SP7414	350
SP2403	29	SP8411	440
SP2404	29	SP8412	540
SP3401	35	SP8413	620
SP3402	43	SP9411	700
SP3403	56	SP9412	770
SP4401	68	SP9413	850
SP4402	83	SP9414	990
SP4403	104	SP9415	1150

Maximum continuous output current (575V drives)

Model	FLC (A) Normal Duty	Model	FLC (A) Normal Duty
SP3501	5.4	SP6601 [Ⓢ]	125
SP3502	6.1	SP6602 [Ⓢ]	144
SP3503	8.3	SP7611 [Ⓢ]	125
SP3504	11	SP7612 [Ⓢ]	144
SP3505	16	SP7613 [Ⓢ]	168
SP3506	22	SP7614 [Ⓢ]	192
SP3507	27	SP8611 [Ⓢ]	274
SP4603 [Ⓢ]	36	SP8612 [Ⓢ]	341
SP4604 [Ⓢ]	43	SP9611 [Ⓢ]	428
SP4605 [Ⓢ]	52	SP9612 [Ⓢ]	483
SP4606 [Ⓢ]	62	SP9613 [Ⓢ]	505
SP5601 [Ⓢ]	84	SP9614 [Ⓢ]	637
SP5602 [Ⓢ]	99	SP9615 [Ⓢ]	705

Maximum continuous output current (690V drives)

Model	FLC (A) Normal Duty	Model	FLC (A) Normal Duty
SP4601	22	SP7613	168
SP4602	27	SP7614	192
SP4603	36	SP8611	208
SP4604	43	SP8612	263
SP4605	52	SP8613	331
SP4606	62	SP9611	374
SP5601	84	SP9612	429
SP5602	99	SP9613	478
SP6601	125	SP9614	526
SP6602	144	SP9615	591
SP7611	125	SP9616	655
SP7612	144		

Ⓢ The same model can be used on a 575V or a 690V supply, and has two different output ratings. For example: At Normal Duty, SP4603 is suitable for a 22kW output motor on a 575V supply, and a 30kW output motor on a 690V supply.

Low voltage DC rating

On all but size 1, the nominal low voltage DC supply level is set by the user in Pr 6.46.

On the size 1 drive this value is non adjustable, however on sizes 2 and above the parameter can be set to the value decided by the user but within the limits as set out below.

The default setting is 48V for all the drive sizes. The over voltage trip threshold and braking IGBT turn on voltage are scaled from this value as follows:

- Brake IGBT turn on = 1.325 × Pr 6.46 (V)
- Over voltage trip = 1.45 × Pr 6.46 (V)

Model	Minimum continuous operating voltage (V)	Minimum start up voltage (V)	Nominal continuous operating voltage (V) (Pr6.46)	Maximum braking IGBT turn on voltage (V)	Maximum over voltage trip threshold (V)	Required current rating of low voltage DC supply (A)
SP1	36	40	48	63.6	69.6	2 x drive output current (heavy duty current rating)
SP2	36	40	48-72*	95.4	104.4	
SP3	36	40	48-72*	95.4	104.4	
SP4	36	N/A	48-96**	127.2	139.2	
SP5	36	N/A	48-96*	127.2	139.2	
SP6	36	N/A	48-96*	127.2	139.2	
SP7	36	N/A	48-96*	127.2	139.2	

* Dependant on the setting of Pr 6.46 as discussed earlier.

** Size 4 low voltage drives have a nominal continuous applied low voltage of 48V.

For larger drives please consult your local Drive Centre

Minimum and maximum voltage values include ripple and noise.

Ripple and noise levels must not exceed 5%.

Model	Maximum continuous operating voltage (V)	Minimum continuous operating voltage	Nominal continuous Operating voltage (V)	Minimum start up voltage (V)
All SP	30	19.2	24	21.6

Minimum and maximum voltage values include ripple and noise.

Ripple and noise levels must not exceed 5%.

24V battery mode enable rating

The table below shows the specification of the 24V battery mode enable terminal that the user supply should meet.

Model	Maximum continuous operating voltage (V)	Minimum continuous operating voltage	Nominal continuous Operating voltage (V)	Current consumption
SP 1-3	N/A	N/A	N/A	N/A
SP 4-7	30	19.2	24	>470mA

Minimum and maximum voltage values include ripple and noise.

Ripple and noise levels must not exceed 5%.

Mentor II

Solutions Platform

DC Drive

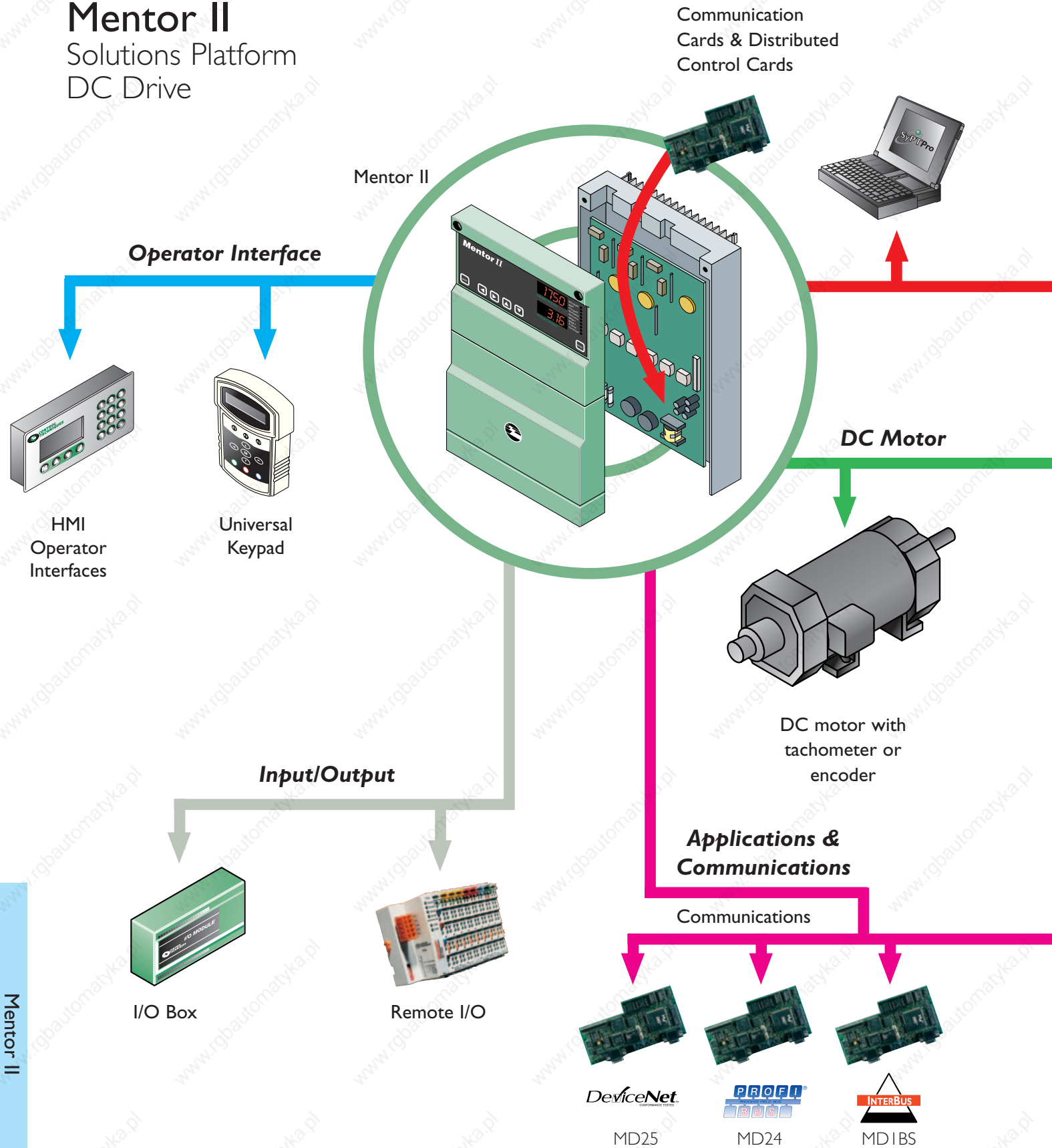

Typical Applications

Extruder

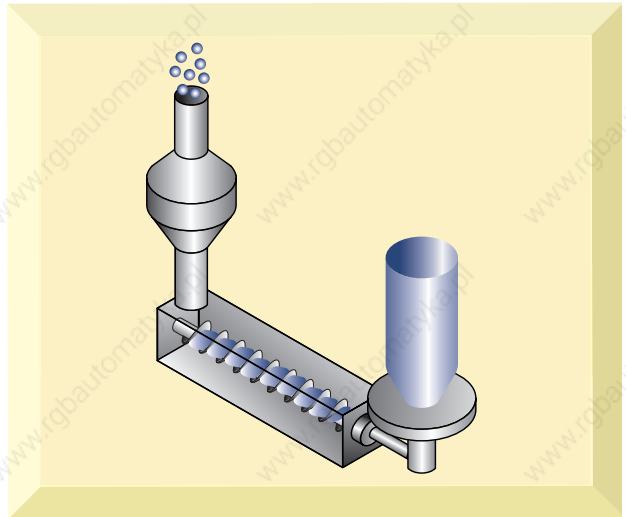

Cooling Rolls

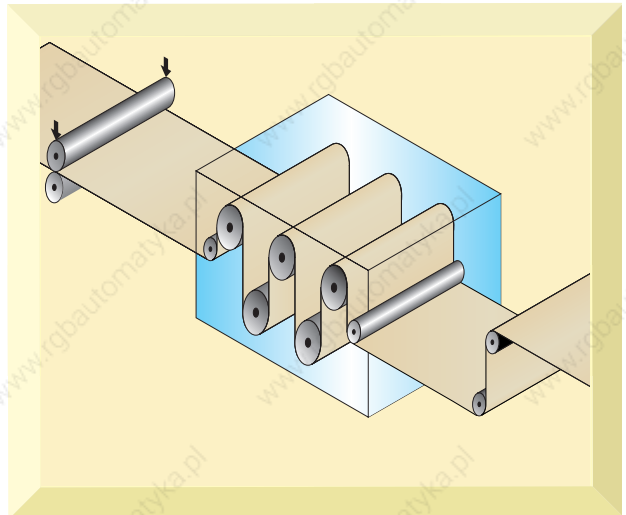

Turret Rewind

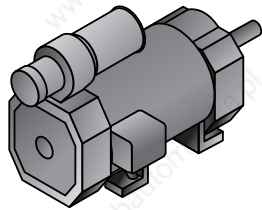
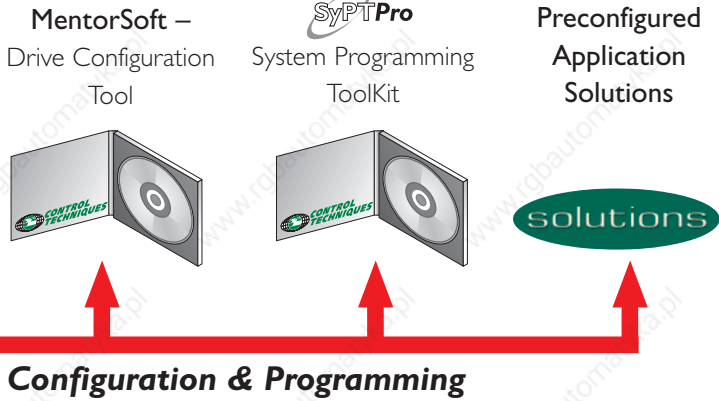
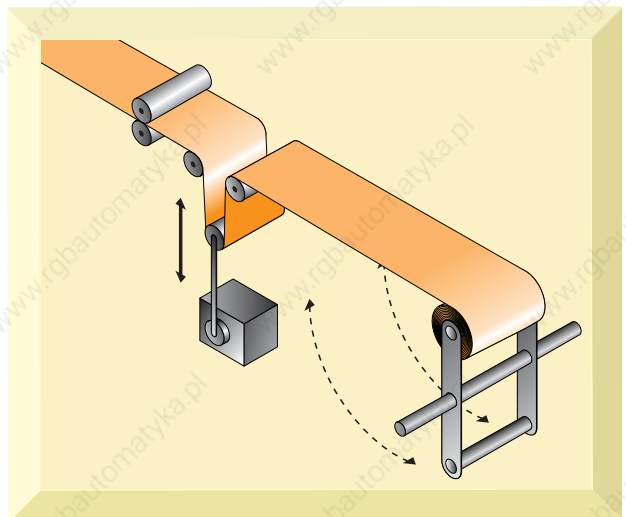

DC motor

Applications

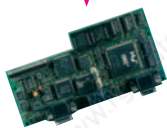

Applications Modbus RTU MD29

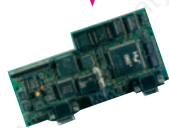

Applications Modbus RTU MD29AN

Mentor II

The Intelligent Drive

OVERVIEW

DC drives are widely used in applications that require regeneration, precise speed control, dynamic performance, and constant torque over wide speed ranges. The Mentor II delivers the universal DC drive solution.

Simple stand-alone applications are easily configured to control motor speed, voltage or current using standard internal settings. Set-up is convenient using the drive keypad, CTKP remote keypad, or MentorSoft, a Windows™ based drive configuration tool. The Mentor II has extensive diagnostic and communication abilities that enhance system reliability. The drive's standard yet powerful microprocessor is a versatile system component that can eliminate the need for a PLC with integral functions such as thresholds, timers and logic gates that perform basic control.

The simple addition of the MD29, a 32-bit application co-processor card, provides high performance drive systems with local intelligence for true distributed control. The MD29 enables users to incorporate custom or proprietary process control application programs to their drive. The Mentor II also provides a wide range of communication protocol options.

Mentor II systems have proven to be extremely reliable and are ideally suited to web handling, winders, slitters, extruders, wire drawing, converting lines, and plastics production. The Mentor II's integrated design and highly programmable features make it an ideal choice for OEMs and System Integrators, as well as replacement or retrofit drives for End Users.

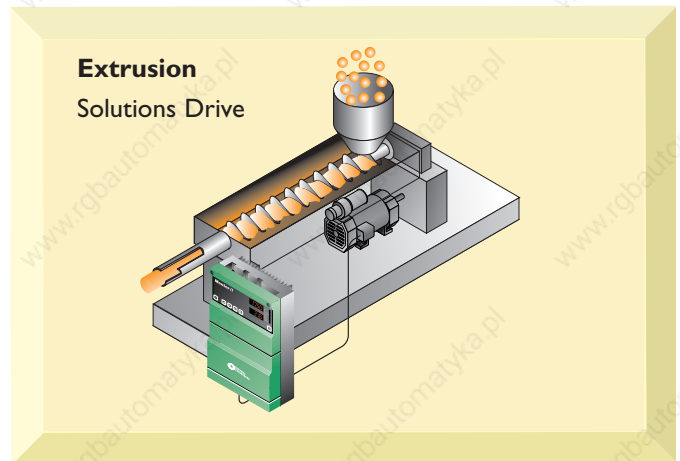

- **Microprocessor based Digital DC Drive**
- **5.5 to 750 kW, 3 phase, 208 to 660 VAC**
- **Regenerative and non-regenerative models**
- **RS485 serial communications**
- **Extensive fieldbus communication capabilities**
- **Plug-in 32-bit application co-processor card (MD29 and MD29AN)**
- **MentorSoft Windows-based drive configuration tool**



FEATURE PERFORMANCE

Accepts wide range of supply voltage (208 to 660 VAC)

Can be applied to worldwide voltages.

Non-regen and regen models share the same footprint

Allows for common mechanical design and mounting.

MentorSoft Windows™ based drive configuration tool

Provides easy programming and diagnostics of the drive.

32-bit application co-processor card (MD29)

Enables customised applications for distributed control system architectures.

PROFIBUS-DP, Modbus RTU, INTERBUS, DeviceNet, and CTNet plug-in communication cards

Communicates on user's preferred network.

Built-in RS485 serial communications

Allows for easy programming and control of drive.

Extensive and configurable analog and digital I/O

Customises drive to specific applications.

Programmable boolean logic (AND, NAND, OR, NOR) gates with delay outputs

Assists with general system interface logic needs, expanding application possibilities.

Programmable threshold comparators

Expands application possibilities by providing a pair of independent numerical comparators with adjustable hysteresis.

Built-in digital lock function for frequency following

Allows accurate master/slave applications.

Accepts DC tachometer and encoder feedback

Enables precise speed control.

Extensive diagnostics and fault indicators

Used for accurate drive system diagnosis.

Order Code	
M	XXX R
	Regen (omit for Non-regen)
	Output Current
	Mentor II Product Family

RATINGS

THREE PHASE INPUT

5.5 to 340kW (208-230 VAC);

7.5 to 750kW (380-460 VAC) Special Order (525 & 660 VAC)

208 / 240 VAC +/- 10%					
Motor kW	Output Current (A) @40°C	Output Current (A) @55°C	Field Output Current	Non-Regen Order Code	Regen Order Code
5.5	25	20	8A Current Regulated	M25	M25R
7.5	45	38		M45	M45R
11	75	55		M75	M75R
18.75	105	89		M105	M105R
22	155	125	10A Fixed Voltage ①	M155	M155R
30	210	172		M210	M210R
56	350	255		M350	M350R
75	420	338		M420	M350R
100	550	428		M550	M550R
125	700	508		M700	M700R
175	825	675	20A Fixed Voltage ①	M825	M825R
200	900	820		M900	M900R
260	1200	1150		M1200	M1200R
340	1850	1620		M1850	M1850R

380 / 480 VAC +/- 10%					
Motor kW	Output Current (A) @40°C	Output Current (A) @55°C	Field Output Current	Non-Regen Order Code	Regen Order Code
7.5	25	20	8A Current Regulated	M25	M25R
15	45	38		M45	M45R
30	75	55		M75	M75R
37.5	105	89		M105	M105R
56	155	125	10A Fixed Voltage ①	M155	M155R
75	210	172		M210	M210R
125	350	255		M350	M350R
150	420	338		M420	M350R
200	550	428		M550	M550R
250	700	508		M700	M700R
300	825	675	20A Fixed Voltage ①	M825	M825R
340	900	820		M900	M900R
450	1200	1150		M1200	M1200R
750	1850	1620		M1850	M1850R

① For field control, add external field regulator.

TERMINAL DIAGRAM

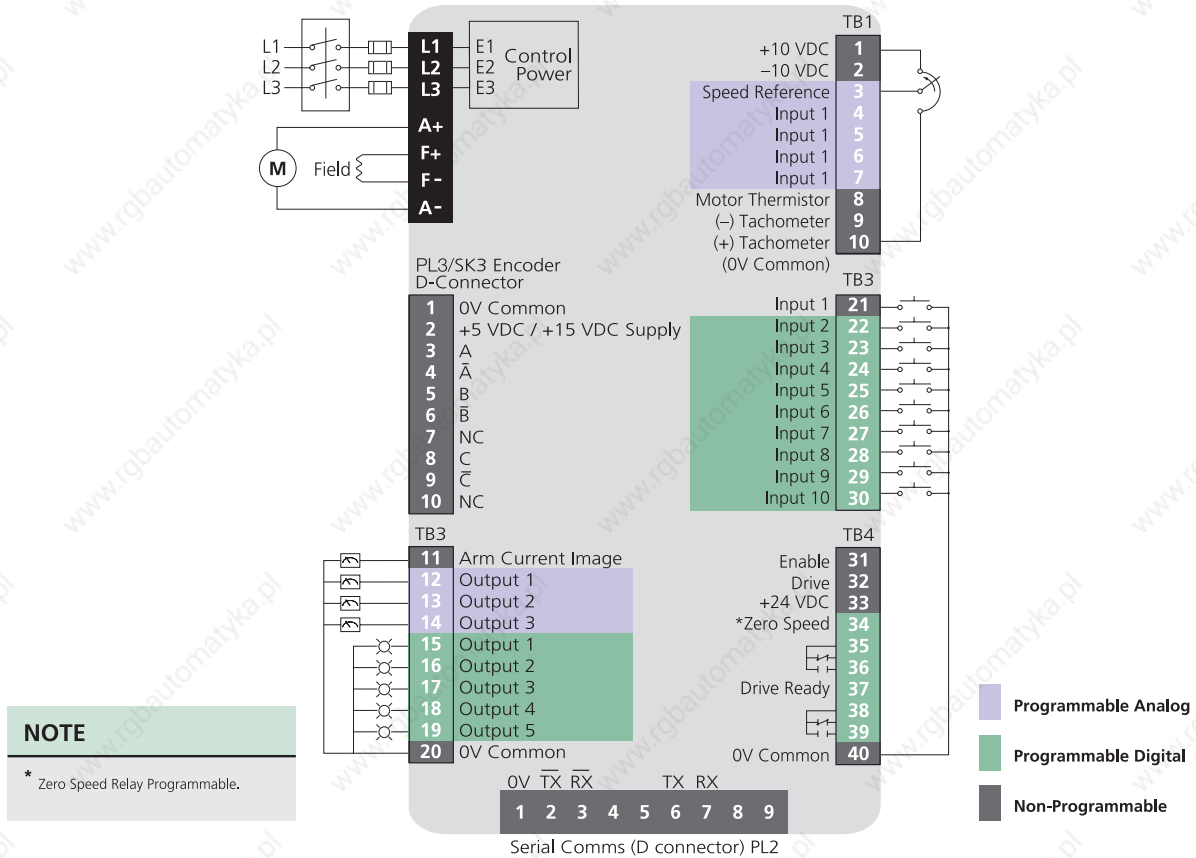

TERMINAL DESCRIPTION

Pin#	Function	Type/Description	Notes	Pin#	Function ①	Type/Description	Notes
1	+10VDC	Reference Supply	10 mA max	20	0V Common	Circuit Common	
2	-10VDC			21	F1 (Run Permit)	Digital Input	+24VDC, 10k Ohms
3	Speed Reference	Analog Input, 12 bit	± 10 VDC, 100k Ohms or 4-20 mA, 100 Ohms	22	F2 (Inch / Jog Reverse)	Digital Input	+24VDC, 10k Ohms
4	Analog Input GP/	Analog Input Bi-polar, 10 bit + sign	± 10 VDC, 100k Ohms	23	F3 (Inch / Jog Forward)		
5	GP 2			24	F4 (Run Reverse (latched))		
6	GP 3			25	F5 (Run Forward (latched))		
7	GP 4			26	Digital Input F6		
8	Motor Thermistor 1.8k Ohm reset level	Analog Input	3k Ohms trip point,	27	F7		
9	DC Tachometer (-)	Analog Input		28	F8		
10	DC Tachometer (+)	Circuit Common		29	F9		
11	Armature Current Image	Analog Output	6.6VDC @ 150% current	30	F10		
12	Analog Output DAC 1	Analog Output Bi-polar, 10 bit + sign	± 10 VDC, 5 mA	31	Drive Enable		
13	DAC 2			32	Reset	Digital Input	Fault Reset
14	DAC 3			33	+24VDC Supply	User Supply	200 mA max
15	Digital Output ST 1	Digital Output Open Collector	+24VDC, 100 mA	34	Form C Status Relay (Zero Speed)	Relay Common	250VAC, 2.2A
16	ST 2			35		N. C. Contact	110 VAC, 5A
17	ST 3			36		N. O. Contact	5VDC, 5A
18	ST 4			37	Form C Status Relay (Drive Ready)	Relay Common	250VAC, 2.2A
19	ST 5			38		N. C. Contact	110 VAC, 5A
				39		N. O. Contact	5VDC, 5A
				40	0V Common	Circuit Common	

Programmable Analog Programmable Digital All Analog I/O is scalable

SPECIFICATION

Environment

Ambient Operating Temperature	0 to 40°C Derate current 1.5% per °C to 55°C
Cooling Method	Convection and forced convection, model dependent
Humidity	95% non-condensing at 40°C
Storage Temperature	-40 to 55°C
Altitude	0 to 4000m Derate 1% per 100m between 1000m and 4000m
Enclosure	Chassis (IP00)

AC Supply Requirements

Voltage	208 to 480 VAC -5%, +10% 525/575/660 VAC ±10% (Optional M350 and above)
Phase	3Ø
Frequency	45 to 62 Hz
Efficiency	98%

Control

Feedback Methods	Armature Voltage (resolution 0.83 volts) DC Tachometer (resolution 0.1%) Encoder (resolution .01%)
Field Control	Current regulated 8 Amps max (M210/M210R and smaller) Voltage regulated .675 or .9 X Line-to-line voltage (M350/M350R and larger)
Analog Input Resolution	12 bit (Qty 1), 10 bit (Qty 4)
Serial Communications	4-wire RS422 or RS485, optically-isolated Protocol is ANSI x 3.28-2.5-A4 Baud rate is 4800 or 9600

Protection

AC Line Undervoltage Trip	180 VAC
MOV Voltage Transient Protection	Input transient suppression
Instantaneous Overcurrent Trip	300% armature current
Armature Open Circuit	Armature circuit is open
Drive Overload Trip	Inverse time, 150% for 30 seconds
Phase Loss Trip	Loss of input phase
Overtemperature Trip	Heatsink exceeds 100°C
Motor Thermal Trip	Motor over-temp switch or Thermistor
Feedback Loss	Loss of motor feedback
Feedback Reversal	Tachometer or Encoder wired backwards
Field Loss	No field current
Field On	Field current during auto-tune
Field Overcurrent	Field current greater than field demand
Current Loop Loss	Loss of 4-20 mA reference
External Power Supply	Short circuit on +24VDC user power supply
Power Supply	Internal power supply out of tolerance
Serial Communications	Mode 3 serial comms data loss Loss
Processor 1	Main control processor fault Watchdog lap
Processor 2	Second control processor fault (MD29)
Watchdog Trip	

Hardware Fault	Hardware malfunction on control board
Memory Fault	Stored parameter checksum fault
External Trip	User interlock fault (programmed)
Software Fault (A29)	MD29 software fault

Approvals & Listings

UL, cUL	File #E58592 Vol. 5C Section I
CE	Designed for marking
ISO 9001:2000	Certified Manufacturing Facility
ISO 14001	Certified Manufacturing Facility

DIMENSIONS (mm)



Order Code	Size* (mm)			Approx. Weight (kg)
	H	W	D	
M25, M45, M75	370	250	150	10
M25R, M45R, M75R	370	250	150	11
M105	370	250	197	14
M105R	370	250	197	15
M155, M210, M155R, M210R	370	250	197	21
M350	405	450	280	22
M350R	405	450	280	23
M420, M550	423	450	280	22
M420R, M550R	423	450	280	23
M700, M825	423	450	280	27
M700R, M825R	423	450	280	30
M900, M1200, M1850	1045	450	510	70
M900R, M1200R, M1850R	1505	450	510	120

* Approximate, not to be used for construction purposes.
For complete drawings consult product manual. or download from www.controltechniques.com/download.htm

MENTOR II OPTIONS

Control Techniques offers an extensive selection of option cards for use with our high performance Mentor II. The option cards install easily, with no tools required. Our I/O, feedback, memory, communication and application options enable you to upgrade the performance of your drive to meet the specific demands of your application.

Configuration of the Mentor II is simplified, using the keypad or MentorSoft, our complimentary Windows based drive set-up tool. With so much flexibility at your command, Control Techniques gives you the options you need to set up Mentor II the way you want it.

Options

Option	Description	Order Code
Drive Configuration Programming	Drive Configuration Tool	MentorSoft
Operator Interface	Universal Keypad	Universal Keypad
	Operator Interface Units	See section 12.3
Input/Output	I/O Box	CT I/O Box
	Remote Network I/O Beckloff	SSP7200-RerD
Field Regulation	FXM Field Regulation Units	FXM5
Communication	PROFIBUS-DP	MD-24
	INTERBUS	MD-1BS
	CTNet	MD-29AN
	DeviceNet	MD-25
	Modbus RTU	MD-29
Application Co-processor	32 bit Co-processor	MD-29
	32 bit Co-processor with CTNet	MD-29AN
Application Programming Software	SyPT Pro – Systems Programming Tool	SyPT Pro
Solutions Software	Dual Mode Winder Preconfigured Application Programs	SSP-4000-0010 Consult Drive Centre

DRIVE CONFIGURATION AND PROGRAMMING

Drive Configuration Tool (MentorSoft)

MentorSoft is a complimentary Windows based drive configuration tool designed to enable the complete control and display of all parameters within Mentor II. Functions within MentorSoft allow data to be uploaded, viewed and saved or retrieved from disk, modified and printed. It can be used off-line in the office or on-line on the plant floor. MentorSoft communicates with the Mentor II via the computer's serial port to the drive's RS485 port using a communications cable.

Some of its many capabilities include:

- Commissioning screen – displays wiring and control logic
- Compare functions – compares current drive configuration with previously stored versions
- User screen – customised by the user with up to 15 key parameters
- Built-in reference manuals and search functions – provide extensive "Help" files for both the drive and the software.

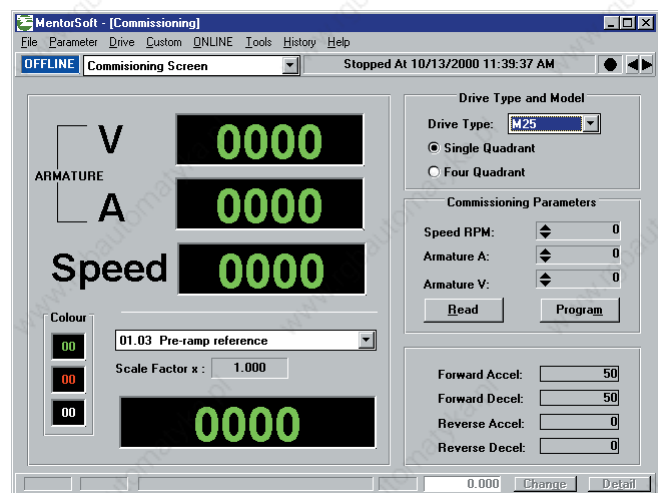
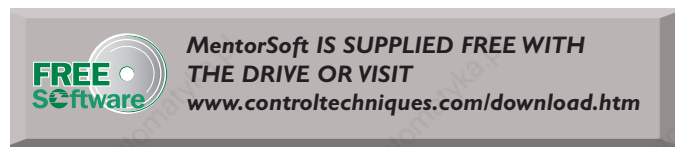

OPERATOR INTERFACE

Universal Keypad

The Universal Keypad is an ideal maintenance tool for use with Commander SE and Mentor II). Five navigation keys and plain text parameter descriptions make the CTKP easy to use for viewing and modifying drive data. The keypad is designed for hand-held or panel mounting. The IP65 rating, screw-down terminals and stress relief for cable connections assure a rugged and robust design.



HMI Operator Interface Unit



HMI 200

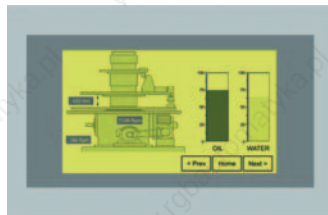

VTI55W



TIU500

The HMI operator interface units incorporate a back-lit LCD display and easy-to-use navigation keys. Using the intuitive “WYSIWYG” page editor, they can be programmed to display a variety of menus, submenus, alarms, fault conditions and other critical information. The HMIs support a range of capabilities including multiple font sizes, real time trends and graphs, scheduling and background programs. They communicate via 2 or 4-wire RS485 and to simplify installation, some HMIs are rated IP54 and require no screw mounting holes.

INPUT/OUTPUT

I/O Box

The I/O Box expands the I/O capabilities of the Mentor II, and is connected to the drive through the MD29 application card using an optically isolated RS485 serial link.

Voltage	110 to 240 VAC \pm 10%
Frequency	48 to 62 Hz
Phase	1 \emptyset
RS485 Interface	Supports binary protocol at data rates up to 38.4kbaud for connection to a single drive
Enclosure	Chassis (IP00)



Quantity	Type / Description	Notes
1	Analog Input (12 bit)	\pm 10VDC, 100k Ohms or 4-20 mA, 100 Ohms
4	Analog Input (10 bit)	\pm 10VDC, 100k Ohms
3	Analog Output (10 bit)	\pm 10VDC, 5 mA
8	Digital Input	+24VDC, 10k Ohms
8	Digital Output	+24VDC, 100 mA (200 mA total for all outputs)

Remote Network I/O

The high-quality Beckhoff I/O system is available for CTNet systems, and includes a SSP7200-Rev C bus coupler and a large variety of snap-on terminal blocks allowing up to 256 digital inputs or outputs and up to 100 analog inputs and outputs per bus coupler. Up to 64 Beckhoff I/O systems can be attached to a CTNet network. I/O points exist as CTNet parameters and can be easily read or written. Cyclic data transfers are also supported for efficient I/O sampling. Contact Control Techniques for details on the wide range of available Beckhoff Remote I/O options.

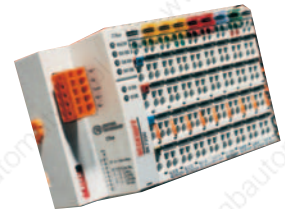

FIELD REGULATION



The FXM5 field regulator is designed to control the field current of DC motors up to 20 amps. When used with the Mentor II variable speed DC drives, the field regulator is controlled directly via the drive parameters. This allows full customization of the field control for any application. The FXM5 can also be used as a stand-alone unit when retrofitting existing applications.

The field regulators is a single phase, controlled thyristor rectifier bridge with a control logic PC board. The bridge can be configured by jumpers to operate in half (single quadrant) or full (two quadrant) control mode.

The FXM5 may be independently controlled by an external reference, or set for automatic field weakening (constant horsepower) or constant field current. Field economy control via contact or logic input and a field loss relay for protection are provided for stand-alone operation. The unit also has a bar graph display (10% increments of the selected range) for field current magnitude.

Order Code	Current (A)	Frequency (Hz)	Input Voltage (VAC)	Output Voltage* (VDC)
FXM5	10/20A	50	220/380/440	198/342/396
		60	240/480	216/432

* Maximum output voltage equals 90% of input rms line voltage. Field current is the controlled variable.

COMMUNICATIONS

The fieldbus interface cards provide high-speed communications using the popular networks and protocol. These networks allow large amounts of data to be transferred quickly to and from network nodes. The RS485 channel is optically isolated (CTNet is transformer isolated) for added protection.

Communications Protocol	Interface Module Catalog Number	System Configuration
PROFIBUS-DP	MD-24	Slave
INTERBUS	MDIBS	Slave
CTNet*	MD-29AN*	Peer-to-peer
DeviceNet	MD-25	Slave
Modbus RTU*	MD29*	Slave

* CTNet and Modbus RTU cards contain full co-processor ability. Refer to Application Co-processor (MD29 and MD29AN) for more information.

Network Communication

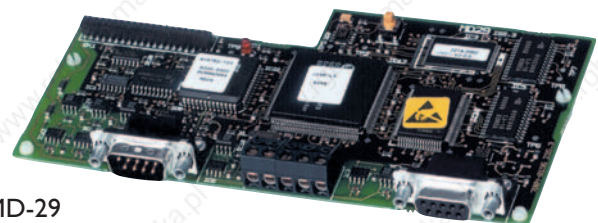
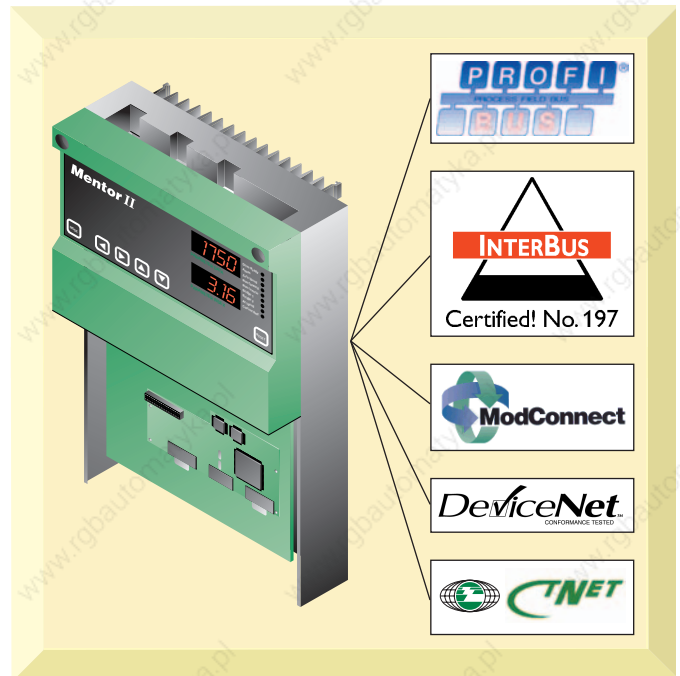

MD-29

APPLICATION CO-PROCESSOR

The MD29 and application cards contain a high-speed microprocessor which provides a low-cost facility for a system designer to write application specific programs without needing a PLC or other stand-alone controller. The add-on cards fit into a 40-pin header within the Mentor II drive. It is programmed (via the RS232 port) using our Control Techniques SyPTPro (System Programming Toolkit) that complies with IEC61131-3 Ladder / Function Block or DPL (Drive Programming Language). In addition to the application co-processor, the MD29AN CTNet card supports peer-to-peer cyclic and broadcast messaging at rates up to 5Mbaud.

The application cards use dual port RAM to provide intimate high-speed bi-directional access. They can read and modify any parameter within the drive, enabling customised real-time calculations under a multi-tasking run-time environment. The high performance microprocessor provides a powerful base for a designer to accomplish complex algorithms for demanding time-critical process control.

The optically isolated RS485 channel serves as a communication port for our CTIU operator interface units. It is fully configurable, supporting multiple communication modes including an ANSI 2 or 4-wire protocol at data rates up to 38.4kbaud. A Modbus protocol with RTU and ASCII slave modes is also available.

32-bit co-processor MD-29

32-bit co-processor with CTNet MD29AN

Typical Pre-configured Application Programs*
S-ramp accel / decel profiling
Digital lock with adjustable ratio control
Spindle orientation
Constant tension, centre wind
PID control for load cell tension or dancer position
Power calculations
Dual Mode Winder Solutions

* Contact your local Control Techniques Drive Centre/Distributor for detailed information on these packages as they are continually evolving. Exact package specifications may vary from one country to another.

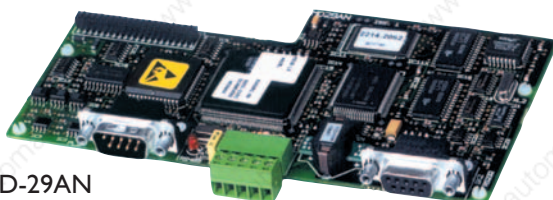

MD-29AN

SyPTPro – System Programming Toolkit

Overview – SyPTPro is the professional drive programming toolkit for OEM's and End Users who wish to maximise the performance of their machines and factory. This IEC61131-3 programming software offers greatly enhanced functionality allowing you to connect drives, operator interfaces and I/O to a network and configure how they exchange data. SyPTPro allow you to program in your choice of three different languages, with a real-time multi-tasking environment. It contains a suite of monitoring and diagnostics features that help you to reduce the time it takes to develop your programmes and allows you to get your machine into service faster.

SyPTPro may also be used to program Unidrive SD with SM-Applications and SM-Applications Lite Option.

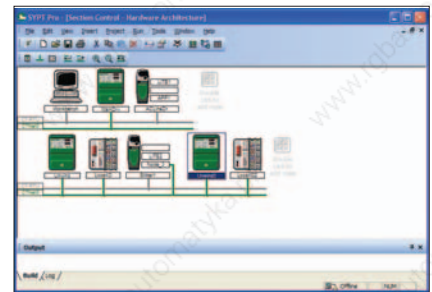

Industrial Network – SyPTPro allows you to configure a single drive or a complete drive system connected to a network. CTNet is an industrial network designed to be deterministic, robust and tolerant to noise and interference. An OPC server is available free of charge from your local Control Techniques Drive Centre or Distributor.

Programming – SyPTPro allows you to program in your choice of three programming languages; these are Function block diagram, Ladder diagram and DPL (Drive Programming Language). They offer a multi-tasking environment where the tasks are scheduled according to the required speed of execution or triggered by events.

Function Block – SyPTPro incorporates an IEC61131-3 function block diagram editor, and comes with a library of more than 250 function blocks for both simple and complex functions. These embed years of application experience to make your software easier to write and easy to re-use. Additionally you can create a library of your own function blocks or update your library via our online user resources – SyPTPro.com. All function blocks may be used in any of the three languages.

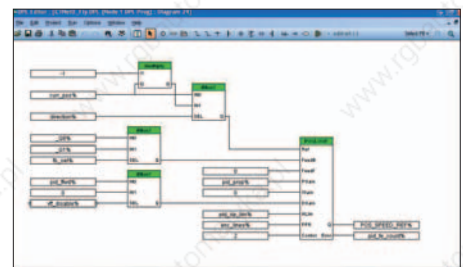

Ladder – SyPTPro incorporates an IEC 61131-3 Ladder language editor. This form of programming will be familiar to all PLC programmers and is the ideal format for sequencing and I/O control.

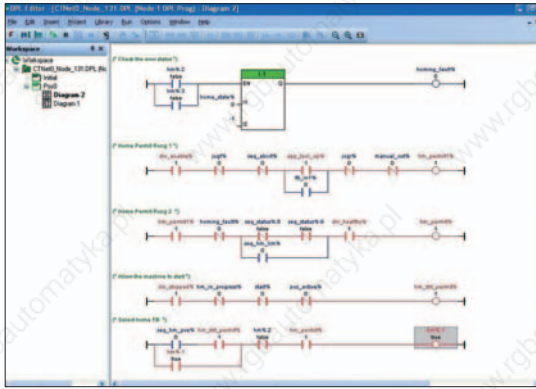

DPL – Drive Programming Language is a structured text language, as easy to use as BASIC, incorporating many standard constructs, such as IF, THEN, ELSE, and FOR, NEXT loops. DPL is ideal for initialising, configuration and general programming.

Diagnostics and debugging – Good diagnostics are essential and ensure:

- Software development time is minimised
- Commissioning time is reduced
- Down time is cut dramatically

SyPTPro contains a suite of diagnostic tools that help you to find problems with the system or software quickly and easily. When connected on-line, SyPTPro shows you live real-time views of variables in Function Block Diagrams, Ladder Diagrams and DPL, and allows you to execute program stepping and breakpoints.

System Watch Window – Allows you to monitor real-time variables and parameters from a single drive or multiple drives.

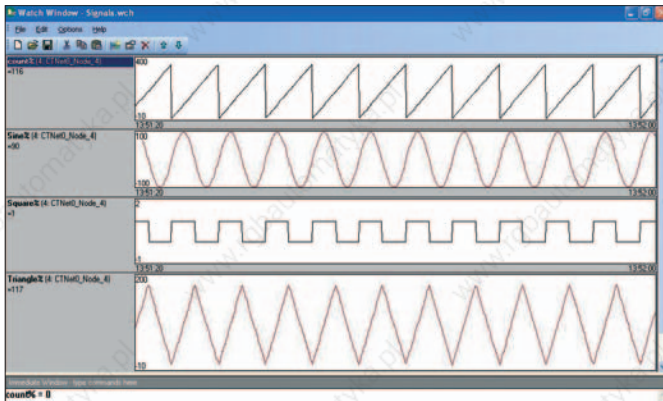

SOLUTIONS SOFTWARE

OVERVIEW

Control Techniques has produced pre-configured application programs or “Solutions,” that address standard application needs across several industries.

In addition, the Control Techniques Drive and Application Centres are staffed with professionals who can assist you in the development of high-performance custom applications. Typical applications written by our industrial control specialists include:

- Traverse Winding
- Speed Base Winders
- Rotary Knife
- Sectional Web Control
- Hoist Control
- Cut-to-Length Feeder

Application support from Control Techniques can be easily co-ordinated with delivery and installation of your hardware to ensure that the line or application is productive in the shortest amount of time possible. This program is an ideal method for fast-track learning. Engineers and machine operators can learn the features and capabilities of the programming environment, so they can support the application once it is up and running.

solutions

Dual Mode Winder

The Dual Mode Winder Application Software is the result of over 30 years of programming successful winder applications for a wide variety of materials and industries.

The term "Dual Mode" refers to the ability of the software to switch between torque and speed control modes, often a critical requirement in demanding applications such as high speed dual-turret, flying splice machines. The Dual Mode Winder Application Software supports over 95% of industrial winding applications.

The addition of a co-processor option module loaded with the Dual Mode Winder software provides a low cost flexible solution for a wide variety of winding applications.

Paper and Film Unwind and Rewinders

- Single or multi spindle
- Low tension high speed unwinds

Metal Coilers and Uncoilers

- Speed based control for thin strip with precise tension control
- Torque based control for heavy strip without tension feedback
- Speed/Torque control switching on the fly

Wire, Cable and Textile Spoolers

- Torque or speed controlled spoolers

Solutions Software	Order Code
Dual Mode Winder	SSP-4000-0010

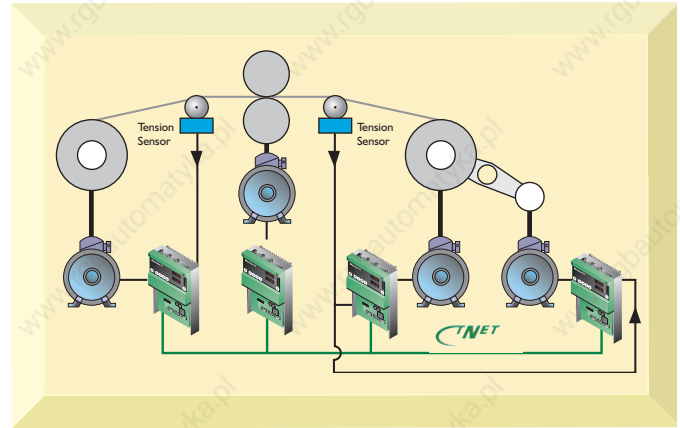

Standard Features

- Torque Control Mode, including Constant Tension Centre Wind
- Speed Control Mode
- Dancer Feedback
- Load Cell Feedback
- Dancer Air Loading Output
- Line Speed Input
- Diameter Calculator
- Inertia Compensation
- Taper Tension - linear or hyperbolic
- Unwind/Rewind Selection
- Web Break detection
- Stall Tension adjustment
- Multiple Preset Diameters
- Jog
- Torque Memory
- All data entry done using Engineering Units

Accessories

- Fieldbus communication options: Modbus, DeviceNet, PROFIBUS DP, INTERBUS and CTNet
- Expanded I/O option
- CTNet Modular I/O
- Range of HMIs
- Dynamic Braking
- Regenerative Braking

MENTOR DRIVES IN 12/24-PULSE CONFIGURATION

Thyristor DC drives for very large outputs can be obtained by using Mentor modules in a 12-pulse configuration. This results in a drive which can have up to twice the power rating of a single module. Other advantages are that large 5th and 7th harmonic currents drawn by individual 6-pulse drives are absent from a 12-pulse configuration and motor current is a lot smoother. In all 12-pulse systems a transformer with two secondary windings is necessary in order to develop two thyristor stack supplies which are equal in voltage but mutually separated by 30 degrees in phase. This is normally achieved by connecting one secondary in star and the other in delta. The primary will normally have a delta connection and will be wound for connection to high voltage distribution system.

Parallel 12-Pulse Configuration

A parallel 12-pulse drive, as its name implies, consists of two stacks with outputs connected in parallel feeding a single armature. Since the stacks will have different instantaneous output voltages it is necessary to insert an inter bridge reactor (IBR) between the stacks in order to ensure current sharing. The motor armature is fed from a centre tap of this reactor. Parallel 12-pulse drives can develop nominally the same output voltage as a 6-pulse drive. The maximum armature voltage possible is 550V for the standard voltage module and 760V for high voltage modules. The transformer secondary voltages feeding the stacks must be at least 0.83 times the armature voltage at maximum load conditions. Currents upto 3700A continuous and 5550A peak may be obtained with parallel 12-pulse drives. A typical example of a parallel 12-pulse drive for a 1000 kW motor is shown by below. The stack modules are both furnished with a completely standard control electronics assembly and configured in a master/slave load sharing arrangement. It is necessary for the currents to be balanced well enough to avoid saturation of the IBR which is normally designed to tolerate no more than 5% imbalance. Good balance is essential for cancellation of the 5th and 7th harmonics.

Parallel 12 Pulse

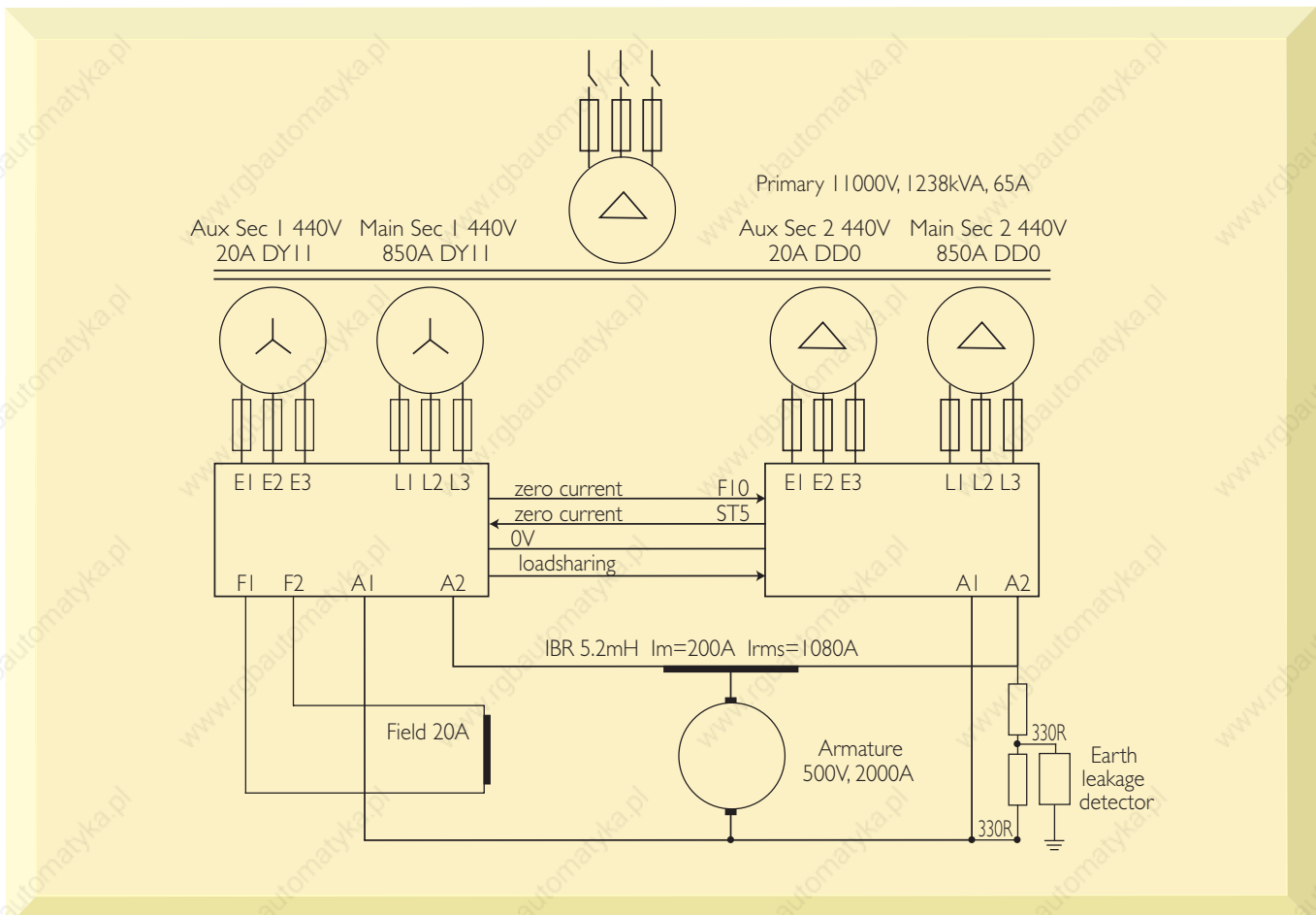

Series 12-Pulse Configuration

This configuration consists essentially of two 6-pulse modules connected in series. The armature current flows through both stacks and the total armature voltage is the series total of the two. No inter bridge reactors are necessary in this arrangement.

The maximum armature voltage possible is 1100V using the 220V/480V stack. Use of the 660V stack enable higher voltages to be obtained but are not expected to be required. Output currents up to 1850A mean (2775A peak) may be obtained using standard Mentor modules.

The implementation of a similar 1000 kW drive system as a series 12-pulse arrangement is shown below. Control of the thyristor stacks requires only one set of control electronics for both stacks. The main control card, MDA1, must be ordered with the additional connector fitted to provide delayed firing pulses for the slave stack. Bridge interlocking is provided by the same zero current detection as on a 6-pulse stack. Series 12 pulse mode is phase sensitive. The phase rotation must be in the sequence L1, L2, L3 (parameter 10.11 = 1).

Series 12 Pulse System

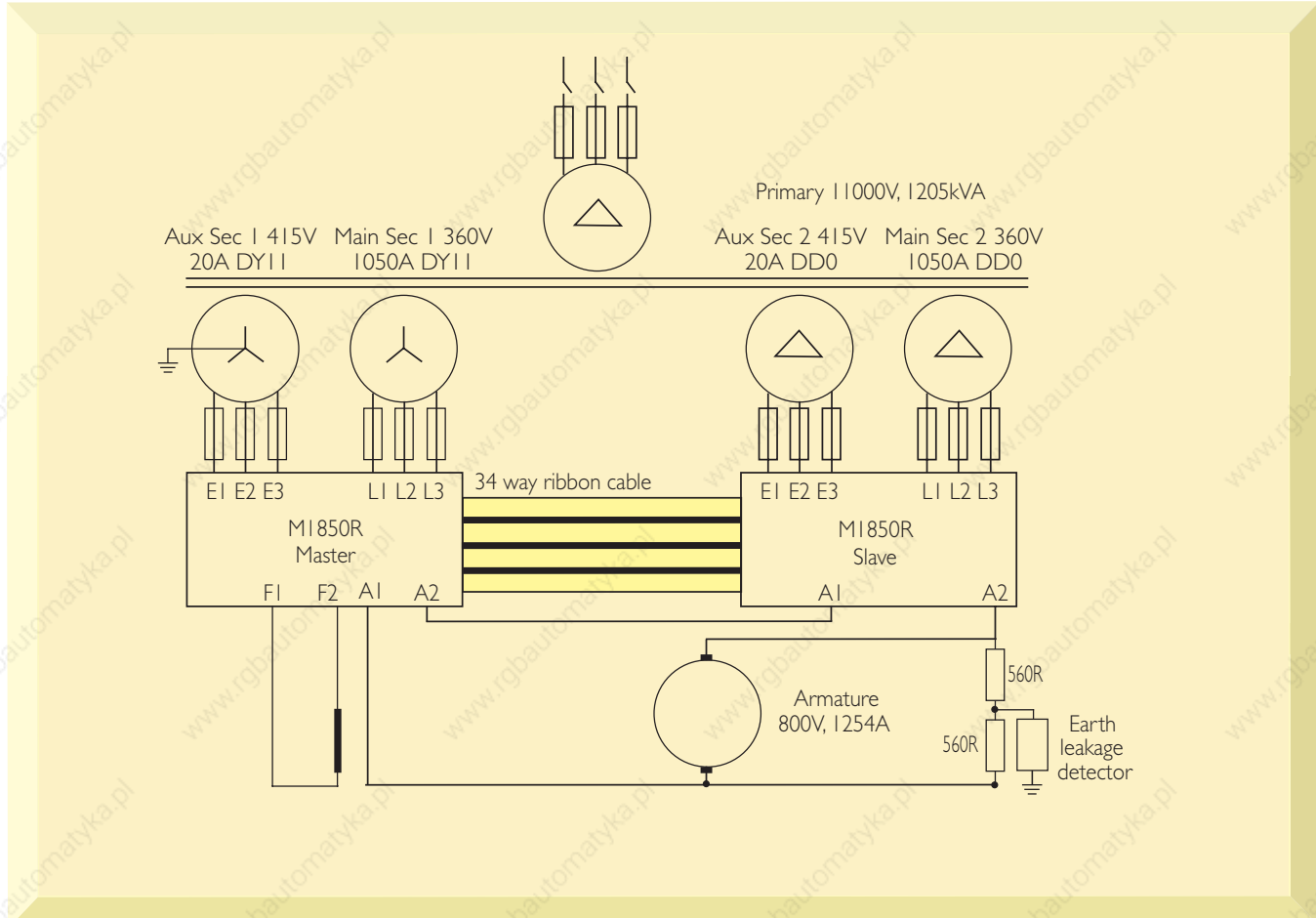

Tandem Drive Configuration

The equivalent of 12-pulse operation can be obtained by mechanically coupling two separate DC motors of equal rating and supplying the armatures from two separate stacks. The star/delta transformer must still be used. The two drive modules function as independent units in master/slave load sharing mode.

The advantage of this configuration is that no inter bridge reactor is necessary. Apart from the cost saving this results in less inductance in the armature loop thus permitting faster rates of change of current to occur which may allow a faster dynamic response to be obtained.

A typical implementation of a 1000 kW drive using two 500 kW motors is shown below. Both modules are completely standard and independent units.

The tandem drive concept can be extended to any number of motors and drives. For example, a 18-pulse system can be derived with 3 motors and a 24-pulse system may be derived with 4 motors. Harmonic cancellation is dependent on correctly phased transformer secondary windings.

As with the parallel 12-pulse system, the phase sequence and transformer winding disposition is of no consequence with a tandem drive.

Example of a Tandem Drive System

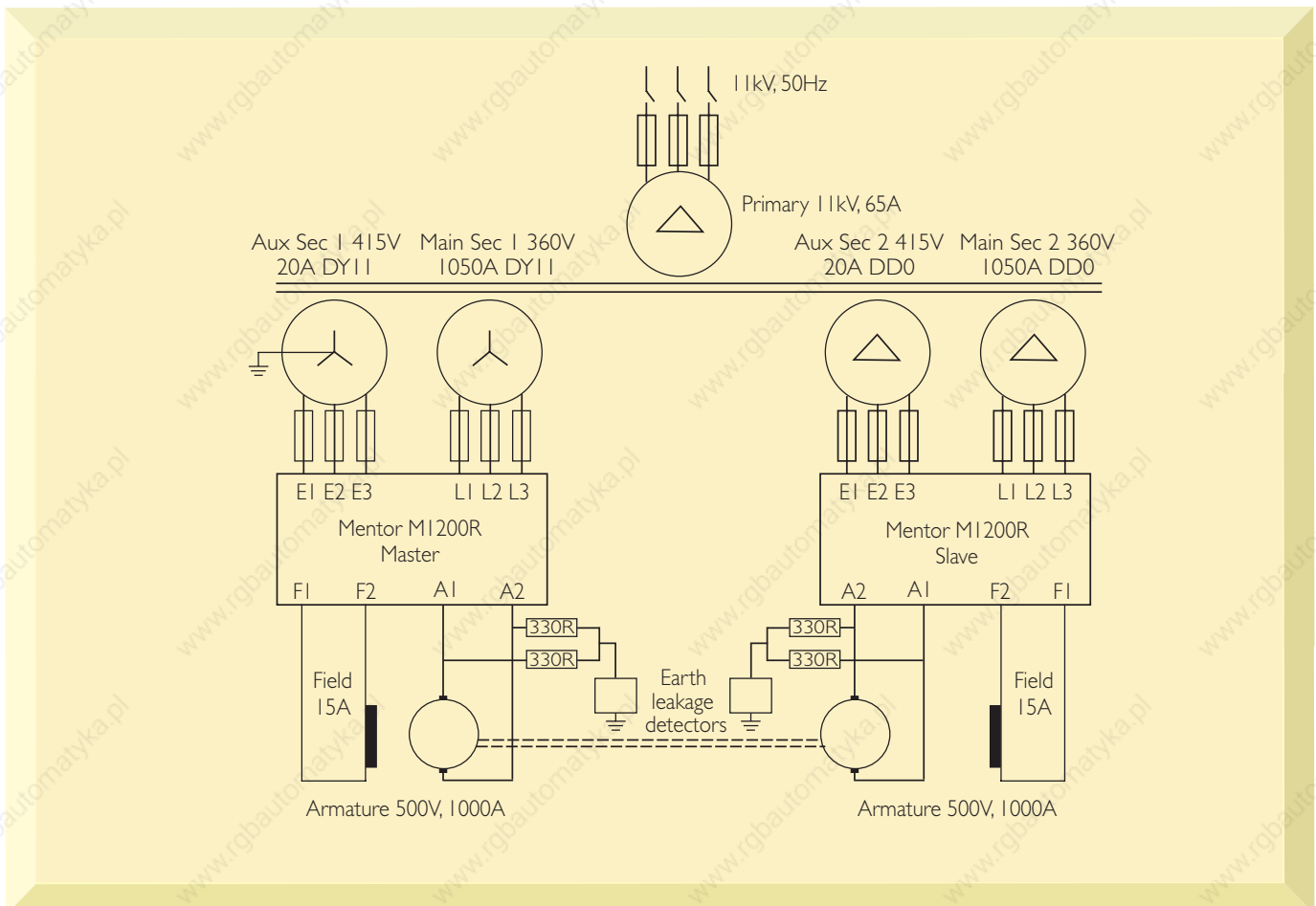

Typical Harmonic Current Levels

The table below clearly shows that the 5th and 7th harmonics are practically eliminated by using the 12 pulse arrangement.

Order of Harmonic	6-Pulse System Percentage of fundamental	12-Pulse System Percentage of fundamental
5	27	0.3
7	6.5	0.75
11	8.9	12.2
13	4.5	2.6
17	5.3	<1
19	3.3	<1
23	3.7	4.5
25	2.6	2.2
29	2.9	<1
31	2.2	<1
35	2.3	3.1
37	1.8	2
41	1.9	<1
43	1.6	<1
47	1.6	2.2
49	1.5	1.6

24 Pulse System

It is possible to extend the 12 pulse function to provide a 24 pulse system by supplying two parallel 12 pulse systems from a transformer with four phase shifted windings as shown below.

The earthing arrangement explained for the 12 pulse system should be used.

24 Pulse System Power Circuit Wiring

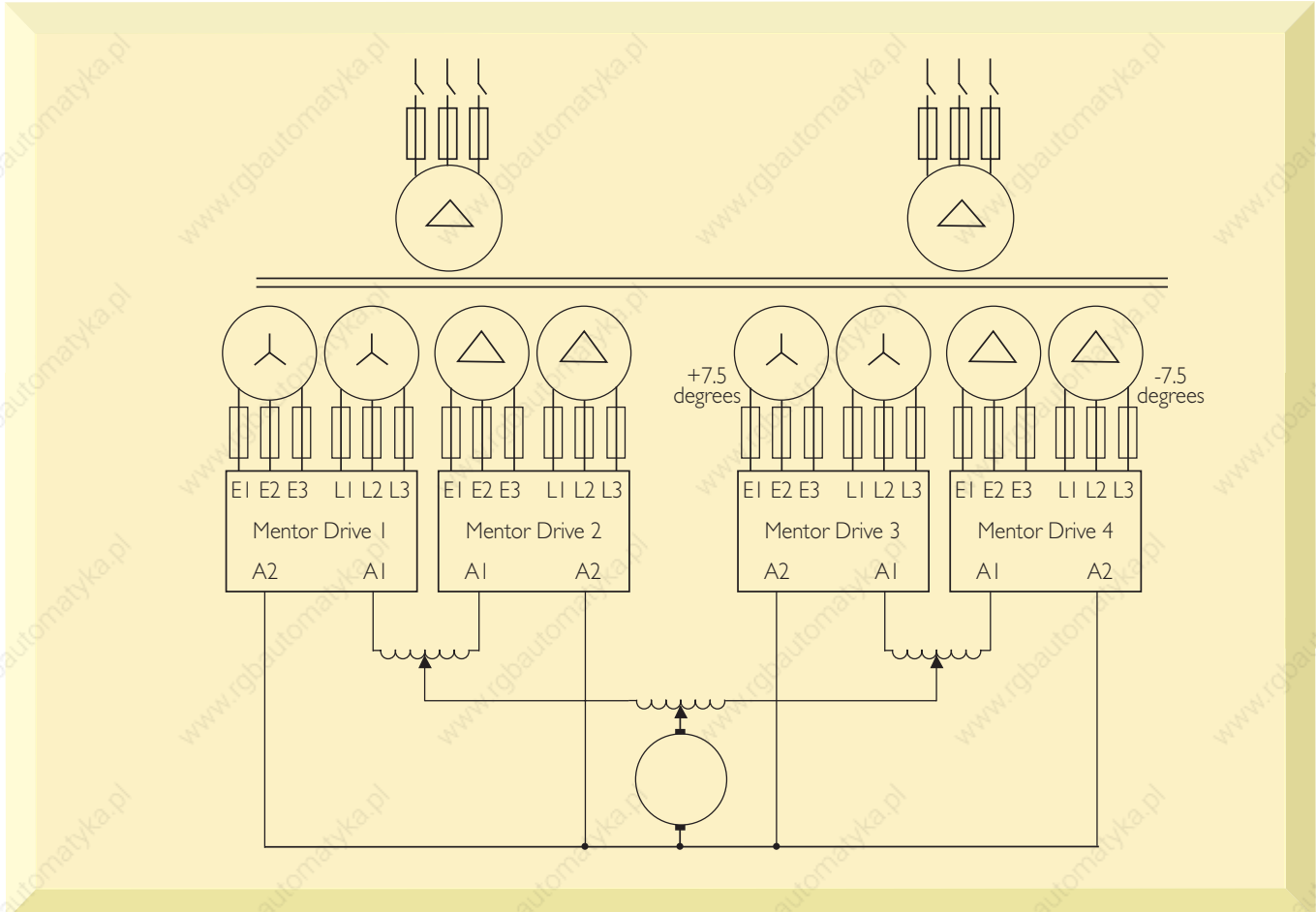

If the drives are 4 quadrant then some extra logic is needed to control the bridge interlocking.

Please consult your local Drive Centre before designing these systems.

Small DC Drives

PUMA SM, CHEETAH SM, LYNX SM & 4Q2

These low cost DC motor speed controllers are designed for the efficient, cost effective, speed control of conventional shunt wound and permanent magnet dc motors from 0.18 to 7.5kW.

KEY FEATURES

- Surface mount technology throughout the range
- All models dual input rated (see table)
- Operates in speed and torque control modes
- Armature/tacho feedback scaling
- Current feedback scaling
- Separately adjustable speed ramp
- Accepts 0-10V and 4-20mA rugged enclosure
- Cheetah SM is available in an optional IP40 rugged enclosure
- The 4Q2 model provides full quadrant control of speed and torque

RATINGS

Order Code	Input Voltage +/- 10% (V)	Typical Motor (kW)	Typical Motor (A)
Puma SM	110	0.18	3
	220/240	0.37	3
Cheetah SM	110	0.75	11
	220/240	1.5	11
Lynx SM 8	220/240	1.1	8
	400	2.2	8
Lynx SM 16	220/240	2	16
	400	4	16
Lynx SM 30	220/240	3.75	30
	400	7.5	12
4Q2/12	220/240	1.5	12
	400	2.75	12
4Q2/30	220/240	4.5	30
	400	7.5	30

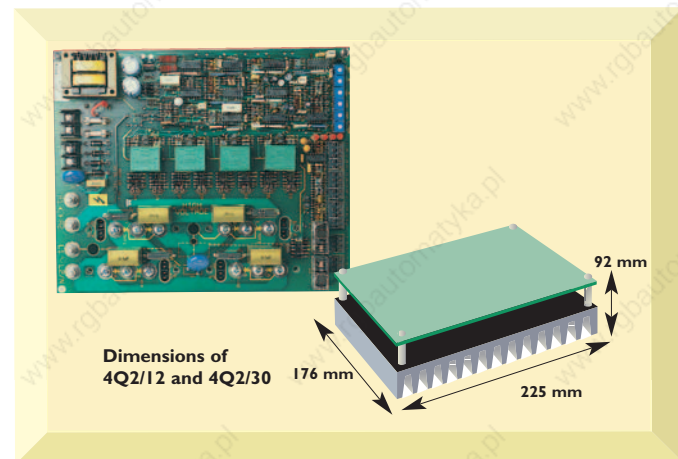
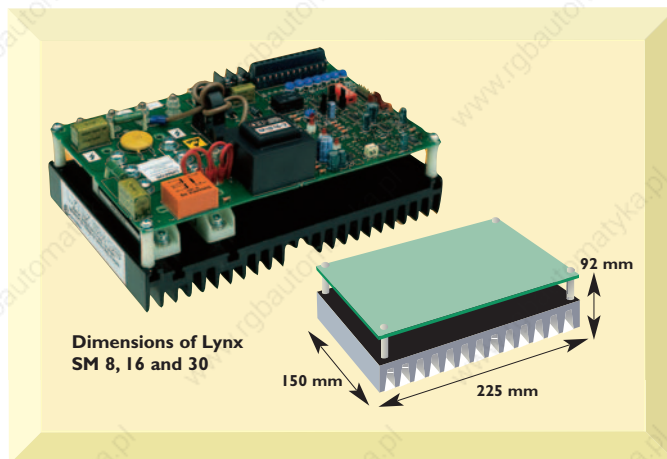
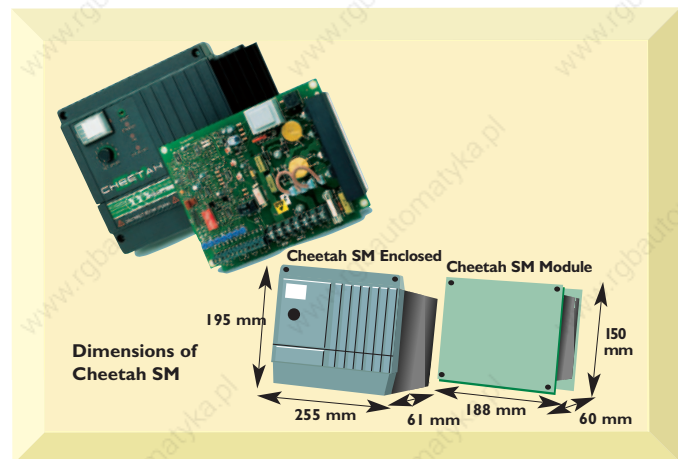
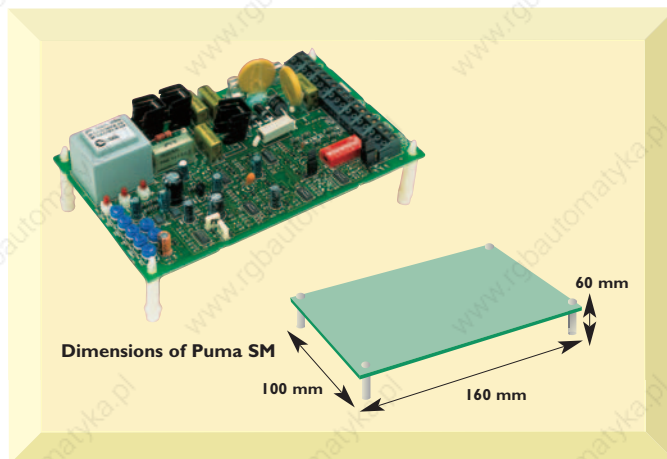

Maestro

OVERVIEW

The Maestro range of dc brushed servo drives are manufactured to the latest surface mount specifications ensuring quality, reliability and above all a cost effective solution to low power dc servo applications. Performance matched to a range of permanent magnet dc servo motors – Matador. The Maestro delivers powerful, accurate motor control in diverse applications such as robotics, transfer lines, positioning, indexing.

The 20kHz switching frequency ensures silent operation and the Maestro/Matador combination is characterised by the accuracy of its speed and control loops. The Maestro range comes in three physical sizes, Mini, Midi and Maxi.

FEATURE PERFORMANCE

- Input voltages from 24V to 150V
- Performance matched to range of Matador DC brushed servo motors
- High switching frequency for near silent operation
- Switch selectable tacho or armature feedback
- Independently adjustable accel/decel ramps
- Features plug-in customisation module for fine tuning and accurate set-up
- Mini Maestro comes in standard eurocard size and requires a dc supply
- Both the larger units have integral braking resistors
- Speed reference via $\pm 10V$ signal

Adjustments

- Speed, current limit, dynamic gain, derivative action, speed offset compensation and ramps



SPECIFICATION

Mini Maestro

Power

Power Supply From battery 24 to 72V
From rectifier with ripple 2Vpp min 20V max 80V

Max voltage at motor Rectified supply voltage minus 3V

PWM working frequency 20kHz

Min motor inductance 1mH
without choke

General

Analog speed reference $\pm 10V$ (33kOhm input impedance)

Analog current reference $\pm 10V$ (22Ohm input impedance)

Error amplifier temperature drift $\pm 25\mu V/^\circ C$

Min tacho signal at max speed 5V

Ambient working temp -10 to +45 $^\circ C$

Adjustments Full scale speed, Ramp gradient, Current limit, Dynamic gain, Derivative action, Zero offset

Diagnostics Red LED indicator when I_t is active, Green LED when indicator is drive healthy, Control output for drive status, Analog output for motor current monitoring, Analog output for requested current monitoring

Options

Link Selectable Speed control with armature feedback
Speed control with tachogenerator feedback

Protection Under-voltage 20VDC, Over-voltage 80VDC,
Over temperature 100 $^\circ C$, Output short circuit

Mini Maestro – Options

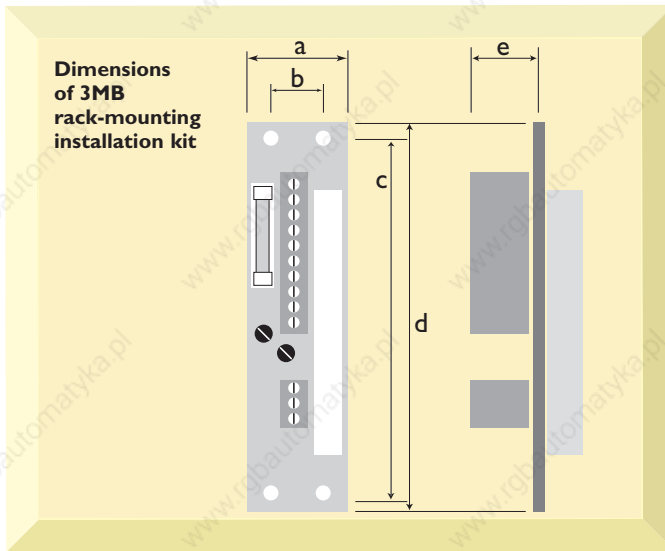

	Dimensions of 2MH panel-mounting installation kit	Dimensions of 3MB rack-mounting installation kit
Dimension	mm	mm
a	66	39.5
b	15	25.4
c	8	122.5
d	132	130
e	120	20
f	195	

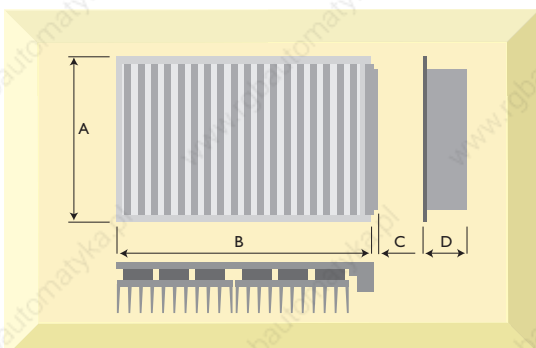
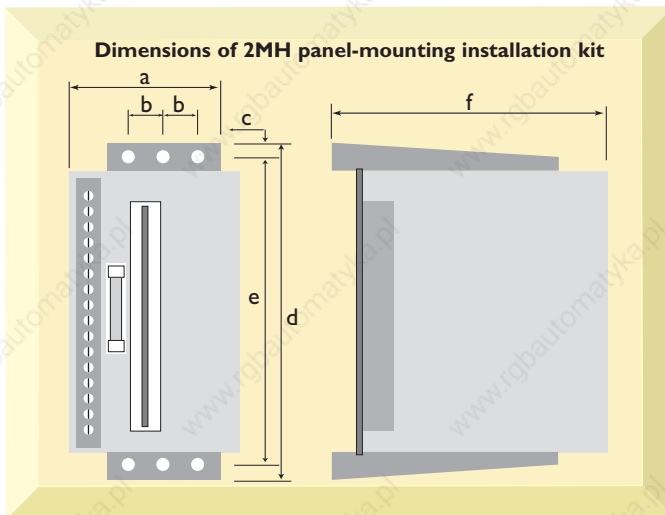

Mini Maestro motherboard dimensions	
Dimension	mm
A	100
B	160
C	8
D	41

SPECIFICATION

Midi and Maxi Maestro

Power

Power supply	From mains distribution through a 11ve transformer with a 3 phase 105Vrms output (150Vrms Output for Maxi Maestro)
Max voltage at motor	Rectified supply voltage minus 8V
PWM working frequency	20kHz
Internal braking unit	Resistance 10 Ohm, 200 Watts (External 8 Ohm, 600 Watts for Maxi Maestro)
Min motor inductance without choke	2mH (3mH for Maxi Maestro)

General

Analog reference input	$\pm 10V$ (10kOhm input impedance)
Error amplifier temperature drift	$\pm 1.3\mu V/^{\circ}C$
Min tach signal at max speed	5V
Ambient working temp	-10 to +45 $^{\circ}C$
Adjustments	Full scale speed, Ramp gradient, Current limit, Dynamic gain, Derivative action, Ref speed offset compensation
Diagnostics	Red LED indicator when I_t is active, Green LED when indicator is drive healthy, Control output for drive status, Analog output for motor current monitoring, Analog output for requested current monitoring
Options	Switch selectable Speed control with armature feedback Speed control with tachogenerator feedback Accel/decel ramp enable Tacho loss protection enable
Protection	Under-voltage 80VDC (100VDC for Maxi Maestro), Over-voltage 180VDC (275VDC for Maxi Maestro), Over-temperature 95 $^{\circ}C$, Output short circuit, Tachogenerator breakdown

Midi Maestro dimensions (mm)

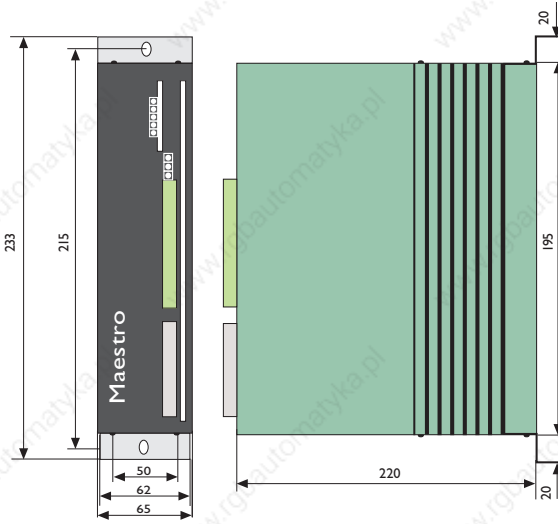

Maxi Maestro dimensions (mm)

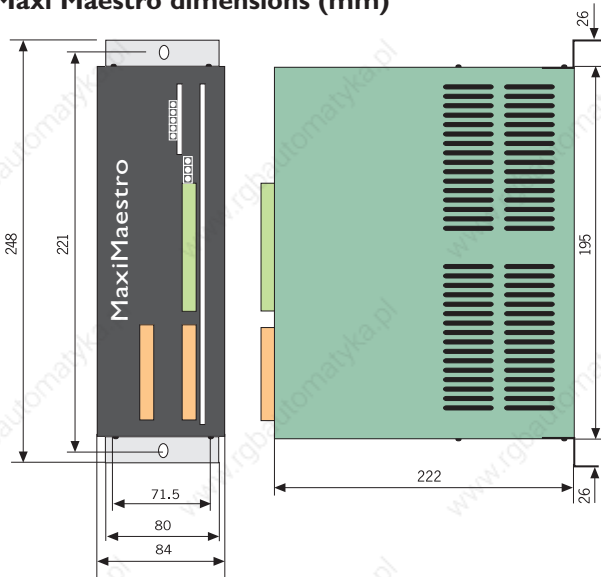

RATINGS

Frame Size	Order Code	Nominal Output (A)	Peak Current 2 s (A)	Input Voltage
Mini Maestro	DCD60*3/6	3	6	24-72VDC
	DCD60*7/14	7	14	24-72VDC
	DCD60*10/20	10	20	24-72VDC
	DCD60*14/28	14	28	24-72VDC
Midi Maestro	DCD140*8/16	8	16	105VAC
	DCD140*14/28	14	28	105VAC
Maxi Maestro	DCD200*25/50	25	50	150VAC



Matador

DC Servo Motors 3 to 25 A



OVERVIEW

The Matador range of motors was specifically designed to operate alongside the Maestro drives.

Matador DC servomotors are compact with good dynamic performance and excellent smooth low speed performance. The high commutation power allows the Matador to meet acceleration requirements without limiting the current at upper torque and speed values.

Optimum performance from a servo system is achieved by careful matching of motor and drive.

Peak currents are adjustable from 50% to 100% providing excellent flexibility in varying applications.

Motor Choke (optional)

Frame size	Model	Choke	Choke Rating	Order Code
MiniMaestro	DCD60x3/6 DCD60x7/14	L11	0.7mH, 8A	4371-1108
	DCD60x10/20 DCD60x14/28	L12	1mH, 14A	4371-1214
MidiMaestro	DCD140*8/16	L13	2mH	4371-1314
	DCD140*14/28	L13	2mH	4371-1314
Maxi Maestro	DCD200*25/50	L14	3mH	4371-1403

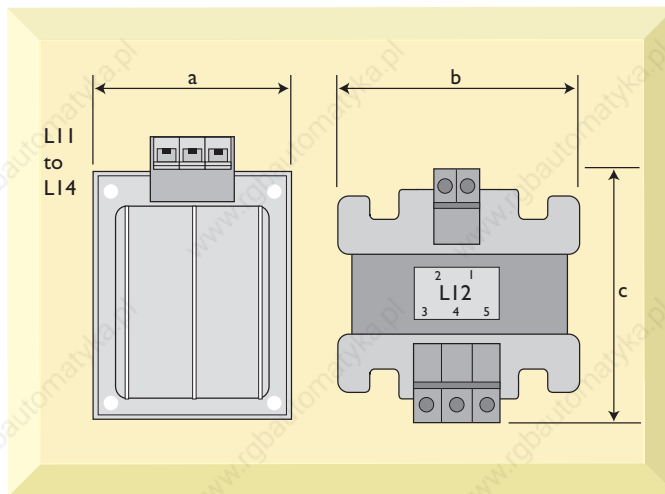

Dimension	L11 mm	L12 mm	L13 mm	L14 mm
a	56	75	102	127
b	56	75	83	105
c	64	100	105	132

FEATURES

- High dynamic performance
- Smooth low speed running
- Tachometers fitted as standard

- Long life brushes

- Low inertia

Options Include:

- Failsafe brake
- Encoder
- Special flanges
- Motor Chokes

Brake Specification

Type: Fail safe (for parking or emergency stop)

Supply voltage 24 Vdc

Motor	Holding Torque (Nm)	Motor Length Increase (mm)
DCM 2	0.5	44
DCM 3	3	44
DCM 6	12	44
DCM 9	16	44

Tachogenerator specification

	Unit	DCM
voltage constant	V/rpm	0.01
peak to peak ripple	%	1.6
rms ripple	%	0.7
linearity error	%	0.1
voltage tolerance	%	± 5.0
voltage variation	% per °C	-0.02
nr. of comm. segments		25
nr. of poles		4

Type Definition

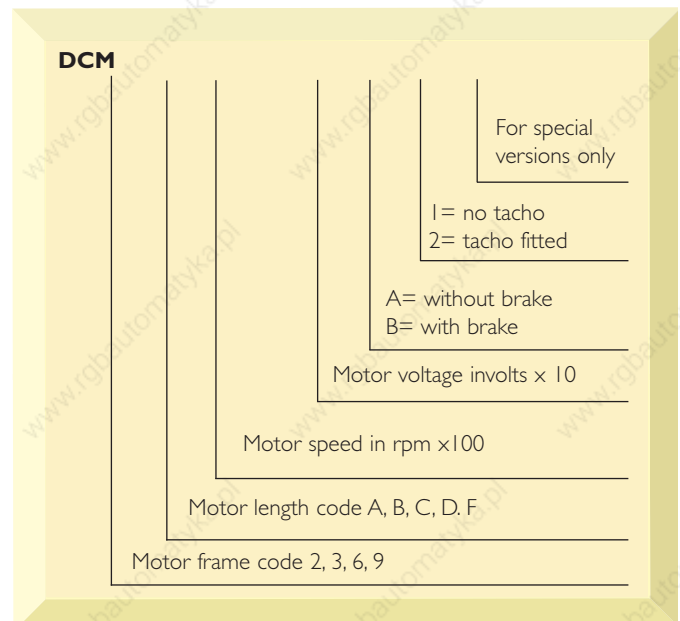

DIMENSIONS (mm)

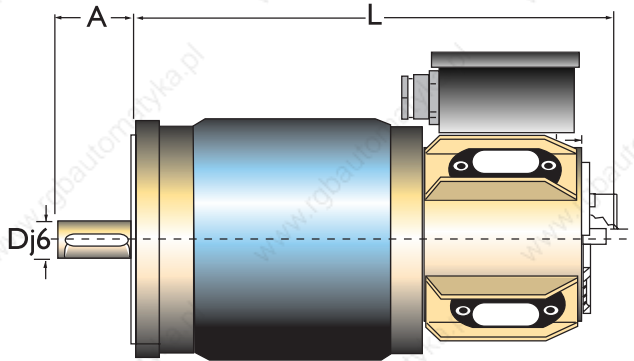
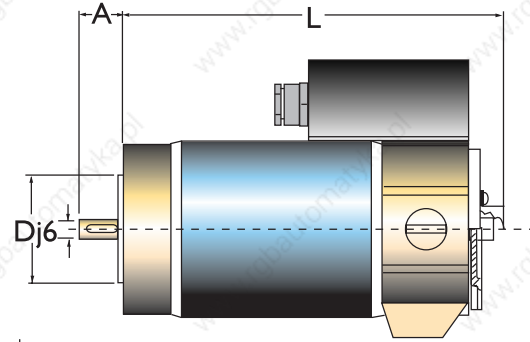
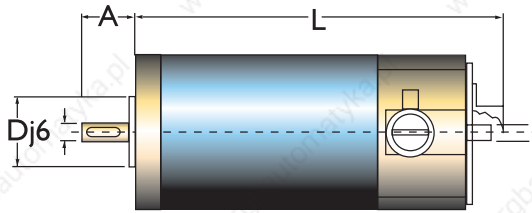

TYPE	2B	2C	3B	3D	3F	6C	6D	6F	9B	9C
A	20	25	23	30	30	40	40	40	50	50
L	136.5	184	212	267	322	338	338	410	350	472
D(j6)	7	9	11	14	14	19	19	19	24	24
L with brake and tacho	222.5	270	297	352	407	424	424	496	438	560
L with brake	180.5	228	256	311	366	382	382	454	394	516
L with tacho	178.5	226	253	308	363	380	380	452	394	516

MAESTRO AND MATADOR SELECTION TABLE

Maestro Drive	Matador Motors Preferred Types	Rated Stall Torque (Nm)	Rated Stall Current (A)	Max. Peak Current (A)	Rotor Inductive (mH)	Volt Constant (V/lkrpm)	Rotor Inertia 10 ⁻³ Kg m ²	Choke Reference
DCD 60* 7/14	DCM 2B 30/03	0.32	4.6	23	1.34	7.3	0.0324	N/A
DCD 60* 7/14	DCM 2C 30/03	0.47	4.6	23	1.65	10.7	0.0607	N/A
DCD 60* 7/14	DCM 3B 35/06	0.93	7	35	1.11	13.8	0.6	N/A
DCD 60* 10/20	DCM 3D 30/06	1.6	10	50	1.1	16.5	0.8	N/A
DCD 60* 14/28	DCM 3F 30/06	2	12.5	62.5	3.04	16.5	1	LI2
DCD 140* 8/16	DCM 6C 30/14	3.5	9	45	3.4	40	1.8	N/A
DCD 140* 14/28	DCM 6D 30/14	5.5	14	70	1.65	40	2.8	LI3
DCD 200* 25/50	DCM 6F 30/14	7.5	21	105	0.85	37.5	5.1	LI3
DCD 200* 25/50	DCM 9B 30/20	11	20	90	2.3	57	10	N/A
DCD 200* 25/20	DCM 9C 30/20	15	27.5	124	1.39	57	14	LI4

Consult Drive Centre/Distributor for complete range of Matador motors

SPEED TORQUE CURVES

DCM 2B 30/03
Mini Maestro DCD 60* 7/14

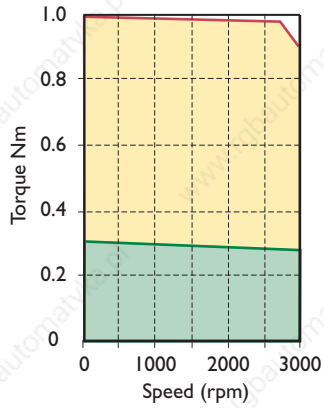

DCM 2C 30/03
Mini Maestro DCD 60* 7/14

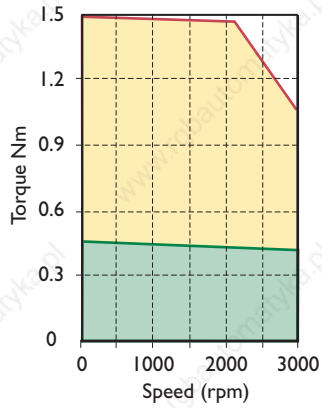

DCM 3B 35/06
Mini Maestro DCD 60* 7/14

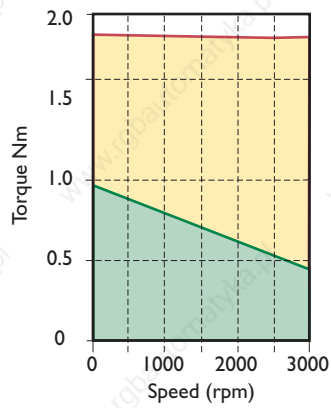

DCM 3D 30/06
Mini Maestro DCD 60* 10/20

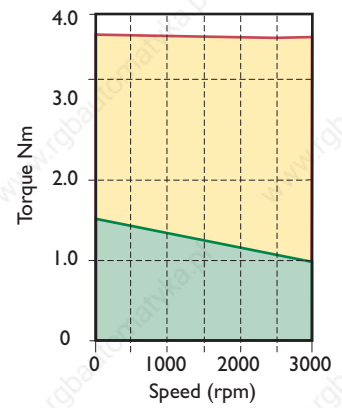

DCM 3F 30/06
Mini Maestro DCD 60* 12/28

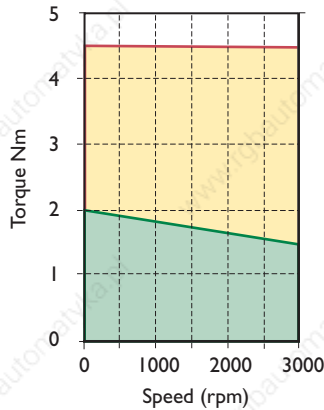

DCM 6C 30/14
Maestro DCD 140* 8/16

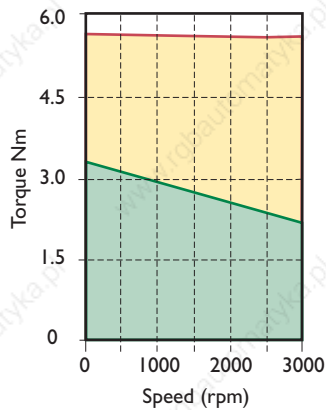

DCM 6D 30/14
Maestro DCD 140* 14/28

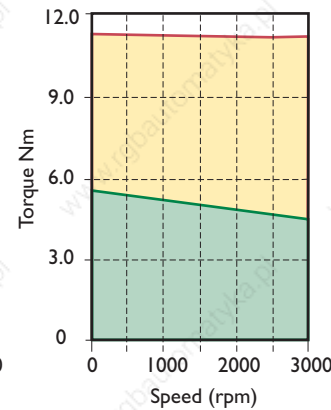

DCM 6F 30/14
Maxi Maestro DCD 200* 25/50

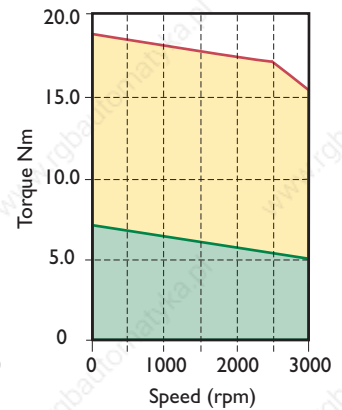

DCM 9B 30/20
Maxi Maestro 200* 25/50

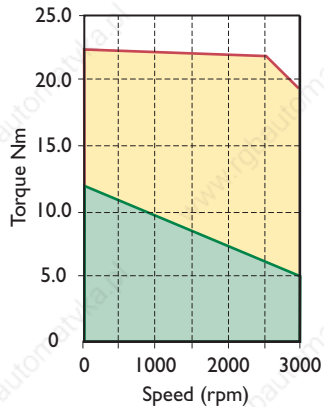

DCM 9C 30/20
Maxi Maestro 200* 25/50

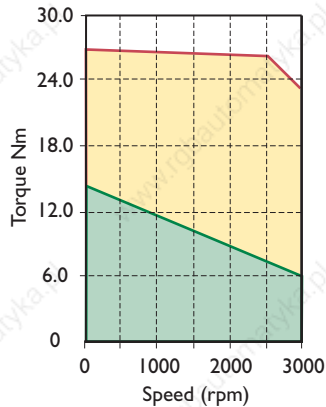

Unidrive **SD** - the Servo Solutions Platform

OVERVIEW

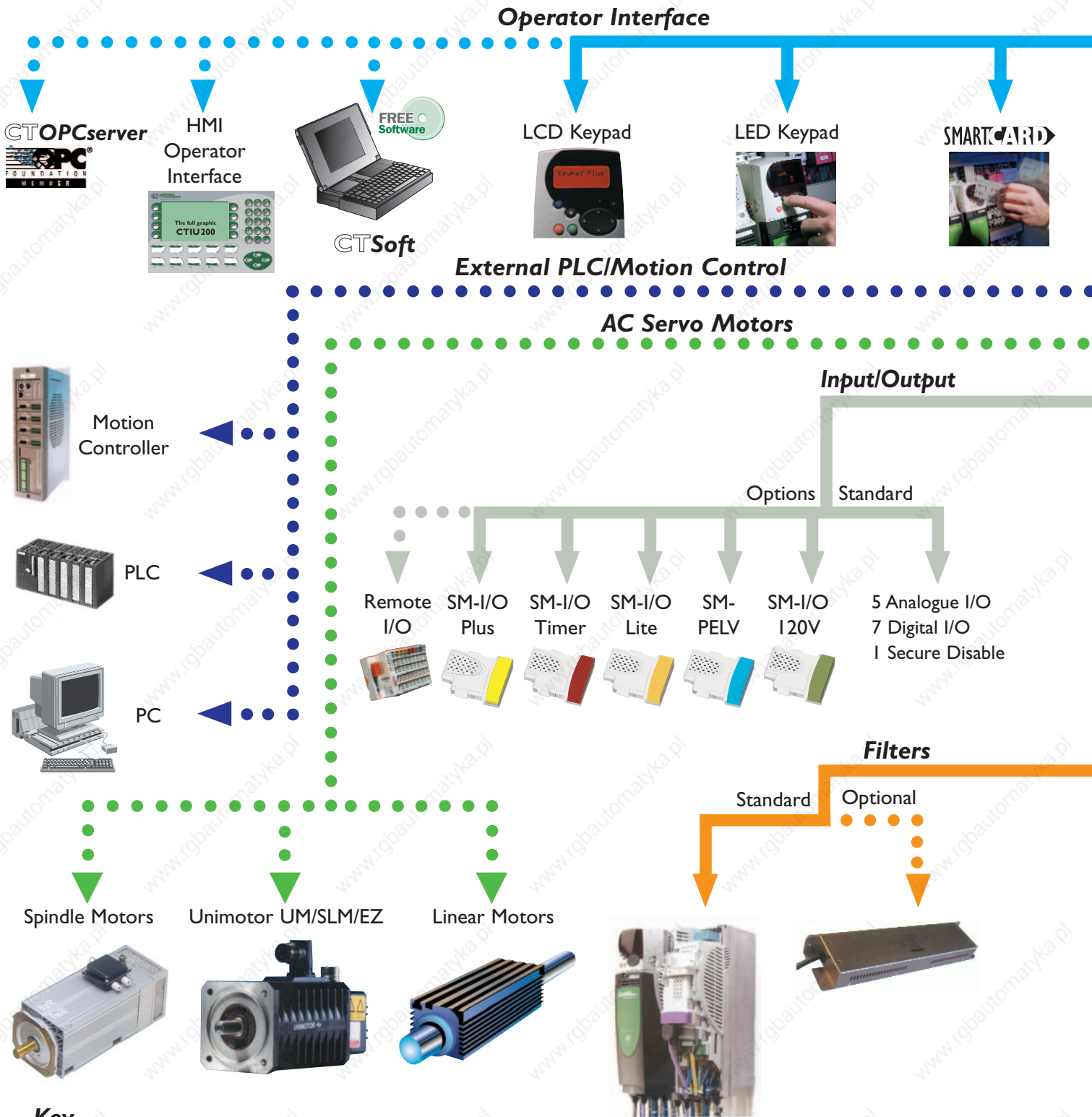

Key

- = External to Unidrive **SD**
- = Internal to Unidrive **SD**

Unidrive **SD** Servo Overview



Applications with PLC or Motion functionality

SM-Applications Lite OR SM-Applications OR SM-EZMotion



Programming Platform
 SyPTLite OR SyPTPro (IEC61131-3)

Programming Platform - Power ToolsPro
 Motion Made Easy
 Indexing
 Gearing
 Profiles

Feedback

PLC Functionality Features
 Function Block Programming
 Ladder Logic Sequencing

AND

Motion Functionality Features
 Embedded Position Loop
 Function Block Programming
 Ladder Logic Sequencing



Standard

SinCos
 Quadrature
 Frequency/Direction
 Clockwise/
 Counter clockwise



Communications

Options

SM-Universal Encoder Plus



Accepts or replicates all standard feedback types

SM-Encoder Plus



Quadrature

SM-Resolver



Standard

Options



Modbus RTU



PROFINET



CAN Interface



DeviceNet



Ethernet



CANopen



TNET



SERCOS interface



SLM technology

Unidrive **SD** Servo

OVERVIEW

The Unidrive **SD** is "The Benchmark" for AC servo controls in the automation industry. It is a truly scalable "Solutions Platform" with the flexibility to be personalised to customers' requirements, and lower total cost while maximising productivity.

The Unidrive **SD** "Solutions Platform" incorporates many cost saving and performance improvement features based on input from End Users and OEMs. This includes Secure Disable, Fieldbus capability, on-board EMC filter, Universal feedback device support, and the facility for up to three Solution Modules to tailor the drive to specific application needs. The dynamic servo performance makes the Unidrive **SD** the ideal "Solutions Platform."

Unidrive **SD** Servo Overview

- **Universal Digital AC Drive**
- **4.3 to 80A, 3 phase, 200-240 VAC**
- **2.1 to 210A, 3 phase, 380-480 VAC**
- **4.1 to 125A, 3 phase, 575 VAC**
- **19 to 125A, 3 phase 690VAC**
- **Secure Disable for contactor elimination to EN954-1 cat 3**
- **SMARTCARD** – Parameter and application program cloning and back up card
- **Universal feedback interface with 12 selectable modes**
- **High Resolution Analog Input (16 bit plus sign)**
- **RS485 Interface for PC connection**
- **Three zero-space universal option slots**

*Note: Additional components are necessary to produce a regen drive package.

SERVO SOLUTIONS PLATFORM



Typical Servo Applications

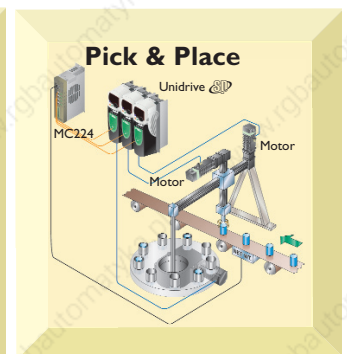
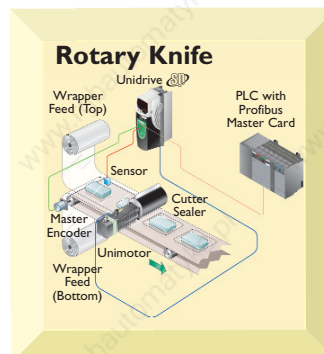
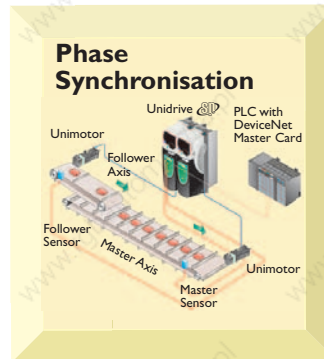
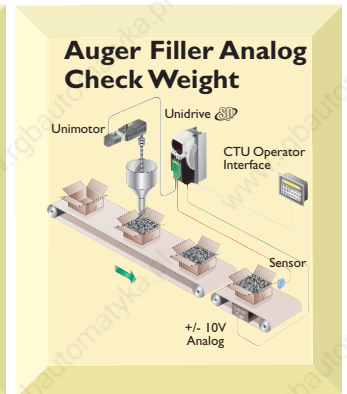

FEATURE PERFORMANCE

Secure Disable

The Unidrive Secure Disable function meets the requirements of EN954-1: category 3 for machine safety, and can serve as a part of a category 4 application. Control Techniques' Secure Disable safety solution has been independently verified by the German safety organization, BIA. This exclusive feature of the Unidrive saves money and space. Under many conditions, this standard feature eliminates the need for safety contactors by utilising secure circuitry to prevent the motor shaft from being driven by the drive.



Order Code: 0175-0317

Multiple Fieldbus Capability

The Unidrive provides unrivaled fieldbus flexibility. In addition to the standard Modbus RTU port, up to three fieldbus option modules can be installed in the Unidrive 's option slots. This provides the capability to control and monitor a Unidrive on multiple fieldbus networks. For example, a single Unidrive can be configured to communicate on both DeviceNet and PROFIBUS networks simultaneously, and even provide a gateway between networks. In the example shown, CTNet is used to provide real-time co-ordination between two Unidrive modules. The DeviceNet and PROFIBUS connections allow data to be passed to the controllers in a machine line.

Motion/PLC Functionality with Unidrive

In addition to the extensive drive configuration capabilities of the Unidrive , scalable programming is available to solve virtually any application requirements. Simple logic function programming is achieved using software and the drive's built in PLC. More complex systems can be solved by adding SM-Applications Lite (with or) and SM-Applications (only) option modules.



SM-Applications



SM-Applications Lite

Secure Disable

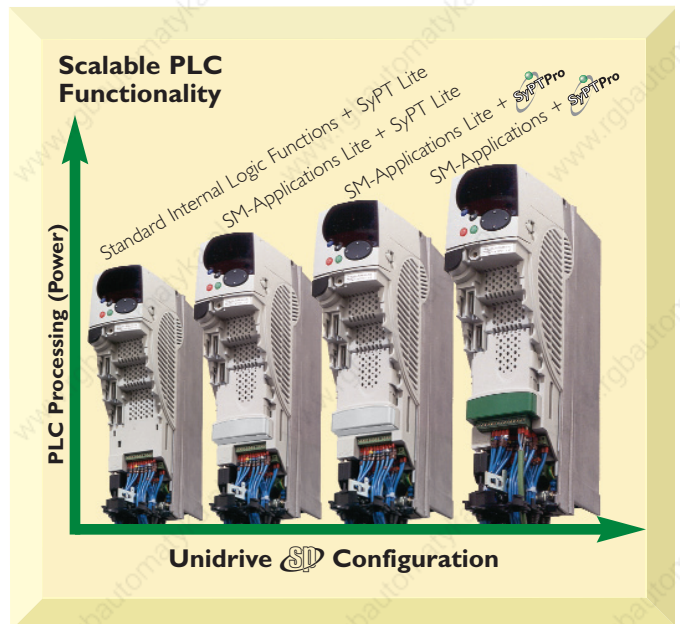
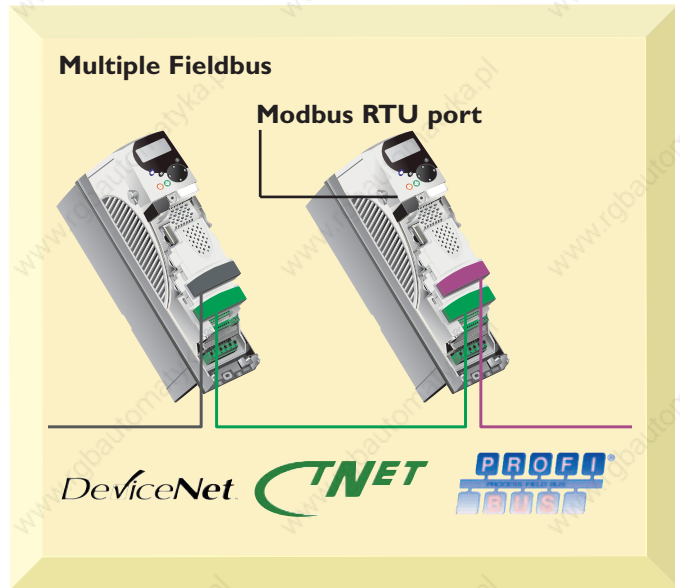
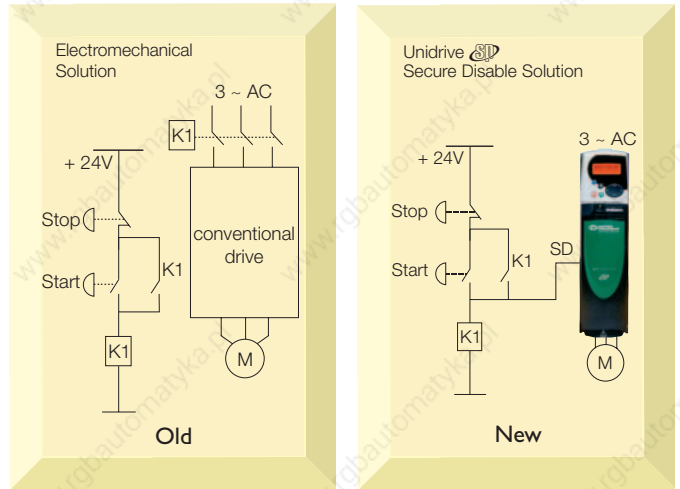

Unidrive Servo

FEATURE PERFORMANCE

Low Voltage DC operation

Ideally suited for elevator rescue and machine tool set up.

24V DC Auxiliary Power Supply Input

Provides an additional means of maintaining control, fieldbus and position loop on mains loss.

Comprehensive Autotune

Inertia measurement and static autotune reduce startup time.

Universal Feedback Interface

Supports 12 different feedback configurations, including several absolute encoders. No need for additional components.

High Resolution Analog Input

16-bit, 250 µsec (sample time) interface for high performance applications.

Extensive Fieldbus Connectivity

ModbusRTU (Standard), PROFIBUS-DP (12Mbit), DeviceNet, CANopen, INTERBUS, Ethernet, SERCOS and CTNet via zero-space SM Application modules.

Up to three fieldbuses can connect to a single drive, eliminating the need for expensive gateways.

Three Universal Option Slots

Fieldbus, control and application SM modules fit in any of the three option slots beneath the drive cover.

Secure Disable Function

Conforms to EN954-1 Category 3 for machine safety with system cost reduction.

SMARTCARD for Simple Setup, Cloning and Back-up

Easy-to-use card stores drive configuration for simple startup and parameter cloning. Supplied free with Unidrive .

Keypad Options

Choose no keypad, high visibility LED keypad or multi-language LCD keypad based on the system design and operating environment.

Drive Mounted Brake Resistor

Unidrive  sizes 1 and 2 feature a drive mounted brake resistor option to reduce panel space requirements.

Standard Features of the Unidrive

- 32-bit application co-processor module (up to a maximum of 3 modules)
- Universal Encoder feedback
- Application functions for Torque control, Brake control, and Axis-limit control
- Built-in shaft orientation mode
- Digital lock with adjustable ratio (frequency slaving)
- Programmable boolean logic (AND, NAND, OR, NOR) gates with delay outputs
- Programmable threshold comparators
- Built-in PID controller
- S-ramp accel / decel profiling
- Built-in Motorized potentiometer (MOP)
- 8 Preset speeds and independent accel / decel rates
- Run time chronometers
- Configurable analog and digital I/O
- Selectable stopping modes including Coast, Ramp, and DC injection
- Dynamic braking capability
- Removable control terminals common to all sizes
- Intelligent Thermal Management (ITM) technology with switching frequencies up to 16 kHz
- Regeneration option – see Unidrive  section 3.1 for details

RATINGS

Unidrive SD Servo		Continuous Output Current	Peak Output Current
200 / 240 VAC +/- 10% 3 Phase			
Order Code	Frame	I _H (A)	I _{PK} (A)
SP1201	1	4.3	7.5
SP1202		5.8	10.2
SP1203		7.5	13.1
SP1204		10.6	18.6
SP2201	2	12.6	22.1
SP2202		17	29.8
SP2203		25	43.8
SP3201	3	31	54.3
SP3202		42	73.5
SP4201	4	56	98
SP4202		68	119
SP4203		80	140

380 / 480 VAC +/- 10% 3 Phase			
Order Code	Frame	I _H (A)	I _{PK} (A)
SP1401	1	2.1	3.7
SP1402		3	5.3
SP1403		4.2	7.4
SP1404		5.8	10.2
SP1405		7.6	13.3
SP1406		9.5	16.6
SP2401	2	13	22.8
SP2402		16.5	28.9
SP2403		25	40.2
SP2404		29	45.5
SP3401	3	32.0	56.0
SP3402		40.0	70.0
SP3403		46.0	80.5
SP4401	4	60	105
SP4402		74	130
SP4403		96	168
SP5401	5	124	217
SP5402		156	273
SP6401	6	180	270
SP6402		210	315

RATINGS Cont.

575 VAC +/- 10% 3 Phase			
Order Code	Frame	I _H (A)	I _{PK} (A)
SP3501	3	4.1	7.2
SP3502		5.4	9.5
SP3503		6.1	10.7
SP3504		9.5	16.6
SP3505		12	21.0
SP3506		18	31.5
SP3507		22	38.5
SP4603 ①	4	27	47
SP4604 ①		36	63
SP4605 ①		43	75
SP4606 ①		52	91
SP5601 ①	5	62	109
SP5602 ①		84	147
SP6601 ①	6	100	150
SP6602 ①		125	188

690 VAC +/- 10% 3 Phase			
Order Code	Frame	I _H (A)	I _{PK} (A)
SP4601	4	19	32
SP4602		22	39
SP4603		27	47
SP4604		36	63
SP4605		43	75
SP4606		52	91
SP5601	5	63	109
SP5602		85	147
SP6601	6	100	150
SP6602		125	188

Suitable for demanding applications, current overload is set at 175% for 40 seconds. Where motor rated current is less than the drive rated continuous current, higher overloads (200% or greater) are achieved.

① The same model can be used on a 575V or a 690V supply, and has two different output ratings. For example: At Normal Duty, SP4603 is suitable for a 22kW output motor on a 575V supply, and a 30kW output motor on a 690V supply.

For larger servo current ratings see Heavy Duty ratings in Unidrive **SD** section 3.1.

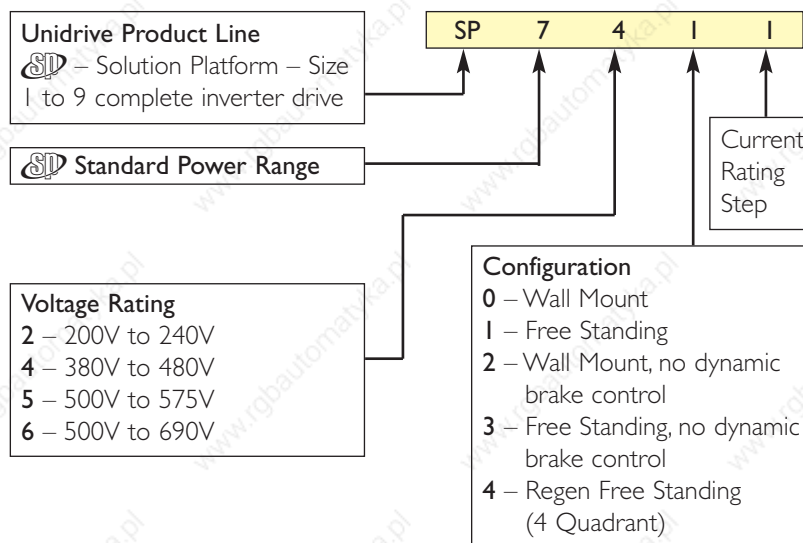

TERMINAL DIAGRAM

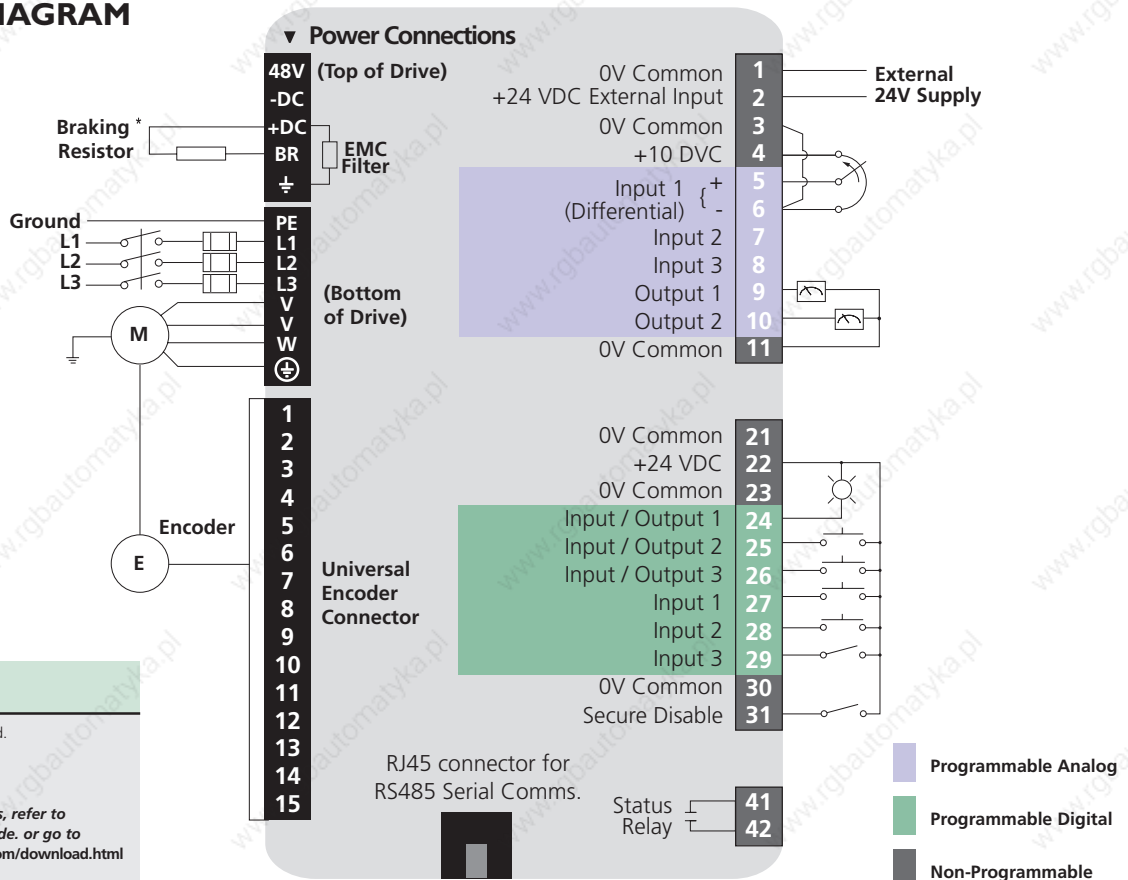

TERMINAL DESCRIPTION

Pin#	Function ①	Type/Description	Notes
1	0V Common		
2	+24 VDC External Input	Back up Power Supply for Control	60W, 24VDC
3	0V Common	Common for External Analog Devices	
4	+10VDC	Reference Supply	10 mA max
5	Analog Input 1 (Local Frequency / Speed Reference), 16 bit	Differential Analog Input, Non-inverting Input	±10VDC 100k Ohms
6	Analog Input 1 (Local Frequency / Speed Reference), 16 bit	Differential Analog Input, Inverting Input	±10VDC 100k Ohms
7	Analog Input 2 (Remote Frequency / Speed Reference), 10 bit	Single-ended Analog Input	±10VDC, 100k Ohms or 4-20 mA _i , 200 Ohms
8	Analog Input 3 (Motor Thermistor), 10 bit (Trip at 3.3kOhm)	Single-ended Analog Input	±10VDC, 100k Ohms or 4-20 mA _i , 200 Ohms
9	Analog Output 1 (Frequency / Speed Monitor)	Single-ended Analog Output, Bi-polar	±10VDC or 0-20 / 4-20mA
10	Analog Output 2 (Motor Torque Monitor)	Single-ended Analog Output, Bi-polar	±10VDC 0-20 / 4-20mA
11	0V Common	Common for External Analog Signals	

Pin#	Function ①	Type/Description	Notes
21	0V Common		
22	+24 VDC	User Supply	200 mA max
23	0V Common	Common for External Digital Inputs	
24	Digital I/O 1 (Zero Speed Output)	Digital Input / Output	0 to 24VDC input, or 1 to 24VDC, 100 mA max output
25	Digital I/O 2 (Reset Input)	Digital Input / Output	0 to 24VDC input, or 1 to 24VDC, 100 mA max output
26	Digital I/O 3 (Run Forward Input)	Digital Input / Output	0 to 24VDC input, or 1 to 24VDC, 100 mA max output
27	Digital Input (Run Reverse)	Digital Input	0 to 24 VDC, 7.5k Ohms
28	Digital Input (Local / Remote)	Digital Input	0 to 24 VDC, 7.5k Ohms
29	Digital Input (Jog)	Digital Input	0 to 24 VDC, 7.5k Ohms
30	0V Common	Common for External Digital Inputs	
31	Digital Input (Secure Disable)	Digital Input	0 to 24 VDC, 1µsec sample
41	Status Relay (Drive Healthy)	Normally Open	240 VAC, 2A resistive
42	Status Relay (Drive Healthy)	Normally Open	240 VAC, 2A resistive

Programmable Analog Programmable Digital All Analog I/O is scalable

① Values in (parenthesis) designate default functions.

② 0-20, 20-0, and 20-4 mA are also available. See Unidrive SP Manual.

SPECIFICATION

Environment

Ambient Operating Temperature	0° to 40°C 0° to 50°C with derating
Cooling method	Forced convection
Humidity	95% maximum non-condensing at 40°C
Storage Temperature	-40° to 50°C
Altitude	0 to 3000m. Derate 1% per 100m between 1000m and 3000m.
Vibration	Tested in accordance with IEC 68-2-34
Mechanical Shock	In accordance with IEC 68-2-27
Enclosure	IP 20 (NEMA1), IP 54 (NEMA12) through panel mounting
Electromagnetic Immunity	In compliance with IEC801 and EN50082-2, and complies with EN61800-3 with built-in filter
Electromagnetic Emissions	In compliance with EN50081-2 when the recommended RFI filter is used and EMC installation guidelines are followed

AC Supply Requirements

Voltage	200 to 240 VAC ±10% 380 to 480 VAC ±10% 500 to 575 VAC ±10% 500 to 690 VAC ±10%
Phase	3Ø
Phase Imbalance Tolerance	2% negative phase sequence (equivalent to 3% voltage imbalance between phases)
Frequency	48 to 65 Hz
Input Displacement Power Factor	0.93

Control

Switching Frequency	3, 4, 6, 8, 12, 16 kHz
Output Speed	0 to 40,000 rpm (Closed loop)
Frequency Accuracy	±0.01% of full scale
Frequency Resolution	0.001 Hz
Analog Input Resolution	16 Bit + sign (Qty 1), 10 Bit + sign (Qty 2)
Serial Communications	2 or 4-wire RS232 or RS485. Protocol is ANSI x 3.28-2.5-A4, or Modbus RTU Baud rate 300 to 115,200

Braking	Dynamic braking transistor standard
Mains Dip Ride Through	Up to 1 second depending on inertia and decel time

Protection

DC Bus Undervoltage Trip	175 / 350 / 435 VDC (approximately 124 / 247 / 307 VAC line voltage)
DC Bus Overvoltage Trip	415 / 830 / 990 VDC (approximately 293 / 587 / 700 VAC line voltage)
MOV Voltage Transient Protection	160 Joules, 1400VDC clamping (Line to line and line to earth)
Drive Overload Trip	Current overload value is exceeded.
Instantaneous Overcurrent Trip	225% of drive rated current
Phase Loss Trip	DC bus ripple threshold exceeded
Overtemperature Trips	Drive heatsink, control board, and option module(s) monitoring
Short Circuit Trip	Protects against output phase to phase fault
Earth Fault Trip	Protects against output phase to ground fault
Motor Thermal Trip	Electronically protects the motor from overheating due to loading conditions

Approvals & Listings

UL, cUL	Listed E171230
IEC	Meets IEC Vibration, Mechanical Shock and Electromagnetic Immunity Standards
CE	Designed for marking
NEMA	NEMA 1 enclosure type
VDE	Meets VDE Electromagnetic Emissions Standards
ISO 9001: 2000	Certified Manufacturing Facility
ISO 14001	Certified Manufacturing Facility

DIMENSIONS (mm)

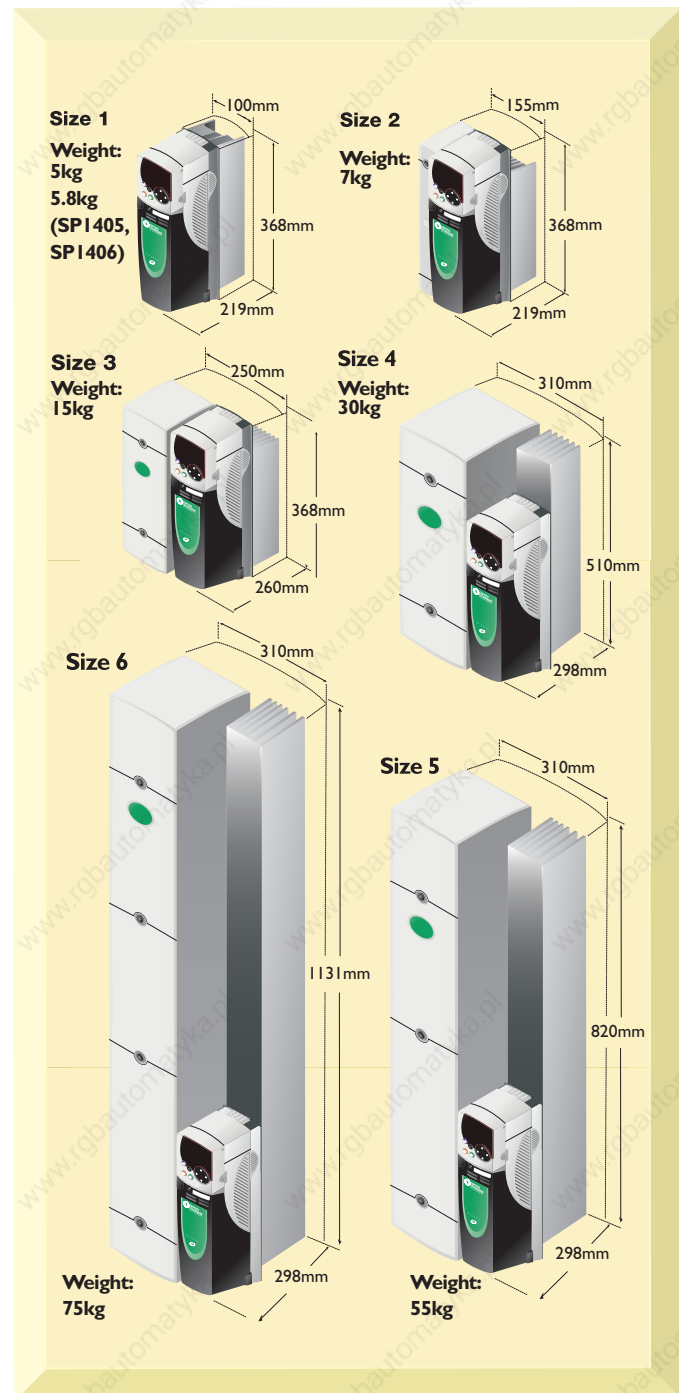

OPTIONS

The Unidrive **SD** provides application and system designers with an incredibly flexible drive platform, which is easily modified by an extensive range of sophisticated SM option modules that can be used singly or in combination for economical and space saving solutions. SM option modules install easily into any of the three option slots, with no tools required. The I/O, feedback, memory, communication and application modules enable the Unidrive **SD** to provide an optimised solution regardless of the demands of the application.

A complete range of other accessories are available to simplify system intergration and meet system design criteria.



Options At-A-Glance

Option	Description	Order Code
Drive Configuration and Programming	Cloning and Programme Storage Card	Smart Card***
	Configuration Tool Communications Cable	CTSoft*** CT Comms Cable
Operator Interface	No Keypad	As standard
	LED Keypad Backlit LCD Keypad Operator Interfaces	SM-Keypad SM-Keypad Plus See section I2.3
Power Accessories	Internal Fitting Brake Resistor Panel Mounting DB Resistors E Stop Duty Wall Mounting DB Resistors	SM - Heatsink DBR To suit application To suit application Cyclic Duty As standard To fit drive
	Internal Fitting EMC Filter External Fitting EMC Filters	
Motor Feedback	Universal Encoder Feedback	SM-Universal Encoder Plus
	Second Encoder Feedback Resolver Input Feedback Encoder Terminal Connector	SM-Encoder Plus SM-Resolver** SM-ETC
Input/Output	Extended I/O	SM-I/O Lite
	Extended I/O with Real Time Clock Extended I/O Double Insulated Extended I/O 120V I/O Remote Network I/O	SM-I/O Timer SM-I/O Plus SM-PELV SM-120V I/O Beckhoff I/O
Communication	Modbus RTU (Standard)	SM-Applications*
	PROFIBUS-DP INTERBUS DeviceNet CTNet CAN Interface CANopen Ethernet SERCOS SLM Interface	SM-PROFIBUS-DP SM-INTERBUS SM-DeviceNet SM-Applications SM-CAN SM-CANopen SM-Ethernet SM-SERCOS SM-SLM
Application	System Programming	SM-Applications
Co-processor	System Programming	SM-Applications Lite
Modules	Motion Made Easy Servo	SM-EZMotion**
Application Programming Software	SyPTLite (IEC61131-3)	Free with Unidrive SD
	SyPTPro (IEC61131-3) PowerTools Pro	SyPTPro Free download from Control Techniques.com
Solutions Software	Flying Shear Control	SSP-4000-0020

* Provides additional Modbus RTU port. *** Supplied as standard with Unidrive **SD**

** Only one of these modules per drive.

DRIVE CONFIGURATION AND PROGRAMMING

SMARTCARD

This is a **standard** feature that enables simple configuration of parameters in a variety of ways. The **SMARTCARD** can:

- 'Clone' a complete set of parameters for serial production
- Save multiple complete sets of parameters
- Set up an application as parameter differences from default
- Automatically save all user parameter changes for maintenance purposes
- Load complete motor map parameters
- Read/write **SMARTCARD** information from written SM-Applications and SM-Applications Lite



The drive only communicates with the **SMARTCARD** when commanded to read or write, meaning the card may be "hot swapped".

CTSoft

CTSoft is a complimentary Windows based drive configuration tool designed to enable the complete control and display of all parameters within a Unidrive **SD**. Functions within CTSoft allow data to be uploaded, viewed and saved, or retrieved from disk, modified and printed. It can be used off-line in the office or on-line in the factory. CTSoft communicates with the Unidrive **SD** via the computer's serial port to the drive's RS485 port using a communications cable (CT Comms cable) or via SM-Ethernet module.

Some of CTSoft's capabilities include:

- Remote Upload/Download
- Parameter Saving
- Drive and SM-Application Reset
- Monitor Screens
- Multiple Window Display
- Block Diagram Animation
- Project Storage



**CTSoft IS SUPPLIED WITH THE DRIVE
OR VISIT
www.controltechniques.com/download.htm**

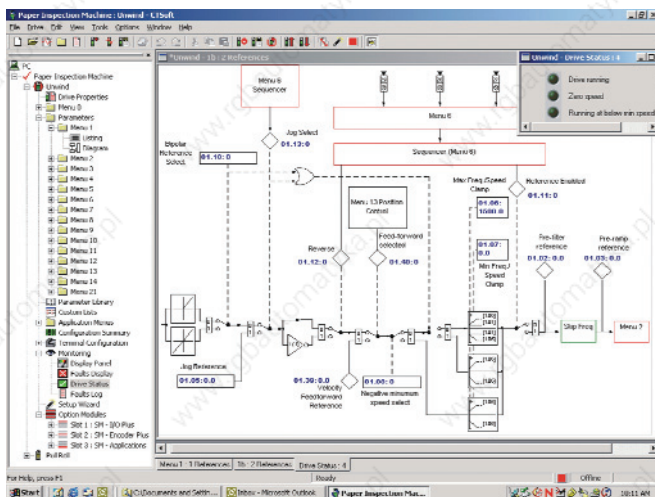

Communications Cable

Using an RS232 to RS485 converter you can connect the PC to the RJ45 serial port on the front of the drive. A pre-made cable is available from Control Techniques for this purpose – this same cable is used with other Control Techniques products that use a RJ45 RS485 connector such as the Commander SK.

The RJ45 socket is located under a small flap on the front of the Unidrive **SD** just below the keypad. The pin-outs of this connector are described in the Unidrive **SD** User Guide.



Order Code	Description
CT Comms Cable	PC-to-drive Comms Cable
USB CT Comms Cable	USB-to-drive Comms Cable

OPERATOR INTERFACE

Keypad Options

The Unidrive $\mathcal{S}\mathcal{D}$ can operate without a keypad, or with either the SM-Keypad or SM-Keypad Plus. The SM-Keypad is a full-function, 7-digit LED data display. The SM-Keypad Plus is a back-lit LCD display option that can be remote mounted, has 5 languages, plus custom text database, on-line help, and HMI features. Both keypads are "hot-pluggable," enabling them to be moved from one drive to another without powering down.



SM-Keypad



SM-Keypad Plus

HMI Operator Interface Unit

The HMI operator interface units have a back-lit LCD display and easy-to-use navigation keys.

Using the intuitive "WYSIWYG" page editor, they can be programmed to display a variety of menus, submenus, alarms, fault conditions and other critical information. The HMIs support a range of capabilities including multiple font sizes, real time trends and graphs, scheduling and background programs. They communicate via Modbus RTU and, to simplify installation, some are rated IP54 and require no screw mounting holes.

Operator Interface Range

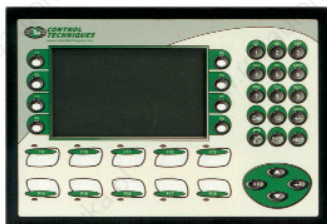

HMI 200

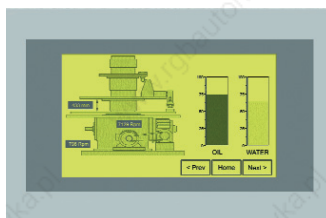

VTI55W



TIU500

POWER ACCESSORIES

Internal Dynamic Braking Resistors

Dynamic braking resistors provide a means of rapidly stopping motor and load. The mechanical energy stored in the spinning mass is converted into electrical energy and quickly dissipated into the resistor. The ohmic value and power rating of the resistor is a function of the drive type.

A dynamic braking resistor is available for heatsink mounting on size 1 and 2 drives. No external thermal protection device is required as resistors are electronically protected by drive firmware.



Size 1 Unidrive $\mathcal{S}\mathcal{D}$ heatsink shown

Unidrive $\mathcal{S}\mathcal{D}$ Size	DC Resistance	Power Rating
1	75 R	100W
2	37.5 R	200W

E-Stop Duty Dynamic Braking

Panel mounted DB resistors are designed for non-cyclic use where energy dissipation from an active drive is required. Resistors are supplied with mounting hardware unless otherwise noted.

Cyclic Duty Dynamic Braking

These heavy-duty kits have been designed to provide dynamic braking for cyclic and continuous braking applications.

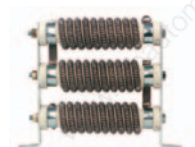

Onboard EMC Filter

An internal EMC filter is provided as standard with the Unidrive $\mathcal{S}\mathcal{D}$. It is adequate for most industrial applications. The filter conforms to EN61800-3 (second environment) when motor cable length does not exceed a certain length, dependant on model.

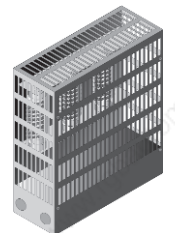

External EMC filters

EMC filters are used to minimize high frequency power supply line disturbances caused by PWM AC drives that may interfere with proper operation of sensitive electronic equipment. These specific filters have been assessed for conformance with the EMC directive by testing with the appropriate Control Techniques drives.



Mounting Style

- Bookend: filter mounts next to the drive with the smallest dimension being the width of the filter
- Footprint: filter mounts between the drive heatsink and the panel or enclosure
- Block: filter mounts on the panel near the drive



Optional External EMC Filters

Drive	Order Code	Drive	Order Code
SP1201 to SP1202	4200-6118	SP3401 to SP3403	4200-6305
SP1203 to SP1204	4200-6119	SP4401 to SP4403	4200-6406
SP2201 to SP2203	4200-6210	SP5401 to SP5402	4200-6503
SP3201 to SP3202	4200-6307	SP3501 to SP3507	4200-6309
SP4201 to SP4203	4200-6406	SP4601 to SP4606	4200-6408
SP1401 to SP1404	4200-6118	SP5601 to SP5602	4200-6504
SP1405 to SP1406	4200-6119	SP6401 to SP6402	4200-6603
SP2401 to SP2404	4200-6210	SP6601 to SP6602	4200-6604

MOTOR FEEDBACK

The Unidrive has a built-in Universal encoder port that accepts the following signal types:

- Quadrature Incremental
- Pulse and Direction
- Forward and Reverse Pulses
- Quadrature with commutation
- Forward and Reverse Pulses with commutation
- SinCos without commutation
- Absolute SinCos using **HIPERFACE®** E1485 serial protocol
- Absolute encoder
- Absolute SinCos using serial communications protocol
- Absolute **SSI** encoder
- Commutation only e.g. from Hall Effect sensors

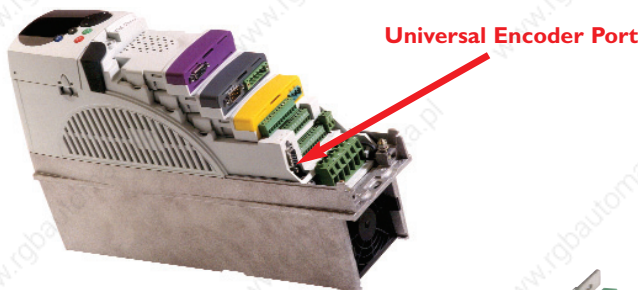

Encoder Terminal Connector

The 15 way D-type converter is used to simplify motor feedback wiring by "Breaking out" the 15-pin D-connector signals to screw terminals.



SM - ETC

SM-Universal Encoder Plus

The SM-Universal Encoder Plus module provides the Unidrive with an additional feedback port with the same functionality as the base drive, plus a simulated encoder output that can be programmed to operate in the following modes:



- SinCos with Commutation
- Quadrature Incremental
- Pulse and Direction
- SSI

The module also incorporates freeze inputs for applications requiring position capture.

SM-Encoder Plus

The SM-Encoder Plus module provides an additional incremental encoder feedback port.



More than one SM-Encoder Plus and/or SM-Universal Plus Encoder module may be installed in a single drive.

SM-Resolver

This module enables the Unidrive to control the speed and position of motors fitted with resolvers. Because of their ruggedness, resolvers are often used in hot, demanding environments.



- Input Impedance:** >85 Ohms
- Transformation Ratio:** 3:1 or 2:1
- Excitation Frequency:** 6kHz
- Excitation Voltage:** 6V or 4V rms sine wave

Maximum Motor Speed	Feedback Resolution	Simulated Encoder Output (ppr)	
		Quadrature Format	Frequency & Direction
0-3,300 rpm	14 bit	4096	8192
3,301-13,200 rpm	12 bit	1024	2048
13,201-40,000 rpm	10 bit	256	512

The encoder simulated output can be sourced either from the resolver or the main drive encoder.

INPUT/OUTPUT

SM-I/O Lite

Additional I/O (1 x Analog Input ($\pm 10V$ bi-polar or 4-20mA), 1 x Analog Output (0-10V or 4-20 mA), 3 x Digital Input and 1 x Relay).

SM-I/O Timer

As per SM-I/O Lite but with the addition of a Real Time Clock for scheduling drive running.

SM-I/O 120V

Additional I/O conforming to IEC6 1131-2 120VAC. 6 inputs and 2 non-protected relay outputs rated for 120VAC operation.

SM-I/O PELV

Double Insulated Extended I/O to NAMUR NE37 specifications for chemical industry applications.

SM-I/O Plus

This module enables the drive system designer to solve more complex applications by providing additional inputs and outputs that the Unidrive Servo can access locally. These connections are on removable terminal strips and are programmable using CTSoft or the drive's keypad.

SM I/O Plus Terminal Diagram

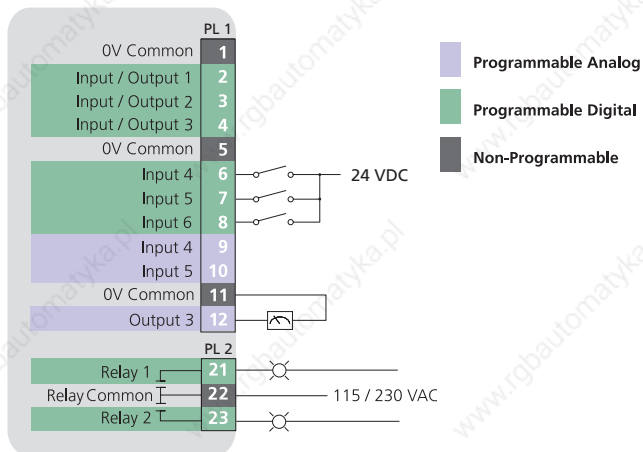

SM I/O Plus Terminal Description

Quantity	Description	Notes
2	Relay Contacts (N.O.)	110VAC, 2 A resistive
3	Digital Input	+24VDC, 7.5k Ohms
3	Digital Input / Output	+24VDC, 7.5k Ohms / +24VDC @ 10 mA max.
2	Analog Voltage Input	$\pm 10VDC$, 20k Ohms, 10 bit
1	Analog Voltage Output	$\pm 10VDC$ @ 30 mA max., 10 bit

Remote Network I/O

The high-quality Beckhoff I/O system is available for CTNet systems. Beckhoff systems for CTNet include a bus coupler and a large variety of snap-on terminal blocks allowing up to 256 digital inputs or outputs and up to 100 analog inputs and outputs per bus coupler. Up to 64 Beckhoff I/O systems can be attached to a CTNet network. I/O points can be easily read or written. Contact Control Techniques for details on the wide range of available Beckhoff Remote I/O options.

COMMUNICATION



Communications Protocol	Interface Module Order Code	System Configuration
Modbus RTU*	SM-Applications	Master/Slave
PROFIBUS-DP	SM-PROFIBUS-DP	Slave
INTERBUS	SM-INTERBUS	Slave
CTNet	SM-Applications	Peer-to-Peer
DeviceNet	SM-DeviceNet	Slave
CANopen	SM-CANopen	Slave
CAN Interface	SM-CAN	Master/Slave
SERCOS	SM-SERCOS	Slave
ModbusTCP/IP	SM-Ethernet	Slave
SMT Mail		Slave
FTP File transfer		N/A
SLM	SM-SLM	Slave

* Modbus RTU is standard. An additional Modbus RTU port can be provided with an SM-Applications module.

SM-SLM

The SM-SLM module allows connection to Control Techniques' high performance digital servo system, offering over 8,000,000 counts per revolution velocity feedback.



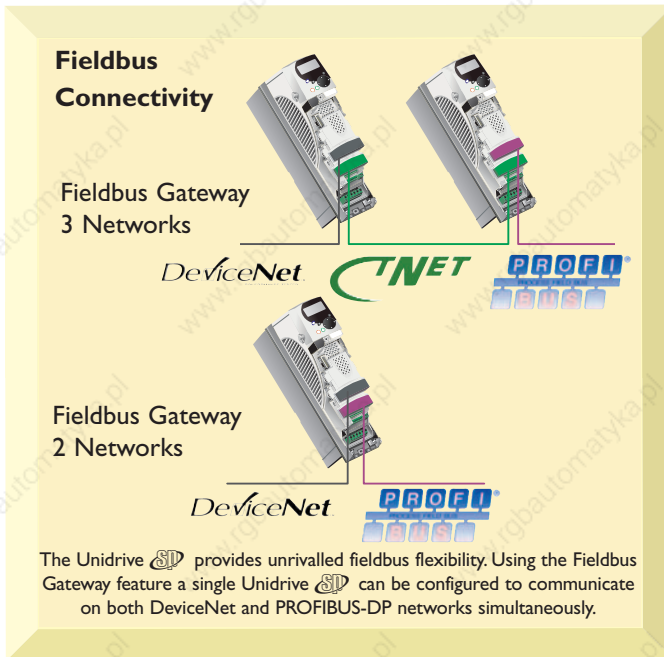



APPLICATION MODULES

SM-Applications

The SM-Applications module transforms your Unidrive  drive into a powerful automation controller that adds fast PLC functionality and can be integrated with operator interfaces, remote I/O and other intelligent devices via our drive-to-drive network CTNet. This gives you all of the benefits of a fully distributed control system including better performance, reduced cost and smaller electrical panel sizes.

Performance – The SM-Applications module contains its own high performance microprocessor, leaving the drives own processor to give you the best possible motor performance. It contains 384K of user program memory, meaning that you are never likely to be limited by the program size or processing power of the module.

Easy Powerful Configuration – The PLC functionality is programmed using  (System Programming Tool) allowing you to tackle automation problems from simple start and stop sequencing through to more complex machine and motion control applications. The device is programmed within an IEC61131-3 environment with your choice of 3 languages, meaning that you will be quickly familiar with the  intuitive user interface.  provides a suite of diagnostic and debugging features for maintenance and to help you to get your solution into service faster.

Real-Time Control – SM-Applications gives you real-time access to all of the drives parameters plus access to data from I/O or other drives. The module uses a high-speed multi-tasking



operating system with task update times as low as 250µs, fully synchronised to the drives own control kernel to give you the best possible performance for drive control and motion.

Input/Output – The module has two digital inputs and two digital outputs for high-speed I/O operations such as position capture or actuator firing and a fast optically isolated RS485 port, supporting standard protocols such as; Modbus for connection to external devices like Operator Interface panels or synchronous communication using the  protocol.

Standard Solutions – Where applicable standard software Solutions such as winder, flying shear and duty assist are available to help to simplify the development and commissioning process.

SM-Applications Lite

The SM-Applications Lite module is designed to solve your automation requirements where intelligence is needed on a stand-alone drive or a drive connected to a centralised controller via I/O or Fieldbus.

The Module provides many of the functions of SM-Applications but may be programmed using either  or . SM-Applications Lite with  gives you an intermediate level automation solution that is suitable for a wide variety of applications, while  and SM-Applications Lite will allow you to exploit the full power and performance of the option module in stand-alone applications.

SM-EZMotion

The SM-EZMotion is ideal for all of your motion control applications whether simple or highly complex. Windows™ based PowerTools Pro configuration software helps to simplify applications whilst maintaining flexibility and functionality.

The module is equipped with four digital inputs and two digital outputs for external control. Simplify all of your motion applications by using the built-in High-Speed Capture, Queuing, Profile Summation, and Program Multi-tasking capabilities. Ease of use defines this multipurpose motion controller. Take advantage of all its features to quickly solve these applications:

- Simple Indexing
- Pick and Place
- Flying Shear
- High Speed Labelling
- Phase Synchronisation
- Random Infeed Control
- Rotary Knife
- And many more...

PROGRAMMING SOFTWARE

SyPTLite

SyPTLite is a ladder diagram editor that allows you to develop programs that can be executed onboard Commander SK with LogicStick, onboard the Unidrive SD built-in PLC or on SM-Applications Lite option modules.

SyPTLite is designed to meet the needs of the majority of automation users wishing to extend the functionality of the drive to add simple PLC functionality such as drive control and sequencing. The software has been developed with a definite focus on intuitive ease of use allowing you easy access all of the drives parameters and to monitor and debug your program on line.

SyPTLite contains a comprehensive library of functions that is based on a subset of those available in the SyPTPro programming tool. These include:

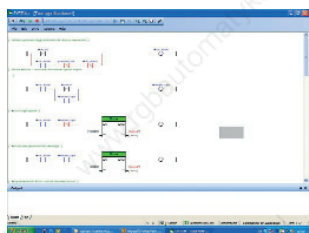

- Arithmetic Blocks
- Timers
- Multiplexers
- Bit Manipulation
- Comparison Blocks
- Counters
- Latches
- SMART(A;I;D)

SyPTLite with Unidrive SD onboard PLC

Unidrive SD supports ladder-programming capability, i.e. the drive itself is capable of storing and executing a SyPTLite program without the requirement for additional option modules. The drive is prioritised to execute all motor control related functions first and will use any remaining processing time to execute the SyPTLite ladder diagram as a background activity.

The SyPTLite program may be copied to or from the Smartcard on the drive, allowing the data to be safely stored or retrieved for serial machine manufacture and maintenance purposes.

SyPTLite with SM-Applications Lite and Unidrive SD

The SM-Applications Lite contains it's own high-performance microprocessor, of the same type as used in the drive, giving you access to a step change in PLC power and more than doubling the program size available up to 10kb. Using this option module gives you the flexibility to decide how your program task will run, either background or cyclic. The cyclic task means that the program will start on a fixed time-base that is synchronised with the drives own internal control loops. The time-base is selectable between 1 – 200ms.

SM-Applications Lite and SyPTLite offer a compelling alternative to traditional mini-PLC systems, in applications where cost, foot print size and performance are critical.

Note: Full SM-Applications does not support SyPTLite programs.



FREE Software SyPTLite IS SUPPLIED FREE WITH THE DRIVE OR VISIT www.controltechniques.com/download.htm

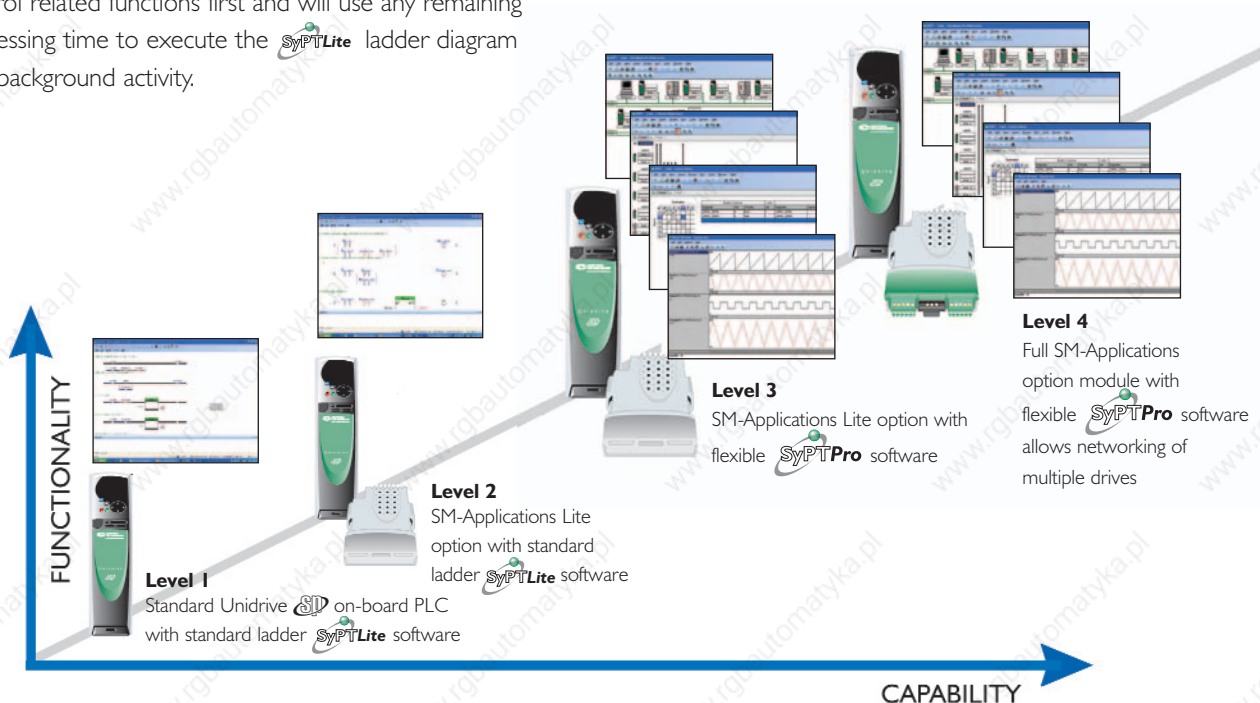

SyPTPro – System Programming Toolkit

Overview – SyPTPro is the professional drive programming toolkit for OEM's and End Users who wish to maximise the performance of their machines and factory. This IEC61131-3 programming software offers greatly enhanced functionality allowing you to connect drives, Operator Interfaces and I/O to a network and configure how they exchange data. SyPTPro allow you to program in your choice of three different languages, with a real-time multi-tasking environment. It contains a suite of monitoring and diagnostics features that help you to reduce the time it takes to develop your programmes and allows you to get your machine into service faster.

SyPTPro may be used to program Unidrive SD with SM-Applications and SM-Application Lite option modules (and Mentor II DC Drive with MD29 option modules).

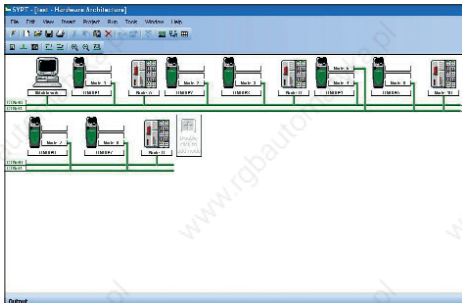

Industrial Network – SyPTPro allows you to configure a single drive or a complete drive system connected to a network. CTNet is an industrial network designed to be deterministic, robust and tolerant to noise and interference. An OPC server is available free of charge from your local Control Techniques Drive Centre or Distributor.

Programming – SyPTPro allows you to program in your choice of three programming languages; Function block diagram, Ladder diagram and DPL (Drive Programming Language). And offer a multi-tasking environment where the tasks are scheduled according to the required speed of execution or triggered by events.

Function Block – SyPTPro incorporates an IEC61131-3 function block diagram editor, and comes with a library of more than 250 function blocks for both simple and complex functions. These embed years of application experience to make your software easier to write and easy to re-use. Additionally you can create a library of your own function blocks or update your library via our online user resources – SyPTPro.com. All function blocks may be used in any of the three languages.

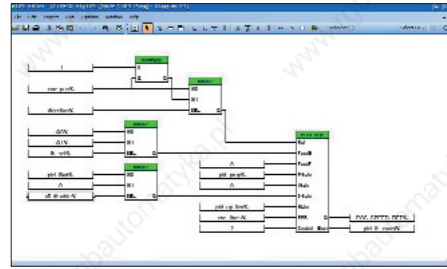

Ladder – SyPTPro incorporates an IEC 61131-3 Ladder language editor. This form of programming will be familiar to all PLC programmers and is the ideal format for sequencing and I/O control.

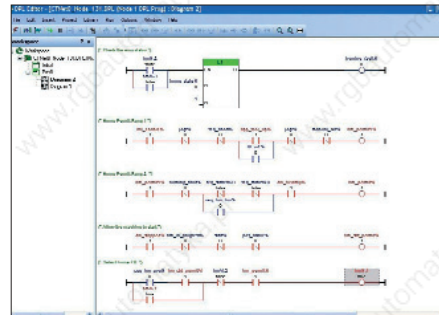

DPL – Drive Programming Language is a structured text language, as easy to use as BASIC, incorporating many standard constructs, such as IF, THEN, ELSE, and FOR, NEXT loops. DPL is ideal for initialising, configuration and general programming.

Diagnostics and debugging – Good diagnostics are essential and ensure:

- Software development time is minimised
- Commissioning time is reduced
- Down time is cut dramatically

SyPTPro contains a suite of diagnostic tools that help you to find problems with the system or software quickly and easily. When connected on-line, SyPTPro shows you live real-time views of variables in Function Block Diagrams, Ladder Diagrams and DPL, and allows you to execute program stepping and breakpoints.

System Watch Window – Allows you to monitor real-time variables and parameters from a single drive or multiple drives.

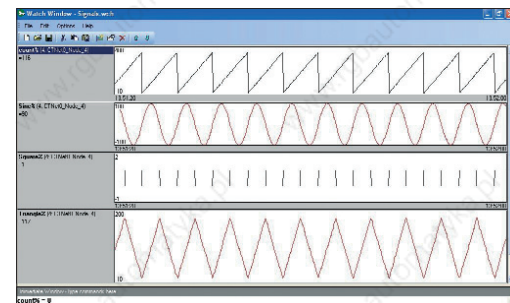

POWERTOOLS PRO WITH UNIDRIVE AND SM-EZ MOTION

The PowerTools Pro software in combination with the SM-EZMotion module enables users to fully realise the motion control power of the Unidrive . A familiar Microsoft® Windows™ interface provides operators and machine builders with the tools needed to access everything required for complete servo control – PLS, Queueing, Analog-In, User Variables, High-Speed Capture, Electronic Gearing, Multiple Profile Summation, S-Curve Accel and Decel, Program multitasking, Synchronised motion, and more.

Developing applications with PowerTools Pro is an easy “five-step, top-down” process that quickly gets your applications running. The five task areas that need to be completed in order are found in the Hierarchy View – Hardware, Setup, I/O Setup, Motion, Programs and Network. Some areas may not need completing, as some applications, such as a “flying cutoff” may not require “programming” nor network parameters to operate.

- Programming software for the SM-EZMotion module that gets applications up and running quickly, from the simple to the complex
- Hierarchy View provides for an easy, flexible, and powerful programming environment
- Familiar Windows™-based processes simplify entering data
 - “Fill-in-the-Blank” Values
 - “Point and Click” Radio Buttons
 - “Scrolling” Menu Selections
 - “Drag and Drop” parameters and I/O assignments
- Online Watch window for diagnostic, fault, and parameter updates.



PowerTools Pro WITH SM-EZMotion
OR VISIT
www.controltechniques.com/download.htm

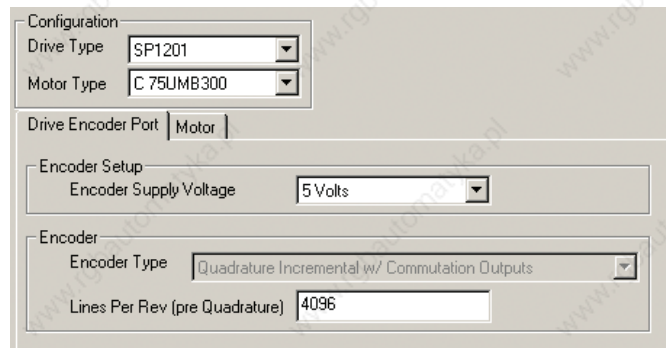

An unexpanded Hierarchy View is shown on the left-hand side of the SM-PowerTools startup screen.

User Units

User Units are the first item under Setup on the PowerTools hierarchy. User units deliver high resolution performance and ease of use. Motion can be programmed in any units that the user desires. Setup the 32-bit data resolution for position, velocity, and acceleration data one time and the rest is done for you. Select from optional time scales for Velocity and Acceleration units.

Programs

Combine program flow and motion instructions to create fully customised user programs up to 1,000 lines of code. Use conditional branching, wait for, program calls, formulas, user variables, and numerous motion instructions to solve your complex applications. Easily create programs, such as the drill head positioning program below, by dragging and dropping, or typing program instructions, variables, I/O, and formula operands into your program screen. Use the SM-EZMotion module to run one program at a time, or up to four programs simultaneously!

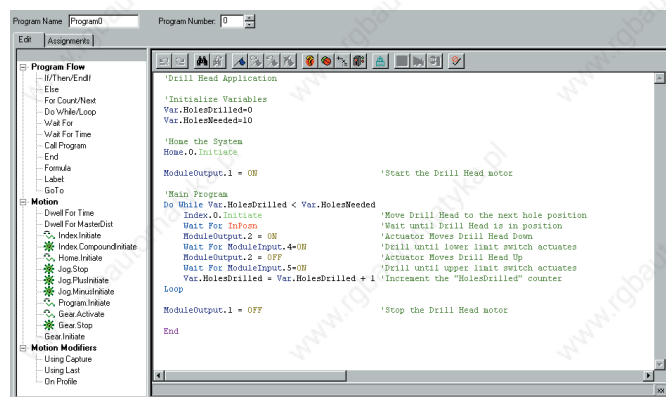

Expanded Hierarchy View

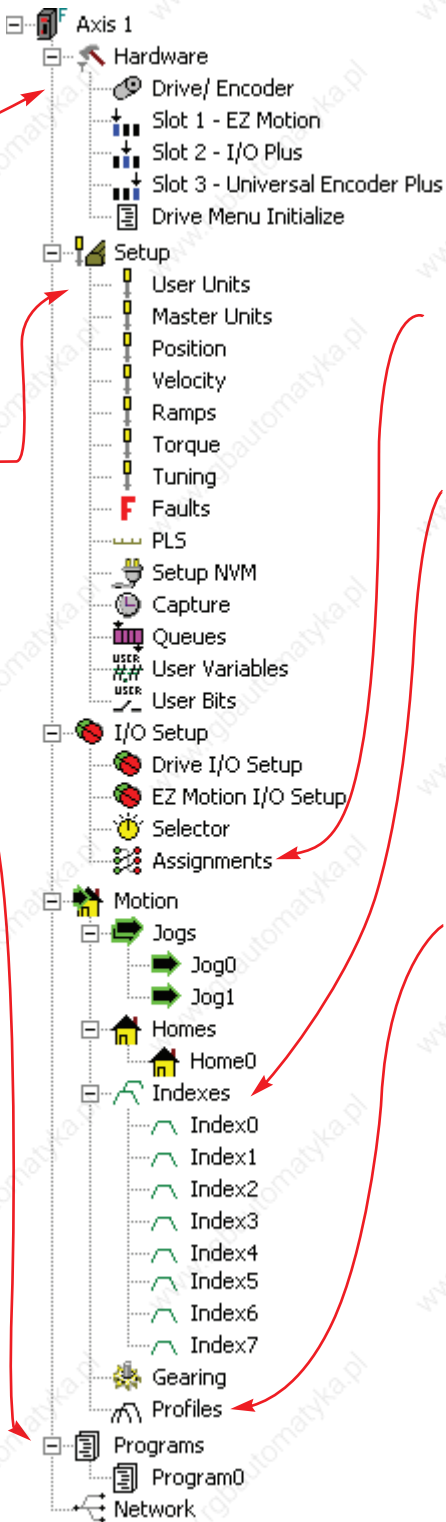

Source	Assigned to	Polarity	Destination	Set From	Polarity
InitiallyActive	PLS.0.PLSEnable	Active On	DriveOutput.1	Index.0.AIVel	Active On
Index	Index.0.AIVel	Active On	Index	Index.0.Initiate	Active On
Cut	Index.0.CommandComplete	Active On	Retract	PLS.0.Status	Active On
PLS	PLS.0.Status	Active On	Home	Index.1.Initiate	Active On
Inputs	DriveInput.1	Active On	Home0	Home.0.Initiate	Active On
DriveInput.2	Home.0.SensorTrigger	Active On	Home.0.SensorTrigger	DriveInput.1	Active On
DriveInput.3	MasterAxis.DefineHome	Active On	PLS	DriveInput.2	Active On
	Stop	Active On	PLS	InitiallyActive	Active On
			Flamps	Stop	Active On
			Master	MasterAxis.DefineHome	Active On

Assignments

Use our "Virtual Wiring" to create programs right out of the box, without writing a "line of code." For example, the assignment screen below shows how easily a flying cutoff routine can be created.

Indexes

Setting up indexes is easily accomplished by filling in the screen's blanks to create an index profile. Select from Incremental, Absolute, Registration, or Rotary Plus and Minus types. Choose the time base of the index by selecting either realtime or synchronised to a master.

Example Index screen

Profiles

This function allows the user to simultaneously execute any two motion types together resulting in a summed profile (i.e. Gear + Index, Jog + Index, Index + Index, etc.). Summing profiles is ideal for phasing applications such as Random Infeed, Rotary Knife, Merge Conveyor, and any number of other applications.

```

Gear.initiate on Profile.0
Index.0.Initiate on Profile.1
Wait for Index.0.CommandComplete
Wait for Time .25 'second
Index.1.Initiate on Profile.1
    
```

Multiple Profiling

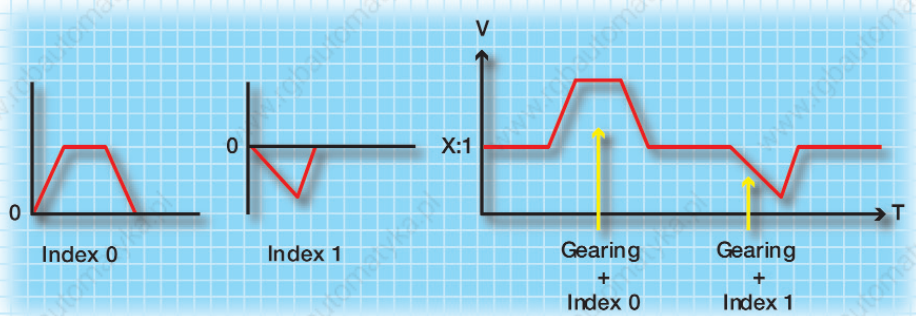

solutions

FLYING SHEAR CONTROL

The Flying Shear is a common industrial application for cutting a continuous product to a set length while at line speed. This means that the main production process is not interrupted, and so machine productivity is maximised.

Typical applications include various types of cut to length machines, depositors, punches, product inspection, or any other process where synchronisation at line speed is required.

Standard Features

- Easy configuration
- Hardware and software limits
- Manual jog functions
- Several homing modes
- High speed output is used to initiate the cut
- Registration capture
- Batch control functions
- Dynamic motion profile changes on the fly
- Engineering units are used for programming
- Units are defined for the master and slave axis as the number of encoder counts per unit. These are entered as a numerator and denominator to allow fractional values
- Resolution of the 'cut-length' may be entered to within 0.001 units
- Profile optimisation reduces the machines mechanical stress: The return profile is calculated to operate at the slowest speed and acceleration rate, and yet with sufficient time to achieve the next cut, either triangular or trapezoidal profiles are used
- Parallel and angled carriage applications are handled

Flying Shear – Inline

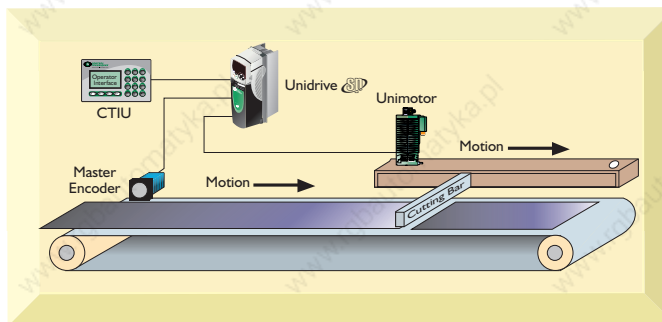

Flying Shear – Angled

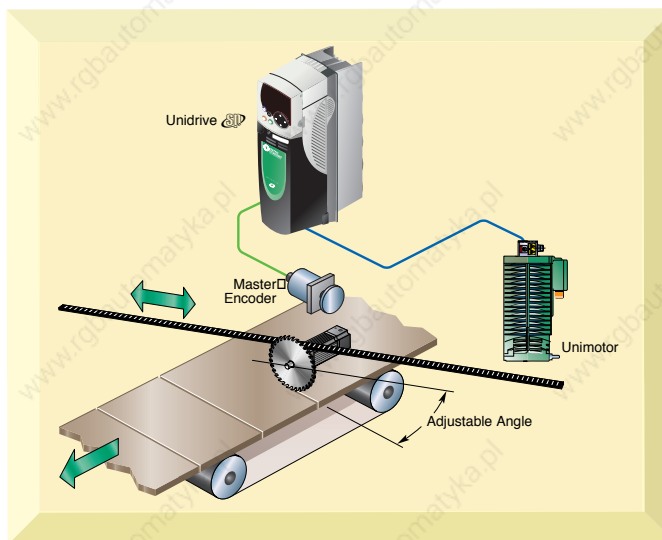

Solutions Software	Order Code
Flying Shear Control	SSP-4000-0020

Accessories

- Fieldbus communication options: Modbus, DeviceNet, CANopen, PROFIBUS DP, INTERBUS, Ethernet and CTNet.
- Expanded I/O option
- CTNet Modular I/O
- Range of HMIs
- Dynamic Braking
- Regenerative Braking

Unimotor EZ/UM

OVERVIEW

Unimotors are very smooth, low cogging brushless AC servo motors from Control Techniques. They are 3 phase, 6 or 8 pole, permanent magnet motors exhibiting a sinusoidal back EMF characteristic. Standard options include brakes, fans, and cables for connectorized motor power and feedback, including incremental, resolver and Sin/Cos Absolute. The unique 'finned' motor housing is a high-strength aluminum alloy casting that improves heat dissipation by conduction, radiation and convection. This medium inertia motor optimises torque output and reduces cogging torque. The compact design gives increased torsional stiffness. Laminations and coils are optimised both for high efficiency and to provide low harmonic distortion in the airgap flux.

Specification

Standard motors have UL and CAN/CSA recognised Insulation System to class. The CTD/IS/2000/01 insulation system number on the motor number plate, together with the symbol, denotes this. Earlier motors may display this information on a separate label on the rear cover.

If the UL symbol has "E215243" underneath, then this indicates full motor recognition.

Machinery Directive 89/392/EEC amended to 98/37/EC

Low Voltage Directive 73/23/EEC

- EN 60034 General requirements for rotating electrical machinery
- EN 60034-1 Duty: S1 Continuous
Storage: -15° to 40°C Operating: Min ambient 0°C; max ambient 40°C
Less than 1000m altitude
Relative humidity: 90% Non condensing
- EN 60034-5 Degree of Ingress protection: IP65S (with mating connector & cable fitted)
- EN 60034-6 Method of cooling: free circulation, free convection
- EN 60034-7 Flange mounted: horizontally or vertically
- EN 60034-8 Terminal markings: U V W
- EN 60034-11 Thermal protection: PTC thermistor; 165°C TPI11 (Not SL variants)
- EN 60034-18 Insulation system: Class H 600V, UL number E214439
- EN 60072 Dimensions and output for rotating electrical machines
- EN 60072-1 Type N (Customer variants)
- ISO 1940-1 Balancing: to G6.3, (ISO8821 half key convention)

Equipment is not deemed suitable for use in an explosive atmosphere.







This product has been designed to be operated with Control Techniques drives and must not be put into service unless the machinery into which it is to be incorporated has been declared in conformity with the provisions of the machinery directive.

NAMEPLATE

Values shown for K_E ; K_T , I_0 , stall/rated torque ($M_{0/N}$) and power (P_N) are for motor at full maximum rating in a 40°C ambient.

$K_{E(NOM)}$ is the motor's back e.m.f. at 20°C.

3ø, 8pole, PM Servomotor 190UMD201CBAAA SN 347088 VPWM 380 /480 Vac Brake 24 Vdc; 1.1 A  MADE IN EC, NOV 02 	 $K_E (NOM)$ 147 V/krpm \oplus $M_{0/N}$ 78.0 /60.0 Nm; P_N 12.6kW $K_T (HOT)$ 2.24 Nm/A; $I_0 (HOT)$ 34.8 A IP65S; 0-40°C / Δ 125°C; T_{CW} 632s n_N /MAX 2000 /3265 rpm; f-b resolver  CTD/ IS/ 2000/01  EN60034
--	--

3ø, 8pole, PM Servomotor

Indicates number of poles. This motor has 8 poles or 4 pole pairs. Electrical frequency = (rpm/60) x (number of pole pairs)

190UMD201CBAAA

Motor type number – ref. Ordering information

VPWM 380 /480 Vac For use with a VPWM (Voltage Pulse Width Modulation) Drive with supply voltage as indicated.

Brake 24 Vdc; 1.1 A Brake supply requirements

$K_E (NOM)$ 147V/krpm K_E ac Volts per 1000rpm with motor at 20°C

$M_{0/N}$ 78.0 /60.0 Nm M_0 (Stall torque) = 78.0Nm; M_N (rated torque @ nominal speed rpm) = 60.0 Nm

P_N 12.6kW P_N (Power @ nominal speed) = 12.6 kW
K_T (HOT) 2.24 Nm/A; I₀ (HOT) 34.8 A K_T (Torque Constant) at maximum operating temperature = 2.24 Nm/A I₀(HOT) (Stall Current at maximum operating temperature) = 34.8 A

IP65S Ingress Protection = IP65S (excludes front shaft seal)

Insulation Class [®] Windings are built to Class H standard (180°C) Motor will have further ambient and Δt restrictions.

0-40°C / Δ125°C Ambient temperature range / (delta) winding temperature increase above ambient (at full rating)

T_{CW} 632s Thermal Time-constant of copper winding with respect to iron laminations.

n_N /MAX 2000 /3265 rpm n_N (nominal speed) = 2000 rpm / n_{MAX} (maximum speed) = 3265 rpm (at maximum drive supply voltage and no load or low torque)

Note: maximum speed given for motor includes limit of feedback device, but excludes drive limits.

f-b resolver Feedback Device is a resolver.

Other Devices are as per the following table.

Feedback Type	Name
Resolver	"resolver"
Incremental 4096	"4096ppr"
Incremental 1024	"1024ppr"
Incremental 2048	"2048ppr"
CT Coder & SLM3	"SLM3"
Sincos SRM50 1024	"SRM50"
Sincos SRS50 1024	"SRS50"

CE EN60034

CE (Conformité Européenne) mark and reference number.
 Note: A "Declaration of Incorporation" is contained within the Unimotor Installation Guide that accompanies each motor.

UM/EZ Unimotor Order Code

95 UM B 30 0 C A C A A

Inertia: **A** = Standard, **B** = High

Flange Mounting: **A** = IEC

Feedback Device:

C = Incremental Encoder

R = Sin / Cos multi turn Encoder

S = Sin / Cos single turn Encoder

A = Resolver

Shaft Key: **A** = With Key, **B** = No Key

Connection Type: **C** = Connectors

Brake: **0** = None, **1** = 24VDC

Rated Speed: **20** = 2,000, **30** = 3,000, **40** = 4,000 rpm,
60 = 6,000 rpm

Stator Length: A, B, C, D, E

Unimotor **UM** = 460V **EZ**=230V

Frame Size: **75, 95, 115, 142, 190**

Inertia: **A** = Standard, **B** = High

Flange Mounting: **A** = IEC

Feedback Device:

C = Incremental Encoder

R = Sin / Cos multi turn Encoder

S = Sin / Cos single turn Encoder

A = Resolver

Shaft Key: **A** = With Key, **B** = No Key

Connection Type: **C** = Connectors

Brake: **0** = None, **1** = 24VDC

Rated Speed: **20** = 2,000, **30** = 3,000, **40** = 4,000 rpm,
60 = 6,000 rpm

Stator Length: A, B, C, D, E

Unimotor **UM** = 460V **EZ**=230V

Frame Size: **75, 95, 115, 142, 190**

Dimensions (mm) – Unimotor UM and EZ

Frame Size	75		95		115			142		190			
	B	D	B	D	B	D	E	B	D	A	B	C	D
Dimension / Winding													
A Length Overall	241	301	252	312	272	332	362	255	315	273	327	381	435
A Length Overall (Braked)	271	331	282	342	302	362	392	315	375	327	381	435	489
B Body Length	176	236	187	247	207	267	297	190	250	210	264	318	372
B Body Length (Braked)	206	266	217	277	237	297	327	250	310	264	318	372	425
C Flange Square	75	75	95	95	115	115	115	142	142	190	190	190	190
D Flange Thickness	7	7	9	9	11	11	11	12.3	12.3	14.5	14.5	14.5	14.5
E Pilot Diameter [J6]	60	60	80	80	95	95	95	130	130	180	180	180	180
F Pilot Thickness	2.4	2.4	2.9	2.9	2.9	2.9	2.9	3.4	3.4	4	4	4	4
G Power to Connector C/L	61	61	62.5	62.5	66	66	66	80	80	0	0	0	0
H Bolt Circle Diameter [H14]	5.8	5.8	7	7	10	10	10	12	12	14.5	14.5	14.5	14.5
J Bolt Hole p.c.d	75	75	100	100	115	115	115	165	165	215	215	215	215
K Overall Height	126	126	146	146	166	166	166	193	193	260	260	260	260
L Signal Connector Height	107	107	117	117	127	127	127	140	140	161.1	161.1	161.1	161.1
M Signal Connector Height (SLM)	88	88	98	98	108	108	108	121	121	0	0	0	0
N Shaft Length (Front)	30	30	40	40	40	50	50	50	50	58	58	58	58
P Shaft Diameter (Front) [K6-190 only]	14	14	19	19	19	24	24	24	24	32	32	32	32
R Shaft Key Length	22	22	32	32	32	40	40	40	40	49	49	49	49
S Shaft Key Height	15.9	15.9	21.4	21.4	21.4	26.9	26.9	26.9	26.9	35	35	35	35
T Shaft Key to Shaft End	3	3	3	3	3	4	4	4	4	3.1	3.1	3.1	3.1
V Shaft Key Width	5.0	5.0	6	6	6	8	8	8	8	10	10	10	10

Dimensions (mm) – Unimotor UM and EZ

Frame Sizes 75 - 142

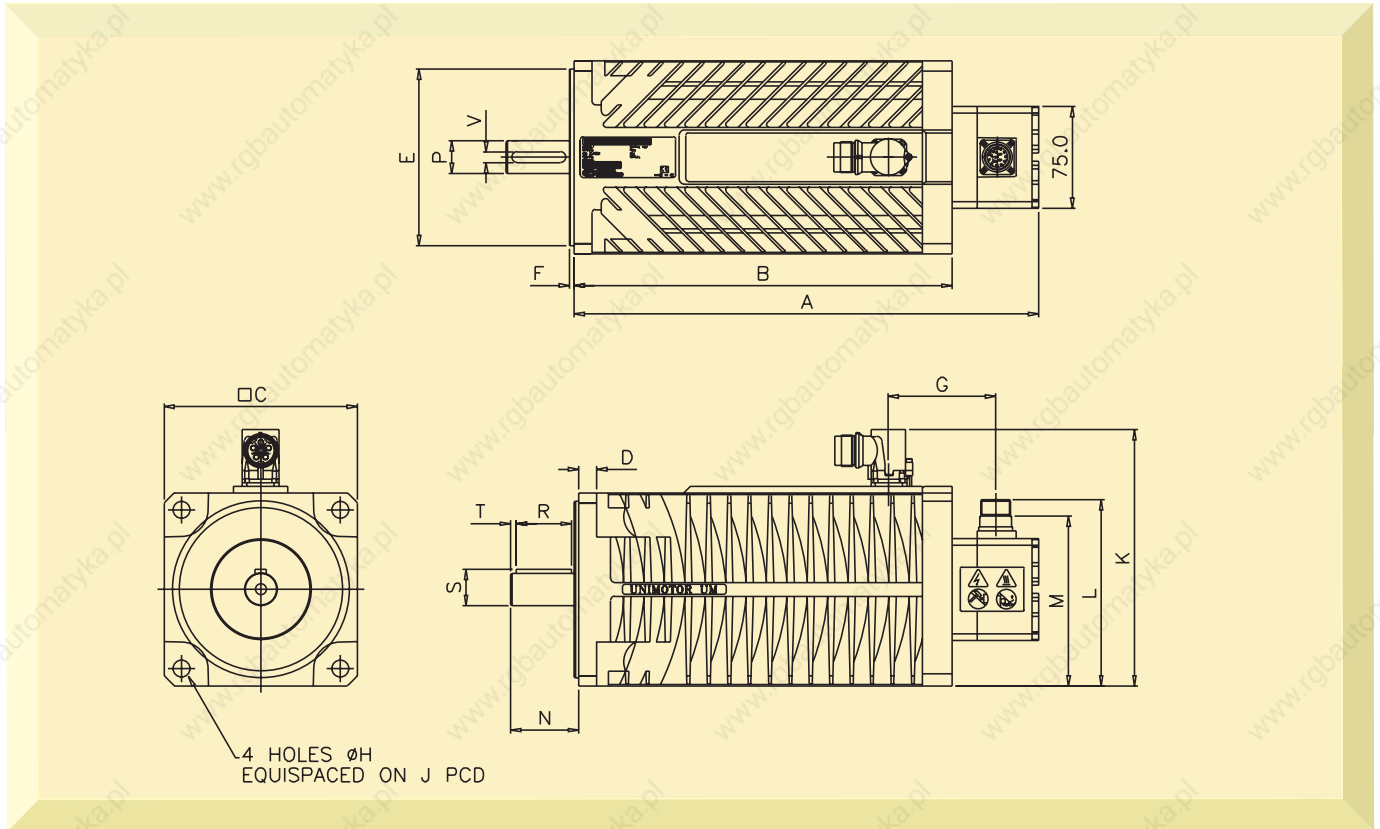

Frame Size 190

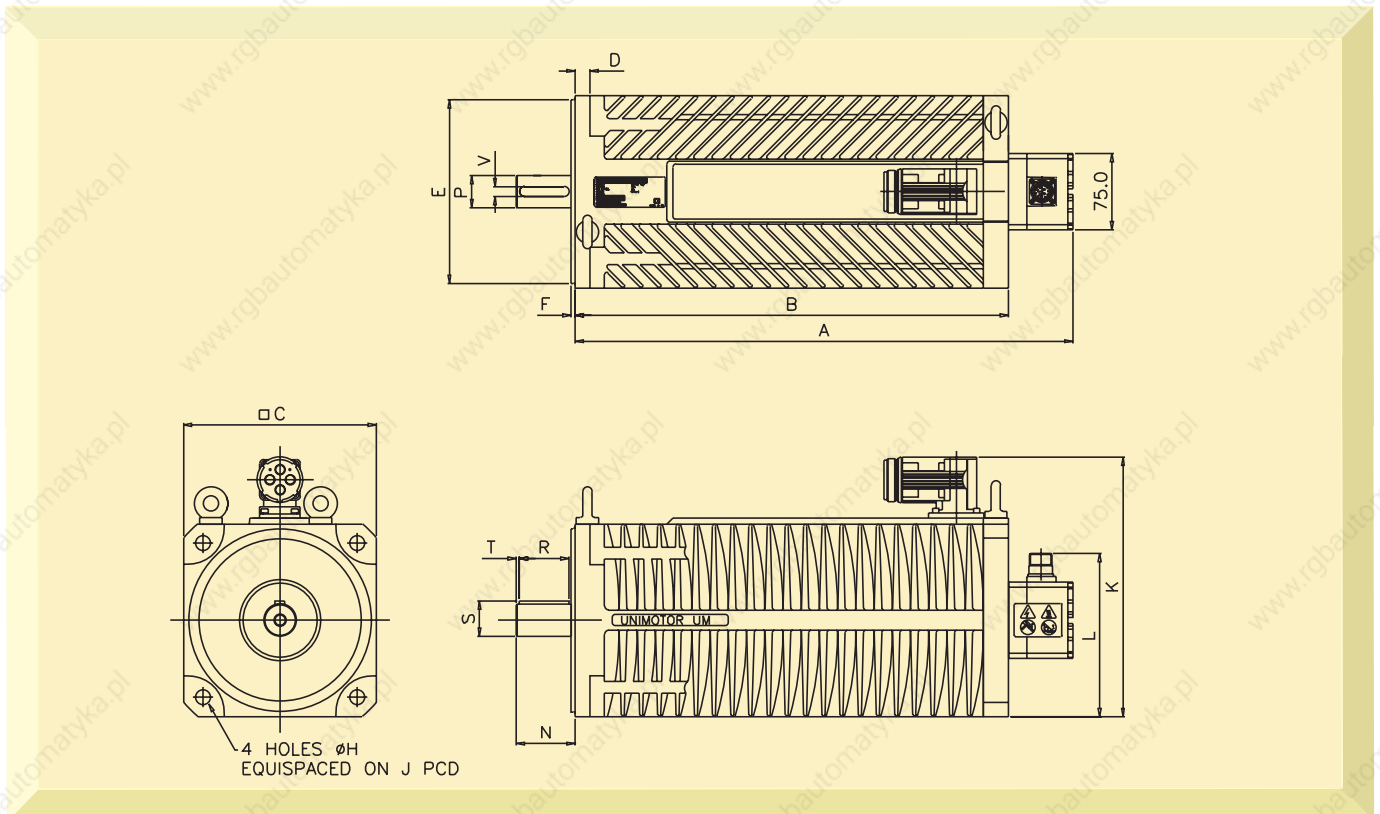

Unimotor UM servo motor technical specifications

For 3 Phase VPWM Drives 380 - 480Vrms

Unimotors with Encoder Feedback
 $\Delta t = 100^{\circ}\text{C}$, 40°C ambient

Stall torque; stall current and power relate to maximum continuous operation in a 40°C ambient
 All data subject to +/-10% tolerance

Motor Frame Size (mm)		75				95					115					142					190			
All Speeds	Frame Length	A	B	C	D	A	B	C	D	E	A	B	C	D	E	A	B	C	D	E	A	B	C	D
Continuous Stall Torque (Nm)		1.2	2.2	3.1	3.9	2.3	4.3	5.9	7.5	9.0	3.5	6.6	9.4	12.4	15.3	6.3	10.8	15.3	19.8	23.4	21.8	41.1	58.7	73.2
Peak Torque (Nm)		3.6	6.6	9.3	11.7	6.9	12.9	17.7	22.5	27.0	10.5	19.8	28.2	37.2	45.9	18.9	32.4	45.9	59.4	70.2	65.4	123	176	219
High Inertia (kgcm^2)		1.2	1.6	2.1	2.5	3.5	4.5	5.6	6.7	7.8	9.7	12.0	14.3	16.6	18.8	21.6	28.0	34.3	40.7	47.0	93.5	141	188	235
Standard Inertia (kgcm^2)		0.6	1.0	1.5	1.9	1.4	2.5	3.6	4.7	5.8	3.2	5.5	7.8	10.0	12.3	7.8	14.1	20.5	26.8	33.1	50.0	97.0	144	191
Winding Thermal Time Const.(sec)		81	74	94	100	172	168	183	221	228	175	185	198	217	241	213	217	275	301	365	240	242	319	632
Maximum Cogging (Nm)		0.02	0.03	0.04	0.05	0.03	0.06	0.08	0.10	0.13	0.06	0.10	0.14	0.18	0.21	0.09	0.16	0.23	0.30	0.35	0.30	0.54	0.72	0.99
Rated Speed 2000 (rpm)		Kt (Nm/A) 2.40 Ke (V/krpm) 147																						
Rated Torque (Nm)		1.1	2.1	3.0	3.8	2.2	4.0	5.5	6.9	8.2	3.2	6.1	8.7	10.8	14.0	5.9	10.3	14.6	18.4	21.3	20.0	36.9	50.4	54.7
Continuous Stall Current (A)		0.5	1.0	1.3	1.7	1.0	1.8	2.5	3.2	3.8	1.5	2.8	4.0	5.2	6.4	2.7	4.5	6.4	8.3	9.5	9.1	17.2	24.5	30.5
Rated Power (kW)		0.23	0.44	0.63	0.80	0.46	0.84	1.15	1.45	1.72	0.67	1.28	1.82	2.26	2.93	1.24	2.16	3.06	3.85	4.46	4.19	7.73	10.6	11.5
R (ph-ph) (Ohms)		144	48.2	25.0	15.7	59.0	17.0	9.90	6.00	4.30	27.8	8.55	4.55	2.96	2.17	12.5	3.60	2.10	1.35	0.98	1.80	0.56	0.33	0.23
L (ph-ph) (mH)		214	99.2	59.2	44.7	131	54.5	36.5	25.6	18.9	94.6	40.5	25.7	18.6	14.7	58.0	29.8	18.7	13.6	10.7	28.1	13.0	8.90	6.30
Rated Speed 3000 (rpm)		Kt (Nm/A) 1.6 Ke (V/krpm) 98.0																						
Rated Torque (Nm)		1.1	2.0	2.8	3.5	2.0	3.9	5.4	6.8	8.1	3.0	5.5	8.1	10.4	12.6	5.4	9.0	12.2	15.8	18.0	19.2	33.0	35.0	36.8
Continuous Stall Current (A)		0.8	1.4	2.0	2.5	1.5	2.7	3.7	4.7	5.7	2.2	4.2	5.9	7.8	9.6	4.0	6.8	9.6	12.4	14.7	13.7	25.7	36.7	45.8
Rated Power (kW)		0.35	0.63	0.88	1.10	0.63	1.23	1.70	2.14	2.54	0.94	1.73	2.54	3.27	3.96	1.70	2.83	3.83	4.96	5.65	6.03	10.4	11.0	11.6
R (ph-ph) (Ohms)		60.8	20.1	10.5	7.5	24.5	6.80	4.00	2.50	2.00	12.6	3.86	2.02	1.40	1.10	5.63	1.72	0.94	0.61	0.44	0.79	0.30	0.14	0.09
L (ph-ph) (mH)		98.4	41.8	27.6	19.7	57.9	24.3	15.5	10.9	8.50	43.1	18.6	11.4	8.60	7.40	31.0	13.3	8.30	6.10	4.80	13.2	6.11	3.60	2.46
Rated Speed 4000 (rpm)		Kt (Nm/A) 1.20 Ke (V/krpm) 73.5																						
Rated Torque (Nm)		1.0	1.7	2.3	2.9	1.8	3.0	4.0	4.9	5.7	2.5	4.7	6.3	7.5	8.7	3.6	7.0	8.9	10.7	12.2	▲	▲	▲	N/A
Continuous Stall Current (A)		1.0	1.9	2.8	3.3	2.0	3.5	5.0	6.3	7.5	3.0	5.5	7.9	10.4	12.8	5.3	9.0	12.8	16.5	19.5				
Rated Power (kW)		0.42	0.71	0.96	1.21	0.75	1.26	1.68	2.05	2.39	1.05	1.97	2.64	3.14	3.64	1.51	2.93	3.73	4.48	5.11				
R (ph-ph) (Ohms)		36.8	10.5	6.30	4.20	12.7	4.08	2.10	1.50	1.03	6.91	2.14	1.16	0.73	0.57	3.12	1.00	0.53	0.35	0.24				
L (ph-ph) (mH)		54.9	24.8	14.9	10.8	31.5	13.6	8.50	6.30	4.80	23.5	10.2	6.60	4.70	3.90	17.6	7.50	4.70	3.60	2.70				
Rated Speed 6000 (rpm)		Kt (Nm/A) 0.80 Ke (V/krpm) 49.0																						
Rated Torque (Nm)		0.9	1.6	2.1	2.6	1.3	2.1	2.8	3.3	3.7	2.2	4.0	5.1	▲	N/A	2.9	4.5	▲	▲	N/A				
Continuous Stall Current (A)		1.5	2.8	3.9	4.9	2.9	5.4	7.4	9.4	11.3	4.4	8.3	11.8			7.9	13.5							
Rated Power (kW)		0.57	1.01	1.32	1.63	0.82	1.32	1.76	2.07	2.32	1.38	2.51	3.20			1.82	2.83							
R (ph-ph) (Ohms)		15.0	5.00	2.66	1.90	5.45	1.82	1.05	0.62	0.48	3.1	0.97	0.50			1.42	0.46							
L (ph-ph) (mH)		24.0	10.6	6.80	4.80	14.1	6.00	3.80	2.70	2.10	15.54	4.81	2.94			7.72	3.44							

N/A Not Available

▲ Consult factory

The information contained in this specification is for guidance only and does not form part of any contract
 Control Techniques have an ongoing process of development and reserve the right to change the specification without notice.

Unimotor EZ servo motor technical specifications

For 3 Phase VPWM Drives 200 - 240Vrms

Motor Frame Size (mm)		75				95					115					142					190			
All Speeds	Frame Length	A	B	C	D	A	B	C	D	E	A	B	C	D	E	A	B	C	D	E	A	B	C	D
Continuous Stall Torque (Nm)		1.2	2.2	3.1	3.9	2.3	4.3	5.9	7.5	9.0	3.5	6.6	9.4	12.4	15.3	6.3	10.8	15.3	19.8	23.4	21.8	41.1	58.7	73.2
Peak Torque (Nm)		3.6	6.6	9.3	11.7	6.9	12.9	17.7	22.5	27.0	10.5	19.8	28.2	37.2	45.9	18.9	32.4	45.9	59.4	70.2	65.4	123	176	219
High Inertia (kgcm ²)		1.2	1.6	2.1	2.5	3.5	4.5	5.6	6.7	7.8	9.7	12.0	14.3	16.6	18.8	21.6	28.0	34.3	40.7	47.0	93.5	141	188	235
Standard Inertia (kgcm ²)		0.6	1.0	1.5	1.9	1.4	2.5	3.6	4.7	5.8	3.2	5.5	7.8	10.0	12.3	7.8	14.1	20.5	26.8	33.1	50.0	97.0	144	191
Winding Thermal Time Const.(sec)		81	74	94	100	172	168	183	221	228	175	185	198	217	241	213	217	275	301	365	240	242	319	632
Maximum Cogging (Nm)		0.02	0.03	0.04	0.05	0.03	0.06	0.08	0.10	0.13	0.06	0.10	0.14	0.18	0.21	0.09	0.16	0.23	0.30	0.35	0.30	0.54	0.72	0.99
Rated Speed 2000 (rpm)		Kt (Nm/A) 1.40 Ke (V/krpm) 85.5																						
Rated Torque (Nm)		1.1	2.1	3.0	3.8	2.2	4.0	5.5	6.9	8.2	3.2	6.1	8.7	10.8	14.0	5.9	10.3	14.6	18.4	21.3	20.0	36.9	50.4	▲
Continuous Stall Current (A)		0.9	1.6	2.3	2.8	1.7	3.1	4.3	5.4	6.5	2.6	4.8	6.8	8.9	11.0	4.6	7.8	11.0	14.2	16.8	15.7	29.5	42.1	
Rated Power (kW)		0.23	0.44	0.63	0.80	0.46	0.84	1.15	1.45	1.72	0.67	1.28	1.82	2.26	2.93	1.24	2.16	3.06	3.85	4.46	4.19	7.73	10.6	
R (ph-ph) (Ohms)		45.8	15.3	8.52	5.72	19.4	6.2	3.16	2.31	1.71	9.09	2.83	1.51	0.99	0.82	4.28	1.33	0.76	0.45	0.32	0.50	0.15	0.10	
L (ph-ph) (mH)		98.8	43.4	27.9	20.2	59.2	25.8	16.0	12.6	10.1	47.3	20.6	13.1	9.54	7.86	33.7	15.1	10.3	6.96	5.58	7.98	3.32	2.73	
Rated Speed 3000 (rpm)		Kt (Nm/A) 0.93 Ke (V/krpm) 57.0																						
Rated Torque (Nm)		1.1	2.0	2.8	3.5	2.0	3.9	5.4	6.8	8.1	3.0	5.5	8.1	10.4	12.6	5.4	9.0	12.2	15.8	N/A	19.2	33.0	▲	N/A
Continuous Stall Current (A)		1.3	2.4	3.4	4.2	2.5	4.7	6.4	8.1	9.7	3.8	7.1	10.2	13.4	16.5	6.8	11.7	16.5	21.3		23.5	44.2		
Rated Power (kW)		0.35	0.63	0.88	1.10	0.63	1.23	1.70	2.14	2.54	0.94	1.73	2.54	3.27	3.96	1.70	2.83	3.83	4.96		6.03	10.4		
R (ph-ph) (Ohms)		18.9	6.26	3.50	2.38	8.03	2.68	1.57	1.03	0.77	4.01	1.30	0.73	0.47	0.37	1.90	0.59	0.31	0.20		0.25	0.08		
L (ph-ph) (mH)		42.5	18.4	11.9	8.82	25.6	12.0	7.91	5.60	4.65	20.1	9.16	6.07	4.26	3.49	15.0	6.85	4.20	1.94		3.98	1.87		
Rated Speed 4000 (rpm)		Kt (Nm/A) 0.72 Ke (V/krpm) 44.0																						
Rated Torque (Nm)		1.0	1.7	2.3	2.9	1.8	3.0	4.0	4.9	5.7	2.5	4.7	6.3	7.5	▲	3.6	7.0	▲	N/A	N/A				
Continuous Stall Current (A)		1.7	3.1	4.4	5.5	3.3	6.0	8.3	10.5	12.6	4.9	9.2	13.1	17.3		8.8	15.1							
Rated Power (kW)		0.42	0.71	0.96	1.21	0.75	1.26	1.68	2.05	2.39	1.05	1.97	2.64	3.14		1.51	2.93							
R (ph-ph) (Ohms)		10.2	3.39	1.92	1.48	5.15	1.64	0.92	0.62	0.43	2.62	0.82	0.44	0.29		1.20	0.36							
L (ph-ph) (mH)		24.6	10.8	7.14	5.42	15.50	6.77	4.61	3.46	2.54	12.6	5.48	3.57	2.53		9.45	4.08							
Rated Speed 6000 (rpm)		Kt (Nm/A) 0.47 Ke (V/krpm) 28.5																						
Rated Torque (Nm)		0.9	1.6	2.1	2.6	1.3	2.1	2.8	3.3	▲	2.2	4.0	▲	N/A	N/A	2.9	▲	N/A	N/A	N/A				
Continuous Stall Current (A)		2.6	4.8	6.7	8.4	5.0	9.3	12.7	16.2		7.6	14.2				13.6								
Rated Power (kW)		0.57	1.01	1.32	1.63	0.82	1.32	1.76	2.07		1.38	2.51				1.82								
R (ph-ph) (Ohms)		4.49	1.49	0.95	0.65	2.01	0.67	0.35	0.26		0.96	0.30				0.49								
L (ph-ph) (mH)		10.7	4.73	3.10	2.33	6.41	3.01	1.77	1.40		4.80	2.09				3.96								

N/A Not available

▲ Consult factory

Control Techniques have an ongoing process of development and reserve the right to change the specification without notice.

Unidrive and Unimotor UM Selection



Unidrive  & Unimotor UM Selection

Unidrive  / Unimotor UM System Selection Guide (400V)											
Drive Model	Motor Model	Cont. Stall Torque Nm	Peak Stall Torque Nm	Rated Torque @Rated Speed* Nm	Rated Power kW	Max.* Operating Speed rpm	Encoder Resolution lines/rev	Inertia kg-cm²	Motor Ke Vrms/krpm	Motor Kt Nm/Arms	Motor Weight ^{xx} kg
SPI402	75UMB	2.1	5.3	1.9	0.61	3000	4096	1.0	98	1.6	4.3
SPI403	75UMD	3.7	9.3	3.3	1.04	3000	4096	1.9	98	1.6	5.8
SPI404	95UMB	4.2	10.4	3.8	1.19	3000	4096	2.5	98	1.6	6.1
SPI405	115UMB	6.3	15.7	5.2	1.64	3000	4096	5.5	98	1.6	8.9
SPI405	95UMD	7.1	17.7	6.5	2.03	3000	4096	4.7	98	1.6	8.8
SPI406	142UMB	10.4	22.3	8.6	2.72	3000	4096	14.1	98	1.6	12.1
SP2401	142UMB	10.4	25.9	8.6	2.72	3000	4096	14.1	98	1.6	12.1
SP2401	115UMD	11.4	28.5	9.6	3.01	3000	4096	10.0	98	1.6	12.5
SP2402	115UME	13.8	34.4	11.3	3.56	3000	4096	12.3	98	1.6	14.2
SP2403	142UMD	19.0	47.5	15.2	4.76	3000	4096	26.8	98	1.6	17.6
SP2403	190UMA	21.6	60.6	19.0	5.97	3000	4096	50.0	98	1.6	23.2
SP3402	190UMB	40.3	96.0	32.3	10.16	3000	4096	97.0	98	1.6	32
SP3403	190UMC	56.9	109.3	34.0	10.67	3000	4096	144	98	1.6	40.8
SP4401	190UMD	68.8	202.7	34.6	10.87	3000	4096	191	98	1.6	49.5

* Rated Speed = Maximum Operating Speed. Unimotors are available in alternative stack lengths A, C and E. Consult your Drive Centre/Distributor.

xx weight = low inertia, no brake

All data is at 6 kHz switching frequency

SPEED / TORQUE CURVES – UNIDRIVE AND UNIMOTOR UM 380-460 VAC

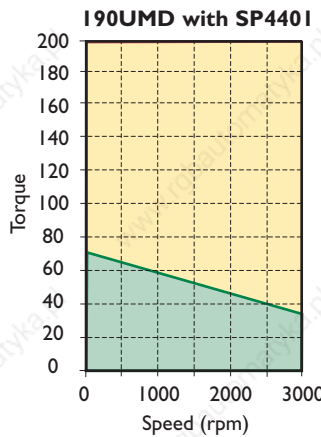
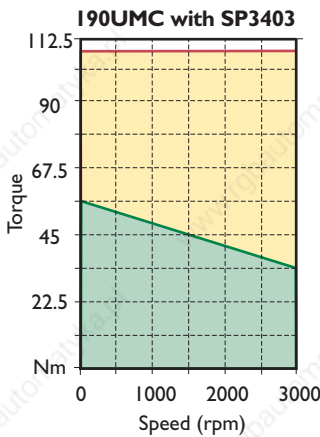
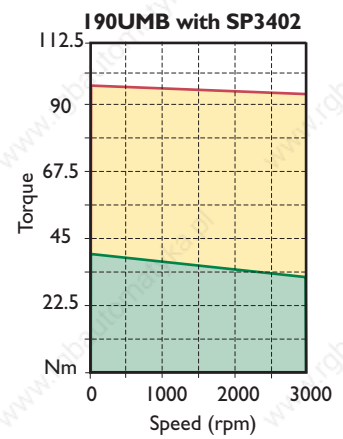
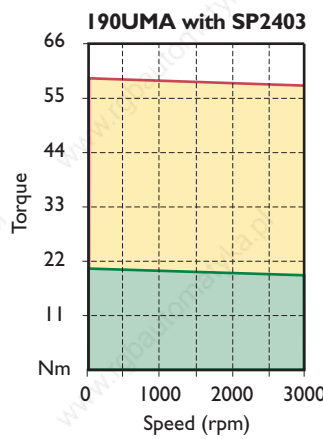
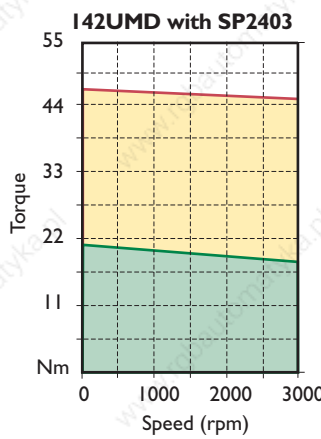
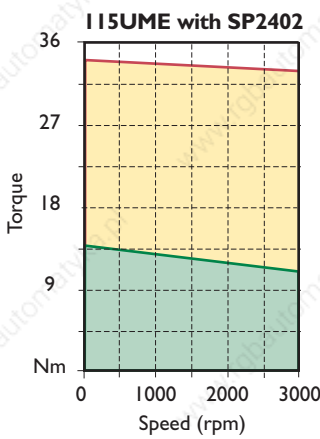
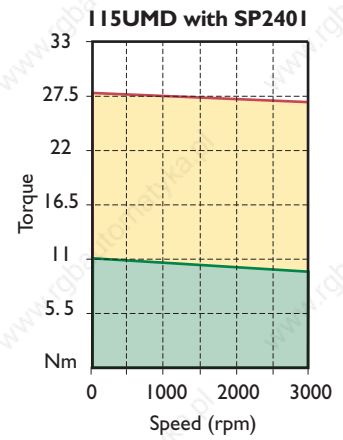
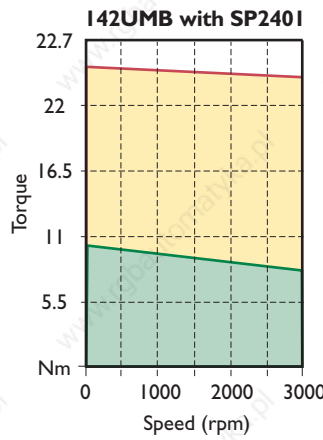
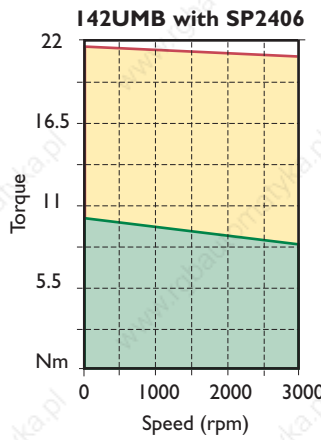
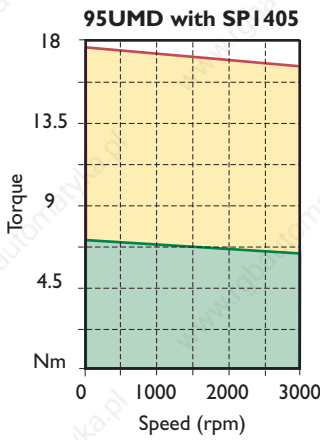
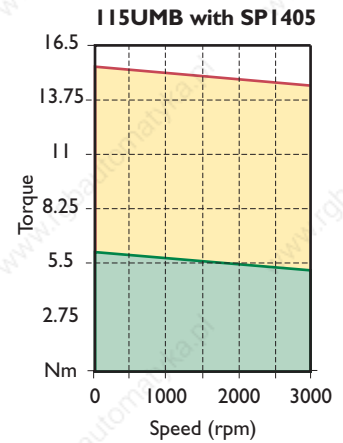
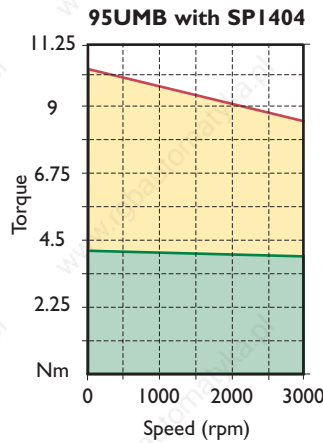
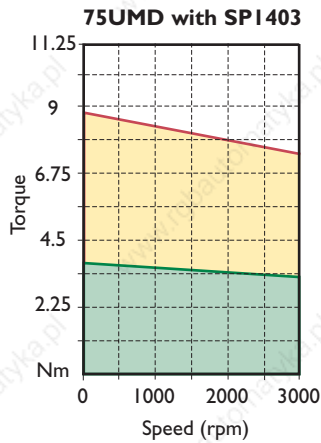
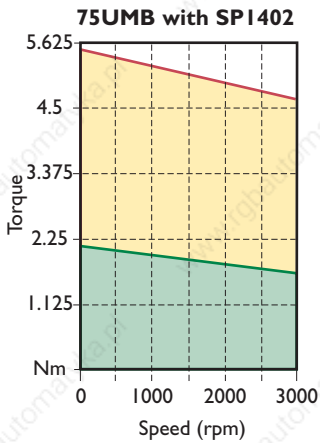

Notes

- Continuous ratings of the motor are based on 100°C motor case temperature and 40°C ambient with the motor mounted to an aluminum plate.
- Speed torque curves are based on 380-460 VAC operation at 6 kHz switching frequency. Typical peak torque ratings are 300% of continuous. For reduced peak torque applications drives with lower current ratings can be used.
- All specifications are $\pm 10\%$ due to motor parameter variations.

Unidrive and Unimotor EZ Selection

Unidrive  / Unimotor EZ System Selection (230V)											
Drive Model	Motor Model	Cont. Stall Torque Nm	Peak Stall Torque Nm	Rated Torque @Rated Speed* Nm	Rated Power kW	Max.* Operating Speed rpm	Encoder Resolution lines/rev	Inertia kg-cm ²	Motor Ke Vrms/krpm	Motor Kt Nm/Arms	Motor ^{xx} Weight kg
SP1402	75EZB	2.1	5.3	1.9	0.61	3000	4096	1.0	57	0.93	4.3
SP1203	75EZD	3.7	9.3	3.3	1.04	3000	4096	1.9	57	0.93	5.8
SP1204	95EZB	4.2	10.4	3.8	1.19	3000	4096	2.5	57	0.93	6.1
SP2201	115EZB	6.3	15.7	5.2	1.64	3000	4096	5.5	57	0.93	8.9
SP2202	95EZD	7.1	17.7	6.5	2.03	3000	4096	4.7	57	0.93	8.8
SP2203	142EZB	10.4	25.9	8.6	2.72	3000	4096	14.1	57	0.93	12.1
SP2203	115EZD	11.4	28.5	9.6	3.01	3000	4096	10.0	57	0.93	12.5
SP3201	115EZE	13.8	34.4	11.3	3.56	3000	4096	12.3	57	0.93	14.2
SP3202	142EZD	19.0	47.5	15.2	4.76	3000	4096	26.8	57	0.93	17.6
SP3202	190EZA	21.6	60.6	19.0	5.97	3000	4096	50.0	57	0.93	23.2

* Unimotors are available in alternative rated speeds, and stack lengths A, C and E. Order selections available – Consult your local Drive Centre/Distributor.

xx weight = low inertia, no brake

Data as at 6kHz switching frequency

Unimotor Holding Brake Specifications						
Motor Frame Size (Model)	Volt (DC)	Current (A)	Static Torque (Nm)	Mechanical Disengagement Time-Brake Released (ms)	Mechanical Engagement Time-Brake Holding (ms)	Added Inertia (kgcm ²)
75mm	24	0.26	2	22	24	0.03
95mm	24	0.67	6	30	20	0.2
115mm	24	0.67	12	40	10	0.49
142mm	24	0.96	20	85	30	1.28
190mm (UMA-UMB)	24	1.04	40	95	15	1.28
190mm (UMC-UMD)	24	1.04	60	120	20	2.5

SPEED TORQUE CURVES UNIDRIVE AND UNIMOTOR EZ 200-240VAC

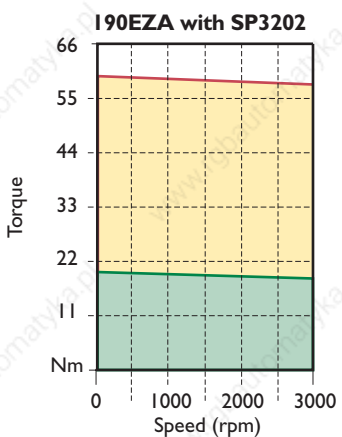
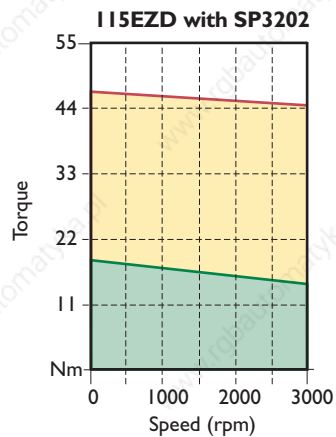
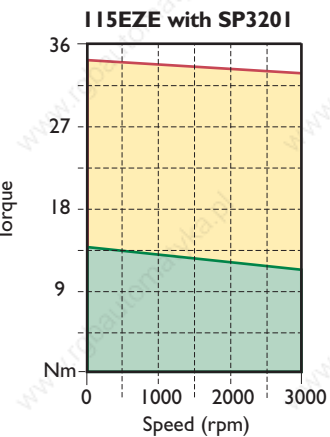
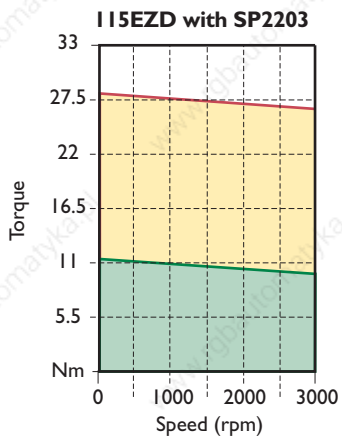
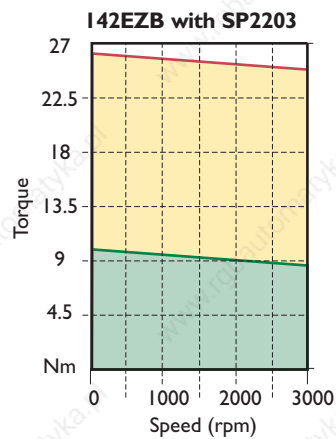
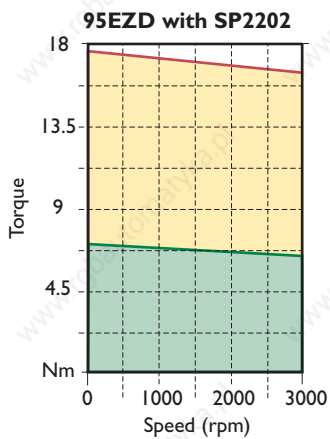
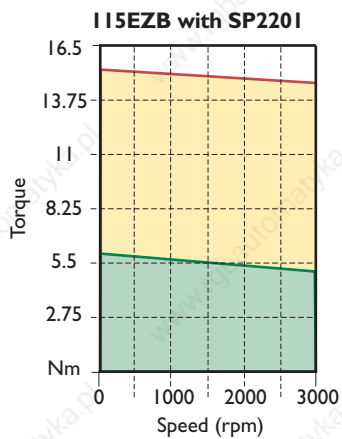
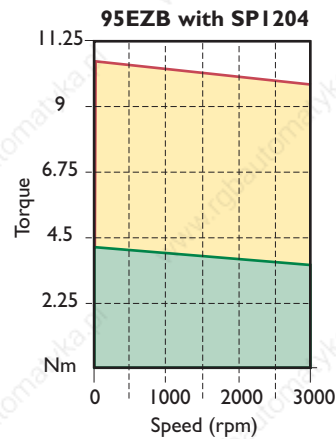
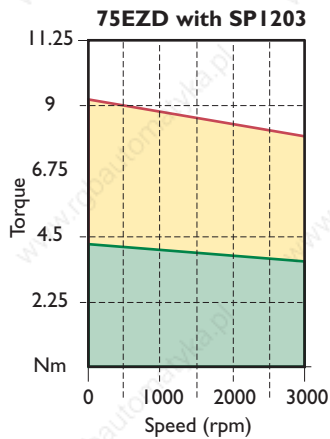
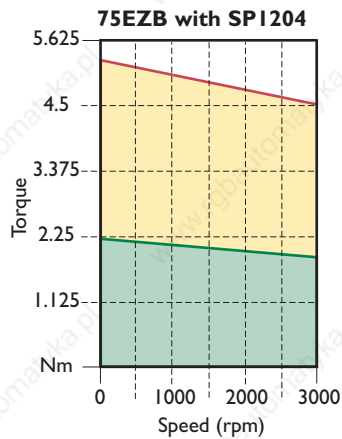

Notes

- Continuous ratings of the motor are based on 100°C motor case temperature and 40°C ambient with the motor mounted to an aluminum plate.
- Speed torque curves are based on 380-460 VAC operation at 6 kHz switching frequency. Typical peak torque ratings are 300% of continuous. For reduced peak torque applications drives with lower current ratings can be used.
- All specifications are $\pm 10\%$ due to motor parameter variations.

Unimotor UM/EZ Power Cable selection

Cable type – PS for motor without brakes, PB for motors with brake.

Jacket – B is for a PUR sheath and is the standard selection. A is for a PVC sheath to be used on the DS brake cable only.

Conductor Size – Select the conductor size according to the motors STALL CURRENT.

Include forced cooling performance if applicable.

Cables of 6mm² and above will be fitted with ring terminals only.

Ratings are for individual cables (not lashed together) in free air temperature up to 40°C - make allowances as appropriate.

Connection detail drive end – Select the correct drive end connection for the drive in use.

Connection detail motor end – Select the correct motor end connection for the motor in use.

Length – Numbers represent the required cable length in metres. Conversion cables will be limited to 0.4m only and the length is not required in the order code.

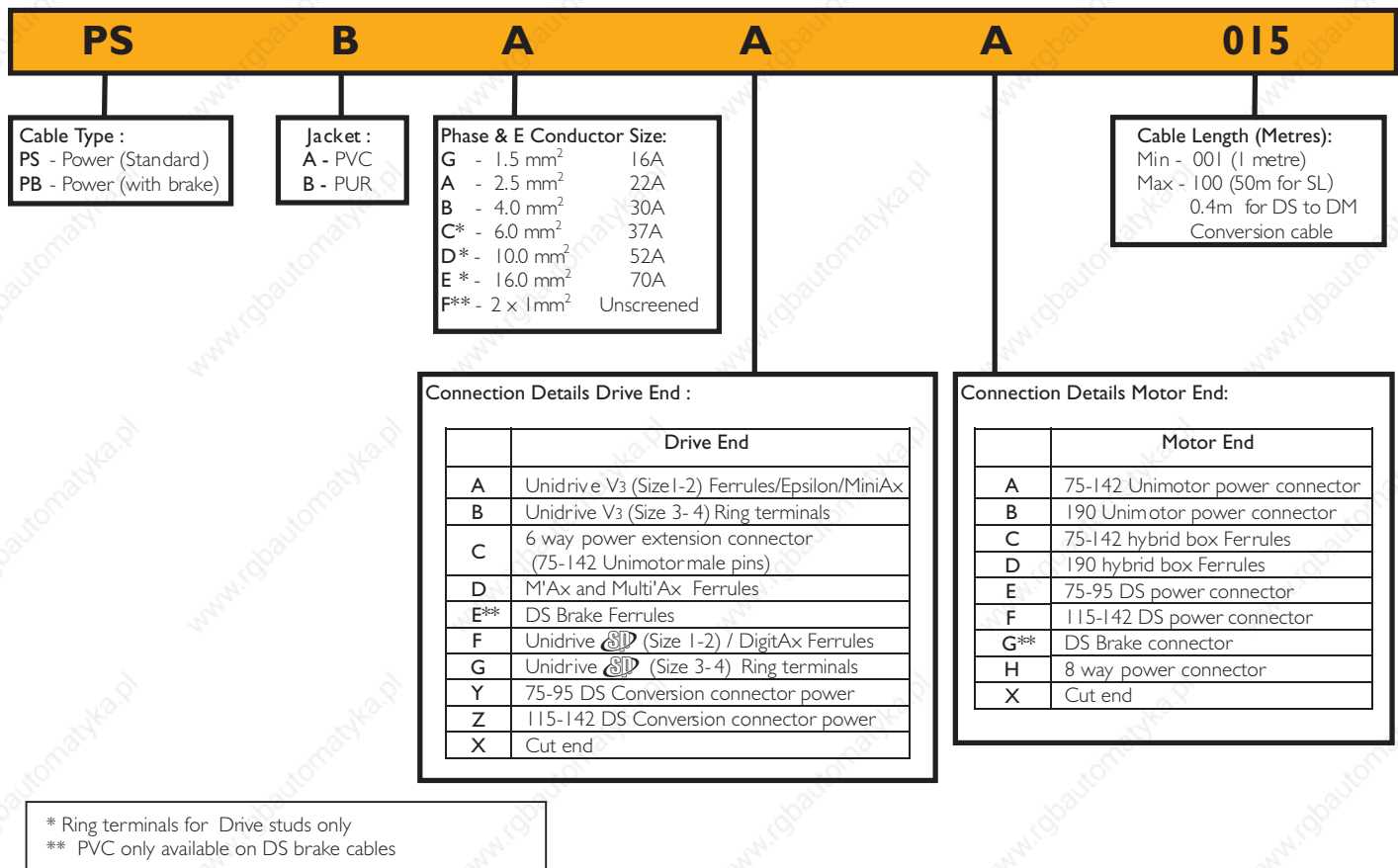

Unimotor UM/EZ Signal Cable selection

Cable type – Choose the cable type to match the feedback device.

Jacket – B is for a PUR sheath and is the standard selection.

Special options – A is for standard cable. L is for the low cost 8.5mm incremental cable.

Connection detail drive end – Select the correct drive end connection for the drive in use.

Connection detail motor end – Select the correct motor end connection for the motor feedback device in use.

Length – Numbers represent the required cable length in metres. Conversion cables will be limited to 0.4m only and the length is not required in the order code.

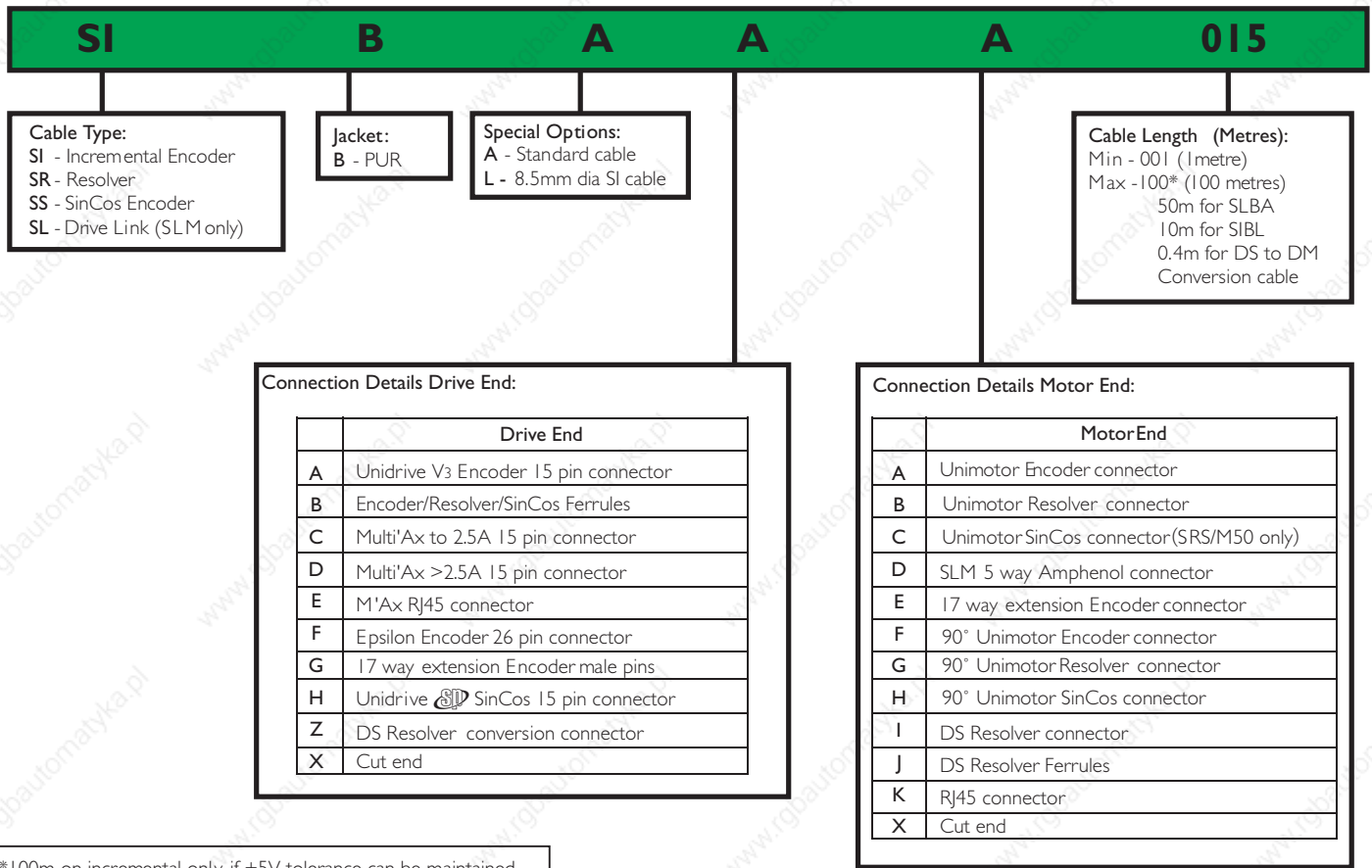

Unimotor UM/EZ Power & Signal Cable Selection

Cables

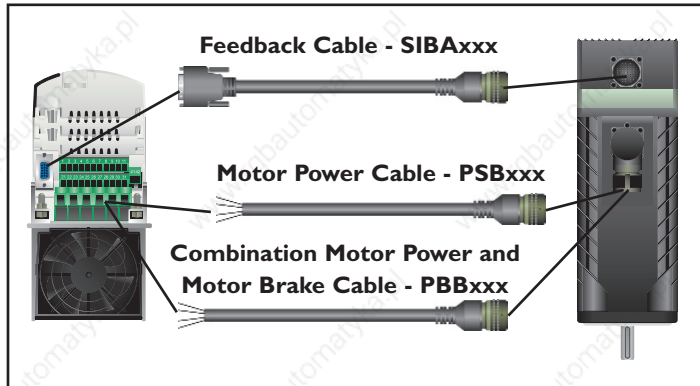

460V Unimotor UM Cable Selection

Unidrive SP Model	Motor Model	Motor Power Cable (yyy=length in metres)	Motor Power/Brake Cable (required w/all brake motors) (yyy=length in metres)	Feedback Cable ① (yyy=length in metres)
SP1402	75UMB300CACAA	PSBGFA-yyy		SIBAAA-yyy
	75UMB301CACAA		PBBGFA-yyy	
SP1403	75UMD300CACAA	PSBGFA-yyy		SIBAAA-yyy
	75UMD301CACAA		PBBGFA-yyy	
SP1404	95UMB300CACAA	PSBGFA-yyy		SIBAAA-yyy
	95UMB301CACAA		PBBGFA-yyy	
SP1405	115UMB300CACAA	PSBGFA-yyy		SIBAAA-yyy
	115UMB301CACAA		PBBGFA-yyy	
SP1405	95UMD300CACAA	PSBGFA-yyy		SIBAAA-yyy
	95UMD301CACAA		PBBGFA-yyy	
SP1406	142UMB300CACAA	PSBGFA-yyy		SIBAAA-yyy
	142UMB301CACAA		PBBGFA-yyy	
SP2401	142UMB300CACAA	PSBGFA-yyy		SIBAAA-yyy
	142UMB301CACAA		PBBGFA-yyy	
SP2401	115UMD300CACAA	PSBGFA-yyy		SIBAAA-yyy
	115UMD301CACAA		PBBGFA-yyy	
SP2402	115UME300CACAA	PSBGFA-yyy		SIBAAA-yyy
	115UME301CACAA		PBBGFA-yyy	
SP2403	142UMD300CACAA	PSBGFA-yyy		SIBAAA-yyy
	142UMD301CACAA		PBBGFA-yyy	
SP2404	190UMA300CACAA	PSBAFB-yyy		SIBAAA-yyy
	190UMA301CACAA		PBBAFB-yyy	
SP3403	190UMB300CACAA	PSBBGB-yyy		SIBAAA-yyy
	190UMB301CACAA		PBBBGB-yyy	
SP4402	190UMC300CACAA	PSBDGB-yyy		SIBAAA-yyy
	190UMC301CACAA		PBBDGB-yyy	
SP4403	190UMD300CACAA	PSBDGB-yyy		SIBAAA-yyy
	190UMD301CACAA		PBBDGB-yyy	

① Cable for incremental encoder shown. Contact Control Techniques for other cables e.g. Resolver and SinCos Absolute feedback.

230V Unimotor EZ Cable Selection

Unidrive SP Model	Motor Model	Motor Power Cable (yyy=length in metres)	Motor Power/Brake Cable (required w/all brake motors) (yyy=length in metres)	Feedback Cable ① (yyy=length in metres)
SP1201	75EZB300CACAA	PSBGFA-yyy		SIBAAA-yyy
	75EZB301CACAA		PBBGFA-yyy	
SP1203	75EZD300CACAA	PSBGFA-yyy		SIBAAA-yyy
	75EZD301CACAA		PBBGFA-yyy	
SP1204	95EZB300CACAA	PSBGFA-yyy		SIBAAA-yyy
	95EZB301CACAA		PBBGFA-yyy	
SP2201	115EZB300CACAA	PSBGFA-yyy		SIBAAA-yyy
	115EZB301CACAA		PBBGFA-yyy	
SP2202	95EZD300CACAA	PSBGFA-yyy		SIBAAA-yyy
	95EZD301CACAA		PBBGFA-yyy	
SP2203	142EZB300CACAA	PSBGFA-yyy		SIBAAA-yyy
	142EZB301CACAA		PBBGFA-yyy	
SP2203	115EZD300CACAA	PSBGFA-yyy		SIBAAA-yyy
	115EZD301CACAA		PBBGFA-yyy	
SP3201	115EZE300CACAA	PSBAGA-yyy		SIBAAA-yyy
	115EZE301CACAA		PBBAGB-yyy	
SP3202	142EZD300CACAA	PSBBGA-yyy		SIBAAA-yyy
	142EZD301CACAA		PBBBGA-yyy	
SP3202	190EZA300CACAA	PSBBGA-yyy		SIBAAA-yyy
	190EZA301CACAA		PBBBGB-yyy	

① Cable for incremental encoder shown. Contact Control Techniques for other cables e.g. Resolver and SinCos Absolute feedback.

Epsilon

OVERVIEW

The Epsilon Series is the most compact digital servo drive in the Control Techniques range. Designed to fit in 152mm deep cabinets, with cables attached. Epsilon drives still possess the functionality and flexibility found in our other drives and servos.

There are three sizes of each Epsilon drive: 2 Amp, 3 Amp and 5 Amp, with the largest drive delivering up to 6Nm continuous torque. Each drive contains a 14-segment status display, reset button, removable connectors and utilises standard "D" type connectors.



- **90 to 264 VAC 1Ø input power**
- **Up to 6Nm continuous torque**
- **Drive options: (in 2,3 or 5 Amp)**
 - Base Unit Eb
 - Indexing Ei
 - Indexing with DeviceNet Ei-DN
- **Easy install, setup and operation**
 - Compact, space saving design, 152mm panel depth including cables
 - Pluggable connectors, standard D-type and screw terminals
 - State-Space Observer Control, which allows 10-1 inertia mismatch out of the box, and 50-1 with tuning
 - Free PowerTools Software, and upgrades
- **Programmable, optically isolated I/O**
- **RS232/485 serial communication interface using Modbus protocol**
- **14-segment status and diagnostic display, time-stamping of last 10 faults for easy troubleshooting**
- **Field programmable flash memory firmware (upgrades are free)**
- **24VDC auxiliary input for logic backup**

The Epsilon is available as a base drive, the Epsilon Eb; or as a single-axis positioning, indexing drive, the Epsilon Ei. The Epsilon Ei is also available with DeviceNet-Epsilon Ei-DN.

Power Tools FM Software

The Epsilon is very easy to commission and program using PowerTools FM software. This Windows™-based programming environment makes extensive use of drag and drop editing, tabbed setup screens and hierarchical views. On-line help is a mouse click away to answer any questions. Application notes, programming examples and the current version of PowerTools FM software can be downloaded from www.ControlTechniques.com/downloads.html at no charge. PowerTools FM is used to select the operating mode and motor; configure I/O, set velocity limits and torque levels, and monitor drive and I/O Status.



POWERTOOLS FM IS SUPPLIED FREE WITH THE DRIVE OR VISIT
www.controltechniques.com/download.htm



Epsilon Eb

Base Drive Operation

The Epsilon Series Eb Drive is a compact drive ideal for use with single and multi-axis controllers, PLCs and host controllers. The analog torque or velocity modes can be used with classic position controllers using analog outputs and encoder inputs. The pulse mode is ideal for use with low-cost PLC stepper controllers. Epsilon works in a variety of applications where a host controller provides a command signal determining the desired motion profile.

The Eb Drive is configurable for seven flexible modes of operation, and the parameters for each mode can be adjusted to tailor the drive to the specific application using Windows™-based PowerTools FM software.

- **Analog Torque Mode**
- **Analog Velocity Mode**
- **Digital Velocity Preset**
- **Pulse Mode**
 - Pulse/Pulse
 - Pulse/Direction
 - Pulse/Quadrature
- **Summation of Analog Velocity and Digital Velocity**

- **Programmable I/O**
 - 5 optically-isolated inputs
 - 3 optically-isolated outputs
 - 1 analog input ± 10 VDC, 14 bit
 - 2 analog output ± 10 VDC, 10 bit
- **Programmable encoder output, (up to 2,048 lines per revolution)**
- **Separate stop and travel limit decel ramps**
- **Torque, travel, following error and velocity limits**
- **8 user defined speed presets with individual accel/decel rates**
- **2 Programmable torque level outputs**
- **In Motion velocity output**



STANDARD CONTROL MODES

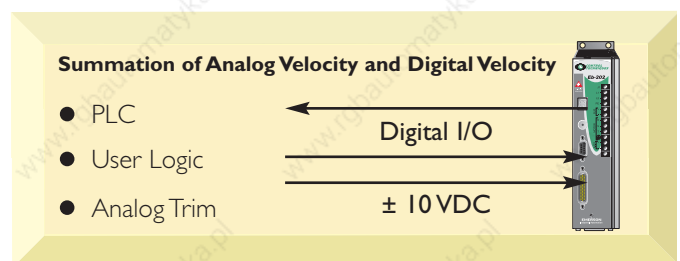
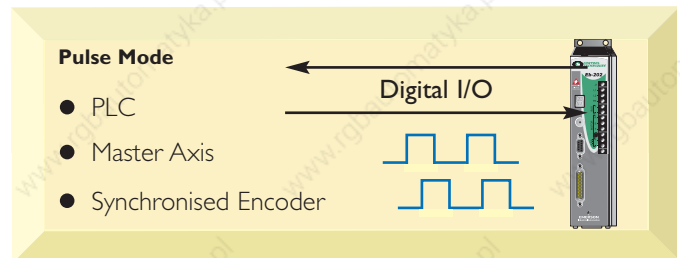
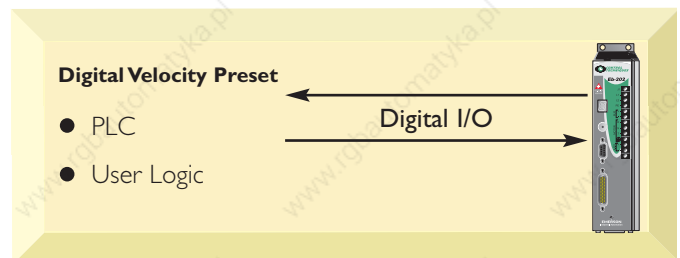
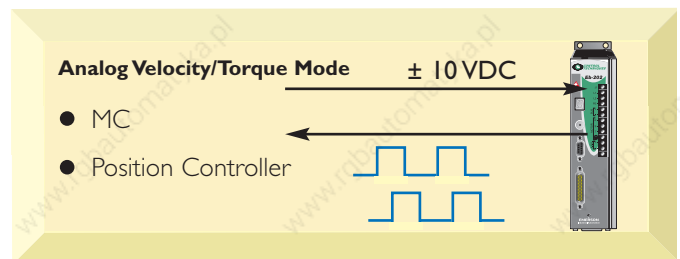

The operating mode of the drive is simply selected with one click in the PowerTools FM detailed setup tab.

Pulse Mode

In Pulse Mode the drive will receive pulses from a master source (single-ended or differential), which can be interpreted in three ways:

- Pulse/Pulse
- Pulse/Direction
- Pulse/Quadrature

Application Examples

- PLC pulse command outputs
- Electronic gearing
- Stepper drive replacement
- Web line ratio control

Velocity Mode

Analog – In Analog Velocity Mode the drive develops a velocity command in proportion to the voltage (± 10 VDC) received on the Analog Input. Note: Analog full scale voltage and offset are programmable.

Preset Velocity – In this mode one of up to eight digital velocities can be selected using the digital I/O or Modbus. Each preset has its own accel/decel ramps.

Application Examples

- Clutch-brake replacement
- Phase control with a differential
- Automatic feed control for machining operations
- Spindle speed control

Velocity Summation – This mode combines the features of Analog Velocity and Preset Velocity in one mode. It allows running a preset velocity and trimming it with an analog input, or vice versa, allowing advanced applications to be solved simply and elegantly without complex controllers.

Application Examples

- Loop/dancer arm control
- Phase advance/retard
- Speed trimming

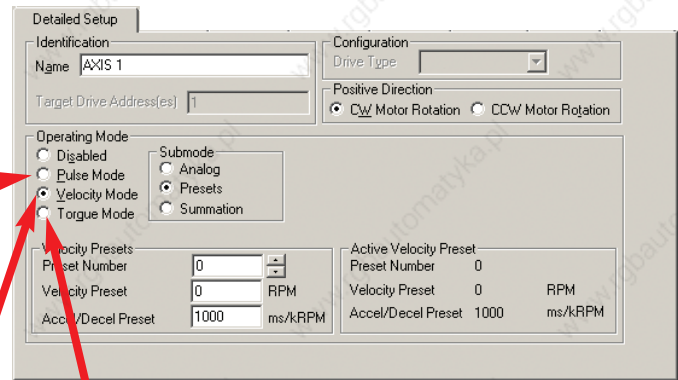

Torque Mode

In Analog Torque Mode the drive develops a torque command in proportion to the the voltage (± 10 VDC) received in the Analog Input. Note: Analog full scale voltage and offset are programmable.

Application Examples

- With Position/Velocity Controller
- Tension Control

Flexible I/O Functionality

The digital I/O of the drive is completely programmable with the ability to map one or more I/O functions to the I/O points.

Input Functions

Stop
Reset
Travel Limit (+)
Travel Limit (-)
Torque Limit Enable
Torque Mode Enable
Velocity Presets
Brake Release
Brake Control

Output Functions

Drive OK
At Velocity
Travel Limits (+)
Travel Limits (-)
In Motion (+)
In Motion (-)
Power Stage Enabled
Torque Limit Active
Velocity Limiting Active
Fault
Brake
Shunt Active
Torque Level 1 & 2 Active
Foldback Active

Epsilon Ei

Indexing Drive

The Epsilon Ei offers user units, indexing, homing and jogging, and additional I/O in a package that is the same compact size as the base Eb. Operating information is setup via a PC. These setup parameters are easily entered and stored with the use of our Windows™-based PowerTools-FM software. The setup can be downloaded, stored on disk or printed out for documentation.

User Units

Using PowerTools FM, the Ei is easily programmed. Homing, Jogs and Indexes are set up using engineering units. This allows for an easy translation of motor revolutions to rotary, linear or other units.

- **Programmable I/O**

- 12 optically-isolated inputs
- 7 optically-isolated outputs

- **16 indexes**

- Chaining index capability
- Chain indexes to home

- **Jogging and Homing**

- 2 jog velocities
- Homing
- Home to sensor
- Home to marker
- Home to sensor then marker

- **User Units**

- Distance
- Velocity
- Time Scale
- Acceleration



INDEXING

The Epsilon Ei drive is easily programmed to meet a wide variety of indexing requirements, either using our PowerTools FM software or with a Modbus Master. Sequencing multiple indexes is possible using the chaining command.

- 16 indexes – Incremental, Absolute, Registration, Rotary Plus, and Rotary Minus index types
- Parameters for Distance, Velocity, Accel/Decel, Dwell and Registration to Sensor or Torque Levels
- Chaining Options – Counts, Repeat Counts, Repeat Forever, Stop, Start Next Index, Wait for Run Next Input Function

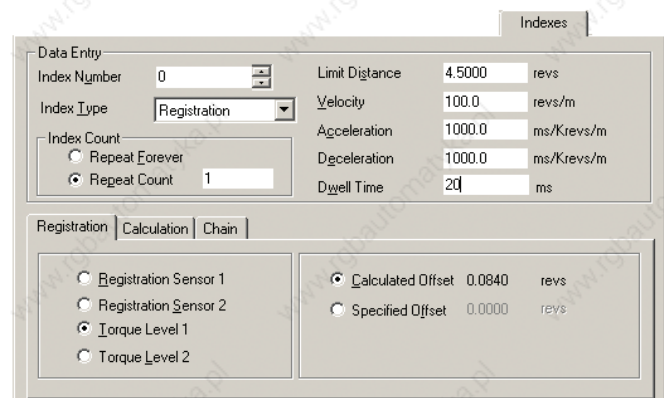

The screenshot shows the 'Indexes' configuration window in the PowerTools-FM software. It is divided into 'Data Entry' and 'Registration' sections.

Data Entry:

- Index Number: 0
- Index Type: Registration
- Index Count:
 - Repeat Forever
 - Repeat Count: 1
- Limit Distance: 4.5000 revs
- Velocity: 100.0 revs/m
- Acceleration: 1000.0 ms/Krevs/m
- Deceleration: 1000.0 ms/Krevs/m
- Dwell Time: 20 ms

Registration:

- Registration Sensor 1
- Registration Sensor 2
- Torque Level 1
- Torque Level 2
- Calculated Offset: 0.0840 revs
- Specified Offset: 0.0000 revs

JOGGING

The jogging function is comprised of two velocities with separate accel/decel ramps programmed in user units.

- Inputs: Jog +, Jog -, Jog Fast
- Parameters for Jog Velocity, Jog Fast Velocity, Accel and Decel

Setup	User Units	Inputs	Outputs	Jog	Home	Indexes	Tuning
Jog Velocity	100.0			revs/m			
Jog Fast Velocity	200.0			revs/m			
Acceleration	1000.0			ms/Krevs/m			
Deceleration	1000.0			ms/Krevs/m			
Max Motor Speed	5000.0000			revs/m			

HOMING

The Homing feature set in the Ei is extensive. The parameters available give the user added flexibility and simplify setting homing functions.

- Home to Sensor, Marker, Sensor & Marker
- If on Home sensor; then back off before homing, go forward to next sensor
- Home Offset distance relative to sensor/marker
- Parameters for Velocity, Accel, Decel, Home Offset, End-of-Home Position and Limit Distance
- Chain to Index Number

Home	
Home Reference	Velocity: 100.0 revs/m
<input type="radio"/> Sensor <input type="radio"/> Marker <input checked="" type="radio"/> Sensor and Marker	Acceleration: 1000.0 ms/Krevs/m
	Deceleration: 1000.0 ms/Krevs/m
	Max Motor Speed: 5000.0000 revs/m
Chaining	Home Offset
<input type="checkbox"/> Chain To Index 0	<input type="radio"/> Calculated Offset 0.0840 revs <input checked="" type="radio"/> Specified Offset 0.0000 revs
	End of Home Position: 0.0000 revs
	<input type="checkbox"/> Limit Distance: 0.0000 revs
	If on sensor...
	<input checked="" type="radio"/> Back off before homing <input type="radio"/> Go forward to next sensor

FLEXIBLE I/O FUNCTIONALITY

The digital I/O of the drive is completely programmable with the ability to map one or more I/O functions to the I/O points.

Input Functions

Index Initiate
 Index Select 0
 Index Select 1
 Index Select 2
 Index Select 3
 Run Next Index
 Home Initiate
 Home Sensor
 Define Home
 Stop
 Jog +
 Jog -
 Jog Fast
 Travel Limit +
 Travel Limit -
 Brake Control
 Brake Release
 Reset
 Registration Sensor 1
 Registration Sensor 2
 Torque Limit Enable

Output Functions

Absolute Position Valid
 End of Index
 End of Index Motion
 End of Index Count
 End of Chaining Counts
 Registration Limit Distance Hit
 Home Limit Distance Hit
 End of Home
 At Velocity
 In + Motion
 In - Motion
 Drive OK
 Fault
 Brake
 Travel Limit +
 Travel Limit -
 Foldback Active
 Shunt Active
 Torque Limit Active
 Power Stage Enabled
 Torque Level 1 Active
 Torque Level 2 Active
 Index In Position

Epsilon Ei-DN

Indexing with DeviceNet

Small size and large functionality makes the Epsilon Ei-DN a natural fit in any DeviceNet related motion application. The Ei-DN retains the same footprint as the Ei and now uses Polled I/O and Explicit Messages to change or initiate any user parameter in the drive via DeviceNet. Choose between any one of four pre-defined DeviceNet word setups.

- **Index Select Pre-defined**
(Static DeviceNet Word Block, full Ei features)
- **Index Select User-defined**
(Dynamic DeviceNet Word Block, full Ei features)
- **Index Type**
(Position Control with Ei functionality)
- **Position Control**
(Position Control only)

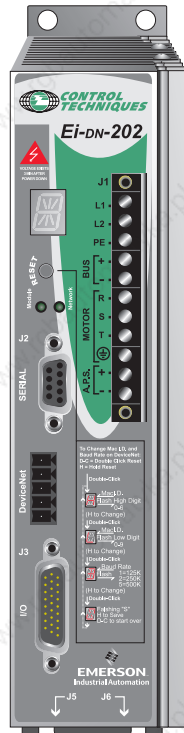

- **Supports Explicit Messaging**
- **Polled (8 bytes in, 8 bytes out)***
- **Access to all Motion Parameters within Polled I/O**
- **Up to 63 devices per network**
- **Baud Rate (125k, 250k, 500k) and MaclD configurable via PowerTools FM or the "one-touch" reset button**
- **Module and Status LED's located on the front of the drive**
- **25 milliamp DeviceNet draw**
- **Easy 5-wire terminal block for DeviceNet connection**

*In and Out refers to PLC Inputs and Outputs

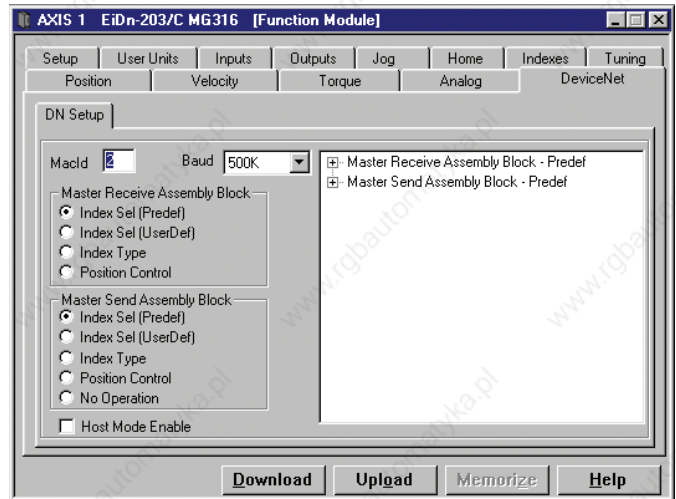

Change the nature of the pre-configured assembly blocks by simply changing the mapping of the DN bits. The DN Bits are user defined bits that can have different I/O functions mapped to them.

When online, with PowerTools FM, the online DeviceNet tab gives the user a view of the actual data that is being sent and received through the DeviceNet network. Watch functions turn on and off over DeviceNet in PowerTools FM. Look at transmit and receive message counters, check the established connections, even look at the current baud rate, MaclD and Master MaclD.

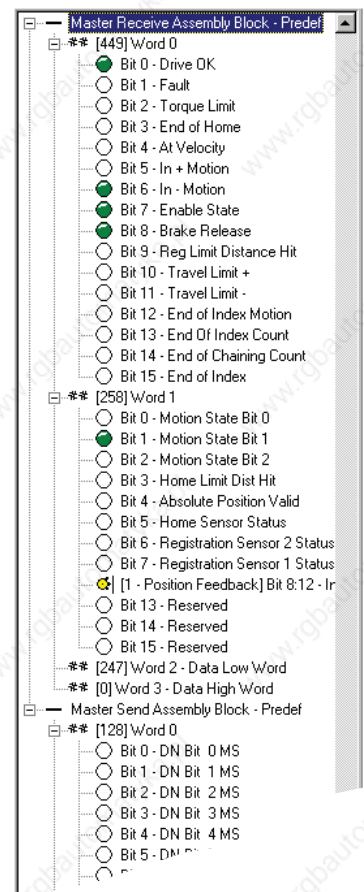

TERMINAL DIAGRAM & DESCRIPTION

Serial (J4)	
Pin Number	Signal
3	RS-232 TX
2	RS-232 RX
6	Serial +5VDC
5	Serial 0V Common
4	RS-485+
9	RS-485-
1	Shield
7,8	No Connect

DeviceNet (Ei-DN Only)	
Pin Number	Signal
1	V-
2	CAN_L
3	Drain
4	CAN_H
5	V+

Command (J5)	
Pin Number	Signal
15	Analog Command In +
14	Analog Command In -
8	Encoder Out A
9	Encoder Out A/
23	Encoder Out B
24	Encoder Out B/
37	Encoder Out Z
38	Encoder Out Z/
27	Pulse In A
41	Pulse In A/
26	Pulse In B
40	Pulse In B/
25	Pulse In Z
39	Pulse In Z/
20	Pulse In A (single ended)
36	Pulse In B (single ended)
16	I/O Input Drive Enable
1	I/O Input 1
2	I/O Input 2
3	I/O Input 3
4	I/O Input 4
19	I/O Output 1
18	I/O Output 2
17	I/O Output 3
33	I/O Supply +
34	I/O Supply +
31	I/O Supply 0V
32	I/O Supply 0V
29	Analog Out 0V
43	Analog Out Channel 1 +
44	Analog Out Channel 2 +
11	External Encoder +5VDC Power
12	External Encoder Common
28	+15V Power Out (10 mA)
6	RS-485 +
21	RS-485 -
5, 7, 10, 13, 22, 35, 30, 42	No Connect

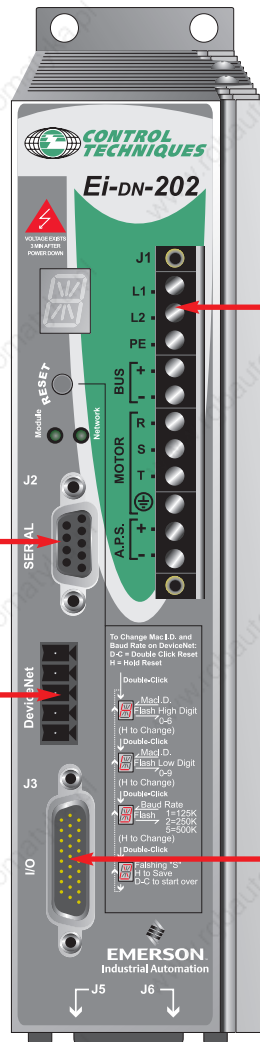

Power (J1)	
Pin Number	Signal
L1	AC Input L1
L2	AC Input L2
PE	PE
Bus +	DC Bus +
Bus -	DC Bus -
Motor R	Motor Power R
Motor S	Motor Power S
Motor T	Motor Power T
	Motor Power Earth
A.P.S. +	Logic Supply Backup +24VDC
A.P.S. -	Logic Supply Backup 0V Common

Digital I/O (J3)	
Pin Number	Signal
1	Input 1
11	Input 2
2	Input 3
12	Input 4
3	Input 5*
13	Input 6*
4	Input 7*
14	Input 8*
5	Input 9*
15	Input 10*
6	Input 11*
16	Input 12*
10	Drive Enable
19	I/O Supply +
20	I/O Supply 0V
7	Output 1
17	Output 2
8	Output 3
18	Output 4*
9	Output 5*
25	Output 6*
26	Output 7*
21-24	No Connect

*Indexing Versions Only

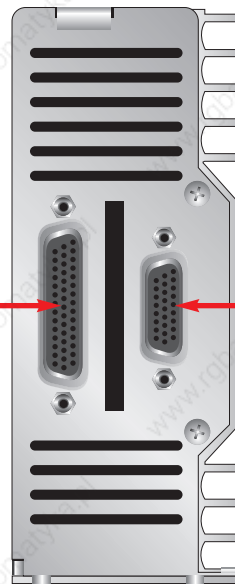

Feedback (J7)	
Pin Number	Signal
1	Motor Encoder A
10	Motor Encoder A/
2	Motor Encoder B
11	Motor Encoder B/
3	Motor Encoder Z
12	Motor Encoder Z/
4	Motor Commutation U
13	Motor Commutation U/
5	Motor Commutation V
14	Motor Commutation V/
6	Motor Commutation W
15	Motor Commutation W/
7,8	Encoder +5VDC Supply
17	Encoder 0V Common
9	Motor OverTemp
16,18-26	No Connect

DIMENSIONS (mm)

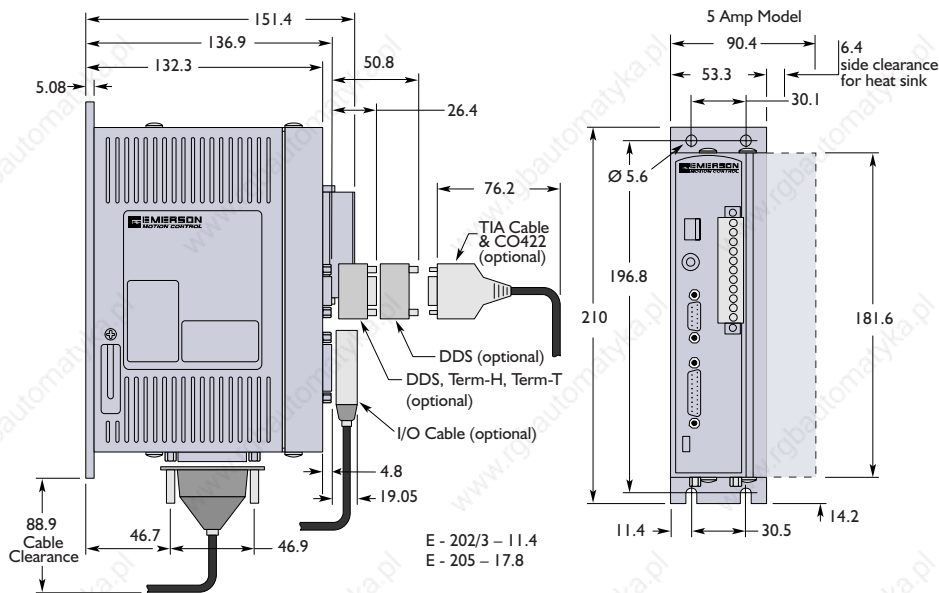

RATINGS

EPSILON	Output rms A	Output Peak (A) 4s
202	1.8	3.6
203	3	6
205	5	10

SPECIFICATION

Power Requirements

AC Input Voltage	1Ø, 90 to 264 VAC, 47 - 63 Hz (240 VAC for rated performance)
Switching Frequency	20 kHz
Logic Supply	Internal
Auxiliary Logic Supply	+18 to 30 VDC @ 0.5A
Encoder Supply Output	+5 VDC, 250 mA
System Efficiency	93%
Cooling Method	Epsilon 202-205: Convection

Regeneration

Internal Energy Absorption (115V)	Epsilon 202/3: 41 Joules Epsilon 205: 113 Joules
Internal Energy Absorption (230V)	Epsilon 202/3: 18 Joules Epsilon 205: 48 Joules
External:	Connection to RSR-2 with external resistor; 20 Ohm min, 15 Arms, 2kW

Drive Control Inputs

Analog:	+/-10VDC, 14 bit, 100kOhm, Differential Analog Max. Input Rating: Differential +/-14 VDC, Each Input with Reference to Analog Ground +/-14VDC
Digital:	+10 to 30 VDC, 2.8kOhm, Sourcing, Optically Isolated
Pulse:	Differential Rs-422, 2MHz/Channel, 50% Duty Cycle
Single Ended:	TTL Schmitt Trigger 1MHz/Channel, 50% Duty Cycle
Motor Overtemperature:	0 to +5VDC, 10kOhm, single ended

Drive Control Outputs

Analog:	+/-10VDC, 10 bit, Single-ended 20mA
Digital:	+10 to 30VDC, 150mA, Optically Isolated
Sourcing	
Pulse:	Differential RS-422 and TTL compatible, 20mA/Channel Sink or Source
I/O Supply:	+10 to 30 VDC

I/O Supply:

Environmental

Rated Ambient Temperature:	0° to 40°C for rated performance
Maximum Ambient Temperature:	0° to 50°C with power derating of 3.5%/ 1°C above 40°C
Rated Altitude:	1000m
Maximum Altitude:	For altitudes > 1000m derate output by 1%/ 100m
Vibration:	10 to 2000 Hz @ 2g
Humidity:	10 to 95% non-condensing
Storage Temperature:	-25° to 75°C
Ingress Protection:	IP20

Serial Interface

RS232/RS485 Modbus RTU w/ 32-bit extension - 9600 to 19.2 kBaud
Internal RS232 to RS485 Converter

Drive Weight

Epsilon 202/3 1.5 kg
Epsilon 205 1.7 kg

DeviceNet (Optional)

Power Consumption:	25mA
Baud Rates:	125, 250 and 500kpsNode
Addresses:	00-63 Messaging: Explicit and Polled I/O

Unimotor EZ

OVERVIEW

The Unimotor EZ range has been developed following extensive research and testing of thermal dynamic theories and practices.

This range is compatible with Epsilon and available in 3 frame sizes 55*; 75; 95; in a unique and instantly recognisable finned design that offers extra strength, rigidity and thermal performance. These are important features for high performance servo systems.

PERFORMANCE MATCHED MOTORS

EZ Series Brushless AC Servo Motors

The EZ series delivers excellent motor speed control and highly accurate positioning capability demanded by automated machinery industries.

The EZ series of motors provide high torque with minimal cogging torque. Incremental encoder feedback and commutation results in excellent speed and position control. The use of specially developed coil wire gives ultimate reliability and quality. All these design criteria combined with high energy magnets mean EZ motor's performance is truly dynamic.

SPECIFICATION

Standard motors have UL and CAN/CSA recognised Insulation System to class. The CTD/IS/2000/01 insulation system number on the motor number plate, together with the symbol, denotes this. Earlier motors may display this information on a separate label on the rear cover.

If the UL symbol has "E215243" underneath, then this indicates full motor recognition.

Machinery Directive 89/392/EEC amended to 98/37/EC

Low Voltage Directive 73/23/EEC

- EN 60034 General requirements for rotating electrical machinery
- EN 60034-1 Duty: S1 Continuous
Storage: -15° to 40° Operating: Min ambient 0°C; max ambient 40°C
Less than 1000m altitude
Relative humidity: 90% Non condensing
- EN 60034-5 Degree of Ingress protection: IP65S (with mating connector & cable fitted)
- EN 60034-6 Method of cooling: free circulation, free convection
- EN 60034-7 Flange mounted: horizontally or vertically
- EN 60034-8 Terminal markings: U V W
- EN 60034-11 Thermal protection: PTC thermistor; 165°C TPI 11 (Not SL variants)
- EN 60034-18 Insulation system: Class H 600V, UL number E214439
- EN 60072 Dimensions and output for rotating electrical machines
- EN 60072-1 Type N (Customer variants)
- ISO 1940-1 Balancing: to G6.3, (ISO8821 half key convention)

Equipment is not deemed suitable for use in an explosive atmosphere.

This product has been designed to be operated with Control Techniques drives and must not be put into service unless the machinery into which it is to be incorporated has been declared in conformity with the provisions of the machinery directive.

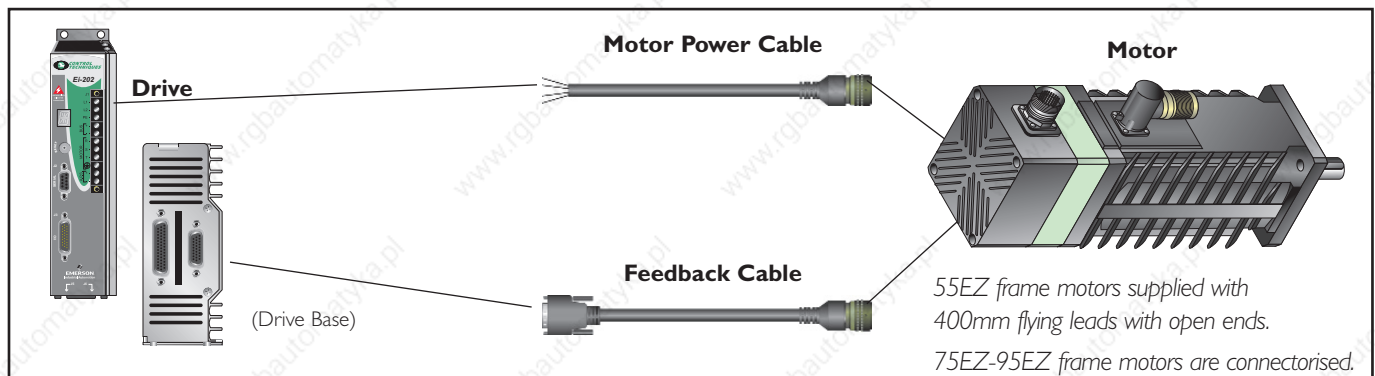

DIMENSIONS (mm) EZ55*

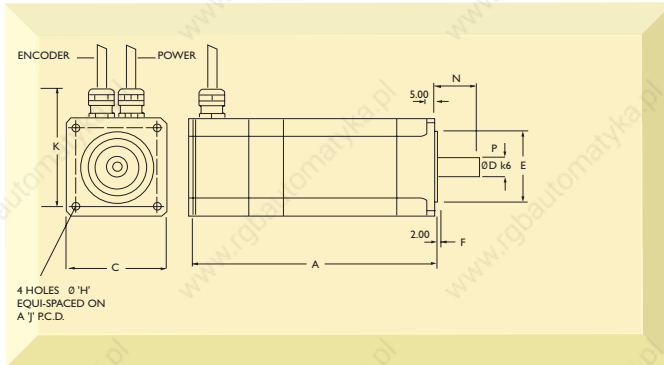

Frame Sizes EZ 75 - 95

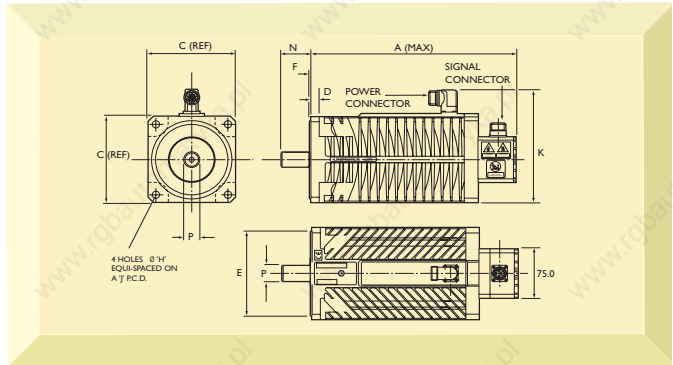

* EZ55 is not of the same finned design as the 75, 95

Ref	Description	55A	55B	55C	75B	75C	75D	95B	95C
A	Length overall (unbraked)	126	159	189	241	271	301	252	282
A	Length overall (braked)	141	171	201	271	301	331	282	312
C	Flange Square	55	55	55	75	75	75	95	95
D	Flange Thickness	5	5	5	7	7	7	9	9
E	Register Diameter	40 (j6)	40 (j6)	40 (j6)	60 (j6)	60 (j6)	60 (j6)	80 (j6)	80 (j6)
F	Register Length	2	2	2	2.4	2.4	2.4	2.9	2.9
H	Fixing Holes Diameter	4.5	4.5	4.5	5.8 (H14)	5.8 (H14)	5.8 (H14)	7 (H14)	7 (H14)
J	Fixing Hole p.c.d	63	63	63	75	75	75	100	100
K	Overall Height	73	73	73	126	126	126	146	146
N	Shaft Length (front)	20	23	23	30	30	30	40	40
P	Shaft Diameter (front)	9	11	11	14	14	14	19	19

RATINGS

Unimotor EZ for 3 phase drives 200 - 240 VAC and Encoder Feedback		Stall torque; stall current; Kt; Ke; rated torque and power relate to maximum continuous operation in a 40°C ambient								
Δt = 100°C, 40°C ambient		All data subject to +/-10% tolerance								
Motor Frame Size (mm)		55			75			95		
All Speeds	Frame Length	A	B	C	B	C	D	A	B	C
Continuous Stall Torque (Nm)		1.2	2.2	3.1	2.2	3.1	3.9	2.3	4.3	5.9
Peak Torque (Nm)		3.6	6.6	9.3	6.6	9.3	11.7	6.9	12.9	17.7
High Inertia (kgcm ²)		1.2	1.6	2.1	1.6	2.1	2.5	3.5	4.5	5.6
Standard Inertia (kgcm ²)		0.6	1.0	1.5	1.0	1.5	1.9	1.4	2.5	3.6
Weight (kg)		3.0	3.7	4.4	3.7	4.4	5.1	5.0	6.1	7.2
Winding Thermal Time Const.(sec)		81	74	94	74	94	100	172	168	183
Maximum Cogging (Nm)		0.02	0.03	0.04	0.03	0.04	0.05	0.03	0.06	0.08
Rated Speed 2000 (rpm) Ke (NOM) = 85.5 V/krpm					Kt (Nm/A) 1.22 Ke (V/krpm) 75					
Rated Torque (Nm)		1.1	2.1	3.0	2.1	3.0	3.8	2.2	4.0	5.5
Continuous Stall Current (A)		1.0	1.8	2.5	1.8	2.5	3.2	1.9	3.5	4.8
Rated Power (kW)		0.23	0.44	0.63	0.44	0.63	0.80	0.46	0.84	1.15
R (ph-ph) (Ohms)		45.8	15.3	8.52	15.3	8.52	5.72	19.4	6.2	3.16
L (ph-ph) (mH)		98.8	43.4	27.9	43.4	27.9	20.2	59.2	25.8	16.0
Rated Speed 3000 (rpm) Ke (NOM) = 57 V/krpm					Kt (Nm/A) 0.82 Ke (V/krpm) 49.9					
Rated Torque (Nm)		1.1	2.0	2.8	2.0	2.8	3.5	2.0	3.9	
Continuous Stall Current (A)		1.5	2.7	3.8	2.7	3.8	4.8	2.8	5.3	
Rated Power (kW)		0.35	0.63	0.88	0.63	0.88	1.10	0.63	1.23	
R (ph-ph) (Ohms)		18.9	6.26	3.50	6.26	3.50	2.38	8.03	2.68	
L (ph-ph) (mH)		42.5	18.4	11.9	18.4	11.9	8.82	25.6	12.0	
Rated Speed 4000 (rpm) Ke (NOM) = 44.0 V/krpm					Kt (Nm/A) 0.63 Ke (V/krpm) 38.5					
Rated Torque (Nm)		1.0	1.7	2.3	1.7	2.3				
Continuous Stall Current (A)		1.9	3.5	4.9	3.5	4.9				
Rated Power (kW)		0.42	0.71	0.96	0.71	0.96				
R (ph-ph) (Ohms)		10.2	3.39	1.92	3.39	1.92				
L (ph-ph) (mH)		24.6	10.8	7.14	10.8	7.14				

† 55 Frame motor is not UL approved

EPSILON AND UNIMOTOR EZ SELECTION

Motor	Epsilon Model	Epsilon Amps	Stall Torque Nm	Peak Torque Nm	Stall Current amps	Rated Speed rpm	Inertia kgcm ²	Weight (no brake) kg
55EZA500	Eb/Ei-202	1.8	0.65	1.9	1.4	5000	0.12	1.1
55EZB500	Eb/Ei-203	3	1.1	2.8	2.3	5000	0.22	1.6
55EZC500	Eb/Ei-203	3	1.4	2.8	3	5000	0.32	2
75EZB400	Eb/Ei-203	3	2.1	4.2	3	4000	1	3.7
75EZC300	Eb/Ei-203	3	2.7	5.5	3	3000	1.5	4.4
55EZB500	Eb/Ei-205	5	1.1	4.4	2.3	5000	0.22	1.6
55EZC500	Eb/Ei-205	5	1.4	4.8	3.0	5000	0.32	2
75EZD400	Eb/Ei-205	5	3.5	7	5	4000	1.9	5.1
95EZB300	Eb/Ei-205	5	4.2	9.3	4.5	3000	2.5	6.1
95EZC300	Eb/Ei-205	5	4.6	9.3	5	3000	3.6	7.2

All performance data has a tolerance of $\pm 10\%$

SPEED TORQUE CHARACTERISTICS

55EZA00 with Epsilon Eb/Ei 202

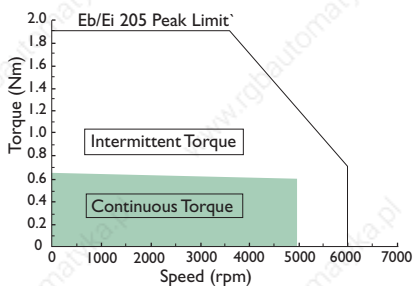

55EZB500 with Epsilon Eb/Ei 203 &

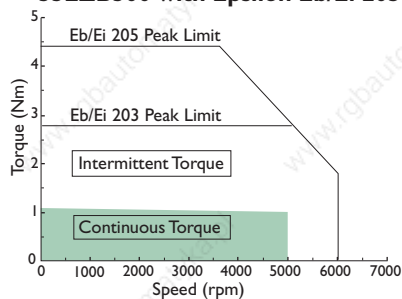

55EZC500 & Epsilon Eb/Ei 203 & Eb/Ei 205

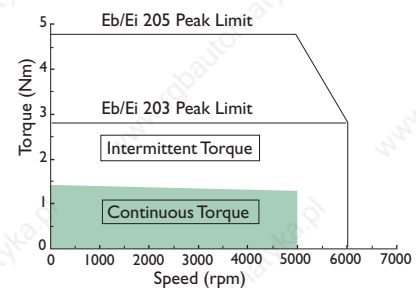

75EZB400 with Epsilon Eb/Ei 203

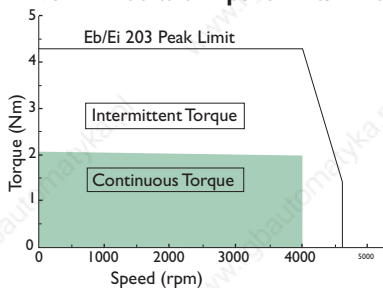

75EZC500 with Epsilon Eb/Ei 203

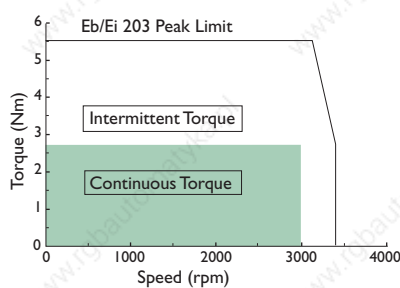

75EZD400 with Epsilon Eb/Ei 205

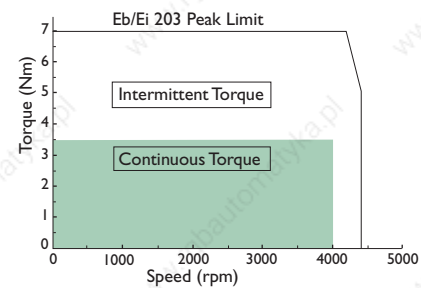

95EZB500 with Epsilon Eb/Ei 205

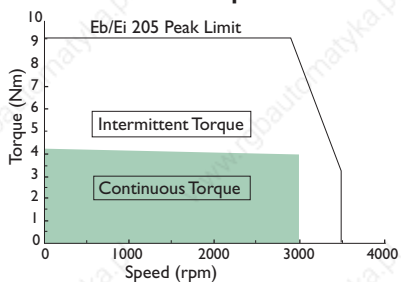

95EZC300 with Epsilon Eb/Ei 205

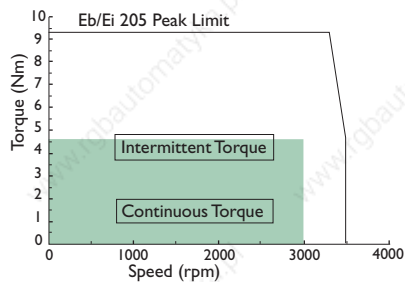

All performance data listed above has a ± 10 tolerance and is subject to change at any time without notice.

Unimotor EZ Power Cable selection

Cable type – PS for motor without brakes, PB for motors with brake.

Jacket – B is for a PUR sheath and is the standard selection. A is for a PVC sheath to be used on the DS brake cable only.

Conductor Size – Select the conductor size according to the motors STALL CURRENT.

Include forced cooling performance if applicable.

Cables of 6mm² and above will be fitted with ring terminals only.

Ratings are for individual cables (not lashed together) in free air temperature up to 40°C - make allowances as appropriate.

Connection detail drive end – Select the correct drive end connection for the drive in use.

Connection detail motor end – Select the correct motor end connection for the motor in use.

Length – Numbers represent the required cable length in metres. Conversion cables will be limited to 0.4m only and the length is not required in the order code.

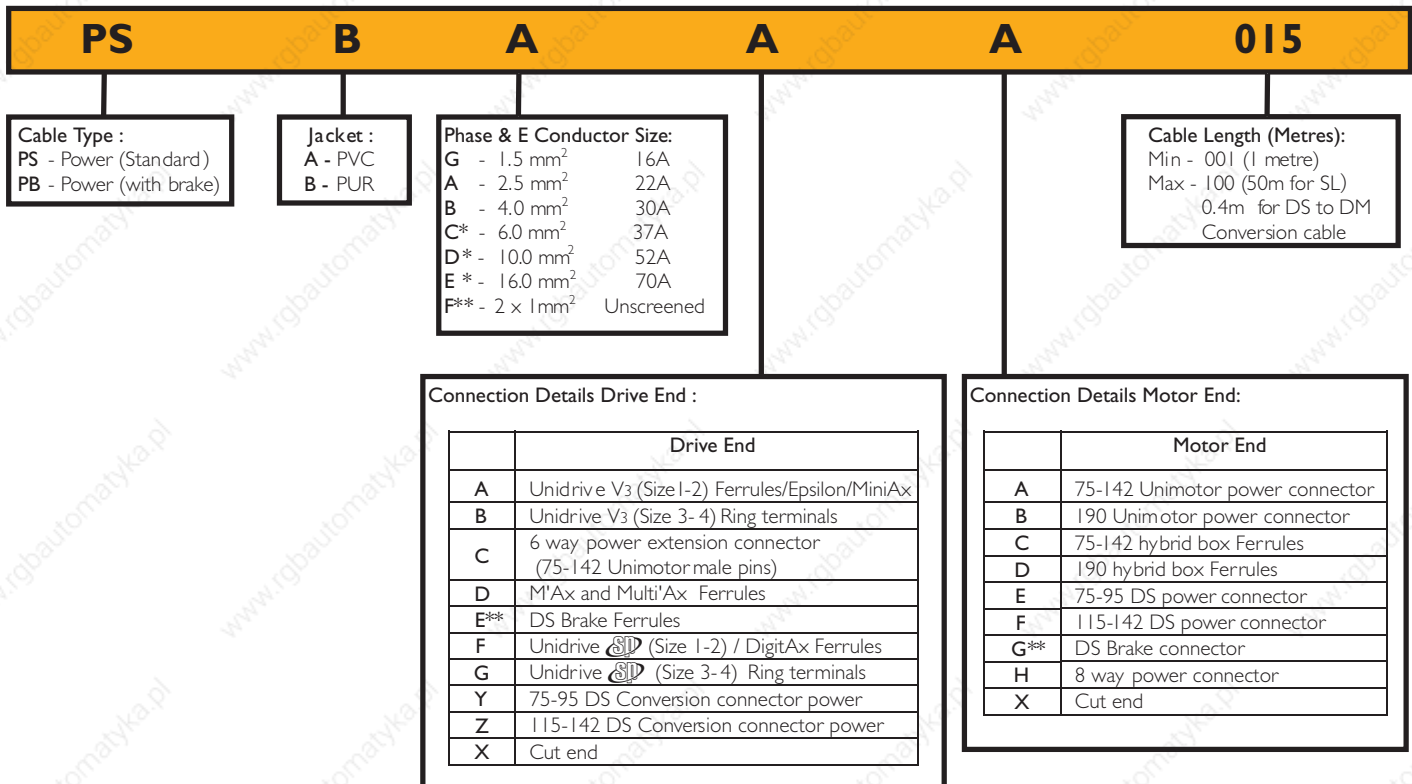

* Ring terminals for Drive studs only
** PVC only available on DS brake cables

Unimotor EZ Signal Cable selection

Cable type – Choose the cable type to match the feedback device.

Jacket – B is for a PUR sheath and is the standard selection.

Special options – A is for standard cable. L is for the low cost 8.5mm incremental cable.

Connection detail drive end – Select the correct drive end connection for the drive in use.

Connection detail motor end – Select the correct motor end connection for the motor feedback device in use.

Length – Numbers represent the required cable length in metres. Conversion cables will be limited to 0.4m only and the length is not required in the order code.

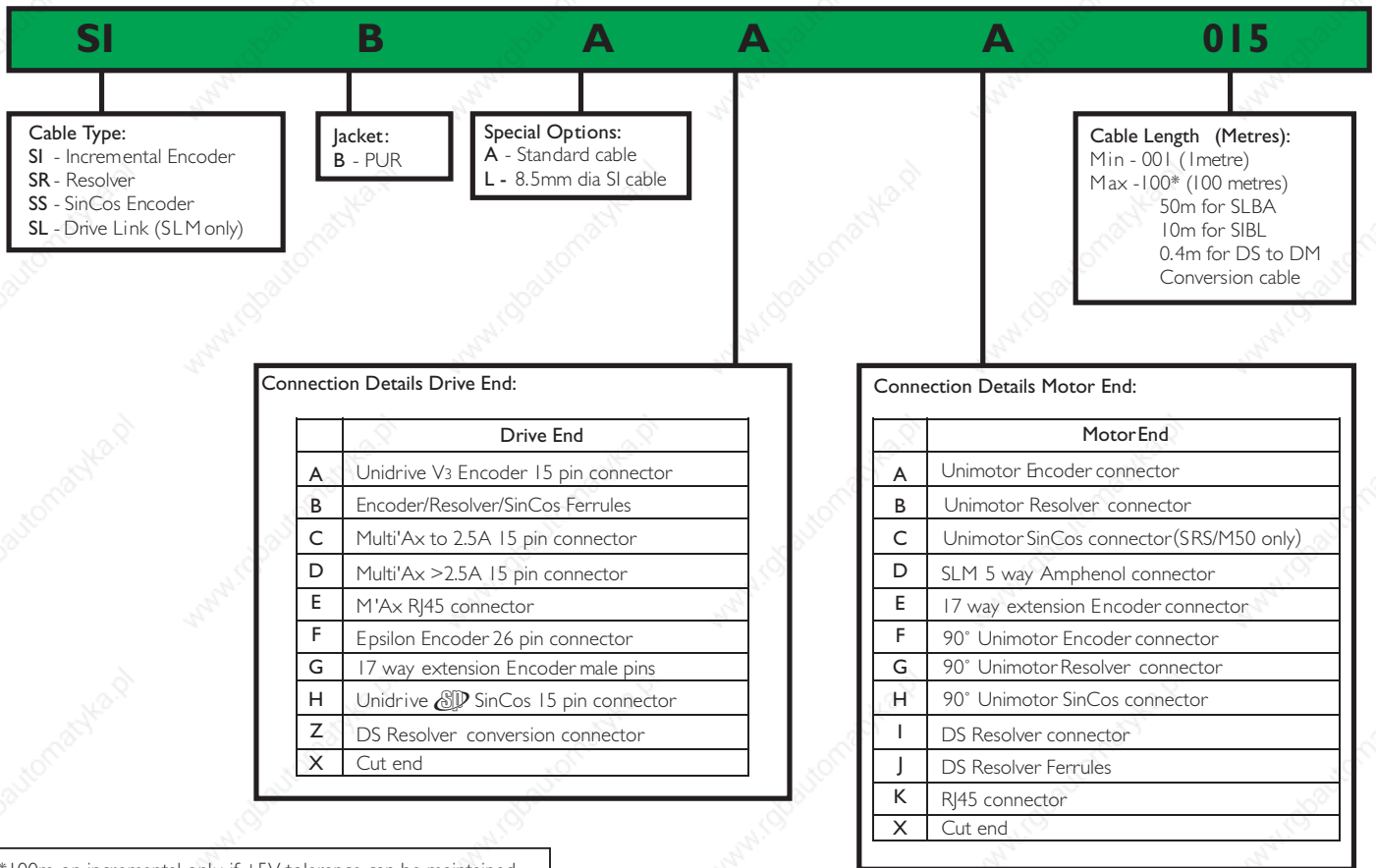

M'Ax and Unimotor

AC Servo drive 1Nm to 20Nm

OVERVIEW

Historically, advances in servo technology have been incremental steps rather than giant leaps. The M'Ax with technology has changed all that. M'Ax redefines totally what a user can - and should - expect from a servo system, in terms of installation costs, set-up times, axis performance and dependability. By achieving substantial improvements in all of these crucial areas, M'Ax provides the machine builder with a simple, powerful and cost effective way of improving the competitiveness and performance of any machine.....

It's an edge that will make all the difference to your machines in ultra competitive global markets.



FEATURE PERFORMANCE

... | Easy Start Up with automatic motor mapping

Easy Start

M'Ax's Automatic Motor Mapping sets itself and gets you going in minutes... No longer do you need to worry about determining and programming the motor type, current, phase angle, inertia, Kt, Ke etc. It is automatic, immediately at power up, even without the need for a PC, thereby ensuring a trouble free and fast start up - Easy Start!

Tuning Is Easy With M'Ax's Gains Calculator...

One step keypad programming calculates the PID gains and gets you running. Better still, if you know your machinery inertia then simply dial it in and one step recalculates the optimal gains for best running.

With A PC It Is Even Easier With M'AxSoft...

M'AxSoft is a windows based drive set-up program that is designed to enable the complete control and display of all parameters within M'Ax.

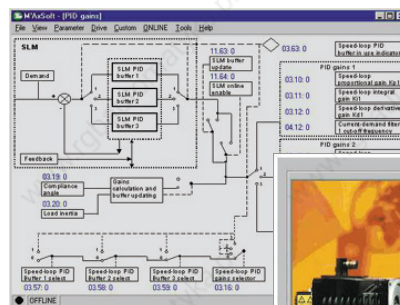

M'AX SERVO CONTROLLER

- Digital clarity with (2.5Mbaud, 4 wire system)
- High resolution feedback 8.3M counts per revolution)
- Lower cabling requirements - 4 core cable
- Advanced SinCos encoders as standard
- Motion controller compatible
- Servo specification
 - Compact design
 - 380 to 480V+/-10%
 - From 3.5 to 12.5A, 200% overload
 - Only 62mm wide
 - Easy start - automatic motor mapping
 - Internal braking resistor
 - DC Bus running
 - Reduced DC Bus running
 - 12 digital I/O
 - Back up supply
 - Gains calculator
 - CE and UL listed
- Also operates in 'Stand alone' mode
 - 16 bit high precision +/-10V input
 - F&D, CW/CCW and Quadrature input
 - 2 analog outputs
 - Simulated encoder output (200-16384ppr)
 - Communications port



...2 Total System Costs Reduced!

- Reducing wiring in the feedback loop - 4 wire system offers significant advantage over the conventional encoder requiring 14 wires
- Reducing cubicle size - M'Ax is compact, only 63mm wide, the minimum of machinery space required for multi axes installation
- Reducing AC supply connections as M'Ax can be DC supply fed in parallel connection
- Reducing cabling as motor thermistors are no longer required - M'Ax offers intelligent thermal modelling for accurate and reliable protection of the motor

Conventional Servo Wiring = 32 Connections

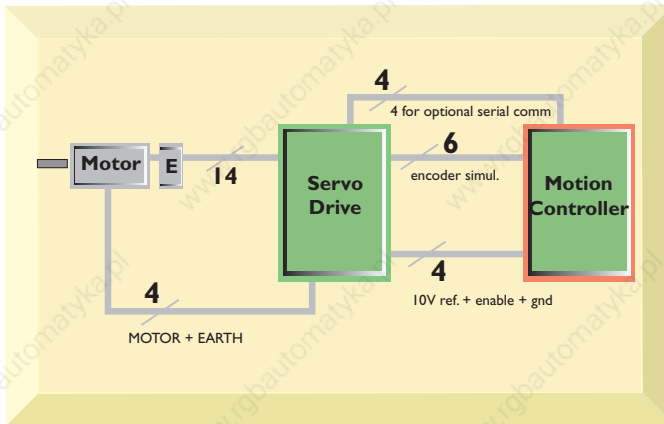

M'Ax Servo Wiring = 12 Connections

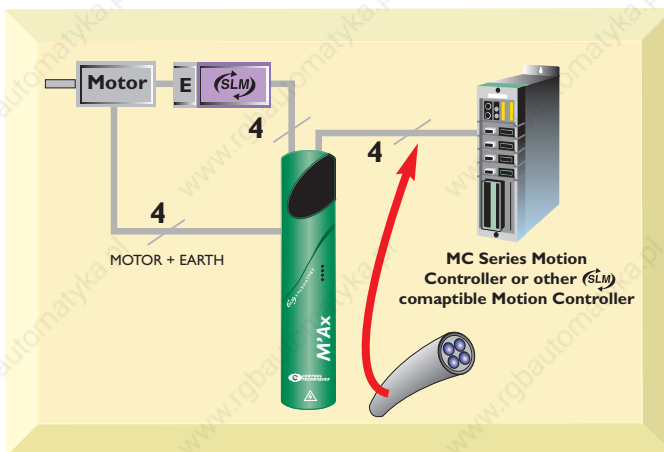

...3 Highest Resolution Feedback

"Perfect" feedback at an affordable price level!

- Advanced SinCos encoders are standard and with **(SLM) technology** the sensitive signals are processed at source to produce the highest resolution in digital form
- Digital clarity is maintained by use of high speed serial link (2.5Mbaud, 4 wire system) to interface between the drive and motor - supports cable runs of up to 50 metres with high level of noise immunity.
- M'Ax feedback is "intelligent" and enables vital dataflow between the motor, drive and also host motion controller if required. For example condition monitoring of motor temperature, performance data and many more control parameters.

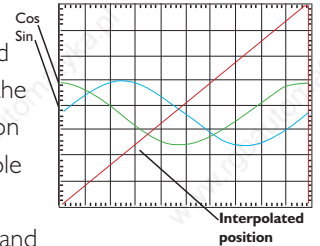

...4 Higher Performance and Precision

Superb precision performance is standard thanks to the revolutionary **(SLM) technology**! M'Ax's feedback provides 8.3 million points per revolution for the speed loop control. With this high resolution we are able to track the smallest deviation and work with gains that do not reach the threshold of instability. The result is high dynamic response with good motion regularity and ultra smoothness in rotation. M'Ax can give your machinery that extra competitive edge through improved machinery performance!

The graphic below shows how **(SLM) technology** makes the difference for a hole cutting machine. In 1 minute - Higher productivity, cuts faster, better accuracy and quality (roundness) is up fourfold.

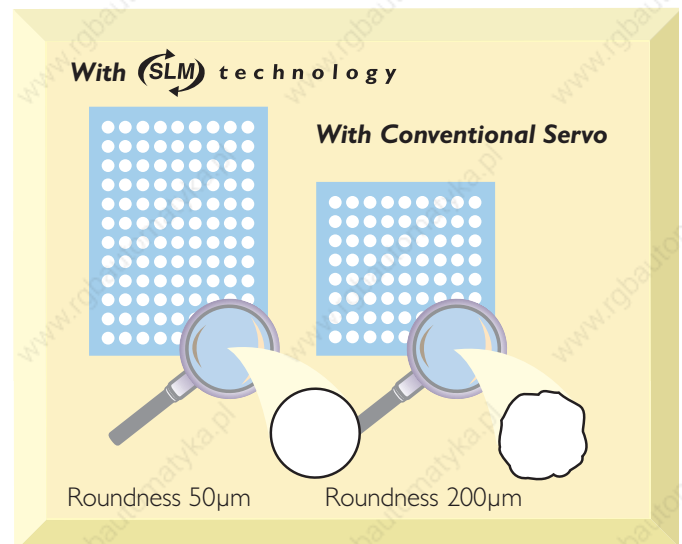

...5 Tomorrow's technology today

(SLM) technology

The **(SLM) technology** uses a combination of Control Techniques 4-wire, ASIC and motor-mounted SinCos encoders to achieve an application invariant 20-fold increase in position feedback resolution (over 8.3 million points per revolution). This is achieved by integrating speed & position control within the feedback system on-board the servomotor. As a result, the **(SLM) technology** is able to overcome the degradation in performance experienced with encoder feedback signals when synchronising multiple servo axes on machines as operating speeds increase.

For the ultimate interpolated multi-axes performance, control loops are deterministic and synchronised to give the lowest jitter in the industry - of 50 nanoseconds. As well as being a performance enhancer now, **(SLM) technology** is also a gateway to the future. Its integration into PC-based motion systems opens up a whole new vista for optimised multi-axis control in the new future.

(SLM) technology – Your Control Benefits

- Perfect trajectory following - high resolution feedback
- Perfect linearity on velocity feed forward
- Perfect dynamic response on acceleration feed forward
- High control loop bandwidth to achieve sub micron precision on position
- Reduced machine vibration - ultra smooth operation

(SLM) TECHNOLOGY

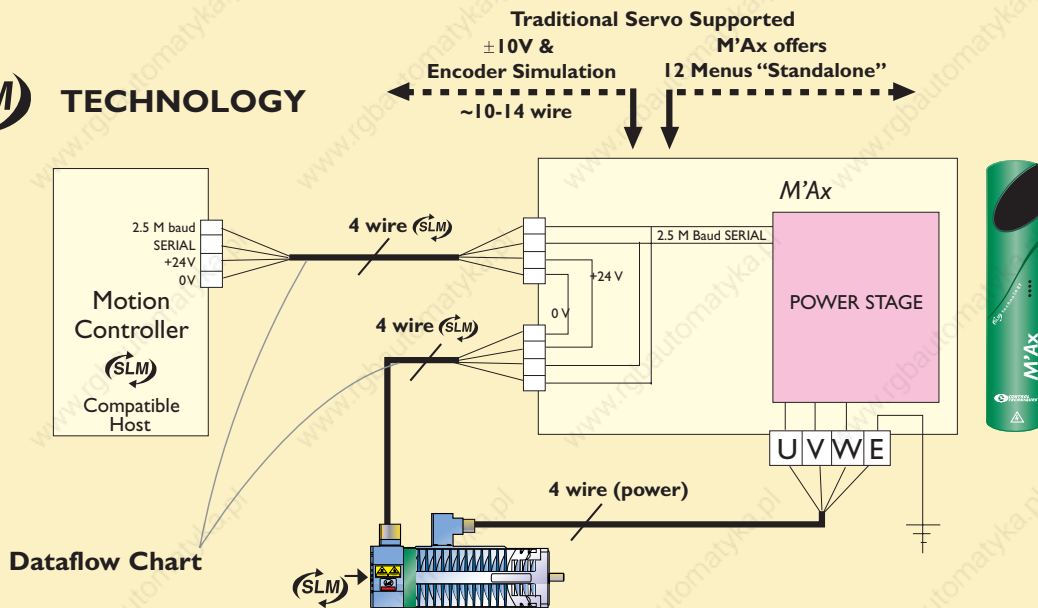

(SLM) Communications Protocol - Fundamental Cycle

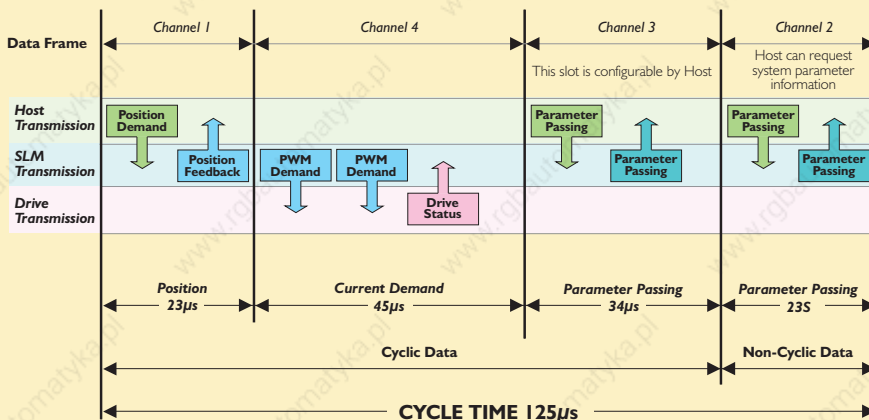

RATINGS

Electrical Data												
	Output Current		External RFI Filter (IP20) Complies with EN50081/1 or 2				Internal Braking Resistor					
	Continuous Amps	Peak Current Amps (2sMax)	Part Number	Max Power Dissipation (w)	L (mm)	W (mm)	D (mm)	Value Ω	Operating Voltage (V)	Peak Current Amps (A)	Peak Power (kW)	Max.Cont Braking Power (W)
M'Ax 403	3.5	7	4200-1645	6	250	45	70	75	780	10.9	8.9	125
M'Ax 406	6.5	13										
M'Ax 409	9.5	19										
M'Ax 412	12.5	25										

Supply Voltage 380 - 480V $\pm 10\%$ (47.5 to 63Hz)
 Rated ambient 45°C (up to 55°C with derating)
 Altitude: derate above 1000m

Relative humidity: 95% non-condensing

TERMINAL DIAGRAM

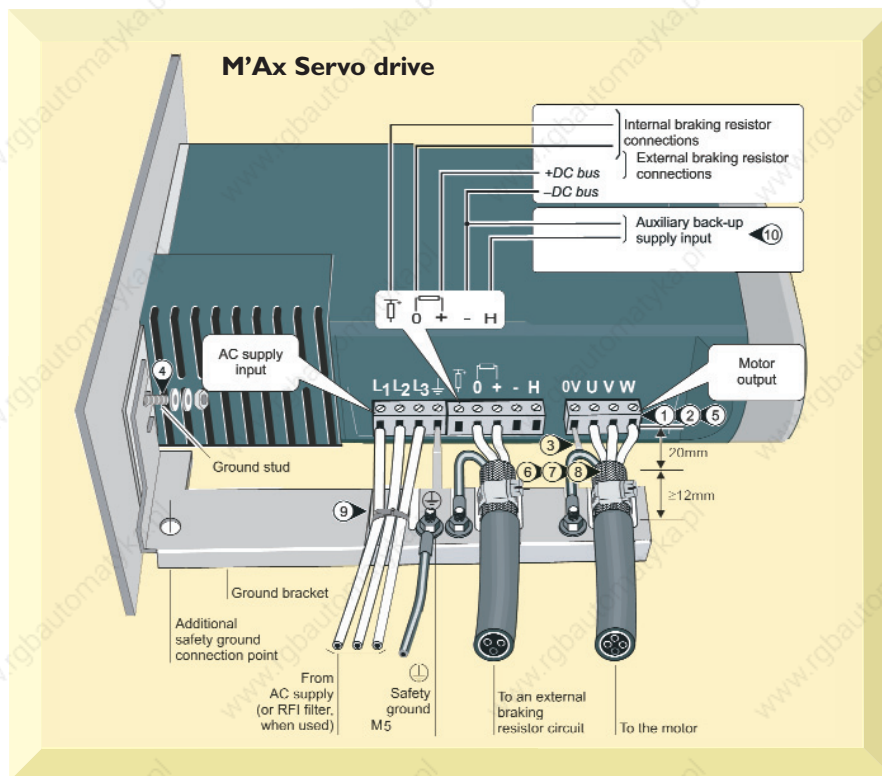

TERMINAL DESCRIPTION

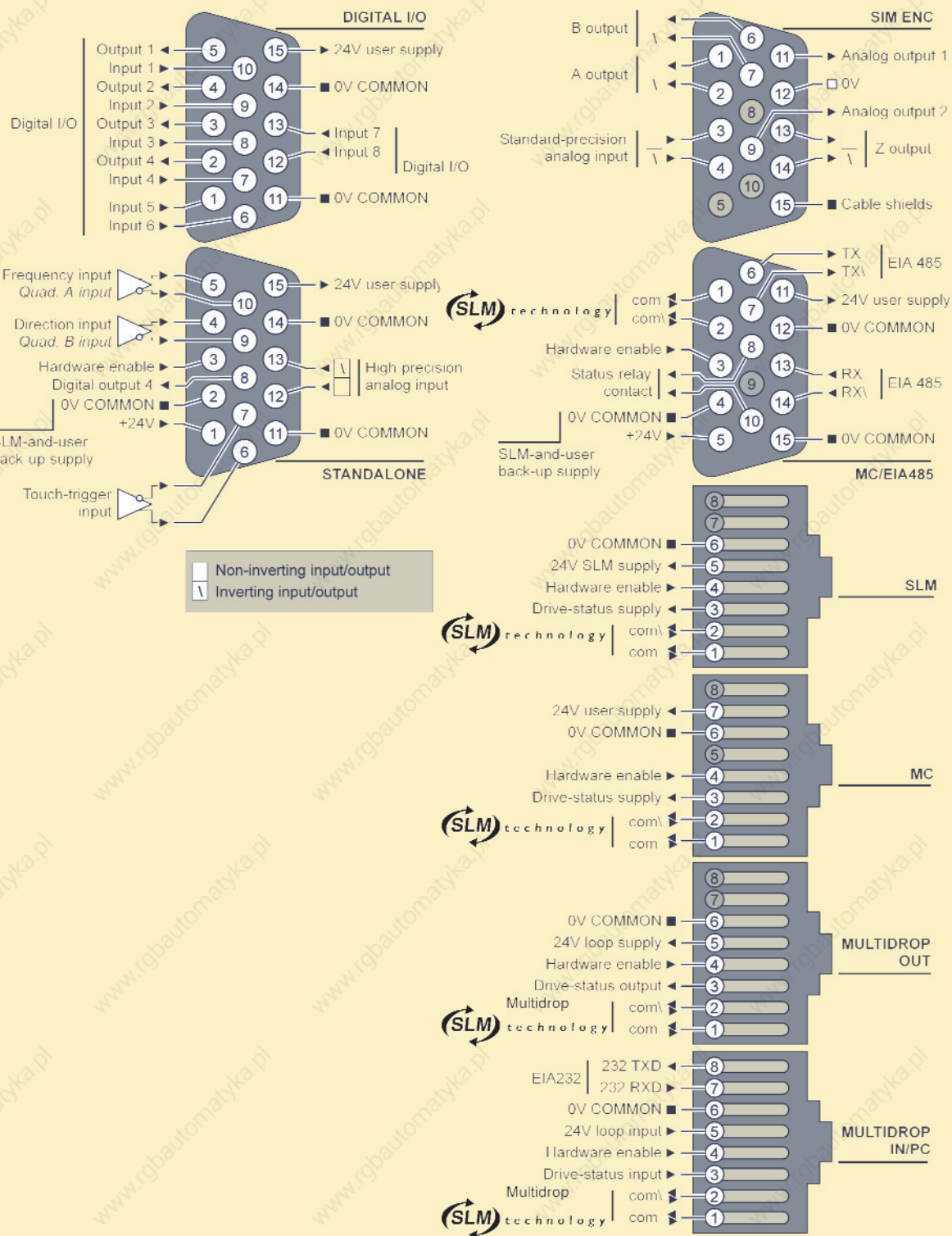

M'AX
Terminal Description

SPECIFICATION



Keypad

- 7 segment removable display
- Memory Pad stores identical set of parameters for easy upload
- 16 bit high precision, $\pm 10V$ differential

Compact Design

- One size for the range 3.5 to 12.5 Amps
- Protection to IP20
- Only 62 mm wide

DC Bus

- Can be supplied from a common DC power supply in parallel with other models
- Reduced DC bus running with drive backup supply

Easy Start

- Automatic motor mapping
- Gains calculator
- MaxSoft with Wizard

'Electronic' Thermistor

- Intelligent thermal modelling
- Accurate monitoring and protection
- Serial data link employed – NO need for thermistor in motor and NO extra cabling requirements

Advanced Feedback

- SinCos encoder as standard
- Reduced cabling 4 wire system – up to 50 metres
- Intelligent capability
- High resolution (8.3 million points per revolution)

Digital I/O

- Opto-isolated
- Eight digital inputs
- Four digital outputs
- 24 V user supply

Back-up Power Supply

- 24 VDC for (SLM) encoder
- 28/32 VDC for drive logic suitable for standby, evacuation system - reduced dc bus running

Standalone

- Frequency & direction or quadrature inputs
- 16 bit High precision $\pm 10V$ differential (if keypad fitted)
- (SLM) and user back up supply
- 24 V user supply

Simulated Encoder

- Encoder quadrature A, B plus Zmarker-pulse outputs (up to 16,384ppr)
- Two analogue outputs
- Standard-precision analogue differential reference input (12 bit)

Communications Port

- RS232 ● RS485 ● ANSI 3.28/Modbus RTU

Braking

- Standard internal resistor 'failsafe' design
- Electronic I²t protection for internal braking resistor
- External resistor connectable

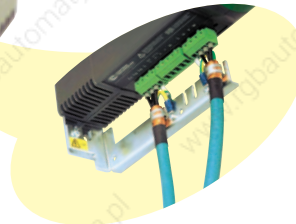

Practical Grounding Bar and Cable Support

- Pluggable terminals for
 - mains supply
 - motor power
 - external braking resistor
- Earthing clamps for motor cable screen

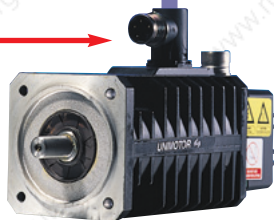

DIMENSIONS (mm)

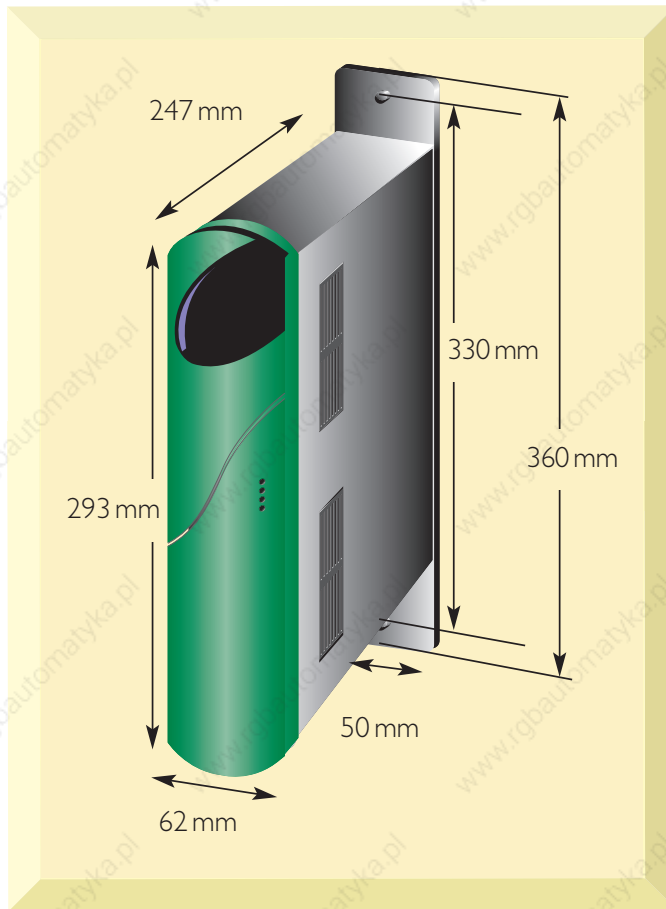

M'Ax
Dimensions: Options

OPTIONS

M'Ax Soft

M'AxSoft is a Windows™ based drive set-up program that is designed to enable the complete control and display of all parameters within a M'Ax drive. M'AxSoft provides the user with a graphical interface that is logically split into a series of screens, offering the quick and easy viewing and where appropriate editing of a parameter value. Individual detailed parameter information can at any time be displayed defining the parameters function, type and min/max permitted value.

Drive Setup Wizard

- A drive setup wizard reads the motor data from the module
- Dynamic braking can be selected and wiring is shown for internal or external braking
- Speed input reference options are shown pictorially, enabling the user to visualise their selection
- Drive feedback is shown pictorially and allows analogue outputs to be set along with Simulated Encoder output
- Load inertia and drive stiffness can be entered and sent to the drive which calculates PID values for the gain selector
- A backup power supply can be selected and configured
- Help is provided for each step in the setup wizard



Unimotor (SLM)

OVERVIEW

The (SLM) version of Unimotor is fitted with (SLM) **technology** electronic feedback that operates with Control Techniques M'Ax and MultiAx drives. This motor-drive combination offers extremely high resolution, for superb system speed control. High resolution is essential for many system applications where speed and position errors must be minuscule.

The feedback comprises of Sincos encoder and electronics, both contained within the standard Unimotor body. The encoder has a memory programmed with all the essential motor characteristics necessary to automatically set all M'Ax parameters, giving an instant 'Plug and Play' capability.

The Unique 'finned' design improves heat dissipation, and with its single piece design optimises torque output and reduces cogging torque. The compact design gives additional torsional stiffness.

Laminations and coils are optimised to give high efficiency and low harmonic distortion. All this combined with high energy magnets and a choice of rotor inertia, give Unimotor truly dynamic performance to suit all applications.

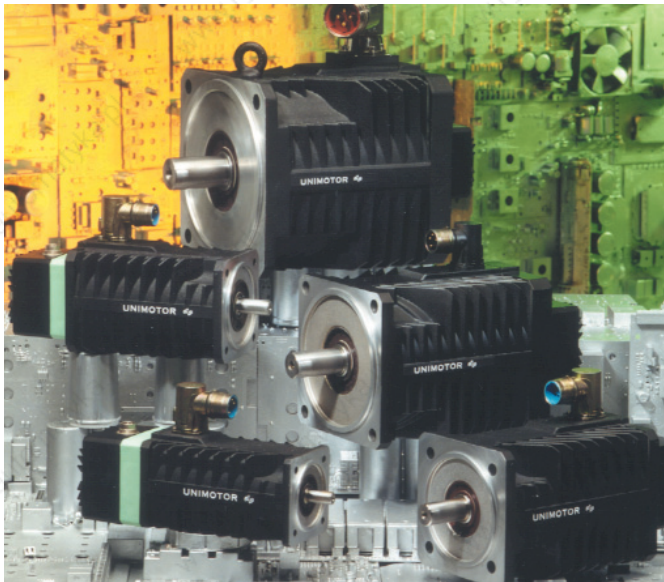

SPECIFICATION

Standard motors have UL and CAN/CSA recognised Insulation System to class. The CTD/IS/2000/01 insulation system number on the motor number plate, together with the symbol, denotes this. Earlier motors may display this information on a separate label on the rear cover.

If the UL symbol has "E215243" underneath, then this indicates full motor recognition.

Machinery Directive 89/392/EEC amended to 98/37/EC

Low Voltage Directive 73/23/EEC

- EN 60034 General requirements for rotating electrical machinery
- EN 60034-1 Duty: S1 Continuous
Storage: -15°C to 40°C Operating: Min ambient 0°C; max ambient 40°C
Less than 1000m altitude
Relative humidity: 90% Non condensing
- EN 60034-5 Degree of Ingress protection: IP65S (with mating connector & cable fitted)
- EN 60034-6 Method of cooling: free circulation, free convection
- EN 60034-7 Flange mounted: horizontally or vertically
- EN 60034-8 Terminal markings: U V W
- EN 60034-11 Thermal protection: PTC thermistor; 165°C TPI 111 (Not SL variants)
- EN 60034-18 Insulation system: Class H 600V, UL number E214439
- EN 60072 Dimensions and output for rotating electrical machines
- EN 60072-1 Type N (Customer variants)
- ISO 1940-1 Balancing: to G6.3, (ISO8821 half key convention)

Equipment is not deemed suitable for use in an explosive atmosphere.

This product has been designed to be operated with Control Techniques drives and must not be put into service unless the machinery into which it is to be incorporated has been declared in conformity with the provisions of the machinery directive.

DIMENSIONS (mm)

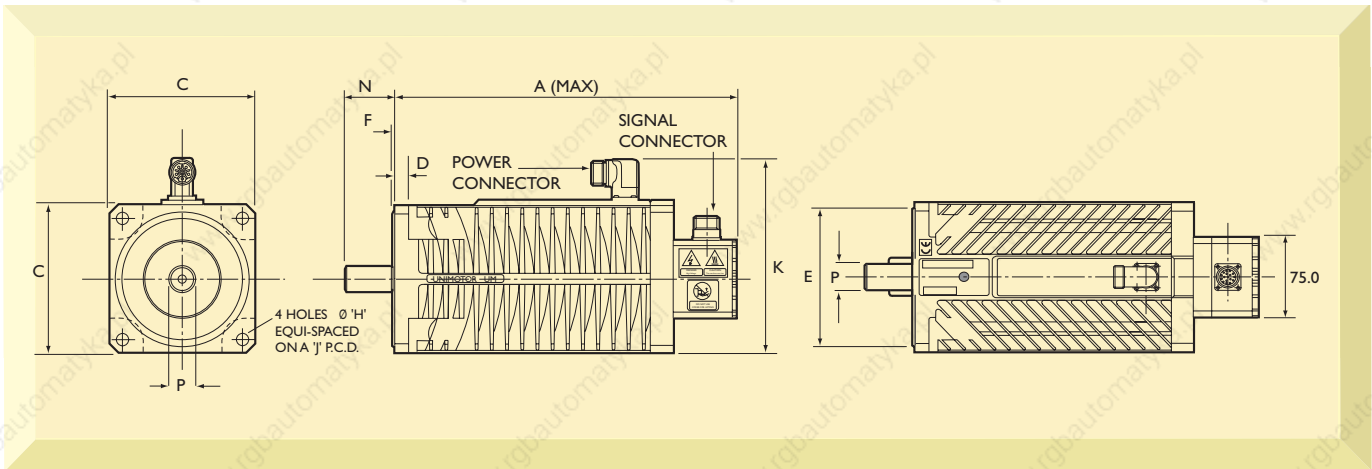

Ref	Description	75A	75B	75C	75D	95A	95B	95C	95D	95E	115A	115B	115C	115D	115E	142A	142B	142C	142D
A	Length overall (unbraked)	211	241	271	301	222	252	282	312	342	242	272	302	332	362	225	255	285	315
A	Length overall (braked)	241	271	301	331	252	282	312	342	372	272	302	332	362	392	285	315	345	375
C	Flange Square	75	75	75	95	95	95	95	95	115	115	115	115	115	115	142	142	142	142
D	Flange Thickness	7	7	7	7	9	9	9	9	9	11	11	11	11	11	12.3	12.3	12.3	12.3
E	Register Diameter (I6)	60	60	60	60	80	80	80	80	80	95	95	95	95	95	130	130	130	130
F	Register Length	2.4	2.4	2.4	2.4	2.9	2.9	2.9	2.9	2.9	2.9	2.9	2.9	2.9	2.9	3.4	3.4	3.4	3.4
H	Fixing Holes Diameter (H14)	5.8	5.8	5.8	5.8	7	7	7	7	7	10	10	10	10	10	12	12	12	12
J	Fixing Hole p.c.d	75	75	75	75	100	100	100	100	100	115	115	115	115	115	165	165	165	165
K	Overall Height	126	126	126	126	146	146	146	146	146	166	166	166	166	166	193	193	193	193
N	Shaft Length (front)	23	30	30	30	30	40	40	40	40	40	40	40	50	50	50	50	50	50
P	Shaft Diameter (front)	11	14	14	14	14	19	19	19	19	19	19	19	24	24	24	24	24	24

PERFORMANCE DATA

Unimotor (SLM) servo motor technical specification For 3 Phase VPWM Drives 380 - 480Vrms

Motor Frame Size (mm)		75				95					115					142			
All Speeds	Frame Length	A	B	C	D	A	B	C	D	E	A	B	C	D	E	A	B	C	D
Continuous Stall Torque (Nm)		1.2	2.2	3.1	3.9	2.3	4.3	5.9	7.5	9.0	3.5	6.6	9.4	12.4	15.3	6.3	10.8	15.3	19.8
Peak Torque (Nm)		3.6	6.6	9.3	11.7	6.9	12.9	17.7	22.5	27.0	10.5	19.8	28.2	37.2	45.9	18.9	32.4	45.9	59.4
High Inertia (kgcm ²)		1.2	1.6	2.1	2.5	3.5	4.5	5.6	6.7	7.8	9.7	12.0	14.3	16.6	18.8	21.6	28.0	34.3	40.7
Standard Inertia (kgcm ²)		0.6	1.0	1.5	1.9	1.4	2.5	3.6	4.7	5.8	3.2	5.5	7.8	10.0	12.3	7.8	14.1	20.5	26.8
Weight (kg)		3.0	3.7	4.4	5.1	5.0	6.1	7.2	8.3	9.5	6.5	8.2	9.9	11.6	13.2	10.9	13.2	15.5	17.8
Winding Thermal Time Const.(sec)		81	74	94	100	172	168	183	221	228	175	185	198	217	241	213	217	275	301
Maximum Cogging (Nm)		0.02	0.03	0.04	0.05	0.03	0.06	0.08	0.10	0.13	0.06	0.10	0.14	0.18	0.21	0.09	0.16	0.23	0.30
Rated Speed 2000 (rpm)		Stall torque; rated torque and power relate to maximum continuous operation in a 40°C ambient All data subject to +/-10% tolerance																	
Rated Speed 2000 (rpm)		Kt (Nm/A) 2.40 Ke (V/krpm) 147 Ke(NOM) = 147 V/krpm																	
Rated Torque (Nm)		1.1	2.1	3.0	3.8	2.2	4.0	5.5	6.9	8.2	3.2	6.1	8.7	10.8	14.0	5.9	10.3	14.6	18.4
Continuous Stall Current (A)		0.5	1.0	1.3	1.7	1.0	1.8	2.5	3.2	3.8	1.5	2.8	4.0	5.2	6.4	2.7	4.5	6.4	8.3
Rated Power (kW)		0.23	0.44	0.63	0.80	0.46	0.84	1.15	1.45	1.72	0.67	1.28	1.82	2.26	2.93	1.24	2.16	3.06	3.85
R (ph-ph) (Ohms)		144	48.2	25.0	15.7	59.0	17.0	9.90	6.00	4.30	27.8	8.55	4.55	2.96	2.17	12.5	3.60	2.10	1.35
L (ph-ph) (mH)		214	99.2	59.2	44.7	131	54.5	36.5	25.6	18.9	94.6	40.5	25.7	18.6	14.7	58.0	29.8	18.7	13.6
Rated Speed 3000 (rpm)		Kt (Nm/A) 1.60 Ke (V/krpm) 98 Ke(NOM) = 98 V/krpm																	
Rated Torque (Nm)		1.1	2.0	2.8	3.5	2.0	3.9	5.4	6.8	8.1	3.0	5.5	8.1	10.4	12.6	5.4	9.0	12.2	15.8
Continuous Stall Current (A)		0.8	1.4	2.0	2.5	1.5	2.7	3.7	4.7	5.7	2.2	4.2	5.9	7.8	9.6	4.0	6.8	9.6	12.4
Rated Power (kW)		0.35	0.63	0.88	1.10	0.63	1.23	1.70	2.14	2.54	0.94	1.73	2.54	3.27	3.96	1.70	2.83	3.83	4.96
R (ph-ph) (Ohms)		60.8	20.1	10.5	7.5	24.5	6.80	4.00	2.50	2.00	12.6	3.86	2.02	1.40	1.10	5.63	1.72	0.94	0.61
L (ph-ph) (mH)		98.4	41.8	27.6	19.7	57.9	24.3	15.5	10.9	8.50	43.1	18.6	11.4	8.60	7.40	31.0	13.3	8.30	6.10
Rated Speed 4000 (rpm)		Kt (Nm/A) 1.20 Ke (V/krpm) 73.5 Ke(NOM) = 73.5 V/krpm																	
Rated Torque (Nm)		1.0	1.7	2.3	2.9	1.8	3.0	4.0	4.9	5.7	2.5	4.7	6.3	7.5	8.7	3.6	7.0	8.9	10.7
Continuous Stall Current (A)		1.0	1.9	2.6	3.3	2.0	3.6	5.0	6.3	7.5	3.0	5.5	7.9	10.4	12.8	5.3	9.0	12.8	16.5
Rated Power (kW)		0.42	0.71	0.96	1.21	0.75	1.26	1.68	2.05	2.39	1.05	1.97	2.64	3.14	3.64	1.51	2.93	3.73	4.48
R (ph-ph) (Ohms)		36.8	10.5	6.30	4.20	12.7	4.08	2.10	1.50	1.03	6.91	2.14	1.16	0.73	0.57	3.12	1.00	0.53	0.35
L (ph-ph) (mH)		54.9	24.8	14.9	10.8	31.5	13.6	8.50	6.30	4.80	23.5	10.2	6.60	4.70	3.90	17.6	7.50	4.70	3.60
Rated Speed 6000 (rpm)		Kt (Nm/A) 0.80 Ke (V/krpm) 49 Ke(NOM) = 49.0 V/krpm																	
Rated Torque (Nm)		0.9	1.6	2.1	2.6	1.3	2.1	2.8	3.3	3.7	2.2	4.0	5.1	▲	N/A	2.9	4.5	▲	▲
Continuous Stall Current (A)		1.5	2.8	3.9	4.9	2.9	5.4	7.4	9.4	11.3	4.4	8.3	11.8			7.9	13.5		
Rated Power (kW)		0.57	1.01	1.32	1.63	0.82	1.32	1.76	2.07	2.32	1.38	2.51	3.20			1.82	2.83		
R (ph-ph) (Ohms)		15.0	5.00	2.66	1.90	5.45	1.82	1.05	0.62	0.48	3.1	0.97	0.50			1.42	0.46		
L (ph-ph) (mH)		24.0	10.6	6.80	4.80	14.1	6.00	3.80	2.70	2.10	15.54	4.81	2.94			7.72	3.44		

N/A Not Available

▲ Consult factory

The information contained in this specification is for guidance only and does not form part of any contract. Control Techniques Dynamics Limited have an ongoing process of development and reserve the right to change the specification without notice.

M'Ax AND UNIMOTOR (SLM) SELECTION

Reference No.	Motor Type (#) 3000rpm Kt (1.6Nm/A rms)	Drive Type	Stall Torque (Nm)	Stall Current (Arms)	Peak Torque (Nm)	Torque @ 3000rpm (Nm)	Standard Inertia(*) (kgcm ²)	Motor Weight (kg)
1	75SLA300CBPAA	M'Ax 403	1.2	0.8	3.6	1.1	0.6	3.5
2	75SLB300CBPAA	M'Ax 403	2.2	1.4	6.3	2.0	1.0	4.3
3	75SLC300CBPAA	M'Ax 403	3.1	2.0	8.4	2.8	1.5	5.1
4	75SLD300CBPAA	M'Ax 403	3.9	2.5	10.8	3.5	1.9	5.8
5	95SLA300CBPAA	M'Ax 403	2.3	1.5	6.9	2.0	1.4	4.7
6	95SLB300CBPAA	M'Ax 403	4.3	2.7	11.2 (†)	3.9	2.5	6.1
7	95SLC300CBPAA	M'Ax 403	5.9	3.7	17.77 (†)	5.4	3.6	7.2
8	95SLD300CBPAA	M'Ax 406	7.5	4.7	20.7	6.8	4.7	8.8
9	95SLE300CBPAA	M'Ax 406	9.0	5.7	20.8 (†)	8.1	5.8	10.4
10	I15SLA300CBPAA	M'Ax 403	3.5	2.2	11.2 (†)	3.0	3.2	7.3
11	I15SLB300CBPAA	M'Ax 406	6.6	4.2	19.0	5.5	5.5	8.8
12	I15SLC300CBPAA	M'Ax 406	9.4	5.9	20.8 (†)	8.1	7.8	10.6
13	I15SLD300CBPAA	M'Ax 409	12.4	7.8	30.4 (†)	10.4	10.0	12.5
14	I15SLE300CBPAA	M'Ax 409	15.3	9.6	40.4 (†)	12.6	12.3	14.2
15	I42SLA300CBPAA	M'Ax 406	6.3	4.0	18.9	5.4	7.8	9.4
16	I42SLB300CBPAA	M'Ax 409	10.8	6.4	30.4 (†)	9.0	14.1	12.1
17	I42SLC300CBPAA	M'Ax 412	15.3	9.6	40.0	12.2	20.5	14.7

Preferred stocking frames are B and D. For other combinations - consult Drive Centre.

(#): Motors in table are connectorised, no brake, no key - plain shaft, IEC flange, standard inertia.

Other base speeds are 2000rpm (2.4Nm/A rms), 4000rpm (1.2Nm/A rms); 6000rpm also available

Options available: Brake, cable assemblies, planetary gearboxes, keyed shaft

(†): Motor is capable of higher peak torques when used with next higher rating M'Ax.

(*): Higher inertia rotors are available as options.

M'Ax AND UNIMOTOR (SLM) SPEED TORQUE CURVES

(2) 75SLB300 with M'Ax 403

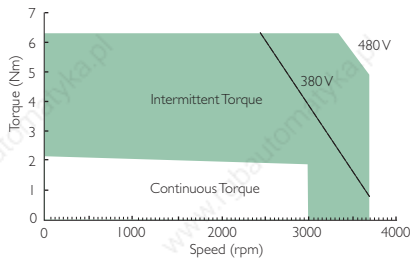

(3) 75SLC300 with M'Ax 403

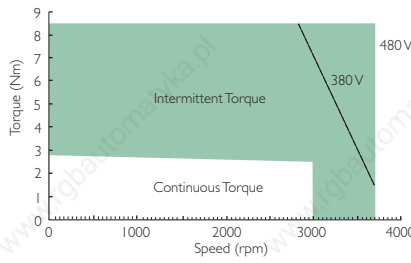

(4) 75SLD300 with M'Ax 403

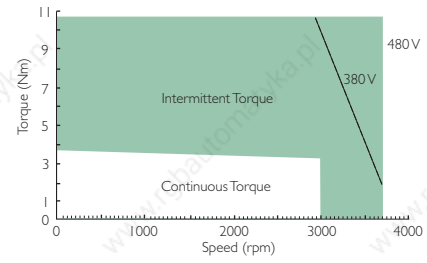

(5) 95SLA300 with M'Ax 403

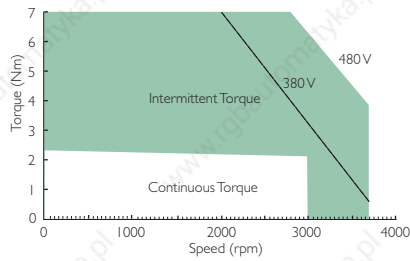

(6) 95SLB300 with M'Ax 403

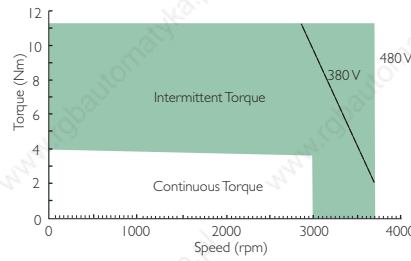

(7) 95SLC300 with M'Ax 403

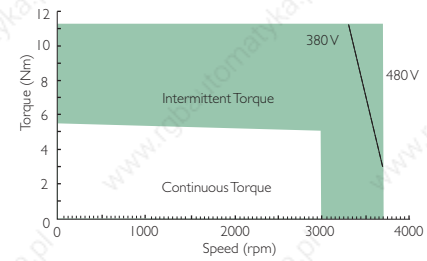

(8) 95SLD300 with M'Ax 406

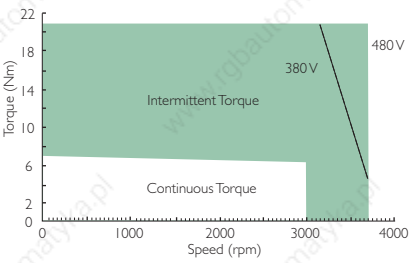

(9) 95SLE300 with M'Ax 406

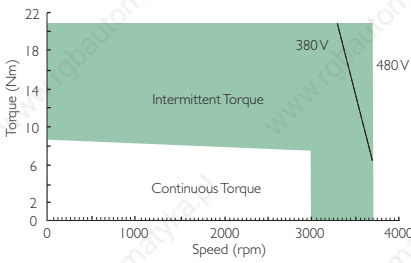

(11) 115SLB300 with M'Ax 406

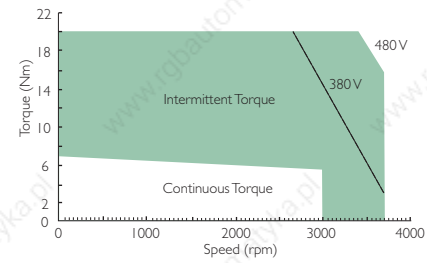

(12) 115SLC300 with M'Ax 406

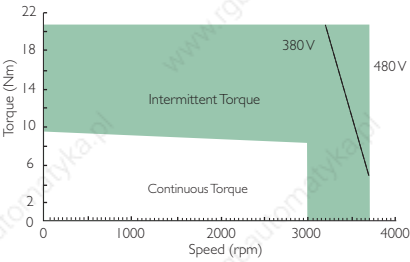

(13) 115SLD300 with M'Ax 409

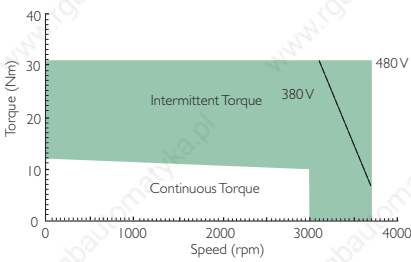

(14) 115SLE300 with M'Ax 409

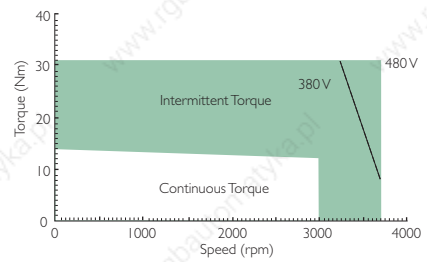

(16) 142SLB300 with M'Ax 409

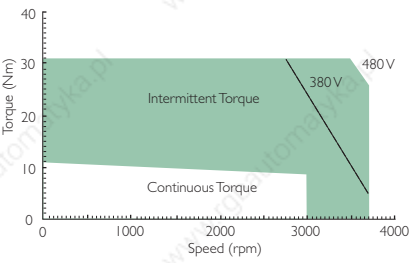

(17) 142SLC300 with M'Ax 412

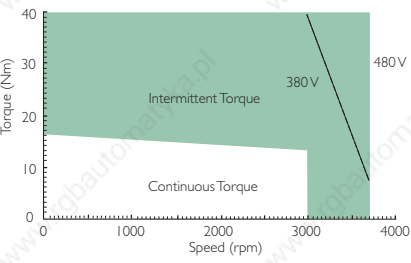

(18) 142SLD300 with M'Ax 412

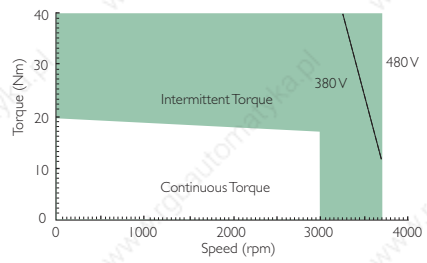

40°C Ambient, up to $\Delta t 100^\circ\text{C}$; 10% tolerance on all performance data

Unimotor (SLM) Power Cable selection

Cable type – PS for motor without brakes, PB for motors with brake.

Jacket – B is for a PUR sheath and is the standard selection. A is for a PVC sheath to be used on the DS brake cable only.

Conductor Size – Select the conductor size according to the motors STALL CURRENT.

Include forced cooling performance if applicable.

Cables of 6mm² and above will be fitted with ring terminals only.

Ratings are for individual cables (not lashed together) in free air temperature up to 40°C - make allowances as appropriate.

Connection detail drive end – Select the correct drive end connection for the drive in use.

Connection detail motor end – Select the correct motor end connection for the motor in use.

Length – Numbers represent the required cable length in metres. Conversion cables will be limited to 0.4m only and the length is not required in the order code.

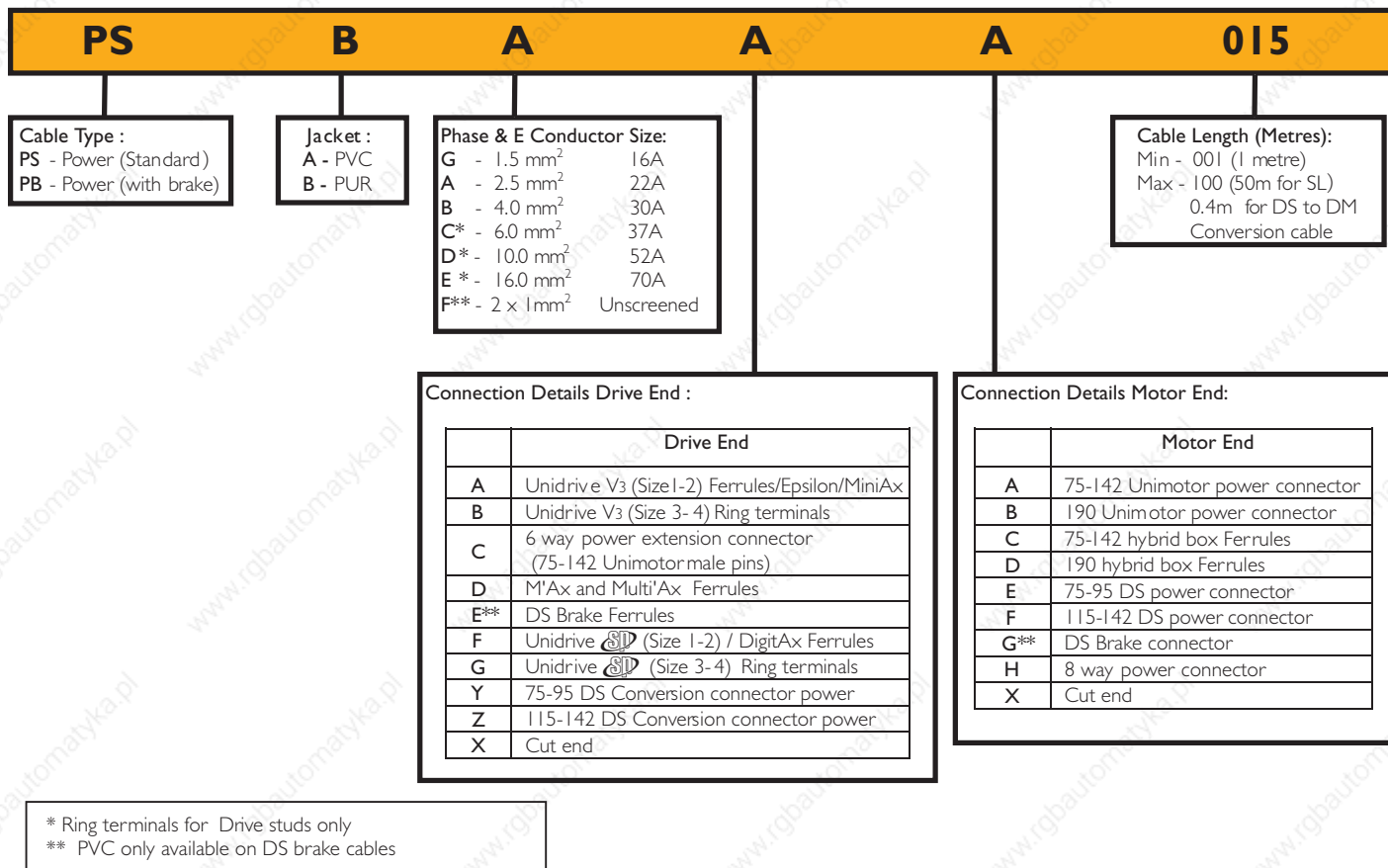

Unimotor (SLM) Signal Cable selection

Cable type – Choose the cable type to match the feedback device.

Jacket – B is for a PUR sheath and is the standard selection.

Special options – A is for standard cable. L is for the low cost 8.5mm incremental cable.

Connection detail drive end – Select the correct drive end connection for the drive in use.

Connection detail motor end – Select the correct motor end connection for the motor feedback device in use.

Length – Numbers represent the required cable length in metres. Conversion cables will be limited to 0.4m only and the length is not required in the order code.

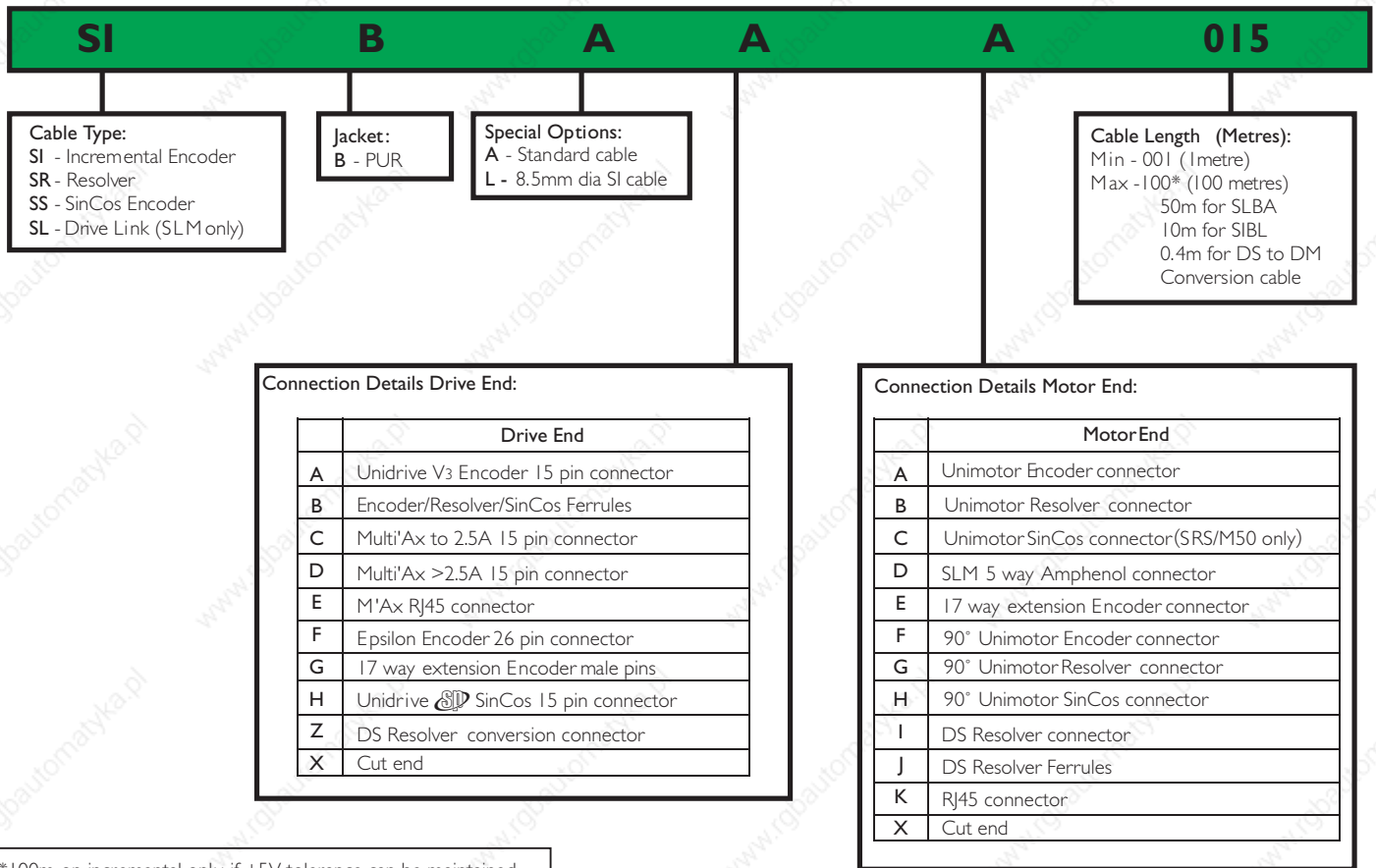

MiniAx



OVERVIEW

The MiniAx is an ultra compact and robust ac brushless servo module designed to meet a wide range of automation applications. The cost effective but dynamic design has made MiniAx the perfect partner for OEMs who are searching for a compact reliable servo package that offers superior performance. Designed for applications where the dynamic, accurate control of the position, velocity and torque loop are critical MiniAx and its performance matched MM55 motor range have helped improve machine productivity.

FEATURE PERFORMANCE

- Trapezoidal 3 phase brushless servo
- Rugged, compact footprint
- Designed for chassis mounting (IP00)
- Pluggable terminals for simple installation and replacement
- High switching frequency (22kHz) for low audible noise and current ripple
- Encoder feedback as standard
- Torque or speed control with torque override
- Diagnostics include; short circuit, under and over voltage, over temperature, and loss of hall sensor
- Positive or negative logic

RATINGS

Model Order Code	Input Voltage (VDC)	Rated Current (A)	Peak Current (for 2s)
MiniAx 60*5/10	20-80	5	10
MiniAx60*10/20	20-80	10	20

TERMINAL DIAGRAM & DESCRIPTION

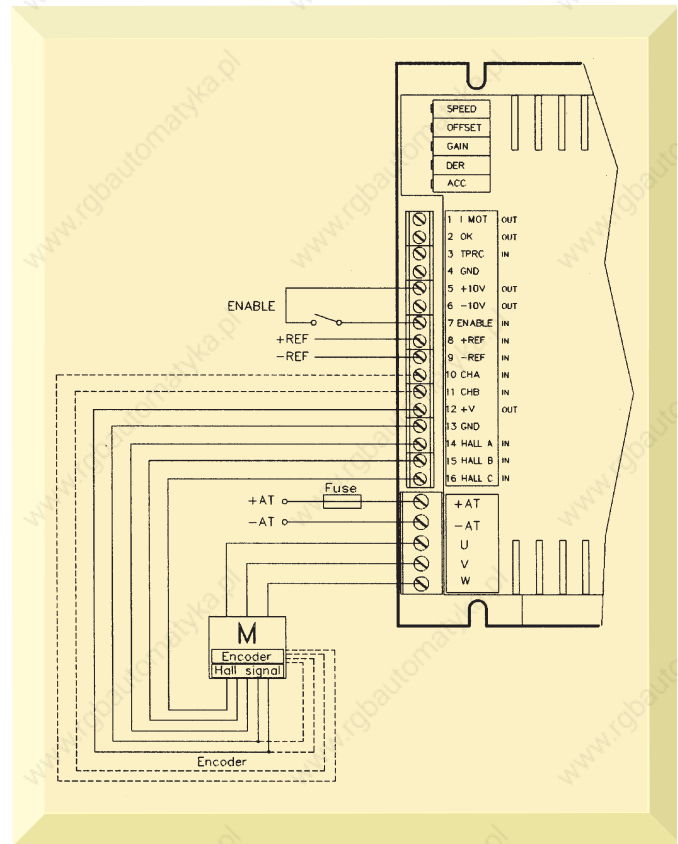

SPECIFICATION

Environment

Ambient Operating Temperature	0 to 40°C
Cooling Method	Convection
Humidity	95% non-condensing at 40°C
Storage Temperature	-40 to 50°C
Altitude	Up to 2000m
Enclosure	Chassis (IP00)

Control

Analogue reference	±1.10V
Auxiliary Power supply	±1.10VDC (4mA)
Encoder Supply	5VDC (130mA)
Max encoder frequency	250kHz
Enable signal	+10 to 30VDC
Current loop bandwidth	2.5kHz

Protection

- External short circuit trip
- Under voltage trip
- Over voltage trip
- Heatsink over temperature trip
- Loss of Hall sensor trip

Approval and listings



DIMENSIONS (mm)

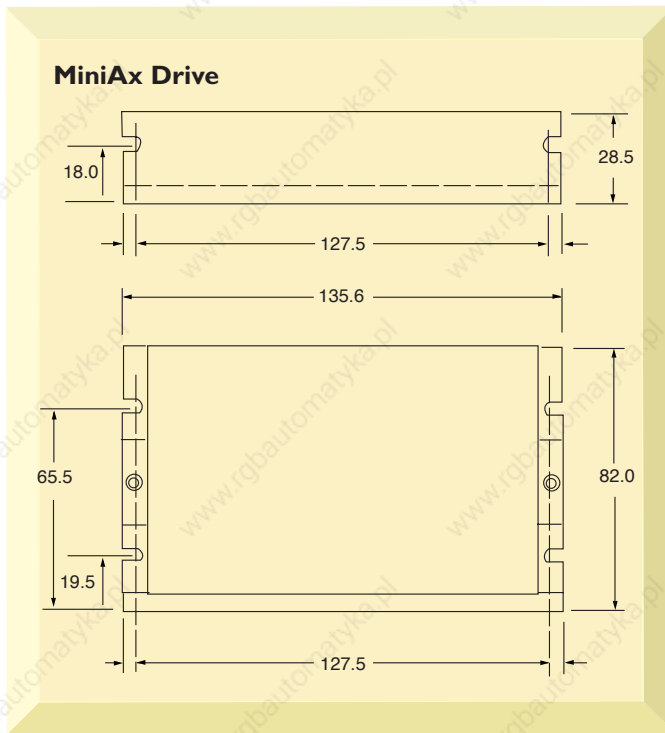

MM55 AC Brushless Motor

OVERVIEW

The MM55 AC brushless permanent magnet servo motor was designed to respond to the demands for a low cost high performance motor for use with the MiniAx servo controller. Being brushless there is no maintenance requirement and the laminated construction gives a very high torque/inertia ratio which is perfect for applications requiring high performance in a small space. Shaft performance feedback is through a standard incremental encoder.

SPECIFICATION

- MM55 comes in three frame sizes across the range 0.55Nm to 1.35Nm
- Insulation to class F
- Low rotor inertia as standard for dynamic performance
- Assembled using rare earth magnets
- Winding vacuum impregnated for mechanical strength and thermal performance
- Protection to IP55
- Incremental Encoder feedback with +5VDC with A, B, Z and commutation outputs as differential RS485 drivers (20mA)
- Optional brake available with 1.1Nm static rating for normal parking and a dynamic rating of 0.75Nm for infrequent use
- 24VDC power requirement for brake option

DIMENSIONS (mm)

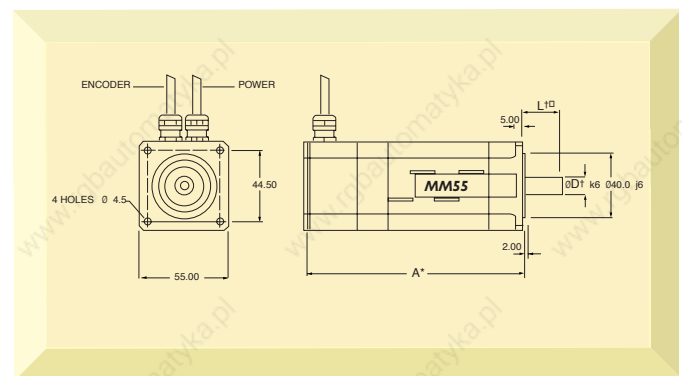

Motor Length	A	B	C
Length - No brake (A*)	106	136	166
Length - Braked (A*)	141	171	201
Weight - No brake (kg)	1.1	1.6	2.0
Weight - Braked (kg)	1.5	2.0	2.4
Shaft (L [†] xD [†])	20x9	23x11	23x11

MINIAX AND MM55 SELECTION CHART

MiniAx drive type	60x5/10		60x10/20		
Motor Length	A30	B30	C30	A50	B50
Stall torque (Nm)	0.65	1.08	1.35	0.55	0.70
Peak torque (Nm)	1.4	2.7	2.7	1.4	1.4
Stall current (A)	4.7	7.9	10	7.8	10
Peak current (A)	10	20			
Nominal speed (rpm)	3000			5000	
Ke ac (Vrms/krpm)	11.6			5.9	
Encoder feedback (ppr)	2048			1024	
Rotor inertia (Kgcm ²) Unbraked	0.12	0.22	0.32	0.12	0.22
Motor poles	8				
Motor temperature rise (°C)	80	80	50	80	50
Ambient temperature (°C)	operates up to 40°C ambient				
Back EMF (Vac)	60				
Insulation class	F				

MM55 Ordering Information

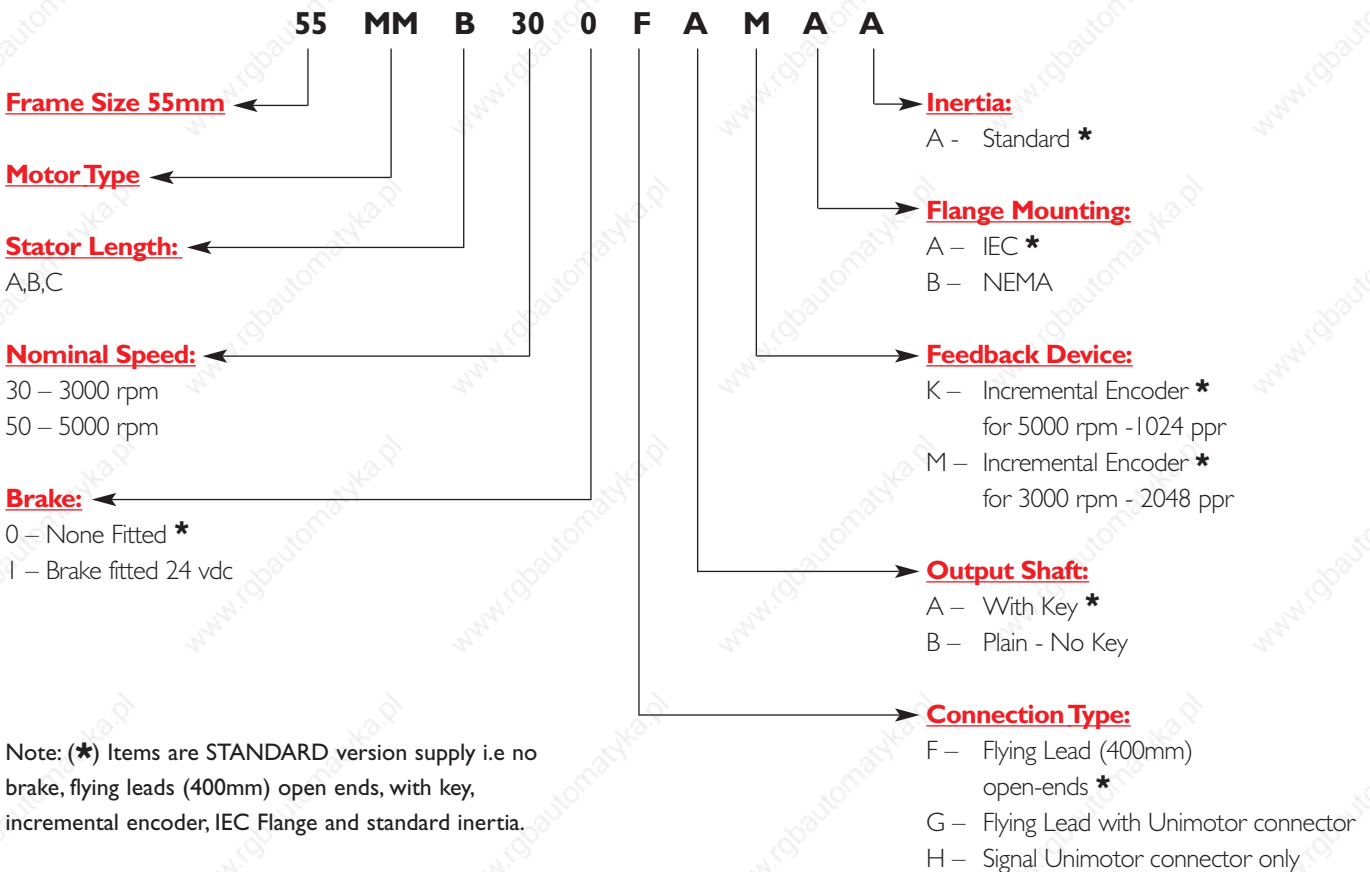

SPEED TORQUE CHARACTERISTICS

3000 rpm

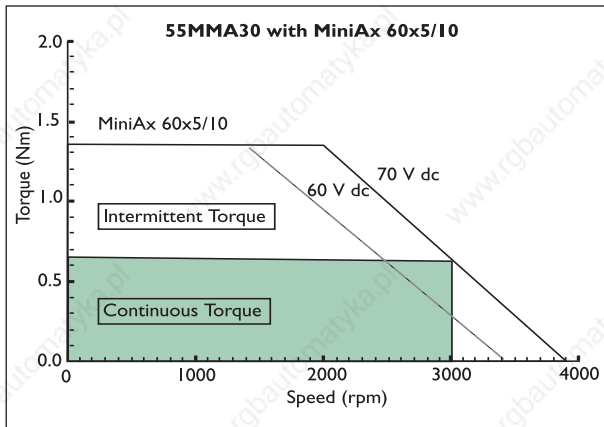

5000 rpm

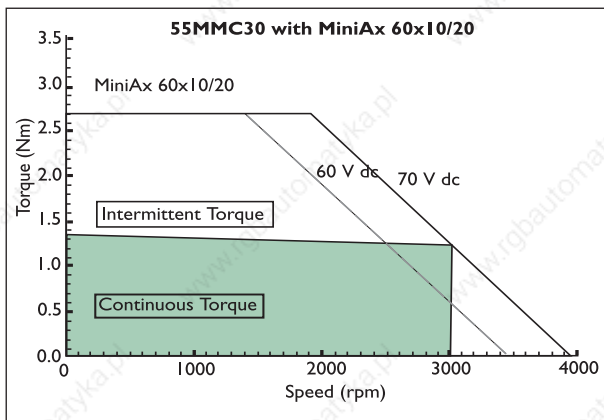
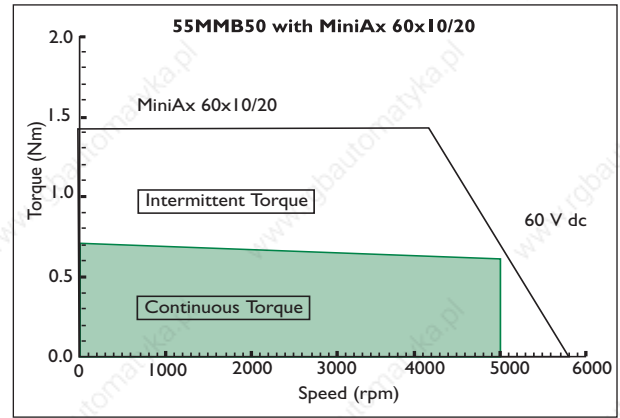
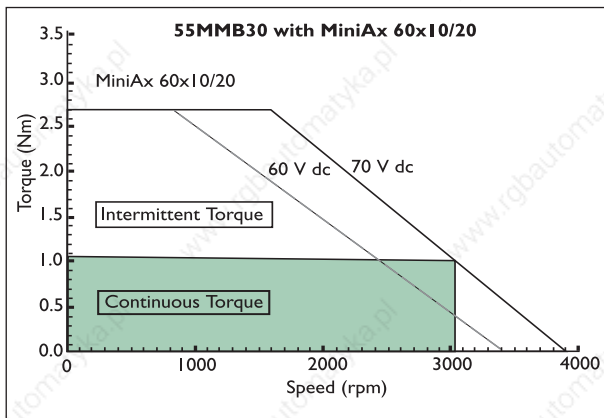
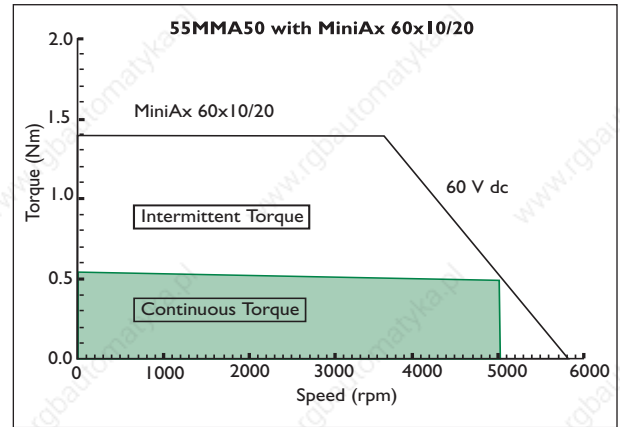

Tests conducted at 25°C room temperature with MiniAx supply at 60VDC and 70VDC

MM55 Power Cable selection

Cable type – PS for motor without brakes, PB for motors with brake.

Jacket – B is for a PUR sheath and is the standard selection. A is for a PVC sheath to be used on the DS brake cable only.

Conductor Size – Select the conductor size according to the motors STALL CURRENT.

Include forced cooling performance if applicable.

Cables of 6mm² and above will be fitted with ring terminals only.

Ratings are for individual cables (not lashed together) in free air temperature up to 40°C - make allowances as appropriate.

Connection detail drive end – Select the correct drive end connection for the drive in use.

Connection detail motor end – Select the correct motor end connection for the motor in use.

Length – Numbers represent the required cable length in metres. Conversion cables will be limited to 0.4m only and the length is not required in the order code.

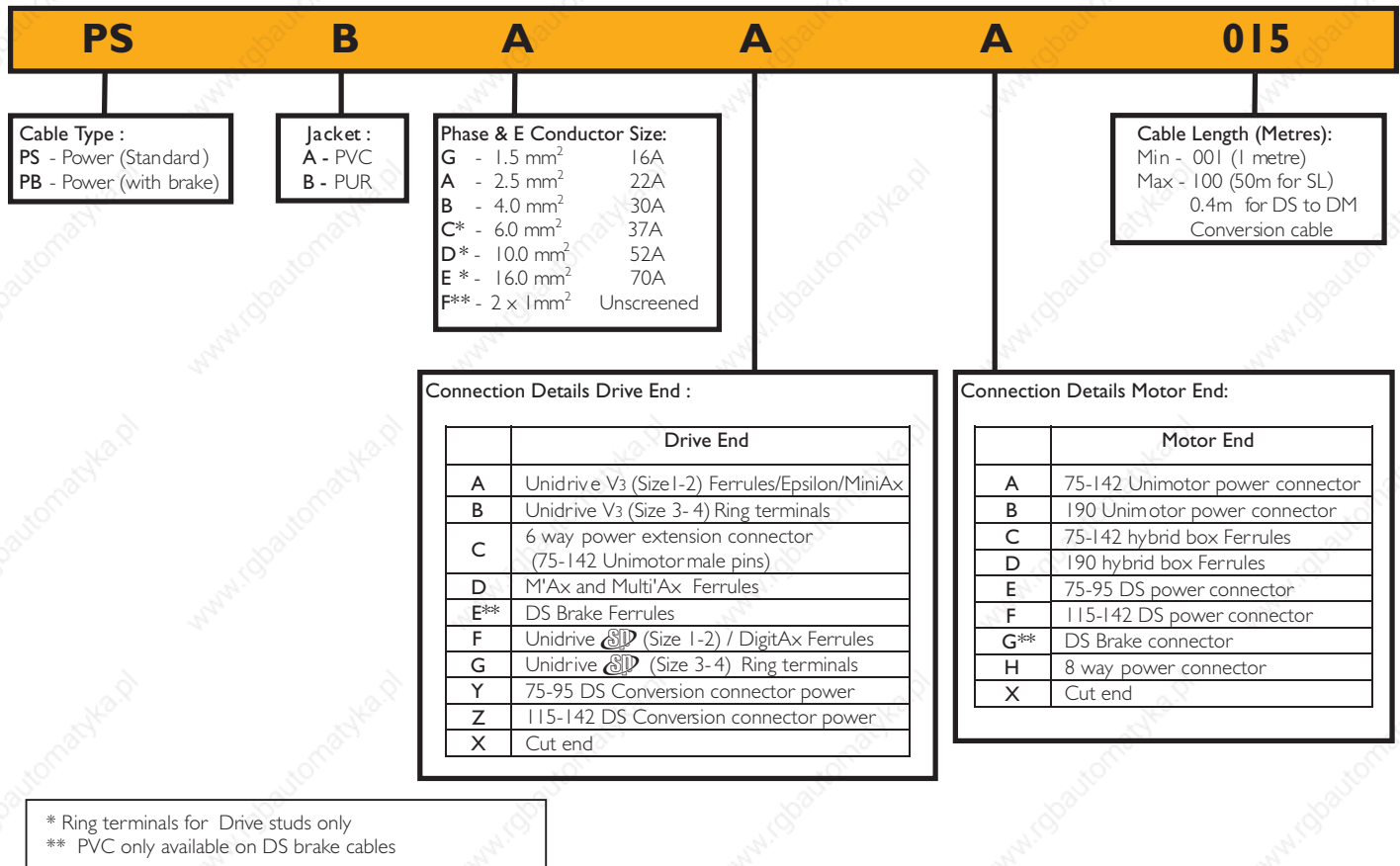

MM55 Signal Cable selection

Cable type – Choose the cable type to match the feedback device.

Jacket – B is for a PUR sheath and is the standard selection.

Special options – A is for standard cable. L is for the low cost 8.5mm incremental cable.

Connection detail drive end – Select the correct drive end connection for the drive in use.

Connection detail motor end – Select the correct motor end connection for the motor feedback device in use.

Length – Numbers represent the required cable length in metres. Conversion cables will be limited to 0.4m only and the length is not required in the order code.

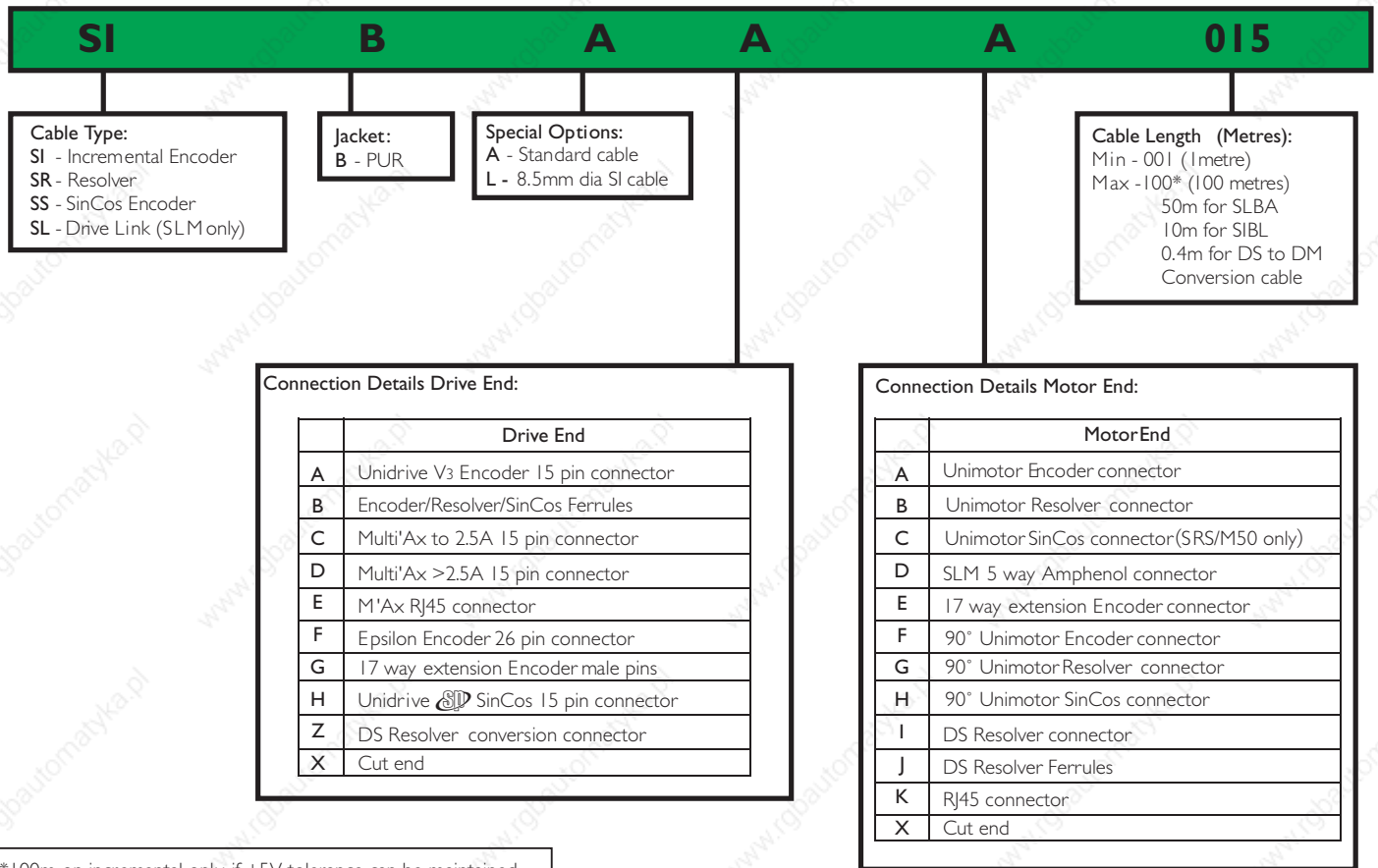

Motion Control Solutions

OVERVIEW

The choices of approach for AC motion control are wide and varied. The machine or process designer has a huge variety of machine, control and automation variables to assess and understand before deciding on the solution that best fits the needs of the process or machine.

This overview is designed to help users with the selection of a motion control solution that best suits their needs. Control Techniques engineers are familiar with the automation decisions faced and the possible solutions that will fit best and we recommend customers discuss their application in detail with their local Drive Centre/ Distributor.

For both PLC and Motion functionality the choice of solution is heavily biased towards the Automation hierarchy that exists or is best suited to the application.

The choices can be summed up as follows:

Decentralised Motion Control

- Drive based processor intelligence for Motion control

Centralised Control

- PLC based Motion control
- PC based Motion control
- Motion controller based

Hybrid Motion Control

- PLC, PC or Motion Controller with sectional control done via drive based intelligence



Typically large multi-axes applications have been the domain of the centralised approach favoured by PLC based motion control suppliers but with the advent of PC based and other motion controllers the choice is now much wider.

However with drives having more and more intelligence on board or available through options, the Solutions Platform drives such as Unidrive have been championing the decentralised solution as being more practical, more scalable to the size of application and more cost effective.

This is certainly true of simple point to point and 1/2 axis motion control which is firmly in the domain of decentralised drive based intelligence, and makes up a large slice of today's high performance servo market.



DECENTRALISED MOTION CONTROL

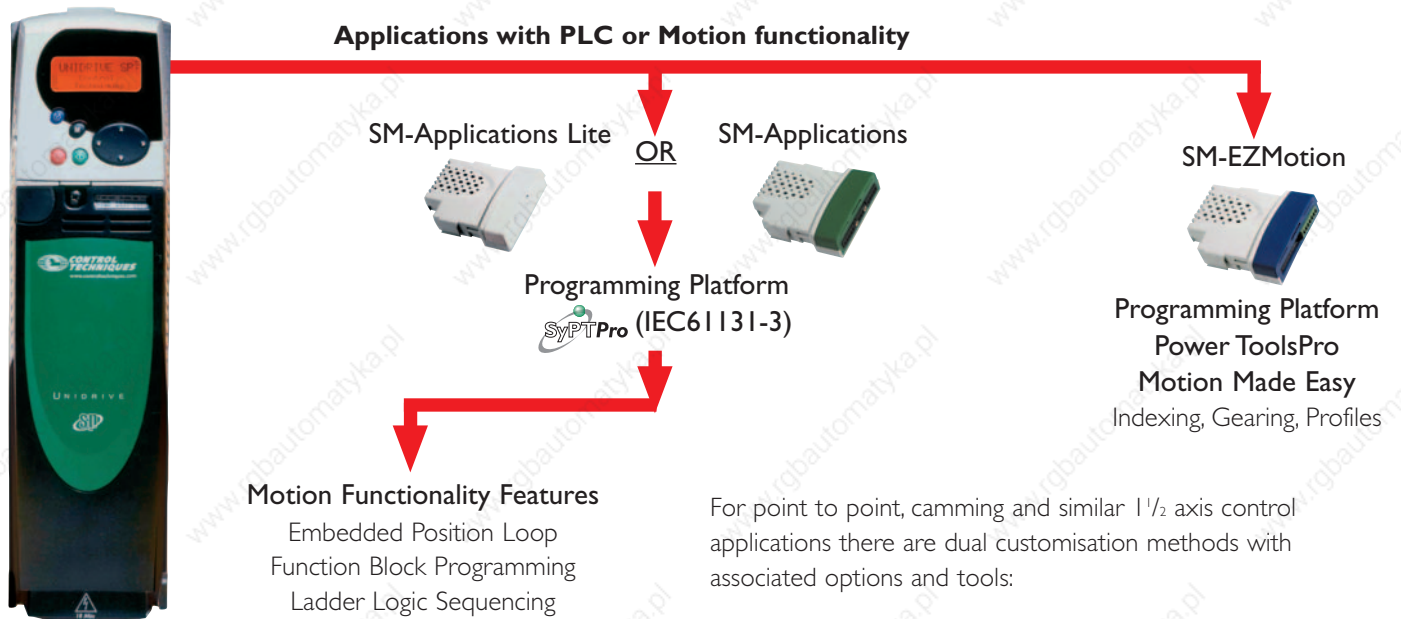

OVERVIEW

Today's machine designers and users aim to find the most cost effective method of achieving advanced machine control through the optimum deployment of processing resource, software and hardware.

The scalability of Unidrive SD, with its choice of programming options and tools, enables users to implement the correct level of PLC logic/Motion code and machine control for their applications.

Either convenient Motion Made Easy approach...

- Perfect match for machines and applications that are:
 - Low volume/low engineering time/ high performance
- SM-EZ Motion option module
- Simple 5 step process

Or SyPTPro IEC 61131-3 based approach....

- Perfect match for machines and applications that are:
 - High volume/high performance
- Standard PLCopen Motion Programming Environment
- Different levels of scalable customisation
 - On-board (no-options)
 - SM-Applications Lite
 - SM-Applications

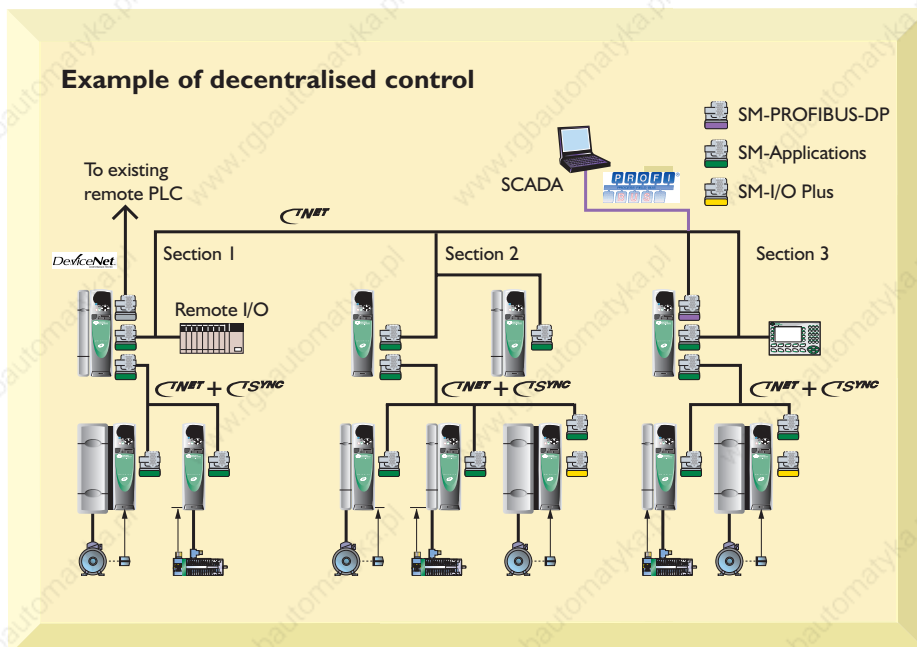

ULTIMATE FLEXIBILITY

The flexibility of the Unidrive SD together with the option module range makes the Unidrive SD the perfect Solutions Platform for any automation system.

The SM-Applications option modules can be used in almost unlimited combinations with fieldbus and I/O options in order to neatly dovetail into existing automation systems.

Alternatively, when starting out with a clean sheet of paper, the Unidrive SD can achieve the necessary cost and space savings by allowing the Project Engineer to accurately match the PLC and I/O requirements.

Motion Made Easy™ and PowerTools Pro™

Applications with Motion functionality



SM-EZMotion



Programming Platform -
Power Tools Pro
'Motion Made Easy'

Indexing
Gearing
Profiles

OVERVIEW

Unidrive **SD** the AC servo drive Solutions Platform, packaged with the EZMotion module and free PowerTools Pro™ software means "Motion Made Easy"™ for OEM's, integrators, machine builders and end users.

For most motion control applications, users are looking for fast set up, short software learning curves, and fill-in-the-dialogue-box programming that achieves motion profiles quickly and reliably. The Unidrive **SD** "Motion Made Easy" option has been designed specifically for these users.

SAVINGS

The flexible and scalable architecture of the Unidrive **SD** provides many tangible cost and space saving benefits. Savings derived with "Motion Made Easy" are:

- Internally fitted motion controller, less cabling, speeds installation and reduces the chance of termination errors
- "Hot-pluggable" commissioning that's virtually automatic, simply describe your system hardware in PowerTools Pro and the rest is done for you
- Low learning curve, thorough on-line diagnostics, and other powerful software features enable users to create high-performance motion profiles in minutes

PERFORMANCE

The Unidrive **SD** is easily matched to a wide range of motors and feedback devices to provide optimum performance for nearly any servo or closed loop vector motor application. The "Motion Made Easy" solution provides users with all the power needed for precise functions control:

- Programmable Limit Switches
- User Defined Variables
- High-Speed Position Capture
- Multiple Profile Summation
- S-curve Accel and Decel
- Synchronised Motion
- Homing
- Queuing
- Program Multi-tasking
- Jog
- Indexing
- Gearing

UNIDRIVE **SD** SOLUTIONS PLATFORM

- Global voltage availability, 200V-690V, with full range of industrial output ratings (see Unidrive **SD** servo section or main product brochure)
- High velocity loop bandwidth
- Universal feedback with 12 selectable encoder types, including:
 - Quadrature, SSI, SinCos, Endat, Hiperface
 - Integration with your motor feedback virtually guaranteed
- Cost and space saving design features, including:
 - Secure Disable input as standard to meet EN954-1 cat.3, a must for modern machine builders
 - Integral EMC filter as standard, meets EN61800-3 for global machine conformity
 - Optional zero-space dynamic braking resistors
 - Two additional option slots, which can be used for additional I/O, fieldbus communication support, or second-encoder support
 - 48-96 VDC operation for set up and low-speed operation on mains supply backup

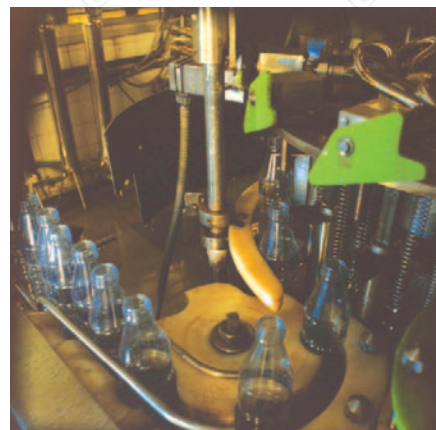

APPLICATIONS CO-PROCESSOR – SM-EZMotion

The SM-EZMotion is a cost effective motion controller which clicks into any of the Unidrive  option slots to give a simple, fast and effective motion solution.

- Precise, reliable motion control using its own internal processor
- Six high-speed, digital I/O points (4 input & 2 output), adding to the seven digital I/O and five analog I/O standard on the Unidrive 
- One-and-a-half axis motion synchronised to a reference encoder (with encoder module)
- Designed to get users up and running quickly with applications such as:
 - Conveyor Synchronisation
 - Electronic Gearing
 - Feed to Sensor/Torque
 - Flying Cutoff
 - Labelling and Printing
 - Multi-Lane Merge Control
 - Parts Alignment
 - Phase Synchronisation
 - Point-to-Point Positioning
 - Product Spacing
 - Random Infeed Control
 - Registration Control
 - Rotary Knife
 - Slip Compensation
 - Thermoforming
 - Traverse Winding
 - Web Control

...and many more!







APPLICATION PROGRAMMING SOFTWARE – PowerTools Pro

PowerTools Pro is a Windows™-based programming software that provides an unparalleled set-up and commissioning environment equally suitable for all skill levels – professional motion control engineer, infrequent user, or someone new to servo systems.

- 'Plug and Play' implementation configures the Unidrive  parameter settings, making hardware setup almost automatic
- Safely program the SM-EZMotion without removing the cover or powering down by using the Modbus RTU port on the front of the Unidrive 
- Data entry simplified using Windows™-based interface
 - Fill-in-the-Dialogue Box values
 - Point-and-Click Radio Buttons
 - Scrolling Menu Selections
 - Drag-and-Drop parameter and I/O assignments
- The Hierarchy view provides instant access to all the tools in PowerTools Pro and is the key to 'Motion Made Easy'



Ordering Motion Made Easy Solutions

Product	Description	Additional Information	Order Code
Unidrive 	AC Servo Drive	Details in the catalogue, Product Brochure and on-line at www.ControlTechniques.com	See section on Unidrive  Servo
SM-EZMotion	Motion Control Module	Solution Module supplied with free PowerTools Pro programming software	SM-EZMotion
PowerTools Pro™	Windows™-based software	Programming software supplied with SM-EZMotion, download from www.ControlTechniques.com	PowerTools Pro™
PC to Drive Cable	Comms Cable	For PC to drive configuration and programming of Unidrive  & SM-EZMotion module	CT Comms cable
Unimotor	AC Servomotor	Details in the catalogue, Product Brochure and on-line at www.ControlTechniques.com	See section on Unidrive  Servo

POWERTOOLS PRO WITH UNIDRIVE AND SM-EZ MOTION

The free PowerTools Pro software in combination with the SM-EZMotion module enables users to fully realise the motion control power of the Unidrive . A familiar Windows™ interface provides operators and machine builders with the tools needed to access everything required for complete servo control – PLS, Queueing, Analog-In, User Variables, High-Speed Capture, Electronic Gearing, Multiple Profile Summation, S-Curve Accel and Decel, Program multitasking, Synchronised motion, and more.

Developing applications with PowerTools Pro is an easy “five-step, top-down” process that quickly gets your applications running. The five task areas that need to be completed in order are found in the Hierarchy View – Hardware, Setup, I/O Setup, Motion, Programs and Network. Some areas may not need completing, as some applications, such as a “flying cutoff” may not require “programming” nor network parameters to operate.

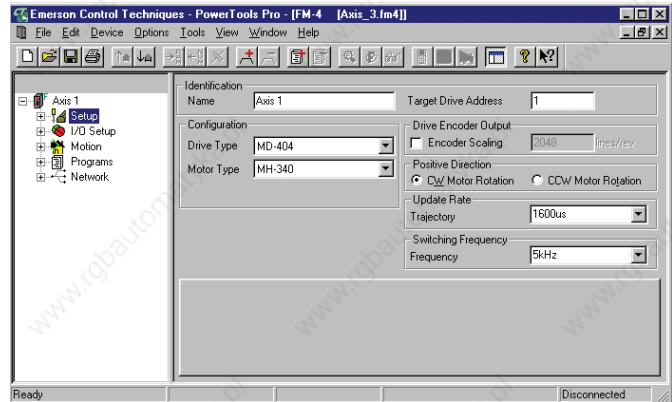

An unexpanded Hierarchy View is shown on the left-hand side of the PowerTools start up screen.

User Units

User Units are the first item under Setup on the PowerTools hierarchy. User Units deliver high resolution performance and ease of use. Motion can be programmed in any units that the user desires. Setup the 32-bit data resolution for position, velocity, and acceleration data one time and the rest is done for you. Select from optional time scales for Velocity and Acceleration units.

Programs

Combine program flow and motion instructions to create fully customised user programs up to 1,000 lines of code. Use conditional branching, wait for, program calls, formulas, user variables, and numerous motion instructions to solve your complex applications. Easily create programs, such as the drill head positioning program below, by dragging and dropping, or typing program instructions, variables, I/O, and formula operands into your program screen. Use the SM-EZMotion module to run one program at a time, or up to four programs simultaneously!

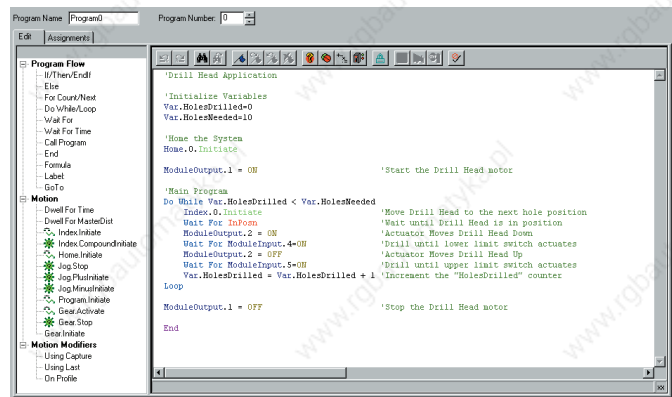

- Programming software for the SM-EZMotion module that gets applications up and running quickly, from the simple to the complex
- Hierarchy View provides for an easy, flexible, and powerful programming environment
- Familiar Windows™-based processes simplify entering data
 - “Fill-in-the-Blank” Values “
 - Point and Click” Radio Buttons
 - “Scrolling” Menu Selections
 - “Drag and Drop” parameters and I/O assignments
- Online Watch window for diagnostic, fault, and parameter updates



OR VISIT www.controltechniques.com/download.htm

Expanded Hierarchy View

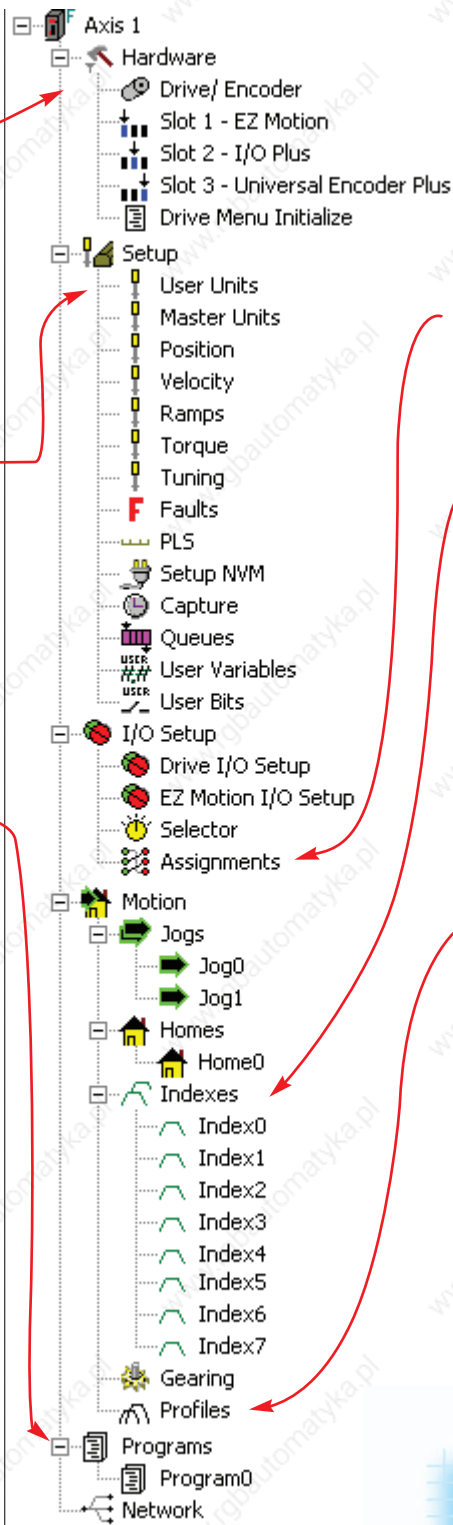

Source	Assigned to	Polarity	Destination	Set From	Polarity
InitiallyActive	PLS.0.PLSEnable	Active On	DriveOutput.1	Index.0.AIVel	Active On
Index	Index.0.AIVel	Active On	Index.0.Initiate	PLS.0.Status	Active On
Cut	Index.0.CommandComplete	Active On	Retract	Index.0.CommandComplete	Active On
PLS	PLS.0.Status	Active On	Home	Home.0.Initiate	Active On
PLS0	PLS.0.Initiate	Active On	Home0	Home.0.SensorTrigger	Active On
Inputs	DriveInput.1	Active On	PLS	PLS.0.PLSEnable	Active On
	DriveInput.2	Active On	Ramps	Stop	Active On
	DriveInput.3	Active On	Master	MasterAxis.DefineHome	Active On

Assignments

Use our "Virtual Wiring" to create programs right out of the box, without writing a "line of code." For example, the assignment screen below shows how easily a flying cutoff routine can be created.

Indexes

Setting up indexes is easily accomplished by filling in the screen's blanks to create an index profile. Select from Incremental, Absolute, Registration, or Rotary Plus and Minus types. Choose the time base of the index by selecting either realtime or synchronised to a master.

Index Number: 0
 Index Name: Index0
 Index Type: Incremental
 Time Base: Realtime

Distance: 50 mm
 Velocity: 2000 mm/m
 Acceleration: 10000 mm/m/s
 Deceleration: 2000 mm/m/s

Enable Index PLS
 PLS On Point: 0.0000 mm
 PLS Off Point: 0.0000 mm

Calculations	Registration	Assignments
Start Position: 0.0000 mm	Peak Velocity Attainable: 2000 mm/m	
Index Distance: 50.0000 mm	Index Time: 2.1000 Seconds	
Accel Distance: 3.3333 mm	Accel Time: 0.2000 Seconds	
At Velocity Distance: 30.0000 mm	At Velocity Time: 0.9000 Seconds	
Decel Distance: 16.6667 mm	Decel Time: 1.0000 Seconds	

Example Index screen

Profiles

This function allows the user to simultaneously execute any two motion types together resulting in a summed profile (i.e. Gear + Index, Jog + Index, Index + Index, etc.). Summing profiles is ideal for phasing applications such as Random Infeed, Rotary Knife, Merge Conveyor, and any number of other applications.

Multiple Profiling

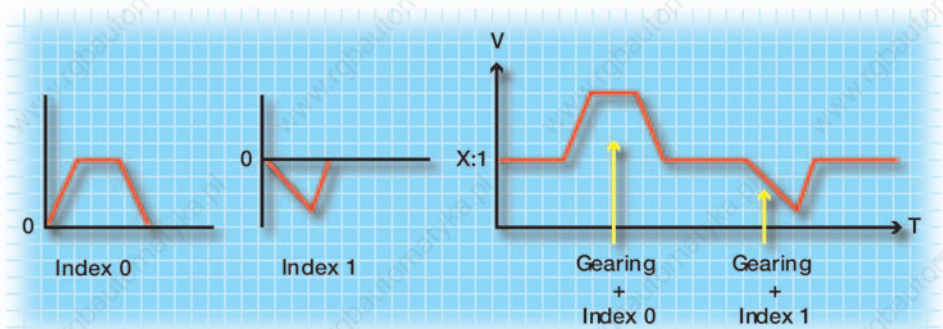

MOTION FUNCTIONALITY WITH UNIDRIVE **SD** AND SyPTPro



Applications with PLC or Motion functionality

SM-Applications Lite **OR** SM-Applications



Programming Platform
SyPTPro (IEC61131-3)

Motion Functionality Features

Embedded Position Loop
Function Block Programming
Ladder Logic Sequencing

OVERVIEW

Unidrive **SD**, the true Solutions Platform, offers a wide range of motion control solutions giving users unparalleled performance and flexibility.

Real cost and space savings are quickly achievable with the flexible modular Unidrive **SD** approach in selecting hardware and IEC61131-3 software.

SAVINGS

- Equipment and machinery manufacturers as well as end-users can achieve lower total component costs using the no-extra-cost onboard Motion functions of the Unidrive **SD**
- In more complex applications the modular hardware approach allows scaling of PLC processing power so that it more precisely matches the demands of the application
- Space Saving – the Motion options for the Unidrive **SD** save space since they are all contained within the drive
- Reduce commissioning time – Unidrive **SD** and its PLC options can be programmed together, using intuitive PLC ladder and function block programming language to IEC61131-3

PERFORMANCE

Unidrive **SD** together with SM-Application or SM-Applications Lite option modules forms a fully digital high performance motion control system:

- 250µs position control loop update
- To maximise performance the position control loop is synchronised accurately to drive speed and current
- Unidrive **SD** may be connected to most encoder feedback devices including high-resolution SinCos encoders. Encoder resolution improves the positioning accuracy and performance of the system
- Additional feedback option modules allow master slave configurations such as electronic gearbox, flying shear or rotary knife. SyPTPro Motion Function blocks allow a range of functions such as relative moves, absolute moves and CAM functionality
- SM-Applications module incorporates CTSync synchronisation for multiple axis control and high speed I/O for time critical field devices

UNIDRIVE **SD** SOLUTIONS PLATFORM

- Global voltage availability, 200-690V, with full range of industrial output ratings – see Unidrive **SD** Servo section
- Universal motor control platform – induction, servo, linear
- Universal feedback with 12 selectable encoder types including:
 - Quadrature, SSI, SinCos, Endat, Hiperface – Integration with your motor feedback virtually guaranteed
- Cost and space saving design features including:
 - RS485 Port, Modbus RTU
 - Secure Disable input as standard to meet EN954-1 cat. 3 a must for modern machine builders
 - Integral EMC filter as standard meets EN61800-3 for global machine conformity
 - Optional zero-space dynamic braking resistors
 - 48-96 VDC operation for low speed set-up/operation or mains supply back-up
 - 24 VDC back up to maintain power for control, fieldbus and encoder for commissioning and monitoring with mains disconnected
- Three option slots supporting a wide range of Solutions Modules for maximum system flexibility.



APPLICATION CO-PROCESSOR MODULES

SM-Applications

The SM-Applications module transforms your Unidrive  drive into a powerful automation controller that adds motion functionality and can be integrated with operator interfaces, remote I/O and other intelligent drives via our drive-to-drive network CTNet. This gives you all of the benefits of a fully distributed control system including better performance, reduced cost and smaller electrical panel sizes.



Performance – The SM-Applications module contains its own high performance micro-processor, leaving the drives own processor to give you the best possible motor performance. It contains 384K of user program memory, meaning that you are never likely to be limited by the program size or processing power of the module.

Easy Powerful Configuration – The “Motion Functionality” is programmed using  (System Programming Tool) allowing you to tackle automation problems from simple start and stop sequencing through to more complex machine and motion control applications. The device is programmed within an IEC61131-3 environment with your choice of 3 languages, meaning that you will be quickly familiar with the  intuitive user interface.  provides a suite of diagnostic and debugging features for maintenance and to help you to get your solution into service faster.

Real-Time Control – SM-Applications gives you real-time access to all of the drives parameters plus access to data from I/O or other drives. The module uses a high-speed multi-tasking operating system with task update times as low as 250µs, fully synchronised to the drives own control kernel to give you the best possible performance for drive control and motion.





SM-Applications I/O – The module has two digital inputs and two digital outputs for high-speed I/O operations such as position capture or actuator firing and a fast optically isolated RS485 port, supporting standard protocols such as; Modbus for connection external devices like Operator Interface panels or synchronous communication using the  protocol.

Standard Solutions – Where applicable standard software Solutions such as winder, flying shear and duty assist are available to help to simplify the development and commissioning process.

SM-Applications Lite







The SM-Applications Lite module is designed to solve your automation requirements where intelligence is needed on a stand-alone drive or a drive connected to a centralised controller connected via I/O or fieldbus.



The Module provides many of the functions of SM-Applications but may be programmed using either  or .  together with SM-Applications Lite gives you an intermediate-level automation solution that is suitable for a wide variety of automation applications, while  and SM-Applications Lite will allow you to exploit the full power and performance of the option module in stand-alone applications.

APPLICATIONS PROGRAMMING SOFTWARE AND

Overview

-  and  software are intuitive PC/Laptop tools for PLC programmers used to working with standard IEC61131-3 programming tools
-  is the entrance level programming tool which is delivered free of charge with the Unidrive  and can be used straight out of the box for programming in quick ladder logic
-  is fully flexible programming tool which is supplied with a users licence for programming in Ladder logic, Function blocks, DPL (Drive Programming Language) script
-  gives the user visibility of the entire system which may include multiple SM-Application modules, I/O modules as well as fieldbus options
- Multiple fieldbus options can be configured to reduce bus traffic via the use of multiple LANS or to allow dynamic bridging from one network to another (e.g. PROFIBUS → DeviceNet)

SyPTPro – System Programming Toolkit

Overview

SyPTPro is the professional drive programming toolkit for OEM's and End Users who wish to maximise the performance of their machines and factory. This IEC61131-3 programming software offers greatly enhanced functionality allowing you to connect drives, Operator Interfaces and I/O to a network and configure how they exchange data. SyPTPro allows you to program in your choice of three different languages, with a real-time multi-tasking environment. It contains a suite of monitoring and diagnostics features that help you to reduce the time it takes to develop your programmes and allows you to get your machine into service faster.

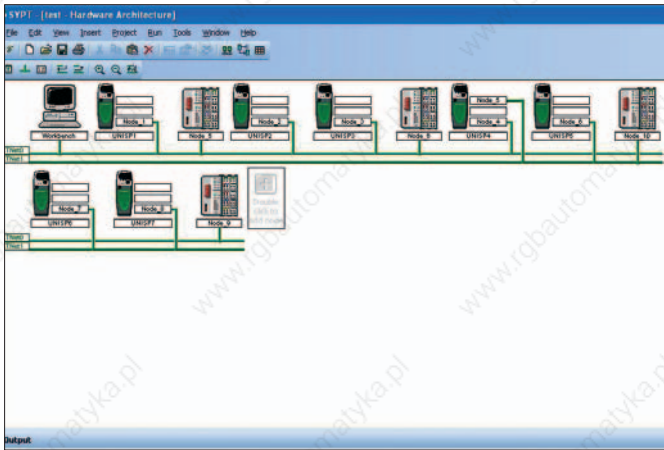

SyPTPro may be used to program Unidrive SD with SM-Applications and SM-Applications Lite Option modules and Mentor II DC Drive with MD29 option modules.

Industrial Network

SyPTPro allows you to configure a single drive or a complete drive system connected to a network. CTNet is an industrial network designed to be deterministic, robust and tolerant to noise and interference. An OPC server is available free of charge from your local Control Techniques Drive Centre or Distributor.

Programming

SyPTPro allows you to program in your choice of three programming languages; these are Function block diagram, Ladder diagram and DPL (Drive Programming Language). And offer a multi-tasking environment where the tasks are scheduled according to the required speed of execution or triggered by events.

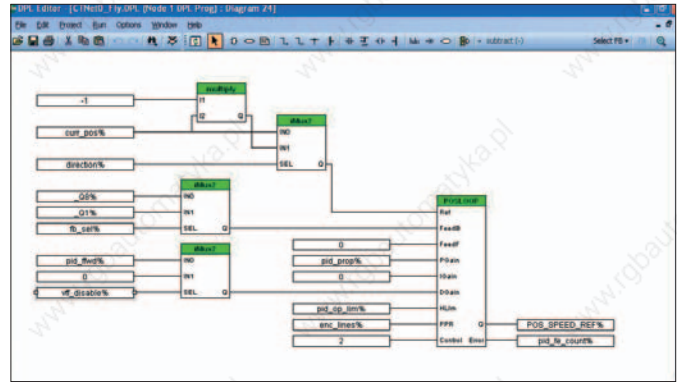

Function Block

SyPTPro incorporates an IEC61131-3 function block diagram editor, and comes with a library of more than 250 function blocks for both simple and complex functions. These embed years of application experience to make your software easier to write and easy to re-use. Additionally you can create a library of your own function blocks or update your library via our online user resources – SyPTPro.com. All function blocks may be used in any of the three languages.

Ladder

SyPTPro incorporates an IEC 61131-3 Ladder language editor. This form of programming will be familiar to all PLC programmers and is the ideal format for sequencing and I/O control.

DPL

Drive Programming Language is a structured text language, as easy to use as BASIC, incorporating many standard constructs, such as IF, THEN, ELSE, and FOR, NEXT loops. DPL is ideal for initialising, configuration and general programming.

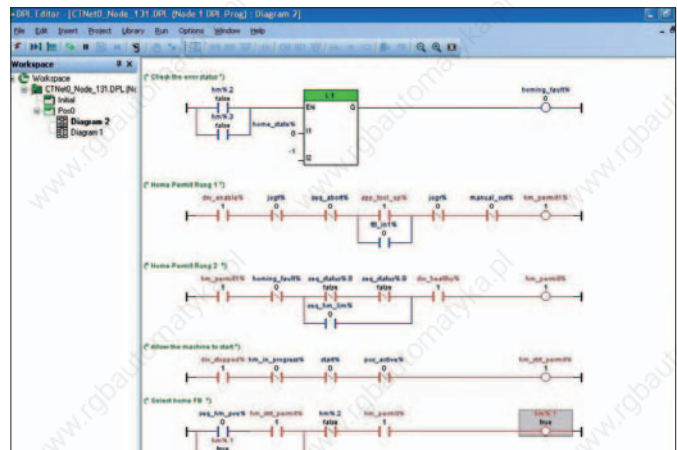

Diagnostics and debugging

Good diagnostics are essential and ensure:

- Software development time is minimised
- Commissioning time is reduced
- Downtime is cut dramatically

SyPTPro contains a suite of diagnostic tools that help you to find problems with the system or software quickly and easily. When connected on-line, **SyPTPro** shows you live real-time views of variables in Function Block Diagrams, Ladder Diagrams and DPL, and allows you to execute program stepping and breakpoints.

System Watch Window

Allows you to monitor real-time variables and parameters from a single drive or multiple drives.

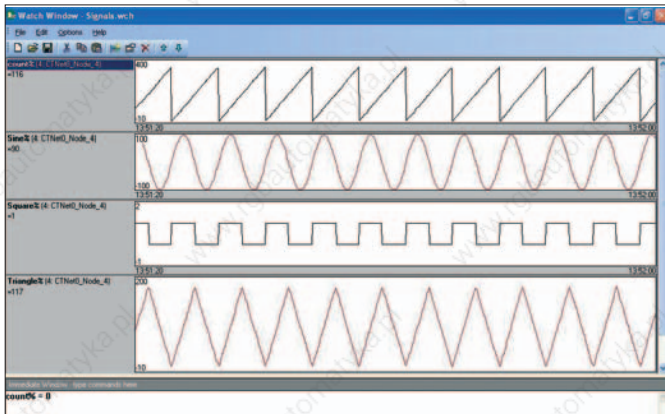

SyPTPro SUPPORT FOR OPEN MOTION PROGRAMMING

PLCopen is a standards organisation that is vendor and product independent, focusing on developing standards for software in industrial automation. The organisation has had major success through the standardisation of PLC programming languages, for example, in the IEC61131-3 specification, which is now widely accepted. PLCopen has now turned its attention to the motion programming and has obtained general agreement on a standard for motion control functions blocks. This has now been implemented in **SyPTPro** for use with the SM-Application programmable modules used with Unidrive **SD**.

Control Techniques has been involved in defining the PLCopen standards for motion control, alongside other major vendors for PLCs and motion controllers, and this is now available as a standard no-cost feature with SM-Applications and **SyPTPro**.

Our motion control environment is designed to make motion control quickly accessible to both novice and experienced users. Our PLCopen function blocks allow you to initialise motion control with a single function block. This will automatically configure the drives parameters ready to accept further commands from the PLCopen motion kernel. Any subsequent function blocks may be used to directly control motion, such as Datum/Home sequences, move relative, move absolute, gearing and cam functionality. This approach provides the simplest method of programming for motion control, and makes it easy to re-use and diagnose your software.

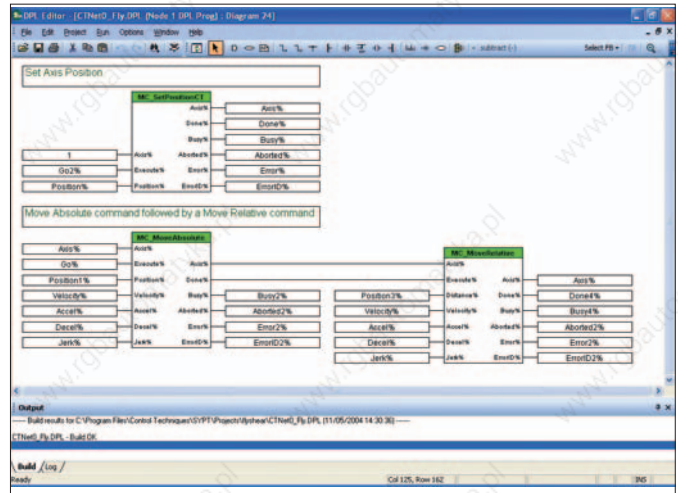

ORDERING

Software (IEC61131-3)	AC Drive** Platform	PLC/Motion Options	PC to Drive Cable
SyPTPro	Unidrive SD	SM-Applications	CT Comms Cable
SyPTLite	Unidrive SD	SM-Applications Lite	CT Comms Cable

See Unidrive **SD Servo selection for further information, or go to www.controltechniques.com

TSYNC

CTSync is a high performance communication link that can improve your machine's performance and reduce the cost of your control system. CTSync is standard with SM-Applications. It provides synchronisation between drive control loops thus allowing the creation of a virtual master reference.

Traditional master / slave synchronisation

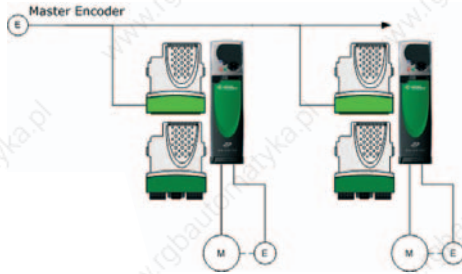

Disadvantages of traditional master/slave:

- High resolution SinCos encoders cannot be multi-dropped
- Difficult connections required for many encoder types, minimum of 6 wires
- Expensive encoder options required on every slave
- Drives software and control loops not synchronised between all drives preventing effective co-ordinated multi axis position control
- Not always possible to connect a master encoder

Using a Virtual Master Reference:

Example: Motion control with 4 axis linear interpolation

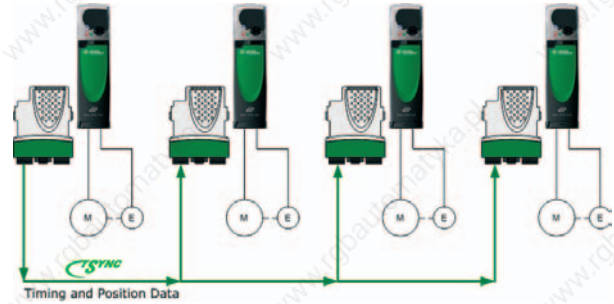

Advantages of 'Virtual Master':

- Co-ordinated multi-axis control with $< 4\mu\text{sec}$ jitter
- Solution for when a real encoder cannot be physically fitted to a machine
- Cleaner noise free signal for guaranteed performance
- Compensation with feed-forward
- Choice of encoder resolution
- Simple 2-wire connection



Motion Functionality Summary with Unidrive

CAM – Application: Any synchronous motion applications, flying shear, rotary knife, etc

- Multiple interpolations between each co-ordinate of the master and slave
 - Linear – Constant velocity
 - Square – Linear ramped velocity
 - Cosine – Sine ramped velocity
 - All the above can be from 0 velocity or an offset velocity
- Single shot or continuous cycling of the CAM modes
- Dynamic change of CAM segment, e.g. start and finish
- Master and Slave co-ordinates are entered as array elements, which can be dynamically changed on the fly or fixed in flash memory

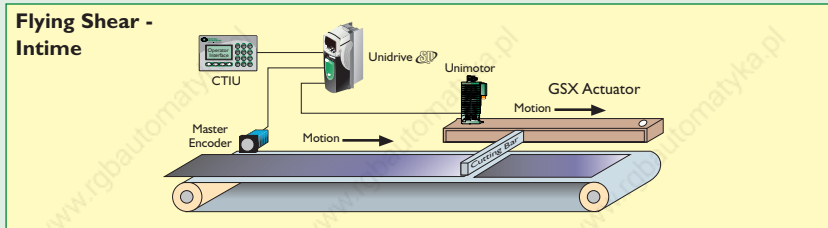
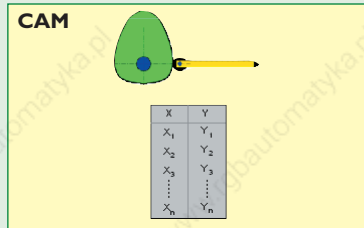

Position Profile Generator – Applications: indexing & point to point

- Linear ramps
- Acceleration, max speed and Jerk parameters can be dynamically changed on the fly

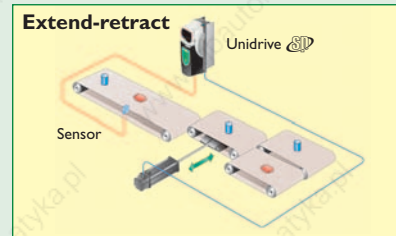
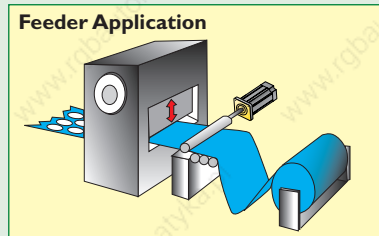
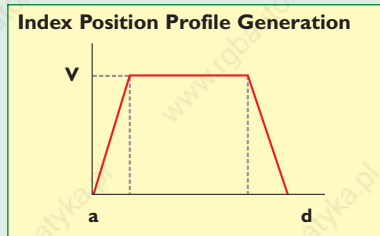

Speed Profile Generator – Applications: jogging, homing

- Linear or 'S' ramps
- Acceleration, max speed and Jerk parameters can be dynamically changed on the fly

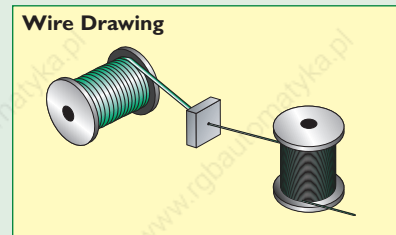
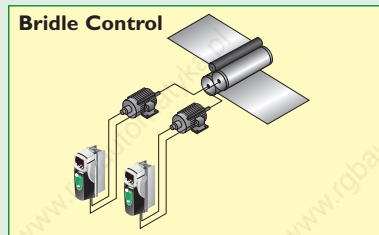
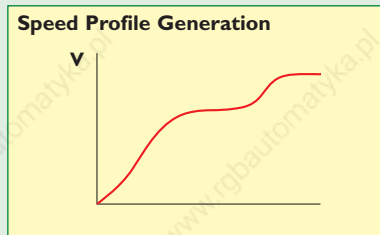

Electronic Gear Box (Digital Lock) – Applications: Master follower applications, conveyors etc

- Wide range of Gear ratios, 32bit integer Numerator/Denominator
- Rigid Lock - ramp to ratio line speed and recover lost position during acceleration, then lock into line position
- Non-Rigid Lock - ramped to ratio line speed and lock into line position
- Lock, No ramps, lock into line position, like a true gearbox

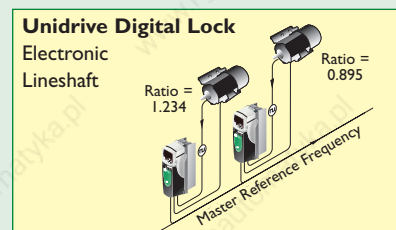
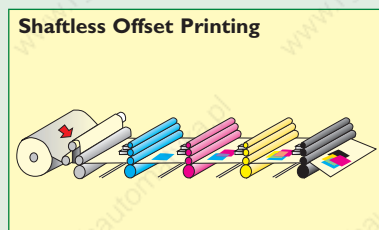
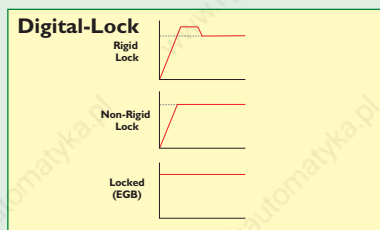

Centralised Motion Control

OVERVIEW

The traditional solution to multi-axis control and complex axis interpolation applications uses Motion Controller, PLC, or PC based centralised approaches. With an efficient one point bridge to the process layer and familiar PLC programming language the complexities of multi axis co-ordination can be catered for using anyone of these three methods to centralised motion control.

The Control Techniques Motion Controller solution is based around the MC Motion Co-ordinator. For PLC based solutions the wide choice of fieldbuses available on Unidrive and Commander SK enables the users to select from virtually every industrial PLC in the marketplace to control their application. For PC based solutions the SLM compatible partners offer as wide selection for users wishing to exploit the performance benefits of SLM technology.

MC MOTION CO-ORDINATORS WITH M'AX, MULTIAX AND UNIMOTOR (SLM)

MC Motion Co-ordinators are fast, powerful and reliable. Easy to install and program, they share a range of common features that ensure maximum system performance with minimal programmer training and simple system upgrades.

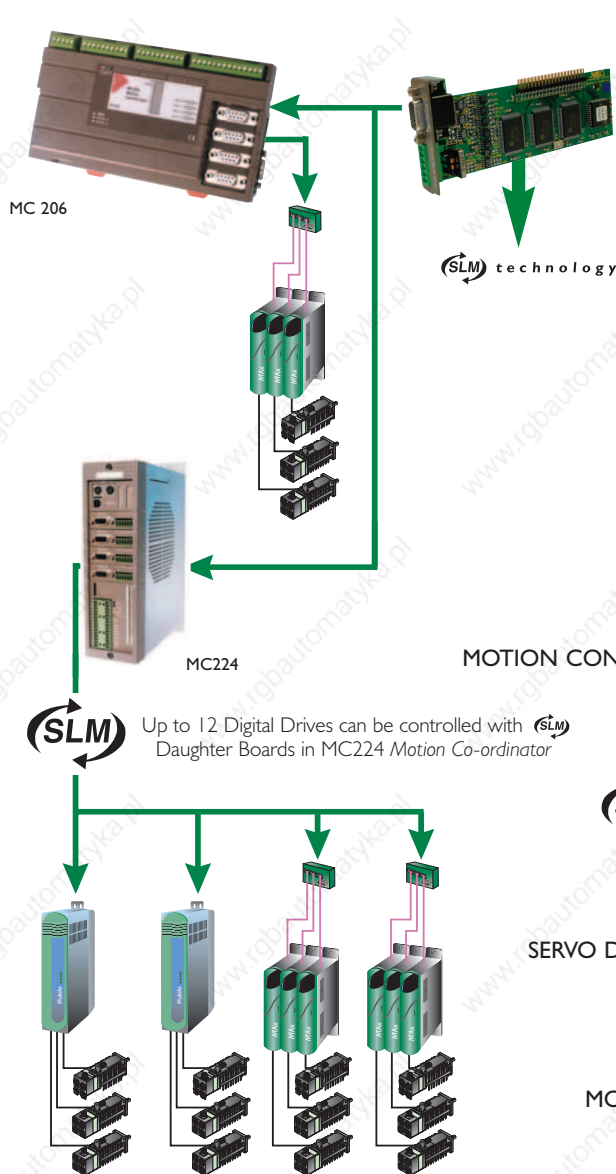

The MC Advantage:

- Choice of 2 Motion Co-ordinators
- Both accept 3 Axis (SLM) Daughter Boards
- Approved for use with M'Ax and MultiAx
- MC 206 + 1 (SLM) D.B.=3 axes
- MC 224 + 4 (SLM) D.B.=12 axes
- Axes not used by (SLM) drives can be used for analog drives and additional communications interfaces

Motion Co-ordinators

- Use Digital Signal Processors
- Allow Servo / Stepper Combinations
- Have accurate, fast Real Number mathematics
- 256 max. Digital I/O expansion channels
- 32 max. Analog Input expansion channels
- Program transfers by a Flash Memory Stick

MOTION CONTROL → MC MOTION CO-ORDINATORS
Pg 176-7

(SLM) → (SLM) TECHNOLOGY
Pg 178-9

SERVO DRIVES → M'AX & MULTIAX
Pg 178-193

MOTORS → UNIMOTOR (SLM)
Pg 186-193

MC 206

DIN rail mounting, 120 MHz DSP, extensive communications options and up to 8 axes of stepper or servo control make this deservedly one of the world's most popular Motion Co-ordinators.

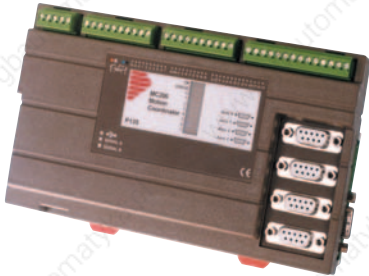

Equipped as standard with a single axis and a reference encoder, the MC206 may be fitted with a MC (SLM) Daughter Board to provide 3 further axes

ideally suited to Control Techniques digital drive systems. For analogue systems, the standard axis provides the necessary $\pm 10V$ speed/torque control signals to the drive.

A further 3 axes may be accessed using MC's unique internet-based Feature Enable Code system, which permits authorised customers to download an access code to provide the exact number of additional axes required for the application.

(SLM) technology

Daughter Board

MC's (SLM) Daughter Board provides the vital link between Motion Co-ordinator and your Control Techniques digital drive.

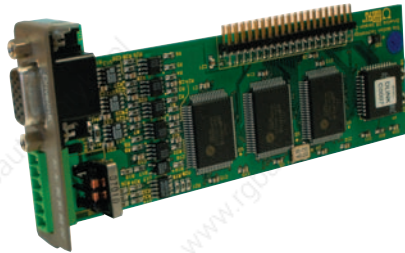

One Daughter Board will control up to 3 axes with each having an independent (SLM) channel to achieve the high speed update of 125 μs . Up to 12 (SLM) – based axes may be used in an MC control system.

MC 224

Up to 12 axes using (SLM) technology 150 MHz DSP and up to 4 Daughter Boards for the ultimate in configuration flexibility with a wide range of communications options.

Axis Expander modules allow up to 4 additional Daughter Boards per module with 4 Axis Expanders per Motion Co-ordinator.



MC Daughter Boards:

P200 - Servo with Encoder	P270 - SSI Absolute Servo
P210 - Servo with Resolver	P280 - Differential Stepper
P220 - Reference Encoder	P290 - 4-axis
P230 - Stepper Output	CAN/CANopen
P240 - Stepper with Encoder	P292 - 3 axis (SLM)
P242 - Hardware PSWITCH	P296 - Ethernet
P260 - Analog Output	P297 - Profibus

Motion Perfect

All MC Motion Co-ordinators are programmed in MC BASIC, a simple language which allows users to achieve remarkable results with minimal training.

Easy to learn, multitasking BASIC produces highly flexible program functionality, often in fewer code lines than many other systems.

By using the same language for all Motion Co-ordinators, we have significantly reduced training times for each new product.

The MC range uses MotionPerfect, an application development environment which employs the Windows graphical user interface to further simplify the programming process.

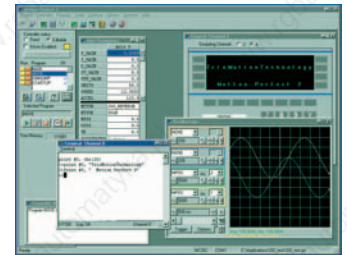

This offers a program editor; an axis tuning page, program tracer; oscilloscope function, and a keypad emulator.

MotionPerfect makes it easy to set-up and commission drive systems by providing an interactive drive set-up wizard.

The program allows fast automatic initialisation and takes full advantage of the plug and play features built in to the M'Ax and MultiAx servo drives.



Additional modules such as CAMGEN, to assist with programming CAM profiles, DocMaker program analyser and report generator; and Cad2Motion, to translate CAD drawings into BASIC programs are also available. MotionPerfect software is supplied for download free of charge from the Control Techniques web site:



MotionPerfect IS SUPPLIED FREE WITH MC RANGE OR VISIT

www.controltechniques.com/download.htm

M'Ax and MultiAx Servo Drives with (SLM) Technology

AC Servo drives 1Nm to 20Nm

OVERVIEW

Historically, advances in servo technology have been incremental steps rather than giant leaps. The M'Ax and MultiAx with (SLM) technology has changed all that. They redefine totally what a user can - and should - expect from a servo system, in terms of installation costs, set-up times, axis performance and dependability. By achieving substantial improvements in all of these crucial areas, both M'Ax and MultiAx provides the machine builder with a simple, powerful and cost effective way of improving the competitiveness and performance of any machine.....

It's an edge that will make all the difference to your machines in ultra competitive global markets.

M'Ax & MultiAx Servo Controller

- Digital clarity with (SLM) (2.5Mbaud, 4 wire system)
- High resolution feedback 8.3M counts per revolution)
- Lower cabling requirements - 4 core (SLM) cable
- Advanced SinCos encoders as standard
- (SLM) Motion Controller compatible
- M'Ax operates also in stand alone mode
- MultiAx is three axis in one servo

(SLM) technology

The (SLM) technology uses a combination of Control Techniques 4-wire, ASIC and motor-mounted SinCos encoders to achieve an application invariant 20-fold increase in position feedback resolution (over 8.3 million points per revolution). This is achieved by integrating speed & position control within the feedback system on-board the servomotor. As a result, the (SLM) is able to overcome the degradation in performance experienced with encoder feedback signals when synchronising multiple servo axes on machines as operating speeds increase.

For the ultimate interpolated multiaxes performance, control loops are deterministic and synchronised to give the lowest jitter in the industry - of 50 nanoseconds. As well as being a performance enhancer now, (SLM) technology is also a gateway to the future. Its integration into PC-based motion systems opens up a whole new vista for optimised multi-axes control in the new future.

(SLM) technology - Your Control Benefits

- Perfect trajectory following - high resolution feedback
- Perfect linearity on velocity feed forward
- Perfect dynamic response on acceleration feed forward
- High control loop bandwidth to achieve sub micron precision on position
- Reduced machine vibration - ultra smooth operation

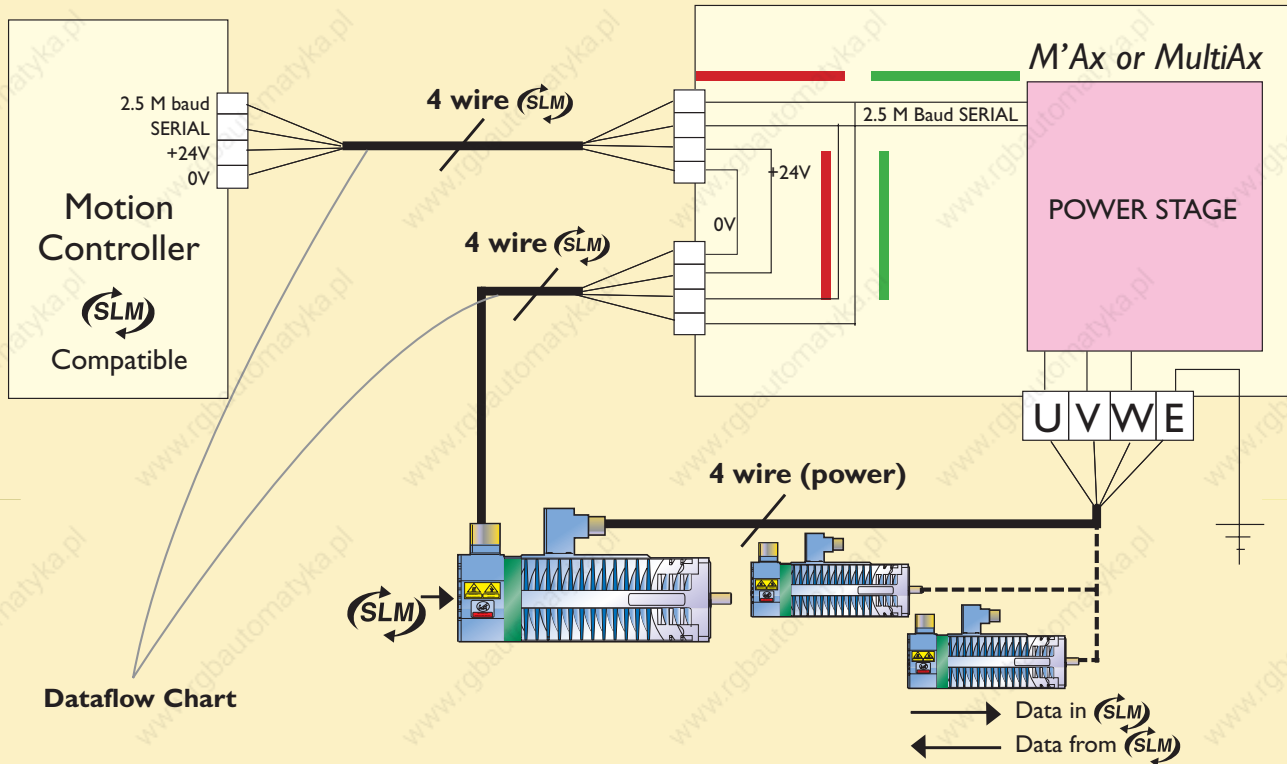

Dataflow Chart

(SLM) Communications Protocol - Fundamental Cycle

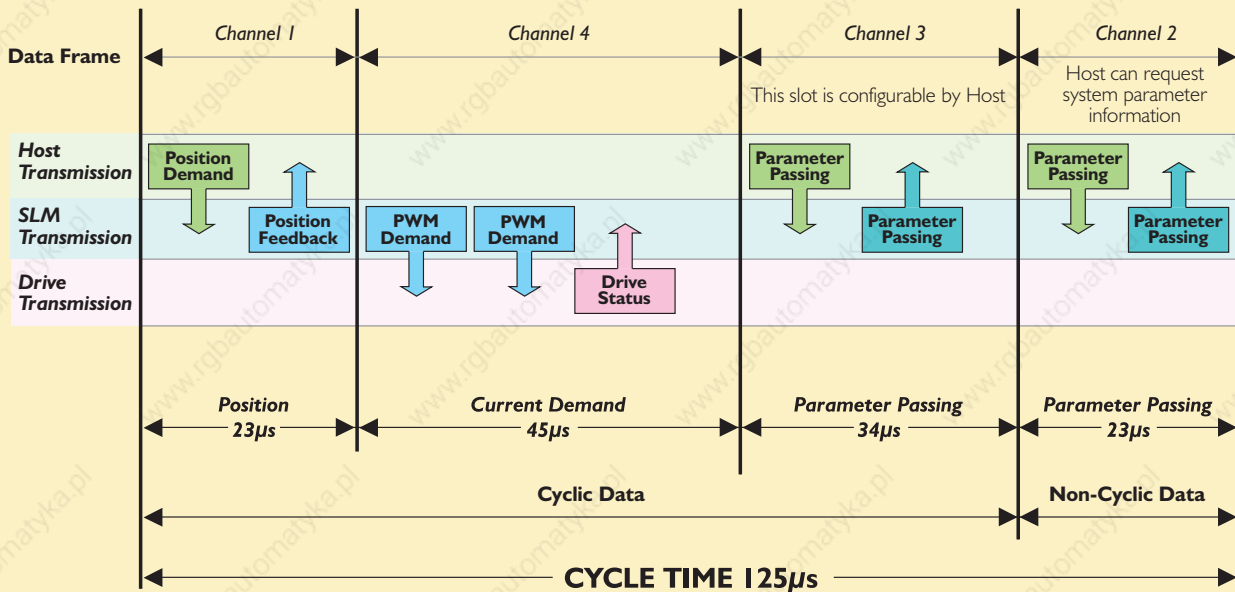

FEATURE PERFORMANCE WITH M'Ax AND MultiAx

Easy Start Up with automatic motor mapping

Easy Start

Automatic Motor Mapping sets itself and gets you going in minutes... No longer do you need to worry about determining and programming the motor type, current, phase angle, inertia, Kt, Ke etc. It is automatic, immediately at power up, even without the need for a PC, thereby ensuring a trouble free and fast start up - Easy Start!

Total System Costs Reduced with M'Ax!

- Reducing wiring in the feedback loop – 4 wire system offers significant advantage over the conventional encoder requiring 14 wires
- Reducing cubicle size – M'Ax is compact, only 62mm wide, the minimum of machinery space required for multi axes installation
- Reducing AC supply connections as M'Ax's can be DC supply fed in parallel connection
- Reducing cabling as motor thermistors are no longer required – M'Ax offers intelligent thermal modelling for accurate and reliable protection of the motor

Highest Resolution Feedback "Perfect" feedback & at an affordable price level!

- Advanced Sin Cos encoders are standard and with **(SLM) technology** the sensitive signals are processed at source to produce the highest resolution in digital form
- Digital clarity is maintained by use of high speed serial link (2.5Mbaud, 4 wire system) to interface between the drive and motor – supports cable runs of up to 50 metres with high level of noise immunity
- M'Ax and MultiAx feedback is "intelligent" and enables vital data flow between the motor, drive and also host motion controller required. For example condition monitoring of motor temperature, performance data and many more control parameters

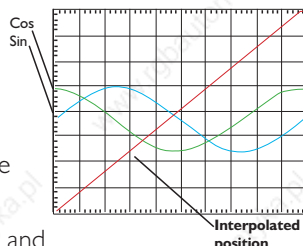

Typical System Material Reductions with MultiAx

- Control wiring terminations down by 45% – increased reliability
- Cubicle wiring down by 60% – your costs reduced
- Cubicle volume cut by over 50% – greater competitiveness
- Total component count reduced by over half – costs down, reliability up

3 Axes (9 amps nominal)	Traditional	MC & MultiAx
Cubicle (see below)		
Plinth		
Isolator		
Fusing	9	3
Line contractor	3	
Safety circuit		
Filter	3	
Drive	3	
24VDC PSU		
MC Motion Controller		
Dynamic Brake resistor	3	
DB Overload	3	
Terminals (approx)	80	20
Motor I15 frame	3	3
Motor power cable 10m	3	3
Motor feedback cable 10m	3	3
Hours build (estimate)	50	18
Wiring points	382	204
Total cost package	100%	70%
Cubicle dimensions mm Height	2000	1200
Width	800	600
Depth	500	500
Cubicle volume	100%	45%

Higher Performance and Precision

Superb precision performance is standard thanks to the revolutionary **(SLM) technology!** M'Ax and MultiAx feedback provides 8.3 million points per revolution for the speed loop control. With this high resolution we are able to track the smallest deviation and work with gains that do not reach the threshold of instability. The result is high dynamic response with good motion regularity and ultra smoothness in rotation.

M'Ax and MultiAx can give your machinery that extra competitive edge through improved machinery performance!

The graphic right shows how **(SLM) technology** makes the difference for a hole cutting machine. In 1 minute – higher productivity, cuts faster, better accuracy and quality (roundness) is up fourfold.

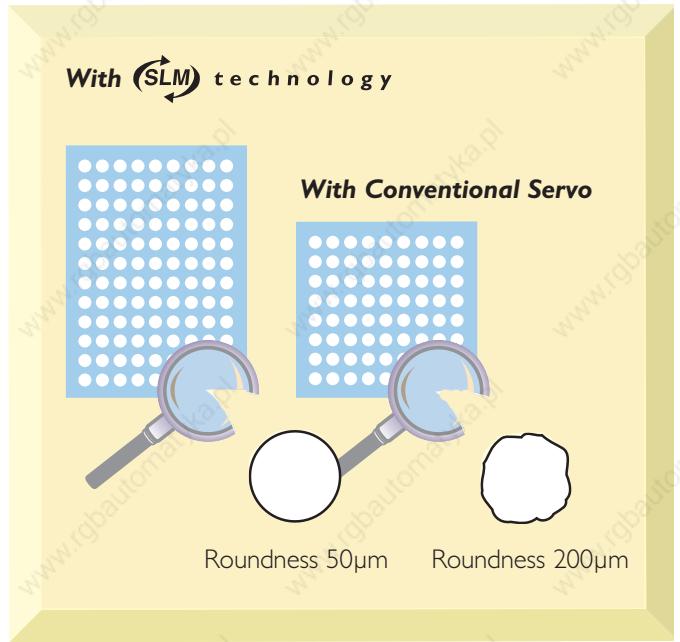

M'Ax RATINGS

Electrical Data												
	Output Current		External RFI Filter (IP20) Complies with EN50081/1 or 2					Internal Braking Resistor				
	Continuous Amps	Peak Current Amps (2sMax)	Part Number	Max Power Dissipation (w)	L (mm)	W (mm)	D (mm)	Value (Ω)	Operating Voltage (V)	Peak Current Amps (A)	Peak Power (kW)	Max.Cont Braking Power (W)
M'Ax 403	3.5	7	4200-1645	6	250	45	70	75	780	10.9	8.9	125
M'Ax 406	6.5	13										
M'Ax 409	9.5	19										
M'Ax 412	12.5	25										

Supply Voltage 380 - 480V ±10% (47.5 to 63Hz)
 Rated ambient 45°C (up to 55°C with derating)
 Altitude: derate above 1000m

Relative humidity: 95% non-condensing

M'Ax TERMINAL DIAGRAM

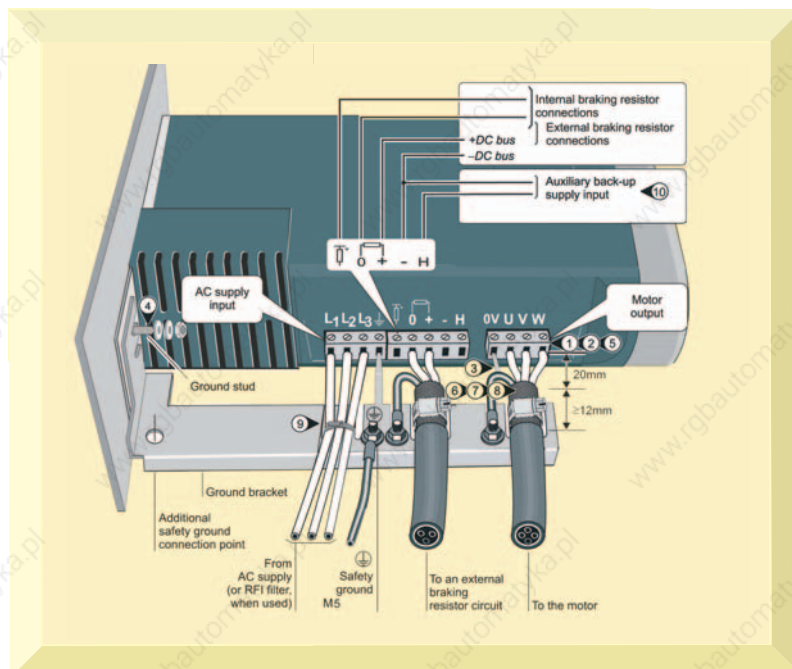

M'Ax TERMINAL DESCRIPTION

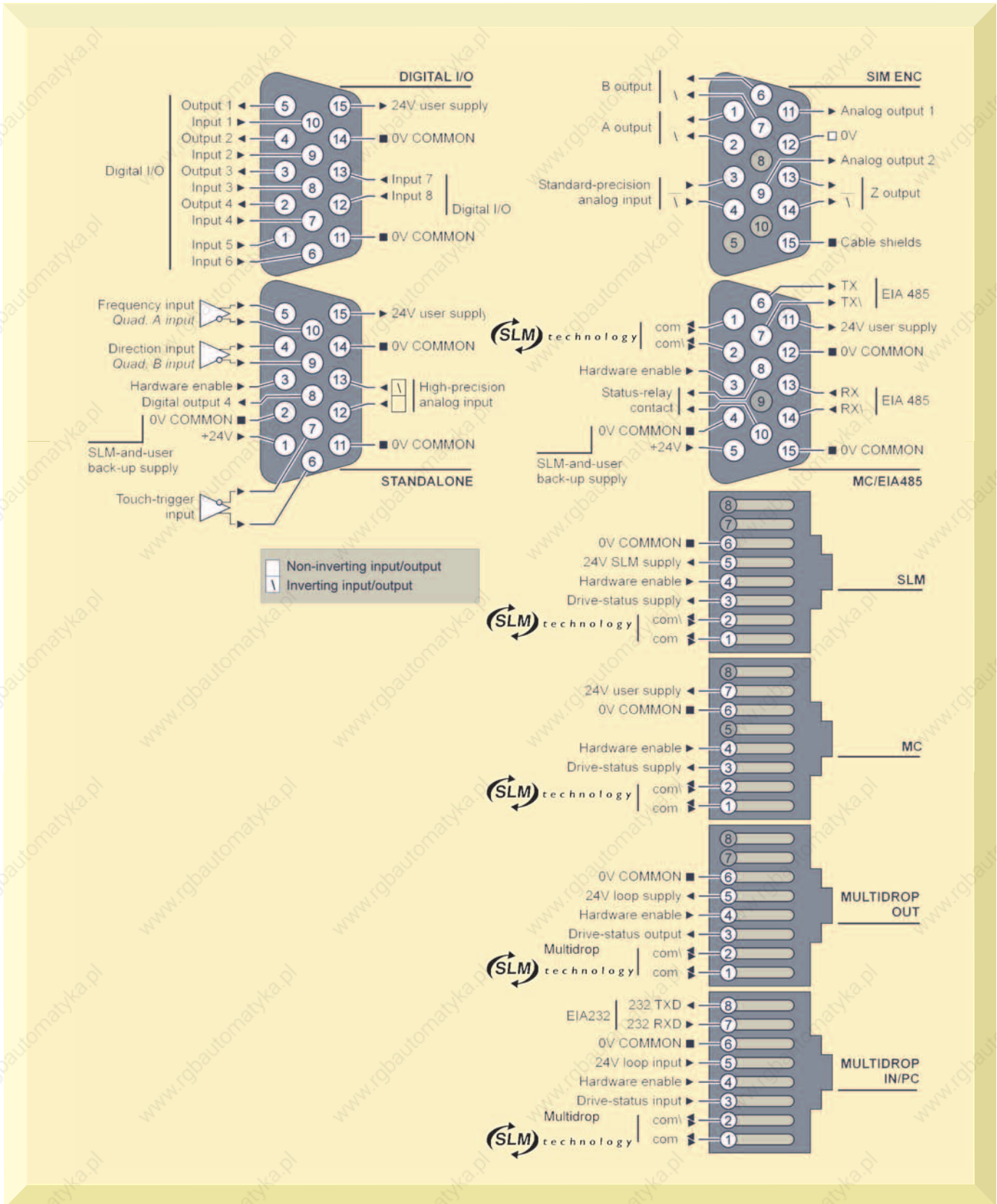

M'Ax SPECIFICATION



Digital I/O

- Opto-isolated
- Eight digital inputs
- Four digital outputs
- 24V user supply

Keypad

- 7 segment removable display
- Memory Pad stores identical set of parameters for easy upload
- 16 bit high precision, $\pm 10V$ differential

Compact Design

- One size for the range 3.5 to 12.5 Amps
- Protection to IP20
- Only 62 mm wide

DC Bus

- Can be supplied from a common DC power supply in parallel with other models
- Reduced DC bus running with drive backup supply

Easy Start

- Automatic motor mapping
- Gains calculator
- MaxSoft with Wizard

'Electronic' Thermistor

- Intelligent thermal modelling
- Accurate monitoring and protection
- Serial data link employed – NO need for thermistor in motor and NO extra cabling requirements

Advanced Feedback

- SinCos encoder as standard
- Reduced cabling 4 wire system – up to 50 metres
- Intelligent capability
- High resolution (8.3 million points per revolution)



Back-up Power Supply

- 24VDC for (SLM) encoder
- 28/32VDC for drive logic suitable for standby, evacuation system - reduced dc bus running

Standalone

- Frequency & direction or quadrature inputs
- 16 bit High precision $\pm 10V$ differential (if keypad fitted)
- (SLM) and user back up supply
- 24V user supply

Simulated Encoder

- Encoder quadrature A, B plus Z marker-pulse outputs (up to 16,384ppr)
- Two analogue outputs
- Standard-precision analogue differential reference input (12 bit)

Communications Port

- RS232 ● RS485 ● ANSI 3.28/Modbus RTU

Braking

- Standard internal resistor 'failsafe' design
- Electronic I²t protection for internal braking resistor
- External resistor connectable



Practical Grounding Bar and Cable Support

- Pluggable terminals for
 - mains supply
 - motor power
 - external braking resistor
- Earthing clamps for motor cable screen

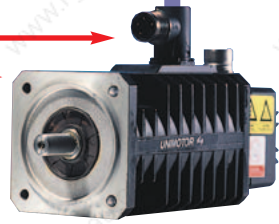

M'Ax Dimensions

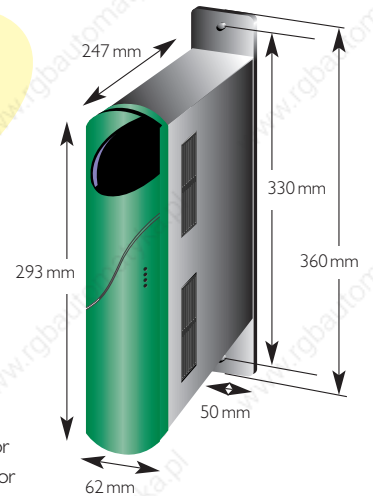

MultiAx RATINGS

Drive	Rating	Output Current						RFI Filter (IP20) Complies with EN50081/I or 2				
		Maximum Continuous Amps			Peak Current (2 sec Max) Amps			Part number	Maximum power dissipation (W)	L mm	W mm	D mm
Axis		A	B	C	A	B	C	4200-3258	11.83	270	50	87
MultiAx SAC/SDC	Low	2.5	2.5	2.5	5.0	5.0	5.0					
MultiAx SAC/SDC	High	9.375	9.375	9.375	18.75	18.75	18.75					
MultiAx HAC/HDC	Low	2.5	2.5	2.5	5.0	5.0	5.0					
MultiAx HAC/HDC	High	15	9.375	9.375	30	18.75	18.75					

AC supply 380 - 480 VAC $\pm 10\%$, 47.5 to 63 Hz
9.75 kW continuous from system

Rated ambient 0 - 50 °C
Altitude: derate above 1000 m
Relative humidity: 95 % non condensing

MultiAx TERMINAL DESCRIPTION

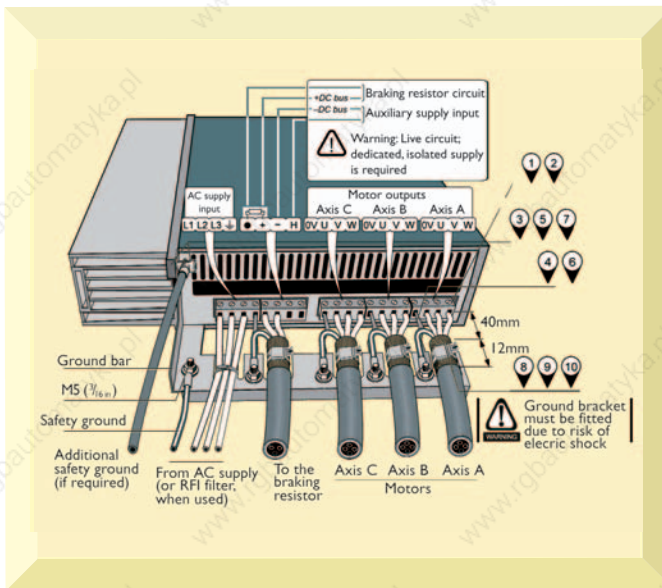

MultiAx TERMINAL DIAGRAM

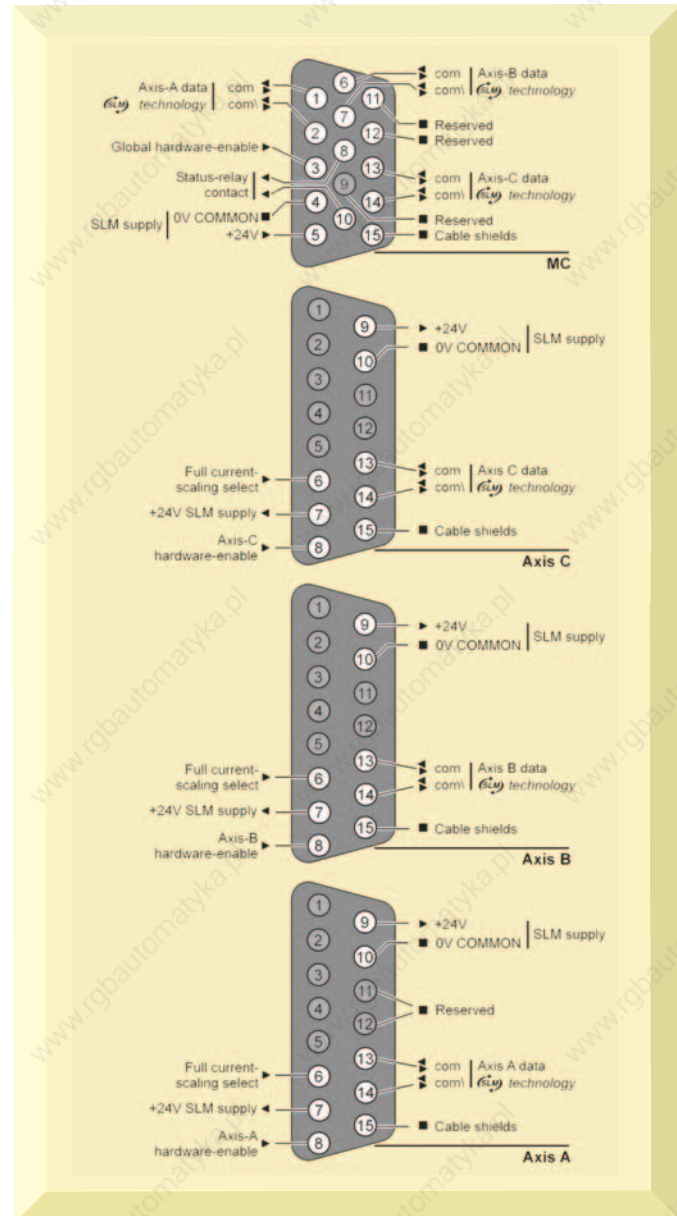

MultiAx SPECIFICATION

MC/ EIA485

- (SLM) technology I/O to the motion controller
- Hardware enable input
- Status relay contact
- (SLM) and user back-up supply
- 24V user supply

Compact Design

- One size for the range
- Protected to IP20
- Only 92 mm for three axes
- Single power input, 3 axes output
- Each axis dual rated

Easy Start

- Automatic motor mapping

Practical Grounding Bar and Cable Support

- Pluggable terminals for - mains supply, motor power, external braking resistor
- Earthing clamps for motor cable screen

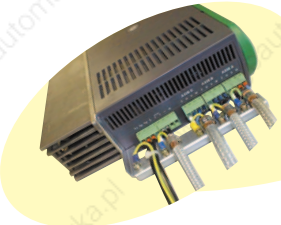

Digital I/O

- 4 Opto Isolated inputs
- 24V User supply

Back-up Power Supply

- 24VDC for (SLM) encoder
- 24-32VDC for drive logic suitable for stand-by

Advanced Feedback

- SinCos encoder
- Reduced cabling
- 4 wire system - up to 50 metre per axis
- Intelligent capacity
- High resolution (8.3 million points per revolution)

Braking

External resistor connectable

DC Bus

- Can be supplied from a common DC power supply in parallel with other models
- Reduced DC bus running with drive back up supply

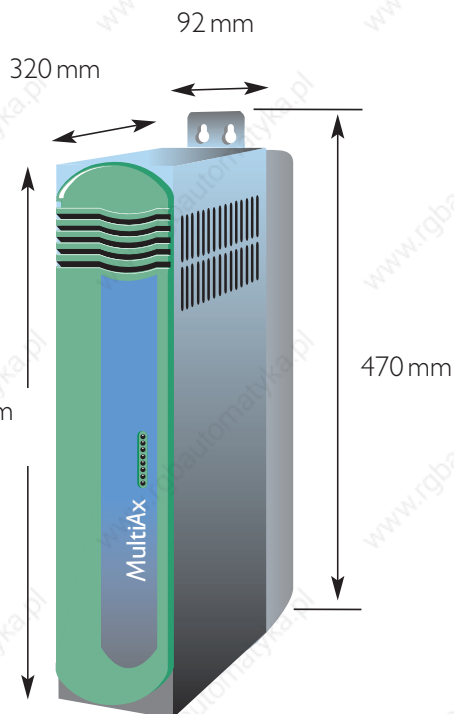

MultiAx DIMENSIONS (MM)

403.8 mm



Unimotor

OVERVIEW

The  version of Unimotor is fitted with special  technology electronic feedback that operates with M'Ax and MultiAx drives. This motor-drive combination offers extremely high resolution, for superb system speed control. High resolution is essential for many system applications where speed and position errors must be miniscule.

The feedback comprises of a special Sincos encoder and electronics, both contained within the standard Unimotor outline. The encoder has a memory programmed with all the essential motor characteristics necessary to automatically set all M'Ax parameters, giving an instant 'Plug and Play' capability.

The Unique 'finned' design improves heat dissipation, and with its single piece design optimises torque output and reduces cogging torque. The compact design gives additional torsional stiffness.

Laminations and coils are optimised to give high efficiency and low harmonic distortion. All this combined with high energy magnets and a choice of rotor inertia, give Unimotor truly dynamic performance to suit all applications.

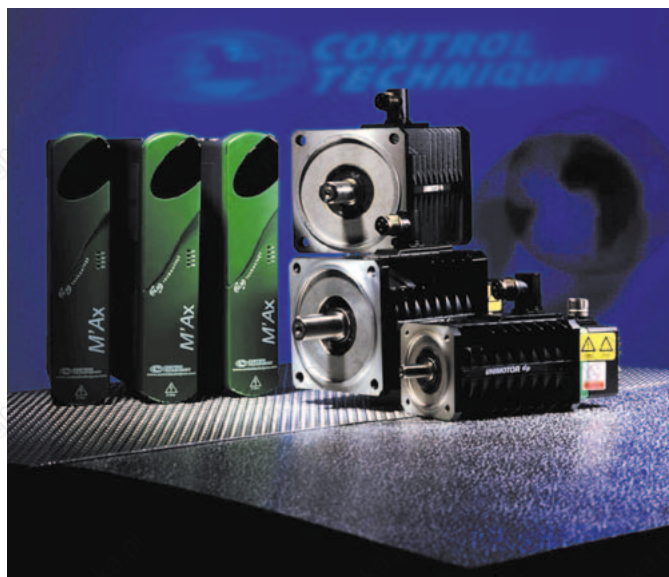

SPECIFICATION

Standard motors have UL and CAN/CSA recognised Insulation System to class. The CTD/IS/2000/01 insulation system number on the motor number plate, together with the symbol, denotes this. Earlier motors may display this information on a separate label on the rear cover:

If the UL symbol has "E215243" underneath, then this indicates full motor recognition.

Machinery Directive 89/392/EEC amended to 98/37/EC

Low Voltage Directive 73/23/EEC

EN 60034	General requirements for rotating electrical machinery
EN 60034-1	Duty: S1 Continuous Storage: -15° to 40°C operating: Min ambient 0°C; max ambient 40°C Less than 1000m altitude Relative humidity: 90% Non condensing
EN 60034-5	Degree of Ingress protection: IP65S (with mating connector & cable fitted)
EN 60034-6	Method of cooling: free circulation, free convection
EN 60034-7	Flange mounted: horizontally or vertically
EN 60034-8	Terminal markings: U V W
EN 60034-11	Thermal protection: PTC thermistor; 165°C TPI 11 (Not SL variants)
EN 60034-18	Insulation system: Class H 600V, UL number E214439
EN 60072	Dimensions and output for rotating electrical machines
EN 60072-1	Type N (Customer variants)
ISO 1940-1	Balancing: to G6.3, (ISO8821 half key convention)

Equipment is not deemed suitable for use in an explosive atmosphere.

This product has been designed to be operated with Control Techniques drives and must not be put into service unless the machinery into which it is to be incorporated has been declared in conformity with the provisions of the machinery directive.

UNIMOTOR (SLM) PERFORMANCE DATA

(SLM) servo motor technical specifications For 3 Phase VPWM Drives 380 - 480Vrms

Motor Frame Size (mm)		75				95					115					142					190
All Speeds	Frame Length	A	B	C	D	A	B	C	D	E	A	B	C	D	E	A	B	C	D	E	A
Unimotors with Encoder Feedback $\Delta t = 100^{\circ}\text{C}$, 40°C ambient		Stall torque; rated torque and power relate to maximum continuous operation in a 40°C ambient All data subject to +/-10% tolerance																			
Continuous Stall Torque (Nm)		1.2	2.2	3.1	3.9	2.3	4.3	5.9	7.5	9.0	3.5	6.6	9.4	12.4	15.3	6.3	10.8	15.3	19.8	23.4	21.8
Peak Torque (Nm)		3.6	6.6	9.3	11.7	6.9	12.9	17.7	22.5	27.0	10.5	19.8	28.2	37.2	45.9	18.9	32.4	45.9	59.4	70.2	65.4
High Inertia (kgcm ²)		1.2	1.6	2.1	2.5	3.5	4.5	5.6	6.7	7.8	9.7	12.0	14.3	16.6	18.8	21.6	28.0	34.3	40.7	47.0	93.5
Standard Inertia (kgcm ²)		0.6	1.0	1.5	1.9	1.4	2.5	3.6	4.7	5.8	3.2	5.5	7.8	10.0	12.3	7.8	14.1	20.5	26.8	33.1	50.0
Weight (kg)		3.0	3.7	4.4	5.1	5.0	6.1	7.2	8.3	9.5	6.5	8.2	9.9	11.6	13.2	10.9	13.2	15.5	17.8	20.5	26.0
Winding Thermal Time Const.(sec)		81	74	94	100	172	168	183	221	228	175	185	198	217	241	213	217	275	301	365	240
Maximum Cogging (Nm)		0.02	0.03	0.04	0.05	0.03	0.06	0.08	0.10	0.13	0.06	0.10	0.14	0.18	0.21	0.09	0.16	0.23	0.30	0.35	0.30
Rated Speed 2000 (rpm)		Kt (Nm/A) 2.40																			
$K_e(NOM) = 147 \text{ V/krpm}$		K_e (V/krpm) 147																			
Rated Torque (Nm)		1.1	2.1	3.0	3.8	2.2	4.0	5.5	6.9	8.2	3.2	6.1	8.7	10.8	14.0	5.9	10.3	14.6	18.4	21.3	20.0
Stall Current (A)		0.5	1.0	1.3	1.7	1.0	1.8	2.5	3.2	3.8	1.5	2.8	4.0	5.2	6.4	2.7	4.5	6.4	8.3	9.8	9.1
Rated Power (kW)		0.23	0.44	0.63	0.80	0.46	0.84	1.15	1.45	1.72	0.67	1.28	1.82	2.26	2.93	1.24	2.16	3.06	3.85	4.46	4.19
R (ph-ph) (Ohms)		144	48.2	25.0	15.7	59.0	17.0	9.90	6.00	4.30	27.8	8.55	4.55	2.96	2.17	12.5	3.60	2.10	1.35	0.98	1.80
L (ph-ph) (mH)		214	99.2	59.2	44.7	131	54.5	36.5	25.6	18.9	94.6	40.5	25.7	18.6	14.7	58.0	29.8	18.7	13.6	10.7	28.1
Rated Speed 3000 (rpm)		Kt (Nm/A) 1.60																			
$K_e(NOM) = 98 \text{ V/krpm}$		K_e (V/krpm) 98.0																			
Rated Torque (Nm)		1.1	2.0	2.8	3.5	2.0	3.9	5.4	6.8	8.1	3.0	5.5	8.1	10.4	12.6	5.4	9.0	12.2	15.8	18.0	19.2
Stall Current (A)		0.8	1.4	2.0	2.5	1.5	2.7	3.7	4.7	5.7	2.2	4.2	5.9	7.8	9.6	4.0	6.8	9.6	12.4	14.7	13.7
Rated Power (kW)		0.35	0.63	0.88	1.10	0.63	1.23	1.70	2.14	2.54	0.94	1.73	2.54	3.27	3.96	1.70	2.83	3.83	4.96	5.65	6.03
R (ph-ph) (Ohms)		60.8	20.1	10.5	7.5	24.5	6.80	4.00	2.50	2.00	12.6	3.86	2.02	1.40	1.10	5.63	1.72	0.94	0.61	0.44	0.79
L (ph-ph) (mH)		98.4	41.8	27.6	19.7	57.9	24.3	15.5	10.9	8.50	43.1	18.6	11.4	8.60	7.40	31.0	13.3	8.30	6.10	4.80	13.2
Rated Speed 4000 (rpm)		Kt (Nm/A) 1.20																			
$K_e(NOM) = 73.5 \text{ V/krpm}$		K_e (V/krpm) 73.5																			
Rated Torque (Nm)		1.0	1.7	2.3	2.9	1.8	3.0	4.0	4.9	5.7	2.5	4.7	6.3	7.5	8.7	3.6	7.0	8.9	10.7	12.2	▲
Stall Current (A)		1.0	1.9	2.6	3.3	2.0	3.6	5.0	6.3	7.5	3.0	5.5	7.9	10.4	12.8	5.3	9.0	12.8	16.5	19.5	▲
Rated Power (kW)		0.42	0.71	0.96	1.21	0.75	1.26	1.68	2.05	2.39	1.05	1.97	2.64	3.14	3.64	1.51	2.93	3.73	4.48	5.11	▲
R (ph-ph) (Ohms)		36.8	10.5	6.30	4.20	12.7	4.08	2.10	1.50	1.03	6.91	2.14	1.16	0.73	0.57	3.12	1.00	0.53	0.35	0.24	▲
L (ph-ph) (mH)		54.9	24.8	14.9	10.8	31.5	13.6	8.50	6.30	4.80	23.5	10.2	6.60	4.70	3.90	17.6	7.50	4.70	3.60	2.70	▲
Rated Speed 6000 (rpm)		Kt (Nm/A) 0.80																			
$K_e(NOM) = 49.0 \text{ V/krpm}$		K_e (V/krpm) 49.0																			
Rated Torque (Nm)		0.9	1.6	2.1	2.6	1.3	2.1	2.8	3.3	3.7	2.2	4.0	5.1	▲	N/A	2.9	4.5	▲	▲	N/A	▲
Stall Current (A)		1.5	2.8	3.9	4.9	2.9	5.4	7.4	9.4	11.3	4.4	8.3	11.8			7.9	13.5	▲	▲	N/A	▲
Rated Power (kW)		0.57	1.01	1.32	1.63	0.82	1.32	1.76	2.07	2.32	1.38	2.51	3.20			1.82	2.83	▲	▲	N/A	▲
R (ph-ph) (Ohms)		15.0	5.00	2.66	1.90	5.45	1.82	1.05	0.62	0.48	3.1	0.97	0.50			1.42	0.46	▲	▲	N/A	▲
L (ph-ph) (mH)		24.0	10.6	6.80	4.80	14.1	6.00	3.80	2.70	2.10	15.54	4.81	2.94			7.72	3.44	▲	▲	N/A	▲

N/A Not Available

▲ Consult factory

The information contained in this specification is for guidance only and does not form part of any contract
CT Dynamics Limited have an ongoing process of development and reserve the right to change the specification without notice.

UNIMOTOR (SLM) DIMENSIONS (MM)

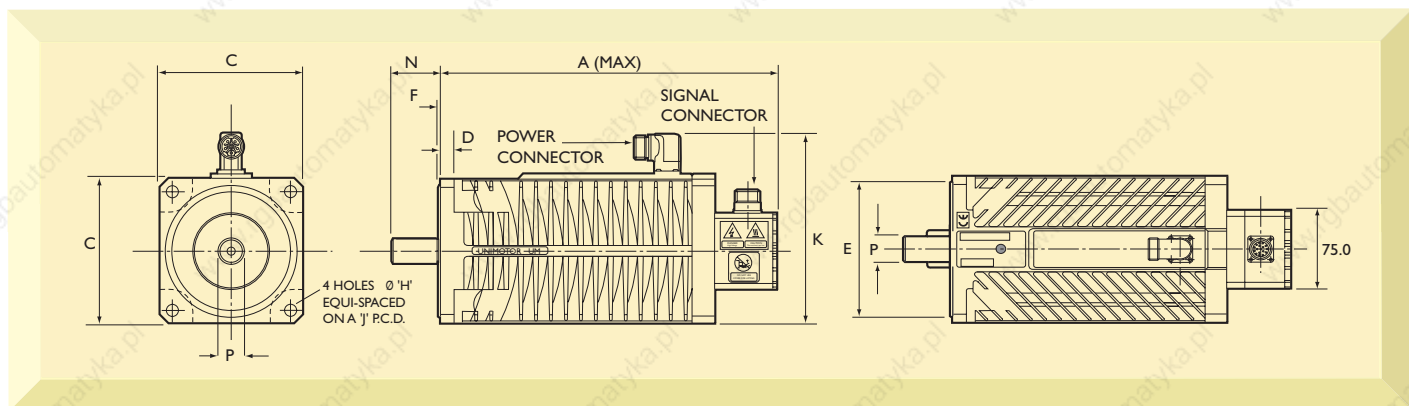

Ref	Description	75A	75B	75C	75D	95A	95B	95C	95D	95E	115A	115B	115C	115D	115E	142A	142B	142C	142D	142E	190A
A	Length overall (unbraked)	211	241	271	301	222	252	282	312	342	242	272	302	332	362	225	255	285	315	345	273
A	Length overall (braked)	241	271	301	331	252	282	312	342	372	272	302	332	362	392	285	315	345	375	405	327
C	Flange Square	75	75	75	75	95	95	95	95	95	115	115	115	115	115	142	142	142	142	142	190
D	Flange Thickness	7	7	7	7	9	9	9	9	9	11	11	11	11	11	12.3	12.3	12.3	12.3	12.3	14.5
E	Register Diameter (J6)	60	60	60	60	80	80	80	80	80	95	95	95	95	95	130	130	130	130	130	180
F	Register Length	2.4	2.4	2.4	2.4	2.9	2.9	2.9	2.9	2.9	2.9	2.9	2.9	2.9	2.9	3.4	3.4	3.4	3.4	3.4	4.0
H	Fixing Holes Diameter (H14)	5.8	5.8	5.8	5.8	7	7	7	7	7	10	10	10	10	10	12	12	12	12	12	14.5
J	Fixing Hole p.c.d	75	75	7.5	75	100	100	100	100	100	115	115	115	115	115	165	165	165	165	165	215
K	Overall Height	126	126	126	126	146	146	146	146	146	166	166	166	166	166	193	193	193	193	193	256
N	Shaft Length (front)	23	30	30	30	30	40	40	40	40	40	40	40	50	50	50	50	50	50	50	58
P	Shaft Diameter (front)	11	14	14	14	14	19	19	19	19	19	19	19	24	24	24	24	24	24	24	32

M'Ax and UNIMOTOR (SLM) SELECTION

Reference No.	Motor Type (#) 3000rpm Kt (1.6Nm/A rms)	Drive Type	Stall Torque (Nm)	Stall Current (Arms)	Peak Torque (Nm)	Torque @ 3000rpm (Nm)	Standard Inertia(*) (kgcm ²)	Motor Weight (kg)
1	75SLA300CBPAA	M'Ax 403	1.2	0.8	3.6	1.1	0.6	3.5
2	75SLB300CBPAA	M'Ax 403	2.2	1.4	6.3	2.0	1.0	4.3
3	75SLC300CBPAA	M'Ax 403	3.1	2.0	8.4	2.8	1.5	5.1
4	75SLD300CBPAA	M'Ax 403	3.9	2.5	10.8	3.5	1.9	5.8
5	95SLA300CBPAA	M'Ax 403	2.3	1.5	6.9	2.0	1.4	4.7
6	95SLB300CBPAA	M'Ax 403	4.3	2.7	11.2 (t)	3.9	2.5	6.1
7	95SLC300CBPAA	M'Ax 406	5.9	3.7	17.77 (t)	5.4	3.6	7.3
8	95SLD300CBPAA	M'Ax 406	7.5	4.7	20.7	6.8	4.7	8.8
9	95SLE300CBPAA	M'Ax 406	9.0	5.7	20.8 (t)	8.1	5.8	10.4
10	115SLA300CBPAA	M'Ax 403	3.5	2.2	11.2 (t)	3.0	3.2	7.3
11	115SLB300CBPAA	M'Ax 406	6.6	4.2	19.8	5.5	5.5	8.8
12	115SLC300CBPAA	M'Ax 406	9.4	5.9	20.8 (t)	8.1	7.8	10.6
13	115SLD300CBPAA	M'Ax 409	12.4	7.8	30.4 (t)	10.4	10.0	12.5
14	115SLE300CBPAA	M'Ax 412	15.3	9.6	40.4 (t)	12.6	12.3	14.2
15	142SLA300CBPAA	M'Ax 406	6.3	4.0	18.9	5.4	7.8	9.4
16	142SLB300CBPAA	M'Ax 409	10.8	6.8	30.4 (t)	9.0	14.1	12.1
17	142SLC300CBPAA	M'Ax 412	15.3	9.6	40.0	12.2	20.5	14.7
18	142SLD300CBPAA	M'Ax 412	19.8	12.4	40.0	15.8	26.8	17.6

Preferred stocking frames are B and D. For other combinations - consult Drive Centre.

(#): Motors in table are connectorised, no brake, no key - plain shaft, IEC flange, standard inertia.

Other base speeds are 2000rpm (2.4Nm/A rms), 4000rpm (1.2Nm/A rms); 6000rpm also available

Options available: Brake, cable assemblies, planetary gearboxes, keyed shaft

(t): Motor is capable of higher peak torques when used with next higher rating M'Ax.

(*): Higher inertia rotors are available as options.

M'Ax and UNIMOTOR (SLM) SPEED TORQUE CURVES

(2) 75SLB300 with M'Ax 403

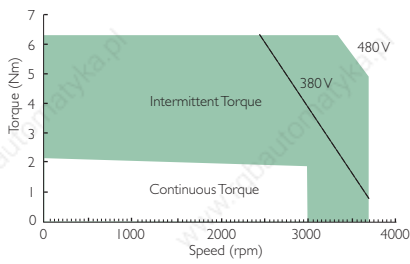

(3) 75SLC300 with M'Ax 403

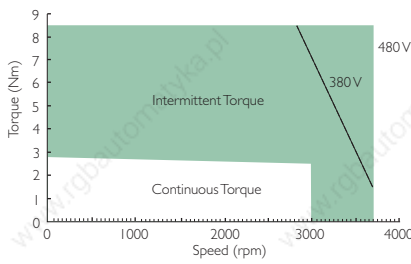

(4) 75SLD300 with M'Ax 403

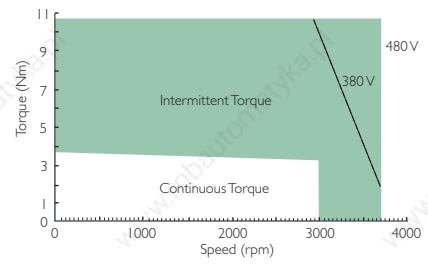

(5) 95SLA300 with M'Ax 403

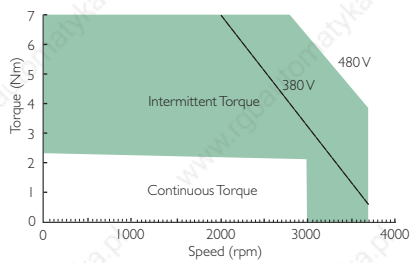

(6) 95SLB300 with M'Ax 403

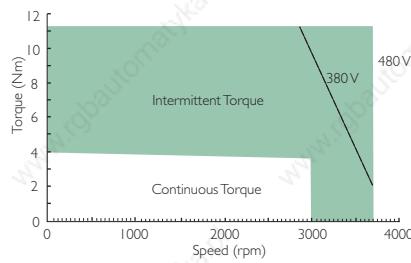

(7) 95SLC300 with M'Ax 403

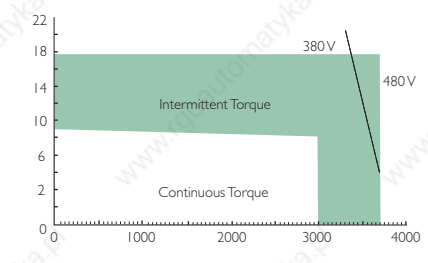

(8) 95SLD300 with M'Ax 406

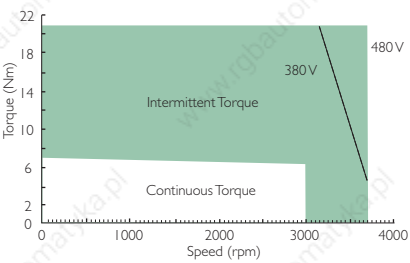

(9) 95SLE300 with M'Ax 406

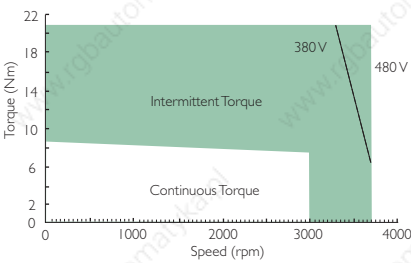

(11) 115SLB300 with M'Ax 406

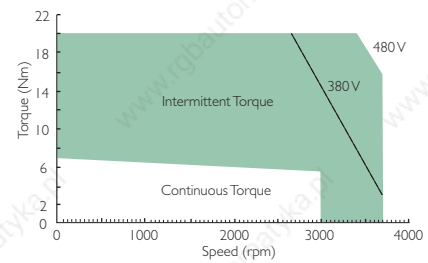

(12) 115SLC300 with M'Ax 406

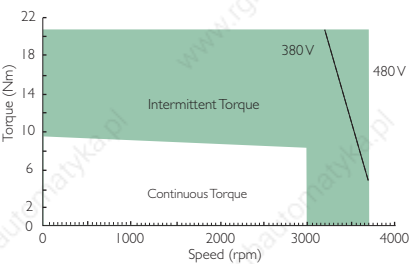

(13) 115SLD300 with M'Ax 409

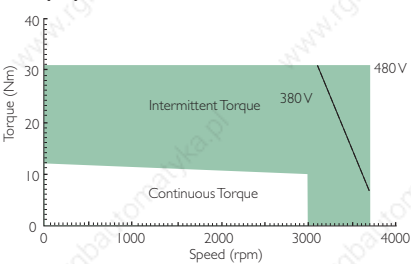

(14) 115SLE300 with M'Ax 409

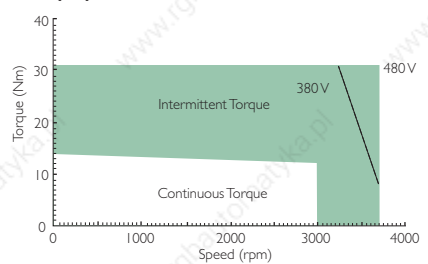

(16) 142SLB300 with M'Ax 409

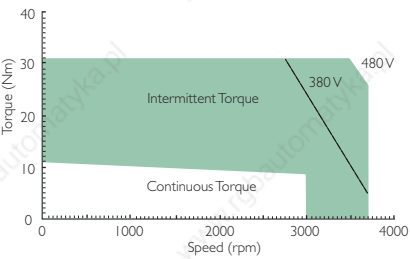

(17) 142SLC300 with M'Ax 412

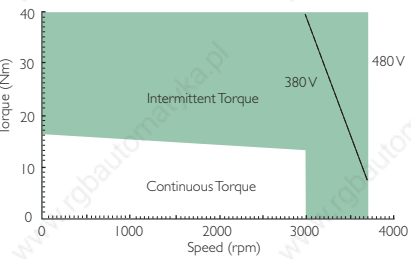

(18) 142SLD300 with M'Ax 412

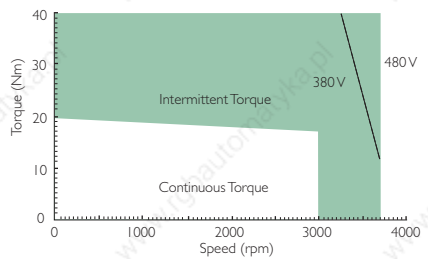

40°C Ambient, up to $\Delta t 100$; 10% tolerance on all performance data

MultiAx and UNIMOTOR (SLM) SELECTION

Reference No.	Motor Type (#) 3000rpm Kt (1.6Nm/A rms)	MultiAx Type	Stall Torque (Nm)	Stall Current (Arms)	Peak Torque (Nm)	Torque @ 3000rpm (Nm)	Standard Inertia(*) (kgcm ²)	Motor Weight (kg)
1	75SLA300CBPAA	MultiAx SAC	1.2	0.8	3.6	1.1	0.6	3
2	75SLB300CBPAA	MultiAx SAC	2.2	1.4	6.3	1.9	1.0	3.7
3	75SLC300CBPAA	MultiAx SAC	3.1	2.0	9.3	2.5	1.5	4.4
4	75SLD300CBPAA	MultiAx SAC	3.9	2.5	11.7	3.3	1.9	5.1
5	95SLA300CBPAA	MultiAx SAC	2.3	1.5	6.9	2.1	1.4	5.0
6	95SLB300CBPAA	MultiAx SAC	4.3	2.7	12.9	3.6	2.5	6.1
7	95SLC300CBPAA	MultiAx SAC	5.9	3.7	16.5	5.0	3.6	7.2
8	95SLD300CBPAA	MultiAx SAC	7.5	4.7	20.7	6.3	4.7	8.3
9	95SLE300CBPAA	MultiAx SAC	9.0	5.7	25.2	7.6	5.8	9.5
10	115SLA300CBPAA	MultiAx SAC	3.5	2.2	8.0	3.3	3.2	6.5
11	115SLB300CBPAA	MultiAx SAC	6.6	4.2	19.8	5.5	5.5	8.2
12	115SLC300CBPAA	MultiAx SAC	9.4	5.9	28.5	7.7	7.8	9.9
13	115SLD300CBPAA	MultiAx SAC	12.4	7.8	30.0	9.7	10.0	11.6
14	115SLE300CBPAA	MultiAx HAC	15.3	9.6	45.9	11.4	12.3	13.2
15	142SLA300CBPAA	MultiAx SAC	6.3	4.0	18.9	5.4	7.8	10.9
16	142SLB300CBPAA	MultiAx SAC	10.8	6.8	30.0	9.0	14.1	13.2
17	142SLC300CBPAA	MultiAx HAC	15.3	9.6	45.9	12.2	20.5	15.5
18	142SLD300CBPAA	MultiAx HAC	19.8	12.4	48.0	15.8	26.8	17.8
19	142SLE300CBPAA	MultiAx HAC	23.4	14.7	48.0	18.0	33.1	20.5
20	190SLA300CBPAA	MultiAx HAC	21.8	13.7	48.0	19.2	50.0	26.0

Preferred stocking frames are B and D. For other combinations - consult Drive Centre.
 (#): Motors in table are connectorised, no brake, no key - plain shaft, IEC flange, standard inertia.
 Other base speeds are 2000rpm (2.4Nm/A rms), 4000rpm (1.2Nm/A rms); 6000rpm also available
 Options available: Brake, cable assemblies, planetary gearboxes, keyed shaft
 (*): Higher inertia rotors are available as options.

MultiAx and UNIMOTOR (SLM) SPEED TORQUE CURVES

(2) 75SLB300 with MultiAx SAC

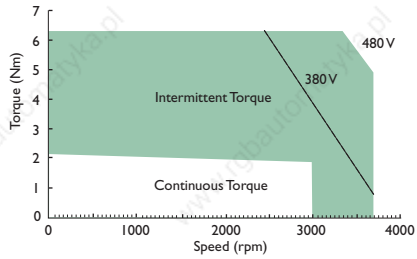

(3) 75SLC300 with MultiAx SAC

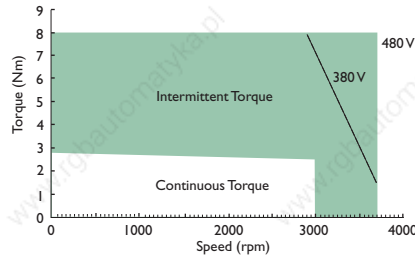

(4) 75SLD300 with MultiAx SAC

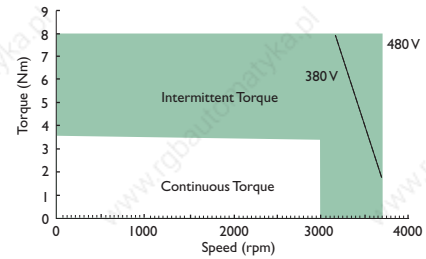

(6) 95SLB300 with MultiAx SAC

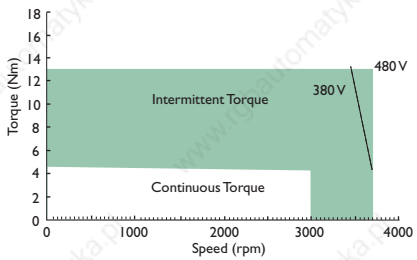

(7) 95SLC300 with MultiAx SAC

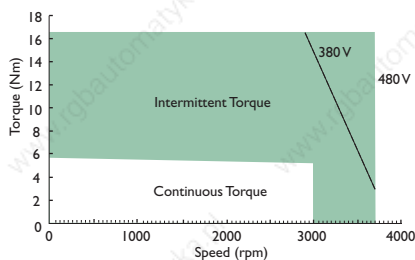

(8) 95SLD300 with MultiAx SAC

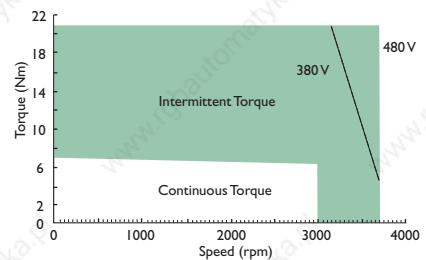

(9) 95SLE300 with MultiAx SAC

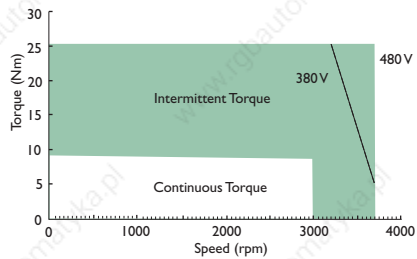

(11) 115SLB300 with MultiAx SAC

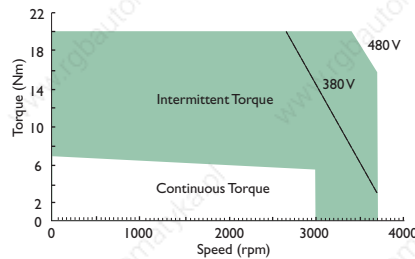

(12) 115SLC300 with MultiAx SAC

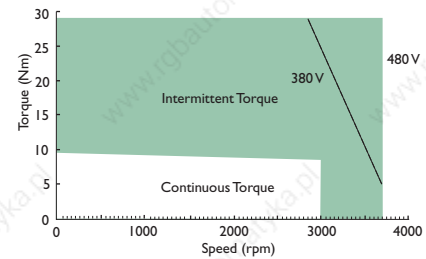

(13) 115SLD300 with MultiAx SAC

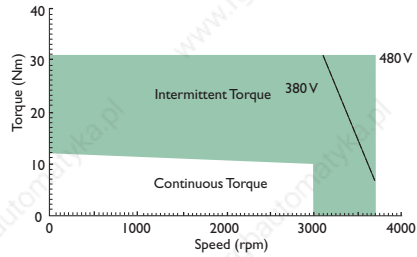

(16) 142SLB300 with MultiAx SAC

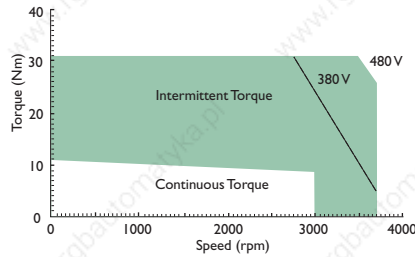

(17) 142SLC300 with MultiAx HAC

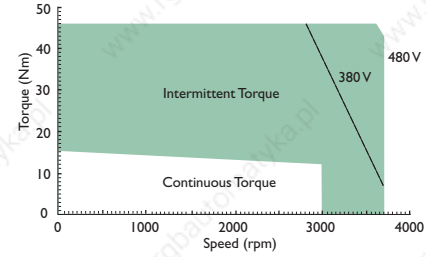

(18) 142SLD300 with MultiAx HAC

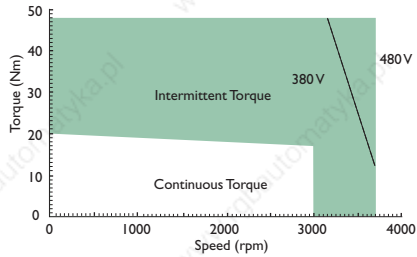

(19) 142SLE300 with MultiAx HAC

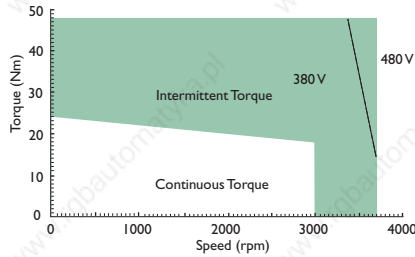

(20) 190SLA300 with MultiAx HAC

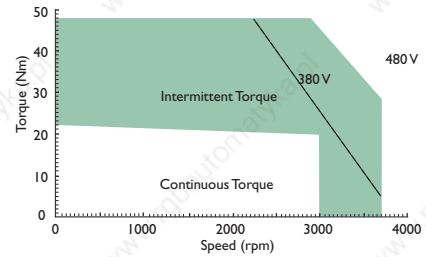

40°C Ambient, up to $\Delta t 100$; 10% tolerance on all performance data

Unimotor (SLM) Power Cable selection

Cable type – PS for motor without brakes, PB for motors with brake.

Jacket – B is for a PUR sheath and is the standard selection. A is for a PVC sheath to be used on the DS brake cable only.

Conductor Size – Select the conductor size according to the motors STALL CURRENT.

Include forced cooling performance if applicable.

Cables of 6mm² and above will be fitted with ring terminals only.

Ratings are for individual cables (not lashed together) in free air temperature up to 40°C - make allowances as appropriate.

Connection detail drive end – Select the correct drive end connection for the drive in use.

Connection detail motor end – Select the correct motor end connection for the motor in use.

Length – Numbers represent the required cable length in metres. Conversion cables will be limited to 0.4m only and the length is not required in the order code.

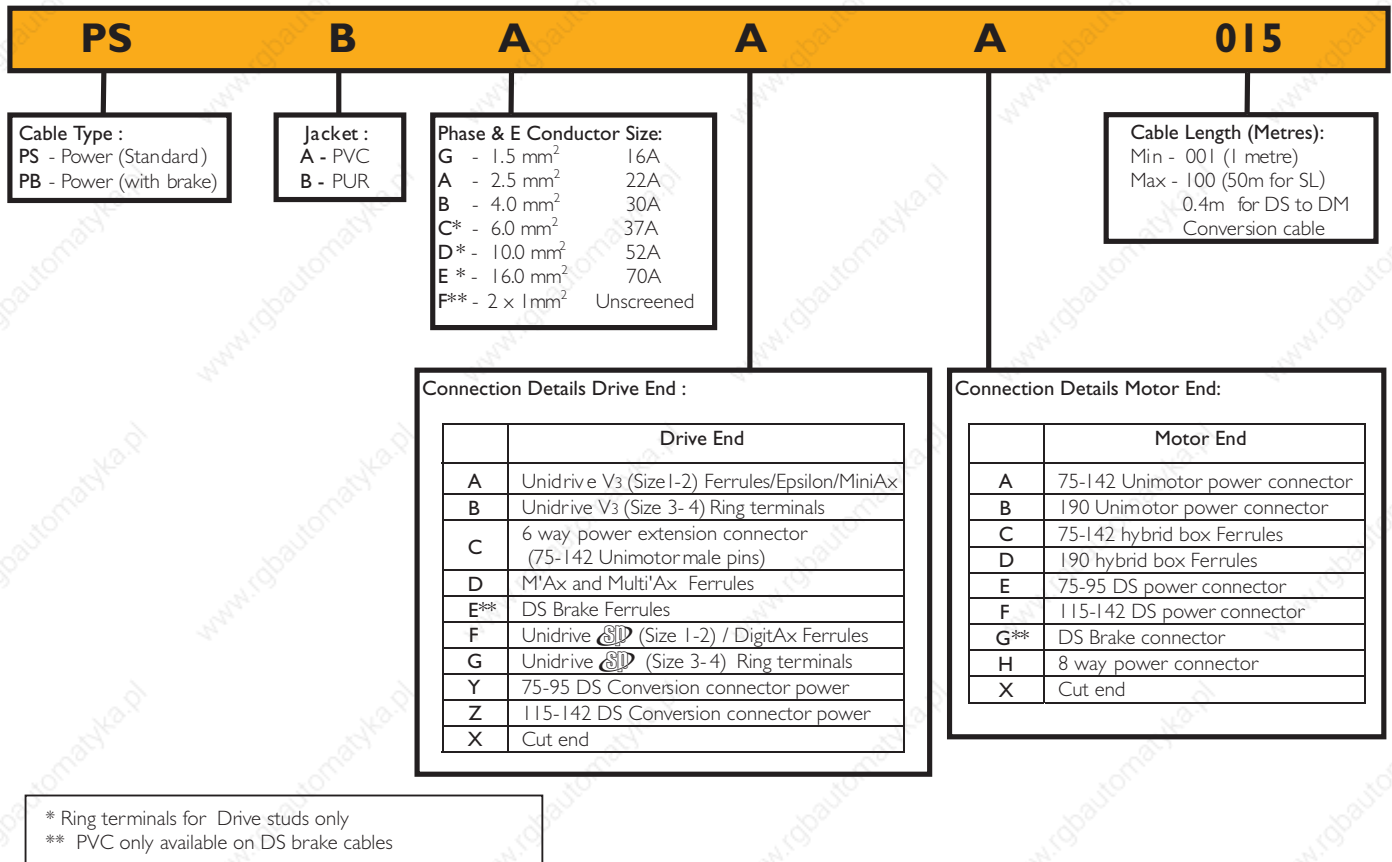

Unimotor (SLM) Signal Cable selection

Cable type – Choose the cable type to match the feedback device.

Jacket – B is for a PUR sheath and is the standard selection.

Special options – A is for standard cable. L is for the low cost 8.5mm incremental cable.

Connection detail drive end – Select the correct drive end connection for the drive in use.

Connection detail motor end – Select the correct motor end connection for the motor feedback device in use.

Length – Numbers represent the required cable length in metres. Conversion cables will be limited to 0.4m only and the length is not required in the order code.

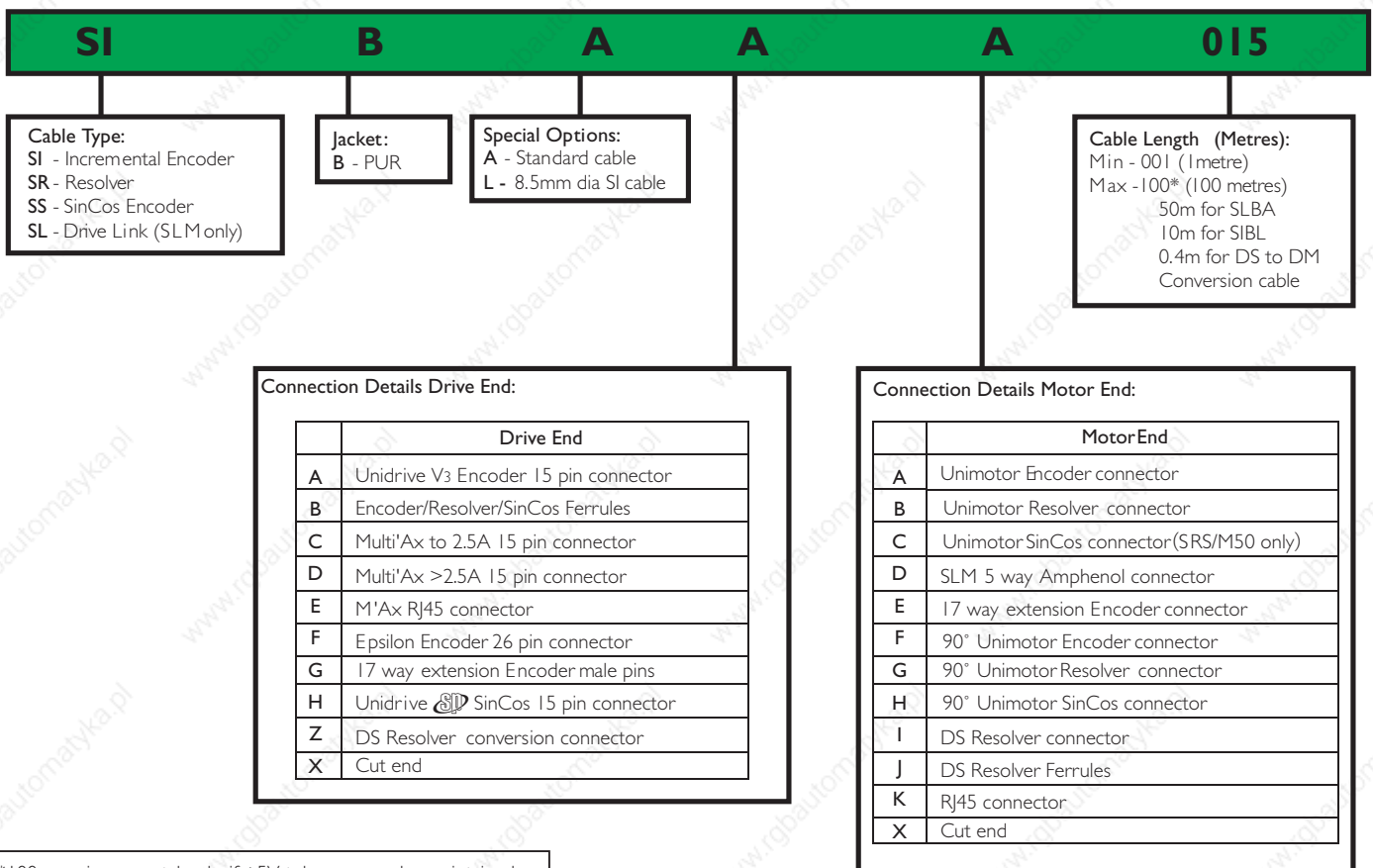

Motion Control with (SLM) partner

OVERVIEW

Control Techniques is furthering the growth of PC based and PC hosted motion technology and delivering more value to customers with a series of partnerships which match the company's revolutionary (speed loop (SLM) motor) system with PC based multi-axis controllers from the leading motion control system suppliers in the world, including:



The marriage of (SLM) technology with motion control technologies is an ideal one, achieving a synergy which gives OEMs that "extra competitive edge" through improved machinery performance. It also accelerates the increasing trend of replacing PLC systems with PC based architectures. For years, centralised motion control has been performed using PLCs which, because of the proprietary nature of their architectures and software, have effectively locked users into an increasingly costly and lower level of technology. Recently the combination of high speed PC hardware and softlogic programming packages has released this "gridlock", driving centralised control technology forward to new levels. This is especially true in the area of motion control, where "open" based and PC hosted controllers are revolutionising the market with their ability to synchronise and interpolate ever increasing numbers of machine axes in real time.

Despite these major improvements, the cry from the market is still "more", in terms of feedback resolution and performance, and "less", in terms of wiring and total installed cost. In case of PC based and PC hosted motion control this element is Control Techniques' unique (SLM) technology.

Transfer Technology

The success of M'Ax and MultiAx, indicates that the revolutionary performance enhancements provided by (SLM) technology benefits customers by being transferred into other motion vendors products. The exciting thing about these partnerships is the way in which they bring together several cutting edge technologies, in the process delivering more benefits to OEMs and End Users.

(SLM) Compatible Motion Controllers



Select, no. of axis and M'Ax & MultiAx combinations to suit applications

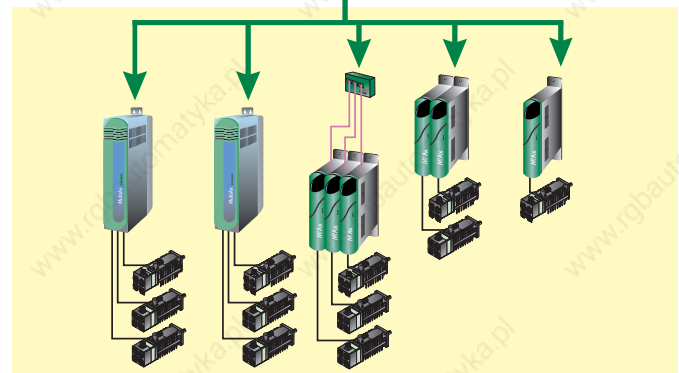

(SLM) technology

OVERVIEW

The (SLM) technology uses a combination of Control Techniques 4-wire, (SLM) ASIC and motor-mounted SinCos encoders to achieve an application invariant 20-fold increase in position feedback resolution (over 8.3 million points per revolution). This is achieved by integrating speed & position control within the feedback system on-board the servomotor. As a result, the (SLM) is able to overcome the degradation in performance experienced, with encoder feedback signals when synchronising multiple servo axes on machines as operating speeds increase. For the ultimate interpolated multi-axes performance, control loops are deterministic and synchronised to give the lowest jitter in the industry - of 50 nanoseconds.

(SLM) technology – Your Control Benefits

- Perfect trajectory following – high resolution feedback
- Perfect linearity on velocity feed forward
- Perfect dynamic response on acceleration feed forward
- High control loop bandwidth to achieve sub micron precision on position
- Reduced machine vibration - ultra smooth operation

(SLM) Partners

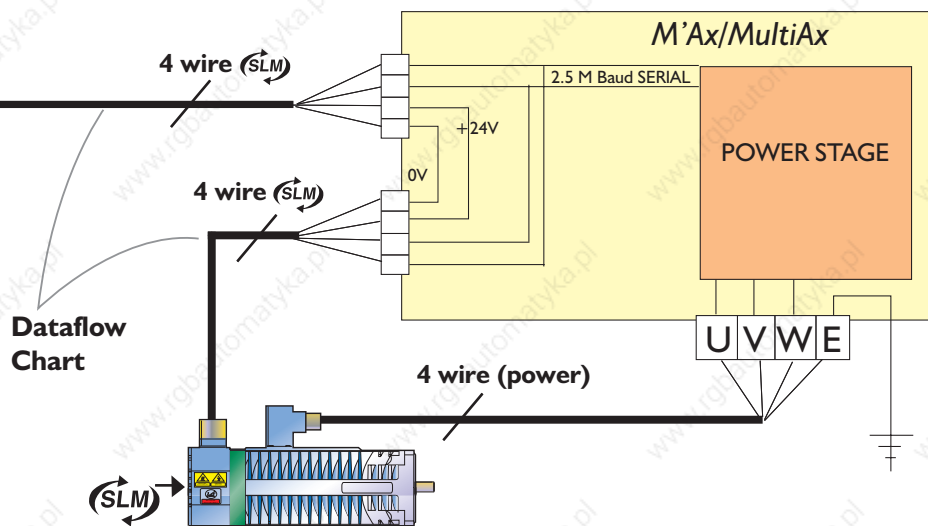

(SLM) Communications Protocol - Fundamental Cycle

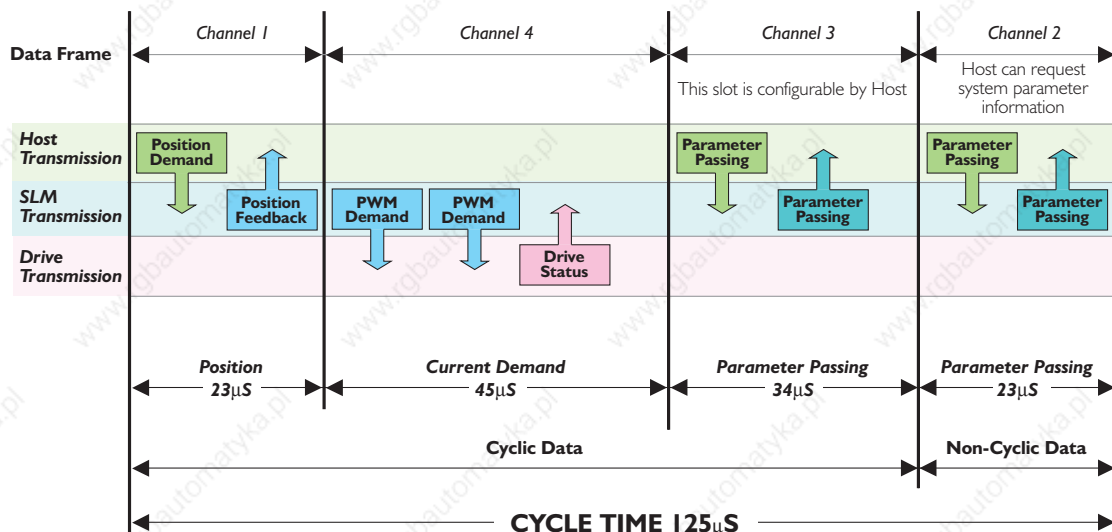

TRIO Motion Co-ordinators

PRECISION MOTION CONTROL

Trio's Motion Co-ordinators are fast, powerful and reliable. Easy to install and program, they share a range of common features that ensure maximum system performance with minimal programmer training and simple system upgrades.

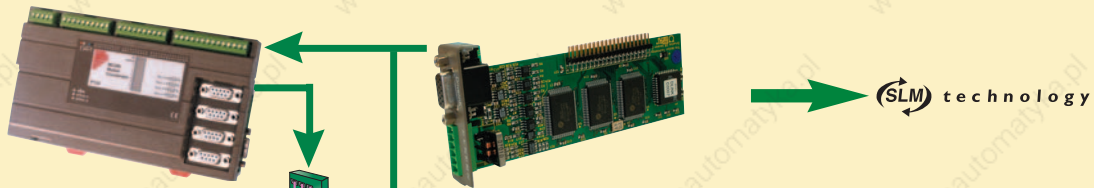

The Trio Advantage:

- Choice of 2 Motion Co-ordinators
- Both accept 3 Axis (SLM) Daughter Boards
- Approved for use with M'Ax and MultiAx
- MC 206 +1 (SLM) Daughter Board = 3 axes
- MC 224 +4 (SLM) Daughter Board =12 axes
- Axes not used by (SLM) drives can be used for analog drives and additional communications interfaces

Motion Co-ordinators

- Use Digital Signal Processors (DSP)
- Allow Servo / Stepper combinations
- Have accurate, fast Real Number mathematics
- 256 max. Digital I/O expansion channels
- 32 max. Analog Input expansion channels
- Program transfers by a Flash Memory Stick

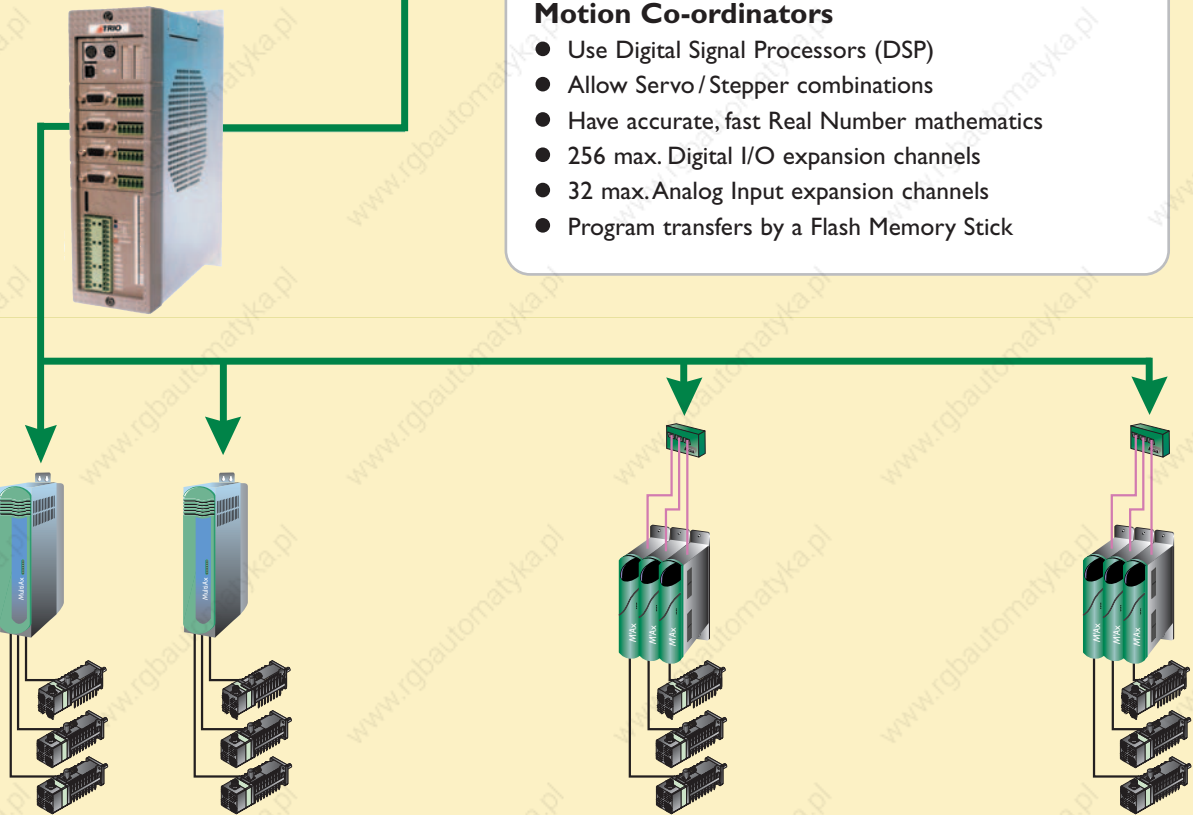

Up to 12 Digital Drives can be controlled with (SLM) Daughter Boards in MC224 Motion Coordinator

Centralised Motion Control
Motion Control with (SLM) Partners

TRIO MOTION CO-ORDINATORS - FEATURES

MC 206

DIN rail mounting, 120 MHz DSP, extensive communications options and up to 8 axes of stepper or servo control make this deservedly one of the world's most popular Motion Co-ordinators.



Equipped as standard with a single axis and a reference encoder, the MC206 may be fitted with a Trio (SLM)

Daughter Board to provide 3 further axes

ideally suited to Control Techniques digital drive systems.

For analogue systems, the standard axis provides the necessary $\pm 10V$ speed/torque control signals to the drive.

A further 3 axes may be accessed using Trio's unique internet-based Feature Enable Code system, which permits authorised customers to download an access code to provide the exact number of additional axes required for the application.

(SLM) Daughter Board

Trio's (SLM) Daughter Board provides the vital link between Motion Co-ordinator and your Control Techniques digital drive.

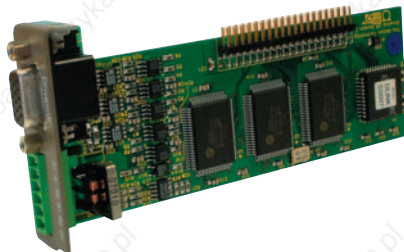

One Daughter Board will control up to 3 axes with each having an independent (SLM) channel to achieve the high speed update of 125 μS . Up to 12 (SLM) - based axes may be used in a Trio MC control system.

MC 224

Up to 12 axes using (SLM) technology 150 MHz DSP and up to 4 Daughter Boards for the ultimate in configuration flexibility with a wide range of communications options.

Axis Expander modules allow up to 4 additional Daughter Boards per module with 4 Axis Expanders per Motion Co-ordinators.



Trio Daughter Boards:

P200 - Servo with Encoder	P270 - SSI Absolute Servo
P210 - Servo with Resolver	P280 - Differential Stepper
P220 - Reference Encoder	P290 - 4-axis
P230 - Stepper Output	CAN/CANopen
P240 - Stepper with Encoder	P292 - 3 axis (SLM)
P242 - Hardware PSWITCH	P296 - Ethernet
P260 - Analog Output	P297 - Profibus

Motion Perfect

All Trio Motion Co-ordinators are programmed in Trio BASIC, a simple language which allows users to achieve remarkable results with minimal training.

Easy to learn, multitasking BASIC produces highly flexible program functionality, often in fewer code lines than many other systems.

By using the same language for all Motion Co-ordinators, Trio have significantly reduced training times for each new product.

Trio has also produced MotionPerfect, an application development environment which employs the Windows graphical user interface to further simplify the programming process.

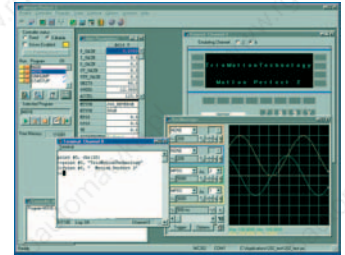

This offers a program editor, an axis tuning page, program tracer, oscilloscope function, and a keypad emulator.

MotionPerfect makes it easy to set-up and commission (SLM) drive systems by providing an interactive drive set-up wizard. The program allows fast automatic initialisation and takes full advantage of the plug and play features built in to the M'Ax and MultiAx servo drives.



Additional modules such as CAMGEN, to assist with programming CAM profiles, DocMaker program analyser and report generator, and Cad2Motion, to translate CAD drawings into BASIC programs are also available. MotionPerfect software is supplied for download free of charge from the Trio website at:

www.triomotion.com

OPEN PC MOTION CONTROL WITH M'Ax AND MultiAx SERVOS

Nyquist
Industrial control



Introduction

The CT3000™ Motion Controller is designed for advanced multi-axis solutions in combination with servo drives based on the (SLM) technology. The intelligence of the CT3000 takes care of the real-time, high-speed synchronisation and interpolation required between the axes. The industry standard high-speed IEEE-1394 FireWire network connects the CT3000 to the open PC-based platform.

FireWire based Motion Control networking

FireWire networking technology has ignited the Motion Control market in virtually every machine control application domain today. The new CT3000 Motion Controller offers a range of characteristics and functions specifically designed for OEM motion engineers. The FireWire network allows sample-synchronous multiple-axis Motion Control. Real-time, deterministic communication and control between multiple Motion Controllers is fully supported. An open interface towards the Motion Controllers is provided for Microsoft Windows NT, NT Embedded, Windows 2000 and Windows XP.

Highlights

- Fast, multiple axis synchronization over FireWire @400 Mb/sec
- Fully digital interface to servo drive with, (SLM) technology eliminates +/-10 V analog reference
- 6 axis unit, connectable up to 256 axis
- Open PC-based motion control software environment supported by Windows NT, NT Embedded, Windows 2000 and Windows XP
- Real-time, deterministic communication and control between multiple CT3000 Motion Controllers
- Easily expandable with other 3rd party FireWire products
- Simple to set up, seamless integration, less wires, lower cost!

Full digital chain

All servo drives based on the (SLM) technology can be controlled by the CT3000. MultiAx servo drives (triple axis unit) can be connected to the CT3000 by a single communication cable (10 core screened). This reduces cable count and installation costs, as the many control connections between Motion Controller and drive are replaced by one communication cable. Furthermore, the feedback between the servo drive and motor utilises 4 core screened cable simplifying cable requirements.

With (SLM) technology very high resolution feedback (8.3M counts per revolution, velocity loop) delivers extremely high performance and smooth rotation for demanding multi axis applications.

The CT3000 is equipped with all types of connectivity to realise high-end control. For every (SLM) axis, there are motion related I/O available, like limit-switch, position latch, markers, etc. Additional encoder inputs for electronic gearing and some general purpose I/O (digital and analogue) complement the I/O. Other general machine I/O is connectable over the FireWire network.

CT3000™ - DESIGN FEATURES

Compatible Motion Control

Drive Chain Functionality with M'Ax and MultiAx

Designed for OEM applications, the CT3000 Motion Controller is compatible with Control Techniques M'Ax and MultiAx range of servo drives. One CT3000 is able to control up to six axes. Controller interconnection by FireWire enables you to build applications up to 256 synchronised axes.

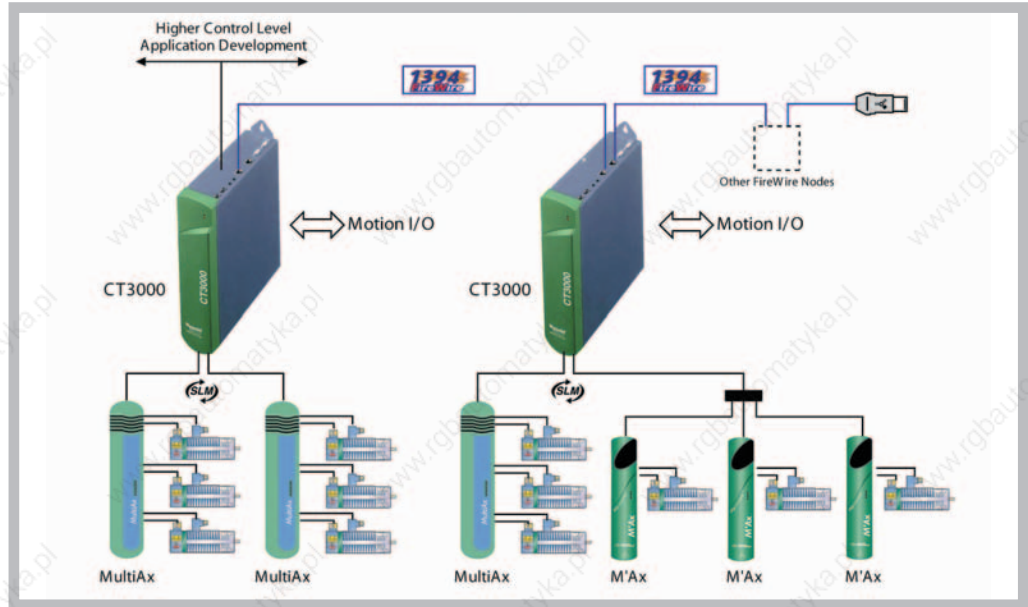

NYCeTalk Rapid Application Development Environment



It's Easy to Use

The CT3000 Motion Controller is supported by the NYCeLauncher application development environment. Automatic installation from CD-ROM enables OEM users to get the system up and running within 30 minutes.

To assist in commissioning there is a NYCeTuner wizard that guides you step by step through the axis set up. Without programming this tool allows the easy testing of all axes. Writing application programs is made easy by the NYCeTalk software. High level interpreter commands are easy to understand and may result in application programs of only a few lines. The software also has watch-windows (I/O and status) and on-line help.

SPECIFICATION

Number of axes:	6 Axes interfaces to control (SLM) - based servo drives
Transmission procedure:	Standard FireWire communication according to IEEE1394a, up to 400 Mbit/s
Functionality:	Full NYCe3000 Software Release support
Diagnostics:	Full support for CT3000, MultiAx and M'Ax servo drive series
I/O:	<p>Motion Related I/O per (SLM) -Axis:</p> <ul style="list-style-type: none"> -6 Digital inputs (1 position latch, 1 area, 1 alarm, 3 free) -3 Digital outputs (all general purpose) <p>General I/O:</p> <ul style="list-style-type: none"> -Additional encoder input (S0S90,SSI,ENDAT) -6 Digital inputs -3 Digital outputs -2 Analogue outputs (16 bit) -2 Analogue inputs (12 bit) <p>All inputs conform IEC1131-2, 24 Volt isolated.</p> <p>All outputs conform IEC1131-2, 24 Volt isolated, short circuit protected.</p> <p>Every output 0.5 A. Total load 4 A.</p>
External Expandability:	Expandable with other FireWire products
Mechanical dimensions:	h=273, d=247, w=75 (mounting plate 360 x 75) Minimum clearance above and below 100 mm
PSU Requirements:	24 Volt DC, +/-20%, 1 Amps (excluding I/O)

SYSTEM LEVEL SOLUTIONS

The UMAC System

The UMAC (Universal Motion and Automation Controller) is a modular system designed for you to customize to your application needs. UMAC utilizes the latest in DSP technology, including the Motorola 56k series DSP microprocessors. Its fast and precise calculation capabilities translate into a highly accurate and fast-paced motion trajectory calculation and control. In addition, we use a high-level BASIC-like language for performing real-time custom servo loop tasks in an Open Servo structure. Our continuously increasing computational speeds (40-160 MHz) enable our motion controllers to have many advanced features.

With six generations of proven in-the-field motion controllers, we offer a broad and diverse line of motion control products. From 1 to 32 axes of linear or rotary servo, stepper or hydraulic motion in any combination, including a variety of analog or digital I/Os, different types of encoder feedback, analog (+/-10V) and digital (SLM), direct PWM or MACRO outputs to servo amplifiers, as well as pulse and direction output for steppers. Also, RS232, USB and Ethernet communications. We can provide the best solution for today, with the best upgrade path to the future.



Each UMAC system is expandable and scalable by adding accessory cards to a rack or by connecting multiple racks together via Delta Tau's real time fiber optic field bus (MACRO). In addition, a PC/104 computer can be installed inside the UMAC system rack yielding an incredibly powerful controller within a compact industrial package.

ACC-69E (SLM) Interface

The ACC-69E Axis Expansion Board provides three or six channels of servo interface circuitry for UMAC controllers. The ACC-69E is part of the UMAC or MACRO Pack family of expansion cards and these accessory cards are designed to plug into an industrial 3U rack system (UBUS). The information from these accessories is passed directly to the Turbo PMAC2 CPU via the high speed UBUS back plane

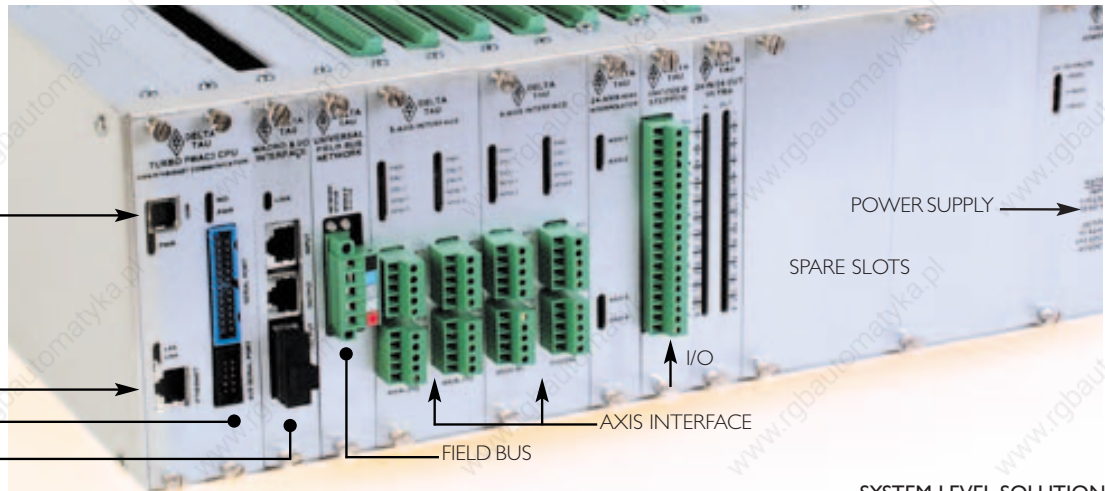

USB

POWER SUPPLY

SPARE SLOTS

ETHERNET

TURBO PMAC2 CPU

MACRO FIBER INTERFACE

AXIS INTERFACE

FIELD BUS

I/O

SYSTEM LEVEL SOLUTION

UMAC – DESIGN FEATURES

Features

- Advanced PID and pole placement servo algorithms
- Multitasking of up to 16 motion programs and 64 PLC
- Up to 32 axes of control in 16 coordinate systems (multi-axis trajectory control, multitasking)
- Dynamic multi-block lookahead for robust acceleration control
- Forward and inverse kinematics (robotics and other non-Cartesian actuators)
- Reverse and retrace capabilities (welding, cutting, EDM)
- Acceleration and jerk control (smooth, jerk-free motion)
- Cascaded servo loops (tight coupling of velocity/force loop)
- True S-curve acceleration-splines (smooth trajectory control)
- Coordinate translation and rotation (2D and 3D)
- Lead screw and backlash compensation
- 24-bit hardware position- and compare capture
- 48-bit floating point and integer calculations (precision)
- User-written servo capabilities for custom servo algorithms
- Servo loop update rate up to 6.25 microseconds per axis
- Types of communications: USB, Ethernet (UDP/TCP/IP) or RS232

The ACC-69E (SLM) Interface Board

Up to six ACC-69E boards may be connected to one UMAC, providing up to 32 axis channels of servo interface circuitry. The ACC-69E board contains a micro-controller and it has a highly integrated 6-channel PMAC2-style memory map. The ACC-69E plugs into the back plane and uses one slot a UMAC Rack. The ACC-69E comes standard with 6 servo interface channels, which are brought out on high density 15-pin DSUB connectors.

- Velocity-based output commands (selectable to Torque mode by user)
- High-resolution absolute encoder feedback (up to 22 bits)
- 4 channels of timestamp based trigger position capture capability
- 4 differential trigger inputs provided for position capture.
- Interface for the communication to/from the M'Ax™ or MultiAx™ drives
- 3 input flags (PLIM, MLIM, HOME) per channel

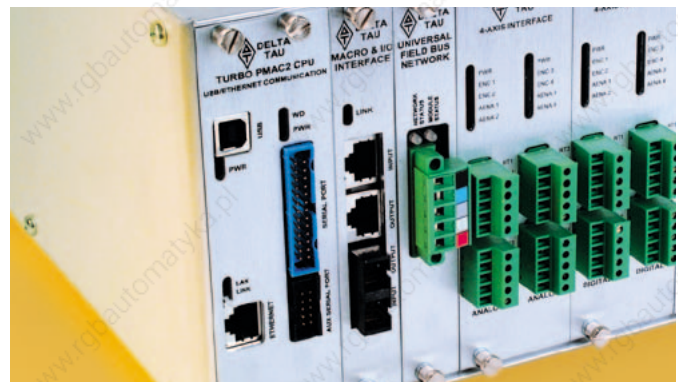

TURBO UMAC WITH USB AND ETHERNET

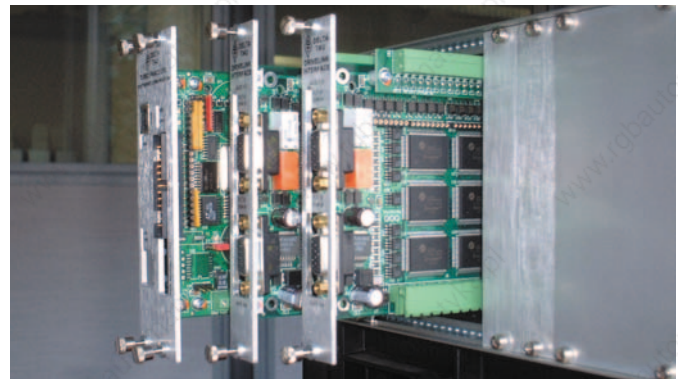

12 AXIS (SLM) WITH UMAC



UMAC MACRO

NcWorks2 AND (SLM) - THE pantec PLATFORM FOR MULTI-AXIS APPLICATIONS



For Multi-Axis applications exactly right

The modular Multi-Axis Controller NcWorks2 offers a reliable, extendable Motion-Control system for demanding Multi-Axis applications.

The Main Unit (a complete controller for 8 Axis with (SLM)-outputs, I/O's, Ethernet Port) and the (SLM)-Extension give you an almost as desired scalable system. Each machine obtains exactly what it requires in control facility – no less and no more.

Successful systems as one unit

The controller joins succesful systems from the market to one unit. The CPU used is PMAC from Delta Tau, communication to the Motion-Controller takes place via Ethernet, MACRO connects several NcWorks2 – units synchronously – and the drives are integrated digitally with (SLM).

Prepared for todays challenges

The combination of NcWorks2 and (SLM)-Drives embodies the trend at the present time:

- compact in size
- modular in structure
- synchronised networking
- Ethernet-based communication to controller

Synchronised Networking for modularity

NcWorks2 Units can be distributed decentral, but are working synchronously anyway. The units are connected via Macro (a fibre optics, high bandwidth real time bus) - a bus for distinct real-time applications.

This means 24 synchronised (SLM)-Axis per NcWorks2 - Unit in synchronised networking with up to 256 NcWorks2... Multi-Axis application in a new dimension.



NcWorks 2
Main Unit +
(SLM)-Extension

Main Unit	(SLM)-Extension
8 (SLM)-Axis	16 (SLM)-Axis
46 digital in, 8 analog in	48 digital in
30 digital out 24V/0.5A, 8 digital out 24V / 1.5A	32 digital out 24V/0.5A, 16 digital out 24V/ 1.5A
Ethernet, CANopen, Modbus	
Synchronised networking of Main Units via MACRO	

NcWorks2 MAIN UNIT - DETAILS

I/O-Section

Socket Block Tension Clamps for 46 digital in, 38 digital out; 8 analog in

CPU

The core unit of the NcWorks2 System is the PMAC multi axis controller from Delta Tau. Apart from the simple management and programming facility for the axis, the operating system also offers many other additional functions:

- up to 32 synchronised axis in 16 different coordination systems
- IEC61131-compatible PLC- functionality
- G-Code for CNC-control
- acceleration profile selection
- Lookahead acceleration-and speedoptimisation
- inverse kinematics for robot technology
- spline- and blending-functions
- capture-input for fast I/O's

(SLM) -SECTION

The Main Unit controls up to 8 (SLM)-Axis. There is no need for a linkage of the encoder to the controller because the encoder values are transferred serial via the (SLM) datalink.

NcWorks2 AND (SLM) :

- communication to the Motion-Controller via Ethernet
- unbeatable cost-/performance ratio
- the sizes of cabinets have previously always been more than halved upon fitting NcWorks 2 and Multi-Ax
- enhancement up to 24 (SLM) -Axis
- synchronised networking of NcWorks 2 - units via MACRO-Bus
- more than 1500 NcWorks-units (about 12'000 Axis) in different applications worldwide in use

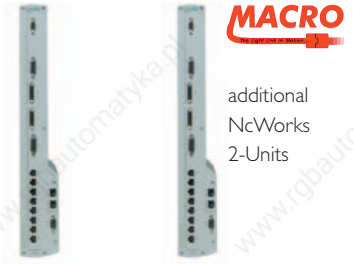
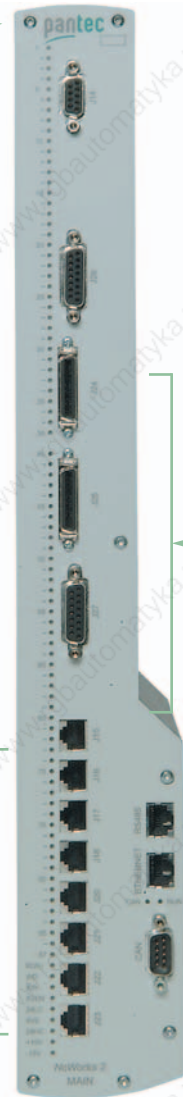

MACRO

additional NcWorks 2-Units

synchronous network

MACRO-Bus for synchronised networking of several autonom Main Units

PWM-Section

- Encoder-input
- PWM-output

The NcWorks 2 main unit contains 2 encoder inputs for quadrature encoders as well as 2 differential outputs for direct-PWM

Interface-Section

- Ethernet
- RS 485
- ModBus
- CANopen



XCx THE CONTROLLER OF THE FUTURE



Puts Speed in Your Machine

1 (2)* millisecond PLC signal time from input to output on plant-floor I/Os, 1 (2)* millisecond CNC interpolation cycle.

Interpolates

Up to 16 (4)* CNC axes in different NC programs at the same time.

Synchronises

interpolated movements with switching process, e.g. position-dependent value switching or position detection with interrupt input.

Coordinates

path motions with technology parameters, e.g. welding current according to path feedrate.

Processes

not only circular and helical contours, but also freeform contours.

Transforms

any machine kinematic into Cartesian coordinates.

* () refers to XCx 300 unit

Control NC Servo Drives

Using **(SLM) technology** from Control Techniques available on the XCx 540 and XCx 300.

Connects the Sensor / Actuator Level

through fast serial-connected I/Os (or via CANopen, Profibus-DP and DeviceNet only on XCx300 and XCx 540).

Communicates

via Ethernet and TCP/IP in any factory network, via Profibus-DP and CAN in any system.

Visualises @ Web

in HTML and Java on any standard browser via its own web server and via OPC server for Windows via Ethernet.

Alarms

by text message to mobile or by e-mail with detailed messages such as "No coolant".

Records

Via serial interface directly to a connected printer.

DESIGN FEATURES

RS232 Interface

The RS232 interface is for serial connection of programming devices, logging printers and barcode readers.

Mounting

Mounting via DIN rail or using fixing holes.

Diagnostics

For on-site diagnosis, parameterising and testing the XCx sets up a reliable interference-free connection to external devices such as mobile phone, palmtop and laptop via the **infrared interface**. The LEDs give information on the CPU and PLC status, as well as the activity of the interrupt input/outputs.

Operating Mode Switch

The three-position **operating mode switch**. The PROG setting means PLC stop, programming mode. WARM is the default setting (warm start of PLC, retain variables), while COLD causes cold start of the PLC and the variables are deleted. The **reset button** under the front opening causes a hardware reset, equivalent to power off. This button functions only in PROG mode.



Operator Panels

The RS422 interface is for direct connection of operator panels and displays.

USB

The XCx can communicate with active terminal devices such as laptops via the **USB port**. The connection corresponds to USB version 2.0 with a type B connector.

RIODirect

The RIOdirect interface allows you to connect eight digital or analog modules via a special interface module.



Supply Voltage

Operating voltage 24V DC \pm 20% max. 5% residual ripple
Safety class IP 20 to EN 60529

Dimensions

(W x H x D) XCx 300 150 x 125 x 129 mm

XCx 540 274 x 125 x 129 mm

Climatic Conditions

Ambient operating temperature 0...+55 °C (category KV to DIN 40040)

Relative humidity 5 to 95%, no condensation

Electromagnetic Compatibility

Electrostatic discharge meets IEC/EN 61 000-4-2, severity 3

Electromagnetic fields meets IEC/EN 61 000-4-3

Interference suppression meets EN 55 011, EN 55 022

Performance

Approx. 0.2 ms (0.5 ms XCx 300)
for 1 K PLC instructions

Compact Flash

The operating system and user data are saved on a **compact flash**. The high memory capacity of the cards means that other data such as project documentation, maintenance manuals and the HTML and Java scripts of the web server is also available directly on the controller. The compact flash (CF) can be plugged and unplugged during operation and the system status is available on the PLC. Data that should be saved automatically on the CF (e.g. Log book) is saved on the controller RAM and transferred automatically when a CF is available again. The LEDs on top display the status of compact flash, RIOdirect and CAN network and modules.



Ethernet

IT networking is via **Ethernet** and TCP/IP with 100 Mbit/s (RJ45 connection). You can connect several controllers directly (via global PLC variables) or via a PC network. OPC servers then undertake communication with standard programs for visualization and operation.



SLM Module

The XP-DL (SLM) module from Control Techniques is a high-speed interface for four servo drives.

Expansion Slots

The XCx 540 offers four **expansion slots** for a wide range of modules. **RIO interface** - Together with the integrated interface (see "RIOdirect"), further RIOdirect interface modules allow up to 640 fast I/O channels.

Field bus and drive interface

- CANopen (also for drives)
- PROFIBUS-DP
- SERCOS
- (SLM) from Control Techniques
- \pm 10V analog modules

ISAC CNC

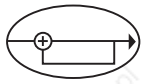

ISAC

Puts Speed in Your Machine

6 millisecond PLC signal time from input to output on plant-floor I/O. 0,3 millisecond CNC interpolation cycle

Interpolates

Up to 12 CNC axes and several axis group by concurring control between several interpolators.

Synchronises

- Interpolated movements with switching process, e.g. position-dependent value switching or position detection with interrupt input, and dependent movements between axis pair (Gantry)
- Several CNC connected via inter-process communication

Processes and Interpolates

Not only linear, circular and helical contours, but also freeform contours (electronic cam)

Transforms

- Any machine kinematics into Cartesian coordinates
- Any defined trajectory in a plane X-Y into a corresponding trajectory in any rotated and translated plane in the space
- Any tool tip trajectory into corresponding actuators movement (RTCP functionality)

Executes

Standard ISO commands and parameterised programs

Connects the Sensor / Actuator level

Via CANopen

Communicates

Via Ethernet and TCP/IP in a factory network

Visualises @ Web

In HTML and Java on any standard browser via its own web server

Alarms

By text message to mobile or by e-mail with detailed message such as "No coolant"

Diagnoses

Reliably and remotely via Ethernet and mobile phone

Records

Any meaningful event in a remotely controlled way

Offers

The ease of an unique software for milling and lathe machines and for all CNC models. The same PLC thus is valid even in case of CNC upgrade or downgrade

Control NC Servo Drivers

Via (SLM) for Control Techniques, via CANopen (DSP402)

Helps

In developing all the features of an application such as PLC, MMI and Working Programs

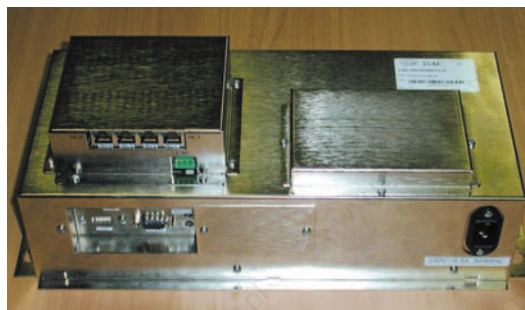

ISAC CNC - FEATURES

I/O

You can control digital or analogue signals via special interface modules through CANopen

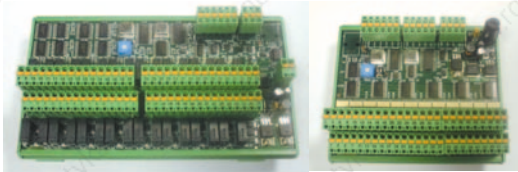

Compact Flash

ISAC CNC are predisposed to the use of Compact Flash: the operating system and user data are saved on such a mass storage. All the maintenance manuals and other documentation take place on the same media and are remotely available



Operator Panel

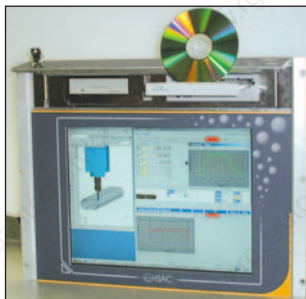

The screen is connected via LVDS interface or via VGA and the keyboard is connected via USB port

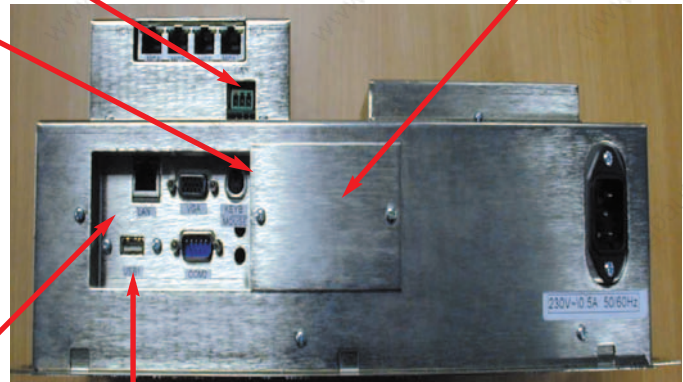

Ethernet

The networking is via Ethernet and TCP/IP with 100Mbit/s (RJ45 connection). The port can be used to connect either several CNCs or a supervisor PC



Mounting

Mounting using fixing holes

Supply Voltage

Operating Voltage 240 V AC (range 85-264)
 Safety Class IP 20 to EN 60529 for Case
 IP 65 for operator Panel

Dimensions

(W x H x D) (mm)
 SAB2001E: 440x215x180
 SAB2001HS: 434x345x247
 SAB2001M: 390x195x130

Climatic Conditions

Ambient Operating temperature: 0...+45 °C.
 Relative humidity: 5 to 95% no condensation

Electromagnetic Compatibility

Electrostatic discharge meets IEC/EN 61 000-4-2, severity 3
 Electromagnetic fields meets IEC/EN 61000-4-3
 Interference suppression meets EN 55 022
 EFT-Burst IEC/EN 61000-4-4

USB

The ISAC CNC can communicate with active terminal devices (such as CD-Rom, Floppy Disk, etc) via USB port

RS232 Interface

The RS32 interface is for serial connection of programming devices, logging printers and barcodes readers

LVDS

The LVDS Interface is for TFT screen connection

- DSP402 for motion control, DSP401 for I/O devices,
- DSP305 for layer setting services
- (SLM) for Control Techniques motion controls
- ±10V analogue interface for traditional motion controls

Networking

- Ethernet connection
- Modem

Performance

PLC: 80 KB in 0.3 msec
 CNC: Block Cycle Time: 500/sec

PLC Functionality with Unidrive

OVERVIEW

Unidrive , the AC and Servo drive is the true Solutions Platform, offering a wide range of PLC (Programmable Logic Controller) solutions giving users unparalleled flexibility in configuring PLC logic and implementing applications. Real cost and space savings are quickly achievable with the flexible modular Unidrive approach in selecting hardware and IEC61131-3 software.

Why Unidrive and PLC functionality?

Unidrive and PLC functionality helps maximise your productivity and profitability by offering performance and features that can make your machine run faster and under tighter control. SM-Applications range of option modules convert your Unidrive drive into a high-performance automation controller; removing the requirement for expensive PLC hardware and giving you the power and performance to enhance the productivity of your machine and factory. and are Control Techniques PLC configuration software products that facilitate these improvements by allowing you access to real-time processing and diagnostics.

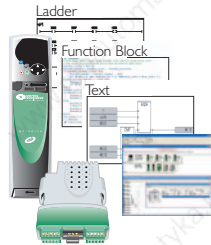

SAVINGS

- Equipment and machinery manufacturers as well as end-users can achieve lower total component costs using the 'no-extra-cost' onboard PLC functions of the Unidrive

- In more complex applications the modular hardware approach allows scaling of PLC processing power so that it more precisely matches the demands of the application
- Space Saving – the PLC options for the Unidrive save space since they are all contained within the drive
- Reduce commissioning time – Unidrive and its PLC options can be programmed together, using intuitive PLC programming language to IEC61131-3

PERFORMANCE

- The scalability of the PLC option module range allows users to substitute the Unidrive for the smallest Nano-PLCs up to large or advanced PLCs
- Multiple SM-Application option modules and drives can be networked together as part of a decentralised automation system in order to communicate and share information using the standard on-board protocol
- The synchronised real time interface between the Unidrive host and the SM-Applications Lite and SM-Applications option modules are achieved via the internal ultra-fast quad-port RAM. For example, the SM-Applications module can retrieve parameter information (such as changes in drive load) from the Unidrive in 10µs (turn around time of a traditional PLC to drive is approx 2ms)

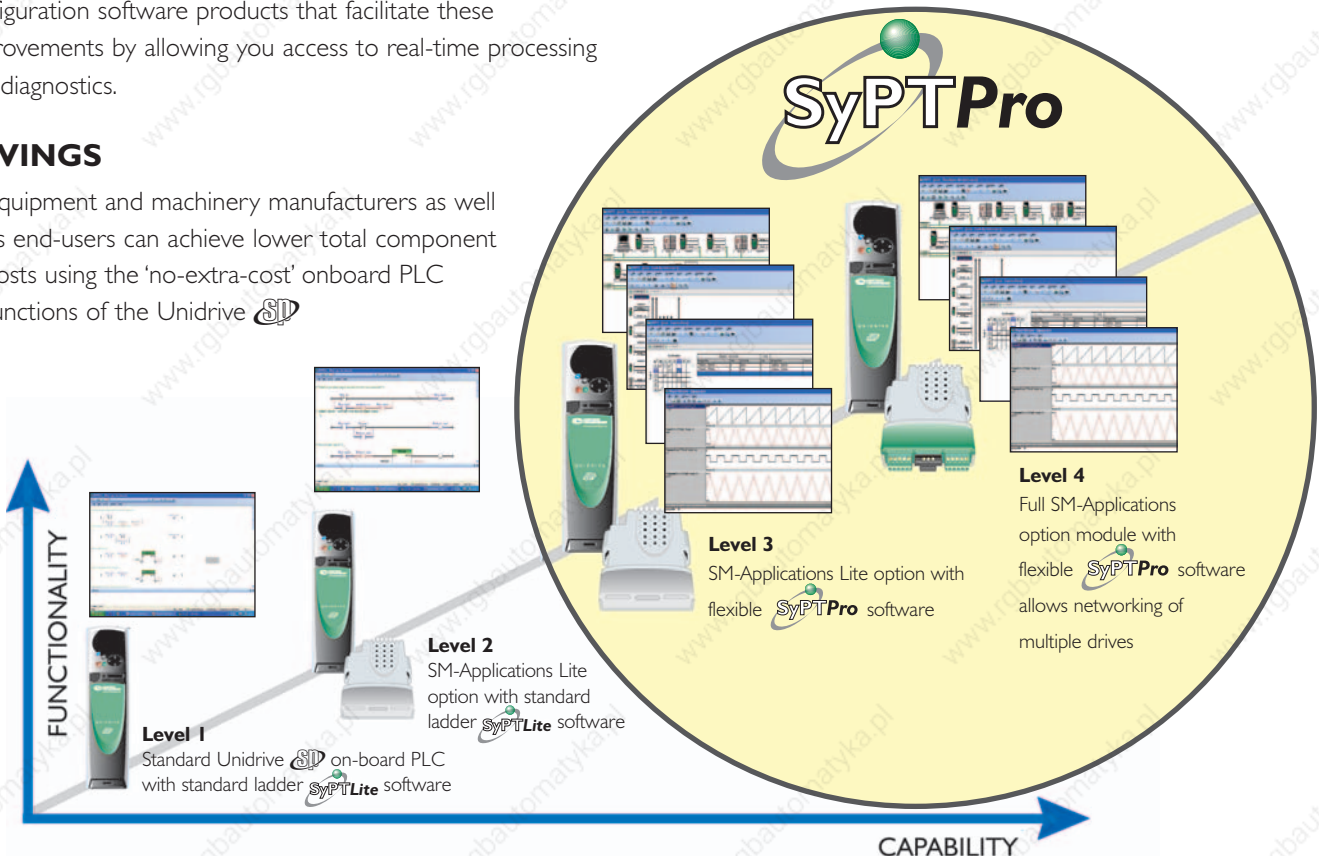

UNIDRIVE - THE SOLUTIONS PLATFORM DRIVE

- Global voltage availability, 200-690V, with full range of industrial output ratings – see Unidrive  section
- Universal feedback with 12 selectable encoder types including:
 - Quadrature, SSI, SinCos, Endat, Hiperface – integration with your motor feedback virtually guaranteed
- Cost and space saving design features including:
 - CTNet protocol for decentralised automation
 - Secure Disable input as standard to meet EN954-I cat. 3 – a must for modern machine builders
 - Integral EMC filter as standard meets EN61800-3 for global machine conformity
 - Optional Zero-space dynamic braking resistors
 - 48 -96VDC operation for low speed set-up/operation or mains supply back-up
 - 24VDC back up to maintain power for control, fieldbus and encoder for commissioning and monitoring with mains disconnected
- Two further option slots for extra I/O and a range of fieldbus options allow for “one click” upgrades
 - PROFIBUS DP, INTERBUS, CAN, CANopen, DeviceNet, Ethernet, SERCOS, SLM, CTNet



APPLICATION CO-PROCESSOR MODULES

Control Techniques are market leaders in intelligent drives, with an established heritage and reputation in providing the best drive performance and automation control from within the drives own footprint. The flagship product Unidrive  allows up to three drive-option modules to be simply clicked into place offering you significant advantages:

- Option Modules add only functionality required for your application
- Simplify the set up and diagnostics
- Offer value as you only pay for functionality that you require
- Allow thousands of combinations of intelligence, fieldbus and I/O to be used

By using SM-Applications range of option modules you can convert from Unidrive  drive into a high-performance automation controller, removing the requirement for expensive PLC hardware and giving you the power and performance to enhance the productivity of your machine and factory. Up to three SM-Applications modules may be fitted in each drive, giving you access to the ultimate performance.

SM-Applications



The SM-Applications module transforms your Unidrive  drive into a powerful automation controller that adds fast PLC functionality and can be integrated with operator interfaces, remote I/O and other intelligent drives via our drive-to-drive network CTNet. This gives you all of the benefits of a fully distributed control system including better performance, reduced cost and smaller electrical panel sizes.



Performances

The SM-Applications module contains its own high performance microprocessor, leaving the drives own processor to give you the best possible motor performance. It contains 384K of user program memory, meaning that you are never likely to be limited by the program size or processing power of the module.

Easy Powerful Configuration

The PLC functionality is programmed using  (System Programming Tool) allowing you to tackle automation problems from simple start and stop sequencing through to more complex machine and motion control applications. The device is programmed within an IEC61131-3 environment with your choice of three languages, meaning that you will be quickly familiar with the  intuitive user interface.  provides a suite of diagnostic and debugging features for maintenance and to help you get your solution into service faster.

Real-Time Control

SM-Applications gives you real-time access to all of the drives parameters plus access to data from I/O or other drives. The module uses a high-speed multi-tasking operating system with task update times as low as 250µs, fully synchronised to the drives own control kernel to give you the best possible performance for drive control and motion.

Inputs/Outputs

The module has two digital inputs and two digital outputs for high-speed I/O operations such as position capture or actuator firing and a fast optically isolated RS485 port, supporting standard protocols such as: Modbus for connection to external devices like Operator Interface panels or synchronous communication using the  protocol.

Standard Solutions

Where applicable standard software Solutions such as winder, flying shear and duty assist are available to help to simplify the development and commissioning process.

SM-Applications Lite

The SM-Applications Lite module is designed to solve your automation requirements where intelligence is needed on a standalone drive or a drive connected to a centralised controller connected via I/O or Fieldbus.



The Module provides many of the functions of SM-Applications but may be programmed using either **SyPTLite** or **SyPTPro**. **SyPTLite** together with SM-Applications Lite gives you an intermediate-level automation solution that is suitable for a wide variety of automation applications, while **SyPTPro** and SM-Applications Lite will allow you to exploit the full power and performance of the option module in stand alone applications.

Standard Solutions

Where applicable standard software Solutions such as winder, flying shear and duty assist are available to help to simplify the development and commissioning process.

Application Programming Software

PROGRAMMING TOOLS AND UTILITIES

Control Techniques drives help you to maximise your productivity and profitability by offering performance and features that can make your machine run faster and under tighter control. **SyPTLite** and **SyPTPro** are Control Techniques PLC configuration software products that facilitate these improvements by allowing you access to real-time processing and diagnostics.

Free Software

SyPTLite is a free of charge software package that offers you simplicity and ease to use with performance suitable for the majority of simple applications.

Professional Software

SyPTPro is the professional programming tool that extends the functionality of **SyPTLite** with network configuration/management, multi-tasking and multi-language programming allowing you to fully exploit the drives hardware and applications option modules.

Example of PLC Functionality with Unidrive **SD**

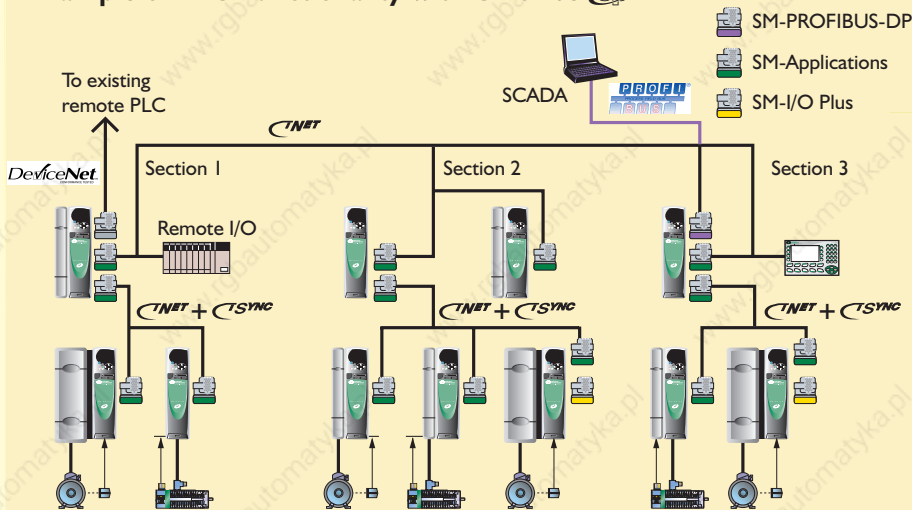

ULTIMATE FLEXIBILITY

The flexibility of the Unidrive **SD** together with the option module range makes the Unidrive **SD** the perfect Solutions Platform for any automation system.

The SM-Applications option modules can be used in almost unlimited combinations with fieldbus and I/O options in order to neatly dovetail into existing automation systems.

Alternatively, when starting out with a clean sheet of paper; the Unidrive **SD** can achieve the necessary cost and space savings by allowing the Project Engineer to accurately match the PLC and I/O requirements.

SyPTLite

SyPTLite is a ladder diagram editor that allows you to develop programs that can be executed onboard Commander SK with Logic-Stick, Onboard the Unidrive SD built-in PLC or on SM-Applications Lite option modules.

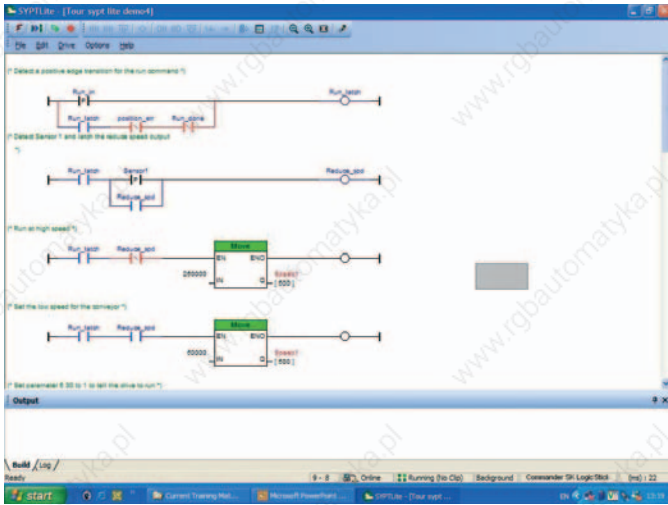

SyPTLite is designed to meet the needs of the majority of automation users wishing to extend the functionality of the drive to add simple PLC functionality such as drive control and sequencing. The software has been developed with a definite focus on intuitive ease of use allowing you easy access all of the drives parameters and to monitor and debug your program on line.

SyPTLite contains a comprehensive library of functions that is based on a subset of those available in the SyPTPro programming tool.

These include:

- Arithmetic Blocks
- Timers
- Multiplexers
- Bit Manipulation
- Comparison Blocks
- Counters
- Latches
- SMARTCARD

SyPTLite WITH UNIDRIVE SD ONBOARD PLC

Unidrive SD supports ladder-programming capability, i.e. the drive itself is capable of storing and executing a SyPTLite program without the requirement for additional option modules. The drive is prioritised to execute all motor control related functions first and will use any remaining processing time to execute the SyPTLite ladder diagram as a background activity.

The SyPTLite program may be copied to or from the Smartcard on the drive, allowing the data to be safely stored or retrieved for serial machine manufacture and maintenance purposes.

SyPTLite WITH SM-APPLICATIONS LITE AND UNIDRIVE SD

The SM-Applications Lite contains it's own high-performance microprocessor, of the same type as used in the drive, giving you access to a step change in PLC power and more than doubling the program size available up to 10kb. Using this option module gives you the flexibility to decide how your program task will run, either background or cyclic. The cyclic task means that the program will start on a fixed time-base that is synchronised with the drives own internal control loops. The time-base is selectable between 1 – 200ms.

SM-Applications Lite and SyPTLite offer a compelling alternative to traditional mini-PLC systems, in application where cost, foot print size or performance is important.

Note: SM-Applications and SM-Applications Lite can only be used with Unidrive SD.

Note: Full SM-Applications does not support SyPTLite programs.



SyPTPro - SYSTEM PROGRAMMING TOOLKIT

Overview

SyPTPro is the professional drive programming toolkit for OEM's and End Users who wish to maximise the performance of their machines and factory. This IEC61131-3 programming software offers greatly enhanced functionality allowing you to connect drives, Operator Interfaces and I/O to a network and configure how they exchange data. SyPTPro allow you to program in your choice of three different languages, with a real-time multi-tasking environment. It contains a suite of monitoring and diagnostics features that help you to reduce the time it takes to develop your programmes and allows you to get your machine into service faster.

SyPTPro may be used to program Unidrive SD with SM-Applications and SM-Application Lite Option modules and Mentor II DC Drive with MD29 option modules.

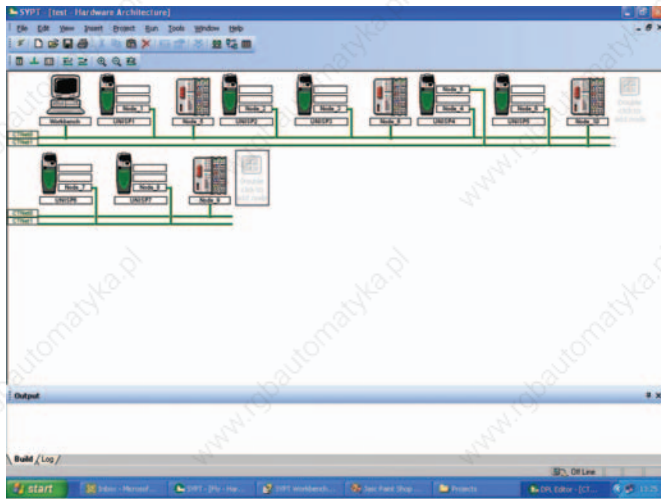

Industrial Network

SyPTPro allows you to configure a single drive or a complete drive system connected to a network. CNet is an industrial network designed to be deterministic, robust and tolerant to noise and interference. An OPC server is available free of charge from your local Control Techniques Drive Centre or Distributor.

Programming

SyPTPro allows you to program in your choice of three programming languages; these are Function block diagram, Ladder diagram and DPL (Drive Programming Language), and offer a multi-tasking environment where the tasks are scheduled according to the required speed of execution or triggered by events.

Function Block

SyPTPro incorporates an IEC61131-3 function block diagram editor, and comes with a library of more than 250 function blocks for both simple and complex functions. These embed years of application experience to make your software easier to write and easy to re-use. Additionally you can create a library of your own function blocks or update your library via our online user resources – SyPTPro.com. All function blocks may be used in any of the three languages.

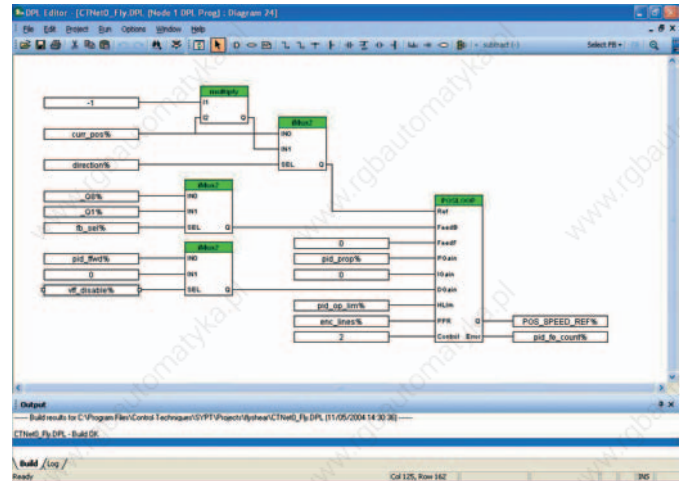

Ladder

SyPTPro incorporates an IEC 61131-3 Ladder language editor. This form of programming will be familiar to all PLC programmers and is the ideal format for sequencing and I/O control.

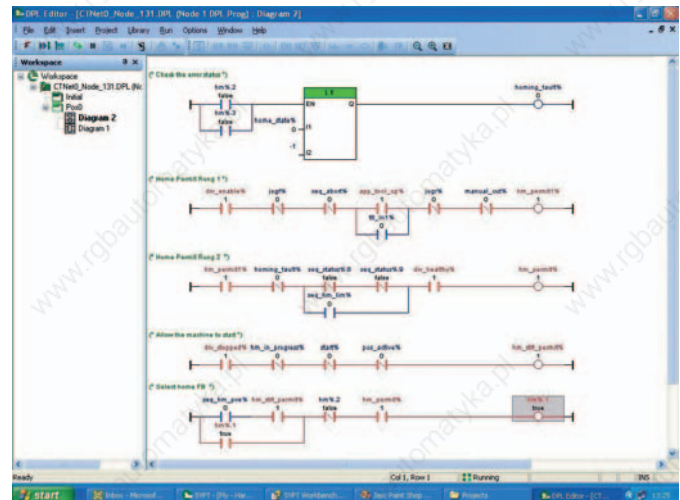

DPL

Drive Programming Language is a structured text language, as easy to use as BASIC, incorporating many standard constructs, such as IF, THEN, ELSE, and FOR, NEXT loops. DPL is ideal for initialising, configuration and general programming.

Diagnostics and Debugging

Good diagnostics are essential and ensure:

- Software development time is minimised
- Commissioning time is reduced
- Downtime is cut dramatically

SyPTPro contains a suite of diagnostic tools that help you to find problems with the system or software quickly and easily. When connected on-line, **SyPTPro** shows you live real-time views of variables in Function Block Diagrams, Ladder Diagrams and DPL, and allows you to execute program stepping and breakpoints.



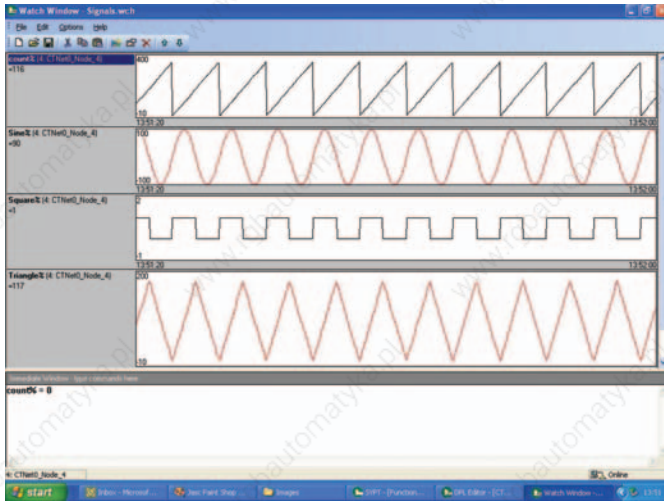

System Watch Window

Allows you to monitor real-time variables and parameters from a single drive or multiple drives.



ORDERING

PLC Functionality

Level	Software (IEC 61131-3)	AC Drive**	Option Module	PC to Drive Cable
1	SyPTLite Free with drive	Unidrive 	None required	CT Comms Cable
2	SyPTLite Free with drive	Unidrive 	SM-Applications Lite	CT Comms Cable
3	SyPTPro	Unidrive 	SM-Applications Lite	CT Comms Cable
4	SyPTPro	Unidrive 	SM-Applications	CT Comms Cable

** For Unidrive  information see section 3.1 or go to www.controltechniques.com



PLC LEVEL 1

Functionality

- Create your own PLC ladder logic programs on the standard Unidrive or Commander SK
- Functions include all standard PLC logic functions, timers, counters... and many more
- Replaces relay logic components as well as nano-PLCs and saves space
- The PLC's program is executed as a background task by the control processor on the Unidrive or Commander SK.
- 4 kbytes executable program capacity (including source code) – up to 50 ladder logic rungs maximum (7 function blocks and 10 contacts per rung) – depending on function blocks used. (more than 150 instructions)



Applications

- Replaces relay logic components, thresholds logic, comparators of analogue values
- Typical applications include: Ancillary pumps, fans and control valves, interlocking logic, sequencing routines

PLC LEVEL 2

Functionality

- Create your own PLC ladder logic programs on the SM-Applications Lite option module
- Functions include standard PLC logic functions, timers, counters... and many more
- Replaces micro-PLCs and saves space
- Real time PLC to drive communication via internal dual-port RAM
- Tasks – Initial, RealTime and Background
- 10 kbytes executable program capacity – up to 150 ladder logic rungs maximum (almost unlimited function blocks and contacts per rung). (more than 500 instructions)



Applications

- Replaces relay logic components, PID modules, thresholds logic, comparators of analogue values
- Typical applications include: Time critical sequencing, Cam switches, Hoist and crane control, Conveyor positioning

Hardware & Software



– IEC61131-3 Software free with registration via SyPTLite.com or www.controltechniques.com



Unidrive

Hardware & Software



– IEC61131-3 Software free with registration via www.controltechniques.com or SyPTLite.com

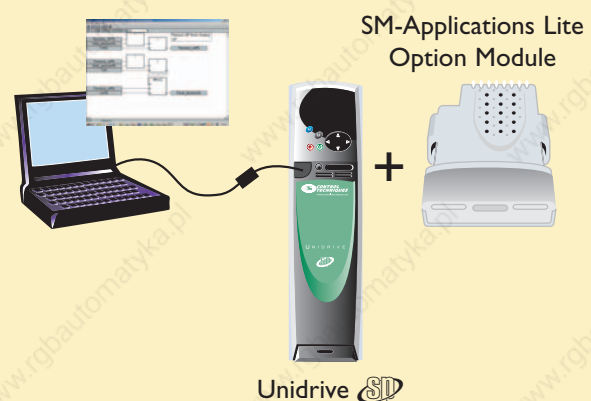

Unidrive

Set Up & Configuration Software

CTSoft, MentorSoft, SESoft, M'AxSoft and SXSoft

CTSoft, MentorSoft, SESoft, M'AxSoft and SXSoft are complimentary Windows™ based drive configuration tools designed to simplify the process of drive system design, set up, and diagnostics. The software enables the complete control and display of all parameters within a drive. The 'Softs' provide valuable drive data storage, retrieval and programming functions. These 'Softs' can be used off-line in the office or on-line on the plant floor.

Parameter programming and monitoring may be done using the menu list screens or dynamic graphical flow diagrams. Like the drives, parameters are grouped into logical menus of related parameters. Help menus and parameter descriptions are accessible by simply double clicking on the parameter of interest.

CTSoft, the newest member of the 'Softs' family, has a Drive Set-up Wizard that walks you through the basic set-up of a Commander SK and a Unidrive , and includes a Motor Database that may be modified to include the customer's motors. CTSoft conveniently provides a method to save multiple drive setups in one project group. Its multiple window viewing capability makes CTSoft the ideal commissioning tool.

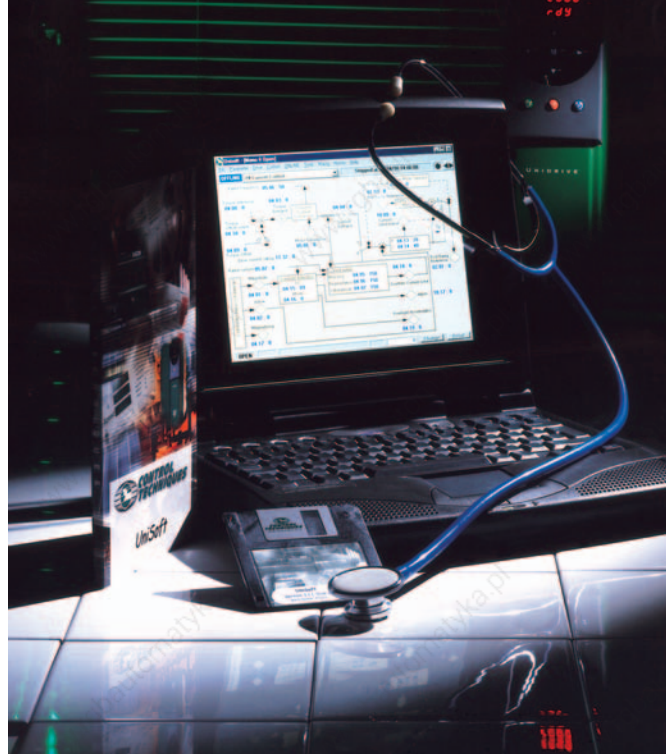

Some of its many features include:

- Built-in reference manuals and search functions that provide extensive "Help" files for both the drive and the Soft
- Graphical and dynamic illustrations of analog and digital I/O and internal signal flow
- Drive can be reset, set back to factory defaults and configurations stored via the Soft

PC Specifications:

- Microsoft Windows 3.1X, Windows 95 / 98 / 2000 / Windows NT 4.0 / XP; CTSoft requires Windows 98 or higher
- 486 processor (minimum); Pentium processor or higher recommended
- 8MB RAM, 4MB free hard disk space, RS232 port



ALL 'Softs' ARE PROVIDED FREE WITH THE DRIVE OR VISIT www.controltechniques.com/download.htm

PC / Drive Communication

Drive	"Soft" Order Code	Drive / Cable Connection	Serial Communication*	Cable
Unidrive 	CTSoft	Direct to drive	2-wire RS485	CT Comms Cable
Mentor II	MentorSoft	Direct to drive or MD29 / AN	RS485	CTD-PC-485
Commander SE	SESoft	Direct to drive (RJ45 port)	2-wire RS485	CT Comms Cable
Commander SK	CTSoft	Direct to drive	2-wire RS485	CT Comms Cable
Commander SX	SXSoft	Direct to drive	2-wire RS485	CT Comms Cable
M'Ax	M'AxSoft	Direct to drive	RS232	Consult Drive Centre

* For operational distances beyond 3 metres, when establishing a permanent serial connection, or when communicating with multiple drives, RS485 communication is required.

CTSoft Set Up Screens



Welcome

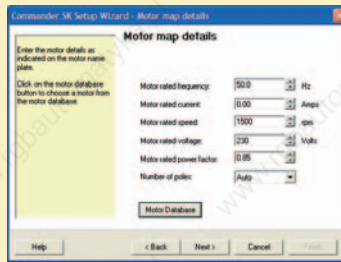

Motor map

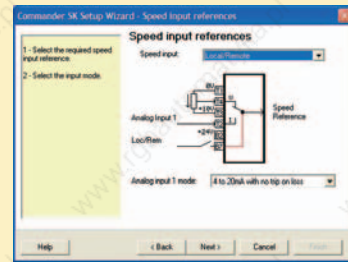

Speed Input

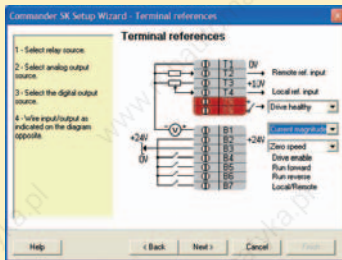

Terminal Set Up

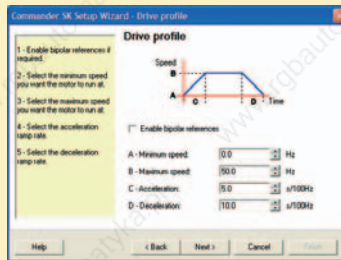

Drive Profile



Download

CTSoft Selected User Screens

Basic Set Up Offline

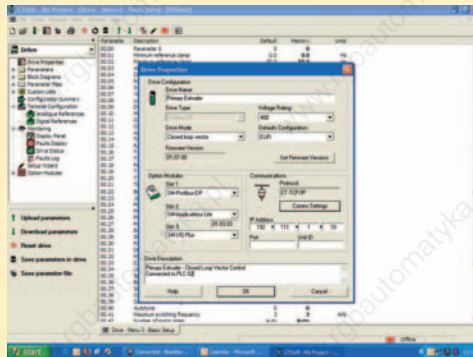

Monitoring Key Parameters

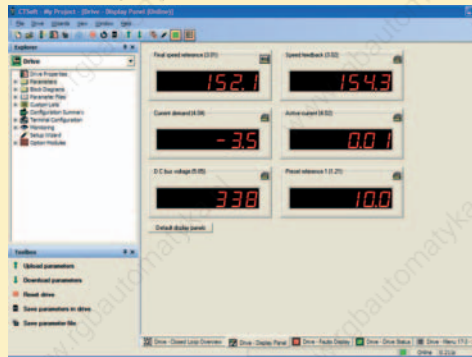

Logic Diagram

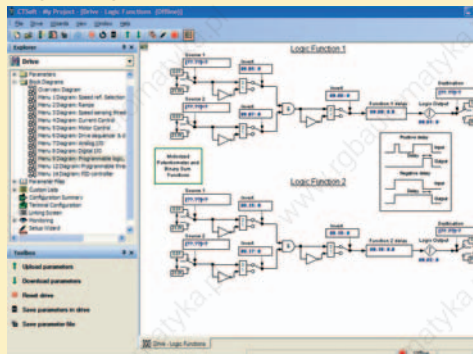

Drive Status Monitoring

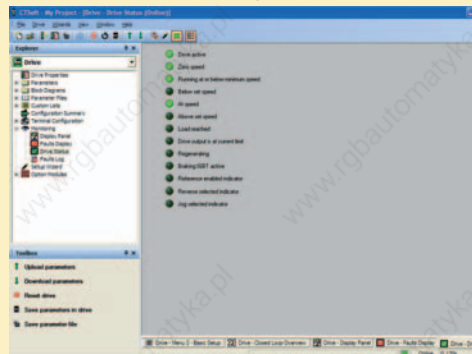

CTSize

Drive Sizing Software for Servos

1. Sizing your application is made easy with CTSize. Selecting the optimum system is simply done by going through the five tabs: Load, Motion, Reduction, Selection and Results.



2. Start by selecting one of the six pre-configured load types: Leadscrew, Rack and Pinion, Conveyor, Cylinder, Feedroll and User Defined and fill in the load details on the load tab.



3. Next, enter the load's motion profile, making use of profile type shortcuts or creating multi-segment profiles.



4. For speed reduction select from Belt/Pulley, Gear/Gear, Chain/Sprocket, or Gearbox for up to three separate stages of reduction.

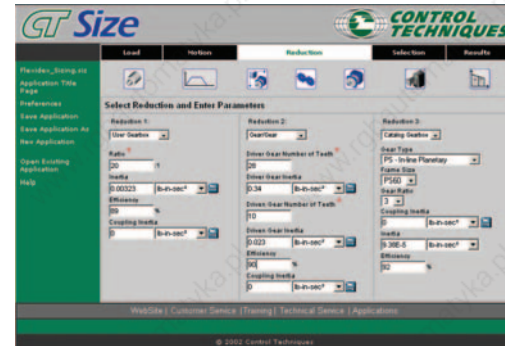

5. Use the selection tab to select from All products or narrow your search to a specific drive and/or motor:



6. The results tab will display the optimum motor/drive combination for your application.



VISIT
www.controltechniques.com/download.htm

Energy Saving Tool (CTSave)

CTSave is a complimentary Windows™ based software designed to display the energy and money saved by users who utilize CT drives instead of conventional products. Information collected by the program includes the cost/kW-hour, maximum power in kW or hp, annual consumption rate, and type of application (disc throttle, inlet guide vanes, dampers with forward or backward curve centrifugal fan). As the user enters or modifies the data, the savings at various flow rates are displayed graphically alongside the financial detail of savings, including the payback period. Both the data used in calculations and the results may be saved, recalled, edited and printed as required.

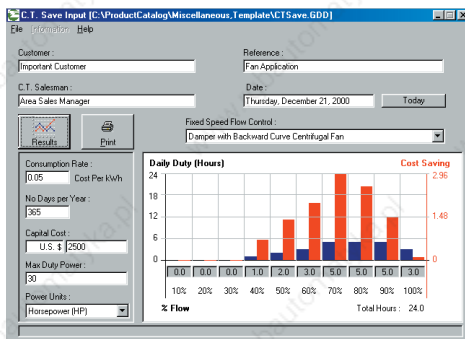
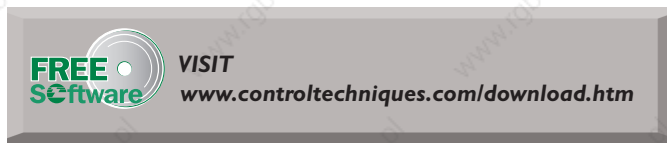

Application Programming Software

OVERVIEW

Control Techniques drives help you to maximise your productivity and profitability by offering performance and features that can make your machine run faster and under tighter control. **SyPTLite** and **SyPTPro** are Control Techniques' PLC and motion configuration software products that facilitate these improvements by allowing you access to real-time processing and diagnostics.

Free Software

SyPTLite is a free of charge software package that offers you simplicity and ease to use with performance suitable for the majority of simple applications.

Professional Software

SyPTPro is the professional programming tool that extends the functionality of **SyPTLite** with network configuration/management, multi-tasking and multi-language programming allowing you to fully exploit the drives hardware and applications option modules.

A Range of intelligent Drives

Control Techniques PLC and motion programming software is designed for use with our full range of AC and DC drives. – Commander SK, Unidrive **SD** and Mentor II.



Commander SK



Unidrive **SD**



Mentor II



APPLICATIONS CO-PROCESSOR MODULES

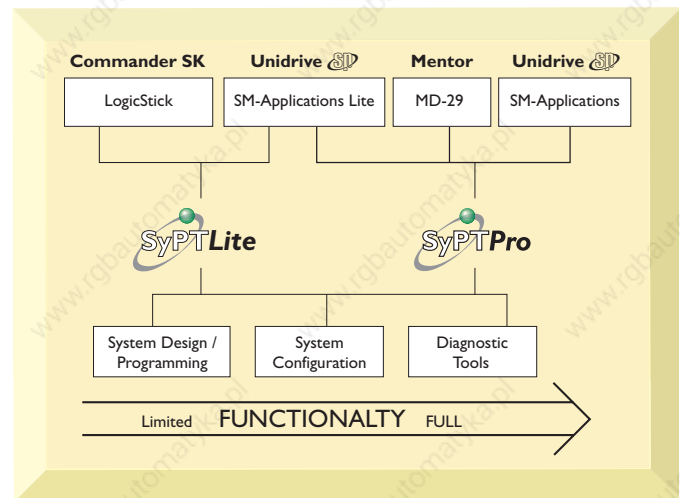

Control Techniques are market leaders in intelligent drives, with an established heritage and reputation in providing the best drive performance and automation control from within the drives own footprint. The flagship product Unidrive **SD** allows up to three drive-option modules to be simply clicked into place offering you significant advantages:

- Option Modules add only the functionality required for your application – a perfect match
- Simplify the basic product
- Offer value as you only pay for functionality that you require
- Allow thousands of combinations of intelligence, fieldbus and I/O to be used

By using the SM-Applications range of option module you can extend Unidrive **SD** into a high-performance automation controller; removing the requirement for expensive PLC hardware and giving you the power and performance to enhance the productivity of your machine and factory. Up to three SM-Applications modules may be fitted in each drive, giving you access to the ultimate performance and true multi-processing.

SyPTLite

SyPTLite is a ladder diagram editor that allows you to develop programs that can be executed onboard Commander SK with LogicStick, onboard the Unidrive SD built-in PLC or on SM-Applications Lite option modules.

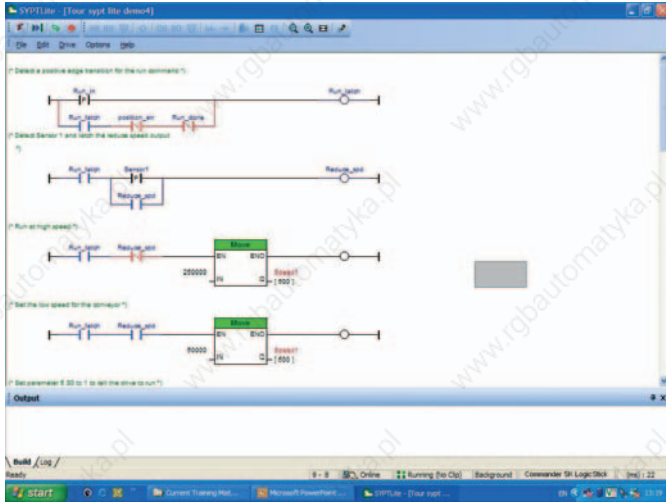

SyPTLite is designed to meet the needs of the majority of automation users wishing to extend the functionality of the drive to add simple PLC functionality such as drive control and sequencing. The software has been developed with a focus on intuitive ease of use allowing you to access all of the drives parameters and to monitor and debug your program on line.

SyPTLite contains a comprehensive library of functions that is based on a subset of those available in the full SyPTPro programming tool. These include:

- Arithmetic Blocks
- Comparison Blocks
- Timers
- Counters
- Multiplexers
- Latches
- Bit Manipulation
- SMARTCARD

SyPTLite with Commander SK Logic Stick.

Commander SK is Control Techniques simple and easy-to-use general-purpose drive. However, SK contains features and functions that you may not expect to find on a low-cost drive, such as the flexibility to program PLC applications onboard the drive. By inserting a logic stick into the fascia of the drive, you quickly add memory for program storage that allows you to write a PLC program using SyPTLite. The drive is prioritised to execute all motor control related functions first and will use any remaining processing time to execute the SyPTLite ladder diagram as a background activity.

Commander SK may be fitted with an I/O option that incorporates a real-time clock, allowing the drive to be used as a low-cost standalone solution in a wide range of applications such as dosing, lubricating, heating and ventilation.



FREE Software VISIT www.controltechniques.com/download.htm

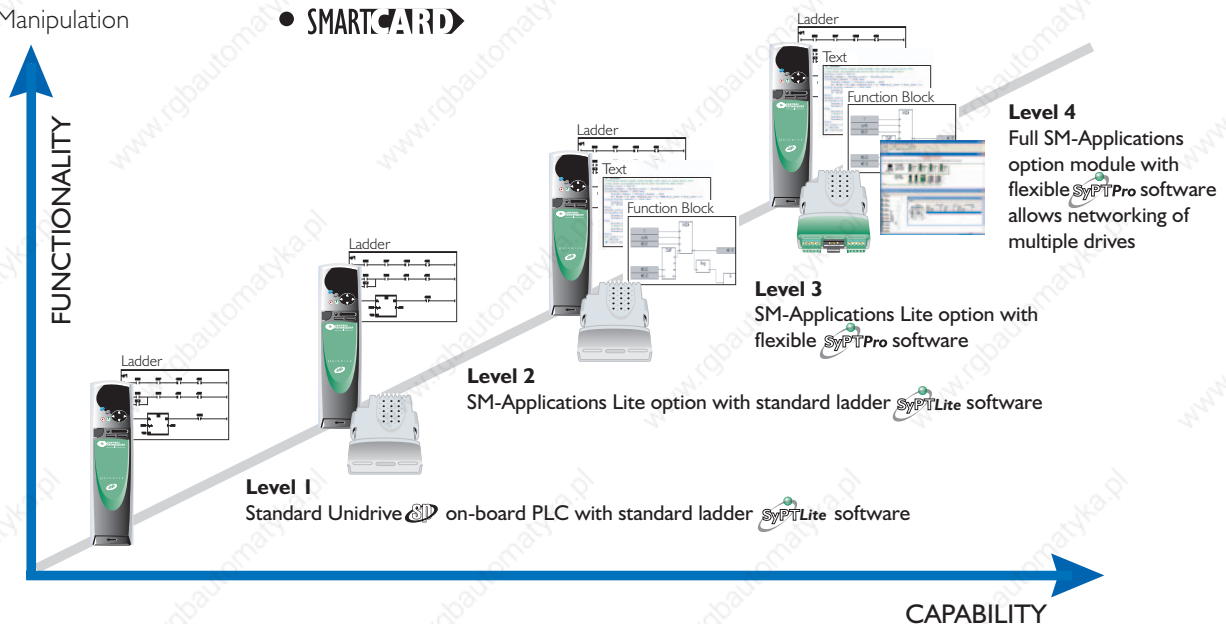

SyPTLite with Unidrive SD's onboard PLC

Unidrive SD supports ladder-programming capability, i.e. the drive itself is capable of storing and executing a SyPTLite program without the requirement for additional option modules. The drive is prioritised to execute all motor control related functions first and will use any remaining processing time to execute the SyPTLite ladder diagram as a background activity. The SyPTLite program may be copied to or from the Smartcard on the drive, allowing the data to be safely stored or retrieved for serial machine manufacture and maintenance purposes.



SyPTLite with SM-ApplicationsLite and Unidrive SD

The SM-Applications Lite contains its own high-performance microprocessor, of the same type as used in the drive, giving you access to a step change in PLC power and more than doubling the program size available up to 10kb. Using this option module gives you the flexibility to decide how your program task will run, either background or cyclic. The cyclic task means that the program will start on a fixed time-base that is synchronised with the drives own internal control loops. The time-base is selectable between 1 – 200ms.

SM-Applications Lite and SyPTLite offer a compelling alternative to traditional mini-PLC systems, in application where cost, foot print size or performance is important.

Note: SM-Applications and SM-Applications Lite can only be used with Unidrive SD.



Note: Full SM-Applications does not support SyPTLite programs.

SyPTPro – SYSTEM PROGRAMMING TOOLKIT

Overview

SyPTPro is the professional drive programming toolkit for OEM's and End Users who wish to maximise the performance of their machines and factory. This IEC61131-3 programming software offers greatly enhanced functionality allowing you to connect drives, Operator Interfaces and I/O to a network and configure how they exchange data. SyPTPro allow you to program in your choice of three different languages, with a real-time multi-tasking environment. It contains a suite of monitoring and diagnostics features that help you to reduce the time it takes to develop your programmes and allows you to get your machine into service faster.

SyPTPro may be used to program Unidrive SD with SM-Applications and SM-Application Lite option modules, and Mentor II DC Drive with MD29 option modules.



SM-Applications



SM-Applications Lite



MD-29

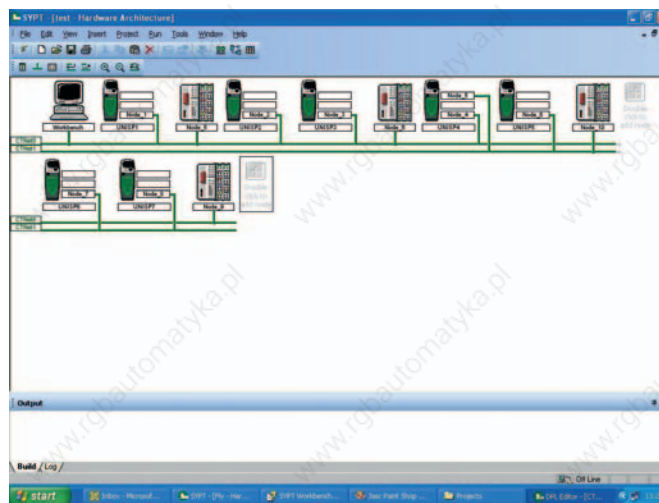

Industrial Network

SyPTPro allows you to configure a single drive or a complete drive system connected to a network. CNet is an industrial network designed to be deterministic, robust and tolerant to noise and interference. An OPC server is available free of charge from your local Control Techniques Drive Centre or Distributor.

Programming

SyPTPro allows you to program in your choice of three programming languages; these are Function block diagram, Ladder diagram and DPL (Drive Programming Language). And offer a multi-tasking environment where the tasks are scheduled according to the required speed of execution or triggered by events.

Function Block

SyPTPro incorporates an IEC61131-3 function block diagram editor, and comes with a library of more than 250 function blocks for both simple and complex functions. These embed years of application experience to make your software easier to write and easy to re-use. Additionally you can create a library of your own function blocks or update your library via our online user resources – SyPTPro.com. All function blocks may be used in any of the three languages.

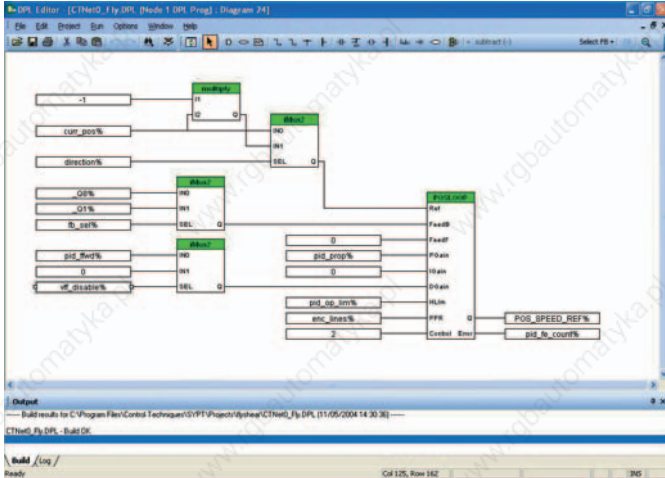

Ladder

SyPTPro incorporates an IEC 61131-3 Ladder language editor. This form of programming will be familiar to all PLC programmers and is the ideal format for sequencing and I/O control.

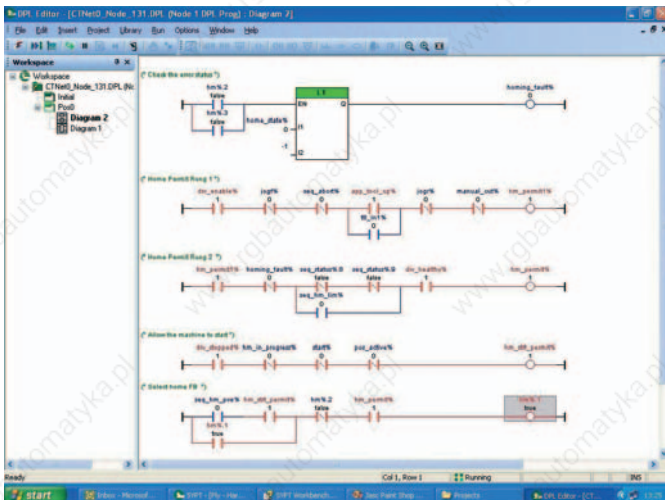

DPL

Drive Programming Language is a structured text language, as easy to use as BASIC, incorporating many standard constructs, such as IF, THEN, ELSE, and FOR, NEXT loops. DPL is ideal for initialising, configuration and general programming.

Diagnostics and Debugging

Good diagnostics are essential and ensure:

- Software development time is minimised
- Commissioning time is reduced
- Downtime is cut dramatically

SyPTPro contains a suite of diagnostic tools that help you to find problems with the system or software quickly and easily. When connected on-line, SyPTPro shows you live real-time views of variables in Function Block Diagrams, Ladder Diagrams and DPL, and allows you to execute program stepping and breakpoints.

System Watch Window

Allows you to monitor real-time variables and parameters form a single drive or multiple drives.

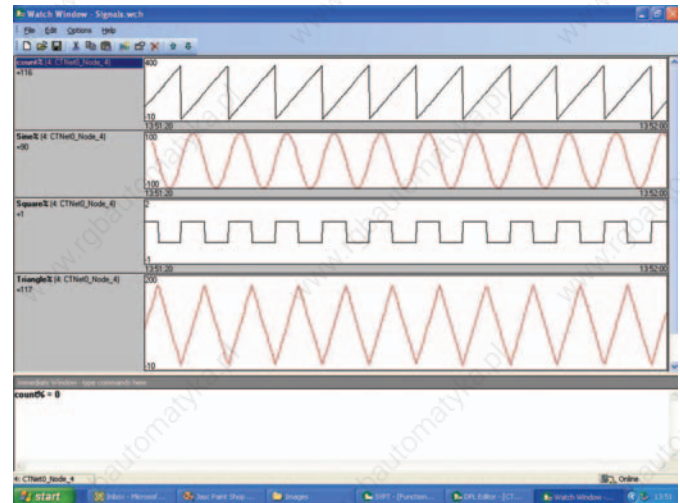

solutions

DUAL MODE WINDER

The Dual Mode Winder Application Software is the result of over 30 years of programming successful winder applications for a wide variety of materials and industries.

The term "Dual Mode" refers to the ability of the software to switch between torque and speed control modes, often a critical requirement in demanding applications such as high speed dual-turret, flying splice machines. The Dual Mode Winder Application Software supports over 95% of industrial winding applications.

The addition of a co-processor option module loaded with the Dual Mode Winder software provides a low cost flexible solution for a wide variety of winding applications.

Paper and Film Unwind and Rewinders

- Single or multi spindle
- Low tension high speed unwinds

Metal Coilers and Uncoilers

- Speed based control for thin strip with precise tension control
- Torque based control for heavy strip without tension feedback
- Speed/Torque control switching on the fly

Wire, Cable and Textile Spoolers

- Torque or speed controlled spoolers

Standard Features

- Torque Control Mode, including Constant Tension Centre Wind
- Speed Control Mode
- Dancer Feedback
- Load Cell Feedback
- Dancer Air Loading Output
- Line Speed Input
- Diameter Calculator
- Inertia Compensation
- Taper Tension - linear or hyperbolic
- Unwind/Rewind Selection
- Web Break detection
- Stall Tension adjustment
- Multiple Preset Diameters
- Jog
- Torque Memory
- All data entry done using Engineering Units

Accessories

- Fieldbus communication options: Modbus, DeviceNet, PROFIBUS DP, INTERBUS, CANopen, Ethernet and CTNet
- Expanded I/O option
- CTNet Modular I/O
- Range of HMIs
- Dynamic Braking
- Regenerative Braking

Solutions Software	Order Code
DualMode Winder	SSP-4000-0010

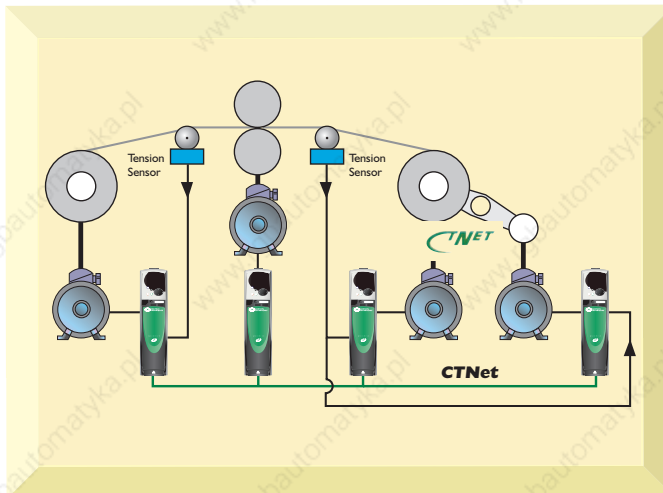



FLYING SHEAR CONTROL

The Flying Shear is a common industrial application for cutting a continuous product to a set length while at line speed. This means that the main production process is not interrupted, and so machine productivity is maximised.

Typical applications include various types of cut to length machines, depositors, punches, product inspection, or any other process where synchronisation at line speed is required.

Standard Features

- Easy configuration
- Hardware and software limits
- Manual jog functions
- Several homing modes
- High speed output is used to initiate the cut
- Registration capture
- Batch control functions
- Dynamic motion profile changes on the fly
- Engineering units are used for programming
- Units are defined for the master and slave axis as the number of encoder counts per unit. These are entered as a numerator and denominator to allow fractional values
- Resolution of the 'cut-length' may be entered to within 0.001 units
- Profile optimization reduces the machines mechanical stress: The return profile is calculated to operate at the slowest speed and acceleration rate, and yet with sufficient time to achieve the next cut, either triangular or trapezoidal profiles are used
- Parallel and angled carriage applications are handled

Flying Shear – Inline

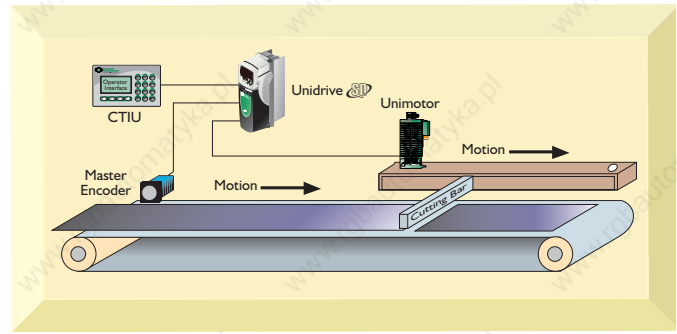

Flying Shear – Angled

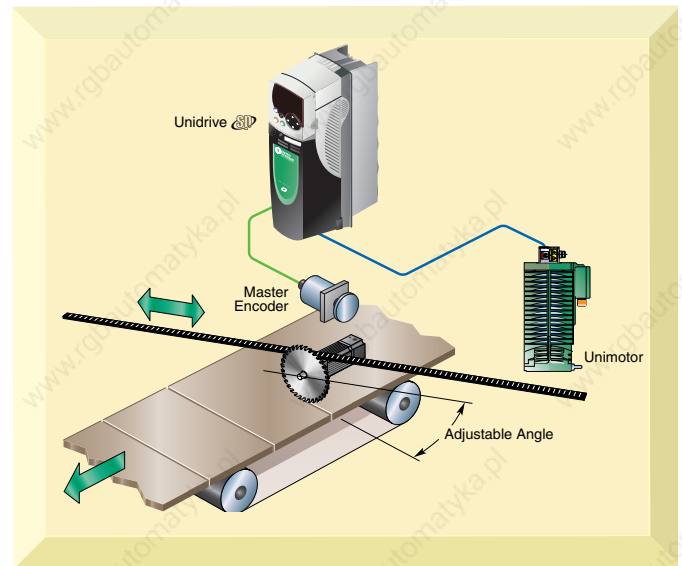

Solutions Software	Order Code
Flying Shear Control	SSP-4000-0020

Accessories

- Fieldbus communication options: Modbus, DeviceNet, CANopen PROFIBUS DP, INTERBUS, Ethernet and CTNet.
- Expanded I/O option
- CTNet Modular I/O
- Range of HMIs
- Dynamic Braking
- Regenerative Braking

solutions

FAN & PUMP DUTY ASSIST

The Duty-Assist control is an effective method of controlling multiple pumps or fans in parallel to maintain the required process demand. Pumps and fans are often used in parallel banks to avoid motor overload, guarantee security of supply through system redundancy, reduce running costs due to system load cycles, and provide a wide range of control and flexibility.

The system consists of a 'Duty' Drive and assist starters. The assist starters can be of any type, (e.g. Contactor, StarDelta, Auto-Transformer, Soft Starter or Inverter); the choice is dependent on the system limits. The Duty drive can control one dedicated motor (Fixed Duty), or with additional external switchgear could be selected to control other motors within the parallel configuration (Flexible Duty).

Standard Features

- Fixed Duty Motor – up to 4 Assist starters can be controlled
- Flexible Duty Selection – up to 3 Assist starters can be controlled
- Assist or Duty selection by Runtime (to ensure each pump/fan is equal used) or a set sequence
- Automatic reselection requested assist fails to start
- Local/Remote: Digital control from Unidrive terminal I/O or via fieldbus
- Standalone or system configurable
- Set-points and feedback can be derived as direct analog signals or by fieldbus

- 2 selectable process set points for use with day/night function
- Process High and Low trip thresholds (selectable)
- Inverse Speed characteristic (selectable)
- No Flow Protection (selectable)
- Wake/Sleep, Energy save function (selectable)
- Dynamic V/F, Energy save function (selectable)
- Cascade System Stop (selectable)

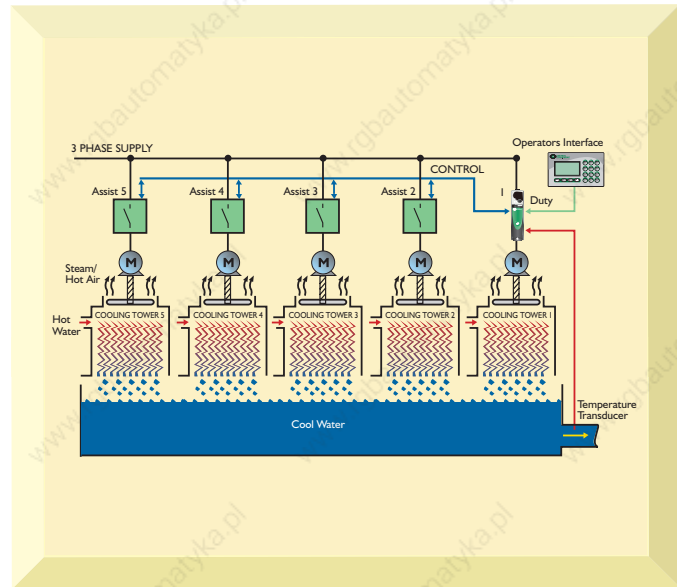

More Features

- Auto-changeover to ensure starters are not continually running for long periods of time
- Assists number of starts per hour protection (selectable)
- Assist Override delay to react to peak demands (selectable)
- All data entry for set-up in engineering units

Accessories

- Fieldbus communication options: Modbus, DeviceNet, PROFIBUS DP, INTERBUS, CANopen, Ethernet and CTNet
- Expanded I/O option
- CTNet Modular I/O
- Range of HMIs
- Dynamic Braking
- Regenerative Braking

Solutions Software	Order Code
Fan and Pump Duty Assist	SSP-4000-0030

POWERTOOLS PRO FOR UNIDRIVE AND SM-EZMOTION MODULES

The PowerTools Pro software in combination with the SM-EZMotion module enables you to fully realize the motion control power of the Unidrive . A familiar Microsoft® Windows™ interface provides operators and machine builders with the tools needed to access everything required for complete servo control – PLS, Queueing, Analog-In, User Variables, High-Speed Capture, Electronic Gearing, Multiple Profile Summation, S-Curve Accel and Decel, Program multitasking, Synchronized motion, and more.

Developing applications with PowerTools Pro is an easy “five-step, top-down” process that quickly gets your applications running. The five task areas that need to be completed in order are found in the Windows™ Hierarchy View – Hardware, Setup, I/O Setup, Motion, Programs and Network. Some areas may not need completing, as some applications, such as a “flying cutoff” may not require “programming” nor network parameters to operate.



- Programming software for the SM-EZMotion module that gets applications up and running quickly, from the simple to the complex
- Hierarchy View provides for an easy, flexible, and powerful programming environment
- Familiar Windows™-based processes simplify entering data
 - “Fill-in-the-Blank” Values “
 - Point and Click” Radio Buttons
 - “Scrolling” Menu Selections
 - “Drag and Drop” parameters and I/O assignments
- Online Watch window for diagnostic, fault, and parameter updates.



OR VISIT
www.controltechniques.com/download.htm

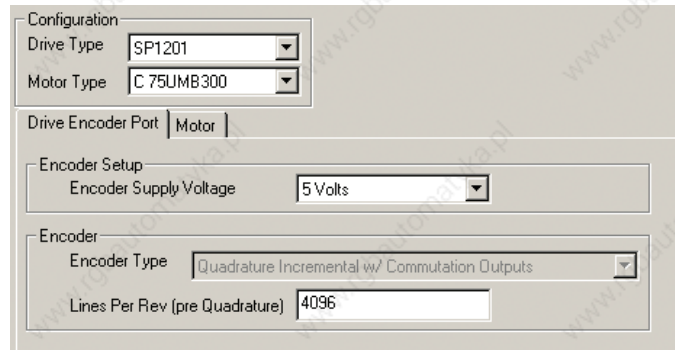

An unexpanded Hierarchy View is shown on the left-hand side of the SM-PowerTools startup screen.

User Units

User Units are the first item under Setup on the PowerTools hierarchy. User units deliver high resolution performance and ease of use. Motion can be programmed in any units that the user desires. Setup the 32-bit data resolution for position, velocity, and acceleration data one time and the rest is done for you. Select from optional time scales for Velocity and Acceleration units.

Programs

Combine program flow and motion instructions to create fully customised user programs up to 1,000 lines of code. Use conditional branching, wait for, program calls, formulas, user variables, and numerous motion instructions to solve your complex applications. Easily create programs, such as the drill head positioning program below, by dragging and dropping, or typing program instructions, variables, I/O, and formula operands into your program screen. Use the SM-EZMotion module to run one program at a time, or up to four programs simultaneously!

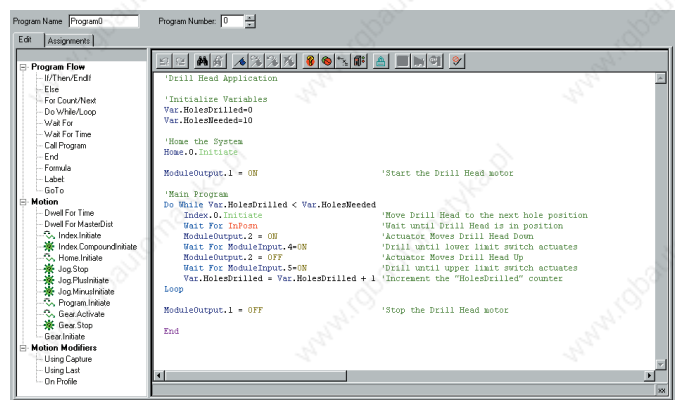

Expanded Hierarchy View

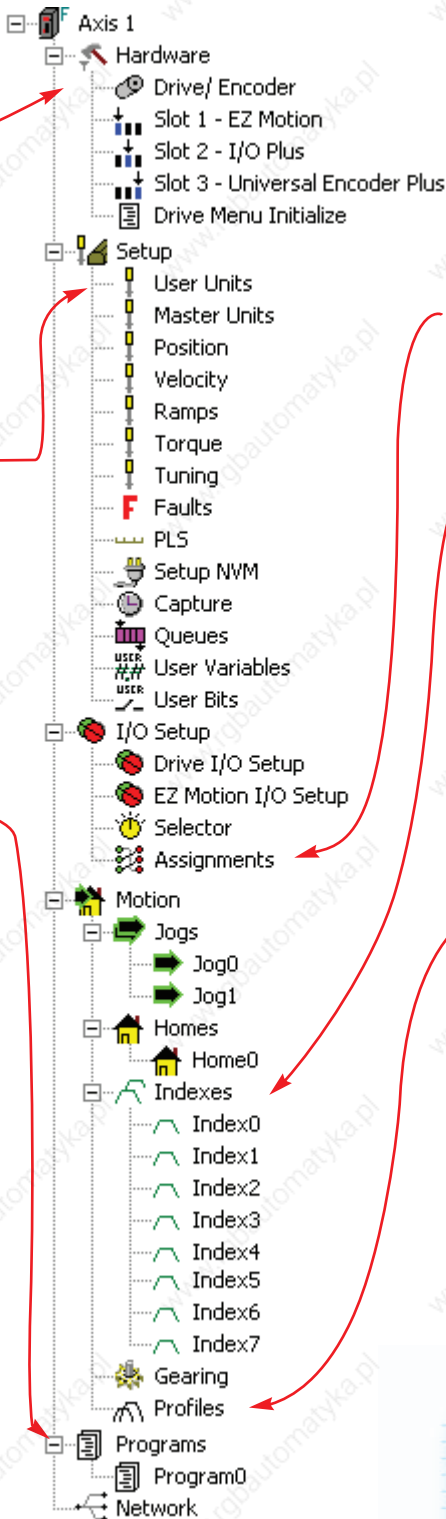

Source	Assigned to	Polarity	Destination	Set From	Polarity
InitiallyActive	PLS.0.PLSEnable	Active On	DriveOutput.1	Index.0.AVel	Active On
Index	DriveOutput.1	Active On	Index.0.Initiate	PLS.0.Status	Active On
Cut	Index.1.Initiate	Active On	Retract	Index.0.CommandComplete	Active On
PLS	Index.0.Initiate	Active On	Home	Home.0.Initiate	Active On
PLS0	Home.0.Initiate	Active On	Home0	Home.0.SensorTrigger	Active On
Inputs	Home.0.SensorTrigger	Active On	PLS	Home.0.SensorTrigger	Active On
DriveInput.1	Stop	Active On	PLS0	PLS.0.PLSEnable	Active On
DriveInput.2	MasterAxis.DefineHome	Active On	Ramps	Stop	Active On
DriveInput.3	Stop	Active On	Master	MasterAxis.DefineHome	Active On

Assignments

Use our "Virtual Wiring" to create programs right out of the box, without writing a "line of code." For example, the assignment screen below shows how easily a flying cutoff routine can be created.

Indexes

Setting up indexes is easily accomplished by filling in the screen's blanks to create an index profile. Select from Incremental, Absolute, Registration, or Rotary Plus and Minus types. Choose the time base of the index by selecting either realtime or synchronized to a master.

Start Position	0.0000	mm	Peak Velocity Attainable	2000	mm/m
Index Distance	50.0000	mm	Index Time	2.1000	Seconds
Accel Distance	3.3333	mm	Accel Time	0.2000	Seconds
At Velocity Distance	30.0000	mm	At Velocity Time	0.9000	Seconds
Decel Distance	16.6667	mm	Decel Time	1.0000	Seconds

Example Index screen

Profiles

This function allows the user to simultaneously execute any two motion types together resulting in a summed profile (i.e. Gear + Index, Jog + Index, Index + Index, etc.). Summing profiles is ideal for phasing applications such as Random Infeed, Rotary Knife, Merge Conveyor, and any number of other applications.

```

Gear.initiate on Profile.0
Index.0.Initiate on Profile.1
Wait for Index.0.CommandComplete
Wait for Time .25 'second
Index.1.Initiate on Profile.1
    
```

Multiple Profiling

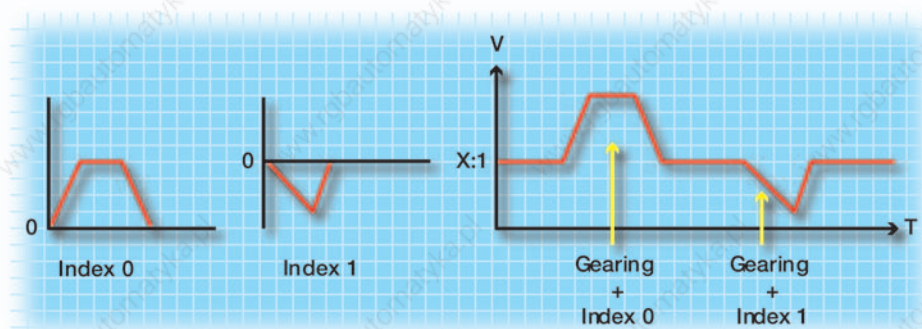

Automation Hierarchy Selection

Drive Integration Products

OVERVIEW

It is rare that an industrial drive stands alone in an application. In the majority of cases, drives are part of a system. As such it is necessary for the parts of the system to communicate with one another, transmitting commands and/or data. This communication can be in many forms from traditional analogue signals through to wireless communication systems. Control Techniques produced lower cost, higher performance drives, with good flexible and dynamic interfaces to other industrial products such as PLC's, HMI's etc.

The Automation Level in a Typical Factory

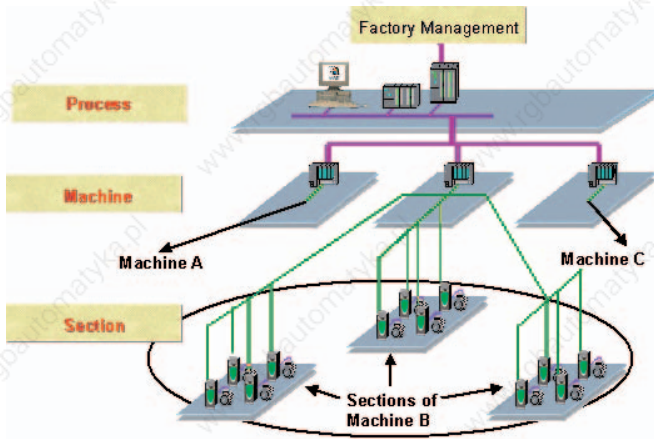

The figure above shows a typical factory IT/control hierarchy from a process control level down to sections of a machine. Drives are a part of the electrical system within a typical machine, yet the way machines have been controlled has been heavily influenced in recent years by the growing capabilities of drives.

Traditionally systems have been controlled by powerful Centralised Controllers at the Process Level. As the cost of PLC's reduced, control was distributed to the Machine level. As PLC's continue to fall in price, further distribution of control is happening. However the threat to PLC's in this role comes from drives which have considerable processing power, and direct contact with much of the critical variables of the system thereby offering new opportunities in terms of optimised system control.

In all applications it is worth considering the relative benefits of Centralised and Decentralised Control. This assessment needs to be done prior to deciding on the most appropriate fieldbus for the application.

CENTRALISED CONTROL SYSTEMS

Centralised control requires a powerful Machine Controller, (usually a PLC or PC) with centralised programming and configuring software tools to provide:

- Gateway to the process layer
- Machine co-ordination and sequencing
- Machine real-time control algorithms for one or a number of devices (including drives)
- A high speed and medium bandwidth communication system and/or support a lot of inputs and outputs for plant based devices
- Service data to and from devices

The communication throughout the system is via the machine fieldbus Local Area Network (LAN). The dynamic speed of such a network depends not only on the choice of fieldbus, but also on the number of nodes connected. Great care is needed in specifying such a system if the system requirements are not to be compromised. The specification of such a network is the most common problem during system commissioning, and can be responsible for some serious project delays.

A typical configuration for a centralised control system is shown below.

Typical Centralised Control System

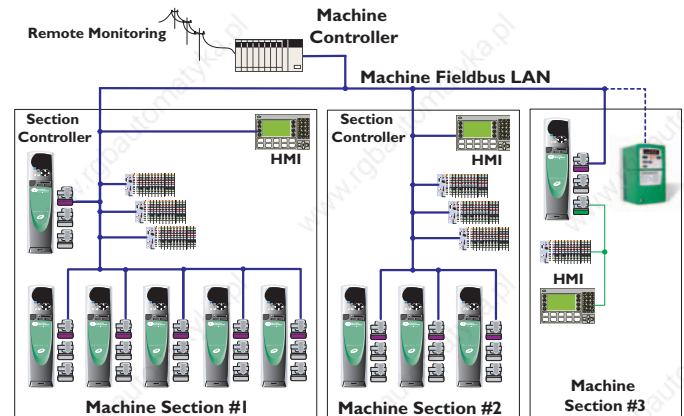

Advantages:

- Simple architecture
- One learning curve for programming and configuration tools
- Efficient, one point bridge to process layer
- Usually a lot of applications support available from controller suppliers and integrators

Disadvantages:

- Expensive hardware and software (Machine Controllers are expensive on large systems and software tools)
- The central controller is a commissioning bottleneck
- Redundancy is very expensive to build in
- A broad family of controllers needed for cost effective adoption across a factory

DECENTRALISED CONTROL SYSTEMS

This alternative approach is also referred to as a Distributed Control System. This requires:

- Peer to peer communications (devices to talk with one another)
- "Intelligence" in some devices
- A gateway to support the Process layer interfaces
- A common and flexible programming, configuration, commissioning and visualisation software tool

Advantages:

- Low cost
- Small control panel size
- Easier design and maintenance – Modular software
- Opportunity for faster response times than with centralised control (Better Performance)
- Inherent system redundancy possible
- Multi-commissioning access reduces set-up time
- No machine controller
- Modular software readily facilitates re-use
- System is scalable

Disadvantages:

- Needs high level commissioning and programming tools (Need to realise sections and device functions)
- Gateway to Process layer required
- Process layer can access all machine devices (no filtering)
- High degree of system determinism may be required
- High system communication bandwidth may be required

Fully Decentralised Control

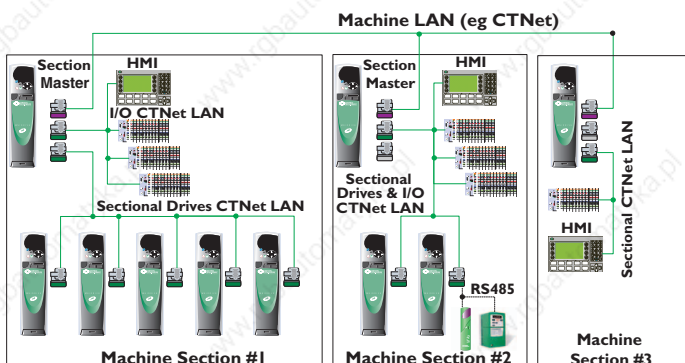

HYBRID CONTROL SOLUTION

A Hybrid solution, sometimes known as Distributed Sectional or Cluster Control, is now receiving significant attention.

This requires:

- A medium processing power Machine Controller to provide:
 - Gateway to the Process layer
 - Machine co-ordination and sequencing
 - Support a lot of system inputs and outputs (digital and analogue) – High Speed and medium bandwidth to and from each section
- A medium processing power Sectional Controller to provide:
 - Gateway to the Machine controller
 - Section co-ordination, sequencing and if necessary synchronisation
 - Support a lot of system inputs and outputs (digital and analogue) – High Speed and medium bandwidth to and from each section. Service data to and from each device
 - Master-Slave or Peer-Peer architectures can be adopted
 - Common programming, configuration and commissioning software tools

Hybrid Control (Distributed Sectional Control)

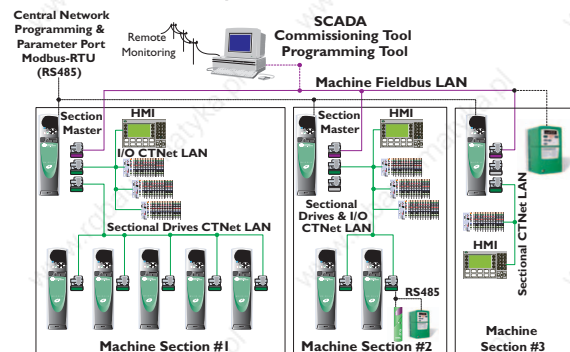

Advantages:

- Very cost effective solution for medium/large systems
- Simple architecture – each section controller is responsible for its own sectional devices
- Efficient, one point bridge to the Process layer
- Modular software – Easier development, maintenance and re-use
- Common server and marshalling
- Inherent sectional redundancy
- Multi-commissioning access
- Tight control with fast updates for Sectional control
- Common programming and commissioning software

Disadvantages:

- Potentially higher cost for small systems
- Without common software tools, (Machine and Sectional) system visibility is restricted – solved with **SYPTPro**

Having looked at these system implementations the opportunities for 'solutions platform' drives emerges. No single control configuration can be considered "the best" for all occasions the driving factor is the application itself. In the illustrations, there is not a wide proliferation of PLC's, indeed their absence is striking. In the decentralised and hybrid solutions however, there is a considerable requirement for decentralised "intelligence", and this is contained within Unidrive **SD**. The capability of the Unidrive **SD** to undertake real-time control functions is critical. For example a winder-unwind controller may need to be embedded or a complete elevator control including call handling, speed / acceleration ramps, positioning etc. Windows™ based software tools (based on IEC61131-3) makes programming, commissioning and maintenance a straight forward task for operators familiar with PLC programming.



In all solutions, the need for the Unidrive **SD** to support modern high speed fieldbus communications is implicit.

In the hybrid solution, the drive acts as both a communications bridge (linking the Machine fieldbus LAN to the Sectional LAN) and as the Sectional controller. It also provides a further LAN to interface with the Sectional I/O. Further sub-LANs are also illustrated. This layering of LANs greatly simplifies the communications network and leads to great benefits in terms of system performance and visibility. The design is simplified by breaking the tasks into modules. This modular design lends itself to the important practice of re-use both of software but also hardware.

System performance is enhanced by tight synchronisation of control loops and between the Unidrive **SD** and its option modules.

Example of Decentralised control

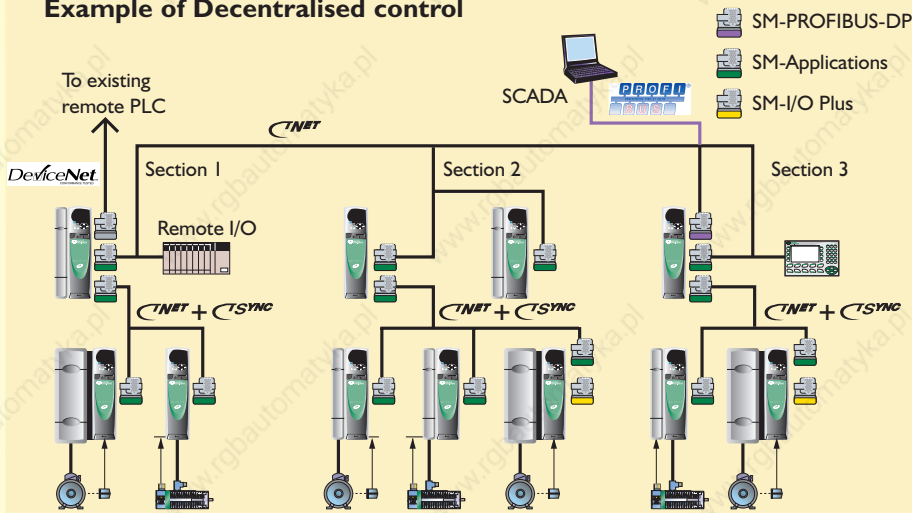

ULTIMATE FLEXIBILITY

The flexibility of the Unidrive **SD** together with the option module range makes the Unidrive **SD** the perfect Solutions Platform for any automation system.

The SM-Applications option modules can be used in almost unlimited combinations with fieldbus and I/O options in order to neatly dovetail into existing automation systems.

Alternatively, when starting out with a clean sheet of paper, the Unidrive **SD** can achieve the necessary cost and space savings by allowing the Project Engineer to accurately match the PLC and I/O requirements.

CTOPCserver

VISIBILITY – FROM THE BOARDROOM TO THE FACTORY FLOOR

OPC can be compared to your printer drivers in Windows™. The printer drivers allow the windows software to use any type of printer made by any manufacturer provided a valid driver is supplied with the product. Similarly OPC allows your industrial software that supports OPC to communicate with any industrial equipment provided the manufacturer can supply you with valid OPC Server software. In addition multiple OPC servers may be installed in your system allowing your software to communicate with different devices from different manufacturers. OPC was developed in conjunction with Microsoft and as a result software tools such as Excel, Visual Basic, Visual C++ etc can make use of OPC, however, because of the obvious advantages of OPC, it's major success has been within SCADA systems and now all major suppliers of industrial SCADA Software supports OPC as standard.

Control Techniques are long standing members of the OPC foundation, our OPC server is available free of charge and supports communication with a single drive or a network of drives using either CTNet, Ethernet or the standard RS485 communications available on the drive.

This diagram shows how OPC can provide visibility of the drive system from the board room to the factory floor.

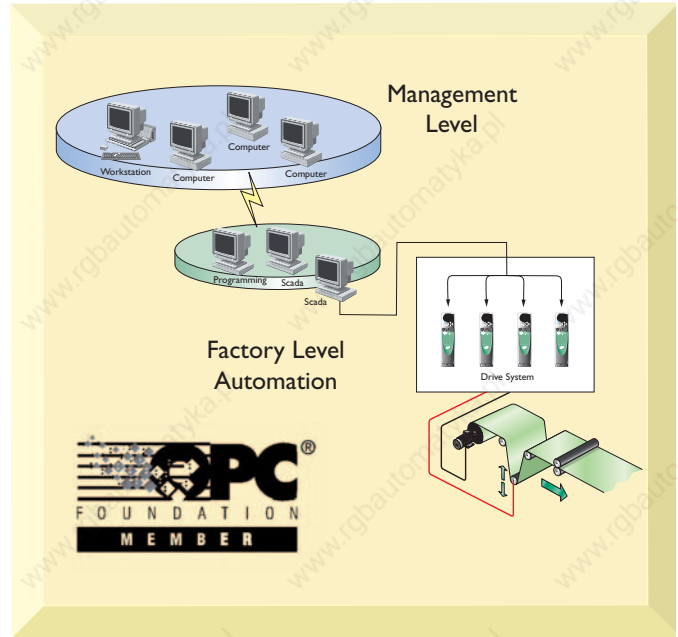

OPCserver SOFTWARE IS PROVIDED FREE, DOWNLOAD FROM www.controltechniques.com/download.htm



NETWORKING COMMUNICATIONS

CTNET Drive Integration Products

DECENTRALISED CONTROL SOLUTION

CTNet is a comprehensive line of equipment enabling the design engineer to create high performance and cost effective decentralised control solutions. The CTNet product range supports intelligent co-processors installed in Control Techniques' AC and DC drives with a high-speed peer-to-peer fieldbus that enables the control set up required by an application distributed.

At-A-Glance

Function	Description	Order Code
Application Co-processor Modules	Includes CTNet fieldbus connections and Co-processor	SM-Applications (Unidrive ) MD29AN RevD * (Mentor)
Network Accessories	3 port Hub, provides connectivity to 3 CTNet segments	CTNet-Hub-RevD*
	Fibre Optic Repeater	CTNet-FIB-RevD*
	3 port Hybrid Hub, for connectivity between current and previous CTNet versions	CTNet-Hybrid Hub
	CTNet bulk cable	CTNet-xxx
PC Network Cards	For use with Laptop Computer	CTNet-PCMCIA-RevD
	Desktop Computer (w/PCI bus)	CTNet-PCI-RevD*
	Desktop Computer (w/ISA bus)	CTNet-ISA-RevD*
Remote I/O	Beckhoff bus coupler	SSP7200-RevD
HMI Display Operator Interface	Operator Interface Unit	CTIU200
	CTNet comms card	CTIU200-CTNet-RevC
Application Programming Software	Systems Programming Toolkit 	
Power Supply	24VDC Power Supply	Consult Drive Centre
Network Bridges	Bridge between CTNet and DeviceNet, PROFIBUS DP, INTERBUS, Modbus, Sercos, Ethernet and CANopen	Unidrive  (Gateway Feature)

*CTNet components sold prior to January 2003 utilise a different product revision than shown above, Rev D. Please contact Control Techniques when purchasing components for older installations.





OVERVIEW

The CTNet fieldbus is a 5 Mbit token ring network that supports peer-to-peer communications. Utilising the field-proven ANSI/ATA 878.1 ARCNET standard as a foundation, CTNet includes a custom protocol stack that supports cyclic data and non-cyclic "one shot" transactions. The CTNet fieldbus employs an RS485 transformer-isolated physical layer to allow usage of a convenient and inexpensive two-wire shielded, non-phasic cable.

Two methods of data exchange are supported: cyclic data and non-cyclic data. Cyclic data exchanges are pre-programmed block transfers (20 registers max.) between co-processors at either a fast or slow rate. Non-cyclic exchanges are asynchronous transfers initiated by application programs or SCADA / HMI devices.

APPLICATION CO-PROCESSOR MODULES

SM-Applications / MD29 / MD29AN

Control Techniques Unidrive  AC drives / Mentor DC drives accept plug-in co-processors modules as a standard accessory. SM-Applications (Unidrive ) and MD29AN and MD29 (Mentor) plug-in co-processors include the CTNet high-speed peer-to-peer fieldbus to allow the modules to communicate with one another.

The CTNet-equipped co-processors are based on a high performance microprocessor with up to 384 Kbytes of program storage and 80 Kbytes of variable storage for user applications. In addition to the CTNet fieldbus, serial ports are available for RS485 communications. The co-processors also include a built-in counter-timer unit and a position controller capability.

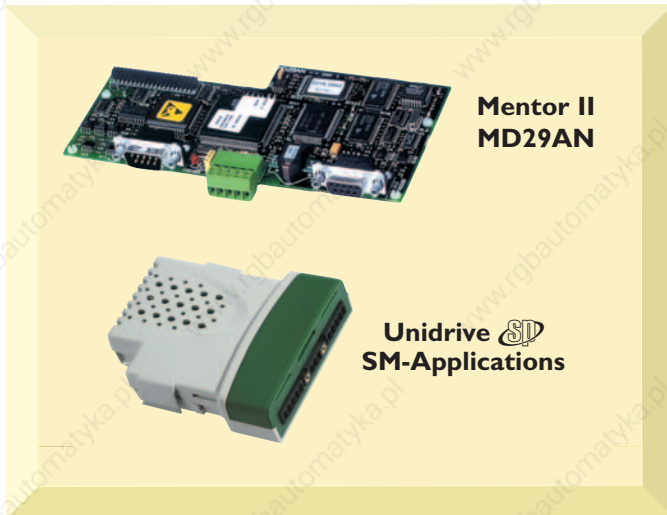

PC NETWORK INTERFACE CARDS

For desktop and laptop computers, there are three types of CTNet network cards. All cards permit user specification of the node address, baud rate and IRQ (where applicable).

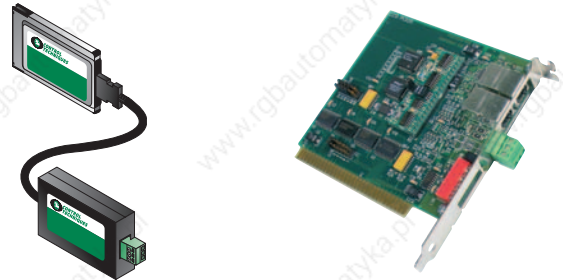

Network Application Card	Order Code*
Laptop Computer	CTNet-PCMCIA-Rev D
Desktop Computer w/PCI bus	CTNET-PCI-Rev D
Desktop Computer	CTNet-PCMCIA-Rev D

*CTNet components sold prior to January 2003 utilise a different product revision than shown above, Rev D. Please contact Control Techniques when purchasing components for older installations.

NETWORK ACCESSORIES

Repeaters

For extending CTNet cable segments and creating star topologies, there are three types of repeaters available:



Description	Order Code
Two-output (3-port) Repeater (Hub)	CTNet-Hub-Rev D
Twisted-pair to Fibre Optic Repeater	CTNet FIB-Rev D
Hybrid Hub for connecting previous versions of CTNet hardware to current versions	CTNet Hybrid Hub

CTNet Cable

Control Techniques supplies a high quality shielded twisted-pair cable suitable for high-speed data transmission. It is available in three standard lengths or any specified non-standard length.



Cable Length	Order Code
100 metres	CTNet-100
200 metres	CTNet-200
Non-standard (bulk in metres)	CTNet-xxx*

* xxx= number of metres

REMOTE I/O

The high-quality Beckhoff I/O system is available for CTNet systems.

Beckhoff systems for CTNet include a bus coupler and a large variety of snap-on terminal blocks allowing up to 256 digital inputs or outputs and up to 100 analog inputs and outputs per bus coupler. Up to 64 Beckhoff I/O systems can be attached to a CTNet network. I/O points can be easily read or written. Contact Control Techniques for details on the wide range of available Beckhoff Remote I/O options.



HMI OPERATOR INTERFACE

Control Techniques supports several HMI displays, and of these the CTIU200 model, with the CTIU200-CTNet-Rev C option, supports CTNet operations. The CTIU200 is a high-end operator interface unit featuring a 16-line, 40-character display, 37 keys, 300 pages of user-programmable displays, a scripting language, graphical charts and trends, recipe support and user-friendly modification of parameter values. A sophisticated Windows programming tool creates the custom application and downloads it into the CTIU200 for operation.



SyPTPro SYSTEM PROGRAMMING TOOLKIT

● Auto Detection

When SyPTPro is connected to your drive system it will:

- Automatically interrogate your network
- Discover which components are connected
- Let you upload to the PC the software from the option modules

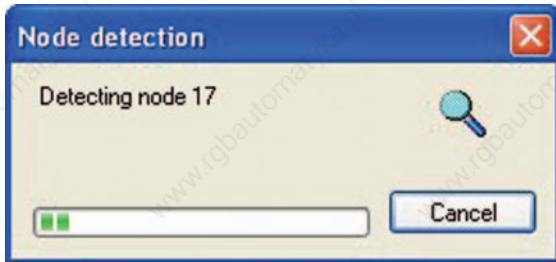

● Simplicity of Connection

SyPTPro may be connected via a CTNet PC card direct to the CTNet network or through the standard RJ45 programming port on the drive. In both cases you get total visibility of the complete CTNet network for programming and diagnostics.

● Multiple - CTNet Networks

For the ultimate multi-tasking and multi-processing fit multiple SM-Applications modules to your Unidrive SD, this allows you to increase the processing power where required, and support multiple CTNet networks in a system. Even if you do not need to now, it is reassuring to know that you can expand your drive system to incorporate any future modification.

● Multi-point Programming

More than one SyPTPro programming station may be resident on a CTNet network allowing work to be done on different parts of the system simultaneously and so allowing commissioning times to be minimised.

Further information on SyPTPro can be found in Section 10.1

POWER SUPPLY

A 24VDC power supply with an output rating of 600 mA is ideally suited to provide power for various Control Techniques accessories. Some of these accessories include the various CTIU operator interfaces, CTKP and Beckhoff I/O.

Typical Specifications

- 100 to 240 VAC 50/60 Hz input power
- 600 mA max. output current
- IP20 rated enclosure
- -10 to 60°C operating temperature
- Panel or Din rail mounting
- UL/cUL, UL508, CE marked, TUV



NETWORK BRIDGES

The Unidrive SD provides unrivaled fieldbus flexibility. In addition to the standard Modbus RTU port, up to three fieldbus option modules can be installed in the Unidrive SD's option slots. This provides the capability to control and monitor a Unidrive SD on multiple fieldbus networks. For example, a single Unidrive SD can be configured to communicate on both DeviceNet and PROFIBUS networks simultaneously.

In the example shown, CTNet is used to provide real-time co-ordination between two Unidrive SD modules. The DeviceNet and PROFIBUS connections allow data to be passed to the controllers in a machine line.

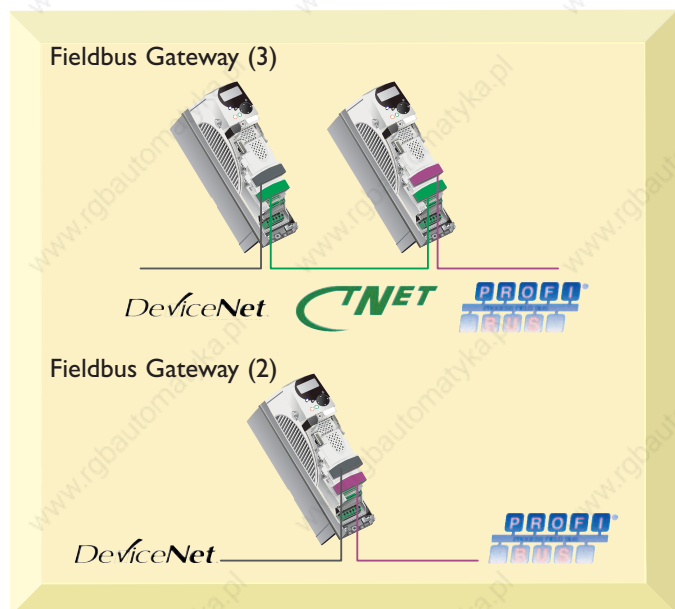

Fieldbus

OVERVIEW

The term fieldbus is a generic one that covers all of the current communication bus systems including PROFIBUS, INTERBUS, CANopen, DeviceNet, Ethernet, Sercos and Control Techniques' own CTNet system. All of these are digital communication systems that allow a control system to exchange data with remote sensors, actuators and drives using a single communications link.

The major benefits are reduced installation, cabling and maintenance costs with more reliable and flexible operation.

Selecting the right fieldbus?

If you take away the purely political dimension of what bus system appears to be in favour or in the ascendancy at any one time, then the major determining factor is whether the system would benefit from a centralised or decentralised control strategy. Having selected the choice of machine control there still remains a multitude of bus systems to choose from. Many factors continue to influence such as network topology, data rates and range of supported devices.

This demonstrates Control Techniques' open approach to all the leading fieldbuses and its flexibility in terms of customer's choice of control strategy. The balance of this chapter is devoted to giving users a balanced overview of the benefits and appropriateness of the leading fieldbuses. It is based around the fieldbus options for Unidrive

PROFIBUS-DP

PROFIBUS-DP is a high speed communications network and protocol, that allows large amounts of data (up to 12MB/s) to be transferred quickly to and from network nodes. The PROFIBUS-DP interface detects the network data rate, and automatically synchronises to it. PROFIBUS-DP systems are centralised with a master controller controlling all communications with slave nodes on the network.

Terminal Information for Unidrive			
Cable	Function	Function	Description
Red	RxD/TxD-N	3	Positive data line
Green	RxD/TxD-P	8	Negative data line
Braided Shield	Screen	Shell	Cable screen

DeviceNet

DeviceNet is a high speed communications network protocol that uses the Controller Area Network (CAN) hardware layer and signalling. DeviceNet networks require a master controller, usually a PLC "scanner" or PC, with all network communications controlled by the master device.

The DeviceNet Interface complies fully with the DeviceNet architecture, performing as a slave node only. It does not support "peer-to-peer" communications. Data rates from 125 Kbits/sec up to 500 Kbits/sec are supported.

Terminal Information for Unidrive			
5-Way Terminal	D-Type Terminal	Function	Description
1	6	0V	0V external supply
2	2	CAN-L	Negative data line
3	3,5 shell	Screen	Cable braided screen connection
4	7	CAN-H	Positive data line
5	9	+ 24V	+ 24V external supply

INTERBUS

INTERBUS networks are "centralised" systems, requiring a master controller (usually a PLC) which controls all communications with slave nodes on the network. The INTERBUS interface enables the drive to function as these network nodes, with the advantage for users that it does not require any change to its default setting to operate on a configured network. The master controller scans the network during network initialisation, and assigns addresses to each node depending on their physical location on the network. The data rate for INTERBUS is fixed at 500 Kbits/sec.

Terminal Information for Unidrive			
Cable	Function	Function	Description
Red	RxD/TxD-N	3	Positive data line
Green	RxD/TxD-P	8	Negative data line
Braided Shield	Screen	Shell	Cable screen



CANopen **CANopen**

The CANopen interface has been tested and awarded full Product Conformance Certification by CiA (CAN In Automation), the controlling body for CANopen. Conveniently, the CANopen interface is configured as a slot-in card to the interface module which gives the Unidrive its unrivalled flexibility in high level control and communication systems.

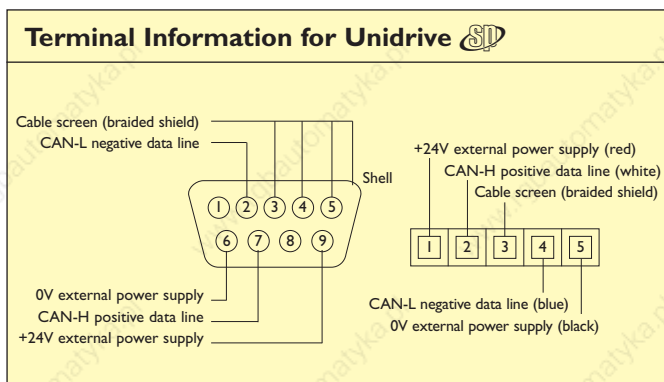
The CANopen interface enables OEMs and users to harness the comprehensive facilities of CANopen for use in industrial automation systems where Unidrives may be called upon to network with other CANopen compliant “intelligent” devices such as sensors and actuators. It allows process data to be regularly updated in remote network nodes, and removes the need for extensive digital and analogue I/O wiring. Supported data rates for CANopen range from 10 Kbits/sec to 1 Mbit/sec.



CAN INTERFACE

The Unidrive  SM-CAN interface allows any CAN protocol to be implemented for Unidrive using DPL (Drive Programming Language) code or the Function Block Editor within  (System Programming Tool). Function blocks are available for the  Workbench that provide full access to the CAN data link layer, and allow configuration of the CAN controller from the DPL program.

Due to the way CAN works, it is ideal for designing and implementing networks with “peer-to-peer” communications, where nodes are allowed to transmit data over the network at data rates from 10kbits/sec to 1.0 Mbits/sec, without the need for an overall master controller.

The CAN controller used in the Unidrive  CAN module has full message filtering features built in, which allows the CAN controller to filter out unwanted messages, thus reducing the loading on the CPU.

UNIDRIVE INTERFACE

Highly deterministic distributed control

Control Techniques CTNet interface enables users to leverage the facilities of the Unidrive V₃, Unidrive  and Mentor; Applications co-processor modules, for real time decentralised control. CTNet was developed specifically for highly dynamic applications, over trunk lengths generally exceeding 100m, using proven token ring data link technology. CTNet is a “decentralised peer-to-peer” system, requiring no master PLC controller; with each intelligent node taking its turn to control the network, and communicate directly, and in real-time, with other network nodes at data transfer rate of up to 5Mbits/sec.

CTNet supports up to 255 nodes and provides an intelligent drive-orientated approach to systems integration based on decentralised control, universal communications and graphical software. Unidrive  enables a CTNet gateway to industrial networks such as PROFIBUS-DP, INTERBUS, DeviceNet, Ethernet and Sercos.

SERCOS Interface

The SM-SERCOS module is class B compliant, supporting the torque, velocity and position control modes. Also supports probing cycle additional functions (Position registration) and user-defined telegrams.



The SM-SERCOS module is configurable through Unidrive  parameters – there are no hardware configuration switches.

The SM-SERCOS module uses the standard fibre optic ring topology, using standard transmit and receive optical connectors.

- All SERCOS baud rates supported – 16Mbps (Default), 8Mbps, 4Mbps and 2Mbps.
- Network cycle times supported: 250µs, 500µs and 1 to 65ms (In 1ms increments).
- Four optical power levels are available for transmission, and it is possible to disable the network repeater in the module (breaking the network at that point).
- Provides two freeze inputs used for SERCOS probing cycle functionality.

Additional Features

User-defined application telegram (Type 7) is supported. This provides the facility to specify a list of IDNs to be transmitted in the Amplifier Telegram (AT) and Master Data Telegram (MDT).

Additional IDNs that allow data on the drive operating status to be obtained, for example, the DC bus voltage or the power stage temperature.

The Probing Cycle procedural command allowing the current feedback position to be latched upon the occurrence of a configurable condition; a negative or positive edge on the probe input. The module has two fast digital probe inputs dedicated to this purpose.

SM-Ethernet

Ethernet is growing quickly as a network for industrial automation, the SM-Ethernet module allows Control Techniques drives to enjoy the benefits of a high-speed Ethernet network and global connectivity.

SM-Ethernet Connections

Terminal Information

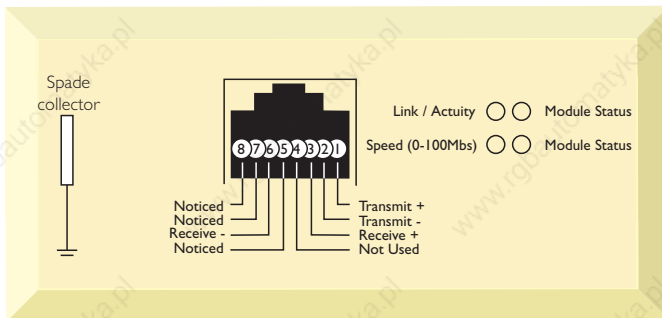

SM-Ethernet Connection Description

The module uses a standard RJ45 connection, supporting both unshielded and shielded connectors. There is also an additional earthing tag for supplementary earth bonding.

SM-Ethernet supports the following connectivity features:

- 10 / 100 Mbits/s auto-negotiation
- Auto-crossover detection
- Auto duplex setting

The features supported by SM-Ethernet are:

• Modbus TCP/IP protocol

Modbus TCP/IP is a standard industrial protocol that has become popular for industrial Ethernet connectivity between devices such as HMI's and PLC's. Control Techniques software products may also use Modbus TCP/IP for connection to drives allowing CTSoft, SyPTPro and our OPC server to connect over Ethernet. A major additional benefit is that several Modbus TCP/IP devices may communicate with the same SM-Ethernet option module simultaneously.

• HTTP Web Server

The SM-Ethernet module contains a range of standard web pages for monitoring, diagnostics and configuration, in addition, user defined web pages may be downloaded to the drive giving you the option to create a graphical user interface unique to your application.

Homepage showing the general configuration and status of the drive

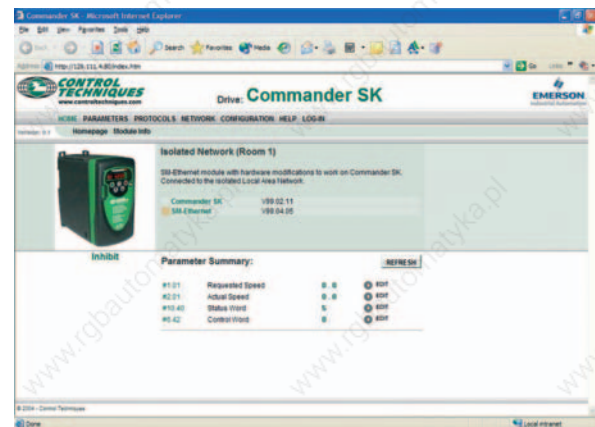

Protocol Configuration

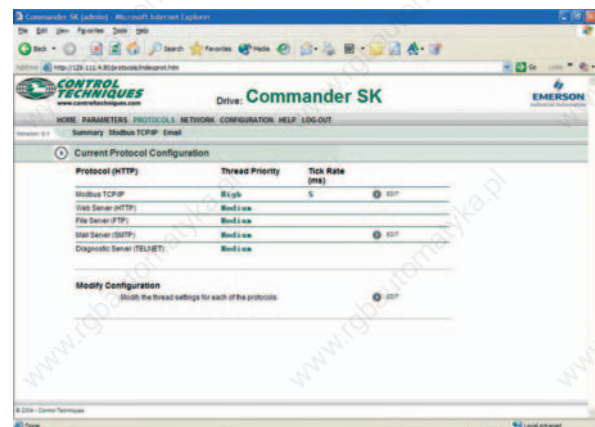

Examples of SM-Ethernet user defined web pages.
The controls may be re-used to create your own unique web page for your specific application.



● **SMTP Mail**

SM-Ethernet may be configured to generate emails allowing the drive to signal the drive status or alternatively a more advanced function such as send an email to the engineering department to inform that a component in a machine is due for replacement as part of a preventative maintenance cycle.

● **DHCP**

DHCP means Dynamic Host Configuration Protocol. This protocol is used to manage the IP addresses assigned to devices on an Ethernet network. As new devices join an Ethernet network, a DHCP server assigns an address for that device to use. This means that the address is dynamic, in other words each time a device is powered up it may be assigned a new address. SM-Ethernet optionally supports DHCP, allowing the drive to join a network where a DHCP server is present, however, for many industrial networks DHCP is not used as having a fixed, Static IP address can be an advantage in locating and managing devices.

● **FTP and TFTP**

FTP means File Transfer Protocol and TFTP means Trivial File Transfer Protocol. SM-Ethernet uses this protocol for uploading and downloading drive parameter files, firmware and web pages.

● **Auto-negotiation**

SM-Ethernet supports 10Mbps and 100Mbps, Auto-negotiated means that on initialisation the speed of the connection is automatically negotiated/detected.

● **Auto-crossover**

Auto-crossover on SM-Ethernet is able to auto detect if the Tx/Rx connections are crossed over and on initialisation set the module to suit the incoming connection.

Ethernet patch leads are available as direct 1 to 1 connections or cross over connection.

Direct patch leads are typically used for:

- PC to Switch/Hub
- SM-Ethernet to Switch/Hub

Crossover patch leads are typically used for:

- Switch to Switch
- PC to SM-Ethernet

Remote Connectivity

Direct dial-up connection

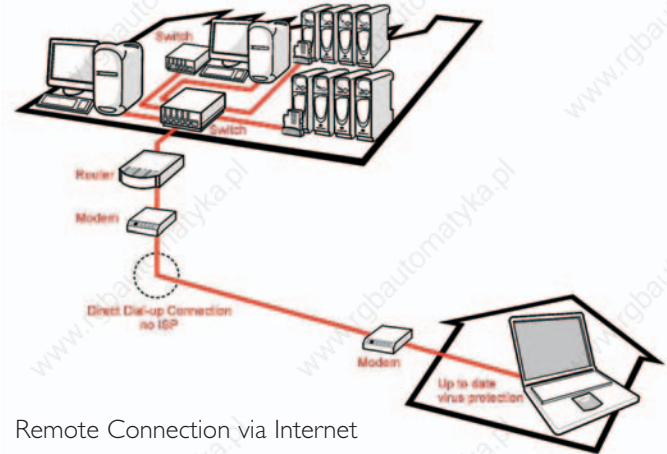

Remote Connection via Internet creating a Virtual Private Network (VPN)

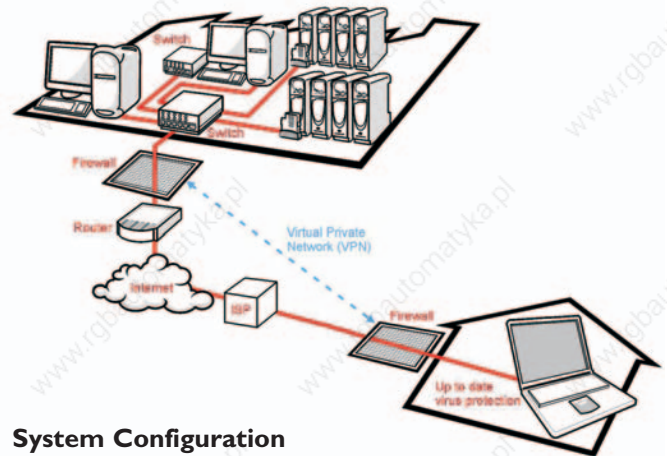

System Configuration

Communications Protocol	Interface Module Order code	System Configuration
Modbus RTU*	SM-Applications	Master/Slave
PROFIBUS-DP	SM-PROFIBUS-DP	Slave
INTERBUS	SM-INTERBUS	Slave
CTNet	SM-Applications	Peer-to-Peer
DeviceNet	SM-DeviceNet	Slave
CANopen	SM-CANopen	Slave
CAN Interface	SM-CAN	Master/Slave
SERCOS	SM-SERCOS	Slave
ModbusTCP/IP	SM-Ethernet	Slave
SMTP Mail		Slave
FTP File transfer		N/A
SLM	SM-SLM	Slave

* Modbus RTU is standard. An additional Modbus RTU port can be provided with an SM-Applications module.

Operator Interface

OPERATOR INTERFACE OPTIONS

Control Techniques has set up a partnership with two major operator interface manufacturers, Horner and ESA. This partnership gives users access to the widest possible range of units to ensure that you get right interface to suit your needs at the right cost. Both of these companies are technology leaders, where designing and manufacturing the most innovative range of operator interfaces are core competencies. Both of these companies' products are available through your local Control Techniques Drive Centre/ Application Centre or Distributor.

Horner Advanced Products Group

Horner is a global company designing and manufacturing a wide range of text, graphical and touch-screen operator interfaces. These are programmed with the powerful and yet easy to use CBreeze software, where 'what you see is exactly what you get'.

Horner products may be used with Commander SK, Unidrive SP and Mentor II, and support Modbus RTU, direct CTNet connectivity and CTNet Modbus function codes (See Below).

The TIU offers a wide range of communication operator interface products spanning from 2 lines text to 12.1" SVGA colour touch screen. With its downloadable protocols it is able to communicate with a wide range of devices ranging from drives to PLC's via bar code readers and other serial devices. Fieldbus options such as CTNet, Profibus DP and DeviceNet are also available.

Here are some example products from Horner:



CTIU 200

Colour-Touch TIU300 Series



The TIU 300 series offers Monochrome and Colour-Touchscreen capability in 5.7" sizes in both STN and TFT with 1/4 VGA (320 x 240 Pixel) resolution.

All Units have 1 off RS232/RS422 and 2 off RS232/485 ports, 5 Function Keys and a mini centronics port.

The Monochrome unit has 8 Hues and Colours Units have 16 Colours.

Colour-Touch TIU500 Series

TIU's are available with 800x600 Pixel resolution in 8.4", 10.4" and 12.1". All screens have over 32,000 Colours and have High Brightness and Wide Viewing Angle.



All units Include Ethernet, Compact Flash, 3 off RS232/485 Serial Ports, Function Keys and are rated IP65 from the Front Panel.

ESA Elettronica S.p.a

The company has now grown to one of the world's major producers of HMI's. The VT range of operator interfaces offers an extensive selection, from small 2 line text displays through to full Windows™ CE and Linux based terminals. Most of the units are programmed using the VTWin software tool providing the functionality required for your application. ESA operator interfaces offer great value and functionality. ESA Products may be used with Commander SK and Unidrive SP and support Modbus RTU and CTNet Modbus Function codes (See Below). Some ESA panels also support Ethernet Modbus TCP/IP master.

VT155W

Operator terminal with 4", graphic LCD display, 4 tones of gray, 16 rows by 40 characters (240 x 128), Touch-Screen, 640 KB project, clock, 16 KB recipes.

May be mounted either horizontal or vertical.

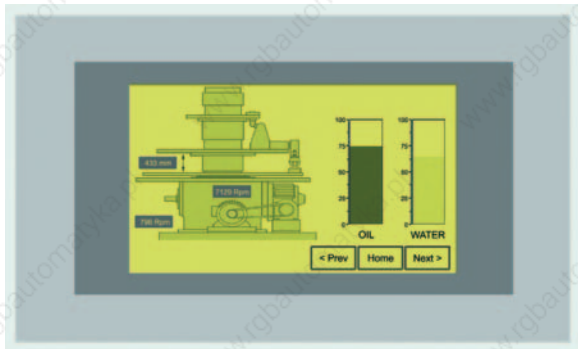

VT565W

Operator terminal with 5,7" graphic LCD display, 16 rows by 40 characters, 1/4 VGA (320 x 240), Touch Screen, 1 MB project, clock, 128 KB recipes.



VT585CE

Operator terminal with Windows® CE 3.0 operating system, 10,4" colour graphic TFT LCD display, VGA (640 x 480), 64 MB RAM memory, 32 MB flash memory, LPT Centronics, PS2 for mouse and keyboard, RS 232, USB, 2 PCMCIA slots (type I), Ethernet interface, 75 operative keys.



How to connect an Operator Interface to a Control Techniques Drive

Control Techniques drives support a wide range of fieldbus and protocols - We actively promote and support open standards for communications. Modbus RTU is commonly chosen for operator interfaces and is supported by all of our drives allowing most operator panels to be used, this means that if you have already developed a solution with another manufacturers operator panel it is extremely likely that we can interface to it without any major problems.

We have however chosen to work with Horner and ESA based on competence and product ranges, both also offer a significant advantage when used with a CNet network by supporting CNet Modbus function codes (See Below).

Connection to the serial Port

The operator interface is connected directly to the serial port, RS485 is a multi-drop protocol and so may be connected to several drive if required.

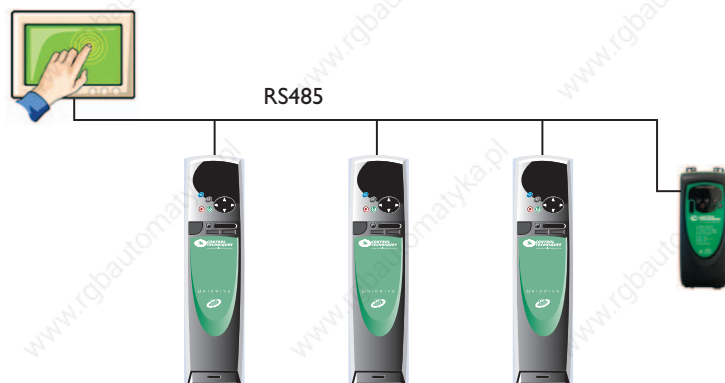

Commander SK showing connection to the serial port

Connecting via Ethernet

SM-Ethernet Option module allows the operator interface to be connected to the drive using Modbus TCP/IP.

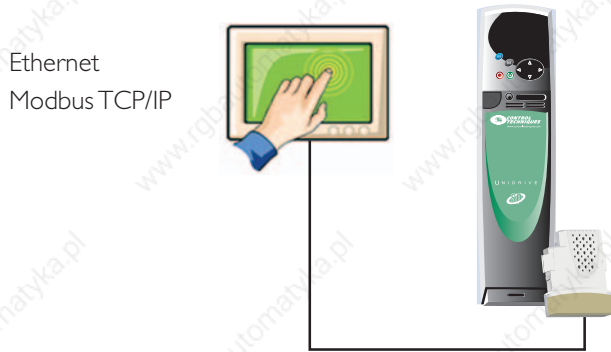

Connection using Fieldbus

Control Techniques drives support fieldbus communications through the use of Option modules, many operator interfaces also support fieldbus such as Profibus, DeviceNet etc. The drive is usually a slave on a fieldbus network and often so is the operator interface. This means that a master controller must be used and so it is important to establish how the operator interface will communicate, as it may be required to marshal the data through the master in the system.



Some Horner products are able to connect directly to Control Techniques drive-to-drive network CTNet by fitting an optional network adapter to the operator interface.

CTNet Modbus function codes

CTNet Modbus function codes allow the operator interface to access any Control Techniques drive connected to a CTNet network via a standard RS485 serial connection.

In the example below the operator panel is connected at a high-baud rate to the drives serial port and can obtain drive parameters from any of the drives on the three CTNet networks. This is possible using special Modbus function codes that pass the data through the drive to the CTNet network. This gives significant cost reductions and allows the operator panel to be a standard off-the-shelf model with no additional hardware.

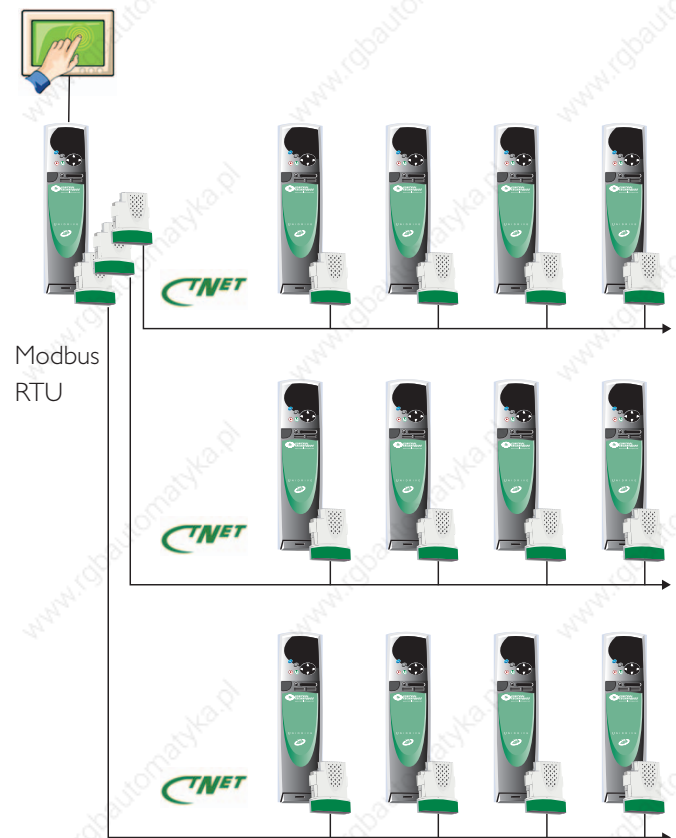

SM-Keypad



SM-Keypad, designed for use with Unidrive SD, has two rows of 7 segment LED displays. These are very easy to see at distance and in poor lighting conditions. The upper display shows the drive status or the current menu and parameter number. The lower display shows the parameter value or the specific trip type.

SM-Keypad Plus



SM-Keypad Plus, designed for use with Unidrive SD and Commander SK, has a multi-lingual backlit LCD display with three lines of text. Line 1 shows drive status or current menu and parameter number plus parameter value or the specific trip. Lines 2 and 3 show the parameter name or the help text.

There are five text databases as standard: French, Italian, German, Spanish and English plus a custom database for application specific text.

Help text is available at the press of a button.

The parameter set that may be browsed can be filtered, to tailor a drive to a specific application or industry.

With the standard communications cable and Windows text string tool from Control Techniques, you can customise the human-machine interface of SM-Keypad Plus to your own specific application, and make it your own.

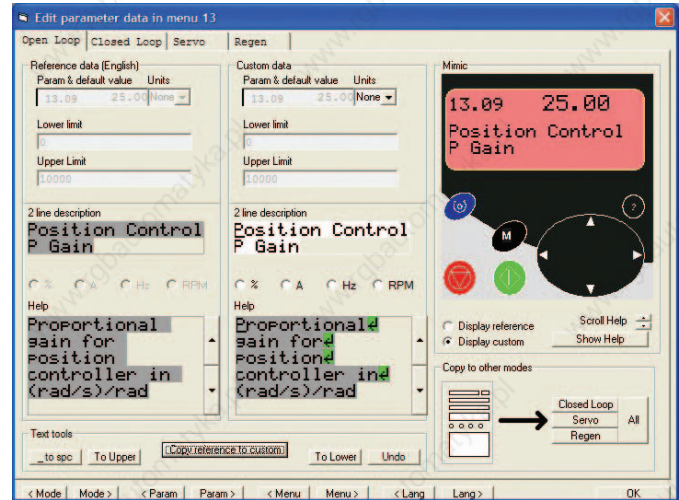

Parameter text may be customised using a Windows tool, for applications or further languages

Universal Keypad

The Universal Keypad makes programming Control Techniques' most popular drives fast and simple. This remote keypad has a 2-line, 16-character, green back-lit LCD display. A built-in database defines all drive parameters in real units. Start, Stop / Reset and Reverse keys make pushbutton control quick and easy while five navigation keys provide fast browsing and modification of parameters.

Customer-defined macro functions can be accessed through three programmable soft keys. The two line display can be programmed to display any drive parameter, apply a scale factor, offset and descriptive text. The 2 or 4-wire RS485 communications provides single or multi-drop connectivity with a combination of Control Techniques digital drives and their option modules.

Its IP65 rating provides rugged protection whether it is hand-held or panel mounted. To further simplify installation, it's designed to be powered from a Control Techniques drive^① rather than require an external power source.

① 24VDC, 200 mA when supplied from a drive. Separate power supply requires fast-acting 24VDC / 250 mA fuse.

- **Plain text parameter descriptions for ControlTechniques digital drives**
- **Hand-held or panel mounted**
- **IP65 Rating**
- **2 or 4-wire RS485 for single or multiple drive connection**
- **Password protection**
- **Programmable display**
- **Suitable for use with Commander SE, and Mentor II**

DIMENSIONS (mm)

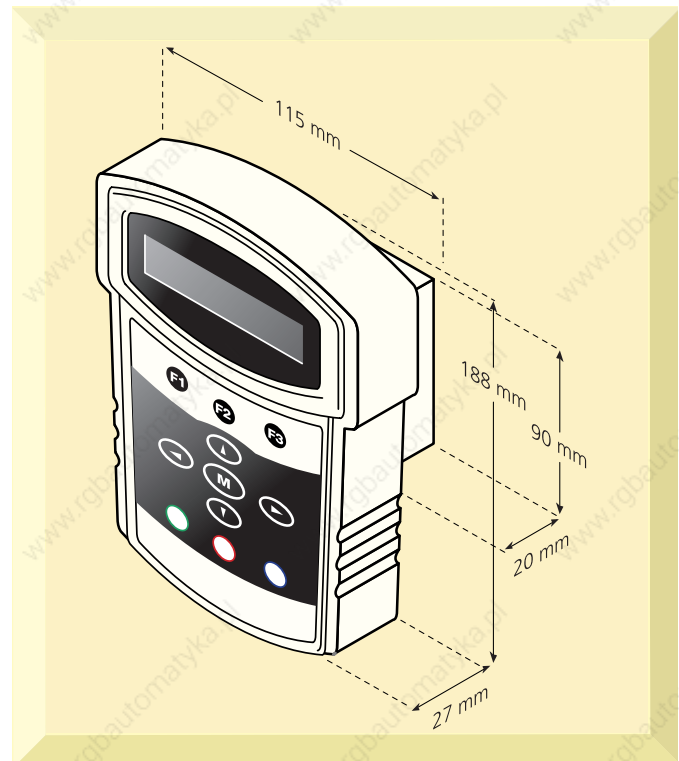

Power Accessories

Dynamic Braking Resistors

Dynamic braking resistors provide a means of rapidly stopping a rotating motor and load. The mechanical energy stored in the spinning mass is converted into electrical energy and quickly dissipated into the resistor. The ohmic value and power rating of the resistor is a function of the drive type.

DC drives provide an exponential stopping profile when a dynamic brake resistor is applied across the motor's armature circuit (when the motor acts as a DC generator). This type of braking can occur only when the drive is configured for coast stop and power has been removed from the motor (stop commanded).

AC drives provide a constant torque stopping profile when a dynamic brake resistor is applied across the DC bus circuit. Dynamic braking can be employed under a stop command or anytime a decrease in motor speed is commanded, provided the AC drive is "Active" and programmed for ramp stop (fast ramp mode). Since the "dynamic brake" is active anytime the system is powered up, the braking circuit must be protected with an overload device.

Control Techniques offers two types of dynamic braking kits for AC Drives.

The E-stop duty kits provide a means of quickly stopping a motor / load as well as providing the ability to dissipate energy created by either a change in motor speed or a line transient (commutation spike from a DC drive) which might otherwise cause nuisance over-voltage trips. The cyclic duty kits are intended for more severe applications that need the capability to dissipate regenerated energy on a more continuous or repetitive basis such as indexers, feeders and dynamometers.

To order: consult your local Drive Centre /Distributor for locally stocked solution.

E-Stop Duty

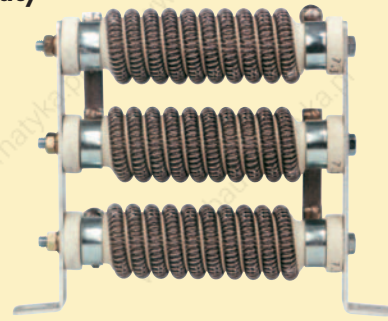

Overload Protection

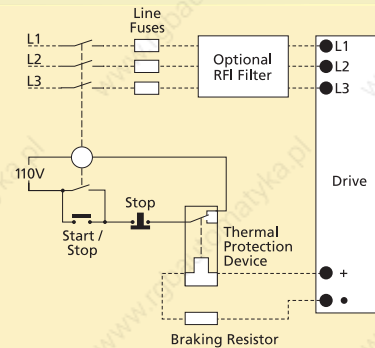

Cyclic Duty Resistor Assembly

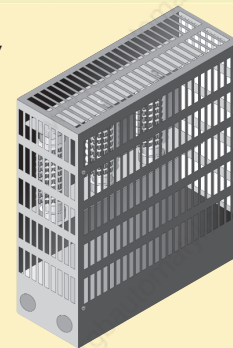

Duty Cycle

$$\text{Duty Cycle} = \frac{\text{On Time} (\leq \text{max "on" time})}{\text{On Time} + \text{Off Time}}$$

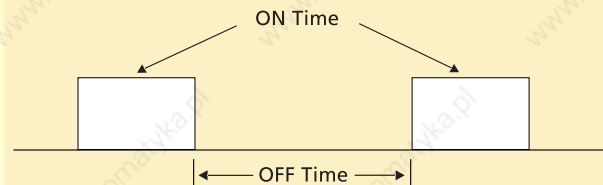

Line and Load Reactors

Line reactors (also called line chokes) are a common power accessory for electronic variable speed drives. These components add an extra margin of protection for AC and DC drives by reducing the local effects of power line transients resulting from Power Factor (PF) correction capacitor switching, lightning storms and general power grid switching. Line reactors are also used on the output of AC drives to reduce the effects of high motor wiring capacitance (nuisance overcurrent trips) and to "soften" the dv / dt (high rates of change of voltage) applied to the motor windings.

Reactors in AC drive applications:

- **Improve system power factor and help meet IEEE 519 criteria by reducing harmonic distortion of the input line current**
- **Improve input line current balance**
- **Reduce nuisance drive over-voltage trips caused by transient voltage spikes and power line notches**
- **Protect input rectifiers from in-rush current caused by sudden power line surges and sags**
- **Extend the life of the DC bus capacitor bank by reducing the internal heating caused by ripple current**
- **Protect motor windings from long lead effects when used on the drive output**

Line Reactors in DC drive applications:

- **Minimise crosstalk between multiple SCR drives by reducing line notching and subsequent dv / dt misfiring / bridge failures**
- **Eliminate SCR failures caused by high dv/dt levels associated with stiff or power factor corrected power lines**
- **Protect other line-powered sensitive electronic equipment by filtering electrical noise / interference caused by drives on the power line**

To order: consult your local Drive Centre /Distributor for locally stocked solution.

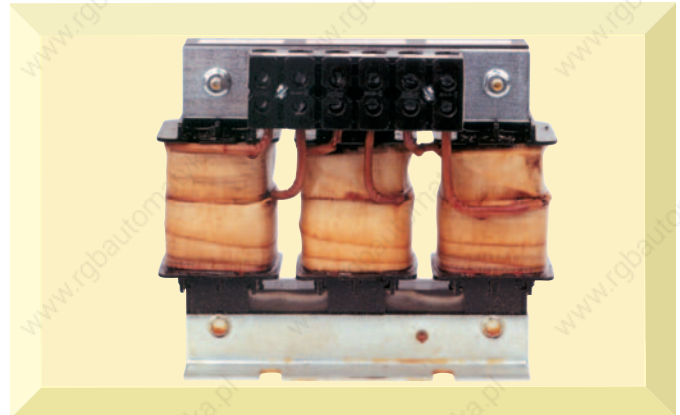

Isolation Transformer

Drive isolation transformers add an extra margin of protection for AC and DC drives by reducing the effects of power line transients resulting from local power factor correction capacitor switching, lightning storms and general power grid switching. They are sized to the drive KVA requirements and are designed to withstand the mechanical stresses of current reversals and short circuits associated with power semiconductor type AC and DC drives.

Isolation transformers:

- **Provide electrical isolation between the incoming line and the drive electronics**
- **Convert input line voltage to standard drive input voltages**
- **Minimise line disturbances caused by SCR power converters**
- **Reduce power line harmonics caused by drives**
- **Protect the motor controller by reducing available short circuit potential. This may be a UL requirement in installations with high levels of short circuit potential**



Electromagnetic Compatibility Filters

EMC filters are used to minimise high frequency power supply line disturbances caused by PWM AC drives that may interfere with proper operation of sensitive electronic equipment. These specific filters have been assessed for conformance with the EMC directive by testing with the appropriate Control Techniques drives.

EMC data sheets are available for digital drive products. These data sheets list the applicable harmonised standards and give recommended installation techniques and further information on EMC behaviour in typical situations.

The filters are built and tested to the safety standard EN-33200.



Commander SK EMC Filter Selection

Drive Order Code	EMC Filter Order Code	Phases	Voltage (A)	Mounting Style
Commander SK size A	4200-6122	1	200-240V	Footprint
Commander SK size B	4200-6212	1	200-240V	Footprint
Commander SK size C	4200-6310	1	200-240V	Footprint
Commander SK size B	4200-6213	1	380-480V	Footprint
Commander SK size C	4200-6311	1	380-480V	Footprint
Low Earth Leakage Applications				
Commander SK size C	4200-6123	1	200-240V	Footprint
Commander SK size C	4200-6214	1	200-240V	Footprint
Commander SK size C	4200-6312	1	200-240V	Footprint

Commander SE EMC Filter Selection

Drive Order Code	EMC Filter Order Code	Filter Type	Mounting Style	Current (A)	Dimensions (mm) L x W x H
230 VAC					
SE11200025 - 075	4200-6102	Standard	Footprint / Bookend	12	242 x 100 x 40
	4200-6101	Light Duty	Block	12	114 x 58 x 46
	4200-6103	Low leakage	Footprint / Bookend	12	242 x 100 x 40
SE2D200075 - 220 Single Phase	4200-6201	Standard	Footprint / Bookend	26	330 x 148 x 45
	4200-6204	Light Duty	Block	26	119 x 86 x 58
	4200-6205	Low leakage	Footprint / Bookend	26	330 x 148 x 45
SE2D200075 - 220 Three Phase	4200-6202	Standard	Footprint / Bookend	16	330 x 148 x 45
	4200-6304	Light Duty	Block	16	119 x 86 x 58
	4200-6207	Low leakage	Footprint / Bookend	16	330 x 148 x 45
SE23200400	4200-6203	Standard	Footprint / Bookend	26	330 x 148 x 45
	4200-6303	Light Duty	Block	26	133 x 118 x 70
	4200-6209	Low leakage	Footprint / Bookend	26	330 x 148 x 45
SE33200550 - 750	4200-6302	Standard	Footprint / Bookend	30	385 x 190 x 50
	4200-6303	Light Duty	Block	30	133 x 118 x 70
480 VAC					
SE23400075 - 400	4200-6202	Standard	Footprint / Bookend	16	330 x 148 x 45
	4200-6304	Light Duty	Block	16	119 x 86 x 58
	4200-6207	Low leakage	Footprint / Bookend	16	330 x 148 x 45
SE33400550 - 750	4200-6301	Standard	Footprint / Bookend	18	385 x 190 x 50
	4200-6304	Light Duty	Block	18	119 x 86 x 58
SE43401100 - 1500	4200-6401	Standard	Footprint / Bookend	33	467 x 246 x 55
	4200-6402	Light Duty	Block	33	143 x 128 x 80
SE43401850	4200-6403	Standard	Footprint / Bookend	37	467 x 246 x 60
	4200-6404	Light Duty	Block	37	143 x 128 x 80
SE53402200	4200-6116	Standard	Bookend	50	337 x 100 x 90
SE53403000	4200-6117	Standard	Bookend	63	377 x 103 x 150
SE53403700	4200-6106	Standard	Bookend	100	380 x 107 x 150

Mounting Style

- **Bookend:** filter mounts next to the drive with the smallest dimension being the width of the filter
- **Footprint:** filter mounts between the drive heatsink and the panel or enclosure
- **Block:** filter mounts on the panel near the drive

Filter Type

- **Light Duty:** designed for use in industrial applications* with motor lead lengths <20m
- **Low Leakage:** designed for use in industrial or residential applications* with motor cable lengths <15m
- **Standard:** designed for use in industrial or residential applications* with motor cable lengths <75m

Unidrive EMC Filter Selection

* As defined by CE standards for EMC compliance

Note: A zero-space EMC filter adequate for most applications is standard on the Unidrive .

Drive Order Code	EMC Filter Order Code	Mounting Style	Current (A)	Dimensions (mm) H x W x D
200V AC				
SP1201-1202	4200-6118	Footprint/Bookend	10	440 x 100 x 45
SP1203-1204	4200-6119	Footprint/Bookend	16	440 x 100 x 45
SP2201-2203	4200-6210	Footprint/Bookend	32	429 x 155 x 55
SP3201-3202	4200-6307	Footprint/Bookend	75	414 x 250 x 60
SP4201-4203	4200-6406	Block	101	300 x 225 x 100
400V AC				
SP1401-1404	4200-6118	Footprint/Bookend	10	440 x 100 x 45
SP1405-1406	4200-6119	Footprint/Bookend	16	440 x 100 x 45
SP2401-2403	4200-6210	Footprint/Bookend	32	429 x 155 x 55
SP3401-3403	4200-6305	Footprint/Bookend	62	414 x 250 x 60
SP4401-4403	4200-6406	Block	101	300 x 225 x 100
SP5401-5402	4200-6503	Block	164	300 x 250 x 120
SP6401-6402	4200-6603	Block	260	*
575V AC				
SP3501-3507	4200-6309	Footprint/Bookend	30	414 x 250 x 60
690V AC				
SP4601-4606	4200-6408	Block	*	*
SP5601-5602	4200-6504	Block	*	*
SP6601-6602	4200-6604	Block	*	*

* Consult Drive Centre

Mentor EMC Filter Selection

Drive Order Code	Line reactors La, Lb, Lc (μH)	EMC Filter Order Code	Mounting Style	Current (A)	Dimensions (mm) H x W x D
M25, M25R	200	4200-6116	Bookend	50	337 x 100 x 90
M45, M45R	200	4200-6116	Bookend	50	337 x 100 x 90
M75, M75R	100	4200-6117	Bookend	63	377 x 103 x 150
M105, M105R	100	4200-6106	Bookend	100	380 x 107 x 150
M155, M155R	75	4200-6107	Bookend	150	414 x 135 x 175
M210, M210R	75	4200-6111	Bookend	180	502 x 157 x 170
M350, M350R	35	4200-6115	Bookend	300	655 x 156 x 230

For higher current ratings consult Drive Centre/Distributor

For further information, documentation and local support go to www.controltechniques.com

CT-START-Soft Starter

OVERVIEW

CT-START is a multi-function electronic motor starter incorporating a microprocessor, control circuitry and a thyristor power stage. It is designed for use with all 3-phase squirrel cage induction motors.

Unlike the traditional systems (Direct-on-Line (D.O.L.), star-delta, resistors, etc), CT-Start limits and controls the starting current and ensures very smooth and steady acceleration.

CT-START includes protection and control system functions which means that installations are kept simple and component costs are reduced.



FEATURE PERFORMANCE

Current Limitation

All traditional motor starter systems cause a current peak during the starting phase, which can vary between 6 and 9 times the motor nominal rated current.

CT-START, by simple adjustments, can limit the current precisely during the start-up phase, whilst monitoring all the thermal characteristics of the motor:

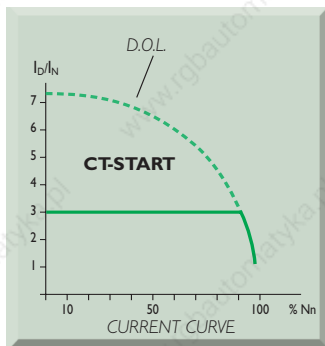
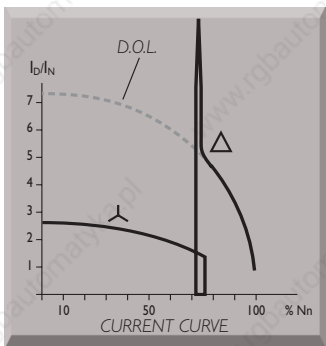

Smooth Starting

Starting a motor generates current surges, vibrations, voltage drops, imbalances, transmission slackening, pressure surges and mechanical stress.

CT-START's electronic design means that it can be used for smooth starting and precise adjustment of the starting torque.

It ensures smooth acceleration, thus limiting the forces to which the machine is subjected.

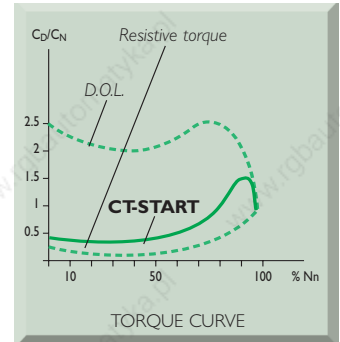
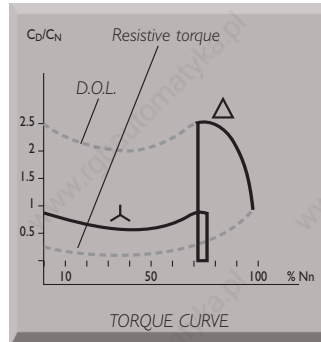

Integral Protection

Starting, protecting and automating motor control systems traditionally requires the installation of a large number of control gear components, which means that the control panels are both complex and physically large.

CT-START offers several supplementary functions which can limit the requirement for additional components, thus resulting in a reduction in the cost of materials, labour and operation. An increase in motor control reliability is typically obtained by simplifying the installation.

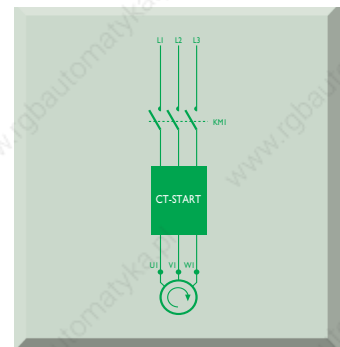
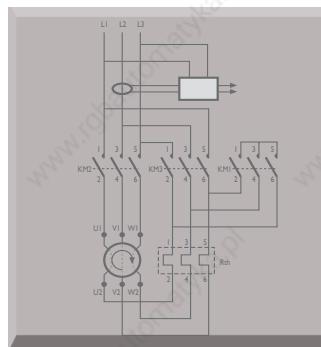

RATINGS

200 to 500VAC		50/60Hz 3 Phase	
Model	Rated Motor Current	Maximum Starts per hour at 3 x In	Maximum start time at 3 x In
STVI312 14 06	6	15	30s
STVI312 14 10	10	15	30s
STVI312 14 16	16	10	30s
STVI312 14 22	22	10	30s
STVI312 14 30	30	10	30s
STVI312 14 44	44	10	30s

500 to 690VAC		50/60Hz 3 Phase	
Model	Rated Motor Current	Maximum Starts per hour at 3 x In	Maximum start time at 3 x In
STVI312 16 06	6	15	30s
STVI312 16 10	10	15	30s
STVI312 16 16	16	10	30s
STVI312 16 22	22	10	30s
STVI312 16 30	30	10	30s
STVI312 16 44	44	10	30s

200 to 500VAC		50/60Hz 3 Phase	
Model	Rated Motor Current (A)	Maximum Starts per hour at 3 x In	Maximum start time at 3 x In
STV2313 14 37	37	10	30s
STV2313 14 60	60	10	30s
STV2313 14 86	86	10	30s
STV2313 14 145	145	10	30s
STV2313 14 211	211	10	20s
STV2313 14 250	250	5	20s
STV2313 14 365	365	5	20s
STV2313 14 530	530	5	20s
STV2313 14 700	700	5	20s
STV2313 14 900	900	5	20s

500 to 690VAC		50/60Hz 3 Phase	
Model	Rated Motor Current (A)	Maximum Starts per hour at 3 x In	Maximum start time at 3 x In
STV2313 16 37	37	10	30s
STV2313 16 60	60	10	30s
STV2313 16 86	86	10	30s
STV2313 16 145	145	10	30s
STV2313 16 211	211	10	20s
STV2313 16 250	250	5	20s
STV2313 16 365	365	5	20s
STV2313 16 530	530	5	20s
STV2313 16 700	700	5	20s
STV2313 16 900	900	5	20s



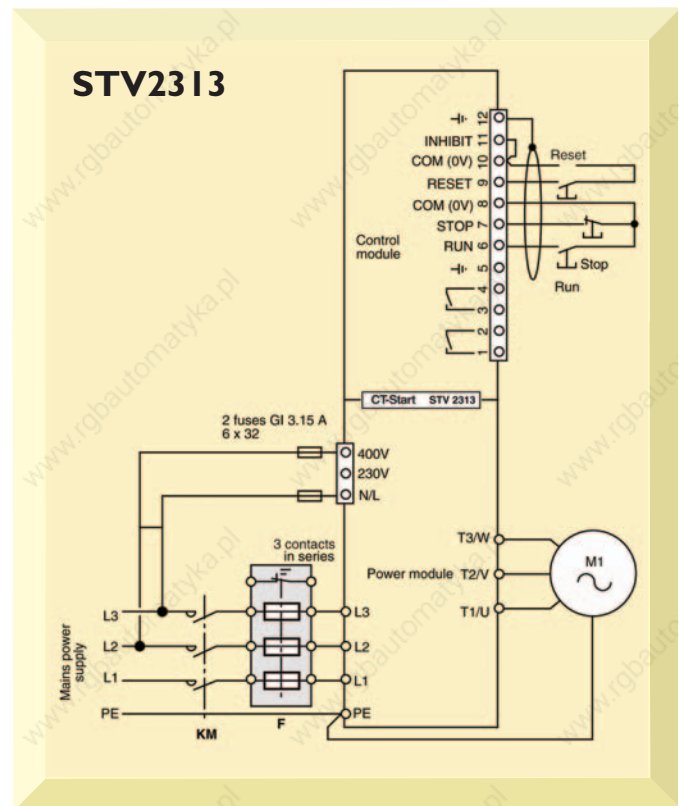
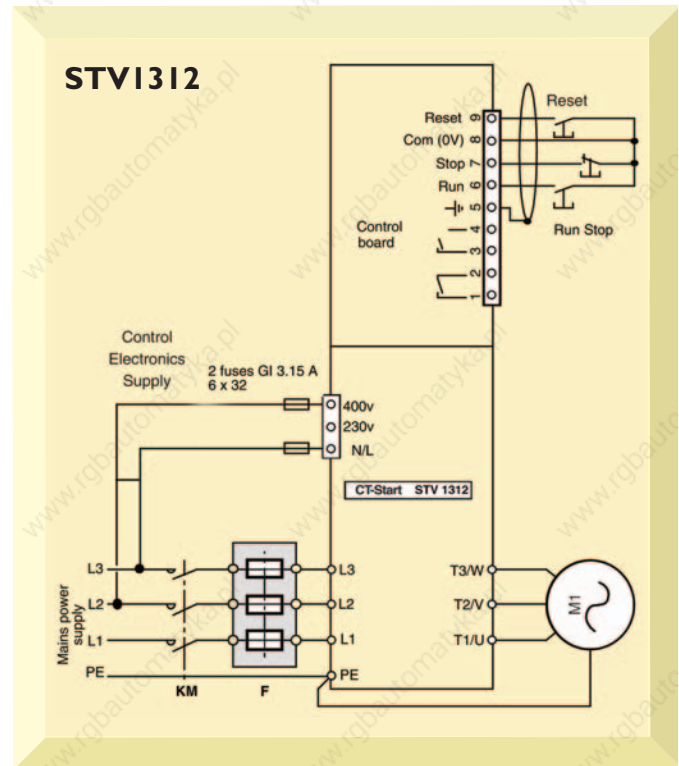

In= Motor rated current

TERMINAL DIAGRAMS

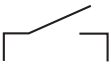

TERMINAL DESCRIPTION

CT-START

Reference	No. of terminal	Designation	Function/Characteristic
Outputs			
	1	K1 relay *	Normally open relay Max. voltage 250V AC
	2		
	3	K2 programmable output relay	Switching power : 3A non inductive load
	4		
Inputs			
	5	Ground terminal	Connection of shielding
Run	6	Run - stop control inputs	For permanent connection: 6-8 linked 7-8 run command: C = Run O = Stop For momentary action: 6-8 Run command momentary close 7-8 Stop command momentary open
Stop	7		
Com	8		
Reset	9	Trip reset input	Momentary close terminals 9 and common.
Com	10	Common terminal	Electronic reference voltage
Inhibit	11	Emergency stop input	Emergency stop on opening of the link between terminals 11 and Common. Immediate and direct inhibiting of thyristors
	12	Ground terminal	Connection of shielding

* This relay becomes programmable using the optional remote keypad.

DIMENSIONS (mm)

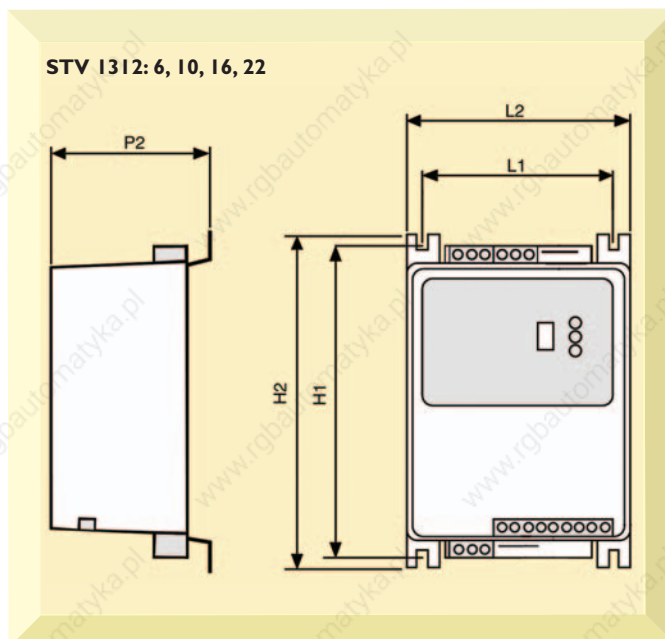

DIMENSIONS (mm)

Rating	STV1312	6	10	16	22	30	44
Mounting	H1	253	253	253	253	336	336
	L1	130	130	130	130	169	169
Screw Ø	D1	6.5	6.5	6.5	6.5	6.5	6.5
Overall	H2	273	273	273	273	356	356
	P2	116	116	153	153	138	138
	L2	155	155	155	155	209	209
Weight	(kg)	2.2	2.2	4.3	4.3	4.8	4.8

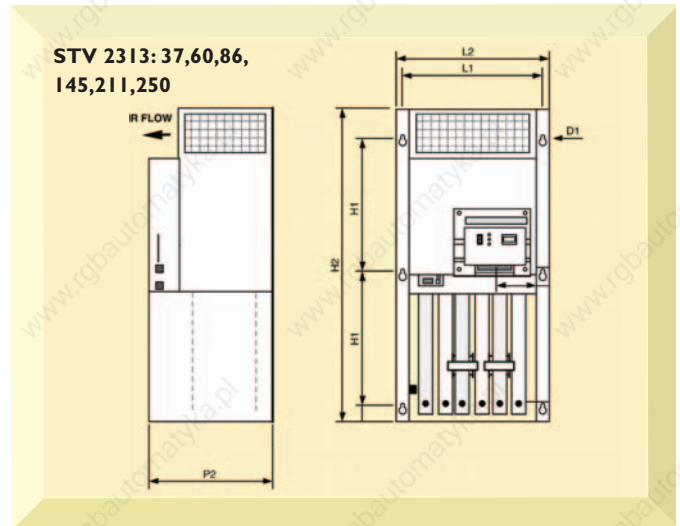
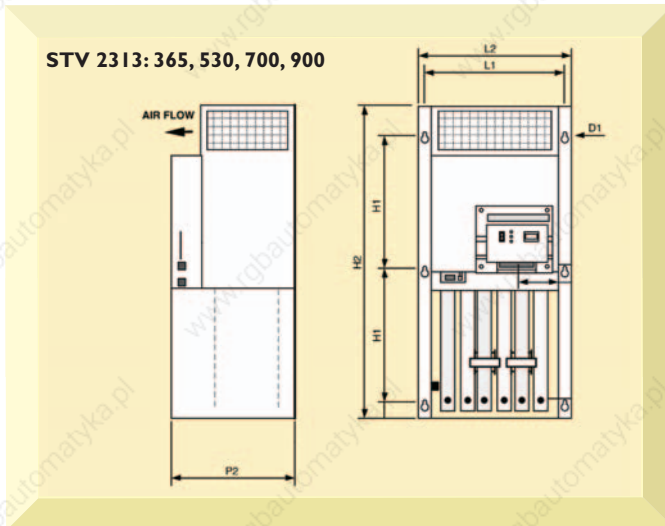

DIMENSIONS (mm)

Rating	STV 2313	37	60	86	145	211	250	365	530	700	900
Mounting	H1	336	350	350	385	385	385	300	300	300	300
	L1	169	168	168	240	240	240	410	410	410	410
Screw Ø	D1	6	6	6	6	6	6	12	12	12	12
Overall	H2	355	370	370	405	405	405	803	803	803	803
	P2	235	235	235	265	265	265	365	365	365	365
	L2	220	220	220	370	370	370	445	445	445	445
Weight	(kg)	9	9	9	25	25	25	55	55	65	5

OPTIONS CT52313

ES START – I/O MODULE

- 2 logic inputs
 - management of external faults,
 - or multi-parameter entry: starting several motors, 2-speed motors, no-load or on-load starting
- 2 logic outputs - can provide 4 alarm relays
- 1 analogue input
- 1 PTC input (6 probes)
- 2 analogue outputs - can provide feedback relating to the current or the power drawn by the motor



CDC START – REMOTE KEYPAD

The **CDC START** terminal has 8 keys, 1 LED and 1 32-character LCD, and is designed for starters in the **CTS 2313** range.

When used with the base model, it:

- is used for programming, diagnostics and displaying the parameters,
- provides clear displays concerning the operation of the motor,
- accesses additional functions:
 - saving a set of parameters
 - limiting the number of starts
 - locking the settings using a personal code
 - additional, more precise settings
 - entering option parameters, etc



RV START – SPEED FEEDBACK CONTROL MODULE

The **RV-START** module, when used with the **CT-START CTS**, controls the speed feedback in order to ensure smooth repetitive starts, whatever the load of the machine being driven.

Applications: installations where the starting load varies considerably (conveyors, bucket elevators, mixers, ball mills, etc.)

The **RV-START** module also has a logic input which allows for the double entry of **CT-START** parameters when it is being used with a 2-speed motor:

- 3 types of speed feedback:
 - D.c. or a.c. tacho
 - 3-wire proximity sensor
 - 4 - 20 mA signal



FR START – D.C. INJECTION MODULE

- Braking before starting
- Braking on deceleration
- Keeping the motor free from condensation
- Drying the motor



OTHER OPTIONS

- Quick-blow fuses, optional on ratings ≤ 250 A, and standard on ratings ≥ 365 A
- IP 20 kit on ratings ≤ 250 A
- IP 53 version
- Connection kit
- Starter enclosure
- Autotransformer

Unimotors

OVERVIEW

The Unimotor range has been developed following extensive research and testing of thermal dynamic theories and practices.

This range is available in five frame sizes 75; 95; 115; 142 and 190mm, in a unique and instantly recognisable finned design that offers extra strength, rigidity and thermal performance. These are important features for high performance servo systems.

Designed to operate from switched-mode three-phase AC drive outputs with DC link volts up to 750V DC, this range employs a registered UL approved insulation system.

There are three basic motor types, each for different drives.

UM and (SLM) motors are for 400/440V nominal AC drive supply voltage, for Unidrive (SD), M'Ax and MultiAx.

EZ motors have identical mechanical construction and feedback options, but support a different winding to suit 220V nominal AC drives such as Unidrive (SD) and Epsilon drives.

UM, EZ AND (SLM) MOTORS

UM, EZ Motor

The UM motor has been primarily designed to operate with the Unidrive (SD), but can be used with any suitable drive.

Feedback options include resolver; or incremental, sincos single-turn, SinCos multi-turn optical encoders.

(SLM) Motor

The SLM version is a UM motor fitted with special (SLM) technology electronic feedback that operates with Control Techniques' M'Ax and MultiAx drives. This motor-drive combination offers extremely high resolution, for superb system speed control. High resolution is essential for many system applications where speed and position errors must be miniscule.

The feedback comprises of a special SinCos encoder and (SLM) electronics, both contained within the standard UM outline.

The encoder has a memory programmed with all the essential motor characteristics necessary to automatically set all M'Ax parameters, giving an instant 'Plug and Play' capability.

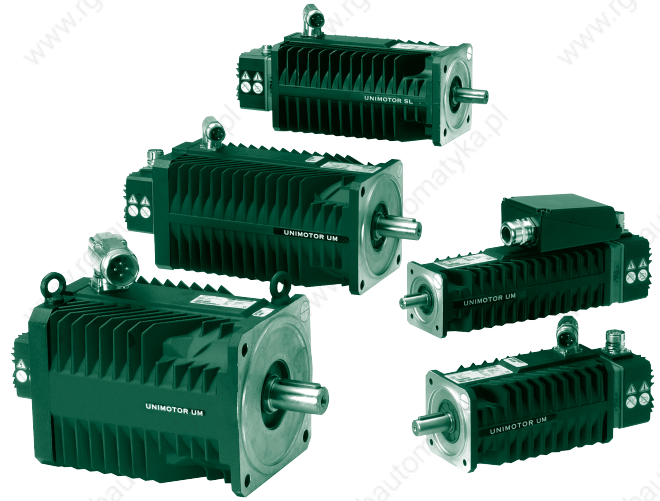

Other options

Gearboxes – motor torque can be extended by a good selection of factory-fitted gearboxes, available to order in a wide variety of options.

Forced air-cooling – customer-fitted fan blown boxes specially designed to fit the range of motors, helps to maintain the motor housing temperature. (Not suitable for (SLM) Motors).

Custom specials – a range of special adaptations e.g. shaft or feedback type are already designed and may be available where quantities justify.

Cable assemblies – ready made power and signal cables in lengths of 2-100 metres to connect motors to the appropriate drive.

ORDERING INFORMATION

Use the information given in the illustration below to create an order code for a Unimotor. The top line is an example of an order reference. Control Techniques recommends that you order the required mating connectors at the time of placing your motor order. For further details turn to cables. See also the grid overleaf, which gives standard and optional features available for each motor.

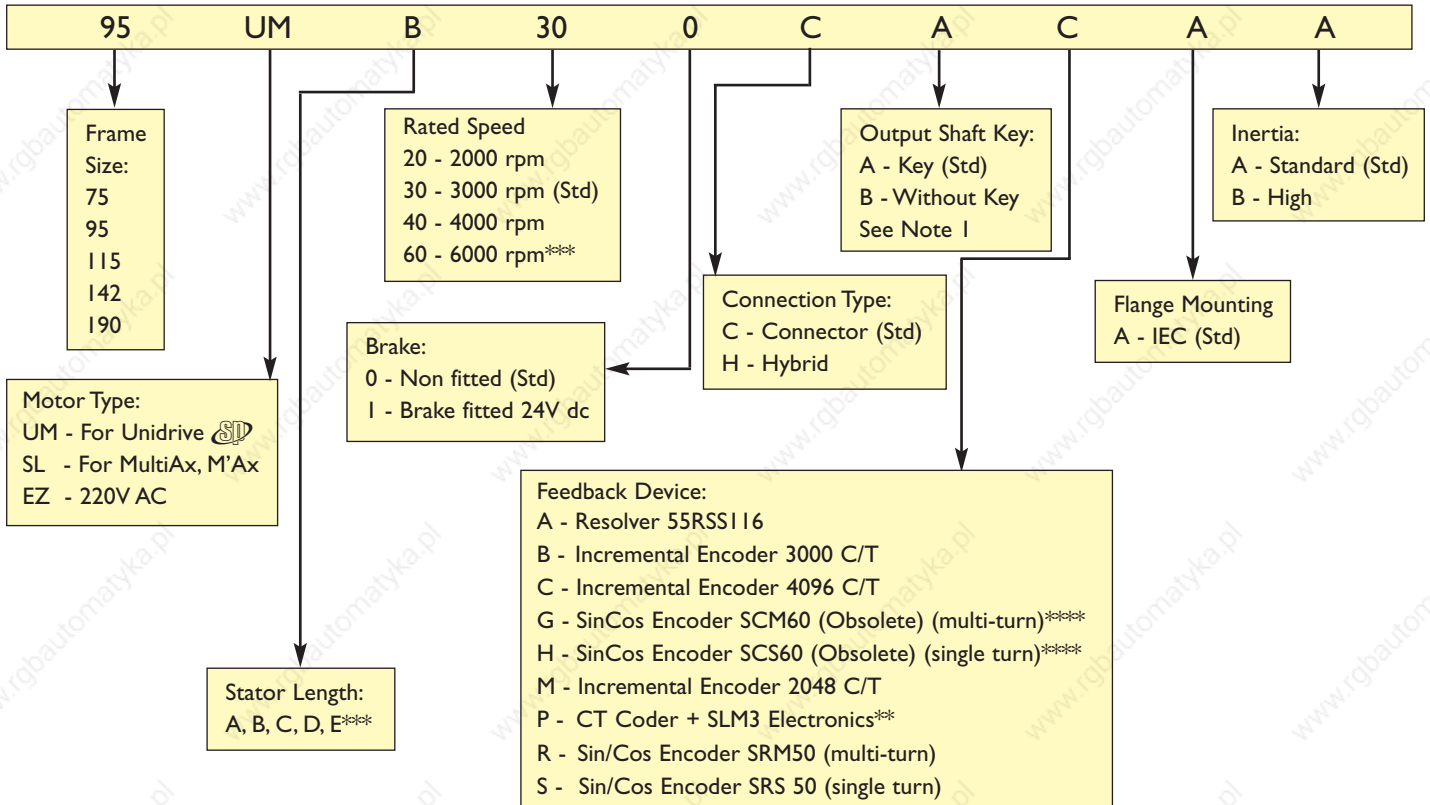

Note1: Applies to output shaft of motor or when gearbox fitted, output shaft of gearbox.



** Available for SLM motors only (D=SLM1 E= SLM2)

*** Not available for some motors

**** Replaced by R or S types

FEATURES – STANDARD & OPTIONAL

This chart shows the standard and optional features available with each motor:

Description	Order Ref.	Refers to	Unimotor Frame Size				
			75	95	115	142	190
Motor Type	UM	380-480 VAC Unidrive  , Epilson	●	●	●	●	●
	EZ	200-240 VAC Unidrive  , Epilson	■	■	■	■	■
	SL	380-480 VAC M'Ax & MultiAx	●	●	●	●	●
Stator Length	A		■	■	■	■	■
	B		■	■	■	■	■
	C		■	■	■	■	■
	D		■	■	■	■	■
	E		N/A	■	■	■	N/A
Rated Speed	10	1000 rpm	▲	▲	▲	▲	▲
	20	2000 rpm	■	■	■	■	■
	30	3000 rpm	●	●	●	●	●
	40	4000 rpm	■	■	■	■	▲
	60	6000 rpm	■	■	▲	▲	N/A
Brake	0	Non fitted	●	●	●	●	●
	I	Fitted 24V DC	■	■	■	■	■
Connection Type	C	Connector, rotatable	●	●	●	●	●
	H	Hybrid (Power terminal box)	▲	▲	▲	▲	▲
Output Shaft Key	A	With key	●	●	●	●	●
	B	Without key	■	■	■	■	■
	X	Special shaft or mechanical detail	▲	▲	▲	▲	▲
Feedback Device	C/M	Incremental encoder	●	●	●	●	●
	P	CT Coder (SLM only)	■	■	■	■	■
	R	SIN/COS encoder SRM50 (Multi)	■	■	■	■	■
	S	SIN/COS encoder SRS50 (Single)	■	■	■	■	■
	A	Resolver 55RSS 116	■	■	■	■	■
Flange Mounting	A	IEC Flange	●	●	●	●	●
Inertia	A	Standard	●	●	●	●	●
	B	High	■	■	■	■	■
CTD/IS/2000/01  E215243		UL Insulation system	●	●	●	●	●
		UL recognised motor	■	■	■	■	■

Note:  E215243 UL recognised motors to be requested at time of order.

Use the codes in the Order Ref. column to build your order code. Choose one reference from each of the description categories.

- - Standard Feature
- - Standard Option
- ▲ - Limited Availability Option
- N/A - Not Available

SPECIFICATION

Standard motors have UL and CAN/CSA recognised Insulation System to class. The CTD/IS/2000/01 insulation system number on the motor number plate, together with the symbol, denotes this. Earlier motors may display this information on a separate label on the rear cover.

If the UL symbol has "E215243" underneath, then this indicates full motor recognition.

Machinery Directive 89/392/EEC amended to 98/37/EC Low Voltage Directive 73/23/EEC

EN 60034 General requirements for rotating electrical machinery

EN 60034-1 Duty: S1 Continuous
Storage: -15° to +40°C Operating: Min ambient 40°C
Less than 1000M altitude
Relative humidity: 90% Non condensing
Thermal classification: H Delta 100/125°C

EN 60034-5 Degree of ingress protection: IP65S (mating connector & cable fitted)

EN 60034-6 Method of cooling: free circulation, free convection

EN 60034-7 Flange mounted: horizontally or vertically

EN 60034-8 Terminal markings: U V W

EN 60034-11 Thermal protection: PTC thermistor, I 65°C TPI I I (Not SL variants)

EN 60034-18 Insulation system: Class H 600V, UL number E214439

EN 60072 Dimensions and output for rotating electrical machines

EN 60072-1 Type N (Customer variants)

ISO 1940-1 Balancing: to G6.3 (ISO 8821 half key convention)

Equipment is not deemed suitable for use in an explosive atmosphere.

This product has been designed to be operated with Control Techniques drives and must not be put into service unless the machinery into which it is to be incorporated has been declared in conformity with the provisions of the machinery directive.

NAMEPLATE

Values shown for K_E , K_T , I_o , stall/rated torque ($M_{0/N}$) and power (P_N) are for motor at full maximum rating in a 40°C ambient.

$K_{E(NOM)}$ is the motor's back e.m.f. at 20°C.

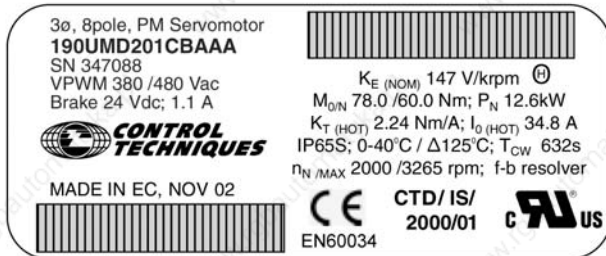

3ø, 8pole, PM Servomotor

Indicates number of poles. This motor has 8 poles or 4 pole pairs. Electrical frequency = (rpm/60) x (number of pole pairs)

190UMD201CBAAA

Motor type number – ref. Ordering information

VPWM 380 / 480 VAC For use with a VPWM (Voltage Pulse Width Modulation) Drive with supply voltage as indicated.

Brake 24 VDC; 1.1 A Brake supply requirements

$K_E(NOM)$ 147V/krpm K_E ac Volts per 1000rpm with motor at 20°C

$M_{0/N}$ 78.0 / 60.0 Nm M_o (Stall torque) = 78.0Nm; M_N (rated torque @ nominal speed rpm) = 60.0 Nm

P_N 12.6kW P_N (Power @ nominal speed) = 12.6 kW

$K_T(HOT)$ 2.24 Nm/A; $I_o(HOT)$ 34.8 A K_T (Torque Constant) at maximum operating temperature = 2.24 Nm/A
 $I_o(HOT)$ (Stall Current at maximum operating temperature) = 34.8 A

IP65S Ingress Protection = IP65S (excludes front shaft seal)

Insulation Class[®] Windings are built to Class H standard (180°C) Motor will have further ambient and Δt restrictions.

0-40°C / Δt 125°C Ambient temperature range / (delta) winding temperature increase above ambient (at full rating)

T_{CW} 632s Thermal Time-constant of copper winding with respect to iron laminations.

n_N/MAX 2000 / 3265 rpm n_N (nominal speed) = 2000 rpm / n_{MAX} (maximum speed) = 3265 rpm (at maximum drive supply voltage and no load or low torque)

Note: maximum speed given for motor includes limit of feedback device, but excludes drive limits.

f-b resolver Feedback Device is a resolver:

Feedback Type	Name
Resolver	"resolver"
Incremental 4096	"4096ppr"
Incremental 1024	"1024ppr"
Incremental 2048	"2048ppr"
CT Coder & SLM3	"SLM3"
SinCos SRM50 1024	"SRM50"
SinCos SRS50 1024	"SRS50"



EN60034

CE (Conformité Européenne) mark and reference number.
Note: A "Declaration of Incorporation" is contained within the Unimotor Installation Guide that accompanies each motor.

Unimotor UM and (SLM) servo motor technical specifications

For 3 Phase VPWM Drives 380-480 Vrms

Unimotors with Encoder Feedback
 $\Delta t = 100^{\circ}\text{C}$, 40°C ambient

Stall torque; stall current and power relate to maximum continuous operation in a 40°C ambient
 All data subject to +/-10% tolerance

Motor Frame Size (mm)		75				95					115					142					190			
All Speeds	Frame Length	A	B	C	D	A	B	C	D	E	A	B	C	D	E	A	B	C	D	E	A	B	C	D
Continuous Stall Torque (Nm)		1.2	2.2	3.1	3.9	2.3	4.3	5.9	7.5	9.0	3.5	6.6	9.4	12.4	15.3	6.3	10.8	15.3	19.8	23.4	21.8	41.1	58.7	73.2
Peak Torque (Nm)		3.6	6.6	9.3	11.7	6.9	12.9	17.7	22.5	27.0	10.5	19.8	28.2	37.2	45.9	18.9	32.4	45.9	59.4	70.2	65.4	123	176	219
High Inertia (kgcm^2)		1.2	1.6	2.1	2.5	3.5	4.5	5.6	6.7	7.8	9.7	12.0	14.3	16.6	18.8	21.6	28.0	34.3	40.7	47.0	93.5	141	188	235
Standard Inertia (kgcm^2)		0.6	1.0	1.5	1.9	1.4	2.5	3.6	4.7	5.8	3.2	5.5	7.8	10.0	12.3	7.8	14.1	20.5	26.8	33.1	50.0	97.0	144	191
Winding Thermal Time Const.(sec)		81	74	94	100	172	168	183	221	228	175	185	198	217	241	213	217	275	301	365	240	242	319	632
Maximum Cogging (Nm)		0.02	0.03	0.04	0.05	0.03	0.06	0.08	0.10	0.13	0.06	0.10	0.14	0.18	0.21	0.09	0.16	0.23	0.30	0.35	0.30	0.30	0.54	0.72
Rated Speed 2000 (rpm)		Kt (Nm/A) 2.40 Ke (V/krpm) 147																						
Rated Torque (Nm)		1.1	2.1	3.0	3.8	2.2	4.0	5.5	6.9	8.2	3.2	6.1	8.7	10.8	14.0	5.9	10.3	14.6	18.4	21.3	20.0	36.9	50.4	54.7
Continuous Stall Current (A)		0.5	1.0	1.3	1.7	1.0	1.8	2.5	3.2	3.8	1.5	2.8	4.0	5.2	6.4	2.7	4.5	6.4	8.3	9.5	9.1	17.2	24.5	30.5
Rated Power (kW)		0.23	0.44	0.63	0.80	0.46	0.84	1.15	1.45	1.72	0.67	1.28	1.82	2.26	2.93	1.24	2.16	3.06	3.85	4.46	4.19	7.73	10.6	11.5
R (ph-ph) (Ohms)		144	48.2	25.0	15.7	59.0	17.0	9.90	6.00	4.30	27.8	8.55	4.55	2.96	2.17	12.5	3.60	2.10	1.35	0.98	1.80	0.56	0.33	0.23
L (ph-ph) (mH)		214	99.2	59.2	44.7	131	54.5	36.5	25.6	18.9	94.6	40.5	25.7	18.6	14.7	58.0	29.8	18.7	13.6	10.7	28.1	13.0	8.90	6.30
Rated Speed 3000 (rpm)		Kt (Nm/A) 1.6 Ke (V/krpm) 98.0																						
Rated Torque (Nm)		1.1	2.0	2.8	3.5	2.0	3.9	5.4	6.8	8.1	3.0	5.5	8.1	10.4	12.6	5.4	9.0	12.2	15.8	18.0	19.2	33.0	35.0	36.8
Continuous Stall Current (A)		0.8	1.4	2.0	2.5	1.5	2.7	3.7	4.7	5.7	2.2	4.2	5.9	7.8	9.6	4.0	6.8	9.6	12.4	14.7	13.7	25.7	36.7	45.8
Rated Power (kW)		0.35	0.63	0.88	1.10	0.63	1.23	1.70	2.14	2.54	0.94	1.73	2.54	3.27	3.96	1.70	2.83	3.83	4.96	5.65	6.03	10.4	11.0	11.6
R (ph-ph) (Ohms)		60.8	20.1	10.5	7.5	24.5	6.80	4.00	2.50	2.00	12.6	3.86	2.02	1.40	1.10	5.63	1.72	0.94	0.61	0.44	0.79	0.30	0.14	0.09
L (ph-ph) (mH)		98.4	41.8	27.6	19.7	57.9	24.3	15.5	10.9	8.50	43.1	18.6	11.4	8.60	7.40	31.0	13.3	8.30	6.10	4.80	13.2	6.11	3.60	2.46
Rated Speed 4000 (rpm)		Kt (Nm/A) 1.20 Ke (V/krpm) 73.5																						
Rated Torque (Nm)		1.0	1.7	2.3	2.9	1.8	3.0	4.0	4.9	5.7	2.5	4.7	6.3	7.5	8.7	3.6	7.0	8.9	10.7	12.2	▲	▲	▲	N/A
Continuous Stall Current (A)		1.0	1.9	2.8	3.3	2.0	3.5	5.0	6.3	7.5	3.0	5.5	7.9	10.4	12.8	5.3	9.0	12.8	16.5	19.5				
Rated Power (kW)		0.42	0.71	0.96	1.21	0.75	1.26	1.68	2.05	2.39	1.05	1.97	2.64	3.14	3.64	1.51	2.93	3.73	4.48	5.11				
R (ph-ph) (Ohms)		36.8	10.5	6.30	4.20	12.7	4.08	2.10	1.50	1.03	6.91	2.14	1.16	0.73	0.57	3.12	1.00	0.53	0.35	0.24				
L (ph-ph) (mH)		54.9	24.8	14.9	10.8	31.5	13.6	8.50	6.30	4.80	23.5	10.2	6.60	4.70	3.90	17.6	7.50	4.70	3.60	2.70				
Rated Speed 6000 (rpm)		Kt (Nm/A) 0.80 Ke (V/krpm) 49.0																						
Rated Torque (Nm)		0.9	1.6	2.1	2.6	1.3	2.1	2.8	3.3	3.7	2.2	4.0	5.1	▲	N/A	2.9	4.5	▲	▲	N/A				
Continuous Stall Current (A)		1.5	2.8	3.9	4.9	2.9	5.4	7.4	9.4	11.3	4.4	8.3	11.8			7.9	13.5							
Rated Power (kW)		0.57	1.01	1.32	1.63	0.82	1.32	1.76	2.07	2.32	1.38	2.51	3.20			1.82	2.83							
R (ph-ph) (Ohms)		15.0	5.00	2.66	1.90	5.45	1.82	1.05	0.62	0.48	3.1	0.97	0.50			1.42	0.46							
L (ph-ph) (mH)		24.0	10.6	6.80	4.80	14.1	6.00	3.80	2.70	2.10	15.54	4.81	2.94			7.72	3.44							

N/A Not Available

▲ Consult factory

The information contained in this specification is for guidance only and does not form part of any contract
 Control Techniques have an ongoing process of development and reserve the right to change the specification without notice.

Unimotor EZ servo motor technical specifications

For 3 Phase VPWM Drives 200 - 240Vrms

Unimotors with Encoder Feedback Δt = 100°C, 40°C ambient

Stall torque; rated torque and power
relate to maximum continuous operation in a 40°C ambient

All data subject to +/-10% tolerance

Motor Frame Size (mm)		75				95					115					142					190			
All Speeds	Frame Length	A	B	C	D	A	B	C	D	E	A	B	C	D	E	A	B	C	D	E	A	B	C	D
Continuous Stall Torque (Nm)		1.2	2.2	3.1	3.9	2.3	4.3	5.9	7.5	9.0	3.5	6.6	9.4	12.4	15.3	6.3	10.8	15.3	19.8	23.4	21.8	41.1	58.7	73.2
Peak Torque (Nm)		3.6	6.6	9.3	11.7	6.9	12.9	17.7	22.5	27.0	10.5	19.8	28.2	37.2	45.9	18.9	32.4	45.9	59.4	70.2	65.4	123	176	219
High Inertia (kgcm ²)		1.2	1.6	2.1	2.5	3.5	4.5	5.6	6.7	7.8	9.7	12.0	14.3	16.6	18.8	21.6	28.0	34.3	40.7	47.0	93.5	141	188	235
Standard Inertia (kgcm ²)		0.6	1.0	1.5	1.9	1.4	2.5	3.6	4.7	5.8	3.2	5.5	7.8	10.0	12.3	7.8	14.1	20.5	26.8	33.1	50.0	97.0	144	191
Winding Thermal Time Const.(sec)		81	74	94	100	172	168	183	221	228	175	185	198	217	241	213	217	275	301	365	240	242	319	632
Maximum Cogging (Nm)		0.02	0.03	0.04	0.05	0.03	0.06	0.08	0.10	0.13	0.06	0.10	0.14	0.18	0.21	0.09	0.16	0.23	0.30	0.35	0.30	0.54	0.72	0.99
Rated Speed 2000 (rpm)		Kt (Nm/A) 1.40 Ke (V/krpm) 85.5																						
Rated Torque (Nm)		1.1	2.1	3.0	3.8	2.2	4.0	5.5	6.9	8.2	3.2	6.1	8.7	10.8	14.0	5.9	10.3	14.6	18.4	21.3	20.0	36.9	50.4	▲
Continuous Stall Current (A)		0.9	1.6	2.3	2.8	1.7	3.1	4.3	5.4	6.5	2.6	4.8	6.8	8.9	11.0	4.6	7.8	11.0	14.2	16.8	15.7	29.5	42.1	
Rated Power (kW)		0.23	0.44	0.63	0.80	0.46	0.84	1.15	1.45	1.72	0.67	1.28	1.82	2.26	2.93	1.24	2.16	3.06	3.85	4.46	4.19	7.73	10.6	
R (ph-ph) (Ohms)		45.8	15.3	8.52	5.72	19.4	6.2	3.16	2.31	1.71	9.09	2.83	1.51	0.99	0.82	4.28	1.33	0.76	0.45	0.32	0.50	0.15	0.10	
L (ph-ph) (mH)		98.8	43.4	27.9	20.2	59.2	25.8	16.0	12.6	10.1	47.3	20.6	13.1	9.54	7.86	33.7	15.1	10.3	6.96	5.58	7.98	3.32	2.73	
Rated Speed 3000 (rpm)		Kt (Nm/A) 0.93 Ke (V/krpm) 57.0																						
Rated Torque (Nm)		1.1	2.0	2.8	3.5	2.0	3.9	5.4	6.8	8.1	3.0	5.5	8.1	10.4	12.6	5.4	9.0	12.2	15.8	N/A	19.2	33.0	▲	N/A
Continuous Stall Current (A)		1.3	2.4	3.4	4.2	2.5	4.7	6.4	8.1	9.7	3.8	7.1	10.2	13.4	16.5	6.8	11.7	16.5	21.3		23.5	44.2		
Rated Power (kW)		0.35	0.63	0.88	1.10	0.63	1.23	1.70	2.14	2.54	0.94	1.73	2.54	3.27	3.96	1.70	2.83	3.83	4.96		6.03	10.4		
R (ph-ph) (Ohms)		18.9	6.26	3.50	2.38	8.03	2.68	1.57	1.03	0.77	4.01	1.30	0.73	0.47	0.37	1.90	0.59	0.31	0.20		0.25	0.08		
L (ph-ph) (mH)		42.5	18.4	11.9	8.82	25.6	12.0	7.91	5.60	4.65	20.1	9.16	6.07	4.26	3.49	15.0	6.85	4.20	1.94		3.98	1.87		
Rated Speed 4000 (rpm)		Kt (Nm/A) 0.72 Ke (V/krpm) 44.0																						
Rated Torque (Nm)		1.0	1.7	2.3	2.9	1.8	3.0	4.0	4.9	5.7	2.5	4.7	6.3	7.5	▲	3.6	7.0	▲	N/A	N/A				
Continuous Stall Current (A)		1.7	3.1	4.4	5.5	3.3	6.0	8.3	10.5	12.6	4.9	9.2	13.1	17.3		8.8	15.1							
Rated Power (kW)		0.42	0.71	0.96	1.21	0.75	1.26	1.68	2.05	2.39	1.05	1.97	2.64	3.14		1.51	2.93							
R (ph-ph) (Ohms)		10.2	3.39	1.92	1.48	5.15	1.64	0.92	0.62	0.43	2.62	0.82	0.44	0.29		1.20	0.36							
L (ph-ph) (mH)		24.6	10.8	7.14	5.42	15.50	6.77	4.61	3.46	2.54	12.6	5.48	3.57	2.53		9.45	4.08							
Rated Speed 6000 (rpm)		Kt (Nm/A) 0.47 Ke (V/krpm) 28.5																						
Rated Torque (Nm)		0.9	1.6	2.1	2.6	1.3	2.1	2.8	3.3	▲	2.2	4.0	▲	N/A	N/A	2.9	▲	N/A	N/A	N/A				
Continuous Stall Current (A)		2.6	4.8	6.7	8.4	5.0	9.3	12.7	16.2		7.6	14.2				13.6								
Rated Power (kW)		0.57	1.01	1.32	1.63	0.82	1.32	1.76	2.07		1.38	2.51				1.82								
R (ph-ph) (Ohms)		4.49	1.49	0.95	0.65	2.01	0.67	0.35	0.26		0.96	0.30				0.49								
L (ph-ph) (mH)		10.7	4.73	3.10	2.33	6.41	3.01	1.77	1.40		4.80	2.09				3.96								

N/A Not available

▲ Consult factory

Control Techniques have an ongoing process of development and reserve the right to change the specification without notice.

75UMA300 Unimotor

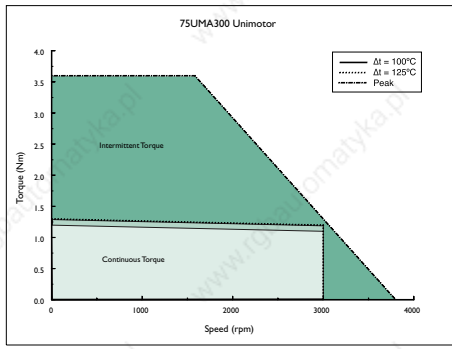

75UMB300 Unimotor

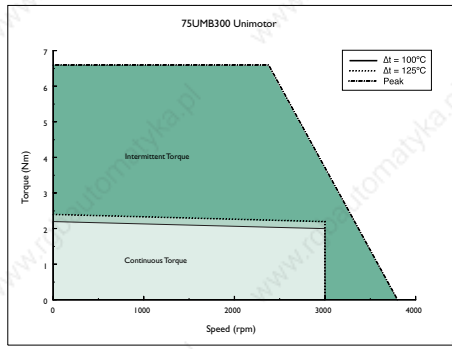

75UMC300 Unimotor

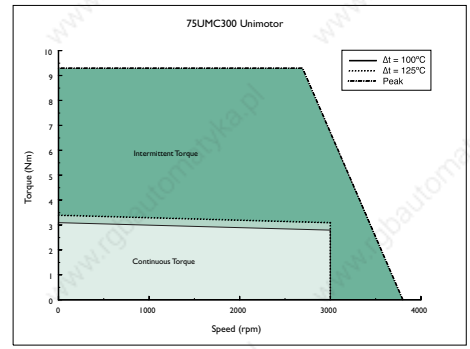

75UMD300 Unimotor

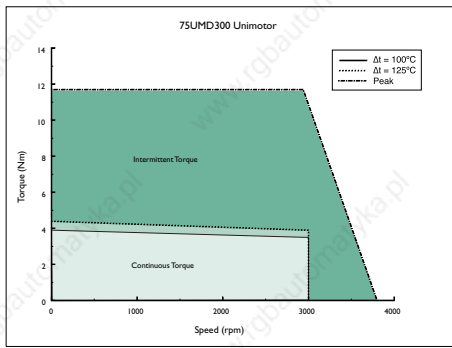

95UMA300 Unimotor

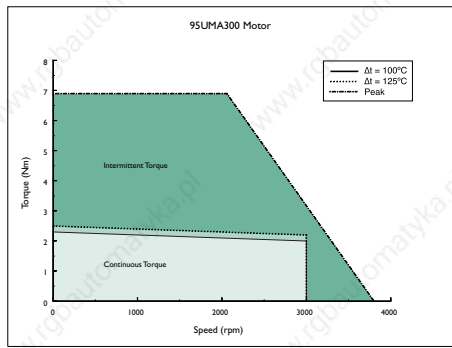

95UMB300 Unimotor

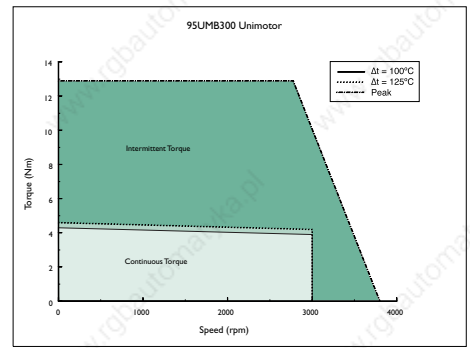

95UMC300 Unimotor

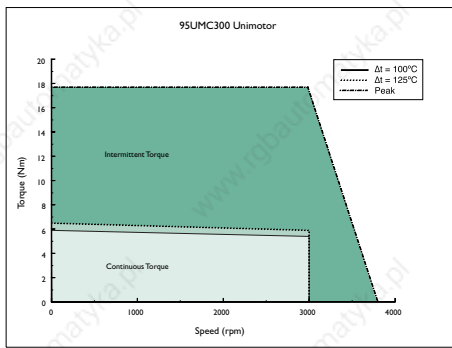

95UMD300 Unimotor

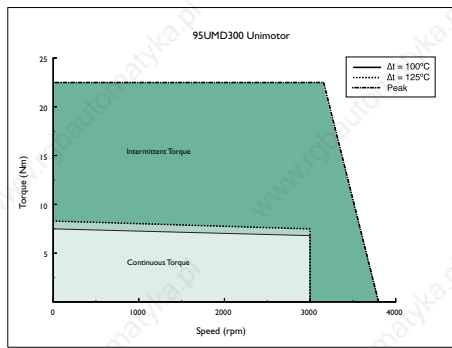

95UME300 Unimotor

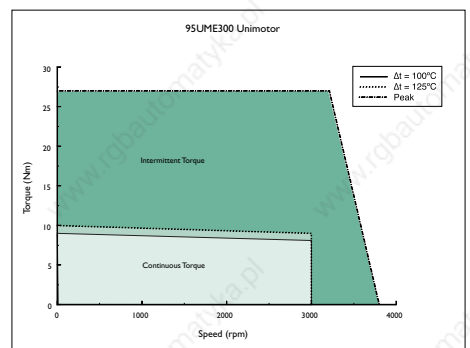

115UMA300 Unimotor

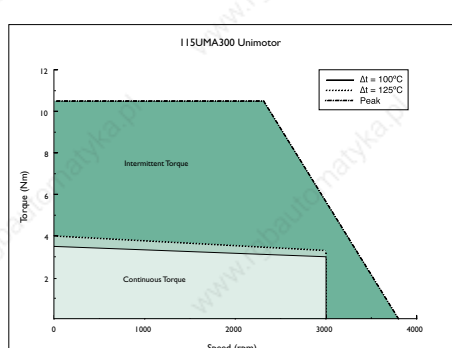

115UMB300 Unimotor

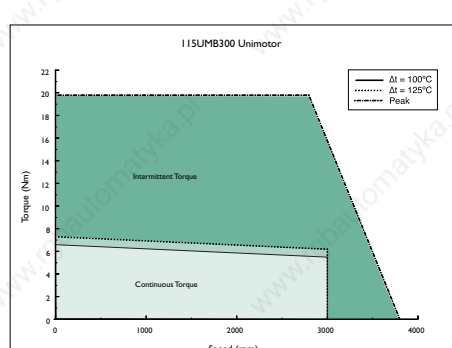

115UMC300 Unimotor

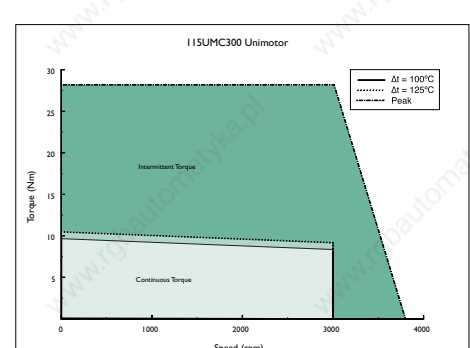

All graphs are at 40°C ambient and 400VAC drive supply.

CTD/IS/2000/01

UL and CAN/CSA Recognition marking for the Motor Insulation system USR and CNR Class 180(H) electrical insulation system designated "CTD/IS/2000/01".

The UL list number for this is E214439

Note: USR - United States Standards Recognised.

CNR - Canadian National Standards Recognised in accordance with CAN/CSA C22.2 No. 0-M91, Appendix B.

UL and CAN/CSA recognition marking for the Unimotor types UM; SL; EZ; DM.

This UL File number signifies recognition for the complete motor.

Note: Unimotors with Hybrid boxes for motor power connection and "S" special designated motors are not UL recognised and for these motors this mark will be excluded.

PERFORMANCE DEFINITIONS

Specifications differ for the UL motor only by presentation of the performance data in the tables and upon the motor label. Magnetic characteristics vary with motor temperature and the parameters shown are for worst case full rating in a 40 degrees C ambient, whereas for standard motors it has been conventional to quote nominal values for Kt and current. However, it should be noted that stall and rated torque have always been depicted as for worst case for both standard and now UL motor versions.

Unimotor UM and (SLM) (UL recog.) servo motor technical specifications For 3 Phase VPWM Drives 380-480 Vrms

Motor Frame Size (mm)		75				95					115					142					190				
All Speeds	Frame Length	A	B	C	D	A	B	C	D	E	A	B	C	D	E	A	B	C	D	E	A	B	C	D	
Continuous Stall Torque (Nm)		1.2	2.2	3.1	3.9	2.3	4.3	5.9	7.5	9.0	3.5	6.6	9.4	12.4	15.3	6.3	10.8	15.3	19.8	23.4	21.8	41.1	58.7	73.2	
Peak Torque (Nm)		3.6	6.6	9.3	11.7	6.9	12.9	17.7	22.5	27.0	10.5	19.8	28.2	37.2	45.9	18.9	32.4	45.9	59.4	70.2	65.4	123	176	219	
High Inertia (kgcm ²)		1.2	1.6	2.1	2.5	3.5	4.5	5.6	6.7	7.8	9.7	12.0	14.3	16.6	18.8	21.6	28.0	34.3	40.7	47.0	93.5	141	188	235	
Standard Inertia (kgcm ²)		0.6	1.0	1.5	1.9	1.4	2.5	3.6	4.7	5.8	3.2	5.5	7.8	10.0	12.3	7.8	14.1	20.5	26.8	33.1	50.0	97.0	144	191	
Winding Thermal Time Const.(sec)		81	74	94	100	172	168	183	221	228	175	185	198	217	241	213	217	275	301	365	240	242	319	632	
Maximum Cogging (Nm)		0.02	0.03	0.04	0.05	0.03	0.06	0.08	0.10	0.13	0.06	0.10	0.14	0.18	0.21	0.09	0.16	0.23	0.30	0.35	0.30	0.54	0.72	0.99	
Rated Speed 2000 (rpm)		Kt (Nm/A) 2.10 Ke (V/krpm) 129																							
Rated Torque (Nm)		1.1	2.1	3.0	3.8	2.2	4.0	5.5	6.9	8.2	3.2	6.1	8.7	10.8	14.0	5.9	10.3	14.6	18.4	21.3	20.0	36.9	50.4	54.7	
Continuous Stall Current (A)		0.6	1.0	1.5	1.9	1.1	2.0	2.8	3.6	4.3	1.7	3.1	4.5	5.9	7.3	3.0	5.1	7.3	9.4	11.1	9.6	18.2	26.0	32.4	
Rated Power (kW)		0.23	0.44	0.63	0.80	0.46	0.84	1.15	1.45	1.72	0.67	1.28	1.82	2.26	2.93	1.24	2.16	3.06	3.85	4.46	4.19	7.73	10.6	11.5	
R (ph-ph) (Ohms)		144	48.2	25.0	15.7	59.0	17.0	9.90	6.00	4.30	27.8	8.55	4.55	2.96	2.17	12.5	3.60	2.10	1.35	0.98	1.80	0.56	0.33	0.23	
L (ph-ph) (mH)		214	99.2	59.2	44.7	131	54.5	36.5	25.6	18.9	94.6	40.5	25.7	18.6	14.7	58.0	29.8	18.7	13.6	10.7	28.1	13.0	8.90	6.30	
Rated Speed 3000 (rpm)		Kt (Nm/A) 1.4 Ke (V/krpm) 85.8																							
Rated Torque (Nm)		1.1	2.0	2.8	3.5	2.0	3.9	5.4	6.8	8.1	3.0	5.5	8.1	10.4	12.6	5.4	9.0	12.2	15.8	18.0	19.2	33.0	35.0	36.8	
Continuous Stall Current (A)		0.9	1.6	2.2	2.8	1.6	3.1	4.2	5.4	6.4	2.5	4.7	6.7	8.8	10.9	4.5	7.7	10.9	14.1	16.7	14.5	27.3	39.0	48.6	
Rated Power (kW)		0.35	0.63	0.88	1.10	0.63	1.23	1.70	2.14	2.54	0.94	1.73	2.54	3.27	3.96	1.70	2.83	3.83	4.96	5.65	6.03	10.4	11.0	11.6	
R (ph-ph) (Ohms)		60.8	20.1	10.5	7.5	24.5	6.80	4.00	2.50	2.00	12.6	3.86	2.02	1.40	1.10	5.63	1.72	0.94	0.61	0.44	0.79	0.30	0.14	0.09	
L (ph-ph) (mH)		98.4	41.8	27.6	19.7	57.9	24.3	15.5	10.9	8.50	43.1	18.6	11.4	8.60	7.40	31.0	13.3	8.30	6.10	4.80	13.2	6.11	3.60	2.46	
Rated Speed 4000 (rpm)		Kt (Nm/A) 1.05 Ke (V/krpm) 64.4																							
Rated Torque (Nm)		1.0	1.7	2.3	2.9	1.8	3.0	4.0	4.9	5.7	2.5	4.7	6.3	7.5	8.7	3.6	7.0	8.9	10.7	12.2	▲	▲	▲	N/A	
Continuous Stall Current (A)		1.1	2.1	2.9	3.7	2.2	4.1	5.6	7.1	8.6	3.3	6.8	8.9	11.8	14.6	6.0	10.3	14.6	18.8	22.3					
Rated Power (kW)		0.42	0.71	0.96	1.21	0.75	1.26	1.68	2.05	2.39	1.05	1.97	2.64	3.14	3.64	1.51	2.93	3.73	4.48	5.11					
R (ph-ph) (Ohms)		36.8	10.5	6.30	4.20	12.7	4.08	2.10	1.50	1.03	6.91	2.14	1.16	0.73	0.57	3.12	1.00	0.53	0.35	0.24					
L (ph-ph) (mH)		54.9	24.8	14.9	10.8	31.5	13.6	8.50	6.30	4.80	23.5	10.2	6.60	4.70	3.90	17.6	7.50	4.70	3.60	2.70					
Rated Speed 6000 (rpm)		Kt (Nm/A) 0.70 Ke (V/krpm) 42.9																							
Rated Torque (Nm)		0.9	1.6	2.1	2.6	1.3	2.1	2.8	3.3	3.7	2.2	4.0	5.1	▲	N/A	2.9	4.5	▲	▲	N/A					
Continuous Stall Current (A)		1.7	3.1	4.4	5.6	3.3	6.1	8.4	10.7	12.8	5.0	9.4	13.4			9.0	15.4								
Rated Power (kW)		0.57	1.01	1.32	1.63	0.82	1.32	1.76	2.07	2.32	1.38	2.51	3.20			1.82	2.83								
R (ph-ph) (Ohms)		15.0	5.00	2.66	1.90	5.45	1.82	1.05	0.62	0.48	3.1	0.97	0.50			1.42	0.46								
L (ph-ph) (mH)		24.0	10.6	6.80	4.80	14.1	6.00	3.80	2.70	2.10	15.54	4.81	2.94			7.72	3.44								

N/A Not Available

▲ Consult factory

The information contained in this specification is for guidance only and does not form part of any contract. Control Techniques have an ongoing process of development and reserve the right to change the specification without notice.

For performance graphs see previous spread.

Unimotor EZ (UL recog.) servo motor technical specifications For 3 Phase VPWM Drives 200 - 240Vrms

Motor Frame Size (mm)		75				95					115					142					190			
All Speeds	Frame Length	A	B	C	D	A	B	C	D	E	A	B	C	D	E	A	B	C	D	E	A	B	C	D
Unimotors with Encoder Feedback $\Delta t = 100^{\circ}\text{C}$, 40°C ambient																								
		Stall torque; rated torque and power relate to maximum continuous operation in a 40°C ambient																						
		All data subject to +/-10% tolerance																						
Continuous Stall Torque (Nm)		1.2	2.2	3.1	3.9	2.3	4.3	5.9	7.5	9.0	3.5	6.6	9.4	12.4	15.3	6.3	10.8	15.3	19.8	23.4	21.8	41.1	58.7	73.2
Peak Torque (Nm)		3.6	6.6	9.3	11.7	6.9	12.9	17.7	22.5	27.0	10.5	19.8	28.2	37.2	45.9	18.9	32.4	45.9	59.4	70.2	65.4	123	176	219
High Inertia (kgcm^2)		1.2	1.6	2.1	2.5	3.5	4.5	5.6	6.7	7.8	9.7	12.0	14.3	16.6	18.8	21.6	28.0	34.3	40.7	47.0	93.5	141	188	235
Standard Inertia (kgcm^2)		0.6	1.0	1.5	1.9	1.4	2.5	3.6	4.7	5.8	3.2	5.5	7.8	10.0	12.3	7.8	14.1	20.5	26.8	33.1	50.0	97.0	144	191
Winding Thermal Time Const.(sec)		81	74	94	100	172	168	183	221	228	175	185	198	217	241	213	217	275	301	365	240	242	319	632
Maximum Cogging (Nm)		0.02	0.03	0.04	0.05	0.03	0.06	0.08	0.10	0.13	0.06	0.10	0.14	0.18	0.21	0.09	0.16	0.23	0.30	0.35	0.30	0.54	0.72	0.99
Rated Speed 2000 (rpm)		K_t (Nm/A) 1.22 K_e (V/krpm) 75.0																						
Rated Torque (Nm)		1.1	2.1	3.0	3.8	2.2	4.0	5.5	6.9	8.2	3.2	6.1	8.7	10.8	14.0	5.9	10.3	14.6	18.4	21.3	20.0	36.9	50.4	▲
Continuous Stall Current (A)		1.0	1.8	2.5	3.2	1.9	3.5	4.8	6.1	7.4	2.9	5.4	7.7	10.1	12.5	5.2	8.8	12.5	16.2	19.1	16.6	31.3	44.7	
Rated Power (kW)		0.23	0.44	0.63	0.80	0.46	0.84	1.15	1.45	1.72	0.67	1.28	1.82	2.26	2.93	1.24	2.16	3.06	3.85	4.46	4.19	7.73	10.6	
R (ph-ph) (Ohms)		45.8	15.3	8.52	5.72	19.4	6.2	3.16	2.31	1.71	9.09	2.83	1.51	0.99	0.82	4.28	1.33	0.76	0.45	0.32	0.50	0.15	0.10	
L (ph-ph) (mH)		98.8	43.4	27.9	20.2	59.2	25.8	16.0	12.6	10.1	47.3	20.6	13.1	9.54	7.86	33.7	15.1	10.3	6.96	5.58	7.98	3.32	2.73	
Rated Speed 3000 (rpm)		K_t (Nm/A) 0.82 K_e (V/krpm) 49.9																						
Rated Torque (Nm)		1.1	2.0	2.8	3.5	2.0	3.9	5.4	6.8	8.1	3.0	5.5	8.1	10.4	12.6	5.4	9.0	12.2	15.8	N/A	19.2	33.0	▲	N/A
Continuous Stall Current (A)		1.5	2.7	3.8	4.8	2.8	5.3	7.2	9.2	11.0	4.3	8.1	11.5	15.2	18.8	7.7	13.2	18.8	24.3		24.9	46.9		
Rated Power (kW)		0.35	0.63	0.88	1.10	0.63	1.23	1.70	2.14	2.54	0.94	1.73	2.54	3.27	3.96	1.70	2.83	3.83	4.96		6.03	10.4		
R (ph-ph) (Ohms)		18.9	6.26	3.50	2.38	8.03	2.68	1.57	1.03	0.77	4.01	1.30	0.73	0.47	0.37	1.90	0.59	0.31	0.20		0.25	0.08		
L (ph-ph) (mH)		42.5	18.4	11.9	8.82	25.6	12.0	7.91	5.60	4.65	20.1	9.16	6.07	4.26	3.49	15.0	6.85	4.20	1.94		3.98	1.87		
Rated Speed 4000 (rpm)		K_t (Nm/A) 0.63 K_e (V/krpm) 38.5																						
Rated Torque (Nm)		1.0	1.7	2.3	2.9	1.8	3.0	4.0	4.9	5.7	2.5	4.7	6.3	7.5	▲	3.6	7.0	▲	N/A	N/A				
Continuous Stall Current (A)		1.9	3.5	4.9	6.2	3.7	6.8	9.4	11.9	14.3	5.6	10.5	14.9	19.7		10.0	17.2							
Rated Power (kW)		0.42	0.71	0.96	1.21	0.75	1.26	1.68	2.05	2.39	1.05	1.97	2.64	3.14		1.51	2.93							
R (ph-ph) (Ohms)		10.2	3.39	1.92	1.48	5.15	1.64	0.92	0.62	0.43	2.62	0.82	0.44	0.29		1.20	0.36							
L (ph-ph) (mH)		24.6	10.8	7.14	5.42	15.50	6.77	4.61	3.46	2.54	12.6	5.48	3.57	2.53		9.45	4.08							
Rated Speed 6000 (rpm)		K_t (Nm/A) 0.41 K_e (V/krpm) 25.0																						
Rated Torque (Nm)		0.9	1.6	2.1	2.6	1.3	2.1	2.8	3.3	▲	2.2	4.0	▲	N/A	N/A	2.9	▲	N/A	N/A	N/A				
Continuous Stall Current (A)		2.9	5.4	7.6	9.6	5.6	10.6	14.5	18.4		8.6	16.2				15.5								
Rated Power (kW)		0.57	1.01	1.32	1.63	0.82	1.32	1.76	2.07		1.38	2.51				1.82								
R (ph-ph) (Ohms)		4.49	1.49	0.95	0.65	2.01	0.67	0.35	0.26		0.96	0.30				0.49								
L (ph-ph) (mH)		10.7	4.73	3.10	2.33	6.41	3.01	1.77	1.40		4.80	2.09				3.96								

N/A Not available

▲ Consult factory

Control Techniques have an ongoing process of development and reserve the right to change the specification without notice.

For performance graphs see previous spread.

OUTLINE DRAWINGS - FRAME SIZES 75 - 190

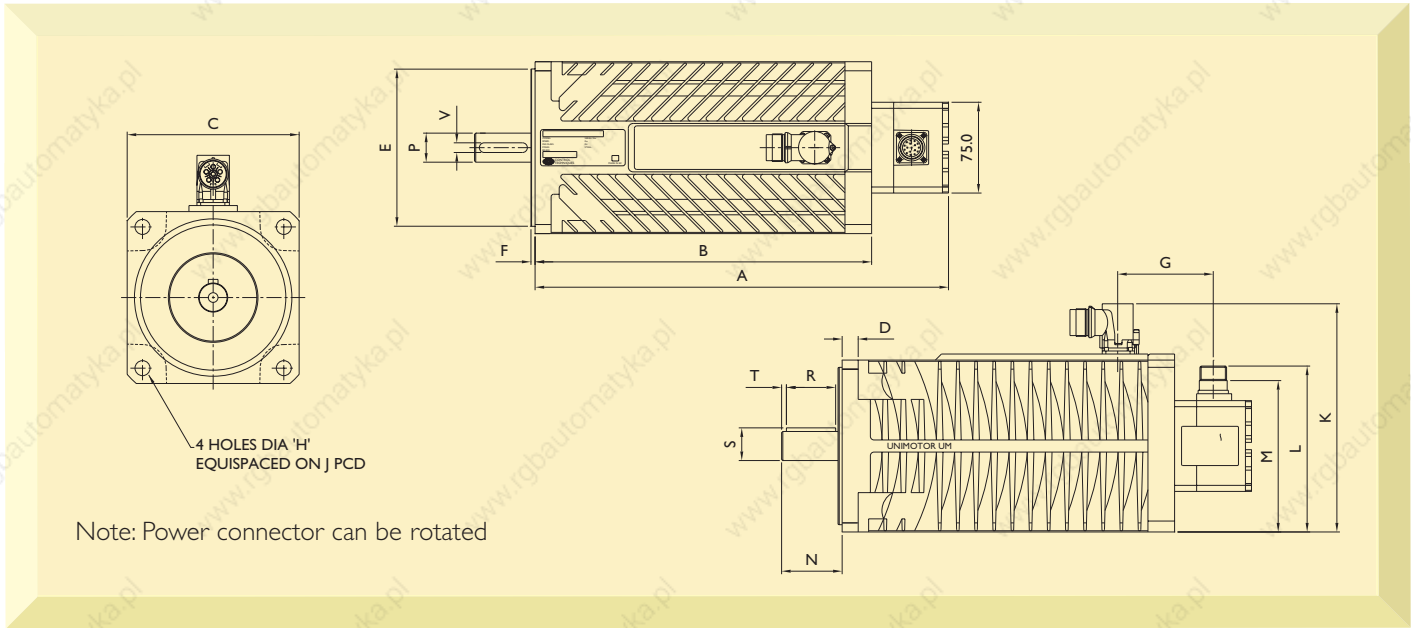

DIMENSIONS (mm)

Dimensions - Frame Sizes 75 - 190 (Note: Overall dimensions shown are maximum values)

Frame size	75				95					115					142					190			
Dimension / Length suffix	A	B	C	D	A	B	C	D	E	A	B	C	D	E	A	B	C	D	E	A	B	C	D
A Length Overall (Unbraked)	211	241	271	301	222	252	282	312	342	242	272	302	332	362	225	255	285	315	345	273	327	381	435
A Length Overall (Braked)	241	271	301	331	252	282	312	342	372	272	302	332	362	392	285	315	345	375	405	327	381	435	489
B Body Length (Unbraked)	146	176	206	236	157	187	217	247	277	177	207	237	267	297	160	190	220	250	280	210	264	318	372
B Body Length (Braked)	176	206	236	266	187	217	247	277	307	207	237	267	297	327	220	250	280	310	340	264	318	372	425
C Flange Square	75.0				95.0					115.0					142.0					190.0			
D Flange Thickness	7.0				9.0					11.0					12.3					14.5			
E Register Diameter	60.0 (J6)				80.0 (J6)					95.0 (J6)					130.0 (J6)					180.0 (J6)			
F Register Length	2.4				2.9					2.9					3.4					4.0			
G Power to Connect C/L	61.0				62.5					66.0					80.0					14.5 (H14)			
H Fixing Holes Diameter	5.8 (H14)				7.0 (H14)					10.0 (H14)					12.0 (H14)					215.0			
J Fixing Hole p.c.d.	75.0				100.0					115.0					165.0					260.0			
K Overall Height	126.0				146.0					166.0					193.0					161.1			
L Signal Connector Height (UM)	107.0				117.0					127.0					140.0					58.0			
M Signal Connector Height (SL)	88.0				98.0					108.0					121.0					32.0(K6)			
N Shaft Length (front)	23.0	30.0	30.0	30.0	30.0	40.0	40.0	40.0	40.0	40.0	40.0	40.0	50.0	50.0	50.0	50.0	50.0	50.0	50.0	58	58	58	58
P Shaft Diameter (J6)	11.0	14.0	14.0	14.0	14.0	19.0	19.0	19.0	19.0	19.0	19.0	19.0	24.0	24.0	24.0	24.0	24.0	24.0	24.0	32	32	32	32
Shaft Key Dimensions																							
(option A)																							
R Key Length	14.0	22.0	22.0	22.0	22.0	32.0	32.0	32.0	32.0	32.0	32.0	32.0	40.0	40.0	40.0	40.0	40.0	40.0	40.0	49.0			
S Key Height	12.4	15.9	15.9	15.9	15.9	21.4	21.4	21.4	21.4	21.4	21.4	21.4	26.9	26.9	26.9	26.9	26.9	26.9	26.9	35.0			
T Key to Shaft End	3.5	3.0	3.0	3.0	3.0	3.0	3.0	3.0	3.0	3.0	3.0	3.0	4.0	4.0	4.0	4.0	4.0	4.0	4.0	3.1			
V Key Width	4.0	5.0	5.0	5.0	5.0	6.0	6.0	6.0	6.0	6.0	6.0	6.0	8.0	8.0	8.0	8.0	8.0	8.0	8.0	10.1			
Typical Weight (Kg)																							
Low Inertia	3.5	4.3	5.1	5.8	4.7	6.1	7.3	8.8	10.2	7.3	8.9	10.6	12.5	14.2	9.4	12.1	14.7	17.6	20.3	23.2	32.0	40.8	49.5
Low Inertia (braked)	3.9	4.8	5.4	6.3	5.3	6.7	7.9	9.4	10.8	8.5	10.1	11.8	13.7	15.4	11.2	13.9	16.5	19.4	22.1	25.2	34.0	42.8	51.5
High Inertia	3.7	4.6	5.6	6.1	5.6	7.0	8.2	9.7	11.1	8.2	9.8	11.5	13.4	15.1	11.7	14.4	17.0	19.9	22.6	25.5	34.3	43.3	52.0
High Inertia (braked)	4.2	5.1	5.9	6.6	6.2	7.6	8.8	10.3	11.7	9.4	11.0	12.7	14.6	16.3	13.5	16.2	18.8	21.7	24.4	27.6	36.3	45.3	54.0

FEEDBACK DEVICES

Feedback is the essence of a servo system.





High quality servo performance depends upon the rigidity of the mechanics of the servo system to permit high servo gains and bandwidth without resonance and instability, and upon the resolution and accuracy of the feedback device.

The Unimotor offers selection of feedback types suitable for use with the Unidrive  or the M'Ax and MultiAx drives.

The Unidrive  has an incremental encoder interface as standard, but with a suitable optional interface to resolver or sincos (single or multi-turn) types.

The M'Ax and MultiAx drives operate with the SL motors with a special sincos-based 'CT-Coder' and built-in  electronics.

Feedback type should be chosen to suit the particular application, and the table below summarises the considerations.

Feedback type	Motor types	Motor Δt °C	Feedback Resolution	Positional Accuracy	Absolute / Non-Volatile?	Multi-turn available?	Comments
Resolver	UM	125	1.3 arc min	40 min 16384/ rev spread	Yes	No	Use for Unidrive  option module for high temp / harsh environment
Incremental optical encoder 4096 ppr in quadrature	UM to 3000rpm	100	1.3 arc min 16384/ rev	+/-60 sec	No	No	Suits most applications. Low speed control down to 1rpm 300kHz b/w
Incremental optical encoder 2048 ppr in quadrature	UM to 3000rpm	100	2.6 arc min 8192 / rev	+/-60 sec	No	No	Suits most applications. Low speed control down to 1rpm 300kHz b/w
Sincos optical encoder 1024 cycles/rev	UM	100	0.3 arc sec 2.097 $\times 10^6$ / rev 1 $\times 10^5$ / rev best in practice	+/-52 sec	Yes	Yes	Use for high resolution with Unidrive  , Analogue signal is susceptible to noise distortion. Low speed control below 1rpm Better stability when load / motor inertia match is poor. Multi-turn counts 0 to 4096 max
 optical 'CT-Coder' 1024 cycles/rev	SL	100	0.16 arc sec 8×10^6 / rev	+/-52sec	Yes Limited position at start up Not multi-turn	No	Use for highest resolution with M'Ax or MultiAx drives. Interpolation at motor and digital link to drive using  technology. Better stability when load / motor inertia match is poor.

FAIL SAFE PARKING BRAKES

Any Unimotor may optionally be ordered with an internal rear mounted parking brake. The brake works on a fail safe principle: the brake is active when the supply voltage is switched off and the brake is released when the supply voltage is switched on. The table below shows the delay times that occur when the brake is switched on or off. Shunting the brake with an external diode to avoid switching peaks increases the coil's decay time considerably.

If a motor is fitted with a fail safe brake, take care not to expose the motor shaft to excessive torsional shocks or resonances when the brake is engaged or disengaged. Doing so can damage the brake.

SAFETY NOTE: The Fail-Safe Brake is for use as a holding brake with the motor shaft stationary. Do NOT use it as a dynamic brake, except for emergencies such as a mains supply failure.

Technical Data

MOTOR FRAME SIZE	VOLTS	POWER	STATIC TORQUE	RELEASE TIME (Coil Energised)	BRAKE ON-TIME (Coil de-energising no diode)	BRAKE ON-TIME (Coil de-energising with diode)	INERTIA	BACKLASH
(mm)	DC	W	(Nm)	(ms nominal)	(ms nominal)	(ms nominal)	(kgcm ²)*1	(degrees)
75	24	6.3	2	22	24	100	0.03	0.75
95	24	16	6	30	20	140	0.29	0.75
115	24	16	12	40	10	60	0.49	0.75
142	24	23	20	85	30	200	1.28	0.6
190(A/B)	24	25	40	95	15	85	1.28	0.6
190(C/D)	24	25	60	120	20	150	2.50	0.6

*1 1kgcm² = 1x10⁻⁴kgm²

Note that the brake response time is extended when a diode is fitted across the brake coil at the driver (customer) end. This is usually required to protect solid state switches, or to reduce arcing at the relay contacts

SERVO GEARBOXES

Although Unimotors can operate smoothly at full torque from 1 rpm (sincos and SL - from small fractions of rpm) to full rated speed, the addition of a gearbox can be a useful torque multiplier and can also provide a better match to high inertia loads.

A Gearbox May Help If:-

- Load is high torque, usually below 1000rpm
- Load is high inertia
- Load has unusually high axial or radial loads
- Small overall size with small motor
- Possible cost reduction with smaller motor & drive package
- Space constraints where right angle option or smaller overall package helps

For example:-

- A 1.2Nm 4000rpm motor fitted with 100:1 ratio gearbox gives a continuous torque around 100Nm, albeit at a reduced speed of 40rpm max.
- A 4,000rpm motor with a 4:1 gearbox in certain circumstances may offer a better performance than a 2,000rpm motor alone working at 1000rpm with large inertial load. The motor torque required for the gearbox is 3 to 4 times less, whilst the reflected load inertia is reduced by 16 ($=\text{ratio}^2$), so that a better match of motor/load inertia results and greater stability with higher servo gains are possible.

What's Available:-

Control Techniques offers a range of gearboxes supplied fitted to any Control Techniques motor (55 to 190 frame sizes).

If required, gearboxes can also be supplied separately.

By following a simple selection procedure, a suitable motor-gearbox combination may be selected from specifications provided in this section.

Gearbox specifications appended to this section are quality planetary gearboxes and include low backlash, standard backlash, single-stage, and two-stage with ratios up to 100:1.

Gearboxes with 90 degree angled output shafts can increase the possible ratio permutations up to 200:1.

The gearbox output shaft can optionally be fitted with key.

The motor-gearbox assembly comprises of the gearbox, an integral gearbox adaptor plate, and a standard Control Techniques motor:

The motor-gearbox assembly is normally supported from the front face / flange of an in-line gear reducer. For a right angled gearbox, the mounting support is also to the gearbox flange, but for the others, mounting support is to the gearbox frame.

Features – Gearboxes

- High quality, low backlash, low noise
- Taper bearings
- Wide selection
- Planetary gearboxes for high efficiency and low inertia
- High strength
- Long service life
- Ratios to suit application consult drive centre
- Lifetime lubrication to suit any mounting attitude
- Gearbox IP64 protection rating
- To suit all 55 to 190 UM, SL, & EZ motors

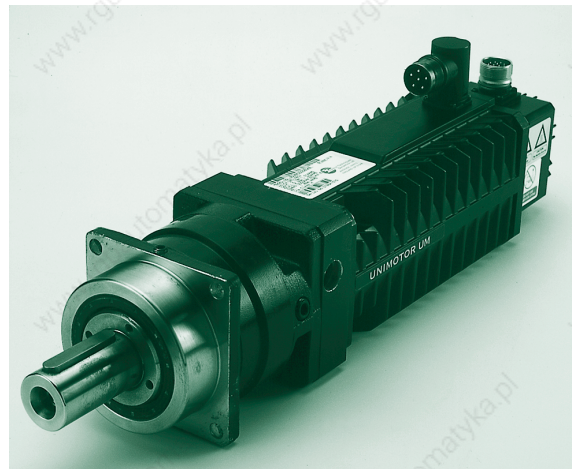

Gearbox Styles & Types

Gearbox parameters for various manufacturers and gearbox types are included at the end of the gearbox section. From this and the information below, select a gearbox type to suit requirements, including backlash. Reduced backlash is available by special request only where indicated.

POWER AND SIGNAL CABLES



Cables are an important part of a servo system installation. Not only must the noise immunity and integrity of the cabling and connectors be correct, but also SAFETY and EMC regulations must be complied with to ensure successful, reliable and fail-safe operation. One of the most frequent problems experienced by motion systems engineers is incorrect wiring connection of the motor to the drive.

Control Techniques ready-made cables mean system installers can avoid the intricate, time consuming assembly normally associated with connecting servo systems. Installation and set-up time are greatly reduced - there is no fiddling with wire connections and crimp tools, and no fault finding.

The cables are made to order in lengths from 2m to 50m / 100m.

Cable Range

Cable range for motor-drive combinations:

- UM & Unidrive 
-  and M'Ax or MultiAx
- EZ & Unidrive  (200V)
- EZ & Epsilon
- MM & MiniAx

Power cable variants:

- Phase conductors 1.5mm² (16A) to 16mm² (70A)
- With and without brake wire pairs
- Motor end - Connector
- Motor end - Hybrid (power terminal box)
- Tailored to suit drive (ferrules; strands; ring terminals)

Signal cable feedback types:

- Incremental
- Resolver
- SinCos
- 
- Cable tailored to suit drive (ferrules; connectors)
- M'Ax to M'Ax Drive interconnects available



PUR Cable Features

- Dynamic performance
- PUR outer sheath for oil resistance and dynamic performance
- Complies with DESINA coding - Orange for power, green for signal
- Power cable and plugs UL recognised
- Optimum noise immunity
- Shielded brake supply wires
- UM Encoder cable has low volt drop for long cable lengths and separately screened thermistor wires
- Brake wires are separately shielded within power cable
- No need for crimp and insertion / removal tools
- Production build gives quality and price benefits
- Compatible with wide range of Control Techniques motors and drives
- Braided screen for greater flexibility and wear
- Power cables with or without brake wires
- Cable assembly type identification label

Cables with Designer Colours (Power = Orange, Signal = Green)

Power

Phase & Conductor Size	Unimotor size power plug size	Current rating	Overall cable diameter (mm) No brake	Overall cable diameter (mm) braked
G - 1.5mm ² (16A)	75-142 size I	30A sockets	10.2	12.0
A - 2.5mm ² (22A)	75-142 size I	30A sockets	11.8	12.8
B - 4.0mm ² (30A)	75-142 size I 190 size 1.5	30A sockets 53A sockets	14.4	14.4
C - 6.0mm ² (37A)	190 size 1.5	70A sockets	17.4	17.4
D - 10.0mm ² (52A)	190 size 1.5	70A sockets	20.4	20.4
E - 16.0mm ² (70A)	190 size 1.5	70A sockets	23.4	23.4
F - 1mm ² (Unscreened)	DS Brake			

Note: minimum bend radius = 10 x dia

Signal

Drive Type	Motor Type	Cable Type
Unidrive 	UM	Encoder SI: SinCos SS: Resolver SR
M'Ax / MultiAx	SL	Speed Loop Module SL
Epsilon / EN /	EZ	Encoder SI: Resolver SR
MiniAx	MM	Encoder SI

Signal – Basic Cable Types

Cable Type	Cable Code	Cable diameter (mm)
Encoder	SIBA	10.9
Resolver / SinCos	SRBA/SSBA	9.6
SLM	SLBA	6.2
Low Cost Encoder	SIBL	8.5

SELECTING POWER CABLES

Cable type – PS for motor without brakes, PB for motors with brake.

Jacket – B is for a PUR sheath and is the standard selection. A is for a PVC sheath to be used on the DS brake cable only.

Conductor Size – Select the conductor size according to the motors STALL CURRENT.

Include forced cooling performance if applicable.

Cables of 6mm² and above will be fitted with ring terminals only.

Ratings are for individual cables (not lashed together) in free air temperature up to 40°C – make allowances as appropriate.

Connection detail drive end – Select the correct drive end connection for the drive in use.

Connection detail motor end – Select the correct motor end connection for the motor in use.

Length – Numbers represent the required cable length in metres. Conversion cables will be limited to 0.4m only and the length is not required in the order code.

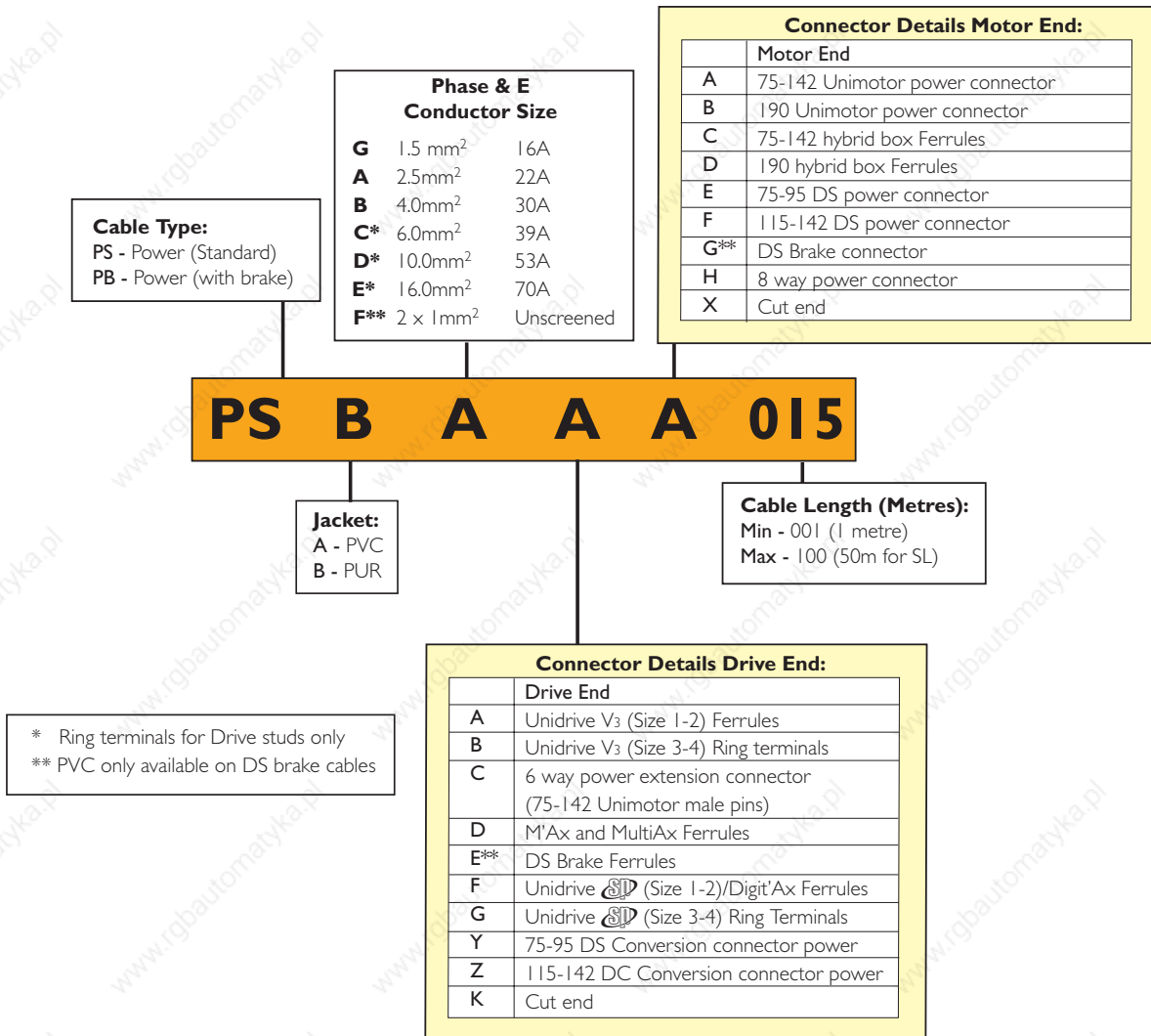

POWER CABLE EXAMPLES

PBBXDA

M'Ax Power Cable with brake wires

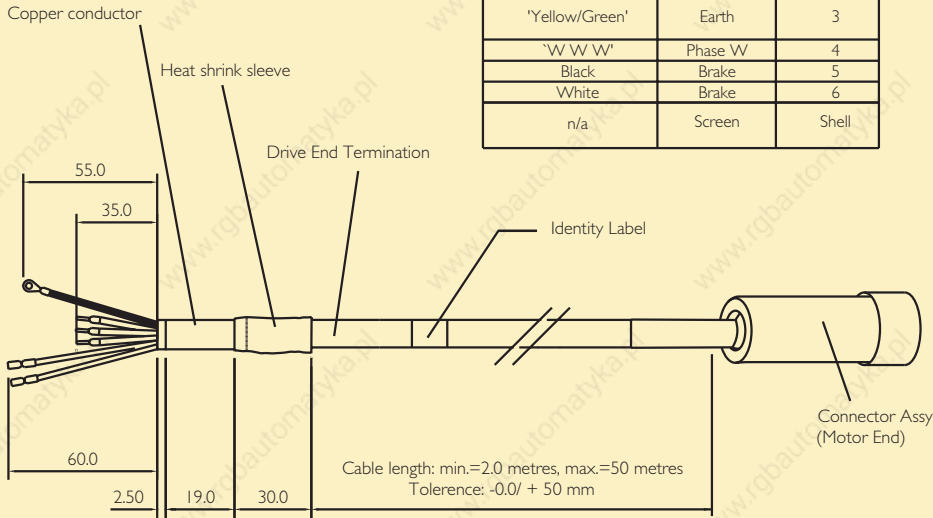

DRIVE END	MOTOR END	
	Function	Pin
PUR Conductor		
'U'	Phase U	1
'V V'	Phase V	2
'Yellow/Green'	Earth	3
'W W W'	Phase W	4
Black	Brake	5
White	Brake	6
n/a	Screen	Shell

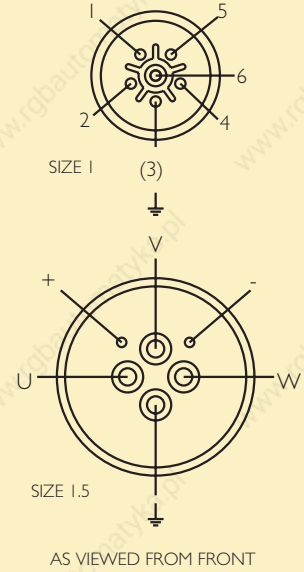

PSBXAB

UM Power Cable without brake wires

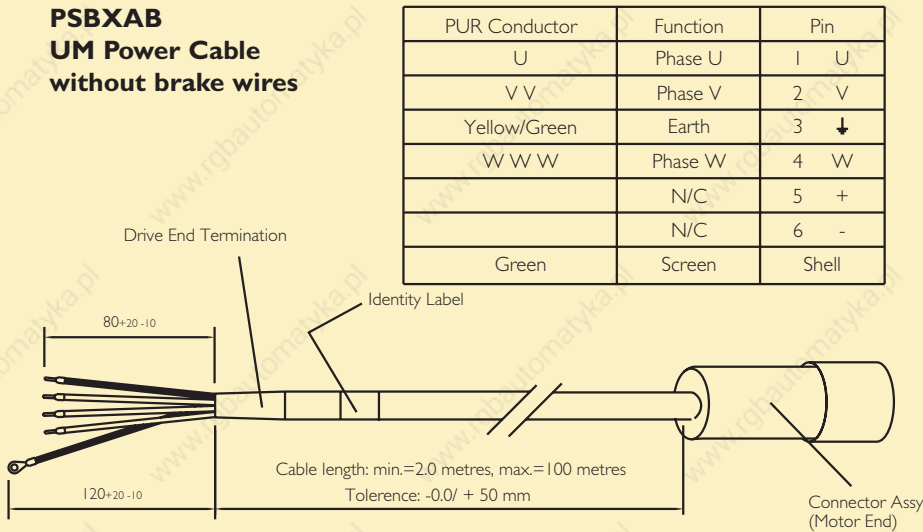

PUR Conductor	Function	Pin
U	Phase U	1 U
V V	Phase V	2 V
Yellow/Green	Earth	3 ↓
W W W	Phase W	4 W
	N/C	5 +
	N/C	6 -
Green	Screen	Shell

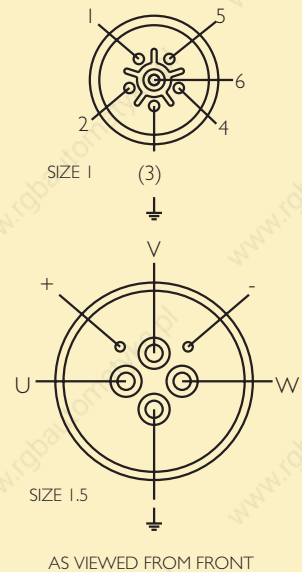

SELECTING SIGNAL CABLES

Cable type – Choose the cable type to match the feedback device.

Jacket – B is for a PUR sheath and is the standard selection.

Special options – A is for standard cable. L is for the low cost 8.5mm incremental cable.

Connection detail drive end – Select the correct drive end connection for the drive in use.

Connection detail motor end – Select the correct motor end connection for the motor feedback device in use.

Length – Numbers represent the required cable length in metres. Conversion cables will be limited to 0.4m only and the length is not required in the order code.

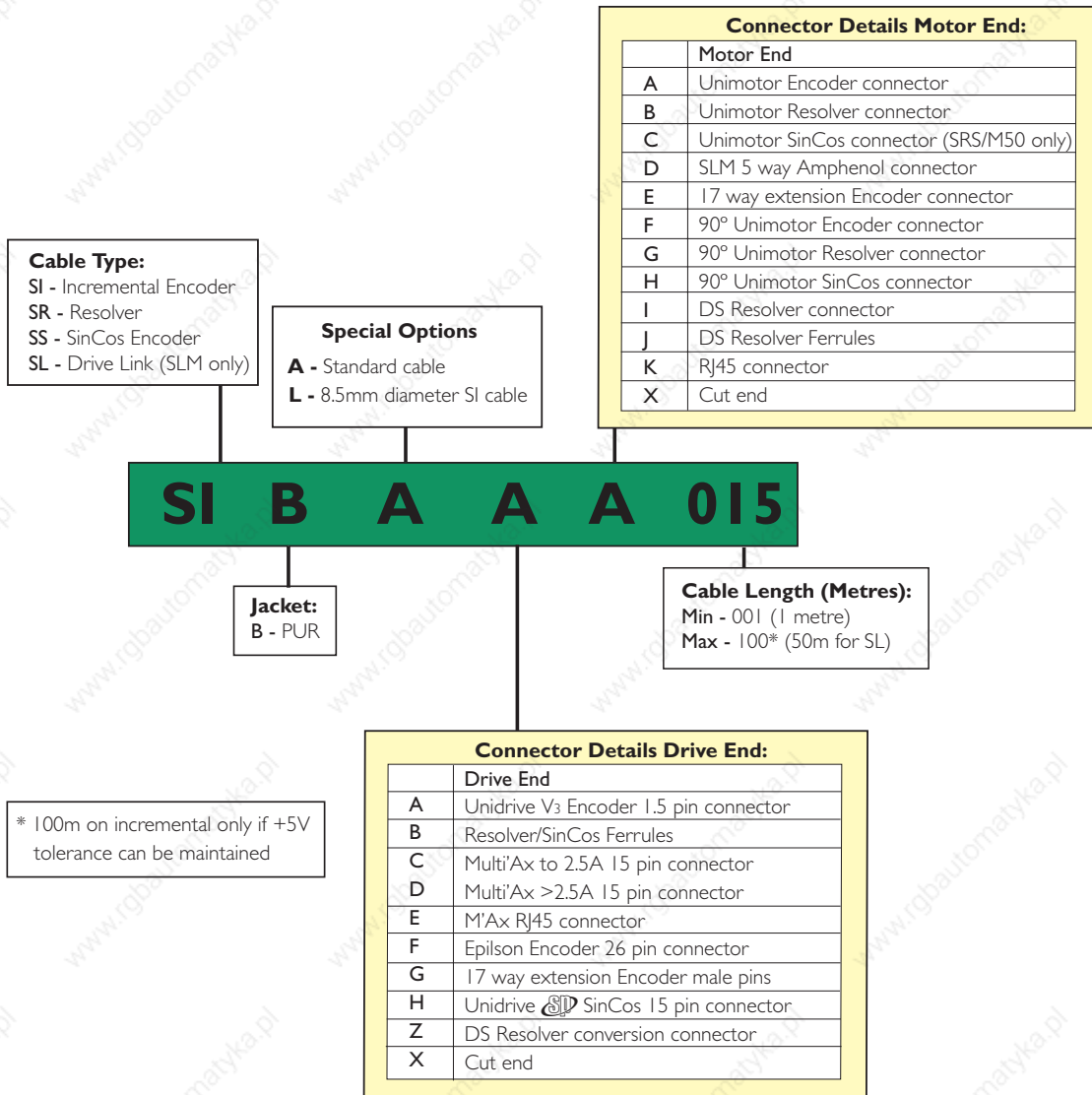

SIGNAL CABLE EXAMPLES

SSIBXAA Incremental Signal Cable (Unidrive)

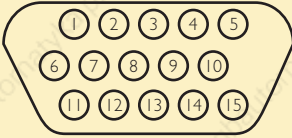

Viewed from front
Drive End Termination
15 pin 'D' type Connector

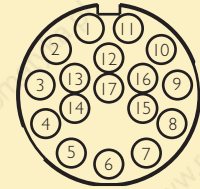
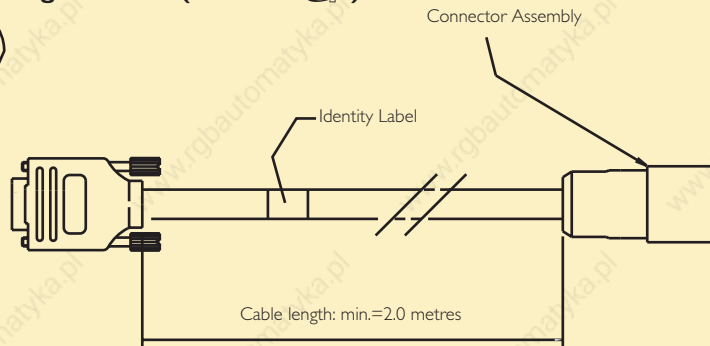

Viewed from front

INCREMENTAL CABLE - SIBAx_x, dia 10.9, length 100m max.

SIBL_{xx}, dia 8.5mm, length 10m max.

15 WAY 'D' Type Connector		
Pin	Colour	Function
1	Grey / Pink Band	Channel A
2	Red / Blue Band	Channel A Inverse
3	Red (0.34mm ²)	Channel B
4	Blue (0.34mm ²)	Channel B Inverse
5	White / Green Band	Index
6	Brown / Green Band	Index Inverse
7	Green	S1
8	Yellow	S1 Inverse
9	Grey	S2
10	Pink	S2 Inverse
11	Black	S3
12	Purple	S3 Inverse
13	Red (1mm ²)	+5V dc
14	Blue (1mm ²) + White	0V + Thermistor
15	Brown	Thermistor signal
-		
-		
BODY	Thermistor screen & overall screen	

17 WAY MOTOR SIGNAL PLUG		
Pin	Colour	Function
1	White	Thermistor 0V
2	Brown	Thermistor signal
3	Orange	Screen
4	Green	S1
5	Yellow	S1 Inverse
6	Grey	S2
7	Pink	S2 Inverse
8	Black	S3
9	Purple	S3 Inverse
10	Grey / Pink Band	Channel A
11	White / Green Band	Index
12	Brown / Green Band	Index Inverse
13	Red / Blue Band	Channel A Inverse
14	Red (0.34mm)	Channel B
15	Blue (0.34mm)	Channel B Inverse
16	Red (1.0mm)	+5V dc
17	Blue (1.0mm)	0 Volts
Body	Screen	Screen

SSBSBC SinCos Signal Cable (Unidrive)

Note: SSBAHC – Sincos cable for Unidrive is similar but has 15 way D type connector at drive end

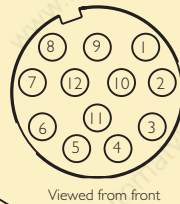
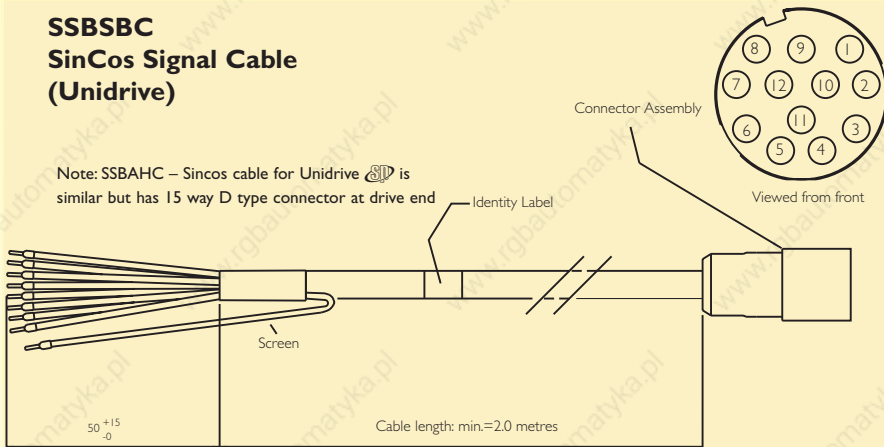

Viewed from front

INTERCONNECTRON 12 WAY		
Pin	Colour	Function
1	RED	REF Cos
2	BLUE	+ DATEN
3	VIOLET	- DATEN
4	ORANGE	+ Cos
5	BROWN	+Sin
6	BLACK	REF Sin
7	YELLOW	THERMISTOR
8	GREEN	THERMISTOR
9	SCREEN	SCREEN
10	BLUE/WHITE	0 VOLTS
11	-	-
12	RED/WHITE	+ VOLTS

SSBABH SinCos Signal Cable (Unidrive) with 90 Deg Connector

Note: dimension 50mm of wire ends may be shortened to better accommodate the Unidrive SP

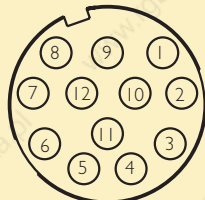
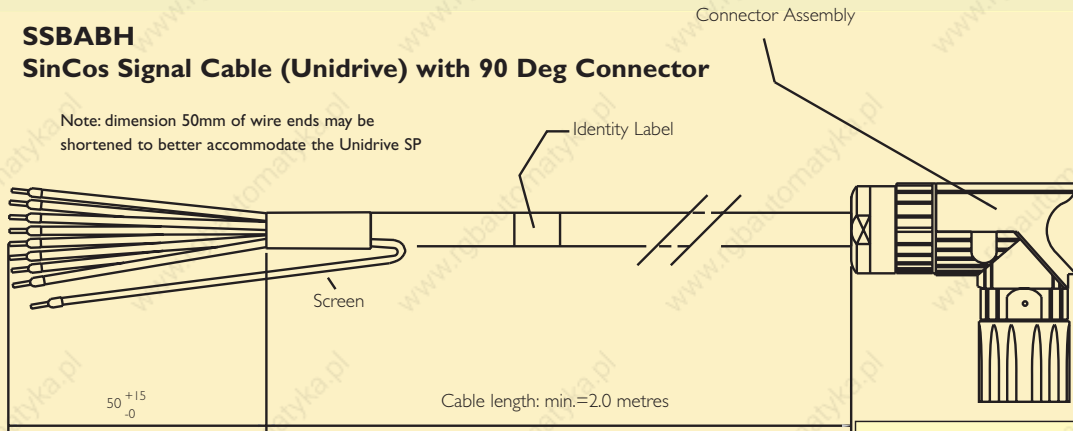

INTERCONNECTRON 12 WAY

Pin	Colour	Function
1	RED (0.38mm ²)	REF Cos
2	BLUE (0.38mm ²)	+ DATEN
3	VIOLET	- DATEN
4	ORANGE	+ Cos
5	BROWN	+Sin
6	BLACK	REF Sin
7	YELLOW	THERMISTOR
8	GREEN	THERMISTOR
9	SCREEN	SCREEN
10	BLUE (0.5mm ²)	0 VOLTS
11	-	-
12	RED (0.5mm ²)	+ VOLTS

SRBxBB Resolver Signal Cable (Unidrive/Unidrive SP)

Note: dimension 50mm of wire ends may be shortened to better accommodate the Unidrive SP

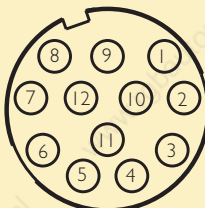
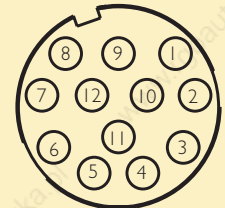
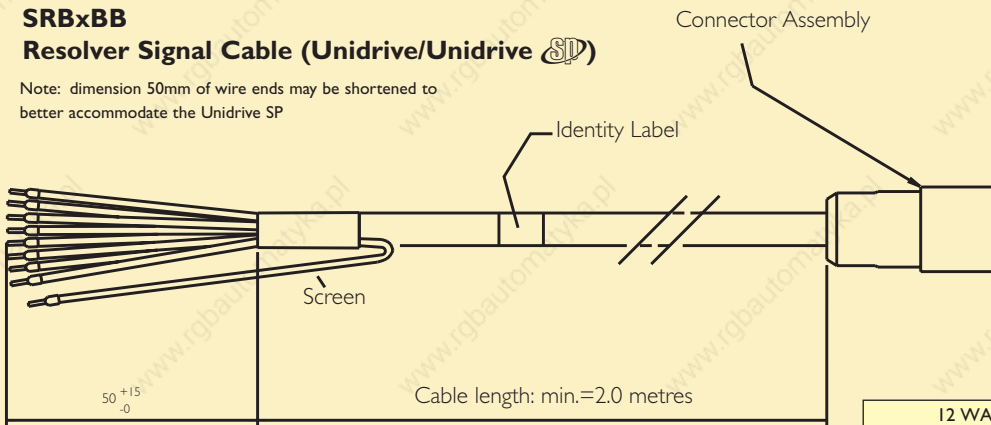

12 WAY MOTOR SIGNAL PLUG

Pin	Colour	Function
1	RED	EXCITATION HIGH
2	ORANGE	EXCITATION LOW
3	BLUE	COSINE HIGH
4	VIOLET	COSINE LOW
5	BROWN	SINE HIGH
6	BLACK	SINE LOW
7	YELLOW	THERMISTOR
8	GREEN	THERMISTOR
9	-	-
10	-	-
11	-	-
12	-	-
Body	SCREEN	SCREEN

SLBAED SLM Signal Cable (M'Ax)

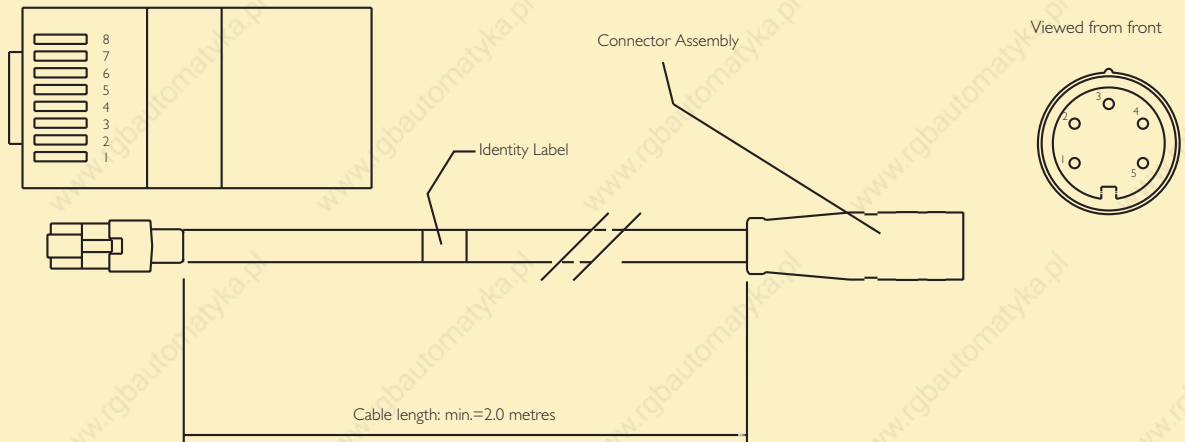

Connection details			PUR	PVC
RJ45	Amphenol	Function	Colour	Colour
2	1	COMM	BROWN	ORANGE
1	5	COMM	WHITE	WHITE/ORANGE
5	3	+24V	YELLOW	WHITE/GREEN
6	2	0V	GREEN	GREEN
BODY	4 + BODY	SCREEN	SCREEN	SCREEN

SLBACD SLM Signal Cable (MultiAx)

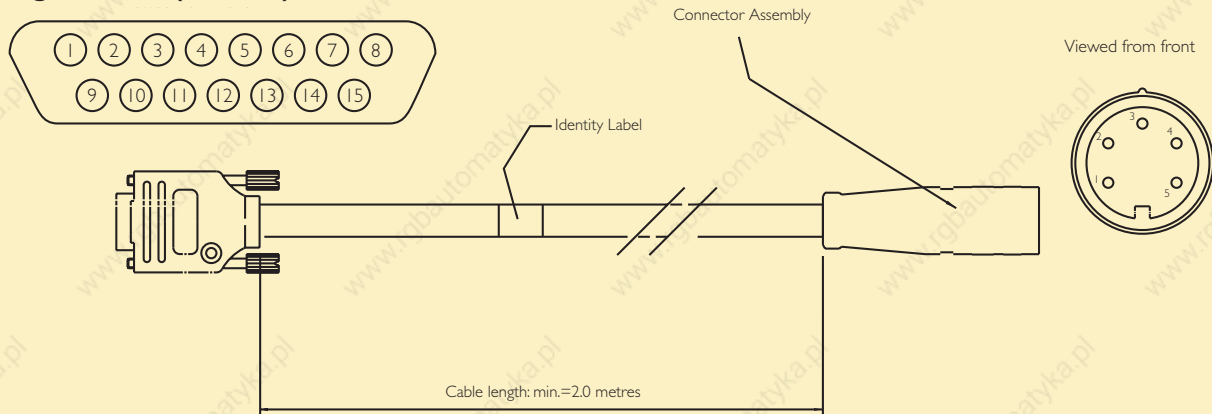

Connection details			PUR	PVC
'D' Type	Amphenol	Function	Colour	Colour
14	1	COMM	BROWN	ORANGE
13	5	COMM	WHITE	WHITE/ORANGE
9	3	+24V	YELLOW	WHITE/GREEN
10	2	0V	GREEN	GREEN
15	4 + BODY	SCREEN	SCREEN	SCREEN

LSMV - AC Motors

3-Phase TEFV induction motors for variable speed drive systems 0.75 to 132 kW

LSMV: A flexible design concept with a complete range of motors and options from which to build solutions to exactly match your application requirements:

- **Speed accuracy, safety of rotation:**
 - Incremental encoder
- **Position control:**
 - Absolute encoder
- **Positive safety:**
 - Brake
- **Operation outside guaranteed speed range:**
 - Forced ventilation
- **External finish:**
 - Standard, customised

Reduced maintenance

Limiting the temperature rise increases the total life and performance of the motor.

Powerful dynamics enhanced

by the availability of significant torque both at startup and at all speeds.

Interchangeability

The whole LSMV range conforms fully with IEC standards; the motor can therefore be exchanged with any other standard motor.

Reinforced mechanical resistance.

Use of metal terminal box(es) and fan cover.

LSMV: Guaranteed interchangeability

with standard motors through conformity with the IEC standard, whilst benefiting from electrical adaptation of the basic motor.

LSMV :A product born of experience,

designed to meet technical criteria defined by Leroy-Somer in the areas of thermal reserve, watertightness, mechanism of rotation, concentricity, noise level, modularity and standardisation. It also benefits from enhanced balancing, increased thermal reserve, improved efficiency and integrated thermal protection. All of these features have ISO 9001 certification.

Noise reduction for improved

ease of use, achieved by the addition of cast iron end shields at both drive end and non-drive end.

Higher balancing class :

- S, for frame size ≤ 132 – R, for frame size ≥ 160 .

Maximum operating safety

Protection via 3 PTC sensors installed in the motor winding.

Extended life due to the choice of balancing and the concentric design.

Energy savings

Innovative design of the magnetic circuits has improved mains operation, leading to increased efficiency at the rated speed.

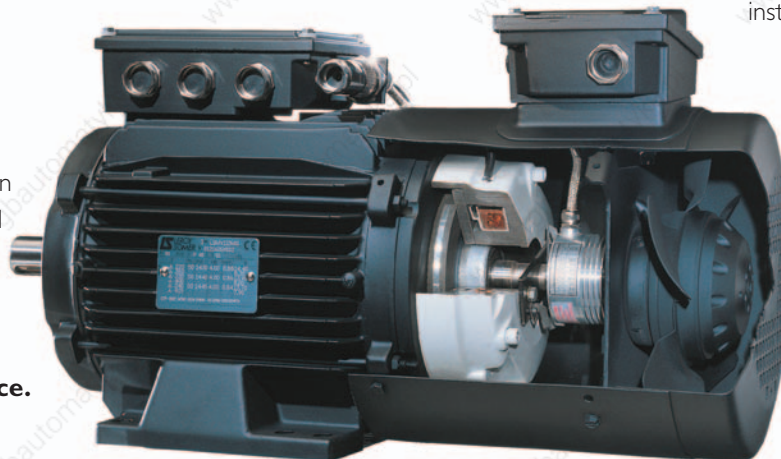

AC MOTORS: A SIMPLE AND CLEAR SELECTION GUIDE

Centrifugal or quadratic resistive torque applications

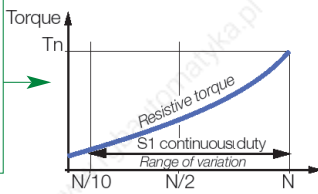

Operation with resistive torque depending on the speed for $f < 50$ Hz

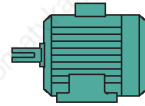

LS motor

General or constant resistive torque applications

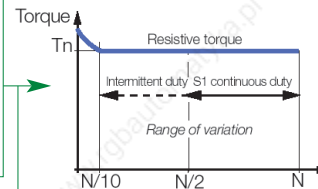

Operation over a speed range of 25 to 50 Hz (1 to 2) in continuous duty (S1)

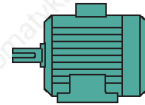

LS motor

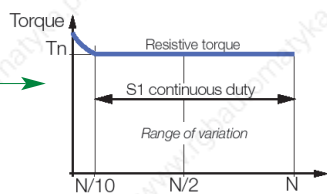

Operation over a speed range of 5 to 50 Hz (1 to 10) in continuous duty (S1)

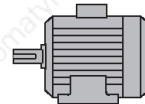

LSMV motor

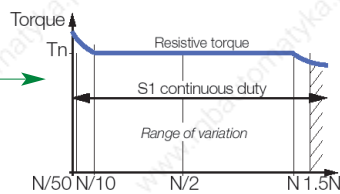

Operation over extreme speed ranges: < 5 Hz and > 70 Hz

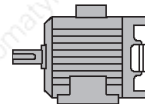

LSMV motor with forced ventilation

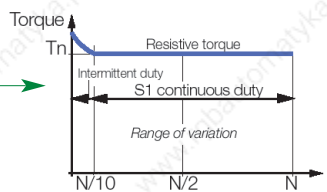

Operation:
- from 0 to 50 Hz with a range of 0 to 5 Hz in intermittent duty
- with good precision of both speed and torque dynamics

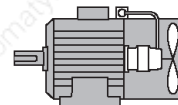

LSMV motor with encoder

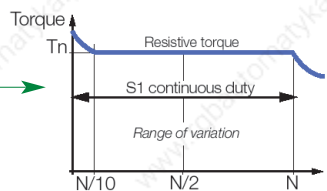

Operation:
- from 0 to 50 Hz with a range of 0 to 5 Hz in continuous duty
- with good precision of both speed and torque dynamics

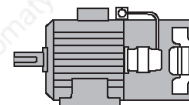

LSMV motor with encoder and forced ventilation

LSMV - AN ELECTRIC MOTOR RANGE WHICH OPERATES AT VARIABLE SPEED WITHOUT DERATING

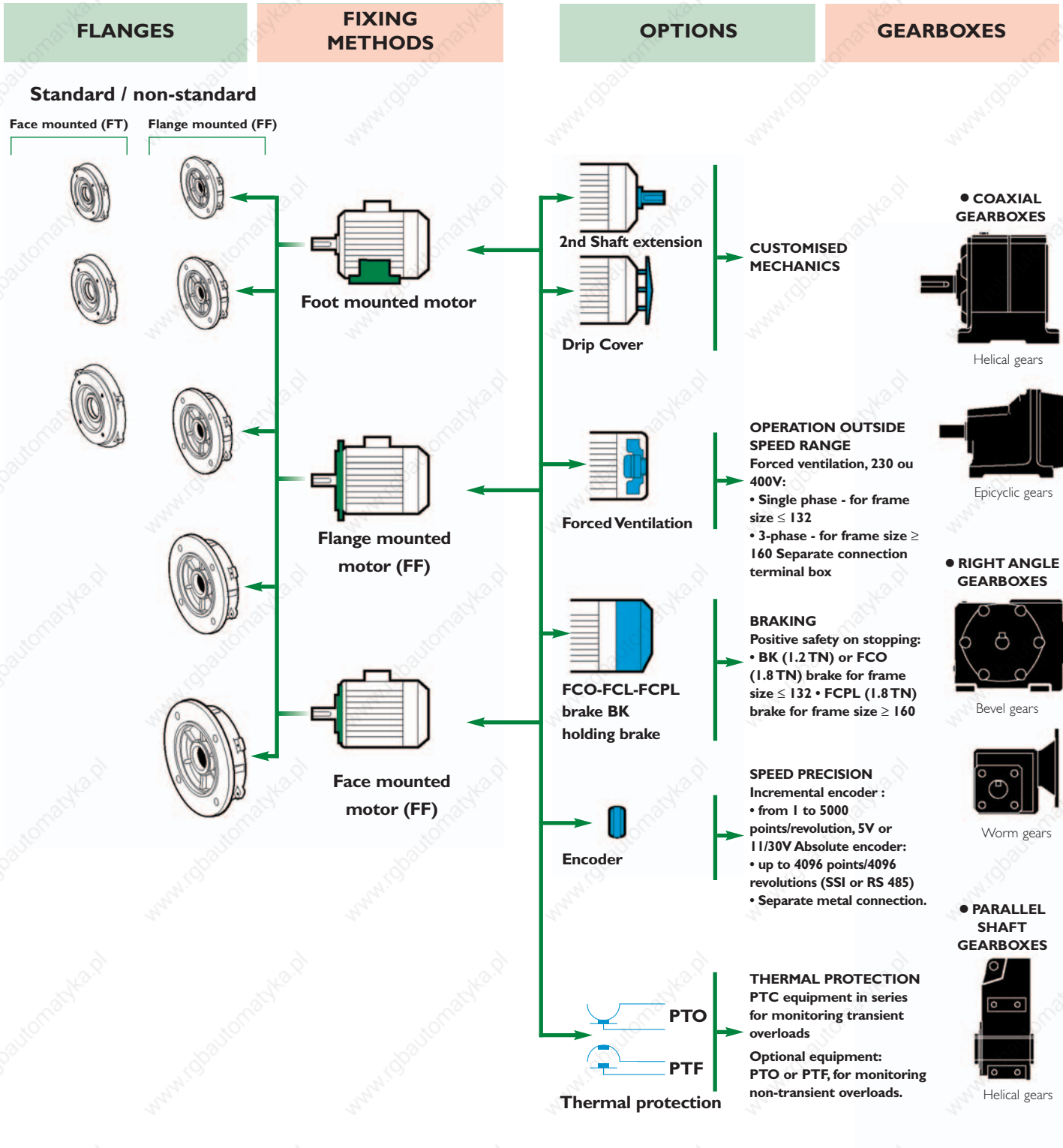

LSMV
AC Motors

0.75 TO 132 kW LSMV MOTOR



MAINS SUPPLY 400 V - 50 HZ
MOTOR CONNECTION : Y 400 V

MAIN DESIGN CHARACTERISTICS

Frame: **Aluminium alloy**
 Bearings: **Cast iron**
 Protection: **IP 55**
 Insulation: **Class F**
 Voltage: **400V ± 10%**
 For relative humidity up to **95%**
 Terminal boxes: **Aluminium**
 Fan cover: **Metal**
 Bearings: **C3 play, LHT lubrication, DE thrust type, locked in flange-mounted versions**
 Balancing:
 - **Class S:** Frame size 80 to 132
 - **Class R:** Frame size 160 to 315
 Sensors: **PTC** in the winding
 Paint: System **Ia**, black **RAL9005**

Type	Rated power at 50 Hz	Rated speed	Rated torque	Maximum torque/ rated torque	No-load current	Rated current	power factor	Efficiency	Moment of inertia	Weight
	P_N kW	N_N min ⁻¹	M_M M_N	$\frac{M_N}{M_N}$	I_0 A	I_N (400V) A	$\cos \varphi$	μ %	J kg·m ²	IM B3 kg
LS MV 80 L	0.75	1435	4.8	2.9	1.6	2	0.71	75	0.0024	10.8
LS MV 90 SL	1.1	1445	7.1	2.4	1.3	2.5	0.82	79	0.0039	15.3
LS MV 90 L	1.5	1435	9.7	1.9	1.5	3.2	0.84	80	0.0049	17.3
LS MV 100 L	2.2	1440	14	2.8	2.4	4.7	0.84	81	0.0051	22.7
LS MV 100 L	3	1430	19.5	2.4	2.9	6.3	0.84	82	0.0071	25.7
LS MV 112 MG	4	1440	26	2.7	3.8	8	0.86	84	0.015	33.3
LS MV 132 SM	5.5	1460	35	2.5	4.1	10.4	0.88	87	0.0334	56.3
LS MV 132 M	7.5	1455	49	2.3	4.7	14	0.89	87	0.035	62.3
LS MV 132 M	9	1460	60	2.6	6.5	16.8	0.88	88	0.0385	65
LS MV 160 MR	11	1460	72	2.5	6.6	20.2	0.88	89	0.069	87
LS MV 160 LU	15	1465	100	3.6	11	28.1	0.85	90.6	0.095	110
LS MV 180 MU	18.5	1465	120	2.6	11	32.9	0.89	91.2	0.147	165
LS MV 180 LU	22	1465	144	2.8	15.4	40.8	0.86	90.6	0.147	165
LS MV 200 L	30	1475	195	2.9	22.2	55.1	0.85	92.4	0.23	190
LS MV 225 SR	37	1475	235	2.8	24.6	66.8	0.86	93	0.28	235
LS MV 225 MK	45	1480	293	3	31.6	83	0.84	93.1	0.75	325
LS MV 250 MP	55	1480	356	3	45	104	0.82	92.7	0.79	355
LS MV 280 SP	75	1480	475	3.3	59.3	138	0.83	94.5	1.45	490
LS MV 280 MK	90	1490	577	3.1	64	164	0.84	94.3	2.54	690
LS MV 315 SP	110	1485	707	3.5	79.2	201	0.83	95	2.95	785
LS MV 315 MR	132	1485	845	3.1	89.5	232	0.86	96	3.37	855

ORDER CODE

For different no. of poles or voltage consult local Drive Centre

4P 1500 min ⁻¹	LSMV	180	MU	18.5kW	IM 1001 (IM B3)	400 V	50 Hz	IP 55
No of poles Speed(s)	Range identification	Frame size IEC 72	Frame type	Rated power	Mounting arrangements IEC 34-7	Supply voltage	Mains frequency	Degree of protection IEC 34-5

LSK D.C. Motor

Shaft and bearings with high overload capacity (for belts transmission). Roller bearings may be used in the drive end shield for very high radial loads. Marking on shaft extension indicating the balancing class.

Compact design with high power / weight ratio.

Removable lifting rings.

Machined registers for high precision geometry.

Large size multiposition terminal box.

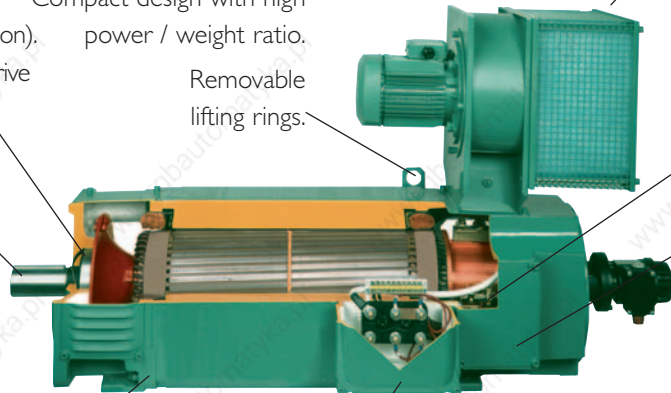

Forced ventilation:

- multiposition
- multivoltage - multifrequency
- ensures good thermal reserve
- sound screen in option

Large number of possible options.

Brush holders fitted in option with wear limit microswitches.

Cast iron brackets.

Easy brush access via 4 large inspection doors.

Transparent inspection doors in option.

PTC probes connected in series provide added protection against incorrect use.

LSK RANGE

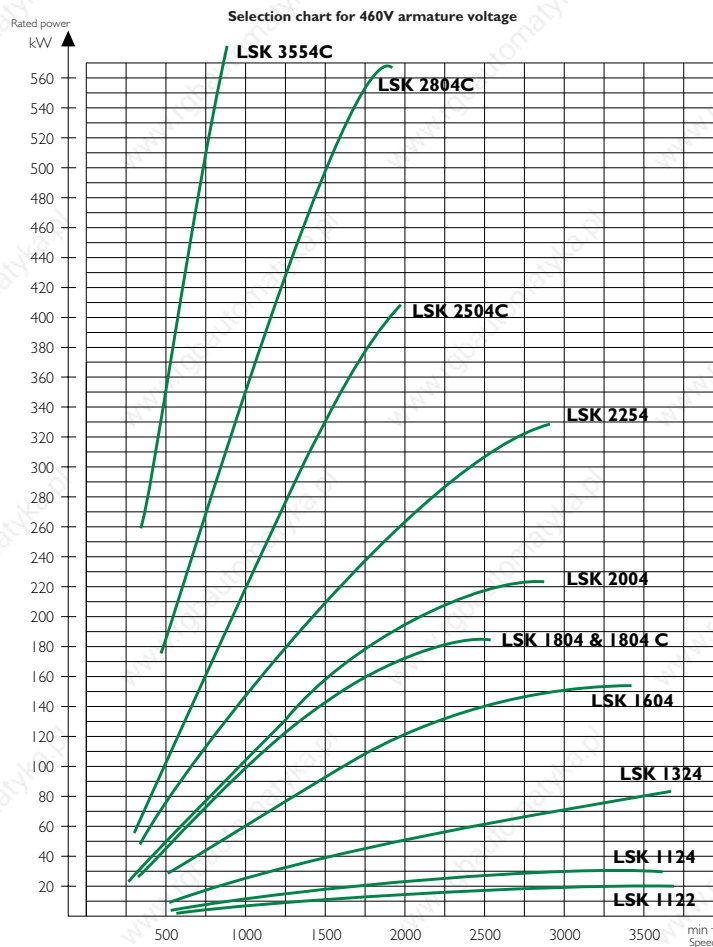

LSK motor capabilities (in accordance with standard IEC 34.1) are achieved with:

- Full bridge three-phase power supply
- IP 23 protection

- IC 06 cooling (forced ventilation)
- S1 continuous duty
- Ambient temperature ≤ 40°C
- Class H insulation system

DIMENSIONS

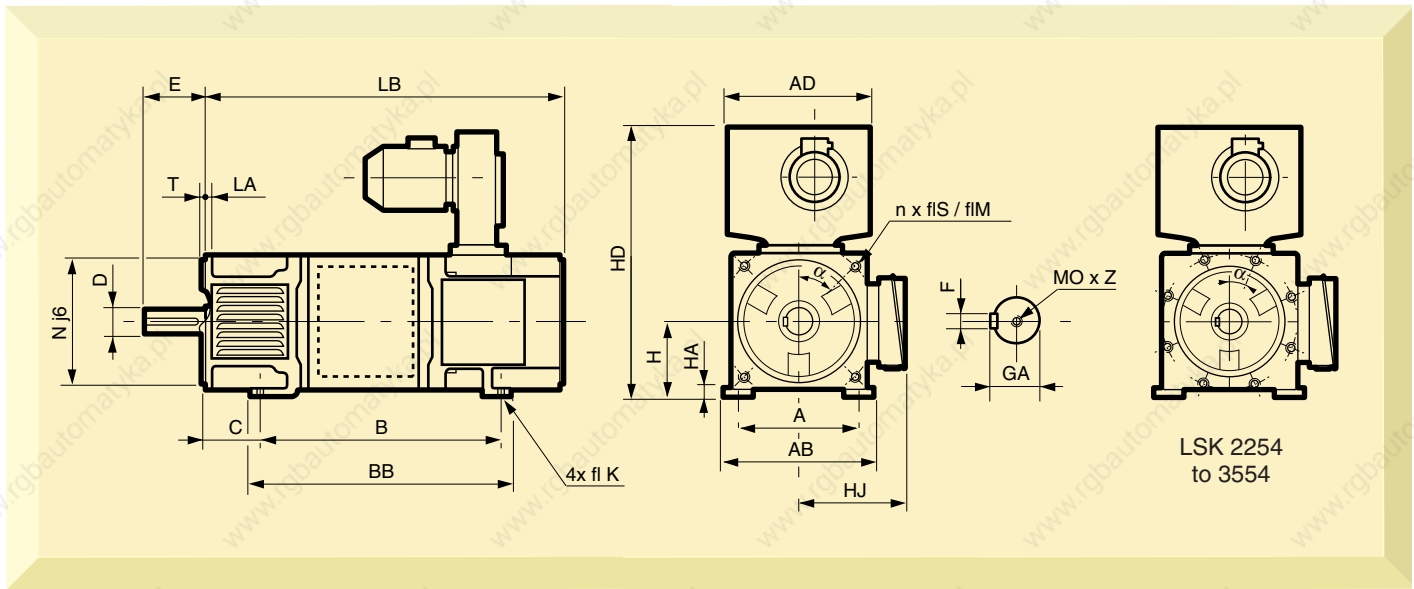

Motor type	Main dimensions												Shaft						Standard flange					
	A	AB	AD	B	BB	C	H	HA	HD	HJ	K	LB	D	E	F	GA	O	Z	LA	M	N	n°	S	T
LSK 1122 S	190	220	220	354	378	70	112	10	472	202	12	520	38 k6	80	10	41	12	28	20	265	230	4	14	4
LSK 1122 L	190	220	220	410	434	70	112	10	472	202	12	576	38 k6	80	10	41	12	28	20	265	230	4	14	4
LSK 1122 VL	190	220	220	470	494	70	112	10	472	202	12	636	38 k6	80	10	41	12	28	20	265	230	4	14	4
LSK 1124 M	190	220	220	380	404	70	112	10	472	202	12	546	38 k6	80	10	41	12	28	20	265	230	4	14	4
LSK 1124 L	190	220	220	450	474	70	112	10	472	202	12	616	38 k6	80	10	41	12	28	20	265	230	4	14	4
LSK 1124 VL	190	220	220	520	544	70	112	10	472	202	12	686	38 k6	80	10	41	12	28	20	265	230	4	14	4
LSK 1324 S	216	245	260	432	462	89	132	12	552	248	12	590	48 k6	110	14	51.5	16	36	22	300	250	4	18	5
LSK 1324 M	216	245	260	482	512	89	132	12	552	248	12	640	48 k6	110	14	51.5	16	36	22	300	250	4	18	5
LSK 1324 VL	216	245	260	582	612	89	132	12	552	248	12	740	48 k6	110	14	51.5	16	36	22	300	250	4	18	5
LSK 1324 XVL	216	245	260	652	682	89	132	12	552	248	12	810	48 k6	110	14	51.5	16	36	22	300	250	4	18	5
LSK 1604 S	254	300	318	425	469	103	160	15	678	313	14	750	55 m6	110	16	59	20	42	24	350	300	4	18	5
LSK 1604 M	254	300	318	505	549	103	160	15	678	313	14	830	55 m6	110	16	59	20	42	24	350	300	4	18	5
LSK 1604 L	254	300	318	565	609	103	160	15	678	313	14	890	55 m6	110	16	59	20	42	24	350	300	4	18	5
LSK 1604 VL	254	300	318	665	709	103	160	15	678	313	14	990	55 m6	110	16	59	20	42	24	350	300	4	18	5
LSK 1804 M	279	356	318	653	738	121	180	15	735	317	14	889	60 m6	140	18	64	20	42	20	350	300	4	18	5
LSK 1804 L	279	356	318	698	783	121	180	15	735	317	14	934	60 m6	140	18	64	20	42	20	350	300	4	18	5
LSK 1804 VL	279	356	356	883	968	121	180	15	760	317	14	1099	60 m6	140	18	64	20	42	20	350	300	4	18	5
LSK 1804C M	279	356	318	653	738	121	180	15	735	317	14	889	60 m6	140	18	64	20	42	20	350	300	4	18	5
LSK 1804C L	279	356	318	698	783	121	180	15	735	317	14	934	60 m6	140	18	64	20	42	20	350	300	4	18	5
LSK 2004 M	318	396	495	737	830	133	200	18	921	335	18	1000	65 m6	140	18	69	20	42	20	400	350	4	18	5
LSK 2004 L	318	396	495	802	895	133	200	18	921	335	18	1065	65 m6	140	18	69	20	42	20	400	350	4	18	5
LSK 2254 M	356	445	548	793.5	888	149	225	21	993	360	18	1090	80 m6	170	22	85	20	36	31	400	350	8	18	5
LSK 2254 L	356	445	548	863.5	958	149	225	21	993	360	18	1160	80 m6	170	22	85	20	36	31	400	350	8	18	5
LSK 2254 VL	356	445	548	913.5	1008	149	225	21	993	360	18	1210	80 m6	170	22	85	20	36	31	400	350	8	18	5
LSK 2504C M	406	494	600	1018	1216	168	250	22	1180	495	22	1360	100 m6	170	28	106	24	50	35	400	350	8	18	5
LSK 2504C L	406	494	600	1078	1276	168	250	22	1180	495	22	1420	100 m6	170	28	106	24	50	35	400	350	8	18	5
LSK 2804C SM	457	550	655	1106	1248	190	280	29	1300	530	22	1477	110 m6	170	28	116	24	50	46	500	450	8	26	6
LSK 2804C M	457	550	655	1106	1315	190	280	29	1300	530	22	1544	110 m6	170	28	116	24	50	46	500	450	8	26	6
LSK 2804C SL	457	550	655	1216	1358	190	280	29	1300	530	22	1587	110 m6	170	28	116	24	50	46	500	450	8	26	6
LSK 2804C L	457	550	655	1216	1425	190	280	29	1300	530	22	1654	110 m6	170	28	116	24	50	46	500	450	8	26	6
LSK 3554C VS	610	700	705	700	1536	254	355	22.5	1521	680	27	1580	125 m6	210	32	132	24	50	28	940	880	8	25	6
LSK 3554C S	610	700	705	800	1636	254	355	22.5	1521	680	27	1680	125 m6	210	32	132	24	50	28	940	880	8	25	6
LSK 3554C M	610	700	705	850	1686	254	355	22.5	1521	680	27	1730	125 m6	210	32	132	24	50	28	940	880	8	25	6
LSK 3554C L	610	700	705	950	1786	254	355	22.5	1521	680	27	1830	125 m6	210	32	132	24	50	28	940	880	8	25	6
LSK 3554C VL	610	700	705	1100	1936	254	355	22.5	1521	680	27	1980	125 m6	210	32	132	24	50	28	940	880	8	25	6

ADAPTATIONS

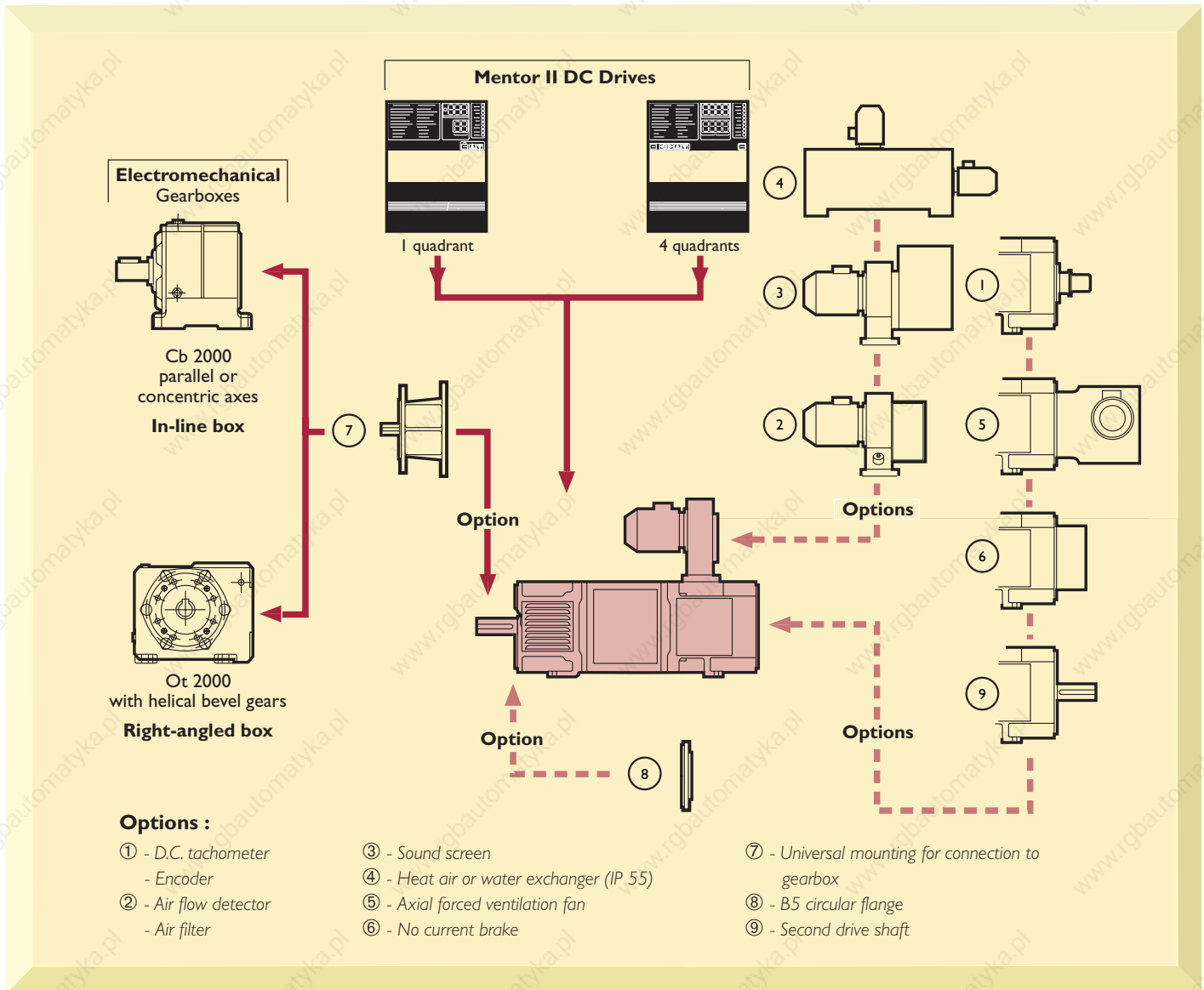

LSK motor applications:

- Processing of rubber and plastics
- Wire drawing, cable making
- Iron and steel industry, metallurgy, presses
- Paper and card manufacture, printing
- Container cranes
- Mechanical hoist
- Variable flow pump and fan
- Sugar industry



Linear Permanent Magnet Motors

OVERVIEW

Linear motors have been around as long as any other kind of electric motor, and have had their supporters and detractors over the years for a wide range of linear applications, from rams and material movement to luggage handling and funfair rides.

Historically, linear motors have been very successful in the semi-conductor manufacturing industry and now their suppliers are making forays into many other markets, with increasing success. The main barrier to their growth has been initial cost, which is generally higher than the traditional servomotors.

Unidrive has been applied successfully with a wide range of linear motor types, from a diverse range of suppliers. Contact your local Drive Centre for help in applying Unidrive with linear motors.



APPLICATIONS

In application areas, which have undergone strong growth, linear motors are increasingly being seen as possible replacements for traditional linear solutions, a typical example being mechanical cams, which give a pre-determined linear stroke.

Typical applications include:

- Semiconductor processing
- Materials handling
- Packaging machines
- Glass processing
- Laser Cutting
- PCB drilling
- Pick and Place
- Transfer machines
- Flying Shears
- Transport systems
- Extrusion pullers
- Robotic

... and many more.

COMPARISON OF LINEAR AND ROTARY MOTORS

Brushless Permanent Magnet Motor

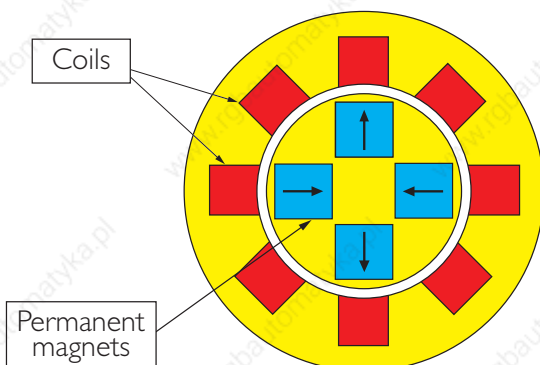

Cut and roll open...

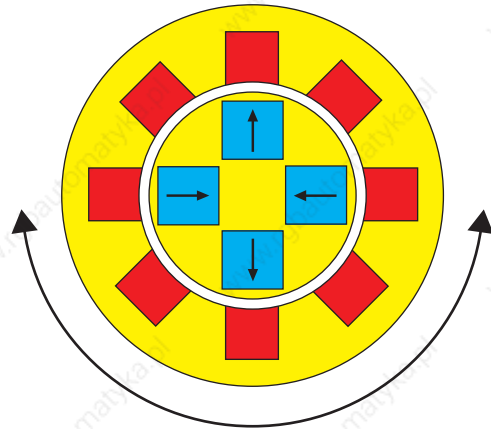

Permanent Magnet Linear Motor

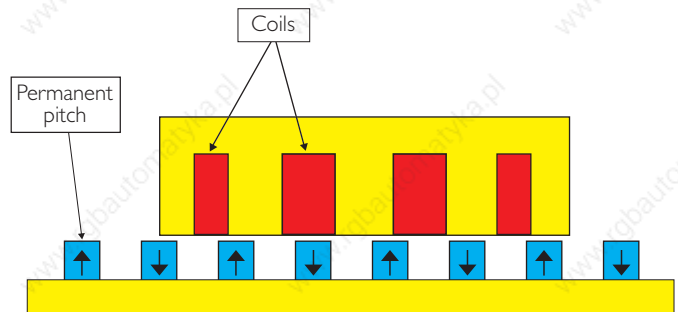

A rotary motor opened up and laid out flat

The same electromagnetic force that produces torque in a rotary motor also produces direct force in a linear motor. A permanent magnet linear motor is similar to a permanent magnet rotary motor. Take a rotary motor, split it radially along its axis of rotation and flatten it out. The result is a flat linear motor that produces direct linear force instead of torque. Why? Torque is force at a radial distance measured in Newton metres. Removing the distance (axis of rotation) leaves direct linear force measured in Newtons. It follows that linear motors utilise the same controls as rotary motors. And similar to a rotary motor with rotary encoders, linear motor positioning is provided by a linear encoder.

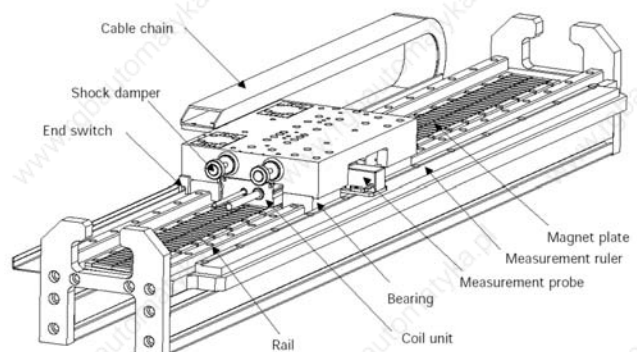

LINEAR MOTORS SUITABLE FOR UNIDRIVE

There are three main types of permanent magnet linear motors:

- Flat - iron core
- U-shaped, ironless core
- Tubular

Iron Core Synchronous Linear Motor

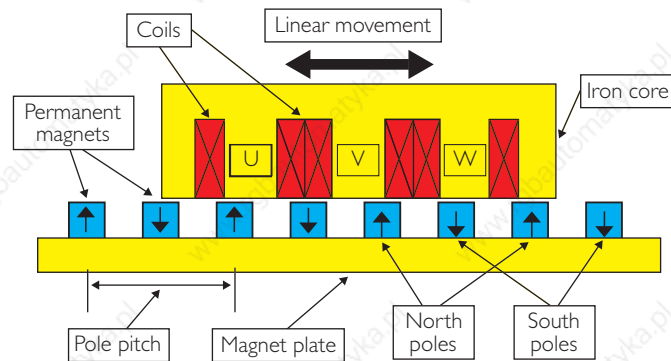

This type of motor has a low magnetic resistance path. The flux path has the iron core and the magnet plate as excellent flux conductors and the resistance in the circuit are the magnets and a single air gap. Due to this low resistance, this motor shows a strong flux yielding high forces and has very good efficiency.

The benefits of this type of motor are:

- High peak force density
- High continuous force density
- Relatively low heat dissipation

This motor type exhibits an attraction force of roughly two to three times the maximum thrust force. This attraction force has to be carried by load bearings, which have to maintain a constant air gap between coil unit and magnet plate.

A second effect of the iron core is cogging. The iron core will always have preferred positions on the magnet plate, with respect to the magnets, because the iron in the slide is attracted to the magnets. Careful design of the coil unit can reduce the cogging effect. Cogging is generally not a problem for most applications because it is compensated by the velocity loop on the drive.

Because of the high flux, the motor (coil unit) is highly inductive. This is useful for smoothing the current that the servo drive sees but requires a high voltage on the drive output to compensate for the long time constant of the coils for very sudden force changes.

Linear speeds in excess of 10 m/s can be achieved with this type of motor.

Ironless Core Synchronous Linear Motor

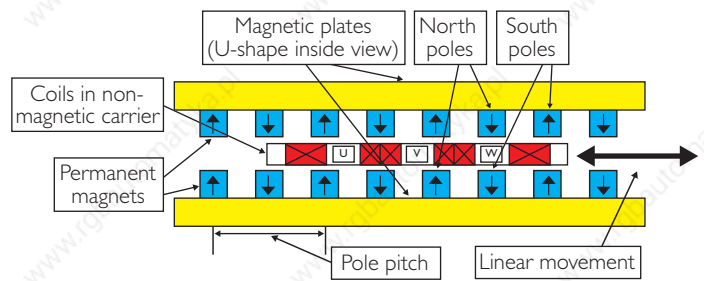

In this type, the distance between the two opposing magnets – two air gaps plus the coil thickness – forms the resistance of the magnet flux path. This is a high resistance causing a low magnetic flux.

Therefore this type of motor is characterised by:

- Moderate peak force density
- Low continuous force density
- More heat dissipation compared to the iron core

Because the coil section contains no magnetic material, the slide has no attraction force so there is no cogging when the slide is pushed down the magnet plate while the motor is de-energised. The only force generated is the thrust force.

Since the linear motor has a high magnetic resistance, the coil inductance is relatively low allowing high rates of change in current for quick movements and very quick responses to external forces. Because of this ability, the motor requires a responsive controller and servo drive for obtaining accurate control.

These characteristics mean that this motor is very dynamic and achieves very short settling times and high speeds.

A disadvantage of this type is that it requires a double row of magnets making the magnet yokes rather expensive compared to the iron core types.

Linear speeds in excess of 15 m/s can be achieved with this type of motor.

Tubular Linear Motor

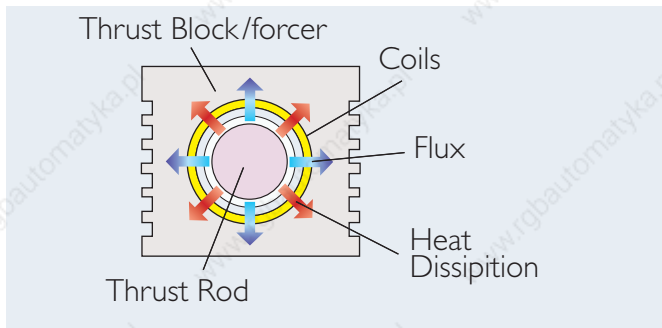

The tubular linear motor makes optimal use of the magnetic flux. All of the coils cut all of the flux at right angles to produce a pure linear thrust. A large air gap is possible and the symmetrical design is unaffected by misalignment.

The tubular linear motor has good thermal efficiency, radiating heat uniformly and has high duty cycle capability without the need for additional cooling. One point of interest is that iron-core motors of similar peak force rating have higher continuous force ratings.

This simple arrangement comprises a tubular thrust rod and a moving forcer carrying circular coils. It is simple and easy to use. Unlike iron-cored linear motor types, there are:

- No precision air gaps.
- No precision alignment.
- No attractive forces.

Their benefits are:

- Low motor time constant
- Ripple free force
- Smooth, virtually perfect linear thrust/current response along length of travel
- High duty cycle capability
- Industrially rugged product due to simple sealed design of armature and stator

Linear speeds in excess of 20 m/s and acceleration rates over 1100 m/s² can be achieved with this type of motor:

UNIDRIVE CONFIGURATION PARAMETERS

Motor Power Connections

The coil unit power connections consist of the UVW windings and the safety Earth. The coils tend to be wound for either 400 Vrms (560VDC bus) or 220 Vrms (300VDC bus), both are three phase.

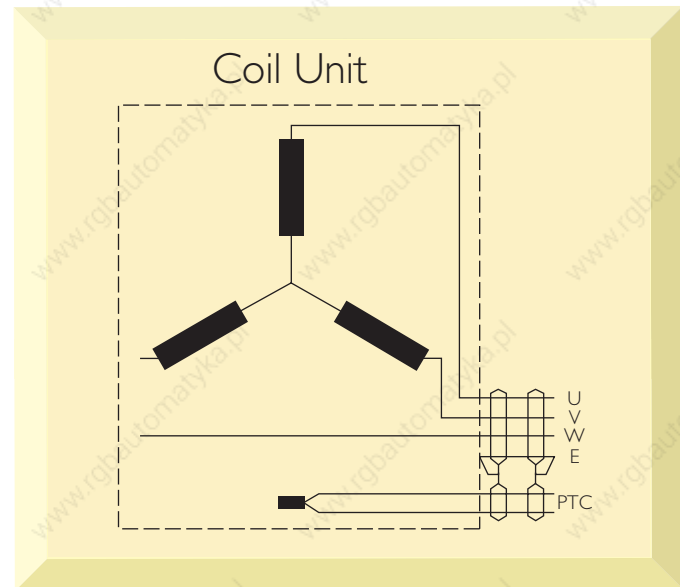

Feedback Types And Limitations

Most linear motor manufacturers tend to fit either linear quadrature incremental encoders or linear SinCos incremental encoders, with or without commutation signals. Other common types of linear encoders are absolute. These encoders tend to be EnDat, Hiperface or SSI. One benefit over incremental is that the servo drive does not need to perform an auto tune on power up but there is a drawback as absolute encoders cost more.

One of the characteristics of linear motors is their ability to operate with a high level of dynamic performance. Current technologies allow motors to run at over 20 m/s and have acceleration rates in excess of 1000 m/s². Careful consideration is required when selecting the type of feedback device to be used. Currently, Unidrive  has an input frequency limitation of 500kHz for quadrature pulses input and 500 kHz for SinCos cycles input with reduced interpolation resolution. It is common for linear encoder scales to have 20-micron or 40-micron graduations. If we apply the drive input frequency limitation to the 20-micron scale, we would get a maximum speed of 8.2 m/s, this figure doubles to 16.4 m/s if the 40-micron scale is used.

Autotune

Generally, linear motors are mounted in a horizontal position where gravity has no or little effect so running phase offset tests are no problem. Where linear motors are mounted vertically or where gravity has a large effect on the coil unit then problems can arise while running phase offset tests, this is because Unidrive  can not control the movement of the coil unit until correct alignment of motor flux is achieved. If excessive movement is detected during the flux alignment routine the drive will fail to complete the routine and trip.

Let us consider a linear motor that is on an incline, if the coil unit is suspended in mid-stroke and only held in place by cogging torque or friction. It is possible that executing a flux alignment test could kick-start the coil unit down the incline in an uncontrolled manner. To prevent this from happening you must either use an absolute encoder or an incremental encoder with commutation signals and consider having a brake fitted to the coil unit.

Incremental Encoders – No Commutation Signals

Standard Phasing Test

The standard phasing test moves the motor by 2 electrical cycles, which would equate to a displacement of 2 motor pole pitches. Direction of auto tune would depend on the setting of the “auto tune direction bit”. This mode of auto tuning would be used when the feedback encoder provides no commutation information and motor movement is not an issue. Would need to be executed every time the drive is powered up. The standard phasing test is executed by setting parameter #05.12=3.

“Minimum Movement” Phasing Test

The “Minimum Movement” phasing test energises the motor windings to force movement in the coil unit over the magnet plate. The drive detects the direction of the coil unit movement then re-aligns the field orientation in the motor windings until the coil unit movement changes direction. When the direction changes, the drive re-aligns the field orientation in the motor windings until the coil unit reverses direction again. This process is repeated until the encoder feedback is in phase with the field orientation in the motor windings. At this point the motor is correctly commutated, it also knows the number of pulses/lines per pole pitch of the motor. The whole phasing test is done with a maximum $\pm 5^\circ$ degrees of movement in an electrical cycle.

This mode of auto tuning would be used when the feedback encoder provides no commutation information and where it is a critical requirement that there is no or minimum motor movement. Would need to be executed every time the drive is powered up. The minimal movement phase test is configurable with three options available:

1. #05.12=5 – Runs phase routine only once.
2. #05.14=Ph.EnL – Runs phase routine on every “ENABLE”
3. #05.14=Ph.InL – Runs phase routine on first “ENABLE”

Absolute encoder

Auto tuning with absolute encoders need only to be performed once at the commissioning stage of the linear motor. Any of the auto tune routines discussed in the incremental encoder section could be used. Once the auto tune routine is complete the phase-offset angle is stored in the drive's encoder offset parameter. No subsequent auto tune is needed when the drive is powered up.

Unidrive  communicates to the encoder to find out the absolute position of the linear motor coil unit and the stored encoder offset value. Knowing this information the drive can determine the correct field orientation to applied to the coil unit windings.

**For further information on linear motors
please contact your nearest Control Techniques
Drive Centre.**

Drive, Servo, and Application Training at Control Techniques

At Control Techniques you will find a group of engineers dedicated to passing on all the information needed for you and your staff to get the most out of variable speed drives, servos or more complex motion control components.

Training your engineers

- Control Techniques has built its reputation designing world class drives and solutions for all industrial applications. From simple stand alone drives to the most complex control solution we can make certain that you have all the knowledge available to make the correct decisions for your own application
- We recognise that engineers may be at different levels of familiarity with modern drive technology and are always happy to tailor training courses to best suit the delegates. From practical hands-on to classroom theory we will ensure that you finish your course with the knowledge – the take away notes and worked examples – to become drive experts of the future
- Time is always a constraint and we recognise this by offering shift pattern flexibility to ensure that you can get the maximum training value from any particular course – just contact our trainers today to discuss what suits you best
- The St Giles facility in Newtown, UK offers the best possible mix of classroom learning with work benches in the same room enabling delegates to break off from theory to practical hands on and back to the classroom in a seamless learning cycle. Any questions can be quickly answered and backed up with visible worked solutions

If you feel you need a particular course tailoring to your specific application or circumstances then call us here or at your nearest Drive Centre to discuss the training solution you need.

Qualified training on the best control solution components ensures your engineers know how to get the most out of your equipment.



Global Training HQ in Newtown, UK

- Local training in local language
- Product experts who can mix classroom learning with practical hands on examples
- Calm focussed learning environment
- Shift pattern adopted to suit
- On site or at our own premises – you decide

- Training done at all levels from apprentice engineer to experienced motion control experts
- Bespoke training courses to suit you – following consultation
- Comprehensive course documentation and worked examples

Course Schedule at St Giles, Newtown, UK

Course Title	Duration (Days)	Frequency	Brief Description
Unidrive 	3	Monthly	Solutions Platform AC drive
Unidrive	3	Monthly	Solutions Platform AC drive
MD29. UD70, SM-Applications ()	3	Monthly	Software & Application programming
CTNet Highspeed communications	1	Every other month	High speed communications
Commander SK	1	Monthly	Simple & Easy AC drive
Commander SE	1	Monthly	Simple & Easy AC drive
Commander SX	1	Monthly	Simple and Easy AC drive (IP66)
Commander GP	1	Every other month	Simple and Easy AC drive
Introduction to Servos	1	Every other month	First steps in servo applications
Servo Drives and Systems	3	Monthly	Advanced application & sizing of servos
MC Motion Controller & Max Servo Drive & MultiAx	3	Monthly	High Precision Motion control
E-Series Drive	3	Quarterly	Easy to program AC servos
Mentor II	2	Monthly	Solutions Platform DC drive
Motion Control with CT Drives	3	Every other month	High Precision Motion control
Winder application solution software	2	Every other month	Standard winder solutions for Solutions Platform drives
Flying Shear application solution software	1	Every other month	Standard Flying Shear Solutions for Solutions Platform drives
Fan & Pump duty assist application solution software	1	Every other month	Standard Fan & Pump Duty Assist Solutions for Solutions Platform drives
AC Drives Maintenance	1	Quarterly	AC Drive Maintenance
DC Drives Maintenance	1	Quarterly	DC Drive Maintenance

Symbols and Formulae

- SI UNITS AND SYMBOLS

SI Base Units

Quantity	Unit Symbol	Unit Name
Length	m	metre
Mass	kg	kilogram
Time	s	second
Electric current	A	Ampere
Temperature	K	Kelvin
Luminous intensity	cd	candela

Decimal Multiples and Sub-multiples

Factor	Prefix	Symbol
10^{12}	tera	T
10^9	giga	G
10^6	mega	M
10^3	kilo	k
10^2	hecto	h
10	deca	da
10^{-1}	deci	d
10^{-2}	centi	c
10^{-3}	milli	m
10^{-6}	micro	μ
10^{-9}	nano	n
10^{-12}	pico	p
10^{-15}	femto	f
10^{-18}	atto	a

DERIVED UNITS

Geometrical

Symbol	Quantity	Symbol	Unit Name
l,s	length, distance	m	metre
A	area	m ²	square metre
V	volume	m ³	cubic metre
α, β, γ etc	plane angle	rad	radian
		°	degree
α, β, γ etc	solid angle		steradian

Time-related

Symbol	Quantity	Unit Symbol	Unit name
t	time	s	second
τ	time constant	s	second
u,v	velocity	ms ⁻¹	metre per second
a	acceleration	ms ⁻²	metre per second per second
ω	angular velocity	rad s ⁻¹	radian per second
α	angular acceleration	rad s ⁻²	radian per second per second
f	frequency	Hz	Hertz
n	rotational frequency	s ⁻¹	(revolution) per second

Mechanical

Symbol	Quantity	Unit Symbol	Unit name
m	mass	kg	kilogram
F	force	N	Newton
G (W)	weight	N	Newton
J	moment of inertia	kgm ²	kilogram metre squared
M (T)	torque	kgm	kilogram metre
W (E)	work (energy)	J	Joule
P	power	W	Watt
p	pressure	Pa	Pascal
E	modulus of elasticity	Pa	Pascal
σ	stress	Pa	Pascal
ρ	density	kgm ⁻³	kilogram per cubic metre
δx	rate of flow	m ³ s ⁻¹	metre per cubic second
k, k ₁ , etc	any constant factor		

- PROTECTIVE ENCLOSURES - IP AND NEMA

Protective Enclosures - Non-hazardous Areas

IP Protection

IP Protection is a European system of classification which is widely accepted internationally, and indicates the degree of protection against the ingress of solid objects, dust, liquids and personal contact.

The first numeral indicates the degree of protection against the ingress of solid objects (including parts of the body) and dust. The second numeral indicates the degree of protection against the ingress of water.

IP Enclosure - First Numeral

1st Numeral	Degree of Protection	
	Short Description	Definition
0	Non-protected	No special protection
1	Protected against solid objects greater than 50mm	A large surface of the body, such as a hand (but no protection against deliberate access). Solid objects exceeding 50mm in diameter.
2	Protected against solid objects greater than 12mm	Fingers or similar objects not exceeding 80mm in length. Solid objects exceeding 12mm in diameter.
3	Protected against solid objects greater than 2.5mm	Tools, wires, etc. of diameter or thickness greater than 2.5mm. Solid objects exceeding 2.5mm in diameter.
4	Protected against solid objects greater than 1.0mm	Wires, or strips of thickness greater than 1.0mm. Solid objects exceeding 1.0mm in diameter.
5	Dust-protected	Ingress of dust is not totally prevented but does not enter in sufficient quantity to interfere with satisfactory operation of the equipment.
6	Dust-tight	No ingress of dust.

IP Enclosure - Second Numeral

2nd Numeral	Degree of Protection	
	Short Description	Definition
0	Non-protected	No special protection
1	Protected against dripping water	Dripping water (vertically falling drops) shall have no harmful effect.
2	Protected against dripping water when tilted up to 15°	Vertically dripping water shall have no harmful effect when the enclosure is tilted at any angle up to 15° from its normal position.
3	Protected against spraying water	Water falling as a spray at an angle up to 60° from the vertical shall have no harmful effect.
4	Protected against splashing water	Water sprayed against the enclosure from any direction shall have no harmful effect.
5	Protected against water jets	Water projected by a nozzle against the enclosure from any direction shall have no harmful effect.
6	Projected against heavy seas	Water from heavy seas or water projected in powerful jets shall not enter the enclosure in harmful quantities.
7	Protected against the effects of immersion	Ingress of water in a harmful quantity shall not be possible when the enclosure is immersed in water under defined conditions of pressure and time.

NEMA and UL Standards

The North American Electrical Manufacturers Association (NEMA) and Underwriters Laboratories Inc. (UL) enclosure standards designate by means of a type number the environmental conditions for which an enclosure is suitable. A particular enclosure may have more than one type number. The table below summarises the type designations of NEMA 250; the designators specified by UL50 and UL508 are substantially the same, with differences of detail only in the description; for further information, reference should be made to the standard specification.

NEMA Standards 250 I.109. 1979

Type Designation	Intended Use and Description
1	Enclosure intended for indoor use primarily to provide a degree of protection against contact with the enclosed equipment.
2	Enclosure intended for indoor use primarily to provide a degree of protection against limited amounts of falling water and dirt.
3	Enclosure intended for outdoor use primarily to provide a degree of protection against windblown dust, rain, sleet and external ice formation.
3R	Enclosure intended for outdoor use primarily to provide a degree of protection against falling rain, sleet and external ice formation.
4	Enclosure intended for indoor or outdoor use primarily to provide a degree of protection against windblown dust and rain, splashing water and hose-directed water.
4X	Enclosure intended for indoor or outdoor use primarily to provide a degree of protection against corrosion, windblown dust and rain, splashing water and hose-directed water.
12	Enclosure intended for indoor use primarily to provide a degree of protection against dust, falling dirt and dripping non-corrosive liquid.
13	Enclosure intended for outdoor use primarily to provide a degree of protection against dust, spraying water, oil and non-corrosive liquid.

Conversion of NEMA Type Numbers to IEC Classification Designations

Not to be used to convert IEC Classifications Designations to NEMA Numbers

NEMA Enclosure Type Number	IEC Enclosure Classification Designation
1	IP10
2	IP11
3	IP54
3R	IP14
3S	IP54
4 and 4X	IP56
5	IP52
6 and 6P	IP67
12 and 12K	IP52
13	IP54

Note: This comparison is based on tests specified in IEC Publication 529: 1976.

ELECTRICAL FORMULAE

Electrical Quantities

Quantity	Symbol	Unit Symbol	Unit name
Electromotive force	E, e*	Volt	V
Potential difference	V, v*	Volt	V
Current	I, i*	Ampere	A
Magnetic flux	Φ	Weber	Weber
Frequency	f	Hertz	Hz
Flux linkage	λ	Weber-turns	-
Resistance	R	Ohm	Ω
Inductance	L	Henry	H
Capacitance	C	Farad	F
Impedance	Z	Ohm	Ω
Reactance	X	Ohm	Ω
Power, dc, or active	P	Watt	Ω
Power, reactive	Q	Volt-ampere reactive	VA _r , var
Power, total or apparent	S	Volt-ampere	VA
Power factor angle	φ	-	°, deg.
Angular velocity	ω	Radians per second	rad s ⁻¹
Rotational velocity	n	Revolutions per second	s ⁻¹ , rev s ⁻¹
		Revolutions per minute	min ⁻¹ , rpm
Efficiency	η	-	
Number of pairs of poles	p	-	

* Capital and small letters designate rms and instantaneous value respectively.

AC 3-Phase

(Assuming Balanced Symmetrical Waveform)

All quantities rms values:

V_l = Line-to-line voltage

V_p = Phase voltage (line-to-neutral)

I_l = line current (star)

I_p = Phase current (delta)

In a STAR connected circuit, $V_p = V_l / \sqrt{3}$, $V_l = \sqrt{3} V_p$, $I_l = I_p$

In a DELTA connected circuit: $I_p = I_l / \sqrt{3}$, $I_l = \sqrt{3} I_p$, $V_l = V_p$

Total of apparent power in VA = $\sqrt{3} V_l I_l$

Active power in watts, W = $\sqrt{3} V_l I_l \cos \varphi$

Reactive power in VAR = $\sqrt{3} V_l I_l \sin \varphi$

Power factor (pf) = $\cos \varphi$

= Active power / Apparent power

= W / VA_r

AC Single-Phase

All quantities rms values:

$$V = I Z$$

Total or apparent power in VA = $V_l = I^2 Z = V^2 / Z$

Active power in watts, W = $V_l \cos \varphi$

Reactive power in VAR = $V_l \sin \varphi$

Three-Phase Induction Motors

All quantities rms values:

kW_{mech} = horsepower × 0.746

kW_{elec} = $\sqrt{3} V_l I_l \cos \varphi$ at rated speed and load

where V_l = supply voltage I_l = rated full load current

$\cos \varphi$ = rated full load power factor

Efficiency, $\eta = (\text{kW}_{\text{mech}} / \text{kW}_{\text{elec}}) \times 100$ per cent

Phase current $I_p = I_l$ for star connection

$I_p = I_l / \sqrt{3}$ for delta connection

Loads (phase values)

Resistance R, measured in Ohms (no energy storage)

Inductive reactance, $X_L = \omega L = 2\pi f L$ Ohms (stores energy)

Where f = frequency (Hz), L = Inductance (H)

Capacitive reactance, $X_C = 1/(\omega C) = 1/(2\pi f C)$

Where f = frequency (Hz), C = Capacitance (F)

Impedance

Impedance is the algebraic sum of the separate load values thus:

$$Z = \sqrt{(R^2 + X_L^2)} \text{ or } \sqrt{(R^2 + X_C^2)}$$

If R, X_L and X_C are present in series in the same circuit then X_L and X_C may be summated, treating X_C as negative, thus

$$Z = \sqrt{(R^2 + (X_L - X_C)^2)}$$

MECHANICAL FORMULAE

Term	Description	Unit
d	Diameter	m
F	Force	N
g	Acceleration due to gravity	ms^{-2}
J	Total inertia	kgm^2
J_L	Load inertia	kgm^2
J_M	Motor inertia	kgm^2
m	Mass	kg
M	Motor torque	Nm
M_a	Accelerating torque	Nm
M_L	Load torque	Nm
n	Rotational frequency	rpm^*
n_1	- input	rpm^*
n_2	- output	rpm^*
Δn	Change of rotational frequency	rpm^*
p	Pitch	m
P	Motor power	kW
P_a	Accelerating power	kW
P_L	Load power absorbed	kW
r	Radius	m
s	Distance	m
t	Acceleration time	s
Δt	Acceleration period	s
v	Linear velocity	m/min^*
Δv	Change of linear velocity	m/min^*
V	Traction capacity	M^2s^{-1}
W	Energy	J (Joule)
η	Efficiency	-
μ	Coefficient of friction	-

Note

For practical convenience, some of the units in the formulae following are not SI units; for example, rotational frequency is commonly measured in revolutions per minute, although the SI unit is revolutions per second. In these Servo Formulae, the terms used are as tabulated above. Those which are in non-SI units are marked *.

Linear Motion

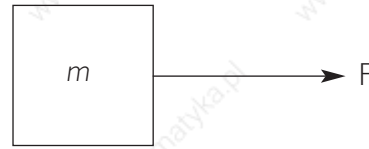

Fig A

Consider a body mass m acted upon by a single force F , Fig A. The body accelerates in the direction in which the force is acting, at a rate given by:

$$A = F/m$$

After a time t has elapsed, the body has achieved a velocity v , where:

$$v = u + at$$

(u is the initial velocity, before the force F was applied. If the body was initially at rest, u is zero)

The distance, s , travelled by the body during time t is

$$s = ut + at^2/2$$

Distance and velocity are related by the following equation, derived from the two previous ones:

$$v^2 - u^2 = 2as$$

The work done by the force in accelerating the body is the product of force and distance:

$$W = Fs$$

The kinetic energy of the body, ie the energy which it possesses by virtue of its motion, is the product of its mass and the square of its velocity:

$$E_k = mv^2/2$$

Furthermore, since energy is conserved, the work done by the force is equal to the change in the body's kinetic energy (neglecting losses):

$$W = m(v^2 - u^2)/2$$

Power is the rate at which work is done, therefore it is the product of force and velocity:

$$P = Fv$$

Rotational or Angular Motion

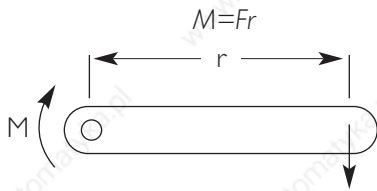

Fig A.11
The concept
of torque

A force acting perpendicular to a pivoted lever; Fig A.11, causes a turning effect or torque at the fulcrum. The torque is the product of the force and the radius at which it is applied.

$$M = Fr$$

A force acting perpendicular to a pivoted lever; Fig A.11, causes a turning effect or torque at the fulcrum. The torque is the product of the force and the radius at which it is applied.

$$M = Fr$$

If a torque is applied to a body which is free to rotate, as in Fig A.12, an acceleration results in a way which is analogous to the example of linear motion above. Indeed a similarity will be noticed between the equations of motion.

Any body which is capable of rotating possesses a property known as Moment of Inertia which tends to resist acceleration in the same way as does the mass of a body in linear motion. The moment of inertia is related not only to the mass of the body, but also to the distribution of that mass with respect to radius.

The moment of inertia of a solid cylinder of radius r is given by:

$$J = mr^2/2$$

By comparison, the moment of inertia of a hollow cylinder, of inner and outer radii respectively, is as follows:

$$J = m(r_o^2 - r_i^2)/2$$

It can be seen that, for a given outer radius, the moment of inertia of a hollow cylinder is greater than that of a solid cylinder of the same mass. In Fig A.12, a body having a moment of inertia J is acted upon by a torque M . Its angular acceleration is:

$$\alpha = M/J$$

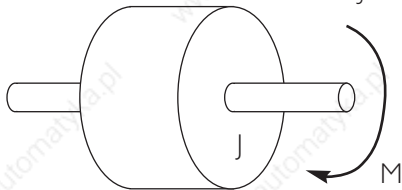

Fig A.12
The Action of
torque on a body

After a time t has elapsed, the angular velocity, ω (rate of change of angle) is given by:

$$\omega = \omega_o + \alpha t$$

(ω_o is the initial angular velocity, before the torque M was applied. If the body was initially at rest, ω_o is zero)

The angle, γ , through which the body rotates in time t is:

$$\gamma = \omega_o t + \alpha t^2/2$$

Angle and angular velocity are related by the following equation:

$$\omega^2 - \omega_o^2 = 2\alpha\gamma$$

The work done in accelerating the body is the product of torque and angle of rotation:

$$W = M\gamma$$

The kinetic energy of the body is the product of its moment of inertia and the square of its angular velocity:

$$E_k = J\omega^2/2$$

Since energy is conserved, the work done is equal to the change in kinetic energy (neglecting losses):

$$W = J(\omega^2 - \omega_o^2)/2$$

Power is the product of torque and angular velocity, i.e. the rate at which work is being done:

$$P = M\omega$$

Relationship between linear and angular motion

Consider a body of mass m moving in a circle of radius r with an angular velocity ω , Fig A.13.

When the body has rotated through an angle γ , it has covered a distance s along circumference of the circle, where:

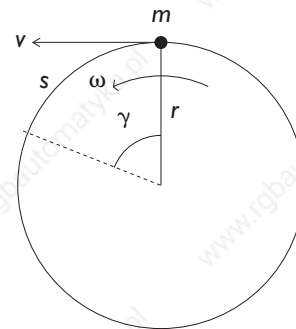

Fig A.13
Relationship
between linear and
angular motion

Similarly, the tangential velocity or peripheral speed v , being the quotient of distance and time, is given by:

$$v = s/t = \gamma r/t$$

Angular velocity w is the quotient of angle and time;

$$w = \gamma/t$$

Therefore

$$v = wr$$

Similarly, for acceleration:

$$a = v/t = wr/t$$

$$\alpha = w$$

Therefore

$$a = \alpha r$$

The moment of inertia is given by

$$J = mr^2$$

The Effect of Gearing

When calculating the torque required to accelerate or decelerate the moving parts of a machine, it is necessary to take into account any gearing which introduces a ratio between the speeds of different parts. It is unusual to calculate the moment of inertia referred to the motor shaft, since this figure may be added arithmetically to the motor inertia to arrive at a figure for the total inertia of the system. Fig A.14 illustrates a motor, having a moment of inertia J_1 , driving a load with inertia J_2 , via a gearbox.

If the gearbox has a ratio k , then the relationship between input and output angular velocities is as follows:

$$\omega_1 = k\omega_2$$

Neglecting losses, the input and output torques are related thus:

$$M_1 = M_2/k$$

The load inertia reflected back through the gearbox to the motor shaft is reduced by a factor equal to the square of the gear ratio. Therefore the total inertia which the motor has to overcome is given by:

$$J = J_1 + J_2/k^2$$

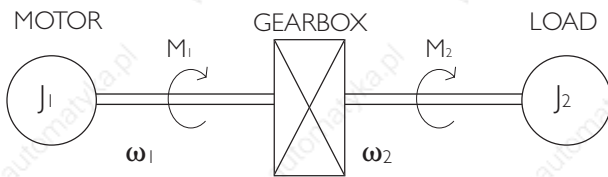
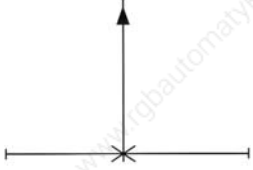
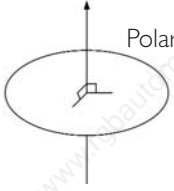
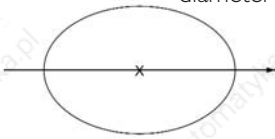
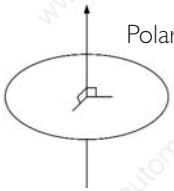
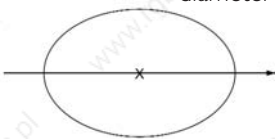
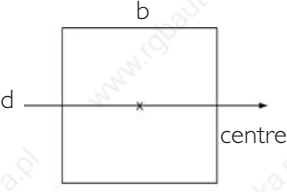
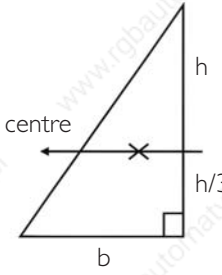
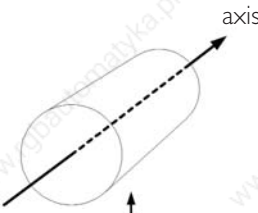
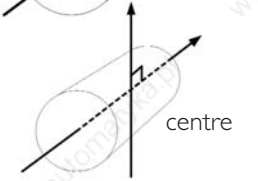
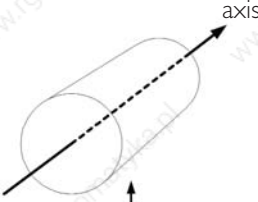
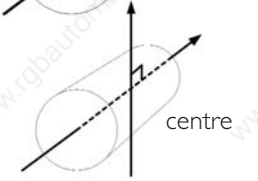
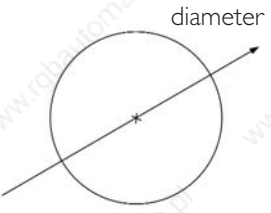
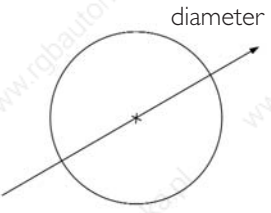

Fig A.14 The effect of gearing between motor and load

INERTIA

Body	Axis	Moment of Inertia(J)
Uniform rod (length l)		$\frac{ml^2}{12}$
Uniform hoop (radius r; diameter d)		mr^2
		$\frac{1}{2}mr^2$
Uniform thin disk (radius r; diameter d)		$\frac{1}{2}mr^2$
		$\frac{1}{4}mr^2$
Rectangular Plate		$\frac{md^2}{12}$
Triangular Plate		$\frac{mh^2}{18}$

Properties of Common Materials

Body	Axis	Moment of Inertia(J)
Solid circular cylinder (radius r)		$\frac{1}{2}mr^2$
		$m\left(\frac{l^2}{12} + \frac{r^2}{4}\right)$
Cylindrical shell (no ends)		mr^2
		$\frac{m}{12}(12r^2 + 5l^2)$
Uniform Solid Sphere (radius r)		$\frac{2mr^2}{5}$
Uniform (radius r)		$\frac{2mr^2}{3}$

Name	Kg/m ³
Aluminium	2,710
Aluminium, strong alloy	2,800
Brass (70Cu/30Zn)	8,500
Bronze(90Cu/10Sn)	8,800
Iron, pure	7,870
Iron, cast grey	7,150
Iron, cast white	7,700
Iron, wrought	7,850
Lead	11,340
Nylon	1,150
Stainless steel (18cr/8Ni)	7,930
Steel, mild	7,860
Steel, piano wire	7,800
Tin	7,300
Titanium	4,540
Wood, Spruce	600
Zinc	7,140

Servo Formulae

Motor Torque Constant	$K_T = \frac{M}{I} \text{ (Nm/A)}$	
Motor Input Volts	$V = IRm + K_E W + L \frac{di}{dt}$	
Motor Regulation	$= \frac{R}{K_E K_T}$	
Developed Torque	$M = M_L + \omega F_i + \alpha (Jm + J_i)$	
RMS Torque,	$M_{RMS} = \sqrt{\frac{M_1^2 t_1 + M_2^2 t_2 + M_3^2 t_3}{(t_1 + t_2 + t_3)}}$	
	Linear	Rotary
Distance, Angle(m, rads)	$s = vt$	$\theta = \omega t$
Velocity, (m/s, rads/second)	$v = s/t$	$\omega = 2\pi n$
Acceleration, (m/s ² , rads/s ²)	$a = v/t$	$a = \omega/t$
Force (N)	$F = m.a.$	
Torque (Nm)	$M = F.r.$	$M = j.a$
Power (W)	$P = F.v.$	$P = M.w.$
Kinetic Energy (J)	$W = \frac{1}{2}mv^2$	$w = \frac{1}{2}j\omega^2$

Motion Equations

Velocity:	$v = u + at$
	$v^2 = u^2 + 2.a.s$
Distance:	$s = ut + \frac{1}{2}at^2$

Area, Volume and Arc Length

Sphere:	$V = \frac{4}{3}\pi r^3, S = 4\pi r^2$
Circular Cone:	$V = \frac{1}{3}r^2 h, S = \pi r l$ (h= vertical height, l = slant height, r = base radius & l ² =h ² +r ²)
Circular Cylinder:	$V = \pi r^2 h, S = 2\pi r l$
Pyramid:	$V = \frac{1}{3} \times (\text{base}) \times (\text{perpendicular height})$
Circle:	$A = \frac{1}{2}r^2 \theta, l = r\theta$
Frustrum of Cone:	$A = \pi \frac{h}{3} (R^2 + Rr + r^2)$
Triangle:	$A = \frac{1}{2}ab \sin C$ $A = \sqrt{s(s-a)(s-b)(s-c)}$ $2s = a + b + c$
Eclipse:	$A = \pi ab$
Spherical cap:	$V = \frac{1}{3}\pi h^2 (3r - h)$ $A = 2\pi r h$

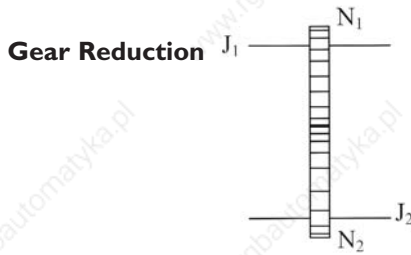

$$J_1 = \left(\frac{n_1}{n_2} \right)^2 \cdot J_2$$

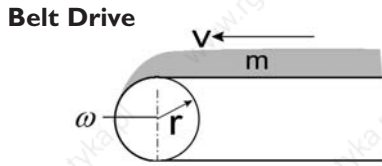

$$J = m \cdot r^2$$

$$J = m(v/\omega)^2$$

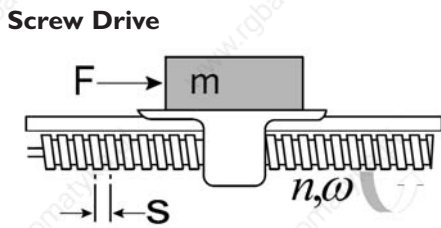

$$J = m \left(\frac{s}{2\pi} \right)^2$$

Inertia Matching

1. For fast acceleration, use 1:1 inertia match.
2. For minimum peak power, use reflected load inertia 2.5 times motor inertia.
3. Generally avoid load inertia higher than 5 times motor inertia

RECTIFIER POWER CONVERSION FORMULAE

Table 1: Rectifier Power Conversion Formulae

Bridge	Pulse No p	V _{dc} av	Form Factor f	Ripple %	AC Input Current I _s rms	Semiconductor Device			
						Current			V _r
						av	rms	peak	peak
Single-phase Half-wave	1	$\frac{\sqrt{2}}{\pi} V_s$ 0.45 V _s	1.57	121	1.57 I _{dc}	I _{dc}	1.57 I _{dc}	3.14 I _{dc}	3.14 V _{dc} 1.41 V _s
Single-phase Half-wave Center-tap	2	$\frac{\sqrt{2}}{\pi} V_s$ 0.45 V _s	1.11	48	0.79 I _{dc}	0.5 I _{dc}	0.79 I _{dc}	1.57 I _{dc}	3.14 V _{dc} 2.82 V _s
Single-phase Full-wave Bridge	2	$\frac{2\sqrt{2}}{\pi} V_s$ 0.90 V _s	1.11	48	1.11 I _{dc}	0.5 I _{dc}	0.79 I _{dc}	1.57 I _{dc}	1.57 V _{dc} 1.41 V _s
Three-phase Half-wave Bridge	3	$\frac{3}{\pi\sqrt{2}} V_s$ 0.67 V _s	1.017	18.3	0.59 I _{dc}	0.33 I _{dc}	0.59 I _{dc}	1.21 I _{dc}	2.09 V _{dc} 2.45 V _s
Three-phase Full-wave Bridge	6	$\frac{3\sqrt{2}}{\pi} V_s$ 1.35 V _s	1.001	4.2	0.82 I _{dc}	0.33 I _{dc}	0.59 I _{dc}	1.05 I _{dc}	1.05 V _{dc} 2.45 V _s
Six-phase Star Conn.	6	$\frac{3}{\pi\sqrt{2}} V_s$ 0.67 V _s	1.001	4.2	0.41 I _{dc}	0.17 I _{dc}	0.41 I _{dc}	1.05 I _{dc}	2.09 V _{dc} 2.83 V _s
Double-3 Star Conn. with IGR	6	$\frac{3}{\pi\sqrt{2}} V_s$ 0.67 V _s	1.001	4.2	0.29 I _{dc}	0.17 I _{dc}	0.29 I _{dc}	1.53 I _{dc}	2.09 V _{dc} 2.45 V _s
Series Star Conn.	12	$\frac{6\sqrt{2}}{\pi} V_s$ 0.67 V _s	1.001	4.1	0.82 I _{dc}	0.33 I _{dc}	0.59 I _{dc}	1.05 I _{dc}	0.53 V _{dc} 1.23 V _s
Parallel Bridge	12	$\frac{3\sqrt{2}}{\pi} V_s$ 1.35 V _s	1.001	4.1	0.41 I _{dc}	0.17 I _{dc}	0.29 I _{dc}	0.53 I _{dc}	1.05 V _{dc} 2.45 V _s
General Calculations			$\frac{V_{dc(rms)}}{V_{dc(av)}}$	$100(f^2 - 1)^{1/2}$	Actual average output voltage = V _{dc} cos φ				

MECHANICAL CONVERSION TABLE

Length

	mm	cm	m	inch	foot	yard	km	Mile
mm	1	10 ⁻¹	10 ⁻³	3.937 × 10 ⁻²	3.280 × 10 ⁻³	1.093 × 10 ⁻³	10 ⁻⁶	6.213 × 10 ⁻⁷
cm	10	1	10 ⁻²	3.937 × 10 ⁻¹	3.280 × 10 ⁻²	1.093 × 10 ⁻²	10 ⁻⁵	6.213 × 10 ⁻⁶
m	1000	100	1	39.3701	3.28084	1.09361	10 ⁻³	6.213 × 10 ⁻⁴
Inch	25.4	2.54	2.54 × 10 ⁻²	1	8.333 × 10 ⁻²	2.777 × 10 ⁻²	2.54 × 10 ⁻⁵	1.578 × 10 ⁻⁵
foot	304.8	30.48	3.048 × 10 ⁻¹	12	1	3.333 × 10 ⁻¹	3.048 × 10 ⁻⁴	1.893 × 10 ⁻⁴
yard	914.4	91.44	9.144 × 10 ⁻¹	36	3	1	9.144 × 10 ⁻⁴	5.681 × 10 ⁻⁴
km	10 ⁶	10 ⁵	1000	39370.1	3280.84	1093.61	1	6.213 × 10 ⁻¹
mile	1.609 × 10 ⁶	160934	1609.34	63360	5280	1760	1.609	1

Mass

	g	kg	oz	lb	US ton
g	1	10 ⁻³	3.5274 × 10 ⁻²	2.204 × 10 ⁻³	1.102 × 10 ⁻⁶
kg	1000	1	35.274	2.20462	1.102 × 10 ⁻³
oz	28.2495	2.835 × 10 ⁻²	1	6.25 × 10 ⁻²	3.125 × 10 ⁻⁵
lb	453.592	4.536 × 10 ⁻¹	16	1	5 × 10 ⁻⁴
US ton	907185	907.185	32	2000	1

Energy

	J	Wh	kp m	k cal	BTU
J	1	2778 × 10 ⁻⁴	1.019 × 10 ⁻¹	2.388 × 10 ⁻⁴	9.478 × 10 ⁻⁴
Wh	3600	1	367.098	8.598 × 10 ⁻¹	3.41214
kp m	9.80665	2.724 × 10 ⁻³	1	2.342 × 10 ⁻³	9.295 × 10 ⁻³
k cal	4186.8	1.163	426.935	1	3.96832
BTU	1055.06	2.931 × 10 ⁻¹	107.586	2.519 × 10 ⁻¹	1

Area

	cm ²	m ²	are	hect.	km ²	inch ²	foot ²	yard ²	mile ²	acre
cm ²	1	10 ⁻⁴	10 ⁻⁶	10 ⁻⁸	10 ⁻¹⁰	1.55 × 10 ⁻¹	1.076 × 10 ⁻³	1.196 × 10 ⁻⁴	3.861 × 10 ⁻¹¹	2.471 × 10 ⁻⁸
m ²	10000	1	10 ²	10 ⁴	10 ⁶	1550	107639	1.19599	3.861 × 10 ⁻⁷	2.471 × 10 ⁻⁴
are	10 ⁶	100	1	10 ⁻²	10 ⁻⁴	155000	1076.39	119599	3.861 × 10 ⁻⁵	2.471 × 10 ⁻²
hectare	10 ⁸	10000	100	1	10 ⁻²	1.55 × 10 ⁷	107639	11959.9	3.861 × 10 ⁻³	2.47105
km ²	10 ¹⁰	10 ⁶	10000	100	1	1.55 × 10 ⁹	1.076 × 10 ⁷	1.196 × 10 ⁶	3.861 × 10 ⁻¹	247.105
inch ²	6.4516	6.4516 × 10 ⁻⁴	6.4516 × 10 ⁻⁶	6.4516 × 10 ⁻⁸	6.4516 × 10 ⁻¹⁰	1	6.944 × 10 ⁻³	7.716 × 10 ⁻⁴	2.491 × 10 ⁻¹⁰	1.594 × 10 ⁻⁷
foot ²	929.03	9.2903 × 10 ⁻²	9.2903 × 10 ⁻⁴	9.2903 × 10 ⁻⁶	9.2903 × 10 ⁻⁸	144	1	1.1111 × 10 ⁻¹	3.587 × 10 ⁻⁸	2.295 × 10 ⁻⁵
yard ²	8.36127	8.36127 × 10 ⁻¹	8.36127 × 10 ⁻³	8.36127 × 10 ⁻⁵	8.36127 × 10 ⁻⁷	1296	9	1	3.228 × 10 ⁻⁷	2.066 × 10 ⁻⁴
mile ²	2.589 × 10 ¹⁰	2.589 × 10 ⁶	25899.9	258.999	2.58999	4.014 × 10 ⁹	2.787 × 10 ⁷	2.0976 × 10 ⁶	1	640
acre	4.046 × 10 ⁷	4046.86	40.4686	4.04686 × 10 ⁻¹	4.04686 × 10 ⁻³	6.272 × 10 ⁶	43560	4840	1.5625 × 10 ⁻³	1

Volume

	cm ³	dm ³ (=litre)	inch ³	foot ³	yard ³	US fl oz	Imp fl oz	US gal	Imp gal	Imp pint
cm ³	1	10 ⁻³	6.102 × 10 ⁻²	3.531 × 10 ⁻⁵	1.308 × 10 ⁻⁶	3.3814 × 10 ⁻²	3.519 × 10 ⁻²	2.641 × 10 ⁻⁴	2.199 × 10 ⁻⁴	1.759 × 10 ⁻³
dm ³	1000	1	61.0237	3.531 × 10 ⁻²	1.308 × 10 ⁻³	33.814	35.1951	2.641 × 10 ⁻¹	2.199 × 10 ⁻¹	1.75975
inch ³	16.3871	1.638 × 10 ⁻²	1	5.787 × 10 ⁻⁴	2.143 × 10 ⁻⁵	5.541 × 10 ⁻¹	5.767 × 10 ⁻¹	4.329 × 10 ⁻³	3.604 × 10 ⁻³	2.883 × 10 ⁻²
foot ³	28316.8	28.3168	1728	1	3.7037 × 10 ²	957.506	996.614	7.48052	6.22884	49.8307
yard ³	764555	764.555	46656	27	1	25852.7	26.908.6	201.974	168.179	1345.43
US fl oz	29.5735	2.957 × 10 ⁻²	1.80469	1.044 × 10 ⁻³	3.868 × 10 ⁻⁵	1	1.04084	7.8125 × 10 ⁻³	6.505 × 10 ⁻³	5.204 × 10 ⁻²
Imp fl oz	28.4131	2.841 × 10 ⁻²	1.73387	1.003 × 10 ⁻³	3.716 × 10 ⁻⁵	9.6076 × 10 ⁻¹	1	7.506 × 10 ⁻³	6.25 × 10 ⁻³	5 × 10 ⁻²
US gal	3785.41	3.78541	231	1.336 × 10 ⁻¹	4.951 × 10 ⁻³	128	133.228	1	8.326 × 10 ⁻¹	6.66139
Imp gal	4546.09	4.54609	277.149	1.605 × 10 ⁻¹	5.946 × 10 ⁻³	153.772	160	1.20095	1	8
Imp pint	568.261	5.682 × 10 ⁻¹	34.6774	2.0068 × 10 ⁻²	7.432 × 10 ⁻⁴	19.2152	20	1.501 × 10 ⁻¹	1.25 × 10 ⁻¹	1

Inertia

	kg cm ²	kp cm s ²	kg m ²	kp m s ²	oz in ²	oz in s ²	lb in ²	lb in s ²	lb ft ²	lb ft s ²
kg cm ²	1	1.019 × 10 ⁻³	10 ⁻⁴	1.019 × 10 ⁻⁵	5.46748	1.416 × 10 ⁻²	3.417 × 10 ⁻¹	8.850 × 10 ⁻⁴	2.373 × 10 ⁻³	7.375 × 10 ⁻⁵
kp cm s ²	980.665	1	9.806 × 10 ⁻¹²	10 ⁻²	5361.76	13.8874	335.11	8.679 × 10 ⁻¹	2.32715	7.233 × 10 ⁻²
kg m ²	10 ⁴	10.1927	1	1.019 × 10 ⁻¹	54674.8	141.612	3417.17	8.85075	23.7304	7.375 × 10 ⁻¹
kp m s ²	98066.5	100	9.86065	1	536176	1388.74	33511	86.7962	232.715	7.23301
oz in ²	1.829 × 10 ⁻¹	1.865 × 10 ⁻⁴	1.829 × 10 ⁻⁵	1.865 × 10 ⁻⁶	1	2.590 × 10 ⁻³	6.25 × 10 ⁻²	1.6188 × 10 ⁻⁴	2.340 × 10 ⁻⁴	7.349 × 10 ⁻⁵
oz in s ²	70.6155	7.201 × 10 ⁻²	7.061 × 10 ⁻³	7.200 × 10 ⁻⁴	386.089	1	24.1305	6.25 × 10 ⁻²	1.675 × 10 ⁻¹	5.208 × 10 ⁻³
lb in ²	2.9264	2.984 × 10 ⁻³	2.9264 × 10 ⁻⁴	2.984 × 10 ⁻⁵	16	4.144 × 10 ⁻²	1	2.590 × 10 ⁻³	6.944 × 10 ⁻³	2.1548 × 10 ⁻⁴
lb in s ²	1129.85	1.15212	1.29 × 10 ⁻¹	1.152 × 10 ⁻²	6177.42	16	386.089	1	2.68117	8.333 × 10 ⁻²
lb ft ²	421.401	4.297 × 10 ⁻¹	4.214 × 10 ⁻²	4.2971 × 10 ⁻³	2304	5.96754	144	3.729 × 10 ⁻¹	1	3.108 × 10 ⁻²
lb ft s ²	13558.2	13.8255	1.355	1.382 × 10 ⁻¹	74129	192	4633.06	12	32.174	1

Torque

	N cm	Nm	kp cm	kp m	p cm	oz in	in lb	ft lb
N cm	1	10 ⁻²	1.019 × 10 ⁻¹	1.019 × 10 ⁻³	101.972	1.41612	8.850 × 10 ⁻²	7.375 × 10 ⁻³
Nm	100	1	10.1972	1.019 × 10 ⁻¹	10197.2	141.612	8.85075	7.375 × 10 ⁻¹
kp cm	9.80665	9.806 × 10 ⁻²	1	10 ⁻²	1000	13.8874	8.679 × 10 ⁻¹	7.233 × 10 ⁻²
kp m	980.665	9.80665	100	1	10 ⁵	1388.74	86.7962	7.23301
p cm	9.806 × 10 ⁻³	9.806 × 10 ⁻⁵	10 ⁻³	10 ⁻⁵	1	1.388 × 10 ⁻²	8.679 × 10 ⁻⁴	7.233 × 10 ⁻⁵
oz in	7.061 × 10 ⁻¹	7.061 × 10 ⁻³	7.200 × 10 ⁻²	7.200 × 10 ⁻⁴	72.0078	1	6.25 × 10 ⁻²	5.208 × 10 ⁻³
in lb	11.2985	1.129 × 10 ⁻¹	1.15212	1.152 × 10 ⁻²	1152.12	16	1	8.333 × 10 ⁻²
ft lb	135.582	1.35582	13.8225	1.382 × 10 ⁻¹	13825.5	192	12	1

Force

	N	kp	p	oz	lbf
N	1	1.019 × 10 ⁻¹	101.972	3.59694	2.248 × 10 ⁻¹
kp	9.80665	1	1000	35.274	2.20462
p	9.806 × 10 ⁻³	10 ⁻³	1	3.5274 × 10 ⁻²	2.204 × 10 ⁻³
oz	2.780 × 10 ⁻¹	2.835 × 10 ⁻²	28.3495	1	6.25 × 10 ⁻²
lbf	4.44822	4.536 × 10 ⁻¹	453.592	16	1

Power

	kW	PS	hp	kp m s ⁻¹	kcal s ⁻¹
kW	1	1.35962	1.34102	101972	2.388 × 10 ⁻¹
PS	7.355 × 10 ⁻¹	1	9.8632 × 10 ⁻¹	75	1.756 × 10 ⁻¹
hp	7.457 × 10 ⁻¹	1.01387	1	76.0402	1.781 × 10 ⁻¹
kp m s ⁻¹	9.806 × 10 ⁻³	1.333 × 10 ⁻²	1.3515 × 10 ⁻²	1	2.342 × 10 ⁻³
kcal s ⁻¹	4.1868	5.69246	5.61459	426.935	1

GENERAL CONVERSION TABLES

Length

SI UNIT - metre (m)		
To convert from:	To:	Multiply by:
Mile	m	1609.344
Nautical Mile	m	1853
km	m	10 ³
cm	m	10 ⁻²
mm	m	10 ⁻³
yd	m	0.9144
ft	m	0.3048
in	m	2.54 × 10 ⁻²
mil	m	2.54 × 10 ⁻⁵

Area

SI UNIT - square metre (m ²)		
To convert from:	To:	Multiply by:
Square Miles	m ²	2.59 × 10 ⁶
Acre	m ²	4047
Hectare ha	m ²	10 ⁴
km ² (sq. km)	m ²	10 ⁶
cm ²	m ²	10 ⁻⁴
mm ²	m ²	10 ⁻⁶
yd ²	m ²	0.8361
ft ²	m ²	9.29 × 10 ⁻²
in ²	m ²	6.45 × 10 ⁻⁴
mil ²	m ²	6.45 × 10 ⁻¹⁰

Volume

SI UNIT - cubic metre (m ³)		
To convert from:	To:	Multiply by:
yd ³	m ³	0.765
ft ³	m ³	2.83 × 10 ⁻²
in ³	m ³	1.64 × 10 ⁻⁴
dm ³	m ³	10 ⁻³
Litre	m ³	10 ⁻³
Gallon (Imperial)	m ³	4.55 × 10 ⁻³
Gallon (U.S.)	m ³	3.79 × 10 ⁻³
Pint (Imperial)	m ³	5.68 × 10 ⁻⁴
Pint (U.S.)	m ³	4.73 × 10 ⁻⁴

Mass

SI UNIT - kilogram (kg)		
To convert from:	To:	Multiply by:
ton (Imperial)	kg	1016
ton (U.S.)	kg	907.2
tonne (metric)	kg	10 ³
slug	kg	14.59
lb	kg	0.4536
oz	kg	2.84 × 10 ⁻²
g	kg	10 ⁻³

Force and Weight

SI UNIT - Newton (N)		
To convert from:	To:	Multiply by:
tonf (ton wt)	N	9964
lbf (lb wt)	N	4.448
poundal	N	0.1383
ozf (oz wt)	N	0.2780
kp	N	9.807
p	N	9.81 × 10 ⁻²
kgf (kg wt)	N	9.807
gf (g wt)	N	9.81 × 10 ⁻²
dyn	N	10 ⁻⁵

Pressure and Stress

SI UNIT - Pascal (Pa)		
To convert from:	To:	Multiply by:
at (technical atmosphere)	Pa	9.81 × 10 ³
in WG	Pa	248.9
mm WG	Pa	10.34
in HG	Pa	3385
mm HG (torr)	Pa	131.0
kp cm ⁻²	Pa	9.81 × 10 ³
Nm ⁻²	Pa	1.0
bar	Pa	10 ⁵
lbf ft ⁻²	Pa	47.88
lbf in ⁻²	Pa	6895
kgf m ⁻²	Pa	9.807
kgf cm ⁻²	Pa	9.81 × 10 ⁴

Velocity (Linear)

SI UNIT - metre per second (ms ⁻¹)		
To convert from:	To:	Multiply by:
mph (mile per hour)	ms ⁻¹	0.4470
ft min ⁻¹	ms ⁻¹	5.08 × 10 ⁻³
ft s ⁻¹	ms ⁻¹	0.3048
km h ⁻¹	ms ⁻¹	0.2778
m min ⁻¹	ms ⁻¹	1.67 × 10 ⁻²
knot	ms ⁻¹	0.5145

Velocity (Angular)

SI UNIT - radians per second (rad s ⁻¹)		
To convert from:	To:	Multiply by:
rpm (revolutions per min)	rad s ⁻¹	0.1037 (2π/60)
r s ⁻¹ (revolutions per sec)	rad s ⁻¹	6.283 (2π)
°s ⁻¹ (degrees per sec)	rad s ⁻¹	1.75 × 10 ⁻² (2π/360)

Torque

SI UNIT - Newton meter (Nm)		
To convert from:	To:	Multiply by:
lbf ft	Nm	1.356
lbf in	Nm	0.1129
ozf in	Nm	7.062 × 10 ⁻³
kgf m	Nm	9.8067
kp m	Nm	9.8067

Energy

SI UNIT - Joule (J)		
To convert from:	To:	Multiply by:
Btu	J	1.055 × 10 ³
therm (10 ⁵ btu)	J	1.055 × 10 ⁸
cal	J	4.187
ft lbf (ft lb wt)	J	1.356
ft poundal	J	0.0421

Power

SI UNIT - kilowatt (kW)		
To convert from:	To:	Multiply by:
hp	kW	0.7457
ps	kW	0.7355
ch, CV	kW	0.7355
Btu s ⁻¹	kW	1.055
kcal s ⁻¹	kW	4.1868
ft lbf s ⁻¹	kW	1.36 × 10 ⁻³

Moment of Inertia

SI UNIT - kilogram metre ² (kgm ²)		
To convert from:	To:	Multiply by:
lb in ²	kgm ²	0.113
oz in ²	kgm ²	7.06155 × 10 ⁻²
kg m ²	lb in ²	8.85075
kg m ²	oz in ²	141.612
kg cm ²	kg m ²	10 ⁻⁴

Moment of Inertia

SI UNIT - Kilogram metre ² (kgm ²)		
To convert from:	To:	Multiply by:
kgf m ² (GD2)	kgm ²	0.25
lbf ft ² (WK2)	kgm ²	4.21 × 10 ⁻²
kp m s ²	kgm ²	9.807
ft lbf s ²	kgm ²	1.356
lbf in ²	kgm ²	2.926 × 10 ⁻⁴
ozf in ²	kgm ²	1.829 × 10 ⁻⁵

Temperature

SI UNIT - Kelvin (K)		
To convert from:	To:	Multiply by:
°C	K	× 1
t°C	K	t+273.15
°F	K	× 0.5555
t°F	K	(t-32) × 0.5555

Flow

SI UNIT - cubic metre per second (m ³ s ⁻¹)		
To convert from:	To:	Multiply by:
gallon per hour (Imp)	m ³ s ⁻¹	1.26×10 ⁻⁶
gallon per hour (US)	m ³ s ⁻¹	1.05×10 ⁻⁶
litre per hour	m ³ s ⁻¹	1.67×10 ⁻⁵
litre per second	m ³ s ⁻¹	10 ⁻³
cfm	m ³ s ⁻¹	4.72×10 ⁻⁴
m ³ h ⁻¹	m ³ s ⁻¹	2.78×10 ⁻⁴
m ³ min ⁻¹	m ³ s ⁻¹	1.67×10 ⁻²

Torque

SI UNIT - Newton metre (Nm)		
To convert from:	To:	Multiply by:
lb ft	Nm	1.356
lb in	Nm	0.1129
oz in	Nm	7.062 × 10 ⁻³
Nm	lb ft	0.7375
Nm	lb ft	8.857
Nm	oz in	141.6

Force

SI UNIT - Newton (N)		
To convert from:	To:	Multiply by:
lb(f)	N	4.4482
N	lb(f)	0.22481

Linear Acceleration

SI UNIT - metre per second ² (ms ⁻²)		
To convert from:	To:	Multiply by:
in s ⁻²	ms ⁻²	2.54 × 10 ⁻²
ft s ⁻²	ms ⁻²	0.3048
ms ⁻²	in s ⁻²	39.37
ms ⁻²	ft s ⁻²	3.2808

Driving the world...



Drive & Application Centres

AUSTRALIA

Melbourne Application Centre
A.C.N. 003 815 281
Tel: 613 973 81777
Fax: 613 9729 3200
After Hours: 61 2 9963 5271

Sydney Drive Centre
A.C.N. 003 815 281
Tel: 61 2 9838 7222
Fax: 61 2 9838 7764
After Hours: 61 2 9963 5271

AUSTRIA

Linz Drive Centre
Tel: 43 7229 789480
Fax: 43 7229 789480
After Hours: 43 7215 3502

BELGIUM

Brussels Drive Centre
Tel: 32 1574 0700
Fax: 32 1574 0799

BRAZIL

Sao Paulo Application Centre
Tel: 55 11 3618 5959
Fax: 55 11 3618 6611

CANADA

Toronto Drive Centre
Tel: 1 905 201 4699
Fax: 1 905 201 4694
After Hours: 1 800 893 2321

CHINA

Shanghai Drive Centre
Tel: 86 21 5426 0668
Fax: 86 21 5426 0669

Beijing Application Centre
Tel: 86 10 856 31122 ext 820
Fax: 86 10 856 35029

CZECH REPUBLIC

Brno Drive Centre
Tel: 420 541 192111
Fax: 420 541 192115
After Hours: 420 541 192 119

DENMARK

Copenhagen Drive Centre
Tel: 45 4369 6100
Fax: 45 4369 6101
After Hours: 45 4369 6100

FINLAND

Helsinki Drive Centre
Tel: 358 985 2661
Fax: 358 985 26823
After Hours: 358 500 423271

FRANCE

Angouleme Drive Centre
Tel: 33 5 4564 5454
Fax: 33 5 4564 5400

GERMANY

Bonn Drive Centre
Tel: 49 2242 8770
Fax: 49 2242 877277
After Hours: 49 1714 964777

CHEMNITZ DRIVE CENTRE

Tel: 49 3722 52030
Fax: 49 3722 520330
After Hours: 49 1714 964777

DARMSTADT DRIVE CENTRE

Tel: 49 6251 17700
Fax: 49 6251 177098
After Hours: 49 1714 964777

GREECE

Athens Application Centre
Tel: 0030 210 57 86086/088
Fax: 0030 210 57 86087

HOLLAND

Rotterdam Drive Centre
Tel: 31 184 420555
Fax: 31 184 420721
After Hours: 31 184 420555

HONG KONG

Hong Kong Application Centre
Tel: 852 2979 5271
Fax: 852 2979 5220
After Hours: 852 2979 5271

INDIA

Mumbai Application Centre
Tel: 91 20 612 7956, 612 8415
Fax: 91 20 611 3312

Kolkata Application Centre
Tel: 91 33 2357 5302/2357 5306
Fax: 91 33 2357 3435
After Hours: 91 98 3004 8562

CHENNAI DRIVE CENTRE

Tel: 91 44 2496 1123/
2496 1130/2496 1083
Fax: 91 44 2496 1602
After Hours: 91 44 2496 1083

NEW DELHI APPLICATION CENTRE

Tel: 91 11 21 576 4782/
91 11 2 581 3166
Fax: 91 11 51 539216

IRELAND

Dublin Drive Centre
Tel: 353 45 448200
Fax: 353 45 433622

ITALY

Milan Drive Centre
Tel: 39 02575 751
Fax: 39 02575 12858
After Hours: 39 02575 751

Vicenza Drive Centre
Tel: 39 0444 396200
Fax: 39 0444 341317
After Hours: 39 02 575 751

KOREA

Seoul Application Centre
Tel: 82 31 703 7169
Fax: 82 31 703 7168
After Hours: 82 31 703 7185

MALAYSIA

Kuala Lumpur Drive Centre
Tel: 603 5634 9776
Fax: 603 5633 9592
After Hours: 60 12 333 8355

REPUBLIC OF SOUTH AFRICA

Johannesburg Drive Centre
Tel: 27 11 462 1740
Fax: 27 11 462 1941
After Hours: 27 11 462 1740

RUSSIA

Moscow Application Centre
Tel: 7 095 232 9472
Fax: 7 095 956 4862

SINGAPORE

Singapore Drive Centre
Tel: 65 6468 8979
Fax: 65 6468 6982
After Hours: 65 9752 5828/
9636 0323

SPAIN

Barcelona Drive Centre
Tel: 34 93 680 1661
Fax: 34 93 680 0903
/34 93 680 2823
After Hours: 34 610 554540

Bilbao Application Centre
Tel: 34 94 620 3646
Fax: 34 94 681 1406
After Hours: 34 61 055 4547

Valencia Drive Centre
Tel: 34 96 154 2900
Fax: 34 96 153 2906
After Hours: 34 66 642 8514

SWEDEN

Stockholm Application Centre
Tel: 468 554 241 00
Fax: 468 554 241 10
After Hours: 467 044 183 29

SWITZERLAND

Lausanne Application Centre
Tel: 41 21 637 7070
Fax: 41 21 637 7071
After Hours: 41 79 357 8683

ZURICH DRIVE CENTRE

Tel: 41 56 201 4242
Fax: 41 56 201 4243
After Hours: 41 79 357 8683

TAIWAN

Taipei Application Centre
Tel: 886 22325 9555
Fax: 886 22705 9131
After Hours: 886 92186 6502

THAILAND

Bangkok Drive Centre
Tel: 66 2580 7644
Fax: 66 2591 4559
A/Hours Sales: 66 1443 4095
A/Hours Service: 66 1443 4098

TURKEY

Istanbul Drive Centre
Tel: 90 216 4182420
Fax: 90 216 4182423
After Hours: 90 216 418 2420

UAE

Dubai Application Centre
Tel: 971 4 883 8650
Fax: 971 4 883 8651

UNITED KINGDOM

Telford Drive Centre
Tel: 44 1952 213700
Fax: 44 1952 213701
After Hours: 44 1952 213700

USA

Charlotte Application Centre
Tel: 1 704 393 3366
Fax: 1 704 393 0900
After Hours: 1 800 893 2321

Chicago Application Centre
Tel: 1 630 752 9090
Fax: 1 630 752 9555
After Hours: 1 800 893 2321

CLEVELAND DRIVE CENTRE

Tel: 1 440 717 0123
Fax: 1 440 717 0133
After Hours: 1 800 893 2321

MINNEAPOLIS US HEADQUARTERS

Tel: 1 952 995 8000
Fax: 1 952 995 8020/8099
After Hours: 1 800 893 2321

PROVIDENCE DRIVE CENTRE

Tel: 1 401 541 7277
Fax: 1 401 541 7266
After Hours: 1 800 893 2321

- Drive & Application Centres
- Distributors

ARGENTINA

Euro Techniques SA
Tel: 54 11 4331 7820
eurotech@eurotechsa.com.ar

BAHRAIN

Itikhar Electrical Est.
Tel: 973 271 1116
ieepower@batelco.com.bh

BRAZIL

ACIEL Comercio e Servicos LTDA
Tel: 55 11 5565 5798
aciell@aciell.com.br

Postronic Sistemas Industriais Ltda.
Tel: 55 11 3832 2738
info@postronic.com.br

CHILE

Ingenieria y Desarrollo
Tecnologico SA
Tel: 56 (2) 741 9624
idt@idt.cl

COLOMBIA

Sistronic LTDA
Tel: 57 1 410 04 24
jonesdug@colomsat.net.co

CROATIA

Koncar - MES d.d.
Tel: 385 1 366 7273
nabava@koncar-mes.hr

CYPRUS

Acme Industrial Electronic
Services Ltd
Tel: 3572 5 332181
acme@cyartnet.com.cy

EGYPT

Samiram
Tel: 202 7603877/202 7605950
corporate@samiram.com

HUNGARY

Control-VH Kft
Tel: 361 431 1160
info@controlvh.hu

ICELAND

Samey ehf
Tel: 354 510 5200
samey@samey.is

INDONESIA

Pt Apikon Indonesia
Tel: 65 6468 8979
oowc@controltechniques.com.my

ISRAEL

Dor Drives Systems Ltd
Tel: 972 3900 7595
info@dor1.co.il

KENYA

Kassam & Bros Co. Ltd
Tel: 2540 2 556 418
650268 557136
kasbro@insightkenya.com

KUWAIT

Saleh Jamal & Company WLL
Tel: 965 483 2358
sjceng@almullagroup.com

LEBANON

Black Box Automation & Control
Tel: 961 1 443773
info@blackboxcontrol.com

MALTA

Melanka Limited
Tel: 35621 442 039
mfrancaica@gasan.com

Distributors

MEXICO

MELCSA
Tel: 52 5 561 1312
melcsamx@iserve.net.mx

MOROCCO

Leroy Somer Maroc
Tel: 212 22 354948
lsmaroc@wanadoo.pro.ma

NEW ZEALAND

Electrade New Zealand
Tel: 64 9525 1753
kevin@electrade.co.nz

PHILIPPINES

Busbarr Corp.
Tel: 632 776 0066
sales@busbarr.com.ph

POLAND

APATOR CONTROL Sp. z o.o.
Tel: 48 56 6191 207
drives@apatorun.pl

PORTUGAL

Harker Sumner SA
Tel: 351 22 947 8090
drives.automation@harker.pt

QATAR

AFI Sitna Technologies
Tel: 974 468 4442
jp33@qatar.net.qa

ROMANIA

Dor Drives International
Tel: 40 21 337 3465
dordrive@zappmobile.ro

SAUDI ARABIA

A. Abunayyan Electric Corp.
Tel: (966) 477 9111
aec-salesmarketing@
abunayyanguroup.com

SERBIA & MONTENEGRO

Master Inzenjering d.o.o.
Tel: 381 24 551 605
master@eunet.yu

SLOVAKIA

EMERSON A.S.
Tel: +421 32 7700 369
petersk@uma.sk

SLOVENIA

PS Logotec
Tel: 386 1 750 8510
Email: ps-log@ps-log.si

TUNISIA

SIA Ben Djemaa & CIE
Tel: 216 1 332 923
Email: benjemaa@planet.tn

URUGUAY

Secoin S.A.
Tel: 5982 2093815
Email: secoin@adinet.com.uy

VENEZUELA

Vertix Instrumentos, S.A.
Tel: 58 281 267 4115

VIETNAM

N.D.Duc Thinh
Tel: 84 8 9490633
Email: infotech@nducthinh.com.vn