

Product Catalog System 2003 I/Os, Fieldbuses, and Controllers

Perfection in Automation
www.br-automation.com



Imprint

Providing a high-quality catalog is very important to us. In spite of this conscientious approach, however, B&R cannot guarantee or assume liability for the correctness, timeliness, or completeness of the contents and information contained herein. B&R shall not be held liable for possible tangible or intangible damages caused by incorrect or incomplete information unless proven to be caused by intent or gross negligence on the part of B&R. We additionally reserve the right to update the contents and technical characteristics of the products contained herein at any time.

Product Catalog System 2003 - I/Os, Fieldbusses, and Controllers

Publisher:
Bernecker + Rainer Industrie-Elektronik Ges.m.b.H
B&R Strasse 1
5142 Eggelsberg
Austria

Tel.: +43 (0) 7748/6586-0
Fax: +43 (0) 7748/6586-26

info@br-automation.com
www.br-automation.com

Photo credits: B&R

Printing and processing:
Vorarlberger Verlagsanstalt AG, Dornbirn, Austria
www.vva.at

MM-E00631.416

Table of contents

System characteristics	4
Typical topologies	6
Product overview	10
Product data sheets	20
Accessories	107
Mechanical and electrical configuration	114
Index	128

System characteristics

The B&R System 2003 can be used as both a universal controller system as well as a remote I/O system for expansion of industrial PCs and controllers from all B&R system families. Distributed controller systems can also be implemented. Many different interfaces for fieldbus systems and networks guarantee trouble-free communication.



CPUs

System 2003 central processing units cover the wide performance spectrum. The optimal price/performance ratio is achieved by tuning processing power, memory capacity, integrated communication interfaces, and local slots for I/O screw-in modules. Clearly arranged diagnostic LEDs have been implemented to indicate the controller's status. Programming takes place in a uniform manner using B&R Automation Studio.



Bus controllers

When using the System 2003 as a remote I/O system, bus controllers are available for CAN bus, ETHERNET Powerlink and X2X Link connection. Bus controllers handle the local peripherals and forward I/O signals via the network.



I/O modules

For the System 2003, B&R offers a large number of I/O modules in various designs. Analog values, digital signals, timers and counters allow many process variables to be handled and various actuators to be controlled.



Screw-in modules

Using screw-in modules, the System 2003 can be fine-tuned even further for connecting to process signals on the machine or system. Granularity down to the individual channels allows controller components to be optimized according to the signals being processed.



Network and fieldbus modules

System 2003 CPUs are equipped with the most important interfaces by default. A large number of additional interface modules are available to expand and upgrade the System 2003 and improve contact to the outside world. Connections for all important networks and fieldbus systems exist, ranging from simple serial RS232 connections via Profibus DP to ETHERNET Powerlink.

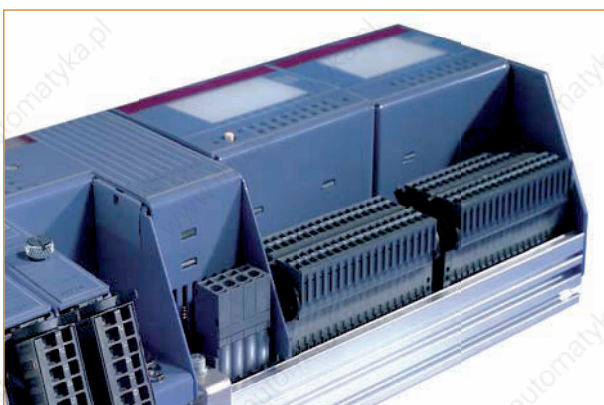

Mounting and supply

Mechanically, the System 2003 is based on a flexible module rack concept, which allows tool-free mounting on DIN rail. CPUs, I/O modules, bus controllers and interfaces are simply installed one after the other in the module rack. Sensor and actuator signal connections can be preconfigured on plug-in terminal blocks, which minimizes work in the switching cabinet. The System 2003 supply is connected to the CPUs, which are available in various AC and DC models.

Typical topologies

Cost-effective compact controller

Extremely cost-effective compact controllers can be built with the System 2003. The compact dimensions save valuable space in the switching cabinet. Networking via CAN bus allows simple connection of operator panels, visualization units, drives and other groups of peripherals. CPUs from various performance classes guarantee an optimal price/performance ratio.

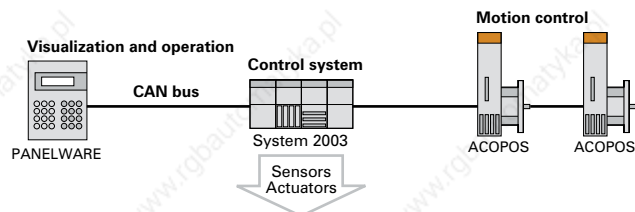

Components and technologies

Control system	System 2003: Compact controllers, remote I/O
Visualization and operation	PANELWARE: Compact operator panels
Motion control	ACOPOS: Intelligent servo drives
	Synchronous motors: Dynamic precision drives
Network and fieldbus modules	CAN bus

Remote I/O system

The System 2003 allows flexible creation of remote I/O stations in a machine or system. Many network and fieldbus interfaces allow connections to the complete spectrum of B&R automation systems and many other systems as well. The large number of different screw-in modules provides connections for any sensor or actuator signal. Programming a remote system is no different than programming a centralized system.

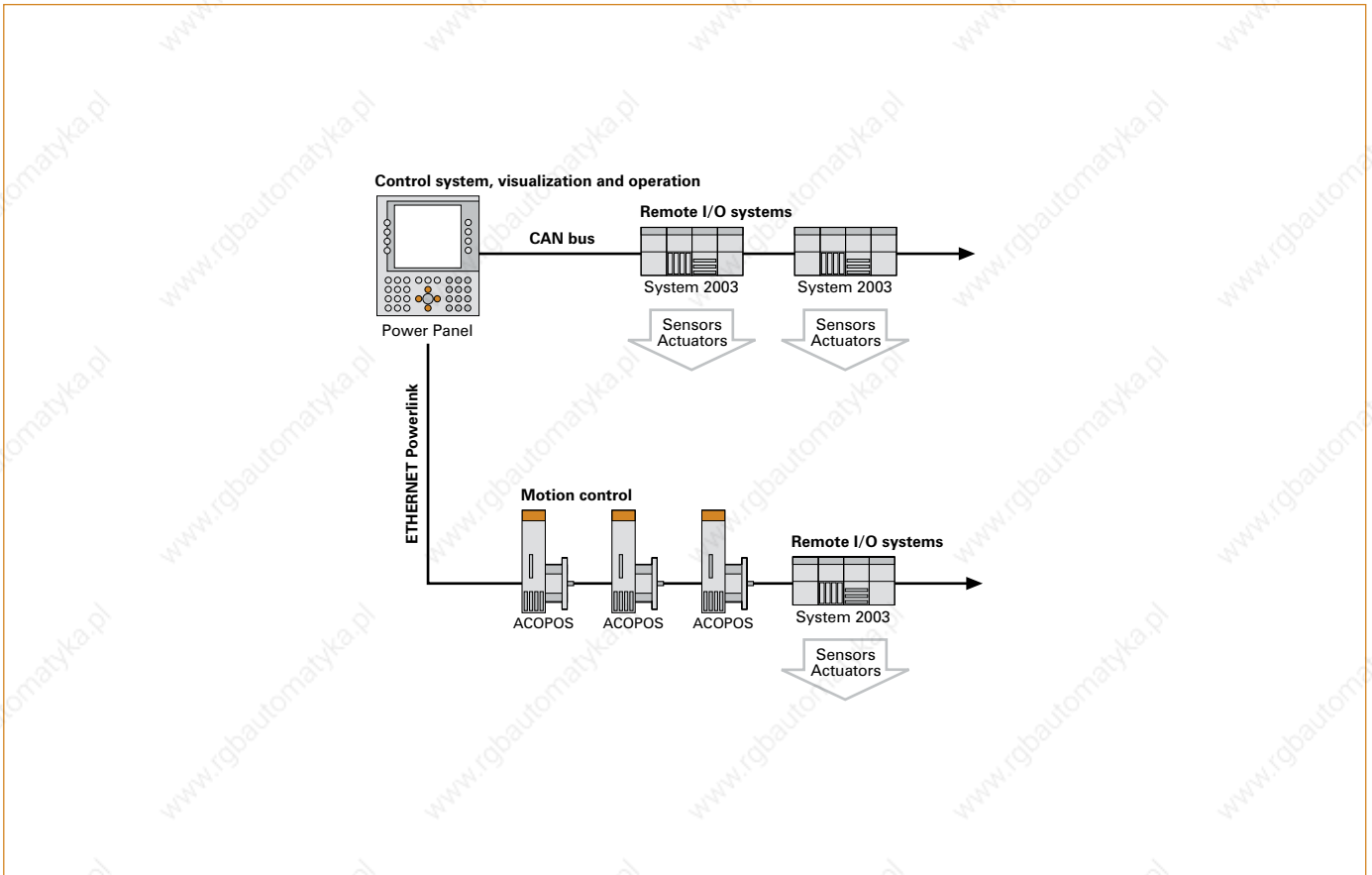

Components and technologies

Control system	Power Panel: Integrated control, operation, and visualization
Visualization and operation	Power Panel: Integrated control, operation, and visualization
Motion control	ACOPOS: Intelligent servo drives Synchronous motors: Dynamic precision drives
Remote input/output systems	System 2003: Compact controllers, remote I/O
Network and fieldbus modules	CAN bus ETHERNET Powerlink

Typical topologies

Control system with distributed intelligence

The System 2003 is ideally suited for the distribution of machines and systems in self-sufficient units or cells with integrated intelligence. Line communication between the units takes place using standard Ethernet TCP/IP networks or fieldbuses. In each unit, the System 2003 can be expanded with drives, operator panels or peripherals. The palette of CPUs allows the computing power to be matched to the requirements of the machine unit.

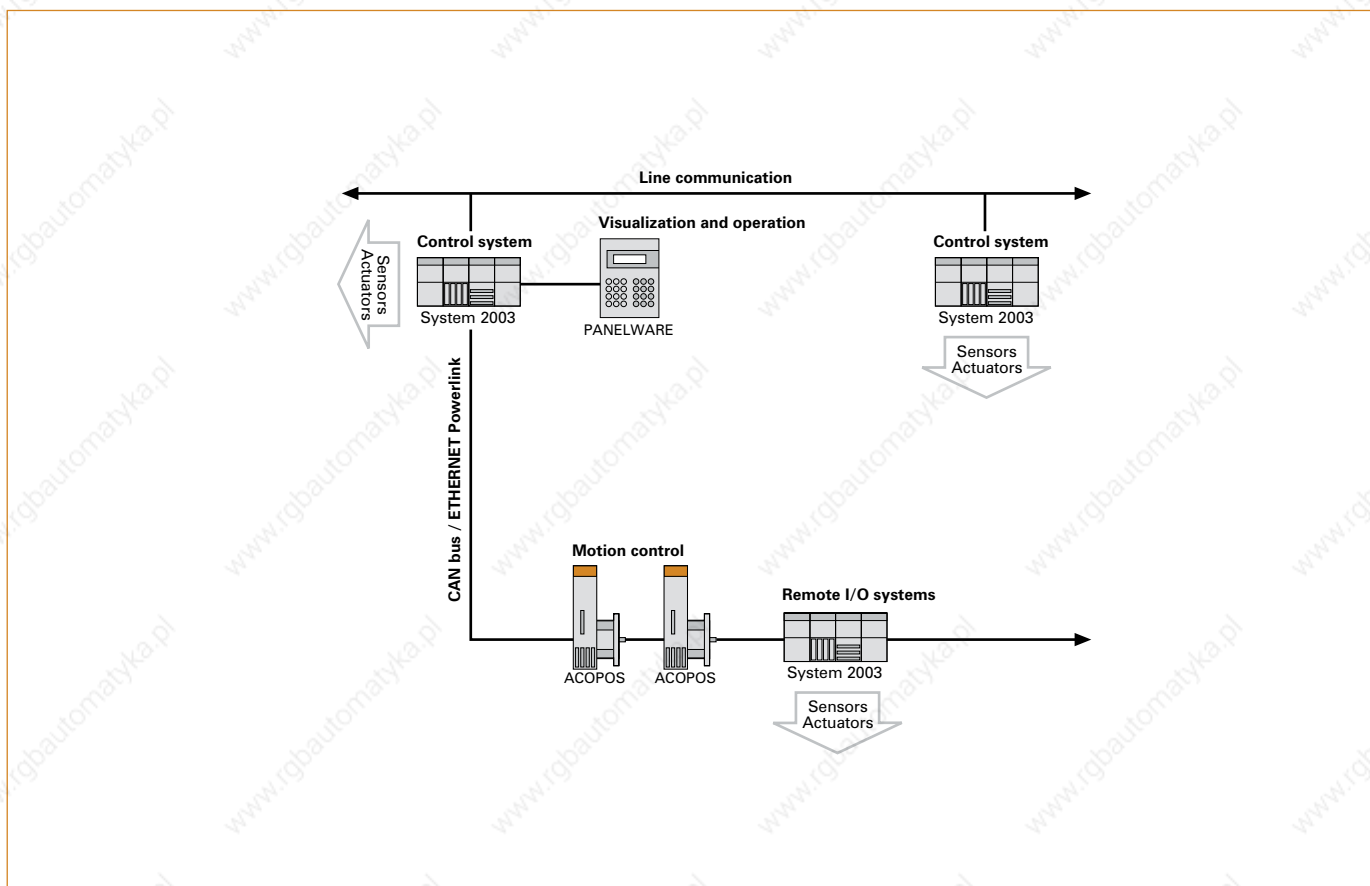

Components and technologies

Control system	System 2003: Compact controllers, remote I/O
Visualization and operation	PANELWARE: Compact operator panels
Motion control	ACOPOS: Intelligent servo drives Synchronous motors: Dynamic precision drives
Remote input/output systems	System 2003: Compact controllers, remote I/O
Network and fieldbus modules	Within the machine CAN bus ETHERNET Powerlink Host/line communication Ethernet TCP/IP

High-performance compact automation

The System 2003 has much more to offer. The compact controller is also suited for large tasks. If the CPU with local I/O system is networked via ETHERNET Powerlink with the various decentralized components, a very powerful system is created for demanding tasks with highly dynamic movement processes.

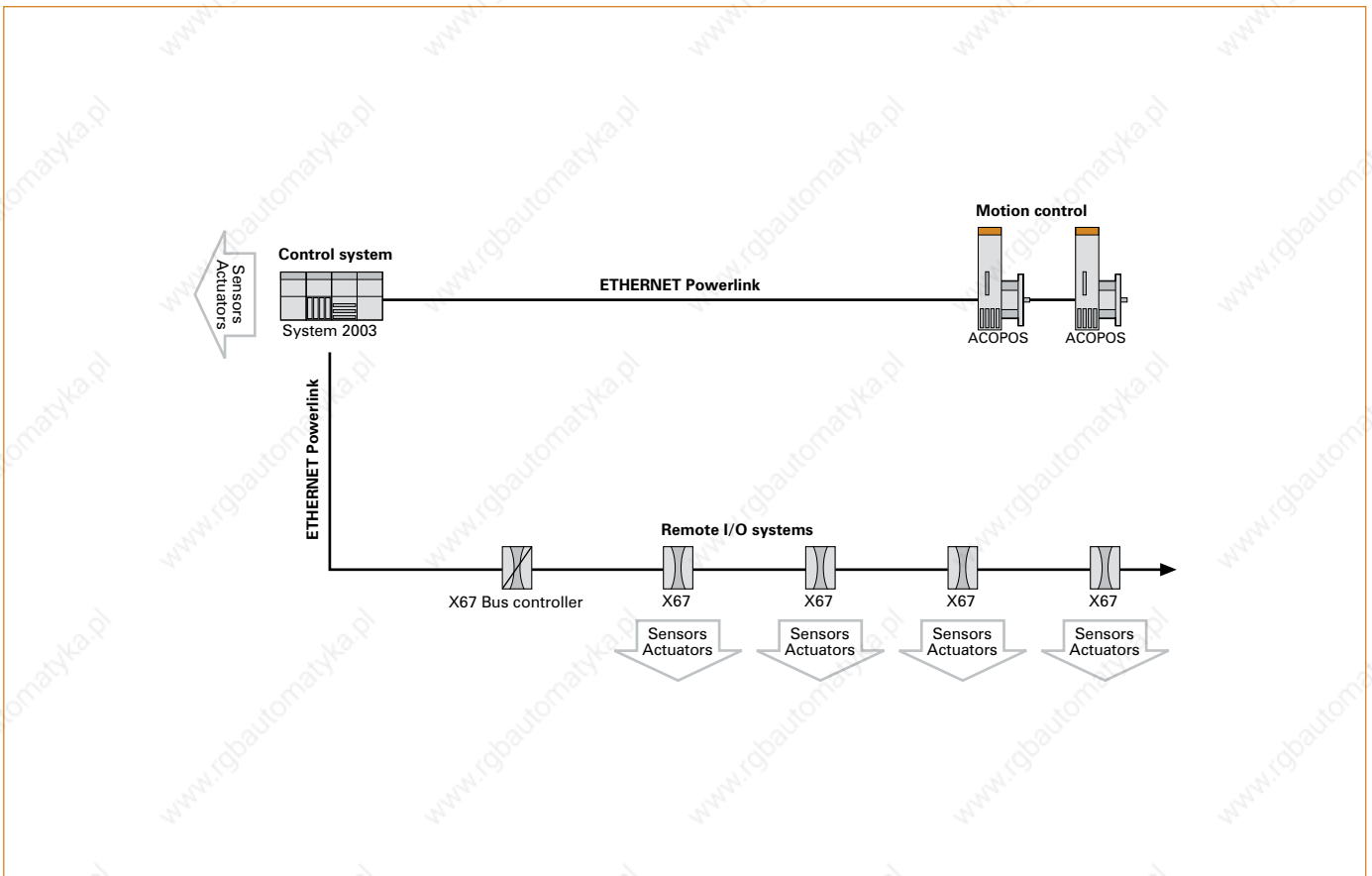

Components and technologies

Control system	System 2003: Compact controllers, remote I/O
Motion control	ACOPOS: Intelligent servo drives Synchronous motors: Dynamic precision drives
Remote input/output systems	X67 System: Remote I/O with IP67 protection
Network and fieldbus modules	ETHERNET Powerlink

Product overview

CPUs



Model number	Short description	
7CP570.60-1 ¹⁾	System 2003 CPU, Celeron 300, 64 MB DRAM, 512 KB SRAM, 24 VDC, 15 W supply, removable application memory: CompactFlash, 1 insert slot for aPCI modules, 1 USB interface, 1 Ethernet interface 100 Base-T	20
7CP476-020.9 ²⁾	System 2003 CPU with expansion, 750 KB SRAM, 1.5 MB FlashPROM, 24VDC, 11.8 W supply, 1 RS232 interface, 1 CAN interface	22
7CP476-010.9	System 2003 CPU with expansion, 750 KB SRAM, 1.5 MB FlashPROM, 24VDC, 12.15 W supply, 1 RS232 interface, 1 CAN interface	24
7CP476.60-1	System 2003 CPU, 750 kB SRAM, 1.5 MB Flash PROM, 24 VDC, 12.5 W supply, 1 RS232, 1 CAN interface, CAN: electrically isolated	26
7CP774.60-1	System 2003 CPU, 100 KB SRAM, 512 KB FlashPROM, 100-240 VAC, 12.6 W supply, 1 RS232 interface, 1 CAN interface,	28
7CP474.60-2	System 2003 CPU, 750 KB SRAM, 512 KB FlashPROM, 24 VDC, 12.6 W supply, 1 RS232 interface, 1 CAN interface	30
7CP770.60-1	System 2003 CPU, 100 KB SRAM, 256 KB FlashPROM, 100-240 VAC, 14 W supply, 1 RS232 interface, 1 CAN interface,	32
7CP470.60-2	System 2003 CPU, 350 KB SRAM, 512 KB FlashPROM, 24 VDC, 14 W supply, 1 RS232 interface, 1 CAN interface	34
7CP430.60-1	System 2003 CPU, 100 KB SRAM, 256 KB FlashPROM, 24 VDC, 7 W supply, 1 RS232 interface, 1 CAN interface, CAN: electrically isolated	36

1) 3IF7xx interface modules can be operated in the insert slot for CP570 aPCI modules (see page 16).

2) 3IF6xx interface modules can be operated in the CP476-020 expansion module (see page 16).

Bus controllers



Model number	Short description	
7EX270.50-1	System 2003 CAN bus controller, 24 VDC, 4 W supply, 1 CAN interface, electrically isolated, network-capable	38
7EX290.50-1	System 2003 X2X Link bus controller, 24 VDC, 3.2 W supply, 1 X2X Link interface, electrically isolated	39
7EX470.50-1	System 2003 CAN bus controller, 24 VDC, 14.5 W supply, 2 CAN interfaces, electrically isolated, network-capable	40
7EX770.50-1	2003 CAN bus controller, 100-240 VAC, 14.5 W supply, 2 CAN interfaces, electrically isolated, network-capable	41
7EX481.50-1	System 2003 ETHERNET Powerlink bus controller, 1 ETHERNET Powerlink interface, 24 VDC, electrically isolated	42
7EX484.50-1	System 2003 ETHERNET Powerlink bus controller, 4 ETHERNET Powerlink interfaces, 24 VDC, electrically isolated	43

Analog interfaces

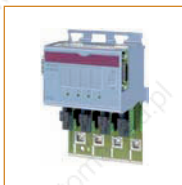

Model number	Short description	
7AF101.7	System 2003 adapter module, 4 slots for screw-in modules	44
7AF104.7	System 2003 high-speed adapter module, 4 slots for screw-in modules	45

I/O module selection table

Function	7AI261.7	7AI294.7	7AI351.70	7AI354.70	7AI774.70	7AM351.70	7AO352.70	7AT324.70	7AT352.70	7AT664.70	7CM211.7	7CM411.70-1	7DI135.70	7DI138.70	7DI140.70	7DI435.7	7DI439.7	7DI439.72	7DI645.7	7DM435.7	7DM438.72	7DM465.7	7DO135.70	7DO138.70	7DO139.70	7DO164.70	7DO435.7	7DO720.7	7DO721.7	7DO722.7	7MM424.70-1	7MM432.70-1	7NC161.7	
Digital input											(8)		(10)	(10)	8	16	16	8	8	8	16							(8)					6	
Digital output											(8)	(2)								8	8	16	(4)	8	(8)	4	(8)	8	4	8				
Analog input	1	4	1	4	4	1					2	3																						
Analog output						1	2				2	3																						
Temperature								4	2	4																								
Event counter											(3)	(2)	(2)	(2)	(2)																			
Incremental encoder											(2)	(1)	(1)		(1)																	2	(1)	
SSI absolute encoder																																		(1)
Period measurement											(1)																							
Gate measurement											(1)																							
Full-bridge strain gauge	1																																	
Potentiometer displacement gauge	1																																	
Comparator output											(1)	(1)																						
Potentiometer voltage		1																																
PWM output																							(4)											
Motor (H) bridges																									(4)								2	
Motor control																									(8)							4		
Page	64	65	66	67	68	70	69	71	72	73	74	76	46	47	48	49	50	51	52	61	62	63	53	54	55	56	57	58	59	60	78	79	106	

Numbers in parentheses represent multiple assignment. Check the specifications in the data sheet for the configuration.

Digital input in the screw-in module



Model number	Short description	
7DI135.70	System 2003 digital input module, 4 inputs 24VDC, sink, incremental encoder operation: 50 kHz, event counter operation: 100 kHz, 1 comparator output	46
7DI138.70	System 2003 digital input module, 10 inputs 24 VDC, sink, 2 inputs for event counter operation, input frequency 20 kHz	47
7DI140.70	System 2003 digital input module, 10 inputs 24 VDC, sink, 2 inputs for event counter operation or direction-dependent position determination	48

Product overview

Digital input in the I/O module



Model number	Short description	
7DI435.7	System 2003 digital input module, 8 inputs 24 VDC, 1 ms, sink/source,	49
7DI439.7	System 2003 digital input module, 16 inputs 24 VDC, 1 ms, sink/source,	50
7DI439.72	System 2003 digital input module, 16 inputs 24 VDC, 1 ms, sink/source, 2 electrically isolated input groups	51
7DI645.7	System 2003 digital input module, 8 inputs 100-240 VAC, 50 ms,	52
7DM435.7	System 2003 digital mixed module, 8 inputs 24 VDC, 1 ms, sink/source, 8 transistor outputs 24 VDC, 0.5 A	61
7DM438.72	System 2003 digital mixed module, 8 inputs 24 VDC, 1 ms, sink/source, 8 transistor outputs 24 VDC, 0.5 A	62
7DM465.7	System 2003 digital mixed module, 16 inputs 24 VDC, 1 ms, sink, 16 transistor outputs 24 VDC, 0.5 A	63
7CM211.7	System 2003 combination module, 8 inputs, 24 VDC, 4 ms, sink, one- or two-channel counter or 2 incremental encoders, 20 kHz	74
7CM411.70-1	System 2003 combination module, 3 inputs, 24 VDC, 50 kHz, sink, one- or two-channel counter, incremental encoder, 2 transistor outputs, 24 VDC, 0.5 A	76

Digital output in the screw-in module



Model number	Short description	
7DO135.70	System 2003 digital output module, 4 FET outputs 12 to 24VDC, 0.1 A, screw-in module	53
7DO138.70	System 2003 digital output module, 8 outputs 24VDC, 0.5 A, short circuit protection, thermal overload protection, screw-in module	54
7DO139.70	System 2003 digital output module, 8 outputs, 12 - 24 VDC, 0.5 A, short circuit protection, thermal overload protection, screw-in module	55
7DO164.70	System 2003 digital output module, 4 FET outputs 48 to 24VDC, 0.05 A, zero cross detection, screw-in module	56

Digital output in the I/O module



Model number	Short description	
7DO435.7	System 2003 digital output module, 8 FET outputs 24 VDC, 2 A. Outputs can be optionally used as inputs.	57
7DO720.7	System 2003 digital output module, 8 relay outputs 240 VAC / 30 VDC, 2 A	58
7DO721.7	System 2003 digital output module, 4 relay outputs 240 VAC / 24 VDC, 4 A	59
7DO722.7	System 2003 digital output module, 8 relay outputs 240 VAC / 24 VDC, 2.5 A	60
7DM435.7	System 2003 digital mixed module, 8 inputs 24 VDC, 1 ms, sink/source, 8 transistor outputs 24 VDC, 0.5 A	61
7DM438.72	System 2003 digital mixed module, 8 inputs 24 VDC, 1 ms, sink/source, 8 transistor outputs 24 VDC, 0.5 A	62
7DM465.7	System 2003 digital mixed module, 16 inputs 24 VDC, 1 ms, sink, 16 transistor outputs 24 VDC, 0.5 A	63
7CM211.7	System 2003 combination module, 8 inputs, 24 VDC, 4 ms, sink, one- or two-channel counter or 2 incremental encoders, 20 kHz	74
7CM411.70-1	System 2003 combination module, 3 inputs, 24 VDC, 50 kHz, sink, one- or two-channel counter, incremental encoder, 2 transistor outputs, 24 VDC, 0.5 A	76
7MM424.70-1	System 2003 motor module, four motor digital output levels, 24 VDC, 3 A at 50°C, max. starting current 10 A (max. 50 ms)	78
7MM432.70-1	System 2003 motor bridge module, two motor (H) bridges, 10 - 30 VDC @ 4 A, peak current up to 8 A (max. 2 s), integrated current regulator	79

Digital input/output combination in the I/O module



Model number	Short description	
7DM435.7	System 2003 digital mixed module, 8 inputs 24 VDC, 1 ms, sink/source, 8 transistor outputs 24 VDC, 0.5 A	61
7DM438.72	System 2003 digital mixed module, 8 inputs 24 VDC, 1 ms, sink/source, 8 transistor outputs 24 VDC, 0.5 A	62
7DM465.7	System 2003 digital mixed module, 16 inputs 24 VDC, 1 ms, sink, 16 transistor outputs 24 VDC, 0.5 A	63
7CM211.7	System 2003 combination module, 8 inputs, 24 VDC, 4 ms, sink, one- or two-channel counter or 2 incremental encoders, 20 kHz	74
7CM411.70-1	System 2003 combination module, 3 inputs, 24 VDC, 50 kHz, sink, one- or two-channel counter, incremental encoder, 2 transistor outputs, 24 VDC, 0.5 A	76

Analog input in the screw-in module



Model number	Short description	
7AI261.7	System 2003 analog input module, 1 input for evaluation of full-bridge strain gauge, 24-bit, screw-in module	64
7AI294.7	System 2003 analog input module, 4 inputs, potentiometer evaluation, 13-bit, screw-in module	65
7AI351.70	System 2003 analog input module, 1 input, +/10 V or 0 to 20 mA, 12-bit + sign, screw-in module	66
7AI354.70	System 2003 analog input module, 4 inputs, +/10 V, 12-bit + sign, screw-in module	67
7AI774.70	System 2003 analog input module, 4 inputs, 0 to 20 mA, 12-bit, screw-in module	68
7AM351.70	System 2003 analog mixed module, 1 input, ± 10 V, 16-bit, 1 output, ± 10 V, 16-bit, screw-in module	70

Analog input in the I/O module



Model number	Short description	
7CM211.7	System 2003 combination module, 8 inputs, 24 VDC, 4 ms, sink, one- or two-channel counter or 2 incremental encoders, 20 kHz	74
7CM411.70-1	System 2003 combination module, 3 inputs, 24 VDC, 50 kHz, sink, one- or two-channel counter, incremental encoder, 2 transistor outputs, 24 VDC, 0.5 A	76

Product overview

Analog output in the screw-in module



Model number	Short description	
7AO352.70	System 2003 analog output module, 2 outputs, ± 10 V or 0 - 20 mA, 12-bit, screw-in module	69
7AM351.70	System 2003 analog mixed module, 1 input, ± 10 V, 16-bit, 1 output, ± 10 V, 16-bit, screw-in module	70

Analog output in the I/O module



Model number	Short description	
7CM211.7	System 2003 combination module, 8 inputs, 24 VDC, 4 ms, sink, one- or two-channel counter or 2 incremental encoders, 20 kHz	74
7CM411.70-1	System 2003 combination module, 3 inputs, 24 VDC, 50 kHz, sink, one- or two-channel counter, incremental encoder, 2 transistor outputs, 24 VDC, 0.5 A	76

Analog input/output combination in the screw-in module



Model number	Short description	
7AM351.70	System 2003 analog mixed module, 1 input, ± 10 V, 16-bit, 1 output, ± 10 V, 16-bit, screw-in module	70

Analog input/output combination in the I/O module



Model number	Short description	
7CM211.7	System 2003 combination module, 8 inputs, 24 VDC, 4 ms, sink, one- or two-channel counter or 2 incremental encoders, 20 kHz	74
7CM411.70-1	System 2003 combination module, 3 inputs, 24 VDC, 50 kHz, sink, one- or two-channel counter, incremental encoder, 2 transistor outputs, 24 VDC, 0.5 A	76

Temperature input in the screw-in module



Model number	Short description	
7AT324.70	System 2003 analog input module, 4 temperature inputs (2-line connection), KTY10 - 50 to +150°C, KTY84 -40 to +300°C, PT100 -200 to +850°C	71
7AT352.70	System 2003 analog input module, 2 inputs, PT100 (3-line connection), -200 to +850°C, screw-in module,	72
7AT664.70	System 2003 analog input module, 4 inputs, thermocouple, -270 to +1,372°C, screw-in module	73

Other functions



Model number	Short description	
7CM211.7	System 2003 combination module, 8 inputs, 24 VDC, 4 ms, sink, one- or two-channel counter or 2 incremental encoders, 20 kHz	74
7CM411.70-1	System 2003 combination module, 3 inputs, 24 VDC, 50 kHz, sink, one- or two-channel counter, incremental encoder, 2 transistor outputs, 24 VDC, 0.5 A	76
7MM424.70-1	System 2003 motor module, four motor digital output levels, 24 VDC, 3 A at 50°C, max. starting current 10 A (max. 50 ms)	78
7MM432.70-1	System 2003 motor bridge module, two motor (H) bridges, 10 - 30 VDC @ 4 A, peak current up to 8 A (max. 2 s), integrated current regulator	79

Product overview

Communication



Model number	Short description	
3IF613.9	System 2005 interface module, 3 RS232 interfaces, insert for CPU and IF modules	83
3IF621.9	System 2005 interface module, 1 RS485/RS422 interface, 1 CAN interface, both electrically isolated and network-capable, CPU and IF module insert	84
3IF622.9	System 2005 interface module, 1 RS232 interface, 2 RS485/RS422 interfaces: electrically isolated, network-capable, CPU and IF module insert	85
3IF661.9	System 2005 interface module, 1 RS485 interface, electrically isolated and network-capable, transfer protocol: Profibus DP, CPU and IF module insert	86
3IF671.9	System 2005 interface module, 1 RS232 interface, 1 RS485/RS422 interface, electrically isolated, network-capable, 1 CAN interface, electrically isolated, network-capable, insert for CPU and IF modules	87
3IF672.9	System 2005 interface module, 1 RS232 interface, 2 CAN interfaces, CAN: electrically isolated, network-capable, CPU and IF module insert	88
3IF681.86	System 2005 interface module, 1 RS232 interface, 1 Ethernet interface, with 10BASE-T twisted pair RJ45 socket	89
3IF686.9	System 2005 interface module, 1 ETHERNET Powerlink interface, managing or controlled node, electrically isolated	90

3IF6xx interface modules can be operated in the CP476-020 expansion module.

Communication in an aPCI module



Model number	Short description	
3IF722.9	aPCI interface module, 1 CAN interface, max. 500 kBit/s, object buffers in both send and receive directions, network-capable, electrically isolated, 1 RS485/RS422 interface, 1 RS485 interface to terminal block	91
3IF761.9	aPCI interface module, 1 Profibus DP interface, electrically isolated and network-capable, 1 RS232 interface	92
3IF762.9	aPCI interface module, 1 Profibus DP interface, electrically isolated and network-capable, 1 RS485/422 interface, electrically isolated and network-capable	93
3IF766.9	aPCI interface module, 1 Profibus DP master interface, electrically isolated and network-capable, max. 12 MBit/s, max. 3.5 KB input data and max. 3.5 KB output data, RS232 configuration interface	94
3IF771.9	aPCI interface module, 1 CAN interface, max. 500 kBit/s, CAN bus: electrically isolated, network-capable, object buffers in send and receive directions	95
3IF772.9	aPCI interface module, 1 RS232 interface, 2 CAN interface, max. 500 kBit/s, CAN bus: electrically isolated, network-capable, object buffers in send and receive directions	96
3IF779.9	aPCI interface module, 1 X2X Link master interface, electrically isolated, 1 CAN interface, max. 500 kBit/s, object buffers in both send and receive directions, network-capable, electrically isolated, 1 RS485/RS422 interface	97
3IF781.9	aPCI interface module, 1 Ethernet interface 10/100 Base-T	98
3IF782.9	aPCI interface module, 1 ETHERNET Powerlink interface, managing or controlled node, 1 RS485 interface to terminal block	99
3IF786.9	aPCI interface module, 1 ETHERNET Powerlink interface, managing or controlled node, 1 RS232 interface	100
3IF787.9	aPCI interface module, 1 ETHERNET Powerlink interface, managing or controlled node, 1 CAN interface, max. 500 kBit/s, object buffers in send and receive directions, network-capable, electrically isolated	101
3IF789.9	aPCI interface module 1 ETHERNET Powerlink interface, managing or controlled node 1 X2X Link master interface, electrically isolated	102
3IF791.9	aPCI interface module, 1 X2X Link master interface, electrically isolated	103
3IF792.9	aPCI interface module, 2 X2X Link master interfaces, electrically isolated, 1 RS232 interface	104
3IF797.9-1	aPCI interface module, 1 X2X Link master interface, electrically isolated, 1 CAN interface, max. 500 kBit/s, object buffers in both send and receive directions, network-capable, electrically isolated, 1 RS232 interface	105

3IF7xx interface modules can be operated in the insert slot for CP570 aPCI modules.

Communication in the screw-in module



Model number	Short description	
7IF311.7	System 2003 interface module, 1 RS232 interface, screw-in module	80
7IF321.7	System 2003 interface module, 1 RS485/RS422 interface, electrically isolated, network-capable, screw-in module	81
7IF361.70-1	System 2003 interface module, 1 RS485 interface, electrically isolated and network-capable, transfer protocol: Profibus DP, screw-in module	82

Further communication possibilities in the System 2003 are offered by the CPUs CP476-020 and CP570. They can operate the System 2005 interface modules.

Counting and positioning in the screw-in module



Model number	Short description	
7DI135.70	System 2003 digital input module, 4 inputs 24VDC, sink, incremental encoder operation: 50 kHz, event counter operation: 100 kHz, 1 comparator output	46
7DI138.70	System 2003 digital input module, 10 inputs 24 VDC, sink, 2 inputs for event counter operation, input frequency 20 kHz	47
7DI140.70	System 2003 digital input module, 10 inputs 24 VDC, sink, 2 inputs for event counter operation or direction-dependent position determination	48
7NC161.7	System 2003 encoder module, input frequency 100 kHz, incremental or absolute, 32-bit, encoder supply 5 VDC or 24 VDC, screw-in module	106

Counting and positioning in the I/O module



Model number	Short description	
7CM211.7	System 2003 combination module, 8 inputs, 24 VDC, 4 ms, sink, one- or two-channel counter or 2 incremental encoders, 20 kHz	74
7CM411.70-1	System 2003 combination module, 3 inputs, 24 VDC, 50 kHz, sink, one- or two-channel counter, incremental encoder, 2 transistor outputs, 24 VDC, 0.5 A	76

Product overview

Module racks



Model number	Short description	
7BP702.0	System 2003 module rack for 2 modules	107
7BP703.0	System 2003 module rack for 3 modules	107
7BP704.0	System 2003 module rack for 4 modules	107
7BP705.0	System 2003 module rack for 5 modules	107
7BP706.0	System 2003 module rack for 6 modules	107
7BP707.0	System 2003 module rack for 7 modules	107
7BP708.0	System 2003 module rack for 8 modules	107
7BP709.0	System 2003 module rack for 9 modules	107
7BP710.0	System 2003 module rack for 10 modules	107
7BP701.1	System 2003 module rack for 1 module, incl. right side section	107
7BP702.1	System 2003 module rack for 2 modules, incl. right side section	107

Application memory

Model number	Short description	
7ME770.5	System 2003 configuration memory for CAN bus controller	108

Accessories

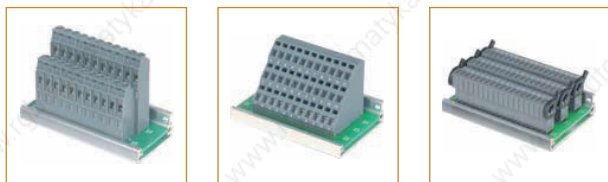

Model number	Short description	
7AC010.9	System 2003 bus cover, 5 pcs.	108
7AC011.9	System 2003 stress relief attachment, 5 pcs., incl. mounting material	108
7AC020.9	System 2003 bus cover, 1 pc.	108
7AC570.1	System 2003 accessories - aPCI slot cover	109
7TB722.9	System 2003 terminal block, 22-pin, screw clamps	110
7TB722.91	System 2003 terminal block, 22-pin, cage clamps	110
7TB733.9	System 2003 terminal block, 33-pin, screw clamps	110
7TB733.91	System 2003 terminal block, 33-pin, cage clamps	110
7TB736.9	System 2003 terminal block, 36-pin, screw clamps	111
7TB736.91	System 2003 terminal block, 36-pin, cage clamps	111
7TB754.9	System 2003 terminal block, 54-pin, screw clamps	111
7TB754.91	System 2003 terminal block, 54-pin, cage clamps	111
7TB772.91	System 2003 terminal block, 72-pin, cage clamps	112



CPU CP570

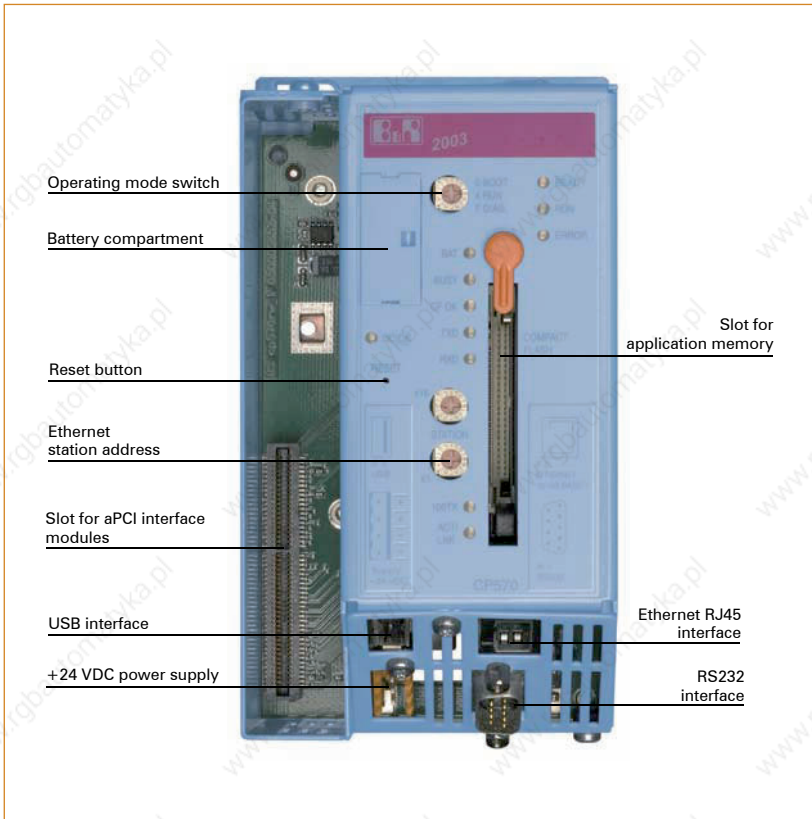

The CP570 is an x86-based, high-performance CPU for the System 2003. This CPU is especially useful for applications where shorter cycle times are required, very large amounts of data must be processed, or when floating point calculations are necessary.

USB and 10/100 MBit/s Ethernet are standard. CompactFlash cards are used for storing programs and data.

- Powerful x86-compatible CPU with an additional I/O processor
- Ethernet 10/100 MBit/s and USB
- CompactFlash as removable application memory
- 1 slot for aPCI interface modules



Short description	7CP570.60-1
System module	CPU
Processor	Celeron 300
Interfaces	1 x RS232, 1 x Ethernet, 1 x USB
Controller	7CP570.60-1
Fastest task class cycle time	500 μ s
Typical instruction cycle time	0.018 μ s
L1 cache for data and program code	2 x 16 KB
L2 cache	128 KB
Standard memory	
RAM	64 MB SDRAM
User RAM	496 KB SRAM
Remanent variables	32 KB
FPU	Yes
Integrated I/O processor	Processes I/O data points in the background
Data buffering	
Lithium battery	At least 3 years
Battery monitoring	Yes
CompactFlash slot	1
Real-time clock	Nonvolatile memory, resolution 1 second
Reset button	Yes
Insert slots	1 for IF7xx aPCI interface modules
I/O bus interface	9-pin DSUB socket

Interfaces		7CP570.60-1
Interface IF1		RS232, 9-pin DSUB plug, 115.2 kBit/s
Interface IF2		Ethernet, shielded RJ45 socket, 10/100 MBit/sec, max. 100 m between two stations (segment length)
Interface IF3		USB 1.1
Power supply		7CP570.60-1
Input voltage		24 VDC
Voltage range		20.4 VDC to 30 VDC
Power consumption		30 W
Output power		
For I/O and aPCI modules		
Horizontal installation		15.0 W at 50°C and 10.0 W at 60°C
Vertical installation		15.0 W at 40°C and 10.0 W at 50°C
General information		7CP570.60-1
Status indicators		CPU function, battery, CompactFlash, RS232, Ethernet
Diagnostics		
CPU function		Yes, with status LED
Battery		Yes, with status LED and software status
CompactFlash		Yes, with status LED
RS232		Yes, with status LED
Ethernet		Yes, with status LED
Operation on module slot		1
Logical module slots		Max. 16
Analog module slots		Max. 8
Possible module addresses for analog modules		1 - 16, for description see section "Module slot rules" 123
Visual Components-capable		Yes
ACOPOS-capable		Yes
Electrical isolation		
PLC - IF1/IF3		No
PLC - IF2		Yes
IF1/IF3 - IF2		Yes
IF1 - IF3		No
Certification		CE, C-UL-US (in development), GOST-R
Mechanical characteristics		7CP570.60-1
Module width		System 2003 single-width
Protection type		IP20
Operating temperature		
Horizontal installation		0°C to +60°C
Vertical installation		0°C to +50°C
Storage temperature		-25°C to +60°C
Relative humidity		5 to 95%, non-condensing
Comment		Order application memory (CompactFlash) separately; backup battery included in delivery

Required accessories	
5CFCRD.0064-03	CompactFlash 64 MB ATA/IDE SiliconSystems
5CFCRD.0128-03	CompactFlash 128 MB ATA/IDE SiliconSystems
5CFCRD.0256-03	CompactFlash 256 MB ATA/IDE SiliconSystems
5CFCRD.0512-03	CompactFlash 512 MB ATA/IDE SiliconSystems
5CFCRD.1024-03	CompactFlash 1024 MB ATA/IDE SiliconSystems
5CFCRD.2048-03	CompactFlash 2048 MB ATA/IDE SiliconSystems
5CFCRD.4096-03	CompactFlash 4096 MB ATA/IDE SiliconSystems
5CFCRD.8192-03	CompactFlash 8192 MB ATA/IDE SiliconSystems

Optional accessories	
4A0006.00-000	Lithium battery, 3 V / 950 mAh, button cell
0AC201.9	Lithium batteries, 5 pcs., 3 V / 950 mAh, button cell
0G0001.00-090	Cable PC <-> PLC/PW, RS232, online cable
7AC570.1	System 2003 accessories - aPCI slot cover 109
3IF7xx	Communication with ETHERNET Powerlink, X2X Link, CAN bus, Profibus DP, RS232, RS422, RS485 16

CPU CP476-020

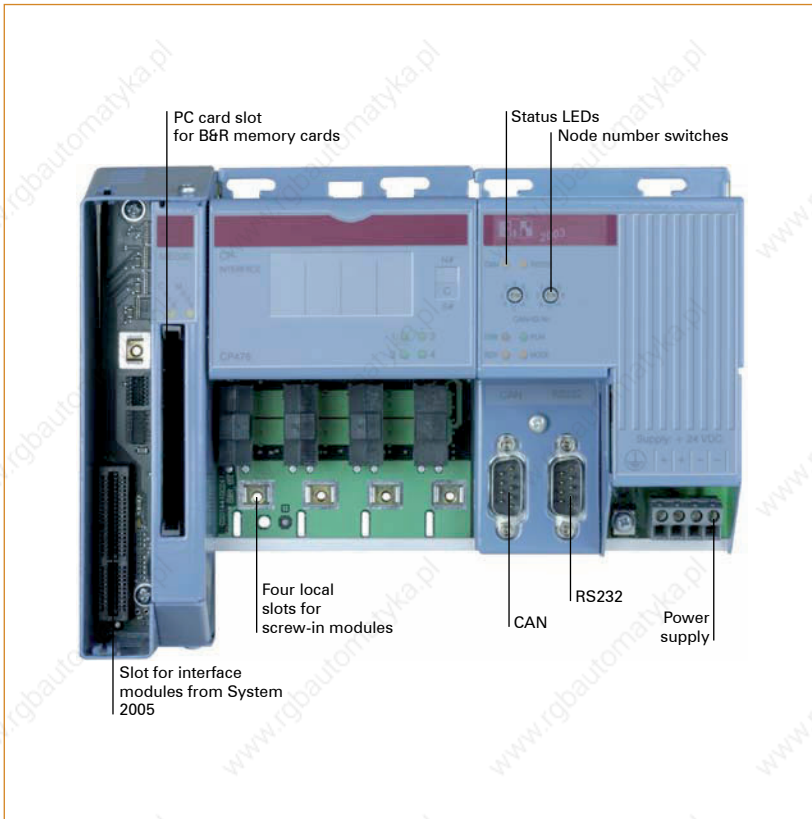

The CP476-020 CPU represents the upper performance range of the System 2003. It has the same performance specs as the CP476. It is additionally equipped with expansion modules for PC cards and System 2005 interface modules. PC cards are used to update software or as an external recipe memory.

The CP476-020 CPU has four local slots integrated. Analog or digital screw-in modules for I/O signals can be operated on these slots. The CP476-020 is equipped with a time processor unit (TPU) for carrying out high-speed signal processing in the microsecond range. Digital screw-in modules with TPU functions are available for this purpose.

The CPU is equipped with an RS232 and a CAN interface. Up to four screw-in modules can be used on the local slots of the CPU.

The RS232 interface is primarily intended for programming the CPU. It can also be used as a general interface for connecting visualization units, printers, or barcode readers.

The CAN fieldbus interface is used for communicating with other control systems and for remote expansion of inputs and outputs with System 2003 components and a CAN bus controller, e.g. EX470.

- 750 KB User SRAM
- 1.5 MB User FlashPROM
- Additional I/O processor
- 2 node number switches for CAN
- Same performance specs as the CP476
- Expansion module for PC cards
- Expansion module for System 2005 interface modules (IF6xx)



Short description	7CP476-020.9
System module	CPU
Interfaces	1 x RS232, 1 x CAN bus
Controller	7CP476-020.9
Fastest task class cycle time	1 ms
Typical instruction cycle time	0.5 µs
Additional I/O processor	Handles I/O data points
Standard memory	
User RAM	750 KB SRAM
System PROM	512 KB FlashPROM
User PROM	1.5 MB FlashPROM
Data buffering	
Lithium battery	Typ. 3 years
Battery monitoring	Yes
Hardware watchdog	Yes
Voltage monitoring	Internal supply monitored for overvoltage and undervoltage
Real-time clock	Nonvolatile memory, resolution 1 s
I/O bus interface (right side)	9-pin DSUB socket
System bus for expansions (left side)	Expansion module for System 2005 interface modules (IF6xx) and PC cards
Slots for screw-in modules	4
Suitable for IF modules	1 - 3

Interfaces		7CP476-020.9
Interface IF1		RS232, 9-pin DSUB plug, 57.6 kBit/s
Interface IF2		CAN bus, 9-pin DSUB plug, 500 kBit/s
Power supply		7CP476-020.9
Input voltage		24 VDC
Voltage range		18 VDC to 30 VDC
Power consumption		20.0 W
Output power for I/O ports		11.8 W ¹⁾ without PC card
1) Integrated power supply on pin 4 of the RS232 interface for simple Panelware controllers, e.g. P126		
General information		7CP476-020.9
Status indicators		CPU function, RS232, CAN bus, operating state per screw-in module, PC card
Diagnostics		
CPU function	Yes, with status LED	
RS232	Yes, with status LED	
CAN	Yes, with status LED	
Operating state of screw-in modules	Yes, with status LED	
PC card	Yes, with status LED	
Operation on module slot		1 + 2
Logical module slots		Max. 16
Analog module slots		Max. 4
Possible module addresses for analog modules		1 - 8, for description see section "Module slot rules" 123
Visual Components-capable		No
ACOPOS-capable		Yes
Electrical isolation		
PLC - IF1		No
PLC - IF2		Yes
IF1 - IF2		Yes
Certification		CE, C-UL-US, GOST-R
Mechanical characteristics		7CP476-020.9
Module width		System 2003 double-width + 37 mm
Protection type		IP20
Operating temperature		
Horizontal installation		0°C to +60°C
Vertical installation		0°C to +50°C
Storage temperature		-25°C to +60°C
Relative humidity		5 to 95%, non-condensing
Comment		Backup battery included in delivery Integrated time processor unit (TPU) for high-speed signal processing in the microsecond range on integrated slots for screw-in modules

Optional accessories		
4A0006.00-000	Lithium battery, 3 V / 950 mAh, button cell	
0AC201.9	Lithium batteries, 5 pcs., 3 V / 950 mAh, button cell	
0G0001.00-090	Cable PC <-> PLC/PW, RS232, online cable	
7AC911.9	Bus connector, CAN	
0AC912.9	Bus adapter, CAN, 1 CAN interface	
0AC913.92	Bus adapter, CAN, 2 CAN interfaces, including 30 cm connection cable (DSUB connector)	
0MC111.9	PC card, 2 MB FlashPROM	
0MC112.9	PC card, 4 MB FlashPROM	
0MC211.9	PC card, 2 MB SRAM	
7AC570.1	System 2003 accessories - aPCI slot cover	109
3IF6xx	Communication with ETHERNET Powerlink, CAN, Profibus DP, RS232, RS422, RS485	16

CPU CP476-010

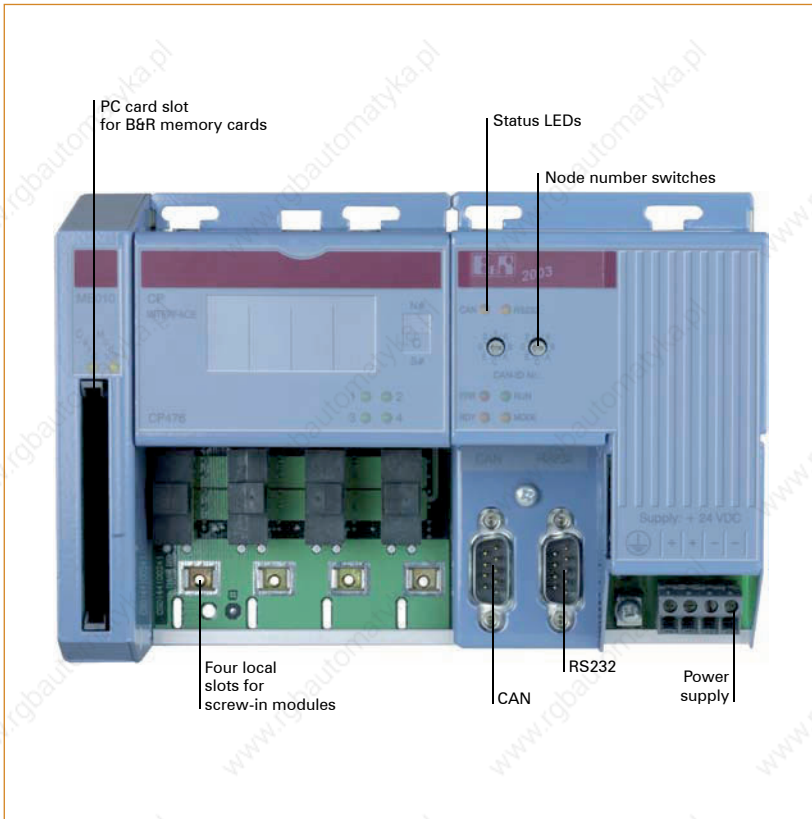

The CP476-010 CPU represents the upper performance range of the System 2003. It has the same performance specs as the CP476. It is, however, equipped with an expansion module for PC cards. PC cards are used to update software or as an external recipe memory.

The CP476-010 CPU has four local slots integrated. Analog or digital screw-in modules for I/O signals can be operated on these slots. The CP476-010 is equipped with a time processor unit (TPU) for carrying out high-speed signal processing in the microsecond range. Digital screw-in modules with TPU functions are available for carrying this out.

The CPU is equipped with an RS232 and a CAN interface. Up to four screw-in modules can be used on the local slots of the CPU.

The RS232 interface is primarily intended for programming the CPU. It can also be used as a general interface for connecting visualization units, printers, or barcode readers.

The CAN fieldbus interface is used for communicating with other control systems and for remote expansion of inputs and outputs with System 2003 components and a CAN bus controller, e.g. EX470.

Memory capacity was increased to meet the increasing requirements of the applications.

- 750 KB User SRAM
- 1.5 MB User FlashPROM
- Additional I/O processor
- 2 node number switches for CAN
- Same performance specs as the CP476
- Expansion module for PC cards



Short description	7CP476-010.9
System module	CPU
Interfaces	1 x RS232, 1 x CAN bus
Controller	7CP476-010.9
Fastest task class cycle time	1 ms
Typical instruction cycle time	0.5 μ s
Additional I/O processor	Handles I/O data points
Standard memory	
User RAM	750 KB SRAM
System PROM	512 KB FlashPROM
User PROM	1.5 MB FlashPROM
Data buffering	
Lithium battery	Typ. 3 years
Battery monitoring	Yes
Hardware watchdog	Yes
Voltage monitoring	Internal supply monitored for overvoltage and undervoltage
Real-time clock	Nonvolatile memory, resolution 1 second
I/O bus interface (right side)	9-pin DSUB socket
System bus for expansions (left side)	Expansion module for PC cards
Slots for screw-in modules	4
Suitable for IF modules	1 - 3

Interfaces		7CP476-010.9
Interface IF1		
Type	RS232	
Design	9-pin DSUB plug	
Maximum transfer rate	57.6 kBit/s	
Interface IF2		
Type	CAN bus	
Design	9-pin DSUB plug	
Maximum transfer rate	500 kBit/s	
Power supply		7CP476-010.9
Input voltage	24 VDC	
Voltage range	18 VDC to 30 VDC	
Power consumption	20.0 W	
Output power for I/O ports	12.15 W ¹⁾ without PC card	
1) Integrated power supply on pin 4 of the RS232 interface for simple Panelware controllers, e.g. P126		
General information		7CP476-010.9
Status indicators	CPU function, RS232, CAN bus, operating state per screw-in module, PC card	
Diagnostics		
CPU function	Yes, with status LED	
RS232	Yes, with status LED	
CAN	Yes, with status LED	
Operating state of screw-in modules	Yes, with status LED	
PC card	Yes, with status LED	
Operation on module slot	1 + 2	
Logical module slots	Max. 16	
Analog module slots	Max. 4	
Possible module addresses for analog modules	1 - 8, for description see section "Module slot rules"	123
Visual Components-capable	No	
ACOPOS-capable	Yes	
Electrical isolation		
PLC - IF1	No	
PLC - IF2	Yes	
IF1 - IF2	Yes	
Certification	CE, C-UL-US, GOST-R	
Mechanical characteristics		7CP476-010.9
Module width	System 2003 double-width + 20 mm	
Protection type	IP20	
Operating temperature		
Horizontal installation	0°C to +60°C	
Vertical installation	0°C to +50°C	
Storage temperature	-25°C to +60°C	
Relative humidity	5 to 95%, non-condensing	
Comment	Backup battery included in delivery Integrated time processor unit (TPU) for high-speed signal processing in the microsecond range on integrated slots for screw-in modules	

Optional accessories	
4A0006.00-000	Lithium battery, 3 V / 950 mAh, button cell
0AC201.9	Lithium batteries, 5 pcs., 3 V / 950 mAh, button cell
0G0001.00-090	Cable PC <-> PLC/PW, RS232, online cable
7AC911.9	Bus connector, CAN
0AC912.9	Bus adapter, CAN, 1 CAN interface
0AC913.92	Bus adapter, CAN, 2 CAN interfaces, including 30 cm connection cable (DSUB connector)
0MC111.9	PC card, 2 MB FlashPROM
0MC112.9	PC card, 4 MB FlashPROM
0MC211.9	PC card, 2 MB SRAM

CPU CP476



The CP476 CPU represents the upper performance range of the System 2003. Increased clock frequency and the integration of a separate I/O processor results in a 50% increase in performance while doubling the speed of analog value processing on local screw-in modules compared to the CP474.

The CP476 CPU has four integrated local slots. Analog or digital screw-in modules for I/O signals can be operated on these slots. The CP476 is equipped with a time processor unit (TPU) for carrying out high-speed signal processing in the microsecond range. Digital screw-in modules with TPU functions are available for carrying this out.

The CPU is equipped with an RS232 and a CAN interface. Up to four screw-in modules can be used on the local slots of the CPU.

The RS232 interface is primarily intended for programming the CPU. It can also be used as a general interface for connecting visualization units, printers, or barcode readers.

The CAN fieldbus interface is used for communicating with other control systems and for remote expansion of inputs and outputs with System 2003 components and a CAN bus controller, e.g. EX470.

Memory capacity was increased to meet the increasing requirements of the applications.

- 750 KB User SRAM
- 1.5 MB User FlashPROM
- Additional I/O processor
- 2 node number switches for CAN



Short description	7CP476.60-1
System module	CPU
Interfaces	1 x RS232, 1 x CAN bus
Controller	7CP476.60-1
Fastest task class cycle time	1 ms
Typical instruction cycle time	0.5 μ s
Additional I/O processor	Handles I/O data points
Standard memory	
User RAM	750 KB SRAM
System PROM	512 KB FlashPROM
User PROM	1.5 MB FlashPROM
Data buffering	
Lithium battery	Typ. 3 years
Battery monitoring	Yes
Hardware watchdog	Yes
Voltage monitoring	Internal supply monitored for overvoltage and undervoltage
Real-time clock	Nonvolatile memory, resolution 1 second
I/O bus interface	9-pin DSUB socket
Slots for screw-in modules	4
Suitable for IF modules	1 - 3

Interfaces		7CP476.60-1
Interface IF1		
Type	RS232	
Design	9-pin DSUB plug	
Maximum transfer rate	57.6 kBit/s	
Interface IF2		
Type	CAN bus	
Design	9-pin DSUB plug	
Maximum transfer rate	500 kBit/s	
Power supply		7CP476.60-1
Input voltage	24 VDC	
Voltage range	18 VDC to 30 VDC	
Power consumption	20.0 W	
Output power for I/O ports	12.5 W ¹⁾	
1) Integrated power supply on pin 4 of the RS232 interface for simple Panelware controllers, e.g. P126		
General information		7CP476.60-1
Status indicators	CPU function, RS232, CAN bus, operating state per screw-in module	
Diagnostics		
CPU function	Yes, with status LED	
RS232	Yes, with status LED	
CAN	Yes, with status LED	
Operating state of screw-in modules	Yes, with status LED	
Operation on module slot	1 + 2	
Logical module slots	Max. 16	
Analog module slots	Max. 4	
Possible module addresses for analog modules	1 - 8, for description see section "Module slot rules" 123	
Visual Components-capable	No	
ACOPOS-capable	Yes	
Electrical isolation		
PLC - IF1	No	
PLC - IF2	Yes	
IF1 - IF2	Yes	
Certification	CE, C-UL-US, GOST-R	
Mechanical characteristics		7CP476.60-1
Dimensions	System 2003 double-width	
Protection type	IP20	
Operating temperature		
Horizontal installation	0°C to +60°C	
Vertical installation	0°C to +50°C	
Storage temperature	-25°C to +60°C	
Relative humidity	5 to 95%, non-condensing	
Comment	Backup battery included in delivery Integrated time processor unit (TPU) for high-speed signal processing in the microsecond range on integrated slots for screw-in modules	

Optional accessories	
4A0006.00-000	Lithium battery, 3 V / 950 mAh, button cell
0AC201.9	Lithium batteries, 5 pcs., 3 V / 950 mAh, button cell
0G0001.00-090	Cable PC <-> PLC/PW, RS232, online cable
7AC911.9	Bus connector, CAN
0AC912.9	Bus adapter, CAN, 1 CAN interface
0AC913.92	Bus adapter, CAN, 2 CAN interfaces, including 30 cm connection cable (DSUB connector)

CPU CP774



The CP774 CPU has four local slots integrated. Analog or digital screw-in modules for I/O signals can be operated on these slots. The CP774 is equipped with a time processor unit (TPU) for carrying out high-speed signal processing in the microsecond range. Digital screw-in modules with TPU functions are available for carrying this out.

The CPU is equipped with an RS232 and a CAN interface. Up to four screw-in modules can be used on the local slots of the CPU.

The RS232 interface is primarily intended for programming the CPU. It can also be used as a general interface for connecting visualization units, printers, or barcode readers.

The CAN fieldbus interface is used for communicating with other control systems and for remote expansion of inputs and outputs with System 2003 components and a CAN bus controller, e.g. EX470.

Data buffering and nonvolatile operation of the real-time clock are guaranteed by the lithium battery provided.

The CP774 CPU is based on the CP474 with a power supply of 100 to 240 VAC.

- 100 KB User SRAM
- 512 KB User FlashPROM
- RS232 and CAN interface
- 4 local slots for screw-in modules
- Operation of 8 I/O modules
- 100 - 240 VAC supply voltage



Short description	7CP774.60-1
System module	CPU
Interfaces	1 x RS232, 1 x CAN bus
Controller	7CP774.60-1
Fastest task class cycle time	1 ms
Typical instruction cycle time	0.8 μ s
Standard memory	
User RAM	100 KB SRAM
System PROM	512 KB FlashPROM
User PROM	512 KB FlashPROM
Data buffering	
Lithium battery	Typ. 3 years
Battery monitoring	Yes
Hardware watchdog	Yes
Voltage monitoring	Internal supply monitored for overvoltage and undervoltage
Real-time clock	Nonvolatile memory, resolution 1 second
I/O bus interface	9-pin DSUB socket
Slots for screw-in modules	4
Suitable for IF modules	1 - 3

Interfaces		7CP774.60-1
Interface IF1		
Type	RS232	
Design	9-pin DSUB plug	
Maximum transfer rate	57.6 kBit/s	
Interface IF2		
Type	CAN bus	
Design	9-pin DSUB plug	
Maximum transfer rate	500 kBit/s	
Power supply		7CP774.60-1
Input voltage	100 - 240 VAC	
Voltage range	85 VAC to 264 VAC	
Input voltage frequency	47 to 63 Hz	
Power consumption	20.0 W	
Output power for I/O ports	12.6 W ¹⁾	
1) Integrated power supply on pin 4 of the RS232 interface for simple Panelware controllers, e.g. P126		
General information		7CP774.60-1
Status indicators	CPU function, RS232, CAN bus, operating state per screw-in module	
Diagnostics		
CPU function	Yes, with status LED	
RS232	Yes, with status LED	
CAN	Yes, with status LED	
Operating state of screw-in modules	Yes, with status LED	
Operation on module slot	1 + 2	
Logical module slots	Max. 12	
Analog module slots	Max. 4	
Possible module addresses for analog modules	1 - 8, for description see section "Module slot rules"  123	
Visual Components-capable	No	
ACOPOS-capable	Yes	
Electrical isolation		
PLC - IF1	No	
PLC - IF2	Yes	
IF1 - IF2	Yes	
Certification	CE, C-UL-US, GOST-R	
Mechanical characteristics		7CP774.60-1
Dimensions	System 2003 double-width	
Protection type	IP20	
Operating temperature		
Horizontal installation	0°C to +60°C	
Vertical installation	0°C to +50°C	
Storage temperature	-25°C to +60°C	
Relative humidity	5 to 95%, non-condensing	
Comment	Backup battery included in delivery Integrated time processor unit (TPU) for high-speed signal processing in the microsecond range on integrated slots for screw-in modules	

Optional accessories	
4A0006.00-000	Lithium battery, 3 V / 950 mAh, button cell
0AC201.9	Lithium batteries, 5 pcs., 3 V / 950 mAh, button cell
0G0001.00-090	Cable PC <-> PLC/PW, RS232, online cable
7AC911.9	Bus connector, CAN
0AC912.9	Bus adapter, CAN, 1 CAN interface
0AC913.92	Bus adapter, CAN, 2 CAN interfaces, including 30 cm connection cable (DSUB connector)

CPU CP474



The CP474 CPU has four local slots integrated. Analog or digital screw-in modules for I/O signals can be operated on these slots. The CP474 is equipped with a time processor unit (TPU) for carrying out high-speed signal processing in the microsecond range. Digital screw-in modules with TPU functions are available for carrying this out.

The CPU is equipped with an RS232 and a CAN interface. Up to four screw-in modules can be used on the local slots of the CPU.

The RS232 interface is primarily intended for programming the CPU. It can also be used as a general interface for connecting visualization units, printers, or barcode readers.

The CAN fieldbus interface is used for communicating with other control systems and for remote expansion of inputs and outputs with System 2003 components and a CAN bus controller, e.g. EX470.

Data buffering and nonvolatile operation of the real-time clock are guaranteed by the lithium battery provided.

- 750 KB User SRAM
- 512 KB User FlashPROM
- RS232 and CAN interface
- 4 local slots for screw-in modules
- Operation of 8 I/O modules



Short description	7CP474.60-2
System module	CPU
Interfaces	1 x RS232, 1 x CAN bus
Controller	7CP474.60-2
Fastest task class cycle time	1 ms
Typical instruction cycle time	0.8 μ s
Standard memory	
User RAM	750 KB SRAM
System PROM	512 KB FlashPROM
User PROM	512 KB FlashPROM
Data buffering	
Lithium battery	Typ. 3 years
Battery monitoring	Yes
Hardware watchdog	Yes
Voltage monitoring	Internal supply monitored for overvoltage and undervoltage
Real-time clock	Nonvolatile memory, resolution 1 second
I/O bus interface	9-pin DSUB socket
Slots for screw-in modules	4
Suitable for IF modules	1 - 3

Interfaces		7CP474.60-2
Interface IF1		
Type	RS232	
Design	9-pin DSUB plug	
Maximum transfer rate	57.6 kBit/s	
Interface IF2		
Type	CAN bus	
Design	9-pin DSUB plug	
Maximum transfer rate	500 kBit/s	
Power supply		7CP474.60-2
Input voltage	24 VDC	
Voltage range	18 VDC to 30 VDC	
Power consumption	20.0 W	
Output power for I/O ports	12.6 W ¹⁾	
1) Integrated power supply on pin 4 of the RS232 interface for simple Panelware controllers, e.g. P126		
General information		7CP474.60-2
Status indicators	CPU function, RS232, CAN bus, operating state per screw-in module	
Diagnostics		
CPU function	Yes, with status LED	
RS232	Yes, with status LED	
CAN	Yes, with status LED	
Operating state of screw-in modules	Yes, with status LED	
Operation on module slot	1 + 2	
Logical module slots	Max. 12	
Analog module slots	Max. 4	
Possible module addresses for analog modules	1 - 8, for description see section "Module slot rules" 123	
Visual Components-capable	No	
ACOPOS-capable	Yes	
Electrical isolation		
PLC - IF1	No	
PLC - IF2	Yes	
IF1 - IF2	Yes	
Certification	CE, C-UL-US, GOST-R	
Mechanical characteristics		7CP474.60-2
Dimensions	System 2003 double-width	
Protection type	IP20	
Operating temperature		
Horizontal installation	0°C to +60°C	
Vertical installation	0°C to +50°C	
Storage temperature	-25°C to +60°C	
Relative humidity	5 to 95%, non-condensing	
Comment	Backup battery included in delivery Integrated time processor unit (TPU) for high-speed signal processing in the microsecond range on integrated slots for screw-in modules	

Optional accessories	
4A0006.00-000	Lithium battery, 3 V / 950 mAh, button cell
0AC201.9	Lithium batteries, 5 pcs., 3 V / 950 mAh, button cell
0G0001.00-090	Cable PC <-> PLC/PW, RS232, online cable
7AC911.9	Bus connector, CAN
0AC912.9	Bus adapter, CAN, 1 CAN interface
0AC913.92	Bus adapter, CAN, 2 CAN interfaces, including 30 cm connection cable (DSUB connector)

CPU CP770

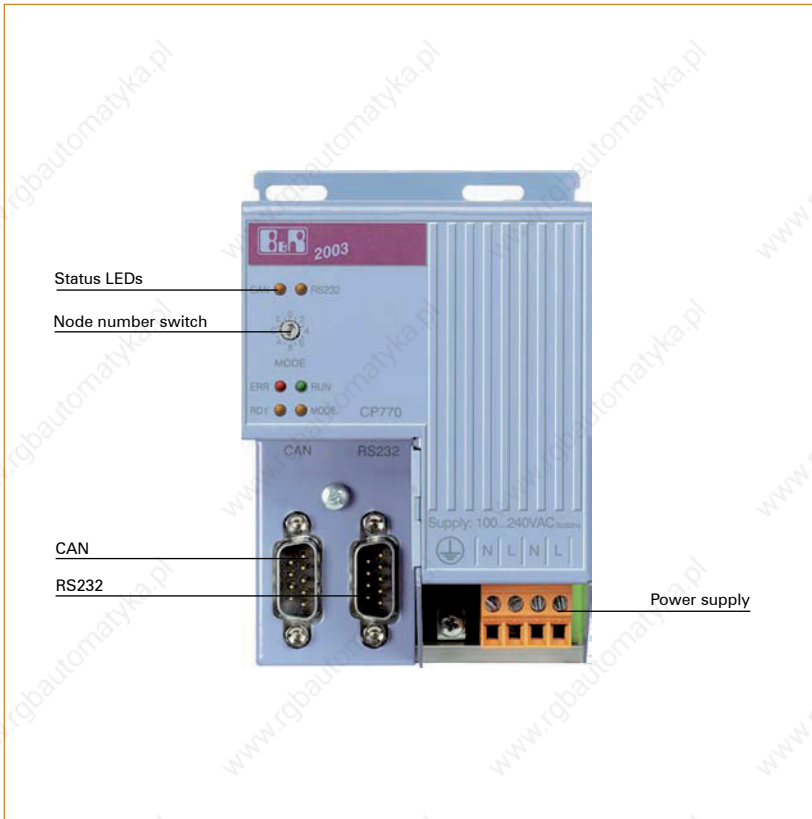

The CPU CP770 is positioned in the middle performance class for the System 2003. It is equipped with an RS232 and a CAN interface.

The RS232 interface is primarily intended for programming the CPU. It can also be used as a general interface for connecting visualization units, printers, or barcode readers.

The CAN fieldbus interface is used for communicating with other control systems and for remote expansion of inputs and outputs with System 2003 components and a CAN bus controller, e.g. EX470.

The CP770 CPU corresponds to the CP470 with a power supply of 100 to 240 VAC.

- 100 KB User SRAM
- 256 KB User FlashPROM
- RS232 and CAN interface
- Operation of 8 I/O modules
- 100 - 240 VAC supply



Short description	7CP770.60-1
System module	CPU
Interfaces	1 x RS232, 1 x CAN
Controller	7CP770.60-1
Fastest task class cycle time	1 ms
Typical instruction cycle time	1.6 μ s
Standard memory	
User RAM	100 KB SRAM
System PROM	256 KB FlashPROM
User PROM	256 KB FlashPROM
Data buffering	
Lithium battery	Typ. 3 years
Battery monitoring	Yes
Hardware watchdog	Yes
Voltage monitoring	Internal supply monitored for overvoltage and undervoltage
Real-time clock	Nonvolatile memory, resolution 1 second
I/O bus interface	9-pin DSUB socket

Interfaces		7CP770.60-1
Interface IF1		
Type		RS232
Design		9-pin DSUB plug
Maximum transfer rate		57.6 kBit/s
Interface IF2		
Type		CAN bus
Design		9-pin DSUB plug
Maximum transfer rate		500 kBit/s
Power supply		7CP770.60-1
Input voltage		100 - 240 VAC
Voltage range		85 VAC to 264 VAC
Input voltage frequency		47 to 63 Hz
Power consumption		20.0 W
Output power for I/O ports		14.0 W ¹⁾
1) Integrated power supply on pin 4 of the RS232 interface for simple Panelware controllers, e.g. P126		
General information		7CP770.60-1
Status indicators		CPU function, RS232, CAN bus
Diagnostics		
CPU function		Yes, with status LED
RS232		Yes, with status LED
CAN		Yes, with status LED
Operation on module slot		1
Logical module slots		Max. 8
Analog module slots		Max. 4
Possible module addresses for analog modules		1 - 8, for description see section "Module slot rules" 123
Visual Components-capable		No
ACOPOS-capable		No
Electrical isolation		
PLC - IF1		No
PLC - IF2		Yes
IF1 - IF2		Yes
Certification		CE, C-UL-US, GOST-R
Mechanical characteristics		7CP770.60-1
Dimensions		System 2003 single-width
Protection type		IP20
Operating temperature		
Horizontal installation		0°C to +60°C
Vertical installation		0°C to +50°C
Storage temperature		-25°C to +60°C
Relative humidity		5 to 95%, non-condensing
Comment		Backup battery included in delivery

Optional accessories	
4A0006.00-000	Lithium battery, 3 V / 950 mAh, button cell
0AC201.9	Lithium batteries, 5 pcs., 3 V / 950 mAh, button cell
0G0001.00-090	Cable PC <-> PLC/PW, RS232, online cable
7AC911.9	Bus connector, CAN
0AC912.9	Bus adapter, CAN, 1 CAN interface
0AC913.92	Bus adapter, CAN, 2 CAN interfaces, including 30 cm connection cable (DSUB connector)

CPU CP470



The CPU CP470 is positioned in the middle performance class for the System 2003. It is equipped with an RS232 and a CAN interface.

The RS232 interface is primarily intended for programming the CPU. It can also be used as a general interface for connecting visualization units, printers, or barcode readers.

The CAN fieldbus interface is used for communicating with other control systems and for remote expansion of inputs and outputs with System 2003 components and a CAN bus controller, e.g. EX470.

Data buffering and nonvolatile operation of the real-time clock are guaranteed by the lithium battery provided.

- 350 KB User SRAM
- 512 KB User FlashPROM
- RS232 and CAN interface
- Operation of 8 I/O modules



Short description	7CP470.60-2
System module	CPU
Interfaces	1 x RS232, 1 x CAN
Controller	7CP470.60-2
Fastest task class cycle time	1 ms
Typical instruction cycle time	1.6 μ s
Standard memory	
User RAM	350 KB SRAM
System PROM	512 KB FlashPROM
User PROM	512 KB FlashPROM
Data buffering	
Lithium battery	Typ. 3 years
Battery monitoring	Yes
Hardware watchdog	Yes
Voltage monitoring	Internal supply monitored for overvoltage and undervoltage
Real-time clock	Nonvolatile memory, resolution 1 second
I/O bus interface	9-pin DSUB socket

Interfaces 7CP470.60-2

Interface IF1	
Type	RS232
Design	9-pin DSUB plug
Maximum transfer rate	57.6 kBit/s

Interface IF2	
Type	CAN bus
Design	9-pin DSUB plug
Maximum transfer rate	500 kBit/s

Power supply 7CP470.60-2

Input voltage	24 VDC
Voltage range	18 VDC to 30 VDC
Power consumption	20.0 W
Output power for I/O ports	14.0 W ¹⁾

1) Integrated power supply on pin 4 of the RS232 interface for simple Panelware controllers, e.g. P126

General information 7CP470.60-2

Status indicators	CPU function, RS232, CAN
-------------------	--------------------------

Diagnostics	
CPU function	Yes, with status LED
RS232	Yes, with status LED
CAN	Yes, with status LED

Operation on module slot	1
--------------------------	---

Logical module slots	Max. 8
----------------------	--------

Analog module slots	Max. 4
---------------------	--------

Possible module addresses for analog modules	1 - 8, for description see section "Module slot rules" 	123
--	--	-----

Visual Components-capable	No
---------------------------	----

ACOPOS-capable	No
----------------	----

Electrical isolation	
PLC - IF1	No
PLC - IF2	Yes
IF1 - IF2	Yes

Certification	CE, C-UL-US, GOST-R
---------------	---------------------

Mechanical characteristics 7CP470.60-2

Dimensions	System 2003 single-width
------------	--------------------------

Protection type	IP20
-----------------	------

Operating temperature	
Horizontal installation	0°C to +60°C
Vertical installation	0°C to +50°C

Storage temperature	-25°C to +60°C
---------------------	----------------

Relative humidity	5 to 95%, non-condensing
-------------------	--------------------------

Comment	Backup battery included in delivery
---------	-------------------------------------

Optional accessories

4A0006.00-000	Lithium battery, 3 V / 950 mAh, button cell
0AC201.9	Lithium batteries, 5 pcs., 3 V / 950 mAh, button cell
0G0001.00-090	Cable PC <-> PLC/PW, RS232, online cable
7AC911.9	Bus connector, CAN
0AC912.9	Bus adapter, CAN, 1 CAN interface
0AC913.92	Bus adapter, CAN, 2 CAN interfaces, including 30 cm connection cable (DSUB connector)

CPU CP430



The CPU CP430 is positioned in the lowest performance class for the System 2003. It is equipped with an RS232 and a CAN interface.

The RS232 interface is primarily intended for programming the CPU. It can also be used as a general interface for connecting visualization units, printers, or barcode readers.

The CAN fieldbus interface is used for communicating with other control systems and for remote expansion of inputs and outputs with System 2003 components and a CAN bus controller, e.g. EX470.

Data buffering and nonvolatile operation of the real-time clock are guaranteed by the lithium battery provided.

- 100 KB User SRAM
- 256 KB User FlashPROM
- RS232 and CAN interface
- Operation of 4 I/O modules



Short description	7CP430.60-1
System module	CPU
Interfaces	1 x RS232, 1 x CAN
Controller	7CP430.60-1
Fastest task class cycle time	1 ms
Typical instruction cycle time	1.6 μ s
Standard memory	
User RAM	100 KB SRAM
System PROM	256 KB FlashPROM
User PROM	256 KB FlashPROM
Data buffering	
Lithium battery	Typ. 3 years
Battery monitoring	Yes
Hardware watchdog	Yes
Voltage monitoring	Internal supply monitored for overvoltage and undervoltage
Real-time clock	Nonvolatile memory, resolution 1 second
I/O bus interface	9-pin DSUB socket

Interfaces		7CP430.60-1
Interface IF1		
Type		RS232
Design		9-pin DSUB plug
Maximum transfer rate		57.6 kBit/s
Interface IF2		
Type		CAN bus
Design		9-pin DSUB plug
Maximum transfer rate		500 kBit/s
Power supply		7CP430.60-1
Input voltage		24 VDC
Voltage range		18 VDC to 30 VDC
Power consumption		9.5 W
Output power for I/O ports		7.0 W ¹⁾
1) Integrated power supply on pin 4 of the RS232 interface for simple Panelware controllers, e.g. P126		
General information		7CP430.60-1
Status indicators		CPU function, RS232, CAN
Diagnostics		
CPU function		Yes, with status LED
RS232		Yes, with status LED
CAN		Yes, with status LED
Operation on module slot		1
Logical module slots		Max. 4
Analog module slots		Max. 2
Possible module addresses for analog modules		1 - 4, for description see section "Module slot rules" 123
Visual Components-capable		No
ACOPOS-capable		No
Electrical isolation		
PLC - IF1		No
PLC - IF2		Yes
IF1 - IF2		Yes
Certification		CE, C-UL-US, GOST-R
Mechanical characteristics		7CP430.60-1
Dimensions		System 2003 single-width
Protection type		IP20
Operating temperature		
Horizontal installation		0°C to +60°C
Vertical installation		0°C to +50°C
Storage temperature		-25°C to +60°C
Relative humidity		5 to 95%, non-condensing
Comment		Backup battery included in delivery

Optional accessories	
4A0006.00-000	Lithium battery, 3 V / 950 mAh, button cell
0AC201.9	Lithium batteries, 5 pcs., 3 V / 950 mAh, button cell
0G0001.00-090	Cable PC <-> PLC/PW, RS232, online cable
7AC911.9	Bus connector, CAN
0AC912.9	Bus adapter, CAN, 1 CAN interface
0AC913.92	Bus adapter, CAN, 2 CAN interfaces, including 30 cm connection cable (DSUB connector)

Bus controller EX270



The EX270 bus controller is the communication interface to the CAN bus for a remote I/O system.

- Initialization - from power-on to active operation on the network
- Evaluating and sending input states
- Cyclic or event-driven sending of the input status
- Receiving and switching the outputs
- Defined error behavior for network crashes and local disturbances

Setting and changing the operating parameters can be done either with a special instruction that is sent from a CAN client (master) or using configuration memory.

CAN

Short description	7EX270.50-1
Bus controller	CAN I/O slave
Peripherals	7EX270.50-1
I/O bus interface	9-pin DSUB socket
Number switch	For setting the node number and transfer rate
Interfaces	7EX270.50-1
Interface IF1	
Fieldbus	CAN I/O slave
Design	12-pin multipoint connector
Maximum transfer rate	500 kBit/s
Power supply	7EX270.50-1
Input voltage	24 VDC
Voltage range	18 VDC to 30 VDC
Power consumption	5.0 W
Output power for I/O modules and screw-in modules	4.0 W
Voltage monitoring	The power supply is only enabled starting with an input voltage of approx. +15 V. Therefore, the DC OK status LED is not necessary.
General information	7EX270.50-1
Status indicators	Module status
Diagnostics	
Module status	Yes, with status LED
Logical module slots	Max. 4
Analog module slots	Max. 2
Possible module addresses for analog modules	1 - 2, for description see section "Module slot rules" 123
Electrical isolation	
PLC - IF1	Yes
Certification	CE, C-UL-US, GOST-R
Mechanical characteristics	7EX270.50-1
Module width	20 mm
Installation	Bus controller screwed onto the module rack instead of the left side plate
Protection type	IP20
Operating temperature	
Horizontal installation	0°C to +60°C
Vertical installation	0°C to +50°C
Storage temperature	-25°C to +70°C
Relative humidity	5 to 95%, non-condensing
Comment	1 x TB712 terminal block separately

Required accessories	
7TB712.9	Accessory terminal block, 12-pin, screw clamp, 1.5 mm ²
7TB712.91	Accessory terminal block, 12-pin, cage clamp, 1.5 mm ²

Bus controller EX290



The EX290 bus controller is the communication interface between X2X Link and the I/O system.

- Initialization - from power-on to active operation on the X2X Link
- Evaluating and sending input states
- Receiving and switching the outputs
- Defined error behavior for X2X Link crashes and local disturbances

Short description	7EX290.50-1
Bus controller	X2X Link slave
Peripherals	7EX290.50-1
I/O bus interface	9-pin DSUB socket
Interfaces	7EX290.50-1
Interface IF1	
Type	X2X Link slave
Design	12-pin multipoint connector
Power supply	7EX290.50-1
Input voltage	24 VDC
Voltage range	18 VDC to 30 VDC
Power consumption	5.0 W
Output power for I/O modules and screw-in modules	3.2 W
Voltage monitoring	The power supply is only enabled starting with an input voltage of approx. +15 V. Therefore, the DC OK status LED is not necessary.
General information	7EX290.50-1
Status indicators	Module status
Diagnostics	
Module status	Yes, with status LED
Logical module slots	Max. 4
Analog module slots	Max. 2
Possible module addresses for analog modules	1 - 4, for description see section "Module slot rules" 123
Electrical isolation	
PLC - IF1	Yes
Certification	CE, C-UL-US, GOST-R
Mechanical characteristics	7EX290.50-1
Module width	20 mm
Installation	Controller screwed onto the module rack instead of the left side plate
Protection type	IP20
Operating temperature	
Horizontal installation	0°C to +60°C
Vertical installation	0°C to +50°C
Storage temperature	-25°C to +70°C
Relative humidity	5 to 95%, non-condensing
Comment	1 x TB712 terminal block separately

Required accessories	
7TB712.9	Accessory terminal block, 12-pin, screw clamp, 1.5 mm ²
7TB712.91	Accessory terminal block, 12-pin, cage clamp, 1.5 mm ²

Bus controller EX470



The EX470 bus controller is the communication interface to the CAN bus for a remote I/O system.

- Initialization - from power-on to active operation on the network
- Evaluating and sending input states
- Cyclic or event-driven sending of the input status
- Receiving and switching the outputs
- Defined error behavior for network crashes and local disturbances

Setting and changing the operating parameters can be done either with a special instruction that is sent from a CAN client (master) or using configuration memory.

CAN

Short description	7EX470.50-1
Bus controller	CAN I/O slave
Peripherals	7EX470.50-1
I/O bus interface	9-pin DSUB socket
Number switch	For setting the node number and transfer rate
Interfaces	7EX470.50-1
Interface IF1	
Fieldbus	CAN I/O slave
Design	9-pin DSUB plug
Maximum transfer rate	500 kBit/s
Interface IF2	
Fieldbus	CAN I/O slave
Design	9-pin DSUB socket
Maximum transfer rate	500 kBit/s
Power supply	7EX470.50-1
Input voltage	24 VDC
Voltage range	18 VDC to 30 VDC
Power consumption	20.0 W
Output power for I/O modules and screw-in modules	14.5 W, starts with revision 30.xx
General information	7EX470.50-1
Status indicators	Module status
Diagnostics	
Module status	Yes, with status LED
Operation on module slot	1
Logical module slots	Max. 8
Analog module slots	Max. 4
Possible module addresses for analog modules	1 - 4, for description see section "Module slot rules" 123
Electrical isolation	
PLC - IF1	Yes
PLC - IF2	Yes
Certification	CE, C-UL-US, GOST-R
Mechanical characteristics	7EX470.50-1
Dimensions	System 2003 single-width
Protection type	IP20
Operating temperature	
Horizontal installation	0°C to +60°C, starting from revision 30.xx
Vertical installation	0°C to +50°C
Storage temperature	-25°C to +70°C
Relative humidity	5 to 95%, non-condensing

Optional accessories	
7AC911.9	Bus connector, CAN
0AC912.9	Bus adapter, CAN, 1 CAN interface
0AC913.92	Bus Adapter, CAN, 2 CAN interfaces, including 30 cm connection cable
7ME770.5	System 2003 configuration memory for CAN bus controller 108

Bus controller EX770



The EX770 bus controller is the communication interface to the CAN bus for a remote I/O system.

- Initialization - from power-on to active operation on the network
- Evaluating and sending input states
- Cyclic or event-driven sending of the input status
- Receiving and switching the outputs
- Defined error behavior for network crashes and local disturbances
- 100 - 240 VAC supply

Setting and changing the operating parameters can be done either with a special instruction that is sent from a CAN client (master) or using configuration memory.

CAN

Short description	7EX770.50-1
Bus controller	CAN I/O slave
Peripherals	7EX770.50-1
I/O bus interface	9-pin DSUB socket
Number switch	For setting the node number and transfer rate
Interfaces	7EX770.50-1
Interface IF1	
Fieldbus	CAN I/O slave
Design	9-pin DSUB plug
Maximum transfer rate	500 kBit/s
Interface IF2	
Fieldbus	CAN I/O slave
Design	9-pin socket
Maximum transfer rate	500 kBit/s
Power supply	7EX770.50-1
Input voltage	100 - 240 VAC
Voltage range	85 VAC to 264 VAC
Input voltage frequency	47 to 63 Hz
Power consumption	20.0 W
Output power for I/O modules and screw-in modules	14.5 W, starts with revision 10.xx
General information	7EX770.50-1
Status indicators	Module status
Diagnostics	
Module status	Yes, with status LED
Operation on module slot	1
Logical module slots	Max. 8
Analog module slots	Max. 4
Possible module addresses for analog modules	1 - 4, for description see section "Module slot rules" 123
Electrical isolation	
PLC - IF1	Yes
PLC - IF2	Yes
Certification	CE, C-UL-US, GOST-R
Mechanical characteristics	7EX770.50-1
Dimensions	System 2003 single-width
Protection type	IP20
Operating temperature	
Horizontal installation	0°C to +60°C, starting from revision 10.xx
Vertical installation	0°C to +50°C
Storage temperature	-25°C to +70°C
Relative humidity	5 to 95%, non-condensing

Optional accessories	
7AC911.9	Bus connector, CAN
0AC912.9	Bus adapter, CAN, 1 CAN interface
0AC913.92	Bus adapter, CAN, 2 CAN interfaces, including 30 cm connection cable
7ME770.5	System 2003 configuration memory for CAN bus controller 108

Bus controller EX481



Remote I/O can be connected to an ETHERNET Powerlink network using the ETHERNET Powerlink EX481 bus controller.

- Initialization - from power-on to active operation on the network
- Evaluating and sending input states
- Receiving and switching the outputs
- Defined error behavior for network crashes and local disturbances



Short description	7EX481.50-1
Bus controller	ETHERNET Powerlink controlled node
Peripherals	7EX481.50-1
I/O bus interface	9-pin DSUB socket
Station number switches	For setting the Powerlink station number
Interfaces	7EX481.50-1
Interface IF1	
Fieldbus	ETHERNET Powerlink
Type	100 Base-T (ANSI/IEEE 802.3)
Design	Shielded RJ45 port
Transfer rate	100 MBit/s
Cable length	Max. 100 m between two stations (segment length)
Power supply	7EX481.50-1
Design	Switching power supply with reverse polarity diode
Input voltage	24 VDC
Voltage range	18 VDC to 30 VDC
Power consumption	20.0 W
Output power for I/O modules and screw-in modules	13.4 W
General information	7EX481.50-1
Status indicators	Module status
Diagnostics	
Module status	Yes, with status LED
Operation on module slot	1
Logical module slots	Max. 16
Analog module slots	Max. 8
Possible module addresses for analog modules	1 - 8, for description see section "Module slot rules"  123
Electrical isolation	
PLC - IF1	Yes
Certification	CE, C-UL-US, GOST-R
Mechanical characteristics	7EX481.50-1
Dimensions	System 2003 single-width
Protection type	IP20
Operating temperature	
Horizontal installation	0°C to +60°C
Vertical installation	0°C to +50°C
Storage temperature	-25°C to +70°C
Relative humidity	5 to 95%, non-condensing

Bus controller EX484



Remote I/Os can be connected to an ETHERNET Powerlink network using the ETHERNET Powerlink EX484 bus controller.

- Initialization - from power-on to active operation on the network
- Evaluating and sending input states
- Receiving and switching the outputs
- Defined error behavior for network crashes and local disturbances
- Integrated 4x hub



Short description	7EX484.50-1
Bus controller	ETHERNET Powerlink controlled node
Peripherals	7EX484.50-1
I/O bus interface	9-pin DSUB socket
Station number switches	For setting the Powerlink station number
Interfaces	7EX484.50-1
Interface IF1	
Fieldbus	ETHERNET Powerlink
Type	100 Base-T (ANSI/IEEE 802.3)
Design	Internal 4x hub, 4 x shielded RJ45 port
Transfer rate	100 MBit/s
Cable length	Max. 100 m between two stations (segment length)
Power supply	7EX484.50-1
Design	Switching power supply with reverse polarity diode
Input voltage	24 VDC
Voltage range	18 VDC to 30 VDC
Power consumption	20.0 W
Output power for I/O modules and screw-in modules	10.4 W
General information	7EX484.50-1
Status indicators	Module status
Diagnostics	
Module status	Yes, with status LED
Operation on module slot	1
Logical module slots	Max. 16
Analog module slots	Max. 8
Possible module addresses for analog modules	1 - 8, for description see section "Module slot rules"  123
Electrical isolation	
PLC - IF1	Yes
Certification	CE, C-UL-US, GOST-R
Mechanical characteristics	7EX484.50-1
Dimensions	System 2003 single-width
Protection type	IP20
Operating temperature	
Horizontal installation	0°C to +60°C
Vertical installation	0°C to +50°C
Storage temperature	-25°C to +70°C
Relative humidity	5 to 95%, non-condensing

Adapter module AF101

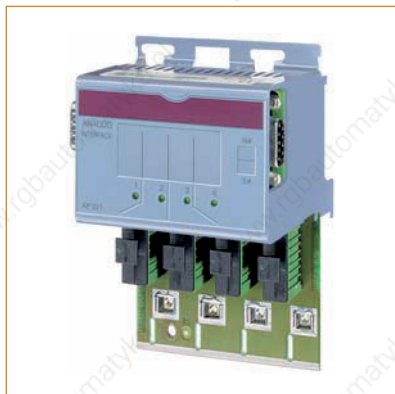

Screw-in modules are either inserted on local slots of the CPU or on the adapter module and then screwed firmly into place. Information about which screw-in modules can be operated with the adapter module can be found in the technical data for the screw-in module.

Short description	7AF101.7
I/O module	Adapter module for screw-in modules
Adapter module	7AF101.7
Slots for screw-in modules	4
Suitable for IF modules	-
General information	7AF101.7
Status indicators	Operating state per screw-in module
Diagnostics	
Operating state of screw-in modules	Yes, with status LED
Number of operable modules with	
CP430, EX270, EX290	2
CP470, CP770, CP474, CP476, CP774	4
EX470, EX770, EX481, EX484	
CP570	8
Electrical isolation	
PLC - Slots for screw-in modules	No
Power consumption	0.3 W
Certification	CE, C-UL-US, GOST-R
Mechanical characteristics	7AF101.7
Dimensions	System 2003 single-width
Protection type	IP20
Operating temperature	
Horizontal installation	0°C to +60°C
Vertical installation	0°C to +50°C
Storage temperature	-25°C to +70°C
Relative humidity	5 to 95%, non-condensing

Adapter module AF104

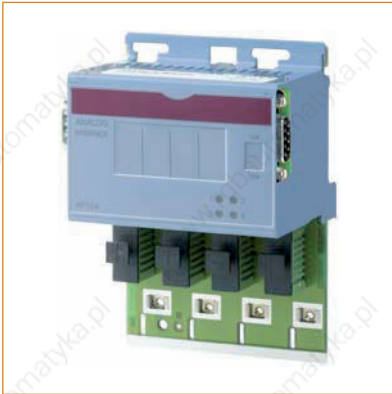

Screw-in modules are either inserted on local slots of the CPU or on the adapter module and then screwed firmly into place.

Information about which screw-in modules can be operated with the adapter module can be found in the technical data for the screw-in module.

The AF104 adapter module increases the analog performance of the System 2003, mainly through the parallel operation of several inserted screw-in modules.

Short description	7AF104.7
I/O module	Adapter module for screw-in modules
Adapter module	7AF104.7
Slots for screw-in modules	4
Suitable for IF modules	-
General information	7AF104.7
Status indicators	Operating state per screw-in module
Diagnostics	
Operating state of screw-in modules	Yes, with status LED
Number of operable modules with	
CP430, EX270, EX290	2
CP470, CP770, CP474, CP476, CP774	4
EX470, EX770, EX481, EX484	
CP570	8
Electrical isolation	
PLC - Slots for screw-in modules	No
Power consumption	0.9 W
Certification	CE, C-UL-US, GOST-R
Mechanical characteristics	7AF104.7
Dimensions	System 2003 single-width
Protection type	IP20
Operating temperature	
Horizontal installation	0°C to +60°C
Vertical installation	0°C to +50°C
Storage temperature	-25°C to +70°C
Relative humidity	5 to 95%, non-condensing

Digital input module DI135



The DI135 digital input module is a screw-in module for the System 2003 and Power Panel.

They can be used for the following tasks:

- TPU functions
- Counting and measuring digital signals (internal measurement frequency 4 MHz)
- Gate measurement
- Frequency measurement
- Event counting
- Incremental encoder operation
- Reaction to input events in the μs range
- Local counter status monitoring with direct output control

Short description	7DI135.70
I/O module	4 digital inputs, 1 digital output, special functions
Digital inputs	7DI135.70
Number of channels	4
Rated voltage	24 VDC
Input filter	
Hardware	$\leq 3 \mu\text{s}$
Software	-
Input circuit	Sink
Additional functions for inputs	2 x event counters, 1 x incremental encoder ABR (+24 V)
Incremental encoder operation	7DI135.70
Number	1
Counter size	32-bit
Input frequency	50 kHz
Evaluation	4-fold
Signal form	Square wave pulse
Event counter operation	7DI135.70
Number	2
Counter size	16-bit
Input frequency	100 kHz
Evaluation	Every rising edge or both edges, cyclical counters
Signal form	Square wave pulse
Digital outputs	7DI135.70
Number of channels	1
Rated voltage	24 VDC
Rated output current	0.5 A
Output circuit	Source
Output protection	Reverse polarity protection, short circuit protection
Additional functions for outputs	Fast comparator output, reaction time $< 50 \mu\text{s}$
Sensor supply	External
General information	7DI135.70
Electrical isolation	
Channel - PLC	Yes
Channel - Channel	No
Group isolation	Input group - Output group
Power consumption	0.4 W
Certification	CE, C-UL-US, GOST-R
Mechanical characteristics	7DI135.70
Slot	Adapter module, CPU with local slots for System 2003 screw-in modules
Protection type	IP20
Operating temperature	
Horizontal installation	0°C to +60°C
Vertical installation	0°C to +50°C
Storage temperature	-25°C to +70°C
Relative humidity	5 to 95%, non-condensing
Comment	1 x TB712 terminal block separately

Required accessories	
7TB712.9	Accessory terminal block, 12-pin, screw clamp, 1.5 mm ²
7TB712.91	Accessory terminal block, 12-pin, cage clamp, 1.5 mm ²

Digital input module DI138



The DI138 digital input module is a screw-in module for the System 2003 and Power Panel. It has 10 inputs for VDC, two of which are equipped with counter functions. Additionally, the module is equipped with supply voltage monitoring.

Short description	7DI138.70
I/O module	10 digital inputs 24 VDC, special functions
Digital inputs	7DI138.70
Rated voltage	24 VDC
Input filter	
Hardware	
Inputs 5 and 6	≤3 μs
Other inputs	≤1.3 ms
Software	-
Input circuit	Sink
Additional functions for inputs	2 x event counter
Event counter operation	7DI138.70
Number	2
Counter size	16-bit
Input frequency	20 kHz
Evaluation	Every rising edge or both edges, cyclical counters
Signal form	Square wave pulse
General information	7DI138.70
Electrical isolation	
Channel - PLC	Yes
Channel - Channel	No
Power consumption	0.4 W
Certification	CE, C-UL-US, GOST-R
Mechanical characteristics	7DI138.70
Slot	Adapter module, CPU with local slots for System 2003 screw-in modules
Protection type	IP20
Operating temperature	
Horizontal installation	0°C to +60°C
Vertical installation	0°C to +50°C
Storage temperature	-25°C to +70°C
Relative humidity	5 to 95%, non-condensing
Comment	1 x TB712 terminal block separately

Required accessories	
7TB712.9	Accessory terminal block, 12-pin, screw clamp, 1.5 mm ²
7TB712.91	Accessory terminal block, 12-pin, cage clamp, 1.5 mm ²

Digital input module DI140



The DI140 digital input module is a screw-in module for the System 2003 and Power Panel. It has 10 inputs for 24 VDC, four of which are equipped with counter functions.

For this, there is a difference between the operating modes event counter and encoder. The DI140 also offers TPU functions and supply voltage monitoring.

- Can be used with TPU functions

Short description	7DI140.70
I/O module	10 digital inputs 24 VDC, special functions
Digital inputs	7DI140.70
Rated voltage	24 VDC
Input filter	
Hardware	
Inputs 1 - 7	≤3 μs
Inputs 8 - 10	≤1.3 ms
Software	-
Input circuit	Sink
Additional functions for inputs	2 x event counters, 1 x incremental encoder ABR (+24 V)
Incremental encoder operation	7DI140.70
Number	1
Counter size	32-bit
Input frequency	50 kHz
Evaluation	4-fold
Signal form	Square wave pulse
Event counter operation	7DI140.70
Number	2
Counter size	16-bit
Input frequency	50 kHz
Evaluation	Every rising edge or both edges, cyclical counters
Signal form	Square wave pulse
General information	7DI140.70
Electrical isolation	
Channel - PLC	Yes
Channel - Channel	No
Power consumption	0.4 W
Certification	CE, C-UL-US, GOST-R
Mechanical characteristics	7DI140.70
Slot	Adapter module, CPU with local slots for System 2003 screw-in modules
Protection type	IP20
Operating temperature	
Horizontal installation	0°C to +60°C
Vertical installation	0°C to +50°C
Storage temperature	-25°C to +70°C
Relative humidity	5 to 95%, non-condensing
Comment	1 x TB712 terminal block separately

Required accessories	
7TB712.9	Accessory terminal block, 12-pin, screw clamp, 1.5 mm ²
7TB712.91	Accessory terminal block, 12-pin, cage clamp, 1.5 mm ²

Digital input module DI435



Digital input module with 8 channels, 24 VDC.

Short description	7DI435.7
I/O module	8 digital inputs - 24 VDC
Digital inputs	7DI435.7
Rated voltage	24 VDC
Input filter	
Hardware	≤1 ms
Software	-
Input circuit	Sink or source
General information	7DI435.7
Status indicators	I/O function per channel, I/O supply
Diagnostics	
I/O supply	Yes, with status LED and software status
Number of operable modules with	
CP430, EX270, EX290	4
CP470, CP770, CP474, CP476, CP774	8
EX470, EX770, EX481, EX484	
CP570	9
Electrical isolation	
Channel - PLC	Yes
Channel - Channel	No
Power consumption	0.2 W
Certification	CE, C-UL-US, GOST-R
Mechanical characteristics	7DI435.7
Dimensions	System 2003 single-width
Protection type	IP20
Operating temperature	
Horizontal installation	0°C to +60°C
Vertical installation	0°C to +50°C
Storage temperature	-25°C to +70°C
Relative humidity	5 to 95%, non-condensing
Comment	3 x TB710 terminal block separately

Required accessories	
7TB710.9	Accessory terminal block, 10-pin, screw clamp, 1.5 mm ²
7TB710.91	Accessory terminal block, 10 pin, cage clamp, 2.5 mm ²

Digital input module DI439.7



Digital input module with 16 channels, 24 VDC.

Short description	7DI439.7
I/O module	16 digital inputs - 24 VDC
Digital inputs	7DI439.7
Rated voltage	24 VDC
Input filter	
Hardware	≤ 1 ms
Software	-
Input circuit	Sink or source
General information	7DI439.7
Status indicators	I/O function per channel, I/O supply
Diagnostics	
I/O supply	Yes, with status LED and software status
Number of operable modules with ¹⁾	
CP430, EX270, EX290	2
CP470, CP770, EX470, EX770	4
CP474, CP774	6
CP476, EX481, EX484	8
CP570	8
Electrical isolation	
Channel - PLC	Yes
Channel - Channel	No
Power consumption	0.4 W
Certification	CE, C-UL-US, GOST-R
1) Two logical module slots are required by the module.	
Mechanical characteristics	7DI439.7
Dimensions	System 2003 single-width
Protection type	IP20
Operating temperature	
Horizontal installation	0°C to +60°C
Vertical installation	0°C to +50°C
Storage temperature	-25°C to +70°C
Relative humidity	5 to 95%, non-condensing
Comment	3 x TB718 terminal block separately

Required accessories	
7TB718.9	Accessory terminal block, 18-pin, screw clamp, 1.5 mm ²
7TB718.91	Accessory terminal block, 18-pin, cage clamp, 1.5 mm ²

Digital input module DI439.72



Digital input module with 16 channels, 24 VDC.

- DSUB connectors for connecting I/O

Short description	7DI439.72
I/O module	16 digital inputs 24 VDC in 2 groups
Digital inputs	7DI439.72
Rated voltage	24 VDC
Input filter	
Hardware	≤1 ms
Software	-
Input circuit	Sink or source
General information	7DI439.72
Status indicators	I/O function per channel, I/O supply
Diagnostics	
I/O supply	Yes, with status LED and software status
Number of operable modules with ¹⁾	
CP430, EX270, EX290	2
CP470, CP770, EX470, EX770	4
CP474, CP774	6
CP476, EX481, EX484	8
CP570	8
Electrical isolation	
Channel - PLC	Yes
Group - Group	Yes
Channel - Channel	No (same group)
Power consumption	0.4 W
Certification	CE, C-UL-US, GOST-R
1) Two logical module slots are required by the module.	
Mechanical characteristics	7DI439.72
Dimensions	System 2003 single-width
Protection type	IP20
Operating temperature	
Horizontal installation	0°C to +60°C
Vertical installation	0°C to +50°C
Storage temperature	-25°C to +70°C
Relative humidity	5 to 95%, non-condensing
Comment	Connection made using DSUB connectors

Digital input module DI645

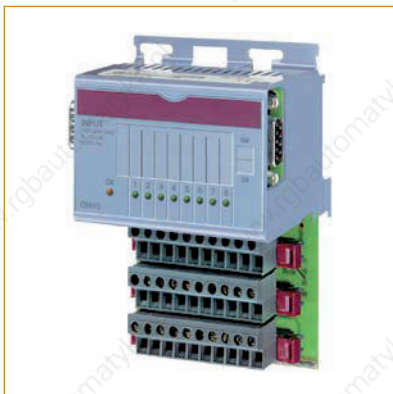

Digital input module with 8 channels,
100 - 240 VAC.

Short description	7DI645.7
I/O module	8 digital inputs 100 - 240 VAC
Digital inputs	7DI645.7
Rated voltage	100 - 240 VAC
Rated frequency	47 - 63 Hz
Input filter	
Hardware	≤50 ms
Software	-
General information	7DI645.7
Status indicators	I/O function per channel, I/O supply
Diagnostics	
I/O supply	Yes, with status LED and software status
Number of operable modules with	
CP430, EX270, EX290	4
CP470, CP770, CP474, CP476, CP774	8
EX470, EX770, EX481, EX484	
CP570	9
Electrical isolation	
Channel - PLC	Yes
Channel - Channel	No
Power consumption	0.2 W
Certification	CE, C-UL-US, GOST-R
Mechanical characteristics	7DI645.7
Dimensions	System 2003 single-width
Protection type	IP20
Operating temperature	
Horizontal installation	0°C to +60°C
Vertical installation	0°C to +50°C
Storage temperature	-25°C to +70°C
Relative humidity	5 to 95%, non-condensing
Comment	3 x TB710 terminal block separately

Required accessories	
7TB710.9	Accessory terminal block, 10-pin, screw clamp, 1.5 mm ²
7TB710.91	Accessory terminal block, 10 pin, cage clamp, 2.5 mm ²

Digital output module DO135



The DO135 is a 4-channel output module. The operating mode can be set separately for each output. The following operating modes are available:

- Normal operation - switching on/off the outputs
- Pulse width modulation (PWM) - periodic switching on/off the outputs; pulse width ratio, period length and resolution configurable
- TPU operation; for high-speed signal processing; outputs controlled with TPU

Special functions

- The supply voltage is tested to ensure a valid range (10.5 VDC < U_s < 30 VDC)
- The channels are equipped with a readable power cut-off

Short description	7DO135.70
I/O module	4 digital outputs 12 - 24 VDC, special functions
Digital outputs	7DO135.70
Rated voltage	12 - 24 VDC
Rated output current	0.1 A
Total current	0.4 A
Output circuit	Push/Pull
Output protection	Thermal cutoff for overcurrent or short circuit, integrated protection for switching inductances, reverse polarity protection for output supply
Additional functions for outputs	Pulse width modulation, TPU operation
Sensor supply	External
General information	7DO135.70
Electrical isolation	
Channel - PLC	No
Channel - Channel	No
Power consumption	0.2 W
Certification	CE, C-UL-US, GOST-R
Mechanical characteristics	7DO135.70
Slot	Adapter module, CPU with local slots for System 2003 screw-in modules
Protection type	IP20
Operating temperature	
Horizontal installation	0°C to +60°C
Vertical installation	0°C to +50°C
Storage temperature	-25°C to +70°C
Relative humidity	5 to 95%, non-condensing
Comment	1 x TB712 terminal block separately

Required accessories

7TB712.9	Accessory terminal block, 12-pin, screw clamp, 1.5 mm ²
7TB712.91	Accessory terminal block, 12-pin, cage clamp, 1.5 mm ²

Digital output module DO138



The DO138 digital output module is a screw-in module for the System 2003 and Power Panel with 8 outputs.

Short description	7DO138.70
I/O module	8 digital outputs 24 VDC
Digital outputs	7DO138.70
Rated voltage	24 VDC
Rated output current	0.5 A
Total current	4.0 A
Output circuit	Source
Output protection	Thermal cutoff for overcurrent or short circuit, integrated protection for switching inductances, reverse polarity protection for output supply
Additional functions for outputs	To increase the output current, outputs can be switched in parallel
Sensor supply	External
General information	7DO138.70
Electrical isolation	
Channel - PLC	No
Channel - Channel	No
Power consumption	
Internal	0.25 W
External 24 V	1.5 W
Certification	CE, C-UL-US, GOST-R
Mechanical characteristics	7DO138.70
Slot	Adapter module, CPU with local slots for System 2003 screw-in modules
Protection type	IP20
Operating temperature	
Horizontal installation	0°C to +60°C
Vertical installation	0°C to +50°C
Storage temperature	-25°C to +70°C
Relative humidity	5 to 95%, non-condensing
Comment	1 x TB712 terminal block separately

Required accessories	
7TB712.9	Accessory terminal block, 12-pin, screw clamp, 1.5 mm ²
7TB712.91	Accessory terminal block, 12-pin, cage clamp, 1.5 mm ²

Digital output module DO139



The electrically isolated 8-channel DO139 digital output module can be wired either as highside or lowside or as a push/pull output for controlling DC motors with a nominal voltage of 12 - 24 VDC at nominal currents up to 0.5 A.

Normal and TPU mode operation is possible.

- TPU functions

Short description	7DO139.70
I/O module	8 digital outputs 12 - 24 VDC
Digital outputs	7DO139.70
Rated voltage	12 - 24 VDC
Rated output current	0.5 A
Total current	4.0 A
Output circuit	Highside - Lowside - Push/Pull
Output protection	Thermal cutoff for overcurrent or short circuit, integrated protection for switching inductances, reverse polarity protection of the output supply, blow-out fuse in the module
Additional functions for outputs	Controlling DC motors, TPU operation
Sensor supply	External
General information	7DO139.70
Diagnostics	
I/O supply	Yes, with software status
Outputs	Yes, with software status
Electrical isolation	
Channel - PLC	Yes
Channel - Channel	No
Power consumption	
Internal	0.25 W
External 24 V	1.8 W
Certification	CE, C-UL-US, GOST-R
Mechanical characteristics	7DO139.70
Slot	Adapter module, CPU with local slots for System 2003 screw-in modules
Protection type	IP20
Operating temperature	
Horizontal installation	0°C to +60°C
Vertical installation	0°C to +50°C
Storage temperature	-25°C to +70°C
Relative humidity	5 to 95%, non-condensing
Comment	1 x TB712 terminal block separately

Required accessories

7TB712.9	Accessory terminal block, 12-pin, screw clamp, 1.5 mm ²
7TB712.91	Accessory terminal block, 12-pin, cage clamp, 1.5 mm ²

Digital output module DO164



The screw-in module DO164 is equipped with four output channels. It is used to send ignition pulses (triac coupler) for phase-angle control of power triacs.

Short description	7DO164.70
I/O module	4 triac outputs 48 to 125 VAC
Triac outputs	7DO164.70
Design ¹⁾	Triac coupler, only to control power triacs or non-parallel thyristors
Rated voltage	48 to 125 VAC
Rated frequency	48 to 63 Hz
Rated output current	50 mA
Total current	0.2 A
Ignition pulse current	0.5 A
Sensor supply	External
1) Because of the very low (dV/dt) _c value of the triac coupler ("Critical rate of rise of commutating voltage"), the triac output is not suitable for use as an SSR relay for direct switching of loads.	
Zero voltage input (terminals 11 and 12)	7DO164.70
Number of channels	1
Rated voltage	48 to 125 VAC
Rated frequency	48 to 63 Hz
Input impedance in signal range	1 MΩ
Tolerance of the zero cross signal at 48 to 125 VAC	0 to 100 μs
General information	7DO164.70
Electrical isolation	
Output - PLC	Yes
Zero voltage input - PLC	No
Zero voltage input - output	Yes
Output - Output	Yes
Power consumption	0.6 W
Certification	CE, C-UL-US (in development), GOST-R
Mechanical characteristics	7DO164.70
Slot	Adapter module, CPU with local slots for System 2003 screw-in modules
Protection type	IP20
Operating temperature	
Horizontal installation	0°C to +60°C
Vertical installation	0°C to +50°C
Storage temperature	-25°C to +70°C
Relative humidity	5 to 95%, non-condensing
Comment	1 x TB712 terminal block separately

Required accessories	
7TB712.9	Accessory terminal block, 12-pin, screw clamp, 1.5 mm ²
7TB712.91	Accessory terminal block, 12-pin, cage clamp, 1.5 mm ²

Digital output module DO435



With this module, each channel can be configured either as an input or output. Each time the module is turned on, all channels are configured as inputs.

Derating curve

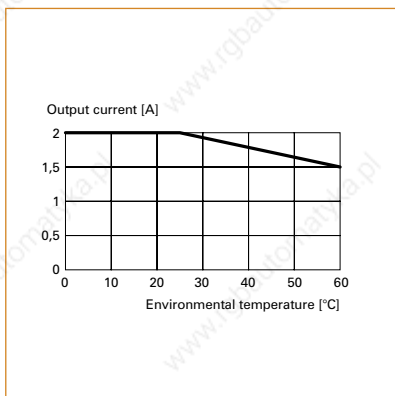

Short description	7DO435.7
I/O module	Up to 8 digital outputs, up to 8 digital inputs
Digital outputs	7DO435.7
Number of channels	Up to 8, configuration as input or output takes place using software
Rated voltage	24 VDC
Rated output current	2.0 A, see "Derating Curve"
Total current	8.0 A
Output circuit	Source
Output protection	Thermal cutoff for overcurrent or short circuit, integrated protection for switching inductances, reverse polarity protection for output supply
Sensor supply	External
Digital inputs	7DO435.7
Number of channels	Up to 8, configuration as input or output takes place using software
Rated voltage	24 VDC
Input filter	
Hardware	≤1 ms
Software	-
Input circuit	Sink
General information	7DO435.7
Status indicators	I/O function per channel, I/O supply
Diagnostics	
Outputs	Yes, with status LED
I/O supply	Yes, with status LED and software status
Number of operable modules with	
CP430, EX270, EX290	4
CP470, CP770, CP474, CP476, CP774	8
EX470, EX770, EX481, EX484	
CP570	9
Electrical isolation	
Channel - PLC	Yes
Channel - Channel	No
Power consumption	0.5 W
Certification	CE, C-UL-US, GOST-R
Mechanical characteristics	7DO435.7
Dimensions	System 2003 single-width
Protection type	IP20
Operating temperature	
Horizontal installation	0°C to +60°C
Vertical installation	0°C to +50°C
Storage temperature	-25°C to +70°C
Relative humidity	5 to 95%, non-condensing
Comment	3 x TB710 terminal block separately

Required accessories	
7TB710.9	Accessory terminal block, 10-pin, screw clamp, 1.5 mm ²
7TB710.91	Accessory terminal block, 10 pin, cage clamp, 2.5 mm ²

Digital output module DO720



Digital input module with 8 channels,
240 VAC / 30 VDC.

Short description	7DO720.7
I/O module	8 digital outputs 240 VAC / 30 VDC
Digital outputs	7DO720.7
Design	Relay / N.O.
Rated voltage	240 VAC / 30 VDC
Rated output current	2.0 A
Total current	12.0 A
Maximum switching power (AC)	480 VA
Maximum switching power (DC)	60 W
Sensor supply	External
General information	7DO720.7
Status indicators	I/O function per channel
Diagnostics	
Outputs	Yes, with status LED
Number of operable modules with	
EX270, EX290	2
CP430	4
CP470, CP770, CP474, CP476, CP774	8
EX470, EX770, EX481, EX484	
CP570	9, note derating
Electrical isolation	
Channel - PLC	Yes
Channel - Channel	No
Power consumption	1.4 W
Certification	CE, C-UL-US, GOST-R
Mechanical characteristics	7DO720.7
Dimensions	System 2003 single-width
Protection type	IP20
Operating temperature	
Horizontal installation	0°C to +60°C
Vertical installation	0°C to +50°C
Storage temperature	-25°C to +70°C
Relative humidity	5 to 95%, non-condensing
Comment	3 x TB710 terminal block separately

Required accessories	
7TB710.9	Accessory terminal block, 10-pin, screw clamp, 1.5 mm ²
7TB710.91	Accessory terminal block, 10 pin, cage clamp, 2.5 mm ²

Digital output module DO721



Digital input module with 4 channels,
240 VAC / 24 VDC.

Short description	7DO721.7
I/O module	4 digital outputs 24 VAC / 240 VDC, outputs are single-channel isolated
Digital outputs	7DO721.7
Design	Relay / changeover contact, channels are single-channel isolated
Rated voltage	240 VAC / 24 VDC
Rated output current	4.0 A
Total current	16.0 A
Maximum switching power (AC)	1000 VA
Maximum switching power (DC)	120 W at 30 VDC
Output protection	Blow-out fuse in the module
Sensor supply	External
General information	7DO721.7
Status indicators	I/O function per channel
Diagnostics	
Outputs	Yes, with status LED
Number of operable modules with	
EX270, EX290	2
CP430	4
CP470, CP770, CP474, CP476, CP774	8
EX470, EX770, EX481, EX484	
CP570	9, note derating
	21
Electrical isolation	
Channel - PLC	Yes
Channel - Channel	Yes
Power consumption	1.4 W
Certification	CE, C-UL-US, GOST-R
Mechanical characteristics	7DO721.7
Dimensions	System 2003 single-width
Protection type	IP20
Operating temperature	
Horizontal installation	0°C to +60°C
Vertical installation	0°C to +50°C
Storage temperature	-25°C to +70°C
Relative humidity	5 to 95%, non-condensing
Comment	Terminal blocks included in delivery

Required accessories	
7AC011.9	System 2003, stress relief attachment, 5 pcs., incl. mounting material
	108

Digital output module DO722

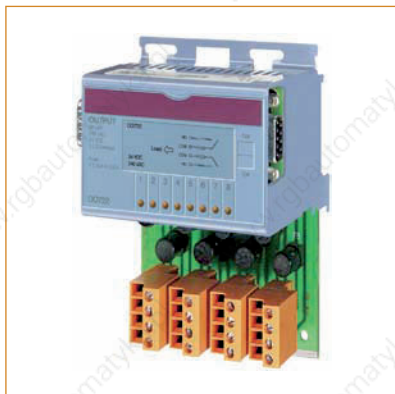

Digital input module with 8 channels,
240 VAC / 24 VDC.

Short description	7DO722.7
I/O module	8 digital outputs 24 VAC / 240 VDC, outputs are single-channel isolated
Digital outputs	7DO722.7
Design	Relay / normally open contacts, channels are single-channel isolated
Rated voltage	240 VAC / 24 VDC
Rated output current	2.5 A
Total current	20.0 A
Maximum switching power (AC)	625 VA
Maximum switching power (DC)	75 W at 30 VDC
Output protection	Blow-out fuse in the module
Sensor supply	External
General information	7DO722.7
Status indicators	I/O function per channel
Diagnostics	
Outputs	Yes, with status LED
Number of operable modules with	
EX270, EX290	2
CP430	4
CP470, CP770, CP474, CP476, CP774	8
EX470, EX770, EX481, EX484	
CP570	9, note derating
Electrical isolation	
Channel - PLC	Yes
Channel - Channel	Yes
Power consumption	1.4 W
Certification	CE, C-UL-US, GOST-R
Mechanical characteristics	7DO722.7
Dimensions	System 2003 single-width
Protection type	IP20
Operating temperature	
Horizontal installation	0°C to +60°C
Vertical installation	0°C to +50°C
Storage temperature	-25°C to +70°C
Relative humidity	5 to 95%, non-condensing
Comment	Terminal blocks included in delivery

Required accessories	
7AC011.9	System 2003, stress relief attachment, 5 pcs., incl. mounting material

Digital mixed module DM435



Digital input/output module with 8 channels, 24 VDC.

Short description	7DM435.7
I/O module	8 digital inputs, 8 digital outputs
Digital inputs	7DM435.7
Rated voltage	24 VDC
Input filter	
Hardware	≤1 ms
Software	-
Input circuit	Sink or source
Digital outputs	7DM435.7
Rated voltage	24 VDC
Rated output current	0.5 A
Total current	4.0 A
Output circuit	Source
Output protection	Thermal cutoff for overcurrent or short circuit, integrated protection for switching inductances, reverse polarity protection for output supply
Sensor supply	External
General information	7DM435.7
Status indicators	I/O function per channel, I/O supply
Diagnostics	
Outputs	Yes, with status LED
I/O supply	Yes, with status LED and software status
Number of operable modules with	
CP430, EX270, EX290	4
CP470, CP770, CP474, CP476, CP774	8
EX470, EX770, EX481, EX484	
CP570	9
Electrical isolation	
Channel - PLC	Yes
Channel - Channel	No
Group isolation	Input group - Output group
Power consumption	0.5 W
Certification	CE, C-UL-US, GOST-R
Mechanical characteristics	7DM435.7
Dimensions	System 2003 single-width
Protection type	IP20
Operating temperature	
Horizontal installation	0°C to +60°C
Vertical installation	0°C to +50°C
Storage temperature	-25°C to +70°C
Relative humidity	5 to 95%, non-condensing
Comment	3 x TB710 terminal block separately

Required accessories

7TB710.9	Accessory terminal block, 10-pin, screw clamp, 1.5 mm ²
7TB710.91	Accessory terminal block, 10 pin, cage clamp, 2.5 mm ²

Optional accessories

7TB722.9	System 2003 terminal block, 22-pin, screw clamps	110
7TB722.91	System 2003 terminal block, 22-pin, cage clamps	110
7TB733.9	System 2003 terminal block, 33-pin, screw clamps	110
7TB733.91	System 2003 terminal block, 33-pin, cage clamps	110

Digital mixed module DM438



Digital input/output module with 8 channels, 24 VDC.

- DSUB connector for I/O connection

Short description	7DM438.72
I/O module	8 digital inputs, 8 digital outputs
Digital inputs	7DM438.72
Rated voltage	24 VDC
Input filter	
Hardware	≤1 ms
Software	-
Input circuit	Sink or source
Digital outputs	7DM438.72
Rated voltage	24 VDC
Rated output current	0.5 A
Total current	4.0 A
Output circuit	Source
Output protection	Thermal cutoff for overcurrent or short circuit, integrated protection for switching inductances, reverse polarity protection for output supply
Sensor supply	External
General information	7DM438.72
Status indicators	I/O function per channel, I/O supply
Diagnostics	
Outputs	Yes, with status LED
I/O supply	Yes, with status LED and software status
Number of operable modules with	
CP430, EX270, EX290	4
CP470, CP770, CP474, CP476, CP774	8
EX470, EX770, EX481, EX484	
CP570	9
Electrical isolation	
Channel - PLC	Yes
Channel - Channel	No
Group isolation	Input group - Output group
Power consumption	0.5 W
Certification	CE, C-UL-US, GOST-R
Mechanical characteristics	7DM438.72
Dimensions	System 2003 single-width
Protection type	IP20
Operating temperature	
Horizontal installation	0°C to +60°C
Vertical installation	0°C to +50°C
Storage temperature	-25°C to +70°C
Relative humidity	5 to 95%, non-condensing
Comment	Connection made using DSUB connectors

Digital mixed module DM465



Digital input/output module with 16 channels, 24 VDC.

Short description	7DM465.7
I/O module	16 digital inputs, 16 digital outputs
Digital inputs	7DM465.7
Rated voltage	24 VDC
Input filter	
Hardware	≤1 ms
Software	-
Input circuit	Sink
Digital outputs	7DM465.7
Rated voltage	24 VDC
Rated output current	0.5 A
Total current	8.0 A
Output circuit	Source
Output protection	Thermal cutoff for overcurrent or short circuit, integrated protection for switching inductances, reverse polarity protection for output supply
Sensor supply	External
General information	7DM465.7
Status indicators	I/O function per channel, I/O supply
Diagnostics	
Outputs	Yes, with status LED
I/O supply	Yes, with status LED and software status
Number of operable modules with ¹⁾	
CP430, EX270, EX290	2
CP470, CP770, EX470, EX770	4
CP474, CP774	6
CP476, EX481, EX484	8
CP570	8
Electrical isolation	
Channel - PLC	Yes
Channel - Channel	No
Input group - Output group	No
Power consumption	1.1 W
Certification	CE, C-UL-US, GOST-R
1) Two logical module slots are required by the module.	
Mechanical characteristics	7DM465.7
Dimensions	System 2003 single-width
Protection type	IP20
Operating temperature	
Horizontal installation	0°C to +60°C
Vertical installation	0°C to +50°C
Storage temperature	-25°C to +70°C
Relative humidity	5 to 95%, non-condensing
Comment	2 x TB718 terminal block separately

Required accessories	
7TB718.9	Accessory terminal block, 18-pin, screw clamp, 1.5 mm ²
7TB718.1	Accessory terminal block, 18-pin, cage clamp, 1.5 mm ²

Optional accessories		
7TB736.9	System 2003 terminal block, 36-pin, screw clamps	111
7TB736.1	System 2003 terminal block, 36-pin, cage clamps	111
7TB754.9	System 2003 terminal block, 54-pin, screw clamps	111
7TB754.1	System 2003 terminal block, 54-pin, cage clamps	111
7TB772.1	System 2003 terminal block, 72-pin, cage clamps	112

Analog input module AI261



The AI261 analog input module is equipped with an input for evaluating a full-bridge strain gauge. A full-bridge strain gauge can be used for the following tasks:

- Force gauge
- Elasticity gauge
- Load cell
- Pressure gauge
- Strain gauge
- Torque measuring device

Short description	7AI261.7
I/O module	1 input used to evaluate a full-bridge strain gauge
Full-bridge strain gauge	7AI261.7
Measurement area	± 1 to ± 16 mV/V, set using software
Input current	<140 nA
Input type	Differential input
Digital converter resolution	24-bit
Operating range / Measurement sensor	75 to 5,000 Ω
Bridge voltage	4.5 VDC $\pm 3\%$ / max. 60 mA
Short circuit, overload protection	Yes
Connection	4-wire connection
Measurement value preparation	
Calibration	Using software, also during operation
Linearization	$y = k * x + d$
Conversion	In physical units (32-bit representation)
Basic accuracy	± 55 ppm ± 11 μ V at 25°C
Input protection	Protection against wiring with supply voltage
Sensor type	Isolated
General information	7AI261.7
Electrical isolation	
Channel - PLC	No
Power consumption	0.6 W
Certification	CE, C-UL-US, GOST-R
Mechanical characteristics	7AI261.7
Slot	Adapter module, CPU with local slots for System 2003 screw-in modules
Protection type	IP20
Operating temperature	
Horizontal installation	0°C to +60°C
Vertical installation	0°C to +50°C
Storage temperature	-25°C to +70°C
Relative humidity	5 to 95%, non-condensing
Comment	Connection made using screw clamps integrated in the module

Analog input module

AI294



The AI294 is a 4-channel analog input module. It is used to evaluate potentiometer displacement gauges.

A threshold value can be defined for any channel. The evaluation is made using the module status register.

Short description	7AI294.7
I/O module	Four inputs for potentiometer displacement gauge evaluation
Analog inputs	7AI294.7
Potentiometer supply voltage U_{pot}	+4.5 V \pm 3% at 40 mA
Short circuit and overload protection	Yes
Input type	Single ended input ranging from 0 V to U_{pot}
Digital converter resolution	13-bit
Conversion time	4 ms for all channels, also with active comparator
Measurement sensor	0.5 to 10 k Ω , potentiometer
Measurement area	0 V to U_{pot}
Output format	INT
Basic accuracy	\pm 0.1% of full range at 25°C
Input protection	Protection against wiring with supply voltage
General information	7AI294.7
Electrical isolation	
Channel - PLC	No
Power consumption	0.5 W
Certification	CE, C-UL-US, GOST-R
Mechanical characteristics	7AI294.7
Slot	Adapter module, CPU with local slots for System 2003 screw-in modules
Protection type	IP20
Operating temperature	
Horizontal installation	0°C to +60°C
Vertical installation	0°C to +50°C
Storage temperature	-25°C to +70°C
Relative humidity	5 to 95%, non-condensing
Comment	Connection made using screw clamps integrated in the module

Analog input module AI351



One-channel analog input module,
 ± 10 V or 0 to 20 mA.

Short description	7AI351.70
I/O module	1 analog input ± 10 V or 0 to 20 mA, potentiometer supply
Analog inputs	7AI351.70
Input	± 10 V or 0 to 20 mA (also ± 20 mA), can be configured using switch
Input type	Differential input
Digital converter resolution	12-bit + sign
Output format	INT
Input impedance in signal range	
Voltage	20 M Ω
Current (load)	130 - 200 Ω
Basic accuracy at 25°C	
Offset	
Voltage	Max. ± 2.5 mV
Current	Max. ± 5 μ A
Gain	Max. 0.1% of final value
Linearity error	Max. 0.05% of final value
Input protection	Protection against wiring with supply voltage
Potentiometer supply	7AI351.70
Voltage	± 9.94 V
Load	≥ 2 k Ω , max. 10 mA
Short circuit protection	Yes
Basic accuracy	Max. ± 9.94 V $+2.3\%$ / -1.7% at 25 °C
General information	7AI351.70
Electrical isolation	
Channel - PLC	No
Power consumption	
Current/Voltage measurement	0.3 W
Potentiometer operation	0.7 W
Certification	CE, C-UL-US, GOST-R
Mechanical characteristics	7AI351.70
Slot	Adapter module, CPU with local slots for System 2003 screw-in modules
Protection type	IP20
Operating temperature	
Horizontal installation	0°C to +60°C
Vertical installation	0°C to +50°C
Storage temperature	-25°C to +70°C
Relative humidity	5 to 95%, non-condensing
Comment	1 x TB712 terminal block separately

Required accessories	
7TB712.9	Accessory terminal block, 12-pin, screw clamp, 1.5 mm ²
7TB712.91	Accessory terminal block, 12-pin, cage clamp, 1.5 mm ²

Analog input module

AI354



Four-channel analog input module,
±10 V

Short description	7AI354.70
I/O module	4 analog inputs ±10 V
Analog inputs	7AI354.70
Input	±10 V
Input type	Differential input
Digital converter resolution	12-bit + sign
Output format	INT
Input impedance in signal range	20 MΩ
Basic accuracy at 25°C	
Offset	Max. ±2.5 mV
Gain	Max. 0.1% of final value
Linearity error	Max. 0.1% of final value
Input protection	Protection against wiring with supply voltage
General information	7AI354.70
Electrical isolation	
Channel - PLC	No
Channel - Channel	No
Power consumption	0.5 W
Certification	CE, C-UL-US, GOST-R
Mechanical characteristics	7AI354.70
Slot	Adapter module, CPU with local slots for System 2003 screw-in modules
Protection type	IP20
Operating temperature	
Horizontal installation	0°C to +60°C
Vertical installation	0°C to +50°C
Storage temperature	-25°C to +70°C
Relative humidity	5 to 95%, non-condensing
Comment	1 x TB712 terminal block separately

Required accessories	
7TB712.9	Accessory terminal block, 12-pin, screw clamp, 1.5 mm ²
7TB712.91	Accessory terminal block, 12-pin, cage clamp, 1.5 mm ²

Analog input module AI774



Four-channel analog input module,
0 to 20 mA

Short description	7AI774.70
I/O module	4 analog inputs 0 - 20 mA
Analog inputs	7AI774.70
Input	0 - 20 mA (also ± 20 mA)
Input type	Differential input
Digital converter resolution	12-bit
Output format	INT
Load	130 - 200 Ω
Basic accuracy at 25°C	
Offset	Max. $\pm 5 \mu\text{A}$
Gain	Max. 0.05% of final value
Linearity error	Max. 0.05% of final value
Input protection	Protection against wiring with supply voltage
General information	7AI774.70
Electrical isolation	
Channel - PLC	No
Channel - Channel	No
Power consumption	0.4 W
Certification	CE, C-UL-US, GOST-R
Mechanical characteristics	7AI774.70
Slot	Adapter module, CPU with local slots for System 2003 screw-in modules
Protection type	IP20
Operating temperature	
Horizontal installation	0°C to +60°C
Vertical installation	0°C to +50°C
Storage temperature	-25°C to +70°C
Relative humidity	5 to 95%, non-condensing
Comment	1 x TB712 terminal block separately

Required accessories	
7TB712.9	Accessory terminal block, 12-pin, screw clamp, 1.5 mm ²
7TB712.91	Accessory terminal block, 12-pin, cage clamp, 1.5 mm ²

Analog output module AO352



Two-channel analog output module,
 ± 10 V or 0 to 20 mA.

Short description	7AO352.70
I/O module	2 analog outputs, ± 10 V or 0 to 20 mA
Analog outputs	7AO352.70
Output	Current or voltage can be set for each channel using a switch
Digital converter resolution	12-bit
Output protection	Protection against wiring with supply voltage, short circuit protection
Current Output	7AO352.70
Current	0 to 20 mA
Load	Max. 400 Ω
Basic accuracy at 25°C	At 50 Ω load
Offset	Max. ± 5.3 μ A
Gain	Max. $\pm 0.06\%$
Linearity error	Max. $\pm 0.13\%$ of final value
Voltage output	7AO352.70
Voltage	± 10 V
Load	Max. 10 mA
Basic accuracy at 25°C	At 10 k Ω load
Offset	Max. ± 5.2 mV
Gain	Max. $\pm 0.3\%$
Linearity error	Max. $\pm 0.13\%$ of final value
General information	7AO352.70
Electrical isolation	
Channel - PLC	No
Channel - Channel	No
Power consumption	1.2 W
Certification	CE, C-UL-US, GOST-R
Mechanical characteristics	7AO352.70
Slot	Adapter module, CPU with local slots for System 2003 screw-in modules
Protection type	IP20
Operating temperature	
Horizontal installation	0°C to +60°C
Vertical installation	0°C to +50°C
Storage temperature	-25°C to +70°C
Relative humidity	5 to 95%, non-condensing
Comment	1 x TB712 terminal block separately

Required accessories	
7TB712.9	Accessory terminal block, 12-pin, screw clamp, 1.5 mm ²
7TB712.91	Accessory terminal block, 12-pin, cage clamp, 1.5 mm ²

Analog mixed module AM351



Analog input/output module each with one channel, ± 10 V.

Short description	7AM351.70
I/O module	1 analog input, 1 analog output
Analog inputs	7AM351.70
Input	± 10 V
Input type	Differential input
Digital converter resolution	16-bit
Conversion time	< 1 ms in TPU operation
Output format	INT
Input impedance in signal range	20 M Ω
Basic accuracy	$\pm 0.02\% \pm 0.9 \mu\text{V}$ at 24°C, based on the current measurement value
Input protection	Protection against wiring with supply voltage
Analog outputs	7AM351.70
Output	± 10 V
Digital converter resolution	16-bit
Conversion time	< 1 ms in TPU operation
Output protection	Protection against wiring with supply voltage, short circuit protection
Basic accuracy	$\pm 0.02\% \pm 1.2 \mu\text{V}$ at 24°C, based on the output value
General information	7AM351.70
Electrical isolation	
Channel - PLC	Yes
Channel - Channel	No
Power consumption	1.4 W
Certification	CE, C-UL-US, GOST-R
Mechanical characteristics	7AM351.70
Slot	Adapter module, CPU with local slots for System 2003 screw-in modules
Protection type	IP20
Operating temperature	
Horizontal installation	0°C to +60°C
Vertical installation	0°C to +50°C
Storage temperature	-25°C to +70°C
Relative humidity	5 to 95%, non-condensing
Comment	1 x TB712 terminal block separately

Required accessories	
7TB712.9	Accessory terminal block, 12-pin, screw clamp, 1.5 mm ²
7TB712.91	Accessory terminal block, 12-pin, cage clamp, 1.5 mm ²

Temperature module AT324



The AT324 screw-in module is equipped with four input channels. It is used to evaluate measured values for PT100, PT1000, KTY10-6 and KTY84-130 temperature sensors.

Short description	7AT324.70
I/O module	4 inputs for resistance measurement
Temperature input resistance meas.	7AT324.70
Input	Resistance measurement with constant current supply for 2-line
Digital converter resolution	16-bit
Conversion time	
Same sensor types	60 ms per channel
When switching sensor type	190 ms per channel
Output format	INT or UINT for resistance measurement
Basic accuracy	±0.1% at 25°C, based on the measurement range
Input protection	Protection against wiring with supply voltage
Sensor	
KTY10-6	-50°C to +150°C
KTY84-130	-40°C to +300°C
PT100	-200°C to +850°C
PT1000	-200°C to +850°C
Resistance measurement range	1 to 4995 Ω / 1 to 2497.5 Ω
General information	7AT324.70
Electrical isolation	
Channel - PLC	No
Channel - Channel	No
Power consumption	0.1 W
Certification	CE, C-UL-US, GOST-R
Mechanical characteristics	7AT324.70
Slot	Adapter module, CPU with local slots for System 2003 screw-in modules
Protection type	IP20
Operating temperature	
Horizontal installation	0°C to +60°C
Vertical installation	0°C to +50°C
Storage temperature	-25°C to +70°C
Relative humidity	5 to 95%, non-condensing
Comment	1 x TB712 terminal block separately

Required accessories	
7TB712.9	Accessory terminal block, 12-pin, screw clamp, 1.5 mm ²
7TB712.91	Accessory terminal block, 12-pin, cage clamp, 1.5 mm ²

Temperature module AT352



The AT352 screw-in module is equipped with two input channels. It is used to evaluate measured values for PT100 temperature sensors.

Short description	7AT352.70
I/O module	2 inputs for PT100 resistance measurement
Temperature input resistance meas.	7AT352.70
Input	Resistance measurement for 3 wires
Digital converter resolution	16-bit
Conversion time	
50 Hz filter	20 ms for all channels
60 Hz filter	16.67 ms for all channels
Output format	INT
Basic accuracy	$\pm(0.17 + 0.0005 * T_F)$ [°C] at 25°C, T _F ... Sensor temperature in °C
Input protection	Protection against wiring with supply voltage
Measurement area	
Small measurement range	-200.00 to +327.67°C, resolution 0.01°C
Large measurement range	-200.0 to +850.0°C, resolution 0.1°C
General information	7AT352.70
Electrical isolation	
Channel - PLC	No
Channel - Channel	No
Power consumption	0.4 W
Certification	CE, C-UL-US, GOST-R
Mechanical characteristics	7AT352.70
Slot	Adapter module, CPU with local slots for System 2003 screw-in modules
Protection type	IP20
Operating temperature	
Horizontal installation	0°C to +60°C
Vertical installation	0°C to +50°C
Storage temperature	-25°C to +70°C
Relative humidity	5 to 95%, non-condensing
Comment	1 x TB712 terminal block separately

Required accessories	
7TB712.9	Accessory terminal block, 12-pin, screw clamp, 1.5 mm ²
7TB712.91	Accessory terminal block, 12-pin, cage clamp, 1.5 mm ²

Temperature module AT664



The AT664 analog input module scans the inputs with a constant cycle time. Each module can be individually set to a certain sensor type. Automatic thermocouple calculation and raw value measurement can be combined without limitations.

Short description	7AT664.70
I/O module	4 inputs for thermocouples
Thermocouple temperature inputs	7AT664.70
Input	Thermocouple
Digital converter resolution	16-bit
Output format	INT
Basic accuracy	$\pm(50 \mu\text{V} + 0.001 * U_{\text{TH}})$ [μV] at 25°C, U_{TH} ... Thermal voltage in μV
Input protection	Protection against wiring with supply voltage
Measurement area	
Sensor temperature	
FeCuNi: Type J	-210 to +1200°C
NiCrNi: Type K	-270 to +1372°C
PtRhPt: Type S	-50 to +1768°C
Terminal temperature	-55 to +125°C
Raw value	$\pm 65,534 \mu\text{V}$
Terminal temperature compensation	Can be configured using software
General information	7AT664.70
Electrical isolation	
Channel - PLC	No
Channel - Channel	No
Power consumption	0.4 W
Certification	CE, C-UL-US, GOST-R
Mechanical characteristics	7AT664.70
Slot	Adapter module, CPU with local slots for System 2003 screw-in modules
Protection type	IP20
Operating temperature	
Horizontal installation	0°C to +60°C
Vertical installation	0°C to +50°C
Storage temperature	-25°C to +70°C
Relative humidity	5 to 95%, non-condensing
Comment	1 x TB712 terminal block separately

Required accessories	
7TB712.9	Accessory terminal block, 12-pin, screw clamp, 1.5 mm ²
7TB712.91	Accessory terminal block, 12-pin, cage clamp, 1.5 mm ²

Combination module CM211



Universal input/output module with 8 digital inputs, 8 digital outputs, 2 analog inputs, 2 analog outputs and special functions.

Short description	7CM211.7
I/O module	8 digital inputs, 8 digital outputs, 2 analog inputs, 2 analog outputs, special functions
Digital inputs	7CM211.7
Number of channels	8
Rated voltage	24 VDC
Input filter	
Hardware	$\leq 10 \mu\text{s}$
Software	0 or 4 ms (default)
Input circuit	Sink
Additional functionalities for inputs	3 x event counters, 3 x period measurement, 3 x gate measurement, 2 x ABR incremental encoder (+24 V)
Incremental encoder operation	7CM211.7
Number	2
Counter size	32-bit
Input frequency	20 kHz
Evaluation	4-fold, cyclic counter
Signal form	Square wave pulse
Event counter operation	7CM211.7
Number	3
Counter size	16-bit
Input frequency	20 kHz
Evaluation	Each edge, cyclic counter
Signal form	Square wave pulse
Period measurement	7CM211.7
Number	3
Counter size	16-bit
Input frequency	20 kHz
Evaluation	Positive edge - Positive edge
Count frequency	
Internal	16 MHz, 4 MHz, 1 MHz, 250 kHz
External	Max. 20 kHz
Signal form	Square wave pulse
Gate measurement	7CM211.7
Number	3
Counter size	16-bit
Input frequency	10 kHz
Evaluation	Positive edge - Negative edge
Count frequency	
Internal	16 MHz, 4 MHz, 1 MHz, 250 kHz
External	Max. 20 kHz
Gate pause	50 μs
Signal form	Square wave pulse
Digital outputs	7CM211.7
Number of channels	8
Rated voltage	24 VDC
Rated output current	0.5 A
Total current	4.0 A
Output circuit	Source
Output protection	Thermal cutoff for overcurrent or short circuit, integrated protection for switching inductances, reverse polarity protection for output supply
Additional functionalities for outputs	2 comparator outputs, reaction time $< 500 \mu\text{s}$ and $< 2 \text{ ms}$
Sensor supply	External

Analog inputs		7CM211.7
Number of channels		2
Input		±10 V / 0 - 20 mA, can be set for each channel with switch
Input type		Asymmetric
Digital converter resolution		12-bit
Conversion time		<4 ms for both channels, the channels are converted cyclically
Output format		INT
Input impedance in signal range for		
Voltage input		> 1 MΩ
Current input (load)		95 - 200 Ω
Basic accuracy at 25°C		
Offset		Voltage: ±2.62 mV / current: ±5.29 μA
Gain		±0.2% based on the maximum positive final value
Input protection		Protection against wiring with supply voltage
Analog outputs		7CM211.7
Number of channels		2
Output		±10 V
Digital converter resolution		12-bit
Conversion time		<4 ms for both channels
Basic accuracy at 25°C		
Offset		±5.14 mV
Gain		±0.2% based on the maximum positive final value
Output protection		Protection against wiring with supply voltage, short circuit protection
General information		7CM211.7
Status indicators		I/O function per digital channel, I/O supply
Diagnostics		
Digital outputs		Yes, with status LED
I/O supply		Yes, with status LED and software status
Number of operable modules with ¹⁾		
EX270		1
CP430, EX290, EX470, EX770		2
CP470, CP770, CP474, CP476, CP774		4
EX481, EX484:		
CP570		8, note derating
Electrical isolation		No
Power consumption		1.5 W
Certification		CE, C-UL-US, GOST-R
1) Two logical module slots are required by the module.		
Mechanical characteristics		7CM211.7
Dimensions		System 2003 single-width
Protection type		IP20
Operating temperature		
Horizontal installation		0°C to +60°C
Vertical installation		0°C to +50°C
Storage temperature		-25°C to +70°C
Relative humidity		5 to 95%, non-condensing
Comment		2 x TB718 terminal block separately

21

Required accessories	
7TB718.9	Accessory terminal block, 18-pin, screw clamp, 1.5 mm ²
7TB718.91	Accessory terminal block, 18-pin, cage clamp, 1.5 mm ²
Optional accessories	
7TB736.9	System 2003 terminal block, 36-pin, screw clamps
7TB736.91	System 2003 terminal block, 36-pin, cage clamps
7TB754.9	System 2003 terminal block, 54-pin, screw clamps
7TB754.91	System 2003 terminal block, 54-pin, cage clamps

Combination module CM411



Universal input/output module with 3 digital inputs, 2 digital outputs, 3 analog inputs, 3 analog outputs and special functions.

Short description	7CM411.70-1
I/O module	3 digital inputs, 2 digital outputs, 3 analog inputs, 3 analog outputs, special functions
Digital inputs	7CM411.70-1
Number of channels	3
Rated voltage	24 VDC
Input filter	
Hardware	$\leq 3 \mu\text{s}$
Software	-
Input circuit	Sink
Additional functionalities for inputs	2 x event counters, 1 x incremental encoder ABR (+24 V)
Incremental encoder operation	7CM411.70-1
Number	1
Counter size	32-bit
Input frequency	50 kHz
Evaluation	4-fold, cyclic counter
Signal form	Square wave pulse
Event counter operation	7CM411.70-1
Number	2
Counter size	16-bit
Input frequency	50 kHz
Evaluation	Each edge, cyclic counters
Signal form	Square wave pulse
Digital outputs	7CM411.70-1
Number of channels	2
Rated voltage	24 VDC
Rated output current	0.5 A
Total current	1.0 A
Output circuit	Source
Output protection	Thermal cutoff for overcurrent or short circuit, integrated protection for switching inductances, reverse polarity protection for output supply
Additional functionalities for outputs	1 fast comparator output, reaction time $< 100 \mu\text{s}$
Sensor supply	External
Analog inputs	7CM411.70-1
Number of channels	3
Input	$\pm 10 \text{ V}$
Input type	Differential input
Digital converter resolution	16-bit
Output format	INT
Input impedance in signal range	10 M Ω
Basic accuracy	$\pm 0.1\%$ at 25°C, based on the measurement range
Input protection	Protection against wiring with supply voltage
Analog outputs	7CM411.70-1
Number of channels	3
Output	$\pm 10 \text{ V}$
Digital converter resolution	16-bit
Output protection	Protection against wiring with supply voltage, short circuit protection
Basic accuracy	$\pm 0.1\%$ at 25°C, based on the output range

General information		7CM411.70-1
Status indicators	I/O function per digital channel, I/O supply	
Diagnostics		
Digital outputs	Yes, with status LED	
I/O supply	Yes, with status LED and software status	
Number of operable modules with ¹⁾		
CP430, EX270, EX290	1	
CP470, CP770, CP474, CP476, CP774	2	
EX470, EX770, EX481, EX484		
CP570	6 ²⁾ , note derating	21
Electrical isolation		
Analog - PLC	No	
Digital - PLC	Yes	
Digital - Analog	Yes	
Channel - Channel	No	
Power consumption	2.4 W	
Certification	CE, C-UL-US, GOST-R	

1) Two logical module slots are required by the module.

2) Without aPCI interface module

Mechanical characteristics		7CM411.70-1
Dimensions	System 2003 single-width	
Protection type	IP20	
Operating temperature		
Horizontal installation	0°C to +60°C	
Vertical installation	0°C to +50°C	
Storage temperature	-25°C to +70°C	
Relative humidity	5 to 95%, non-condensing	
Comment	3 x TB710 terminal block separately	

Required accessories	
7TB710.9	Accessory terminal block, 10-pin, screw clamp, 1.5 mm ²
7TB710.91	Accessory terminal block, 10 pin, cage clamp, 2.5 mm ²

Motor module MM424

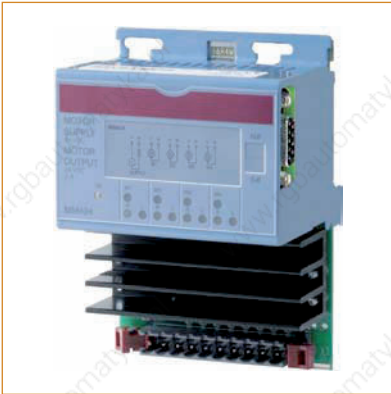

The MM424 motor module is used for digital control of up to four DC motors with a nominal voltage of 24 VDC at a nominal current of max. 2 A. The following possibilities are available for the motor:

- Switch through 24 VDC:
Motor is running
- Change polarity of plus and minus:
Motor changes direction
- Plus and minus open:
Motor freewheeling or spins out
- Plus and minus connected:
Motor brakes itself

To increase the nominal current, outputs can be switched in parallel. The module is controlled digitally.

The motor module is mainly used for motor-drive combinations with or without a slip friction clutch. Any 24 VDC motor can be used if the specified currents are met. The module does not have an integrated brake resistor, which means that generator operation of a motor can cause the supply voltage to increase excessively. Therefore, this type of operation must be prevented mechanically. The module is optimally suited for use as a very compact alternative to four reversing motor starter combinations in this performance range, especially for decentralized operation.

Short description	7MM424.70-1
I/O module	4 digital output levels for control of DC motors with 24 VDC
Digital output levels	7MM424.70-1
Type	Push-Pull
Rated voltage	24 VDC
Rated output current	3.0 A
Total current	8.0 A, to increase the output current, bridges can be switched in parallel.
Maximum current	5 A @ ≤200 ms
Starting current	10 A @ ≤50 ms
Output protection	Thermal cutoff for overcurrent or short circuit, integrated protection for switching inductances
Sensor supply	External
General information	7MM424.70-1
Status indicators	Bridge status, I/O function per channel, I/O supply
Diagnostics	
Bridge status	Yes, with status LED and software status
Digital outputs	Yes, with status LED
I/O supply	Yes, with status LED and software status
Number of operable modules with	
CP430, EX270, EX290	4
CP470, CP770, CP474, CP476, CP774	8
EX470, EX770, EX481, EX484	
CP570	9
Electrical isolation	
Bridge - PLC	Yes
Bridge - Bridge	No
Power consumption	
Internal	0.5 W
External 24 VDC	6.1 W
Certification	CE, C-UL-US, GOST-R
Mechanical characteristics	7MM424.70-1
Dimensions	System 2003 single-width
Protection type	IP20
Operating temperature	
Horizontal installation	0°C to +50°C
Vertical installation	TBD
Storage temperature	-25°C to +70°C
Relative humidity	5 to 95%, non-condensing
Comment	1 x TB710 terminal block separately

Required accessories	
7TB710.9	Accessory terminal block, 10-pin, screw clamp, 1.5 mm ²
7TB710.91	Accessory terminal block, 10 pin, cage clamp, 2.5 mm ²

Motor bridge module MM432



The motor bridge module MM432 is used to control two DC motors with a nominal voltage of 10 - 24 VDC at a nominal current up to 4 A. The module is also equipped with two ABR channels as well as six digital inputs for creating simple positioning tasks.

Each motor is controlled with a full-bridge (H-bridge). Therefore the motors can be moved in both directions. Each bridge branch has its own supply voltage. The advantage of this is that two different motors with different voltages can be used. Each channel has current measurement, supply voltage measurement, and short circuit recognition to ground and to the positive supply voltage. Noise-free motor control takes place using a 16 kHz PWM signal.

A local processor handles communication, ABR and digital input processing, the control of both motors each with a PWM signal and analog measurements.

Short description	7MM432.70-1
I/O module	2 full-bridge (H-bridges) for controlling DC motors (10 - 24 VDC)
Digital inputs	7MM432.70-1
Number of channels	6
Rated voltage	24 VDC
Input filter hardware	≤1 ms
Input circuit	Sink
ABR inputs	7MM432.70-1
Number of channels	6 for 2 ABR incremental encoders
Rated voltage	24 VDC
Input frequency	20 kHz
Evaluation	4x
Input circuit	Sink
Motor bridge - power element	7MM432.70-1
Number	2
Supply voltage	10 - 30 VDC
Max. overvoltage	35 VDC
Rated current	4.0 A
Maximum current (electrically limited)	8.0 A (max. 2 s)
PWM frequency	16 kHz
Output protection	Thermal cutoff for short circuit, integrated protection for switching inductances, overcurrent warning from the application program
Motor bridge - current measurement	7MM432.70-1
Number	2
Measurement area	-0.1 to +8.0 A
Resolution	50 mA
General information	7MM432.70-1
Status indicators	Bridge status, I/O function per input, I/O supply for inputs
Diagnostics	
Bridge status	Yes, with status LED and software status
I/O supply of inputs	Yes, with status LED and software status
Number of operable modules with	
EX270, EX290	1
CP430, EX470, EX770	2
CP470, CP770, CP474, CP476, CP774	4
EX481, EX484:	
CP570	6 (without aPCI interface module), note derating 21
Electrical isolation	No
Power consumption	2.5 W
Certification	CE, C-UL-US, GOST-R
Mechanical characteristics	7MM432.70-1
Dimensions	System 2003 single-width
Protection type	IP20
Operating temperature	0°C to +55°C (horizontal mounting orientation)
Storage temperature	-25°C to +70°C
Relative humidity	5 to 95%, non-condensing
Comment	1 x TB710 and 1 x TB718 terminal block separately

Required accessories	
7TB710.9	Accessory terminal block, 10-pin, screw clamp, 1.5 mm ²
7TB710.91	Accessory terminal block, 10 pin, cage clamp, 2.5 mm ²
7TB718.9	Accessory terminal block, 18-pin, screw clamp, 1.5 mm ²
7TB718.91	Accessory terminal block, 18-pin, cage clamp, 1.5 mm ²

Interface module IF311



RS232 interface module

Short description	7IF311.7
Communication module	1 x RS232
Interfaces	7IF311.7
Interface IF1	
Type	RS232
Design	9-pin DSUB plug
Maximum transfer rate	115.2 kBit/s
General information	7IF311.7
Electrical isolation	
PLC - IF1	No
Power consumption	
	0.5 W
	2.3 W with P126 ¹⁾
Certification	CE, C-UL-US, GOST-R
1) Integrated power supply on pin 4 of the RS232 interface for simple Panelware controllers, e.g. P126	
Mechanical characteristics	7IF311.7
Slot	CPU with local slots for B&R 2003 screw-in modules, slots 1, 2 and 3
Protection type	
	IP20
Operating temperature	
Horizontal installation	0°C to +60°C
Vertical installation	0°C to +50°C
Storage temperature	
	-25°C to +70°C
Relative humidity	
	5 to 95%, non-condensing

Optional accessories	
0G0001.00-090	Cable PC <-> PLC/PW, RS232, online cable

Interface module IF321



RS485/RS422 interface module

Short description	7IF321.7
Communication module	1 x RS485/RS422
Interfaces	7IF321.7
Interface IF1	
Type	RS485/RS422
Design	9-pin DSUB socket
Maximum transfer rate	115.2 kBit/s
General information	7IF321.7
Electrical isolation	
PLC - IF1	Yes
Power consumption	1.4 W
Certification	CE, C-UL-US, GOST-R
Mechanical characteristics	7IF321.7
Slot	CPU with local slots for B&R 2003 screw-in modules, slots 1, 2 and 3
Protection type	IP20
Operating temperature	
Horizontal installation	0°C to +60°C
Vertical installation	0°C to +50°C
Storage temperature	-25°C to +70°C
Relative humidity	5 to 95%, non-condensing

Interface module IF361



Profibus DP interface module



Short description	7IF361.70-1
Communication module	Profibus DP slave
Interfaces	7IF361.70-1
Interface IF1	
Fieldbus	Profibus DP slave
Type	RS485
Design	9-pin DSUB socket
Maximum transfer rate	12 MBit/s
General information	7IF361.70-1
Status indicators	Data being sent/received
Diagnostics	
Data transfer	Yes, with status LED
Electrical isolation	
PLC - IF1	Yes
Power consumption	2.6 W
Certification	CE, C-UL-US, GOST-R
Mechanical characteristics	7IF361.70-1
Slot	CPU with local slots for B&R 2003 screw-in modules, slots 1, 2 and 3
Protection type	IP20
Operating temperature	
Horizontal installation	0°C to +60°C
Vertical installation	0°C to +50°C
Storage temperature	-25°C to +70°C
Relative humidity	5 to 95%, non-condensing

Interface module IF613



- Triple RS232 interface module
- RS232 configurable as an online interface

Short description	3IF613.9
Communication module	3 x RS232
Interfaces	3IF613.9
Interfaces IF1 - IF3	
Type	RS232
Design	9-pin DSUB plug
Maximum transfer rate	115.2 kBit/s
General information	3IF613.9
Status indicators	Send/receive data via interface
Diagnostics	
Data transfer	Yes, with status LED
Electrical isolation	
PLC - IFx	No
IFx - IFx	No
Power consumption	
5 V	1.2 W
24 V	-
Total	1.2 W
Certification	CE, C-UL-US, GOST-R
Mechanical characteristics	3IF613.9
Slot	Insert for CP260, IF260, IF060
Protection type	IP20
Operating / Storage temperature	0°C to +60°C / -25°C to +70°C
Relative humidity	5 to 95%, non-condensing

Optional accessories	
OG0001.00-090	Cable PC <-> PLC/PW, RS232, online cable

Interface module IF621



- Combination module with CAN and RS485/RS422
- RS485/RS422 custom programming

CAN

Short description	3IF621.9
Communication module	1 x RS485/RS422, 1 x CAN
Interfaces	3IF621.9
Interface IF1	
Type	RS485/RS422
Design	9-pin DSUB socket
Maximum transfer rate	115.2 kBit/s
Interface IF2	
Type	CAN
Design	4-pin multipoint connector
Maximum transfer rate	500 kBit/s
General information	
Status indicators	Send/receive data via interface
Diagnostics	
Data transfer	Yes, with status LED
Electrical isolation	
PLC - IF1/IF2	Yes
IF1 - IF2	Yes
Power consumption	
5 V	1.5 W
24 V	-
Total	1.5 W
Certification	CE, C-UL-US, GOST-R
Mechanical characteristics	
Slot	Insert for CP260, IF260, IF060
Protection type	IP20
Operating / Storage temperature	0°C to +60°C / -25°C to +70°C
Relative humidity	5 to 95%, non-condensing

Optional accessories	
0AC913.93	Bus adapter, CAN, 2 CAN interfaces, including 30 cm connection cable (TB704)
0G1000.00-090	Bus connector, RS485, for Profibus networks

Interface module IF622



- Serial multi-interface module with RS232 and double RS485/RS422
- RS232 can be configured as an online interface

Short description	3IF622.9
Communication module	1 x RS232, 2 x RS485/RS422
Interfaces	3IF622.9
Interface IF1	
Type	RS232
Design	9-pin DSUB plug
Maximum transfer rate	115.2 kBit/s
Interfaces IF2 and IF3	
Type	RS485/RS422
Design	9-pin DSUB socket
Maximum transfer rate	115.2 kBit/s
General information	3IF622.9
Status indicators	Send/receive data via interface
Diagnostics	
Data transfer	Yes, with status LED
Electrical isolation	
PLC - IF1	No
PLC - IF2/IF3	Yes
IF1 - IF2/IF3	Yes
IF2 - IF3	Yes
Power consumption	
5 V	1.8 W
24 V	-
Total	1.8 W
Certification	CE, C-UL-US, GOST-R
Mechanical characteristics	3IF622.9
Slot	Insert for CP260, IF260, IF060
Protection type	IP20
Operating / Storage temperature	0°C to +60°C / -25°C to +70°C
Relative humidity	5 to 95%, non-condensing

Optional accessories	
0G0001.00-090	Cable PC <-> PLC/PW, RS232, online cable
0G1000.00-090 ¹⁾	Bus connector, RS485, for Profibus networks

1) Only one bus plug can be connected on the module.

Interface module IF661



- Profibus DP slave interface



Short description	3IF661.9
Communication module	Profibus DP slave
Interfaces	3IF661.9
Interface IF1	
Fieldbus	Profibus DP slave
Type	RS485
Design	9-pin DSUB socket
Maximum transfer rate	12 MBit/s
General information	3IF661.9
Status indicators	Data being sent/received
Diagnostics	
Data transfer	Yes, with status LED
Electrical isolation	
PLC - IF1	Yes
Power consumption	
5 V	2.0 W
24 V	-
Total	2.0 W
Certification	CE, C-UL-US, GOST-R
Mechanical characteristics	3IF661.9
Slot	Insert for CP260, IF260, IF060
Protection type	IP20
Operating / Storage temperature	0°C to +60°C / -25°C to +70°C
Relative humidity	5 to 95%, non-condensing

Optional accessories	
OG1000.00-090	Bus connector, RS485, for Profibus networks

Interface module IF671



- Multi-interface module with CAN, RS232, 2 x RS485/RS422
- RS232 can be configured as an online interface

CAN

Short description	3IF671.9
Communication module	1 x RS232, 1 x RS485/RS422, 1 x CAN
Interfaces	3IF671.9
Interface IF1	
Type	RS232
Design	9-pin DSUB plug
Maximum transfer rate	115.2 kBit/s
Interface IF2	
Type	RS485/RS422
Design	9-pin DSUB socket
Maximum transfer rate	115.2 kBit/s
Interface IF3	
Type	CAN
Design	4-pin multipoint connector
Maximum transfer rate	500 kBit/s
General information	3IF671.9
Status indicators	Send/receive data via interface
Diagnostics	
Data transfer	Yes, with status LED
Electrical isolation	
PLC - IF1	No
PLC - IF2/IF3	Yes
IF1 - IF2/IF3	Yes
IF2 - IF3	Yes
Power consumption	
5 V	2.0 W
24 V	-
Total	2.0 W
Certification	CE, C-UL-US, GOST-R
Mechanical characteristics	3IF671.9
Slot	Insert for CP260, IF260, IF060
Protection type	IP20
Operating / Storage temperature	0°C to +60°C / -25°C to +70°C
Relative humidity	5 to 95%, non-condensing

Optional accessories	
0AC913.93	Bus adapter, CAN, 2 CAN interfaces, including 30 cm connection cable (TB704)
0G0001.00-090	Cable PC <-> PLC/PW, RS232, online cable
0G1000.00-090	Bus connector, RS485, for Profibus networks

Interface module IF672



- Dual CAN connection
- RS232 can be configured as an online interface

CAN

Short description	3IF672.9
Communication module	1 x RS232, 2 x CAN
Interfaces	3IF672.9
Interface IF1	
Type	RS232
Design	9-pin DSUB plug
Maximum transfer rate	115.2 kBit/s
Interfaces IF2 and IF3	
Type	CAN
Design	2 x 4-pin multipoint connector
Maximum transfer rate	500 kBit/s
General information	3IF672.9
Status indicators	Send/receive data for IF1, send data for IF2 and IF3
Diagnostics	
Data transfer	Yes, with status LED
Electrical isolation	
PLC - IF1	No
PLC - IF2/IF3	Yes
IF1 - IF2/IF3	Yes
IF2 - IF3	Yes
Power consumption	
5 V	1.8 W
24 V	-
Total	1.8 W
Certification	CE, C-UL-US, GOST-R
Mechanical characteristics	3IF672.9
Slot	Insert for CP260, IF260, IF060
Protection type	IP20
Operating / Storage temperature	0°C to +60°C / -25°C to +70°C
Relative humidity	5 to 95%, non-condensing

Optional accessories	
0AC913.93	Bus adapter, CAN, 2 CAN interfaces, including 30 cm connection cable (TB704)
0G0001.00-090	Cable PC <-> PLC/PW, RS232, online cable

Interface module IF681.86



- Ethernet interface 10 MBit/s with RJ45 connection
- RS232 can be configured as an online interface

Short description	3IF681.86
Communication module	1 x RS232, 1 x Ethernet
Interfaces	3IF681.86
Interface IF1	
Type	RS232
Design	9-pin DSUB plug
Maximum transfer rate	115.2 kBit/s
Interface IF2	
Type	Ethernet
Design	Shielded RJ45 port
Transfer rate	10 MBit/s
Cable length	Max. 100 m between two stations (segment length)
General information	3IF681.86
Status indicators	Send/receive data for IF1
Diagnostics	
IF1 data transfer	Yes, with status LED
Electrical isolation	
PLC - IF1	No
PLC - IF2	Yes
IF1 - IF2	Yes
Power consumption	
5 V	1.65 W
24 V	-
Total	1.65 W
Certification	CE, C-UL-US, GOST-R
Mechanical characteristics	3IF681.86
Slot	Insert for CP260, IF260
Protection type	IP20
Operating / Storage temperature	0°C to +60°C / -25°C to +70°C
Relative humidity	5 to 95%, non-condensing
Comment	Replaces 3IF681.96. If needed, the new driver is available on the B&R homepage. This driver is included in the operating system starting with AR V2.37.

Optional accessories

OG0001.00-090	Cable PC <-> PLC/PW, RS232, online cable
---------------	--

Interface module IF686



- ETHERNET Powerlink to meet the highest real-time demands
- RJ45 connection
- Either managing or controlled node



Short description	3IF686.9
Communication module	1 x ETHERNET Powerlink
Interfaces	3IF686.9
Interface IF1	
Fieldbus	ETHERNET Powerlink
Type	100 Base-T (ANSI/IEEE 802.3)
Design	Shielded RJ45 port
Transfer rate	100 MBit/s
Cable length	Max. 100 m between two stations (segment length)
General information	3IF686.9
Status indicators	Status of Powerlink station, network activity, link/collision
Diagnostics	
Station status	Yes, with status LED and software status
Bus function	Yes, with status LED and software status
Electrical isolation	
PLC - IF1	Yes
Power consumption	
5 V	1.76 W
24 V	-
Total	1.76 W
Certification	CE, C-UL-US, GOST-R
Mechanical characteristics	3IF686.9
Slot	Insert for CP260, IF260, IF060
Protection type	IP20
Operating / Storage temperature	0°C to +60°C / -25°C to +70°C
Relative humidity	5 to 95%, non-condensing

aPCI interface module IF722



- CAN bus connection
- RS485/RS422 on DSUB
- RS485 on multipoint connector

CAN

Short description	3IF722.9
Communication module	1 x RS485/RS422, 1 x CAN bus, 1 x RS485
Interfaces	3IF722.9
Interface IF1	
Type	RS485/RS422
Design	9-pin DSUB socket
Maximum transfer rate	115.2 kBit/s
Interface IF2	
Type	CAN bus
Design	4-pin multipoint connector
Maximum transfer rate	500 kBit/s
Interface IF3	
Type	RS485
Design	4-pin multipoint connector
Maximum transfer rate	115.2 kBit/s
General information	3IF722.9
Status indicators	
	2 LEDs for sending/receiving data for IF1
	1 LED each for sending data for IF2 and IF3
Diagnostics	
Data transfer	Yes, with status LEDs
Electrical isolation	
PLC - IFx	Yes
IFx - IFx	Yes
Power consumption	
3.3 V	0.74 W
5 V	1.0 W
Total	1.74 W
Certification	CE, C-UL-US, GHOST-R
Mechanical characteristics	3IF722.9
Slot	Insert e.g. in CP360
Protection type	IP20
Operating / Storage temperature	0°C to +60°C / -25°C to +70°C
Relative humidity	5 to 95%, non-condensing
Comment	0TB704.9 terminal block separately

Required accessories	
0TB704.9	Accessory, terminal block, 4-pin, screw clamps, 1.5 mm ²
Optional accessories	
0AC913.93	Bus adapter, CAN, 2 CAN interfaces, including 30 cm connection cable (TB704)

aPCI interface module IF761



- Profibus DP slave connection
- RS232 can be configured as an online interface



Short description	3IF761.9
Communication module	1 x RS232, 1 x Profibus DP slave
Interfaces	3IF761.9
Interface IF1	
Type	RS232
Design	9-pin DSUB plug
Maximum transfer rate	115.2 kBit/s
Interface IF2	
Fieldbus	Profibus DP slave
Type	RS485
Design	9-pin DSUB socket
Maximum transfer rate	12 MBit/s
General information	3IF761.9
Status indicators	Send/receive data via interface
Diagnostics	
Data transfer	Yes, with status LEDs
Electrical isolation	
PLC - IF1	No
PLC - IF2	Yes
IF1 - IF2	Yes
Power consumption	
3.3 V	0.15 W
5 V	1.2 W
Total	1.35 W
Certification	CE, C-UL-US, GOST-R
Mechanical characteristics	3IF761.9
Slot	Insert e.g. in CP360
Protection type	IP20
Operating / Storage temperature	0°C to +60°C / -25°C to +70°C
Relative humidity	5 to 95%, non-condensing

Optional accessories	
0G0001.00-090	Cable PC <-> PLC/PW, RS232, online cable
0G1000.00-090	Bus connector, RS485, for Profibus networks

aPCI interface module IF762



- Profibus DP slave connection
- RS485/RS422 user-specific configuration possible



Short description	3IF762.9
Communication module	1 x RS485/RS422, 1 x Profibus DP slave
Interfaces	3IF762.9
Interface IF1	
Type	RS485/RS422
Design	9-pin DSUB socket
Maximum transfer rate	115.2 kBit/s
Interface IF2	
Fieldbus	Profibus DP slave
Type	RS485
Design	9-pin DSUB socket
Maximum transfer rate	12 MBit/s
General information	3IF762.9
Status indicators	Send/receive data via interface
Diagnostics	
Data transfer	Yes, with status LEDs
Electrical isolation	
PLC - IFx	Yes
IF1 - IF2	Yes
Power consumption	
3.3 V	0.15 W
5 V	1.29 W
Total	1.44 W
Certification	CE, C-UL-US, GOST-R
Mechanical characteristics	3IF762.9
Slot	Insert e.g. in CP360
Protection type	IP20
Operating / Storage temperature	0°C to +60°C / -25°C to +70°C
Relative humidity	5 to 95%, non-condensing

Optional accessories	
0G1000.00-090	Bus connector, RS485, for Profibus networks

aPCI interface module IF766



- Profibus DP master connection
- RS232 can be used as an online interface



Short description	3IF766.9
Communication module	1 x RS232, 1 x Profibus DP master
Interfaces	3IF766.9
Interface IF1	
Type	RS232
Design	9-pin DSUB plug
Maximum transfer rate	115.2 kBit/s
Interface IF2	
Fieldbus	Profibus DP master
Number of slaves	125
Type	RS485
Design	9-pin DSUB socket
Maximum transfer rate	12 MBit/s
General information	3IF766.9
Status indicators	2 LEDs for sending/receiving data for IF1 4 LEDs for IF2 bus function
Diagnostics	
RS232 data transfer	Yes, with status LEDs
Profibus DP bus function	Yes, with status LEDs
Electrical isolation	
PLC - IF1	No
PLC - IF2	Yes
IF1 - IF2	Yes
Power consumption	
3.3 V	0.8 W
5 V	0.5 W
Total	1.3 W
Certification	CE, C-UL-US (in development), GOST-R
Mechanical characteristics	3IF766.9
Slot	Insert e.g. in CP360
Protection type	IP20
Operating / Storage temperature	0°C to +60°C / -25°C to +70°C
Relative humidity	5 to 95%, non-condensing
Comment	Order Fieldbus Configurator separately

Required accessories	
1A0550.03	B&R Fieldbus Configurator for Automation Studio versions \geq V 2.5.2
Optional accessories	
0G0001.00-090	Cable PC <-> PLC/PW, RS232, online cable
0G1000.00-090	Bus connector, RS485, for Profibus networks, remote I/O

aPCI interface module IF771



- CAN bus connection as a single interface

CAN

Short description	3IF771.9
Communication module	1 x CAN bus
Interfaces	3IF771.9
Interface IF1	
Type	CAN bus
Design	4-pin multipoint connector
Maximum transfer rate	500 kBit/s
General information	3IF771.9
Status indicators	Send/receive data for IF1
Diagnostics	
Data transfer	Yes, with status LEDs
Electrical isolation	
PLC - IF1	Yes
Power consumption	
3.3 V	0.64 W
5 V	0.66 W
Total	1.3 W
Certification	CE, GOST-R
Mechanical characteristics	3IF771.9
Slot	Insert e.g. in CP360
Protection type	IP20
Operating / Storage temperature	0°C to +60°C / -25°C to +70°C
Relative humidity	5 to 95%, non-condensing
Comment	Order Fieldbus Configurator separately

Required accessories	
0TB704.9	Accessory, terminal block, 4-pin, screw clamps, 1.5 mm ²
0TB704.91	Accessory, terminal block, 4-pin, cage clamps, 2.5 mm ²
Optional accessories	
0AC913.93	Bus adapter, CAN, 2 CAN interfaces, including 30 cm connection cable (TB704)

aPCI interface module IF772



- Dual CAN bus connection
- RS232 can be configured as an online interface

CAN

Short description	3IF772.9
Communication module	1 x RS232, 2 x CAN bus
Interfaces	3IF772.9
Interface IF1	
Type	RS232
Design	9-pin DSUB plug
Maximum transfer rate	115.2 kBit/s
Interfaces IF2 and IF3	
Type	CAN bus
Design	2 x 4-pin multipoint connector
Maximum transfer rate	500 kBit/s
General information	3IF772.9
Status indicators	2 LEDs for sending/receiving data for IF1 1 LED each for sending data for IF2 and IF3
Diagnostics	
Data transfer	Yes, with status LEDs
Electrical isolation	
PLC - IF1	No
PLC - IF2/IF3	Yes
IFx - IFx	Yes
Power consumption	
3.3 V	0.2 W
5 V	1.8 W
Total	2.0 W
Certification	CE, C-UL-US, GOST-R
Mechanical characteristics	3IF772.9
Slot	Insert e.g. in CP360
Protection type	IP20
Operating / Storage temperature	0°C to +60°C / -25°C to +70°C
Relative humidity	5 to 95%, non-condensing
Comment	OTB704.9 terminal block separately

Required accessories	
OTB704.9	Accessory, terminal block, 4-pin, screw clamps, 1.5 mm ²
Optional accessories	
0G0001.00-090	Cable PC <-> PLC/PW, RS232, online cable
0AC913.93	Bus adapter, CAN, 2 CAN interfaces, including 30 cm connection cable (TB704)

aPCI interface module IF779



- Multi-interface module
- E.g. axis applications via CAN bus
- E.g. high-speed I/O via X2X Link

CAN

Short description	3IF779.9
Communication module	1 x RS485/RS422, 1 x CAN bus, 1 x X2X Link master
Interfaces	3IF779.9
Interface IF1	
Type	RS485/RS422
Design	9-pin DSUB socket
Maximum transfer rate	115.2 kBit/s
Interface IF2	
Type	CAN bus
Design	4-pin multipoint connector
Maximum transfer rate	500 kBit/s
Interface IF3	
Type	X2X Link master
Design	4-pin multipoint connector
General information	3IF779.9
Status indicators	2 LEDs for sending/receiving data for IF1 1 LED each for sending/receiving data for IF2 and IF3
Diagnostics	
Data transfer	Yes, with status LEDs
Electrical isolation	
PLC - IFx	Yes
IFx - IFx	Yes
Power consumption	
3.3 V	0.77 W
5 V	1.74 W
Total	2.51 W
Certification	CE, GOST-R
Mechanical characteristics	3IF779.9
Slot	Insert e.g. in CP360
Protection type	IP20
Operating / Storage temperature	0°C to +60°C / -25°C to +70°C
Relative humidity	5 to 95%, non-condensing
Comment	0TB704.9 terminal block separately

Required accessories	
0TB704.9	Accessory, terminal block, 4-pin, screw clamps, 1.5 mm ²
Optional accessories	
0AC913.93	Bus adapter, CAN, 2 CAN interfaces, including 30 cm connection cable (TB704)

aPCI interface module IF781



- Ethernet 10/100 MBit/s as a single interface

Short description	3IF781.9
Communication module	1 x Ethernet
Interfaces	3IF781.9
Interface IF1	
Type	Ethernet
Design	Shielded RJ45 port
Transfer rate	10/100 MBit/s
Cable length	Max. 100 m between two stations (segment length)
General information	3IF781.9
Status indicators	Transfer rate, send/receive data
Diagnostics	
Transfer rate	Yes, with status LED
Data transfer	Yes, with status LED
Electrical isolation	
PLC - IF1	Yes
Power consumption	
3.3 V	0.66 W
5 V	-
Total	0.66 W
Certification	CE, C-UL-US, GHOST-R
Mechanical characteristics	3IF781.9
Slot	Insert e.g. in CP360
Protection type	IP20
Operating / Storage temperature	0°C to +60°C / -25°C to +70°C
Relative humidity	5 to 95%, non-condensing

aPCI interface module IF782



- ETHERNET Powerlink for real-time Ethernet communication
- RS485 on multipoint connector



Short description	3IF782.9
Communication module	1 x RS485, 1 x ETHERNET Powerlink managing or controlled node
Interfaces	3IF782.9
Interface IF1	
Type	RS485
Design	4-pin multipoint connector
Maximum transfer rate	115.2 kBit/s
Interface IF2	
Fieldbus	ETHERNET Powerlink
Type	100 Base-T (ANSI/IEEE 802.3)
Design	Shielded RJ45 port
Transfer rate	100 MBit/s
Cable length	Max. 100 m between two stations (segment length)
General information	3IF782.9
Status indicators	Send/receive data for IF1 Status of the Powerlink station, network activity, link/collision for IF2
Diagnostics	
Data transfer (IF1)	Yes, with status LEDs
Station status (IF2)	Yes, with status LED and software status
Bus function (IF2)	Yes, with status LED and software status
Electrical isolation	
PLC - IFx	Yes
IF1 - IF2	Yes
Power consumption	
3.3 V	2.5 W
5 V	0.3 W
Total	2.8 W
Certification	CE, C-UL-US, GHOST-R
Mechanical characteristics	3IF782.9
Slot	Insert e.g. in CP360
Protection type	IP20
Operating / Storage temperature	0°C to +60°C / -25°C to +70°C
Relative humidity	5 to 95%, non-condensing
Comment	1 x TB704 terminal block separately

Required accessories	
0TB704.9	Accessory, terminal block, 4-pin, screw clamps, 1.5 mm ²
0TB704.91	Accessory, terminal block, 4-pin, cage clamps, 2.5 mm ²

aPCI interface module IF786



- Multi-interface module
- ETHERNET Powerlink for real-time Ethernet communication
- RS232 can be configured as an online interface



Short description	3IF786.9
Communication module	1 x RS232, 1 x ETHERNET Powerlink managing or controlled node
Interfaces	3IF786.9
Interface IF1	
Type	RS232
Design	9-pin DSUB plug
Maximum transfer rate	115.2 kBit/s
Interface IF2	
Fieldbus	ETHERNET Powerlink
Type	100 Base-T (ANSI/IEEE 802.3)
Design	Shielded RJ45 port
Transfer rate	100 MBit/s
Cable length	Max. 100 m between two stations (segment length)
General information	3IF786.9
Status indicators	Send/receive data for IF1 Status of the Powerlink station, network activity, link/collision for IF2
Diagnostics	
Data transfer (IF1)	Yes, with status LEDs
Station status (IF2)	Yes, with status LED and software status
Bus function (IF2)	Yes, with status LED and software status
Electrical isolation	
PLC - IF1	No
PLC - IF2	Yes
IF1 - IF2	Yes
Power consumption	
3.3 V	2.0 W
5 V	0.5 W
Total	2.5 W
Certification	CE, C-UL-US, GOST-R
Mechanical characteristics	3IF786.9
Slot	Insert e.g. in CP360
Protection type	IP20
Operating / Storage temperature	0°C to +60°C / -25°C to +70°C
Relative humidity	5 to 95%, non-condensing

Optional accessories	
OG0001.00-090	Cable PC <-> PLC/PW, RS232, online cable

aPCI interface module IF787



- Interface module with CAN bus and ETHERNET Powerlink

**ETHERNET
POWERLINK**

CAN

Short description	3IF787.9
Communication module	1 x CAN bus, 1 x ETHERNET Powerlink managing or controlled node
Interfaces	3IF787.9
Interface IF1	
Type	CAN bus
Design	4-pin multipoint connector
Maximum transfer rate	500 kBit/s
Interface IF2	
Fieldbus	ETHERNET Powerlink
Type	100 Base-T (ANSI/IEEE 802.3)
Design	Shielded RJ45 port
Transfer rate	100 MBit/s
Cable length	Max. 100 m between two stations (segment length)
General information	3IF787.9
Status indicators	Send/receive data for IF1 Status of the Powerlink station, network activity, link/collision for IF2
Diagnostics	
Data transfer (IF1)	Yes, with status LED and software status
Station status (IF2)	Yes, with status LED and software status
Bus function (IF2)	Yes, with status LED and software status
Electrical isolation	
PLC - IFx	Yes
IF1 - IF2	Yes
Power consumption	
3.3 V	2.5 W
5 V	0.5 W
Total	3.0 W
Certification	CE, C-UL-US, GOST-R
Mechanical characteristics	3IF787.9
Slot	Insert e.g. in CP360
Protection type	IP20
Operating / Storage temperature	0°C to +60°C / -25°C to +70°C
Relative humidity	5 to 95%, non-condensing
Comment	1 x TB704 terminal block separately

Required accessories	
0TB704.9	Accessory, terminal block, 4-pin, screw clamps, 1.5 mm ²
0TB704.91	Accessory, terminal block, 4-pin, cage clamps, 2.5 mm ²
Optional accessories	
0AC913.93	Bus adapter, CAN, 2 CAN interfaces, including 30 cm connection cable (TB704)

aPCI interface module IF789



- ETHERNET Powerlink
- Direct connection for high-speed I/O



Short description	3IF789.9
Communication module	1 x X2X Link master, 1 x ETHERNET Powerlink managing or controlled node
Interfaces	3IF789.9
Interface IF1	
Type	X2X Link master
Design	4-pin multipoint connector
Interface IF2	
Fieldbus	ETHERNET Powerlink
Type	100 Base-T (ANSI/IEEE 802.3)
Design	Shielded RJ45 port
Transfer rate	100 MBit/s
Cable length	Max. 100 m between two stations (segment length)
General information	3IF789.9
Status indicators	Send/receive data for IF1 Status of the Powerlink station, network activity, link/collision for IF2
Diagnostics	
Data transfer (IF1)	Yes, with status LED and software status
Station status (IF2)	Yes, with status LED and software status
Bus function (IF2)	Yes, with status LED and software status
Electrical isolation	
PLC - IFx	Yes
IF1 - IF2	Yes
Power consumption	
3.3 V	2.3 W
5 V	0.5 W
Total	2.8 W
Certification	CE, C-UL-US, GOST-R
Mechanical characteristics	3IF789.9
Slot	Insert e.g. in CP360
Protection type	IP20
Operating / Storage temperature	0°C to +60°C / -25°C to +70°C
Relative humidity	5 to 95%, non-condensing
Comment	1 x TB704 terminal block separately

Required accessories	
0TB704.9	Accessory, terminal block, 4-pin, screw clamps, 1.5 mm ²
0TB704.91	Accessory, terminal block, 4-pin, cage clamps, 2.5 mm ²

aPCI interface module IF791



- X2X Link connection

Short description	3IF791.9
Communication module	1 x X2X Link master
Interfaces	3IF791.9
Interface IF1	
Type	X2X Link master
Design	4-pin multipoint connector
General information	3IF791.9
Status indicators	Data transmission and status of IF1
Diagnostics	
Data transfer	Yes, with status LED
Electrical isolation	
PLC - IF1	Yes
Power consumption	
3.3 V	0.43 W
5 V	0.76 W
Total	1.19 W
Certification	CE, GOST-R
Mechanical characteristics	3IF791.9
Slot	Insert e.g. in CP360
Protection type	IP20
Operating / Storage temperature	0°C to +60°C / -25°C to +70°C
Relative humidity	5 to 95%, non-condensing
Comment	1 x TB704 terminal block separately

Required accessories	
0TB704.9	Accessory, terminal block, 4-pin, screw clamps, 1.5 mm ²
0TB704.91	Accessory, terminal block, 4-pin, cage clamps, 2.5 mm ²

aPCI interface module IF792



- Dual X2X Link connection
- RS232 can be configured as an online interface

Short description	3IF792.9
Communication module	1 x RS232, 2 x X2X Link master
Interfaces	3IF792.9
Interface IF1	
Type	RS232
Design	9-pin DSUB plug
Maximum transfer rate	115.2 kBit/s
IF2/IF3 Interface	
Type	X2X Link master
Design	4-pin multipoint connector
General information	3IF792.9
Status indicators	2 LEDs for sending/receiving data for IF1 1 LED each for sending/receiving data for IF2 and IF3
Diagnostics	
Data transfer	Yes, with status LEDs
Electrical isolation	
PLC - IF1	No
PLC - IF2/IF3	Yes
IFx - IFx	Yes
Power consumption	
3.3 V	0.5 W
5 V	1.35 W
Total	1.85 W
Certification	CE, C-UL-US, GOST-R
Mechanical characteristics	3IF792.9
Slot	Insert e.g. in CP360
Protection type	IP20
Operating / Storage temperature	0°C to +60°C / -25°C to +70°C
Relative humidity	5 to 95%, non-condensing
Comment	0TB704.9 terminal block separately

Required accessories	
0TB704.9	Accessory, terminal block, 4-pin, screw clamps, 1.5 mm ²
Optional accessories	
OG0001.00-090	Cable PC <-> PLC/PW, RS232, online cable

aPCI interface module IF797



- X2X connection
- CAN bus interface
- RS232 can be configured as an online interface

CAN

Short description	3IF797.9-1
Communication module	1 x RS232, 1 x CAN bus, 1 x X2X Link master
Interfaces	3IF797.9-1
Interface IF1	
Type	RS232
Design	9-pin DSUB plug
Maximum transfer rate	115.2 kBit/s
Interface IF2	
Type	CAN bus
Design	4-pin multipoint connector
Maximum transfer rate	500 kBit/s
Interface IF3	
Type	X2X Link master
Design	4-pin multipoint connector
General information	3IF797.9-1
Status indicators	2 LEDs for sending/receiving data for IF1 1 LED each for sending/receiving data for IF2 and IF3
Diagnostics	
Data transfer	Yes, with status LEDs
Electrical isolation	
PLC - IF1	No
PLC - IF2/IF3	Yes
IFx - IFx	Yes
Power consumption	
3.3 V	0.68 W
5 V	1.28 W
Total	1.96 W
Certification	CE, C-UL-US, GOST-R
Mechanical characteristics	3IF797.9-1
Slot	Insert e.g. in CP360
Protection type	IP20
Operating / Storage temperature	0°C to +60°C / -25°C to +70°C
Relative humidity	5 to 95%, non-condensing
Comment	0TB704.9 terminal block separately Replaces interface module 3IF797.9 starting with AS 2.4

Required accessories	
0TB704.9	Accessory, terminal block, 4-pin, screw clamps, 1.5 mm ²
Optional accessories	
0G0001.00-090	Cable PC <-> PLC/PW, RS232, online cable
0AC913.93	Bus adapter, CAN, 2 CAN interfaces, including 30 cm connection cable (TB704)

Positioning module NC161



The NC161 is an encoder module with symmetrical incremental or absolute encoder evaluation. It is used for single axis positioning with ramps in conjunction with the AO352 analog output module.

The 5 V encoder supply is available directly on the module. The 24 V encoder supply voltage must be connected externally.

The following special functions are available:

- Latching the counter status using the reference enable switch
- Use of a comparator output during incremental encoder operation

Short description	7NC161.7
I/O module	1 x incremental or SSI absolute encoder
Incremental encoder inputs	7NC161.7
Number	1
Counter size	32-bit
Input frequency	100 kHz
Evaluation	4-fold
Signal form	Square wave pulse
Design	15-pin DSUB socket
SSI absolute encoder	7NC161.7
Number	1
Counter size	31-bit
Maximum transfer rate	100 kBit/s
Design	15-pin DSUB socket
Digital inputs	7NC161.7
Number of channels	2
Rated voltage	24 VDC
Connection	
Reference enable switch	Using terminal block
Reference pulse	Using 15-pin DSUB socket
Electrical isolation	
Input - PLC	Yes
Encoder supply	7NC161.7
Output voltage	+5 VDC / max. 500 mA without external feed, short circuit and overload protection
External supply voltage	+24 VDC / max. 300 mA, short circuit protection
General information	7NC161.7
Power consumption	0.3 W + I _{encoder} x 5.4 V
Certification	CE, C-UL-US, GOST-R
Mechanical characteristics	7NC161.7
Slot	Adapter module, CPU with local slots for B&R 2003 screw-in modules
Protection type	IP20
Operating temperature	
Horizontal installation	0°C to +60°C
Vertical installation	0°C to +50°C
Storage temperature	-25°C to +70°C
Relative humidity	5 to 95%, non-condensing

Accessories



Module racks with two side sections (7BP7xx.0)

	7BP702.0	7BP703.0	7BP704.0	7BP705.0	7BP706.0	7BP707.0	7BP708.0	7BP709.0	7BP710.0
Number of module slots	2	3	4	5	6	7	8	9	10
Material	Aluminum								
Fastening the modules	Hang modules in the rack and screw into place (threaded strips in frame)								
Mounting the module rack	Integrated mounting mechanics (standard mounting rail)								
Certification	CE, C-UL-US, GOST-R								
Dimensions [mm]									
Height	115	115	115	115	115	115	115	115	115
Width ¹⁾	161.5	238	314.5	391	467.5	544	620.5	697	773.5
Depth	23	23	23	23	23	23	23	23	23

1) Includes 8.5 mm for two side sections and mounting screws

Module racks with one side section (7BP70x.1)

These module racks are, for example, used together with the EX270 CAN bus controller.

	7BP701.1	7BP702.1
Number of module slots	1	2
Material	Aluminum	
Fastening the modules	Hang modules in the rack and screw into place (threaded strips in frame)	
Mounting the module rack	Integrated mounting mechanics (standard mounting rail)	
Certification	CE, C-UL-US, GOST-R	
Dimensions [mm]		
Height	115	115
Width ¹⁾	81	157.5
Depth	23	23

1) Includes 4.5 mm for one side section and mounting screws

Optional accessories

7AC020.9	2003 bus cover, 1 pc.	108
7AC010.9	2003 bus cover, 5 pcs.	108



Application memory module ME770

The application memory module is for nonvolatile storage of operating parameters and initialization of a CAN node. Data is taken from configuration memory if the node number set on the module corresponds to the one stored or if the node number on the module is set to 0.

Short description	7ME770.5
Application memory	For storing the operating parameters of a CAN node
Program memory	7ME770.5
Memory type	4 KBit S-EEPROM
Programming	canio CAN library if the the ME770 is inserted on the CAN bus controller
Design	9-pin DSUB plug
General information	7ME770.5
Power consumption	0.1 W
Certification	CE, C-UL-US, GOST-R



Bus cover AC010 / AC020

If a module slot remains free, fitting a bus cover on the first free slot is recommended. In this way, the last module can be protected from damage.

	7AC010.9	7AC020.9
Number of bus covers	5	1



Stress relief attachment AC011

The stress relief attachment is intended to be used for wiring the DO721 or DO722 digital output module. It prevents the cabling from placing too much stress on the 4-pin connectors.

The stress relief attachment is mounted underneath the DO721 or DO722. The wires running into the module are then secured to the stress relief attachment using cable ties. In this way, the connectors are freed from stress and the integrity of the electrical wiring can be guaranteed.

	7AC011.9
Short description	2003 stress relief attachment, 5 pcs., incl. mounting material

Accessories



aPCI slot cover

If the slot for an optional interface module in the CP570 or CP476-020 is free, an aPCI slot cover is recommended. In this way, the slot is protected from dirt and damage.

7AC570.1

Short description

2003 accessories - aPCI slot cover

Terminal blocks

22-pin terminal block TB722

The TB722 terminal block is used to supply the digital inputs on the DM435 module. It is a 22-pin dual-level terminal block with either screw clamps or cage clamps. All connections in a terminal row are electrically connected.



Short description	7TB722.9	7TB722.91
Type of terminal	Screw clamps	Cage clamps
Distance between contacts	5.08 mm	5.08 mm
Contact resistance	$\leq 1 \text{ m}\Omega$	-
Rated voltage	300 V	300 V
Rated current ¹⁾	10 A / contact	10 A / contact
Connection cross section		
AWG wire	26 - 12 AWG	24 - 14 AWG
Solid wire line	0.50 - 6.00 mm ²	0.50 - 2.50 mm ²
Fine wire line without wire tip sleeves	0.50 - 4.00 mm ²	0.50 - 1.50 mm ²
Fine wire line with wire tip sleeves	0.50 - 2.50 mm ²	0.25 - 1.50 mm ²
Wire tip sleeves with plastic covering	0.50 - 2.50 mm ²	0.25 - 1.50 mm ²
Cable type	Copper wires only (no aluminum wires!)	Copper wires only (no aluminum wires!)
Dimensions (W x H x D)	76 x 33 x 52 mm	76 x 33 x 33 mm
Comment	All terminals in a terminal row connected electrically, nominal values according to UL	

33-pin terminal block TB733

The TB733 terminal block is used as an additional jumper terminal if the digital mixed module DM435 is operated using a 3-line connection. The TB733 is a 33-pin 3-level terminal block with either screw clamps or cage clamps. All terminals in a terminal row are electrically connected.

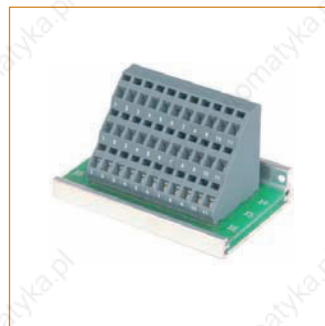

Short description	7TB733.9	7TB733.91
Type of terminal	Screw clamps	Cage clamps
Distance between contacts	5.08 mm	5.08 mm
Contact resistance	$\leq 1 \text{ m}\Omega$	-
Rated voltage	300 V	300 V
Rated current ¹⁾	10 A / contact	10 A / contact
Connection cross section		
AWG wire	26 - 12 AWG	24 - 14 AWG
Solid wire line	0.50 - 6.00 mm ²	0.50 - 2.50 mm ²
Fine wire line without wire tip sleeves	0.50 - 4.00 mm ²	0.50 - 1.50 mm ²
Fine wire line with wire tip sleeves	0.50 - 2.50 mm ²	0.25 - 1.50 mm ²
Wire tip sleeves with plastic covering	0.50 - 2.50 mm ²	0.25 - 1.50 mm ²
Cable type	Copper wires only (no aluminum wires!)	Copper wires only (no aluminum wires!)
Dimensions (W x H x D)	76 x 48 x 52 mm	76 x 48 x 44 mm
Comment	All terminals in a terminal row connected electrically, nominal values according to UL	

¹⁾ The respective limit data for the I/O modules must be taken into consideration.

36-pin terminal block TB736

The TB736 terminal block is used to supply the digital inputs on the DM465 module. The TB736 consists of two 18-pin connectors and corresponding socket connectors as screw or cage clamp terminal blocks with ejection levers. All terminals in a terminal row are electrically connected.

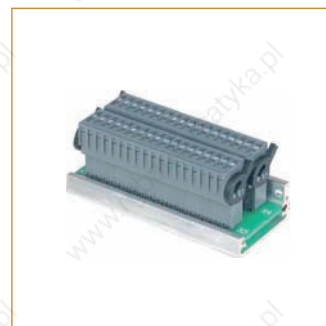

Short description	7TB736.9	7TB736.91
Type of terminal	Screw clamps	Cage clamps
Distance between contacts	3.5 mm	3.5 mm
Contact resistance	≤4.2 mΩ	≤4.2 mΩ
Rated voltage	300 V	300 V
Rated current ¹⁾	10 A / contact	10 A / contact
Connection cross section		
AWG wire	28 - 14 AWG	26 - 14 AWG
Solid wire line	0.20 - 1.50 mm ²	0.20 - 1.50 mm ²
Fine wire line without wire tip sleeves	0.20 - 1.50 mm ²	0.20 - 1.50 mm ²
Fine wire line with wire tip sleeves	0.20 - 1.50 mm ²	0.20 - 1.50 mm ²
Wire tip sleeves with plastic covering	0.20 - 1.50 mm ²	0.20 - 1.00 mm ²
Cable type	Copper wires only (no aluminum wires!)	Copper wires only (no aluminum wires!)
Dimensions (W x H x D)	76 x 33 x 32 mm	76 x 33 x 32 mm
Comment	All terminals in a terminal row connected electrically, mechanical removal help, nominal values according to UL	

54-pin terminal block TB754

The terminal block is used as an additional jumper terminal and is specially designed for 3-line connections, e.g. for the DM465 (3-line sensors). The TB754 consists of three 18-pin connectors and corresponding socket connectors as screw or cage clamp terminal blocks with ejection levers. All terminals in a terminal row are electrically connected.



Short description	7TB754.9	7TB754.91
Type of terminal	Screw clamps	Cage clamps
Distance between contacts	3.5 mm	3.5 mm
Contact resistance	≤4.2 mΩ	≤4.2 mΩ
Rated voltage	300 V	300 V
Rated current ¹⁾	10 A / contact	10 A / contact
Connection cross section		
AWG wire	28 - 14 AWG	26 - 14 AWG
Solid wire line	0.20 - 1.50 mm ²	0.20 - 1.50 mm ²
Fine wire line without wire tip sleeves	0.20 - 1.50 mm ²	0.20 - 1.50 mm ²
Fine wire line with wire tip sleeves	0.20 - 1.50 mm ²	0.20 - 1.50 mm ²
Wire tip sleeves with plastic covering	0.20 - 1.50 mm ²	0.20 - 1.00 mm ²
Cable type	Copper wires only (no aluminum wires!)	Copper wires only (no aluminum wires!)
Dimensions (W x H x D)	76 x 50 x 32 mm	76 x 50 x 32 mm
Comment	All terminals in a terminal row connected electrically, mechanical removal help, nominal values according to UL	

1) The respective limit data for the I/O modules must be taken into consideration.

Terminal blocks

72-pin terminal block TB772

The TB772 terminal block is used as an additional jumper terminal if the digital mixed module DM465 is operated using a 3-line connection. The TB772 consists of two 36-pin connectors and corresponding socket connectors as cage clamp terminal blocks. All terminals in a terminal row are electrically connected.



Short description	7TB772.91
Type of terminal	2-row cage clamp terminal block
Distance between contacts	3.5 mm
Contact resistance	$\leq 7 \text{ m}\Omega$
Rated voltage	50 V
Rated current ¹⁾	5 A / contact
Connection cross section	
AWG wire	TBD AWG
Solid wire line	0.20 - 1.00 mm ²
Fine wire line without wire tip sleeves	0.20 - 1.00 mm ²
Fine wire line with wire tip sleeves	-
Wire tip sleeves with plastic covering	-
Cable type	Copper wires only (no aluminum wires!)
Dimensions (W x H x D)	76 x 48 x 34 mm
Comment	All terminals in a terminal row connected electrically, nominal values according to UL

1) The respective limit data for the I/O modules must be taken into consideration.



Mechanical and electrical configuration

Dimensions

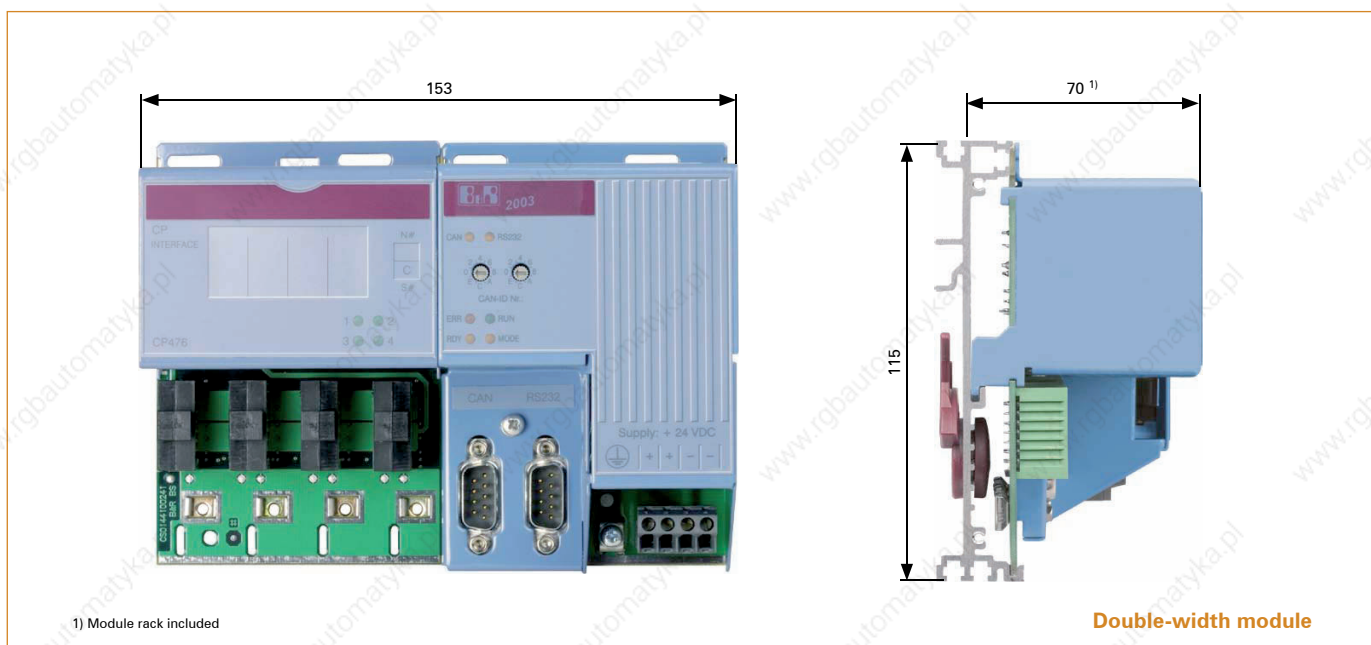
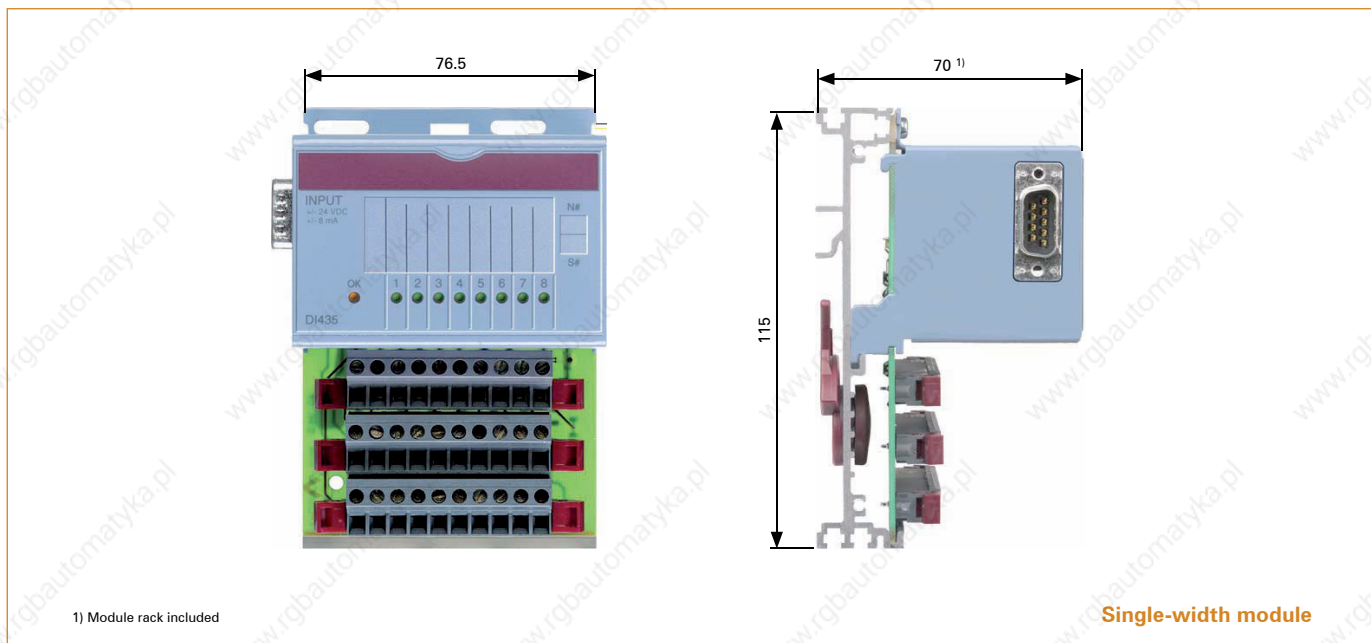

Dimensions

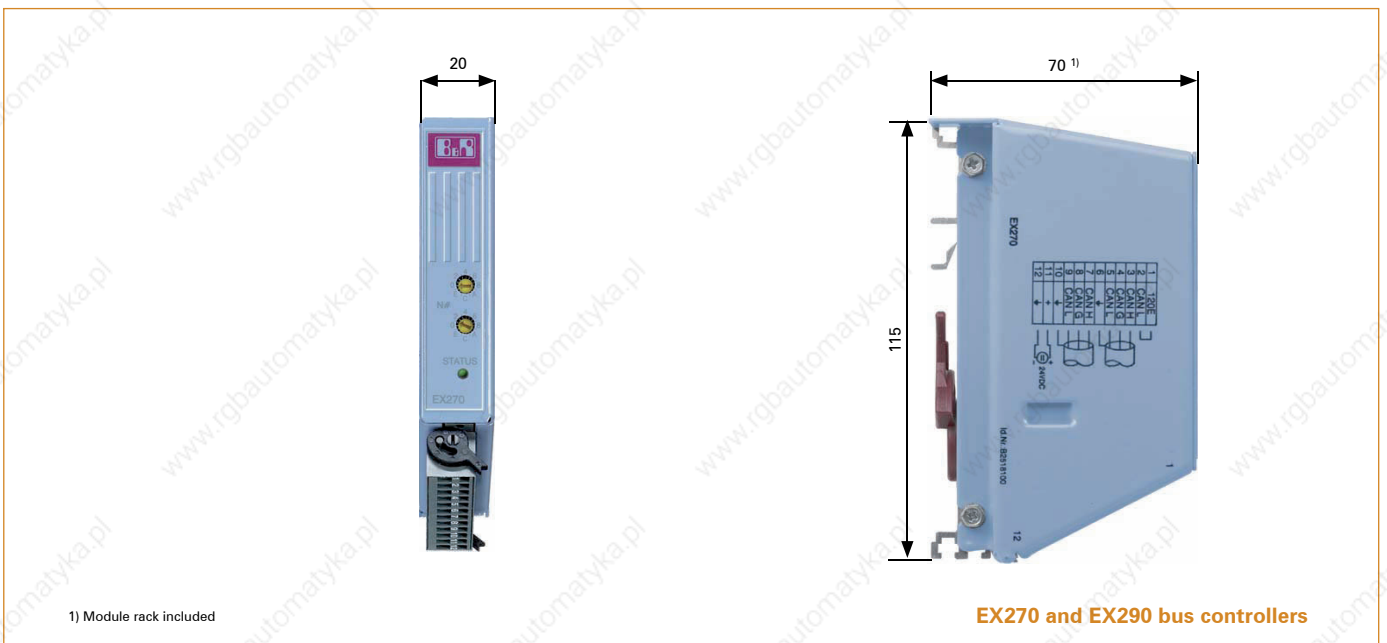
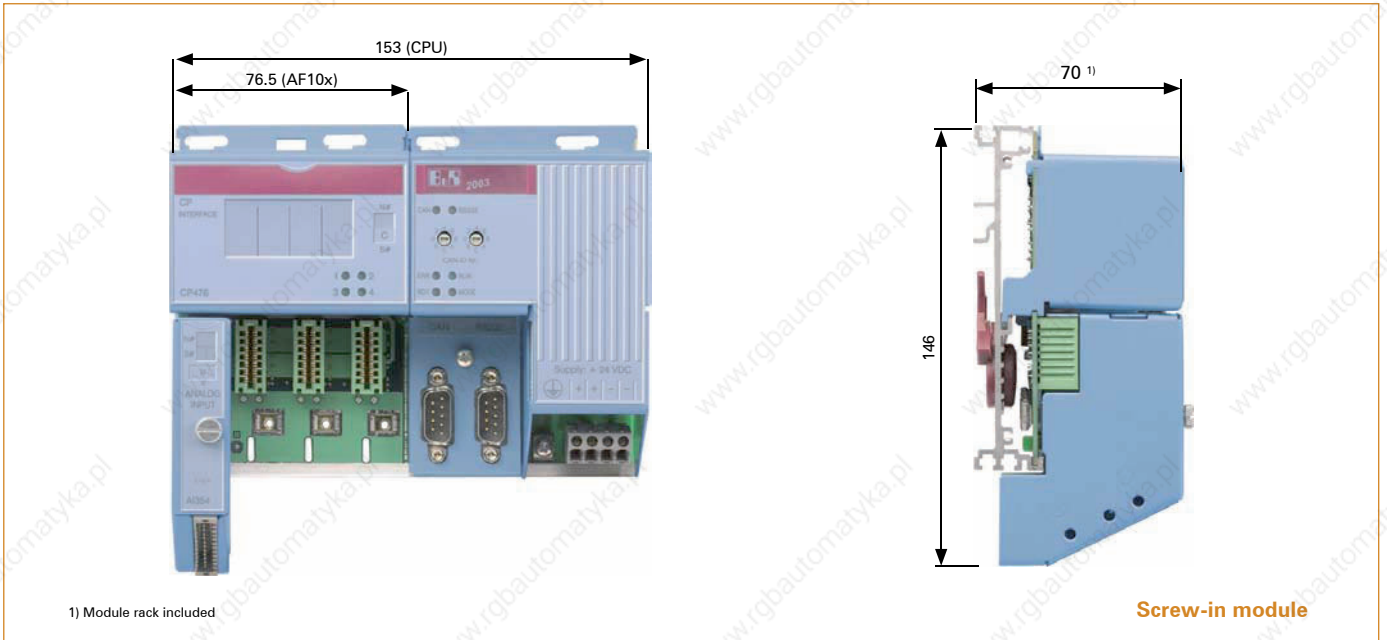

Mechanical and electrical configuration

Dimensions

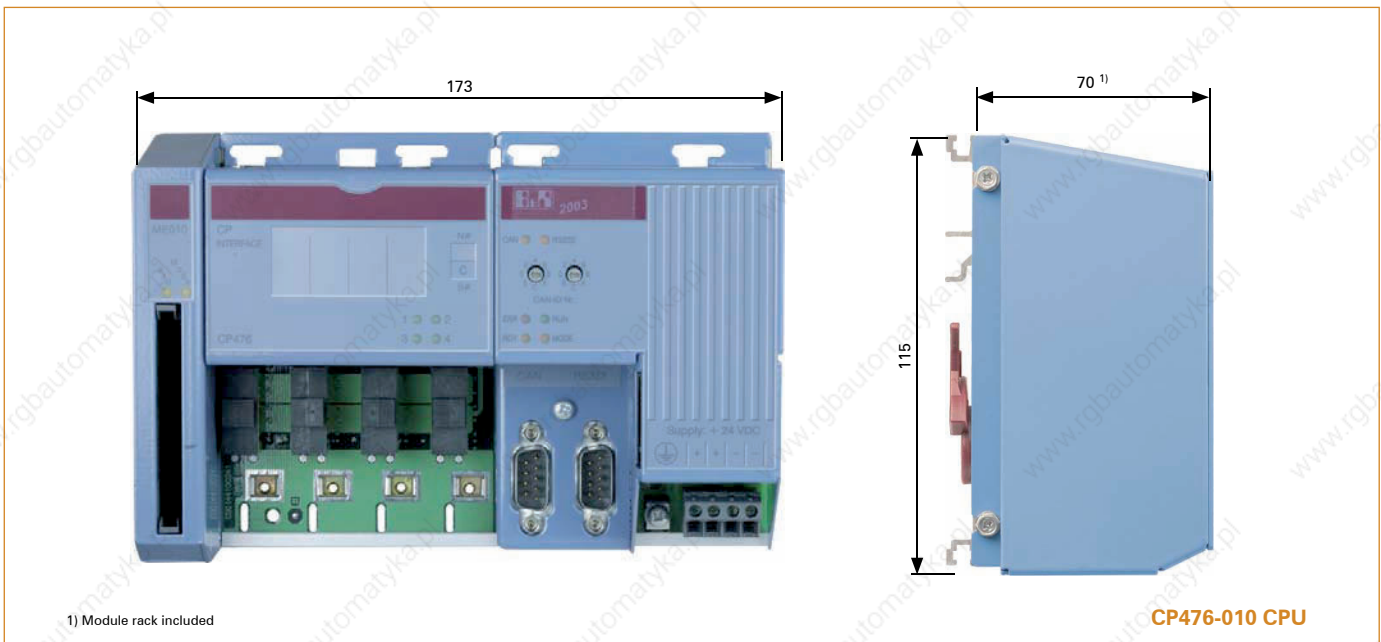
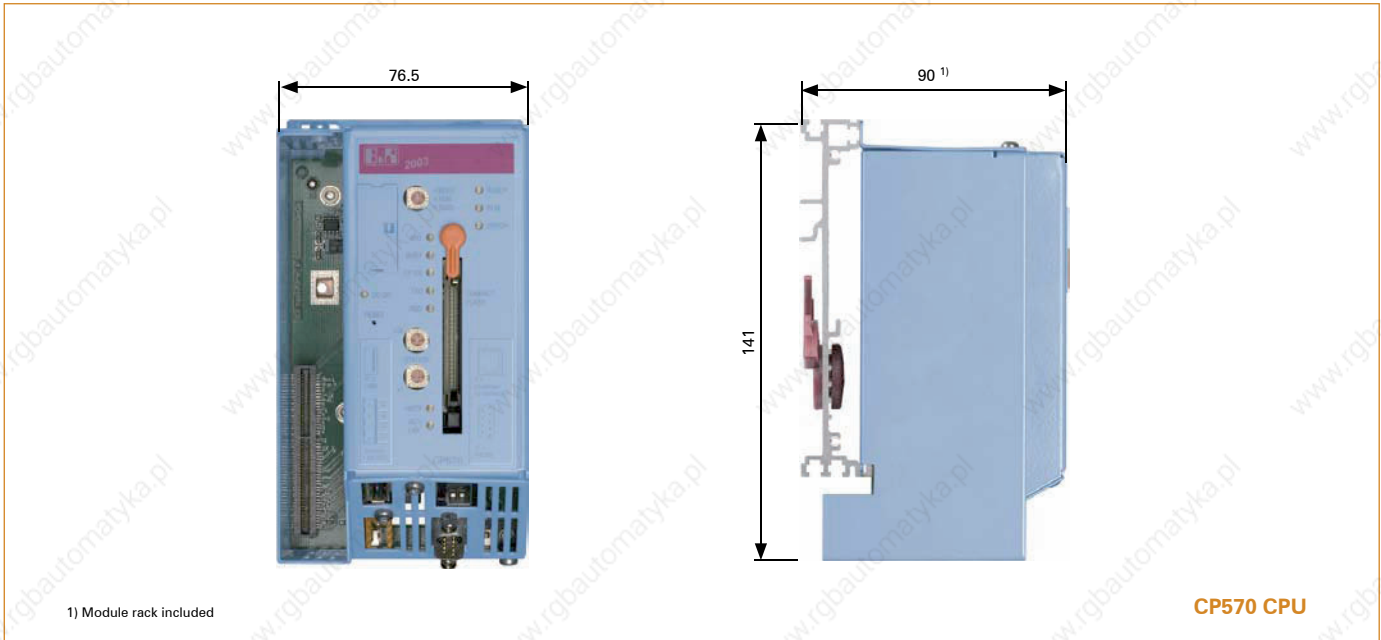

Dimensions

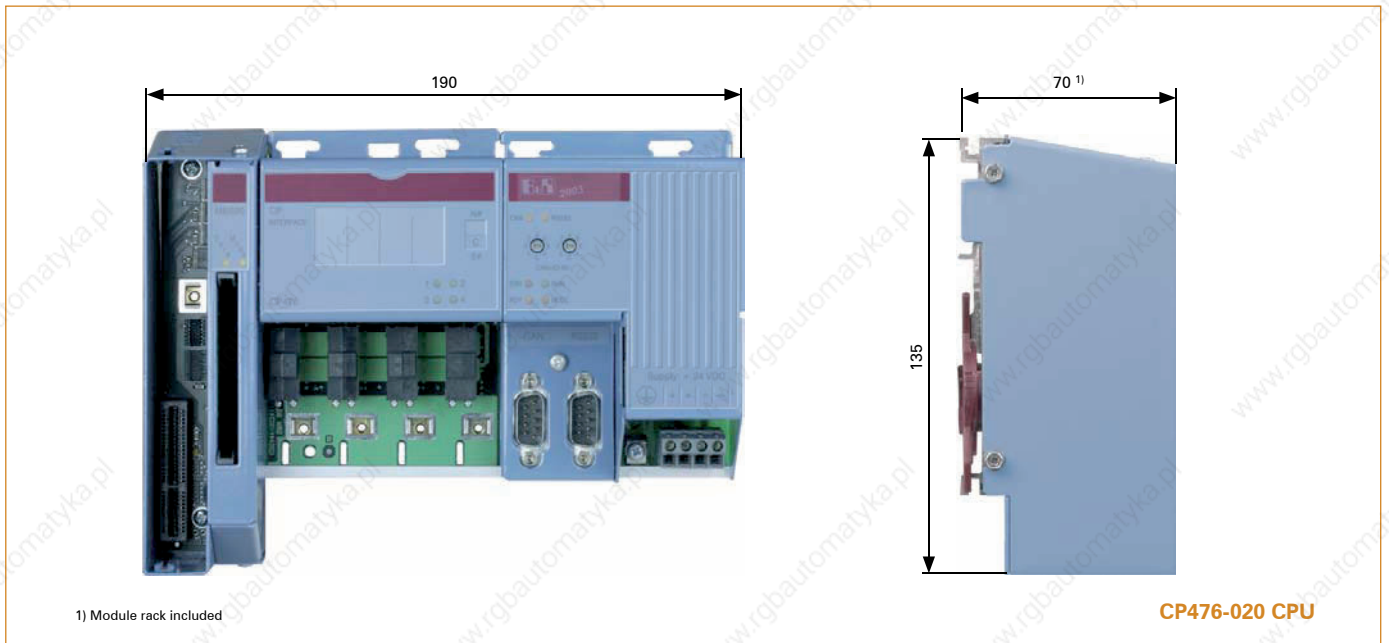

Mechanical and electrical configuration

Horizontal installation dimensions

Note the following dimensions for horizontal installation in a switching cabinet or housing.

Dimensions for horizontal installation

Width	See section "Module rack" 107
Height	
Without screw-in modules	h = 115 mm
With screw-in modules	h = 146 mm

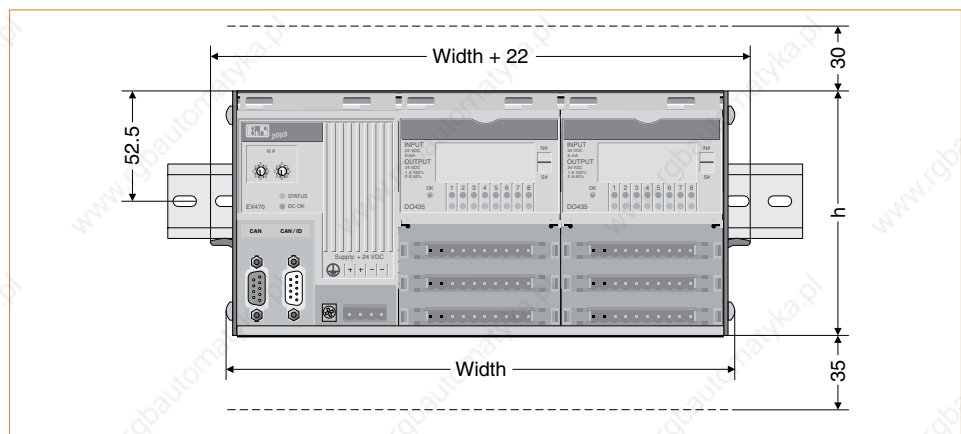

There must be at least 30 mm free space above the modules. The cooling vents are not allowed to be covered. Underneath the System 2003, 35 mm space must be left free for the input, output and supply cables.

Standard installation

If the controller is installed in the module rack, 22 mm must be added to the width listed in the section "Module racks with two side sections (7BP7xx.0)" on page 107.

Installation with EX270 and EX290 bus controllers

These CAN bus controllers are used together with the module racks with model number 7BP70x.1. The bus controller is screwed onto the module rack instead of the left side section. 31 mm must be added to the width listed in section "Module racks with one side section (7BP70x.1)" (107).

Vertical installation dimensions

Note the following dimensions for vertical installation in a switching cabinet or housing.

Dimensions for vertical installation

Height	See section "Module rack" § 107
Width	
Without screw-in modules	w = 115 mm
With screw-in modules	w = 146 mm

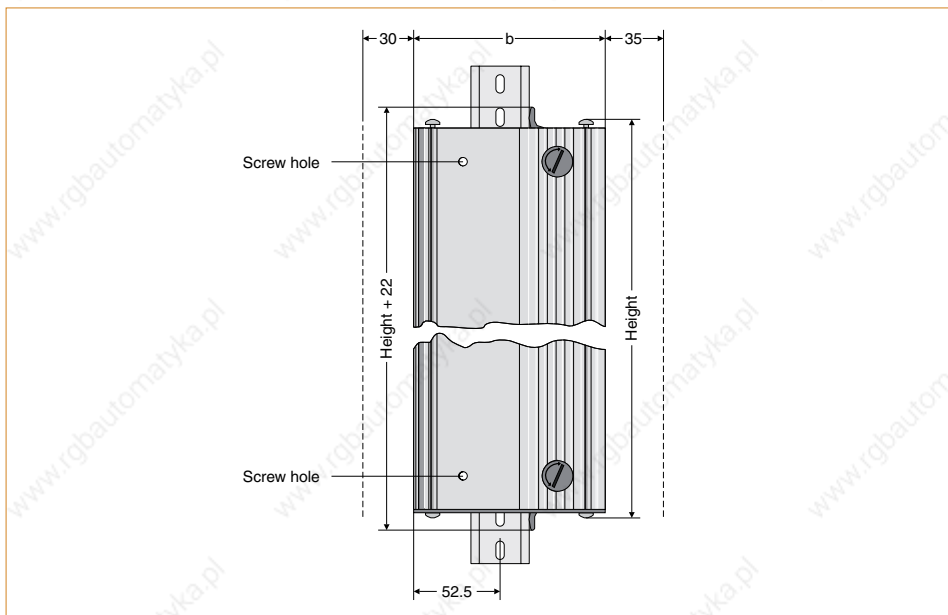

At least 30 mm space must be left free on the left side of the module. The cooling vents are not allowed to be covered. On the right side of the System 2003, 35 mm space must be left free for the input, output and supply cables.

The CPU is held in place by two screws to stop it slipping. Before the module rack can be screwed in place, the threaded strips must be pushed in and the left side section and screws for the right side section must be pre-mounted.

The modules must be arranged so that the controller is on the lower end of the module rack. The temperature range is limited to 0 - 50 °C when installing modules vertically.

Mechanical and electrical configuration

Standard installation

In order to calculate the height if the controller is installed in the module rack, 22 mm must be added to the width listed in the section "Module racks with two side sections (7BP7xx.0)" on page 107.

Installation with EX270 and EX290 bus controllers

These CAN bus controllers are used together with the module racks with model number 7BP70x.1. The bus controller is screwed onto the module rack instead of the left side section.

For calculating the height, 31 mm must be added to the width listed in section "Module racks with one side section (7BP70x.1)" (107).

Installation

A mounting rail conforming to the EN 60715 standard (TH35-7.5) is required to mount the PLC. The mounting rail is fastened to the back wall of the switching cabinet.

The module rack is then mounted at the desired position on the mounting rail and secured using the fastening lever.

Controller, CPU and I/O modules are hung in the module rack and screwed to a threaded strip which is inserted in the aluminum frame. The electrical connection between the modules is made using a 9-pin DSUB plug and socket (simply push the modules together).

The risks surrounding typical ribbon cable and inserting a module into the wrong slot no longer exist.

Screw-in modules are installed on the adapter module or on the local slots of a CPU. Up to four screw-in modules can be operated on each adapter module or CPU.

Cabling terminal blocks

Cascading

The horizontal arrangement of the terminals allows the supply voltage to be cascaded. This diagram shows an example of how supply lines can be cascaded.

Check the required voltages and currents

Cascading is only possible if all modules use the same voltage. Additionally, the maximum current load on the connector is not allowed to be exceeded.

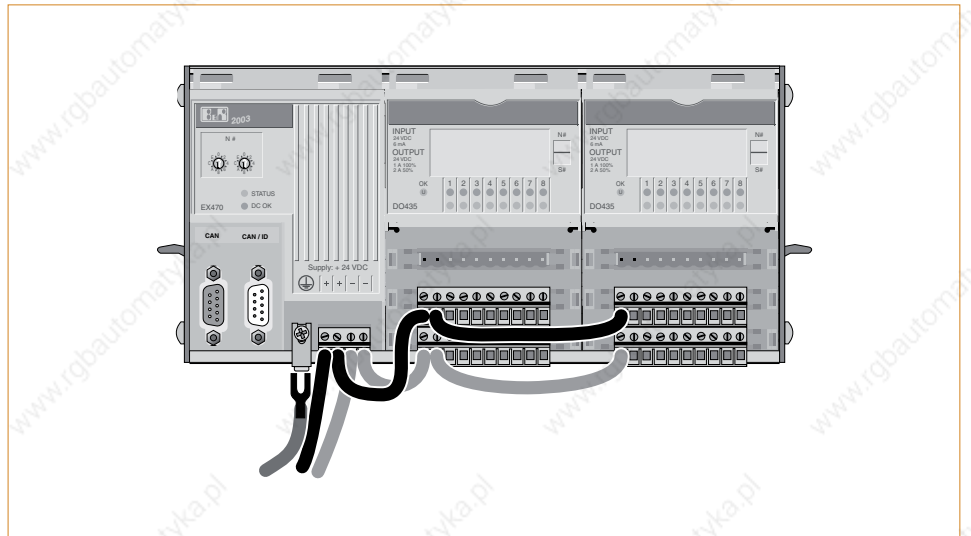

Mechanical and electrical configuration

Input and output connections

The connections for all the inputs and outputs are arranged one on top of the other. This makes it easier to locate the connections on the module. The correct lines for the respective cables are found immediately when performing maintenance. Possible exceptions to this rule are listed in the module description.

Wiring example for an I/O module:

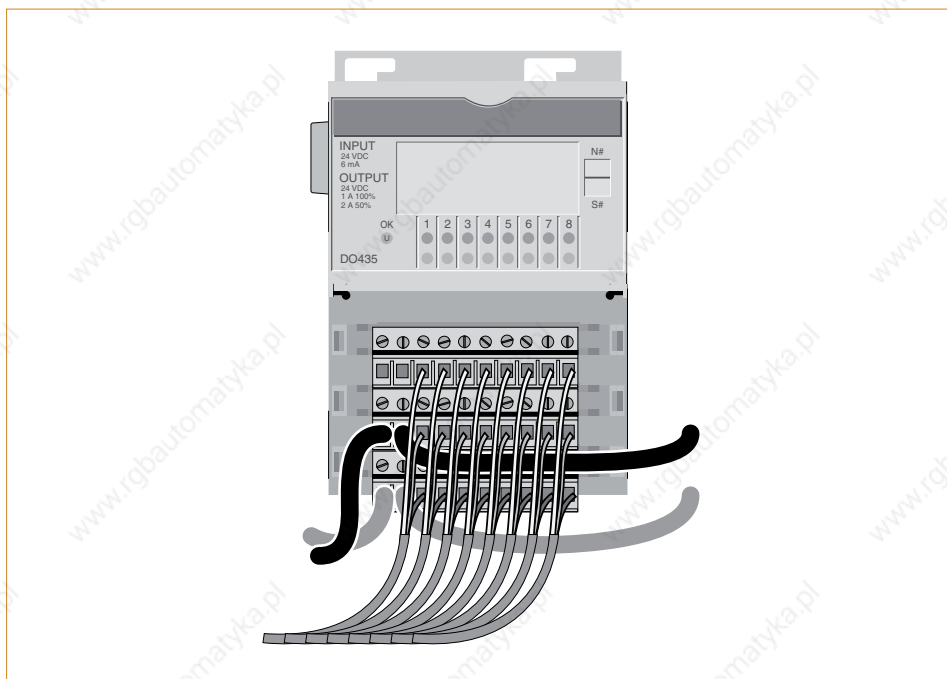

Module slot rules

Physical module slots

A physical module slot corresponds to the actual space required for a module. 2003 modules can be single-width (one module slot) or double-width (two module slots), like the CP474.

Module racks are available in different lengths for the System 2003. The palette ranges from one module slot to a max. of 10 module slots.

Logical module slots

Some modules require more than one logical module slot. That means the number of physical module slots required is different than the number of logical modules slots required (module addresses or slots in the hardware tree in B&R Automation Studio).

The maximum number of logical module slots depends on the controller. The controller also determines how many module slots are available for analog modules (see also "Modules that use logical or analog module slots", 124).

Various controllers are limited regarding the maximum number of analog module slots as well as the module addresses for analog modules. Both conditions must be met.

Controller	Maximum number of logical module slots ¹⁾	Maximum number of analog module slots ¹⁾	Possible module addresses for analog modules ²⁾
CP430	4	2	1 - 4
CP470 / CP770	8	4	1 - 8
CP474 / CP774	12	4	1 - 8
CP476	16	4	1 - 8
CP570	16	8	1 - 16
EX270	4	2	1 - 2
EX290	4	2	1 - 4
EX470 / EX770	8	4	1 - 4
EX481 / EX484	16	8	1 - 8

1) **Important:** Please take note of the power output table.

2) All analog modules and modules with logical analog sections must be operated directly next to the controller. This means they must be inserted to the left of the first digital module. Module slots 1 or 1 + 2 are used by the controllers (exception: EX270 and EX290 do not require a module slot). The first slot to the right of a controller has module address 1 and the module addresses are numbered in increasing order to the right.

Important: The module slot does not correspond to the module address; it only refers to the actual space required on the module rack. A module can also occupy several module addresses (see technical data for the module).

Mechanical and electrical configuration

Modules that use logical or analog module slots

The following table contains an overview of the modules that use two logical module slots or that use an analog module slot.

If a module uses two logical module slots and one of these slots is an analog module slot, then this one is always the first one used. The number of logical module slots corresponds to the module addresses used (slots in the hardware tree in B&R Automation Studio).

Module	Number of logical module slots	Number of analog module slots	Number of occupied physical module slots
AF101	1	1	1
AF104	1	1	1
DI439	2	-	1
DM465	2	-	1
CM211	2	1	1
CM411	2	2	1
MM432	2	1	1

Configuration examples

The following two examples display that the logical as well as the physical module assignments must be taken into consideration when configuring a System 2003.

Example 1 - Correct configuration

Configuration with one CP430 and two CM211:

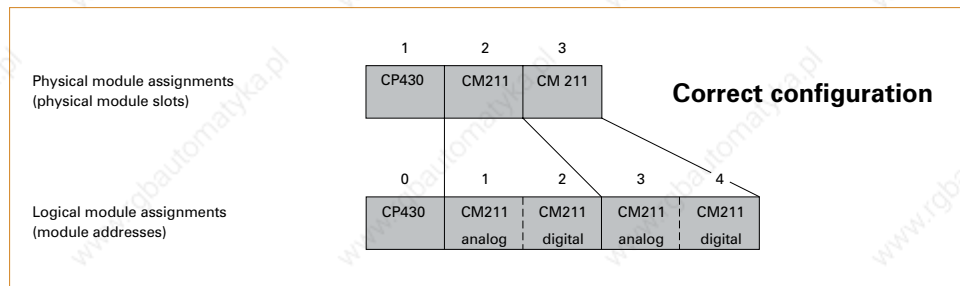

Example 2 - Incorrect configuration

Configuration with one EX270 and two CM211:

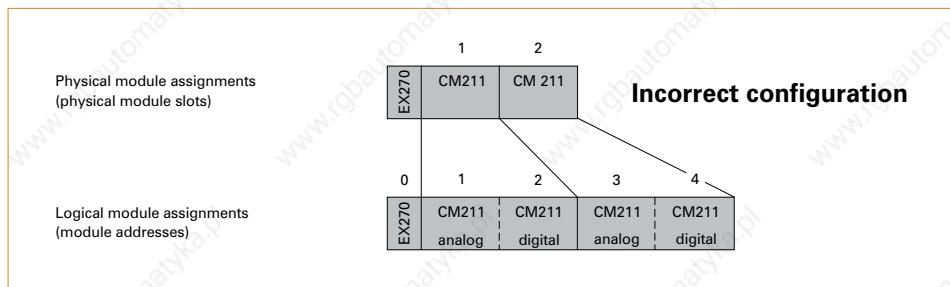

Important: Module slot 3 is not allowed to be used for analog modules on the EX270 ⇒ incorrect configuration.

Mechanical and electrical configuration

Power output table

The column labeled "Power" contains values for the power provided by a module or required by a module. This allows a power output table to be calculated quickly and easily for a particular hardware configuration.

The power provided by the bus controllers and CPUs is shown with a "+" sign. The power required by a module is shown with a "-" sign.

To calculate the power balance, the positive and negative power values should be added together. The sum may not be less than zero.

Description	Model number	Power [W]
AF101	7AF101.7	-0.3 W
AF104	7AF104.7	-0.9 W
AI261	7AI261.7	-0.6 W
AI294	7AI294.7	-0.5 W
AI351	7AI351.70	U/I: -0.3 W Pot.: -0.7 W
AI354	7AI354.70	-0.5 W
AI774	7AI774.70	-0.4 W
AM351	7AM351.70	-1.4 W
AO352	7AO352.70	-1.2 W
AT324	7AT324.70	-0.1 W
AT352	7AT352.70	-0.4 W
AT664	7AT664.70	-0.4 W
CM211	7CM211.7	-1.5 W
CM411	7CM411.70-1	-2.4 W
CP430	7CP430.60-1	+7.0 W ¹⁾
CP470	7CP470.60-2	+14.0 W ¹⁾
CP474	7CP474.60-2	+12.6 W ¹⁾
CP476	7CP476.60-1	+12.5 W ¹⁾
CP476-010	7CP476-010.9	+12.15 W ¹⁾ without PC cards
CP476-020	7CP476-020.9	+11.8 W ¹⁾ without PC cards
CP570	7CP570.60-1	+15.0 W
CP770	7CP770.60-1	+14.0 W ¹⁾
CP774	7CP774.60-1	+12.6 W ¹⁾
DI135	7DI135.70	-0.4 W
DI138	7DI138.70	-0.4 W
DI140	7DI140.70	-0.4 W
DI435	7DI435.7	-0.2 W
DI439.7	7DI439.7	-0.4 W
DI439.72	7DI439.72	-0.4 W
DI645	7DI645.7	-0.2 W
DM435	7DM435.7	-0.5 W
DM438	7DM438.72	-0.5 W
DM465	7DM465.7	-1.1 W
DO135	7DO135.70	-0.2 W
DO138	7DO138.70	-0.25 W
DO139	7DO139.70	-0.25 W
DO164	7DO164.70	-0.6 W
DO435	7DO435.7	-0.5 W
DO720	7DO720.7	-1.4 W
DO721	7DO721.7	-1.4 W
DO722	7DO722.7	-1.4 W
EX270	7EX270.50-1	+4.0 W

Description	Model number	Power [W]
EX290	7EX290.50-1	+3.0 W
EX470	7EX470.50-1	+14.5 W ²⁾
EX481	7EX481.50-1	+13.4 W
EX484	7EX484.50-1	+10.4 W
EX770	7EX770.50-1	+14.5 W ³⁾
IF311	7IF311.7	-0.5 W without Panelware panel P126 -2.3 W with Panelware panel P126
IF321	7IF321.7	-1.4 W
IF361	7IF361.70-1	-2.6 W
ME770	7ME770.5	-0.1 W
MM424	7MM424.70-1	-0.5 W
MM432	7MM432.70-1	-2.5 W
NC161	7NC161.7	-0.3 W - I _{encoder} x 5.4 V

1) Integrated power supply for simple Panelware controllers, e.g. P126

2) EX470 with revision 30.xx or higher

3) EX770 with revision 10.xx or higher

Example 1

Calculation of the System 2003 power output table using the listed hardware configuration: 8.3 W are left over from the power provided by the EX481 bus controller. The system can be operated using the desired hardware configuration.

Module	Power [W]
EX481	+13.4
AF101	-0.3
AI354	-0.5
AI354	-0.5
AO352	-1.2
AT664	-0.4
DM465	-1.1
DM465	-1.1
Residual power	8.3

Example 2

Calculation of the System 2003 power output table using the listed hardware configuration: 6.9 W are left over from the power provided by the CP474 CPU. The system can be operated using the desired hardware configuration.

Module	Power [W]
CP474	+12.6
IF321	-1.4
DI135	-0.4
DI135	-0.4
DO135	-0.2
CM211	-1.5
DI439.7	-0.4
DI439.7	-0.4
DO435	-0.5
DO435	-0.5
Residual power	6.9

Index

3

3IF613.9	83
3IF621.9	84
3IF622.9	85
3IF661.9	86
3IF671.9	87
3IF672.9	88
3IF681.86	89
3IF686.9	90
3IF722.9	91
3IF761.9	92
3IF762.9	93
3IF766.9	94
3IF771.9	95
3IF772.9	96
3IF779.9	97
3IF781.9	98
3IF782.9	99
3IF786.9	100
3IF787.9	101
3IF789.9	102
3IF791.9	103
3IF792.9	104
3IF797.9-1	105

7

7AC010.9	108
7AC011.9	108
7AC020.9	108
7AC570.1	109
7AF101.7	44
7AF104.7	45
7AI261.7	64
7AI294.7	65
7AI351.70	66
7AI354.70	67
7AI774.70	68

7AM351.70	70
7AO352.70	69
7AT324.70	71
7AT352.70	72
7AT664.70	73
7BP701.1	107
7BP702.0	107
7BP702.1	107
7BP703.0	107
7BP704.0	107
7BP705.0	107
7BP706.0	107
7BP707.0	107
7BP708.0	107
7BP709.0	107
7BP710.0	107
7CM211.7	74
7CM411.70-1	76
7CP430.60-1	36
7CP470.60-2	34
7CP474.60-2	30
7CP476.60-1	26
7CP476-010.9	24
7CP476-020.9	22
7CP570.60-1	20
7CP770.60-1	32
7CP774.60-1	28
7DI135.70	46
7DI138.70	47
7DI140.70	48
7DI435.7	49
7DI439.7	50
7DI439.72	51
7DI645.7	52
7DM435.7	61
7DM438.72	62
7DM465.7	63

7DO135.70	53
7DO138.70	54
7DO139.70	55
7DO164.70	56
7DO435.7	57
7DO720.7	58
7DO721.7	59
7DO722.7	60
7EX270.50-1	38
7EX290.50-1	39
7EX470.50-1	40
7EX481.50-1	42
7EX484.50-1	43
7EX770.50-1	41
7IF311.7	80
7IF321.7	81
7IF361.70-1	82
7ME770.5	108
7MM424.70-1	78
7MM432.70-1	79
7NC161.7	106
7TB722.9	110
7TB722.91	110
7TB733.9	110
7TB733.91	110
7TB736.9	111
7TB736.91	111
7TB754.9	111
7TB754.91	111
7TB772.91	112







www.rgbautomatyka.pl

COMPANY HEADQUARTERS

Bernecker + Rainer Industrie-Elektronik Ges.m.b.H.

B&R Strasse 1

5142 Eggelsberg

Austria

Tel.: +43 (0) 77 48/65 86 - 0

Fax: +43 (0) 77 48/65 86 - 26

info@br-automation.com

www.br-automation.com

Always close by - 120 offices in more than 50 countries - www.br-automation.com/contact

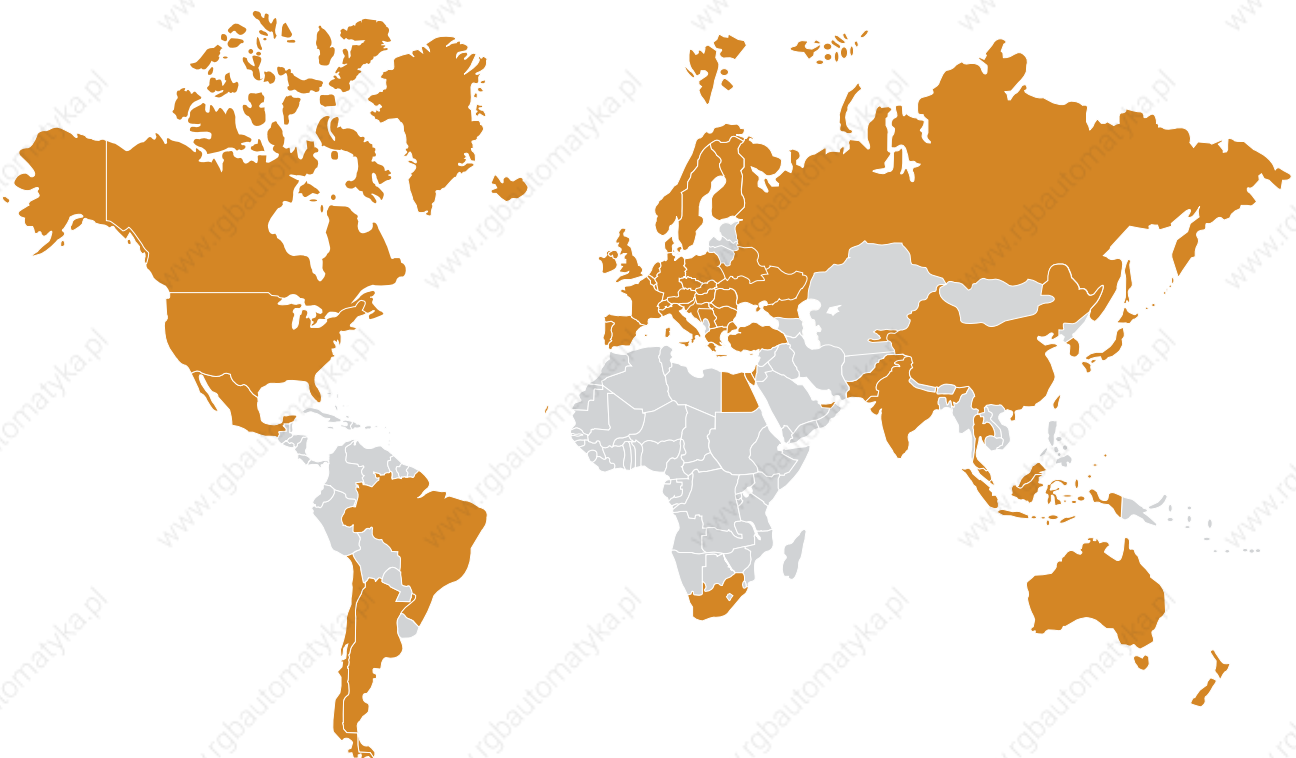

Argentina • Australia • Austria • Belarus • Belgium • Brazil • Bulgaria • Canada • Chile • China • Croatia • Cyprus • Czech Republic
Denmark • Egypt • Emirates • Finland • France • Germany • Greece • Hungary • India • Indonesia • Ireland • Israel • Italy • Japan • Korea
Kyrgyzstan • Malaysia • Mexico • The Netherlands • Norway • Pakistan • Poland • Portugal • Romania • Russia • Singapore
Slovakia • Slovenia • South Africa • Spain • Sweden • Switzerland • Taiwan • Thailand • Turkey • Ukraine • United Kingdom • USA