

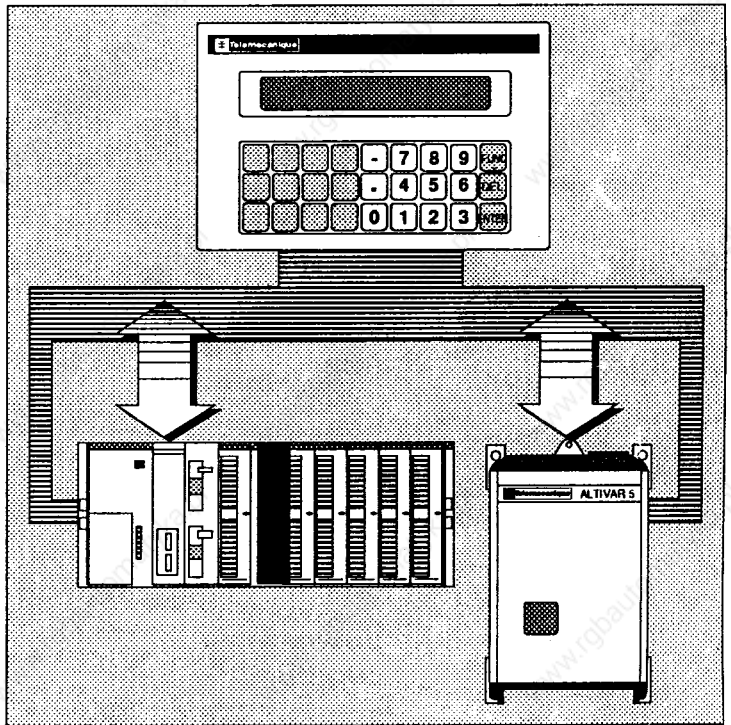

XBT-A8 Compact Terminal

UNI-TE[®] protocol

User guide 1991



www.rgbautomatyka.pl

www.rgbautomatyka.pl

www.rgbautomatyka.pl

www.rgbautomatyka.pl

www.rgbautomatyka.pl

www.rgbautomatyka.pl

www.rgbautomatyka.pl

www.rgbautomatyka.pl

www.rgbautomatyka.pl

www.rgbautomatyka.pl

www.rgbautomatyka.pl

www.rgbautomatyka.pl

www.rgbautomatyka.pl

www.rgbautomatyka.pl

www.rgbautomatyka.pl

www.rgbautomatyka.pl

www.rgbautomatyka.pl

www.rgbautomatyka.pl

www.rgbautomatyka.pl

www.rgbautomatyka.pl

www.rgbautomatyka.pl

www.rgbautomatyka.pl

www.rgbautomatyka.pl

www.rgbautomatyka.pl

NOTICE

There are three modes of operation for the XBT-A8 :

- ASCII : used by all programmable systems
- ADJUST protocol : when used with the terminal port of TSX7 PLCs.

For information about these two types of operation, refer to the XBT-XA700E user guide.

- UNI-TE protocol : used when the XBT-A8 is connected to the UNI-TELWAY bus as described in this manual.

Registered trademarks : TELWAY, UNI-TELWAY, UNI-TE, XBTEL are registered trademarks of TELEMECANIQUE.

PS/2 is a registered trademark of International Business Machines Corporation.

Contents

Section	Page
1 Introduction	
1.1 General	3
1.2 Introduction to the XBT-A8 compact terminal	4
2 Technical characteristics	
2.1 Environmental characteristics	8
2.2 Mechanical characteristics	8
2.3 Electrical characteristics	10
3 Operating modes	
3.1 General	11
3.2 Selecting modes	11
4 Configuration	
4.1 Configuration menu	12
4.2 Configuring the languages	13
4.3 Configuring the serial line for operation	14
4.4 Memory configuration	17
4.5 Syntax for storing messages	18
4.6 Storing messages using a PC-OS/2 computer	23
4.7 Checking the stored messages	24

Contents

Section	Page
5 Communication	
5.1 Introduction	25
5.2 Function modes	27
5.3 UNI-TE requests	32
5.4 General requests	37
5.5 Request to XBT-A8 resources	43
5.6 Requests to access the XBT-A8 message segment	60
5.7 Handling operator acknowledgments	64
5.8 Remote uploading and downloading of XBT-A8 memory area	65
5.9 Requests used by CLIENT XBT-A8s	81
5.10 Summary of UNI-TE requests	82
6 Application example	85
7 Connections	
7.1 Pin connections	91
7.2 Connections to PC-PS/2 computer	92
7.3 Connections to UNI-TELWAY bus	93
7.4 Test connectors	96
8 Appendices	
8.1 Automatic self-tests	97
8.2 Error messages	98
8.3 Table of ASCII codes	101

1 Introduction

1.1 General

The XBT-A8 industrial terminals are designed to provide:

- **Ergonomic operator dialogue**
 - Clear display (parameters, settings, messages, etc.)
 - Personalized function keys for control
 - Numeric keypad for entering values
 - Selection of function modes

- **Operation in an industrial environment**
 - Protected against dust and liquids
 - Readable, fluorescent green, 10 mm high alphanumeric display
 - Easy to use keypad entry with tactile response (2 mm depression)
 - Reliable isolated serial links, self-tests and removable when powered

- **An interface to control systems**
 - ASCII, ADJUSTMENT mode, UNI-TE communication protocols via an asynchronous serial line,
 - Types of serial interface : RS 232C/20 mA current loop/RS 422/485,
 - 2 types of connection :
 - . Point-to-point (RS 232C/20 mA current loop/RS 422/485),
 - . Multidrop (20 mA current loop/RS 422/485).

1 Introduction

1.2 Introduction to the XBT-A8 compact terminal

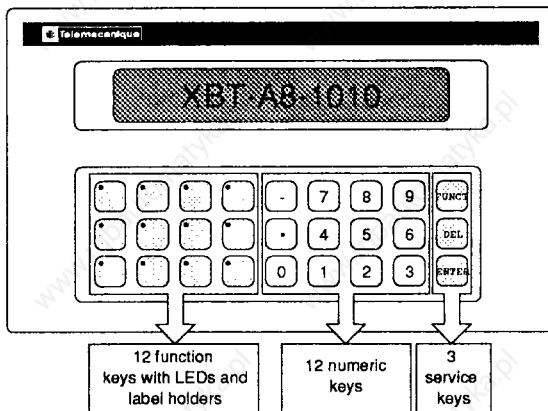

The XBT-A8 terminal consists of :

- **A single line display**

consisting of 16 green fluorescent characters, each with 14 segments plus decimal point, 10 mm high and 6.4 mm wide,

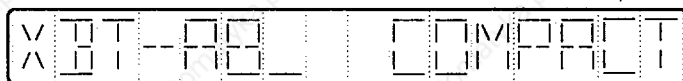

- **A keyboard**

consisting of 27 keys divided into 3 zones:

- Up to 12 function keys for user-definable operator access depending on which of the 4 models is used:

- XBT-A80101• * : 12 function keys engraved **F1** to **F12** ,

- XBT-A81101• : 12 function keys with label-holders,

- XBT-A82101• : 12 function keys with LEDs and label-holders

- XBT-A83101• : 4 red lights and 8 function keys with label-holders.

- * 0 = Latin version * 9 = Cyrillic version

- 12 numeric keys for operator responses :

- **0** to **9** and **.** for entering numbers,

- **+/-** (bistable) for entering a plus or minus sign.

- 3 service keys

- **FUNCTION** :
 - in **CONFIGURATION** mode, used to move from one menu to another,
 - in **RUNNING** mode, allows indirect access to functions.

1 Introduction

Introduction to the XBT-A8 compact terminal

- **DEL** : in CONFIGURATION mode, **accesses** the parameters in a sub-menu, in RUNNING mode, **erases** the last digit of a numerical value.
- **ENTER** : in CONFIGURATION mode, **accesses** a sub-menu in RUNNING mode, **confirms** a numeric response, **accepts** a blinking display or **stops** the buzzer.

Note : Hold down **ENTER** and then press **FUNCT** to move between CONFIGURATION mode and RUNNING mode.

• Message memory

The EEPROM type memory (non-volatile) may store up to 101 messages using 16 alphanumeric characters.

Storing the operating messages in the XBT-A8 decreases the memory requirement in the PLC and reduces data communication over the serial line.

These messages may be for example :

- operator requests

CLOSE VALVE 4

- settings

VALUE = ---

- control system requests

CHECK VALVE 12

- faults

PRESSURE FAULT

Messages to be displayed are sent to the XBT-A8 in UNI-TE protocol following a UNI-TE request.

By associating SERVER device (e.g. Altivar) addresses with TSX7 variables, the XBT-A8 can access either local or remote variables (via TELWAY).

These messages can be stored by using :

- dumb video terminals
- TSX-T407 programming terminals
- PC-PS/2 computers with XBTEL programming software. The applications (message listings) may be stored in local mode in the PC-PS/2 RAM and then transferred at any time to the XBT-A8. XBTEL can archive applications to diskette or hard disk, print applications and also perform other services such as loading and editing.

1 Introduction

Introduction to the XBT-A8 compact terminal

The system messages have been programmed in five languages (English, French, German, Spanish and Italian) to simplify all stages from design right up to operation.

Note : There is one version which supports Cyrillic characters as well as the five languages.

DESIGN	OPERATION
SYSTEM MESSAGES : Configured in the language of the designer.	MESSAGES IN THE LANGUAGE OF THE OPERATOR
APPLICATION MESSAGES : Stored in the language of the operator	

An application message consists of an operator display zone, (text which can be followed by a numeric field) together with a parameter zone used for managing the terminal.

Each message has a number.

MESSAGES		
NUMBER	TEXT	PARAMETERS
000	STOP MACHINE	
..		
012	AUTO OPERATION	
..		
084	CHECK VALVE 12	
..		
090	FAULT MOTOR 4	
..		
100	PRESSURE = _ _ _ B	W000 type N

1 Introduction

Introduction to the XBT-A8 compact terminal

• Message parameters

These define :

- The type of dialogue for the message (Type : T)
- The position of the first character in the display (Column : X)
- The access key for the message (Key : K)
- The conversion factor to be applied (Coefficient : C)
- The associated TSX7 variable in ADJUST or UNI-TE mode (Variable : V)
- Periodic reading or not of the TSX7 variable (Updating of variable : A)
- UNI-TE address of the variable (Network, Station, Gate, Module, Channel)

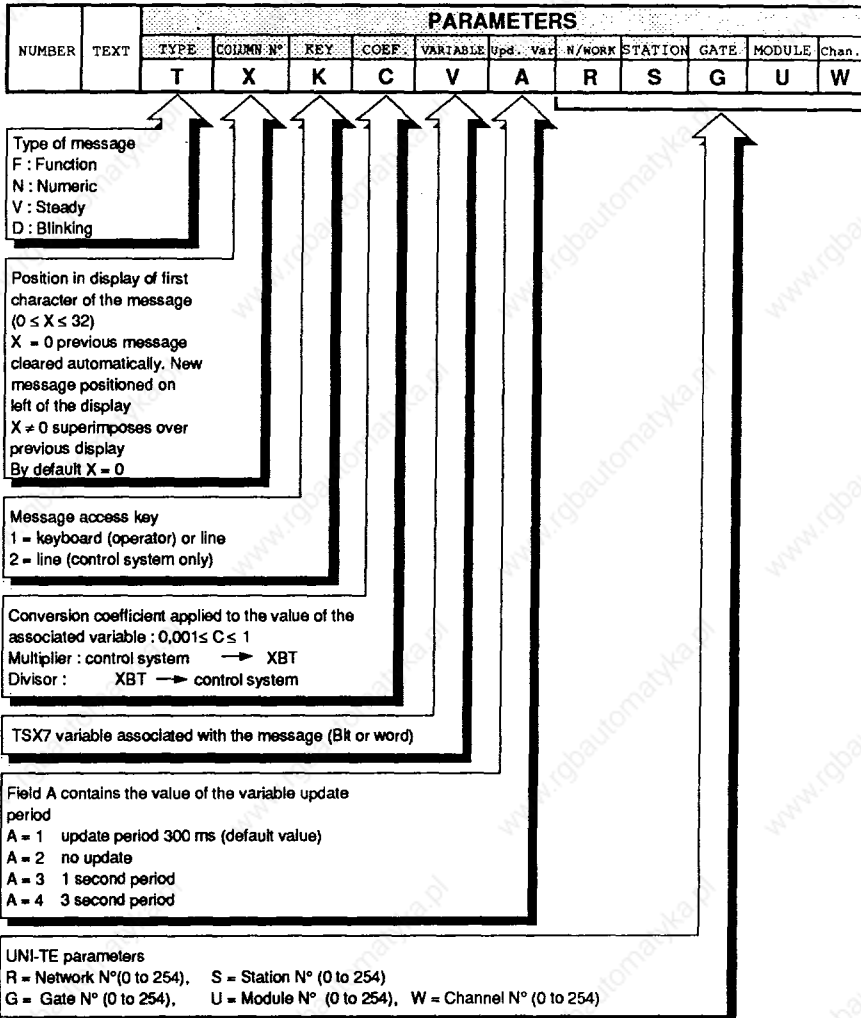

2 Technical characteristics

2.1 Environmental characteristics

Standards	IEC 801-2 to 801-4/UL 508/CSA C22-2 n°142
Degree of protection	To IEC 529/NF C 20010 : IP 653 (front face with seal)
Ambient temperature	Operation : 0° C to + 50° C Storage : - 40° C to + 70° C
Humidity	0 to 95 % without condensation
Electrical interference	Immunity to : IEC 65 / IEC 801.4 level 3
Electromagnetic interference	IEC 801.3 level 3
ESD withstand (electrostatic discharges)	To IEC 801.2 level 4
Shocks	To IEC 68-2-27 (1/2 sinusoidal pulse on 3 axes, 50g for 11ms).
Vibrations	To IEC 68-2-6 : Amplitude : ± 1 mm : 2 to 25 Hz ± 75 µm : 25 to 57 Hz Acceleration : 1g : 57 to 150 Hz.

2.2 Mechanical characteristics

Mounting	Method : flush mounting fixed by securing flange and 4 clamping screws with watertight seal. Section thickness (min. = 1.5 mm. max. = 6.0 mm). Orientation : any.
Case	Treated zinc alloy. Front face : black satin polyurethane paint.
Keyboard	27 keys (19.05 mm spacing), 2 mm depression and tactile response (2 Newtons) : - 12 function keys (with or without red LEDs) or 8 function keys and 4 red lights. - 12 numeric keys, - 3 service keys.
Connections	- Power : removable screw terminal block with 5.08 mm spacing between terminals. Clamping capacity : 1.5 mm ² . - Serial port: 25-pin female SUB D connector type HE 50 NF C 93425.
Weight	2.0 kg (4.4 lb) (without securing flange) 2.3 kg (5.1 lb) (with securing flange).

2 Technical characteristics

Mechanical characteristics

Dimensions in mm (and inches)

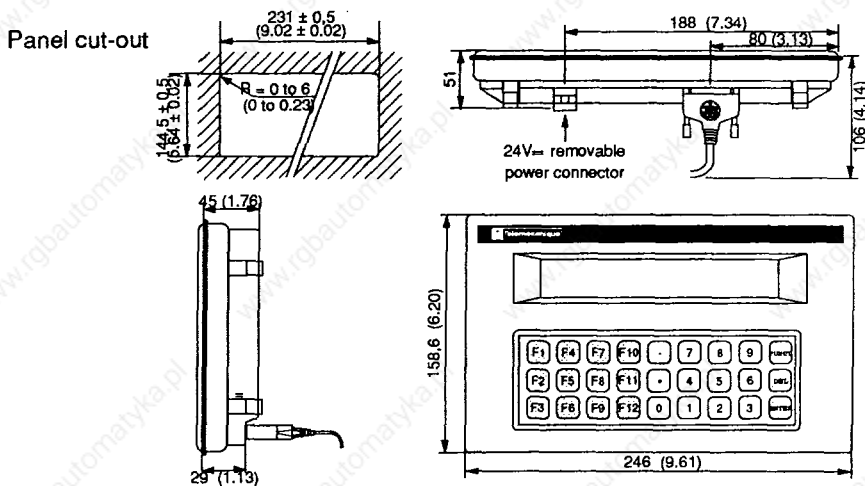

Thickness of support panel 1.5 mm to 6 mm (0.06" to 0.23")

Mounting

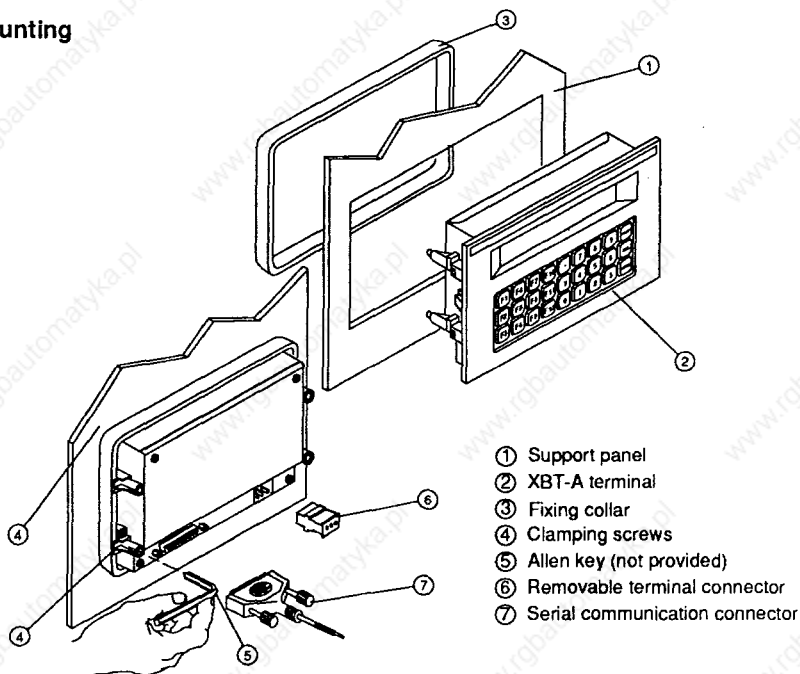

2 Technical characteristics

2.3 Electrical characteristics

• Supply	Nominal voltage	24 VDC
	Maximum ripple	25 %
	Voltage limits	18 ... 30 VDC (including ripple)
	Maximum consumption	10 W
• Display	Capacity	1 line of 16 characters
	Type	Fluorescent green, 14 segments (with decimal point)
	Size (character)	Height = 10 mm Width = 6.4 mm

• **Serial link**

The XBT-A8 is provided with an RS 422 interface

RS 422 OPTO ISOLATED ELECTRICAL CHARACTERISTICS :
CONFORM TO THE STANDARD

In UNI-TELWAY, RS 485 is used

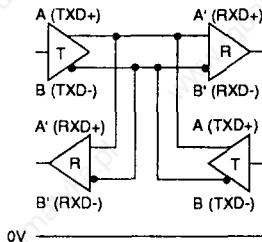

RS 485 serial link : 2-wire differential mode +
0V

**MAXIMUM TRANSMISSION SPEED OF UNI-TELWAY
NETWORK IS 19 200 BAUDS**

3 Operating modes

3.1 General

When powered-up, the XBT-A8 carries out a series of self-tests (see section 8 Appendices, SELF-TESTS) and displays the following sequence :

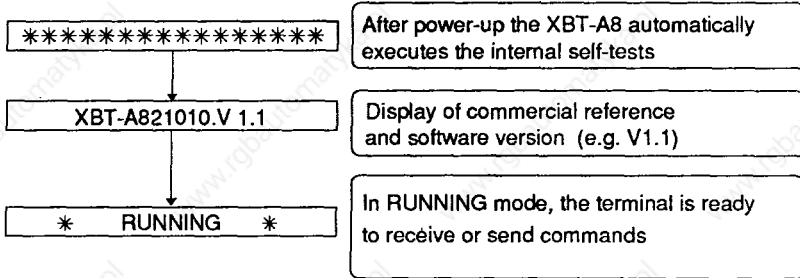

ON FIRST POWER-UP THE XBT-A8 SETS ITSELF TO ENGLISH AND AT THE END OF THE SELF-TESTS DISPLAYS

* RUNNING *

3.2 Selecting modes

Moving from one operating mode to another is achieved by holding down **(ENTER)** and then pressing **(FUNCT)** once.

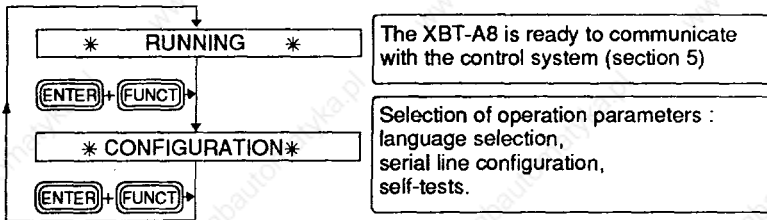

WARNING : IN CONFIGURATION MODE THE XBT-A8 TERMINAL DOES NOT COMMUNICATE WITH THE CONNECTED CONTROL SYSTEM (PLACED OFF-LINE)

ACCESS TO CONFIGURATION MODE CAN BE INHIBITED
(see section 5.5 "Access requests for XBT-A8 resources : global management of the keyboard")

4 Configuration

4.1 Configuration menu

This mode is used when setting up the XBT-A8 terminal. It allows the operator to select, using the SERVICE KEYS, the parameters required for operating the terminal.

• General menu for configuration mode

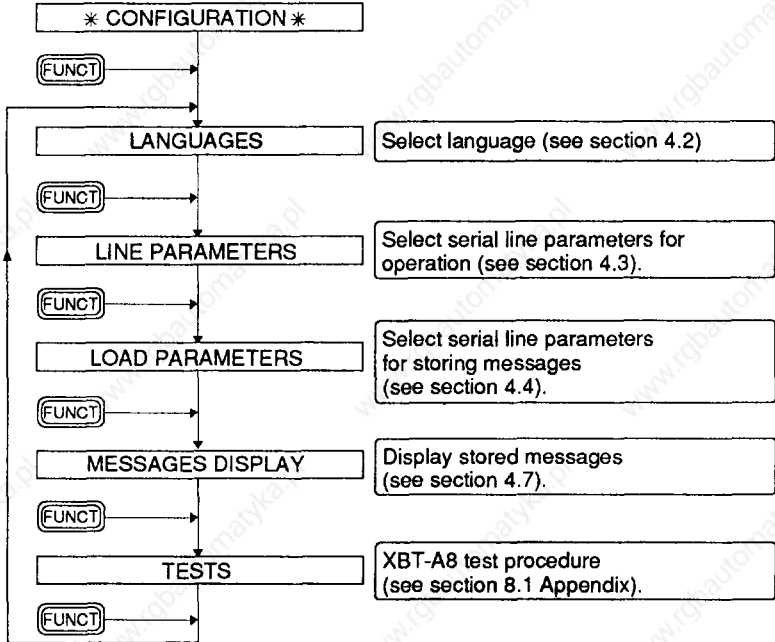

4 Configuration

4.2 Configuring the languages

WHEN FIRST POWERED-UP THE XBT-A8 TERMINAL IS SET TO ENGLISH

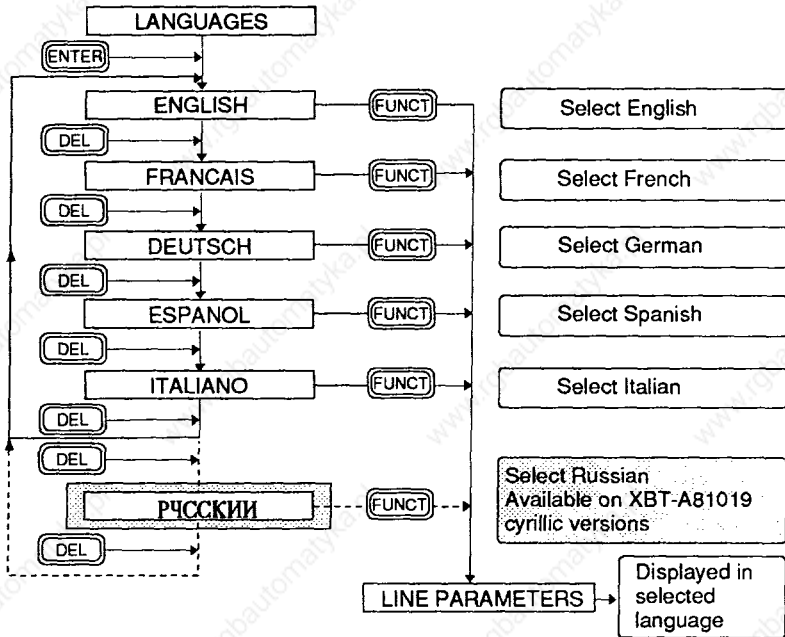

TO RETURN TO RUNNING MODE AT ANY TIME, USE

(ENTER) + (FUNCT)

THE PARAMETERS ARE SAVED
BY USING (FUNCT) OR (ENTER) + (FUNCT)

4 Configuration

4.3 Configuring the serial line for operation

This procedure enables the transmission line parameters to be adapted for interfacing with the control system.

DEFAULT SETTINGS : UNI-TE, RS 485, HDX,
9600 BAUDS, 8 BITS, ODD PARITY,
1 STOP BIT, NO STATUS BLOCK

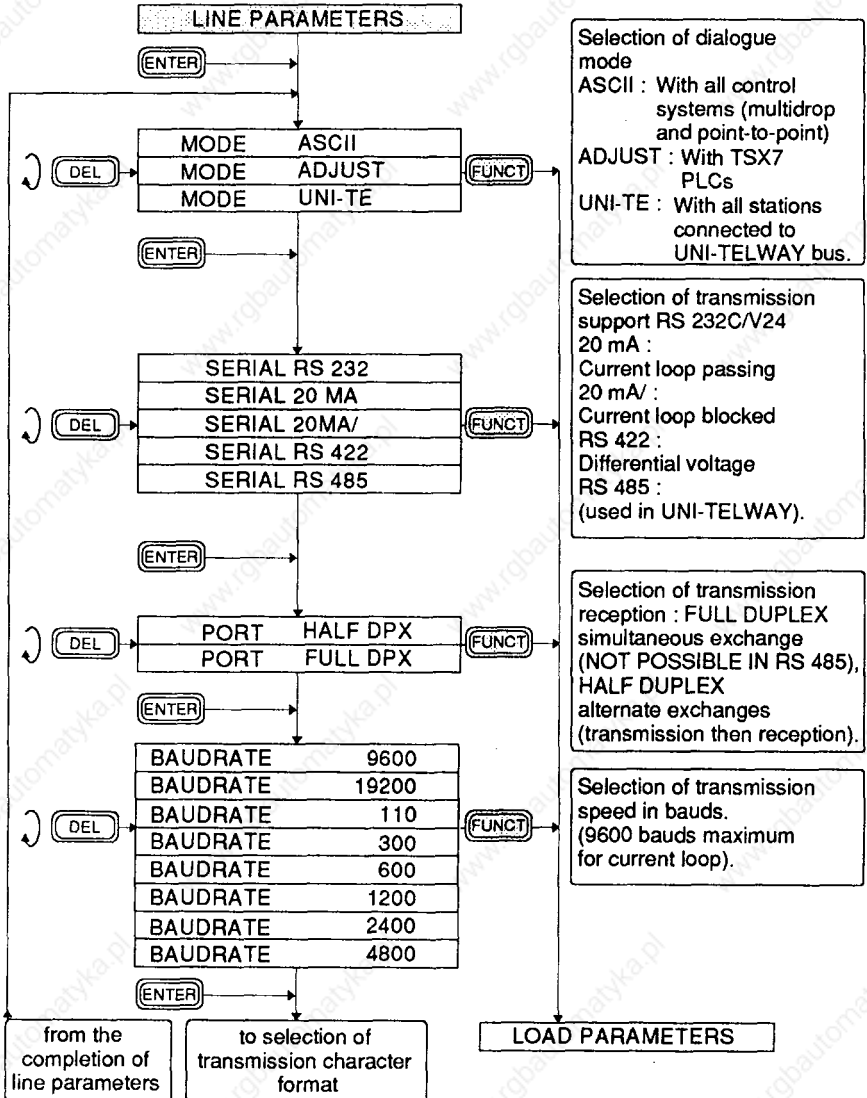

4 Configuration

Configuring the serial line for operation

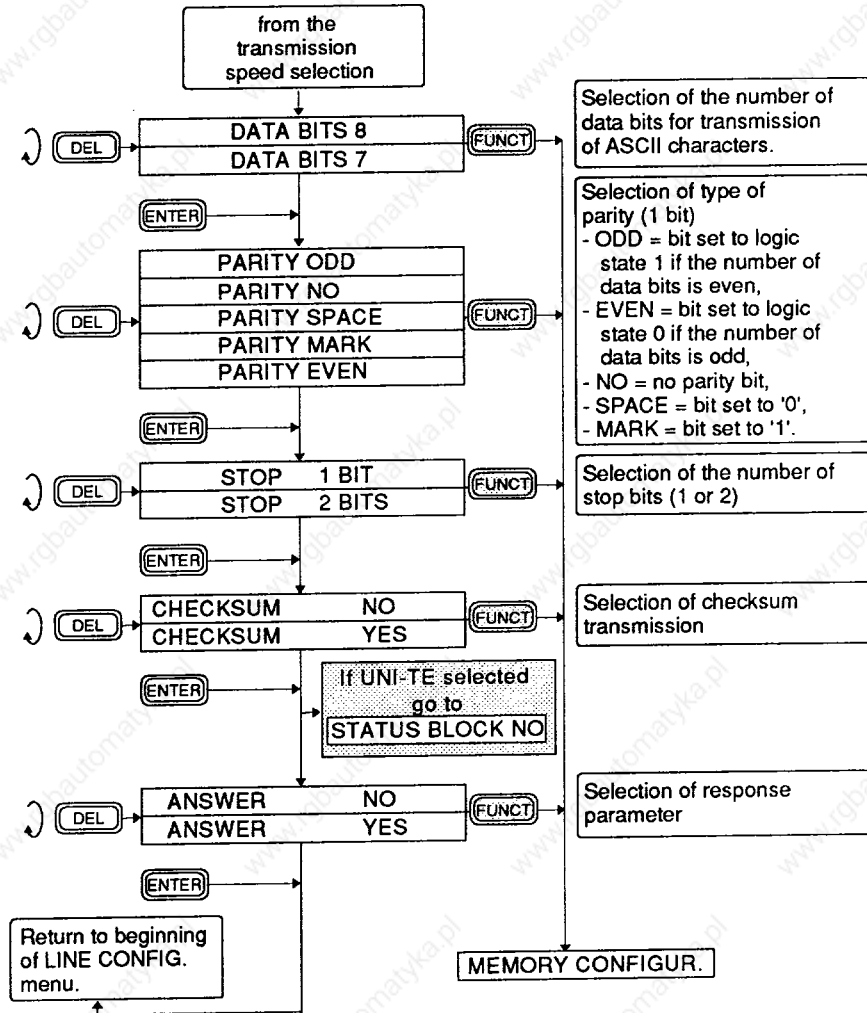

THE FORMAT : 7 BITS, NO PARITY, 1 STOP BIT,
IS NOT ALLOWED

4 Configuration

Configuring the serial line for operation

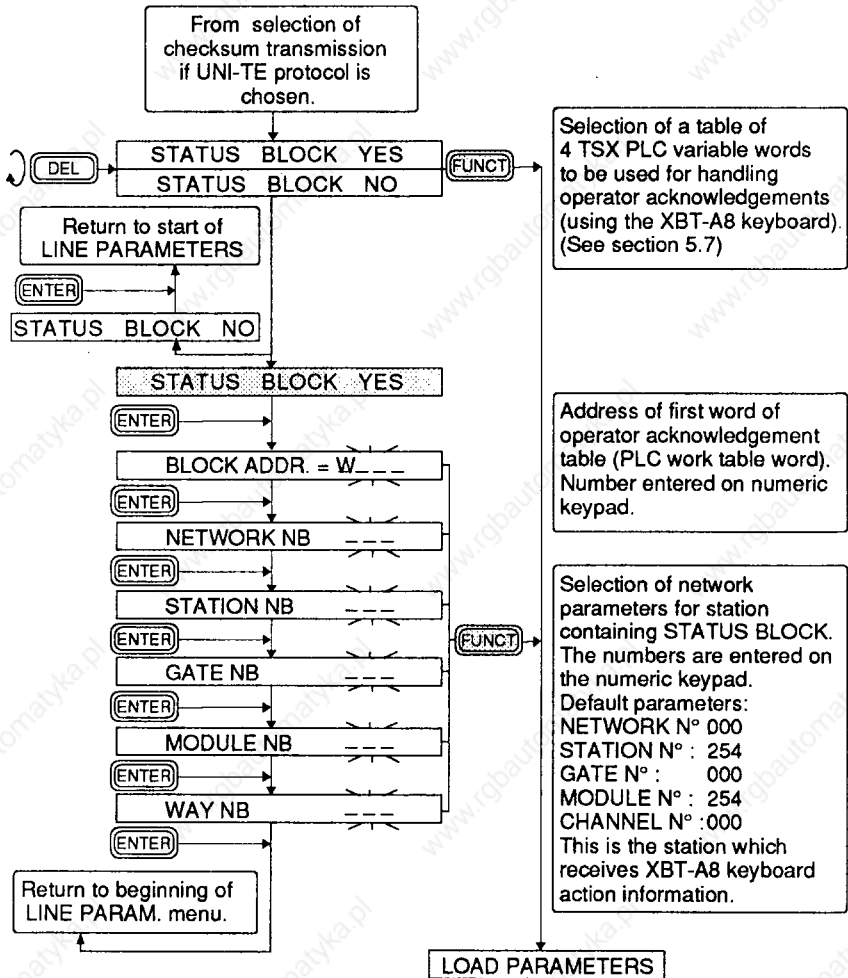

THE PARAMETERS ARE SAVED BY USING

(FUNCT) OR **(ENTER) + (FUNCT)**
(RETURN TO OPERATION)

4 Configuration

4.4 Memory configuration

To store messages in the EEPROM memory of the XBT-A8 you need to connect the serial port to a programming device, which may be :

- a TSX T407 programming terminal (non-conversational storing)
- a video terminal (conversational storing)
- a PC-PS/2 computer, using XBTEL to create and archive programs.

During MEMORY CONFIGURATION the XBT-A8 allows its serial line parameters to be adapted to those of the storing device being used (these parameters are stored independently of those stored during LINE CONFIGURATION. They are protected during a power break).

The procedure for configuring the serial line to store messages is described in the XBT-A users guide (section 4. Memory configuration).

Extract from the MEMORY CONFIGURATION menu

CONVERSATIONAL or NON-CONVERSATIONAL mode may be selected.

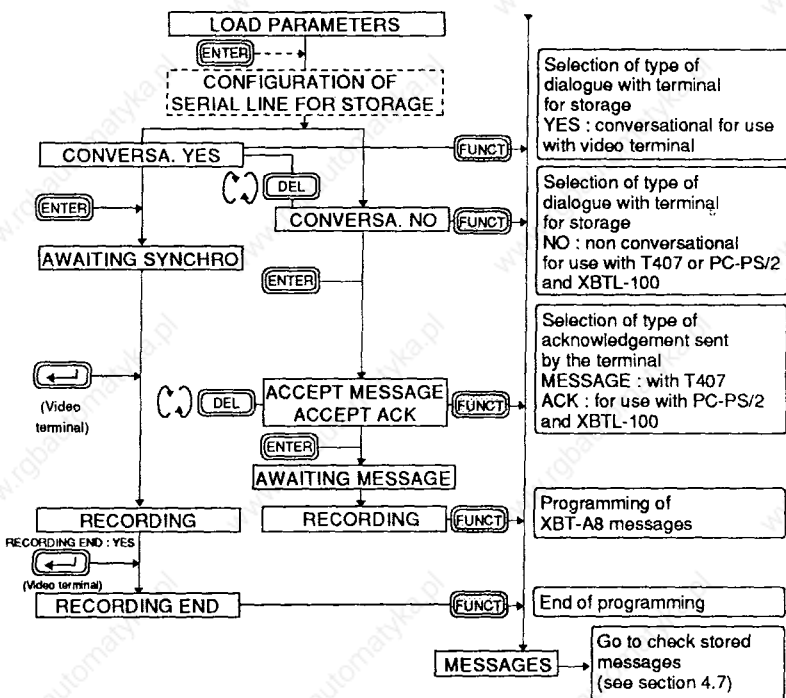

4 Configuration

4.5 Syntax for storing messages

When writing messages to the XBT-A8 memory in conversational mode it is very important to be consistent in selecting parameters.

The most comprehensive message would be stored as follows :

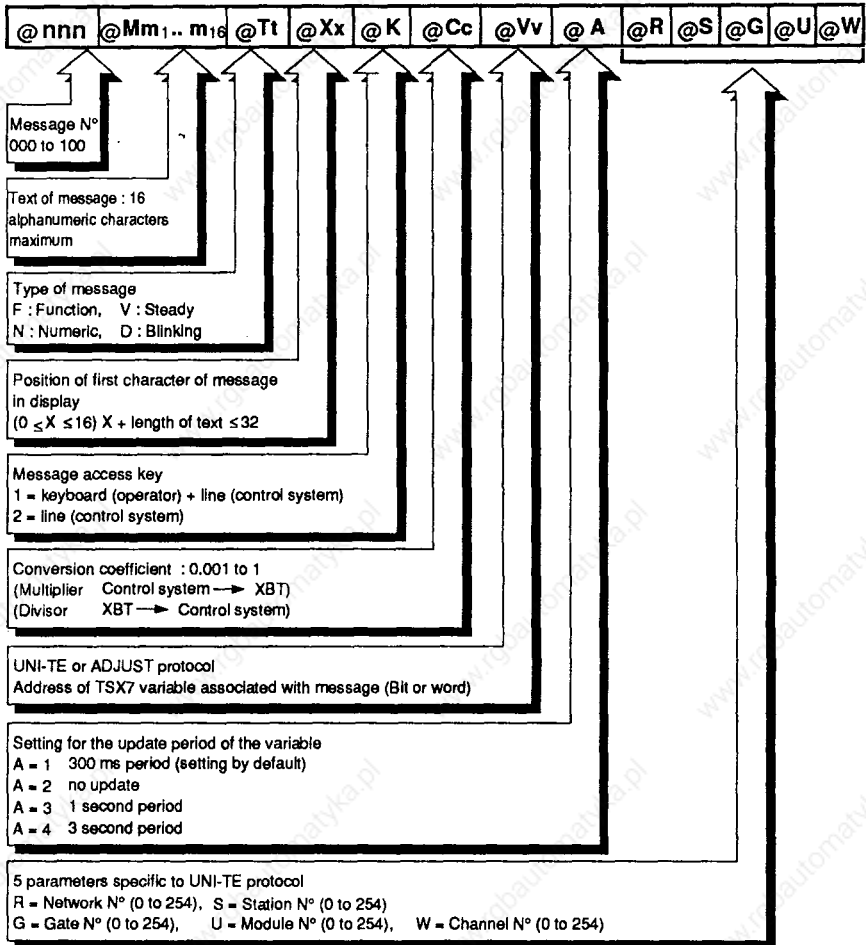

Example : @001@M - - - - @TV



DEFAULT SETTINGS :

TYPE V, X = 00, K = 1, C = 1, no associated variables, A = 2, R = 000,
S = 254, G = 000, U = 254, W = 000

4 Configuration

Syntax for storing messages

• General rules for message composition :

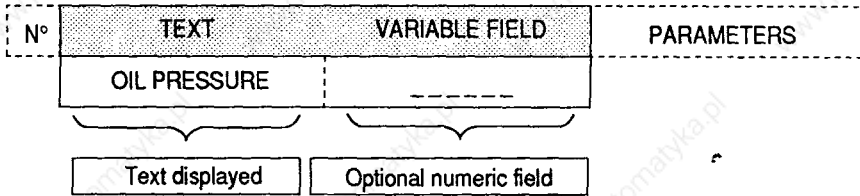

- The length of text and numeric field must not exceed 16 characters.
- The optional numeric field must be represented by - (dashes) (ASCII character 5 F).
- Only ASCII characters 20 to 5F are accepted (lower case characters are refused).
- Decimal points (2E in ASCII) must be used rather than commas (2C in ASCII).

• Special rules for UNI-TE protocol (for use with TSX 7 series PLCs)

• Messages associated with numeric variables :

The numeric field has a maximum length of :

- 6 characters (including the sign) where the conversion coefficient $C = 1$,
- 5 characters (including the sign) where the conversion coefficient $C \neq 1$, or when the TSX 7 PLC variable is a counter, a timer or a monostable,
- 1 digit when the variable associated with the message is a single bit.

Notes :

- Positive values : the + sign is not displayed (it is replaced by a space)
- Negative values : the - sign is displayed.

ALL MESSAGES WHICH INCLUDE A NUMERIC FIELD MUST BE ASSOCIATED WITH A VARIABLE, OTHERWISE THE DASHES IN THE NUMERIC FIELD ARE TREATED AS TEXT AND THE MESSAGE IS TREATED AS A TYPE V MESSAGE WITH NO ASSOCIATED VARIABLE

4 Configuration

Syntax for storing messages.

- Variables which can be accessed

TSX7 PLC VARIABLES		TYPE OF MESSAGE			
DESIGNATION	SYNTAX	F	V	N	D
INTERNAL BIT	Bxxxx	X	X	X	X
INPUT BIT	Ixxx,xx		X		X
OUTPUT BIT	Oxxx,xx		X		X
WORD	Wxxxxx	X	X	X	X
CONSTANT WORD	CWxxxxx		X		X
COMMON WORD	COMxx,x		X		X
TIMER	Txxx,V Txxx,P		V/P	P	X
COUNTER	Cxxx,V Cxxx,P		V/P	P	X
MONOSTABLE	Mxxx,V Mxxx,P		V/P	P	X
DRUM CONTROLLER	Dxxx,V		X		X

X = allowed, V = Current value, P = Preset value.

Note : The designer must adapt syntax limits for the TSX7 variables depending on the PLCs connected to the UNI-TELWAY bus. (Refer to the programming and user manuals for TSX7 PLCs).

4 Configuration

Syntax for storing messages

When an XBT-A8 is connected to the UNI-TELWAY bus, the syntax for storing messages must include five parameters defining a UNI-TELWAY address. This is the address for the SERVER device indicated by the TSX7 variable associated with the message.

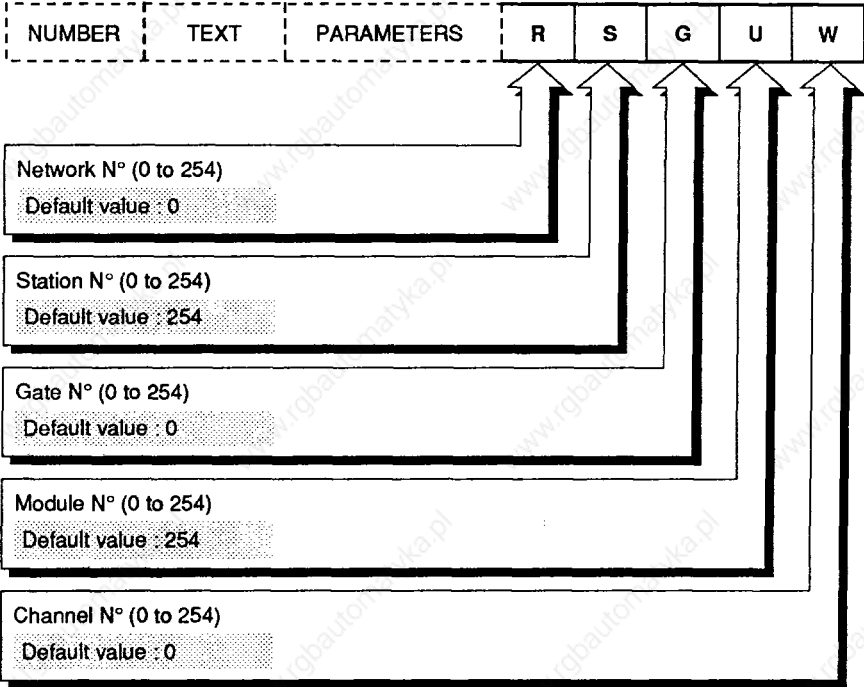

4 Configuration

Syntax for storing messages

- Compatibility

COMPATIBILITY TABLE																							
TYPE	TEXT																COL	Access	COEF	VARIABLE	UPD.	COMMENTS	
	1	2	3	4	5	6	7	8	9	10	11	12	13	14	15	16	X	K	C	V	A		
FUNCTION F																	0 to 32	1	1	BIT		Writes a bit to 1 when operator presses key. Message is displayed. Set to 0 on release.	
																			1	1	BIT		Bracket function (writing to a bit without display).
																		0 to 32	1	1	WORD		Operator responds with function key associated with V type message without variable (writing key code to the word).
STEADY DISPLAY V																	0 to 32	1 or 2	1			Text displayed.	
																	0 to 32	1 or 2	1	ALL OBJECTS (except bits)	1 or 2 or 3 or 4	Text and numeric value of variable displayed.	
																	0 to 32	1 or 2	0.001 to 1	ALL OBJECTS (except bits)	1 or 2 or 3 or 4	Text and numeric value of variable displayed.	
																	0 to 32	1 or 2	1	BIT	1 or 2 or 3 or 4	Text and state of bit (0 or 1) displayed.	
NUMERIC N																	0 to 32	1 or 2	1	ALL OBJECTS (except bits)	1 or 2 or 3 or 4	Text and value of variable displayed. Value can be modified using keyboard.	
																	0 to 32	1 or 2	0.001 to 1	ALL OBJECTS (except bits)	1 or 2 or 3 or 4	Text and value of variable displayed. Value can be modified.	
																	0 to 32	1 or 2	1	BIT	1 or 2 or 3 or 4	Text and state of bit (0 or 1) displayed.	
BLINKING DISPLAY D																	0 to 32	1 or 2	1	ALL OBJECTS (except bits)	1 or 2 or 3 or 4	Text and numeric value of variable displayed blinking.	
																	0 to 32	1 or 2	0.001 to 1	ALL OBJECTS (except bits)	1 or 2 or 3 or 4	Text and numeric value of variable displayed blinking.	
																	0 to 32	1 or 2	1	BIT	1 or 2 or 3 or 4	Text and state of bit (0 or 1) displayed blinking.	
																	0 to 32	1 or 2	1			Text displayed blinking.	

4 Configuration

4.6 Storing messages using a PC-PS/2 computer

XBTEL can be used with a PC-PS/2 computer to store messages (and parameters). The following services are provided :

- Creation of an application in local mode in the RAM memory of the PC-PS/2 and archiving (to diskette or hard disk),
- Transfer of an application to one or several terminals,
- Saving an existing application,
- Comparison of an application (PC-PS/2 RAM with XBT memory),
- Printing an application dossier.

• Creation

In addition to a table for selecting the language, XBTEL displays a table for writing messages and parameters.

The messages are automatically saved every 20 minutes or at the request of the user.

• Transfer

In order to transfer an application to the XBT-A8 terminal or from the XBT to the PC-PS/2, the following must be set up :

- 1 - A n RS 232C connection between the PC-PS/2 computer (SERIAL PORT 1, 2 and 3) and the XBT-A8. Please refer to the section on CONNECTIONS.
- 2 - The transmission parameters between the XBT-A8 terminal and the PC-PS/2 computer by configuring the serial line.

**ONLY THE RS 232 STANDARD MAY BE USED.
ANY OTHER TYPE OF CONNECTION ABSOLVES TELEMECANIQUE
FROM THE TERMS OF THE GUARANTEE IN THE EVENT OF DAMAGE**

In order to configure the computer port, select TRANSFER RAM PC-PS/2 → XBT and adjust the parameters (speed, format, parity and stop) in line with those in the XBT-A8 terminal.

Start the transfer operation, which is then carried out automatically.

• Comparison

A comparison can be made between the application in the XBT-A8 and an application resident in the PC-PS/2.

• Printing

Printing is requested from the TRANSFER menu of the XBTEL software:

- 1 - From the PC-PS/2 to the printer : Select RAM PC-PS/2 → PRINTER, choose the parameters and then start the operation.
- 2 - From the XBT-A8 to the printer via the PC-PS/2 : Select XBT → PRINTER, choose the parameters and then start the operation.
A serial or parallel printer may be used.

4.7 Checking the stored messages

This procedure is used to check to stored messages stored in the EEPROM memory of the XBT-A8 terminal.

The messages are accessed :

- Automatically, incremented by the XBT-A8 after each checking procedure,
- By entering the desired number when MES NUMBER = XXX appears.

IF THE SELECTED MESSAGE DOES NOT EXIST,
MESSAGE ABSENT IS DISPLAYED

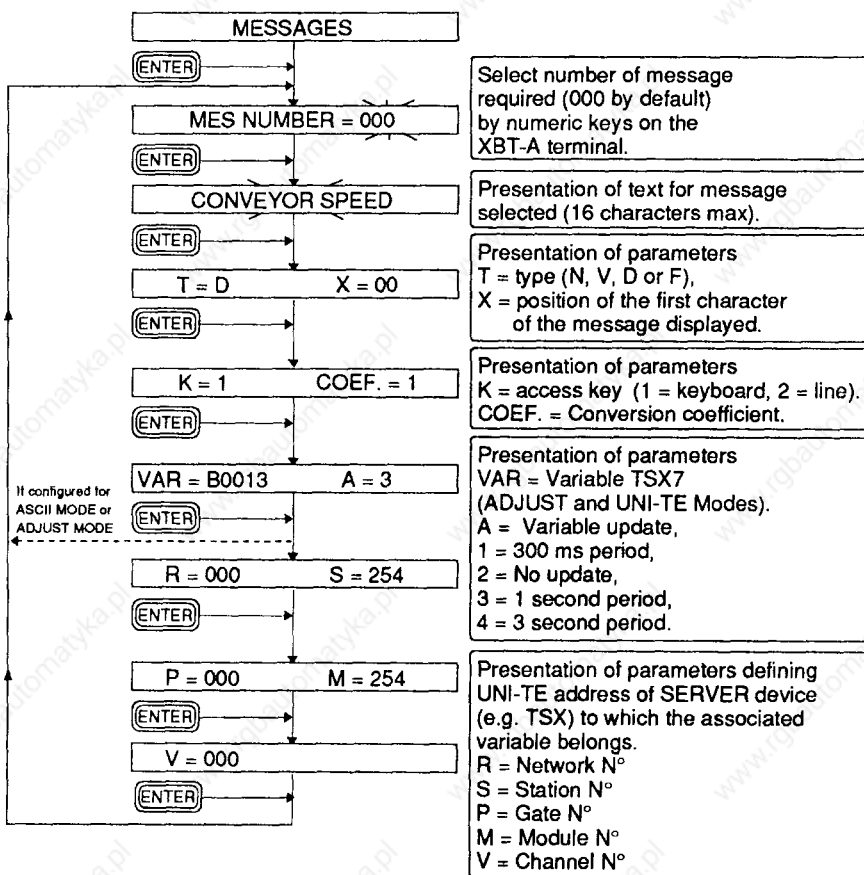

PRESS FUNCT AT ANY TIME
TO START TERMINAL TEST SEQUENCE

5.1 Introduction

• UNI-TE protocol

UNI-TE is the application layer of the UNI-TELWAY industrial communication protocol.

• Introduction

UNI-TELWAY is a multidrop industrial bus which is the standard means of communication between the various products in the Telemecanique range. UNI-TELWAY is also used for communication with devices such as supervision systems and management computers. Physical, data link, network and application layers conform to the I.S.O. specifications of the O.S.I. model. *

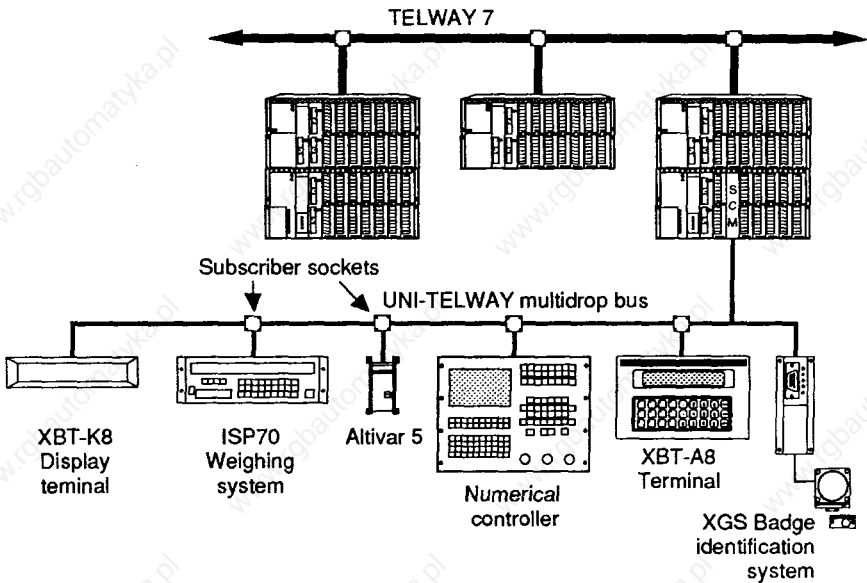

• Principle

UNI-TELWAY requires :

- at the data link level, a fixed master (e.g. TSX7 PLC) which manages and checks communication exchanges (XBT-A8 cannot be a master).
- at the application layer level, 1 to 27 slave devices which may be either CLIENTS or SERVERS, depending on their status with respect to the data link layer.

THE CLIENT ASKS THE SERVER A QUESTION,
THE SERVER REPLIES TO THE CLIENT'S QUESTION

* O.S.I. : Open System Interconnect
I.S.O. : International System Organization

General

• XBT-A8 UNI-TELWAY

- XBT-A8 terminals operating with UNI-TE support all the ADJUST mode functions (when connected to a programming port) and also have the following advantages :
 - Programming terminal ports of the TSX7 PLCs are freed,
 - Terminals operate in multidrop with other devices connected to the bus,
 - Remote devices can be accessed via a Telemecanique network architecture (TELWAY 7, UNI-TELWAY, MAPWAY, etc.).

THE ADDRESS SYSTEM IS DESCRIBED IN THE
UNI-TELWAY BUS "REFERENCE GUIDE" TSX D24004E

• Status of the XBT-A8

- XBT-A8s are SLAVES at the DATA LINK LAYER,
- XBT-A8s may be CLIENTS or SERVERS at the APPLICATION LAYER.

XBT-A8 CLIENT

NO APPLICATION PROGRAM IN THE SERVER DEVICES (e.g. : TSX7)

XBT-A8 SERVER :

REQUESTS PROGRAMMED IN THE CLIENT DEVICES (e.g. : TSX7)

• Communication protocol management

THE XBT-A8 OCCUPIES TWO ADDRESSES ON THE UNI-TELWAY BUS

SERVER ADDRESS : This is the address used by CLIENT control systems for sending their requests to the XBT-A8 terminal.

This address is defined by :

- With the XBT-A in point-to-point (e.g. TSX ↔ XBT-A) address 1 is coded by the connection cable, for example on the TSX side within the 25-pin connector
- With the XBT-A connected to a subscriber socket (e.g. TSX SCA62) the address is coded by the SCA62 micro-switches.

CLIENT ADDRESS : This address is used by the XBT-A8 for sending messages to SERVER devices. It is transparent to the user.

CLIENT ADDRESS = SERVER ADDRESS + 1

Note : These two addresses are independent to those specified in the XBT-A8 configuration for the to message variables or the STATUS BLOCK (see section 4 CONFIGURATION MODE).

These 2 addresses are those of the XBT-A8 itself.

5.2 Function modes

• XBT-A8 SERVER

The XBT-A8 is called a SERVER when it responds to a command given by a CLIENT device.

CLIENT devices request XBT-A8 services by sending standard UNI-TE requests (via TSX7 text blocks).

TYPES OF REQUEST	XBT-A8 FUNCTIONS
GENERAL USE	<ul style="list-style-type: none">- IDENTIFYING EQUIPMENT- PROTOCOL VERSION- STATUS (STATE OF THE TERMINAL)- MIRROR- READING ERROR COUNTERS- RESETTING ERROR COUNTERS
WORKING MODES	<ul style="list-style-type: none">- INITIALIZATION
ACCESS TO DATA (XBT-A8 RESOURCES) read/write bits/words list of bits/list of words	<ul style="list-style-type: none">- MANAGEMENT OF XBT RESOURCES (LEDS, keyboard, buzzer)- DISPLAYING MESSAGES (PREDEFINED OR NOT)- READING PREDEFINED MESSAGES- HANDLING OPERATOR REPONSES
MANAGEMENT OF SEMAPHORES	<ul style="list-style-type: none">- RESERVATION- DERESERVATION- RENEWING THE RESERVATION
FILE TRANSFER	REMOTE UPLOADING/DOWNLOADING (message area)

5 Communication

Function modes

Examples of the XBT-A8 as a SERVER

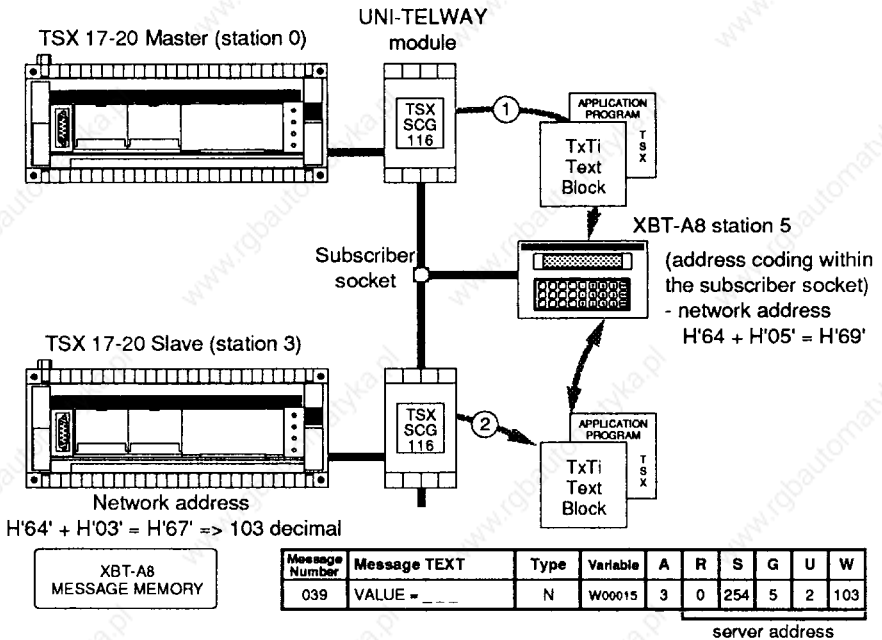

① Modifying a parameter

- The TSX 17-20 master requests that message 039 (H'0027) be displayed with the operator response (Type N). XBT-A8 acts as SERVER,
- The XBT-A8 displays the following : VALUE = _ _ _ _ and the value of the variable W00015 read from station 3 blinks,
- The operator enters his response and confirms it by pressing **(ENTER)** ,
- The XBT-A8 writes the new value to variable W00015 in station 3 and updates it on the display (A=3) every second.

② Inhibiting access to the configuration mode

- The TSX 17-20 slave requests that the XBT-A8 keyboard be locked (inhibiting using the **(ENTER)** plus **(FUNCT)** key combination.),
- XBT-A8 resource address, H'0384' (see section 5.5),
- The XBT-A8 carries out the operation requested.

5 Communication

Function modes

CLIENT TEXT BLOCK			
	CONFIGURATION	TRANSMISSION TABLE	RECEPTION TABLE
①	TSX7 MASTER		
	TYPE : Local EXCHG		
	REQUEST : TxTi,C = H'0714' (write word)	(XBT-A display address) H'0191'	TxTi,R = H'00FE'
	DESTINATION : TxTi,M = H'0069' (XBT-A server)	(Message N°) H'0027'	
	TRANSMISSION : TxTi,L = 4 (length 4 bytes)		
②	TSX7 SLAVE (station 3)		
	TYPE : Local EXCHG	H'00' (R) H'00'	TxTi,R = H'00FE'
	REQUEST : TxTi,C = H'0710' (write bit)	H'05' (G) H'FE' (S)	
	SENDER ADDRESS : TxTi,M = H'0168' (AD1= 1)	H'69' (W) H'02' (U)	
		H'03' H'84'	
	TRANSMISSION : TxTi,L = 10 (length 10 bytes)	H'00' H'00'	

Note : For information on programming text blocks the reader should refer to the relevant TSX7 PLC manual.

5 Communication

Function modes

- **XBT-A8 as a CLIENT**

TYPES OF REQUEST	XBT-A8 FUNCTIONS
DATA ACCESS (e.g. : TSX) Read / write objects (bits / words / list of bits / list of words) of the devices connected	FUNCTION KEYS (associated with the messages stored in the XBT-A8 which has UNI-TE addressing)

Storing messages in the XBT-A8 :

- Direct access
 - The key number on the XBT-A8 (Nos. 1 to 12) corresponds to the message number (Nos. 001 to 012) with its associated variable,
- Indirect access, using **(FUNCT)** key together with a number between 13 and 99,
 - The type of dialogue (types V, N or D) with the TSX 7 variable.
 - The server device (Network, Station, Gate, Module, Channel) e.g. : TSX.

Pressing the function keys associated with the XBT-A8 messages causes the following to occur, in a way which is transparent to the application :

- The message is displayed (XBT-A8 behaves as a SERVER),
- A request is made to read (type V, D, N) or to write (type F, N) the variable (XBT-A8 behaves as a CLIENT).

Function modes

Examples of the XBT-A8 as a CLIENT

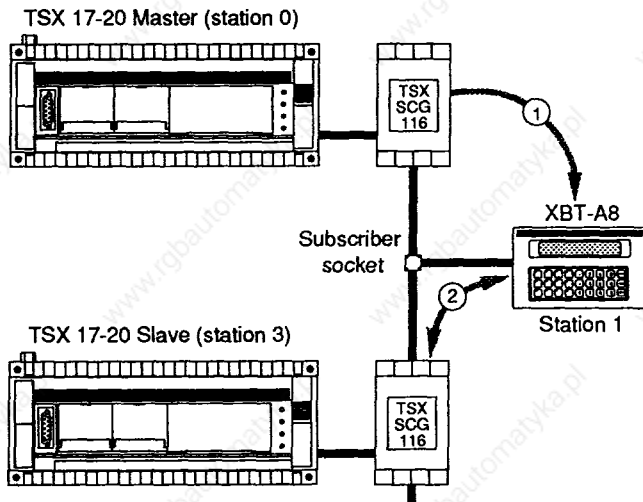

- ① Modifying a parameter :
- Pressing **(F7)** gives access to message N° 007,
 - The text **QUANTITY = ---** is displayed.
 - The value of variable **W00210** in the Master TSX17 is read and is displayed blinking.
 - The operator enters his response and confirms it with **(ENTER)** which causes the new value to be written to variable **W00210** in the TSX17-20 master.
- ② Sending commands (a working mode) :
- Pressing **(F12)** causes the word "AUTOMATIC" to be displayed,
 - Bit **B0077** is set to 1 in the TSX17-20 slave (station 3 : address $H'67' = H'64' + H'03' = 103$ decimal),
 - Releasing **(F12)** causes the display to clear and sets bit **B0077** to 0.

XBT-A8 MESSAGES											
	OBJECTIVE	SERVER	N°	TEXT	TYPE	TSX7 VARIABLE	SERVER ADDRESS				
							R	S	G	U	W
①	Modification	TSX 17 Master	007	QUANTITY ---	N	W00210	0	254	0	254	0
②	Control	TSX 17 Slave	012	AUTOMATIC	F	B0077	0	254	5	0	103

NO TSX17-20 APPLICATION PROGRAM IS NEEDED

5.3 UNI-TE requests

- **Conventions used in the diagrams**

In this section, which describes the UNI-TE requests, the following conventions are used in the diagrams :



represents 1 byte



represents 1 word of 16 bits or 2 bytes

- **General**

Communication taking place essentially by a system of questions and answers called REQUESTS and CONFIRMATION REPORTS.

- **Request format**

- A request consists of :

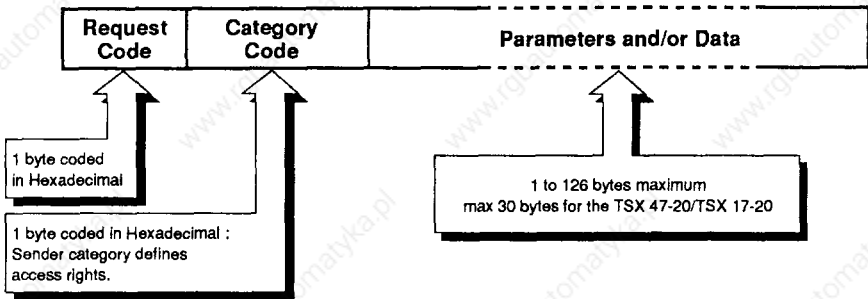

- **Confirmation report format**

- A confirmation report consists of :

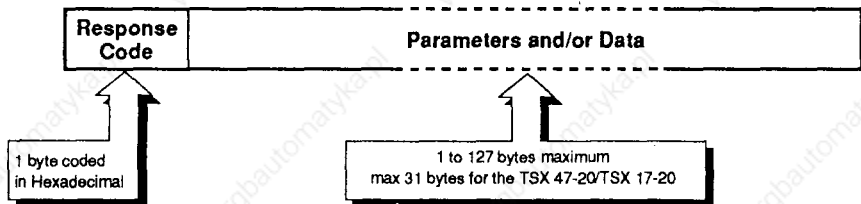

- **Negative response**

The XBT-A8 may send a negative response if the syntax of the request is incorrect.

The negative response code is the same for all requests.

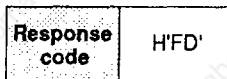

5 Communication

UNI-TE requests

- Using a text function block

TSX master PLC

The application program for the CLIENT master PLC sends the request by using a text function block. This text block (written in the language selected by the user ; in Literal : EXCHG to "LADDER" S, I, O for requests which need a confirmation report), must include all the request parameters.

The relationships between the request/confirmation report structure and the text block parameters are as follows :

Transmission

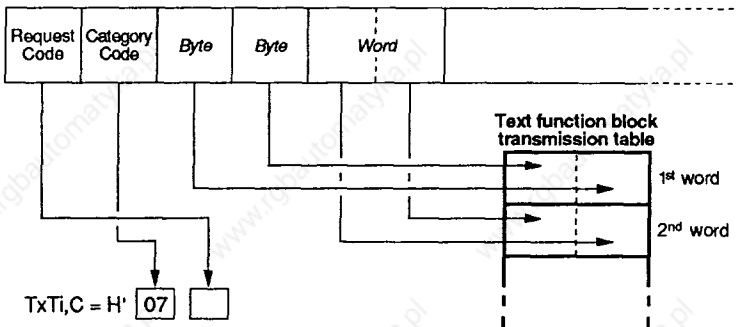

Example : Write objects request = H'37'
TxTi,C = H'0737'

Comment : The category code must always be H'07" (for TSX7s).

TxTi,M Consists of the physical location of the TSX SCM 21 module in the TSX master (for TSX47, 67, 87 PLCs), followed by the target communication address (coded in Hexadecimal) plus H'64'.

TxTi,M =

Rack N°	Target communication address + H'64'
---------	--------------------------------------

Example TxTi,M = H'0365' corresponds to the master module (TSX SCM 21) installed in rack 0 slot 3 and is addressed to the XBT-A8 at communication address 1 (H'01' + H'64').

TxTi,L This is the length of the transmission table (in bytes) containing the parameters and/or data.

5 Communication

UNI-TE requests

Reception

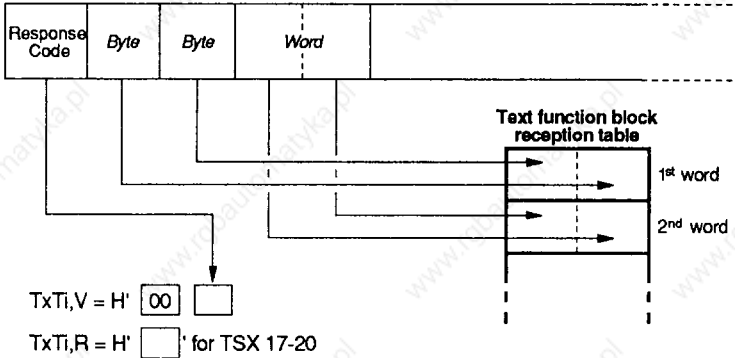

The value is updated after reception

TxTi,S

Consists of the number of bytes received by the text block reception table in the event of successful communication. In the event of faulty communication, TxTi,S has the following values :

- 1 : exchange cancelled by RESET,
- 2 : length of transmission table error,
- 3 : exchange fault (see section 2.8),
- 4 : module fault,
- 5 : parameter error or too many TxTs are active at the same time,
- 6 : message received is longer than allowed,
- 10 : indirect text block address incorrect.

TxTi,D

This bit changes to state 1 when the text block exchange is complete.

TxTi,E

This bit changes to state 1 if there is an exchange error.

UNI-TE requests

PLC slave

A PLC slave (CLIENT) sends a request by using a text function block in the application program. This text block (written in the language selected by the user ; in Literal : EXCHG, to "LADDER" S, I, O for requests which need a confirmation report) must include all the request parameters.

If a PLC slave is the CLIENT, it must specify the target communication address when the request is sent. This address, coded in 5 bytes, must be inserted at the **start** of the text block transmission table.

The relationship between the structure of a request/confirmation report and the text block parameters are as follows :

Transmission on Ad1

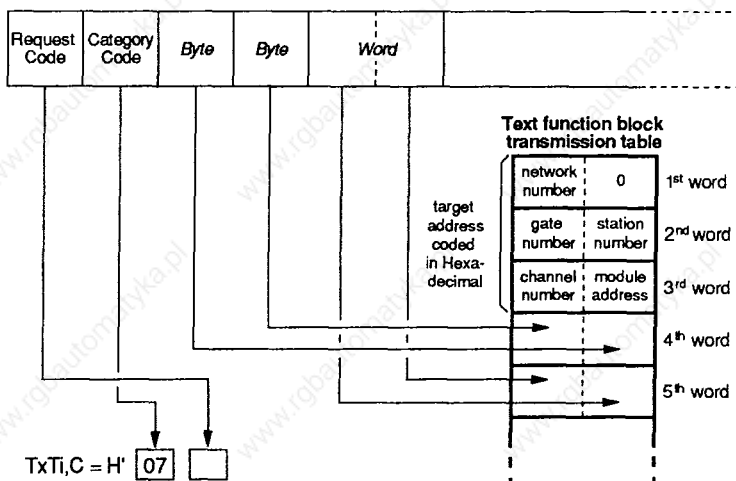

Example : Request to read a message which is being displayed.

XBT-A8 = H'36'

TxTi, C = H'0736

TxTi,M

The address of the sender consists of the physical location of the slave PLC in the TSX SCM 21 module, followed by the **origin** communication address Ad1 (coded in Hexadecimal) plus H'64'.

TxTi,M =	Rack N°	Target communication address + H'64'
----------	---------	--------------------------------------

Example : TxTi,M = H'066B' corresponds to the slave module installed in rack 0, slot 6. The message sender has the communication address 7 (corresponding to Ad1) (H'07' + H'64' = H'6B').

TxTi,L

This is the length of the transmission table (in bytes), including the target address.

5 Communication

UNI-TE requests

Reception at Ad1

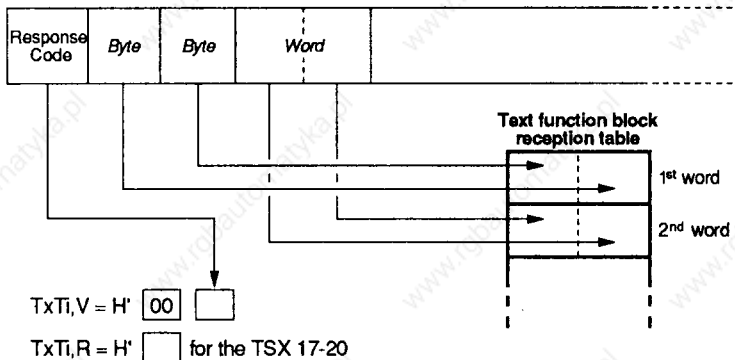

TxTi,S

Consists of the number of bytes received by the text block reception table in the event of successful communication. In the event of faulty communication, TxTi,S has the following values :

- 1 : exchange cancelled by RESET,
- 2 : length of transmission table error,
- 3 : exchange fault (see section 2.8),
- 4 : module fault,
- 5 : parameter error or too many TxTs are active at the same time,
- 6 : message received is longer than allowed,
- 10 : indirect text block address incorrect.

TxTi,D

This bit changes to state 1 when the text block exchange is complete.

TxTi,E

This bit changes to state 1 if there is an exchange error.

5.4 General requests

• Device identification request

This request allows the server device to provide in its response, information about the type of product, its software version and commercial reference number.

Request format :

Request code	Sender category code
H'0F'	H'07'

Confirmation report format : Positive response.

Designation	Response code	Type of product	Product variant	Product version	String length	Commercial reference data
Format	1 byte	1 byte	1 byte	1 byte	1 byte	11 bytes
Code	H'3F'	H'1E'	H'28'	H'11'	H'0B'	H'58' H'42' H'54' H'41 H'30'
Comments	-	XBT-A8	Latin version	Software version E.g. V1.1	11 bytes	XBT-A8-1010

Example :

CLIENT TEXT BLOCK																		
CONFIGURATION	TRANSMISSION TABLE	RECEPTION TABLE																
Type : LOCAL EXCHG TxTi, C = H'070F' TxTi, M = H'0069 E.g. : station 5 (XBT-A8 SERVER) TxTi, L = 0 (bytes)		Reception on AD1 <table border="1"> <tbody> <tr> <td>H'28'</td> <td>H'1E'</td> </tr> <tr> <td>H'0B'</td> <td>H'11'</td> </tr> <tr> <td>H'42'</td> <td>H'58'</td> </tr> <tr> <td>H'2D'</td> <td>H'54'</td> </tr> <tr> <td>H'38'</td> <td>H'41'</td> </tr> <tr> <td>H'31'</td> <td>H'5F'</td> </tr> <tr> <td>H'31'</td> <td>H'30'</td> </tr> <tr> <td></td> <td>H'30'</td> </tr> </tbody> </table> TxTi, R = H'3F' (TSX17) or TxTi, V = H'003F'	H'28'	H'1E'	H'0B'	H'11'	H'42'	H'58'	H'2D'	H'54'	H'38'	H'41'	H'31'	H'5F'	H'31'	H'30'		H'30'
H'28'	H'1E'																	
H'0B'	H'11'																	
H'42'	H'58'																	
H'2D'	H'54'																	
H'38'	H'41'																	
H'31'	H'5F'																	
H'31'	H'30'																	
	H'30'																	

Note : This request is always valid, whether the terminal is reserved or not.

5 Communication

General requests

• Request for protocol version

This request allows the client to supply the protocol version for the application which it supports, the maximum message length and the size of the request file. The server returns its own characteristics. This then allows the client to transmit requests in a format and size which are known to both parties.

Request format :

Designation	Request code	Sender category code	Maximum size of message	Length	Version
Format	1 byte	1 byte	1 word	1 byte	1 byte
Code	H'30'	H'07'	Depends on sender	Depends on sender	H'01'
Comments	-	-	Ignored by the XBT-A8	Ignored by the XBT-A8	UNI-TE version supported by the client (ignored by the XBT-A8)

Confirmation report format : Positive response.

Designation	Response code	Maximum size of message	Sequence length	UNI-TE version	Size of request file
Format	1 byte	1 word	1 byte	1 byte	1 word
Code	H'60'	H'00 40'	H'01'	H'10'	H'00 00'
Comments	-	Maximum size of network data frame (type+address+request) which can be processed by the XBT-A8	-	-	Not handled by XBT-A8

Example :

CLIENT TEXT BLOCK												
CONFIGURATION	TRANSMISSION TABLE	RECEPTION TABLE										
TSX7 MASTER Type : LOCAL EXCHG TxTi, C = H'0730' TxTi, M = H'0069' E.g. : station 5 XBT-A SERVER TxTi, L = 4 (bytes)	<table border="1"> <tr> <td>H'..</td> <td>..'</td> </tr> <tr> <td>H'01'</td> <td>H' '</td> </tr> </table>	H'..	..'	H'01'	H' '	<table border="1"> <tr> <td>H'00'</td> <td>H'40'</td> </tr> <tr> <td>H'10'</td> <td>H'01'</td> </tr> <tr> <td>H'00'</td> <td>H'00'</td> </tr> </table> TxTi, R = H'60' (TSX17) or TxTi, V = H'0060'	H'00'	H'40'	H'10'	H'01'	H'00'	H'00'
H'..	..'											
H'01'	H' '											
H'00'	H'40'											
H'10'	H'01'											
H'00'	H'00'											

Note : This request is always valid, whether the terminal is reserved or not.

5 Communication

General requests

• Request for terminal status

The response of the server provides detailed information about the status of the device.

Request format :

Designation	Request code	Sender category code	Required detail
Format	1 byte	1 byte	1 byte
Code	H'31'	H'07'	H'00' à H'02'
Comments	-	-	H'00' = No data H'02' = Program memory checksum H'03' = Memory checksum (messages + configuration)

Confirmation report format : Positive response.

Designation	Response code	Current state	Mask state	Data
Format	1 byte	1 byte	1 byte	1 word
Code	H'61'	b7 b0	H'64'	Depends on required detail byte
Comments	-	b2 = 1 if messages are lost (message checksum error) b5 = 1 terminal awaiting operator response b6 = 1 if no action is being executed (not awaiting response nor updating the variable).	Mask the non-significant bits of the current state	If details required : H'00' = no data H'02' = program memory checksum H'03' = memory checksum (messages + configuration)

Example : Request for terminal status.

Example :

CLIENT TEXT BLOCK						
CONFIGURATION	TRANSMISSION TABLE	RECEPTION TABLE				
TSX7 MASTER Type : LOCAL EXCHG TxTi, C = H'0731' TxTi, M = H'0069' (E.g. : station 5) XBT-A SERVER TxTi, L = 2 (bytes)	<table border="1"> <tr> <td>H'00'</td> <td>H'00'</td> </tr> </table>	H'00'	H'00'	<table border="1"> <tr> <td>H'64'</td> <td>H'40'</td> </tr> </table> TxTi, R = H'61' (TSX17) or TxTi, V = H'0061'	H'64'	H'40'
H'00'	H'00'					
H'64'	H'40'					

General requests

• **Mirror request**

This request tests the system and the communication route.

The XBT-A8 SERVER returns the same sequence of bytes in the confirmation data field as those received in the request data field.

Request format :

Designation	Request code	Sender category code	Data
Format	1 byte	1 byte	n bytes
Code	H'FA'	H'07'	H'48' H'45' H'4C' H'4F'
Comments	-	-	Byte group 126 max 30 max with TSX 47-20/TSX 17-20

Confirmation report format : Positive response.

Designation	Response code	Data
Format	1 byte	n bytes
Code	H'FB'	H'48' H'45' H'4C' H'4F'
Comments	-	Group of bytes sent at the request of the CLIENT (received bytes are re-transmitted)

Example :

CLIENT TEXT BLOCK											
CONFIGURATION	TRANSMISSION TABLE	RECEPTION TABLE									
TSX7 MASTER Type : LOCAL EXCHG TxTi, C = H'07FA' TxTi, M = H'0069' (E.g. : station 5) XBT-A SERVER TxTi, L = 4 (bytes)	<table border="1"> <tr> <td>H'45'</td> <td>H'48'</td> <td rowspan="2">Byte group</td> </tr> <tr> <td>H'4F'</td> <td>H'4C'</td> </tr> </table>	H'45'	H'48'	Byte group	H'4F'	H'4C'	<table border="1"> <tr> <td>H'45'</td> <td>H'48'</td> </tr> <tr> <td>H'4F'</td> <td>H'4C'</td> </tr> </table> TxTi, R = H'FB' (TSX17) or TxTi, V = H'00FB'	H'45'	H'48'	H'4F'	H'4C'
H'45'	H'48'	Byte group									
H'4F'	H'4C'										
H'45'	H'48'										
H'4F'	H'4C'										

Note : There is no negative response.

5 Communication

General requests

- **Request to read error counters (UNI-TELWAY diagnostic)**

Each station keeps a log of the data link errors (errors related to characters, frames or protocol) by counting 4 types of error in 4 counters (16-bit words).

Request format :

Request code	Sender category code
H'A2'	H'07'

Confirmation report format : Positive response

Designation	Response code	Number of messages sent not acknowledged	Number of messages sent refused	Number of messages received not acknowledged	Number of messages received refused
Format	1 byte	1 word	1 word	1 word	1 word
Code	H'D2'	H'0000' to H'7FFF'	H'0000' to H'7FFF'	H'0000' to H'7FFF'	H'0000' to H'7FFF'
Comments	-	Not acknowledged by ACK or NACK	Refused by NACK re-transmitted to XBT-A8	Received not acknowledged by XBT-A8	Refused by NACK re-transmitted by XBT-A8

Note : The counters do not overflow, they remain at the maximum value (32767) until they are reset to zero by a 'Reset counters to zero' request.

Example :

CLIENT TEXT BLOCK										
CONFIGURATION	TRANSMISSION TABLE	RECEPTION TABLE								
TSX7 MASTER Type : LOCAL EXCHG TxTi, C = H'07A2' TxTi, M = H'0069' (E.g. : station 5) XBT-A SERVER TxTi, L = 0 (bytes)		<table border="1"> <tbody> <tr> <td>H'00, 08'</td> <td>8 messages sent not acknowledged</td> </tr> <tr> <td>H'00, 58'</td> <td>88 messages sent refused</td> </tr> <tr> <td>H'00, 24'</td> <td>36 messages received not acknowledged</td> </tr> <tr> <td>H'00, 00'</td> <td>No received messages refused</td> </tr> </tbody> </table> TxTi, R = H'D2' (TSX17) or TxTi, V = H'00D2'	H'00, 08'	8 messages sent not acknowledged	H'00, 58'	88 messages sent refused	H'00, 24'	36 messages received not acknowledged	H'00, 00'	No received messages refused
H'00, 08'	8 messages sent not acknowledged									
H'00, 58'	88 messages sent refused									
H'00, 24'	36 messages received not acknowledged									
H'00, 00'	No received messages refused									

5 Communication

General requests

- **Request to reset error counters to zero**

This request resets the 4 error counters in the XBT-A8 to zero.

Request format :

Request code	Sender category code
H'A4'	H'07'

Confirmation report format : Positive response

Response code	H'FE'
---------------	-------

Example :

CLIENT TEXT BLOCK		
CONFIGURATION	TRANSMISSION TABLE	RECEPTION TABLE
TSX7 MASTER Type : LOCAL EXCHG TxTi, C = H'07A4' TxTi, M = H'0069' (E.g. : station 5) XBT-A SERVER TxTi, L = 0 (bytes)		TxTi, R = H'FE' (TSX17) or TxTi, V = H'00FE' (the 4 counters are reset to zero)

5.5 Requests to access XBT-A8 resources

- Resource addresses

- Bit area

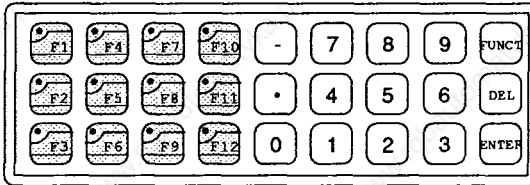

	Number	FUNCTION	XBT ADDRESS		TYPE OF ACCESS	
			Decimal	Hexadecimal	Individually	List of bits
Ctrl of keyboard LEDs LOCKING THE KEYBOARD	1 to 12	Lighting/ extinguishing keyboard LEDs	01 to 12	H'0000' to H'000C'	Write	Write Object
	(F1) to (F12)	Function keys	101 to 112	H'0065' to H'0070'	Write	Write Object
	(0) to (9)	Numeric keys 0 to 9	200 to 209	H'00C8' to H'00D1'	Write	Write Object
	(-)	- Key	210	H'00D2'	Write	
	(FUNCT)	FUNCT key	263	H'0107'	Write	
	(.)	. Key	265	H'0109'	Write	
	(DEL)	DEL key	268	H'010C'	Write	Write Object
	(ENTER)	ENTER key	269	H'010D'	Write	
	LOCKING CONFIGURATION MODE	(ENTER) + (FUNCT)	Locking the combination (ENTER) + (FUNCT)	900	H'0384'	Write
		Start / stop buzzer	901	H'0385'	Write	
CONTROL OF THE BUZZER						

Requests to access XBT-A8 resources

- Word area

	Number	FUNCTION	XBT ADDRESS		TYPE OF ACCESS	
			Decimal	Hexadecimal	Individual	List
KEYBD. ACCESS	9033	Global locking/unlocking of the keyboard	9033	H'2349'	Write	
STORED MESSAGE ACCESS	401	Display a stored message	401	H'0191'	Write	
DISPLAY BUFFER ADDRESS	2001	Read the display buffer (read the displayed message) Write the display buffer (display a message not stored in the XBT-A8)	2001	H'07D1'		Read or Write

NOTE : ALL RESOURCES ACCESSIBLE BY INDIVIDUAL REQUESTS CAN BE ACCESSED BY OBJECT LIST REQUESTS (BIT OR WORD)

5 Communication

Requests to access XBT-A8 resources

• Controlling the keyboard LEDs

The LEDs on the function keys are represented in memory by 12 consecutive bits (addresses 1 to 12 in the bit area).

- On/off

- . The command consists of setting a bit corresponding to the LED to either 0 for off or 1 for on.
- . The command may be for an individual LED or multiple LEDs (consecutive bits).

Individual command : "Write bit" request

Request format :

Designation	Request code	Sender category code	LED number	Confirm 1 or 0
Format	1 byte	1 byte	1 mot	1 byte
Code	H'10'	H'07'	H'000A'	H'01' or H'00'
Comments	Write a bit	-	LED for Function key 	H'01' on H'00' off

Confirmation report format : Positive response

Response code	H'FE'
---------------	-------

Example : Switching on the LED for the  function key.

CLIENT TEXT BLOCK						
CONFIGURATION	TRANSMISSION TABLE	RECEPTION TABLE				
TSX7 MAITRE Type : LOCAL EXCHG TxTi, C = H'0710' TxTi, M = H'0069' (E.g. station 5) XBT-A8 SERVER TxTi, L = 4 (bytes)	<table border="1" style="margin-left: auto; margin-right: auto;"> <tr> <td>H'0A'</td> <td>H'00'</td> </tr> <tr> <td>H'00'</td> <td>H'01'</td> </tr> </table>	H'0A'	H'00'	H'00'	H'01'	TxTi, R = H'FE' (TSX17) or TxTi, V = H'00FE' Positive response
H'0A'	H'00'					
H'00'	H'01'					

5 Communication

Requests to access XBT-A8 resources

Turning the keyboard LEDs on/off (continued)

Individual or multiple command : "Write object" request

Using this request allows the LEDs to be controlled individually (as in the preceding example) or together.

Request format :

Designation	Request code	Sender category	Segment	Reserved	Object address	Number of bits	Data
Format	1 byte	1 byte	1 byte	1 byte	1 word	1 word	1 word
Code	H'37'	H'07'	H'02'	H'00'	H'0001' to H'000C'	H'01' to H'0C'	H'00' to H'FF'
Comments	Write objects	-	Access bit area	-	Address of 1 st bit (1 st function key)	Number of function keys	Starting with the address of the first bit, set the bits to 1 or 0

Comment :

The data is written in 1 or 2 bytes depending on the number of bits to be written (number of LEDs to be controlled).

Confirmation report format : Positive response

Response code	H'FE'
---------------	-------

Example : Switching on the LEDs for the (F1) (F7) (F12) function keys.

CLIENT TEXT BLOCK										
CONFIGURATION	TRANSMISSION TABLE	RECEPTION TABLE								
TSX7 MASTER Type : LOCAL EXCHG TxTi, C = H'0737' TxTi, M = H'0069' (E.g. station 5) XBT-A8 SERVER TxTi, L = 8 (bytes)	<table border="1"> <tbody> <tr> <td>H'00'</td> <td>H'02'</td> </tr> <tr> <td>H'00'</td> <td>H'04'</td> </tr> <tr> <td>H'00'</td> <td>H'0C'</td> </tr> <tr> <td>H'08'</td> <td>H'41'</td> </tr> </tbody> </table>	H'00'	H'02'	H'00'	H'04'	H'00'	H'0C'	H'08'	H'41'	TxTi, R = H'FE' (TSX17) or TxTi, V = H'00FE' Positive response
H'00'	H'02'									
H'00'	H'04'									
H'00'	H'0C'									
H'08'	H'41'									

5 Communication

Requests to access XBT-A8 resources

• Locking/unlocking the keyboard

- The keyboard keys are represented in memory by image bits. The bit addresses are not consecutive so use the "Write object" request when addressing.
- The command to lock or unlock is carried out by setting the image bit corresponding to the key to 1 or 0.
 - . Logic state 0 : key does not function
 - . Logic state 1 : key functions

Individual command : "Write bit" request

Request format :

Designation	Request code	Sender category code	Key number	Confirm 1 or 0
Format	1 byte	1 byte	1 word	1 byte
Code	H'10'	H'07'	H'0067'	H'00' or H'01'
Comments	Write a bit	-	Address of key image bit E.g. (F3)	H'00' locking H'01' unlocking

Confirmation report format : Positive response

Response code	H'FE'
---------------	-------

Example : Locking the (F3) function key.

CLIENT TEXT BLOCK						
CONFIGURATION	TRANSMISSION TABLE	RECEPTION TABLE				
TSX7 MASTER Type : LOCAL EXCHG TxTi, C = H'0710' TxTi, M = H'0069' (E.g. station 5) XBT-A8 SERVER TxTi, L = 4 (bytes)	<table border="1"> <tr> <td>H'00'</td> <td>H'67</td> </tr> <tr> <td>H'00'</td> <td>H'00'</td> </tr> </table>	H'00'	H'67	H'00'	H'00'	TxTi, R = H'FE' (TSX 17) or TxTi, V = H'00FE' Positive response : the (F3) key is locked
H'00'	H'67					
H'00'	H'00'					

5 Communication

Requests to access XBT-A8 resources

Locking/unlocking the keyboard (continued)

Individual or multiple command : "Write object" request.

Request format :

Designation	Request code	Sender category	Segment	Reserved	Object address	Number of bits	Data
Format	1 byte	1 byte	1 byte	1 byte	1 word	1 word	1 word
Code	H'37'	H'07'	H'02'	H'00'	H'0065' to H'0384'	H'0001' to H'000C'	
Comments	Write objects	-	Access bit area	-	Address of 1 st bit	Number of consecutive bits in data field	Starting with the address of the first bit, set the bits to 1 or 0

Comment :

The data field is coded in 1 or 2 bytes depending on the number of keys to be controlled.

Note : The number of bits depends on the address of the 1st bit and the maximum number for the corresponding field (see bit area address table).

If there is an overflow into a non-existent field, the terminal sends a negative response : H'FD'.

Confirmation report format : Positive response

Response code	H'FE'

Example : Locking the numeric keypad (keys to and).

CLIENT TEXT BLOCK										
CONFIGURATION	TRANSMISSION TABLE	RECEPTION TABLE								
TSX7 MASTER Type : LOCAL EXCHG TxTi, C = H'0737' TxTi, M = H'0069' (E.g. station 5) XBT-A8 SERVER TxTi, L = 14 (bytes)	<table border="1"> <tbody> <tr> <td>H'00'</td> <td>H'02'</td> </tr> <tr> <td>H'00'</td> <td>H'C8'</td> </tr> <tr> <td>H'00'</td> <td>H'0B'</td> </tr> <tr> <td>H'00'</td> <td>H'00'</td> </tr> </tbody> </table>	H'00'	H'02'	H'00'	H'C8'	H'00'	H'0B'	H'00'	H'00'	TxTi, R = H'FE' (TSX17) or TxTi, V = H'00FE' Positive response
H'00'	H'02'									
H'00'	H'C8'									
H'00'	H'0B'									
H'00'	H'00'									

5 Communication

Requests to access XBT-A8 resources

• Global control of the keyboard

Locking or unlocking all the keys, except for the **(ENTER)** + **(FUNCT)** combination, (used to access to CONFIGURATION mode) is carried out by writing the value field to address 9033 decimal (H'2349'). This address is accessed in the XBT word area by the "Write word" request.

Request format :

Designation	Request code	Sender category	XBT word address	Value
Format	1 byte	1 byte	1 word	1 word
Code	H'14'	H'07'	H'2349'	H'00 00' or H'FF FF'
Comments	Write a word	-	XBT-A8 keyboard access	H'0000' lock H'FFFF' unlock

Confirmation report format : Positive response

Response code	H'FE'
---------------	-------

Example : Command to unlock all the keys of the XBT-A8 keyboard

CLIENT TEXT BLOCK						
CONFIGURATION	TRANSMISSION TABLE	RECEPTION TABLE				
<p>TSX7 MASTER Type : LOCAL EXCHG TxTi, C = H'0714' TxTi, M = H'0069' (E.g. station 5) XBT-A8 SERVER TxTi, L = 4 (bytes)</p>	<table border="1"> <tr> <td>H'23</td> <td>H'49'</td> </tr> <tr> <td>H'FF</td> <td>H'FF'</td> </tr> </table>	H'23	H'49'	H'FF	H'FF'	<p>TxTi, R = H'FE' (TSX17) or TxTi, V = H'00FE' Positive response</p> <p>All the keyboard keys are unlocked (except the combination (ENTER) + (FUNCT))</p>
H'23	H'49'					
H'FF	H'FF'					

5 Communication

Requests to access XBT-A8 resources

• Controlling the buzzer

The buzzer is controlled by setting the image bit at address 901 (H'0385') in the bit area to 1 or 0.

Use the "Write bit" request command.

Request format :

Designation	Request code	Sender category	Number of buzzer image bit	Bit state
Format	1 byte	1 byte	1 word	1 byte
Code	H'10'	H'07'	H'0385'	H'00' or H'01'
Comments	Write a bit	-	Address of bit in XBT-A8 bit area (901 in decimal)	H'00' = stop H'01' = start

Confirmation report format : Positive response

Response code	
	H'FE'

Example : Command to switch on the buzzer.

CLIENT TEXT BLOCK						
CONFIGURATION	TRANSMISSION TABLE	RECEPTION TABLE				
TSX7 MASTER Type : LOCAL EXCHG TxTi, C = H'0710' TxTi, M = H'0069' (E.g. station 5) XBT-A8 SERVER TxTi, L = 3 (bytes)	<table border="1"> <tr> <td>H'03</td> <td>H'85'</td> </tr> <tr> <td>H'00'</td> <td>H'01'</td> </tr> </table>	H'03	H'85'	H'00'	H'01'	TxTi, R = H'FE' (TSX17) or TxTi, V = H'00FE' Positive response
H'03	H'85'					
H'00'	H'01'					

5 Communication

Requests to access XBT-A8 resources

The XBT-A8 may also be controlled by using a "Write object" request.

Request format :

Designation	Request code	Sender category	Segment	Reserved	Object address	Number of bits	1 byte data
Format	1 byte	1 byte	1 byte	1 byte	1word	1 word	1word
Code	H'37'	H'07'	H'02'	H'00'	H'0385'	H'0001'	H'00' or H'01'
Comments	Write list of objects	-	Access bit area	-	Address of buzzer image bit in bit area	1 bit data field	H'00' = stop H'01' = start

Confirmation report format : Positive response

Response code
H'FE'

Example : Command to switch off the buzzer.

CLIENT TEXT BLOCK										
CONFIGURATION	TRANSMISSION TABLE	RECEPTION TABLE								
TSX7 MASTER Type : LOCAL EXCHG TxTi, C = H'0737 TxTi, M = H'0069' (E.g. station 5) XBT-A8 SERVER TxTi, L = 8 (bytes)	<table border="1"> <tr> <td>H'00'</td> <td>H'02'</td> </tr> <tr> <td>H'03'</td> <td>H'85'</td> </tr> <tr> <td>H'00'</td> <td>H'01'</td> </tr> <tr> <td>H'00'</td> <td>H'00'</td> </tr> </table>	H'00'	H'02'	H'03'	H'85'	H'00'	H'01'	H'00'	H'00'	TxTi, R = H'FE' (TSX17) or TxTi, V = H'00FE' Positive response
H'00'	H'02'									
H'03'	H'85'									
H'00'	H'01'									
H'00'	H'00'									

Requests to access XBT-A8 resources

• **Displaying a message already stored in the XBT-A8**

Displaying a message already stored in the XBT-A8 is carried out by sending a "Write word" request.

Request format :

Designation	Request code	Sender category	Word address	Word value
Format	1 byte	1 byte	1 word	1 word
Code	H'14'	H'07'	H'01 91'	H'0000' to H'0064'
Comments	Write word	-	Address in word space (display address : 401 decimal)	Number of message to display from 000 to 100

Confirmation report format :

There is a negative response if :

- question syntax is incorrect,
- there is no message stored in the XBT-A8 at the number requested,
- the message is type F with associated bit variable.

	Positive	Negative
Response code	H'FE'	H'FD'

Example : Request to display message number 043 stored in the XBT-A8.

CLIENT TEXT BLOCK						
CONFIGURATION	TRANSMISSION TABLE	RECEPTION TABLE				
TSX7 MASTER Type : LOCAL EXCHG TxTi, C = H'0714' TxTi, M = H'0069' (E.g. station 5) XBT-A8 SERVER TxTi, L = 4 (bytes)	<table border="1"> <tr> <td>H'01</td> <td>H'91'</td> </tr> <tr> <td>H'00</td> <td>H'2B'</td> </tr> </table>	H'01	H'91'	H'00	H'2B'	TxTi, R = H'FE' (TSX17) or TxTi, V = H'00FE' Positive response
H'01	H'91'					
H'00	H'2B'					

Comments :

On receipt of this request :

- If a TSX7 variable is associated with the message, the XBT-A8 will read it and the value will be written in the numeric field of the message. If the parameter (A) "update the variable" is ≠ 2, the XBT-A8 will read the variable at set intervals.
- If there is no associated variable, only the text is displayed.

5 Communication

Requests to access XBT-A8 resources

Displaying a message already stored in the XBT-A8 (continued)

Use of the "Write object" request.

(The operation is the same for using the "Write word" request.)

Request format :

Designation	Request code	Sender category	Segment	Reserved	Object address	Number of bytes to write	Data
Format	1 byte	1 byte	1 byte	1 byte	1word	1 word	1word
Code	H'37'	H'07'	H'01'	H'00'	H'0191'	H'0001'	H'00 00' to H'00 64'
Comments	Write objects	-	Access word area (physical address of words)	-	Address in word area (address of display : 401decimal)	1 word only to write	Number of message to display : from 000 to 100

Confirmation report format : Positive response

Response code	H'FE'
---------------	-------

Example : Request to display message number 028 stored in the XBT-A8.

CLIENT TEXT BLOCK										
CONFIGURATION	TRANSMISSION TABLE	RECEPTION TABLE								
TSX7 MASTER Type : LOCAL EXCHG TxTi, C = H'0737' TxTi, M = H'0069' (E.g. station 5) XBT-A8 SERVER TxTi, L = 8 (bytes)	<table border="1"> <tr><td>H'00'</td><td>H'01'</td></tr> <tr><td>H'01'</td><td>H'91'</td></tr> <tr><td>H'00'</td><td>H'01'</td></tr> <tr><td>H'00'</td><td>H'1C'</td></tr> </table>	H'00'	H'01'	H'01'	H'91'	H'00'	H'01'	H'00'	H'1C'	TxTi, R = H'FE' (TSX17) or TxTi, V = H'00FE' Positive response
H'00'	H'01'									
H'01'	H'91'									
H'00'	H'01'									
H'00'	H'1C'									

5 Communication

Requests to access XBT-A8 resources

• Displaying a message not stored in the XBT-A8

A message which is not stored in the XBT-A8 memory may be displayed if it is transferred into the terminal display buffer.

The UNI-TE request used is the "Write object" request, which allows a string of bytes to be written into the XBT-A8 display buffer.

Request format :

Designation	Request code	Sender category	Segment	Reserved	Object address	Number of objects to write	Data
Format	1 byte	1 byte	1 byte	1 byte	1 word	1 word	64 bytes max
Code	H'37'	H'07'	H'01'	H'00'	H'07D1'	H'0001' to H'0020'	H'xx'....H'xx'
Comments	Write objects.	-	Access word area (physical address of words)	-	Address of XBT-A8 display buffer (in word area) : 2001 (decimal)	Number of words to write to display buffer 1 to 32 words of 32 characters max + 32 dec. points	Text to display 64 characters max (64 bytes) (32 characters + 32 decimal points)

There must always be an even number of data.

Confirmation report format : Positive response

Response code
H'FE'

Example : Request to display the message

 STOP PUMP 15

CLIENT TEXT BLOCK																						
CONFIGURATION	TRANSMISSION TABLE	RECEPTION TABLE																				
TSX7 MASTER Type : LOCAL EXCHG TxTi, C = H'0737' TxTi, M = H'0069' (E.g. station 5) XBT-A8 SERVER TxTi, L = 20 (bytes)	<table border="1"> <tr><td>H'00'</td><td>H'01'</td></tr> <tr><td>H'07'</td><td>H'D1'</td></tr> <tr><td>H'00'</td><td>H'08'</td></tr> <tr><td>H'53'</td><td>H'20'</td></tr> <tr><td>H'4F'</td><td>H'54'</td></tr> <tr><td>H'20'</td><td>H'50'</td></tr> <tr><td>H'55'</td><td>H'50'</td></tr> <tr><td>H'50'</td><td>H'4D'</td></tr> <tr><td>H'31'</td><td>H'20'</td></tr> <tr><td>H'20'</td><td>H'35'</td></tr> </table> Object addr. segment 7 words to write (Number of objects) Message text	H'00'	H'01'	H'07'	H'D1'	H'00'	H'08'	H'53'	H'20'	H'4F'	H'54'	H'20'	H'50'	H'55'	H'50'	H'50'	H'4D'	H'31'	H'20'	H'20'	H'35'	TxTi, R = H'FE' (TSX17) or TxTi, V = H'00FE' Positive response : the message " <u> </u> STOP PUMP <u> </u> 15 <u> </u> " is displayed
H'00'	H'01'																					
H'07'	H'D1'																					
H'00'	H'08'																					
H'53'	H'20'																					
H'4F'	H'54'																					
H'20'	H'50'																					
H'55'	H'50'																					
H'50'	H'4D'																					
H'31'	H'20'																					
H'20'	H'35'																					

Requests to access XBT-A8 resources

Rules for writing :

- Characters which can be displayed on the XBT-A8 :
All characters from H'20' to H'5F' inclusive. The XBT-A8x1019 can also display cyrillic characters (codes H'60' to H'7E') (see Appendices : Table of characters which can be displayed).

WARNING : AN XBT-A8x1019 CANNOT DISPLAY CYRILLIC CHARACTERS UNLESS IT IS CONFIGURED IN RUSSIAN (See section 4.2 : Configuring the languages)

- Decimal points (character H'2E') are displayed in the same position as the digit which precedes them. This has to be taken into account when composing the messages for display.

- **Use of the NUL control character (H'00')**

NUL CANNOT BE DISPLAYED. IT IS USED ONLY AS A CURSOR CONTROL CHARACTER

Example : After an unexpected stoppage, a plant may not be started up again in a normal cycle until it has been checked and initialized by going through an "adjustment cycle".

When selecting the "adjustment cycle", the control system sends a "Write object" request to the XBT-A8. This causes the following text, which is not stored in the XBT, to be displayed, starting at the first position at the left of the display unit : "ADJUST".

CLIENT TEXT BLOCK			
CONFIGURATION	TRANSMISSION TABLE		RECEPTION TABLE
TSX7 MASTER Type : LOCAL EXCHG TxTi, C = H'0737' TxTi, M = H'0069' E.g. station 5 XBT-A8 SERVER TxTi, L = 12 (bytes)	H'00'	H'01'	TxTi, R = H'FE' (TSX17) or TxTi, V = H'00FE' The XBT-A8 displays <div style="border: 1px solid black; padding: 5px; width: fit-content; margin: 0 auto;">ADJUST</div>
	H'07	H'D1'	
	H'00	H'03'	
	H'44'(D)	H'41'(A)	
	H'55'(U)	H'4A'(J)	
	H'54'(T)	H'53'(S)	

Requests to access XBT-A8 resources

• **Use of the NUL control character H'00' (continued)**

At the start of the cycle, the control system sends a new "Write object" request allowing the preceding display to be augmented (without erasing it). The message should be preceded by 6 NULs (H'00') so that the beginning of the message is in the 7th position.

CLIENT TEXT BLOCK			
CONFIGURATION	TRANSMISSION TABLE		RECEPTION TABLE
TSX7 MASTER Type : LOCAL EXCHG TxTi, C = H'0737' TxTi, M = H'0069' E.G. station 5 XBT-A8 SERVER TxTi, L = 22 (bytes)	H'00'	H'01'	Segment (word space) Display buffer address Number of objects (8 words) to write TxTi, R = H'FE' (TSX17) or TxTi, V = H'00FE' The XBT-A8 displays ADJUST COMPLETE
	H'07	H'D1'	
	H'00	H'08'	
	H'00'NUL	H'00'NUL	
	H'00'NUL	H'00'NUL	
	H'00'NUL	H'00'NUL	
	H'43'(C)	H'20'(SP)	
	H'4D'(M)	H'4F'(O)	
	H'4C'(L)	H'50'(P)	
	H'54'(T)	H'45'(E)	
	H'00'NUL	H'45'(E)	

The last NUL (H'00') in the most significant byte simply completes the transmission table (there must always be an even number of bytes in the data field). At the end of the cycle, the control system sends a new "Write object" request which allows the display to be altered. The message should be preceded by 6 NULs (H'00') to preserve the starting position for display.

CLIENT TEXT BLOCK			
CONFIGURATION	TRANSMISSION TABLE		RECEPTION TABLE
TSX7 MASTER Type : LOCAL EXCHG TxTi, C = H'0737' TxTi, M = H'0069' E.G. station 5 XBT-A8 SERVER TxTi, L = 22 (bytes)	H'00'	H'01'	Segment (word space) Display buffer address Number of objects (8 words) to write TxTi, R = H'FE' (TSX17) or TxTi, V = H'00FE' The XBT-A8 displays ADJUST COMPLETE
	H'07	H'D1'	
	H'00	H'08'	
	H'00'NUL	H'00'NUL	
	H'00'NUL	H'00'NUL	
	H'00'NUL	H'00'NUL	
	H'43'(C)	H'20'(SP)	
	H'4D'(M)	H'4F'(O)	
	H'4C'(L)	H'50'(P)	
	H'54'(T)	H'45'(E)	
	H'00'NUL	H'45'(E)	

5 Communication

Requests to access XBT-A8 resources

• Reading the message displayed on the XBT-A8

The message is read from the XBT-A8 display by reading the contents of the display buffer (address H'07D1' or 2001 in decimal). The request used by UNI-TE is "Read object".

Reading is always carried out by starting at the first position on the unit, however many characters are displayed.

Comment : The decimal points, displayed in the same position as a digit, are sent separately. This has to be taken into account when composing the request (reception table length).

Request format :

Designation	Request code	Sender category	Segment	Reserved	Object address	Number of objects to read
Format	1 byte	1 byte	1 byte	1 byte	1 word	1 word
Code	H'36'	H'07'	H'01'	H'00'	H'07D1'	H'01 à H'20'
Comments	Read objects	-	Access word space (physical address of words)	-	XBT-A8 display buffer address (in word space) : 2001 in decimal	Number of words to read : 32 words max => 64 characters max

Confirmation report format : Positive response

Designation	Response code	Reserved	Data
Format	1 byte	1 byte	64 bytes max
Code	H'66'	H'00'	H'..'H..'
Comments	-	-	Message shown on display

Requests to access XBT-A8 resources

Example : XBT-A8 response following the request to "read the message currently displayed".

CLIENT TEXT BLOCK																								
CONFIGURATION	TABLE EMISSION	TABLE RECEPTION																						
TSX7 MASTER Type : LOCAL EXCHG TxTi, C = H'0736' TxTi, M = H'0069' (E.g. station 5) XBT-A8 SERVER TxTi, L = 6 (bytes)	<table border="1"> <tr> <td>H'00'</td> <td>H'01'</td> </tr> <tr> <td>H'07'</td> <td>H'D1'</td> </tr> <tr> <td>H'00'</td> <td>H'08'</td> </tr> </table> Disp. buff. add. 7 words to read	H'00'	H'01'	H'07'	H'D1'	H'00'	H'08'	TxTi, V = H'0066' or TxTi, R = H'66' (TSX17) <table border="1"> <tr> <td>H'53'</td> <td>H'00'</td> </tr> <tr> <td>H'45'</td> <td>H'50'</td> </tr> <tr> <td>H'44'</td> <td>H'45'</td> </tr> <tr> <td>H'32'</td> <td>H'3D'</td> </tr> <tr> <td>H'32'</td> <td>H'3D'</td> </tr> <tr> <td>H'35'</td> <td>H'34'</td> </tr> <tr> <td>H'54'</td> <td>H'30'</td> </tr> <tr> <td>H'2E'</td> <td>H'4D'</td> </tr> </table> Message displayed SPEED = 2450TM.	H'53'	H'00'	H'45'	H'50'	H'44'	H'45'	H'32'	H'3D'	H'32'	H'3D'	H'35'	H'34'	H'54'	H'30'	H'2E'	H'4D'
H'00'	H'01'																							
H'07'	H'D1'																							
H'00'	H'08'																							
H'53'	H'00'																							
H'45'	H'50'																							
H'44'	H'45'																							
H'32'	H'3D'																							
H'32'	H'3D'																							
H'35'	H'34'																							
H'54'	H'30'																							
H'2E'	H'4D'																							

5 Communication

Requests to access XBT-A8 resources

• Cancelling a current operation

- INIT request

This request initializes the XBT-A8. The periodic updating of the variable associated with any message being displayed is interrupted and the XBT-A8 displays

*	RUNNING	*
---	---------	---

.

Request :

Designation	Request code	Sender category
Format	1 byte	1 byte
Code	H'33'	H'07'
Comments	Terminal initialization	-

Confirmation report format : Positive response

Designation	Response code	Confirm. report
Format	H'63'	1 byte
Code	H'63'	H'00'
Comments	-	INIT OK

Format for a negative response :

Response code	H'FD'
---------------	-------

Reasons for a negative response :

- request syntax incorrect,
- terminal reserved by another caller (see "Reservation" request),
- terminal message zone undergoing uploading or downloading sequence (see section 5.8 "Remote uploading and downloading of the memory area").

Example :

CLIENT TEXT BLOCK				
CONFIGURATION	TRANSMISSION TABLE	RECEPTION TABLE		
TSX7 MASTER Type : LOCAL EXCHG TxTi, C = H'0733' TxTi, M = H'0069' (E.g. station 5) XBT-A8 SERVER TxTi, L = 0 (bytes)	/	TxTi, V = H'0063' or TxTi, R = H'63' (TSX17) <table border="1" style="display: inline-table; vertical-align: middle;"> <tr> <td style="text-align: center;">H'00'</td> <td style="text-align: center;">INIT. OK.</td> </tr> </table>	H'00'	INIT. OK.
H'00'	INIT. OK.			

INIT. OK. : The XBT-A8 displays :

*	RUNNING	*
---	---------	---

5.6 Requests to access the XBT-A8 message segment

THE XBT-A8 MESSAGE SEGMENT CAN ONLY
BE ACCESSED IN READ MODE

The XBT-A8 message zone is composed of structured objects. Each message is a structured object consisting of a list of words which can be accessed in read mode by the "Read structured objects" request. In UNI-TE protocol, the XBT-A8 message zone is treated like a segment.

- **Segmentation of the message resource**

TYPE OF SEGMENT	MESSAGES
SEGMENT NUMBER	H'83 131 (decimal)
TYPE OF OBJECT	STORED MESSAGE
NUMBER OF OBJECTS	101
STRUCTURE OF MESSAGE OBJECT	TEXT TYPE COLUMN CONVERSION COEFFICIENT ASSOCIATED TSX7 VARIABLE VARIABLE UPDATE NETWORK NUMBER STATION NUMBER GATE NUMBER MODULE NUMBER CHANNEL NUMBER

5 Communication

Requests to access the XBT-A8 message segment

• Message structure

A message consists of text and parameters.

Each message object consists of a fixed format table of 28 words :

DESIGNATION	WORDS	MOST SIGNIF. BYTES	LEAST SIGNIF. BYTES	COMMENTS
MESSAGE TEXT (stored in the XBT-A8 terminal)	0	H'45' (E)	H'54' (T)	TEMP. EVAC. = ---
	1	H'50' (P)	H'4D' (M)	
	2	H'20' (SP)	H'2E' (•)	
	3	H'56' (V)	H'45' (E)	
	4	H'43' (C)	H'41' (A)	
	5	H'3D' (=)	H'2E' (•)	
	6	H'5F' (-)	H'5F' (-)	
7	H'20' (SP)	H'5F' (-)		
TYPE	8	H'20'	H'56'	Display
COLUMN	9	H'20'	H'32'	X = 2
CONVERSION COEFFICIENT	10	H'20'	H'01'	C = 1
	11	H'20'	H'20'	
	12	H'20'	H'20'	
ASSOCIATED VARIABLE ADDRESS	13	H'31'	H'57'	Word variable : W 00182
	14	H'32'	H'38'	
	15	H'20'	H'20'	
	16	H'20'	H'20'	
UPDATE	17	H'20'	H'33'	A=3 (period = 1 second)
NETWORK NUMBER	18	H'30'	H'30'	Network 000
	19	H'20'	H'30'	
STATION NUMBER	20	H'35'	H'32'	Station 254
	21	H'20'	H'34'	
GATE NUMBER	22	H'30'	H'30'	Gate 005
	23	H'20'	H'35'	
MODULE NUMBER	24	H'30'	H'30'	Module 004
	25	H'20'	H'34'	
CHANNEL NUMBER	26	H'30'	H'30'	Channel 002
	27	H'20'	H'32'	

The data is coded, starting with the least significant byte. Unused most significant bytes are filled with "SPACE" characters (H'20').

5 Communication

Requests to access the XBT-A8 message segment

• Reading a stored message

The "Read structured objects" request is used to access the text and parameters of stored messages.

Request format :

Designation	Request code	Sender category	Segment	Object address	Address of first element	Number of words to read
Format	1 byte	1 byte	1 byte	1 word	1 word	1 word
Code	H'34'	H'07'	H'83'	H'0000' to H'0064'	H'001B'	H'001C'
Comments	Read structured objects	-	Message area	Message number	Number of first word to read in the designated message	Number of words to read in the designated message (starting with the address of the 1 st message)

Confirmation report format : Positive response

Designation	Response code	Reserved	Data
Format	1 byte	1 byte	56 bytes max
Code	H'64'	H'00'	H'..'H'..'
Comments	-	-	Message object table requested H'1C' = 28 words => 56 bytes

Format for negative response :

Response code	H'FD'
---------------	-------

Reasons for a negative response :

- incorrect question syntax ,
- no right of access,
- unknown segment or object,
- address out of limits.

5 Communication

Requests to access the XBT-A8 message segment

Example : Reading stored message N° 83 (H'56).

CLIENT TEXT BLOCK																										
CONFIGURATION	TRANSMISSION TABLE	RECEPTION TABLE																								
<p>TSX7 MASTER Type : LOCAL EXCHG TxTi, C = H'0734' TxTi, M = H'0069' (E.g. station 5) XBT-A8 SERVER TxTi, L = 6 (bytes)</p>	<table border="1"> <tr> <td>H'56'</td> <td>H'83'</td> </tr> <tr> <td>H'00'</td> <td>H'00'</td> </tr> <tr> <td>H'00'</td> <td>H'08'</td> </tr> </table> <p>Segment message n° n° of 1st word Number of words : 8</p>	H'56'	H'83'	H'00'	H'00'	H'00'	H'08'	<p>TxTi, V = H'0064' or TxTi, R = H'64' (TSX17)</p> <table border="1"> <tr> <td>H'54'</td> <td>H'00'</td> </tr> <tr> <td>H'4D'</td> <td>H'45'</td> </tr> <tr> <td>H'2E'</td> <td>H'50'</td> </tr> <tr> <td>H'45'</td> <td>H'20'</td> </tr> <tr> <td>H'41'</td> <td>H'56'</td> </tr> <tr> <td>H'2E'</td> <td>H'43'</td> </tr> <tr> <td>H'5F'</td> <td>H'3D'</td> </tr> <tr> <td>H'5F'</td> <td>H'5F'</td> </tr> <tr> <td>H'00'</td> <td>H'20'</td> </tr> </table> <p>First 8 words in message table n° 83</p>	H'54'	H'00'	H'4D'	H'45'	H'2E'	H'50'	H'45'	H'20'	H'41'	H'56'	H'2E'	H'43'	H'5F'	H'3D'	H'5F'	H'5F'	H'00'	H'20'
H'56'	H'83'																									
H'00'	H'00'																									
H'00'	H'08'																									
H'54'	H'00'																									
H'4D'	H'45'																									
H'2E'	H'50'																									
H'45'	H'20'																									
H'41'	H'56'																									
H'2E'	H'43'																									
H'5F'	H'3D'																									
H'5F'	H'5F'																									
H'00'	H'20'																									

5.7 Handling operator acknowledgments

Operator acknowledgments (e.g. pressing a function key) are handled by the **master device** (e.g. TSX) on the UNI-TELWAY bus provided that the XBT-A8 operation serial line is configured WITH STATUS BLOCK (see section 4.3 Configuring the operation line).

Note : Reserve a **"status block"** in the master device using an **XBT-A8 terminal** connected to the UNI-TELWAY bus

- **Structure**

A "status block" consists of a table of 4 consecutive 16-bit words (W_{xxxx}) in the master device.

Address of 1st word in status block W_n
<p>Contains the number of the function key pressed by operator (direct or indirect access), associated with a message without a variable.</p> <p>Direct access : The number of the function key is loaded into W_n when the operator presses the key. $H'0001' \leq W_n \leq H'000C'$ ($1 \leq W_n \leq 12$)</p> <p>Indirect access : The function number is loaded when (ENTER) is pressed $H'000D' \leq W_n \leq H'0063'$ ($13 \leq W_n \leq 99$)</p>
Address of 2nd word in status block $W_n + 1$
<p>Use of function key :</p> <p>Press : $W_n + 1 = H'FFFF'$ ($W_n + 1 = - 1$)</p> <p>Release : $W_n + 1 = H'0000'$ ($W_n + 1 = 0$)</p> <p>(indirect access, action on (ENTER) key taken into account).</p>
Address of 3rd word in status block $W_n + 2$
<p>Contains the number of the type D message (blinking) present on the display acknowledged by the operator (by pressing (ENTER)).</p> <p>$H'0000' \leq W_n + 2 \leq H'0064'$ ($0 \leq W_n + 2 \leq 100$)</p>
Address of 4th word in status block $W_n + 3$
<p>Use (ENTER) to confirm end of numeric value displayed</p> <p>$W_n + 3 = H'00xx'$ xx = number of message associated with the numeric value ($H'00 \leq xx \leq H'64'$) or $xx = H'FF'$ if error</p>

**THE STATUS BLOCK IS INITIALIZED BY THE PROGRAM
IN THE PLC CONTAINING THE TABLE**

5.8 Remote uploading and downloading of XBT-A8 memory area

- **Principle**

The uploading sequence allows a CLIENT to load all or part of the message zone in an XBT-A8 SERVER and conversely. The downloading sequence allows an XBT-A8 SERVER to download all or part of its message zone to a CLIENT device.

The transfer is carried out using a complete message (text + attributes), representing 32 bytes per transmission.

THE CLIENT MUST BE ABLE TO HANDLE
TABLES OF AT LEAST 32 BYTES

Remote uploading

IT IS IMPORTANT THAT THE MESSAGE FILES INTENDED FOR
UPLOADING TO AN XBT-A8 SERVER BE IN
THE FORMAT OF THE XBT-A8 MESSAGE MEMORY

In order to obtain a message file in XBT-A8 format, first of all perform a remote downloading of the application file contained in the XBT-A8.

WARNING : REMOTE DOWNLOADING MAY ONLY BE CARRIED
OUT IF THE XBT-A8 TERMINAL IS FREE :
NO OPERATOR RESPONSE EXPECTED
(CONFIRMATION OF THE NUMERIC COMPOSITION OF A TYPE N
MESSAGE OR OF AN INDIRECT ACCESS FUNCTION NUMBER,
ACKNOWLEDGMENT OF A TYPE D BLINKING MESSAGE)
TO CANCEL ALL CURRENT OPERATIONS :
SEND THE INIT REQUEST (H'33) TO THE XBT-A8.

Remote downloading

A message file in an XBT-A8 may be downloaded from a client UNI-TELWAY station.

BEFORE REMOTE UPLOADING OR DOWNLOADING,
IT IS RECOMMENDED THAT THE XBT-A8 IS FIRST IDENTIFIED
BY SENDING THE " DEVICE IDENTIFICATION " REQUEST

5 Communication

Remote uploading and downloading of XBT-A8 memory area

• Procedure for REMOTE UPLOADING

The dialogue between the XBT-A8 SERVER and the CLIENT device during remote uploading is broken down into the following sequences :

	XBT-A8 ... SERVER	EXCHANGES (REQUESTS)	CLIENT DEVICE	COMMENTS
RESERVATION		← RESERVATION (H'1D')		Terminal reserved and 60 second "time envelope" starts
			→ CONFIRMATION REPORT (H'FE')	Confirmation report : terminal ready to serve requesting CLIENT
INITIALIZATION		← INITIALIZE UPLOADING (H'3A')		Open uploading sequence
			→ CONFIRMATION REPORT (H'6A')	Terminal ready to accept upload
UPLOAD		← UPLOAD A SEGMENT (H'3B' + segment N° + length + message text + attributes)		Write a message in the XBT-A8 server (32 bytes in XBT memory format)
			→ CONFIRMATION REPORT (H'6B' + Segment N° received)	The XBT-A8 sends the number of the message received
RENEW RESERVATION (IF NECESSARY)		← RENEW RESERVATION (H'2D')		Reset "time envelope" to 60 seconds if necessary (automatically frees the SERVER at the end of the time envelope if no request received)
			→ CONFIRMATION REPORT (H'FE')	Restart 60 second "time envelope"
CONTINUE UPLOADING (IF NECESSARY)		← UPLOADING A SEGMENT (H'3B' + Segment N° + length + message text + attributes)		Write another message to the XBT-A8 server if necessary (32 bytes in XBT memory format)
			→ CONFIRMATION REPORT (H'6B' + Segment N° received)	The XBT-A8 sends the number of the message received
END OF UPLOADING		← END OF UPLOADING (H'3C')		Close of uploading sequence
			→ CONFIRMATION REPORT (H'FE')	Terminal responds with OK after calculating and saving checksum to terminal message memory
FREE TERMINAL		← DERESERVATION (H'1E')		XBT-A8 terminal is freed
			→ CONFIRMATION REPORT (H'FE')	Once freed, the terminal goes to RUNNING MODE ready to receive new requests

Remote uploading and downloading of XBT-A8 memory area

• Procedure for REMOTE DOWNLOADING

The dialogue between the XBT-A8 SERVER and the CLIENT device during remote downloading is broken down into the following sequences :

	XBT-A8 ... SERVER	EXCHANGES (REQUESTS)	CLIENT DEVICE	COMMENTS
RESERVATION		RESERVATION (H'1D')		Terminal reserved and 60 second "time envelope" starts
		CONFIRMATION REPORT (H'FE')		Confirmation report : terminal ready to serve requesting CLIENT
INITIALIZATION		INITIALIZE DOWNLOADING (H'3D')		Open downloading sequence
		CONFIRMATION REPORT (H'6D')		Terminal ready to accept download
DOWNLOAD		DOWNLOAD A SEGMENT (H'3E' + segment N°)		CLIENT request to read a message from the XBT-A8 server
		CONFIRMATION REPORT (H'6E' + Segment N° + length + message text + attributes)		The XBT-A8 sends the message requested (32 bytes in XBT memory format)
RENEW RESERVATION (IF NECESSARY)		RENEW RESERVATION (H'2D')		Reset "time envelope" to 60 seconds if necessary (automatically frees the SERVER at the end of the time envelope if no request received)
		CONFIRMATION REPORT (H'FE')		Restart 60 second "time envelope"
CONTINUE DOWNLOADING (IF NECESSARY)		DOWNLOAD A SEGMENT (H'3E' + Segment N°)		CLIENT request to read a new message from the XBT-A8 server
		CONFIRMATION REPORT (H'6E' + Segment N° + length + message text + attributes)		The XBT-A8 sends the message requested (32 bytes in XBT memory format)
END OF DOWNLOADING		END OF DOWNLOADING (H'3F')		Close of downloading sequence
		CONFIRMATION REPORT (H'6F')		Terminal responds with OK
FREE TERMINAL		DERESERVATION (H'1E')		XBT-A8 terminal server is freed
		CONFIRMATION REPORT (H'FE')		Once freed, the terminal goes to RUNNING MODE ready to receive new requests

5 Communication

Remote uploading and downloading of XBT-A8 memory area

- **Specific requests**

- **Reservation :**

This service allows a CLIENT device to reserve an XBT-A8 SERVER with which it wants to dialogue when making use of critical requests (uploading, downloading, displaying a message, displaying a text, etc.). It simultaneously starts a 60 second "time envelope". If there are no requests from the reserver to the server within this period of time, the server is automatically freed and displays

* RUNNING *

 while waiting for a request.

Request format :

Designation	Request code	Sender category
Format	1 byte	1 byte
Code	H'1D'	H'07'
Comments	Reservation	-

Confirmation report format : Positive response

Response code	H'FE'
----------------------	-------

Example :

CLIENT TEXT BLOCK		
CONFIGURATION	TRANSMISSION TABLE	RECEPTION TABLE
Type : LOCAL EXCHG TxTi, C = H'071D' TxTi, M = H'0069' (E.g. station 5) XBT-A8 SERVER TxTi, L = 0 (bytes)	/	TxTi, V = H'00FE' or TxTi, R = H'FE' (TSX17) Positive response: terminal is reserved. If TxTi, R = H'FD' Negative response : - incorrect question syntax, - terminal already reserved by another CLIENT

**WARNING : WHEN THE XBT-A8 IS RESERVED,
ONLY THE RESERVER MAY CARRY OUT CRITICAL ACTIONS
(UPLOADING, DOWNLOADING, DISPLAYING, ETC.),
OTHER DEVICES MAY ONLY CARRY OUT NON-CRITICAL
REQUESTS (IDENTIFICATION, READING
THE COUNTERS, STATE OF THE TERMINAL, ETC.)**

5 Communication

Remote uploading and downloading of XBT-A8 memory area

• De-reservation :

On receipt of this request, the XBT-A8 server is freed and passes into

* RUNNING * ready to receive new requests.

Request format :

Designation	Request code	Sender category
Format	1 bytes	1 bytes
Code	H'1E'	H'07'
Comments	De-reservation	-

Confirmation report format : Positive response

Response code
H'FE'

Example :

CLIENT TEXT BLOCK		
CONFIGURATION	TRANSMISSION TABLE	RECEPTION TABLE
TSX7 MASTER Type : LOCAL EXCHG TxTi, C = H'071E' TxTi, M = H'0069' (E.g. station 5) XBT-A8 SERVER TxTi, L = 0 (bytes)	/	TxTi, V = H'00FE' TxTi, R = H'FE' (TSX17) Positive response : the terminal is freed. If TxTi, R = H'FD' Negative response : - terminal not reserved - terminal already reserved by another CLIENT.

5 Communication

Remote uploading and downloading of XBT-A8 memory area

• Renewing the reservation :

This request allows a CLIENT device which has reserved the server to retain and restart the 60 second "time envelope".

Request format :

Designation	Request code	Sender category code	Reserved word
Format	1 byte	1 byte	1 word
Code	H'2D'	H'07'	H'FFFF'
Comments	Renew the reservation	-	The contents of this word are not used by the XBT

Confirmation report format : Positive response

Response code
H'FE'

Example :

CLIENT TEXT BLOCK				
CONFIGURATION	TRANSMISSION TABLE	RECEPTION TABLE		
TSX7 MASTER Type : LOCAL EXCHG TxTi, C = H'072D' TxTi, M = H'0069' (E.g. station 5) TxTi, L = 2 (bytes)	<table border="1"> <tr> <td>H'FF</td> <td>H'FF'</td> </tr> </table>	H'FF	H'FF'	TxTi, V = H'00FE' or TxTi, R = H'FE' (TSX17) Positive response : 60 second time envelope is restarted. If TxTi, R = H'FD' Negative response : - terminal not reserved - terminal already reserved by another CLIENT
H'FF	H'FF'			

5 Communication

Remote uploading and downloading of XBT-A8 memory area

• Initialize loading

This request opens the loading sequence. It identifies the data which is going to be transmitted to the SERVER (determination of area, location, format, etc.).

Note : For this to take place, the SERVER must first of all be reserved.

Request format :

Designation	Request code	Sender category code	File name
Format	1 byte	1 byte	8 bytes
Code	H'3A'	H'07'	E _ M S A _ _ _
Comments	Open uploading sequence	-	File : EEPROM message memory (8 bytes coded in ASCII) Used to select the area for storing the messages

Confirmation report format : Positive response

Designation	Response code	Status
Format	1 byte	1 byte
Code	H'6A'	H'00'
Comments	Uploading sequence open	

Negative response :

Response code
H'FD'

- incorrect question syntax,
- terminal is not reserved by the requesting CLIENT,
- File Name Field bytes syntax not in the XBT-A8 memory format,
- uploading or downloading sequence is already open,
- segment number is not supported by the XBT-A8,
- terminal waiting for an operator response.

Remote uploading and downloading of XBT-A8 memory area

Example : Opening loading into the EEPROM message memory.

CLIENT TEXT BLOCK												
CONFIGURATION	TRANSMISSION TABLE	RECEPTION TABLE										
<p>TSX7 MASTER</p> <p>Type : LOCAL EXCHG</p> <p>TxTi, C = H'073A'</p> <p>TxTi, M = H'0069'</p> <p>(E.g. station 5)</p> <p>XBT-A8 SERVER</p> <p>TxTi, L = 8 (bytes)</p>	<table border="1"> <tr> <td>H'5F'</td> <td>H'45'</td> </tr> <tr> <td>H'53'</td> <td>H'4D'</td> </tr> <tr> <td>H'20'</td> <td>H'41'</td> </tr> <tr> <td>H'20'</td> <td>H'20'</td> </tr> </table> <p>File name (8 bytes)</p> <p>E _ M S A _ _ _</p> <p>Uploading area : message EEPROM</p>	H'5F'	H'45'	H'53'	H'4D'	H'20'	H'41'	H'20'	H'20'	<p>TxTi, V = H'006A' or</p> <p>TxTi, R = H'6A' (TSX17)</p> <table border="1"> <tr> <td></td> <td>H'00'</td> </tr> </table> <p>Positive response (uploading sequence open)</p>		H'00'
H'5F'	H'45'											
H'53'	H'4D'											
H'20'	H'41'											
H'20'	H'20'											
	H'00'											

5 Communication

Remote uploading and downloading of XBT-A8 memory area

• Loading a segment

This request allows the CLIENT to transfer a message (segment) into the SERVER terminal. Any number of segments can be transmitted in any order. This allows all or part of the XBT-A8 message memory zone to be uploaded.

Note : The terminal must be reserved and loading initialized, possibly followed by renewing the reservation, before transferring the first message.

Request format :

Designation	Response code	Sender category code	Segment number	Segment length	Data
Format	1 byte	1 byte	1 word	1 word	32 bytes
Code	H'3B'	H'07'	H'0000' à H'0064'	H'0020'	
Comments	Up-loading	-	Message number (000 to 100 decimal)	Segment message length 32 bytes	32 bytes XBT-A8 terminal memory format

Confirmation report format : Positive response

Designation	Response code	Status	Segment number
Format	1 byte	1 byte	1 word
Code	H'6B'	H'00'	H'0000' to H'0064'
Comments	-	Segment received	Number of segment received

5 Communication

Remote uploading and downloading of XBT-A8 memory area

Example : Uploading message number 083 (H'53') into the XBT-A8 memory.

CLIENT TEXT BLOCK																		
CONFIGURATION	TRANSMISSION TABLE	RECEPTION TABLE																
Type : LOCAL EXCHG TxTi, C = H'073B' TxTi, M = H'0069' (E.g. station 5) XBT-A8 SERVER TxTi, L = 36 (bytes)	<table border="1"> <tr> <td>H'00'</td> <td>53'</td> </tr> <tr> <td>H'00'</td> <td>20'</td> </tr> <tr> <td></td> <td></td> </tr> <tr> <td></td> <td></td> </tr> <tr> <td></td> <td></td> </tr> <tr> <td></td> <td></td> </tr> </table> Message N° 083 Segment length 32 bytes XBT-A8 memory format	H'00'	53'	H'00'	20'									TxTi, V = H'006B' or TxTi, R = H'6B' (TSX17) <table border="1"> <tr> <td>H'00'</td> <td>H'00'</td> </tr> <tr> <td>H'00'</td> <td>53'</td> </tr> </table> 1 status byte Number of seg. received (message N° 83) (H'53') TxTi, V = H'00FD' or TxTi, R = H'FD' negative response	H'00'	H'00'	H'00'	53'
H'00'	53'																	
H'00'	20'																	
H'00'	H'00'																	
H'00'	53'																	

Negative response :

Response code	H'FD'
----------------------	-------

- if the uploading sequence is not opened by the requester,
- if the syntax of the data is not in the XBT-A8 terminal memory format,
- if the number of the segment is not supported by the XBT-A8.

THE DATA TO BE LOADED INTO THE XBT-A8 MUST BE IN THE TERMINAL MEMORY FORMAT

5 Communication

Remote uploading and downloading of XBT-A8 memory area

• End of loading

This request closes the uploading sequence. After receipt of this request, the XBT-A8 SERVER calculates the checksum for the message memory and stores it.

Note : This request is only accepted if reservation and initialization of uploading has been previously carried out.

Request format :

Designation	Request code	Sender category
Format	1 byte	1 byte
Code	H'3C'	H'07'
Comments	End of uploading sequence	-

Confirmation report format : Positive response

Designation	Response code	Status
Format	1 byte	1 byte
Code	H'6C'	H'00'
Comments	-	Sequence close

Negative response :

Response code	H'FD'
---------------	-------

- if the request syntax is incorrect,
- if the uploading sequence was not opened by the requesting CLIENT.

Example :

CLIENT TEXT BLOCK		
CONFIGURATION	TRANSMISSION TABLE	RECEPTION TABLE
TSX7 MASTER Type : LOCAL EXCHG TxTi, C = H'073C' TxTi, M = H'0069' (E.g. station 5) XBT-A8 SERVER TxTi, L = 0 (bytes)	/	TxTi, V = H'006C' or TxTi, R = H'6C' (TSX17) <div style="border: 1px solid black; display: inline-block; padding: 2px;"> H'00' </div> 1 status byte (uploading sequence close)

5 Communication

Remote uploading and downloading of XBT-A8 memory area

• Initializing downloading

This request opens the downloading sequence and identifies the data which is to be downloaded to the requesting CLIENT (determination of location, format, etc.).

Note : For this to take place the XBT-A8 SERVER must be reserved.

Request format :

Designation	Request code	Sender category code	File name
Format	1 byte	1 byte	8 bytes
Code	H'3D'	H'07'	E _ M S A _ _ _
Comments	Open downloading sequence	-	File : EEPROM message memory (8 bytes coded in ASCII) Used to select the memory area for downloading the messages

Confirmation report format : Positive response

Designation	Response code	Status
Format	1 byte	1 byte
Code	H'6D'	H'00'
Comments	-	Sequence open

Negative response :

Response code
H'FD'

- if the terminal is not reserved by the requesting CLIENT,
- if the terminal is reserved by another requester,
- if an uploading or downloading sequence is already open.

5 Communication

Remote uploading and downloading of XBT-A8 memory area

Example : Opening the downloading sequence for the EEPROM message memory.

CLIENT TEXT BLOCK												
CONFIGURATION	TRANSMISSION TABLE	RECEPTION TABLE										
<p>TSX7 MASTER</p> <p>Type : LOCAL EXCHG</p> <p>TxTi, C = H'073D'</p> <p>TxTi, M = H'0069'</p> <p>(E.g. station 5)</p> <p>XBT-A8 SERVER</p> <p>TxTi, L = 8 bytes</p>	<table border="1"> <tr> <td>H'5F'</td> <td>H'45'</td> </tr> <tr> <td>H'53'</td> <td>H'4D'</td> </tr> <tr> <td>H'20'</td> <td>H'41'</td> </tr> <tr> <td>H'20'</td> <td>H'20'</td> </tr> </table> <p>File name (8 bytes)</p> <p>E _ M S A _ _ _ _</p>	H'5F'	H'45'	H'53'	H'4D'	H'20'	H'41'	H'20'	H'20'	<p>TxTi, V = H'006D' or TxTi, R = H'6D' (TSX17)</p> <table border="1"> <tr> <td></td> <td>H'00'</td> </tr> </table> <p>1 status byte</p> <p>(remote downloading open)</p>		H'00'
H'5F'	H'45'											
H'53'	H'4D'											
H'20'	H'41'											
H'20'	H'20'											
	H'00'											

5 Communication

Remote uploading and downloading of XBT-A8 memory area

• Downloading a segment

This request allows a CLIENT to read a message (segment) in the XBT-A8 SERVER format. Any number of segments can be read and transferred in any order. This allows all or part of the XBT-A8 message memory zone to be downloaded.

THE MESSAGES DOWNLOADED TO THE REQUESTING CLIENT
ARE IN THE FORMAT OF THE XBT-A8 SERVER MEMORY :
THIS MUST BE TAKEN INTO ACCOUNT
WHEN THE REQUESTING DEVICE PROCESSES THE DATA

Note : Reservation and initialization of downloading, followed by renewing the reservation if necessary, must be carried out before requesting that the first message be read.

Request format :

Designation	Request code	Sender category code	Segment number
Format	1 byte	1 byte	1 word
Code	H'3E'	H'07'	H'0000' to H'0064'
Comments	Downloading	-	Number of message requested

Confirmation report format : Positive response

Designation	Response code	Status	Segment number	Segment length	Data
Format	1 byte	1 byte	1 word	1 word	32 bytes
Code	H'6E'	H'00'	H'0000' to H'0064'	H'0020'	H'..' H'..'
Comments	-	-	Number of segment sent	Length 32 bytes	32 bytes in XBT RAM memory message format

Negative response :

Response code
H'FD'

- if the request syntax is incorrect,
- if the downloading sequence was not opened by the requester,
- if the address of the message segment number is non-existent or out of limits.

5 Communication

Remote uploading and downloading of XBT-A8 memory area

Example : Downloading message number 016 (H'10).

CLIENT TEXT BLOCK																
CONFIGURATION	TRANSMISSION TABLE	RECEPTION TABLE														
<p>TSX7 MASTER</p> <p>Type : LOCAL EXCHG</p> <p>TxTi, C = H'073E'</p> <p>TxTi, M = H'0069'</p> <p>(E.g. station 5)</p> <p>XBT-A8 SERVER</p> <p>TxTi, L = 2 (bytes)</p>	<table border="1"> <tr> <td>H'00</td> <td>H'10'</td> </tr> </table> <p>message N° 16 requested</p>	H'00	H'10'	<p>TxTi, V = H'006E' ou</p> <p>TxTi, R = H'6E' (TSX17)</p> <table border="1"> <tr> <td>H'10</td> <td>H'00'</td> </tr> <tr> <td>H'20</td> <td>H'00'</td> </tr> <tr> <td>H'00</td> <td>H'00'</td> </tr> <tr> <td></td> <td></td> </tr> <tr> <td></td> <td></td> </tr> <tr> <td></td> <td></td> </tr> </table> <p>1 status byte N° of segment received : 16 Segment length 32 bytes</p> <p>32 bytes XBT-A8 format</p>	H'10	H'00'	H'20	H'00'	H'00	H'00'						
H'00	H'10'															
H'10	H'00'															
H'20	H'00'															
H'00	H'00'															

5 Communication

Remote uploading and downloading of XBT-A8 memory area

• End of downloading

This request closes the downloading sequence.

Note : Only accepted if reservation is carried out.

Request format :

Designation	Request code	Sender category
Format	1 byte	1 byte
Code	H'3F'	H'07'
Comments	End of downloading sequence	-

Confirmation report format : Positive response

Designation	Response code	Status
Format	1 byte	1 byte
Code	H'6F'	H'00'
Comments	-	Sequence close

Example : Closing the downloading sequence.

CLIENT TEXT BLOCK			
CONFIGURATION	TRANSMISSION TABLE	RECEPTION TABLE	
TSX7 MASTER Type : LOCAL EXCHG TxTi, C = H'073F' TxTi, M = H'0069' (E.g. station 5) XBT-A8 SERVER TxTi, L = 0 bytes	/	If positive response : TxTi, V = H'006F' TxTi, R = H'6F' <table border="1" style="margin-left: auto; margin-right: auto;"> <tr> <td style="padding: 2px;">H'00'</td> </tr> </table> (downloading sequence close)	H'00'
H'00'			

Negative response TxTi, R = H'FD'
 TxTi, V = H'00FD' if :

- the request syntax is incorrect,
- the downloading sequence was not opened by the requester.

5.9 Requests used by CLIENT XBT-A8s

In this type of operation, the SERVER is a station which can be accessed via UNI-TELWAY and TELWAY7.

A station variable may be associated with each message in the XBT-A8. On pressing a "direct access" function key (messages 1 to 12) or using "indirect access" (messages 13 to 99), the numeric value of the associated variable is automatically read by the XBT-A8 from the associated TSX station. The value of this variable is displayed in the numeric field of the message and updated periodically (as a function of parameter A).

If the message is N type (numeric), the operator may alter the value using the XBT-A8 numeric keypad. When the value entered is confirmed by pressing **ENTER**, it is written by the terminal to the address of the associated variable indicated in the message (for example, see section 5.2 "XBT-A8 CLIENT").

While acting as a CLIENT, the XBT-A8 responds to UNI-TE standard requests (reading and writing bits and words), and to extended requests for TSX7 servers using ADJUST protocol.

REQUEST CODE	VARIABLE ADDRESSES	FUNCTION
H'00'	Bxxxx	Read internal bit
H'10'	Bxxxx	Write internal bit
H'04'	Wxxxxx	Read internal word
H'14'	Wxxxxx	Write internal word
H'02'	Ixxxx, xx	Read input bit image
	Oxxxx, xx	Read output bit image
H'05'	CWxxxxx	Read constant word
H'07'	COMxx, x	Read common word
H'09'	Txxx, V	Read current value of a timer
H'17'	Txxx, P	Write stored value of a timer
H'09'	Txxx, P	Read stored value of a timer
H'0B'	Cxxx, V	Read current value of a counter
H'19'	Cxxx, P	Write stored value of a counter
H'0B'	Cxxx, P	Read stored value of a counter
H'0A'	Mxxx, V	Read current value monostable
H'18'	Mxxx, P	Write stored value of a monostable
H'0A'	Mxxx, P	Read the stored value of a monostable
H'0C'	Dxxx, V	Read current step of a drum controller

- In order to determine the limits for addresses of accessible variables, the reader should refer to the user manuals for the TSX7 PLC being used.

- For additional information concerning the coding of requests and installing the UNI-TELWAY bus, please refer to the "UNI-TELWAY Bus Reference Manual" reference : TSX D24004E.

5.10 Summary of UNI-TE requests

XBT-A8 SERVER				
SERVICES	REQUESTS	QUESTIONS	POSITIVE RESPONSES	FUNCTIONS
GENERAL USE	Status	H'31'	H'61'	Detailed information about state of devices
	Identification	H'0F'	H'3F'	Provides the type, version and commercial reference of the product
	Protocol version	H'30'	H'60'	Communication protocol version and parameters
	Mirror	H'FA'	H'FB'	Tests the system and the communication route
	Read error counters	H'A2'	H'D2'	Handles logging of communication faults of a device
	Reset error counters to zero	H'A4'	H'FE'	Resets error counter to zero
DATA ACCESS	Write a bit	H'10'	H'FE'	- Controls keyboard LEDs - Locking/unlocking of keyboard keys - Buzzer control
	Write a word	H'14'	H'FE'	Global keyboard management Displays stored message
	Write objects	H'37'	H'FE'	- Controls keyboard LEDs - Locking/unlocking keyboard keys - Buzzer control - Displays messages (not stored)
	Read objects	H'36'	H'66'	Reads displayed message (display buffer)
	Read structured objects	H'34'	H'64'	Reads stored messages
MANAGEMENT OF SEMAPHORES	Reservation	H'1D'	H'FE'	Reserves a device and starts 60 second time envelope
	De-reservation	H'1E'	H'FE'	Authorizes dereservation of a reserved XBT-A8
	Renew the reservation.	H'2D'	H'FE'	Enables the XBT-A8 reservation to be renewed and restarts 60 second time envelope

Summary of UNI-TE requests

XBT-A8 SERVER				
SERVICES	REQUESTS	QUESTIONS	POSITIVE RESPONSES	FUNCTIONS
WORKING MODE	INIT	H'33'	H'63'	Initialize the XBT-A8 * RUNNING *
FILE TRANSFER	Initialize uploading	H'3A'	H'6A'	Establish sequence for remote uploading
	Upload a segment	H'3B'	H'6B'	Transfer a segment CLIENT -> SERVER
	End uploading	H'3C'	H'6C'	End of remote uploading sequence
	Initialize downloading	H'3D'	H'6D'	Establish sequence of remote downloading
	Download a segment	H'3E'	H'6E'	Transfer a segment SERVER -> CLIENT
	End downloading	H'3F'	H'6F'	End of remote downloading sequence

Summary of UNI-TE requests

XBT-A8 CLIENT				
SERVICES	REQUESTS	QUESTIONS	POSITIVE RESPONSES	FUNCTIONS
DATA ACCESS	Read an internal bit	H'00'	H'30'	Read bit Bxxxx TSX7
	Write an internal bit	H'10'	H'FE'	Write bit Bxxxx TSX7
	Read word	H'04'	H'34'	Read word Wxxxxx TSX7
	Write word	H'14'	H'FE'	Write word Wxxxxx TSX7
	Read I/O bit image	H'02'	H'32'	Input bit Ixxxx, xx Output bit Oxxxx, xx
	Read constant word	H'05'	H'35'	Word CWxxxxx
	Read common word	H'07'	H'37'	Word COMxx, x
	Read timer	H'09'	H'39'	Current value Txxx, V Stored value Txxx, P
	Write timer	H'17'	H'FE'	Preset value Txxx, P
	Read counter	H'0B'	H'3B'	Current value Cxxx, V Preset value Cxxx, P
	Write counter	H'19'	H'FE'	Preset value Cxxx, P
	Read monostable	H'0A'	H'3A'	Current value Mxxx, V + preset Mxxx, P
	Write monostable	H'18'	H'FE'	Preset value Mxxx, P
	Read drum controller	H'0C'	H'3C'	Step being executed Dxxx, V depends on TSX implement.

6 Application example

• Warning

The application example which follows is simplified, especially the internal initialization part which is needed for simulation. This is to make the explanations easier to understand. Only the program concerning the XBT-A8 exchanges is described.

Note : For a complete description of the TSX-SCG116 communication module and the use of text blocks, refer to the various manuals for the TSX7 range.

• Application

- Equipment layout

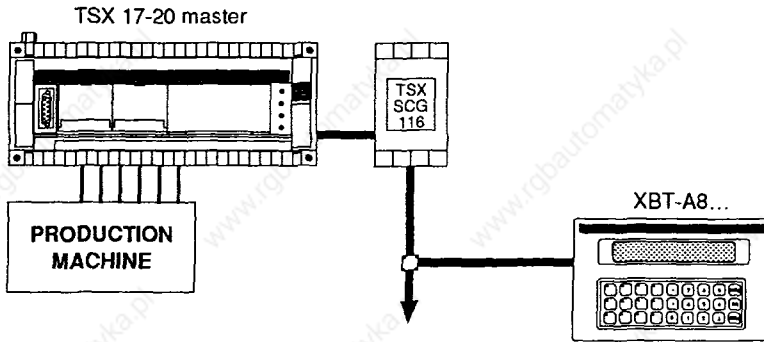

- A TSX 17 PLC controls a production machine. The TSX 17 is connected to the UNI-TELWAY bus by a TSX SCG116 master module.
- An XBT-A81010 display terminal connected to UNI-TELWAY informs the operator about the state of the machine and the number and type of items manufactured.

• Operating principle

- The production machine can manufacture two types of item (A and B), the choice of A or B being performed by a selector switch (while the machine is stopped).
- XBT-A8 displays :
 - in stop, the type of item selected (A or B)
 - in run, the number of items manufactured,
 - if the machine stops due to a fault, the FAULT message.

The occurrence of a fault stops the machine and re-starts the counters.

6 Application example

• Use of PLC objects

- Module configuration table

CONSTANT WORDS	HEX CODE
CW0	H'5002'
CW1	H'0000'
CW2	H'9600'
CW3	H'0010'
CW4	H'0000'
CW5	H'0000'
CW6	H'0000'
CW7	H'0000'
CW8	H'0000'
CW9	H'0000'

UNI-TELWAY master
2 connections scanned

Data rate 9600 bits/sec
Time-out

- Variable words

ADDRESS	FUNCTION
W98	Counter for items manufactured
W99	Reference item selected
W100	Maximum number of items (initialized at the start by a value)
W101	Number of A items manufactured
W102	Number of B items manufactured
W30	Start of communication text block (T1) : display unit address
W31	Communication text block table (T1) : number of XBT-A8 message to be displayed

- Assignment of inputs

BITS	FUNCTION
I0,0	Select on/off
I0,1	Select type of item A or B
I0,2	Machine fault

6 Application example

• Program

INITIALIZATION OF UNI-TE MODULE

LAB : 1



LAB : 3

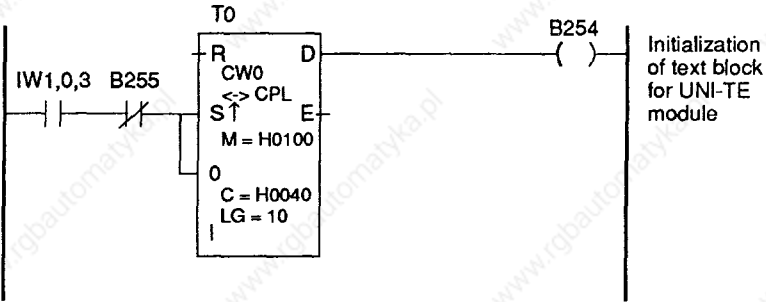

LAB : 5



POWER-UP - MACHINE IN STOP

LAB : 11



6 Application example

INITIALIZATION OF THE COMMUNICATION TABLE

LAB : 15

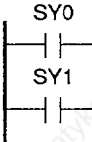

401 → W30

Transfer the "XBT-A8 display address" to W30 (start of communication text block table)

LAB : 50

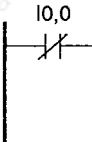

B20
(S)
B21
(R)

Machine stopped

LAB : 52

Machine in run and no faults



B20
(R)
B21
(S)

Machine running and no fault



B20
(S)
B21
(R)

Machine stopped due to fault

6 Application example

LAB : 102

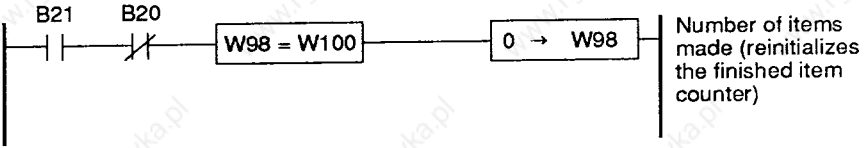

INITIALIZATION OF TRANSMISSION TABLE : SELECT THE NUMBER OF THE MESSAGE TO BE DISPLAYED ON THE XBT-A8

LAB : 116

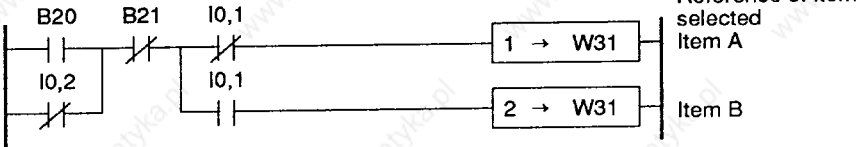

LAB : 118

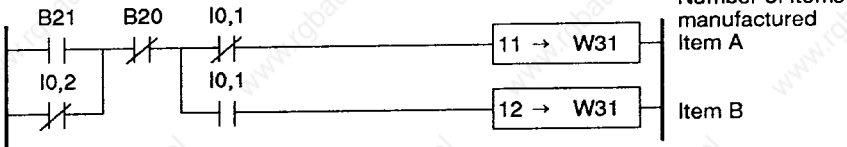

MACHINE FAULT

LAB : 120



LAB : 200

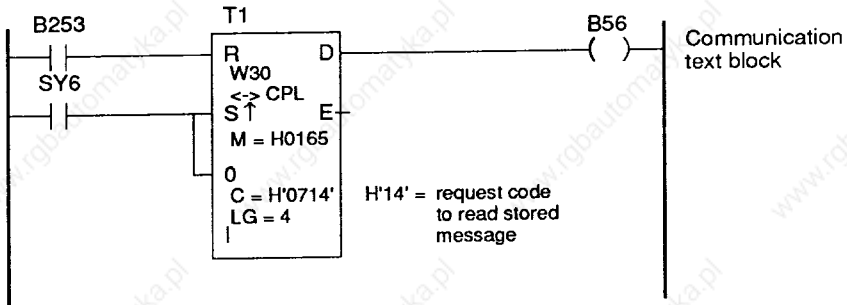

6 Application example

LAB : 56

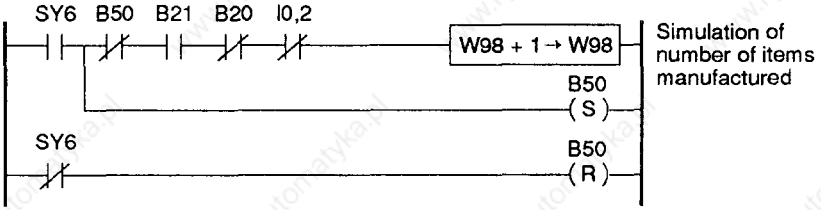

LAB : 58

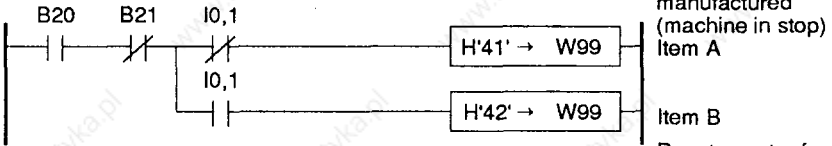

LAB : 60

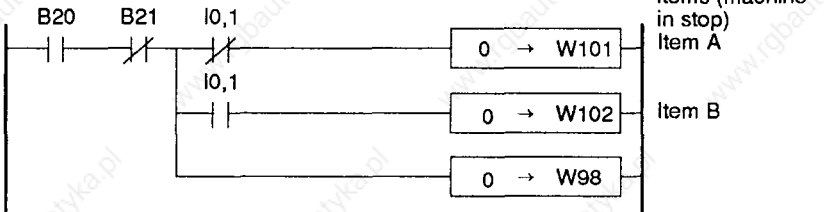

LAB : 100

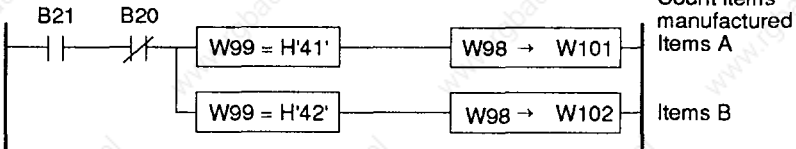

7.1 Pin connections

• Serial link connector pin connections

25 pin female
subminiature
HE50
connector

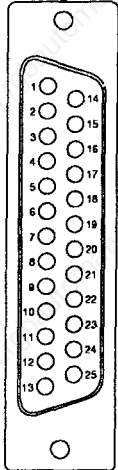

Pin number	DESIGN.	FUNCTION
1	PG	Physical ground \perp
2	TXD	Transmission RS 232C
3	RXD	Reception RS 232C
4	A	Transmission RS 422/485 (TXD+)
5	B	Transmission RS 422/485 (TXD-)
6	A'	Reception RS 422/485 (RXD+)
7	SG	COMMON RS 232C (0V)
8	COM	COMMON multidrop address and ADJUST (pins 12, 14 to 17, 19 and 24)
9	RXD+	Current loop reception, isolated
10	RXD-	Current loop reception, isolated
11		Reserved
12	REG	Select ADJUST MODE
13		Reserved
14	B0	Address of UNI-TELWAY multidrop terminal (binary 1)
15	B1	Address of UNI-TELWAY multidrop terminal (binary 2)
16	B2	Address of UNI-TELWAY multidrop terminal (binary 4)
17	B3	Address of UNI-TELWAY multidrop terminal (binary 8)
18	B'	Reception RS 422/485 (RXD-)
19	B4	Address of UNI-TELWAY multidrop terminal (binary 16)
20	TXD+	Current loop transmission, isolated
21	TXD-	Current loop transmission, isolated
22	SG	COMMON RS 422/485 (0V isolated)
23		Reserved
24	PAR	UNI-TELWAY multidrop address parity
25		Reserved

IN ORDER TO ENSURE GOOD ELECTRICAL CONNECTION, FIX THE SERIAL LINK CABLE CONNECTOR IN PLACE WITH THE TWO BOLTS

• Supply

+	-	\perp
POWER SUPPLY		PG (physical ground)
24 V ===	0 V ===	

WARNING :
BEFORE MAKING A CONNECTION, CHECK THE CORRESPONDENCE BETWEEN THE TERMINAL PINS AND THE ASSOCIATED CONTROL SYSTEM, OTHERWISE DAMAGE MAY BE CAUSED ON POWER-UP AND THE GUARANTEE RENDERED NULL AND VOID

7 Connections

7.2 Connections to PC-PS/2 computer

The XBT-A8 terminal is connected to a PC-PS/2 for operations on the XBT-A8 message memory (creating, storing, modifying or transferring) with XBTEL software.

**ONLY THE RS 232C STANDARD MAY BE USED.
ANY OTHER TYPE OF CONNECTION ABSOLVES TELEMECANIQUE
FROM THE TERMS OF THE GUARANTEE IN THE EVENT OF DAMAGE**

With XBTEL the communication parameters cannot be modified (RS 232C).
Connection is made at the PC serial port (COM 1).

Serial port connector PC-PS/2	Cables	
	Ref. number	Length
9-pin male	XBT-Z915	2.50 m
25-pin female	XBT-Z905	
25-pin male	XBT-Z9052	

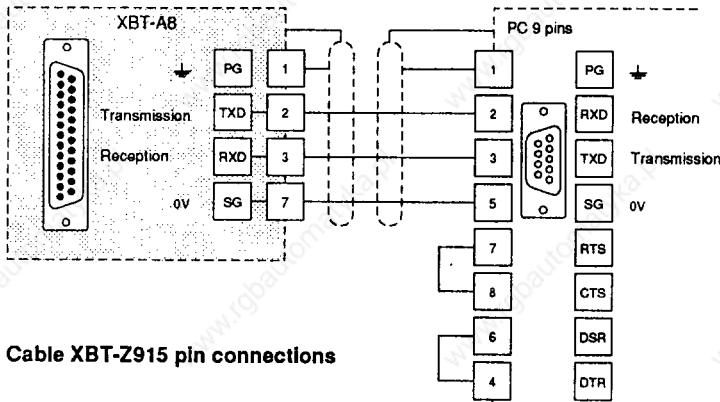

Cable XBT-Z915 pin connections

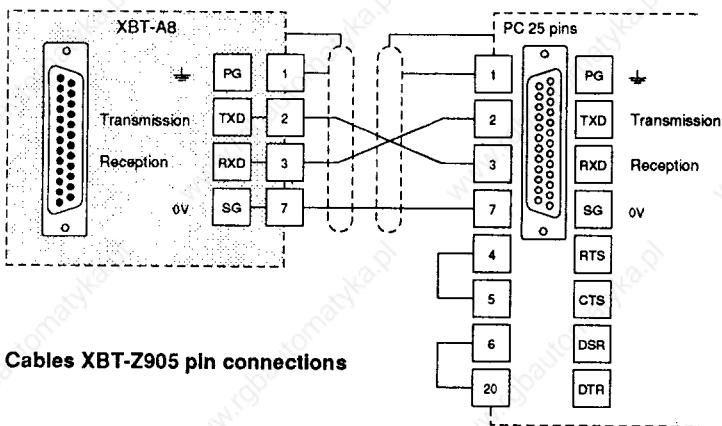

Cables XBT-Z905 pin connections

7.3 Connections to the UNI-TELWAY bus

• Connecting the XBT-A8 to the TSX-SCG116 module

In the case of a UNI-TELWAY point-to-point link with TSX 17-20 between a TSX-SCG116 master module and an XBT-A8, use a 5 m cable, type XBT-Z928.

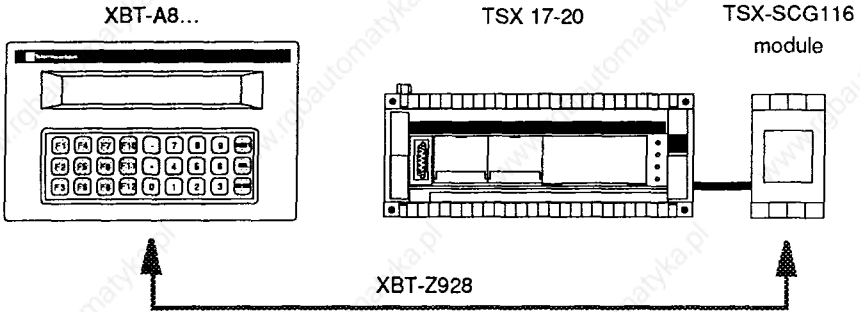

Cable XBT-Z928 pin connections

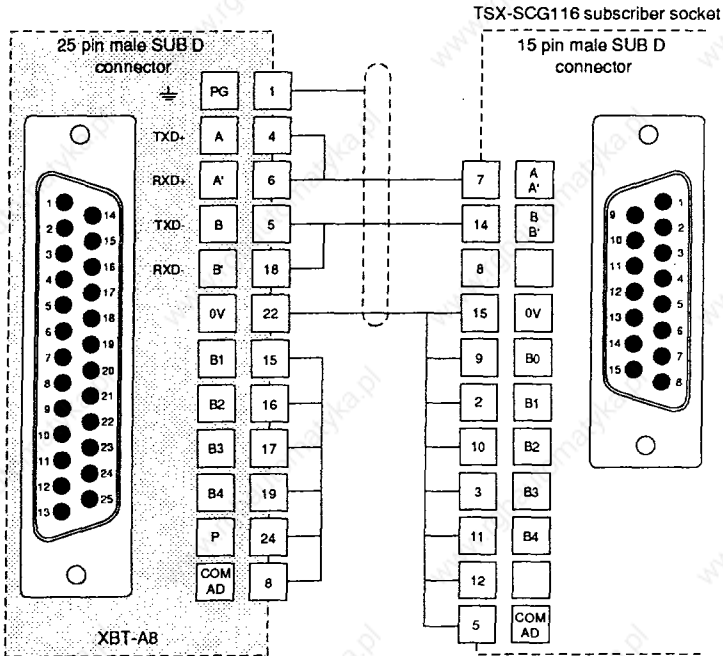

THE ADDRESSES FIXED BY THE XBT-Z928 CABLE ARE :
 0 FOR THE TSX-SCG116 MODULE
 1 FOR THE XBT-A8 TERMINAL

7 Connections

Connections to the UNI-TELWAY bus

• Connecting the XBT-A8 to the SCM 21.X6 module

In the case of a UNI-TELWAY point-to-point link with (TSX47/67/87) between an SCM 216 master module and an XBT-A8 slave, use a 5m XBT-Z918 cable.

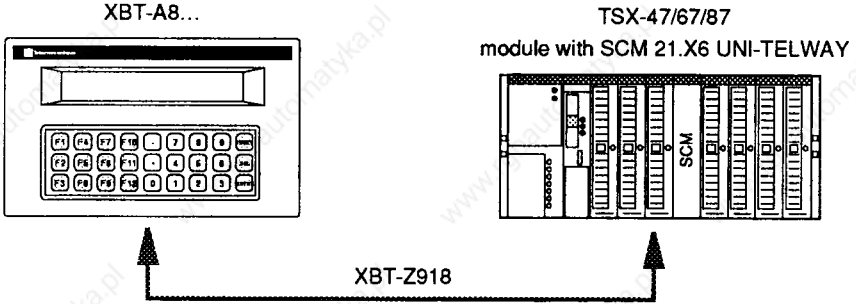

Connecting the XBT-Z918 cable : end of cable with XBT-Z918 reference to be connected to the XBT.

XBT-A8s have an RS 485 serial interface which conforms to the physical layer.

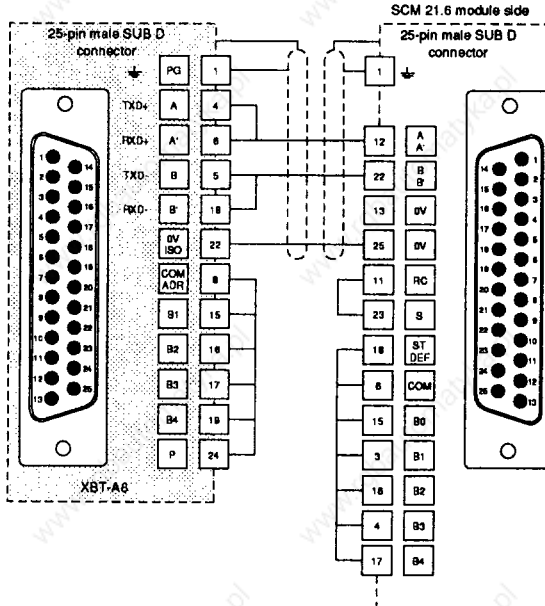

THE ADDRESSES ALREADY INCORPORATED
IN THE XBT-Z918 CABLE ARE :
0 FOR THE TSX SCM 21.6 MODULE
1 FOR THE XBT-A8 TERMINAL

Connections to the UNI-TELWAY bus

• Connecting the XBT-A8 to an SCA62 subscriber socket

In the case of a UNI-TELWAY multidrop link between the XBT-A8 and a TSX-SCA62 type subscriber socket, use a 1.8 m XBT-Z908 cable.

THE XBT-A8 ADDRESS BETWEEN 1 AND 31 IS CODED BY POSITIONING THE MICRO-SWITCH INSIDE THE TSX-SCA62 SUBSCRIBER SOCKET

THE XBT-A8 OCCUPIES 2 ADDRESSES ON THE BUS (THE CODED ADDRESS AND THE CODED ADDRESS +1)

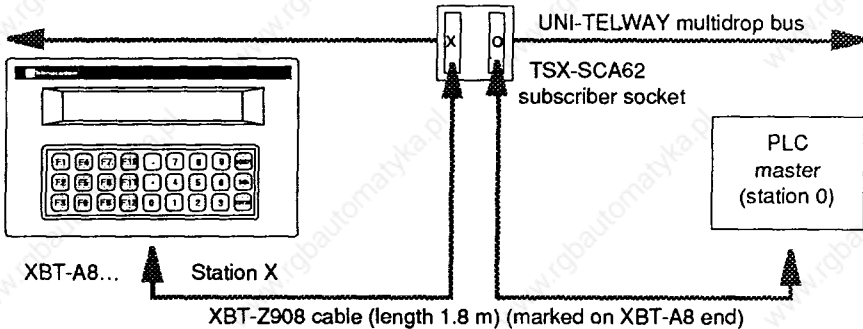

The TSX-SCA62 subscriber socket should be coded 0 for communication with the TSX7 PLC master.

Cable XBT-Z908 pin connections

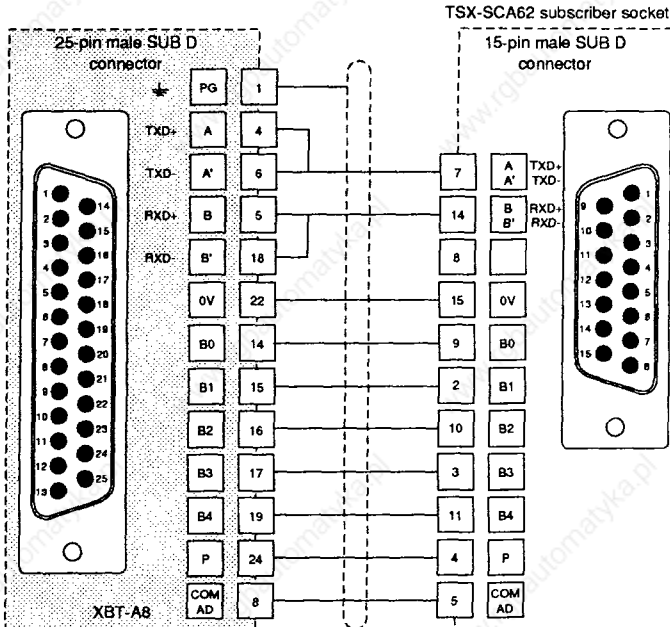

7.4 Test connectors

During CONFIGURATION, selection of the TEST procedure enables the user to check that the XBT-A8 terminal sub-assemblies are in good working order, in particular the physical links and the addresses.

Before starting to test a particular link (RS 232C, 20 mA current loop, RS 422), or the terminal addresses, place the relevant test connector on the serial port (to be wired as shown below). The test is then set in motion by pressing **DEL**.

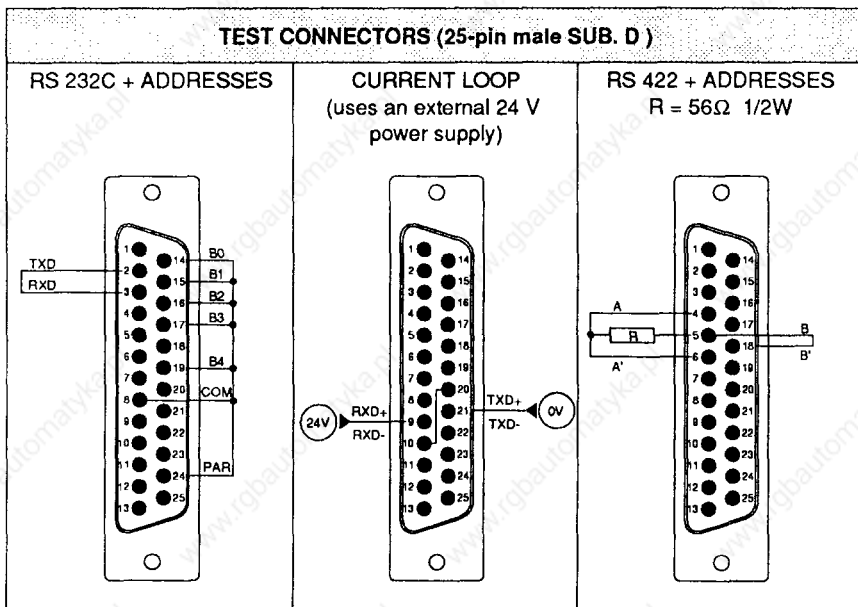

8.1 Automatic self-tests

When powering-up the XBT-A8 terminal, a series of tests is carried out automatically. These tests are also carried out during the test procedure of the CONFIGURATION mode. These checks are intended to reassure the user that the terminal is operating under the best conditions.

In order to quit a permanent fault, the supply voltage must be switched off.

TEST	DISPLAY	COMMENTS
PROM	*****	Internal FAULT if display permanent
	CHECK. PROG XXXX	Micro-program fault If display permanent => return the product
	XBT-A8 xxx VX.X	Brief display of the product reference and the software version
RAM	> RAM FAULT <	Memory FAULT If display permanent => return the product
REGISTER	> KEYBOARD FAULT <	FAULT with keyboard coding circuit If display permanent => return the product (check that no key is depressed)
	* RUNNING *	The XBT-A8 terminal is ready to use
EEPROM MESSAGE MEMORY	> EEPROM FAULT <	FAULT with EEPROM checksum. Press  to free the terminal. If fault persists => return the product.

8.2 Error messages

MESSAGE DISPLAYED	FUNCTION MODE	PROBABLE CAUSE	REMEDY
> LINE FAULT <	ADJUST MODE	Line fault XBT/TSX7	<ul style="list-style-type: none"> - Check the wiring - Test XBT-A8 serial port - Test the TSX terminal port - Check the position of TSX 7 memory cartridge lock
> TSX DATA FAULT <	ADJUST MODE	Non-existent TSX7 variable	<ul style="list-style-type: none"> - Check use of the variable in the TSX7
** --- ** (in the numeric field)	ADJUST MODE ASCII MODE	Value too large for numeric field	<ul style="list-style-type: none"> - Check the length of the numeric field - Check the conversion coefficient for the XBT-A8
>XXX = NO MESSAGE<	ADJUST MODE ASCII MODE	No message stored at address XXX	<ul style="list-style-type: none"> - Program the message - Change the address of the command
>AD PARITY FAULT<	ASCII MODE MULTIDROP	Addresses wired incorrectly	<ul style="list-style-type: none"> - Check the address wiring
>BAD RECORD<	STORING THE MESSAGES	Message incorrectly written in memory	<ul style="list-style-type: none"> - Check the message syntax
>EEPROM FAULT<	STORING THE MESSAGES	Power switched off during the storing procedure	<ul style="list-style-type: none"> - Press  to confirm

Summary of UNI-TE requests

• Messages specifically connected with UNI-TE protocol

MESSAGE DISPLAYED	FUNCTION MODE	PROBABLE CAUSE	REMEDY
> LINE FAULT <	UNI-TE PROTOCOL	<ul style="list-style-type: none"> - Address fault - Link between XBT-A8 and UNI-TELWAY module faulty - UNI-TELWAY station N° wired for XBT-A8 exceeds maximum configured for module - Module faulty 	<ul style="list-style-type: none"> The XBT-A8 occupies 2 addresses on the UNI-TELWAY bus (see section 5.4 UNI-TELWAY general). Check XBT-A8 addresses - Check the cable between the XBT-A8 and the module - Test the XBT-A8 serial port (see SELF-TESTS in section 4.1) - Check configuration of the module and the XBT-A8 station N° - Check the results of the module self-tests
>NO STATION<	UNI-TE PROTOCOL	<ul style="list-style-type: none"> No response to an XBT-A8 request UNI-TELWAY parameters incorrect, indicating a non-existing or faulty device 	<ul style="list-style-type: none"> Check parameters UNI-TELWAY NETWORK N° STATION N° GATE N° MODULE N° CHANNEL N° in the configuration of the serial line for operation (section 4.3)
>REFUSAL STATION<	UNI-TE PROTOCOL	<ul style="list-style-type: none"> Device refuses the action requested by the XBT-A8 because : - The variable does not exist for this station - The action requested is not allowed 	<ul style="list-style-type: none"> Check the address of the variable associated with the message Check the request code sent

Summary of UNI-TE requests

Messages specifically connected with UNI-TE protocol (continued)

MESSAGE DISPLAYED	FUNCTION MODE	PROBABLE CAUSE	REMEDY
>AD PARITY FAULT<	UNI-TE PROTOCOL	Addresses incorrectly wired	- Check the UNI-TELWAY address cabling - Check TSX SCA 62 subscriber socket coding
NETW ADDR ERROR	UNI-TE PROTOCOL	- Address fault	Same as for "Line fault"
DATA ADDRESS ERROR	UNI-TE PROTOCOL	- The variable does not exist in the TSX 7 station	Same as for "Refusal station"
>OVERFLOW<	UNI-TE PROTOCOL	- Value entered by the operator too large	- Re-enter the value
INEXECUTABLE	UNI-TE PROTOCOL	- If message is type F associated with word Confirmed without numeric value or with incorrect value	- Re-enter the numeric value

8.3 Table of ASCII codes

(Characters displayed by the Latin version of XBT-A8)

(ASCII : American Standard Code for Information Interchange).

BINARY				b6				b5				b4				b3				b2				b1				b0			
				0	0	0	0	1	1	1	1	0	0	1	1	0	0	1	1	0	0	1	1	0	0	1	1	0	0	1	1
				HEXADECIMAL				0	1	2	3	4	5	6	7	2	3	4	5												
b3	b2	b1	b0					0	1	2	3	4	5	6	7	0	1	2	3												
0	0	0	0	0				NUL	DLE	SP	0	@	P	'	p	0		N	O	P											
0	0	0	1	1				SOH	DC1	!	1	A	Q	a	q	1	V	I	R	Q											
0	0	1	0	2				STX	DC2	"	2	B	R	b	r	2	"	2	R	R											
0	0	1	1	3				ETX	DC3	#	3	C	S	c	s	3	#	3	O	S											
0	1	0	0	4				EOT	DC4	\$	4	D	T	d	t	4	\$	4	O	T											
0	1	0	1	5				ENQ	NAK	%	5	E	U	e	u	5	%	5	E	U											
0	1	1	0	6				ACK	SYN	&	6	F	V	f	v	6	&	6	F	V											
0	1	1	1	7				BEL	ETB	'	7	G	W	g	w	7	'	7	G	W											
1	0	0	0	8				BS	CAN	(8	H	X	h	x	8	(8	H	X											
1	0	0	1	9				HT	EM)	9	I	Y	i	y	9)	9	I	Y											
1	0	1	0	A				LF	SUB	*	:	J	Z	j	z	A	*	:	J	Z											
1	0	1	1	B				VT	ESC	+	;	K	[k	{	B	+	;	K	[
1	1	0	0	C				FF	FS	,	<	L	\	l		C	,	<	L	\											
1	1	0	1	D				CR	GS	-	=	M]	m	}	D	-	=	M]											
1	1	1	0	E				SO	RS	.	>	N	^	n	~	E	.	>	N	^											
1	1	1	1	F				SI	US	/	?	O	_	o	DEL	F	/	?	O	_											

control characters

displayable characters

characters displayed by the XBT

8 Appendices

Table of ASCII codes

(Characters displayed by the Cyrillic version of XBT-A8 and configured in Russian).

(ASCII : American Standard Code for Information Interchange).

BINARY				b ₆								b ₅		b ₄				
				0	0	0	0	1	1	1	1	1	1	0	0	1	1	
b ₃	b ₂	b ₁	b ₀	b ₄								0	1	0	1	0	1	
HEXADECIMAL				0	1	2	3	4	5	6	7	6	7	2	3	6	7	
0	0	0	0	0	NUL	DLE	SP	0	@	P	·	p	,	Ц				
0	0	0	1	1	SOH	DC ₁	!	1	A	Q	a	q	А	Я	✓	1	А	Я
0	0	1	0	2	STX	DC ₂	"	2	B	R	b	r	Б	Р	"	2	Б	Р
0	0	1	1	3	ETX	DC ₃	#	3	C	S	c	s	Ц	С	#	3	Ц	С
0	1	0	0	4	EOT	DC ₄	\$	4	D	T	d	t	Д	Г	\$	4	Д	Г
0	1	0	1	5	ENQ	NAK	%	5	E	U	e	u	Е	У	%	5	Е	У
0	1	1	0	6	ACK	SYN	&	6	F	V	f	v	Ф	Ж	&	6	Ф	Ж
0	1	1	1	7	BEL	ETB	'	7	G	W	g	w	Г	В	'	7	Г	В
1	0	0	0	8	BS	CAN	(8	H	X	h	x	Ж	Ь	(8	Ж	Ь
1	0	0	1	9	HT	EM)	9	I	Y	i	y	К	Ц)	9	К	Ц
1	0	1	0	A	LF	SUB	*	:	J	Z	j	z	Й	Э	*	:	Й	Э
1	0	1	1	B	VT	ESC	+	;	K	[k	{	К	Щ	+	;	К	Щ
1	1	0	0	C	FF	FS	,	<	L	\	l		Л	Э	,	<	Л	Э
1	1	0	1	D	CR	GS	-	=	M]	m	}	М	Щ	-	=	М	Щ
1	1	1	0	E	SO	RS	.	>	N	^	n	~	Н	Ч	.	>	Н	Ч
1	1	1	1	F	SI	US	/	?	O	_	o	DEL	О	DEL	/	?	О	DEL

control
characters

displayable
characters

characters displayed by the XBT

The products, hardware and services presented in this document are liable to be changed at any time with respect to the presentation of the characteristics, operation or utilisation. Their description cannot be used as a basis for contractual purposes .

© Copyright Telemecanique 1990. All reproduction of this document is forbidden. Copying or reproduction, even partial, by whatever means, photographic, magnetic, or other as well as any other partial or total transcription able to be read by an electronic device is strictly forbidden.